

AD-A049 434

NAVY PERSONNEL RESEARCH AND DEVELOPMENT CENTER SAN D--ETC F/6 5/9
MEASURING SUBMARINE APPROACH OFFICER PERFORMANCE ON THE 21A40 T--ETC(U)
JAN 78 J R CALLAN, R T KELLY, A NICOTRA

UNCLASSIFIED

NPRDC-TR-78-9

NL

| OF |

AD
A049434

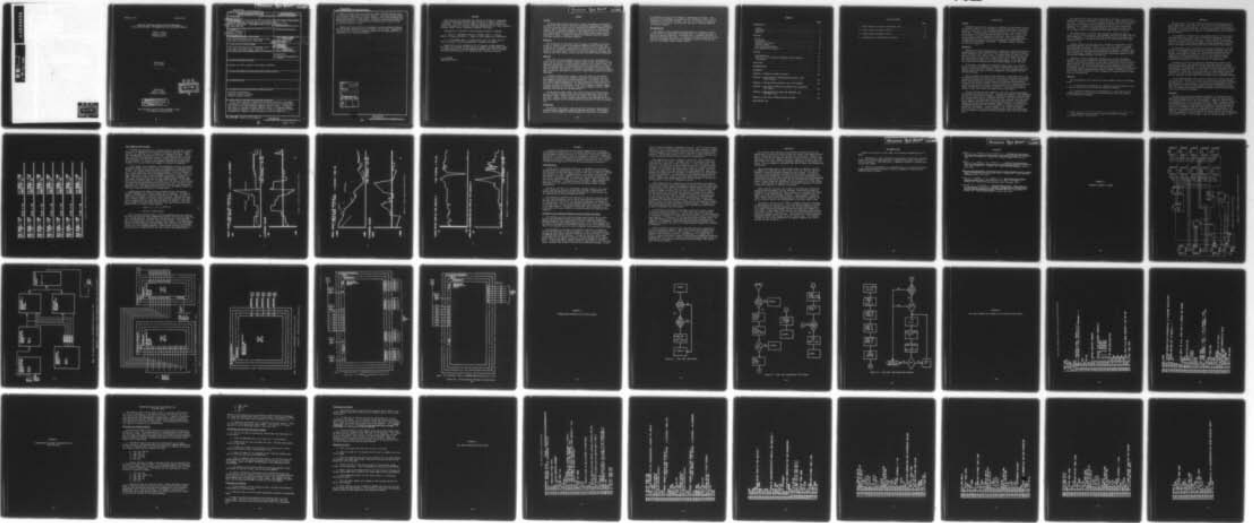

END
DATE
FILMED
3 - 78
DDC

AD A049434

AD No.  * DC, FILE COPY

DDC
RECEIVED
FEB 3 1978
B

MEASURING SUBMARINE APPROACH OFFICER PERFORMANCE
ON THE 21A40 TRAINER: INSTRUMENTATION AND PRELIMINARY RESULTS

James R. Callan
Richard T. Kelly
Anthony Nicotra

Reviewed by
M. W. O'Bar

BLANK PAGE

Approved by
James J. Regan
Technical Director

DDC
RECEIVED
FEB 3 1978
B

DISTRIBUTION STATEMENT A
Approved for public release;
Distribution Unlimited

Navy Personnel Research and Development Center
San Diego, California 92152

Preceding Page BLANK - FILMED

UNCLASSIFIED

SECURITY CLASSIFICATION OF THIS PAGE (When Data Entered)

REPORT DOCUMENTATION PAGE		READ INSTRUCTIONS BEFORE COMPLETING FORM
1. REPORT NUMBER 14 NPRDC-TR-78-9 ✓	2. GOVT ACCESSION NO.	3. RECIPIENT'S CATALOG NUMBER
4. TITLE (and Subtitle) 6 MEASURING SUBMARINE APPROACH OFFICER PERFORMANCE ON THE 21A40 TRAINER: INSTRUMENTATION AND PRELIMINARY RESULTS.		5. TYPE OF REPORT & PERIOD COVERED 9 Interim report.
7. AUTHOR(s) 10 James R. Callan, Richard T. Kelly Anthony Nicotra		6. PERFORMING ORG. REPORT NUMBER
9. PERFORMING ORGANIZATION NAME AND ADDRESS Navy Personnel Research and Development Center San Diego, California 92152 (Code 305) ✓		8. CONTRACT OR GRANT NUMBER(s)
11. CONTROLLING OFFICE NAME AND ADDRESS Navy Personnel Research and Development Center San Diego, California 92152 (Code 305)		10. PROGRAM ELEMENT, PROJECT, TASK AREA & WORK UNIT NUMBERS 62763N 16 F62522 47 ZF613512801 03.02 14/12/25
14. MONITORING AGENCY NAME & ADDRESS (if different from Controlling Office)		12. REPORT DATE 11 January 1978
		13. NUMBER OF PAGES 55 12 58 P.
		15. SECURITY CLASS. (of this report) UNCLASSIFIED
		15a. DECLASSIFICATION/DOWNGRADING SCHEDULE
16. DISTRIBUTION STATEMENT (of this Report) Approved for public release; distribution unlimited.		
17. DISTRIBUTION STATEMENT (of the abstract entered in Block 20, if different from Report)		
18. SUPPLEMENTARY NOTES		
19. KEY WORDS (Continue on reverse side if necessary and identify by block number) Performance measurement Submarine tactical training Computer graphics display		
20. ABSTRACT (Continue on reverse side if necessary and identify by block number) This report describes a method for providing unobtrusive performance measurement of submarine approach officers and fire control parties while they train on the 21A40 Advanced Submarine Attack Trainer. A system is described for coupling the 21A40 computer (UYK-7) to a desktop computer with graphics capability (Tektronix 4051) in order to sample fire control parameters for display in post-training critique and evaluation. → over		

16/12/25
CAF/1228
Vest
C2

*conf to
p111*

UNCLASSIFIED

SECURITY CLASSIFICATION OF THIS PAGE(When Data Entered)

Values of target range and course were taken at fixed time intervals from the status registers of the main computer. From these values, differences between actual and fire control solution values were determined and graphically displayed. Additionally, a method for determining probability of counterdetection was derived from the existing sound conditions and plotted as a function of time.

Examples of these profiles, the computer interface schematic diagram, and the software necessary to plot the graphs are provided. Suggestions for further use of such a performance measure are included along with recommendations for other applications.

A

ACCESSION for		
NTIS	White Section	<input checked="" type="checkbox"/>
DDC	Buff Section	<input type="checkbox"/>
UNANNOUNCED		<input type="checkbox"/>
JUSTIFICATION _____		
BY _____		
DISTRIBUTION/AVAILABILITY CODES		
Dist.	AVAIL.	and/or SPECIAL
<i>A</i>		

UNCLASSIFIED

SECURITY CLASSIFICATION OF THIS PAGE(When Data Entered)

FOREWORD

This research and development was conducted in support of Independent Exploratory Development Work Unit ZF61-512-001.03.02 (Human Information Processing). The 21A40 Advanced Submarine Attack Trainer was chosen as a testbed in response to a request from the Commanding Officer, Naval Submarine Training Center, Pacific Detachment (NSTCPAC), San Diego.

Appreciation is expressed to the following personnel of NSTCPAC:

1. CDR A. C. Johannesen, Officer in Charge; LCDR F. L. Gowers; CW04 R. F. Brown; and LCDR D. J. Ohmen for their support and cooperation.

2. G. Steenhagen, DS1; B. J. Downs, TD3; and C. N. Cohea, TD2 for their assistance in 21A40 programming and hardware development.

Appreciation is also extended to Mr. R. Vadnais, Scripps Institute, San Diego, for allowing the Navy Personnel Research and Development Center to use his design for a system computer interface, and to Mr. R. Knowles, San Diego State University, for modifying this interface circuitry.

J. J. CLARKIN
Commanding Officer

BLANK PAGE

SUMMARY

Problem

The Naval Submarine Training Center, Pacific Detachment has expressed an urgent need for reliable, objective performance measurement of submarine fire control parties while they are operating the advanced submarine attack trainer, 21A40. Existing training is evaluated primarily by experienced observers who judge the performance of the approach officer (AO) and the fire control party by the accuracy of their target motion analysis and by weapon hit or miss. A method is needed for providing objective feedback with some qualitative performance measure.

Objective

The objectives of this effort were to design a performance evaluation device, to install it within the advanced submarine attack trainer, and to explore its usefulness. The evaluation device was to use real-time information and to operate independently of the main tactical computer. The output of the device was to serve as an objective measure of training effectiveness that would enhance current methods of post-performance evaluation.

Approach

Real-time, tactical parameters such as target course and range were chosen for use in the performance display system so that performance evaluation could be provided in terms already used by the fire control party. In addition, probability of counterdetection [P(CD)] was included as a measure that is dependent upon both the technology of the target and the approach taken by the AO. This measure is frequently overlooked by tactical trainers, which concentrate exclusively on skills of target motion analysis and weapon employment.

A desktop computer with a graphic screen was chosen as the display device since its stand-alone capability minimized interference with the main computer's functions of problem generation. For realism, the desktop computer sampled geographical and sonar information from the main computer via a binary interface bus. An integrated-circuit board was built to latch and hold the information as well as to respond to desktop computer handshake instructions and address. The desktop sampled values at fixed intervals that were set by the experimenter.

Actual ship-to-target range, fire control system (calculated) range, and the difference between actual and calculated range were plotted as a function of time. Similar profiles were plotted for target course and for P(CD). Copies of these profiles were given to the trainees for use in follow-up critiques and to trainer-operating personnel for their own evaluation.

Conclusions

The profiles were easy to read and gave the trainees a unique view of progress during a simulated submarine approach and attack. An extended period of use by submarine crews operating the trainer will be necessary

to determine the value of this method of performance evaluation. This system has the advantages of portability and flexibility, and there is no interference with ongoing training. The cost of providing this graphics capability was low due to the modularity and ease of interface inherent in a desktop computer.

Recommendations

Development of this evaluation system should be continued and future efforts should be concentrated on examining data for diagnostics under a variety of tactical scenarios. From these data, a composite indicator of tactical proficiency may emerge. In addition, the use of P(CD), in conjunction with the target motion analysis parameters, should be examined as a basis for programming adaptive smart targets.

CONTENTS

	Page
INTRODUCTION	1
Problem	1
Background	1
Objective	2
APPROACH	3
Scenarios	3
Participants	4
Equipment Description	4
Interface Design	4
Data Collection Software	5
Data Summarization Software	7
FINDINGS	11
Instrumentation	11
Usefulness in the Advanced Submarine Attack Training Environment	11
CONCLUSIONS	13
RECOMMENDATIONS	15
REFERENCES	17
APPENDIX A--INTERFACE SCHEMATIC DIAGRAM	A-0
APPENDIX B--DESCRIPTION OF HARDWARE MODIFICATIONS TO THE 21A40 TRAINER	B-0
APPENDIX C--SOFTWARE MODIFICATIONS TO THE 21A40 TRAINER	C-0
APPENDIX D--4051 BASIC PROGRAM FOR AUTOMATIC DATA COLLECTION AND STORAGE	D-0
APPENDIX E--INSTRUCTIONS FOR USING THE TEKTRONIX 4051 WITH THE 21A40	E-0
APPENDIX F--4051 BASIC PROGRAM FOR DATA DISPLAY	F-0
DISTRIBUTION LIST	

LIST OF FIGURES

	Page
1. Status display of tactical performance data	6
2. Target course performance profile	8
3. Target range performance profile	9
4. Probability of counterdetection profile	10

INTRODUCTION

Problem

Submarine tactical team training, as performed in shore-based trainers, can be more effective if it incorporates objective measures of system performance in addition to the dichotomous measures (hit or miss) currently being used. Trainers capable of producing realistic sonar activity offer an opportunity to include new measures based on self noise, target noise, and a variety of sound transmission conditions. While such simulators can generate realistic scenarios, they do not have the programming flexibility needed to explore a variety of information displays that are candidates for performance measurement. Inexpensive desktop computers do have this capability.

Background

Submarine tactical weapons (usually torpedos) are launched following an intense period of target classification, localization, and motion analysis by the submarine fire control team. This team, under the direction of the approach officer (AO), analyzes sensor information and maneuvers the ship until fire control values (i.e., target course, speed, range, and depth) are sufficiently accurate for an intercepting weapon. At the same time, the AO must avoid counterdetection and possible damage to his own ship.

In the past, the submarine's underwater habitat gave it an invulnerability that made counterdetection unlikely until weapons were fired. As long as certain rules were observed, such as avoiding prolonged periscope exposure and active radar or sonar transmission, the submarine had the tactical advantage.

With the advent of nuclear powered submarines, long-range sonars, and high-speed sophisticated weapons, detection and classification are possible at greater distance than ever before. Consequently, submarine-versus-submarine warfare demands increased emphasis on avoiding counterdetection in tactics and tactical training. The new weapons also impose probabilistic factors on the tactical decision process because visual confirmation of target classification and motion is unlikely. New tactics are being developed to take into account the modern sensors and weapons.

Tactical training has been changing in step with tactical development, but problems and deficiencies exist. Sidorsky and Simoneau (1970) emphasized the need for more specific feedback in performance evaluation than the gross hit-or-miss measure that is frequently employed. They also stressed a need for individual decision-making training and training under time constraint. Pesch, Hammell, and Ewalt (1974) reiterated these needs and recommended large-scale decision-training systems; Hammell, Gasteyer, and Pesch (1973) recommended modifications to existing systems for improved performance evaluation and feedback. Finally, Hammell et al. (1973) and Hammell, Sroka, and Allen (1971) stressed providing team trainers with operational and time fidelity, automatic performance measures, and interactive opposition.

The submarine force has recently installed in San Diego a new tactical team trainer, which is designed to provide realistic, computer-driven tactical scenarios. This device, the 21A40 Advanced Submarine Attack Trainer, generates tactical interactions between submarines and surface craft or other submarines via a computer that incorporates realistic sound transmission qualities. It is part of a gradual upgrading of submarine tactical training equipment, which is an outgrowth of more modern ships and weapons.

The 21A40 trainer is used for team training of command and control, sonar, and fire control personnel from STURGEON (SSN 637) and SCAMP (SSN 588) class submarines. It accurately simulates dynamic ocean environments and acoustic conditions, own ship motion control, and both weapons and target characteristics.

Targets, weapons, and own ship can be assigned to independent acoustic processing channels, which attenuate noise levels as a function of range and bathythermal conditions. Thus, the physical conditions of submarine sonar detection and tracking can be simulated with fidelity. However, there is no provision for displaying information for performance evaluation other than by replaying a scenario, or for providing interactive opposition other than through computer-operator intervention.

Therefore, the Naval Submarine Training Center, Pacific Detachment (NSTCPAC), San Diego requested that the Chief of Naval Operations (OP-29) consider incorporating a method of performance evaluation, tactical decision-making training, and interactive opposition (smart target) in the San Diego 21A40 trainer.¹ The Navy Personnel Research and Development Center made a preliminary response to this request and took steps to examine the feasibility of providing these capabilities by a desktop computer that would use information from the main computer without changing or interfering with its operation and configuration.

Objective

The developmental work reported here was intended to meet the following goals:

1. To determine the feasibility of sampling real-time information from a tactical team trainer for storage and subsequent feedback.
2. To provide a display of the information in a form useful to the trainer operators for evaluating training sessions, and to the trainees for evaluating team progress.

¹Naval Submarine Training Center, Pacific Detachment, San Diego
ltr 1500 Ser 127-75, 10 July 1975.

APPROACH

The proficiency of tactical teams historically has been difficult to assess objectively. One reason for this is that the relationship between the outputs of the overall tactical system and of the individual system components is not well understood. If this relationship is to be adequately specified, the behaviors that combine to determine overall system response must be studied.

It is generally recognized that the ultimate index of tactical effectiveness--weapon hit or miss--is not sufficiently diagnostic to provide data useful for performance evaluation. Data are needed that are more sensitive to variations in system output. Since such data are coincident with the activities conducted in support of weapon deployment, they are readily available during training exercises involving the 21A40 simulator.

In the present study, target motion parameters calculated by the fire control team throughout the duration of the training exercises were used as data. A preliminary analysis of these parameters suggested that calculated target range and course were particularly useful for post hoc evaluation of tactical performance. In fact, the evaluation method currently used in training relies heavily on these indices to detect inappropriate tendencies in a team's analysis of target motion.

In addition to quickly and accurately determining the position and motion of the target, the approach officer (AO) must maintain a posture that minimizes the probability of his ship being detected by the target. Consequently, the probability of counterdetection was considered along with the calculated range and course of the target in evaluating tactical team performance. In this way, it was believed that a more complete representation of the actual target engagement situation could be expressed and that an important tactical factor could be added to the evaluation process.

It was highly desirable that the data collection to support this evaluation process not interfere with either the 21A40 trainer or the training procedure itself. As a result, data collection and summarization procedures were designed to function within a flexible module independently of the operation of both the main 21A40 computer and typical training activities. Thus, the entire process supporting AO performance evaluation was intended to be as unobtrusive as possible.

Scenarios

The 21A40 trainer has been primarily employed in developing and in maintaining advanced tactical skills, although it has also been exploited in training related skills, such as navigation. Numerous scenarios have been developed for use with the 21A40 trainer in order to exercise tactical circumstances likely to be encountered by an AO. These scenarios involve various combinations of enemy surface and subsurface vessels opposing own ship (i.e., an SSN 588 or SSN 637 class submarine). The behavior of the enemy ships is prespecified and is dependent on the elapsed time of the exercise. Departures from the scenario script are made at the discretion of the training officer on the basis of own ship's activity and of particular instructional needs. In the present study, no attempt was made to alter

the normal course of the exercise. Data were gathered during scenarios varying considerably in the composition of the enemy force. Surface convoys, individual submarines, and surface convoys supported by submarines were included.

Participants

During the period from July to October 1977, data from three actual submarine tactical teams using the 21A40 simulator were collected. In addition, performance was measured during exercises constructed for training prospective submarine commanding officers.

Equipment Description

The Tektronix 4051 graphics terminal was selected to support the tactical performance evaluation process developed here on the basis of its extreme versatility, compact size, and widespread availability throughout the submarine force. The Tektronix 4051 is a desktop computer with extensive graphics capabilities. It is fully programmable in a modified version of BASIC, which includes extensions to support the graphics functions. Programs and data may be stored on and retrieved from an associated magnetic tape cartridge. In addition, the 4051 may be readily interfaced with other computers via the data communication interface or with miscellaneous peripheral devices via the general purpose interface bus (GPIB).

A critical issue in instrumenting an A0 performance evaluation procedure concerns the availability of relevant data. Target motion analysis and sonar data are resident in the 21A40 trainer, which simulates the ocean environment and which is controlled by the UYK-7 computer. Since the 4051 was intended as the vehicle for the performance evaluation, an effective interface between these computers was necessary. The GPIB was chosen as the means by which to accomplish this interface with minimal modifications to the 21A40 system.

Interface Design

To maximize the ease of use and the flexibility of the interface between the 4051 GPIB and the 21A40, a design was developed to conform to IEEE Standard 488-1975. A schematic diagram of an interface designed for a similar application was acquired from the Scripps Institute, San Diego and was examined within the 21A40 system. Significant revision of this initial design was required to permit multiple 8-bit bytes to be concurrently sampled from the 21A40 and to eliminate a considerable amount of extraneous circuitry. A schematic diagram of the resulting circuitry is provided in Appendix A. Although this circuit is potentially capable of sampling numerous 8-bit data bytes, it is presently designed to accommodate only the five bytes representing the data used in this study.

Some modification to both the hardware and the software of the 21A40 trainer was required to support the interface with the 4051 GPIB. These modifications are documented in Appendices B and C, respectively. Basically, these alterations involve directing the specified data to a circulating storage card that resides in the 21A40. From this card, the data are

serially loaded into particular locations of two discrete storage cards that are wired to the GPIB interface circuitry. The contents of these discrete storage locations are updated each second and are transferred to the GPIB only when addressed by the 4051. Consequently, the 4051 may access valid data at any desired sampling rate.

Data Collection Software

A program was developed to run on the 4051 that would automatically collect and store data relevant to the AO's tactical performance. The data used in this study were (1) the true range and course of the target, (2) the range and course of the target as calculated by the fire control party, and (3) the signal/noise ratio for ship as measured at the target. These data were provided to the 4051 via the GPIB interface, which is discussed above and is addressed as peripheral device 40. A complete listing of this program is provided in Appendix D.

Although this data collection program functions automatically, some operator intervention is required, particularly during initialization. A set of instructions that describes how to use this tactical data collection program has been prepared and appears in Appendix E. After the program is loaded into the 4051, an operator is required to specify several parameters and to select a data sampling rate from a menu that appears on the screen. In addition, he must provide the program with an appropriate indication of the target ship's passive sonar sensitivity by entering estimated values for the mean and standard deviation of the target ship's recognition differential. Although these parameters could have been automatically selected on the basis of target ship classification, sonar sensitivity information was not stored in order to keep the program itself unclassified.

Once these parameters have been entered and the scenario has been initiated, the program may be left unattended until the termination of the training exercise. At this point, the operator should press a special function key to signal the end of the exercise. Another function key, which has been provided to act as an event marker, may be used to mark the time of occurrence of any significant event, such as weapon deployment.

Throughout the training exercise, a status display of the AO's tactical performance data is provided on the 4051's screen. This feature enables transient observers to review momentary fluctuations in the tactical team's performance while the scenario is still in progress. Figure 1 provides an illustration of this status display.

```

TRUE RANGE = 2790
TRUE COURSE = 62
S/N = -18
P(CD) = 18
F/C RANGE = 9100
F/C COURSE = 185
SAMPLE # = 64

TRUE RANGE = 2550
TRUE COURSE = 62
S/N = -16
P(CD) = 25
F/C RANGE = 9110
F/C COURSE = 185
SAMPLE # = 65

TRUE RANGE = 2380
TRUE COURSE = 62
S/N = -14
P(CD) = 32
F/C RANGE = 7000
F/C COURSE = 185
SAMPLE # = 66

TRUE RANGE = 2220
TRUE COURSE = 62
S/N = -13
P(CD) = 36
F/C RANGE = 6060
F/C COURSE = 82
SAMPLE # = 67

TRUE RANGE = 2200
TRUE COURSE = 62
S/N = -9
P(CD) = 54
F/C RANGE = 3900
F/C COURSE = 11
SAMPLE # = 68

TRUE RANGE = 2300
TRUE COURSE = 62
S/N = -6
P(CD) = 67
F/C RANGE = 1950
F/C COURSE = 11
SAMPLE # = 69

TRUE RANGE = 2500
TRUE COURSE = 62
S/N = -9
P(CD) = 54
F/C RANGE = 2100
F/C COURSE = 11
SAMPLE # = 70

```

Figure 1. Status display of tactical performance data.

Data Summarization Software

Following the conclusion of a training exercise, the operator is given the option to immediately rerun the data collection sequence, to examine the data just gathered, or to terminate all subsequent activity. Under most circumstances, the operator will elect to examine the data. In this case, the 4051 is automatically routed to another program that retrieves the performance data and plots profiles of these data across the period of the exercise. A listing of this program, which may be accessed independently of the data collection program, is provided in Appendix F.

At the request of the operator, this program will retrieve and display data about target course, target range, or probability of counterdetection [P(CD)]. For target course and range, both absolute and difference plots of the actual and calculated values are presented. As seen in Figures 2 and 3, which illustrate typical performance profiles for target course and range respectively, both of these profiles are plotted as a function of time. The scale of these plots is varied automatically, depending upon the numbers of samples taken and the data values observed. In the upper plots, the solid line shows the true behavior of the target, and the dotted line reflects the calculations by the fire control team. The lower plots are simply the differences between these data; that is, the target motion analysis error. The upwards pointing arrow is an event marker, which, in this case, reflects the firing of a torpedo salvo.

In addition to the target course and range profiles, fluctuations in P(CD) throughout the training exercise may be displayed. As shown in Figure 4, which presents a typical P(CD) profile, the basic structure of these plots is similar to those for course and range. However, the upper plot in Figure 4 depicts the signal/noise (actually signal excess) conditions as measured at the target ship throughout the scenario. The lower plot is simply a Gaussian transformation of the signal/noise profile that permits P(CD) to be more readily observed:

$$P(CD) = .5 + .5 (1 - e^{-2x^2/\pi})^{.5} \quad (1)$$

where x = signal excess

One of the anticipated benefits of these performance profiles involves the fact that they are almost immediately available following the completion of a training exercise. Consequently, they may be used in the critique that is typically held after the close of each scenario. To promote their use by all participants in these critiques, hard copies of each performance profile for the preceding training session were provided to the trainees as well as to the training personnel. These copies were made using a hard copy unit that is compatible with the 4051, such as the Tektronix 4631.

TARGET COURSE PROFILE FOR SESSION 5
--- TRUE COURSE ...FC COURSE 1 DIVISION = 10 DEGREES

348

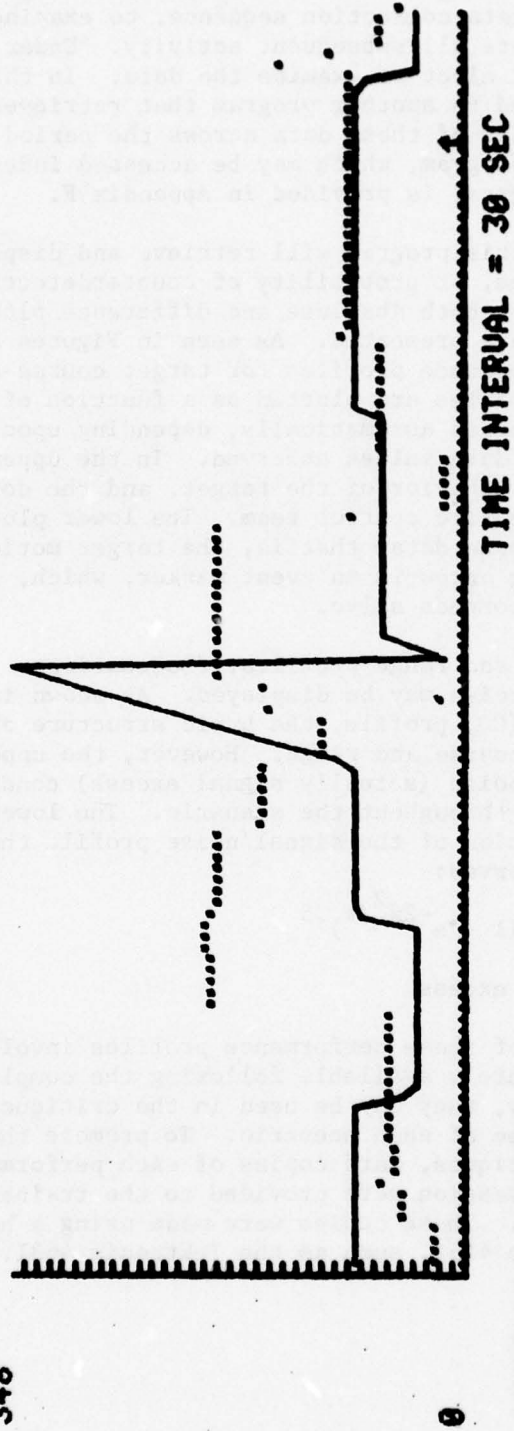

DIFFERENCE VALUES

180

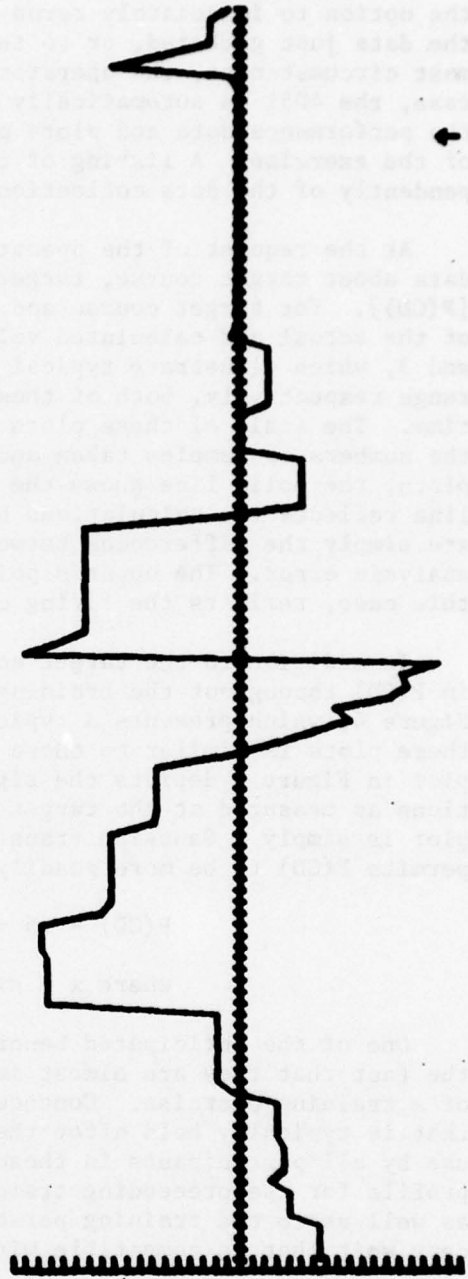
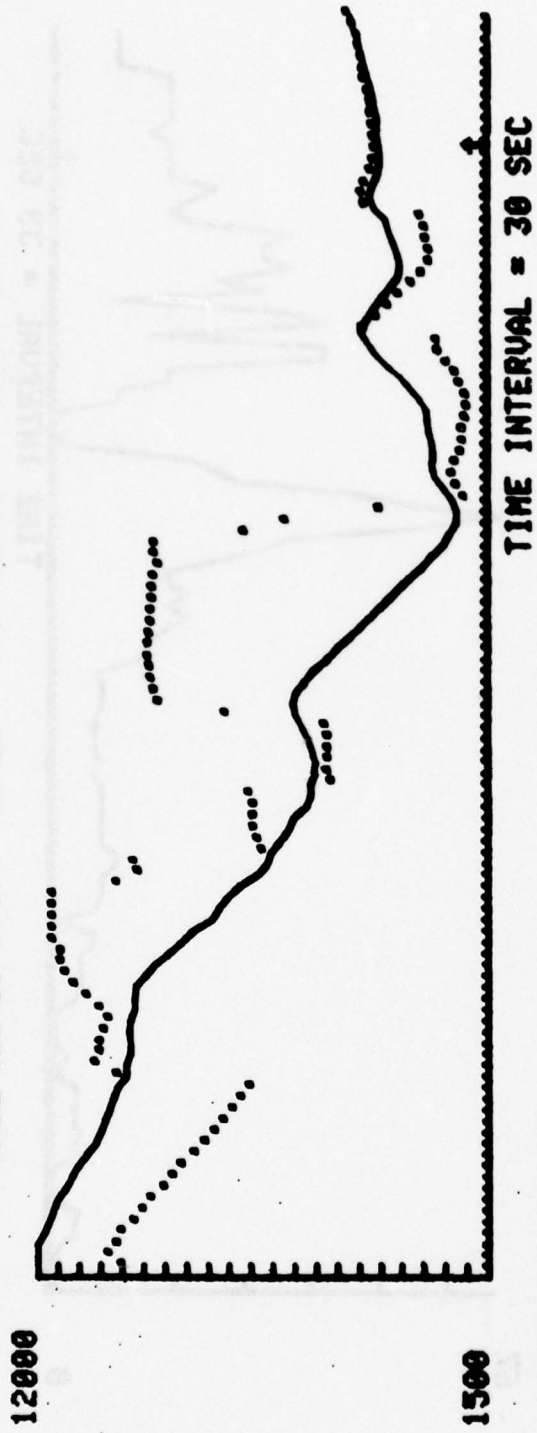

Figure 2. Target course performance profile.

TARGET RANGE PROFILE FOR SESSION 5
---TRUE RANGE ...FC RANGE 1 DIVISION = 500 YDS



9

DIFFERENCE VALUES

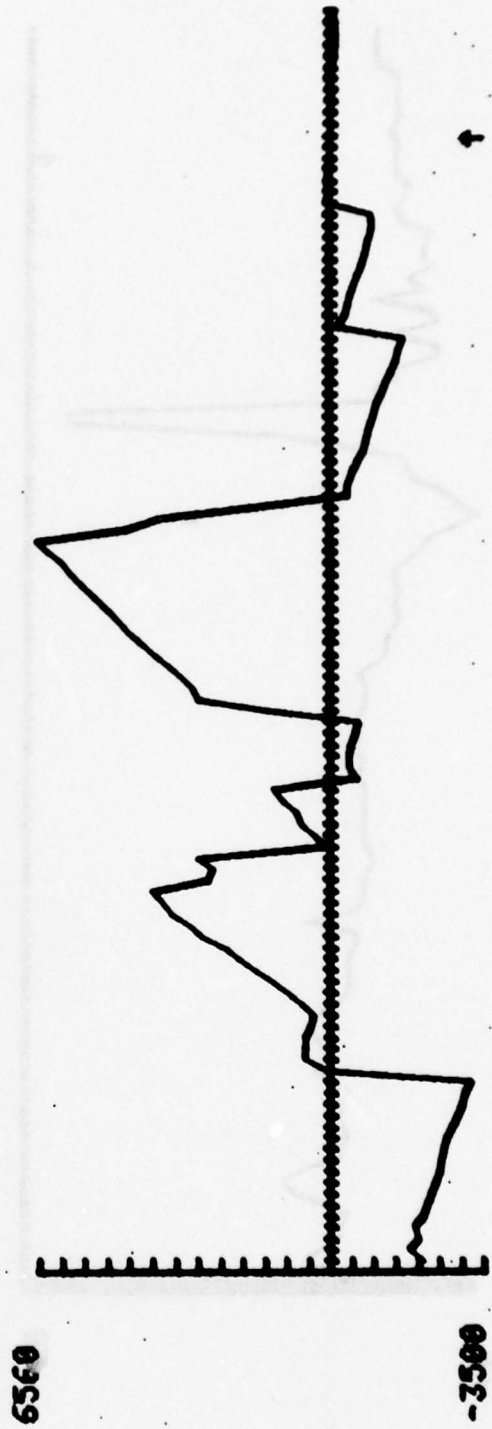

Figure 3. Target range performance profile.

SIGNAL/NOISE PROFILE FOR SESSION 5 TIME INTERVAL = 30 SEC



PROB OF COUNTERDETECTION PROFILE FOR SESSION 5



Figure 4. Probability of counterdetection profile.

FINDINGS

It should be emphasized that the present examination of procedures for measuring the proficiency of the approach officer (AO) is preliminary. The performance profiles used here are intended as a first step towards the development of a meaningful scheme for performance evaluation. Ultimately, advances in evaluating submarine AO performance are expected also to provide information about ways to adaptively augment training by the use of smart (interactive) targets and to aid the AO in making tactical decisions.

Instrumentation

A major goal of the present effort was to implement an accurate and reliable means for gathering data relevant to the AO's tactical performance. The interface that was developed to link the 4051 and the 21A40 has provided this capability. Since its implementation, no incorrect data have been transferred to the 4051. However, since the data bytes are expressed in only 8-bits, some imprecision is introduced. Target range and course data are accurate within 125 yards and 1.4°, respectively. Exact signal/noise data are transferred. The data collection interface required minimal modification to the existing 21A40 system and operates almost entirely unobtrusively.

The use of the 4051 as an intelligent, external module to the 21A40 trainer enables the system to be extremely flexible. Modifications to the existing performance measurement procedures may be made easily, and new features may be readily adopted and tested.

One limitation concerning the operation of this data collection interface has been encountered. Due to restrictions within the 21A40 system, the data collection interface may only be activated when the trainer is in combined mode. That is, to get meaningful probability of counterdetection (P(CD)) data, the two attack centers within the trainer must be linked to the same scenario. Consequently, P(CD) data cannot presently be collected while both attack centers in the 21A40 trainer are operating independently.

Usefulness in the Advanced Submarine Attack Training Environment

The informal reactions from the trainers and trainees who have used the tactical performance profiles developed here have been favorable. Numerous tendencies that characterize a tactical team's performance may be detected easily and examined quantitatively. It is clear, however, that the value of this method of performance evaluation must be determined as a result of an extended period of use by submarine crews operating the trainer.

An illustration of the types of information that may be accumulated via this procedure may be seen in Figures 2, 3, and 4. The scenario represented by these figures involved an SSN 637 as own ship versus a snorkeling FOXTROT-class Soviet submarine. The peak in the true course shown in the upper plot of Figure 2 reflects a circular movement by the target. Several typical performance characteristics may be observed in Figures 2 and 3. A rather gratifying tendency towards a small error in the calculated target parameters may be seen to develop as the exercise proceeds. At the

point of weapon deployment, signified by the arrow, the fire control team's range and course calculations are quite accurate. Another general tendency that may be seen in these figures involves the discrete, oscillatory nature of the adjustments that the fire control team make in their target motion analysis. This behavior appears to be a result of standard procedures and of the time delays inherent in the analysis of target motion.

The signal/noise profile in Figure 4 reflects the sound transmission from own ship to the target. Throughout most of the exercise, the sound conditions were relatively stable, resulting in a very small P(CD). However, about two-thirds of the way through the scenario, a relatively small increase in the signal/noise may be seen to result in a dramatic increase in P(CD). At this point, the AO was unaware that his posture relative to that of the target could have resulted in a counterdetection. Such information has certainly been of assistance in advising AOs of the consequences of their own maneuvers. The precipitous drop in signal/noise that may be noted in Figure 4 is a result of own ship moving into the baffles of the target. These marked discontinuities are clearly apparent in the data and are indicative of the use of advantageous tactics.

These observations are suggestive of several approaches that might be taken to develop more unitary and diagnostic indices of tactical proficiency. In particular, useful composite performance measures might be devised based on such factors as (1) the time for the fire control team to recover from a target's change in course, (2) the time to achieve an overall target motion solution that lies within the corrective tolerance of the weapon, (3) the oscillation magnitude of subsequent target motion solutions, and (4) the level of P(CD). The most likely possibility for the development of such a composite measure of tactical team performance involves the development of a multiple regression model. In any case, a considerable amount of data from a wide variety of scenarios must be gathered to support the construction of such a performance evaluation index. The general procedure that has been described in this report enables such a data base to be easily accumulated and interrogated.

In exercising the present AO performance evaluation process, several limitations have become apparent. In particular, the current procedure is capable of dealing with the data from only one target. In many scenarios, it is entirely reasonable to require data from several targets to be gathered simultaneously. For instance, if own ship encountered an enemy convoy, the P(CD) from several escorts should be monitored as the AO maneuvers his submarine. As subsequent, more sophisticated performance evaluation procedures are developed, the ability to handle multiple targets will certainly be addressed.

Another limitation which has been observed concerns the usefulness of P(CD) as a performance measure. Due to the inherent sonar sensitivities and noise emission patterns of surface ships, U. S. Navy submarines are normally quite difficult to detect. Consequently, the diagnosticity of P(CD) is largely constrained to passive sonar submarine-submarine encounters. Although this is in itself a valuable contribution, another means should be developed for evaluating own ship posture during encounters with surface ships with active sonars.

CONCLUSIONS

The procedure and supporting instrumentation reported here has been demonstrated to provide an effective means for tactical performance measurement of the approach officer (AO) and the fire control team. However, the extent to which the performance evaluation system influences tactical training remains to be seen. Regular use under a variety of scenarios will provide a basis for revisions to and subsequent extensions of the present procedure. As such changes are indicated, they may be readily and inexpensively incorporated.

Once a particular data set and display format are adopted, they may be examined for diagnosticity under a wide variety of tactical scenarios. Examples of data with potential diagnostic value include: (1) time to arrive at a weapon-compatible solution without exceeding a prespecified counterdetection probability, (2) length of time an AO can maintain a low counterdetection profile while remaining within weapon range and maintaining satisfactory target motion analysis, and (3) time interval between target course or speed change and satisfactory motion analysis (i.e., zig recovery time). These data may be combined into a polynomial expression to provide a composite indication of tactical proficiency.

These same data also may offer a means of providing more interactive opposition during advanced tactical training. Particularly through the probability of counterdetection ($P(CD)$) measure, it is possible to trigger changes in target maneuvers and intentions. Given an adequate $P(CD)$, a smart target could be programmed to evade or counterattack. Changes in target actions thus could be substantiated by the posture adopted by the AO, his tactical skills, and the proficiency of the fire control team.

The modular structure of the present procedure has several advantages in system design and flexibility. It may be readily expanded to include new developments in training evaluation, such as those described above, or to support additional equipment without disturbing other segments of the system. It also might be incorporated into submarine attack trainers other than the 21A40. Conversely, it could also be disconnected from the system with minimal expense and time. The portability of this performance measurement module also permits its use at remote sites. For instance, it might be used on board submarines with digital computer fire control systems, such as the MK 117.

RECOMMENDATIONS

Based on the results of this study, the following recommendations are made:

1. Development of this evaluation system should be continued, directing future efforts toward examining data for diagnosticity under a variety of tactical scenarios. From these data, a composite indicator of tactical proficiency may emerge.

2. The use of probability of counterdetection, in conjunction with the target motion analysis parameters, should be examined as a basis for programming adaptive targets.

BLANK PAGE

REFERENCES

Hammell, T. J., Gasteyer, G. E., & Pesch, A. J. Advanced officer tactics training device needs and performance measurement technique (NAVTRADEVCCEN Tech. Rep. 72-C-0053-1). Groton, CN: General Dynamics EB Division, 1973.

Hammell, T. J., Sroka, F. P., & Allen, F. L. A study of training device needs for meeting basic officer tactics training requirements (NAVTRADEVCCEN Tech. Rep. 69-C0140-1). Orlando, FL: Naval Training Equipment Center, March 1971.

Operation and maintenance instructions for advanced submarine attack trainer, 21A40 (NAVTRADEVCCEN Publication No. 4014). Orlando, FL: Naval Training Equipment Center, June 1975.

Pesch, A. J., Hammell, T. J., & Ewalt, F. M. Tactical decision making training system design (NAVTRAEQUIPCEN Tech. Rep. 73-C-0158-1). Orlando, FL: Naval Training Equipment Center, November 1974.

Sidorsky, R. C., & Simoneau, G. Decision-making study: Final report 1. An experimental evaluation of TACTRAIN: An approach to computer-aided tactical decision-making training (NAVTRADEVCCEN Tech. Rep. 1329-4). Orlando, FL: Naval Training Device Center, March 1970.

APPENDIX A
INTERFACE SCHEMATIC DIAGRAM

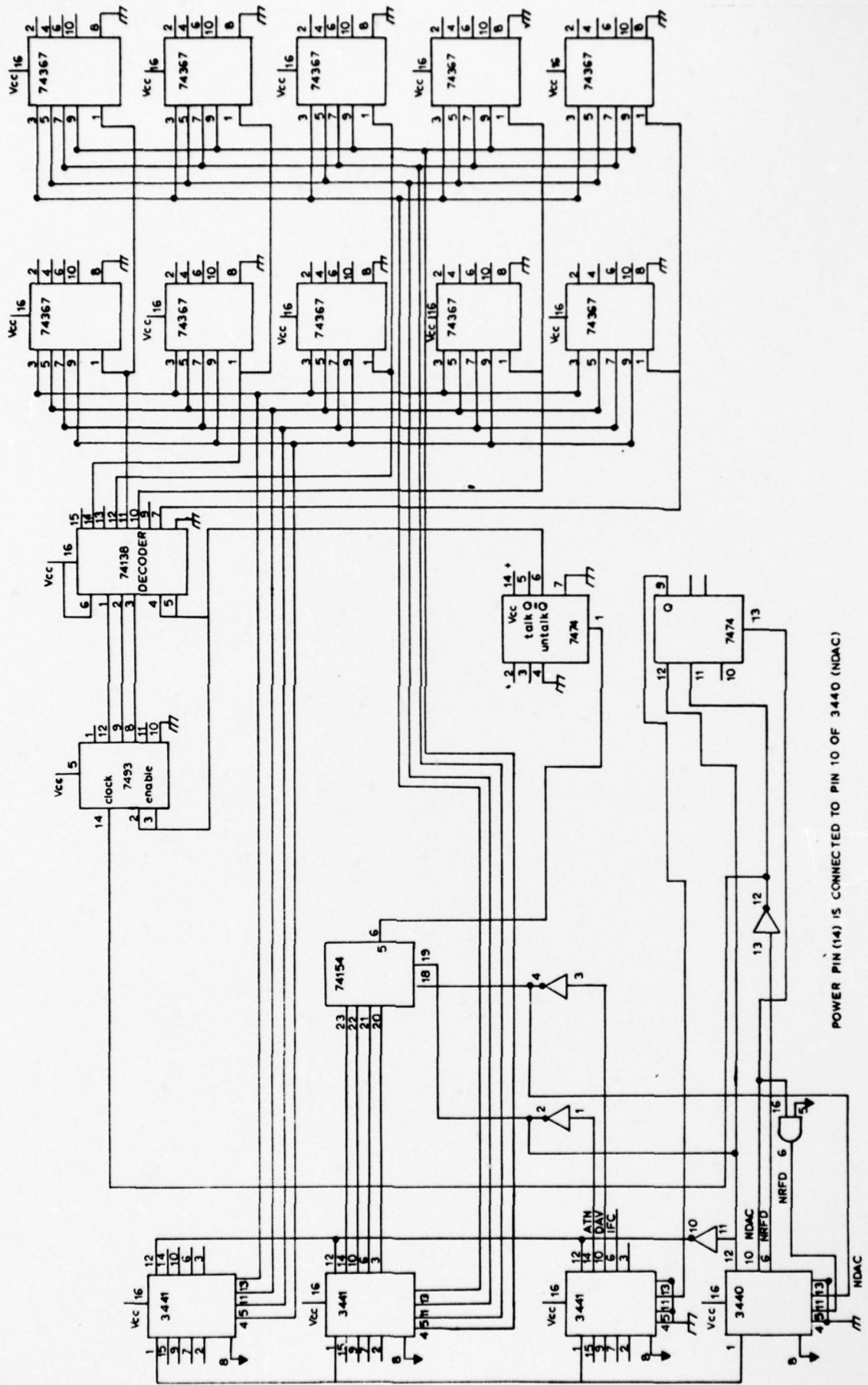

POWER PIN (14) IS CONNECTED TO PIN 10 OF 3440 (NDAC)

Figure A-1. Schematic diagram of GPIB interface card.

APPENDIX B
DESCRIPTION OF HARDWARE MODIFICATIONS
TO THE 21A40 TRAINER

DESCRIPTION OF HARDWARE MODIFICATIONS
TO THE 21A40 TRAINER

The Tektronix 4051 samples 21A40's real-time program by fetching fire control range and course, true range and course, and signal-to-noise ratio of any target specified with the 21A40 operator command PD1, PD2, PD3, etc. up to PD8. These data are first stored in the acoustic data processor's (ADP) self-band amplitude (SBA) output block. The five 8-bit words are then tapped off of ADP data fan-out at the input of card 9A1A2A117 (Figure B-1), sent to an existing circulating storage card 9A1A2A325 (Figure B-2), and latched up with load pulse 115, which loads 64 words of SBA data. (PROBDET data is loaded in byte 3 of SBA, which is unused.) The data is then stored in two new discrete storage cards, 9A1A2A101 and 9A1A2A116, each of which is capable of storing four 8-bit words. From timing distribution 9A1A2A417 (Figure B-3), word times are routed to the two new discrete storage cards (Figures B-4 and B-5).

Word time 55 in the hardware corresponds to the first word stored in ADP's SBA output block; word time 56, to the second word; word time 57, to the third word, etc. up to word time 59, which corresponds to the last word in the output block. The first four words go to discrete storage 9A1A2A101, and the last word time goes to discrete storage 9A1A2A116. The PROBDET data is then left hanging on the outputs of the discrete storage cards (four 8-bit bytes on one card, and one 8-bit byte on the other). Additional details on Figures B-1 through B-5 may be found in NAVTRADEV Publication No. 4014, 1975.

The output of the discrete storage cards (in bytes) are then connected to an interface card (9A1A2A412 in Appendix A), which receives up to five bytes of data, and serially transfers the data to a Tektronix 4051 desktop computer for analysis during the running of a problem. At the end of a problem, profiles of the differences between the true and the fire control solution for range and for course are plotted for performance during that exercise. In addition, similar profiles of signal-to-noise ratio and probability of counterdetection were displayed for use in the performance critique.

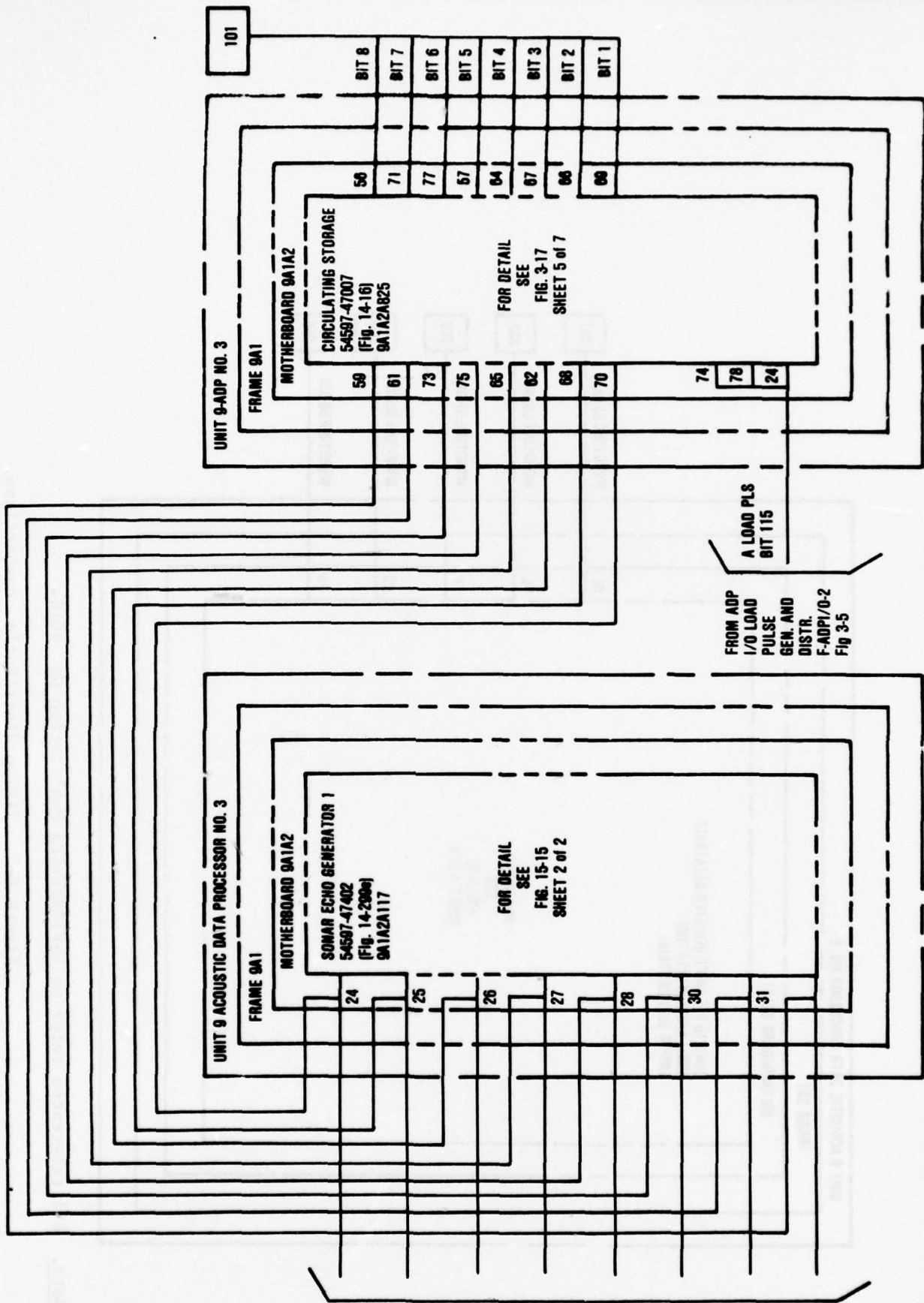

B-3

FROM ADP
FAHOUT
9A1A2A201
FIG 3-17
Sheet 2 of 7

Note. All references refer to NAVTRAVEVCEN Publication No. 4014.

Figure b-2. Detail of connections between sonar echo generator and circulating storage card.

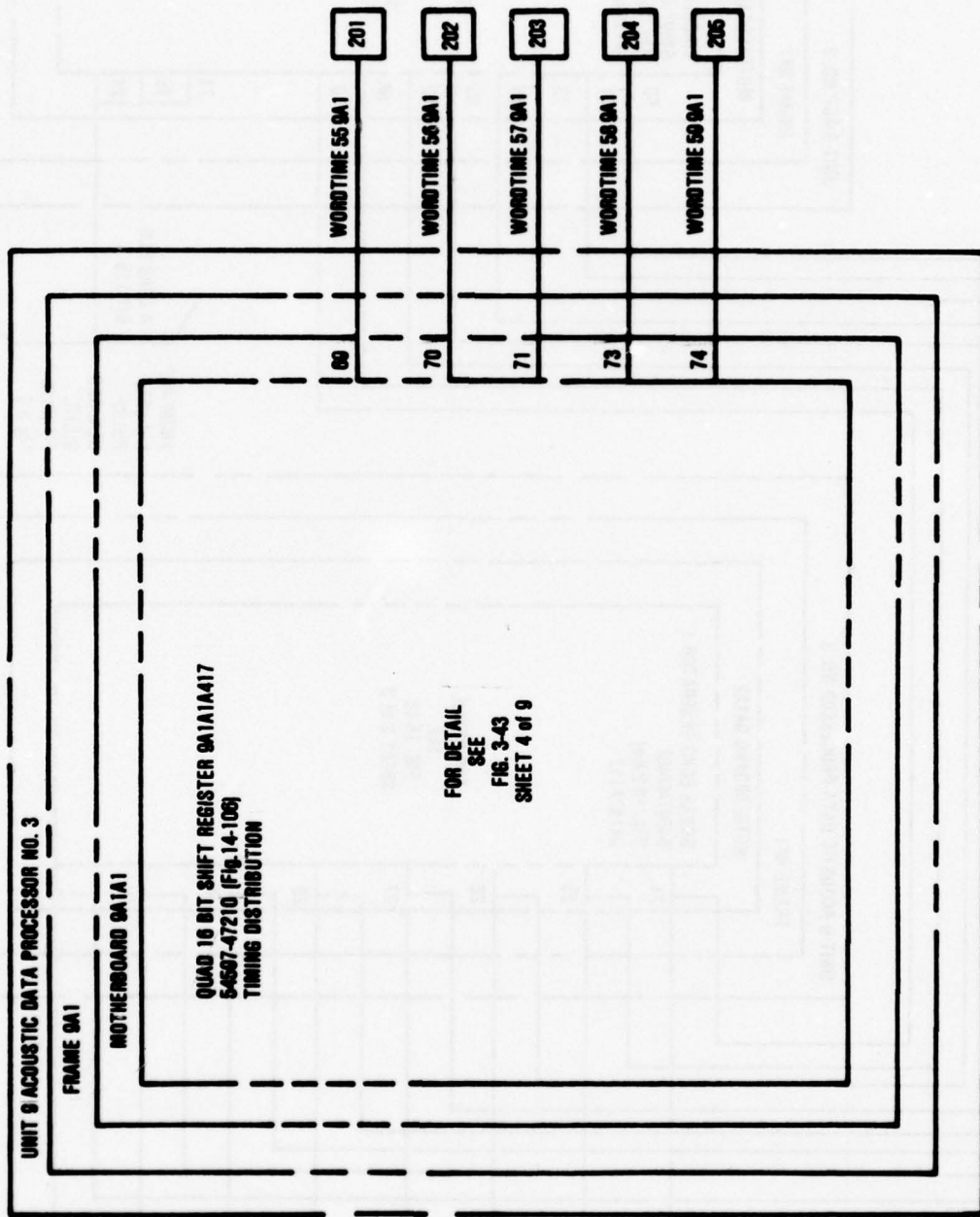

Note. All references refer to NAVTRADEVEN Publication No. 4014.

Figure B-3. Timing distribution connections.

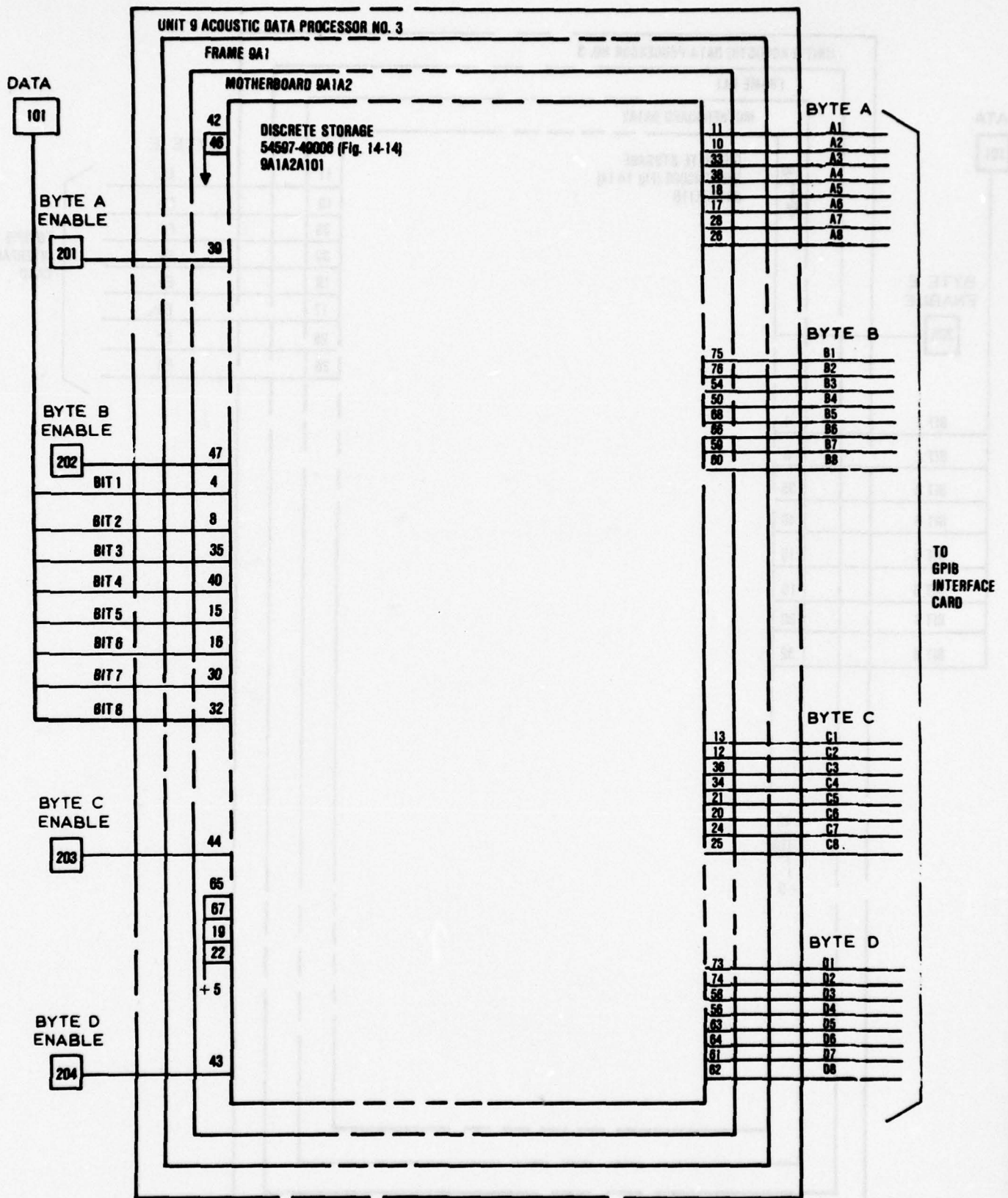

note. All references refer to NAVTRADEVCEV Publication No. 4014.

Figure B-4. First discrete storage card connections.

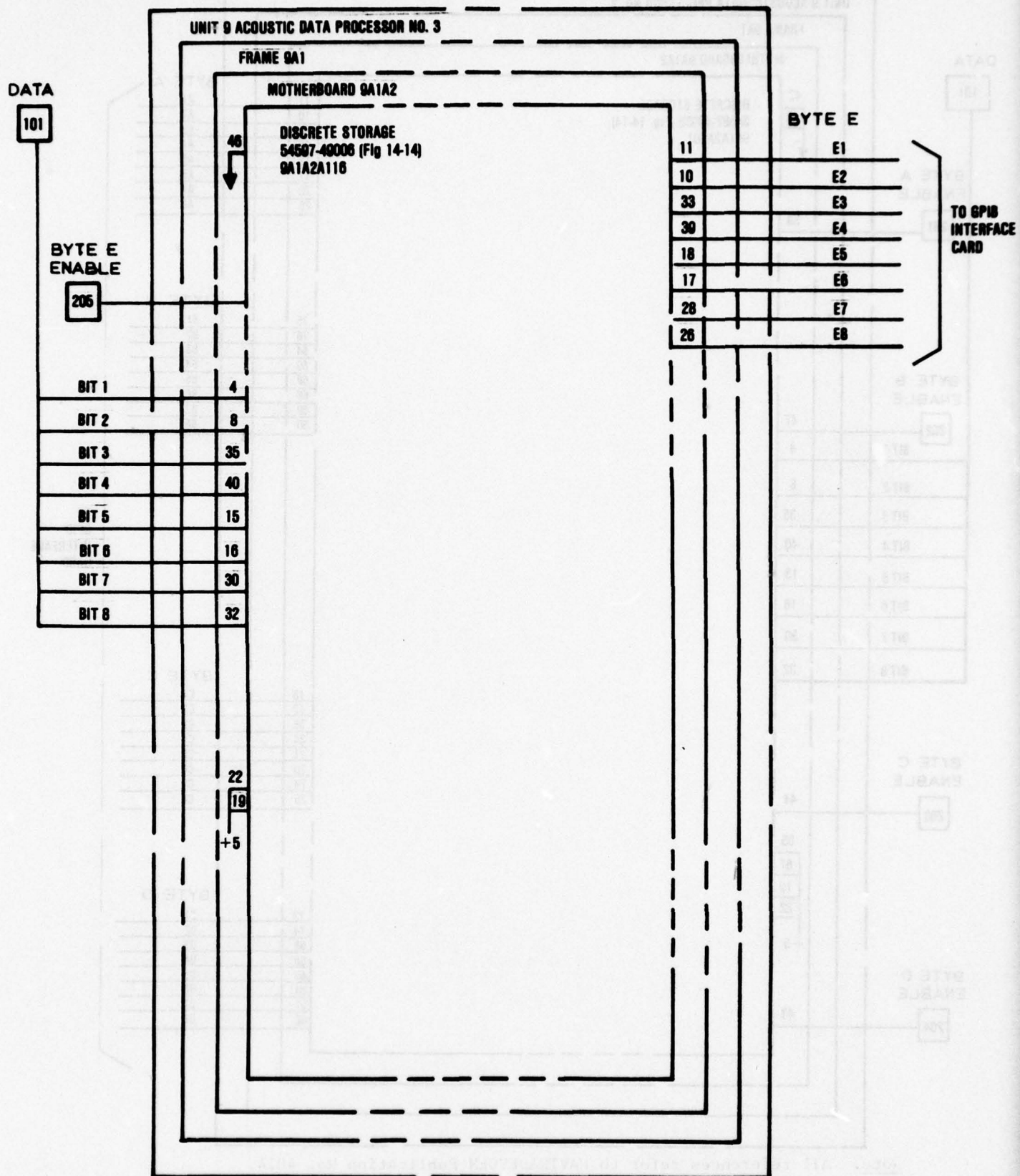

Note. All references refer to NAVTRADEVCCEN Publication No. 4014.

Figure B-5. Second discrete storage card connections.

APPENDIX C

SOFTWARE MODIFICATIONS TO THE 21A40 TRAINER

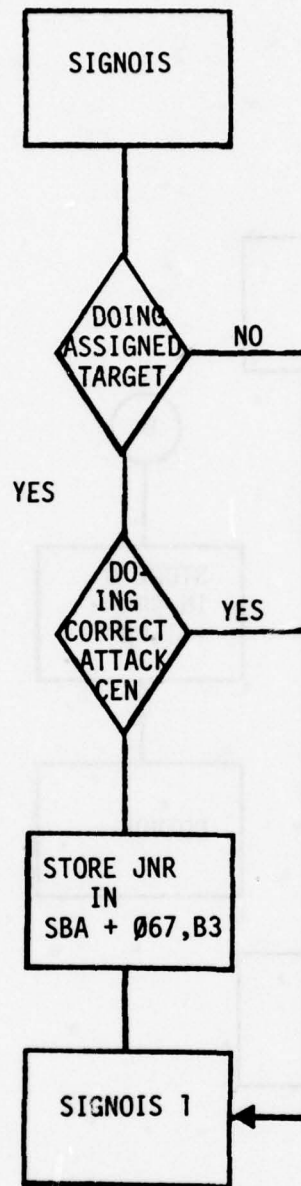

Figure C-1. Prob. det. SNR routine.

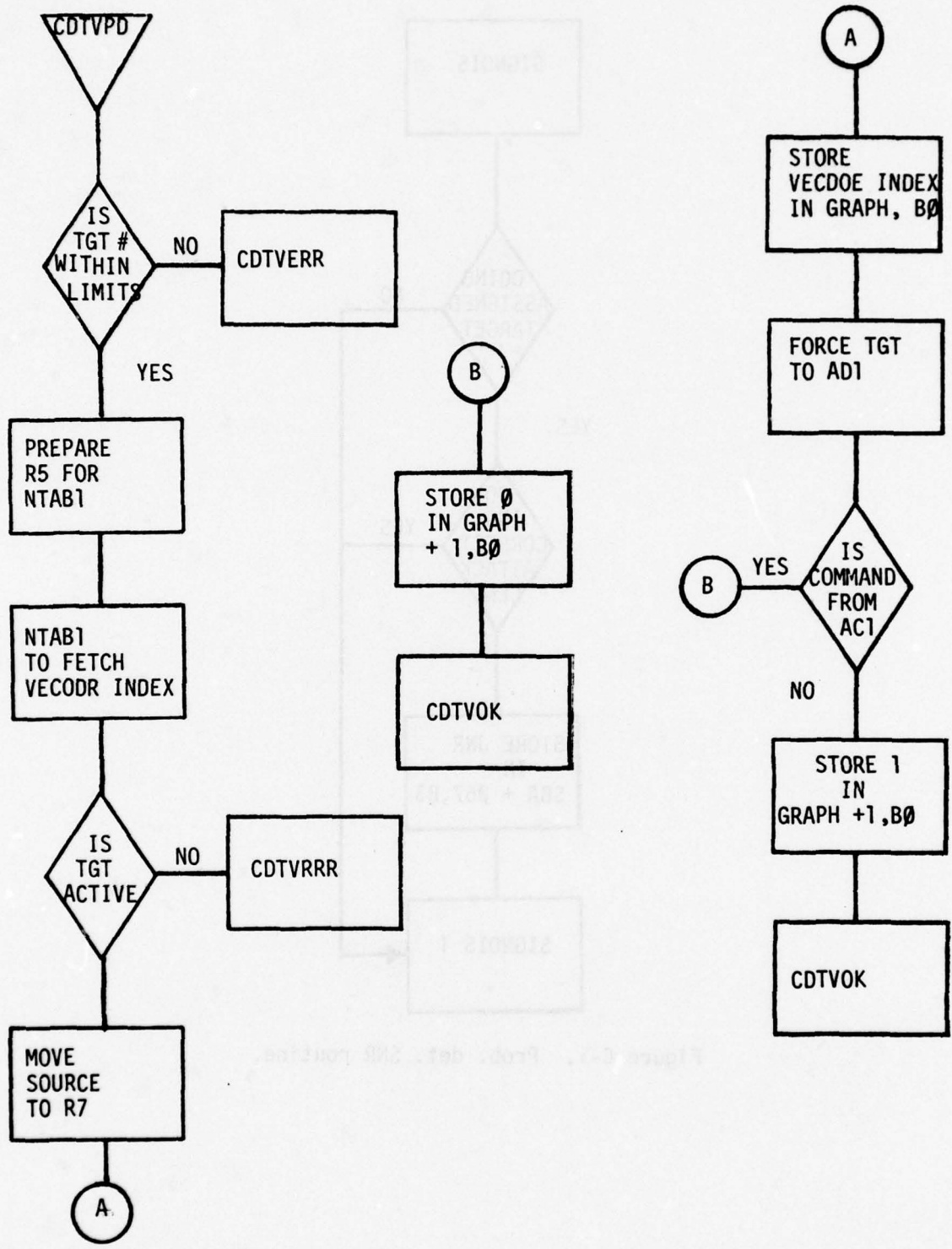

Figure C-2. Prob. det. transvector (TV) routine.

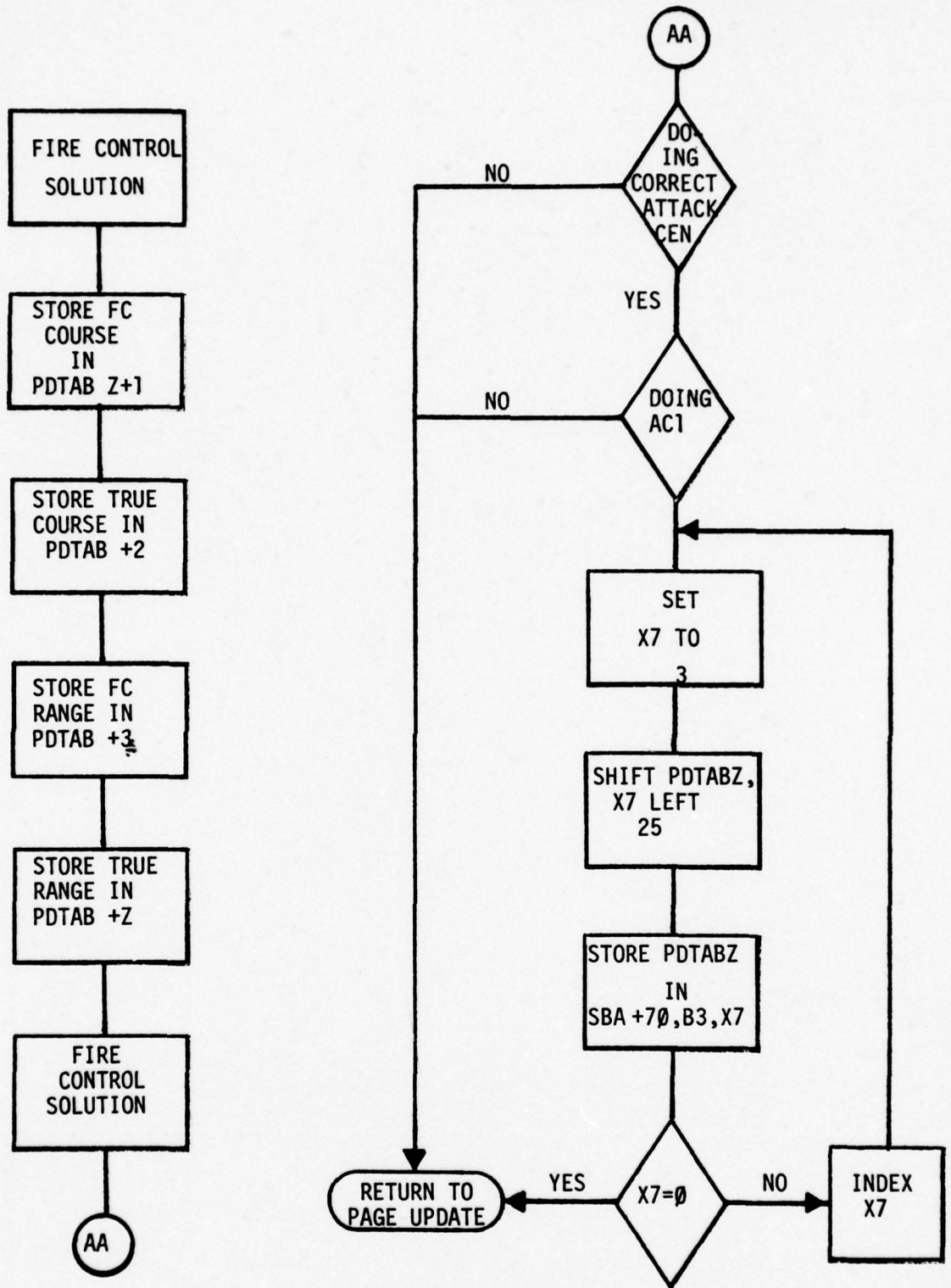

Figure C-3. Prob. det. data acquisition routine.

APPENDIX D

4051 BASIC PROGRAM FOR AUTOMATIC DATA COLLECTION AND STORAGE

4051 BASIC PROGRAM FOR AUTOMATIC DATA COLLECTION AND STORAGE

```

1 RUN 100
4 T5(I0)=X
5 I0=I0+1
6 RETURN
20 F9=1
21 RETURN
100 REM-----HSTOPAC STUDY PHASE 1-----
110 REM-----AUTOMATIC DATA COLLECTION PROGRAM-----
120 INIT
130 SET KEY
140 PAGE
150 DIM T5(10)
160 T5=0
170 I0=1
180 PRINT "ENTER SESSION NUMBER"
190 INPUT T
200 T=T+3
210 PRINT "1 = 30 SECONDS"
220 PRINT "2 = 1 MINUTE"
230 PRINT "3 = 3 MINUTES"
240 PRINT "4 = 5 MINUTES"
250 INPUT T8
260 INPUT T8
270 GO TO T8 OF 280,300,320,340
280 T9=6420
290 GO TO 350
300 T9=12819
310 GO TO 350
320 T9=38368
330 GO TO 350
340 T9=63654
350 PRINT "HAS THIS FILE BEEN MARKED?--YES OR NO"
360 INPUT T$
370 IF T$("<>")="NO" THEN 390

```

```

380 GOSUB 1080
390 FIND T
400 PRINT "ENTER RECOGNITION DIFFERENTIAL & STANDARD DEVIATION"
410 INPUT R9,S9
420 PRINT "PRESS RETURN KEY TO BEGIN...."
430 INPUT C$
440 PAGE
450 F9=0
460 X=0
470 REM---AUTO INPUT OF S/N, TRUE AND FC COURSE AND RANGE
480 SET NOKEY
490 MBYTE @84:
500 RBYTE M0,@9,D1,D2,R1,R2
510 MBYTE @95:
520 D1=INT(1.41*D1)
530 D2=INT(1.41*D2)
540 R1=R1*125
550 R2=R2*125
560 X=X+1
570 IF X=0 THEN 760
580 PRINT "TRUE RANGE = ";R1," "; "F/C RANGE = ";R2
590 PRINT "TRUE COURSE = ";D1," "; "F/C COURSE = ";D2
600 SET KEY
610 M2=255-M0
620 IF M2<=128 THEN 650
630 M1=255-M2
640 GO TO 660
650 M1=128-(128+M2)
660 REM---TRANSFORM S/N TO P(CD)
670 M3=(M1-R9)/S9
680 P0=0.5+0.5*(1-EXP(-2*M3^2/PI))^0.5
690 IF M3<0 THEN 720
700 P1=INT(P0*100)
710 GO TO 730
720 P1=INT((1-P0)*100)

```

APPENDIX E

INSTRUCTIONS FOR USING THE TEKTRONIX 4051
WITH THE 21A40

INSTRUCTIONS FOR USING THE TEKTRONIX 4051
WITH THE 21A40

The Tektronix 4051 is being used as part of a system to help evaluate the tactical performance of the approach officer (AO) and the fire control team during training exercises in the 21A40. To support this evaluation process, the 4051 automatically samples range, course, and signal/noise data from the 21A40. However, before this process may begin, both the 21A40 and the 4051 must be initialized. A few preparatory activities are required to complete this initialization.

Selecting the Training Problem

During typical usage of this system, the training officer selects the problem to be used. The parameters of the training problem, which specify the own ship, target, and ocean conditions, are documented and are entered into the 21A40 via standard procedures using one of the associated terminals. These procedures, along with representative values of the scenario parameters, are outlined below.

1. Specify the type of own ship to be used as well as its speed, course, and depth. By entering each of the following commands sequentially, own ship will be identified as an SSN 637 moving at a velocity of 10 knots, on a course of 090°, and at a depth of 190 feet.

- a. OS1, TYP, SSN 637
- b. OS1, VEL, 10
- c. OS1, CS, 090
- d. OS1, D/A, 190
- e. OS1, A/D

2. Specify the type of target to be used as well as its position from own ship, its course, and its speed. The following commands will generate a DD 1-class target at an initial range and bearing from own ship of 15,000 yards and 030°, respectively. This target will be traveling on a course of 120° at a speed of 10 knots.

- a. TG1, TYP, DD1
- b. TG1, POO, 15000, 030
- c. TG1, CS, 120
- d. TG1, VEL, 10
- e. TG1, A/D

3. Specify the type of ocean to be used. Ocean conditions are determined by the depth and type of bottom, the sound velocity profile (which reflects water conditions affecting sound transmission, such as salinity, temperature, etc.), and the sea state. For example, a rock bottom at 12,500 feet with a sound velocity profile of 6 and a sea state of 2 would be activated by entering the following commands.

- a. BMR, 12500
- b. SVP, 6
- c. SS, 2
- d. GO

Default ocean parameters may be activated by simply entering the command GO. This will automatically define an ocean with a rock bottom at a depth of 25,000 feet with sound velocity profile of 0 and a sea state of 0.

4. Determine which target will be analyzed by attack center 1. Enter PD along with the appropriate target number. For instance, if attack director 1 will be analyzing target 1, then enter PD1.

Activating the 4051 Data Collection Program

1. Turn on the 4051 by pressing the switch under the right side of the keyboard.
2. Press the HOME/PAGE key in the upper left of the keyboard.
3. Firmly press the tape cartridge into slot. The metal side should be on the right side.
4. Consult the Session Log located near the 4051 and fill in the necessary information (date, problem number, etc.).
5. Enter the number of the upcoming session (from the Session Log) into the 4051 and then press the RETURN key.
6. Select a sampling rate from those shown on the 4051's screen that seems appropriate to the upcoming problem (if you are not sure, select 30 seconds). Enter the number corresponding to this sampling rate and press RETURN.
7. In response to the question "Has this file been marked?", which will appear on the 4051 screen, type NO and press RETURN.
8. Enter a recognition differential and a standard deviation that are appropriate for the target's sonar sensitivity in the upcoming problem. If you are not sure of appropriate values, consult the training officer. Press RETURN after entering each of these values. For example, you might enter -10 and then press RETURN, followed by 9 and then RETURN.

Initiating the Problem

1. At the direction of the training officer, initiate the problem by entering RUN on a 21A40 terminal.
2. Make sure that one of the 21A40 alphanumeric terminals is displaying PAGE 5.
3. When the problem is underway and the training team is active, press RETURN. This will start the data collection process. Note the problem time at which you started the 4051 and record it on the Session Log.

Operating the Problem

1. During the problem, target motion variations may be made via the 21A40 terminals under the direction of the scenario plan or of the training officer.

2. The 4051 data collection process will now operate on its own throughout the problem. If, at any point during the problem, you would like to make note of an event of interest, press button #1, labeled "Event Mark," which is located in the upper left of the keyboard. It is highly recommended that you do this when the training team fires a torpedo, but other events of importance may also be marked.

3. At the conclusion of the problem, press button #10, labeled "End of Data," which is located in the upper left of the keyboard. This signals the 4051 that the problem is over. You will now be asked what you want to do at this point. You can either just stop altogether (quit), immediately collect more data (rerun), or look at the data. Under most circumstances, you should look at the data. Enter the appropriate letter for one of these actions and then press RETURN.

Examining the Data

1. Turn on the hard copy unit that is next to the 4051.

2. Enter the number of the session that you want to examine, and then press RETURN.

3. Enter the sampling rate used in the session, and then press RETURN. For example, you might type 30 SEC. This will be used as a label in the graphs that will be plotted.

4. Select the type of data that you want to see displayed (range, course, or detectability). Enter the appropriate letter and press RETURN.

5. Make a copy of the graphs shown on the 4051 screen by pressing the button labeled MAKE COPY, located in the upper right area of the keyboard.

6. Press RETURN and select the next type of data to be displayed (see step #4 above).

7. Give the paper copies of the graphs to the training officer for use in the critique.

8. When finished, press F followed by RETURN, and then turn off both the hard copy unit and the 4051. If you want to collect data from another problem, press the AUTO LOAD button and continue as before.

APPENDIX F

4051 BASIC PROGRAM FOR DATA DISPLAY

4051 BASIC PROGRAM FOR DATA DISPLAY

```

100 REM*** NSTCPAC STUDY PHASE 1 *****
110 REM----- PROGRAM TO PLOT ENGAGEMENT PROFILE *****
120 INIT
130 REM---READ DATA FROM TAPE
140 PAGE
150 PRINT "ENTER SESSION NUMBER"
160 INPUT F0
170 IF F0<=0 THEN 110
180 FIND 3
190 DIM A0(F0)
200 INPUT @33:A0,A1
210 PRINT "THE NUMBER OF STORED SESSIONS = ";A0(1)
220 PRINT "YOU HAVE ASKED TO SEE NUMBER ";F0
230 PRINT "THE NUMBER OF DATA POINTS FOR THIS SESSION = ";A1
240 PRINT "ENTER TIME BETWEEN SAMPLES"
250 INPUT X$
260 FOR @9=1 TO 1000
270 NEXT @9
280 F1=F0+3
290 FIND F1
300 REM---SELECT DATA TO BE PLOTTED & DISPLAYED
310 PAGE
320 FIND F1
330 DIM R1(A1),R2(A1),D1(A1),D2(A1),N0(A1),P0(A1),T5(10)
340 FOR I=1 TO A1
350 INPUT @33:R1(I),R2(I),D1(I),D2(I),N0(I),P0(I)
360 NEXT I
370 INPUT @33:T5
380 PRINT "WHICH DATA WOULD YOU LIKE TO BE DISPLAYED ?"
390 PRINT "RANGE=R COURSE=C DETECTABILITY=N FINISHED=F"
400 INPUT A$
410 PAGE
420 IF A$="R" THEN 480
430 IF A$="C" THEN 610

```

```

440 IF A$="N" THEN 740
450 IF A$="F" THEN 960
460 PRINT "YOUR REQUEST IS NOT ACKNOWLEDGED, PLEASE TRY AGAIN"
470 GO TO 400
480 REM---RANGE DISPLAY
490 DELETE D1,D2,N0,P0
500 DIM X0(A1),X1(A1),X2(A1)
510 X1=R1
520 X2=R2
530 T$="TARGET RANGE PROFILE FOR SESSION "
540 L$="----TRUE RANGE ...FC RANGE 1 DIVISION = 500 YDS"
550 A6=500
560 GOSUB 980
570 GOSUB 1390
580 INPUT B$
590 DELETE X0,X1,X2
600 GO TO 310
610 REM---COURSE DISPLAY
620 DELETE R1,R2,N0,P0
630 DIM X0(A1),X1(A1),X2(A1)
640 X1=D1
650 X2=D2
660 T$="TARGET COURSE PROFILE FOR SESSION "
670 L$="----TRUE COURSE ...FC COURSE 1 DIVISION = 10 DEGREES"
680 A6=10
690 GOSUB 980
700 GOSUB 1390
710 INPUT B$
720 DELETE X0,X1,X2
730 GO TO 310
740 REM---SIGNAL/NOISE & P(CD) DISPLAY
750 DELETE R1,R2,D1,D2
760 DIM X1(A1)
770 X1=M0
780 Y0=55

```

```

790 Y9=95
800 A6=1
810 G8=00
820 G9=100
830 T$="SIGNAL/NOISE PROFILE FOR SESSION "
840 GOSUB 1800
850 X1=PO
860 Y8=5
870 Y9=45
880 G8=80
890 G9=2
900 T$="PROB OF COUNTERDETECTION PROFILE FOR SESSION "
910 A6=10
920 GOSUB 1800
930 INPUT B$
940 DELETE X1
950 GO TO 310
960 PRINT "FINISHED"
970 END
980 REM ---PLOTTING SUBROUTINE FOR TWO PARAMETERS
990 Y1=100000
1000 Y2=0
1010 FOR I=1 TO A1
1020 Y1=Y1 MIN (X1(I) MIN X2(I))
1030 Y2=Y2 MAX (X1(I) MAX X2(I))
1040 NEXT I
1050 IF A$="R" THEN 1080
1060 Y3=Y1-Y1
1070 GO TO 1130
1080 I9=1
1090 Y3=Y1-I9
1100 IF Y3/500=INT(Y3/500) THEN 1130
1110 I9=I9+1
1120 GO TO 1090
1130 Y4=Y2-Y3

```

```

1140 SCALE 100/A1,40/Y4
1150 VIEWPORT 15,128,52,92
1160 WINDOW 0,A1,Y3,Y2
1170 AXIS 1,A6
1180 MOVE 1,X1(1)
1190 FOR X=2 TO A1
1200 DRAW X,X1(X)
1210 NEXT X
1220 FOR X=1 TO A1
1230 MOVE X,X2(X)
1240 PRINT "#."
1250 NEXT X
1260 GOSUB 2310
1270 VIEWPORT 0,130,0,100
1280 WINDOW 0,130,0,100
1290 MOVE 0,52
1300 PRINT Y3
1310 MOVE 0,92
1320 PRINT Y2
1330 MOVE 80,48
1340 PRINT "TIME INTERVAL = ";X$
1350 HOME
1360 PRINT T$;F0
1370 PRINT L$
1380 RETURN
1390 REM---PLOTTING SUBROUTINE FOR DIFFERENCE VALUES
1400 X0=X2-X1
1410 IF A$(">"C) THEN 1450
1420 FOR I=1 TO A1
1430 IF ABS(X0(I))>180 THEN 2170
1440 NEXT I
1450 Y1=10000
1460 Y2=-10000
1470 FOR I=1 TO A1
1480 Y1=Y1 MIN X0(I)

```

```

1490 Y2=Y2 MAX X0(I)
1500 NEXT I
1510 IF A#="R" THEN 1550
1520 Y3=-180
1530 Y2=180
1540 GO TO 1600
1550 I9=1
1560 Y3=Y1-19
1570 IF Y3/500=INT(Y3/500) THEN 1600
1580 I9=I9+1
1590 GO TO 1560
1600 Y4=Y2-Y3
1610 SCALE 100/A1,40/Y4
1620 VIEWPORT 15,128,0,40
1630 WINDOW 0,A1,Y3,Y2
1640 AXIS 1,A6
1650 MOVE 1,X0(I)
1660 FOR X=2 TO A1
1670 DRAW X,X0(X)
1680 NEXT X
1690 GOSUB 2310
1700 VIEWPORT 0,130,0,100
1710 WINDOW 0,130,0,100
1720 MOVE 0,0
1730 PRINT Y3;
1740 MOVE 0,40
1750 PRINT Y2
1760 MOVE 0,45
1770 PRINT "DIFFERENCE VALUES"
1780 HOME
1790 RETURN
1800 REM---PLOTting SUBROUTINE FOR ONE PARAMETER
1810 Y1=1000
1820 Y2=-1000
1830 FOR I=1 TO A1

```

```

1840 Y1=Y1 MIN X1(I)
1850 Y2=Y2 MAX X1(I)
1860 NEXT I
1870 IF Y9=45 THEN 1930
1880 I9=1
1890 Y3=Y1-I9
1900 IF Y3/10=INT(Y3/10) THEN 1940
1910 I9=I9+1
1920 GO TO 1890
1930 Y3=Y1-Y1
1940 Y4=Y2-Y3
1950 IF Y4=0 THEN 2370
1960 SCALE 100/A1,40/Y4
1970 VIEWPORT 15,128,Y8,Y9
1980 WINDOW 0,A1,Y3,Y2
1990 AXIS 1,A6
2000 MOVE 0,X1(I)
2010 FOR X=1 TO A1
2020 DRAW X,X1(X)
2030 NEXT X
2040 GOSUB 2310
2050 VIEWPORT 0,130,0,100
2060 WINDOW 0,130,0,100
2070 MOVE 5,Y8
2080 PRINT Y3
2090 MOVE 5,Y9
2100 PRINT Y2
2110 MOVE G8,G9
2120 PRINT "TIME INTERVAL = ";X$;
2130 Y7=Y9+5
2140 MOVE 0,Y7
2150 PRINT T$;F0
2160 RETURN
2170 REM---"WRAP AROUND" ROUTINE FOR COURSE
2180 IF D1(I)>180 THEN 2210

```

```
2190 D4=D1(I)
2200 GO TO 2220
2210 D4=360-D1(I)
2220 IF D2(I)=>180 THEN 2250
2230 D5=D2(I)
2240 GO TO 2260
2250 D5=360-D2(I)
2260 D3=D4+D5
2270 IF D3=0 THEN 2290
2280 D3=D3*SGN(X0(I))
2290 X0(I)=D3
2300 GO TO 1440
2310 FOR J=1 TO 10
2320 IF T5(J)=0 THEN 2350
2330 MOVE T5(J),Y3
2340 PRINT "↑";
2350 NEXT J
2360 RETURN
2370 MOVE 0,25
2380 PRINT "PROBABILITY OF COUNTERDETECTION NEVER EXCEEDED ZERO"
2390 GO TO 2130
```

DISTRIBUTION LIST

Assistant Secretary of the Navy (Manpower, Reserve Affairs and Logistics)
Principal Deputy Assistant Secretary of the Navy (Manpower and Reserve Affairs)
Chief of Naval Operations (OP-20), (OP-987H), (OP-964D)
Chief of Naval Personnel (Pers-10c), (Pers-2B)
Chief of Naval Material (NMAT 08T244)
Chief of Naval Research (Code 450) (4)
Chief of Information (OI-2252)
Director of Navy Laboratories
Commandant of the Marine Corps (Code MPI-20)
Chief of Naval Education and Training (N-5), (N-2), (N-232), (N-313)
Chief of Naval Technical Training (Code 016), (Code N-4)
Chief of Naval Education and Training Support
Chief of Naval Education and Training Support (01A)
Commander in Chief, U. S. Atlantic Fleet
Commander in Chief, U. S. Pacific Fleet
Commander, Naval Data Automation Command
Commander, Naval Ocean Systems Center
Commander Submarine Force, U. S. Atlantic Fleet
Commander Submarine Force, U. S. Pacific Fleet
Commander, Submarine Group FIVE
Commander, Naval Training Center, SDIEGO
Commander Third Fleet
Commander Training Command, U. S. Atlantic Fleet (Code N3A)
Commander Training Command, U. S. Pacific Fleet
Commanding Officer, Fleet Anti-Submarine Warfare Training Center, Pacific
Commanding Officer, Fleet Combat Training Center, Pacific (Code 00E)
Commanding Officer, Naval Underwater Systems Center
Commanding Officer, Fleet Combat Training Center, Pacific
Commanding Officer, Fleet Training Center, San Diego
Commanding Officer, Naval Aerospace Medical Institute (Library Code 12) (2)
Commanding Officer, Naval Damage Control Training Center
Commanding Officer, Naval Development and Training Center (Code 0120)
Commanding Officer, Naval Education and Training Information Systems
Activity, Memphis Detachment
Commanding Officer, Naval Education and Training Program Development Center (2)
Commanding Officer, Naval Education and Training Support Center, Pacific
(Code N1B)
Commanding Officer, Naval Submarine Medical Center
Commanding Officer, Naval Submarine School, New London
Commanding Officer, Naval Submarine Training Center, San Diego
Commanding Officer, Naval Training Equipment Center (Technical Library)
Officer in Charge, Naval Education and Training Information Systems
Activity, Memphis Detachment
Director, Training Analysis and Evaluation Group (TAEG)
Secretary Treasurer, U. S. Naval Institute
Science Advisor, ACOS for Tactical Development (COMSECONDFLT)
Superintendent, Naval Academy
Superintendent, Naval Postgraduate School
Army Research Institute for Behavioral and Social Sciences

Human Resources Development Division, U. S. Army Personnel and
Administration Combat Developments Activity
CNET Liaison Office, Air Force Human Resources Laboratory,
Williams Air Force Base
Personnel Research Division, Air Force Human Resources Laboratory (AFSC),
Brooks Air Force Base
Occupational and Manpower Research Division, Air Force Human Resources
Laboratory (AFSC), Brooks Air Force Base
Technical Library, Air Force Human Resources Laboratory (AFSC),
Brooks Air Force Base
Technical Training Division, Air Force Human Resources Laboratory,
Lowry Air Force Base
Flying Training Division, Air Force Human Resources Laboratory,
Williams Air Force Base
Advanced Systems Division, Air Force Human Resources Laboratory,
Wright-Patterson Air Force Base
Program Manager, Life Sciences Directorate, Air Force Office of Scientific
Research (AFSC)
Commander, Armed Forces Vocational Testing Group
Military Assistant for Training and Personnel Technology, Office of the
Under Secretary of Defense for Research and Engineering
Director for Acquisition Planning, OASD (MRA&L)
Director, Defense Activity for Non-Traditional Education Support
Center for Naval Analyses
Coast Guard Headquarters (G-P-1/62)
Library Operations Section, Library of Congress
Defense Documentation Center (12)