

AD-A049 480

ARMY ENGINEER WATERWAYS EXPERIMENT STATION VICKSBURG MISS F/G 13/2
FINITE ELEMENT ANALYSIS OF THE COLUMBIA LOCK PILE FOUNDATION SY--ETC(U)
JUL 74 C S DESAI, L D JOHNSON, C M HARGETT

UNCLASSIFIED

WES-TR-S-74-6

NL

| OF |
AD
A049 480

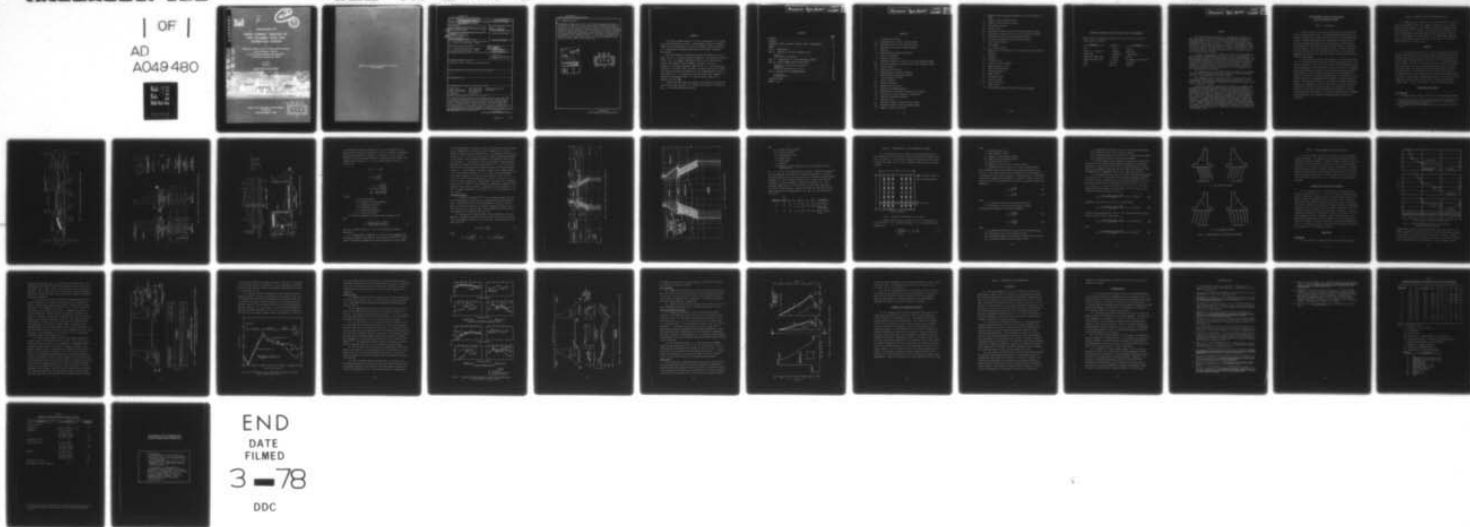

END
DATE
FILMED
3 - 78
DDC

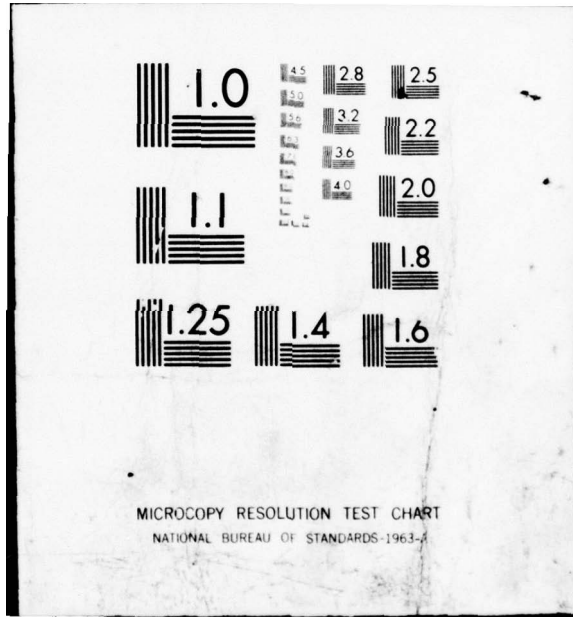

AD A 049480

AD NO. JDC FILE COPY



Q

2



TECHNICAL REPORT S-74-6

FINITE ELEMENT ANALYSIS OF THE COLUMBIA LOCK PILE FOUNDATION SYSTEM

by

Chandrakant S. Desai, Lawrence D. Johnson, Charles M. Hargett
Soils and Pavements Laboratory
U. S. Army Engineer Waterways Experiment Station
P. O. Box 631, Vicksburg, Miss. 39180

July 1974
Final Report

Approved For Public Release; Distribution Unlimited



Prepared for U. S. Army Engineer District, Vicksburg
P. O. Box 60
Vicksburg, Mississippi 39180

DDC
RECEIVED
FEB 6 1978
D

**Destroy this report when no longer needed. Do not return
it to the originator.**

Unclassified

SECURITY CLASSIFICATION OF THIS PAGE (When Data Entered)

REPORT DOCUMENTATION PAGE		READ INSTRUCTIONS BEFORE COMPLETING FORM													
1. REPORT NUMBER Technical Report S-74-6	14 WES-TR-S-74-6	GOVT ACCESSION NO.	3. RECIPIENT'S CATALOG NUMBER												
4. TITLE (and Subtitle)	FINITE ELEMENT ANALYSIS OF THE COLUMBIA LOCK FILE FOUNDATION SYSTEM.		5. TYPE OF REPORT & PERIOD COVERED Final report.												
7. AUTHOR(s)	Chandrakant S./Desai, Lawrence D./Johnson Charles M./Hargett		6. PERFORMING ORG. REPORT NUMBER												
9. PERFORMING ORGANIZATION NAME AND ADDRESS	U. S. Army Engineer Waterways Experiment Station P. O. Box 631, Vicksburg, Miss. 39180		8. CONTRACT OR GRANT NUMBER(s)												
11. CONTROLLING OFFICE NAME AND ADDRESS	U. S. Army Engineer District, Vicksburg P. O. Box 60, Vicksburg, Miss. 39180		10. PROGRAM ELEMENT, PROJECT, TASK AREA & WORK UNIT NUMBERS												
14. MONITORING AGENCY NAME & ADDRESS (if different from Controlling Office)			12. REPORT DATE 11 July 1974												
			13. NUMBER OF PAGES 38 (12) 42 P.												
			15. SECURITY CLASS. (of this report) Unclassified												
16. DISTRIBUTION STATEMENT (of this Report) Approved for public release; distribution unlimited.															
17. DISTRIBUTION STATEMENT (of the abstract entered in Block 20, if different from Report) Columbia Lock (on the Ouachita River near Columbia, Louisiana)															
18. SUPPLEMENTARY NOTES															
19. KEY WORDS (Continue on reverse side if necessary and identify by block number)															
<table border="0"> <tr> <td>Columbia Lock</td> <td>Load distribution</td> <td>Settlement (structural)</td> </tr> <tr> <td>Computer applications</td> <td>Locks (Waterways)</td> <td>U-frame locks</td> </tr> <tr> <td>Finite element method</td> <td>File foundations</td> <td></td> </tr> <tr> <td>Foundations</td> <td>File groups</td> <td></td> </tr> </table>				Columbia Lock	Load distribution	Settlement (structural)	Computer applications	Locks (Waterways)	U-frame locks	Finite element method	File foundations		Foundations	File groups	
Columbia Lock	Load distribution	Settlement (structural)													
Computer applications	Locks (Waterways)	U-frame locks													
Finite element method	File foundations														
Foundations	File groups														
20. ABSTRACT (Continue on reverse side if necessary and identify by block number)															
<p>The Columbia Lock was designed as a gravity-type structure in which the load is transferred essentially through the foundation piles. Results obtained using Hrennikoff's method did not agree closely with observed field data in terms of the distribution of loads in the piles. The finite element (FE) method was therefore used to predict the behavior of the lock structure. As an approximation and to avoid undue amounts of manpower and computer efforts, the three-dimensional system was idealized as a structurally equivalent</p>															

DD FORM 1 JAN 73 1473 EDITION OF 1 NOV 65 IS OBSOLETE

Unclassified

SECURITY CLASSIFICATION OF THIS PAGE (When Data Entered)

038 100 JOB

center
p 14733

Unclassified

SECURITY CLASSIFICATION OF THIS PAGE(When Data Entered)

20. ABSTRACT (Continued)

two-dimensional plane strain system. The FE method simulated major steps of construction including the in situ stress condition, dewatering, excavation, construction of piles and lock, backfilling, filling the lock with water, and development of uplift pressures. Nonlinear behavior of soils and of interfaces between the lock and surrounding soils and between the piles and the foundation soils was introduced into the analysis. The distribution of load in piles in the FE analysis showed improved agreement with field data in comparison with the agreement shown by Hrennikoff's method. The FE computations verified the trend shown by the observed field data that the piles on the backfill side carried an increased share of the applied load.

ACCESSION TO	
RTIS	White Section <input checked="" type="checkbox"/>
DDC	Buff Section <input type="checkbox"/>
UNANNOUNCED	<input type="checkbox"/>
JUSTIFICATION	
BY	
DISTRIBUTION/AVAILABILITY CODES	
Dist.	AVAIL. and/or SPECIAL
A	

DDC
RECEIVED
FEB 6 1978
D

Unclassified

SECURITY CLASSIFICATION OF THIS PAGE(When Data Entered)

FOREWORD

The finite element analysis of the pile foundations of the Columbia Lock was sponsored by the U. S. Army Engineer District, Vicksburg (VED), and was conducted by the Soils and Pavements Laboratory (S&PL), U. S. Army Engineer Waterways Experiment Station (WES), Vicksburg, Mississippi.

The investigations described herein were performed by Dr. C. S. Desai and Dr. L. D. Johnson, Research Engineers, Soil Mechanics Division (SMD). Mr. C. M. Hargett, Engineering Division, VED, monitored the project and provided valuable comments and advice. Mr. W. C. Sherman, Jr., Research Consultant, SMD, and Mr. S. J. Johnson, Special Assistant to the Chief, S&PL, provided a technical review of the report. The report was reviewed and approved by the Vicksburg District prior to publication. Mr. V. M. Agostinelli, VED, provided useful comments. During the investigation, Mr. J. P. Sale was Chief, S&PL; Mr. C. L. McAnear was Chief, SMD.

Directors of WES during the analysis and preparation and publication of this report were BG E. D. Peixotto, CE, and COL G. H. Hilt, CE. Mr. F. R. Brown was Technical Director.

Preceding Page BLANK - NOT FILMED

CONTENTS

	<u>Page</u>
FOREWORD.	iii
NOTATION.	vii
CONVERSION FACTORS, BRITISH TO METRIC UNITS OF MEASUREMENT.	ix
SUMMARY	xi
PART I: INTRODUCTION	1
PART II: DETAILS OF LOCK AND FOUNDATION SOILS.	2
Subsoils.	2
Stress-Strain Parameters.	2
PART III: IDEALIZATION AS A TWO-DIMENSIONAL PROBLEM.	11
PART IV: FINITE ELEMENT ANALYSIS AND RESULTS	15
Simulation of Construction Sequences.	15
Comparisons	15
Comments on Formulation and Codes	25
PART V: CONCLUSIONS AND RECOMMENDATIONS.	26
Conclusions	26
Recommendations	27
LITERATURE CITED.	28
TABLES 1 and 2	

NOTATION

A	Projected area of pile
A_{ei}	Equivalent area of piles battered inward
A_{eo}	Equivalent area of piles battered outward
c	Mohr-Coulomb cohesive strength parameter
c_a	Adhesion
d	Experimentally determined parameter
D	Depth of overburden
E	Modulus of elasticity
E_{ei}	Equivalent modulus of elasticity for piles battered inward
E_{eo}	Equivalent modulus of elasticity for piles battered outward
E_i	Initial modulus
E_t	Tangent elastic modulus
F	Experimentally determined parameter
G	Experimentally determined parameter
k_i	Initial tangent stiffness
k_n	Normal stiffness
k_r	Residual stiffness
k_{st}	Tangent shear stiffness
K	Hyperbolic loading parameter
K_j	Experimentally determined parameter for interface
K_o^c	Coefficient of earth pressure in compression
K_u	Hyperbolic unloading parameter
L	Length of piles
L_{ei}	Equivalent length of piles battered inward
L_{eo}	Equivalent length of piles battered outward
m	Number of rows in a monolith

n	Experimentally determined parameter; also, total number of piles
n_i	Number of piles battered inward
n_o	Number of piles battered outward
p_a	Atmospheric pressure
R_f	Failure ratio
s_{ei}	Equivalent stiffness per strip for piles battered inward
s_{eo}	Equivalent stiffness per strip for piles battered outward
s_i	Stiffness per strip for piles battered inward
s_o	Stiffness per strip for piles battered outward
S	Total axial stiffness
γ	Unit weight
γ_w	Unit weight of water
δ	Angle of friction between lock or pile material and surrounding soils
λ_1	Parameter
λ_2	Parameter
ν	Poisson's ratio
ν_f	Poisson's ratio at failure
ν_t	Tangent Poisson's ratio
σ_1	Major principal stress
σ_3	Confining pressure
σ_n	Normal stress
σ_x	Horizontal stress
σ_y	Vertical stress
$\sigma_1 - \sigma_3$	Stress difference
τ	Shear stress
ϕ	Mohr-Coulomb (angle of internal friction) parameter

CONVERSION FACTORS, BRITISH TO METRIC UNITS OF MEASUREMENT

British units of measurement used in this report can be converted to metric units as follows:

<u>Multiply</u>	<u>By</u>	<u>To Obtain</u>
feet	0.3048	meters
miles (U. S. statute)	1.609344	kilometers
square feet	0.09290304	square meters
pounds per square foot	47.88026	pascals
pounds per cubic foot	16.01846	kilograms per cubic meter
tons	907.1847	kilograms
kip	4448.222	newtons

SUMMARY

The Columbia Lock was designed as a gravity-type structure in which the load is transferred essentially through the foundation piles. Field performance of the lock pile system was measured in terms of settlements and loads in the piles. The structure was analyzed using Hrennikoff's method, which is based on a number of simplifying assumptions such as linear material behavior and linear distribution of loads in the pile groups. The observations in terms of distribution of loads in the piles did not show good correlation with the distribution predicted by Hrennikoff's method.

In order to evolve a more rational procedure for design analysis and for improved understanding of behavior of the pile foundations, it was proposed to analyze the system using the finite element method. The method simulated major steps of the construction sequence including in situ stresses, dewatering, excavation, construction of piles and lock, backfilling, filling the lock with water, and development of uplift pressures. Nonlinear behavior of soils and of interfaces between the lock and surrounding soils and between piles and the foundation soils was introduced into the analysis.

For simplicity and to avoid undue amounts of manpower and computer efforts, the three-dimensional system was idealized as a structurally equivalent two-dimensional plane strain system.

The numerical results in terms of loads in the piles and settlements showed satisfactory correlation with the observations. It is believed that the approximate two-dimensional analysis can provide solutions of practical accuracy.

An available computer code which was developed for U-frame locks was modified to handle the gravity-type structures, particularly the foundation piles and interfaces. Although the results were found to be satisfactory, it seems that the code will need further modifications. This will involve proper introduction of interfaces and their properties and a scheme that can avoid excessive deformations of "air" elements that need to be introduced during various excavation and construction sequences. It appears that the existence of air elements renders the total stiffness matrix ill-conditioned and hence the excessive deformations. It may be possible to introduce a scheme such that the need for air elements is avoided in most computations. Moreover, the work can be continued further to analyze the interaction effects and the behavior of the structure itself.

FINITE ELEMENT ANALYSIS OF THE COLUMBIA
LOCK PILE FOUNDATION SYSTEM

PART I: INTRODUCTION

1. Many lock walls are designed as gravity-type structures supported on battered pile groups. A system incorporating piles with alternate rows battered in opposite directions poses a three-dimensional problem. Although three-dimensional formulations and codes based on the finite element (FE) method are possible, their use for the lock pile foundation problem would involve formidable amounts of human and computer efforts. The three-dimensional problem is therefore replaced by a structurally equivalent two-dimensional system. To the authors' knowledge, a problem of this type has not been solved previously using a numerical (FE) method.

2. The Columbia Lock walls were designed as a gravity-type structure.^{1,2} Hrennikoff's method³ was used for design analysis and to evaluate distribution of loads in the pile groups. Field observations during and subsequent to the construction of the lock were not in agreement with the distribution of loads in the pile groups predicted by Hrennikoff's method. It was, therefore, proposed to use the FE method to simulate as closely as possible various sequences of construction and to predict histories of settlements and distribution of loads in the pile groups. The sequences simulated in the analysis included dewatering, excavation, installation of piles, construction of the piles and lock, backfilling, filling the lock with water, and development of uplift pressures. These sequences were preceded by computation of in situ stresses under gravity loading. The numerical predictions are compared with observations, and conclusions regarding design analysis are presented.

PART II: DETAILS OF LOCK AND FOUNDATION SOILS

3. Columbia Lock is located in a cutoff between miles 131.5* and 134.5 on the Ouachita River near Columbia, Louisiana. Fig. 1 shows a typical section through the lock chamber together with foundation and surrounding soils.^{2,4,5} Details of two monoliths, 10-L and 11-R, that were instrumented and are considered in the FE analysis are shown in fig. 2. This figure also shows details of the strain gages installed on the steel H-piles. A plan of the lock and details of the instrumented monoliths are shown in fig. 3.

Subsoils

4. The subsoils beneath the lock consist essentially of cohesive backswamp deposits and/or cohesionless substratum deposits beneath the east wall and Tertiary deposits interfingering with colluvium and substratum deposits beneath the west wall, fig. 1.^{4,6,7} The backswamp deposits consist of stiff to very stiff fat clays and very soft to medium silty clays and silty sands. Substratum deposits consist of dense to very dense sands. The Tertiary soils can be divided into two parts. The upper part, to el -20.00,** consists of dense, gray, massive to poorly bedded silts, silty sands, and fine sands with scattered horizontal layers of stiff, gray, and grayish-brown clay. The lower portion is composed of thicker zones of stiff, gray to brown clay mixed with thinner layers of dense to very dense, gray, fine, and silty sands.

Stress-Strain Parameters

Soil behavior

5. Results from a number of triaxial tests performed previously

* A table of factors for converting British units of measurement to metric units is presented on page ix.

** All elevations (el) cited herein are in feet referred to mean sea level.

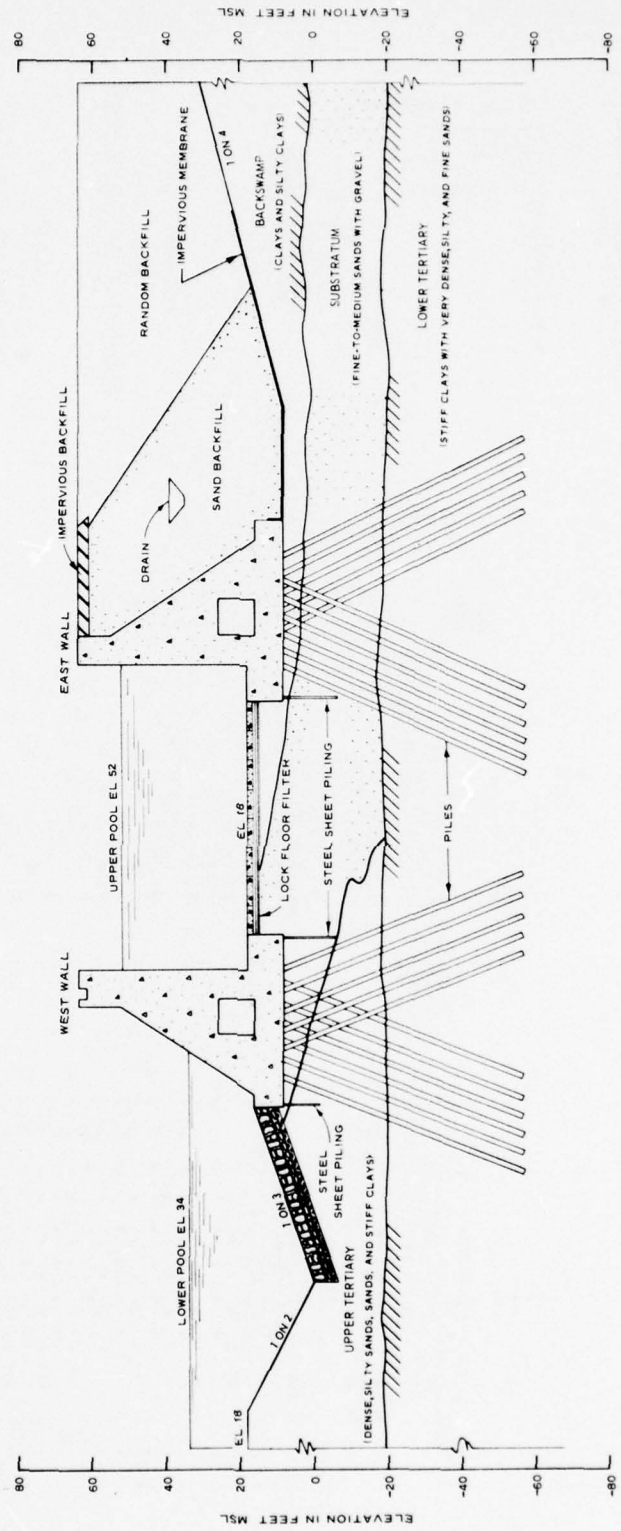

Fig. 1. Cross section and soil profile, Columbia Lock

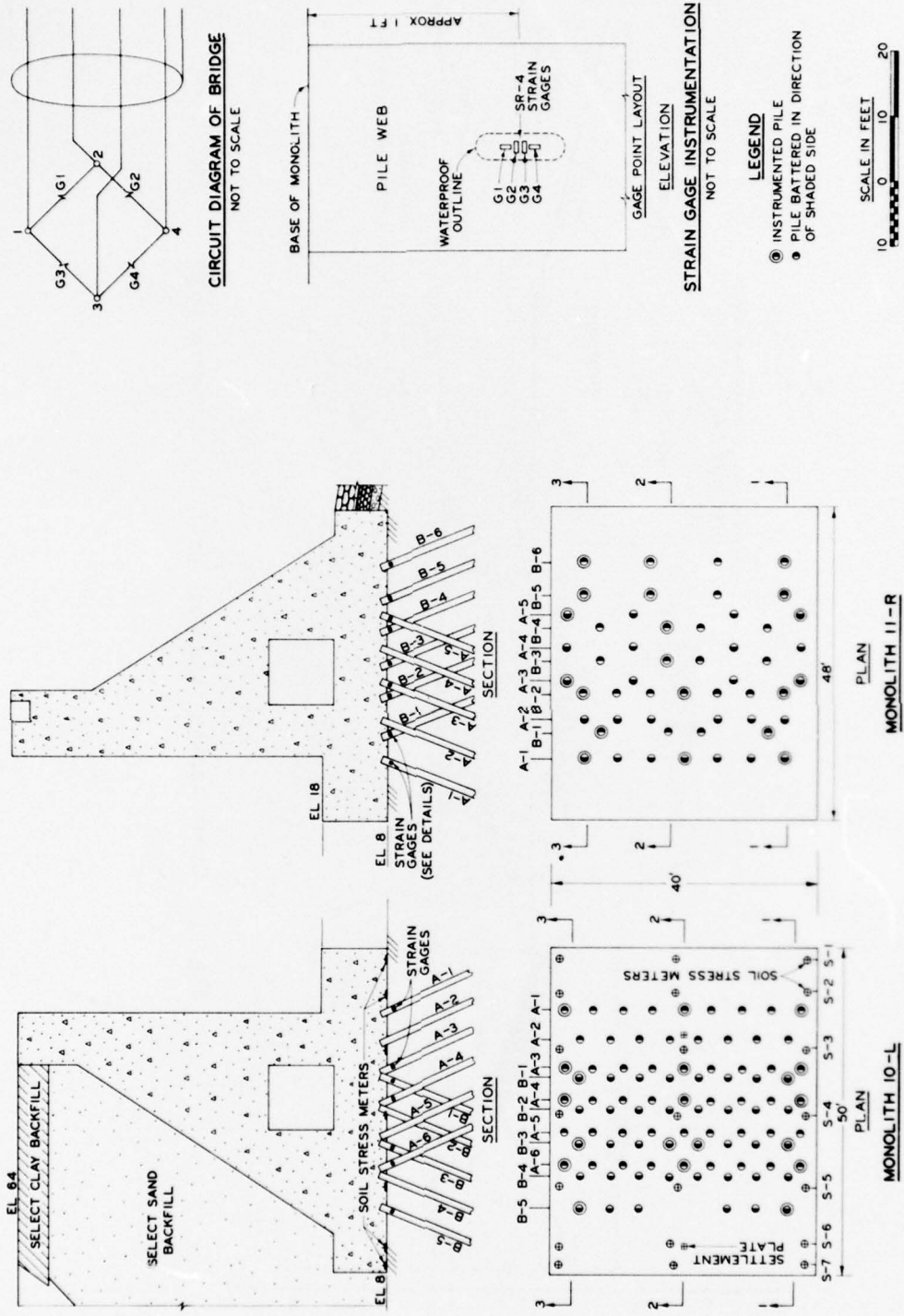
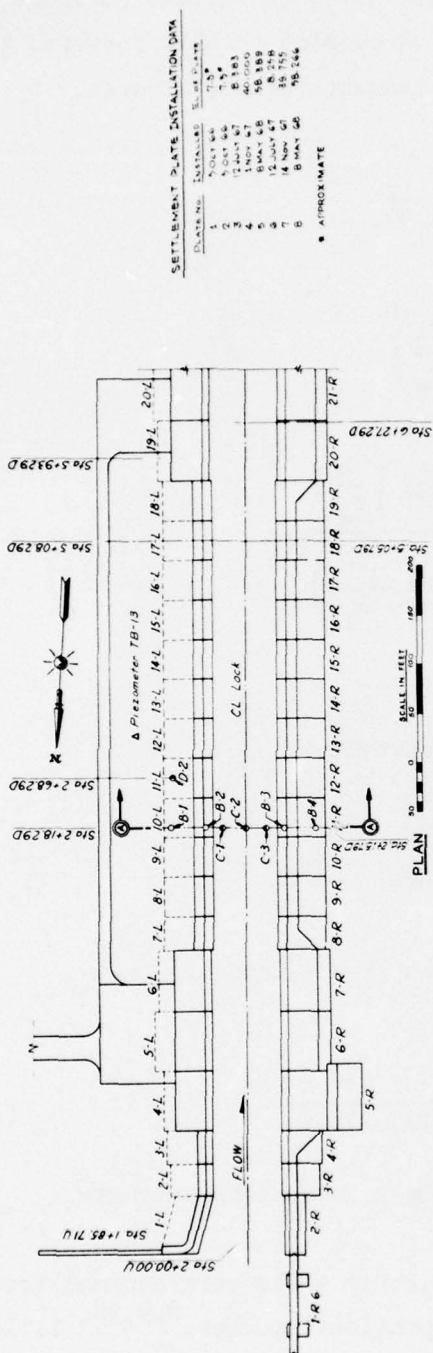

Fig. 2. Details of monoliths and pile instrumentation



SETTLEMENT PLATE INSTALLATION DATA

DATE	NO.	INSTALLER	TYPE OF PLATE
1	1	10 OCT 44	T-1
2	2	12 MAY 47	T-2
3	3	12 MAY 47	MC-1
4	4	12 MAY 47	MC-2
5	5	12 MAY 47	MC-3
6	6	12 MAY 47	MC-4
7	7	12 MAY 47	MC-5
8	8	12 MAY 47	MC-6
9	9	12 MAY 47	MC-7
10	10	12 MAY 47	MC-8
11	11	12 MAY 47	MC-9
12	12	12 MAY 47	MC-10
13	13	12 MAY 47	MC-11
14	14	12 MAY 47	MC-12
15	15	12 MAY 47	MC-13
16	16	12 MAY 47	MC-14
17	17	12 MAY 47	MC-15
18	18	12 MAY 47	MC-16
19	19	12 MAY 47	MC-17
20	20	12 MAY 47	MC-18
21	21	12 MAY 47	MC-19
22	22	12 MAY 47	MC-20
23	23	12 MAY 47	MC-21
24	24	12 MAY 47	MC-22
25	25	12 MAY 47	MC-23
26	26	12 MAY 47	MC-24
27	27	12 MAY 47	MC-25
28	28	12 MAY 47	MC-26
29	29	12 MAY 47	MC-27
30	30	12 MAY 47	MC-28
31	31	12 MAY 47	MC-29
32	32	12 MAY 47	MC-30
33	33	12 MAY 47	MC-31
34	34	12 MAY 47	MC-32
35	35	12 MAY 47	MC-33
36	36	12 MAY 47	MC-34
37	37	12 MAY 47	MC-35
38	38	12 MAY 47	MC-36
39	39	12 MAY 47	MC-37
40	40	12 MAY 47	MC-38
41	41	12 MAY 47	MC-39
42	42	12 MAY 47	MC-40
43	43	12 MAY 47	MC-41
44	44	12 MAY 47	MC-42
45	45	12 MAY 47	MC-43
46	46	12 MAY 47	MC-44
47	47	12 MAY 47	MC-45
48	48	12 MAY 47	MC-46
49	49	12 MAY 47	MC-47
50	50	12 MAY 47	MC-48
51	51	12 MAY 47	MC-49
52	52	12 MAY 47	MC-50
53	53	12 MAY 47	MC-51
54	54	12 MAY 47	MC-52
55	55	12 MAY 47	MC-53
56	56	12 MAY 47	MC-54
57	57	12 MAY 47	MC-55
58	58	12 MAY 47	MC-56
59	59	12 MAY 47	MC-57
60	60	12 MAY 47	MC-58
61	61	12 MAY 47	MC-59
62	62	12 MAY 47	MC-60
63	63	12 MAY 47	MC-61
64	64	12 MAY 47	MC-62
65	65	12 MAY 47	MC-63
66	66	12 MAY 47	MC-64
67	67	12 MAY 47	MC-65
68	68	12 MAY 47	MC-66
69	69	12 MAY 47	MC-67
70	70	12 MAY 47	MC-68
71	71	12 MAY 47	MC-69
72	72	12 MAY 47	MC-70
73	73	12 MAY 47	MC-71
74	74	12 MAY 47	MC-72
75	75	12 MAY 47	MC-73
76	76	12 MAY 47	MC-74
77	77	12 MAY 47	MC-75
78	78	12 MAY 47	MC-76
79	79	12 MAY 47	MC-77
80	80	12 MAY 47	MC-78
81	81	12 MAY 47	MC-79
82	82	12 MAY 47	MC-80
83	83	12 MAY 47	MC-81
84	84	12 MAY 47	MC-82
85	85	12 MAY 47	MC-83
86	86	12 MAY 47	MC-84
87	87	12 MAY 47	MC-85
88	88	12 MAY 47	MC-86
89	89	12 MAY 47	MC-87
90	90	12 MAY 47	MC-88
91	91	12 MAY 47	MC-89
92	92	12 MAY 47	MC-90
93	93	12 MAY 47	MC-91
94	94	12 MAY 47	MC-92
95	95	12 MAY 47	MC-93
96	96	12 MAY 47	MC-94
97	97	12 MAY 47	MC-95
98	98	12 MAY 47	MC-96
99	99	12 MAY 47	MC-97
100	100	12 MAY 47	MC-98
101	101	12 MAY 47	MC-99
102	102	12 MAY 47	MC-100

* APPROXIMATE

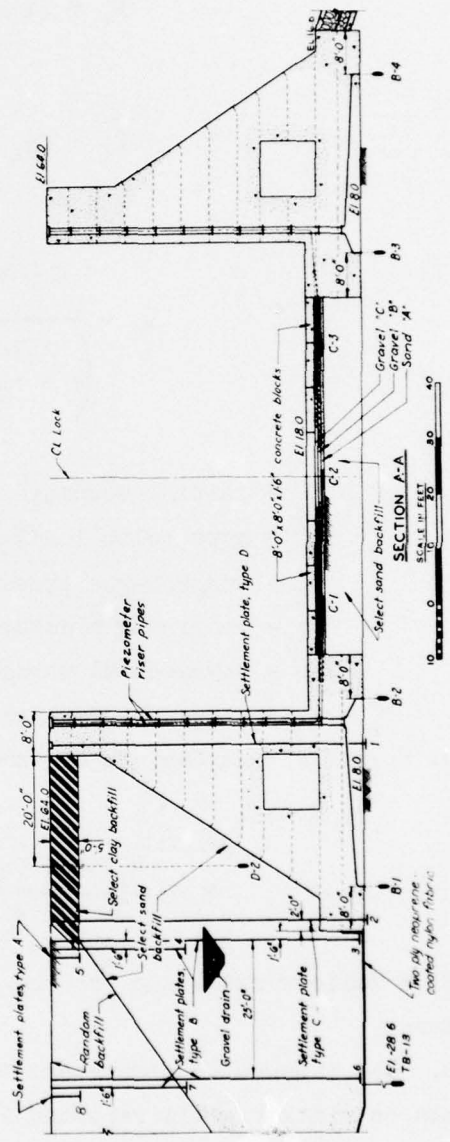

Fig. 3. Details of instrumented monoliths

on the Tertiary clays were available.^{1,2} For the FE analysis, the stress-strain curves were simulated by using the hyperbolic formulation. Details of the hyperbolic formulation are given in various publications⁸⁻¹⁵ and are not repeated herein. According to this concept, the tangent elastic modulus, E_t , and the tangent Poisson's ratio, ν_t , are given by

$$E_t = (1 - \lambda_1)^2 E_i \quad (1)$$

$$E_i = K p_a \left(\frac{\sigma_3}{p_a} \right)^n$$

$$\nu_t = \frac{G - F \log \left(\frac{\sigma_3}{p_a} \right)}{\left(1 - \frac{(\sigma_1 - \sigma_3)d}{E_i(1 - \lambda_1)} \right)^2} \quad (2)$$

in which

E_i = initial modulus

K = hyperbolic loading parameter

p_a = atmospheric pressure

σ_3 = confining pressure

n = exponential parameter

$\sigma_1 - \sigma_3$ = stress difference

$G, F,$ and d = parameters determined from laboratory tests

and

$$\lambda_1 = \frac{R_f(\sigma_1 - \sigma_3)(1 - \sin \phi)}{2c \cos \phi + 2\sigma_3 \sin \phi} \quad (3)$$

Here R_f = failure ratio and c and ϕ = Mohr-Coulomb strength parameters.

6. The hyperbolic parameters for other soils were adopted from test data on similar soils reported in previous studies.^{8,9,15} Table 1 shows the hyperbolic parameters and other properties of soils adopted

for the FE analysis. The values of K_O^C , the coefficient of earth pressure in compression, for clay soils were estimated on the basis of values for similar overconsolidated soils. The question of field evaluations of K_O^C is wider in scope and will require considerable research in the future. Since adequate information on volumetric behavior was not available, ν , the Poisson's ratio, was assumed to remain constant. Moreover, the analysis does not permit values of $\nu \geq 0.5$, and it is believed that the gross predicted behavior may not be affected significantly if ν were treated as variable. Values of the Young's modulus E for concrete were computed as 4×10^8 lb/ft², and the equivalent E for piles in monoliths 11-R and 10-L was computed as 6.8×10^7 and 11.8×10^7 lb/ft² for piles battered out, and 7.5×10^7 and 13.3×10^7 lb/ft² for piles battered in, respectively. The densities of equivalent piles (6 and 7 in table 1) were computed by equating the weights of the equivalent piles and the H-piles. Computation of the equivalent E for piles is given subsequently. The value of E for air elements was set at 10 lb/ft².

Interface behavior

7. Interface elements^{8,9,11,13} were introduced between the lock and surrounding soils and between the equivalent piles and foundation soils. The FE mesh for the lock and foundation is shown in fig. 4; part of the mesh with details of interface elements is shown in fig. 5. Details of the soil layers in fig. 4 were obtained from boring logs in the neighborhood of monoliths 10-L and 11-R.

8. The nonlinear interface behavior was simulated by using the hyperbolic parameters adopted from direct shear test results for similar soils (sands and clays) with pile material (concrete and steel) at other sites.^{9,11}

$$k_{st} = (1 - \lambda_2)^2 k_i \quad (4)$$

where

$$k_i = K_j \gamma_w \left(\frac{\sigma_n}{p_a} \right)^n \quad \text{and} \quad \lambda_2 = \frac{R_f \tau}{c_a + \sigma_n \tan \delta}$$

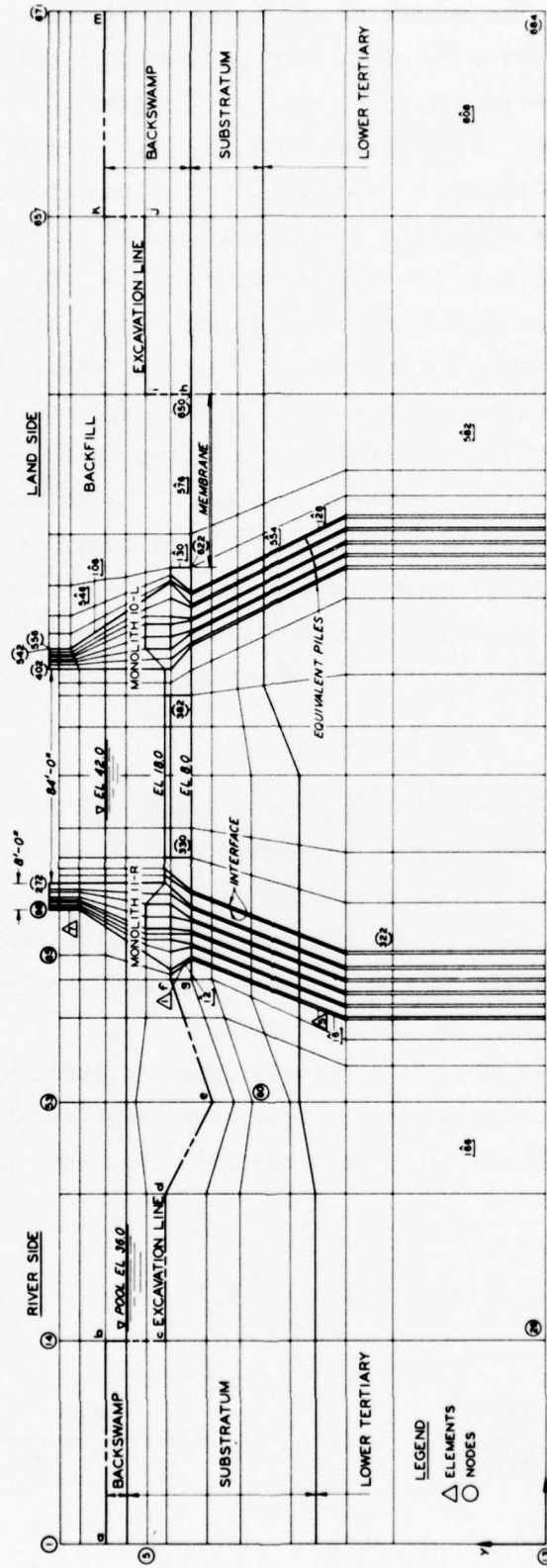

Fig. 4. Finite element mesh for lock and foundations

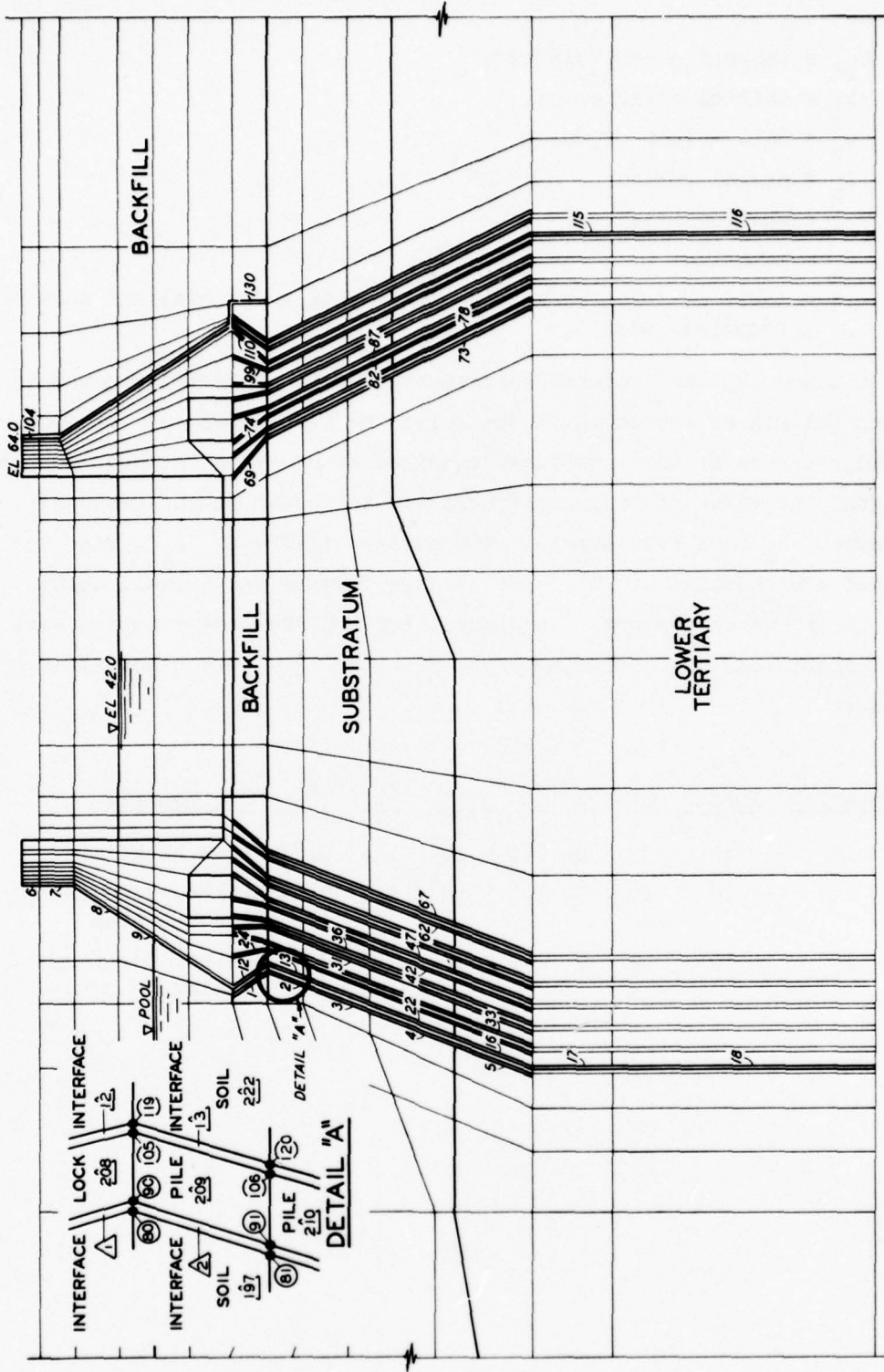

Fig. 5. Details of piles and interfaces

and

k_{st} = tangent shear stiffness

k_i = initial stiffness

γ_w = unit weight of water

σ_n = normal stress

τ = shear stress

c_a = adhesion

δ = angle of friction between lock or pile material and surrounding soils

K_j , n , and R_f are determined from test data. Hyperbolic parameters for the interfaces are shown in the following tabulation. As soon as the shear stress at the interfaces equalled or exceeded the Mohr-Coulomb strength, the value of shear stiffness was set equal to the residual stiffness, k_r (see tabulation). The normal stiffness, k_n , was assigned a high value of 10^8 lb/ft³ before failure and a small value of 10 lb/ft³ after failure. Interfaces between the same material were kept inoperational by assigning both k_{st} and k_n very high values of 10^8 lb/ft³.

<u>Material</u>	<u>k_r lb/ft³</u>	<u>δ</u>	<u>c_a</u>	<u>K_j</u>	<u>n</u>	<u>R_f</u>	<u>Remarks</u>
12	10	33	0	7.5×10^4	1.0	0.87	Lock backfill
13	10	26	0	2.5×10^4	1.0	0.87	Piles, sand substratum
14	10	20	0	2.5×10^4	1.0	0.87	Piles, Tertiary clay

PART III: IDEALIZATION AS A TWO-DIMENSIONAL PROBLEM

9. The three-dimensional Columbia lock pile foundation system was idealized as a two-dimensional plane strain problem by making a number of assumptions. Fig. 6 shows a schematic representation of a monolith with two types of piles, those battered inward and those battered outward.

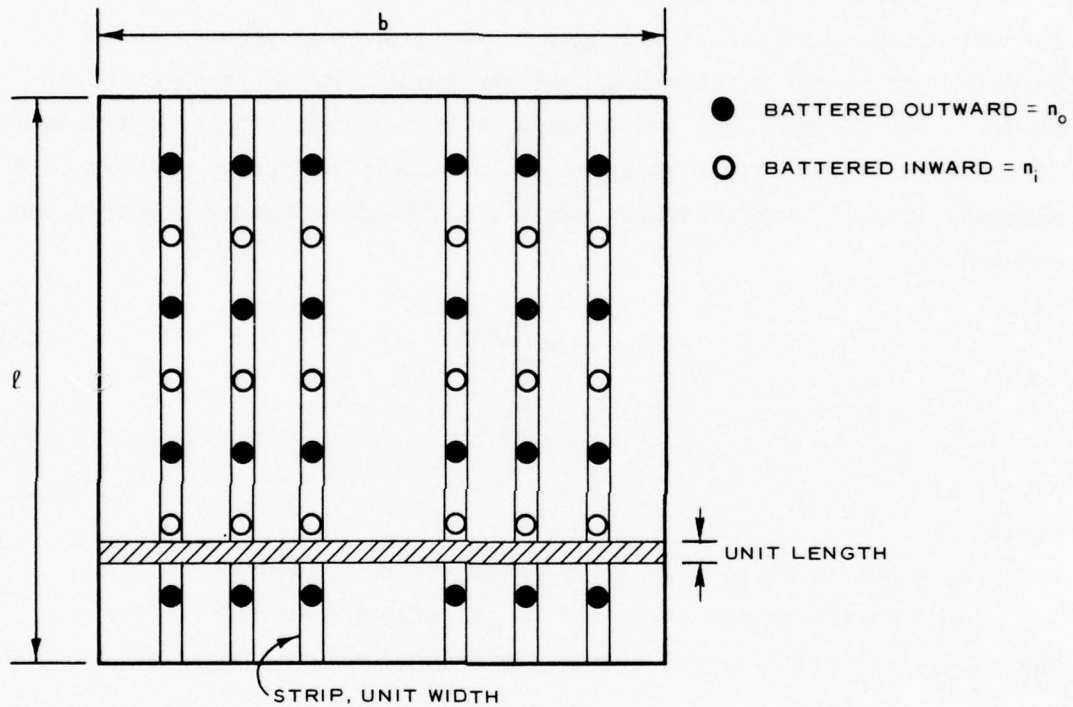

Fig. 6. Schematic representation of monolith

10. Assume that the major response of piles is provided by the axial stiffness. The total axial stiffness, S , of a monolith can be expressed as

$$S = \sum_{j=1}^n \frac{A_j E_j}{L_j} = (n_i + n_o) \frac{AE}{L} \quad (5)$$

where

A = projected area of pile

n = total number of piles

n_i = number of piles battered inward

n_o = number of piles battered outward

A = projected area of pile

E = modulus of elasticity for the steel H-piles

L = length of pile (all piles are of equal length and area)

For the analysis herein, the length of the piles was assumed to be 70.0 ft. It is noted, however, that the magnitudes of the length can be different if the piles are assumed to be point-bearing or frictional. If the total stiffness is assigned to m number of strips or rows in a monolith, fig. 6, the stiffness per strip for piles battered inward and outward is

$$s_i = \frac{n_i AE}{m L} \quad (6a)$$

$$s_o = \frac{n_o AE}{m L} \quad (6b)$$

where

s_i = stiffness per strip for piles battered inward

s_o = stiffness per strip for piles battered outward

The equivalent stiffness of a strip is defined as

$$s_{ei} = \frac{A_{ei} E_{ei}}{L_{ei}} \quad (7a)$$

$$s_{eo} = \frac{A_{eo} E_{eo}}{L_{eo}} \quad (7b)$$

where

s_{ei} = equivalent stiffness per strip for piles battered inward

A_{ei} = equivalent area of piles battered inward

E_{ei} = equivalent modulus of elasticity for piles battered inward

L_{ei} = equivalent length of piles battered inward

s_{eo} = equivalent stiffness per strip for piles battered outward
 A_{eo} = equivalent area of piles battered outward
 E_{eo} = equivalent modulus of elasticity for piles battered outward
 L_{eo} = equivalent length of piles battered outward

11. Two FE analyses were performed, one with piles battered outward and one with piles battered inward; and properties of each were evaluated. In both cases a unit width of strip was chosen for convenience, and equivalent properties for unit length were evaluated. The following are the computations for the two cases, fig. 7a and b.

12. The cross-sectional area of the H-pile used in the foundation was 0.149 sq ft.^{1,2} In the case of piles battered inward, there were six rows of piles in monolith 10-L and five rows in monolith 11-R. For monolith 10-L piles with inward batter, shown in fig. 7a, $n_i = 53$, $A = 0.149$ sq ft, $E = 4.04 \times 10^9$ lb/ft², $m = 6$, $A_{ei} = 1 \times 40$ (unit width multiplied by length of the monolith) = 40 sq ft, and $L = L_{ei}$. Therefore, equating equations 6a and 7a,

$$E_{ei} = \frac{53 \times 0.149 \times 4.04 \times 10^9}{6 \times 40} = 1.33 \times 10^8 \text{ lb/ft}^2 \quad (8a)$$

Similarly, for monolith 11-R piles with inward batter

$$E_{ei} = \frac{25 \times 0.149 \times 4.04 \times 10^9}{5 \times 40} = 7.5 \times 10^7 \text{ lb/ft}^2 \quad (8b)$$

For piles with outward batter, fig. 7b, the equivalent moduli for monoliths 10-L and 11-R are, respectively:

$$E_{eo} = \frac{38 \times 0.149 \times 4.04 \times 10^9}{5 \times 40} = 1.18 \times 10^8 \text{ lb/ft}^2 \quad (9a)$$

and

$$E_{eo} = \frac{27 \times 0.149 \times 4.04 \times 10^9}{6 \times 40} = 6.8 \times 10^7 \text{ lb/ft}^2 \quad (9b)$$

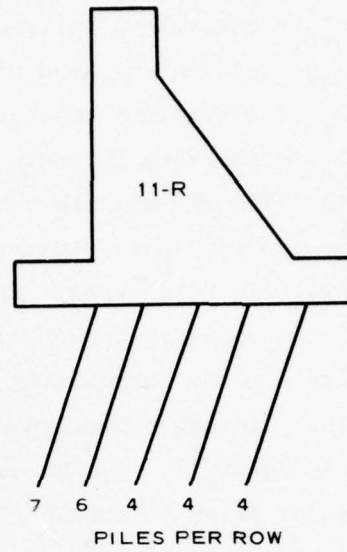
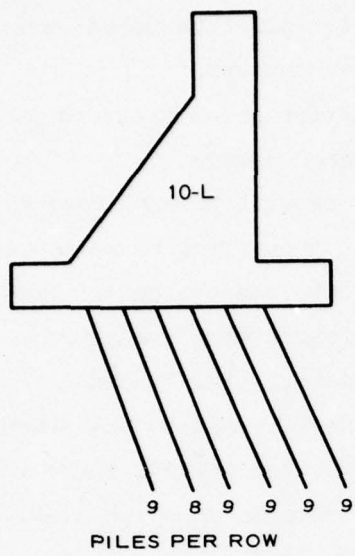

a. Piles battered inward

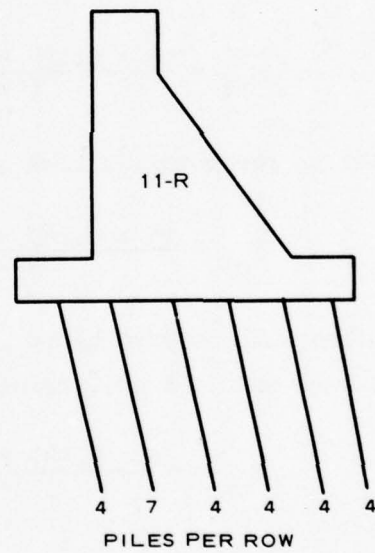
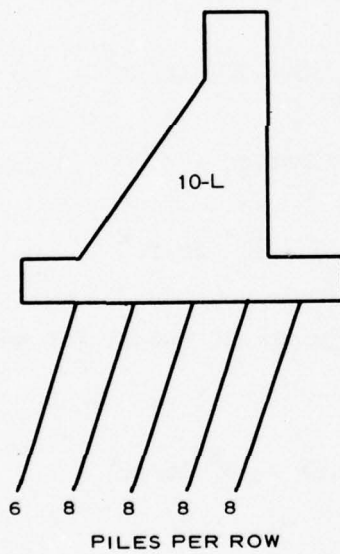

b. Piles battered outward

Fig. 7. Representation for equivalent properties

PART IV: FINITE ELEMENT ANALYSIS AND RESULTS

13. Finite element analyses of U-frame locks were performed by Clough and Duncan.⁸ The computer code developed previously⁸ was utilized for the present analysis. However, a number of modifications and corrections were introduced. The stresses in the interface elements were made to be consistent with those in the surrounding soil elements. Modifications were made to introduce interfaces and piles in the foundation such that proper interfaces became operational as soon as the buildup sequence was initiated. Similar changes were made for interfaces that became operational as the structural buildup and backfill proceeded.

Simulation of Construction Sequences

14. The steps or cases in the simulation of construction sequences are shown in table 2. A cycle of the finite element procedure was first performed to compute initial in situ stresses caused by the gravity loading. Dewatering was then simulated to lower the water table, which was followed by excavation in three steps. The materials of elements occupying the locations of battered piles were subsequently changed from soil to steel piles with equivalent properties. The lock structure was then constructed in three steps. Sequences 11 and 12 simulated, respectively, the buildup of water in the lock up to el 42.0 and development of uplift pressures. Uplift pressures equal to the hydrostatic pressure due to the waterhead in the lock were applied at nodes at the bases of monoliths 10-L and 11-R and at the membrane (see fig. 4). For each cycle, three iterations were performed and found to be satisfactory for a convergent solution.

Comparisons

Settlements

15. Fig. 8 shows a comparison between the predicted vertical

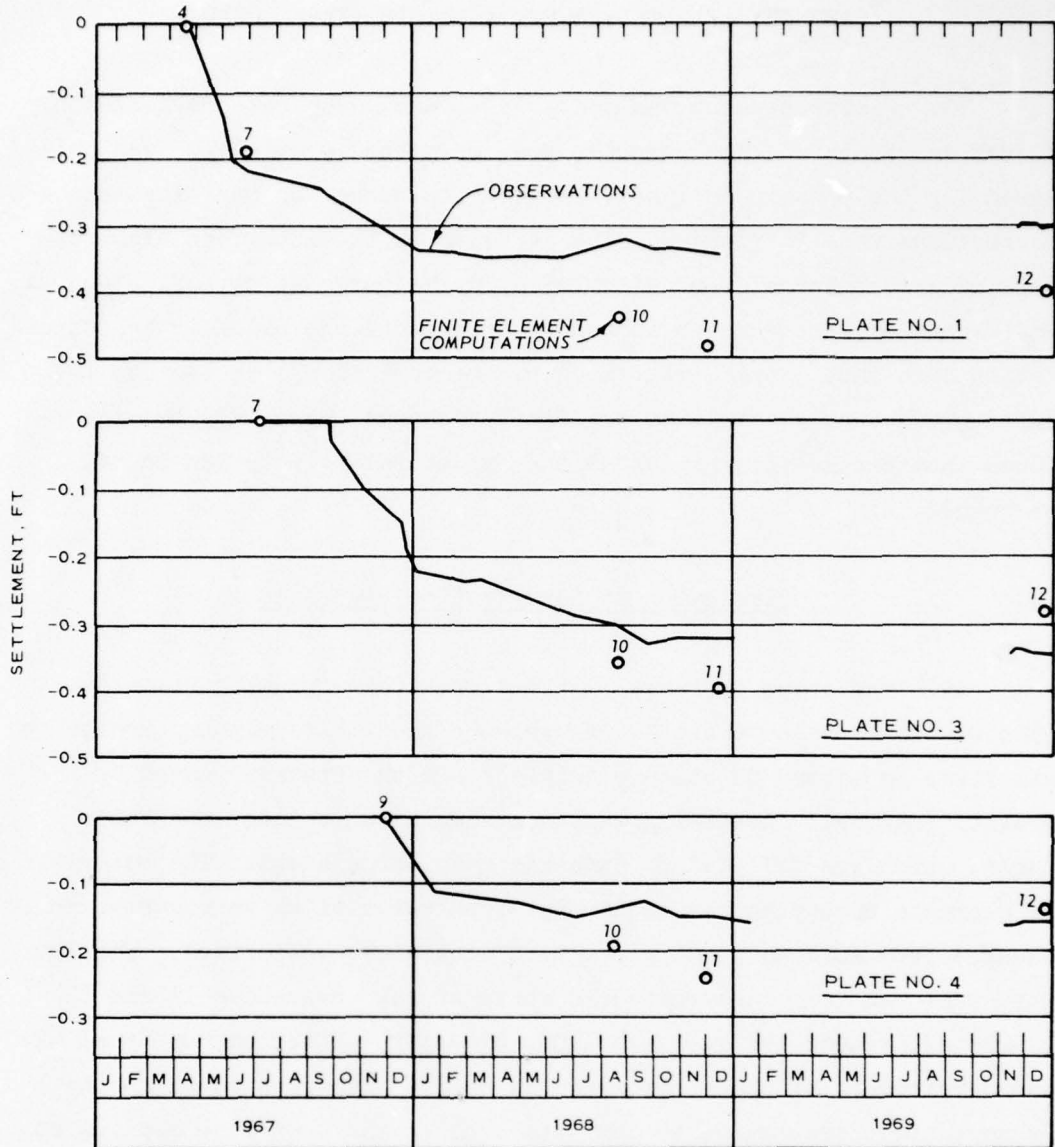

NOTE: NUMBERS INDICATE FE SEQUENCES (TABLE 2)

Fig. 8. Comparisons between predicted and observed settlements, monolith 10-L

displacements measured at nodes near typical settlement plates in the backfill adjacent to monolith 10-L (fig. 3) and the observed settlements of the plates. The FE results are shown for four stages: completion of lock wall construction, completion of backfill, filling the lock, and after the application of uplift pressures. The correlation between

observations and predictions is considered to be satisfactory. The observations showed that after water was introduced into the lock, the settlements (up to 1972) remained essentially the same or decreased in magnitude. The decrease may be due to the effect of uplift pressures. The FE computations with full uplift pressure also showed a decrease in predicted settlements.

16. In fig. 9a are shown observed and computed displacements at various locations in the backfill side that took place between the period 14 August 1968 (end of backfilling) to 7 January 1972 (during operations). The comparisons for plate 2 (fig. 3) below the heel of the monolith are not shown for clarity; the computed settlement of this plate was about -0.04 ft whereas the observed value was on the order of -0.055 ft. Although the FE computations do not provide exact simulation of natural and man-made conditions, the computed vertical displacements at typical nodes in the backfill for a short portion, from completion of the backfill (August 1968) to filling the lock (November 1968), of the foregoing period seem to follow the trends of the observations and are of the same order of magnitude, fig. 9a. These nodes are in the neighborhood of the locations of the corresponding settlement plates in the backfill, fig. 3.

17. Fig. 9b shows computed vertical displacement patterns for various stages of construction at two sections: at the base of the structure and at section B-B in the foundation. Dewatering (stage 1) showed settlements whereas at the end of excavation (stage 4), the highest rebound occurred. Subsequently the foundation showed settlements as the construction proceeded. After the structure was completed, the distribution of displacements was essentially symmetrical. At the end of backfill (stage 10), the foundation zone below monolith 10-L settled more than the zone below monolith 11-R because the backfill was provided only behind monolith 10-L. Under the uplift pressures (stage 12), the foundation settlements showed a decrease. The final settlements are, however, less than the total rebound after excavation. This seems reasonable since the approximate weight of material excavated was about 57,000 tons whereas the total applied load, including

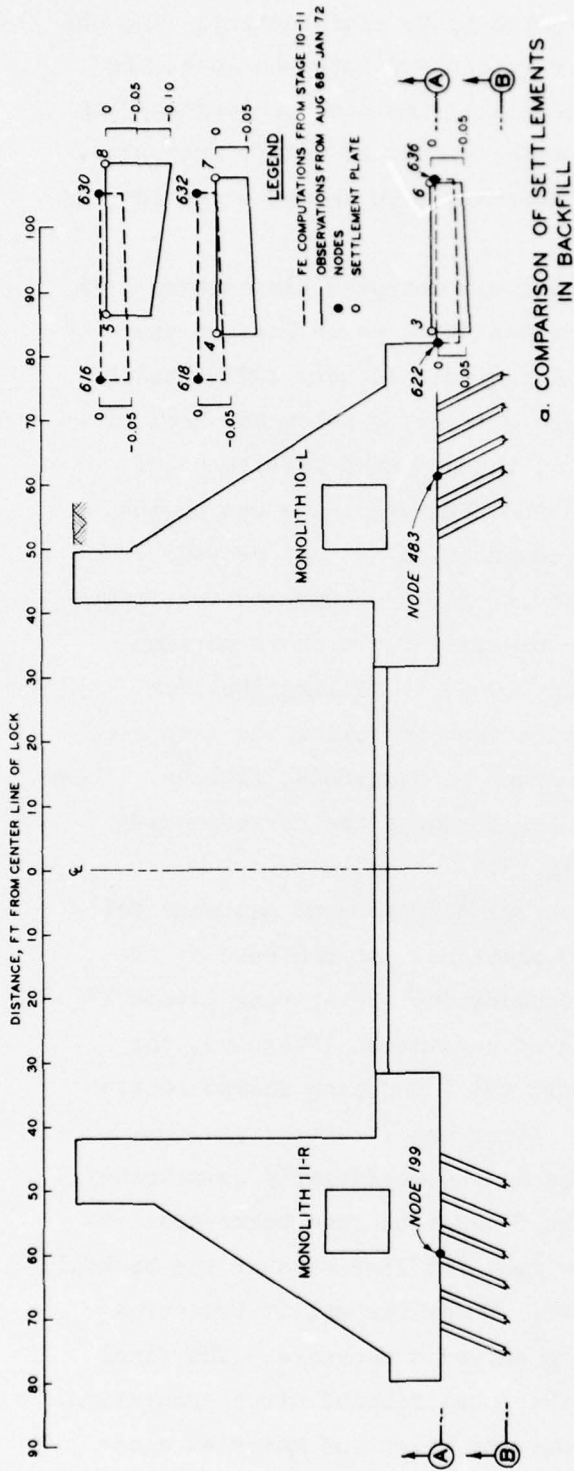

a. COMPARISON OF SETTLEMENTS IN BACKFILL

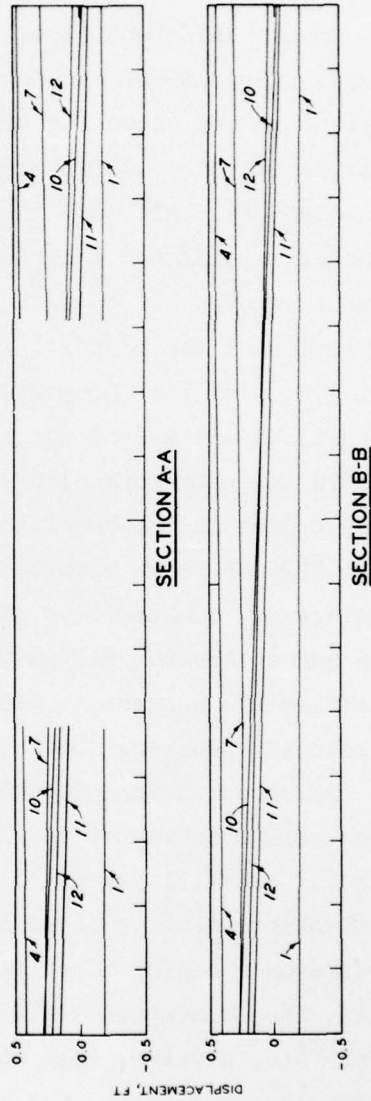

b. COMPUTED SETTLEMENTS AT VARIOUS STAGES

Fig. 9. Comparisons of settlements in backfill and computed settlement of foundation (for construction sequences, see table 2)

the structure, backfill, and water, was about 35,000 tons. The weight of the excavated material and backfill in these computations includes the entire area that was affected by excavation and backfill, as shown in the FE mesh, fig. 4.

18. Computed vertical settlements at nodes 199 and 483, fig. 9, beneath monoliths 11-R and 10-L, respectively, are shown in fig. 10. The average observed vertical displacements of settlement plates 1 and 2, monolith 10-L, fig. 3, after completion of lock construction and backfill shown in fig. 10 compare favorably with the corresponding FE results, sequences 7 and 10 in table 2. The displacements under both monoliths are about the same up to the end of lock buildup (stage 7), with monolith 10-L showing somewhat larger displacements. This may be

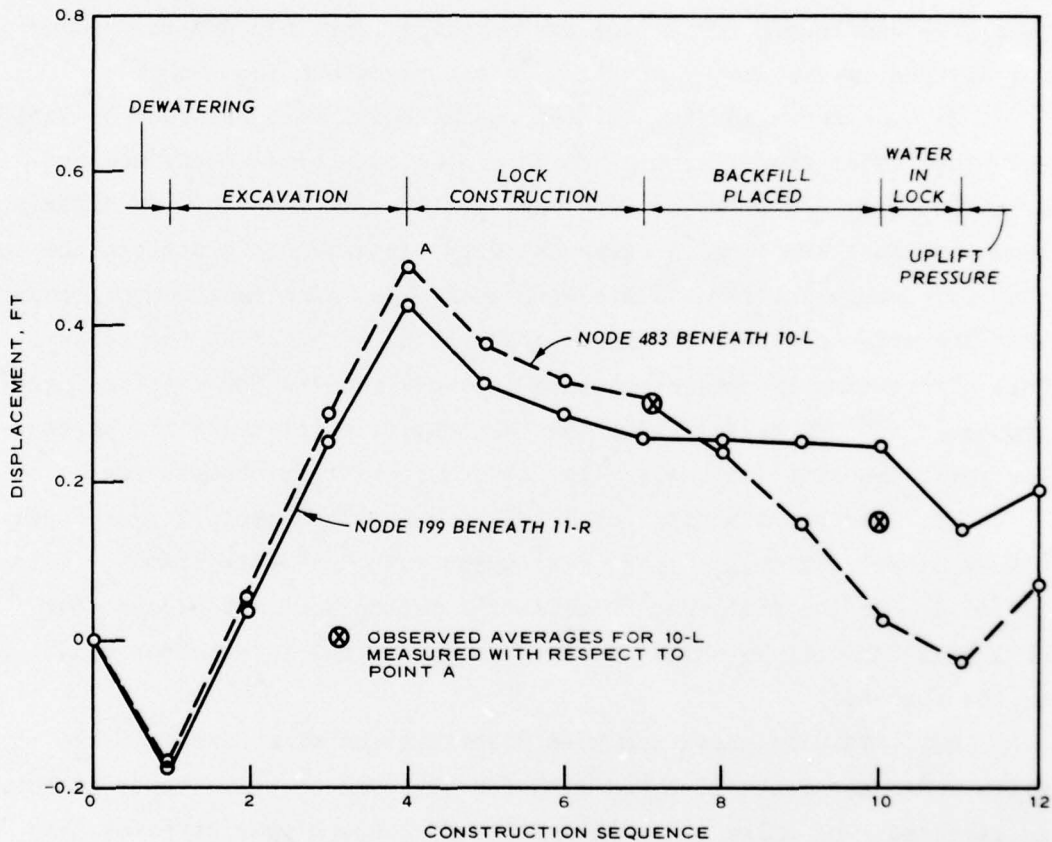

Fig. 10. Settlement versus construction sequences at typical nodes, 199 and 483, fig. 9

due to the fact that the soil beneath 10-L contains a greater depth of relatively weaker Tertiary clay as compared with the depth of substratum sands, fig. 4, than does the soil beneath 11-R. Monolith 10-L shows significantly larger displacements after the backfill behind 10-L is completed.

Loads in piles

19. Typical results for piles battered out (B piles) and battered in (A piles) are shown in fig. 11. Distributions of loads along each of the instrumented rows as computed by Hrennikoff's method³ are also shown in fig. 11.

20. An approximate value of load in a pile was obtained on the basis of the computed vertical stress in the element at the butt of the pile. This stress was multiplied by the width (1 ft) of the equivalent pile and length (40 ft) of the monolith (fig. 6), and the product was divided by the number of piles in the row along the length.

21. As shown in fig. 11, the measurements were recorded at various times after the structure was completed. In some cases, measurements for only one pile location were available. The computed distributions of loads are in good agreement with the measured distributions for the cases where sufficient data were available. The measurements showed that the outer row carried higher loads than the piles in the center. This observation is consistent with previous reports for friction pile groups.^{4,5,16} The predictions for the completion of backfill, particularly for monolith 10-L, fig. 11b, also support this observation.

22. The distributions of loads given by Hrennikoff's method are always linear and do not in general agree with the observations. This may be due to the fact that Hrennikoff's method does not account for nonlinear behavior of soils and interfaces and the interaction behavior of the system.

23. Fig. 12a shows computed distributions of stresses in the piles under monoliths 10-L and 11-R for the case of piles battered out. As expected, the piles on the backfill side show higher stresses than the piles below monolith 11-R. The stresses increase in magnitude up

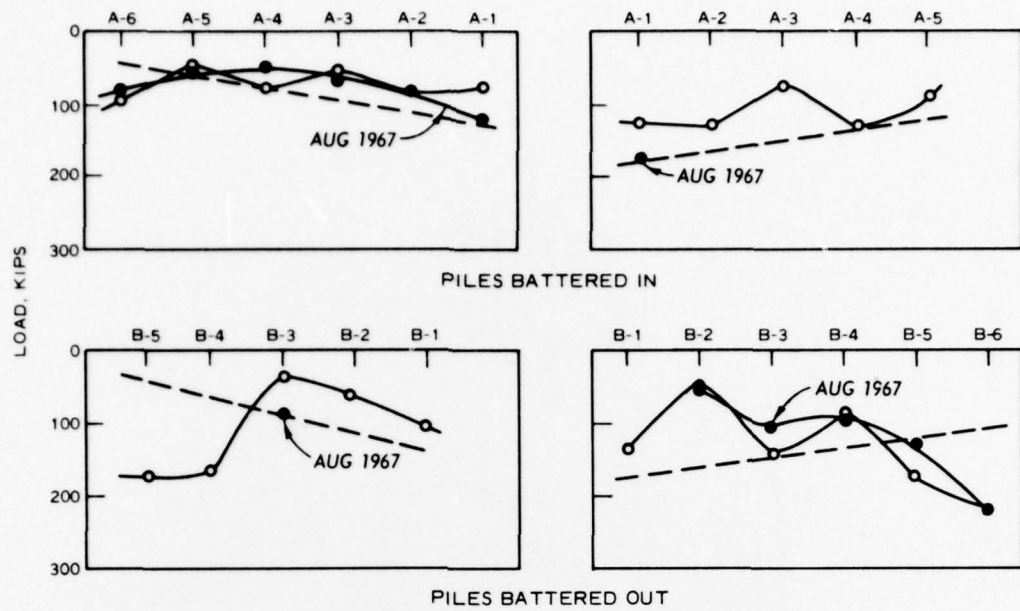

MONOLITH 10-L

MONOLITH 11-R

a. END OF LOCK CONSTRUCTION-NO BACKFILL (CASE 7)

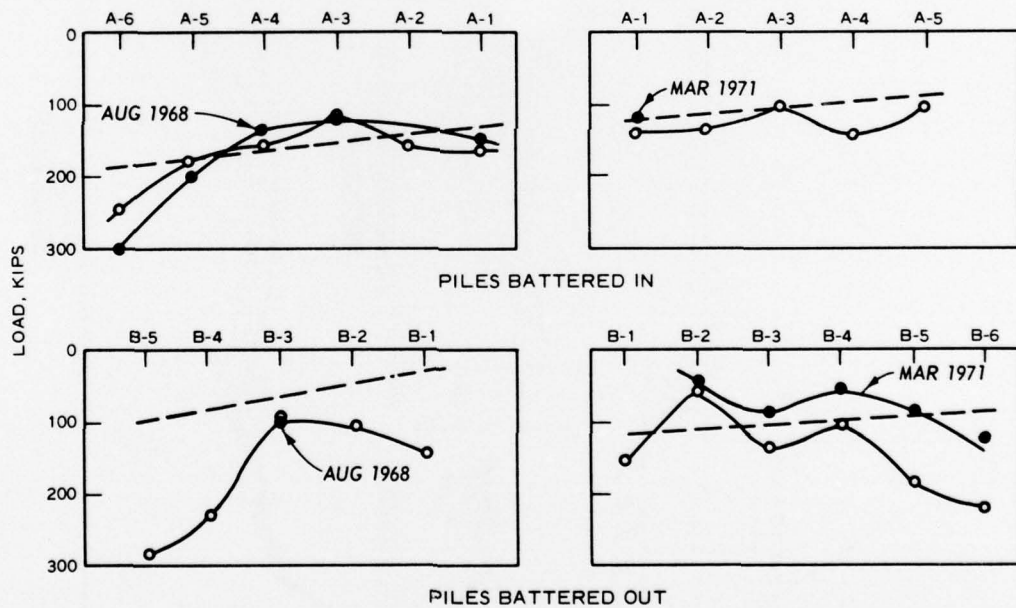

MONOLITH 10-L

MONOLITH 11-R

b. BACKFILL COMPLETE (CASE 10)

LEGEND

- MEASURED
- FINITE ELEMENT SOLUTION
- HRENNIKOFF'S METHOD

Fig. 11. Comparison between computations and field observations of distribution of loads in piles

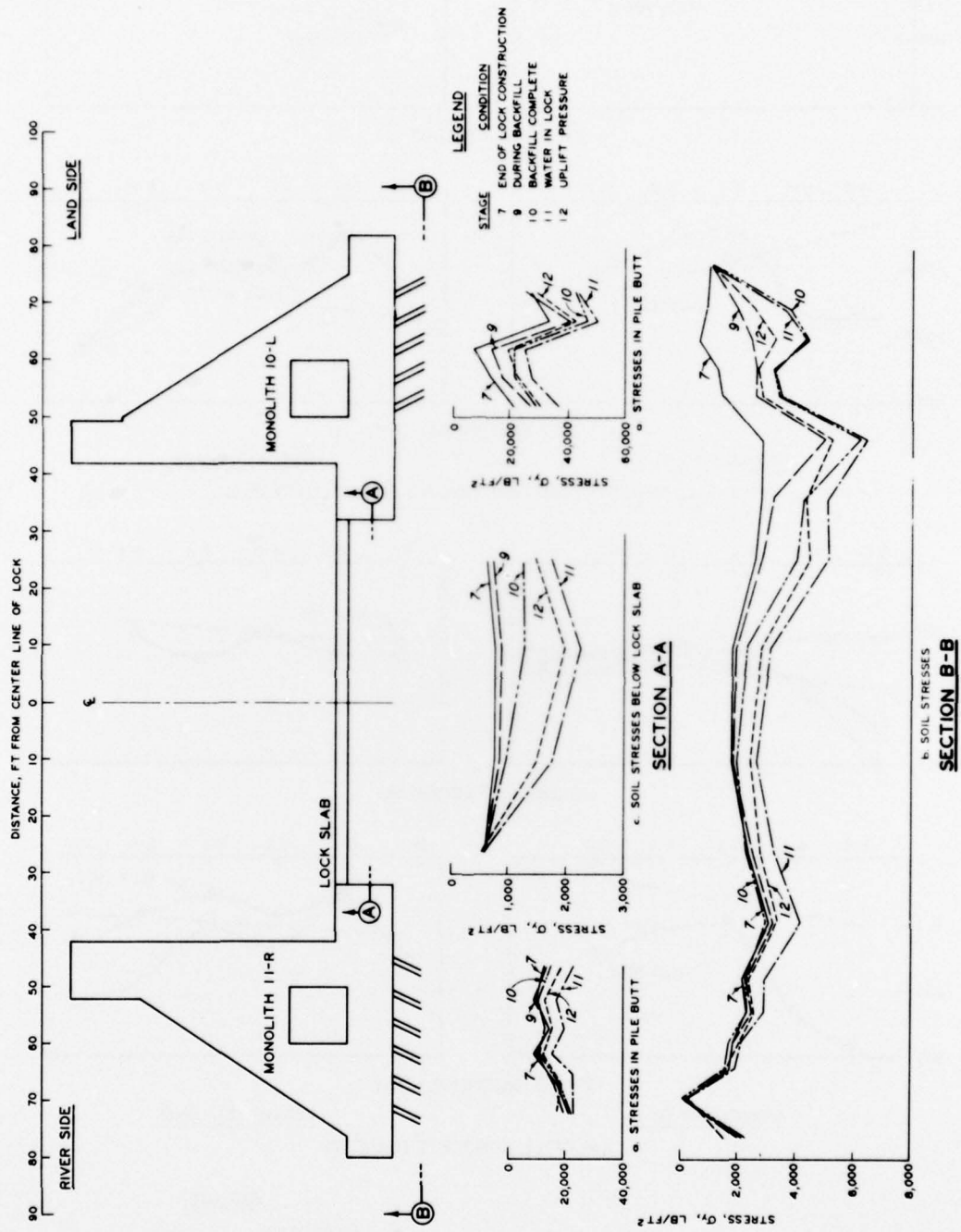

Fig. 12. Computed stress distributions in piles, foundation, and below slab

to sequence 11, water in the lock; thereafter, under uplift pressure, the stresses in the piles decrease.

Soil pressures

24. Computed distributions of vertical soil stresses in the elements at section B-B in the foundation for typical sequences are shown in fig. 12b. The soil stresses are higher under monolith 10-L, and they increase in magnitude up to sequence 11. Under uplift pressure, the soil stresses decrease in magnitude.

25. Computed distributions of vertical soil stresses in the elements immediately below the slab of the lock are shown in fig. 12c.

Lateral pressure in backfill

26. Computed distributions of the vertical and horizontal stresses in the elements along the section Y-Y in the backfill region are shown in fig. 13. The vertical stresses follow essentially the linear variation, $\sigma_y = \gamma D$, for a major portion of the depth, where σ_y = vertical stress, γ = unit weight of backfill, and D = depth of overburden. In the lower portion, however, the pressure shows a significant decrease as compared with the linear distribution. One of the reasons for such a reduction can be the existence of arching near the base of the wall. The magnitudes of σ_y decrease by small amounts from sequence 10 to 12 in the upper zones, but increase by small amounts in the lower zone.

27. The horizontal stress, σ_x , also decreases by somewhat larger amounts from sequence 10 to 12 in the upper zones at constant elevation, and increases by small amounts in the lower zone. For the major portion of the upper zone, the linear distribution, $\sigma_x = K_o^c \gamma D$, where K_o^c = coefficient of lateral earth pressure for the backfill (0.45), lies in the vicinity of the computed distributions.

Drag forces

28. Differential settlement between the backfill and the lock can cause drag forces which can increase loading on the foundation.⁴ The drag forces were computed from the FE results by summing the shear forces induced in the elements along the section Y-Y, fig. 13, adjacent to the heel of the monolith 10-L. The net value of such drag forces

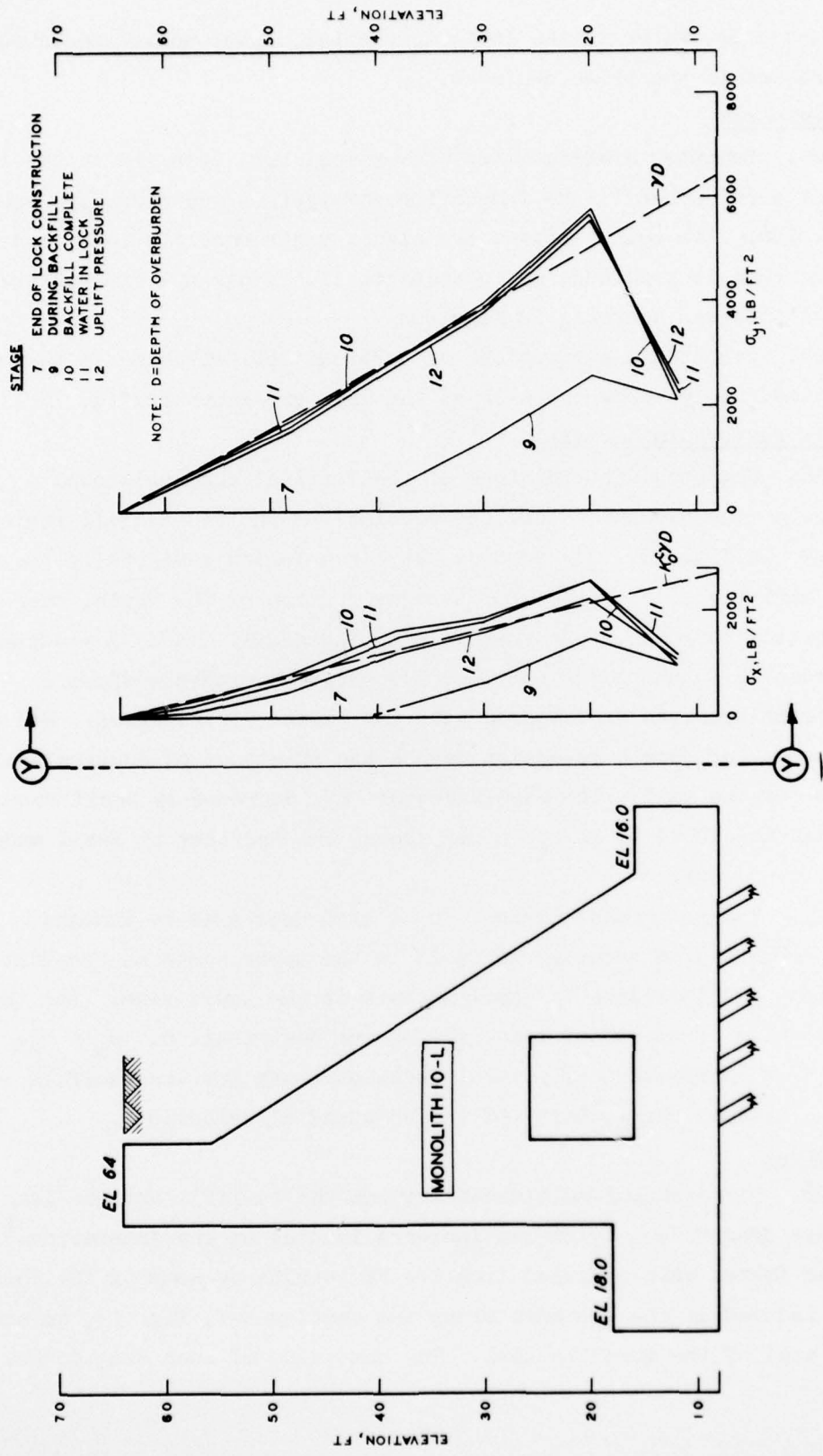

Fig. 13. Distribution of computed pressures in backfill

after the end of the sequence 11 (table 2) was obtained as equal to about 10 tons per foot. The properties of the backfill were chosen as $\phi = 40 \text{ deg}$ and $K_O^C = 0.45$ (table 1).

29. The net load applied due to the weight of monolith 10-L and the weight of the backfill over the heel was estimated to be equal to about 130 tons per foot.⁴ Hence, the drag force as a percentage of the total load appears to be about 8 percent; this value compares favorably with that of 10 percent reported in reference 4.

Comments on Formulation and Codes

30. The computer codes developed previously⁸ and used for this study can yield satisfactory results for stresses and deformations in the foundation and surrounding soils. The formulation and codes, however, may involve certain difficulties. The stresses and deformations in the structure itself and at some locations in the interface may not be realistic; consequently, interaction effects may not be studied precisely. In the formulation, it is required to employ "air" elements during various sequences of operations. Excessive displacements can occur at the nodes of these elements in comparison with the elements in the intact (foundation) elements. This may be due to the fact that the relative magnitudes of the component of the overall stiffness matrix pertaining to the air elements are much smaller in comparison with the remaining portion of the stiffness matrix related to the intact elements. As a consequence, some ill-conditioning may enter the system. The stresses in elements situated symmetrically may not be equal, and the constitutive models for soils and interfaces may require improvements. Some of these aspects are being examined currently at WES.

PART V: CONCLUSIONS AND RECOMMENDATIONS

Conclusions

31. The three-dimensional lock pile foundation system for the gravity-type Columbia Lock was idealized as a two-dimensional problem. The system was simulated by an equivalent plane-strain idealization in which a row of H-piles in the group was represented by a strip of unit width and length with equivalent (axial) stiffness properties. The sequences of construction--in situ stresses, dewatering, excavation, construction of piles and lock, backfilling, filling the lock with water, and uplift pressure--were simulated in the incremental FE analysis. Nonlinear deformation characteristics of soils and interfaces were derived from laboratory triaxial and direct shear tests, respectively, and were introduced into the FE procedure.

32. Even with the foregoing idealization to a two-dimensional system and approximations to the soil and interface parameters, the predicted behavior in terms of progressive settlements and distributions of loads in the piles showed satisfactory correlation with corresponding observations. The distribution of loads in the piles from the conventional Hrennikoff's method did not show good agreement with the pattern of load distributions, whereas the FE method showed, in general, improved correlations. It should be noted that the loading conditions and material properties assumed in the design with Hrennikoff's method may be different from those simulated in the FE analysis. The comparison herein is made only as a qualitative trend.

33. The concept of substituting for the three-dimensional system an equivalent two-dimensional system for the FE analysis seems to be satisfactory from a practical viewpoint. It shows the engineer that satisfactory predictions can be obtained by using this idealization which can provide significant savings in terms of human and computational efforts. The FE method can provide useful insight into and increased understanding of the behavior of battered pile groups for

foundations of gravity-type structures, and can be used as a tool in analysis and design.

Recommendations

34. The investigation reported herein was directed essentially to the study of stresses and deformations in the foundation soils. As remarked earlier, the present formulation and code may show local errors, and the preciseness of interface stresses may not be satisfactory. It is proposed that the formulation and code be examined thoroughly and that possible improvements be introduced. The mathematical properties of the interface element may require close scrutiny.

35. The interaction effects between the structure and soils are highly relevant from viewpoints of the design engineer. With the foregoing suggestion in paragraph 34, it will be very useful to adopt finer meshes for the structure and compute detailed distribution of stresses in the concrete structure. This will permit computation of bending moments and shear forces at critical locations. A comparison of such design quantities with the corresponding quantities based on conventional methods can be relevant.

36. The topic of group effects in pile groups is of importance from the viewpoint of design analysis. It is proposed that the finite element procedure be extended and used to examine the group effects and distribution of loads in the piles in a group and the results compared with the loading capacity of such single piles.

37. A parametric study to examine effects of such factors as different values of K_O^C , drained and undrained parameters, various mesh layouts, and interfaces at the base should be performed to assist the user in the proper choice of these quantities. Moreover, it is possible to perform trial-and-error analyses in which both the Hrennikoff's and FE methods are used under various combinations of such factors as material properties, loadings, and geometry. These can lead to better criteria for design analysis of gravity locks.

LITERATURE CITED

1. U. S. Army Engineer District, Vicksburg, "Columbia Lock, Pile Tests--Lock Site," Design Memorandum No. 6, Supplement No. 2, Dec 1963, Vicksburg, Miss.
2. _____, "Columbia Lock, Masonry and Embedded Metals," Design Memorandum No. 6, Mar 1963, Vicksburg, Miss.
3. Hrennikoff, A., "Analysis of Pile Foundations with Batter Piles," Transactions, American Society of Civil Engineers, Vol 115, Paper No. 2401, 1950, pp 351-381.
4. Montgomery, R. L. and Sullivan, A. L., Jr., "Interim Analysis of Data from Instrumentation Program, Columbia Lock," Miscellaneous Paper S-72-30, Aug 1972, U. S. Army Engineer Waterways Experiment Station, CE, Vicksburg, Miss.
5. Sherman, W. C., Jr., "The Behavior of Lock Walls Supported on Batter Piles," Proceedings, 8th International Conference on Soil Mechanics and Foundation Engineering, Moscow, Oct 1973.
6. Worth, N. L. et al., "Pile Tests, Columbia Lock and Dam, Ouachita and Black Rivers, Arkansas and Louisiana," Technical Report 3-741, Sep 1966, U. S. Army Engineer Waterways Experiment Station, CE, Vicksburg, Miss.
7. U. S. Army Engineer District, Vicksburg, "Ouachita-Black Rivers Navigation Project, Ouachita River, Louisiana, Columbia Lock and Dam," Periodic Inspection Report No. 1, Oct 1972, Vicksburg, Miss.
8. Clough, G. W. and Duncan, J. M., "Finite Element Analyses of Port Allen and Old River Locks," Contract Report S-69-6, Sep 1969, U. S. Army Engineer Waterways Experiment Station, CE, Vicksburg, Miss.; prepared under Contract No. DACW39-68-C-0040 by Lower Mississippi Valley Division, Vicksburg, Miss.
9. Desai, C. S., "Finite Element Method for Design Analysis of Deep Pile Foundations" (in preparation), U. S. Army Engineer Waterways Experiment Station, CE, Vicksburg, Miss.
10. _____, "Nonlinear Analyses Using Spline Functions," Journal, Soil Mechanics and Foundations Division, American Society of Civil Engineers, Vol 97, No. SM10, Oct 1971, pp 1461-1480.
11. _____, "Numerical Design Analysis for Piles in Sands," submitted to be published in Journal, Soil Mechanics and Foundations Division, American Society of Civil Engineers.
12. Desai, C. S. and Abel, J. F., Introduction to the Finite Element Method, Van Nostrand Reinhold Co., New York, 1972.
13. Desai, C. S. and Holloway, D. M., "Load-Deformation Analysis of Deep Pile Foundations," Proceedings, Symposium on Applications of the Finite Element Method in Geotechnical Engineering, C. S. Desai, ed., Sep 1972, pp 629-656.

14. Duncan, J. M. and Chang, C. Y., "Nonlinear Analysis of Stress and Strain in Soils," Journal, Soil Mechanics and Foundations Division, American Society of Civil Engineers, Vol 96, No. SM5, Sep 1970, pp 1629-1653.
15. Kulhawy, F. H., Duncan, J. M., and Seed, H. B., "Finite Element Analyses of Stresses in Movements in Embankments During Construction," Contract Report S-69-8, Nov 1969, U. S. Army Engineer Waterways Experiment Station, CE, Vicksburg, Miss.; prepared under Contract No. DACW39-68-C-0078, by Soil Mechanics and Bituminous Materials Laboratory, University of California, Office of Research Services, Berkeley, Calif., Report No. TE-69-4.
16. Chellis, R. D., Pile Foundations, 2d ed., McGraw-Hill, New York, 1961.

Table 1
Hyperbolic Parameters and Properties for Different Materials

<u>Material*</u>	<u>v</u>	<u>v_f</u>	<u>γ, lb/ft³</u>	<u>R_f</u>	<u>K_o^C</u>	<u>∅</u>	<u>c</u>	<u>K</u>	<u>K_u</u>	<u>n</u>
1	0.10	0.10	--	--	--	--	--	--	--	0.0
2	0.30	0.48	120.0	0.90	0.70	26	0	1000	2000	0.0
3	0.30	0.48	58.0	0.90	0.70	26	0	1000	2000	0.0
4	0.30	0.48	53.0	0.85	0.45	40	0	1160	1750	0.5
5	0.30	0.48	58.0	0.85	1.10	30	0	400	800	0.5
6	0.28	0.28	61.0	1.00	1.00	--	--	--	--	--
7	0.28	0.28	66.0	1.00	1.00	--	--	--	--	--
8	0.10	0.10	0.0	--	--	--	--	--	--	0.0
9	0.20	0.20	150.0	--	1.00	--	--	--	--	--
10	0.30	0.48	115.0	0.85	0.45	40	0	580	860	0.5
11	0.48	0.48	62.4	1.00	1.00	--	--	--	--	0.0

Note: v = Poisson's ratio.

v_f = Poisson's ratio at failure.

γ = unit weight.

R_f = failure ratio.

K_o^C = coefficient of earth pressure in compression.

∅ = Mohr-Coulomb (angle of internal friction) parameter.

c = Mohr-Coulomb cohesive strength parameter.

K = hyperbolic loading parameter.

K_u = hyperbolic unloading parameter.

n = experimentally determined parameter.

<u>* Material</u>	<u>Identification</u>
1	Air
2	Backswamp clay above water table
3	Backswamp clay below water table
4	Substratum sand
5	Tertiary clay
6	Equivalent piles - 11-R
7	Equivalent piles - 10-L
8	Air as replacement
9	Concrete
10	Backfill sand
11	Water

Table 2
Sequences Simulated in Finite Element Analyses

Operation	Details	Sequences
Initial stresses	--	--
Dewatering	From el 34.0* to el 5.0	1
Excavation	In three stages:	
	El 58.0 to 42.0	2
	El 42.0 to 26.0	3
	El 26.0 to 8.0	4
Placement of piles	--	5a
Lock construction	In three stages:	
	El 8.0 to 26.0	5b
	El 26.0 to 42.0	6
	El 42.0 to 64.0	7
Backfill	In three stages:	
	El 8.0 to 26.0	8
	El 26.0 to 42.0	9
	El 42.0 to 64.0	10
Filling of the lock	--	11
Development of uplift pressure	--	12

* All elevations (el) cited herein are in feet referred to mean sea level.

In accordance with ER 70-2-3, paragraph 6c(1)(b), dated 15 February 1973, a facsimile catalog card in Library of Congress format is reproduced below.

Desai, Chandrakant S

Finite element analysis of the Columbia Lock pile foundation system, by C. S. Desai, L. D. Johnson and C. M. Hargett. Vicksburg, U. S. Army Engineer Waterways Experiment Station, 1974.

1 v. (various pagings) illus. 27 cm. (U. S. Waterways Experiment Station. Technical report S-74-6)

Sponsored by U. S. Army Engineer District, Vicksburg. Includes bibliography.

1. Columbia Lock. 2. Computer applications. 3. Finite element method. 4. Foundations. 5. Load distribution. 6. Locks (Waterways). 7. Pile foundations. 8. Pile groups. 9. Settlement (Structural). 10. U-frame locks. I. Johnson, Lawrence D., joint author. II. Hargett, Charles M., joint author. III. U. S. Army Engineer District, Vicksburg. (Series: U. S. Waterways Experiment Station, Vicksburg, Miss. Technical report S-74-6)
TA7.W34 no.S-74-6