

AD-A049 525

SYSTEMS RESEARCH LABS INC DAYTON OHIO

F/G 4/2

AFAL TOWER CHARACTERIZATION FACILITY: 4-KM WEATHER INSTRUMENTAT--ETC(U)

AUG 77 W R CHASE

F33615-76-C-1092

UNCLASSIFIED

SRL-6908

AFAL-TR-77-162

NL

| OF |

AD
A049 525

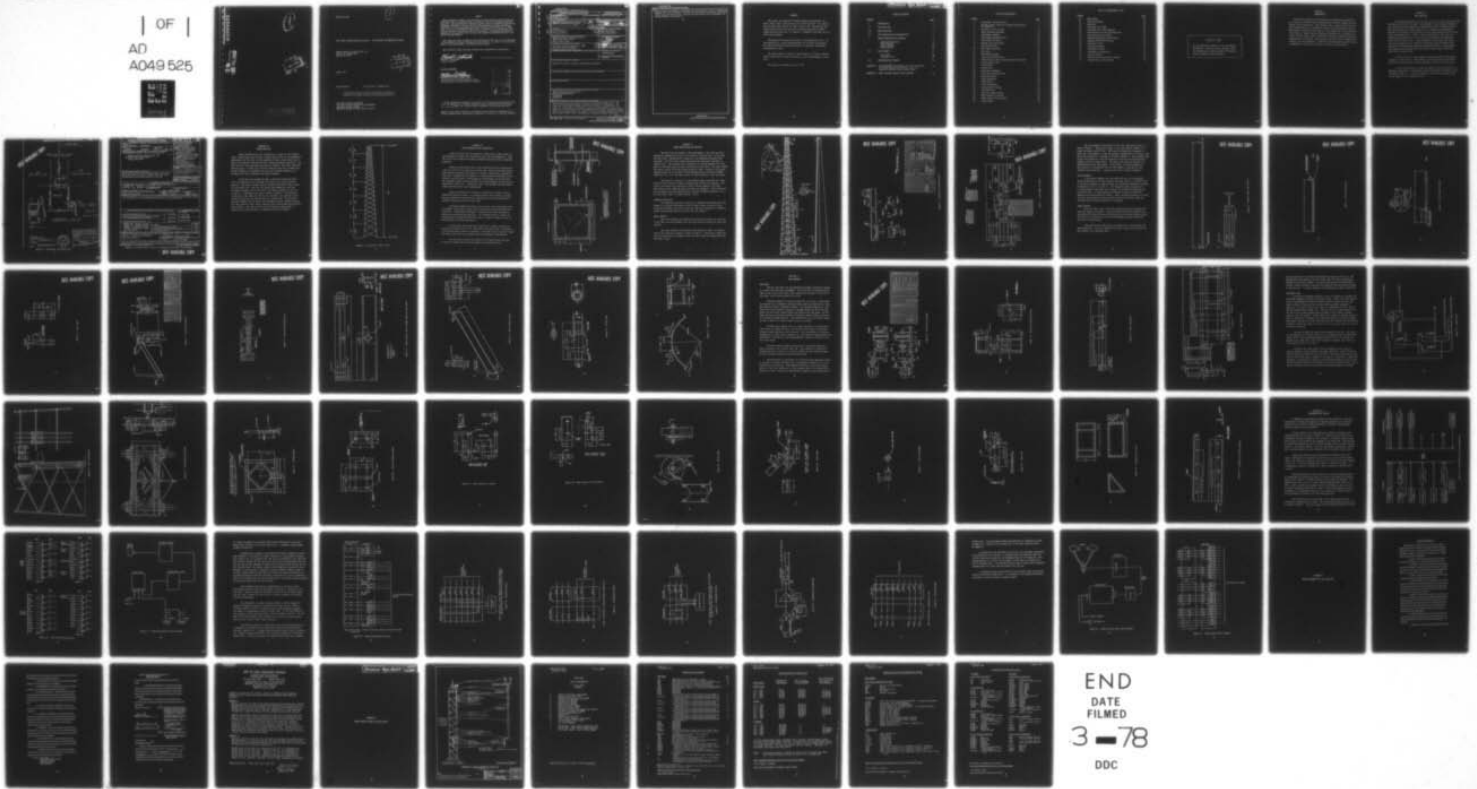

END
DATE
FILMED
3 - 78
DDC

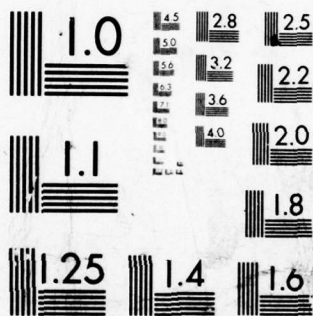

MICROCOPY RESOLUTION TEST CHART
NATIONAL BUREAU OF STANDARDS-1963-A

AD A 049525

AD No.

JDC FILE COPY

1
B.S.

BDC
FEB 2 1978
F

DECLASSIFICATION STATEMENT A
Approved for public release
Distribution Unlimited

AFAL-TR-77-162

①

AFAL TOWER CHARACTERIZATION FACILITY: 4-KM WEATHER INSTRUMENTATION TOWER

Systems Research Laboratories, Inc.
2800 Indian Ripple Road
Dayton, OH 45440

DDC
RECEIVED
FEB 2 1978
F

August 1977

Interim Report

1 April 1976 - 30 March 1977

Approved for public release; distribution unlimited.

AIR FORCE AVIONICS LABORATORY
AIR FORCE WRIGHT AERONAUTICAL LABORATORIES
AIR FORCE SYSTEMS COMMAND
WRIGHT-PATTERSON AIR FORCE BASE, OH 45433

NOTICE

When Government drawings, specifications, or other data are used for any purpose other than in connection with a definitely related Government procurement operation, the United States Government thereby incurs no responsibility nor any obligation whatsoever; and the fact that the government may have formulated, furnished, or in any way supplied the said drawings, specifications, or other data, is not to be regarded by implication or otherwise as in any manner licensing the holder or any other person or corporation, or conveying any rights or permission to manufacture, use, or sell any patented invention that may in any way be related thereto.

This report has been reviewed by the Information Office (OI) and is releasable to the National Technical Information Service (NTIS). At NTIS, it will be available to the general public, including foreign nations.

This technical report has been reviewed and is approved for publication.

Harold E. Geltmacher

Harold E. Geltmacher
Project Engineer

FOR THE COMMANDER

William A. Wallace

William A. Wallace, LTCOL, USAF
Electro-Optics and Reconnaissance Branch
Reconnaissance and Weapon Delivery Division

ACCESSION for	
NTIS	Wide Section <input checked="" type="checkbox"/>
DDC	Brief Section <input type="checkbox"/>
UNANNOUNCED	<input type="checkbox"/>
JUSTIFICATION	
BY	
DISTRIBUTION/AVAILABILITY CODES	
T and/or SPECIAL	
A	-

"If your address has changed, if you wish to be removed from our mailing list, or if the addressee is no longer employed by your organization please notify _____, W-PAFB, OH 45433 to help us maintain a current mailing list".

Copies of this report should not be returned unless return is required by security considerations, contractual obligations, or notice on a specific document.

UNCLASSIFIED

SECURITY CLASSIFICATION OF THIS PAGE (When Data Entered)

19 REPORT DOCUMENTATION PAGE		READ INSTRUCTIONS BEFORE COMPLETING FORM	
1. REPORT NUMBER 18 AFAL-TR-77-162 ✓	2. GOVT ACCESSION NO.	3. RECIPIENT'S CATALOG NUMBER	
4. TITLE (and Subtitle) 6 AFAL TOWER CHARACTERIZATION FACILITY: 4 km WEATHER INSTRUMENTATION TOWER.		5. TYPE OF REPORT & PERIOD COVERED 9 Interim rept. 1 Apr 76 - 30 Mar 77	
7. AUTHOR(s) 10 Wayne R./Chase		8. PERFORMING ORG. REPORT NUMBER 14 SRL-6908	
9. PERFORMING ORGANIZATION NAME AND ADDRESS Systems Research Laboratories, Inc. 2800 Indian Ripple Road Dayton, Ohio 45440		10. PROGRAM ELEMENT, PROJECT, TASK AREA & WORK UNIT NUMBERS 15 F33615-76-C-1092 New Proj. No. 2004 Task No. 0503	
11. CONTROLLING OFFICE NAME AND ADDRESS Air Force Avionics Laboratory (RWI) Air Force Systems Command Wright-Patterson AFB, OH 45433		12. REPORT DATE 11 Aug 77 12/79p	
14. MONITORING AGENCY NAME & ADDRESS (if different from Controlling Office)		13. NUMBER OF PAGES 77	
16. DISTRIBUTION STATEMENT (of this Report) Approved for public release; distribution unlimited.		15. SECURITY CLASS. (of this report) UNCLASSIFIED	
17. DISTRIBUTION STATEMENT (of the abstract entered in Block 20, if different from Report)		15a. DECLASSIFICATION/DOWNGRADING SCHEDULE	
18. SUPPLEMENTARY NOTES			
19. KEY WORDS (Continue on reverse side if necessary and identify by block number) TOWER CHARACTERIZATION FACILITY WEATHER INSTRUMENTATION EO SENSORS ATMOSPHERE			
20. ABSTRACT (Continue on reverse side if necessary and identify by block number) A 130-ft high tower has been erected at the mid-point (4-km) of the AFAL Tower Characterization Facility to support weather instrumentation. The tower has an instrument package which can be lowered to ground level for repair or replacement of instruments, and then raised again to the top for operation. The instrument cart is designed so that other instrument packages can be easily substituted. The present instrument package includes the following: forward scatter meter, pyranometer, continuous-reading pluviometer, (cont.)			

UNCLASSIFIED

SECURITY CLASSIFICATION OF THIS PAGE(When Data Entered)

tipping bucket pluviometer, wind-speed and wind-direction sensors, temperature dewpoint set, and thermometer. The data collected from this weather instrumentation tower are being used to characterize the effects of the atmosphere on the performance of EO sensors.



UNCLASSIFIED

SECURITY CLASSIFICATION OF THIS PAGE(When Data Entered)

FOREWORD

This report was prepared by Systems Research Laboratories, Inc. (SRL), Dayton, Ohio, under Contract No. F33615-76-C-1092. The contract was initiated under Project No. 2004, Task No. 503. The work was performed under direction of the Air Force Avionics Laboratory (AFAL), Wright-Patterson AFB, Ohio. Mr. Harold E. Geltmacher (AFAL/RWI) was the AFAL Project Manager.

The program was conducted from April 1976 through March 1977. Mr. John Weinhold was the SRL Program Manager and Principal Investigator. Mr. Wayne Chase was Principal Investigator on Task 503, 4-KM Weather Instrumentation Tower.

The author wishes to thank Mr. Elmer Harbert, Mr. Michael Johnson, and Mr. Wayne Lewis for their assistance in the accomplishment of this task.

This report was submitted in April 1977.

TABLE OF CONTENTS

SECTION		PAGE
I	INTRODUCTION	1
II	SITE SELECTION	2
III	TOWER SELECTION	5
IV	SITE PREPARATION AND CONSTRUCTION	7
V	TOWER PREPARATION AND ERECTION	9
	Lightning Protection	9
	Track Assembly	9
	Pulley Assembly	13
	Tower Erection	13
VI	CART ASSEMBLY	24
	Cart Drive	24
	Instrument Cart	29
VII	INSTRUMENTATION PACKAGE	43
APPENDIX A:	LEASE AGREEMENT (Description of Land to be Leased to Systems Research Laboratories, Inc., by Bertha M. Herbruck, Greene County, Ohio)	57
APPENDIX B:	ROHN LIGHTNING CONTROL SPECIFICATIONS	63

LIST OF ILLUSTRATIONS

FIGURE		PAGE
1	Survey Map, 4-km Tower Site	3
2	FAA Form 7460-1, Notice of Proposed Construction or Alteration	4
3	Pictorial of 130 ft Tower	6
4	Tower Foundation Assembly	8
5	Tower/Rails Assembly	10
6	Tower/Rails Assembly Detail	11
7	Cross Beams for Rails	12
8	Weather Tower Rail Detail	14
9	Rail (Top Section)	15
10	Rail (Bottom Section)	16
11	Rail Cleat	17
12	Top Pulley Assembly	18
13	Cross Brace Modification	19
14	Pulley Support, Rails (Right Hand and Left Hand)	20
15	Pulley Support Brace	21
16	Pulley Shaft	22
17	Pulley Guard	23
18	Winch Drive Assembly	25
19	Winch Drum Bearing Bracket	26
20	Winch Drum Shaft	27
21	Power Winch Base	28
22	Brake Wiring	30
23	Cable and Pulleys	31
24	Cart Assembly Carriage	32
25	Carriage Frame	33
26	Cable Attachment Bracket	34
27	Wheel Bracket (4 inches)	35
28	Wheel Bracket (2-1/2 inches)	36
29	Safety Brake	37

LIST OF ILLUSTRATIONS (cont.)

FIGURE		PAGE
30	Brake Wedge	38
31	Brake Arm Bushing	39
32	Brake Arm	40
33	Instrument Cart Frame	41
34	Instrument Cart Angle Brackets	42
35	Block Diagram of 4-km Instrumentation	44
36	Distribution Center Wiring	45
37	Temperature/Dewpoint Block Diagram	46
38	Temperature/Dew-Point Wiring	48
39	Barometer Wiring	49
40	Pluviometer Wiring	50
41	Pyranometer Wiring	51
42	Pyranometer Log Amplifier	52
43	Wind Set Wiring	53
44	Forward Scatter Meter Block Diagram	55
45	Forward Scatter Meter Wiring	56

CAUTION

115 Vac externally supplied to all cart mounted instruments. Throw all circuit breakers except air conditioner and beacon light to OFF position prior to working on any instrument.

SECTION I
INTRODUCTION

This interim technical report discusses the design and construction of a portion of the AFAL Tower Characterization Facility, namely the 4-km weather tower installation. This 130-foot tower, complete with an instrument package which can be raised and lowered, is now operational, and is being used to characterize the effects of the atmosphere on the performance of EO sensors. Weather characterization instruments now in operation include a forward scatter meter, pyranometer, continuous-reading pluviometer, tipping-bucket pluviometer, wind speed and direction sensors, temperature/dewpoint set, and thermometer. Additional instrumentation planned includes a nephelometer, particle size counter, and drop size distrometer.

SECTION II
SITE SELECTION

The desired position for the initial tower of the Tower Characterization Facility was on the line of sight at the midpoint of the present 8-kilometer test facility which has endpoints at Building 620, Area B, Wright-Patterson AFB, and Building 356, Trebein Reservation. Fortunately the approximate midpoint of the facility is located in a vacant field which has direct access from a residential street. Figure 1 shows a survey map of the 4-km site, including the 0.080-acre (50 ft by 70 ft) access area and the 0.009-acre (20 ft by 20 ft) tower area. It was necessary to locate the tower 50 feet east of the property line to maintain the distance from the nearest house required by the Beavercreek Township Zoning Appeals Board. Zoning Appeals Board approval was required since the 130-foot tower exceeds the 90-foot limit set by township rules.

The tower site was leased through an agreement which is included as Appendix A to this report. The agreement covers a ten-year period through an initial three-year term and seven additional periods of one year each.

It was also necessary to obtain FAA approval for the tower prior to beginning construction. The approval was received without difficulty, and is included as Figure 2. It will be necessary to extend this agreement prior to the October 9, 1977, expiration date.

NOTICE OF PROPOSED CONSTRUCTION OR ALTERATION

1. NATURE OF STRUCTURE (Complete both A and B below)

A. (Check one)
 NEW CONSTRUCTION ALTERATION

B. (Check one) (State length of time) 120 Mos.
 PERMANENT TEMPORARY

2. NAME AND ADDRESS OF INDIVIDUAL, COMPANY, CORPORATION, ETC. PROPOSING THE CONSTRUCTION OR ALTERATION (Number, Street, City, State and Zip Code)

Systems Research Laboratories, Inc.
 TO 2800 Indian Ripple Road
 Dayton, OH 45440

FAA will either return this form or issue a separate acknowledgement.

A. The proposed structure:
 Does not require a notice to FAA.
 Would not exceed any obstruction standard of Part 77 and would not be a hazard to air navigation.
 Should be obstruction marked lighted per FAA Advisory Circular 70/7460-1, Chapter(s) _____
 Obstruction marking and lighting are not necessary.
 Requires supplemental notice. Use FAA form enclosed.
B. FCC was was not advised.

REMARKS:
 This determination expires October 9, 1977 unless otherwise extended, revised or terminated.

ISSUING OFFICER: Jes Placno, JLL
 REVIEWING OFFICER: David R. Deppa DATE: 4/9/76

3. TYPE AND COMPLETE DESCRIPTION OF STRUCTURE
 One structural steel tower manufactured by Rohn Manufacturing, Peoria, Illinois, 61606, 130' tall with meteorological instrument package at the top.

4. LOCATION OF STRUCTURE

A. COORDINATES (To nearest second)

LATITUDE		LONGITUDE	
39	46	3.3	84 2 7

B. NEAREST CITY OR TOWN, AND STATE
 Fairborn, Ohio

(1) DISTANCE FROM 4B (2) DIRECTION FROM 4B
 1.0 MILES south

C. NAME OF NEAREST AIRPORT, HELIPORT, OR SEAPLANE BASE
 Wright-Patterson AFB

(1) DISTANCE FROM NEAREST POINT OF NEAREST RUNWAY (2) DIRECTION FROM AIRPORT
 3.0 miles south

D. DESCRIPTION OF LOCATION OF SITE WITH RESPECT TO HIGHWAYS, STREETS, AIRPORTS, PROMINENT TERRAIN FEATURES, EXISTING STRUCTURES, ETC. (Attach a highway, street, or any other appropriate map or scaled drawing showing the relationship of construction site to nearest airport(s). If more space is required, continue on a separate sheet of paper and attach to this notice.)

5. HEIGHT AND ELEVATION (Complete A, B and C to the nearest foot)

A. ELEVATION OF SITE ABOVE MEAN SEA LEVEL	910 feet
B. HEIGHT OF STRUCTURE INCLUDING APPURTENANCES AND LIGHTING (if any) ABOVE GROUND, OR WATER IF SO SITUATED	138 feet
C. OVERALL HEIGHT ABOVE MEAN SEA LEVEL (A+B)	1048 feet

6. WORK SCHEDULE DATES

A. WILL START	1 May 1976
B. WILL COMPLETE	30 May 1976

7. OBSTRUCTION MARKED AND/OR LIGHTED IN ACCORDANCE WITH CURRENT FAA ADVISORY CIRCULAR 70/7460-1, OBSTRUCTION MARKING AND LIGHTING

A. MARKED	YES	NO
B. AVIATION RED OBSTRUCTION LIGHTS		X
C. HIGH INTENSITY WHITE OBSTRUCTION LIGHTS		X
D. DUAL LIGHTING SYSTEM		X

I HEREBY CERTIFY that all of the above statements made by me are true, complete, and correct to the best of my knowledge.

8. NAME AND TITLE OF PERSON FILING THIS NOTICE (Type or Print)
 William K. Bishoff, Vice President - Legal and Contracts

9. SIGNATURE (In ink)

10. DATE OF SIGNATURE **11. TELEPHONE NO. (Precede with area code)**
 5/4/76 (513) 426 6000

Persons who knowingly and willfully fail to comply with the provisions of the Federal Aviation Regulations Part 77 are liable to a fine of \$500 for the first offense, with increased Penalties thereafter as provided by Section 902(a) of the Federal Aviation Act of 1958 as amended.

Figure 2. FAA Form 7460-1, Notice of Proposed Construction or Alteration

4 **BEST AVAILABLE COPY**

SECTION III TOWER SELECTION

Several manufacturers were considered as a source for the 130-foot tower. Guyed towers were, however, quickly ruled out due to the landowner's stipulation that the tower be free-standing so that he could retain use of more of his property than possible with a tower supported by guy wires. Two basic types of free-standing structures were studied: open style flat-face and pole style. An open style flat-face type was chosen as it seemed most readily adaptable to accommodate the cart and instrument package (up to 16 square feet wind loading and 700 pounds) proposed.

A Rohn SSV tower designed by Rohn to meet EIA Standard RS-222-B for a 40 pound/square foot (100 mph) wind load for our design load was selected. This means a design load for 100 mph winds with a safety factor of 1.65 beyond that. Note that the design load included the cart and instrument package plus the track and cross beams necessary for the cart to ride on. A drawing of the tower is shown in Figure 3. The sections utilized are 12NH, 11NH, 10N, 9N, 8N, 7N, and 6N-S. The suffixes H and S stand for heavy duty and one-half section, respectively. The tower was purchased complete with an anchor bolt assembly, an RA-1C conduit lighting kit, and a Rohn-loc cable safety climbing device meeting OSHA specifications and standards. The tower was also factory painted in seven bands of International Orange and White in compliance with FAA standards.

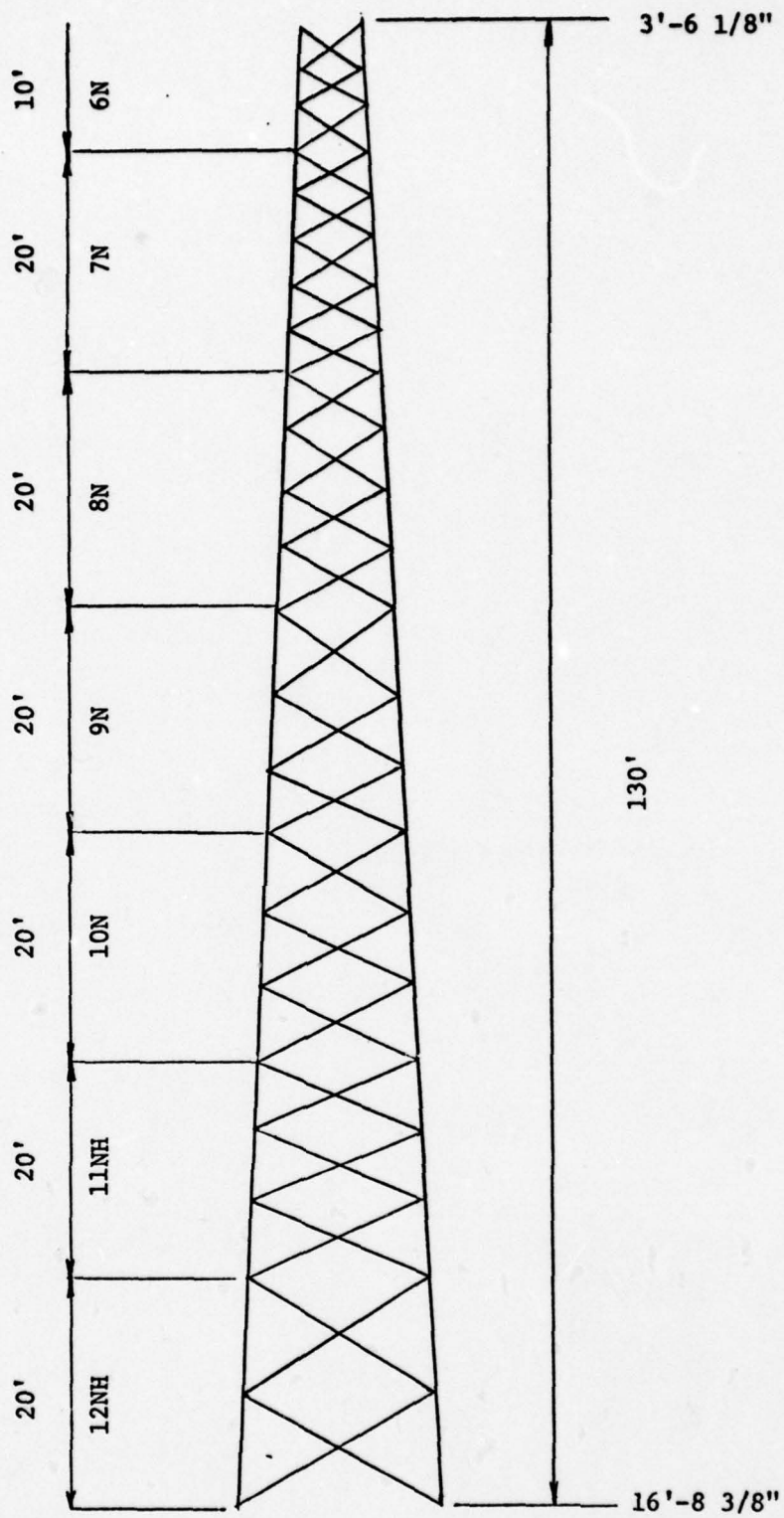

Figure 3. Pictorial of 130 ft Tower

SECTION IV
SITE PREPARATION AND CONSTRUCTION

Since the tower site is located in a field used to graze cattle, it was necessary to isolate the construction area from the grazing area. Thus one of the first tasks was to string a temporary barb wire fence around the perimeter.

Another initial major task in site preparation was the excavation of a 20 ft by 20 ft by 5 ft hole for the tower pad. This hole was then filled with reinforced concrete (see Figure 4), with the anchor bolts installed at this time. A ground wire was placed in a trench around the perimeter at the bottom of the hole prior to installing the reinforcement rod and concrete. The completed concrete pad was allowed to cure approximately 30 days prior to erecting the tower on it. During this time, tower assembly and other major tasks (discussed later) were accomplished.

Other site preparation consisted of installing a 200-amp, 230-volt underground electric service. A temporary service was initially installed, and upon completion of construction a permanent service was installed in a building fabricated within the tower legs.

Following assembly and erection of the tower (to be discussed later), a triangular flat-roofed concrete block building was constructed within the tower legs. A combination heating/air conditioning unit was installed to provide year-round working capability. The building provides a center for processing data relayed down the tower cable, as well as a home for the control portions of certain instruments.

A 6-foot high chain-link fence topped with 3 strands of barb wire was erected around the 20' by 20' tower pad in accordance with a requirement of the Zoning Appeals Board. In addition, a farm-type fence was erected around the entire access area in accordance with the landowner's requirements.

A 6-inch layer of gravel was placed in the common access area and on the area leading from the paved roadway to the fenced-in area.

BEST AVAILABLE COPY

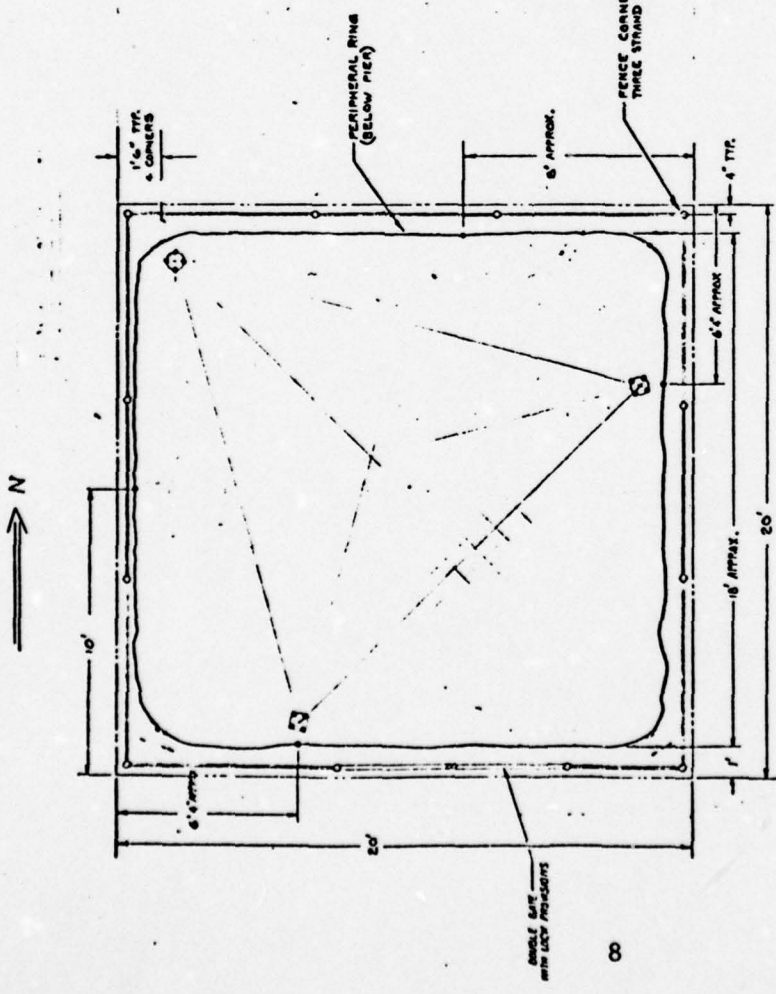
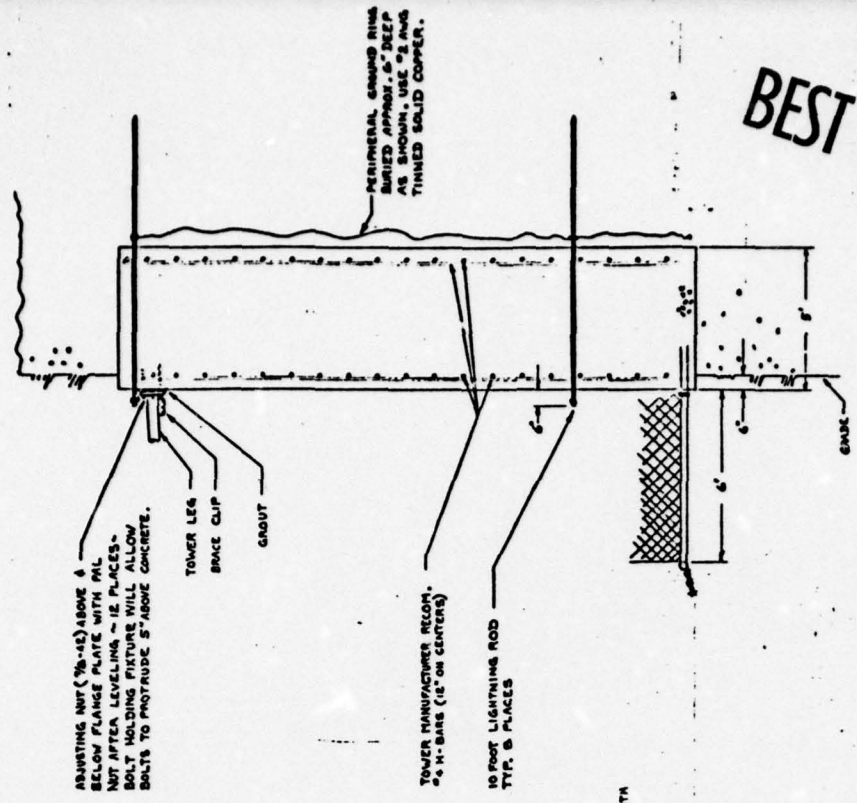

- NOTE:
1. ALL CONCRETE REINFORCEMENT TO ALSO BE ELECTRICALLY TIED TO PERIPHERAL GROUND.
 2. CONCRETE TO BE 3,000 P.S.I. MIN. ULTIMATE STRENGTH.
 3. GROUND CONNECTION TO TOWER FLANGE PLATES (S) & GROUND RODS TO BE CABLEBOLTED OR EQUIVALENT. SEE DETAIL OF CONNECTION OF TOWER ON SUB. SEE Dwg. #100644 FOR PLAN VIEW.

Figure 4. Tower Foundation Assembly

SECTION V
TOWER PREPARATION AND ERECTION

The Rohn tower was shipped to SRL disassembled. The tower was first completely assembled lying flat on the ground at the 4-km site. At this time the step bolts, climbing device, beacon kit, and lightning protection were installed. The first three items listed above were purchased from Rohn as complete kits. The climbing device consists of a 3/8-inch diameter wire rope which is stretched along the tower leg having the step bolts. The tower climber then wears a safety belt which slides along the cable. Details of this safety climbing device can be obtained from Rohn Manufacturing, Division of UNARCO Industries, Inc., P.O. Box 2000, Peoria, IL 61601 (Form Nos. 74477 and 74537).

The beacon kit consists of a non-blinking light controlled by a photoelectric cell so that the light is automatically turned on as required. The wires to the beacon were installed in steel conduit clamped to the tower. Some details of the lighting package are shown in Appendix B. More information may be obtained from Rohn Manufacturing, Division of UNARCO Industries, Inc., P.O. Box 2000, Peoria, IL 61601 (Form No. 74474).

LIGHTNING PROTECTION

The lightning protection consists of a lightning rod mounted above the height of the tallest instrument and also slightly above the beacon light. A separate grounding cable was run down the tower and attached to a peripheral ground ring installed around the tower base (see Figure 4).

TRACK ASSEMBLY

The track assembly was designed and fabricated by SRL to be custom-fit to the tower, and was assembled onto the tower prior to lifting the tower into position.

The track assembly was fabricated from aluminum I beams. An overall view of the tower/rail assembly is shown in Figure 5. Three-inch I beams were used for supporting cross members, while the rail (track) was fabricated from four-inch I beams.

BEST AVAILABLE COPY

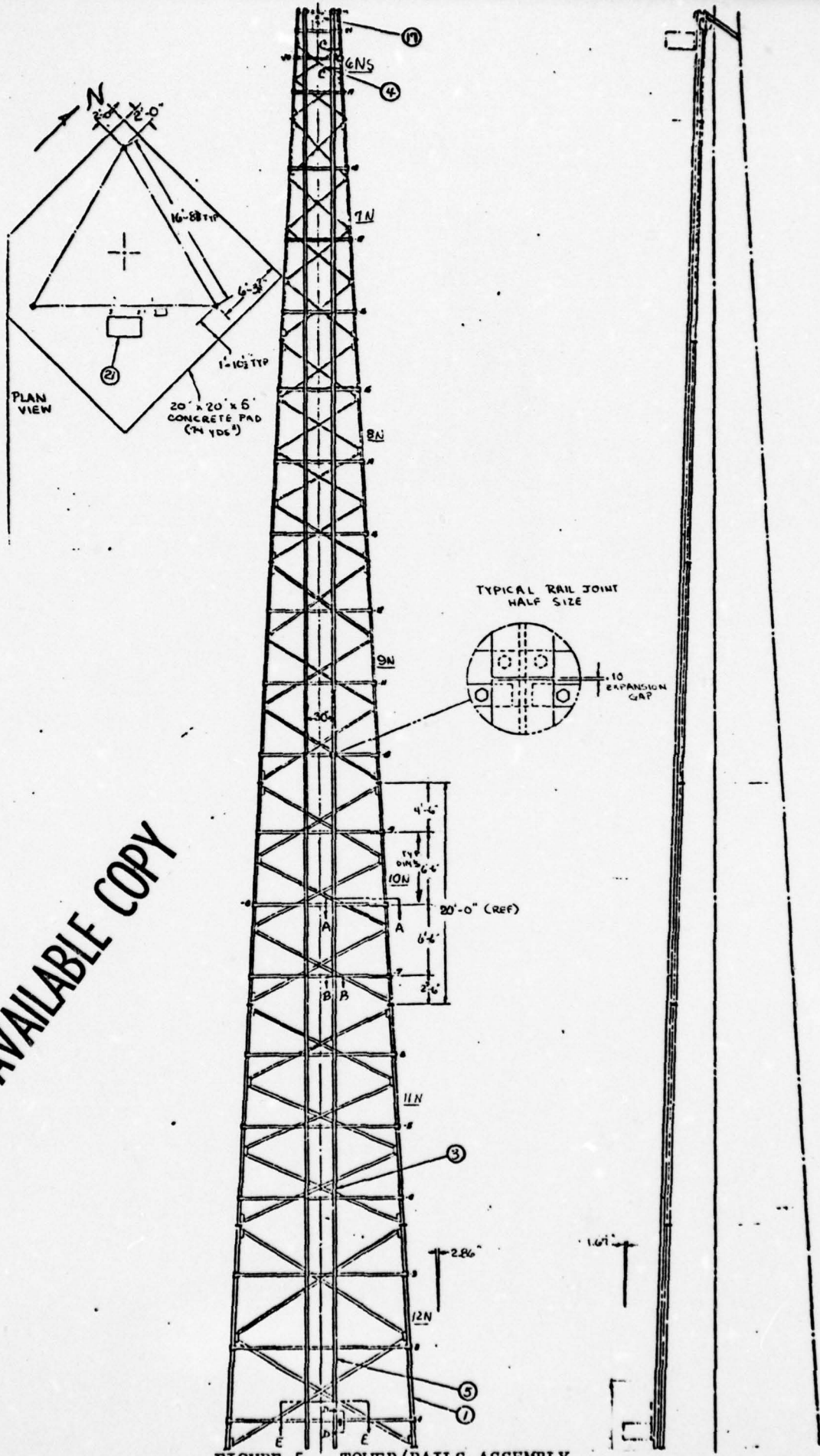
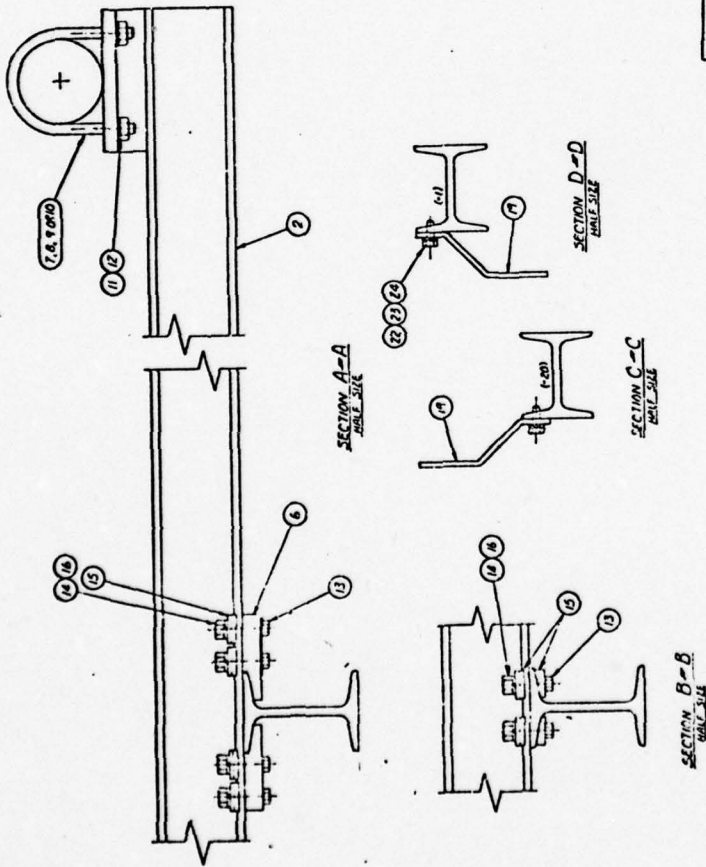

FIGURE 5. TOWER/RAILS ASSEMBLY

BEST AVAILABLE COPY

REFERENCE: TOWER FOUNDATION ASSEMBLY
 D-10045
 FROM DWG NOS E-410600, D-700300, SR-720300, B-631704



24	LOCK WASHER							
23	FLAT WASHER							
22	HEX HEAD BOLT	F 7516						
21	CHMT ASSEMBLY							
20	BRACKET - CHMT STOP	B-10132						
19	PULLEY ASSEMBLY	D-10135						
18	LOCK WASHER							
17	LEVEL WASHER							
16	HEX NUT							
15	HEX HEAD BOLT	F 7510						
14	FLAT WASHER							
13	FLAT WASHER							
12	HEX NUT							
11	HEX HEAD BOLT	F 7510						
10	FLAT WASHER							
9	HEX NUT							
8	HEX HEAD BOLT	F 7510						
7	FLAT WASHER							
6	FLAT WASHER							
5	CLEARANCE							
4	CLEARANCE							
3	CLEARANCE							
2	CLEARANCE							
1	CLEARANCE							

Figure 6. Tower/Rails Assembly Detail

PLATE TABULATION:
MIL: 1/2 IN. 6061-T6 ALUM. BAR

PLATE LETTER	W	D	T	W	D	T
W	3.89	.713	5.50	6		
X	3.59	.721	5.50	6		
Y	2.89	.744	4.50	10		
Z	2.39	.721	4.00	14		

SPRINGER TABULATION:
MIL: 6061-T6 ALUM. BAR

SPRINGER LETTER	W	D	T	W	D	T
A	3.50	.700	6			
B	5.00	.725	2			
C	5.00	.700	3			
D	5.00	.75	3			
E	4.50	.700	2			
F	4.50	.75	3			
G	4.50	.75	3			
H	4.50	.75	3			
I	4.00	.75	3			

- MATERIAL LIST:
- 3" I-BEAM - 10 PCS, 25' LONG
 - 1/2" x 6" BAR - 1 PC, 20' LONG
 - 1/2" x 6" BAR - 1 PC, 6' LONG
 - 1/2" x 6" BAR - 1 PC, 4' LONG
 - 1/2" x 6" BAR - 1 PC, 4' LONG
 - 1/2" x 6" BAR - 1 PC, 5' LONG
 - 1/2" x 6" BAR - 1 PC, 10' LONG

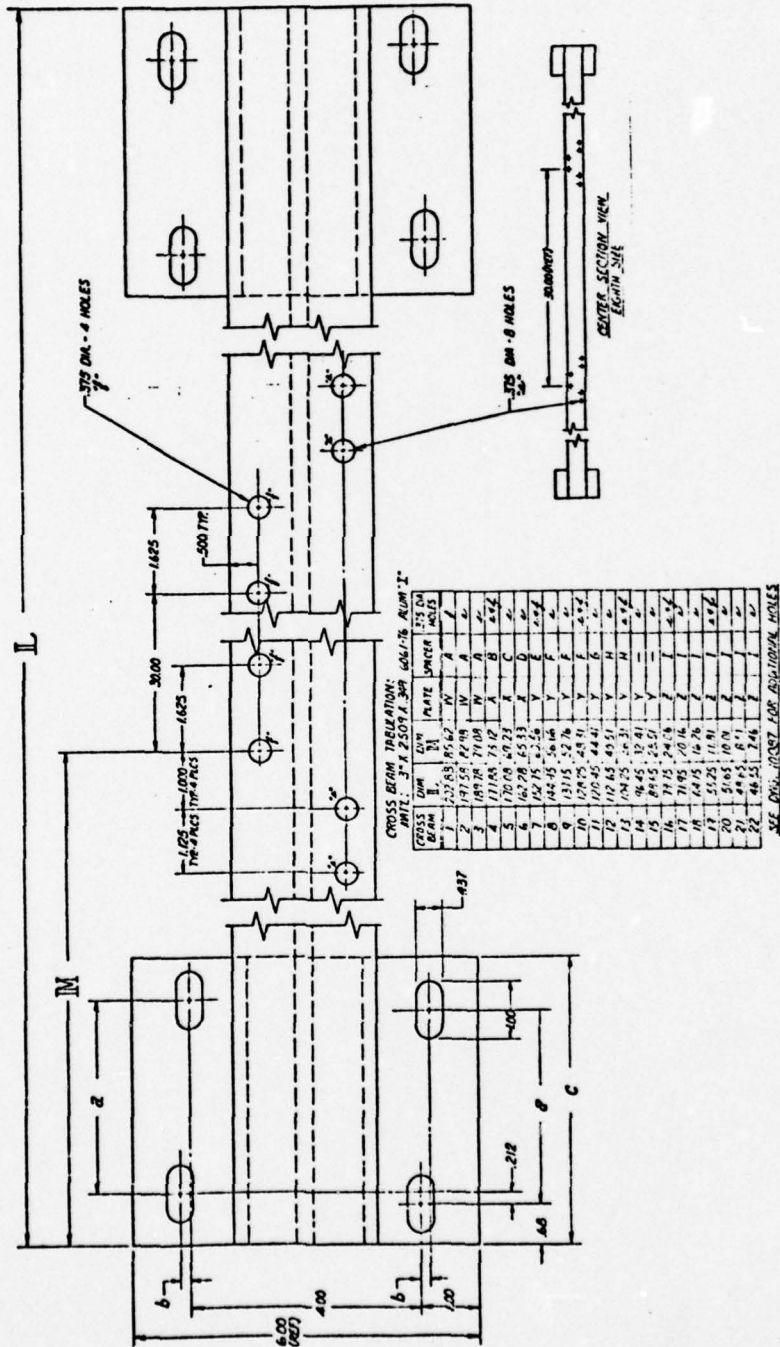

BEST AVAILABLE COPY

Figure 7. Cross Beams for Rails

The cross members were attached to the tower legs using U bolts, as shown in Figure 6. Flanges were welded to the cross members (Figure 7) to permit attachment using U bolts. Note that the flanges were necessary to permit the cross members to clear the angled X bracing used in the tower. The rails were installed at a spacing of 30 inches (Figure 5). Rail sections were 20 feet long (Figure 8), with the exception of the top and bottom sections (Figures 9 and 10, respectively). The base of each rail was bolted to an appropriately placed cross member. Slide cleats, as shown in Figure 11, were utilized at intermediate and top cross members to provide for rail expansion and contraction. A typical track joint is shown in Figure 5.

PULLEY ASSEMBLY

A top pulley framework was also fabricated out of the aluminum I beams and attached to the tower legs and top track section. An overall view of the pulley assembly is shown in Figure 12; individual components are shown in Figures 13, 14, 15, 16, and 17. A 14" diameter pulley installed on a 1.5-inch diameter steel shaft was utilized for guiding and supporting the cart drive cable. A pulley guard was installed to retain the 3/8-inch diameter drive cable within the pulley. Such a guard was necessary to retain the drive cable during the tower erection process as the drive cable was installed with the tower horizontal on the ground.

TOWER ERECTION

Once the tower, track, and pulley mechanism had been installed the tower was ready for erection. It was tilted and lifted into position onto the anchor bolts which had been positioned when the concrete pad was poured. With the use of leveling nuts the tower was plumbed and then locked into position by retaining nuts.

That same day the tower beacon was connected to electric power and made operational. Also the lightning protection, track, and each tower leg were hooked to the grounding ring.

BEST AVAILABLE COPY

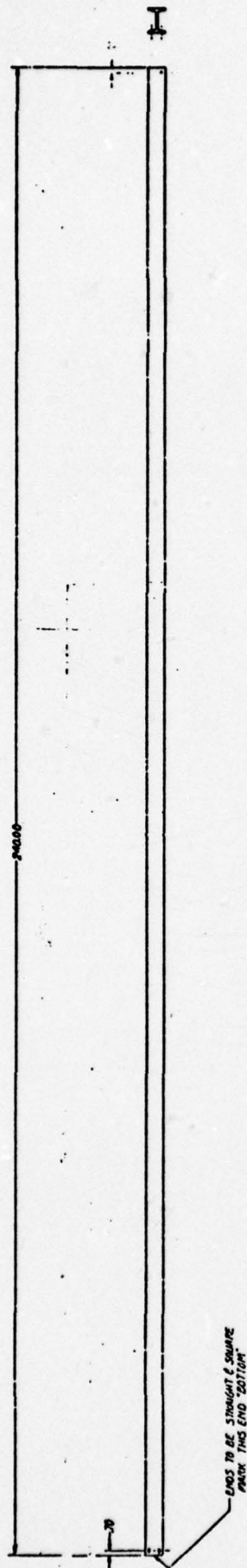

14

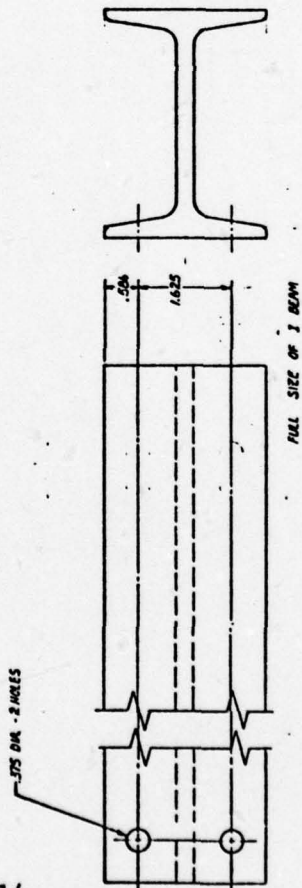

Figure 8. Weather Tower Rail Detail

BEST AVAILABLE COPY

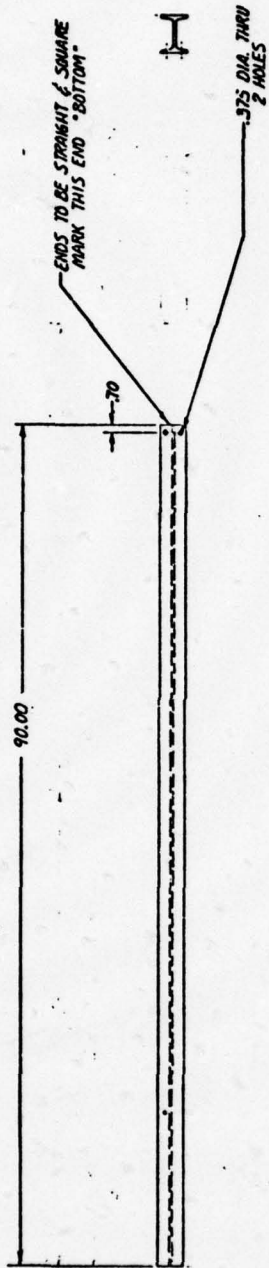

Figure 9. Rail (Top Section)

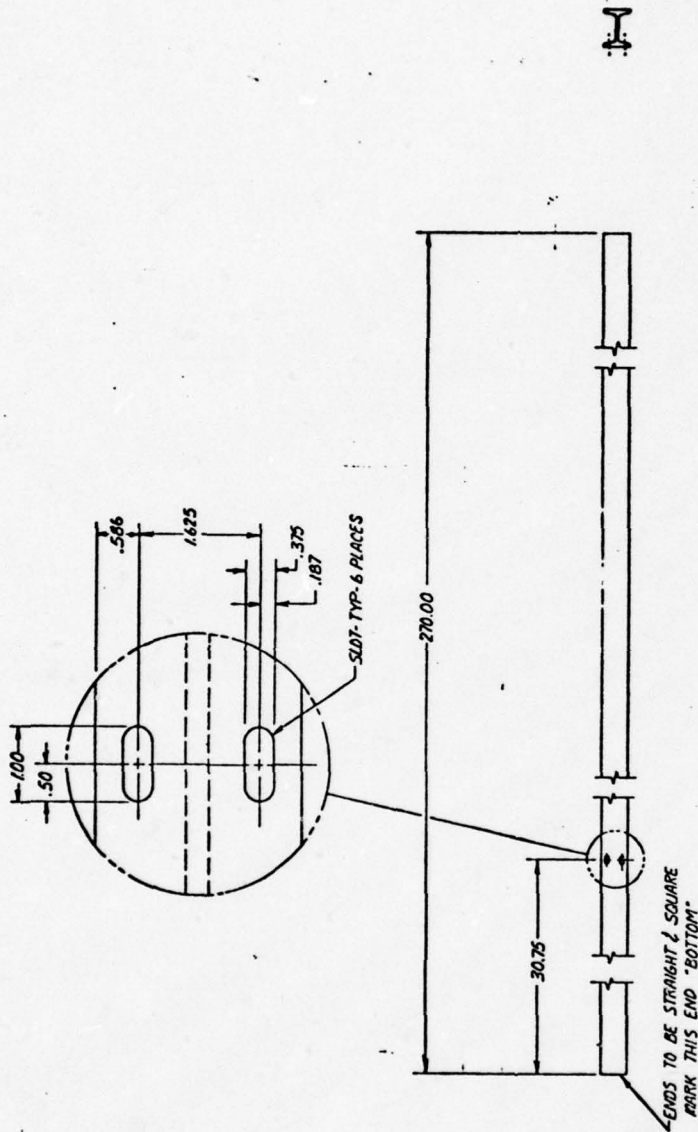

Figure 10. Rail (Bottom Section)

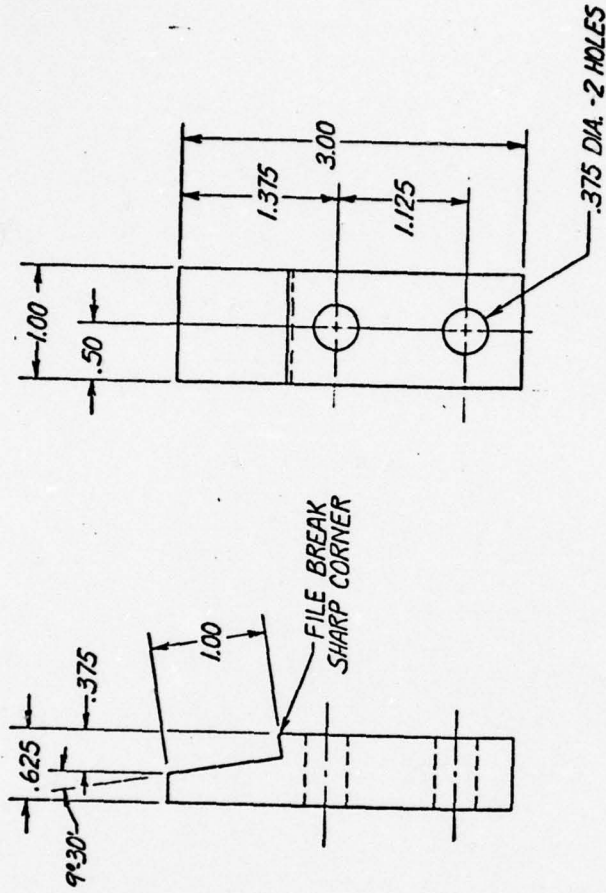

Figure 11. Rail Cleat

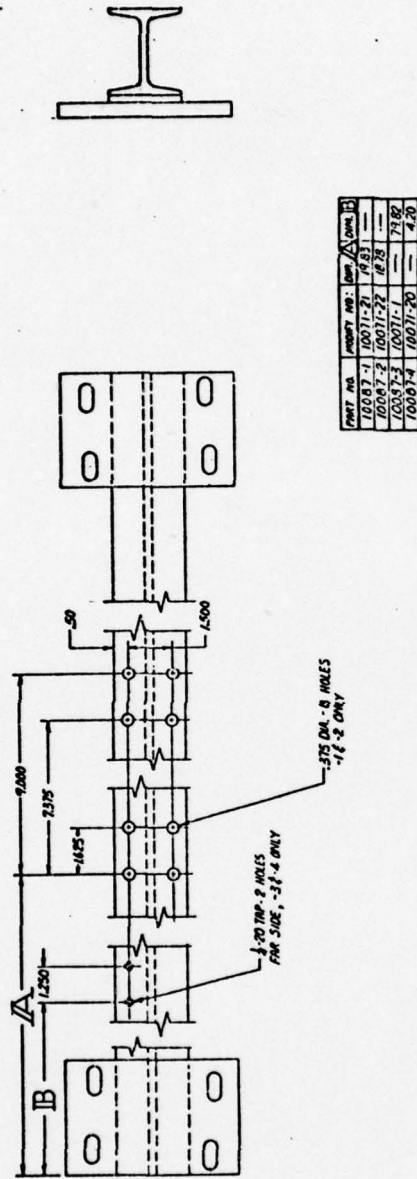

Figure 13. Cross Brace Modification

BEST AVAILABLE COPY

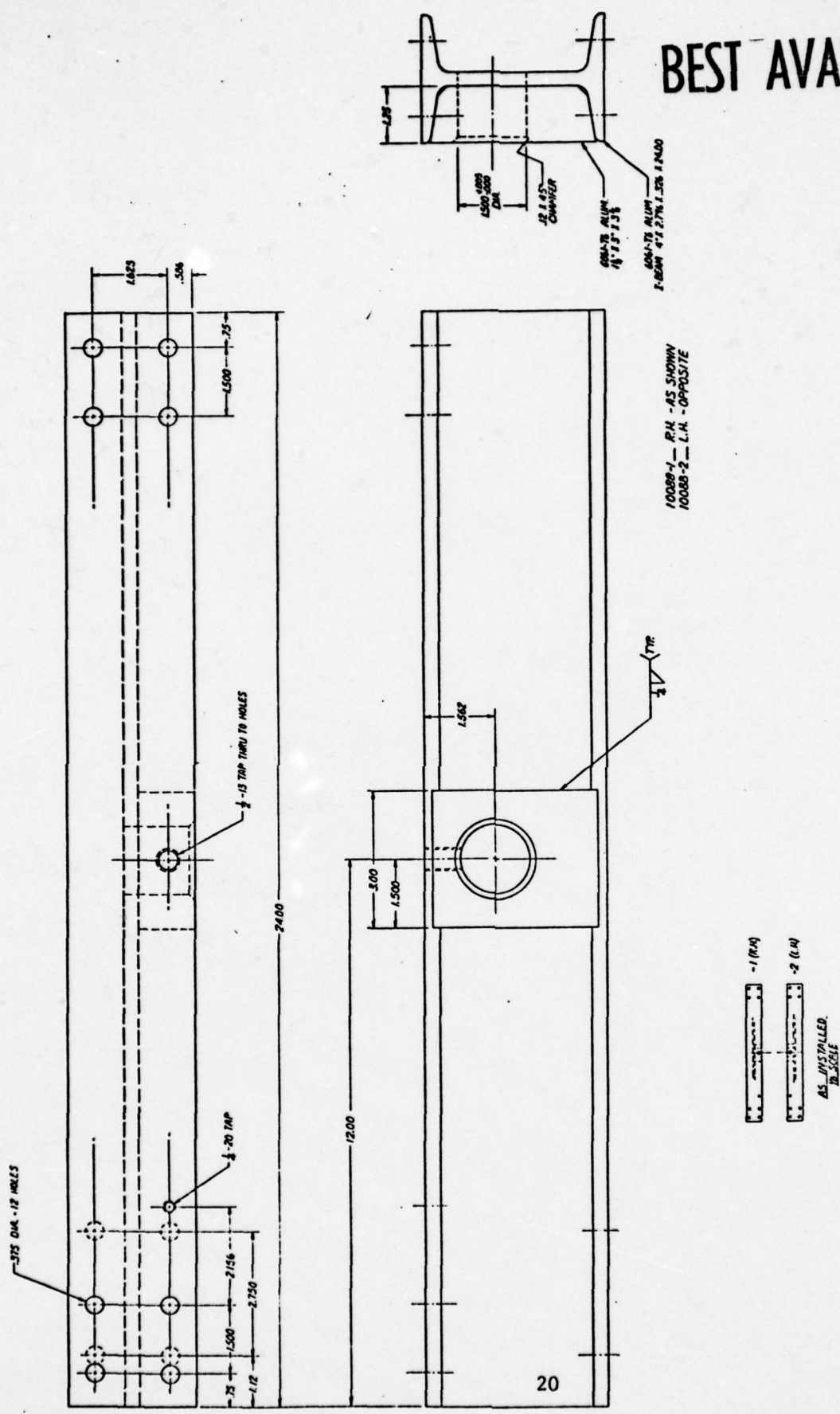

Figure 14. Pulley Support, Rails (Right Hand and Left Hand)

BEST AVAILABLE COPY

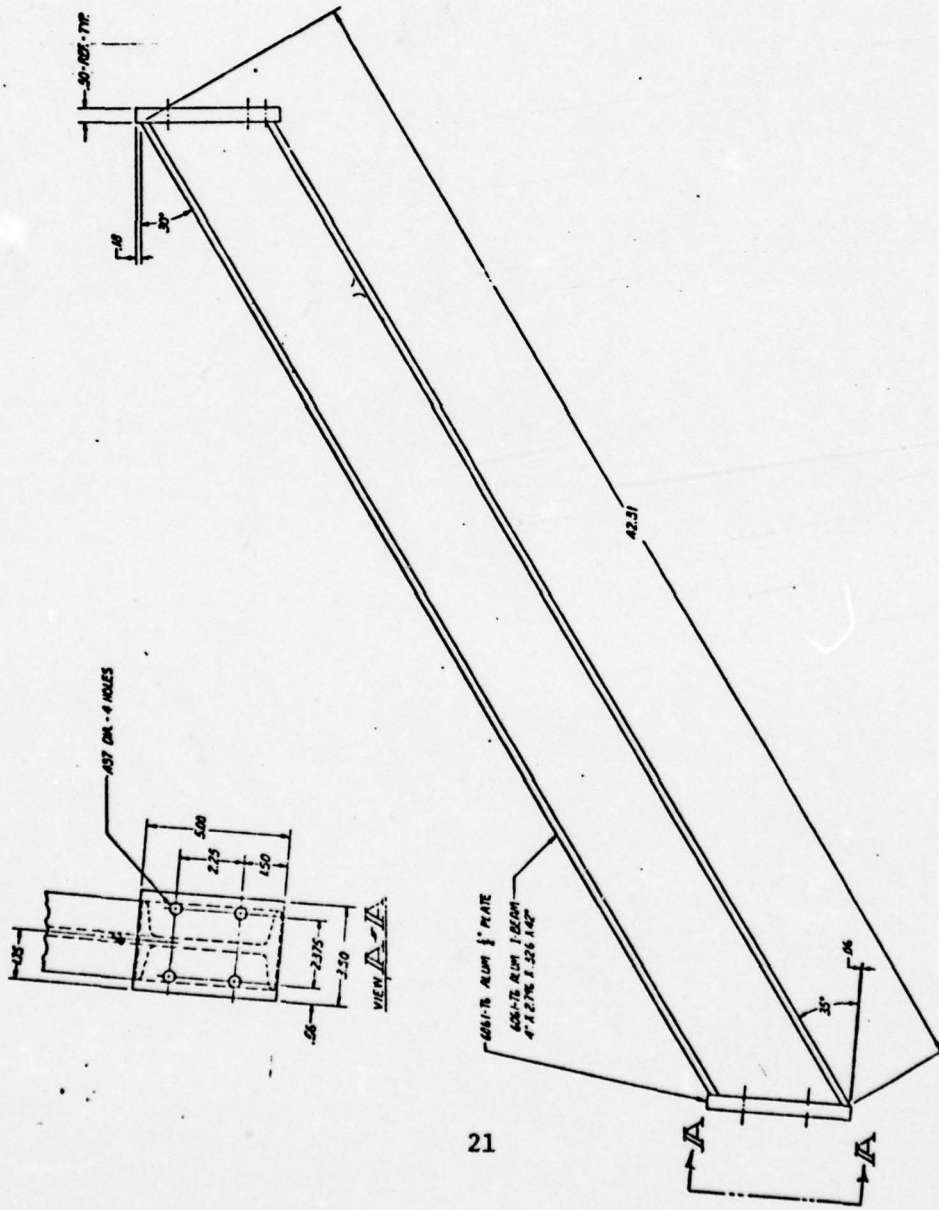
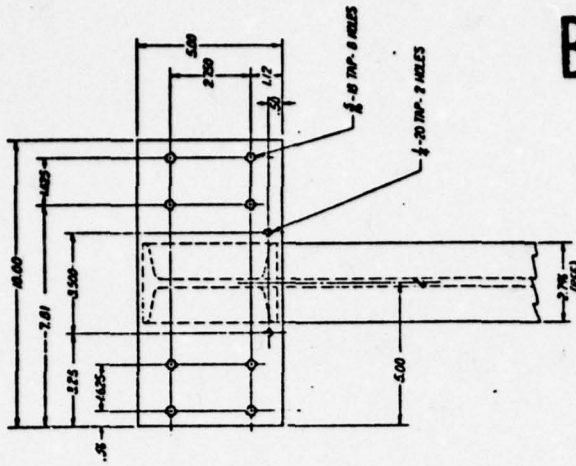

Figure 15. Pulley Support Brace

BEST AVAILABLE COPY

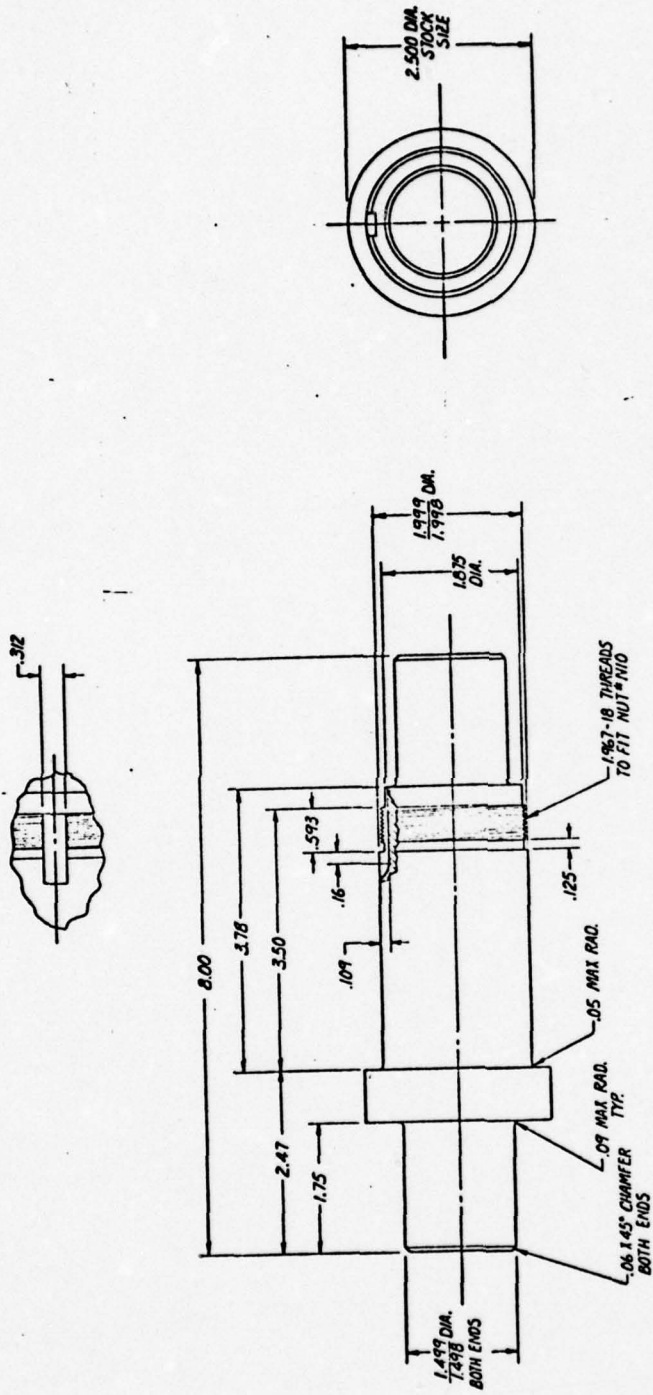

Figure 16. Pulley Shaft

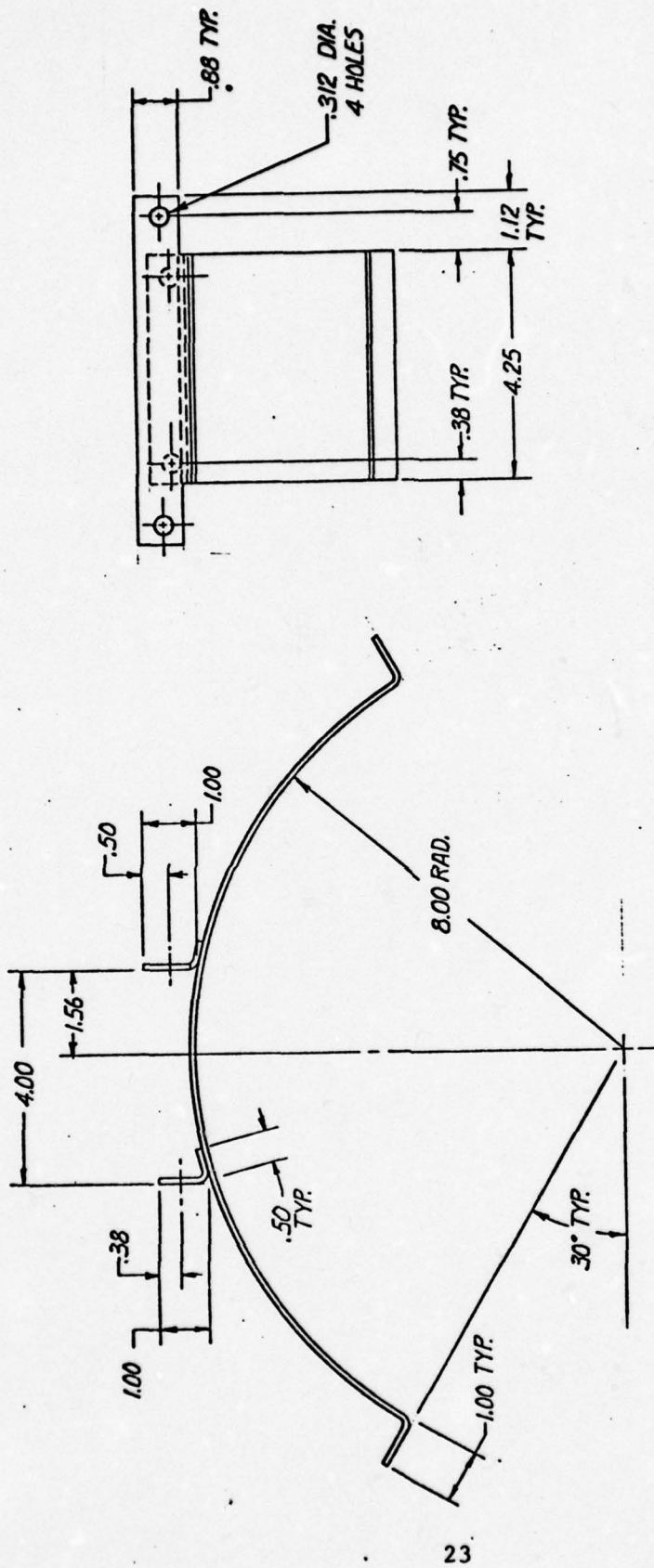

Figure 17. Pulley Guard

SECTION VI
CART ASSEMBLY

CART DRIVE

The cart upon which the instrumentation package is mounted is driven by a winch drive and cable arrangement. The drive cable is wrapped several times around a drum at the tower base, passed over the pulley at the top of the tower, and its ends attached to the cart.

The winch assembly is shown in Figures 18, 19, and 20. Winch power is supplied by a 2 horsepower reversible motor which is connected to a 300:1 gear reducer through a Flexidyne coupling. The Flexidyne coupling is a dry fluid drive which provides a period of slippage between the motor and load before the two become locked together and achieve full load speed. By this means the motor accelerates quickly with greatly reduced loading and starts the instrument package smoothly. The coupling also acts as a torque limiter in that it slips if a preset maximum torque is exceeded.

The 300:1 gear reducer acts as a torque amplifier to provide sufficient torque to operate the cart. The output of the reducer is connected through a chain coupling to the winch drum. The drum rotates at a speed of approximately 6 r/min, which translates to a cart speed of approximately 28.3 feet/minute. Thus the cart takes approximately 5 minutes to travel to the top of the tower.

The entire winch assembly is mounted on a steel base (Figure 21) which is bolted to the concrete tower pad. This assembly is covered by a plywood enclosure to protect it from the elements and has removable panels so that the entire mechanism can be serviced easily.

The winch motor is controlled by a "dead man" style hand-held control at the end of a 10-foot flexible cord. An emergency disconnect box is also provided near the operator. This emergency disconnect can be used during service of the winch mechanism or in the unlikely event of a failure in the hand-held control. The cart is automatically stopped at preset positions at

BEST AVAILABLE COPY

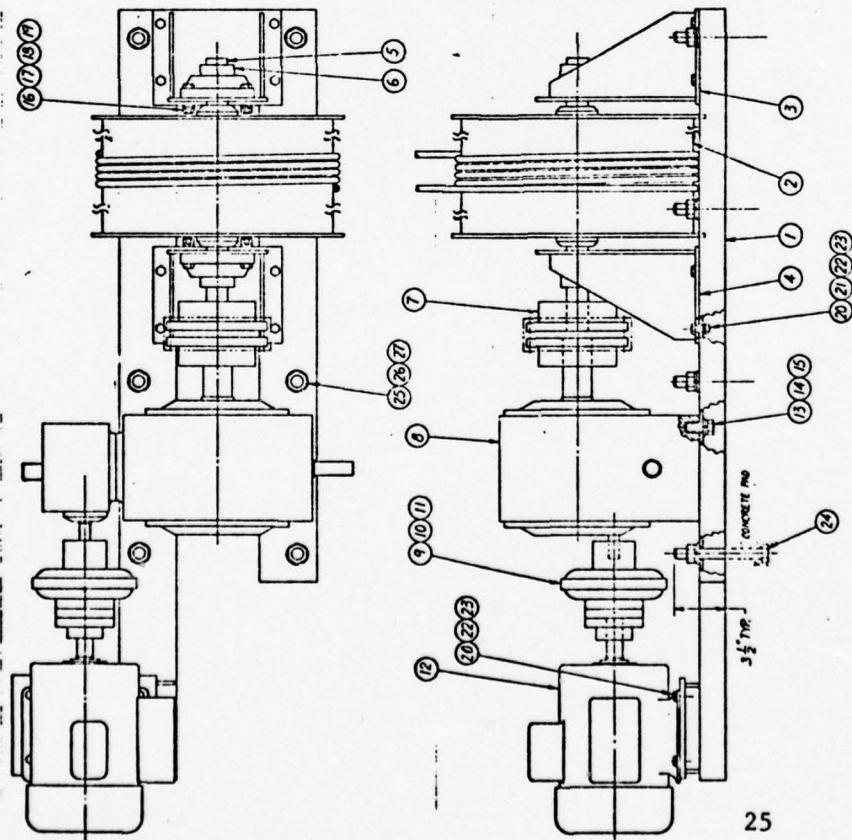

QTY	DESCRIPTION	UNIT	DATE	BY	CHKD	APP'D
6	FLAT WASHER - 3/4"					
6	LOCKWASHER - 3/4"					
6	HEX NUT - 3/4" X 1 1/2"					
6	HEX NUT - 3/4" X 1 1/2" LONG					
12	FLAT WASHER - 3/4"					
12	LOCKWASHER - 3/4"					
21	HEX NUT - 3/4" X 1 1/2"					
21	HEX NUT - 3/4" X 1 1/2" LONG					
20	FLAT WASHER - 1/2"					
20	LOCKWASHER - 1/2"					
18	HEX NUT - 1/2" X 1 1/2"					
18	HEX NUT - 1/2" X 1 1/2" LONG					
16	FLAT WASHER - 3/4"					
16	LOCKWASHER - 3/4"					
12	HEX NUT - 3/4" X 1 1/2"					
12	HEX NUT - 3/4" X 1 1/2" LONG					
11	FLAT WASHER - 1/2"					
11	LOCKWASHER - 1/2"					
10	HEX NUT - 1/2" X 1 1/2"					
10	HEX NUT - 1/2" X 1 1/2" LONG					
9	FLAT WASHER - 1/2"					
9	LOCKWASHER - 1/2"					
7	HEX NUT - 1/2" X 1 1/2"					
7	HEX NUT - 1/2" X 1 1/2" LONG					
5	FLAT WASHER - 1/2"					
5	LOCKWASHER - 1/2"					
3	HEX NUT - 1/2" X 1 1/2"					
3	HEX NUT - 1/2" X 1 1/2" LONG					
1	FLAT WASHER - 1/2"					
1	LOCKWASHER - 1/2"					
1	HEX NUT - 1/2" X 1 1/2"					
1	HEX NUT - 1/2" X 1 1/2" LONG					

Figure 18. Winch Drive Assembly

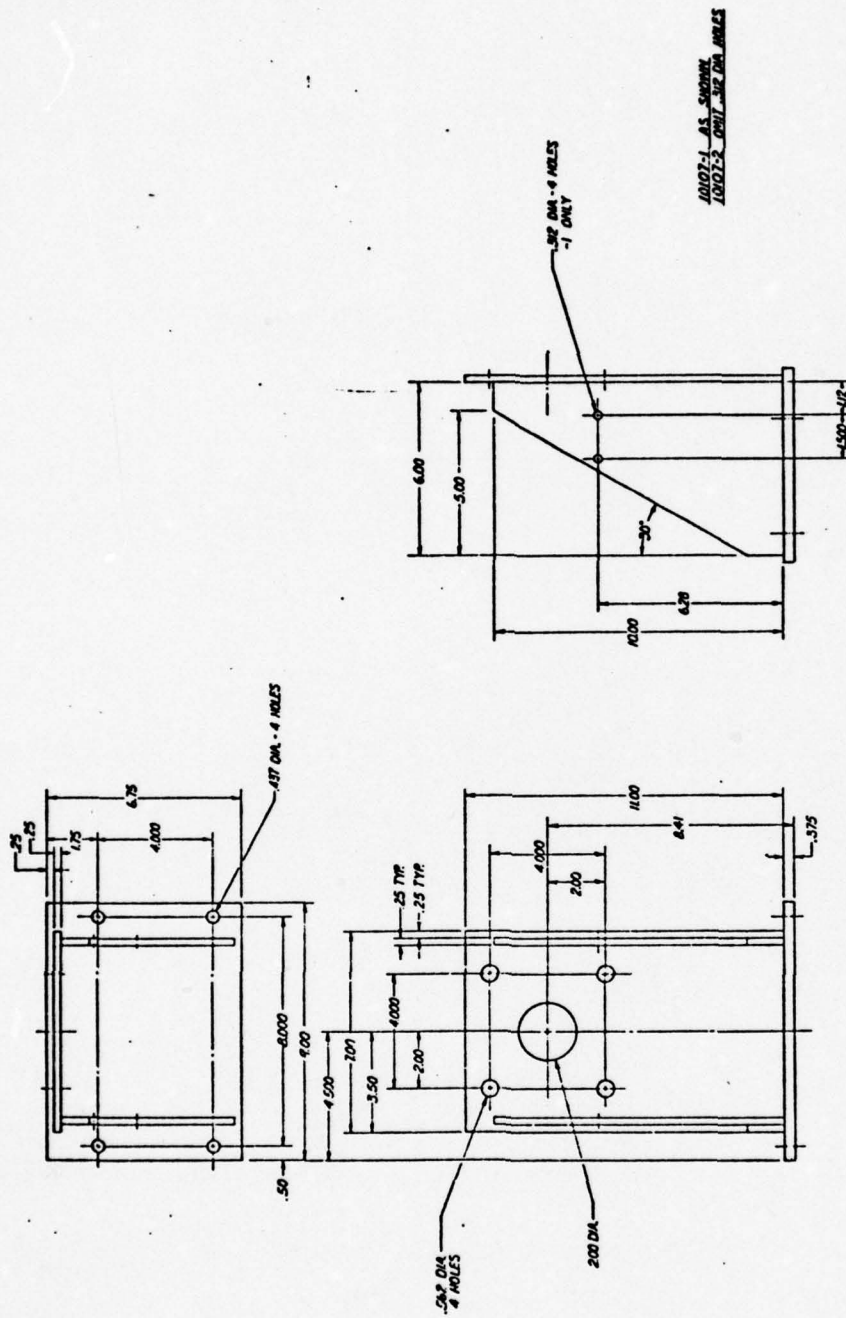

Figure 19. Winch Drum Bearing Bracket

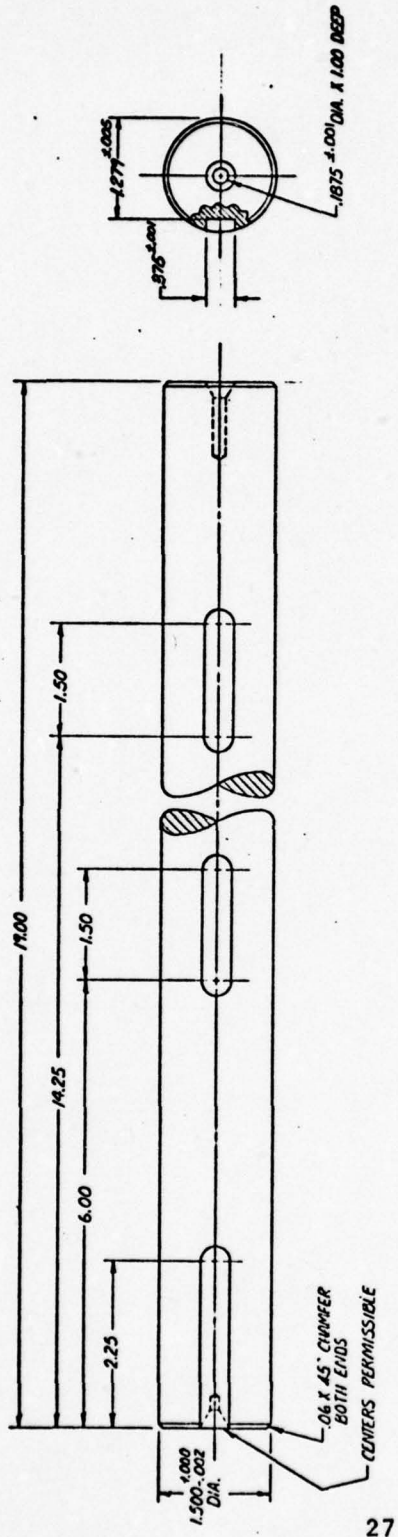

Figure 20. Winch Drum Shaft

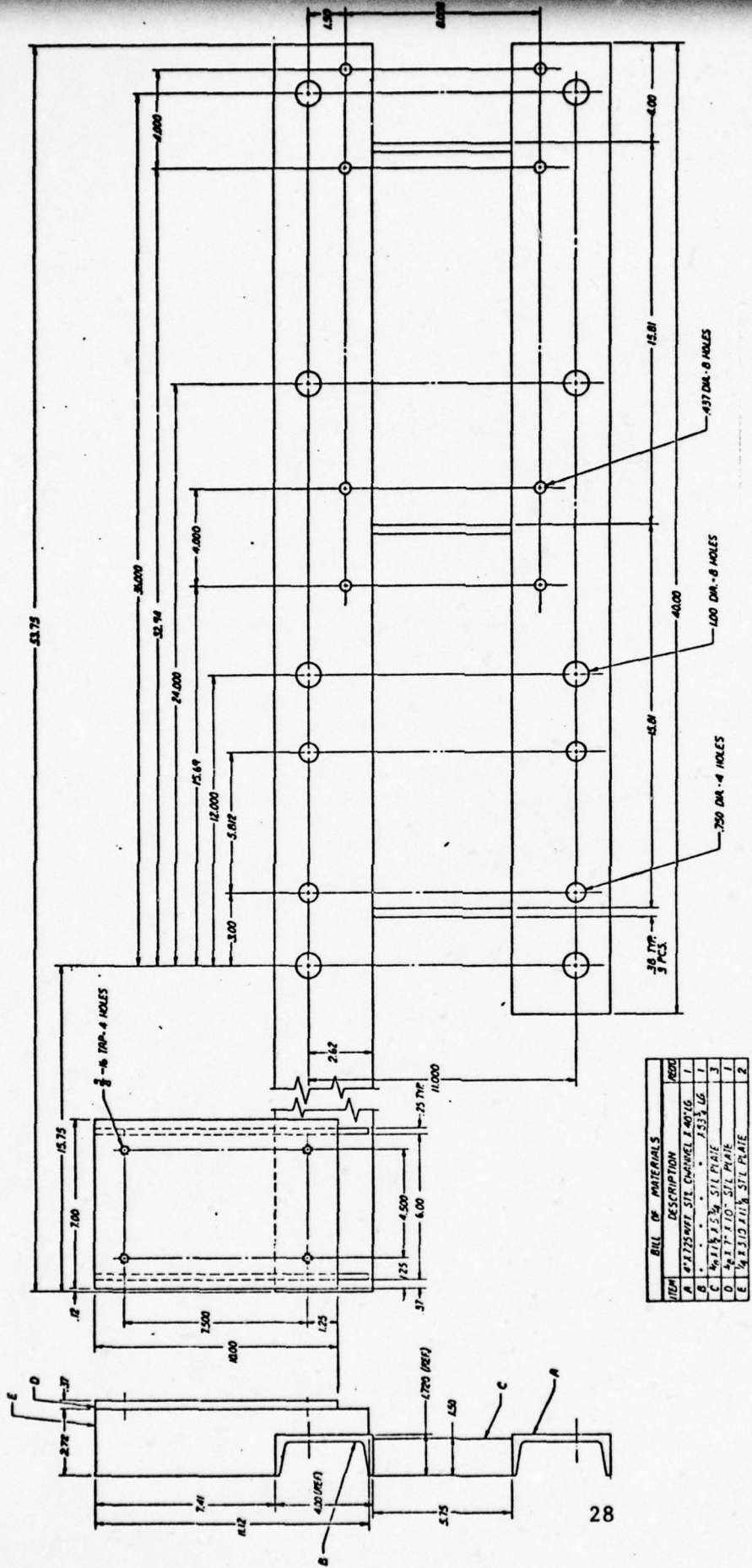

Figure 21. Power Winch Base

the top and bottom of the tower by microswitches mounted on the cart. The microswitches are mounted on the cart rather than the tower to facilitate service of the switch assembly. An electrically operated solenoid brake on the gear reducer provides a positive stop mechanism when the operator desires to stop the cart. A circuit diagram of this mechanism is shown in Figure 22.

INSTRUMENT CART

As has been indicated previously, a cart is utilized to transport the instrument package up and down the 130-foot tower. Views of the cart mounted on the track assembly are shown in Figures 23 and 24, while the basic cart frame is shown in Figure 25 and the drive cable attachment assembly in Figure 26. The cart is held on the track by a combination of side-, front-, and rear-mounted wheels (Figure 24). Four-inch (4-in.) diameter wheels ride the web of the I beams (bracket shown in Figure 27) and prevent sideways motion of the cart assembly. Rubber wheels 2-1/2 inches in diameter (brackets shown in Figure 28) ride against the inside and outside of the track flanges. Hard rubber was used on the top inner and lower outer wheels where the heaviest loading is, while soft rubber was used on the top outer and lower inner wheels to provide cushioning.

As shown in Figure 24, brakes were provided on the cart. The intent of these brakes is to restrain the cart in the unlikely event the drive cable should break. These spring-loaded brakes (Figures 29, 30, 31, and 32) are mounted on the same axle as the 4-inch diameter cart wheels, and when activated wedge the cart to the track.

The basic cart frame (Figure 25) was designed so that it can be quickly adapted to accept different instrument platforms. Figures 33 and 34 show the platform installed for initial tests. This platform is merely bolted onto the cart frame using an adaptor in the form of a steel angle. Using this procedure it is possible to build up a new instrument platform in the lab and install it without the need of removing the cart frame from the tower. Such a concept minimizes facility down-time when instrument packages are changed.

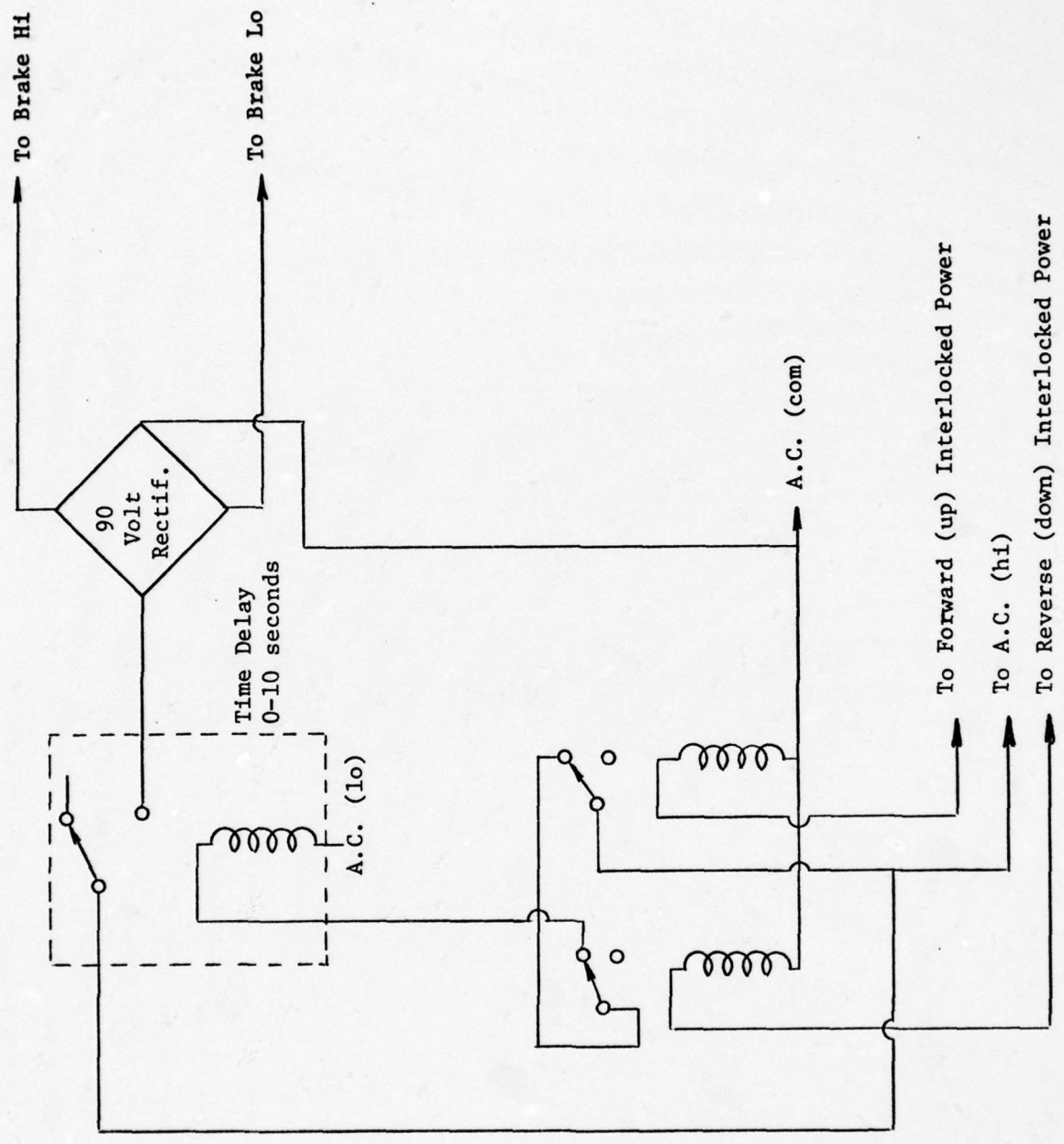

Figure 22. Brake Wiring

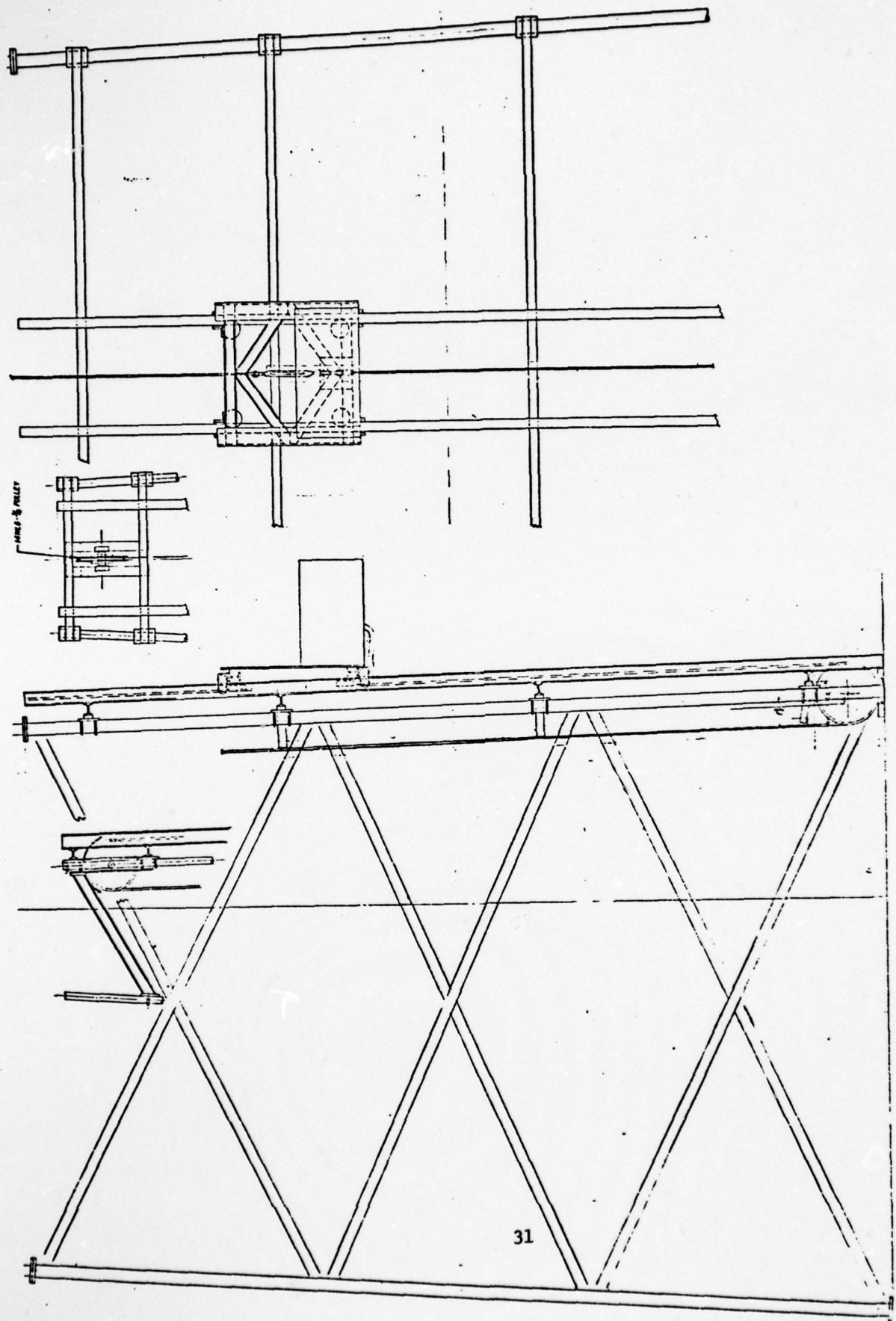

Figure 23. Cable and Pulleys

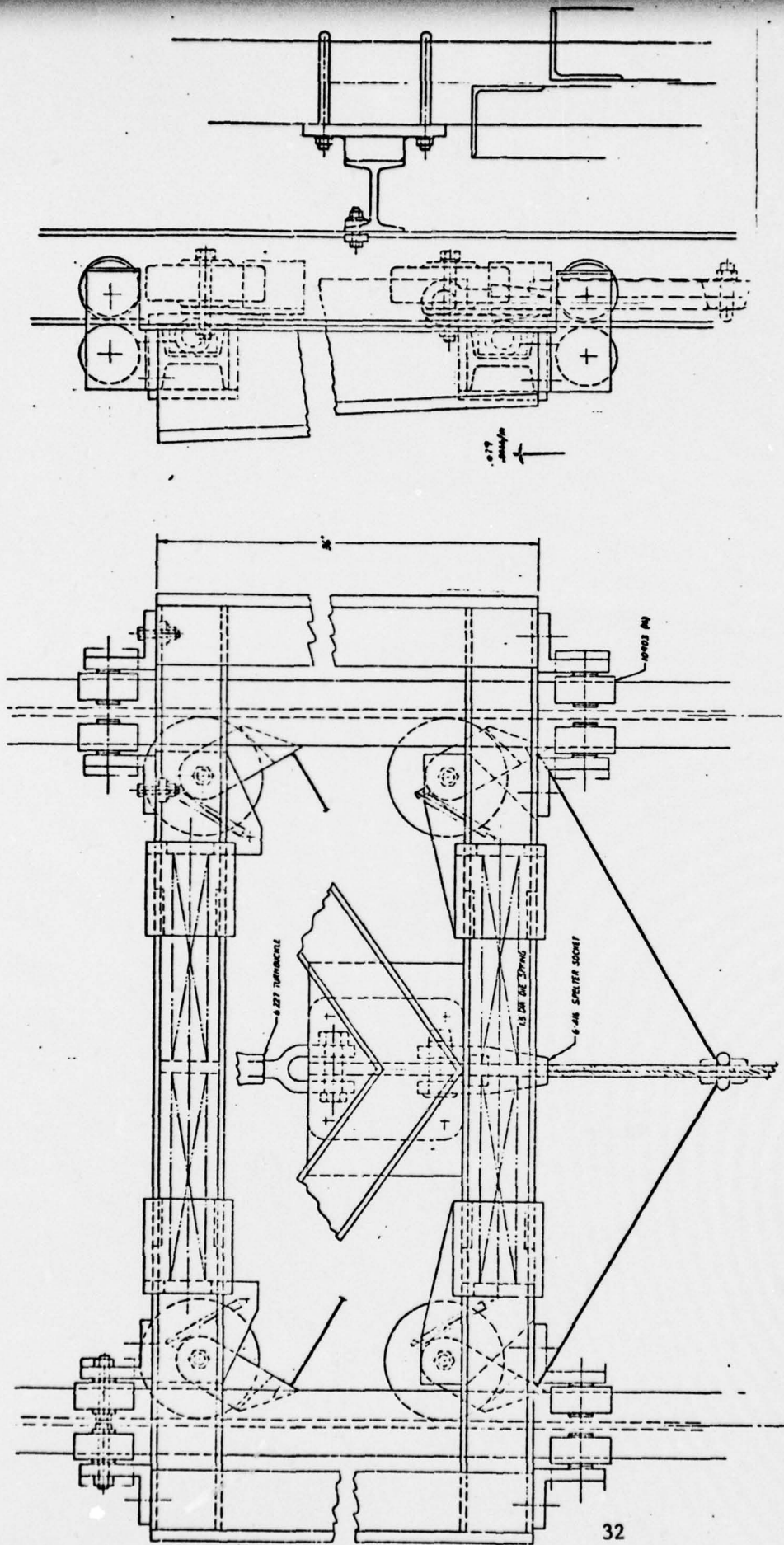

Figure 24. Cart Assembly Carriage

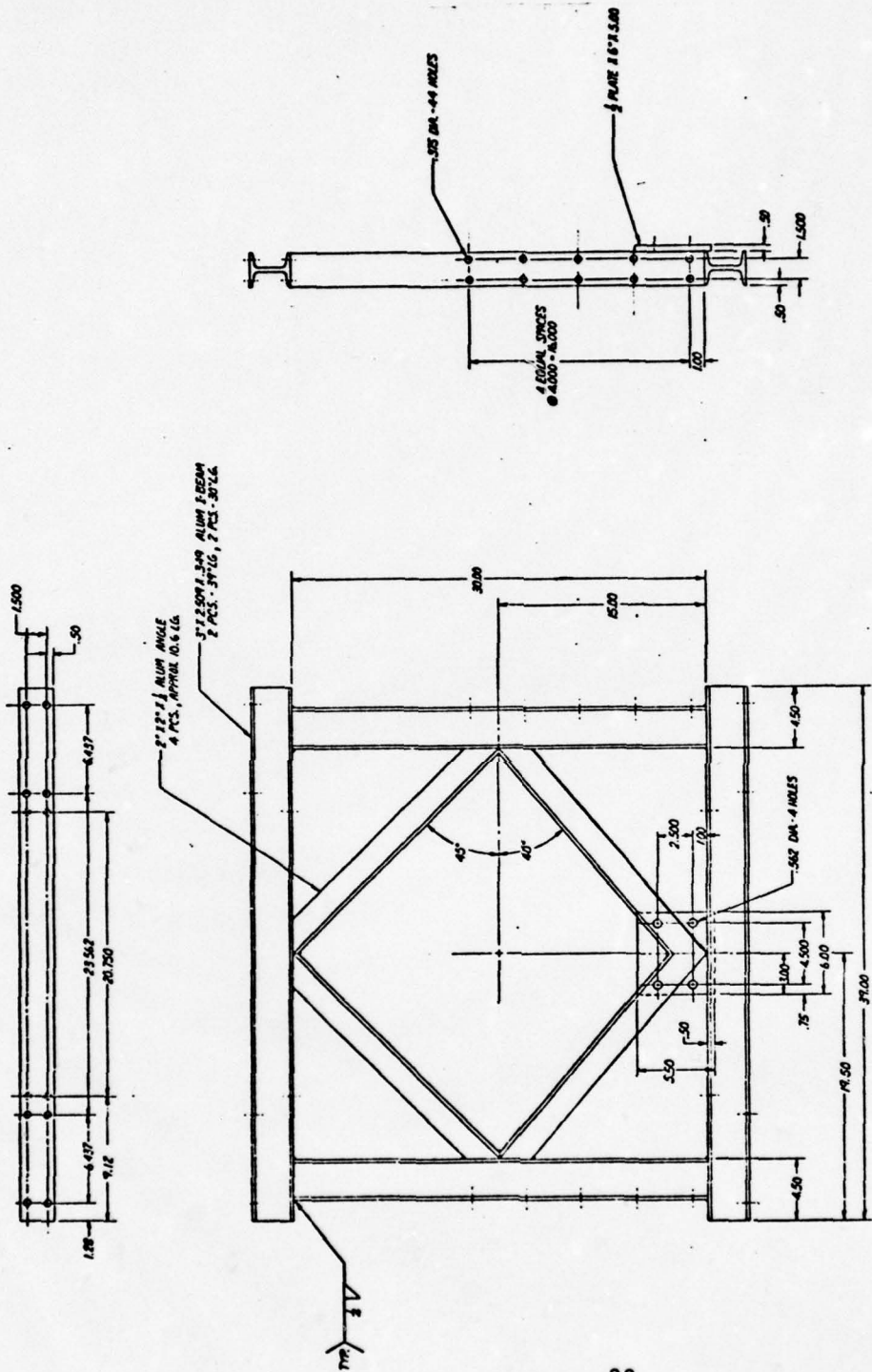

Figure 25. Carriage Frame

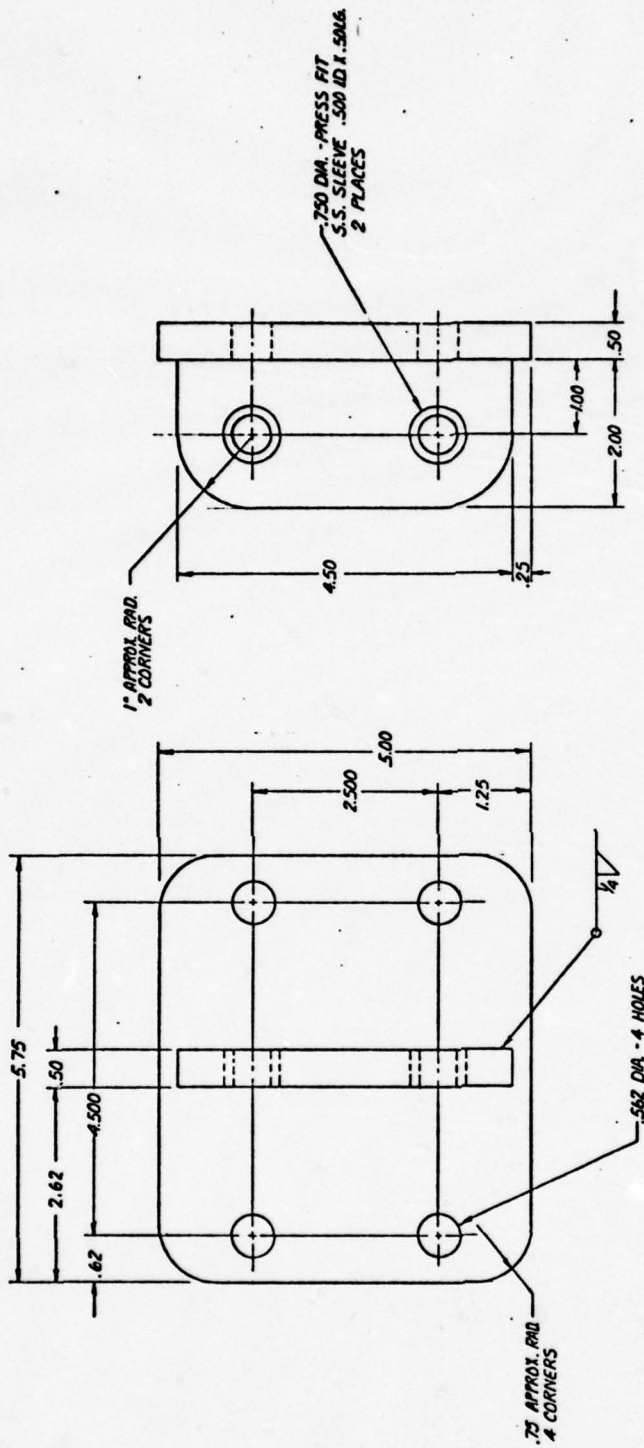

Figure 26. Cable Attachment Bracket

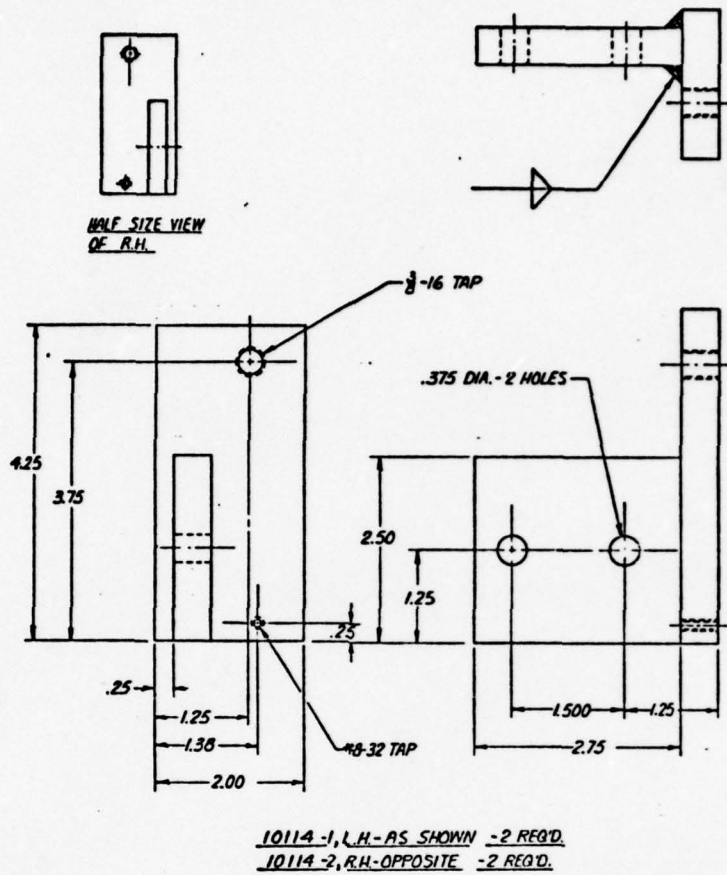

Figure 27. Wheel Bracket (4 inches)

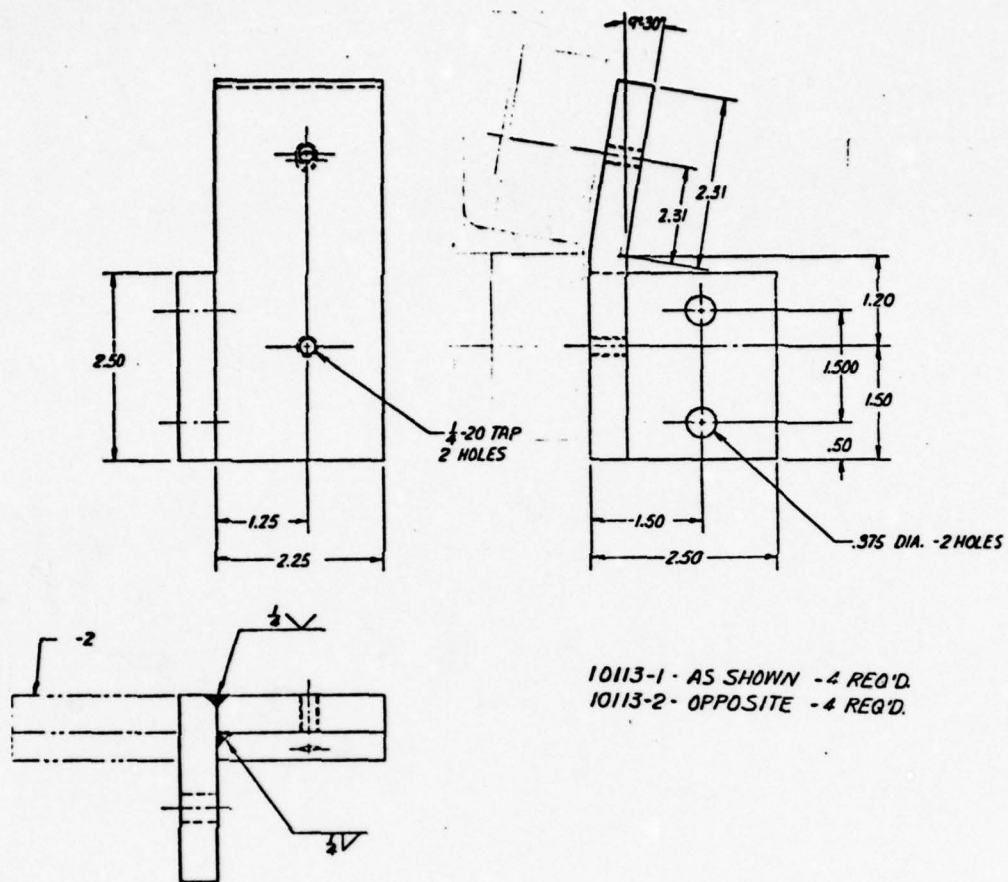

Figure 28. Wheel Bracket (2-1/2 inches)

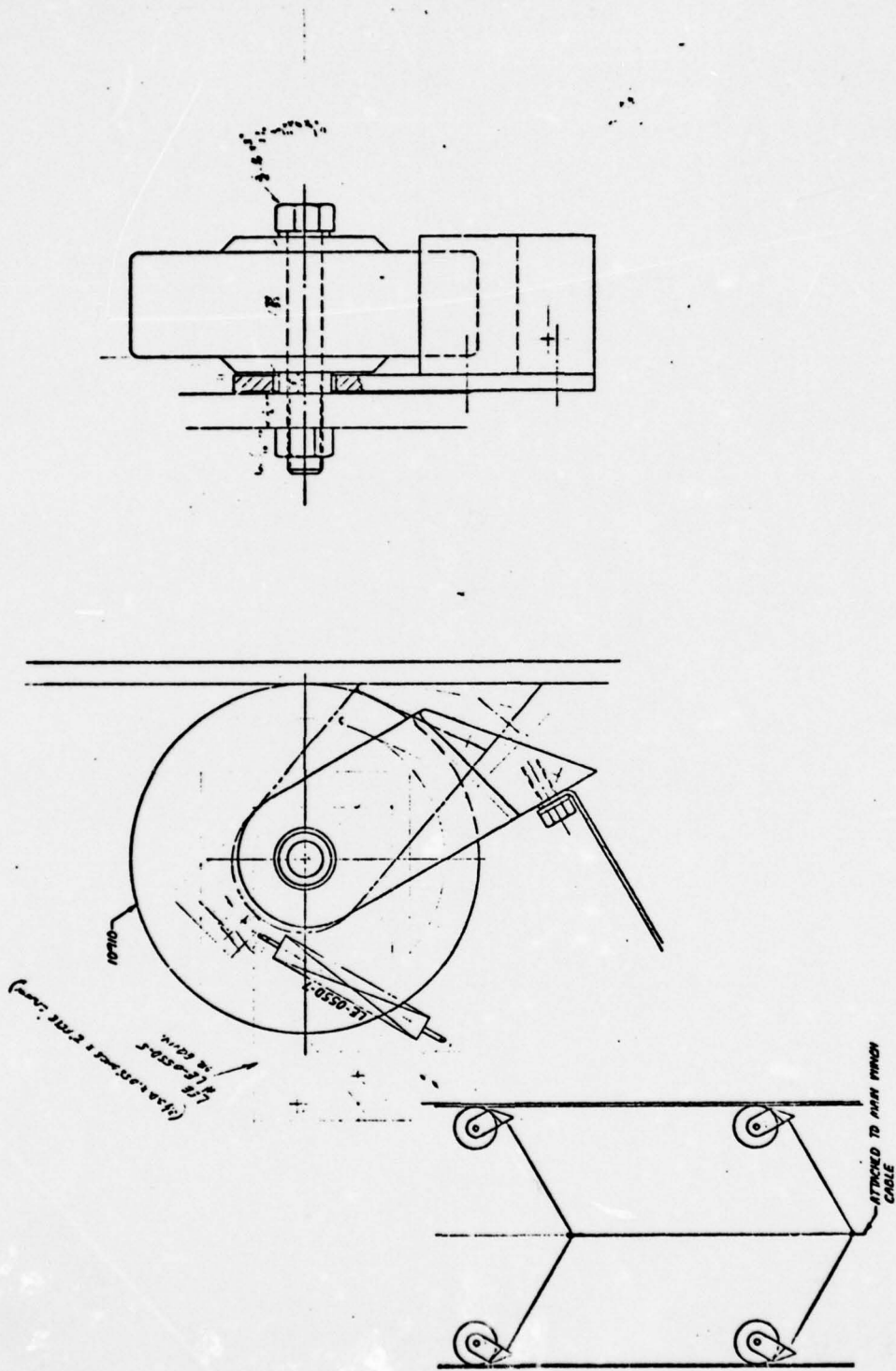
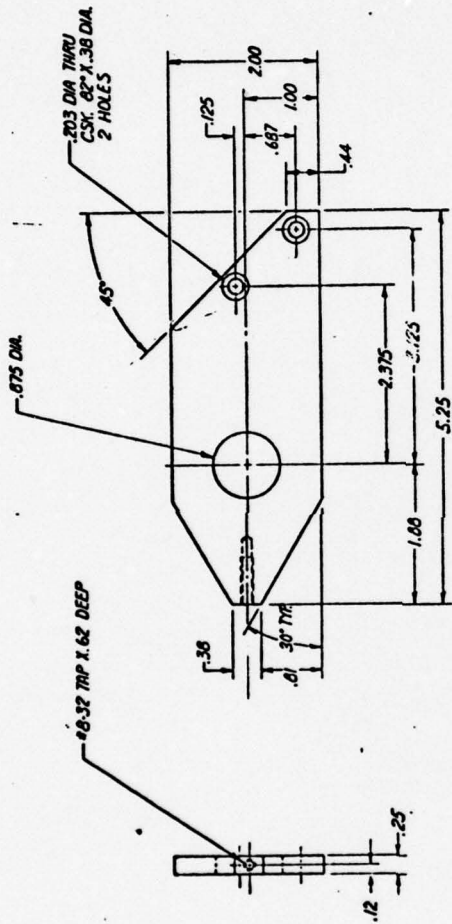

Figure 29. Safety Brake



Figure 31. Brake Arm Bushing



10115-1, R.H. - AS SHOWN - 2 REQD.
 10115-2, L.H. - OPPOSITE (CSK) - 2 REQD.

Figure 32. Brake Arm

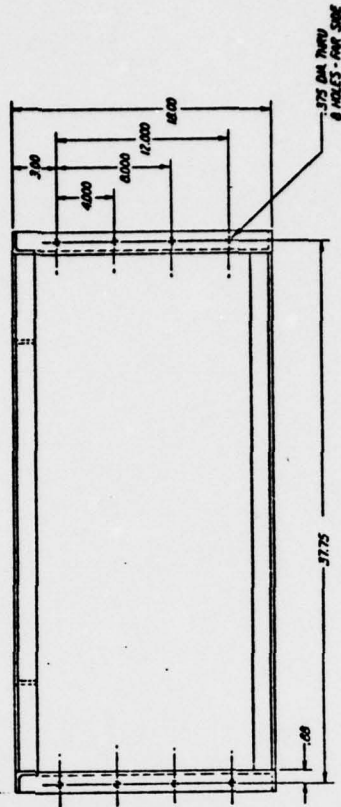
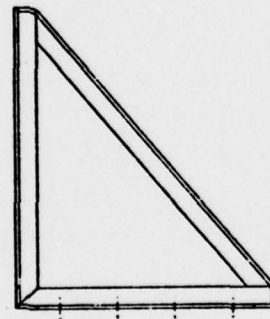
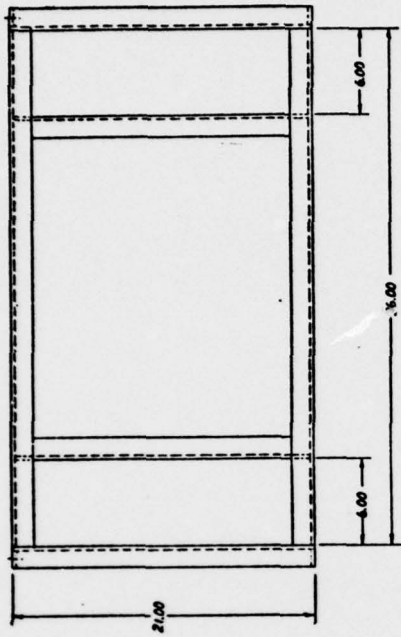
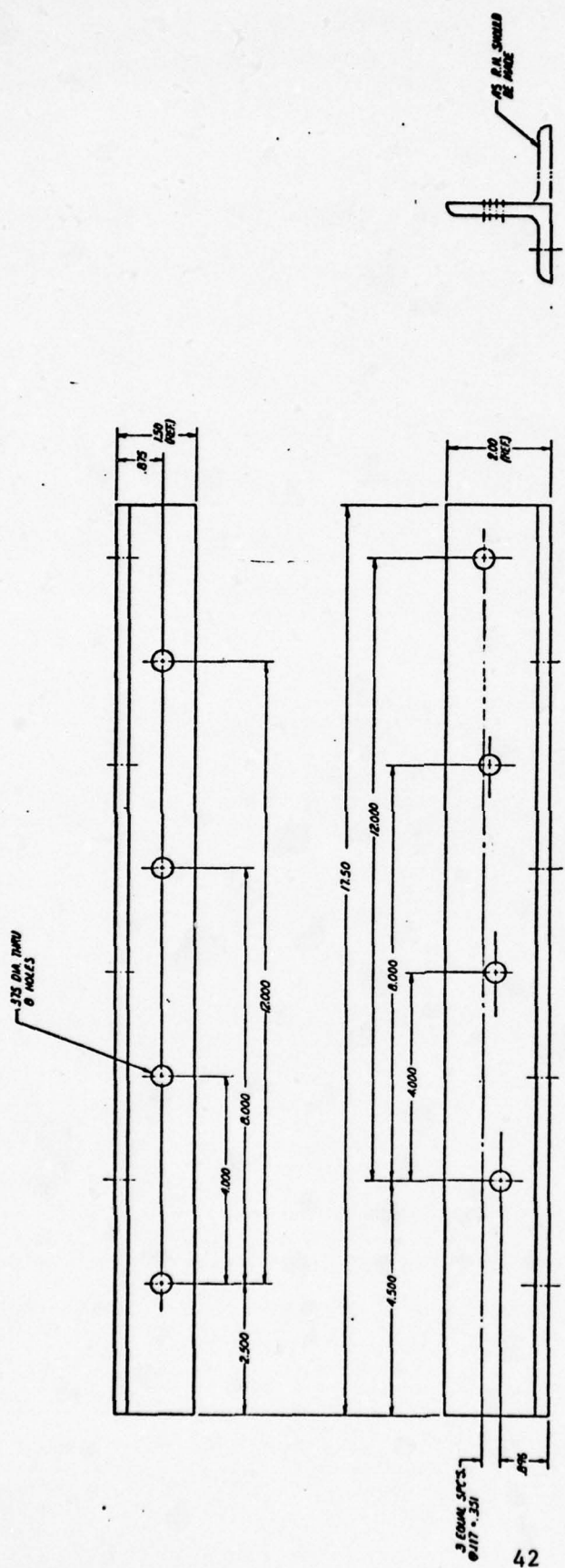

Figure 33. Instrument Cart Frame



10134-1 - L.H. AS SHOWN
 10134-2 - R.H. OPPOSITE

Figure 34. Instrument Cart Angle Brackets

SECTION VII INSTRUMENTATION PACKAGE

A temporary instrumentation package has been installed on the cart. Instruments installed and operating are temperature/dewpoint set, forward scatter meter, continuous reading pluviometer, barometer, wind speed and direction sensors, and a pyranometer.

A block diagram of the instrumentation presently installed on the instrumentation cart is shown in Figure 35. Control units for three of the instruments (temperature/dewpoint set, barometer, and forward scatter meter) were retained on the ground in the building at the tower base. This was done to reduce wind loading and also to maintain operator control of these instruments at a convenient location. The other instruments (pyranometer, pluviometer, and wind sensors) are self-contained, with no separate control units.

Connection between the tower installation and ground station was made by cables which are retained in the web of one of the rails by spring clips. The cables are guided into and out of the rail web by guides mounted on the cart. A 3-wire, 12-gauge cable feeds a.c. power up the tower. Instrumentation interface is handled by a cable containing 27 shielded pairs of wires.

Interface between the cable system and the tower and ground station is accomplished by distribution centers on the cart and within the building. These centers consist of terminal strips wired as shown in Figure 36. In addition each center has 3 a.c. power strips designated PTB-1, PTB-2, and PTB-3. Direct current power supplies are also contained in the cart center for those instruments requiring d.c. power. The cart distribution center is contained in a weatherproof enclosure with a hinged door, while the center in the building is mounted on the wall facing the cart.

The interfacing of the instruments to the cable system has been successfully accomplished as follows. The temperature/dewpoint set was split as shown in Figure 37. The only change made from normal installation is that

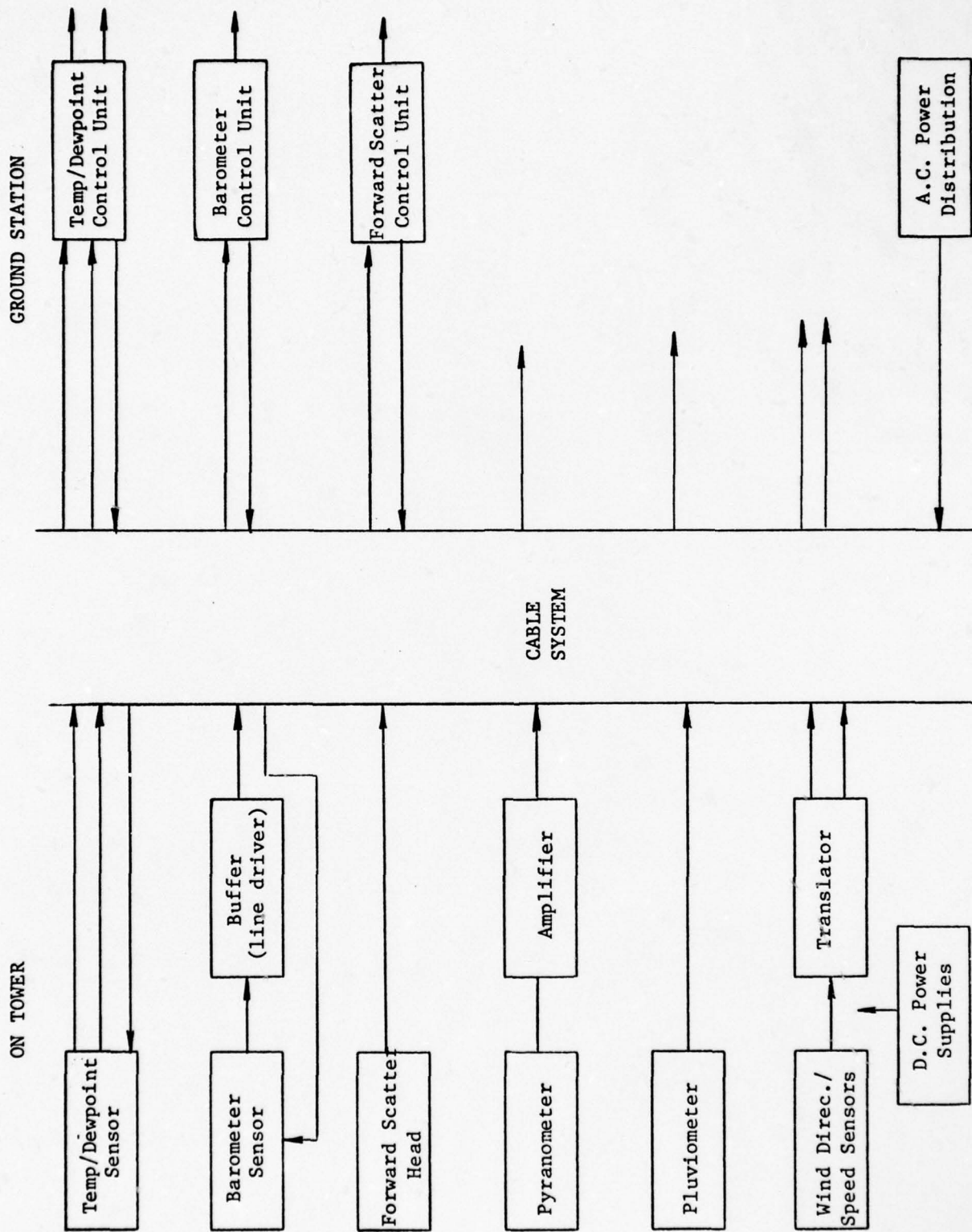

Figure 35. Block Diagram of 4-km Instrumentation

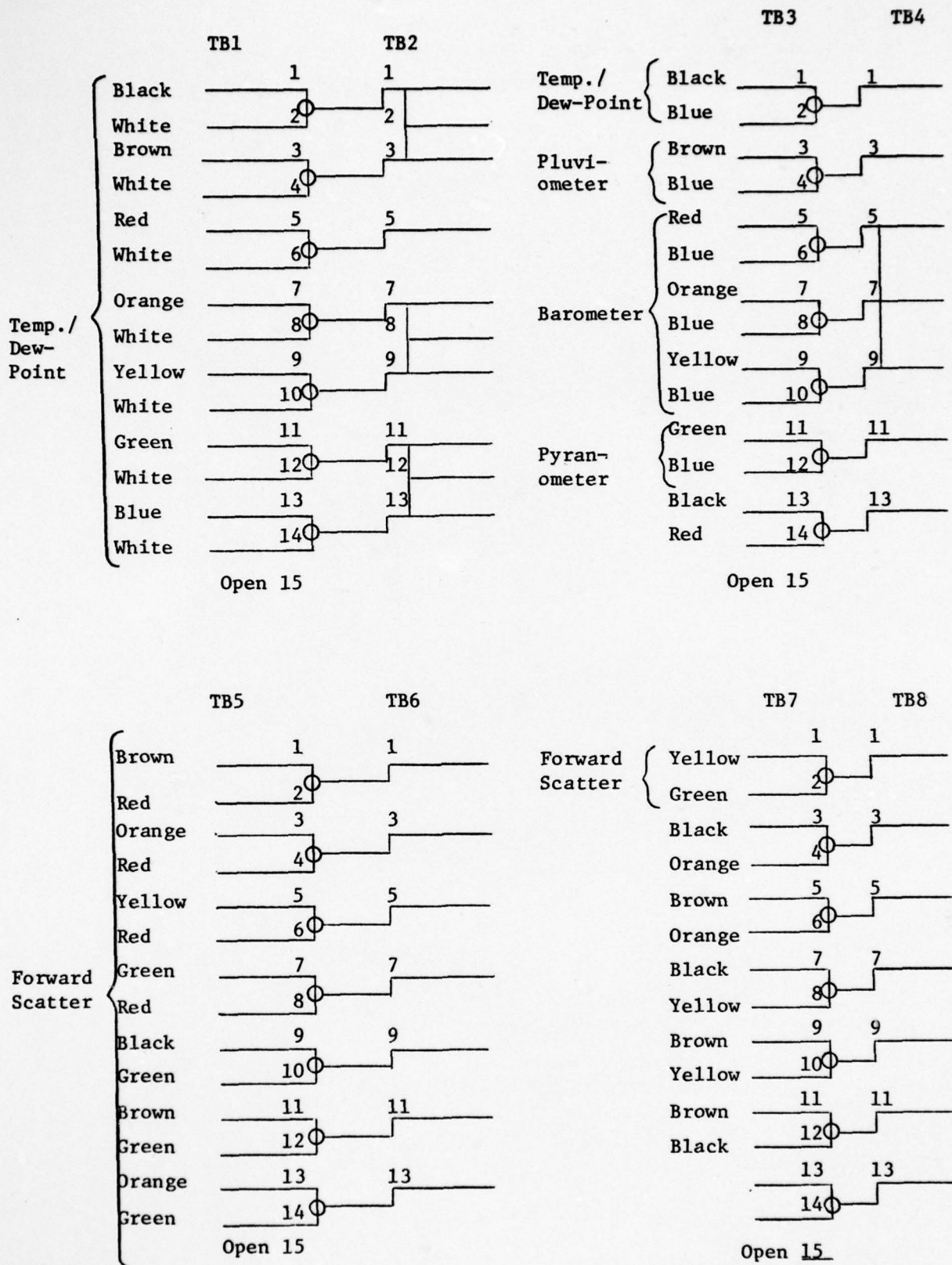

Figure 36. Distribution Center Wiring

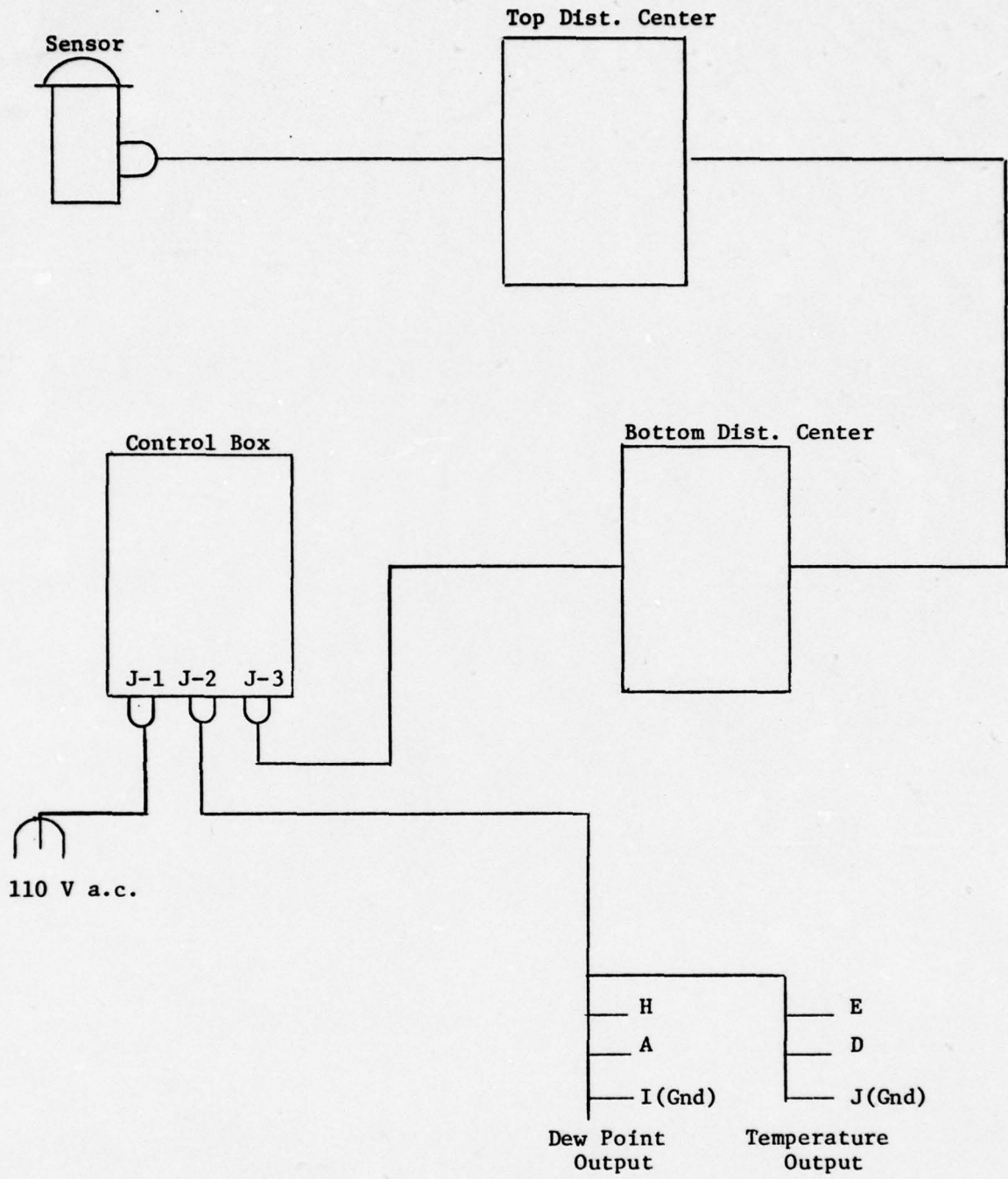

Figure 37. Temperature/Dewpoint Block Diagram

a.c. power is supplied to the sensor head from the PTB boards on the tower rather than carrying it up from the control unit. A complete wiring diagram is shown in Figure 38.

A demonstration barometer unit supplied by Hamilton Standard was initially installed. It consisted of a sensor enclosed in a clear plastic cylinder and a control unit in a portable case. The unit was interfaced to the cable system as shown in Figure 39. The line driver circuit was necessitated by the fact that the unit was not designed to operate with a 150-foot cable between the control unit and sensor. The sensor output is a TTL-compatible square wave whose frequency is proportional to barometric pressure (nominal frequency range 4.6 - 5.1 kHz). Before adding the line driver (a 74128) the signal deterioration at the base distribution panel was such that the control unit was not triggered reliably. The barometer unit has been removed from the instrument package, although the interface connections are still in place.

The pluviometer hook-up was straightforward as the unit is self-contained and requires only 115 volts input and outputs its signal on a two-wire cable. Figure 40 shows the interface of this unit to the cable system. Care was taken to mount the unit so that it suffers a minimum of shielding from other instruments.

The pyranometer is another instrument which is self-contained and requires a minimum of wiring to utilize its raw sensor output. However the sensor output is only 0 - 9 millivolts and it was necessary to amplify the signal for transmission through the tower cable. It was also desired to add a log amp circuit, which was done as shown in Figures 41 and 42. The log amp circuit and pyranometer were mounted on one arm of the forward scatter meter so that it has a "clear" view of the sun.

The wind set consists of a direction sensor and wind speed indicator. A translator is supplied with the units which converts the wind speed and direction signals to d.c. voltages which can then be used to drive a recorder, etc. Figure 43 shows the interface of the wind set translator to the tower cable system. As noted previously, the forward scatter meter has a separate

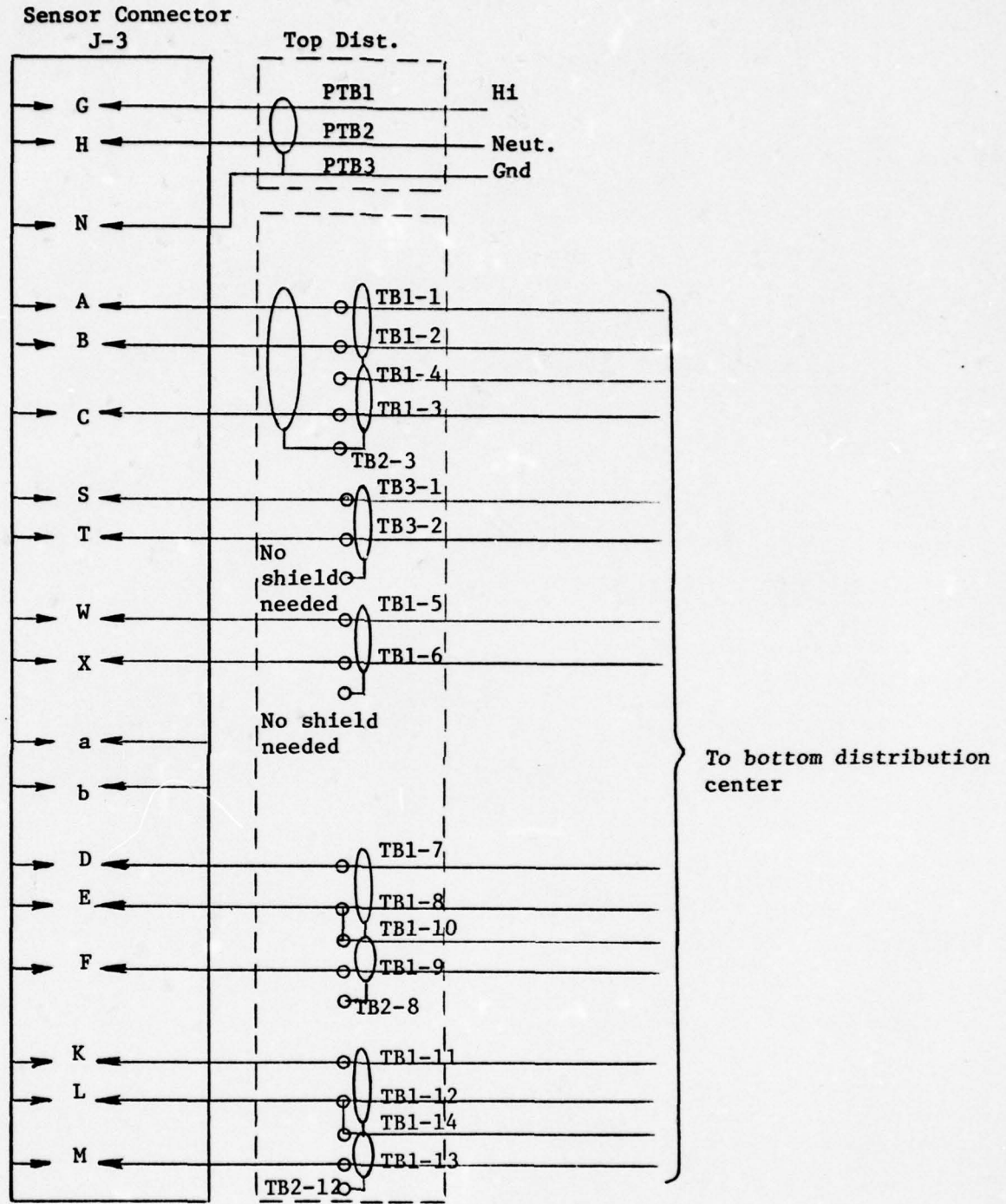

Note: Bottom dist. center wiring and connector wiring the same as the top.

Figure 38. Temperature/Dew-Point Wiring

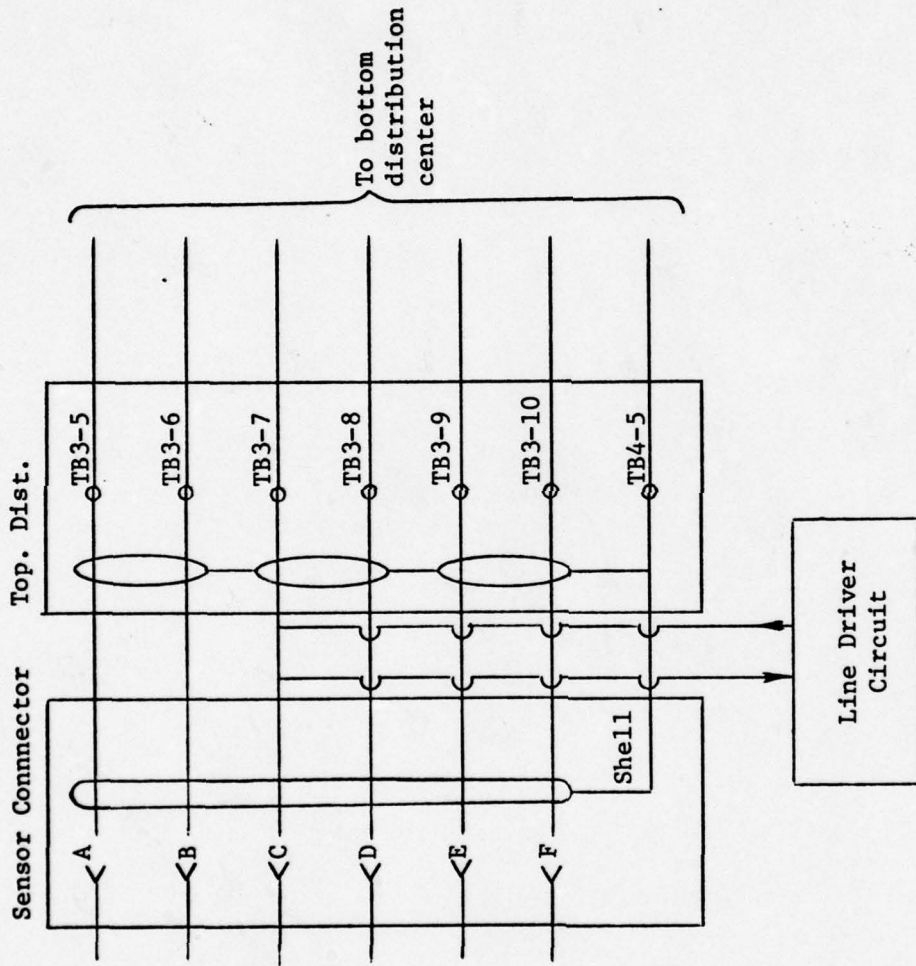

Note: Bottom dist. center wiring and connector wiring is the same except line driver is not used at bottom.

Figure 39. Barometer Wiring

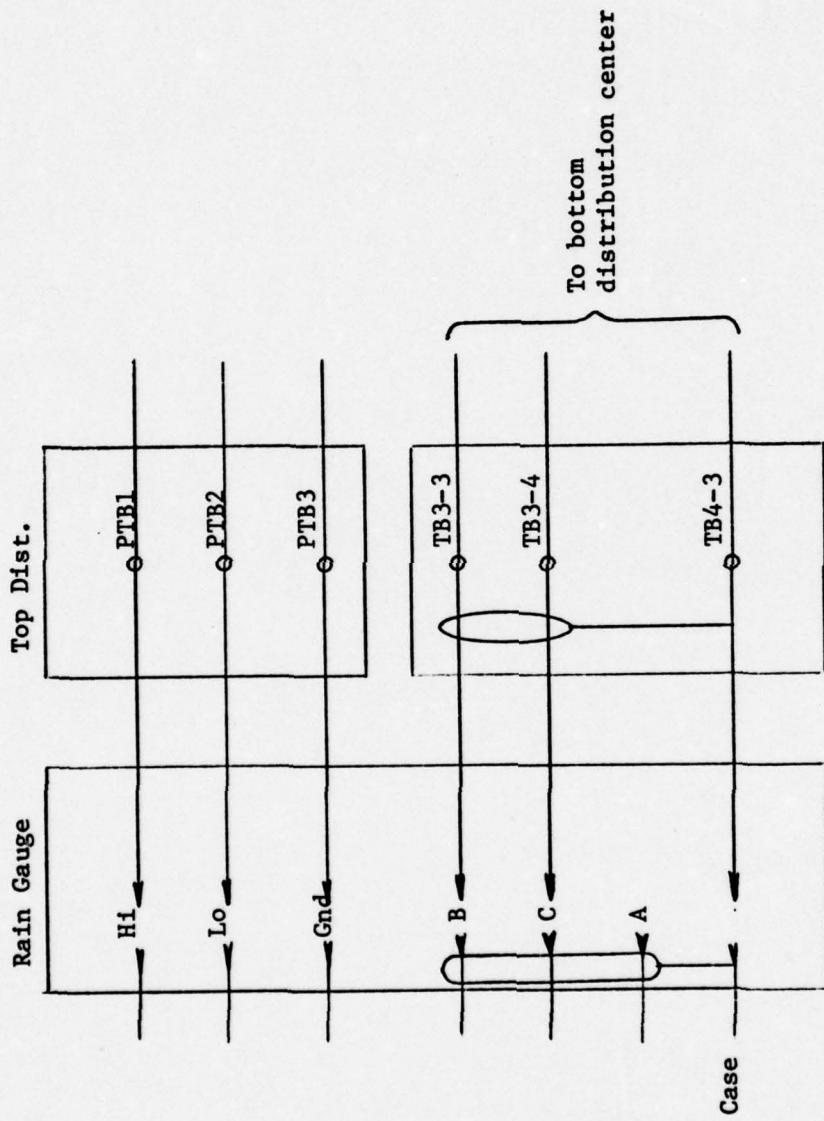

Note: Bottom dist. center wiring is same as top

Figure 40. Pluviometer Wiring

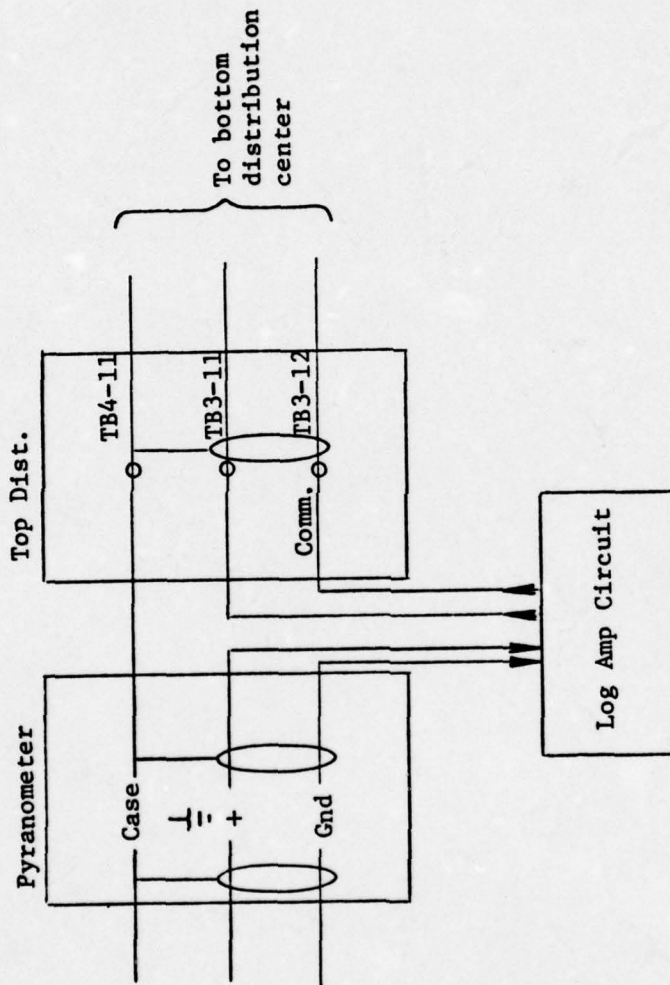

Note: Bottom dist. center wiring is same as top except log amp circuit not used at bottom

Figure 41. Pyranometer Wiring

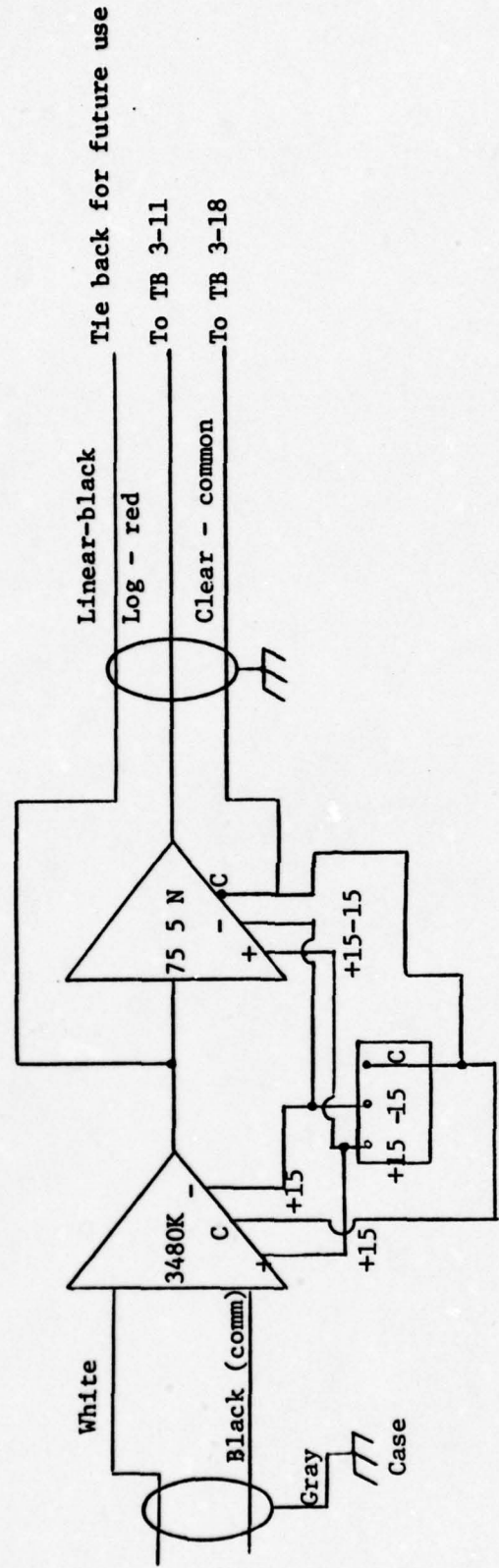
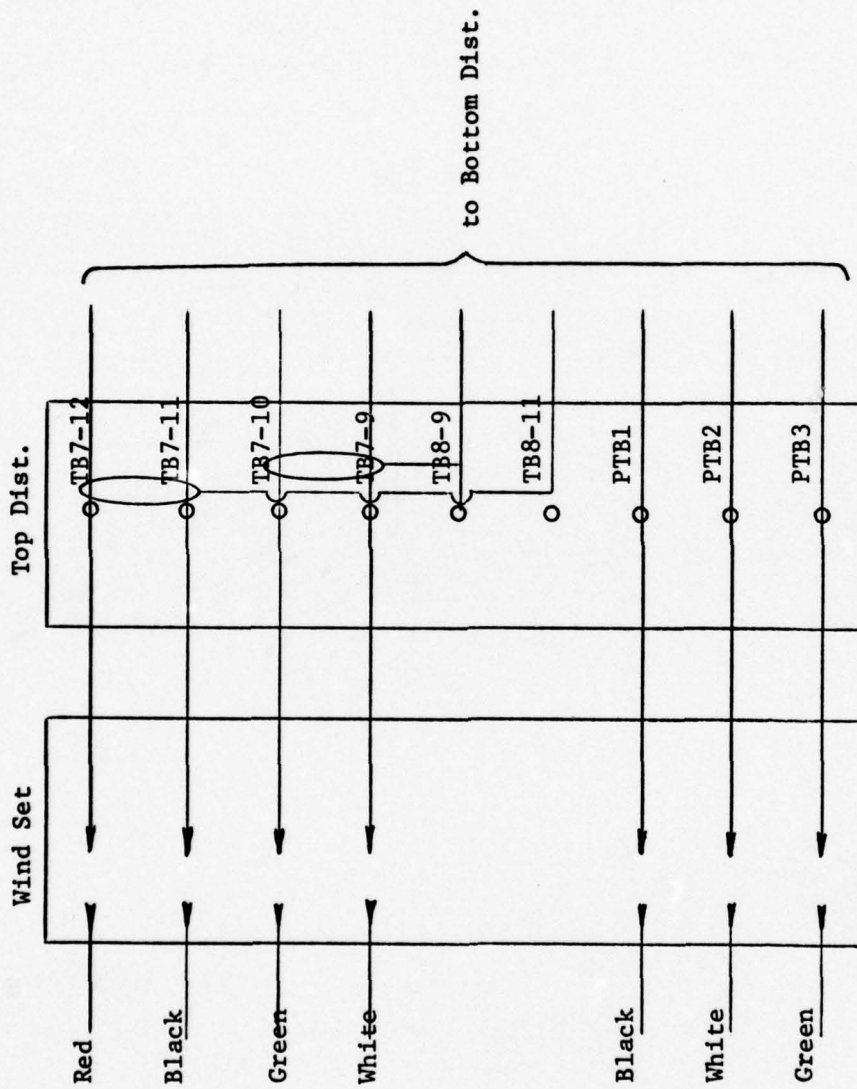

Figure 42. Pyranometer Log Amplifier



Note: Bottom dist. wiring same as top

Figure 43. Wind Set Wiring

control unit. A block diagram showing the separation of components is shown in Figure 44. Interface of the sensor unit to the cable system is shown in Figure 45.

In addition to the instruments on the cart, two stationary instruments were installed at the 4-km site. A tipping bucket rain gauge was placed on a 10-foot high pole attached at the southeast corner of the tower pad. The wiring consists of a 3-wire cord to supply 115-volt power to heaters and a pair of shielded wires. The shielded wires are used to detect switch openings/closings which occur each time the bucket fills and tips.

A temperature gauge was installed on the southeast tower face approximately 10 feet above ground level. It is similar to the temperature/dewpoint set except it does not contain a dewpoint sensor.

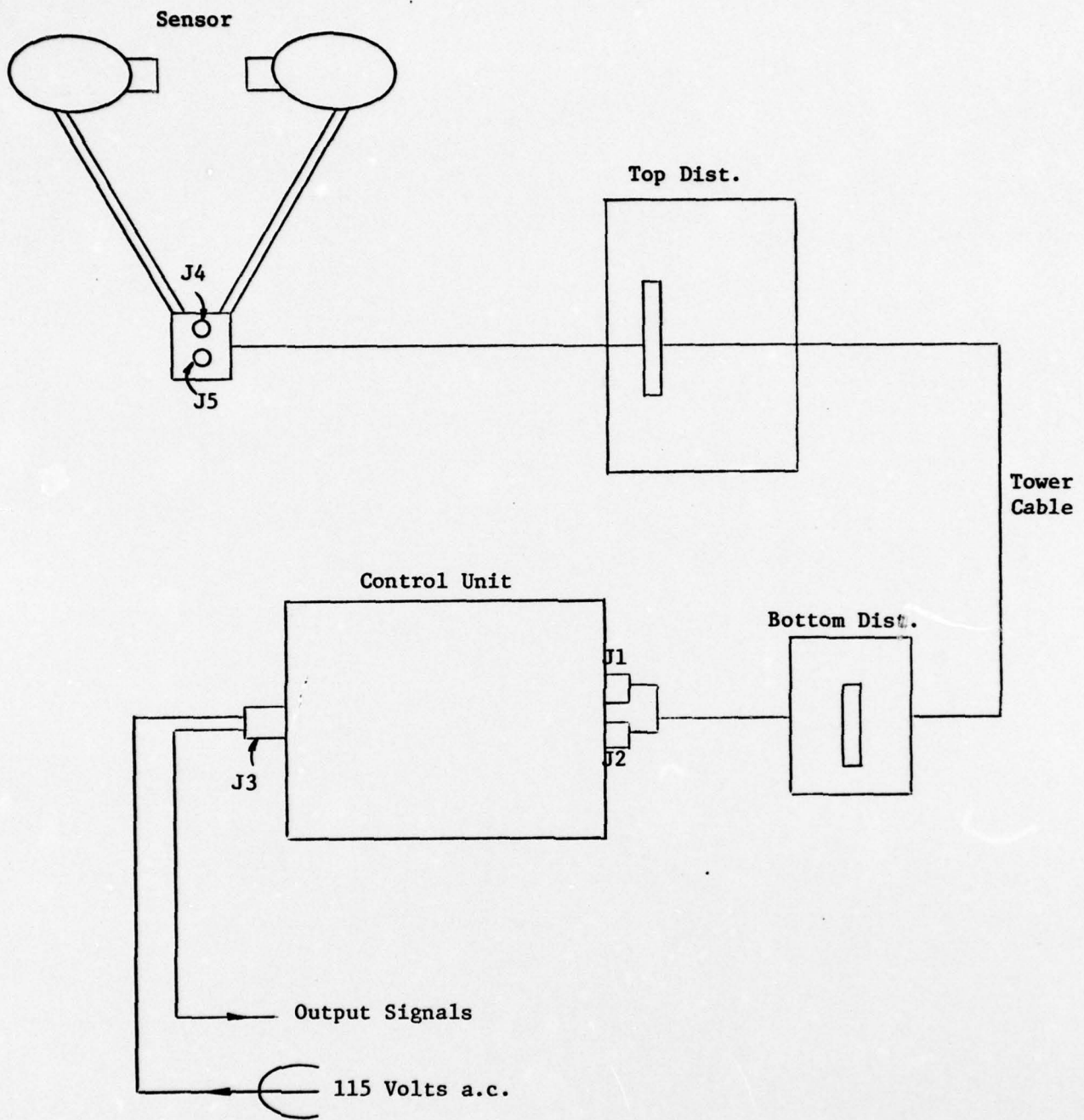

Figure 44. Forward Scatter Meter Block Diagram

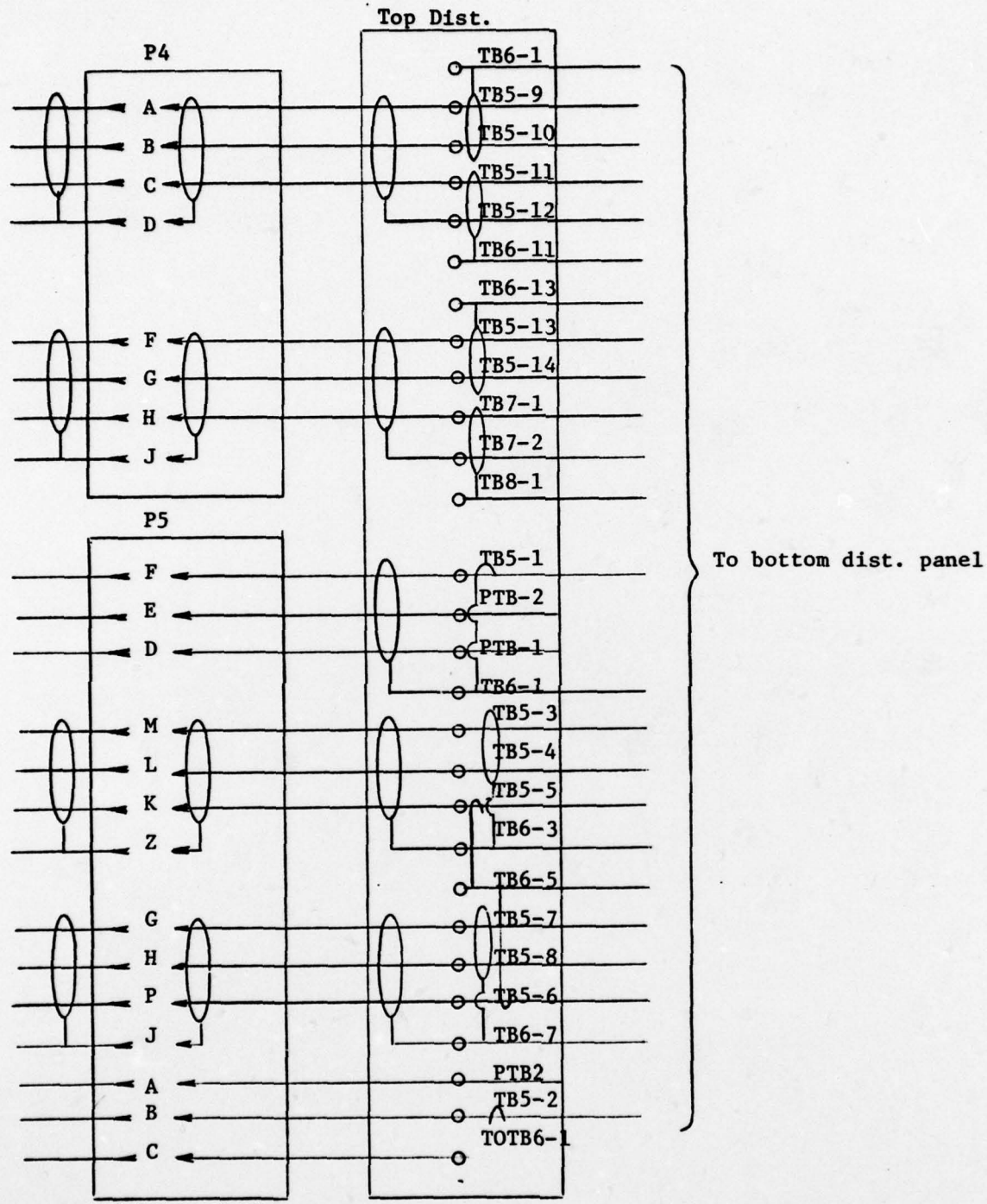

Figure 45. Forward Scatter Meter Wiring

APPENDIX A

LEASE AGREEMENT FOR 4-KM TOWER SITE

LEASE AGREEMENT

Entered into this 17th day of May, 1976, by and between Winters National Bank & Trust Co. and Robert A. Herbruck Co-Trustees and Winters National Bank & Trust Co., Trustee under Will of Virginia A. Balinge for O. Lee Balinge, LESSOR, and Systems Research Laboratories, Inc., LESSEE, under the following terms and conditions.

1. GRANT. Lessor does hereby rent and lease to Lessee the premises described in Exhibit "A" attached hereto and made a part hereof.
2. PURPOSE. Lessee will use the premises in a lawful manner, for the following purposes: Construction, maintenance and use of a structural steel tower. Lessee shall not use said premises for any other purpose without Lessor's prior written consent which shall not be unreasonably withheld.
3. TERM. To have and to hold the same for the term of 3 years commencing on the day of the signing of this lease agreement.
4. OPTION TO RENEW. Lessee shall have the option to extend the term of this Lease for seven (7) additional periods of one (1) year each upon the same terms and conditions, provided that Lessee shall give Lessor notice of its exercise of this option at least thirty (30) days prior to the expiration of the original term or any renewal term thereof.
5. RENTS. Lessee covenants and agrees to pay the Lessor, as rental for the leased premises, the following: Seven Hundred (\$700.00) Dollars per year, for each year of the initial three (3) year term and Seven Hundred (\$700.00) Dollars for each option year exercised. The initial payment for the 1st year is due on the date of the signing of this lease. The payment of the second and third year's rent and each renewal year thereafter is due on the anniversary date of the signing thereof.
6. RENTAL YEAR DEFINED. The term "Rental Year" shall mean a period of twelve (12) consecutive months during the lease term. The first such rental year shall commence on the day of the signing of this Lease Agreement.
7. UTILITIES. Lessee shall pay all public utility charges, and

shall be allowed to install or to have installed all utilities necessary or convenient for the purpose of this lease hereinbefore described.

8. MAINTAINANCE. The leased area shall be properly maintained during the term of this lease by Lessee or its assigns.

9. INTERFERENCE. Care will be taken by Lessee or its assigns to cause little, if any, interference to local television receivers.

10. FENCING AND GRAVEL. The leased area will be fenced at Lessee's expense with chain link fencing six (6) feet high, topped with three (3) strands of barbed wire and a gate to insure protection of possible grazing cattle in the adjacent field. Gravel will be put down, as required, to make the installation.

11. NOTICE TO ADJACENT LANDOWNERS. Notice of intent to install a tower will be given to landowners on Russell Drive, directly adjacent to the tower.

12. CONDITION OF PREMISES. Lessee shall deliver up and surrender the leased premises upon the expiration of this Lease or its termination in as good condition and repair as the same shall be at the commencement of said term. Footers and tower shall be removed, if Lessor desires, at Lessee's expense, and the area graded.

13. INDEMNITY. Lessee will indemnify and save Lessor harmless from any loss, cost or expense of any sort or nature, and from any liability to any person on account of any damage to person or property arising out of interference caused by the tower or its collapse.

14. QUIET ENJOYMENT. If Lessee shall perform all of the covenants and provisions herein, Lessee shall have the peaceful and quiet enjoyment and use of the Leased Premises without hindrance on the part of Lessor of any persons lawfully claiming through Lessor.

15. NOTICES. Rents are to be paid at the place designated as the place notices are to be sent to Lessor. All notices required or permitted by any provisions of the lease shall be directed as follows:

To Lessor: Trust Division
Winters National Bank & Trust Co.
Attn: Robert L. Apple
Assistant Vice President
Winters Bank Tower
Dayton, Ohio 45401

To Lessee: Systems Research Laboratories, Inc.
2800 Indian Ripple Road
Dayton, Ohio 45440

or to such other place as either party shall subsequently notify the other in writing.

16. SUCCESSORS AND ASSIGNS. This Lease shall be binding upon and inure to the benefit of the successors and assigns of the parties whenever the context so admits and if not prohibited by this Lease. Lessee shall have the right to assign its rights in this lease to the United States of America or its nominee.

IN WITNESS WHEREOF, the said parties have caused this Lease to be executed by their respective duly authorized officers on the day and year first above written:

Signed in the Presence of:

LESSOR: Winters National Bank & Trust Co.
and Robert A. Herbruck Co-Trustees
and Winters National Bank & Trust
Co., Trustee under Will of Virginia
A. Balinger for O. Lee Balinger

[Signature]

By *[Signature]*
Robert A. Herbruck, Trustee

Winters National Bank & Trust Co.,
Trustee

Robert L. Bennett
Louis J. Field

By *[Signature]*
Trust Officer
By *[Signature]*
Vice President

LESSEE: Systems Research Laboratories, Inc.

[Signature]

By *[Signature]*
William K. Bishoff, Vice Pres.
Legal & Contracts

STATE OF OHIO)
) SS:
MONTGOMERY COUNTY)

Before me, a Notary Public in and for said county and state, personally appeared The Winters National Bank & Trust Co., by John G. Duffy, its Trust Officer, and by L. Douglas Knisly, its Vice President, and Robert A. Herbruck, Co-Trustees, who acknowledged the signing of the foregoing instrument to be the free act and deed of said corporation, for the uses and purposes mentioned therein.

John W. Judge Engineering Company

CONSULTANT ENGINEERING

1201 EAST DAVID ROAD

DAYTON, OHIO 45429

Description of Land to be Leased to
Systems Research Laboratories, Inc.
by Bertha M. Herbruck
Greene County, Ohio

Situate in Section 29, Town 3, Range 7, Beavercreek Township,
Greene County, Ohio and being more particularly described as
follows:

PARCEL I

Being a parcel of land to be used jointly with others for ingress
and egress and utility purposes and beginning at a point on the
north right-of-way line at the east terminus of Russell Drive as
dedicated in College Hills Estates, Section No. 2 and recorded
in Book 10, Pages 64 and 65 of the Greene County Plat Records;

thence from said place of beginning S 88° 01' E passing an iron
pin at 50.00 feet, which iron pin is the point of beginning of
Parcel II, a total distance of 70.00 feet to an iron pin; thence
S 1° 59' W a distance of 50.00 feet to an iron pin; thence
N 88° 01' W a distance of 70.06 feet to a point on the east
boundary of said College Hills Estates, Section No. 2 and the
south right-of-way line of said Russell Drive; thence N 2° 03' E
with the plat boundary a distance of 50.00 feet to the place of
beginning containing 0.080 acres, more or less, subject, however,
to all legal easements of record.

PARCEL II

Being a parcel of land to be used for an antenna and appurtenances
and beginning at the iron pin on the north right-of-way line of
Russell Drive extended eastwardly 50.00 feet from the plat boundary
of College Hills Estates, Section No. 2;

thence from said place of beginning N 1° 59' E a distance of
20.00 feet to an iron pin; thence S 88° 01' E a distance of
20.00 feet to an iron pin; thence S 1° 59' W a distance of
20.00 feet to an iron pin; thence N 88° 01' W a distance of
20.00 feet to the place of beginning containing 0.009 acres,
more or less, subject, however, to all legal easements of record.

Deed Reference: Deed Book 161, Page 412

John W. Judge
John W. Judge
April 28, 1976

*NOT
Preceding Page BLANK - FILMED*

APPENDIX B
ROHN LIGHTING CONTROL SPECIFICATIONS

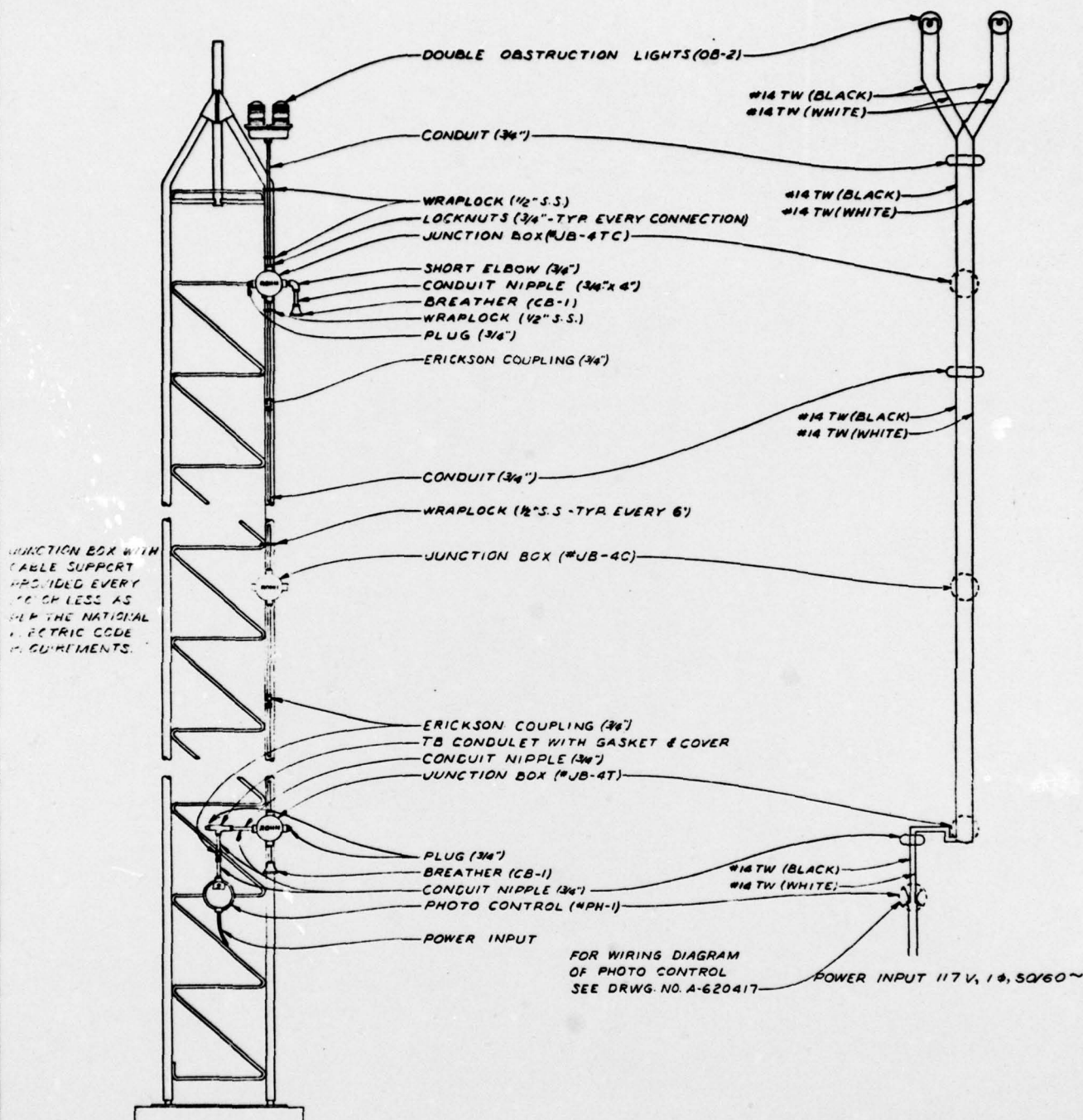

JUNCTION BOX WITH
CABLE SUPPORT
PROVIDED EVERY
60 FT OR LESS AS
PER THE NATIONAL
ELECTRIC CODE
REQUIREMENTS.

FOR WIRING DIAGRAM
OF PHOTO CONTROL
SEE DRWG. NO. A-620417

POWER INPUT 117 V, 1 ϕ , 50/60 ~

MATERIAL LAYOUT

WIRING DIAGRAM

LIGHTING KIT-CONDUIT-RA-1C-2

TOWER HEIGHT 101-150'
FAA #A-1

NOTES:

ALL CONNECTIONS MUST BE COMPLETELY TIGHT.
PHOTO CONTROL SHOULD FACE NORTHERN SKY.

64

DRAWN: HOFFMAN		CUSTOMER	TITLE
CHECKED: PTP			INSTALLATION DETAILS NO. RA-1C-2 LIGHTING KIT
APPROVED: [Signature]			DRAWING NO.
DATE: MAY 31 1962	ROHN MFG. PEORIA, ILLINOIS		G-620506-A
SCALE: NONE			

A	4-11-67 A.T.
NO.	REVISION

PARTS LIST

RA-1C2 LIGHTING KIT

101' to 150'
CONDUIT

1	Double obstruction light (OB-2)
1	Conduit nipple 3/4" x 18"
4	Obstruction light bulbs (OB-107W)
1	Junction box (JB-4TC)
1	Junction box (JB-4C)
1	Junction box (JB-4T)
1	Short elbow 3/4" (4251)
2	Conduit breathers (CB-1)
1	TB conduit w/cover and gasket 3/4" (TB-27)
3	Erickson couplings 3/4" (676)
5	Conduit nipples 3/4" x 4"
3	Plugs 3/4"
20	Conduit lock nuts 3/4"
1	Photo control w/meter socket (Fh-1)
1	Can SS wraplock (1/2" x 50')
1	Can joint compound
-	#14 TW wire - Black (tower height plus 15')
-	#14 TW wire - White (tower height plus 15')
-	3/4" rigid conduit - Galv. (tower height)

(Parts list may vary if tower is self supporting)

OBSTRUCTION LIGHTING COMPONENTS

<u>PART NUMBER</u>		<u>WT.</u>
B-1	300MM beacon with red filter screens - no bulbs	95
OB-1	Single obstruction light (red), 3/4" side entrance - no bulbs	4
OB-2	Double obstruction light (red), 3/4" to 1" bottom entrance - no bulbs	4
PH-1	Photo-electric control only, in outdoor housing (120 volt)	8
PH-2	Photo-electric control only, in outdoor housing (230 volt)	8
SSF-1	Solid-state beacon flasher only, in outdoor aluminum housing (120 volt)	
SSF-2	Solid-state beacon flasher only, in outdoor aluminum housing (230 volt)	
*LC-23	Discontinued	
*LC-45	Discontinued	
*LC-50	Discontinued	
*LC-55	Discontinued	
RC-23-1	A-2 or A-3 lighting control with combination solid-state flasher and photo-electric control in outdoor aluminum housing (120 volt)	15
RC-23-1-FS	A-2 or A-3 lighting control with combination solid-state flasher and photo-electric control in outdoor aluminum housing with fail safe feature (120 volt)	15
RC-23-2	A-2 or A-3 lighting control with combination solid-state flasher and photo-electric control in outdoor aluminum housing (230 volt)	15
RC-23-2-FS	A-2 or A-3 lighting control with combination solid-state flasher and photo-electric control in outdoor aluminum housing with fail safe feature (230 volt)	15
RC-45-1	A-4 or A-5 lighting control with combination solid-state flasher and photo-electric control in outdoor aluminum housing (120 volt)	16
RC-45-1-FS	A-4 or A-5 lighting control with combination solid-state flasher and photo-electric control in outdoor aluminum housing with fail safe feature (120 volt)	16
RC-45-2	A-4 or A-5 lighting control with combination solid-state flasher and photo-electric control in outdoor aluminum housing (230 volt)	16
RC-45-2-FS	A-4 or A-5 lighting control with combination solid-state flasher and photo-electric control in outdoor aluminum housing with fail safe feature (230 volt)	16
*F-CH1	Discontinued	
*F-CH2	Discontinued	
*F-CH1-FS	Discontinued	
*F-CH2-FS	Discontinued	
*LC-3	Discontinued	
*LC-3-FS	Discontinued	
MA-101-A1	A-1 alarm and photo-electric control unit only, in indoor housing	
MA-3015	A-2 or A-3 alarm, flasher and photo-electric control only, in indoor housing	
**LBRR-1200	Load balance resistor, outdoor or indoor (1200 watts)	
CB-1	Conduit breather, 3/4" tap	1/2
JB-4T	JB-4 junction box with 4 contact terminal blocks	3
JB-4C	JB-4 junction box with cable support	3
JB-4TC	JB-4 junction box with 4 contact terminal blocks and cable support	3
JB-7T	JB-7 junction box with 4 contact terminal blocks	6
JB-7C	JB-7 junction box with cable support	6
JB-7TC	JB-7 junction box with 4 contact terminal blocks and cable support	6
B-620W	beacon bulbs (3000 hour) - 120 volts (case of 24 bulbs)	
OB-116W	obstruction light bulbs (8000 hour) - 120 volts (case of 120 bulbs)	
B-600W	beacon bulbs - 230 volts (case of 24 bulbs)	
OB-100W	obstruction light bulbs - 230 volts (case of 120 bulbs)	
WR-100	Can of 100' x 1/2" stainless steel wraplock with buckles, keys and ratchet wrench	3
WR-50	Discontinued	
LR-B-1	Lightning rod, 7/8" x 5' solid aluminum, assembly with base for 300MM beacon	6
LR	Lightning rod, 7/8" x 5' solid aluminum, only with nut (Rohn beacon mounting plates drilled to fit this rod)	3
LR-C	Lightning rod, 5/8" x 5' solid copper, nickel tipped, only with nut (Rohn beacon mounting plates drilled to fit this rod)	6

*Replacement parts available only.

**For use with alarm lighting kits only. LBRR-1200 not required for RC-45 units. A-2 or A-3 lights requiring a LBRR-1200 must use a RC-45 flasher.

Refer to alphabetical/numerical price list for current prices.

F.O.B. PEORIA, ILLINOIS
SPECIFICATIONS SUBJECT TO CHANGE WITHOUT NOTICE.

TOWER OBSTRUCTION LIGHTING KITS

<u>TOWER HEIGHT</u>	<u>STANDARD KIT PART NUMBER</u>	<u>230V, 50 CYCLE KIT PART NUMBER</u>	<u>*SELF-SUPPORTING KIT W/3rd OB-1 PART NUMBER</u>
<u>EXPOSED WIRE</u>			
21' - 150'	RA-1E	RA-1E-E	---
151' - 230'	RA-2E1	RA-2E1-E	RA-2E1-SS
231' - 300'	RA-2E2	RA-2E2-E	RA-2E2-SS
301' - 360'	RA-3E1	RA-3E1-E	RA-3E1-SS
361' - 450'	RA-3E2	RA-3E2-E	RA-3E2-SS
<u>CONDUIT</u>			
21' - 100'	RA-1C1	RA-1C1-E	---
101' - 150'	RA-1C2	RA-1C2-E	---
151' - 200'	RA-2C1	RA-2C1-E	RA-2C1-SS
201' - 300'	RA-2C2	RA-2C2-E	RA-2C2-SS
301' - 350'	RA-3C1	RA-3C1-E	RA-3C1-SS
351' - 450'	RA-3C2	RA-3C2-E	RA-3C2-SS
451' - 600'	RA-4C	RA-4C-E	---
601' - 750'	RA-5C	---	---
<u>MICROWAVE</u>			
21' - 100'	RA-1C1M	---	---
101' - 150'	RA-1C2M	---	---
151' - 200'	RA-2C1M	---	RA-2C1M-SS
201' - 300'	RA-2C2M	---	RA-2C2M-SS
300' - 450'	RA-3CM	---	RA-3CM-SS
451' - 600'	RA-4CM	---	---

All kits include photo control, necessary wire, fittings, junction boxes, lights, spare bulbs and flasher (where required). Microwave kits also include indoor alarm unit with remote photo-control. The 230V, 50 cycle kit price includes export crating and outdoor controls. See drawings and parts lists for details. *Optional, for additional side lights (3 at each level).

NOTE: Prices are available on request for special kits for towers over 750', High Intensity Strobe Lighting Kits and I.C.A.O. Lighting Kits.

Refer alphabetic/numeric price list for current prices.

F.O.B. PEORIA, ILLINOIS

SPECIFICATIONS SUBJECT TO CHANGE WITHOUT NOTICE.

REPLACEMENT PARTS FOR OBSTRUCTION LIGHTING

PART NUMBER

OB-1 & OB-2 OBSTRUCTION LIGHTS

530230	OB red lens (AP-3522-2R)
OBG-1	Gasket
OBR	OB retainer ring
OBC	OB catch
50714	OB bulb receptacle

B-1 BEACON

711130	Red filter screen for beacon (AP-3524) - 2 required per beacon
547870	Top beacon lens (AP-3557/530870)
547770	Middle beacon lens (AP-3556/530770)
547020	Bottom beacon lens (AP-3555/531020) - 2 required per beacon
BGS	Set of 9 beacon gaskets
BG-T1	Gasket (1 per beacon)
BG-T2	Gasket (3 per beacon)
BG-M1	Gasket (1 per beacon)
BG-B1	Gasket (4 per beacon)
BRR-1	Upper "Z" ring (between 547870 & 547770)
BRR-2	Lower "Z" ring (between 547020 & 547020)
23X546	Beacon bulb receptacle
WBS	Beacon asbestos wiring (inside) - complete set
CTOC	Canopy top outer cap

MISCELLANEOUS

MSK	Meter socket only
F-12	Discontinued
F-122	Discontinued
F-12-M	Discontinued
F-12-C	Discontinued
F-12-I	Discontinued
F-12-CS	Discontinued
2232	Water tight connector for 2 conductor (2-#12) - neoprene
2237	Water tight connector for 2 conductor (2-#12) - UF cable
2534	Water tight connector for 3 conductor (2-#10, 1-#14)
2535	Water tight connector for 3 conductor (1-#6, 1-#8, 1-#12) (2-#8, 1-#12)

Refer to alphabetical/numerical price list for current prices.

F.O.B. PEORIA, ILLINOIS

SPECIFICATIONS SUBJECT TO CHANGE WITHOUT NOTICE.

REPLACEMENT PARTS FOR OBSTRUCTION LIGHTING

PART NUMBER

F-CH1 & F-CH2 FLASHER UNITS*

CHM Flasher motor
MTS Mercury tilt switch
CSF Coupler spring
FCM Cam

LC-23 FLASHER UNIT*

MS-6078 Flasher motor only
AU-5216 Flasher motor w/rocker arm ass'y.
KR-5045 Relay, SPDT
AU-5106-2 Photocell assembly, H.D. static voltage resistant
AU-5106-2H Photocell assembly w/housing & cable
AU-5041 Printed circuit board ass'y.
VR-5061 Thyrector
CE-4393-2 Capacitor
RC-4198-37A Resistor
RV-4392 Potentiometer
SW-4800 Mercury tilt switch

LC-45 FLASHER UNIT*

MS-6078 Flasher motor only
AU-5268 Flasher motor w/rocker arm ass'y.
KR-5044 Relay, DPDT
AU-5106-2 Photocell assembly, H.D. static voltage resistant
AU-5106-2H Photocell assembly w/housing & cable
AU-5041 Printed circuit board ass'y.
VR-5061 Thyrector
CE-4393-2 Capacitor
RC-4198-37A Resistor
RV-4392 Potentiometer
SW-4800 Mercury tilt switch

MA-101-A1 MICROWAVE FLASHER UNIT

KR-4391 Relay
KR-4419-1 Relay, DPDT
KR-1090-A Relay, current
RW-4260-3 Resistor
CE-4393-2 Capacitor
RV-4392 Potentiometer
VR-4389-A Thyrector
AU-4390 Printed circuit board ass'y.
AU-5106-2 Photocell assembly, H.D. static voltage resistant
AU-5106-2H Photocell assembly w/housing & cable

PART NUMBER

MA-3105 MICROWAVE FLASHER UNIT

MS-6078 Flasher motor only
AU-5216 Flasher motor w/rocker arm ass'y.
KR-4391 Relay
KR-4777 Relay, mercury
KR-4782-A Relay, thermal
KR-1090-A Relay, current
KR-1202-1A Relay, thermal
KR-4790 Relay, thermal
KR-4419-1 Relay, DPDT
KR-4221 Relay, SPDT
KR-4494 Relay, 3PDT
KR-1202-A Relay, thermal
AU-4390 Printed circuit board ass'y.
RV-4392 Potentiometer
CE-4393-2 Capacitor
CP-4271B-40 Capacitor
VR-4389-A Thyrector
VR-4389-B Thyrector
RW-4260-3 Resistor
RC-4197-87A Resistor
AU-5106-2 Photocell assembly, H.D. static voltage resistant
AU-5106-2H Photocell assembly w/housing & cable
SW-4840 Mercury tilt switch

RC-23-1 & RC-23-2 FLASHER UNITS

SSM-11 Flasher drive module (120 volt)
or
SSM-12 Flasher drive module (230 volt)
KR-5045 Relay, SPDT
512 Rectifier
TC-493-B Capacitor
A13X20 Fuse
NSL-446 Photocell

RC-45-1 & RC-45-2 FLASHER UNITS

SSM-11 Flasher drive module (120 volt)
SSM-21 Flasher slave module (120 volt)
or
SSM-12 Flasher drive module (230 volt)
SSM-22 Flasher slave module (230 volt)
KR-5045 Relay, SPDT
512 Rectifier
TC-493-B Capacitor
A13X20 Fuse
NSL-446 Photocell

*Discontinued. Replacement parts available only.

Refer to alphabetical/numerical price list for current prices.

F.O.B. PEORIA, ILLINOIS

SPECIFICATIONS SUBJECT TO CHANGE WITHOUT NOTICE.