

AD-A049 663

NAVAL SURFACE WEAPONS CENTER WHITE OAK LAB SILVER SP--ETC F/G 13/13  
JUNCTION INPUT GENERATOR (JIG), A NASTRAN PRE-PROCESSOR; THEORE--ETC(U)  
SEP 77 P C HUANG, K C KIDDY, J P MATRA  
NSWC/WOL/TR-77-85

UNCLASSIFIED

NL

OF 3  
AD  
A049663



12  
B.S.

AD A 049663

NSWC/WOL TR 77-85

# JUNCTION INPUT GENERATOR (JIG), A NASTRAN PRE-PROCESSOR, THEORETICAL DEVELOPMENT, USER'S MANUAL AND PROGRAM LISTING.

ADJ. NO. \_\_\_\_\_  
JDC FILE COPY

BY PAO C. HUANG  
KENNETH C. KIDDY  
JOHN P. MATRA, JR.

ADVANCED WEAPONS DEPARTMENT

SEPTEMBER 1977

APPROVED FOR PUBLIC RELEASE; DISTRIBUTION UNLIMITED

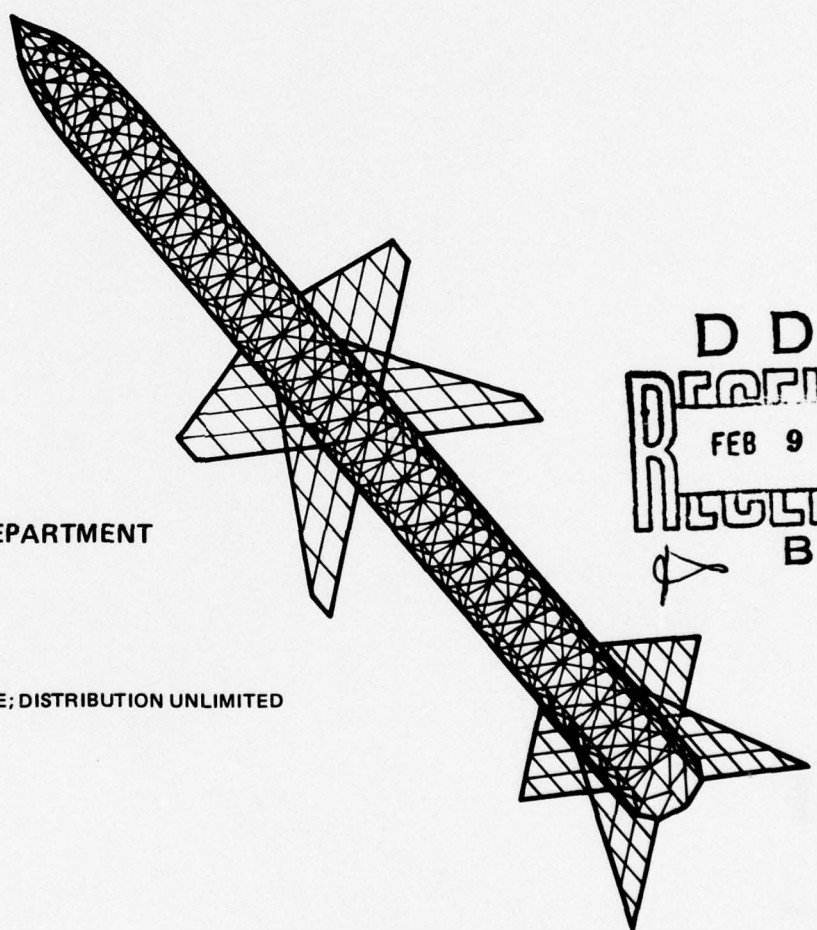

DDC  
RECEIVED  
FEB 9 1978  
B



## NAVAL SURFACE WEAPONS CENTER

Dahlgren, Virginia 22448 • Silver Spring, Maryland 20910

UNCLASSIFIED

SECURITY CLASSIFICATION OF THIS PAGE (When Data Entered)

12

REPORT DOCUMENTATION PAGE

READ INSTRUCTIONS BEFORE COMPLETING FORM

1. REPORT NUMBER NSWC/WOL/TR-77-85	2. GOVT ACCESSION NO.	3. RECIPIENT'S CATALOG NUMBER
4. TITLE (and Subtitle) Junction Input Generator (JIG), A NASTRAN Pre-Processor; Theoretical Development, User's Manual and Program Listing.	5. TYPE OF REPORT OR PERIOD COVERED Rept. for Manual 7/75 to 7/77	
7. AUTHOR(s) Pao. C. Huang, Kenneth C. Kiddy, John P. Matra, Jr.	6. PERFORMING ORG. REPORT NUMBER Jul 75-Jul 76	
9. PERFORMING ORGANIZATION NAME AND ADDRESS Naval Surface Weapons Center White Oak Laboratory White Oak, Silver Spring, Maryland 20910	10. PROGRAM ELEMENT (PROJECT, TASK AREA & WORK UNIT NUMBERS) 62332N, F32-322 SF32-322-501; WA71EA;	
11. CONTROLLING OFFICE NAME AND ADDRESS SF32322501	12. REPORT DATE September 1977	
14. MONITORING AGENCY NAME & ADDRESS (if different from Controlling Office) 12/299p.	13. NUMBER OF PAGES 206	
	15. SECURITY CLASS. (of this report) UNCLASSIFIED	
	15a. DECLASSIFICATION/DOWNGRADING SCHEDULE	

16. DISTRIBUTION STATEMENT (of this Report)  
Approved for Public Release; Distribution Unlimited

17. DISTRIBUTION STATEMENT (of the abstract entered in Block 20, if different from Report)  
DDC  
REFORMED  
FEB 9 1978  
RECEIVED  
B

18. SUPPLEMENTARY NOTES

19. KEY WORDS (Continue on reverse side if necessary and identify by block number)  
NASTRAN Pre-Processor  
Missile Joints  
Finite Element Model  
Massive Junctions

20. ABSTRACT (Continue on reverse side if necessary and identify by block number)  
A Missile Junction Input Generator (JIG, A NASTRAN pre-processor) is presented in this report. It is a pre-processor for NASTRAN analyses of missile junctions. Using JIG a finite element model can be automatically generated and NASTRAN bulk data cards punched, thus enabling a complicated structure to be accurately and rapidly analyzed.

DD FORM 1473 1 JAN 73

EDITION OF 1 NOV 65 IS OBSOLETE S/N 0102-LF-014-6601

UNCLASSIFIED SECURITY CLASSIFICATION OF THIS PAGE (When Data Entered)

39-1596

Handwritten initials

[Faint, mostly illegible text, possibly bleed-through from the reverse side of the page. Some words like "CLASSIFIED" and "SECRET" are faintly visible.]

D D C  
 13 2 1978  
 SECRET

PREFACE

Junction Input-Generator (JIG), A NASTRAN Pre-Processor; Theoretical Development, User's Manual and Program Listing. This is the fourth of a series of Project LIMIT Reports; the first two were on the Planform Input Generator (PING) and the third the Body Input Generator (BING).

The work reported herein is being carried out under task No. SEA-18452/SF32-322-501, Lightweight Missile Structure, sponsored by the Naval Sea Systems Command.

*J. M. Wack*  
 J. M. WACK

By direction

ACCESSION for		
NTIS	White Section	<input checked="" type="checkbox"/>
DDC	Buff Section	<input type="checkbox"/>
UNANNOUNCED		<input type="checkbox"/>
JUSTIFICATION _____		
BY _____		
DISTRIBUTION/AVAILABILITY CODES		
Dist.	AvAIL. and/or	SPECIAL
A		

## CONTENTS

	Page
Foreword.....	8
1. Introduction.....	10
2. Missile Junction Input Generator.....	13
2.1 Axially Symmetrical Joints and Nozzles.....	16
2.2 Bayonet Joints - Axially Unsymmetrical case...	18
2.3 Threaded Joints.....	21
2.4 JIG and BING Coupling.....	21
2.5 Other Useful Features.....	24
3. User's Manual.....	26
3.1 Format of JIG Card Types.....	29
Appendix A - JIG Fortran Listing.....	A-1
Appendix B - Demonstration Problems.....	B-1

## ILLUSTRATIONS

Figure	Title	Page
1	Functions of JIG/NASTRAN.....	14
2	Mesh Planning.....	17
3	Mesh with Transition Feature.....	17
4	Nozzle Cross Section Curved Boundary.....	19
5	Bayonet Joint.....	20

## ILLUSTRATIONS

Figure	Title	Page
6	Mesh of Part of Bayonet Joint.....	20
7	Threaded Joint.....	22
8	Joint Shell Interface.....	22

## TABLES

Table	Title	Page
1	JIG Output Punch Options.....	15
2	JIG Element Punch Options.....	27

## ILLUSTRATIONS

Appendix	Title	Page
B-1	Finite Element Model and Configuration of The Cross Section of a Solid Ring.....	B-3
B-2	Data Input Problem B-I-A.....	B-4
B-3	Grid Point and Element Identification Numbers.....	B-5
B-4	NASTRAN Structural Plot.....	B-6
B-5	Data Input Problem B-I-B.....	B-10
B-6	Grid Point and Element Identification Numbers.....	B-11
B-7	NASTRAN Structural Plot.....	B-12
B-8	Data Input Problem B-I-C.....	B-16
B-9	Grid Point and Element Numbers.....	B-17
B-10	Grid Point Numbers.....	B-18
B-11	NASTRAN Structural Plot.....	B-20

## ILLUSTRATIONS (CONT.)

Appendix	Title	Page
B-12	Planned Finite Element Model and Configuration of a Bayonet Joint.....	B-32
B-13	Planned Finite Element Model and Configuration of a Bayonet Joint.....	B-33
B-14	I-J Mesh of Section A of the Bayonet Joint....	B-34
B-15	I-J Mesh of Section B of the Bayonet Joint....	B-35
B-16	Data Input Problem B-II - Section A Bayonet Joint.....	B-36
B-17	Data Input Problem B-II - Section B Bayonet Joint.....	B-37
B-18	Grid Point and Element Numbers $0^{\circ}$ to $15^{\circ}$ Sector.....	B-38
B-19	Grid Point and Element Numbers $15^{\circ}$ to $45^{\circ}$ Sector.....	B-39
B-20	Grid Point and Element Numbers $0^{\circ}$ to $15^{\circ}$ Sector.....	B-40
B-21	Grid Point and Element Numbers $15^{\circ}$ to $45^{\circ}$ Sector.....	B-41
B-22	NASTRAN Structural Plot-End View Section A....	B-42
B-23	NASTRAN Structural Plot-Rotated View Section A.....	B-43
B-24	NASTRAN Structural Plot-End View Section B....	B-51
B-25	NASTRAN Structural Plot-Rotated View Section B.....	B-52

## ILLUSTRATIONS (CONT.)

Appendix	Title	Page
B-26	Planned Finite Element Model and Configuration of One Half of a Threaded Joint.....	B-62
B-27	Data Input Problem B-III - Repeated Section...	B-63
B-28	Grid Point and Element Numbers.....	B-64
B-29	Grid Point and Element Numbers.....	B-65
B-30	NASTRAN Structural Plot.....	B-66
B-31	Planned Finite Element Model and Configuration of a Thick Tapered Cylindrical Shell Using The Variable Theta Feature.....	B-76
B-32	Data Input Problem B-IV.....	B-77
B-33	Grid Point and Element Numbers.....	B-78
B-34	NASTRAN Structural Plot - End View.....	B-79
B-35	NASTRAN Structural Plot - Rotated View.....	B-80
B-36	Planned Finite Element Model and Configuration of a Solid Ring Containing Both Fixed Lines and Points.....	B-93
B-37	Data Input Problem B-V - Prescribed Points and Lines.....	B-94
B-38	Grid Point and Element Numbers.....	B-95
B-39	NASTRAN Structural Plot.....	B-96
B-40	Planned Finite Element Model and Configuration of a Solid Cylindrical Ring Containing Coarse to Fine Then Back to Coarse Regions.....	B-101
B-41	Data Input Problem B-VI - Transitions.....	B-102

## ILLUSTRATIONS (CONT.)

Appendix	Title	Page
B-42	Grid Point and Element Numbers.....	B-103
B-43	NASTRAN Structural Plot.....	B-104
B-44	Planned Finite Element Model and Configuration of a Missile Joint.....	B-112
B-45	Data Input Problem B-VII - MPC Generator.....	B-113
B-46	Grid Point and Element Numbers.....	B-114
B-47	NASTRAN Structural Plot Showing Cross Section of Joint.....	B-115
B-48	NASTRAN Structural Plot - Rotated View.....	B-116
B-49	Planned Finite Element Model and Configuration of a Missile Nozzle.....	B-124
B-50	Data Input Problem B-VIII - Curved Boundary...	B-125
B-51	Grid Point and Element Numbers.....	B-126
B-52	NASTRAN Structural Plot.....	B-127

FOREWORD

The object of Project LIMIT (Lightweight Missile Technology) is to develop and provide computer analysis methods for missile structures. Together with the use of lightweight materials, fabrication techniques and related technology, the design of a missile with optimized structural elements can be made practical from a computational time and expense standpoint. The merits of these techniques will permit different missile structural concepts to be both thoroughly and repeatedly analyzed in the development of an efficient weapon system.

This work develops the third pre-processor code to increase the utility of the NASTRAN program for the design and analysis of massive junctions in missile body structure. The first two pre-processors which can be employed for lifting surfaces and shell bodies have been completed and reported.

Project LIMIT Report

	Develop- ment Period	Computer Code Statue	Report
<p>PHASE - I PING</p> <p>Planform input generator (PING) Program develops finite element models for missile lifting surfaces and punches NASTRAN bulk data cards.</p>	July 71 to June 73	Opera- tional	NOLTR 73-199 NOLTR 73-228
<p>PHASE - II BING</p> <p>Body input generator (BING) Program develops finite element models for axi-symmetrical shell body and punches NASTRAN bulk data cards.</p>	July 73 to June 75	Opera- tional	NSWC/WOL/TR 75-9
<p>PHASE - III A MASSIVE JOINT JUNCTIONS</p> <p>Program develops finite element models for massive joint junctions and punches NASTRAN bulk data cards.</p>	July 75 to Aug 77	Opera- tional	NSWC/WOL/TR 77-85
<p>PHASE - III B AERO-ELASTICITY INTERACTION</p> <p>PHASE - III C AERO-DYNAMIC HEATING INTERACTION</p> <p>Programs automatically calculate air loads and temperatures due to aerodynamic heating and punch NASTRAN bulk data cards.</p>	Aug 77 to June 81	Under Develop- ment	Future

## Chapter I

## INTRODUCTION

The object of Project LIMIT (Lightweight Missile Technology), sponsored by the Naval Sea Systems Command, is to provide modern structural analysis methods together with lightweight materials, fabrication techniques and related technology whereby a missile may be designed economically and efficiently with weight-optimized structural elements. The current phase of the work aims to promote finite element techniques in the design and analysis of missile structure. The great speed and precision of these techniques would permit a missile to be thoroughly and repeatedly analyzed and thus provide a more efficient weapon system.

NASTRAN, a general purpose finite element program for structural analysis, was developed by NASA and is gaining wide acceptance through the technical community especially among Naval Laboratories. It is versatile and applies to a large class of static and dynamic problems:

- a. Static response to concentrated and distributed loads, thermal expansion and enforced deformation .
- b. Dynamic response to transient loads and random excitation.
- c. Determination of real and complex eigen values for use in vibration analysis, dynamic stability analysis and elastic stability analysis.

However, to prepare NASTRAN input for a complicated problem is a large effort in itself. It includes the layout of grid mesh; calculation of grid point locations; element properties and their connections to grid points; preparation of input sheets; and, finally, punching of input cards. All this work is extremely time consuming and requires a team of specialists. Furthermore, possible occurrences of human errors together with unavoidable redesign cycles would make the analysis formidable. To remedy these difficulties, special input generation programs are being developed to automatically generate finite element models and the associated NASTRAN input for missile structures. This work will be completed in three phases. In the initial phase a pre-processor has been completed for lifting surfaces; the work was published in NOLTR 73-199, entitled "Planform Input Generator (PING), a NASTRAN Pre-processor for Lifting Surfaces - Theoretical Development, User's Manual, and Program Listing" December 1973. The second phase has concluded with a report entitled "Missile Body Input Generator (BING), A NASTRAN Pre-processor, Theoretical Development, User's Manual, and Program Listing". This report was published as a NSWC/WOL/TR 75-9 in March 1975.

The third phase, concerned with massive bodies and junctions in missile structure, is documented in this report. These three pre-processors together can supply most of the bulk data cards for a NASTRAN analysis of a complete missile structure.

This Junction Input Generator, designated as JIG, can rapidly develop a finite element model and NASTRAN bulk data cards for any massive body such as a joint or nozzle for elaborate structural analysis. Chapter 2 discusses the background of the program and its applications.

Chapter 3 presents the user's manual. Appendix A lists the complete program. Appendix B presents example problems with complete input procedure and NASTRAN bulk data listings.

## Chapter 2

## MISSILE JUNCTION INPUT GENERATOR

JIG, written in FORTRAN, can generate the finite element model for a massive shell junction and most of the bulk data cards required for NASTRAN application. Figure 1 shows the functions of JIG and its relation with NASTRAN.

This code has the option of punching out various combinations of bulk data cards, listed in Table 1, to avoid accumulating thousands of unwanted cards. This feature is especially feasible in the design - redesign cycles where most of the NASTRAN input remain unchanged.

Table 1 lists punch options for the connection and grid cards,. These include:

- a. Triangular Plate Element (CTRIA2) only.
- b. Triangular Ring Element (CTRIARG) only.
- c. Triangular Ring and Plate Elements (CTRIA2 and CTRIARG).
- d. Polyhedron Elements (CWEDGE) only.
- e. Grid cards punched or not punched.

The three dimensional axisymmetric triangular ring element (CTRIARG) and the solid polyhedron element (CWEDGE) are employed here as the basic finite elements for the analyses of massive body and joint structure. The inclusion of CWEDGE is provided for the capability of analyzing non-axisymmetric bodies and also the compatibility of this element with other NASTRAN elements.

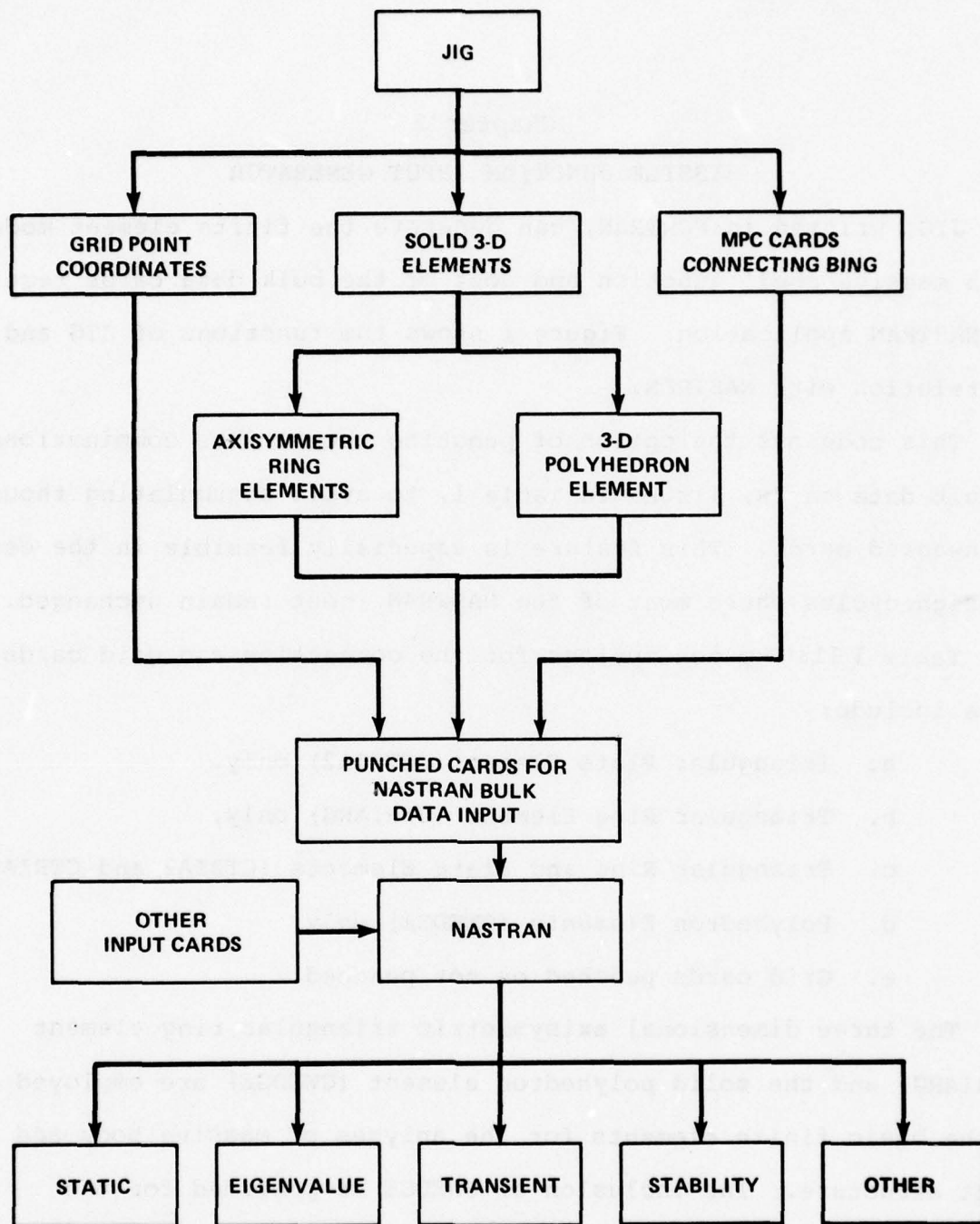

FIG. 1 FUNCTIONS OF JIG/NASTRAN

Table 1  
JIG Output Punch Options

Connection Cards

Punch Options	Type(s) of Element Cards
0	CTRIA2 only
1	CTRIARG only
2	CTRIA2 and CTRIARG
3	CWEDGE only

Grid Cards

Punch Option	Comment
0	grid cards punched
1	grid cards not punched

Using JIG, only a typical configuration in R-Z plane will be required for the creation of the three-dimensional finite element model. JIG will calculate and punch the GRID and/or the connection cards for the entire structure. The same subroutine developed in PING is adopted here for computing the mesh points and the boundary points.

Control points along the boundaries are input to define the configuration, then additional boundary points are calculated by the program. Finally the internal mesh points are calculated by the method of iteration. Figures 2 and 3 show the control points A,B,C,D,E and F and the mesh points.

For a tapering mesh such as Figures 2 and 3 the transition technique from PING can be applied to great advantage. This technique reduces the number of mesh points in the narrower sections thus yielding a finite element model with better proportioned elements. Figure 3 shows the mesh of such a finite element model and an example can be found in Appendix B.

#### 2.1 AXIALLY SYMMETRICAL JOINTS AND NOZZLES

Most massive junctions and nozzles are axially symmetrical structures. Hence the axisymmetric triangular ring element (CTRIARG) can be advantageously employed, despite the incompatibility of this element with other NASTRAN finite elements. For the convenience of modeling a nozzle type configuration, curved boundary between two boundary points has been incorporated in this program. The following equation

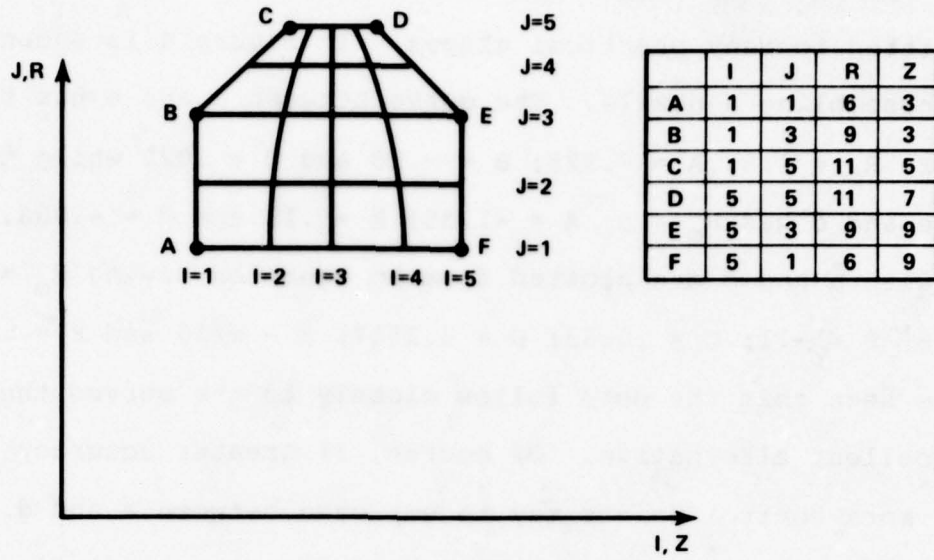

FIG. 2 MESH PLANNING

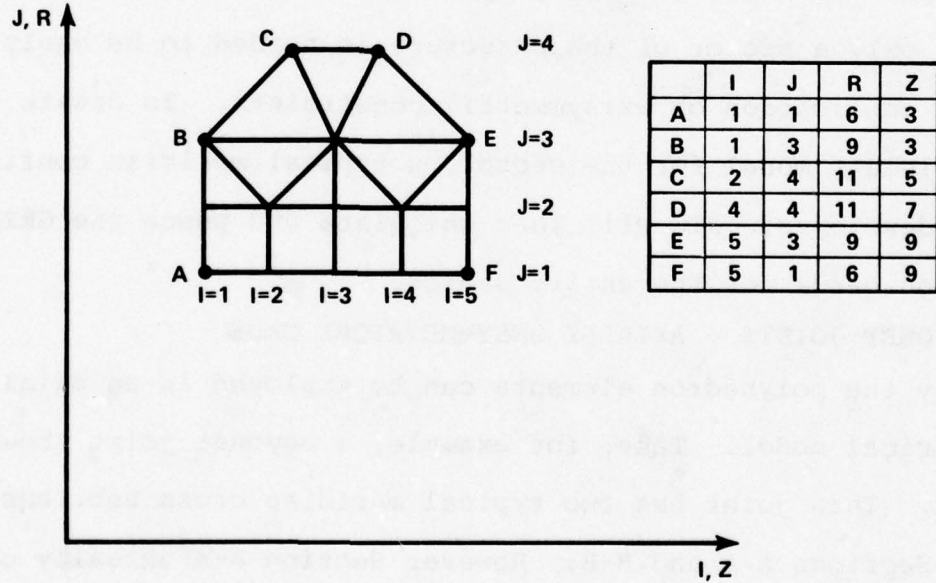

FIG. 3 MESH WITH TRANSITION FEATURE

$$R = R_0 + AZ + BZ^2 + CZ^3 + D \cos(EZ + F) \quad (1)$$

can be fitted to many practical shapes. In Figure 4 is shown a cross section resembling a nozzle. The curve between a and e has the parameters  $R_0 = 4.5$ ;  $A = -.375$ ;  $B = -.15$  and  $C = .025$  while that between e and d has  $R_0 = 5$ ;  $A = -1.35$ ;  $B = .18$  and  $C = -.006$ . The dots between a and d are plotted from an equation having  $R_0 = 4.5$ ;  $A = .5676$ ;  $B = -.1$ ;  $C = .0033$ ;  $D = 3.2517$ ;  $E = \pi/10$  and  $F = .5\pi$ . It can be seen that the dots follow closely to the curves therefore is an excellent alternative. Of course, if greater accuracy is desired, more control points may be employed between a and d.

The polyhedron element can also be used in the analysis of axisymmetric problems. However, the simpler ring element should always be used whenever possible. The polyhedron element which can be used with other elements such as the plate element, etc. is provided for the analysis of a junction model consisting of shell segments. However, only a sector of the structure is needed to be analyzed with the application of axisymmetric constraints. To create the finite element model for the sector, a typical meridian configuration must be developed. JIG will then calculate and punch the GRID and/or connection cards for the entire sector.

## 2.2 BAYONET JOINTS - AXIALLY UNSYMMETRICAL CASE

Only the polyhedron elements can be employed in an axially unsymmetrical model. Take, for example, a bayonet joint shown in Figure 5. This joint has two typical meridian cross sections as seen in Sections A-A and B-B. However Section A-A actually contains the configuration shown in Section B-B, therefore, only Section A-A is required in the development of the model. Figure 6 shows part

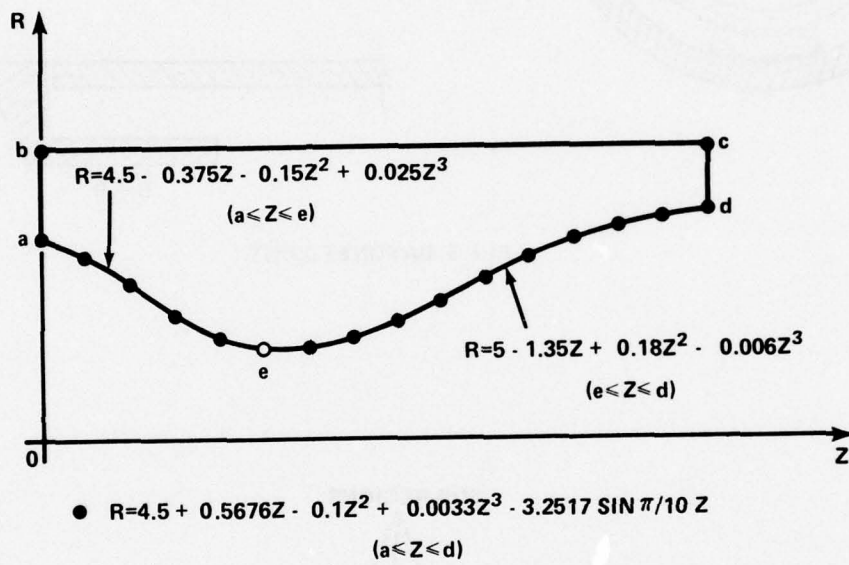

FIG. 4 NOZZLE CROSS SECTION, CURVED BOUNDARY

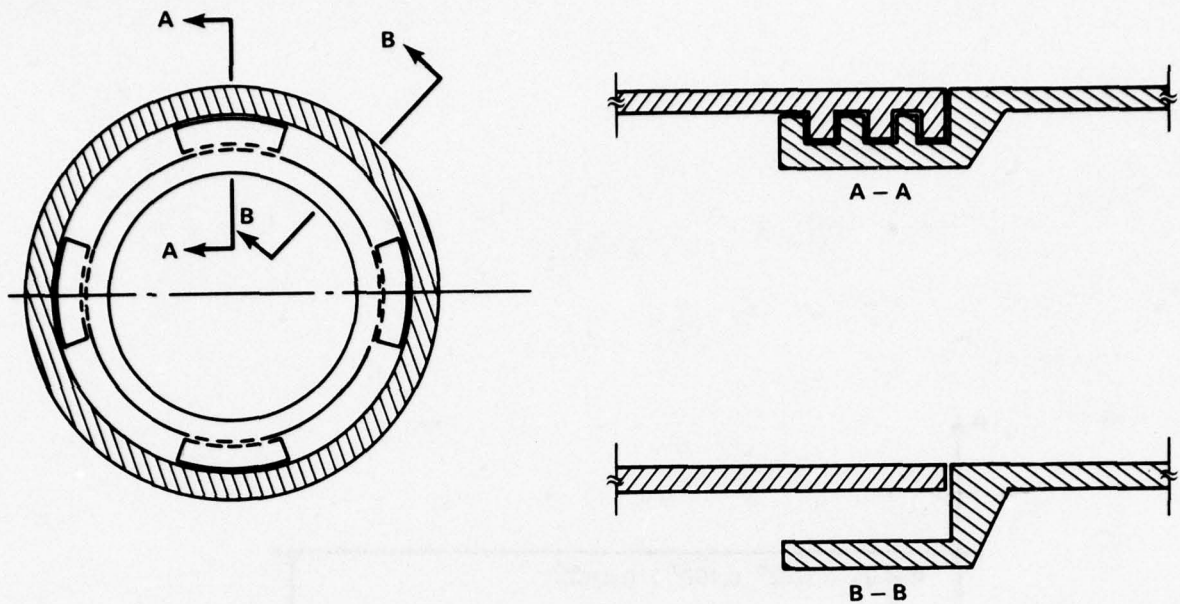

FIG. 5 BAYONET JOINT

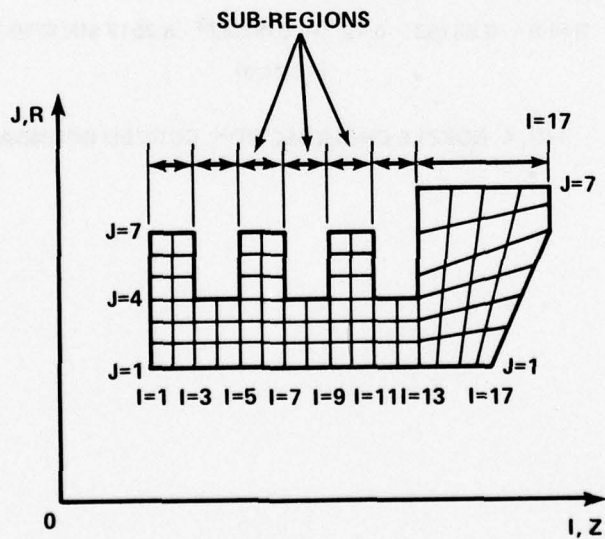

FIG. 6 MESH OF PART OF BAYONET JOINT

of the bayonet joint which will be developed by JIG. The mesh is divided into seven subregions in the Z direction. Each subregion requires the same types of input, therefore, the input cards become increasingly bulky with more subregions. JIG will generate the sector that Section A-A applies. For the next sector that Section B-B applies JIG simply ignores those elements which do not belong, i.e., elements from  $J = 4$  and above in subregions 1, 2, and 3. This cycle will be repeated until the joint is developed completely.

A demonstrative example can be found in Appendix B.

### 2.3 THREADED JOINTS

A threaded joint has a large number of teeth therefore a large number of subregions. To avoid inputting repeated data, a special provision to simplify input for repeated subregions is implemented so that the subsequent teeth can be generated from the input of a typical subregion as shown in Figure 7. This is done by a transformation process, therefore, every repeated subregion has an identical mesh with unique grid points. Then either the ring elements or the polyhedron elements will be connected to the grid points to form a finite element model.

### 2.4 JIG AND BING COUPLING

When the polyhedron elements are employed in the model, other NASTRAN elements can also be used in the same model. The common grid points that connect these two different elements must be constrained to achieve compatibility conditions. In missile structure the most common combination is the triaxial polyhedron elements together with the plate elements which are developed on thin plate theory. Take a shell-joint junction as an example, the finite element

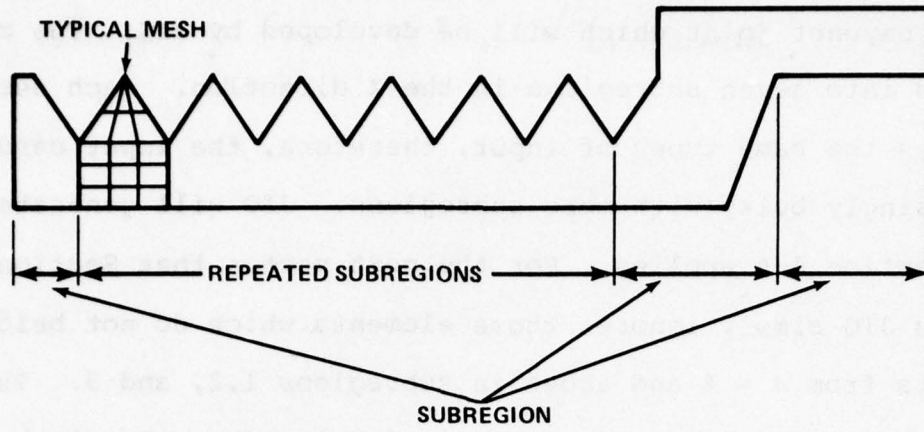

FIG. 7 THREADED JOINT

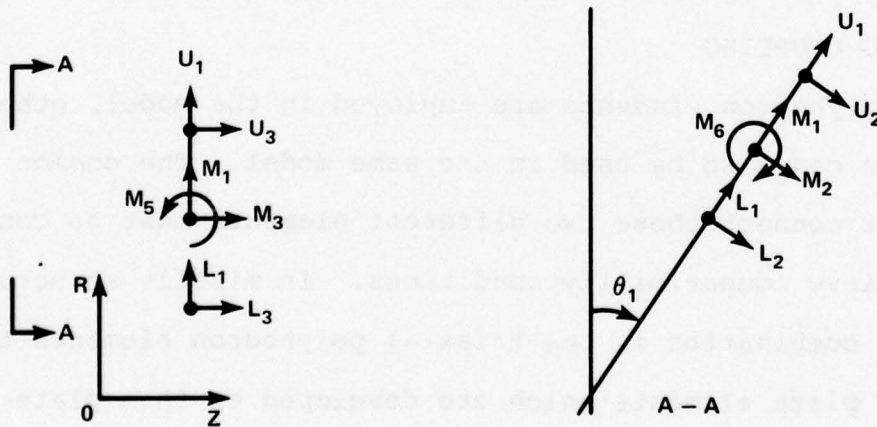
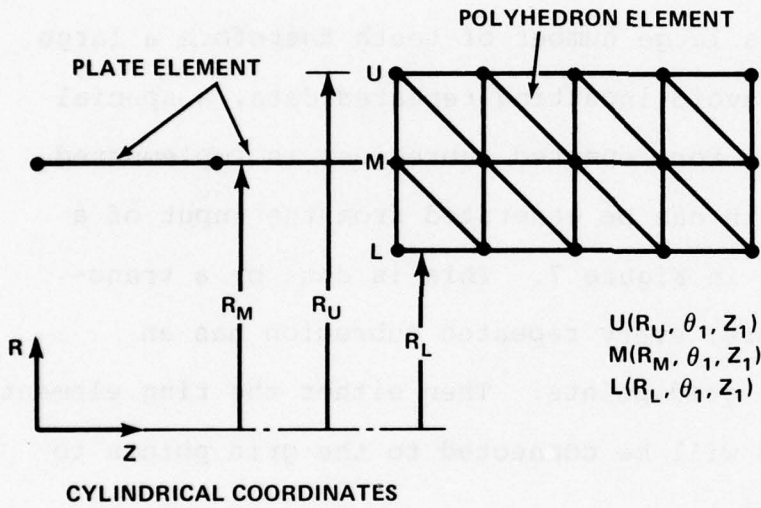

FIG. 8 JOINT-SHELL INTERFACE

model has polyhedron elements in the thick part and plate elements in the shell areas.

In Figure 8 is shown such a model, the plate elements representing the shell connect the polyhedron elements at a radius  $R_M$  where grid point M is located. U and L are the grid points above and below M respectively. All three points are located on a junction line along the intersection of  $\theta = \theta_1$  and  $Z = Z_1$  planes. The grid point M connecting a plate element has five degrees of freedom while U and L have only three degrees of freedom as shown in the figure. To insure shell-joint interactions the following constraints must be imposed.

$$U_1 = M_1 \quad (2)$$

$$U_2 = M_2 + (R_U - R_M)M_6 \quad (3)$$

$$U_3 = M_3 + (R_M - R_U)M_5 \quad (4)$$

$$L_1 = M_1 \quad (5)$$

$$L_2 = M_2 + (R_L - R_M)M_6 \quad (6)$$

$$L_3 = M_3 + (R_M - R_L)M_5 \quad (7)$$

Equation (2) through (7) can be input by means of Multipoint Constraints Cards (MPC). For every common grid point M JIG will automatically set up the six equations and punch out the MPC cards. The grid points to be used as M, L and U are JIG input and are specified by their (I, J) location.

There are three options which can be selected by the user; namely: left coupling, right coupling or couplings on both sides of the massive structure. In any case, BING must be employed to generate the shell part first, then JIG can proceed to create the joint part and the coupling. The grid point numbers of M where

couplings are desired must be input into the JIG and can be obtained from the BING model.

## 2.5 OTHER USEFUL FEATURES

Developed in BING are the following features which make possible the development of a complex finite element model for NASTRAN analysis. These capabilities are also retained in JIG for the same reason.

### 1. TRANSITION OF MESH SIZE

This feature has been shown in Figure 3 in which transitions are carried out in the J direction. The I and J directions must be oriented as indicated in the figure, i.e., I is directed along Z axis and J is directed in the R axis.

### 2. DISPLACEMENT OF POINTS AND LINES

Any points and/or lines can be placed at prescribed locations by means of this feature.

### 3. PRESCRIPTION OF GRID POINT NUMBER

To facilitate the joining of two structural components and eliminate the otherwise required Multipoint Constraints Cards (MPC) at the common grid points, this preprocessor has the provision for inputting pre-assigned numbers for any grid points.

### 4. CONTROL OF NUMBERING GRID POINTS, FINITE ELEMENTS AND CONTINUATION CARDS

This provision avoids duplication numbers in grid points, finite elements and continuation cards, especially with separate JIG runs. NASTRAN will reject any such duplicated numbers in the bulk data deck. To provide this capability the beginning numbers of these cards must be input and the last number used are tabulated

in the output of a JIG run so that in the subsequent run, proper beginning numbers can be selected.

Chapter 3  
USER'S MANUAL

JIG, written in FORTRAN, can generate the finite element model of a joint type junction and most of the bulk data cards required for NASTRAN application. This code is capable of generating an axisymmetric triangular cross section ring element (CTRIAG) or a three-dimensional solid, with three quadrilateral faces and two opposing triangular faces, (CWEDGE). The triangular membrane and bending element (CTRIA2) can also be generated for a two-dimensional problem. Table 2 list the different element punch options available.

This section presents card formats in sequential order which must be followed exactly when preparing the JIG input. There are 18 card types altogether, however, the number of card types to be used will vary depending on the type of problem encountered. The user should start from card type 1 and proceed through 19. Any card types to be omitted or put in more than once will be identified in the instruction.

Table 2  
JIG Element Punch Options

Punch	Type(s) of Connection Cards
0	CTRIA2 only
1	CTRIARG only
2	CTRIA2 and CTRIARG
3	CWEDGE only

3-1 FORMAT OF JIG CARD TYPES

CARD TYPE 1 - TITLE CARD

FORMAT (13A6)

Col.

1-78
ANY ALPHANUMERIC STATEMENT

1-8	2-10	1-12	12-20	21-25	26-30	31-35
NET	WGS	WLS	WDR	WHR	WIR	WJLT

DEFINITIONS

- NET = number of section types
- WGS = starting grid point number
- WLS = starting element number
- WDR = element punch option
- WHR = 0 punches CTRL-R cards only
- WIR = 1 punches CTRL-R cards only
- WJLT = 2 punches CTRL-R and CTRL-R
- WDR = 3 punches CTRL-R only
- MID = material identification number
- WGP = grid card punch option
- WGP = 0 grid cards punched
- WGP = 1 grid cards not punched
- WJLT = 0 axisymmetric ring element
- WJLT = 1 3-D solid (wedge) element
- WJLT = number of different cross-sections (for solid wedge only)

## CARD TYPE 2 - PROGRAM CONTROL CARD

FORMAT (8I5)

Col.

1-5	6-10	11-15	16-20	21-25	26-30	31-35	36-40
NST	NGS	NES	NPOP	MID	NGP	IDELT	NSECT

DEFINITIONS

- NST = number of section types
- NGS = starting grid point number
- NES = starting element number
- NPOP = element punch option  
 = 0 punches CTRLA2 cards only  
 = 1 punches CTRLARG cards only  
 = 2 punches CTRLA2 and CTRLARG  
 = 3 punches CWEDGE only
- MID = material identification number
- NGP = grid card punch option  
 = 0 grid cards punched  
 = 1 grid cards not punched
- IDELT = 0 axisymmetric ring element  
 = 1 3-D solid (wedge) element
- NSECT = number of different cross-sections  
 (for solid wedge only)

## CARD TYPE 3 - REPEATED

FORMAT (715)

Col.

1-5	6-10	11-15	16-20	21-25	26-30	31-35
NT(I)	NT(I+1)	NT(I+2)	NT(I+3)	NT(I+4)	NT(I+5)	NT(I+6)

DEFINITION

NT(I) = number of section type I

## CARD TYPE 4 - REPEATED SECTION DATA

FORMAT (7F10.4)

Col.

1-10	11-20	21-30	31-40	41-50
DELTZ (1)	DELTZ (I+1)	DELTZ (I+2)	DELTZ (I+3)	DELTZ (I+4)

Col.

51-60

61-70

DELTZ (I+5) DELTZ (I+6)

DEFINITION

DELTZ (I) = length of repeated section (Z-value)

(for NT(I) = 1, DELTZ (I) = 0.0)

## CARD TYPE 5 - THETA REGION DATA

NOTE: If IDELT = 0, do not input

FORMAT (315)

Col.

1-5	6-10	11-15
NDT	ICLOSE	DELGP

DEFINITIONS

NDT = number of different theta regions

ICLOSE = 0 full 360° segment

= 1 segment less than 360°

DELGP = element number to be added to original  
number for each theta section

CARD TYPE 6 - THETA REGION DATA

NOTE: If IDELT = 0, do not input

FORMAT (5(I5,F10.4))

Col.

1-5	6-15	16-20	21-30	...	61-65	66-75
KK(1)	THETA(1)	KK(2)	THETA(2)		KK(N)	THETA(N)

DEFINITIONS

KK(N) = integer used to determine  $\Delta\theta$ ,  
used in the following equation

$$\Delta\theta = \frac{\text{THETA}(I+1) - \text{THETA}(I)}{\text{KK}(I+1) - \text{KK}(I)}$$

THETA(N) = theta value at KK(N)

Example NDT = 2, ICLOSE = 1

KK(1) = 1, THETA(1) = 0.0°

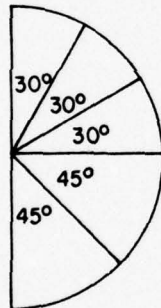

KK(2) = 4, THETA(2) = 90.0°

KK(3) = 6, THETA(3) = 180.0°

## CARD TYPE 7 - VARIABLE CROSS-SECTION DATA

NOTE: Input only if IDELT = 1

FORMAT (7F10.4)

Col.

1-10	11-20		...		61-70
BETA(1)	BETA(2)				BETA(N)

DEFINITION

BETA(N) - angles where change of cross-section occurs, (include initial and final angles of the joint)

NOTE: For constant cross-section (NSECT = 1) only input initial and final angle of joint.

## CARD TYPE 8 - VARIABLE CROSS-SECTION DATA

NOTE: Input only if IDELT = 1.

FORMAT (815)

Col.

1-5	6-10	11-15	16-20		...		31-35	36-40
JB(1)	JE(1)	JB(2)	JE(2)				JB(N)	JE(N)

DEFINITIONS

JB(N) - minimum J-value of mesh to be included in subsector N

JE(N) - maximum J-value of mesh to be included in subsector N

NOTE: For constant cross-section (NSECT = 1),

only input JMIN and JMAX for JB(1) and JE(1).

## CARD TYPE 9 - SECTION DATA

NOTE: Repeat card types 9 thru 15 NST times.

FORMAT (12I5)

Col.

1-5	6-10	11-15	16-20	21-25	26-30	31-35	36-40	41-45
NEBP	JMIN	JMAX	MINI	MAXI	NHO	NPO	NTR	JMINJ

Col.

46-50	51-55	56-60
JMAXJ	NPS	MPC

DEFINITIONS

NEBP = number of external boundary points to be input for section

JMIN = minimum J-value of section

JMAX = maximum J-value of section

MINI = minimum I-value of section

MAXI = maximum I-value of section

NHO = number of prescribed internal lines and points (i.e., for  
one line and one point, NHO = 2)

NPO = tooth code = 0 for flat tooth (or no tooth)  
= 1 for pointed tooth

NTR = number of transitions in section

JMINJ = minimum J-value of junction between sections

JMAXJ = maximum J-value of junction between sections

NOTE: If NST = 1 and NT(1) = 1, JMINJ = JMAXJ = 0

NPS = permanent single point constraint associated with grid points  
(any of the digits 1-6 with no imbedded blanks)

MPC = 0 MPC equations not punched  
= 1 MPC equations to be punched

CARD TYPE 10 - MPC DATA

NOTE: If MPC = 0, do not input.

FORMAT (I5)

Col.

1-5
NBO

DEFINITION

NBO = number of boundaries MPC equations are to be punched for  
 (= 1 or 2)

## CARD TYPE 11 - MPC DATA

NOTE: Input NBO cards (do not input if MPC = 0)

FORMAT (9I5)

Col.

1-5	6-10	11-15	16-20	21-25	26-30	31-35	36-40	41-45
IU(M)	JU(M)	MI(M)	JM(M)	IL(M)	LJ(M)	LS(M)	ICONST(M)	JCONST(M)

DEFINITIONS

IU(M), JU(M) = I, J Location of upper grid point  
in MPC equation

MI(M), JM(M) = I, J Location of middle grid point  
in MPC equation

IL(M), LJ(M) = I, J Location of lower grid point  
in MPC equation

LS(M) = Repeated section number for which  
the MPC equations are to be written  
(i.e., first or last; = 1 if section  
is not repeated)

ICONST(M) }  
JCONST(M) } = constant I or J for line of points given  
above (only one gets a value, the other  
is 0)

## CARD TYPE 12 - TOOTH POINT DATA

NOTE: Do not input if NPO = 0

FORMAT (I5, 2F10.5)

Col.

1-5	6-15	16-25
JP	ZP	XP

DEFINITIONS

JP = J-value of tooth point (=JMAX + 1)

ZP = Z-value of tooth point

XP = X- or R-value of tooth point

## CARD TYPE 13 - BOUNDARY POINTS

NOTE: Input (NEBP + 1)/2 cards

FORMAT (2I5, 2F10.5, 2I5, 2F10.5)

Col.

1-5	6-10	11-20	21-30	31-35	36-40	41-45	46-55	56-65	66-70
I1	J1	Z1	X1	IC1	I2	J2	Z2	X2	IC2

DEFINITIONS

In = value of I-line for point n

Jn = value of J-line for point n

Zn = Z coordinate of point n

Xn = X or R coordinate of point n

IC1 } = 1 straight line to next point

IC2 }

= 2 curved line to next point; card type

11A required

Order of card type 11A

If IC1 = 2 card type 11A follows

If IC2 = 2 card type 11A follows next  
card type 11

If IC2 = 2 in the last card type 11,  
card type 11A follows

## CARD TYPE 14 - CURVED BOUNDARY EQUATION

FORMAT (7F10.4)

Col.

1-10	11-20	21-30	31-40	41-50	51-60	61-70
RO	A	B	C	D	E	F

DEFINITIONS

RO

A

B

C

D

E

F

= Coefficients in the boundary expression  
for X(I,J) (or R(I,J))

$$X(I,J) = RO + A * Z(I,J) + B * Z(I,J)^2 + C * Z(I,J)^3 + D * \cos(E * Z(I,J) + F)$$
NOTE: Actual Z used in above expression

## CARD TYPE 15 - PRESCRIBED LINES AND POINTS DATA

NOTE: Do not input if NHO = 0

FORMAT (10I5)

Col.

1-5	6-10	...	46-50
NPH(1)	NPH(2)		NPH(N)

DEFINITIONS

NPH(N) = 1 for a fixed point  
 = 2 for a fixed line  
 (N = 1, NHO)

## CARD TYPE 16 - LOCATION OF PRESCRIBED POINTS AND LINES

**NOTE:** Input NHO cards

FORMAT (2I5, 2F10.5, 4I5, 2F10.5)

Col.

1-5	6-10	11-20	21-30	31-35	36-40	41-45	46-50	51-60	61-70
I1	J1	Z1	X1	NG1	IPO	I2	J2	Z2	X2

**DEFINITIONS**

In = value of I-line for point n

Jn = value of J-line for point n

Zn = Z coordinate of point n

Xn = X or R coordinate of point n

NG1 = fixed grid point number

= 0 for fixed Z and X location only

&gt; 0 for grid point numbers to go in

increasing order (only for a line)

&lt; 0 for grid point numbers to go in

decreasing order (only for a line)

IPO = grid card punch option

= 0 grid card not punched

= 1 grid card punched

**NOTE:** For fixed grid point numbers only

set X &lt; 0.0

CARD TYPE 17 - TRANSITION DATA

NOTE: Do not input if NTR = 0

FORMAT (I5)

Col.

1-5
-----

INTN
------

DEFINITION

INTN = a constant for the initial J-line to be determined by the following equation

$$2^{\text{INTN}} = I_{N+1} - I_N$$

$I_N$  = I-value of the initial J-line

## CARD TYPE 18 - TRANSITION DATA

NOTE: Input NTR cards

FORMAT (2I5)

Col.

1-5	6-10
JT(N)	NTNT(N)

DEFINITIONS

JT(N) = J-value at the end of the Nth transition

NTNT(N) = constant for JT(N) line to be determined

by the following equation:

$$2^{NTNT(I)} = I_{N+1} - I_N$$

$I_N$  = I-value of the Nth transition line

## CARD TYPE 19 - MPC CONSTRAINT DATA

NOTE: Input only if MPC = 1

FORMAT (10I5) Input NBO cards.

Col.

1-5	6-10	11-15	16-20	21-25	26-30	31-35	36-40	41-45	46-50
CZ	CN	CO	CT	CB	CZM	CNM	COM	CTM	CBM

DEFINITIONS

- upper and lower  
grid points
- CZ = Permanent single point constraints for  $\theta=0^\circ$
  - CN = Permanent single point constraints for  $\theta=90^\circ$
  - CO = Permanent single point constraints for  $\theta=180^\circ$
  - CT = Permanent single point constraints for  $\theta=270^\circ$
  - CB = Permanent single point constraints for all other  $\theta$ 's
- middle  
grid points
- CZM = Permanent single point constraints for  $\theta=0^\circ$
  - CNM = Permanent single point constraints for  $\theta=90^\circ$
  - COM = Permanent single point constraints for  $\theta=180^\circ$
  - CTM = Permanent single point constraints for  $\theta=270^\circ$
  - CBM = Permanent single point constraints for all other  $\theta$ 's

NSWC/WOL TR 77-85

APPENDIX A  
JIG FORTRAN LISTING

```

PROGRAM JIG(INPUT,OUTPUT,TAPE5=INPUT,TAPE6=OUTPUT,PUNCH)
C *** JUNCTION INPUT GENERATOR PROGRAM (JIG)
DIMENSION X(30,30),Z(30,30),NT(10),NG(30,30),DELTZ(10),CODE(30,30)
DIMENSION NGF(30,30),KSKIP(30,30),KK(10),THETA(10),JB(10),JE(10)
1,BETA(10),IMIN(30),IMAX(30),TITLE(13)
COMMON X,Z,NG,NGF,KSKIP,NSECT,JB,JE,BETA,THETA,IMIN,IMAX,JMAX
11,JMIN1
COMMON MPC,IU(2),JU(2),IM(2),JM(2),IL(2),JL(2),ICON,LS(2)
COMMON ICONST(2),JCONST(2)
INTEGER CODE
ICON = 1
PRINT 99
WRITE(6,800)
WRITE(6,800)
WRITE(6,801)
WRITE(6,802)
WRITE(6,801)
WRITE(6,800)
WRITE(6,800)
WRITE(6,803)
READ(5,500)(TITLE(I),I=1,13)
WRITE(6,501)(TITLE(I),I=1,13)
READ(5,302) NST,NGS,NES,NPOP,MID,NGP,IDELT,NSECT
WRITE(6,502) NST,NGS,NES,NPOP,MID,NGP,IDELT,NSECT
I=1
7 READ(5,302) NT(I),NT(I+1),NT(I+2),NT(I+3),NT(I+4),NT(I+5),NT(I+6)
READ(5,304) DELTZ(I),DELTZ(I+1),DELTZ(I+2),DELTZ(I+3),DELTZ(I+4),
1DELTZ(I+5),DELTZ(I+6)
I=I+7
IF(I.LT.NST) GO TO 7
DO 10 J=1,NST
10 WRITE(6,503) J,NT(J),J,DELTZ(J)
IF(IDELT.EQ.0) GO TO 3
READ(5,411) NDT,ICLOSE,DELGP
WRITE(6,504) NDT,ICLOSE,DELGP
IF=NDT+1
READ(5,410) (KK(J),THETA(J),J=1,IF)
DO 11 L=1,IF
11 WRITE(6,505) L,KK(L),L,THETA(L)
MAD = KK(NDT + 1) - 1
NS = NSECT + 1
READ(5,304) (BETA(LM),LM=1,NS)
DO 12 M=1,NS
12 WRITE(6,506) M,BETA(M)
READ(5,302) (JB(LN),JF(LN),LN=1,NSECT)
DO 13 N=1,NSECT
13 WRITE(6,507) N,JB(N),N,JE(N)
3 I=1
PRINT 99
DO 700 L=1,NST
NN=NT(I)
DO 600 LL=1,NN
CALL TOOTH(JMIN,JMAX,MINI,MAXI,NPC,NTR,JMINJ,JMAXJ,DELTZ,LL,L,NPS,
1IDELT,MAD)
CALL PUNCHR(JMIN,JMAX,MINI,MAXI,NPO,NT,NTR,L,JMINJ,JMAXJ,NGS
1,LL,NES,NPOP,MID,NGP,IDELT,NDT,ICLOSE,DELGP,KK,NPS)
600 CONTINUE
700 I=I+1
99 FORMAT(1H1)
302 FORMAT(8I5)
304 FORMAT(7F10.4)
410 FORMAT(5(I5,F10.4))
411 FORMAT(3I5)
500 FORMAT(13A6)

```

BUG

BUG

BUG

BUG

BUG

BUG

BUG

BUG

BUG

BUG

BUG

BUG

BUG

BUG

BUG

BUG

```

501 FORMAT(15X,13A6,/)
502 FORMAT(10X,6HNST = ,I5,/,10X,6HNCS = ,I5,/,10X,6HNES = ,I5,/,10X,7
1HNPOP = ,I5,/,10X,6HMID = ,I5,/,10X,6HNCP = ,I5,/,10X,8HIDELT = ,I
25,/,10X,8HNSFCT = ,I5)
503 FORMAT(10X,3HNT(,I2,4H) = ,I5,5X,6HDELTZ(,I2,4H) = ,F10.4)
504 FORMAT(10X,6HNDT = ,I5,/,10X,9HCLOSE = ,I5,/,10X,8HDELGP = ,I5)
505 FORMAT(10X,3HKK(,I2,4H) = ,I5,5X,6HTHETA(,I2,4H) = ,F10.4)
506 FORMAT(10X,5HBETA(,I2,4H) = ,F10.4)
507 FORMAT(10X,3HJ9(,I2,4H) = ,I5,5X,3HJE(,I2,4H) = ,I5)
800 FORMAT(35X,50H*****
801 FORMAT(35X,2H**,46X,2H**)
802 FORMAT(35X,2H**,3X,40HJUNCTION INPUT GENERATOR PROGRAM (JIG),
13X,2H**)
803 FORMAT(/////)
END
SUBROUTINE TOOTH(JMIN,JMAX,MINI,MAXI,NPO,NTR,JMINJ,JMAXJ,DELTZ,LL,
1L,NPS,IDELE,MAO)
DIMENSION X(30,30),Z(30,30),CODE(30,30),NPH(10),IMIN(30),IMAX(30)
DIMENSION NJ7(30),N7(30),NG(30,30),DELTZ(10),NGF(30,30),KSKIP(30,
130),JB(10),JE(10),BETA(10),THETA(10)
COMMON X,Z,NG,CODE,NGF,KSKIP,NSECT,JB,JE,BETA,THETA,IMIN,IMAX,JMAX
11,JMIN1
COMMON MPC,IU(2),JU(2),MI(2),JM(2),IL(2),LJ(2),ICON,LS(2)
COMMON ICONST(2),JCONST(2)
C *** THIS SUBROUTINE CALCULATES THE GRID POINT COORDINATES OF ANY
C *** SECTION.
INTEGER CODE
IF(LL.GT.1) GO TO 800
READ(5,10) NEBP,JMIN,JMAX,MINI,MAXI,NHO,NPO,NTR,JMINJ,JMAXJ,NPS,
1MPC
C***** INITIALIZE
JRAN = JMAX - JMIN + 1
IRAN = MAXI - MINI + 1
IRNN = IRAN + 1
JRNN = JRAN + 1
DO 20 J = 1,JRNN
DO 15 I = 1,IRNN
X(I,J) = 0.
Z(I,J) = 0.
NG(I,J)=0
NGF(I,J)=0
KSKIP(I,J)=0
15 CODE(I,J) = 0
IMIN(J) = 1000
20 IMAX(J) = 0
DO 21 I=1,30
NJ7(I)=0
N7(I)=0
21 CONTINUE
IF(MPC.EQ.0) GO TO 200
RFAD(5,49) NBC
DO 201 M=1,NBC
201 READ(5,49) IU(M),JU(M),MI(M),JM(M),IL(M),LJ(M),LS(M),ICONST(M),
1JCONST(M)
C***** READ EXTERNAL BOUNDARY NODAL POINT DATA
200 IF(NPO.EQ.0) GO TO 4
READ(5,26) JP,ZP,XP
CODE(1,JP)=1
Z(1,JP)=ZP
X(1,JP)=XP
4 NCC = 0
NB = (NEBP+1) / 2
NBC = 2 * NB
DO 17 N = 1,NB

```

BUG

TOOTH

TOOTH

TOOTH

TOOTH

TOOTH

TOOTH

TOOTH

TOOTH

TOOTH

TOOTH

TOOTH

TOOTH

TOOTH

TOOTH

TOOTH

TOOTH

TOOTH

TOOTH

TOOTH

TOOTH

TOOTH

TOOTH

TOOTH

TOOTH

TOOTH

TOOTH

TOOTH

TOOTH

TOOTH

TOOTH

TOOTH

TOOTH

TOOTH

TOOTH

TOOTH

TOOTH

TOOTH

TOOTH

TOOTH



```

14 CONTINUE
NCC = 1
GO TO 309
9 NSTEPS = MAX0(IABS(LI-I2), IABS(JL-J2))
ISTEP = (LI-I2) / NSTEPS
JSTEP = (JL-J2) / NSTEPS
DD = NSTEPS
IF(IC2.EQ.2) READ(5,302) R0,A,B,C,D,E,F
DZ=(ZL-Z2)/DD
DX=(XL-X2)/DD
DO 11 NST = 1, NSTEPS
I = I2 + ISTEP * NST
J = J2 + JSTEP * NST
IF(CODE(I,J).EQ.1) GO TO 11
Z(I,J)=Z(I-ISTEP,J-JSTEP) + DZ
IF(IC2.EQ.2) GO TO 305
X(I,J) = X(I-ISTEP,J-JSTEP) + DX
GO TO 306
305 X(I,J) = R0 + A*Z(I,J) + B*Z(I,J)*Z(I,J) + C*Z(I,J)*Z(I,J)*Z(I,J)
1 + D*COS(F*Z(I,J) + F)
306 CODE(I,J) = 1
11 CONTINUE
GO TO 309
12 IF(IC1.EQ.2) READ(5,302) R0,A,B,C,D,E,F
NSTEPS = MAX0(IABS(I2-I1), IABS(J2-J1))
ISTEP = (I2-I1) / NSTEPS
JSTEP = (J2-J1) / NSTEPS
DD = NSTEPS
DZ=(Z2-Z1)/DD
DX=(X2-X1)/DD
DO 18 NST = 1, NSTEPS
I = I1 + ISTEP * NST
J = J1 + JSTEP * NST
IF(CODE(I,J).EQ.1) GO TO 18
Z(I,J)=Z(I-ISTEP,J-JSTEP) + DZ
IF(IC1.EQ.2) GO TO 303
X(I,J) = X(I-ISTEP,J-JSTEP) + DX
GO TO 304
303 X(I,J) = R0 + A*Z(I,J) + B*Z(I,J)*Z(I,J) + C*Z(I,J)*Z(I,J)*Z(I,J)
1 + D*COS(E*Z(I,J) + F)
304 CODE(I,J) = 1
18 CONTINUE
17 CONTINUE
C***** READ INTERNAL BOUNDARY NODAL POINT DATA
IF(NHO.EQ.0) GO TO 53
READ(5,49) (NPH(N), N=1, NHO)
DO 52 N = 1, NHO
NCC = 0
NB = (NPH(N) + 1) / 2
NBC = 2 * NB
DO 50 N9 = 1, NB
NG1=0
READ(5,27) I1,J1,Z1,X1,NG1,IPO,I2,J2,Z2,X2
IF(NPH(N).EQ.2) GO TO 22
IF(NG1.NE.0) GO TO 101
GO TO 88
101 NG(I1,J1)=NG1
NGF(I1,J1)=NG1
IF(IPO.EQ.0) KSKIP(I1,J1) = -1
GO TO 88
22 IF(NG1.LT.0) GO TO 102
IF(NG1.EQ.0) GO TO 88
IF(I2.EQ.I1) GO TO 72
DO 71 M=I1,I2

```

NG(M,J1)=NG1	TOOTH
NGF(M,J1) = I2 + NG1 - I1	TOOTH
KSKIP(M,J1) = I2-I1	TOOTH
IF(IPO.EQ.0) KSKIP(M,J1)=-1*KSKIP(M,J1)	TOOTH
IF(IDELT.EQ.1) NG1 = NG1 + MAD	
71 NG1=NG1+1	TOOTH
GO TO 88	TOOTH
72 DO 73 M=J1,J2	TOOTH
NG(I1,M)=NG1	TOOTH
NGF(I1,M)=J2 + NG1 - J1	TOOTH
KSKIP(I1,M)=J2-J1	TOOTH
IF(IPO.EQ.0) KSKIP(I1,M)=-1*KSKIP(I1,M)	TOOTH
IF(IDELT.EQ.1) NG1 = NG1 + MAD	
73 NG1=NG1+1	TOOTH
GO TO 88	TOOTH
102 IF(I2.EQ.I1) GO TO 104	TOOTH
DO 105 M=I1,I2	TOOTH
NG(M,J1) = (-1)*NG1	TOOTH
NGF(M,J1)=I2-I1+NG1	TOOTH
KSKIP(M,J1) = I2-I1	TOOTH
IF(IPO.EQ.0) KSKIP(M,J1)=-1*KSKIP(M,J1)	TOOTH
IF(IDFLT.EQ.1) NG1 = NG1 + MAD	
105 NG1=NG1+1	TOOTH
GO TO 88	TOOTH
104 DO 106 M=J1,J2	TOOTH
NG(I1,M) = (-1)*NG1	TOOTH
NGF(I1,M)=J2-J1+NG1	TOOTH
KSKIP(I1,M)=J2-J1	TOOTH
IF(IPO.EQ.0) KSKIP(I1,M)=-1*KSKIP(I1,M)	TOOTH
IF(IDFLT.EQ.1) NG1 = NG1 + MAD	
106 NG1=NG1+1	TOOTH
88 IF(X1.LT.0.0) GO TO 50	
IF(NB.EQ.1) GO TO 30	TOOTH
GO TO 35	TOOTH
30 IF(NBC.EQ.NPH(N)) GO TO 32	TOOTH
CODE(I1,J1) = 2	TOOTH
Z(I1,J1)=Z1	TOOTH
X(I1,J1) = X1	TOOTH
GO TO 50	TOOTH
32 IF(CODE(I1,J1).EQ.1) GO TO 80	TOOTH
CODE(I1,J1) = 2	TOOTH
80 IF(CODE(I2,J2).EQ.1) GO TO 81	TOOTH
CODE(I2,J2) = 2	TOOTH
81 CONTINUE	TOOTH
Z(I1,J1) = Z1	TOOTH
X(I1,J1) = X1	TOOTH
Z(I2,J2) = Z2	TOOTH
X(I2,J2) = X2	TOOTH
NSTEPS = MAX0(IABS(I2-I1), IABS(J2-J1) )	TOOTH
ISTEP = (I2-I1) /NSTEPS	TOOTH
JSTEP = (J2-J1) /NSTEPS	TOOTH
DD = NSTEPS	TOOTH
DZ = (Z2-Z1)/DD	TOOTH
DX = (X2-X1) /DD	TOOTH
DO 33 NST = 1, NSTEPS	TOOTH
I = I1 + ISTEP *NST	TOOTH
J = J1 + JSTEP *NST	TOOTH
Z(I,J)=Z(I-ISTEP,J-JSTEP) + DZ	TOOTH
X(I,J) = X(I-ISTEP,J-JSTEP) + DX	TOOTH
IF(CODE(I,J).EQ.1) GO TO 33	TOOTH
CODE(I,J) = 2	TOOTH
33 CONTINUE	TOOTH
GO TO 50	TOOTH
35 IF(N9.EQ.1) GO TO 36	TOOTH

IF(N9.EQ.N9) GO TO 37	TOOTH
38 NSTEPS = MAX0(IABS(I1-IF), IABS(J1-JF) )	TOOTH
ISTEP = (I1-IF) /NSTEPS	TOOTH
JSTEP = (J1-JF) /NSTEPS	TOOTH
DD = NSTEPS	TOOTH
DZ=(Z1-ZF)/DD	TOOTH
DX = (X1-XF) /DD	TOOTH
DO 39 NST = 1, NSTEPS	TOOTH
I = IF +ISTEP *NST	TOOTH
J = JF + JSTEP *NST	TOOTH
Z(I,J)=Z(I-ISTEP,J-JSTEP) + DZ	TOOTH
X(I,J) = X(I-ISTEP,J-JSTEP) +DX	TOOTH
IF(CODE(I,J).EQ.1) GO TO 39	TOOTH
CODE(I,J) = 2	TOOTH
39 CONTINUE	TOOTH
IF(NCC.EQ.1) GO TO 50	TOOTH
ZF=Z2	TOOTH
XF = X2	TOOTH
IF = I2	TOOTH
JF = J2	TOOTH
GO TO 32	TOOTH
36 XL = X1	TOOTH
ZL=Z1	TOOTH
XF = X2	TOOTH
ZF=Z2	TOOTH
LI = I1	TOOTH
JL = J1	TOOTH
IF = I2	TOOTH
JF = J2	TOOTH
GO TO 32	TOOTH
37 IF(NBC.EQ.NPH(N) ) GO TO 40	TOOTH
NSTEPS = MAX0(IABS(LI-I1), IABS(JL-J1) )	TOOTH
ISTEP = (LI-I1) /NSTEPS	TOOTH
JSTEP = (JL-J1) /NSTEPS	TOOTH
DD = NSTEPS	TOOTH
DZ=(ZL-Z1)/DD	TOOTH
DX = (XL-X1) /DD	TOOTH
DO 42 NST = 1, NSTEPS	TOOTH
I = I1 + ISTEP *NST	TOOTH
J = J1 + JSTEP *NST	TOOTH
Z(I,J)=Z(I-ISTEP,J-JSTEP) + DZ	TOOTH
X(I,J) = X(I-ISTEP,J-JSTEP) + DX	TOOTH
IF(CODE(I,J).EQ.1) GO TO 42	TOOTH
CODE(I,J) = 2	TOOTH
42 CONTINUE	TOOTH
NCC = 1	TOOTH
GO TO 38	TOOTH
40 NSTEPS = MAX0(IABS(LI-I2), IABS(JL-J2) )	TOOTH
ISTEP = (LI-I2) /NSTEPS	TOOTH
JSTEP = (JL-J2) /NSTEPS	TOOTH
DD = NSTEPS	TOOTH
DZ=(ZL-Z2)/DD	TOOTH
DX = (XL-X2) /DD	TOOTH
DO 44 NST = 1, NSTEPS	TOOTH
I = I2 + ISTEP *NST	TOOTH
J = J2 + JSTEP *NST	TOOTH
Z(I,J)=Z(I-ISTEP,J-JSTEP) + DZ	TOOTH
X(I,J) = X(I-ISTEP,J-JSTEP) + DX	TOOTH
IF(CODE(I,J).EQ.1) GO TO 44	TOOTH
CODE(I,J) = 2	TOOTH
44 CONTINUE	TOOTH
GO TO 38	TOOTH
50 CONTINUE	TOOTH
52 CONTINUE	TOOTH



```

DX = (X(IN,J+1)+X(IM,J-1)+X(I+1,J)+X(I-1,J))/4.-X(I,J)
Z(I,J) = Z(I,J) + 1.8*DZ
X(I,J) = X(I,J) + 1.8*DX
RESID = RFSID + ABS(DX) + ABS(DZ)
70 CONTINUE
IF(N.EQ.1) RFS1 = RESID
IF(RES1.EQ.0.0) GO TO 800
IF(RESID/RES1.LT.1.E-5) GO TO 800
75 CONTINUE
800 CONTINUE
IF(JRAN.LE.2) GO TO 110
GO TO 115
110 IMIN(1) = IMIN(2) = MINI
IMAX(1) = IMAX(2) = MAXI
115 IF(LL.EQ.1) GO TO 92
I=MINI
90 CONTINUE
J=JMIN
91 CONTINUE
Z(I,J)=Z(I,J)+DELTZ(L)
J=J+1
IF(J.LE.JMAX) GOTO 91
I=I+1
IF(I.LE.MAXI) GOTO 90
IF(NPO.EQ.0) GO TO 82
Z(I,JP)=Z(I,JP) + DELTZ(L)
92 CONTINUE
82 WRITE(6,99)
99 FORMAT(///,9X,1HI,4X,1HJ,5X,6HZ(I,J),6X,6HX(I,J),2X,9HCODE(I,J),/)
DO 85 J=JMIN,JMAX
IB = IMIN(J)
IE = IMAX(J)
DO 86 I=IB,IE
WRITE(6,100) I,J,Z(I,J),X(I,J),CODE(I,J)
100 FORMAT(5X,2I5,2F12.5,I5)
86 CONTINUE
85 CONTINUE
IF(NPO.EQ.0) GO TO 45
I=1
WRITE(6,100) I,JP,Z(I,JP),X(I,JP),CODE(I,JP)
45 CONTINUE
10 FORMAT(12I5)
25 FORMAT(2I5,2F10.5,3I5,2F10.5,I5)
26 FORMAT(I5,2F10.5)
27 FORMAT(2I5,2F10.5,4I5,2F10.5)
49 FORMAT(10I5)
302 FORMAT(7F10.4)
RETURN
END
SUBROUTINE PUNCHR(JMIN,JMAX,MINI,MAXI,NPO,NT,NTR,L,JMINJ,JMAX
1J,NGS,LL,NFS,NPOP,MID,NGP,IDELT,NDT,ICLOSE,DELGP,KK,NPS)
DIMENSION X(30,30),Z(30,30),JT(10),NTNT(10),NT(10),NG(30,30)
DIMENSION NCG(1,30),CODE(30,30),NGF(30,30),KSKIP(30,30)
DIMENSION KK(10),THETA(10),JB(10),JE(10),BETA(10),IMIN(30),IMAX(30)
1)
COMMON X,Z,NG,CODE,NGF,KSKIP,NSECT,JB,JE,BETA,THETA,IMIN,IMAX,JMAX
11,JMIN1
COMMON MPC,IU(?),JU(2),IM(2),JM(2),IL(2),JL(2),ICON,LS(2)
COMMON ICONST(2),JCONST(2)
INTFGER DFLGP,G1,G2,G3
) *** THIS SUBROUTINE PUNCHES GRID CARDS AND ELEMENT CONNECTION CARDS
) *** (CTRIA2 AND CTRIARG).
NCALL = 0
NCP=0

```



```

IF(NGF(I,J).NE.0) GO TO 55
NG(I,J)=NGS
NGS=NGS+1
IF(IDFLT.EQ.1) NGS = NGS+ MAD
IF(ICLOSE.EQ.0.AND.IDELT.EQ.1) NGS = NGS - 1
NGLAST=NGS
GO TO 20
55 IF(KSKIP(I,J).LT.0.AND.LL.EQ.1) GO TO 42
IF(LL.EQ.1) GO TO 20
NG(I,J) = IABS(NGF(I,J)+1)
IF(IDFLT.EQ.1.AND.NGF(I,J).LT.0) NG(I,J) = NG(I,J) - 1 - MAD
IF(IDFLT.EQ.1.AND.NGF(I,J).GT.0) NG(I,J) = NG(I,J) + 1 + MAD
NGF(I,J) = IABS(KSKIP(I,J)) + NGF(I,J) + 1
IF(IDELT.EQ.1) NGF(I,J) = NGF(I,J) + MAD + 1
IF(KSKIP(I,J).LT.0) GO TO 43
20 IF(I.EQ.MINI.AND.LSTEP.EQ.1) GO TO 50
GO TO 51
50 IF(J.LE.JMAXJ1.AND.J.GE.JMINJ) GO TO 43
51 IF(J.EQ.1) GO TO 411
IF(I.LT.IMIN(J-1).OR.I.GT.IMAX(J-1)) GO TO 411
IF(ABS(X(I,J-1)).EQ.0.0.AND.ABS(X(I,J)).NE.0.0) Z(I,J) = Z(I,J-1)
411 IF(I.EQ.1) GO TO 410
IF(I-ISKIP.LT.IMIN(J)) GO TO 410
IF(ABS(X(I-ISKIP,J)).EQ.0.0.AND.ABS(X(I,J)).NE.0.0) Z(I,J) = Z(I-I
1SKIP,J)
410 IF(NGP.EQ.1) GO TO 43
IF(IDFLT.EQ.1) GO TO 101
IF(NPS.GT.0) GO TO 70
PUNCH 910,NG(I,J),NCP,X(I,J),Y,Z(I,J),NCD
WRITE(6,911) NG(I,J),NCP,X(I,J),Y,Z(I,J),NCD
GO TO 43
70 PUNCH 900,NG(I,J),NCP,X(I,J),Y,Z(I,J),NCD,NPS
WRITE(6,901) NG(I,J),NCP,X(I,J),Y,Z(I,J),NCD,NPS
GO TO 43
101 II=1
JJ = 1
TH1 = THETA(II)
102 IF(TH1.GE.BETA(JJ).AND.TH1.LE.BETA(JJ+1)) GO TO 600
JJ = JJ+1
600 IF(TH1.EQ.BETA(NSFCT+1)) GO TO 605
IF(TH1.EQ.BETA(JJ+1)) GO TO 602
IF(TH1.EQ.BETA(JJ)) GO TO 602
605 IF(J.LT.JB(JJ).OR.J.GT.JE(JJ)) GO TO 601
IF(J.EQ.JB(JJ).AND.J.EQ.JMAX) GO TO 601
602 IF(MPC.EQ.1) GO TO 608
IF(NPS.GT.0) GO TO 73
GO TO 609
608 IF(LS(1).EQ.LS(2)) GO TO 700
IF(LS(1).EQ.LL) GO TO 610
IF(LS(2).EQ.LL) GO TO 611
GO TO 609
700 IF(I.EQ.ICONST(1).OR.J.EQ.JCONST(1)) ML = 1
IF(I.EQ.ICONST(2).OR.J.EQ.JCONST(2)) ML = 2
GO TO 612
610 ML=1
GO TO 612
611 ML=?
612 IF(I.EQ.IU(ML).AND.J.EQ.JU(ML)) GO TO 650
IF(I.EQ.IM(ML).AND.J.EQ.JM(ML)) GO TO 650
IF(I.EQ.IL(ML).AND.J.EQ.JL(ML)) GO TO 650
IF(ML.EQ.2) GO TO 701
IF(IFIX1.EQ.3) GO TO 350
GO TO 351
701 IF(IFIX2.EQ.3) GO TO 704

```

PUNCHR  
PUNCHR  
PUNCHR

PUNCHR  
PUNCHR  
PUNCHR  
PUNCHR

PUNCHR

PUNCHR  
PUNCHR

```

GO TO 351
350 IFIX1 = 4
CALL MPCP(ML,NCALL,I,J,NDT,KK,IFIX1,MAXI,JMAX)
GO TO 660
704 IFIX2 = 4
CALL MPCP(ML,NCALL,I,J,NDT,KK,IFIX2,MAXI,JMAX)
GO TO 660
351 IF(NPS.GT.0) GO TO 73
GO TO 609
650 IF(ML.EQ.2) GO TO 702
IFIX1 = IFIX1 + 1
CALL MPCP(ML,NCALL,I,J,NDT,KK,IFIX1,MAXI,JMAX)
GO TO 660
702 IFIX2 = IFIX2 + 1
CALL MPCP(ML,NCALL,I,J,NDT,KK,IFIX2,MAXI,JMAX)
660 ICALL= 1
IF(ML.EQ.2) GO TO 708
IF(IFIX1.EQ.4) GO TO 351
GO TO 601
708 IF(IFIX2.EQ.4) GO TO 351
GO TO 601
609 PUNCH 910,NG(I,J),NCP1,X(I,J),TH1,Z(I,J),NCP1
WRITE(6,911) NG(I,J),NCP1,X(I,J),TH1,Z(I,J),NCP1
GO TO 601
73 PUNCH 900,NG(I,J),NCP1,X(I,J),TH1,Z(I,J),NCP1,NPS
WRITE(6,901) NG(I,J),NCP1,X(I,J),TH1,Z(I,J),NCP1,NPS
601 IF(TH1.EQ.THETA(II+1)) II=II+1
IF(ABS(TH1-THETA(NDT+1)).LT.0.001) GO TO 42
DTHETA = (THETA(II+1)-THETA(II))/(KK(II+1)-KK(II))
IF(ML.EQ.2) GO TO 706
IF(ICALL.EQ.1.AND.IFIX1.NE.4) GO TO 43
GO TO 707
706 IF(ICALL.EQ.1.AND.IFIX2.NE.4) GO TO 43
707 NG(I,J)=NG(I,J)+ 1
TH1 = TH1 + DTHETA
IF(TH1.EQ.360.0) GO TO 42
GO TO 102
42 IF(KSKIP(I,J).LT.0) GO TO 43
IF(IDFLT.EQ.1) NG(I,J) = NG(I,J) - (KK(NDT+1) - 1)
43 IF(J.EQ.JMIN) GO TO 150
IF(I.LE.IMIN(J)) GO TO 150
IF(I.GT.IMAX(J)) GO TO 150
IF(I.EQ.MINI) GO TO 150
IF(K.EQ.1) GO TO 6
IF(NTR.EQ.0) GO TO 6
IF(K-1.GT.NTR) GO TO 6
IF(J.EQ.JT(K-1)) GO TO 30
6 CONTINUE
IF(IDFLT.EQ.1) GO TO 500
IF(ABS(X(I-ISKIP,J-1)).EQ.0.0) GO TO 300
IF(NPOP.EQ.1) GO TO 80
PUNCH 902,IEID,IPID,NG(I,J),NG(I-ISKIP,J),NG(I-ISKIP,J-1),TH
WRITE(6,903) IEID,IPID,NG(I,J),NG(I-ISKIP,J),NG(I-ISKIP,J-1),TH
IF(NPOP.EQ.0) GO TO 90
80 PUNCH 904,IEID,NG(I,J),NG(I-ISKIP,J),NG(I-ISKIP,J-1),TH,MID
WRITE(6,905) IEID,NG(I,J),NG(I-ISKIP,J),NG(I-ISKIP,J-1),TH,MID
GO TO 90
500 G3 = NG(I-ISKIP,J-1)
G2 = NG(I-ISKIP,J)
G1 = NG(I,J)
IF(G3.EQ.0) GO TO 150
IF(NG(I,J-1).EQ.0) GO TO 150
CALL WEDGE(G1,G2,G3,DFLGP,KK,MID,IEID,ICLOSE,NDT,NPOP,J)
90 IEID = IEID + 1

```

PUNCHR  
PUNCHR  
PUNCHR  
PUNCHR  
PUNCHR

PUNCHR  
PUNCHR  
PUNCHR  
PUNCHR  
PUNCHR

PUNCHR

```

IF (IDELT.EQ.1) GO TO 501
IF (NPOP.EQ.1) GO TO 81
PUNCH 902, IEID, IPID, NG(I-ISKIP, J-1), NG(I, J-1), NG(I, J), TH
WRITE (6, 903) IEID, IPID, NG(I-ISKIP, J-1), NG(I, J-1), NG(I, J), TH
IF (NPOP.EQ.0) GO TO 91
81 PUNCH 904, IEID, NG(I-ISKIP, J-1), NG(I, J-1), NG(I, J), TH, MID
WRITE (6, 905) IEID, NG(I-ISKIP, J-1), NG(I, J-1), NG(I, J), TH, MID
GO TO 91
501 G3 = NG(I, J)
G2 = NG(I, J-1)
G1 = NG(I-ISKIP, J-1)
CALL WEDGE (G1, G2, G3, DFLGP, KK, MID, IEID, ICLOSE, NDT, NPOP, J)
91 IEID = IEID + 1
GO TO 150
300 IF (ABS(X(I, J-1)).EQ.0.0) GO TO 310
IF (NPOP.EQ.1) GO TO 301
PUNCH 906, IEID, IPID, NG(I-ISKIP, J-1), NG(I, J-1), NG(I, J), NG(I-ISKIP, J
1), TH
WRITE (6, 907) IEID, IPID, NG(I-ISKIP, J-1), NG(I, J-1), NG(I, J), NG(I-ISKI
P, J), TH
IF (NPOP.EQ.0) GO TO 302
301 PUNCH 908, IEID, NG(I-ISKIP, J-1), NG(I, J-1), NG(I, J), NG(I-ISKIP, J), TH,
1MID
WRITE (6, 909) IEID, NG(I-ISKIP, J-1), NG(I, J-1), NG(I, J), NG(I-ISKIP, J),
1TH, MID
302 IEID = IEID + 1
GO TO 150
310 IF (NPOP.EQ.1) GO TO 311
PUNCH 906, IEID, IPID, NG(I, J-1), NG(I, J), NG(I-ISKIP, J), NG(I-ISKIP, J-1
1), TH
WRITE (6, 907) IEID, IPID, NG(I, J-1), NG(I, J), NG(I-ISKIP, J), NG(I-ISKIP,
1J-1), TH
IF (NPOP.EQ.0) GO TO 312
311 PUNCH 908, IEID, NG(I, J-1), NG(I, J), NG(I-ISKIP, J), NG(I-ISKIP, J-1), TH,
1MID
WRITE (6, 909) IEID, NG(I, J-1), NG(I, J), NG(I-ISKIP, J), NG(I-ISKIP, J-1),
1TH, MID
312 IEID = IEID + 1
320 CONTINUE
330 CONTINUE
GO TO 150
30 IF (K-1.EQ.1) GO TO 21
IF (NTNT(K-1).GT.NTNT(K-2)) GO TO 22
IF (NTNT(K-1).LT.NTNT(K-2)) ISKIP1=ISKIP*2
IF (NG(I, J-1).EQ.0) GO TO 150
26 IF (IDELT.EQ.1) GO TO 502
IF (NPOP.EQ.1) GO TO 82
PUNCH 902, IEID, IPID, NG(I-ISKIP, J), NG(I-2*ISKIP, J), NG(I-ISKIP1, J-1)
1, TH
WRITE (6, 903) IEID, IPID, NG(I-ISKIP, J), NG(I-2*ISKIP, J), NG(I-ISKIP1, J
1-1), TH
IF (NPOP.EQ.0) GO TO 92
82 PUNCH 904, IEID, NG(I-ISKIP, J), NG(I-2*ISKIP, J), NG(I-ISKIP1, J-1), TH,
1MID
WRITE (6, 905) IEID, NG(I-ISKIP, J), NG(I-2*ISKIP, J), NG(I-ISKIP1, J-1),
1TH, MID
GO TO 92
502 G3 = NG(I-ISKIP1, J-1)
G2 = NG(I-2*ISKIP, J)
G1 = NG(I-ISKIP, J)
IF (G3.EQ.0) GO TO 150
IF (NG(I, J-1).EQ.0) GO TO 150
CALL WEDGE (G1, G2, G3, DELGP, KK, MID, IEID, ICLOSE, NDT, NPOP, J)
92 IEID = IEID + 1

```

PUNCHR  
PUNCHR  
PUNCHR  
PUNCHR  
PUNCHR

PUNCHR

PUNCHR  
PUNCHR  
PUNCHR  
PUNCHR

PUNCHR  
PUNCHR

PUNCHR  
PUNCHR  
PUNCHR  
PUNCHR

PUNCHR

```

IF(IDFLT.EQ.1) GO TO 503
IF(NPOP.EQ.1) GO TO 83
PUNCH 902,IFID,IPID,NG(I-ISKIP1,J-1),NG(I,J-1),NG(I-ISKIP,J),TH
WRITE(6,903) IFID,IPID,NG(I-ISKIP1,J-1),NG(I,J-1),NG(I-ISKIP,J),TH
IF(NPOP.EQ.0) GO TO 93
83 PUNCH 904,IEID,NG(I-ISKIP1,J-1),NG(I,J-1),NG(I-ISKIP,J),TH,MID
WRITE(6,905) IFID,NG(I-ISKIP1,J-1),NG(I,J-1),NG(I-ISKIP,J),TH,MID
GO TO 93
503 G3 = NG(I-ISKIP,J)
G2 = NG(I,J-1)
G1 = NG(I-ISKIP1,J-1)
CALL WEDGE(G1,G2,G3,DELGP,KK,MID,IEID,ICLOSE,NDT,NPOP,J)
93 IEID = IEID+1
IF(IDFLT.EQ.1) GO TO 504
IF(NPOP.EQ.1) GO TO 84
PUNCH 902,IEID,IPID,NG(I,J-1),NG(I,J),NG(I-ISKIP,J),TH
WRITE(6,903) IFID,IPID,NG(I,J-1),NG(I,J),NG(I-ISKIP,J),TH
IF(NPOP.EQ.0) GO TO 94
84 PUNCH 904,IEID,NG(I,J-1),NG(I,J),NG(I-ISKIP,J),TH,MID
WRITE(6,905) IFID,NG(I,J-1),NG(I,J),NG(I-ISKIP,J),TH,MID
GO TO 94
504 G3 = NG(I-ISKIP,J)
G2 = NG(I,J)
G1 = NG(I,J-1)
CALL WEDGE(G1,G2,G3,DELGP,KK,MID,IEID,ICLOSE,NDT,NPOP,J)
94 IEID = IEID + 1
GO TO 150
22 ISKIP1=ISKIP/2
28 IF(IDFLT.EQ.1) GO TO 505
IF(NPOP.EQ.1) GO TO 85
PUNCH 902,IEID,IPID,NG(I-2*ISKIP1,J-1),NG(I-ISKIP1,J-1),NG(I-ISKIP
1,J),TH
WRITE(6,903) IFID,IPID,NG(I-2*ISKIP1,J-1),NG(I-ISKIP1,J-1),NG(I-IS
1KIP,J),TH
IF(NPOP.EQ.0) GO TO 95
85 PUNCH 904,IEID,NG(I-2*ISKIP1,J-1),NG(I-ISKIP1,J-1),NG(I-ISKIP,J),
1TH,MID
WRITE(6,905) IFID,NG(I-2*ISKIP1,J-1),NG(I-ISKIP1,J-1),NG(I-ISKIP,J
1),TH,MID
GO TO 95
505 G3 = NG(I-ISKIP,J)
G2 = NG(I-ISKIP1,J-1)
G1 = NG(I-2*ISKIP1,J-1)
IF(G1.EQ.0) GO TO 150
IF(G2.EQ.0) GO TO 150
CALL WEDGE(G1,G2,G3,DELGP,KK,MID,IEID,ICLOSE,NDT,NPOP,J)
95 IEID = IEID + 1
IF(IDFLT.EQ.1) GO TO 506
IF(NPOP.EQ.1) GO TO 86
PUNCH 902,IFID,IPID,NG(I-ISKIP1,J-1),NG(I,J),NG(I-ISKIP,J),TH
WRITE(6,903) IFID,IPID,NG(I-ISKIP1,J-1),NG(I,J),NG(I-ISKIP,J),TH
IF(NPOP.EQ.0) GO TO 96
86 PUNCH 904,IFID,NG(I-ISKIP1,J-1),NG(I,J),NG(I-ISKIP,J),TH,MID
WRITE(6,905) IFID,NG(I-ISKIP1,J-1),NG(I,J),NG(I-ISKIP,J),TH,MID
GO TO 96
506 G3 = NG(I-ISKIP,J)
G2 = NG(I,J)
G1 = NG(I-ISKIP1,J-1)
CALL WEDGE(G1,G2,G3,DELGP,KK,MID,IEID,ICLOSE,NDT,NPOP,J)
96 IEID = IEID + 1
IF(IDFLT.EQ.1) GO TO 507
IF(NPOP.EQ.1) GO TO 87
PUNCH 902,IEID,IPID,NG(I-ISKIP1,J-1),NG(I,J-1),NG(I,J),TH
WRITE(6,903) IFID,IPID,NG(I-ISKIP1,J-1),NG(I,J-1),NG(I,J),TH

```

```

IF(NPOP.EQ.0) GO TO 97
87 PUNCH 904, IEID, NG(I-ISKIP1, J-1), NG(I, J-1), NG(I, J), TH, MID
WRITE(6, 905) IEID, NG(I-ISKIP1, J-1), NG(I, J-1), NG(I, J), TH, MID
GO TO 97
507 G3 = NG(I, J)
G2 = NG(I, J-1)
G1 = NG(I-ISKIP1, J-1)
CALL WEDGE(G1, G2, G3, DELGP, KK, MID, IEID, ICLOSE, NDT, NPOP, J)
97 IFID = IEID + 1
GO TO 150
21 IF(NTNT(K-1).GT.INTN) GO TO 24
IF(NTNT(K-1).LT.INTN) ISKIP1=ISKIP*2
IF(NG(I, J-1).EQ.0) GO TO 150
GO TO 26
24 ISKIP1 = ISKIP/2
GO TO 28
150 IFLAST=IEID
170 CONTINUE
IF(NPO.EQ.0) GO TO 200
JP=JMAX+1
NG(1, JP)=NGS
IF(NGP.EQ.1) GO TO 105
IF(IDFLT.EQ.1) GO TO 510
IF(NPS.GT.0) GO TO 71
PUNCH 910, NG(1, JP), NCP, X(1, JP), Y, Z(1, JP), NCD
WRITE(6, 911) NG(1, JP), NCP, X(1, JP), Y, Z(1, JP), NCD
GO TO 105
71 PUNCH 900, NG(1, JP), NCP, X(1, JP), Y, Z(1, JP), NCD, NPS
WRITE(6, 901) NG(1, JP), NCP, X(1, JP), Y, Z(1, JP), NCD, NPS
GO TO 105
510 II = 1
TH1 = THETA(II)
511 IF(NPS.GT.0) GO TO 74
PUNCH 910, NG(1, JP), NCP1, X(1, JP), TH1, Z(1, JP), NCP1
WRITE(6, 911) NG(1, JP), NCP1, X(1, JP), TH1, Z(1, JP), NCP1
GO TO 72
74 PUNCH 900, NG(1, JP), NCP1, X(1, JP), TH1, Z(1, JP), NCP1, NPS
WRITE(6, 901) NG(1, JP), NCP1, X(1, JP), TH1, Z(1, JP), NCP1, NPS
72 IF(TH1.EQ.THETA(II+1)) II=II+1
IF(TH1.EQ.THETA(NDT+1)) GO TO 100
DTHETA = (THETA(II+1)-THETA(II))/(KK(II+1)-KK(II))
NG(1, JP) = NG(1, JP) + 1
TH1 = TH1 + DTHETA
IF(TH1.EQ.360.0) GO TO 100
GO TO 511
100 IF(IDFLT.EQ.1) NG(1, JP) = NG(1, JP) - KK(NDT+1) + 1
105 NGLAST=NG(1, JP) + 1
MAX=MAXI-1
DO 60 I=MINI, MAX, ISKIP
IF(IDFLT.EQ.1) GO TO 508
IF(NPOP.EQ.1) GO TO 88
PUNCH 902, IFID, IPID, NG(I+ISKIP, JMAX), NG(1, JP), NG(I, JMAX), TH
WRITE(6, 903) IEID, IPID, NG(I+ISKIP, JMAX), NG(1, JP), NG(I, JMAX), TH
IF(NPOP.EQ.0) GO TO 60
88 PUNCH 904, IEID, NG(I+ISKIP, JMAX), NG(1, JP), NG(I, JMAX), TH, MID
WRITE(6, 905) IEID, NG(I+ISKIP, JMAX), NG(1, JP), NG(I, JMAX), TH, MID
GO TO 60
508 G3 = NG(I, JMAX)
G2 = NG(1, JP)
G1 = NG(I+ISKIP, JMAX)
J = JP
CALL WEDGE(G1, G2, G3, DELGP, KK, MID, IFID, ICLOSE, NDT, NPOP, J)
60 IEID=IEID+1
IELAST=IEID

```

PUNCHF  
PUNCHF  
PUNCHF

PUNCHF  
PUNCHF  
PUNCHF  
PUNCHF  
PUNCHF  
PUNCHF  
PUNCHF  
PUNCHF  
PUNCHF  
PUNCHF  
PUNCHF

PUNCHR  
PUNCHR  
PUNCHR  
PUNCHR  
PUNCHR  
PUNCHR  
PUNCHR  
PUNCHR  
PUNCHR

PUNCHR  
PUNCHR

```

      IF (IDELT.EQ.1) NGLAST = NGLAST + MAD
200 CONTINUE
      JMAXJ1 = JMAXJ
      JMINJ1 = JMINJ
400 FORMAT (I5)
402 FORMAT (2I5)
900 FORMAT (4HGRID,4Y,2I8,3F8.4,2I8)
901 FORMAT (5X,4HGRID,4X,2I8,3F8.4,2I8)
902 FORMAT (6HCTRIA2,2X,5I8,F8.4)
903 FORMAT (5X,6HCTRIA2,2X,5I8,F8.4)
904 FORMAT (7HCTRIARG,1X,4I8,F8.4,I8)
905 FORMAT (5X,7HCTRIARG,1X,4I8,F8.4,I8)
906 FORMAT (6HCQUAD2,2X,6I8,F8.4)
907 FORMAT (5X,6HCQUAD2,2X,6I8,F8.4)
908 FORMAT (7HCTRAPRG,1X,5I8,F8.4,I8)
909 FORMAT (5X,7HCTRAPRG,1X,5I8,F8.4,I8)
910 FORMAT (4HGRID,4X,2I8,3F8.4,I8)
911 FORMAT (5X,4HGRID,4X,2I8,3F8.4,I8)
      RETURN
      END
      SUBROUTINE WEDGE (G1,G2,G3,DELGP, KK,MID, IEID, ICLOSE, NDT, NPOP, J)
      DIMENSION KK(10), X(30,30), Z(30,30), NG(30,30), NGF(30,30), CODE(30,30
1), KSKIP(30,30), JB(10), JE(10), BETA(10), THETA(10), IMIN(30), IMAX(30)
      INTEGER G1,G2,G3,G4,G5,G6,DELGP
      COMMON X,Z,NG,NGF,KSKIP,NSECT,JB,JE,BETA,THETA,IMIN,IMAX,JMAX
11,JMIN1
      COMMON MPC,IU(2),JU(2),IM(2),JM(2),IL(2),JL(2),ICON,LS(2)
      COMMON ICONST(2),JCONST(2)
C *** THIS SUBROUTINE PUNCHES THE SOLID ELEMENT CONNECTION CARDS
C *** (CWEDGE) AND CROD + CTRIA2 CARDS FOR DISPLAY ON GRID .
      T = 0.0
      IBEG = IEID
      G4 = G1 + 1
      G5 = G2 + 1
      G6 = G3 + 1
      IF (ICLOSE.EQ.0) GO TO 100
      GO TO 101
100 IG1 = G1
      IG2 = G2
      IG3 = G3
101 JJ = KK(NDT+1) - 1
      I = 1
      IJ = 1
      TH1 = THETA(I)
      DO 99 L=1, JJ
      IF (TH1.GE.BETA(IJ).AND.TH1.LT.BETA(IJ+1)) GO TO 300
      IJ = IJ + 1
300 IF (J.LE.JB(IJ).OR.J.GT.JE(IJ)) GO TO 105
      IF (NPOP.EQ.4) GO TO 200
      PUNCH 600, IEID, MID, G1, G2, G3, G4, G5, G6
      WRITE (6, 601) IEID, MID, G1, G2, G3, G4, G5, G6
      IF (NPOP.EQ.3) GO TO 105
200 ID = IEID
      IE = ID + DELGP
      IF (NSECT.GT.1) GO TO 120
      IF (L.GT.1) GO TO 110
      IF (L.EQ.JJ.AND.ICLOSE.EQ.0) GO TO 111
120 PUNCH 800, ID, ID, G1, G2, G3, T
110 PUNCH 800, IE, IE, G4, G5, G6, T
111 ID = IE + DELGP
      IE = ID + DELGP
      PUNCH 700, ID, ID, G1, G4, IE, IE, G2, G5
      ID = IE + DELGP
      PUNCH 700, ID, ID, G3, G6

```

```

105 G1 = G4
    G2 = G5
    G3 = G6
    G4 = G4 + 1
    G5 = G5 + 1
    G6 = G6 + 1
    IFID = IEID + DELGP
    IF (TH1.EQ.THETA(I+1)) I=I+1
    DTHETA = (THETA(I+1)-THETA(I))/(KK(I+1)-KK(I))
    TH1 = TH1 + DTHETA
    IF (L.EQ.JJ-1.AND.ICLOSE.EQ.0) GO TO 103
    GO TO 99
103 G4 = IG1
    G5 = IG2
    G6 = IG3
    99 CONTINUE
    IFID = IBFG
600 FORMAT(6HCWEDGE,2X,8I8)
601 FORMAT(5X,6HCWEDGE,2X,8I8)
700 FORMAT(4HCROD,4X,8I8)
701 FORMAT(5X,4HCROD,4X,8I8)
800 FORMAT(6HCTRIA2,2X,5I8,F8.4)
    RETURN
    END
    SUBROUTINE MPOC(ML,NCALL,I,J,NDT,KK,IFIX,MAXI,JMAX)
    INTEGER CZ(5),CN(5),CO(5),CT(5),CB(5),CZM(5),CNM(5),COM(5),CTM(5),
    1CBM(5),C(5),CM(5),A,B,F,F,G,H,P,Q
    INTEGER CZ1(5),CN1(5),CO1(5),CT1(5),CB1(5),CZM1(5),CNM1(5),COM1(5)
    1,CTM1(5),CBM1(5)
    INTEGER CZ2(5),CN2(5),CO2(5),CT2(5),CB2(5),CZM2(5),CNM2(5),COM2(5)
    1,CTM2(5),CBM2(5)
    DIMENSION X(30,30),S(30,30),NT(10),NG(30,30),DELTZ(10),CODE(30,30)
    DIMENSION NGF(30,30),KSKIP(30,30),KK(10),THETA(10),JB(10),JE(10)
    1,BETA(10),IMIN(30),IMAX(30),TITLE(13)
    COMMON X,S,NG,COCF,NGF,KSKIP,NSECT,JB,JE,BETA,THETA,IMIN,IMAX,JMAX
    11,JMIN1
    COMMON MPC,IU(2),JU(2),IM(2),JM(2),IL(2),JL(2),ICON,LS(2)
    COMMON ICONST(2),JCONST(2)
    DATA F/1H1/, G/1H2/, H/1H3/, P/1H5/, O/1H6/
    NCP = 1
    IPUN = 0
    IF (TFIX.EQ.4) GO TO 300
    IF (ML.EQ.1.AND.NCALL.EQ.0) GO TO 6
    IF (ML.EQ.2.AND.NCALL.EQ.0) GO TO 7
    IF (ML.EQ.2.AND.NCALL.EQ.1) GO TO 7
    GO TO 9
    6 NCALL = 1
    GO TO 10
    7 NCALL = 2
    GO TO 220
    10 READ(5,120) (CZ1(KA),KA=1,5),(CN1(KB),KB=1,5),(CO1(KC),KC=1,5),(CT
    11(KD),KD=1,5),(CB1(KE),KE=1,5),(CZM1(KF),KF=1,5),(CNM1(KG),KG=1,5
    2),(COM1(KH),KH=1,5),(CTM1(KI),KI=1,5),(CBM1(KJ),KJ=1,5)
    IF (LS(1).EQ.LS(2)) GO TO 221
    GO TO 9
    221 NCALL = 2
    220 READ(5,120) (CZ2(KA),KA=1,5),(CN2(KB),KB=1,5),(CO2(KC),KC=1,5),(CT
    12(KD),KD=1,5),(CB2(KE),KE=1,5),(CZM2(KF),KF=1,5),(CNM2(KG),KG=1,5
    2),(COM2(KH),KH=1,5),(CTM2(KI),KI=1,5),(CBM2(KJ),KJ=1,5)
    9 IF (ML.EQ.?) GO TO 222
    DO 225 L=1,5
    CZ(L) = CZ1(L)
    CN(L) = CN1(L)
    CO(L) = CO1(L)

```

```

CT(L) = CT1(L)
CB(L) = CB1(L)
CZM(L) = CZM1(L)
CNM(L) = CNM1(L)
COM(L) = COM1(L)
CTM(L) = CTM1(L)
225 CBM(L) = CBM1(L)
GO TO 230
222 DO 235 L=1,5
CZ(L) = CZ2(L)
CN(L) = CN2(L)
CO(L) = CO2(L)
CT(L) = CT2(L)
CB(L) = CB2(L)
CZM(L) = CZM2(L)
CNM(L) = CNM2(L)
COM(L) = COM2(L)
CTM(L) = CTM2(L)
235 CBM(L) = CBM2(L)
230 IF(IU(ML).EQ.I.AND.JU(ML).EQ.J) GO TO 5
IF(IL(ML).EQ.I.AND.JL(ML).EQ.J) GO TO 8
II = 1
TH1 = THETA(II)
20 IF(TH1.EQ.0.0) GO TO 11
IF(TH1.EQ.90.0) GO TO 12
IF(TH1.EQ.180.0) GO TO 13
IF(TH1.EQ.270.0) GO TO 14
PUNCH 100,NG(I,J),NCP,X(I,J),TH1,S(I,J),NCP,(CBM(L),L=1,5)
WRITE(6,101) NG(I,J),NCP,X(I,J),TH1,S(I,J),NCP,(CBM(L),L=1,5)
GO TO 15
11 PUNCH 100,NG(I,J),NCP,X(I,J),TH1,S(I,J),NCP,(CZM(L),L=1,5)
WRITE(6,101) NG(I,J),NCP,X(I,J),TH1,S(I,J),NCP,(CZM(L),L=1,5)
GO TO 15
12 PUNCH 100,NG(I,J),NCP,X(I,J),TH1,S(I,J),NCP,(CNM(L),L=1,5)
WRITE(6,101) NG(I,J),NCP,X(I,J),TH1,S(I,J),NCP,(CNM(L),L=1,5)
GO TO 15
13 PUNCH 100,NG(I,J),NCP,X(I,J),TH1,S(I,J),NCP,(COM(L),L=1,5)
WRITE(6,101) NG(I,J),NCP,X(I,J),TH1,S(I,J),NCP,(COM(L),L=1,5)
GO TO 15
14 PUNCH 100,NG(I,J),NCP,X(I,J),TH1,S(I,J),NCP,(CTM(L),L=1,5)
WRITE(6,101) NG(I,J),NCP,X(I,J),TH1,S(I,J),NCP,(CTM(L),L=1,5)
15 GO TO 94
300 IO = 1
IA=1
IB=2
IC=3
IF=5
IE=6
Z=1.0
D=-1.0
ISAVE = I
JSAVE = J
II = 1
TH1 = THETA(II)
NG(IM(ML),JM(ML)) = NG(IM(ML),JM(ML))
NG(IL(ML),JL(ML)) = NG(IL(ML),JL(ML))
NG(IU(ML),JU(ML)) = NG(IU(ML),JU(ML))
330 A=B=E=0
IF(TH1.EQ.0.0) GO TO 301
IF(TH1.EQ.90.0) GO TO 302
IF(TH1.EQ.180.0) GO TO 303
IF(TH1.EQ.270.0) GO TO 304
DO 25 K=1,5
C(K) =CB(K)

```

```

25 CM(K) = C9M(K)
   GO TO 325
301 DO 26 K=1,5
    C(K) = CZ(K)
26 CM(K) = CZM(K)
   GO TO 325
302 DO 30 K=1,5
    C(K) = CN(K)
30 CM(K) = CNM(K)
   GO TO 325
303 DO 31 K=1,5
    C(K) = CO(K)
31 CM(K) = COM(K)
   GO TO 325
304 DO 32 K=1,5
    C(K) = CT(K)
32 CM(K) = CTM(K)
325 I = IM(ML)
    J = JM(ML)
    RU = X(IU(ML),JU(ML)) - X(I,J)
    RL = X(IL(ML),JL(ML)) - X(I,J)
    RR = X(I,J) - X(IU(ML),JU(ML))
    RS = X(I,J) - X(IL(ML),JL(ML))
    DO 40 M=1,5
      IF (CM(M).EQ.F) A=1
      IF (CM(M).EQ.G) B=1
40 IF (CM(M).EQ.H) E=1
      IF (B.EQ.1) GO TO 45
      GO TO 46
61 IF (E.EQ.1) GO TO 50
      GO TO 51
45 DO 60 N=1,5
60 IF (CM(N).EQ.Q) B=2
      GO TO 61
46 DO 65 LN=1,5
65 IF (CM(LN).EQ.Q) B=3
      GO TO 61
50 DO 75 KL=1,5
75 IF (CM(KL).EQ.P) E=2
      GO TO 64
51 DO 76 LK=1,5
76 IF (CM(LK).EQ.P) E=3
64 DO 62 LM=1,5
      IF (C(LM).EQ.F) A=1
      IF (C(LM).EQ.G.AND.B.EQ.1) B=2
      IF (C(LM).EQ.G.AND.B.EQ.3) B=2
      IF (C(LM).EQ.H.AND.E.EQ.1) E=2
62 IF (C(LM).EQ.H.AND.E.EQ.3) E=2
      IF (A.EQ.1) GO TO 80
      PUNCH 105, ID, NG(IU(ML),JU(ML)), IA, Z, NG(I,J), IA, D
      WRITE(6,106) ID, NG(IU(ML),JU(ML)), IA, Z, NG(I,J), IA, D
      PUNCH 105, ID, NG(IL(ML),JL(ML)), IA, Z, NG(I,J), IA, D
      WRITE(6,106) ID, NG(IL(ML),JL(ML)), IA, Z, NG(I,J), IA, D
80 IF (B.EQ.0) GO TO 81
      IF (B.EQ.1) GO TO 82
      IF (B.EQ.3) GO TO 83
      GO TO 84
81 PUNCH 109, ID, NG(IU(ML),JU(ML)), IB, Z, NG(I,J), IE, RR, ICON
      WRITE(6,110) ID, NG(IU(ML),JU(ML)), IB, Z, NG(I,J), IE, RR, ICON
      PUNCH 107, ICON, NG(I,J), IB, D
      WRITE(6,108) ICON, NG(I,J), IB, D
      ICON = ICON + 1
      PUNCH 109, ID, NG(IL(ML),JL(ML)), IB, Z, NG(I,J), IE, RS, ICON
      WRITE(6,110) ID, NG(IL(ML),JL(ML)), IB, Z, NG(I,J), IE, RS, ICON

```

```

PUNCH 107,ICON,NG(I,J),IB,D
WRITE(6,108) ICON,NG(I,J),IB,D
ICON = ICON + 1
GO TO 84
82 PUNCH 105, ID,NG(IU(ML),JU(ML)),IB,Z,NG(I,J),IE,RR
WRITE(6,106) ID,NG(IU(ML),JU(ML)),IB,Z,NG(I,J),IE,RR
PUNCH 105, ID,NG(IL(ML),JL(ML)),IB,Z,NG(I,J),IE,RS
WRITE(6,106) ID,NG(IL(ML),JL(ML)),IB,Z,NG(I,J),IE,RS
GO TO 84
83 PUNCH 105, ID,NG(IU(ML),JU(ML)),IB,Z,NG(I,J),IB,D
WRITE(6,106) ID,NG(IU(ML),JU(ML)),IB,Z,NG(I,J),IB,D
PUNCH 105, ID,NG(IL(ML),JL(ML)),IB,Z,NG(I,J),IB,D
WRITE(6,106) ID,NG(IL(ML),JL(ML)),IB,Z,NG(I,J),IB,D
84 CONTINUE
IF (E.EQ.0) GO TO 91
IF (E.EQ.1) GO TO 92
IF (E.EQ.3) GO TO 93
GO TO 94
91 PUNCH 109, ID,NG(IU(ML),JU(ML)),IC,Z,NG(I,J),IF,RU,ICON
WRITE(6,110) ID,NG(IU(ML),JU(ML)),IC,Z,NG(I,J),IF,RU,ICON
PUNCH 107, ICON,NG(I,J),IC,D
WRITE(6,108) ICON,NG(I,J),IC,D
ICON = ICON + 1
PUNCH 109, ID,NG(IL(ML),JL(ML)),IC,Z,NG(I,J),IF,RL,ICON
WRITE(6,110) ID,NG(IL(ML),JL(ML)),IC,Z,NG(I,J),IF,RL,ICON
PUNCH 107, ICON,NG(I,J),IC,D
WRITE(6,108) ICON,NG(I,J),IC,D
ICON = ICON + 1
GO TO 94
92 PUNCH 105, ID,NG(IU(ML),JU(ML)),IC,Z,NG(I,J),IF,RU
WRITE(6,106) ID,NG(IU(ML),JU(ML)),IC,Z,NG(I,J),IF,RU
PUNCH 105, ID,NG(IL(ML),JL(ML)),IC,Z,NG(I,J),IF,RL
WRITE(6,106) ID,NG(IL(ML),JL(ML)),IC,Z,NG(I,J),IF,RL
GO TO 94
93 PUNCH 105, ID,NG(IU(ML),JU(ML)),IC,Z,NG(I,J),IC,D
WRITE(6,106) ID,NG(IU(ML),JU(ML)),IC,Z,NG(I,J),IC,D
PUNCH 105, ID,NG(IL(ML),JL(ML)),IC,Z,NG(I,J),IC,D
WRITE(6,106) ID,NG(IL(ML),JL(ML)),IC,Z,NG(I,J),IC,D
94 CONTINUE
IF (TH1.EQ.THETA(II+1)) II=II+1
IF (TH1.EQ.THETA(NDT+1)) GO TO 70
DTHETA = (THETA(II+1)-THETA(II))/(KK(II+1)-KK(II))
NG(I,J)=NG(I,J)+1
NG(IU(ML),JU(ML))=NG(IU(ML),JU(ML)) + 1
NG(IL(ML),JL(ML))=NG(IL(ML),JL(ML)) + 1
TH1=TH1 + DTHETA
IF (TH1.EQ.360.0) GO TO 70
IF (IFIX.EQ.4) GO TO 330
IF (IPUN.EQ.1) GO TO 330
GO TO 20
70 NG(I,J) = NG(I,J) - (KK(NDT+1)-1)
NG(IU(ML),JU(ML)) = NG(IU(ML),JU(ML))-(KK(NDT+1)-1)
NG(IL(ML),JL(ML)) = NG(IL(ML),JL(ML))-(KK(NDT+1)-1)
GO TO 210
5 CONTINUE
8 CONTINUE
II = 1
TH1 = THETA(II)
125 IF (TH1.EQ.0.0) GO TO 130
IF (TH1.EQ.90.0) GO TO 131
IF (TH1.EQ.180.0) GO TO 132
IF (TH1.EQ.270.0) GO TO 133
PUNCH 100,NG(I,J),NCP,X(I,J),TH1,S(I,J),NCP,(CB(L),L=1,5)
WRITE(6,101) NG(I,J),NCP,X(I,J),TH1,S(I,J),NCP,(CB(L),L=1,5)

```

```

GO TO 201
130 PUNCH 100,NG(I,J),NCP,X(I,J),TH1,S(I,J),NCP,(CZ(L),L=1,5)
WRITE(6,101) NG(I,J),NCP,X(I,J),TH1,S(I,J),NCP,(CZ(L),L=1,5)
GO TO 201
131 PUNCH 100,NG(I,J),NCP,X(I,J),TH1,S(I,J),NCP,(CN(L),L=1,5)
WRITE(6,101) NG(I,J),NCP,X(I,J),TH1,S(I,J),NCP,(CN(L),L=1,5)
GO TO 201
132 PUNCH 100,NG(I,J),NCP,X(I,J),TH1,S(I,J),NCP,(CO(L),L=1,5)
WRITE(6,101) NG(I,J),NCP,X(I,J),TH1,S(I,J),NCP,(CO(L),L=1,5)
GO TO 201
133 PUNCH 100,NG(I,J),NCP,X(I,J),TH1,S(I,J),NCP,(CT(L),L=1,5)
WRITE(6,101) NG(I,J),NCP,X(I,J),TH1,S(I,J),NCP,(CT(L),L=1,5)
201 CONTINUE
IF(TH1.EQ.THETA(II+1)) II=II+1
IF(TH1.EQ.THETA(NDT+1)) GO TO 205
DTHETA = (THETA(II+1)-THETA(II))/(KK(II+1)-KK(II))
NG(I,J)=NG(I,J)+1
TH1=TH1 + DTHETA
IF(TH1.EQ.360.0) GO TO 205
GO TO 125
210 CONTINUE
IF(I.EQ.IM(ML).AND.J.EQ.JM(ML)) GO TO 360
205 NG(I,J) = NG(I,J) - (KK(NDT+1) - 1)
GO TO 400
360 CONTINUE
IF(IFIX.NE.4) GO TO 400
I = ISAVE
J = JSAVE
400 CONTINUE
IF(IPUN.EQ.1) GO TO 425
IF(I.EQ.MAXI.AND.J.EQ.JMAX) GO TO 410
GO TO 411
410 IF(IPUN.EQ.0) GO TO 420
GO TO 411
420 IPUN = 1
GO TO 300
425 I = ISAVE
J = JSAVE
411 CONTINUE
100 FORMAT(4HGRID,4X,2I8,3F8.3,I8,3X,5A1)
101 FORMAT(5X,4HGRID,4X,2I8,3F8.3,I8,3X,5A1)
105 FORMAT(3HMPC,5X,3I8,F8.3,2I8,F8.3)
106 FORMAT(5X,3HMPC,5X,3I8,F8.3,2I8,F8.3)
107 FORMAT(1H+,I3,12X,2I8,F8.3)
108 FORMAT(5X,1H+,I3,12X,2I8,F8.3)
109 FORMAT(3HMPC,5X,3I8,F8.3,2I8,F8.3,8X,1H+,I3)
110 FORMAT(5X,3HMPC,5X,3I8,F8.3,2I8,F8.3,8X,1H+,I3)
120 FORMAT(50A1)
RETURN
END

```

NSWC/WOL TR 77-85

APPENDIX B  
DEMONSTRATION PROBLEMS

This appendix presents eight sample problems. Each one demonstrates some of the important features of JIG. Each of the following problems gives a statement emphasizing these important features, the mesh planning and preparation of data, the input and output listings, and a hardcopy of the structural plot.

- B-I. Triangular Membrane and Bending, Axisymmetric Triangular Ring, and 3-D Solid Elements - featuring CTRIA2, CTTRIARG and CWEDGE finite element structural models.
- B-II. Variable Cross-Section's - featuring solid wedge finite element model having variable cross section.
- B-III. Repeated sections - featuring repeated sections used in a threaded joint.
- B-IV. Variable Theta - featuring variable theta options for CWEDGE structural finite element models.
- B-V. Prescribed Points and Lines - featuring prescribed point and line options. (Applies to a cross section).
- B-VI. Transition -featuring combinations of increasing and decreasing the mesh size of a structural model (R-direction only).
- B-VII. MPC Generator - featuring the generation of MPC cards for connection of solid wedge to plate elements.
- B-VIII. Curved Boundary - featuring a nozzle using the curved boundary option.

## PROBLEM B-I

## TRIANGULAR MEMBRANE AND BENDING, AXISYMMETRIC

## TRIANGULAR RING AND 3-D SOLID ELEMENTS

The three following examples demonstrate the use of CTRIA2, CTRIARG and the CWEDGE options. Figure B-1, shows the planned finite element model and configuration of the cross-section of a solid ring. This model shall be used to demonstrate all three of the above options. In example B-I-A the CTRIA2 punch option is shown. The model, consisting of a constant thickness flat plate, was divided into five equal spaces in the I - Z direction and four equal spaces in the J - X or R direction. A complete listing of the data input is shown in Figure B-2. Figure B-3 shows the grid point and element identification numbers as generated by JIG. Figure B-4 gives a structural plot of the finite element model and is followed by a listing of the JIG punched output.

Example B-I-B demonstrates the CTRIARG option. Figure B-1 shows the planned finite element model and configuration of an axisymmetric ring. A complete listing of the data input is shown in Figure B-5. Figure B-6 shows the the grid point and element identification numbers as generated by JIG. Figure B-7 gives a structural plot of the finite element model and is followed by a listing of the JIG punched output.

In example B-I-C the CWEDGE punch option is shown. The planned finite element model and configuration of the solid 3-D element option is shown in Figure B-1. The model was divided into five equal spaces in the I - Z direction, four equal spaces in the J - X or R direction, and six equal spaces in the theta direction. A complete listing of the data input is shown in Figure B-8. Figures B-9 and B-10 show

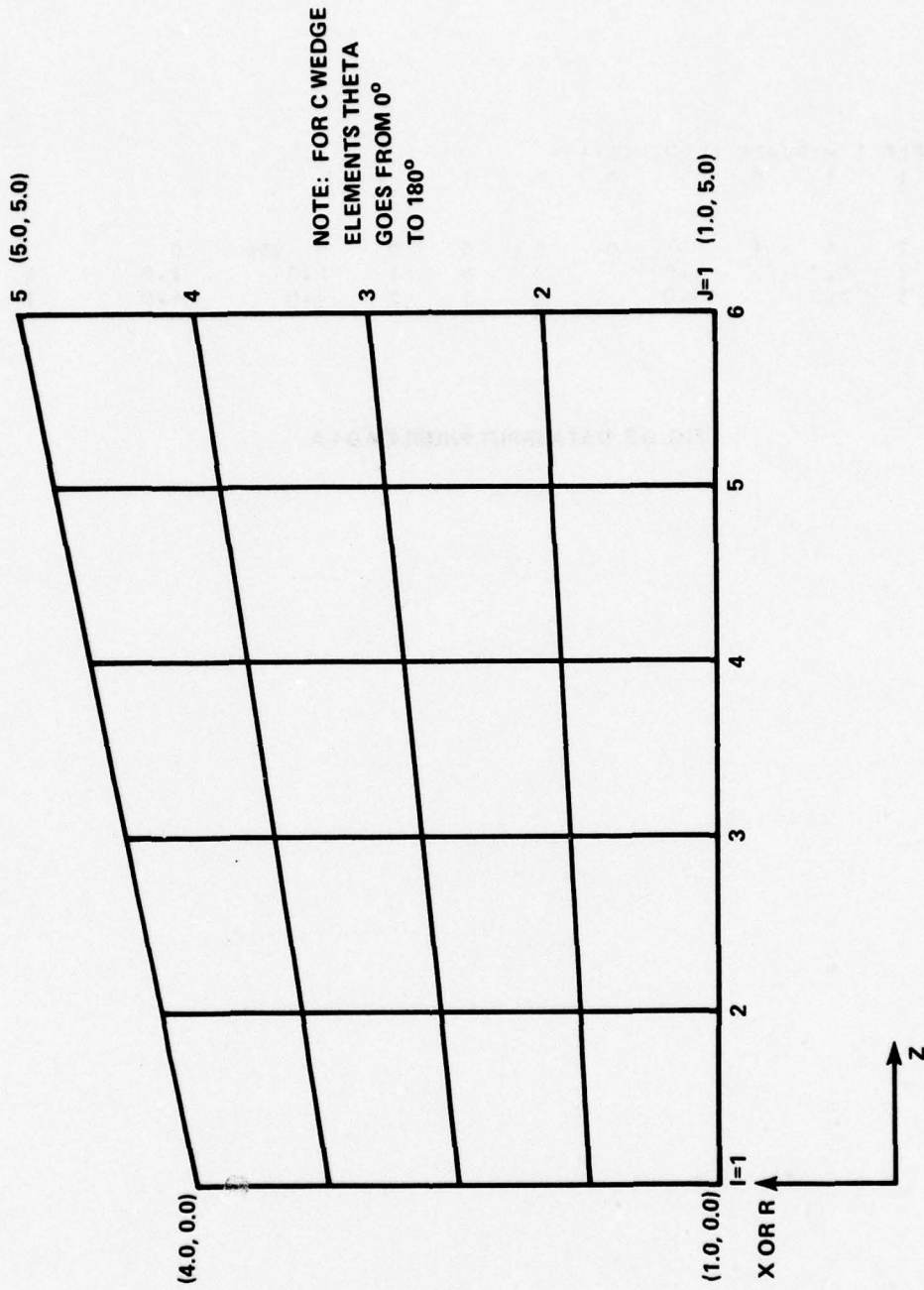

FIG. B-1 FINITE ELEMENT MODEL AND CONFIGURATION OF THE CROSS-SECTION OF A SOLID RING

\*\*\* SAMPLE 1 - PLATE ELEMENTS \*\*\*

1	1	1	0	5	0	0	1						
1													
0.0													
4	1	5	1	6	0	0	0	0	0	456	0		
1	1	0.0		1.0		1	6	1	5.0		1.0	1	
6	5	5.0		5.0		1	1	5	0.0		4.0	1	

FIG. B-2 DATA INPUT PROBLEM B-1-A

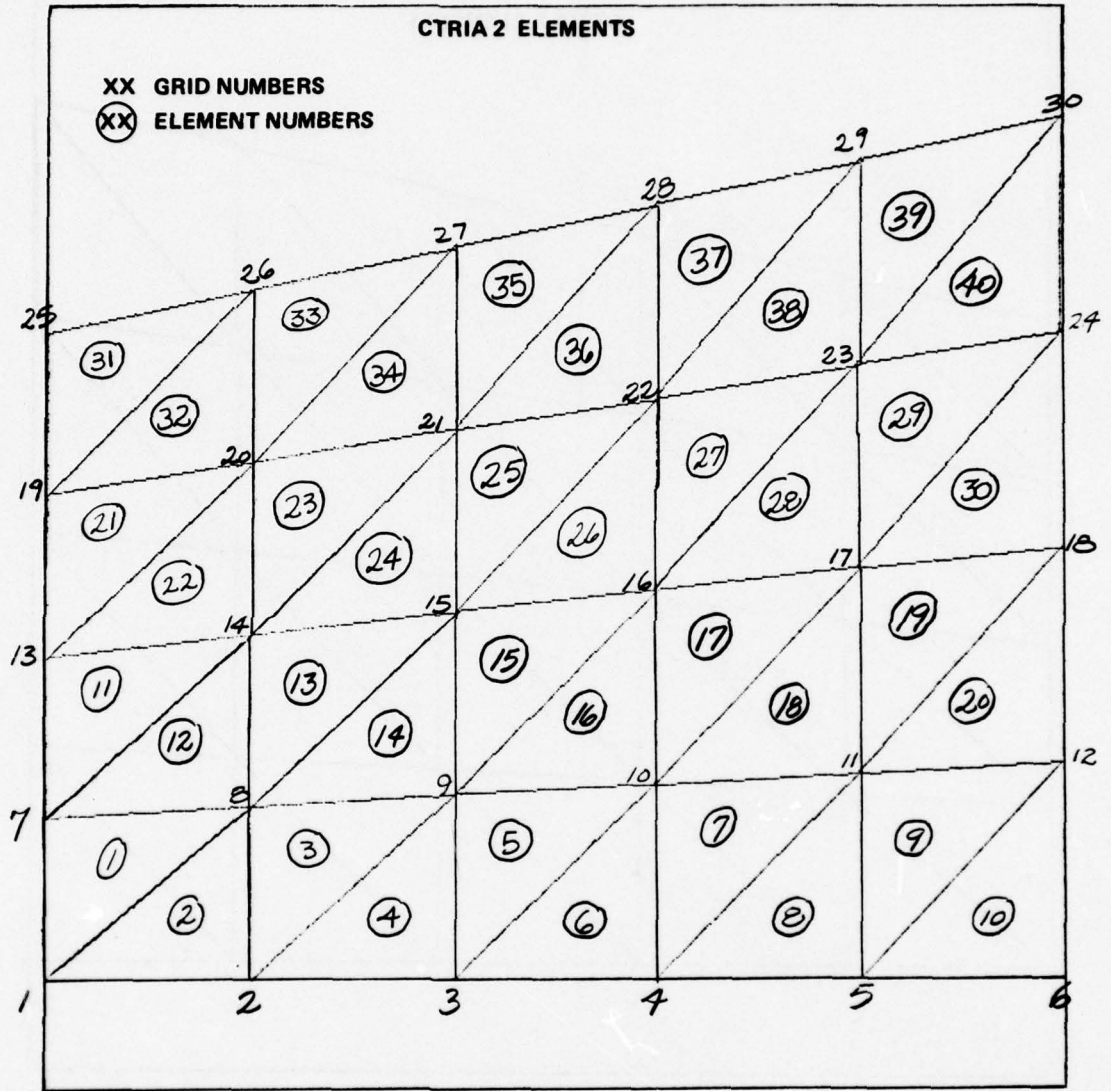
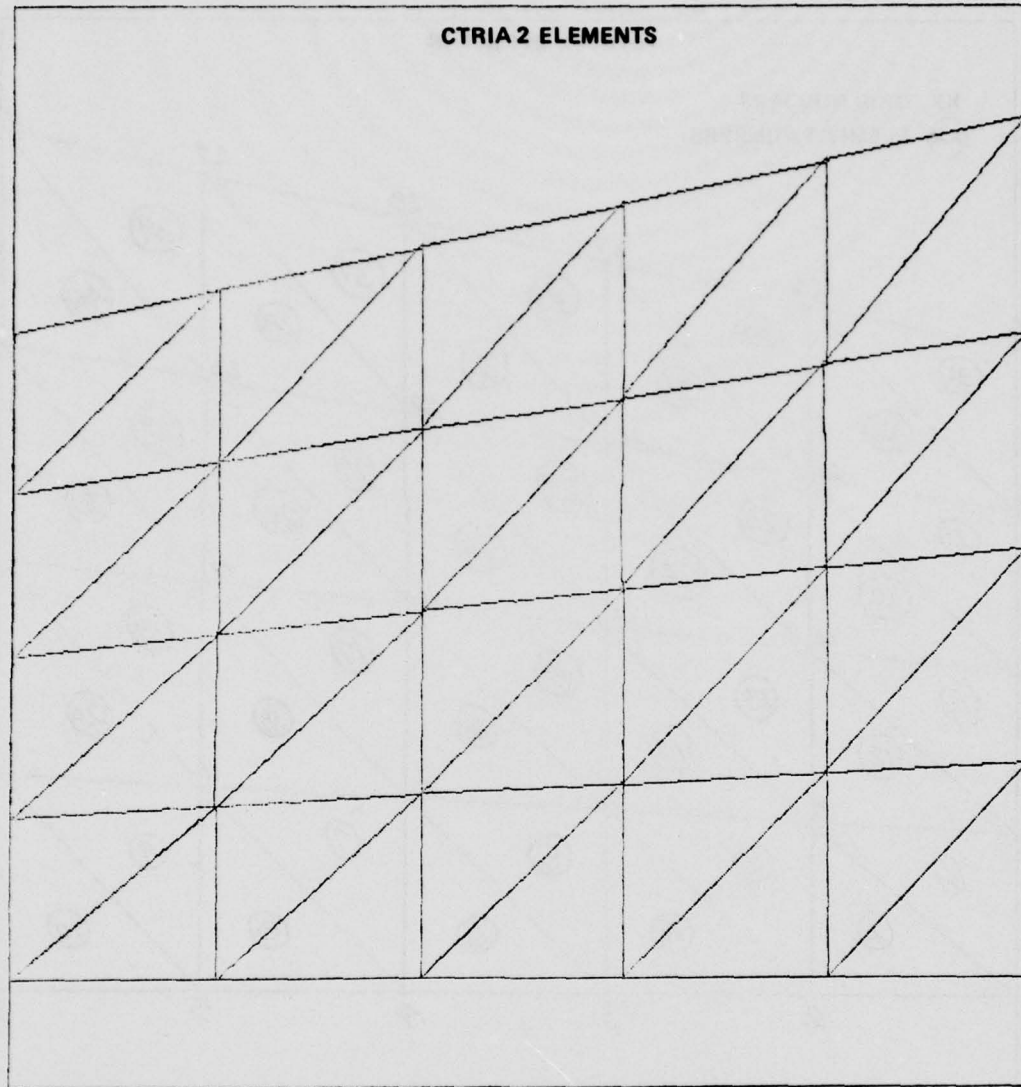

FIG. B-3 GRID POINT AND ELEMENT IDENTIFICATION NUMBERS



**FIG. B-4 NASTRAN STRUCTURAL PLOT**

LISTING OF PUNCHED NASTRAN BULK DATA CARDS  
PROBLEM B-I-A TRIANGULAR MEMBRANE ELEMENTS

```
*****  
*****  
** JUNCTION INPUT GENERATOR PROGRAM (JIG) **  
**  
*****  
*****
```

\*\*\* SAMPLE 1 - PLATE ELEMENTS \*\*\*

```
NST = 1  
NGS = 1  
NES = 1  
NPOP = 0  
MID = 5  
NGP = 0  
IDELT = 0  
NSECT = 1  
NT( 1) = 1      DELTZ( 1) = 0.0000
```

NSWC/WOL TR 77-85

I	J	Z(I,J)	X(I,J)	CODE(I,J)				
1	1	0.00000	1.00000	1				
2	1	1.00000	1.00000	1				
3	1	2.00000	1.00000	1				
4	1	3.00000	1.00000	1				
5	1	4.00000	1.00000	1				
6	1	5.00000	1.00000	1				
1	2	0.00000	1.75000	1				
2	2	1.00000	1.79999	0				
3	2	2.00001	1.85002	0				
4	2	3.00002	1.90000	0				
5	2	3.99999	1.94998	0				
6	2	5.00000	2.00000	1				
1	3	0.00000	2.50000	1				
2	3	1.00003	2.60002	0				
3	3	2.00002	2.70002	0				
4	3	3.00000	2.79999	0				
5	3	4.00000	2.90000	0				
6	3	5.00000	3.00000	1				
1	4	0.00000	3.25000	1				
2	4	1.00002	3.40002	0				
3	4	1.99998	3.54999	0				
4	4	3.00000	3.70000	0				
5	4	4.00000	3.84999	0				
6	4	5.00000	4.00000	1				
1	5	0.00000	4.00000	1				
2	5	1.00000	4.20000	1				
3	5	2.00000	4.40000	1				
4	5	3.00000	4.60000	1				
5	5	4.00000	4.80000	1				
6	5	5.00000	5.00000	1				
GRID		1	0	1.0000	0.0000	0.0000	0	456
GRID		2	0	1.0000	0.0000	1.0000	0	456
GRID		3	0	1.0000	0.0000	2.0000	0	456
GRID		4	0	1.0000	0.0000	3.0000	0	456
GRID		5	0	1.0000	0.0000	4.0000	0	456
GRID		6	0	1.0000	0.0000	5.0000	0	456
GRID		7	0	1.7500	0.0000	0.0000	0	456
GRID		8	0	1.8000	0.0000	1.0000	0	456
CTRIA?		1	1	8	7	1	0.0000	
CTRIA?		2	1	1	2	8	0.0000	
GRID		9	0	1.8500	0.0000	2.0000	0	456
CTRIA?		3	1	9	8	2	0.0000	
CTRIA?		4	1	2	3	9	0.0000	
GRID		10	0	1.9000	0.0000	3.0000	0	456
CTRIA?		5	1	10	9	3	0.0000	
CTRIA?		6	1	3	4	10	0.0000	
GRID		11	0	1.9500	0.0000	4.0000	0	456
CTRIA?		7	1	11	10	4	0.0000	
CTRIA?		8	1	4	5	11	0.0000	
GRID		12	0	2.0000	0.0000	5.0000	0	456
CTRIA?		9	1	12	11	5	0.0000	
CTRIA?		10	1	5	6	12	0.0000	
GRID		13	0	2.5000	0.0000	0.0000	0	456
GRID		14	0	2.6000	0.0000	1.0000	0	456
CTRIA?		11	1	14	13	7	0.0000	
CTRIA?		12	1	7	8	14	0.0000	
GRID		15	0	2.7000	0.0000	2.0000	0	456
CTRIA?		13	1	15	14	8	0.0000	

## NSWC/WOL TR 77-85

CTRIA2	14	1	8	9	15	0.0000	
GRID	16	0	2.8000	0.0000	3.0000	0	456
CTRIA2	15	1	16	15	9	0.0000	
CTRIA2	16	1	9	10	16	0.0000	
GRID	17	0	2.9000	0.0000	4.0000	0	456
CTRIA2	17	1	17	16	10	0.0000	
CTRIA2	18	1	10	11	17	0.0000	
GRID	18	0	3.0000	0.0000	5.0000	0	456
CTRIA2	19	1	18	17	11	0.0000	
CTRIA2	20	1	11	12	18	0.0000	
GRID	19	0	3.2500	0.0000	0.0000	0	456
GRID	20	0	3.4000	0.0000	1.0000	0	456
CTRIA2	21	1	20	19	13	0.0000	
CTRIA2	22	1	13	14	20	0.0000	
GRID	21	0	3.5500	0.0000	2.0000	0	456
CTRIA2	23	1	21	20	14	0.0000	
CTRIA2	24	1	14	15	21	0.0000	
GRID	22	0	3.7000	0.0000	3.0000	0	456
CTRIA2	25	1	22	21	15	0.0000	
CTRIA2	26	1	15	16	22	0.0000	
GRID	23	0	3.8500	0.0000	4.0000	0	456
CTRIA2	27	1	23	22	16	0.0000	
CTRIA2	28	1	16	17	23	0.0000	
GRID	24	0	4.0000	0.0000	5.0000	0	456
CTRIA2	29	1	24	23	17	0.0000	
CTRIA2	30	1	17	18	24	0.0000	
GRID	25	0	4.0000	0.0000	0.0000	0	456
GRID	26	0	4.2000	0.0000	1.0000	0	456
CTRIA2	31	1	26	25	19	0.0000	
CTRIA2	32	1	19	20	26	0.0000	
GRID	27	0	4.4000	0.0000	2.0000	0	456
CTRIA2	33	1	27	26	20	0.0000	
CTRIA2	34	1	20	21	27	0.0000	
GRID	28	0	4.6000	0.0000	3.0000	0	456
CTRIA2	35	1	28	27	21	0.0000	
CTRIA2	36	1	21	22	28	0.0000	
GRID	29	0	4.8000	0.0000	4.0000	0	456
CTRIA2	37	1	29	28	22	0.0000	
CTRIA2	38	1	22	23	29	0.0000	
GRID	30	0	5.0000	0.0000	5.0000	0	456
CTRIA2	39	1	30	29	23	0.0000	
CTRIA2	40	1	23	24	30	0.0000	

\*\*\* SAMPLE 1 - AXISYMMETRIC RING ELEMENTS \*\*\*

1	1	1	1	5	0	0	1						
1													
0.0													
4	1	5	1	6	0	0	0	0	0	456	0		
1	1	0.0		1.0		1	6	1	5.0		1.0		1
6	5	5.0		5.0		1	1	5	0.0		4.0		1

FIG B-5 DATA INPUT PROBLEM B-I-B

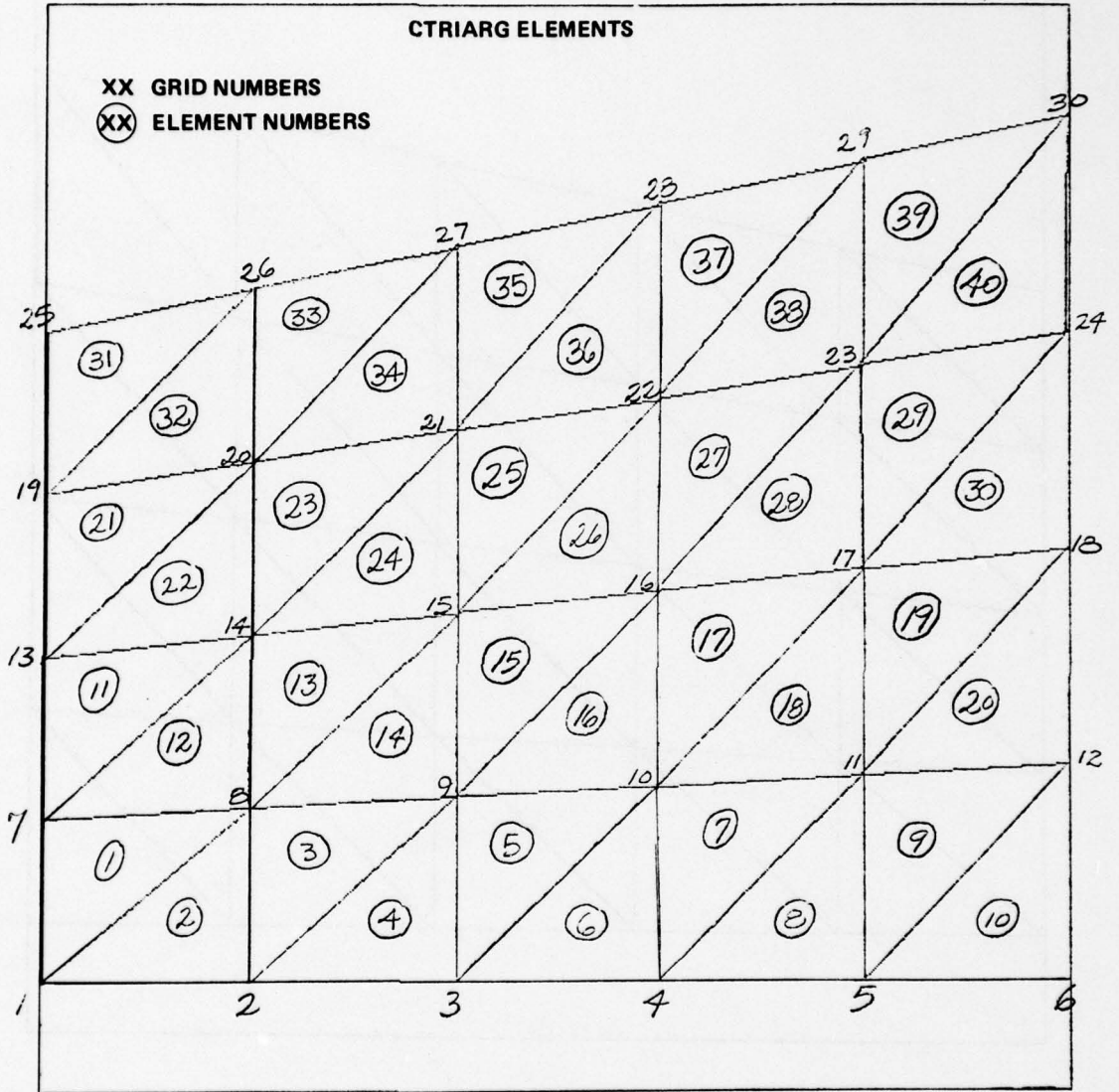

FIG. B-6 GRID POINT AND ELEMENT IDENTIFICATION NUMBERS

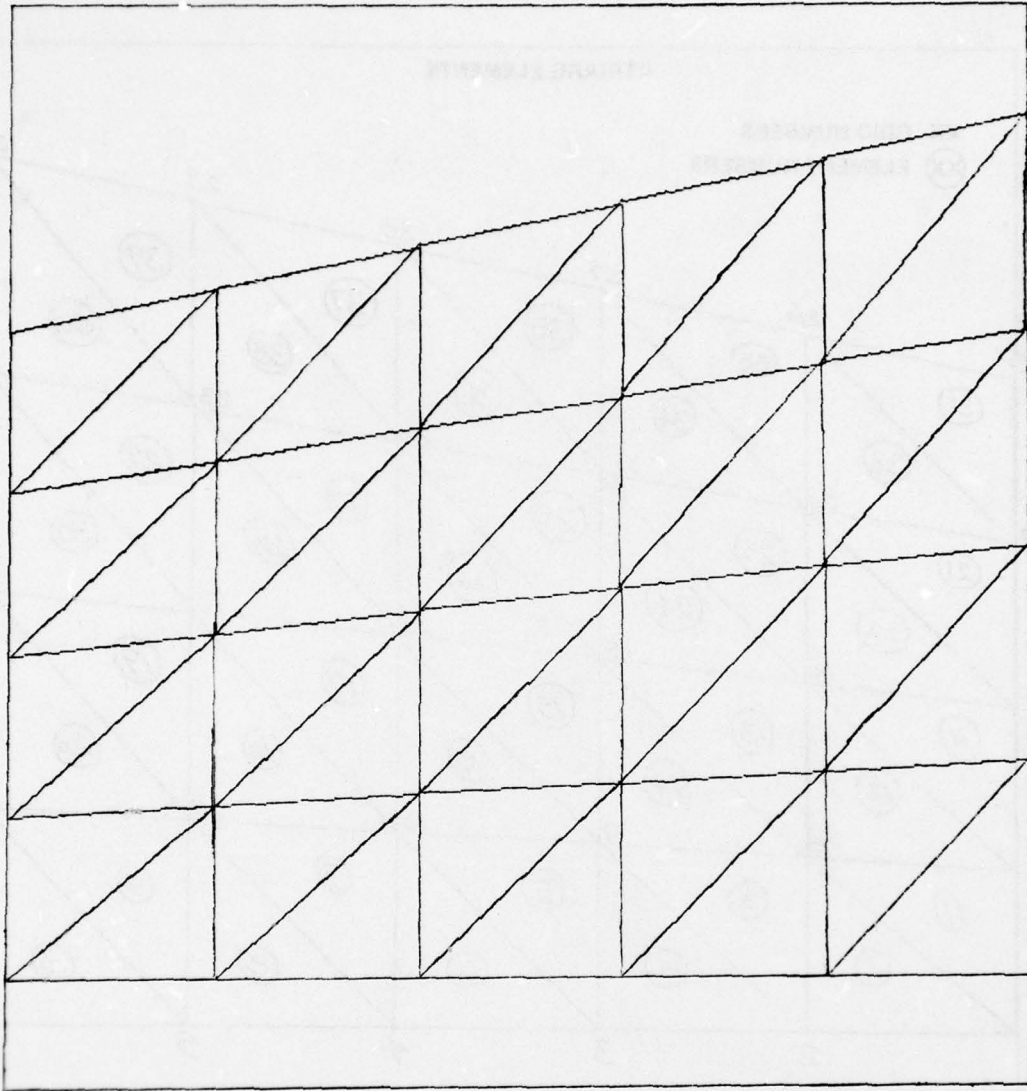

FIG. B-7 NASTRAN STRUCTURAL PLOT

LISTING OF PUNCHED NASTRAN BULK DATA CARDS  
PROBLEM B-I-B AXISYMMETRIC RING ELEMENTS

```
*****  
*****  
**  
** JUNCTION INPUT GENERATOR PROGRAM (JIG) **  
**  
*****  
*****
```

\*\*\* SAMPLE 1 - AXISYMMETRIC RING ELEMENTS \*\*\*

```
NST = 1  
NGS = 1  
NES = 1  
NPOP = 1  
MID = 5  
NGP = 0  
IDELT = 0  
NSECT = 1  
NT( 1) = 1 DELTZ( 1) = 0.0000
```

NSWC/WOL TR 77-85

	I	J	Z(I,J)	X(I,J)	CODE(I,J)		
	1	1	0.00000	1.00000	1		
	2	1	1.00000	1.00000	1		
	3	1	2.00000	1.00000	1		
	4	1	3.00000	1.00000	1		
	5	1	4.00000	1.00000	1		
	6	1	5.00000	1.00000	1		
	1	2	0.00000	1.75000	1		
	2	2	1.00000	1.79999	0		
	3	2	2.00001	1.85002	0		
	4	2	3.00002	1.90000	0		
	5	2	3.99999	1.94998	0		
	6	2	5.00000	2.00000	1		
	1	3	0.00000	2.50000	1		
	2	3	1.00003	2.60002	0		
	3	3	2.00002	2.70002	0		
	4	3	3.00000	2.79999	0		
	5	3	4.00000	2.90000	0		
	6	3	5.00000	3.00000	1		
	1	4	0.00000	3.25000	1		
	2	4	1.00002	3.40002	0		
	3	4	1.99998	3.54999	0		
	4	4	3.00000	3.70000	0		
	5	4	4.00000	3.84999	0		
	6	4	5.00000	4.00000	1		
	1	5	0.00000	4.00000	1		
	2	5	1.00000	4.20000	1		
	3	5	2.00000	4.40000	1		
	4	5	3.00000	4.60000	1		
	5	5	4.00000	4.80000	1		
	6	5	5.00000	5.00000	1		
GRID	1	0	1.0000	0.0000	0.0000	0	456
GRID	2	0	1.0000	0.0000	1.0000	0	456
GRID	3	0	1.0000	0.0000	2.0000	0	456
GRID	4	0	1.0000	0.0000	3.0000	0	456
GRID	5	0	1.0000	0.0000	4.0000	0	456
GRID	6	0	1.0000	0.0000	5.0000	0	456
GRID	7	0	1.7500	0.0000	0.0000	0	456
GRID	8	0	1.8000	0.0000	1.0000	0	456
CTRIARG	1	8	7	1	0.0000	5	
CTRIARG	2	1	2	8	0.0000	5	
GRID	9	0	1.8500	0.0000	2.0000	0	456
CTRIARG	3	9	8	2	0.0000	5	
CTRIARG	4	2	3	9	0.0000	5	
GRID	10	0	1.9000	0.0000	3.0000	0	456
CTRIARG	5	10	9	3	0.0000	5	
CTRIARG	6	3	4	10	0.0000	5	
GRID	11	0	1.9500	0.0000	4.0000	0	456
CTRIARG	7	11	10	4	0.0000	5	
CTRIARG	8	4	5	11	0.0000	5	
GRID	12	0	2.0000	0.0000	5.0000	0	456
CTRIARG	9	12	11	5	0.0000	5	
CTRIARG	10	5	6	12	0.0000	5	
GRID	13	0	2.5000	0.0000	0.0000	0	456
GRID	14	0	2.6000	0.0000	1.0000	0	456
CTRIARG	11	14	13	7	0.0000	5	
CTRIARG	12	7	8	14	0.0000	5	
GRID	15	0	2.7000	0.0000	2.0000	0	456
CTRIARG	13	15	14	8	0.0000	5	

## NSWC/WOL TR 77-85

CTRIARG	14	8	9	15	0.0000	5	
GRID	16	0	2.8000	0.0000	3.0000	0	456
CTRIARG	15	16	15	9	0.0000	5	
CTRIARG	16	9	10	16	0.0000	5	
GRID	17	0	2.9000	0.0000	4.0000	0	456
CTRIARG	17	17	16	10	0.0000	5	
CTRIARG	18	10	11	17	0.0000	5	
GRID	18	0	3.0000	0.0000	5.0000	0	456
CTRIARG	19	18	17	11	0.0000	5	
CTRIARG	20	11	12	18	0.0000	5	
GRID	19	0	3.2500	0.0000	0.0000	0	456
GRID	20	0	3.4000	0.0000	1.0000	0	456
CTRIARG	21	20	19	13	0.0000	5	
CTRIARG	22	13	14	20	0.0000	5	
GRID	21	0	3.5500	0.0000	2.0000	0	456
CTRIARG	23	21	20	14	0.0000	5	
CTRIARG	24	14	15	21	0.0000	5	
GRID	22	0	3.7000	0.0000	3.0000	0	456
CTRIARG	25	22	21	15	0.0000	5	
CTRIARG	26	15	16	22	0.0000	5	
GRID	23	0	3.8500	0.0000	4.0000	0	456
CTRIARG	27	23	22	16	0.0000	5	
CTRIARG	28	16	17	23	0.0000	5	
GRID	24	0	4.0000	0.0000	5.0000	0	456
CTRIARG	29	24	23	17	0.0000	5	
CTRIARG	30	17	18	24	0.0000	5	
GRID	25	0	4.0000	0.0000	0.0000	0	456
GRID	26	0	4.2000	0.0000	1.0000	0	456
CTRIARG	31	26	25	19	0.0000	5	
CTRIARG	32	19	20	26	0.0000	5	
GRID	27	0	4.4000	0.0000	2.0000	0	456
CTRIARG	33	27	26	20	0.0000	5	
CTRIARG	34	20	21	27	0.0000	5	
GRID	28	0	4.6000	0.0000	3.0000	0	456
CTRIARG	35	28	27	21	0.0000	5	
CTRIARG	36	21	22	28	0.0000	5	
GRID	29	0	4.8000	0.0000	4.0000	0	456
CTRIARG	37	29	28	22	0.0000	5	
CTRIARG	38	22	23	29	0.0000	5	
GRID	30	0	5.0000	0.0000	5.0000	0	456
CTRIARG	39	30	29	23	0.0000	5	
CTRIARG	40	23	24	30	0.0000	5	

\*\*\* SAMPLE 1 - 3D SOLID ELEMENTS \*\*\*

1	1	1	3	5	0	1	1							
1														
0.0														
1	1	100												
1	0.0		7	180.0										
0.0		180.0												
1	5													
4	1	5	1	6	0	0	0	0	0	456	0			
1	1	0.0		1.0		1	6	1	5.0		1.0			1
6	5	5.0		5.0		1	1	5	0.0		4.0			1

FIG. B-8 DATA INPUT PROBLEM B-I-C

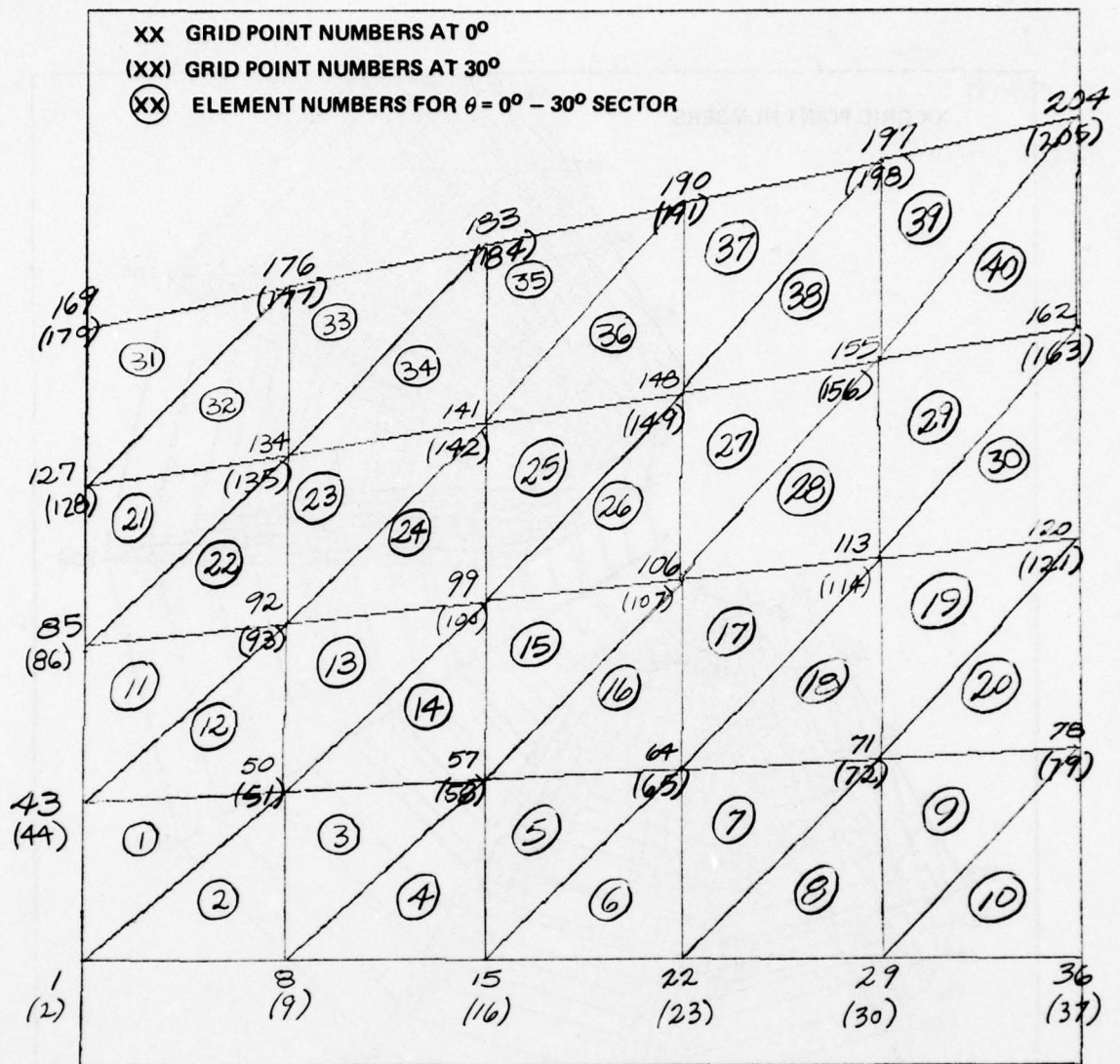
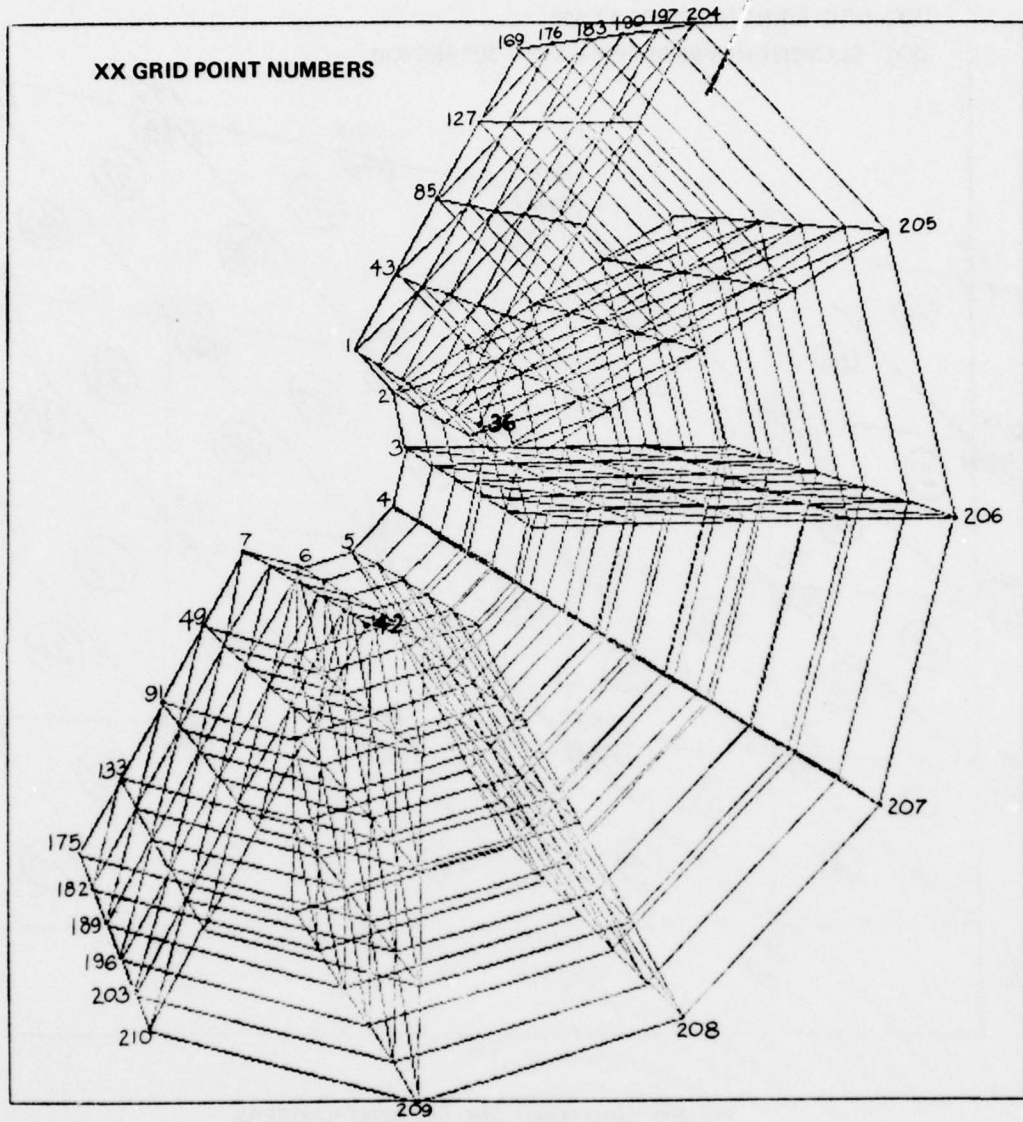
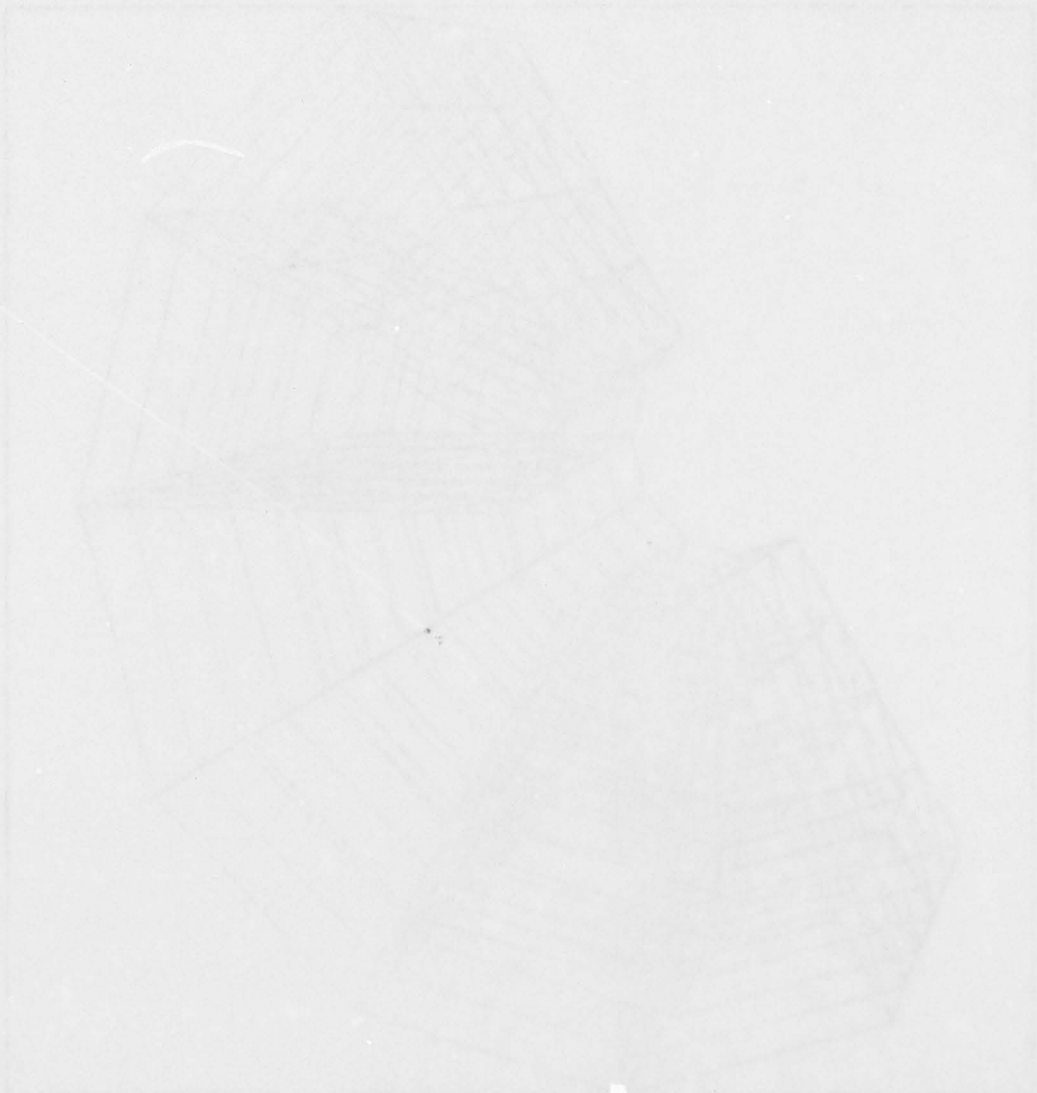

FIG. B-9 GRID POINT AND ELEMENT NUMBERS



**FIG. B-10 GRID POINT NUMBERS**

the grid point and element identification numbers as generated by JIG. Figure B-11 gives the structural plot of the finite element model followed by a listing of the JIG punched output.



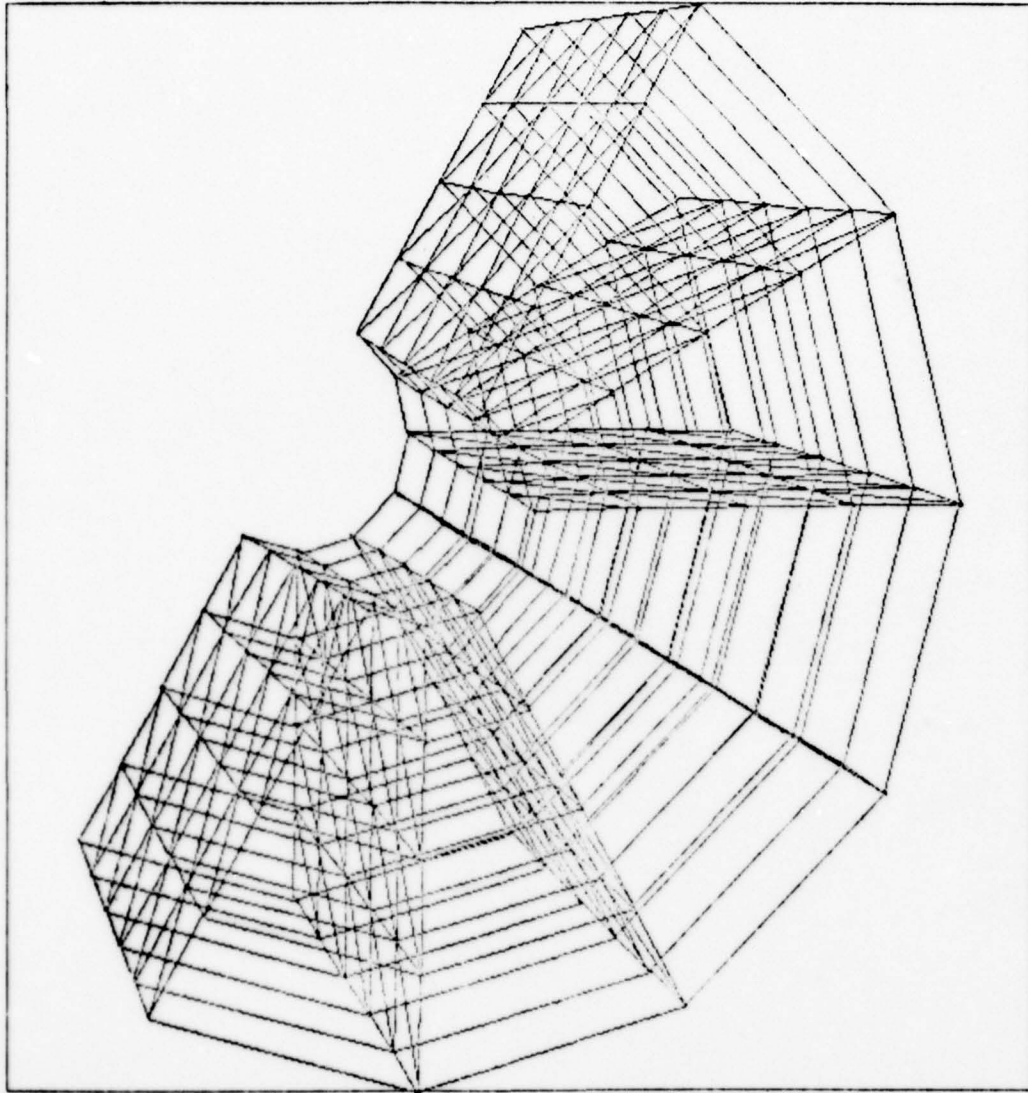

FIG. B-11 NASTRAN STRUCTURAL PLOT

LISTING OF PUNCHED NASTRAN BULK DATA CARDS  
PROBLEM B-I-C 3-D SOLID ELEMENTS

```
*****  
*****  
**  
** JUNCTION INPUT GENERATOR PROGRAM (JIG) **  
**  
*****  
*****
```

## \*\*\* SAMPLE 1 - 3D SOLID ELEMENTS \*\*\*

```
NST = 1  
NGS = 1  
NES = 1  
NPOP = 3  
MIJ = 5  
NGP = 0  
IDELT = 1  
NSECT = 1  
NT( 1) = 1 DELTZ( 1) = 0.0000  
NDT = 1  
ICLOSE = 1  
DELGP = 100  
KK( 1) = 1 THETA( 1) = 0.0000  
KK( 2) = 7 THETA( 2) = 180.0000  
BETA( 1) = 0.0000  
BETA( 2) = 180.0000  
JB( 1) = 1 JE( 1) = 5
```

NSWC/WOL TR 77-85

I	J	Z(I,J)	X(I,J)	CODE(I,J)			
1	1	0.00000	1.00000	1			
2	1	1.00000	1.00000	1			
3	1	2.00000	1.00000	1			
4	1	3.00000	1.00000	1			
5	1	4.00000	1.00000	1			
6	1	5.00000	1.00000	1			
1	2	0.00000	1.75000	1			
2	2	1.00000	1.79999	0			
3	2	2.00001	1.85002	0			
4	2	3.00002	1.90000	0			
5	2	3.99999	1.94998	0			
6	2	5.00000	2.00000	1			
1	3	0.00000	2.50000	1			
2	3	1.00003	2.60002	0			
3	3	2.00002	2.70002	0			
4	3	3.00000	2.79999	0			
5	3	4.00000	2.90000	0			
6	3	5.00000	3.00000	1			
1	4	0.00000	3.25000	1			
2	4	1.00002	3.40002	0			
3	4	1.99998	3.54999	0			
4	4	3.00000	3.70000	0			
5	4	4.00000	3.84999	0			
6	4	5.00000	4.00000	1			
1	5	0.00000	4.00000	1			
2	5	1.00000	4.20000	1			
3	5	2.00000	4.40000	1			
4	5	3.00000	4.60000	1			
5	5	4.00000	4.80000	1			
6	5	5.00000	5.00000	1			
GRID		1	1.0000	0.0000	0.0000	1	456
GRID		2	1.0000	30.0000	0.0000	1	456
GRID		3	1.0000	60.0000	0.0000	1	456
GRID		4	1.0000	90.0000	0.0000	1	456
GRID		5	1.0000	120.0000	0.0000	1	456
GRID		6	1.0000	150.0000	0.0000	1	456
GRID		7	1.0000	180.0000	0.0000	1	456
GRID		8	1.0000	0.0000	1.0000	1	456
GRID		9	1.0000	30.0000	1.0000	1	456
GRID		10	1.0000	60.0000	1.0000	1	456
GRID		11	1.0000	90.0000	1.0000	1	456
GRID		12	1.0000	120.0000	1.0000	1	456
GRID		13	1.0000	150.0000	1.0000	1	456
GRID		14	1.0000	180.0000	1.0000	1	456
GRID		15	1.0000	0.0000	2.0000	1	456
GRID		16	1.0000	30.0000	2.0000	1	456
GRID		17	1.0000	60.0000	2.0000	1	456
GRID		18	1.0000	90.0000	2.0000	1	456
GRID		19	1.0000	120.0000	2.0000	1	456
GRID		20	1.0000	150.0000	2.0000	1	456
GRID		21	1.0000	180.0000	2.0000	1	456
GRID		22	1.0000	0.0000	3.0000	1	456
GRID		23	1.0000	30.0000	3.0000	1	456
GRID		24	1.0000	60.0000	3.0000	1	456
GRID		25	1.0000	90.0000	3.0000	1	456
GRID		26	1.0000	120.0000	3.0000	1	456
GRID		27	1.0000	150.0000	3.0000	1	456
GRID		28	1.0000	180.0000	3.0000	1	456

NSWC/WOL TR 77-85

GRID	29	1	1.0000	0.0000	4.0000	1	456	
GRID	30	1	1.0000	30.0000	4.0000	1	456	
GRID	31	1	1.0000	60.0000	4.0000	1	456	
GRID	32	1	1.0000	90.0000	4.0000	1	456	
GRID	33	1	1.0000	120.0000	4.0000	1	456	
GRID	34	1	1.0000	150.0000	4.0000	1	456	
GRID	35	1	1.0000	180.0000	4.0000	1	456	
GRID	36	1	1.0000	0.0000	5.0000	1	456	
GRID	37	1	1.0000	30.0000	5.0000	1	456	
GRID	38	1	1.0000	60.0000	5.0000	1	456	
GRID	39	1	1.0000	90.0000	5.0000	1	456	
GRID	40	1	1.0000	120.0000	5.0000	1	456	
GRID	41	1	1.0000	150.0000	5.0000	1	456	
GRID	42	1	1.0000	180.0000	5.0000	1	456	
GRID	43	1	1.7500	0.0000	0.0000	1	456	
GRID	44	1	1.7500	30.0000	0.0000	1	456	
GRID	45	1	1.7500	60.0000	0.0000	1	456	
GRID	46	1	1.7500	90.0000	0.0000	1	456	
GRID	47	1	1.7500	120.0000	0.0000	1	456	
GRID	48	1	1.7500	150.0000	0.0000	1	456	
GRID	49	1	1.7500	180.0000	0.0000	1	456	
GRID	50	1	1.8000	0.0000	1.0000	1	456	
GRID	51	1	1.8000	30.0000	1.0000	1	456	
GRID	52	1	1.8000	60.0000	1.0000	1	456	
GRID	53	1	1.8000	90.0000	1.0000	1	456	
GRID	54	1	1.8000	120.0000	1.0000	1	456	
GRID	55	1	1.8000	150.0000	1.0000	1	456	
GRID	56	1	1.8000	180.0000	1.0000	1	456	
CWEDGE	1	5	50	43	1	51	44	2
CWEDGE	101	5	51	44	2	52	45	3
CWEDGE	201	5	52	45	3	53	46	4
CWEDGE	301	5	53	46	4	54	47	5
CWEDGE	401	5	54	47	5	55	48	6
CWEDGE	501	5	55	48	6	56	49	7
CWEDGE	2	5	1	8	50	2	9	51
CWEDGE	102	5	2	9	51	3	10	52
CWEDGE	202	5	3	10	52	4	11	53
CWEDGE	302	5	4	11	53	5	12	54
CWEDGE	402	5	5	12	54	6	13	55
CWEDGE	502	5	6	13	55	7	14	56
GRID	57	1	1.8500	0.0000	2.0000	1	456	
GRID	58	1	1.8500	30.0000	2.0000	1	456	
GRID	59	1	1.8500	60.0000	2.0000	1	456	
GRID	60	1	1.8500	90.0000	2.0000	1	456	
GRID	61	1	1.8500	120.0000	2.0000	1	456	
GRID	62	1	1.8500	150.0000	2.0000	1	456	
GRID	63	1	1.8500	180.0000	2.0000	1	456	
CWEDGE	3	5	57	50	8	58	51	9
CWEDGE	103	5	58	51	9	59	52	10
CWEDGE	203	5	59	52	10	60	53	11
CWEDGE	303	5	60	53	11	61	54	12
CWEDGE	403	5	61	54	12	62	55	13
CWEDGE	503	5	62	55	13	63	56	14
CWEDGE	4	5	8	15	57	9	16	58
CWEDGE	104	5	9	16	58	10	17	59
CWEDGE	204	5	10	17	59	11	18	60
CWEDGE	304	5	11	18	60	12	19	61
CWEDGE	404	5	12	19	61	13	20	62
CWEDGE	504	5	13	20	62	14	21	63
GRID	64	1	1.9000	0.0000	3.0000	1	456	
GRID	65	1	1.9000	30.0000	3.0000	1	456	
GRID	66	1	1.9000	60.0000	3.0000	1	456	
GRID	67	1	1.9000	90.0000	3.0000	1	456	
GRID	68	1	1.9000	120.0000	3.0000	1	456	

NSWC/WOL TR 77-85

GRID	69	1	1.9000	150.0000	3.0000	1	456	
GRID	70	1	1.9000	180.0000	3.0000	1	456	
CWEDGE	5	5	64	57	15	65	58	15
CWEDGE	105	5	65	58	16	66	59	17
CWEDGE	205	5	66	59	17	67	60	18
CWEDGE	305	5	67	60	18	68	61	19
CWEDGE	405	5	68	61	19	69	62	20
CWEDGE	505	5	69	62	20	70	63	21
CWEDGE	6	5	15	22	64	16	23	65
CWEDGE	106	5	16	23	65	17	24	66
CWEDGE	206	5	17	24	66	18	25	67
CWEDGE	306	5	18	25	67	19	26	68
CWEDGE	406	5	19	26	68	20	27	69
CWEDGE	506	5	20	27	69	21	28	70
GRID	71	1	1.9500	0.0000	4.0000	1	456	
GRID	72	1	1.9500	30.0000	4.0000	1	456	
GRID	73	1	1.9500	60.0000	4.0000	1	456	
GRID	74	1	1.9500	90.0000	4.0000	1	456	
GRID	75	1	1.9500	120.0000	4.0000	1	456	
GRID	76	1	1.9500	150.0000	4.0000	1	456	
GRID	77	1	1.9500	180.0000	4.0000	1	456	
CWEDGE	7	5	71	64	22	72	65	23
CWEDGE	107	5	72	65	23	73	66	24
CWEDGE	207	5	73	66	24	74	67	25
CWEDGE	307	5	74	67	25	75	68	26
CWEDGE	407	5	75	68	26	76	69	27
CWEDGE	507	5	76	69	27	77	70	28
CWEDGE	8	5	22	29	71	23	30	72
CWEDGE	108	5	23	30	72	24	31	73
CWEDGE	208	5	24	31	73	25	32	74
CWEDGE	308	5	25	32	74	26	33	75
CWEDGE	408	5	26	33	75	27	34	76
CWEDGE	508	5	27	34	76	28	35	77
GRID	78	1	2.0000	0.0000	5.0000	1	456	
GRID	79	1	2.0000	30.0000	5.0000	1	456	
GRID	80	1	2.0000	60.0000	5.0000	1	456	
GRID	81	1	2.0000	90.0000	5.0000	1	456	
GRID	82	1	2.0000	120.0000	5.0000	1	456	
GRID	83	1	2.0000	150.0000	5.0000	1	456	
GRID	84	1	2.0000	180.0000	5.0000	1	456	
CWEDGE	9	5	78	71	29	79	72	30
CWEDGE	109	5	79	72	30	80	73	31
CWEDGE	209	5	80	73	31	81	74	32
CWEDGE	309	5	81	74	32	82	75	33
CWEDGE	409	5	82	75	33	83	76	34
CWEDGE	509	5	83	76	34	84	77	35
CWEDGE	10	5	29	36	78	30	37	79
CWEDGE	110	5	30	37	79	31	38	80
CWEDGE	210	5	31	38	80	32	39	81
CWEDGE	310	5	32	39	81	33	40	82
CWEDGE	410	5	33	40	82	34	41	83
CWEDGE	510	5	34	41	83	35	42	84
GRID	85	1	2.5000	0.0000	0.0000	1	456	
GRID	86	1	2.5000	30.0000	0.0000	1	456	
GRID	87	1	2.5000	60.0000	0.0000	1	456	
GRID	88	1	2.5000	90.0000	0.0000	1	456	
GRID	89	1	2.5000	120.0000	0.0000	1	456	
GRID	90	1	2.5000	150.0000	0.0000	1	456	
GRID	91	1	2.5000	180.0000	0.0000	1	456	
GRID	92	1	2.6000	0.0000	1.0000	1	456	
GRID	93	1	2.6000	30.0000	1.0000	1	456	
GRID	94	1	2.6000	60.0000	1.0000	1	456	
GRID	95	1	2.6000	90.0000	1.0000	1	456	
GRID	96	1	2.6000	120.0000	1.0000	1	456	

NSWC/WOL TR 77-85

GRID	97	1	2.6000	150.0000	1.0000	1	456	
GRID	98	1	2.6000	180.0000	1.0000	1	456	
CWEDGE	11	5	92	85	43	93	86	44
CWEDGE	111	5	93	86	44	94	87	45
CWEDGE	211	5	94	87	45	95	88	46
CWEDGE	311	5	95	88	46	96	89	47
CWEDGE	411	5	96	89	47	97	90	48
CWEDGE	511	5	97	90	48	98	91	49
CWEDGE	12	5	43	50	92	44	51	93
CWEDGE	112	5	44	51	93	45	52	94
CWEDGE	212	5	45	52	94	46	53	95
CWEDGE	312	5	46	53	95	47	54	96
CWEDGE	412	5	47	54	96	48	55	97
CWEDGE	512	5	48	55	97	49	56	98
GRID	99	1	2.7000	0.0000	2.0000	1	456	
GRID	100	1	2.7000	30.0000	2.0000	1	456	
GRID	101	1	2.7000	60.0000	2.0000	1	456	
GRID	102	1	2.7000	90.0000	2.0000	1	456	
GRID	103	1	2.7000	120.0000	2.0000	1	456	
GRID	104	1	2.7000	150.0000	2.0000	1	456	
GRID	105	1	2.7000	180.0000	2.0000	1	456	
CWEDGE	13	5	99	92	50	100	93	51
CWEDGE	113	5	100	93	51	101	94	52
CWEDGE	213	5	101	94	52	102	95	53
CWEDGE	313	5	102	95	53	103	96	54
CWEDGE	413	5	103	96	54	104	97	55
CWEDGE	513	5	104	97	55	105	98	56
CWEDGE	14	5	50	57	99	51	58	100
CWEDGE	114	5	51	58	100	52	59	101
CWEDGE	214	5	52	59	101	53	60	102
CWEDGE	314	5	53	60	102	54	61	103
CWEDGE	414	5	54	61	103	55	62	104
CWEDGE	514	5	55	62	104	56	63	105
GRID	106	1	2.8000	0.0000	3.0000	1	456	
GRID	107	1	2.8000	30.0000	3.0000	1	456	
GRID	108	1	2.8000	60.0000	3.0000	1	456	
GRID	109	1	2.8000	90.0000	3.0000	1	456	
GRID	110	1	2.8000	120.0000	3.0000	1	456	
GRID	111	1	2.8000	150.0000	3.0000	1	456	
GRID	112	1	2.8000	180.0000	3.0000	1	456	
CWEDGE	15	5	106	99	57	107	100	58
CWEDGE	115	5	107	100	58	108	101	59
CWEDGE	215	5	108	101	59	109	102	60
CWEDGE	315	5	109	102	60	110	103	61
CWEDGE	415	5	110	103	61	111	104	62
CWEDGE	515	5	111	104	62	112	105	63
CWEDGE	16	5	57	64	106	58	65	107
CWEDGE	116	5	58	65	107	59	66	108
CWEDGE	216	5	59	66	108	60	67	109
CWEDGE	316	5	60	67	109	61	68	110
CWEDGE	416	5	61	68	110	62	69	111
CWEDGE	516	5	62	69	111	63	70	112
GRID	113	1	2.9000	0.0000	4.0000	1	456	
GRID	114	1	2.9000	30.0000	4.0000	1	456	
GRID	115	1	2.9000	60.0000	4.0000	1	456	
GRID	116	1	2.9000	90.0000	4.0000	1	456	
GRID	117	1	2.9000	120.0000	4.0000	1	456	
GRID	118	1	2.9000	150.0000	4.0000	1	456	
GRID	119	1	2.9000	180.0000	4.0000	1	456	
CWEDGE	17	5	113	106	64	114	107	65
CWEDGE	117	5	114	107	65	115	108	66
CWEDGE	217	5	115	108	66	116	109	67
CWEDGE	317	5	116	109	67	117	110	68
CWEDGE	417	5	117	110	68	118	111	69

AD-A049 663

NAVAL SURFACE WEAPONS CENTER WHITE OAK LAB SILVER SP--ETC F/G 13/13  
JUNCTION INPUT GENERATOR (JIG), A NASTRAN PRE-PROCESSOR; THEORE--ETC(U)  
SEP 77 P C HUANG, K C KIDDY, J P MATRA

UNCLASSIFIED

NSWC/WOL/TR-77-85

NL

2 OF 3  
AD  
A049663

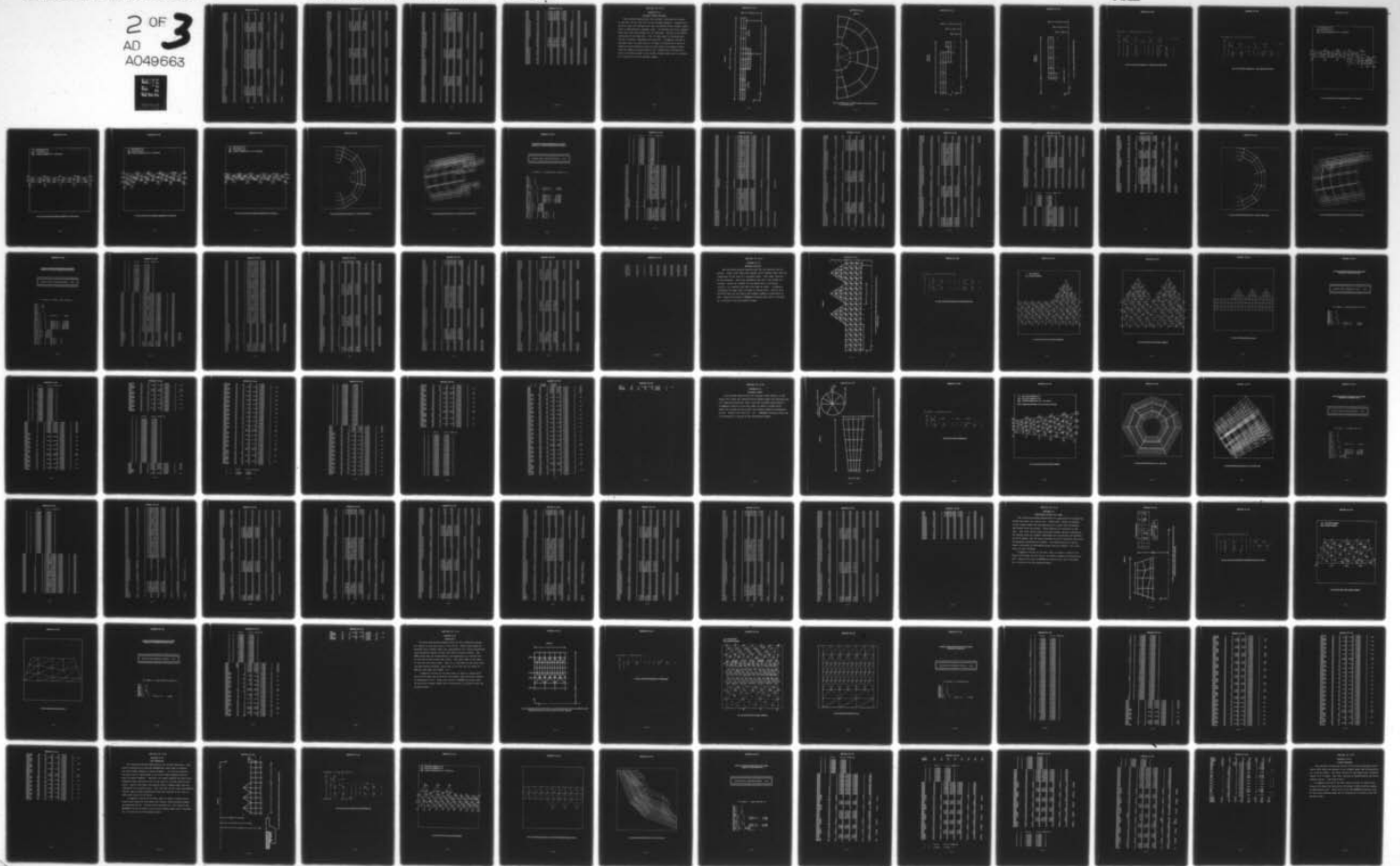

NSWC/WOL TR 77-85

CWEDGE	517	5	118	111	69	119	112	70
CWEDGE	18	5	64	71	113	65	72	114
CWEDGE	118	5	65	72	114	66	73	115
CWEDGE	218	5	66	73	115	67	74	116
CWEDGE	318	5	67	74	116	68	75	117
CWEDGE	418	5	68	75	117	69	76	118
CWEDGE	518	5	69	76	118	70	77	119
GRID	120	1	3.0000	0.0000	5.0000	1	456	
GRID	121	1	3.0000	30.0000	5.0000	1	456	
GRID	122	1	3.0000	60.0000	5.0000	1	456	
GRID	123	1	3.0000	90.0000	5.0000	1	456	
GRID	124	1	3.0000	120.0000	5.0000	1	456	
GRID	125	1	3.0000	150.0000	5.0000	1	456	
GRID	126	1	3.0000	180.0000	5.0000	1	456	
CWEDGE	19	5	120	113	71	121	114	72
CWEDGE	119	5	121	114	72	122	115	73
CWEDGE	219	5	122	115	73	123	116	74
CWEDGE	319	5	123	116	74	124	117	75
CWEDGE	419	5	124	117	75	125	118	76
CWEDGE	519	5	125	118	76	126	119	77
CWEDGE	20	5	71	78	120	72	79	121
CWEDGE	120	5	72	79	121	73	80	122
CWEDGE	220	5	73	80	122	74	81	123
CWEDGE	320	5	74	81	123	75	82	124
CWEDGE	420	5	75	82	124	76	83	125
CWEDGE	520	5	76	83	125	77	84	126
GRID	127	1	3.2500	0.0000	0.0000	1	456	
GRID	128	1	3.2500	30.0000	0.0000	1	456	
GRID	129	1	3.2500	60.0000	0.0000	1	456	
GRID	130	1	3.2500	90.0000	0.0000	1	456	
GRID	131	1	3.2500	120.0000	0.0000	1	456	
GRID	132	1	3.2500	150.0000	0.0000	1	456	
GRID	133	1	3.2500	180.0000	0.0000	1	456	
GRID	134	1	3.4000	0.0000	1.0000	1	456	
GRID	135	1	3.4000	30.0000	1.0000	1	456	
GRID	136	1	3.4000	60.0000	1.0000	1	456	
GRID	137	1	3.4000	90.0000	1.0000	1	456	
GRID	138	1	3.4000	120.0000	1.0000	1	456	
GRID	139	1	3.4000	150.0000	1.0000	1	456	
GRID	140	1	3.4000	180.0000	1.0000	1	456	
CWEDGE	21	5	134	127	85	135	128	86
CWEDGE	121	5	135	128	86	136	129	87
CWEDGE	221	5	136	129	87	137	130	88
CWEDGE	321	5	137	130	88	138	131	89
CWEDGE	421	5	138	131	89	139	132	90
CWEDGE	521	5	139	132	90	140	133	91
CWEDGE	22	5	85	92	134	86	93	135
CWEDGE	122	5	86	93	135	87	94	136
CWEDGE	222	5	87	94	136	88	95	137
CWEDGE	322	5	88	95	137	89	96	138
CWEDGE	422	5	89	96	138	90	97	139
CWEDGE	522	5	90	97	139	91	98	140
GRID	141	1	3.5500	0.0000	2.0000	1	456	
GRID	142	1	3.5500	30.0000	2.0000	1	456	
GRID	143	1	3.5500	60.0000	2.0000	1	456	
GRID	144	1	3.5500	90.0000	2.0000	1	456	
GRID	145	1	3.5500	120.0000	2.0000	1	456	
GRID	146	1	3.5500	150.0000	2.0000	1	456	
GRID	147	1	3.5500	180.0000	2.0000	1	456	
CWEDGE	23	5	141	134	92	142	135	93
CWEDGE	123	5	142	135	93	143	136	94
CWEDGE	223	5	143	136	94	144	137	95
CWEDGE	323	5	144	137	95	145	138	96
CWEDGE	423	5	145	138	96	146	139	97

NSWC/WOL TR 77-85

CWEDGE	523	5	146	139	97	147	140	98
CWEDGE	24	5	92	99	141	93	100	142
CWEDGE	124	5	93	100	142	94	101	143
CWEDGE	224	5	94	101	143	95	102	144
CWEDGE	324	5	95	102	144	96	103	145
CWEDGE	424	5	96	103	145	97	104	146
CWEDGE	524	5	97	104	146	98	105	147
GRID	148	1	3.7000	0.0000	3.0000	1	456	
GRID	149	1	3.7000	30.0000	3.0000	1	456	
GRID	150	1	3.7000	60.0000	3.0000	1	456	
GRID	151	1	3.7000	90.0000	3.0000	1	456	
GRID	152	1	3.7000	120.0000	3.0000	1	456	
GRID	153	1	3.7000	150.0000	3.0000	1	456	
GRID	154	1	3.7000	180.0000	3.0000	1	456	
CWEDGE	25	5	148	141	99	149	142	100
CWEDGE	125	5	149	142	100	150	143	101
CWEDGE	225	5	150	143	101	151	144	102
CWEDGE	325	5	151	144	102	152	145	103
CWEDGE	425	5	152	145	103	153	146	104
CWEDGE	525	5	153	146	104	154	147	105
CWEDGE	26	5	99	106	148	100	107	149
CWEDGE	126	5	100	107	149	101	108	150
CWEDGE	226	5	101	108	150	102	109	151
CWEDGE	326	5	102	109	151	103	110	152
CWEDGE	426	5	103	110	152	104	111	153
CWEDGE	526	5	104	111	153	105	112	154
GRID	155	1	3.8500	0.0000	4.0000	1	456	
GRID	156	1	3.8500	30.0000	4.0000	1	456	
GRID	157	1	3.8500	60.0000	4.0000	1	456	
GRID	158	1	3.8500	90.0000	4.0000	1	456	
GRID	159	1	3.8500	120.0000	4.0000	1	456	
GRID	160	1	3.8500	150.0000	4.0000	1	456	
GRID	161	1	3.8500	180.0000	4.0000	1	456	
CWEDGE	27	5	155	148	106	156	149	107
CWEDGE	127	5	156	149	107	157	150	108
CWEDGE	227	5	157	150	108	158	151	109
CWEDGE	327	5	158	151	109	159	152	110
CWEDGE	427	5	159	152	110	160	153	111
CWEDGE	527	5	160	153	111	161	154	112
CWEDGE	28	5	106	113	155	107	114	156
CWEDGE	128	5	107	114	156	108	115	157
CWEDGE	228	5	108	115	157	109	116	158
CWEDGE	328	5	109	116	158	110	117	159
CWEDGE	428	5	110	117	159	111	118	160
CWEDGE	528	5	111	118	160	112	119	161
GRID	162	1	4.0000	0.0000	5.0000	1	456	
GRID	163	1	4.0000	30.0000	5.0000	1	456	
GRID	164	1	4.0000	60.0000	5.0000	1	456	
GRID	165	1	4.0000	90.0000	5.0000	1	456	
GRID	166	1	4.0000	120.0000	5.0000	1	456	
GRID	167	1	4.0000	150.0000	5.0000	1	456	
GRID	168	1	4.0000	180.0000	5.0000	1	456	
CWEDGE	29	5	162	155	113	163	156	114
CWEDGE	129	5	163	156	114	164	157	115
CWEDGE	229	5	164	157	115	165	158	116
CWEDGE	329	5	165	158	116	166	159	117
CWEDGE	429	5	166	159	117	167	160	118
CWEDGE	529	5	167	160	118	168	161	119
CWEDGE	30	5	113	120	162	114	121	163
CWEDGE	130	5	114	121	163	115	122	164
CWEDGE	230	5	115	122	164	116	123	165
CWEDGE	330	5	116	123	165	117	124	166
CWEDGE	430	5	117	124	166	118	125	167
CWEDGE	530	5	118	125	167	119	126	168

NSWC/WOL TR 77-85

GRID	169	1	4.0000	0.0000	0.0000	1	456	
GRID	170	1	4.0000	30.0000	0.0000	1	456	
GRID	171	1	4.0000	60.0000	0.0000	1	456	
GRID	172	1	4.0000	90.0000	0.0000	1	456	
GRID	173	1	4.0000	120.0000	0.0000	1	456	
GRID	174	1	4.0000	150.0000	0.0000	1	456	
GRID	175	1	4.0000	180.0000	0.0000	1	456	
GRID	176	1	4.2000	0.0000	1.0000	1	456	
GRID	177	1	4.2000	30.0000	1.0000	1	456	
GRID	178	1	4.2000	60.0000	1.0000	1	456	
GRID	179	1	4.2000	90.0000	1.0000	1	456	
GRID	180	1	4.2000	120.0000	1.0000	1	456	
GRID	181	1	4.2000	150.0000	1.0000	1	456	
GRID	182	1	4.2000	180.0000	1.0000	1	456	
CWEDGE	31	5	176	169	127	177	170	128
CWEDGE	131	5	177	170	128	178	171	129
CWEDGE	231	5	178	171	129	179	172	130
CWEDGE	331	5	179	172	130	180	173	131
CWEDGE	431	5	180	173	131	181	174	132
CWEDGE	531	5	181	174	132	182	175	133
CWEDGE	32	5	127	134	176	128	135	177
CWEDGE	132	5	128	135	177	129	136	178
CWEDGE	232	5	129	136	178	130	137	179
CWEDGE	332	5	130	137	179	131	138	180
CWEDGE	432	5	131	138	180	132	139	181
CWEDGE	532	5	132	139	181	133	140	182
GRID	183	1	4.4000	0.0000	2.0000	1	456	
GRID	184	1	4.4000	30.0000	2.0000	1	456	
GRID	185	1	4.4000	60.0000	2.0000	1	456	
GRID	186	1	4.4000	90.0000	2.0000	1	456	
GRID	187	1	4.4000	120.0000	2.0000	1	456	
GRID	188	1	4.4000	150.0000	2.0000	1	456	
GRID	189	1	4.4000	180.0000	2.0000	1	456	
CWEDGE	33	5	183	176	134	184	177	135
CWEDGE	133	5	184	177	135	185	178	136
CWEDGE	233	5	185	178	136	186	179	137
CWEDGE	333	5	186	179	137	187	180	138
CWEDGE	433	5	187	180	138	188	181	139
CWEDGE	533	5	188	181	139	189	182	140
CWEDGE	34	5	134	141	183	135	142	184
CWEDGE	134	5	135	142	184	136	143	185
CWEDGE	234	5	136	143	185	137	144	186
CWEDGE	334	5	137	144	186	138	145	187
CWEDGE	434	5	138	145	187	139	146	188
CWEDGE	534	5	139	146	188	140	147	189
GRID	190	1	4.6000	0.0000	3.0000	1	456	
GRID	191	1	4.6000	30.0000	3.0000	1	456	
GRID	192	1	4.6000	60.0000	3.0000	1	456	
GRID	193	1	4.6000	90.0000	3.0000	1	456	
GRID	194	1	4.6000	120.0000	3.0000	1	456	
GRID	195	1	4.6000	150.0000	3.0000	1	456	
GRID	196	1	4.6000	180.0000	3.0000	1	456	
CWEDGE	35	5	190	183	141	191	184	142
CWEDGE	135	5	191	184	142	192	185	143
CWEDGE	235	5	192	185	143	193	186	144
CWEDGE	335	5	193	186	144	194	187	145
CWEDGE	435	5	194	187	145	195	188	146
CWEDGE	535	5	195	188	146	196	189	147
CWEDGE	36	5	141	148	190	142	149	191
CWEDGE	136	5	142	149	191	143	150	192
CWEDGE	236	5	143	150	192	144	151	193
CWEDGE	336	5	144	151	193	145	152	194
CWEDGE	436	5	145	152	194	146	153	195
CWEDGE	536	5	146	153	195	147	154	196

NSWC/WOL TR 77-85

GRID	197	1	4.8000	0.0000	4.0000	1	456	
GRID	198	1	4.8000	30.0000	4.0000	1	456	
GRID	199	1	4.8000	60.0000	4.0000	1	456	
GRID	200	1	4.8000	90.0000	4.0000	1	456	
GRID	201	1	4.8000	120.0000	4.0000	1	456	
GRID	202	1	4.8000	150.0000	4.0000	1	456	
GRID	203	1	4.8000	180.0000	4.0000	1	456	
CWEDGE	37	5	197	190	148	198	191	149
CWEDGE	137	5	198	191	149	199	192	150
CWEDGE	237	5	199	192	150	200	193	151
CWEDGE	337	5	200	193	151	201	194	152
CWEDGE	437	5	201	194	152	202	195	153
CWEDGE	537	5	202	195	153	203	196	154
CWEDGE	38	5	148	155	197	149	156	198
CWEDGE	138	5	149	156	198	150	157	199
CWEDGE	238	5	150	157	199	151	158	200
CWEDGE	338	5	151	158	200	152	159	201
CWEDGE	438	5	152	159	201	153	160	202
CWEDGE	538	5	153	160	202	154	161	203
GRID	204	1	5.0000	0.0000	5.0000	1	456	
GRID	205	1	5.0000	30.0000	5.0000	1	456	
GRID	206	1	5.0000	60.0000	5.0000	1	456	
GRID	207	1	5.0000	90.0000	5.0000	1	456	
GRID	208	1	5.0000	120.0000	5.0000	1	456	
GRID	209	1	5.0000	150.0000	5.0000	1	456	
GRID	210	1	5.0000	180.0000	5.0000	1	456	
CWEDGE	39	5	204	197	155	205	198	156
CWEDGE	139	5	205	198	156	206	199	157
CWEDGE	239	5	206	199	157	207	200	158
CWEDGE	339	5	207	200	158	208	201	159
CWEDGE	439	5	208	201	159	209	202	160
CWEDGE	539	5	209	202	160	210	203	161
CWEDGE	40	5	155	162	204	156	163	205
CWEDGE	140	5	156	163	205	157	164	206
CWEDGE	240	5	157	164	206	158	165	207
CWEDGE	340	5	158	165	207	159	166	208
CWEDGE	440	5	159	166	208	160	167	209
CWEDGE	540	5	160	167	209	161	168	210

## PROBLEM B-II

## VARIABLE CROSS-SECTIONS

This problem demonstrates the variable cross-section feature of JIG and its use with the 3-D solid wedge elements. Figures B-12 and B-13 show the configuration and the planned finite element model used in representing a bayonet joint. To develop the finite element model the joint was broken into two sections. Section A the female and Section B the male part. The I-J mesh used in defining each section is shown in Figures B-14 and B-15. A complete listing of the data input for each section is shown in Figures B-16 and B-17. Figures B-18 through B-21 show the grid point and element identification numbers as generated by JIG. Figures B-22 through B-25 gives a structural plot of the finite element model and is followed by a listing of the JIG punched output.

SAMPLE 2

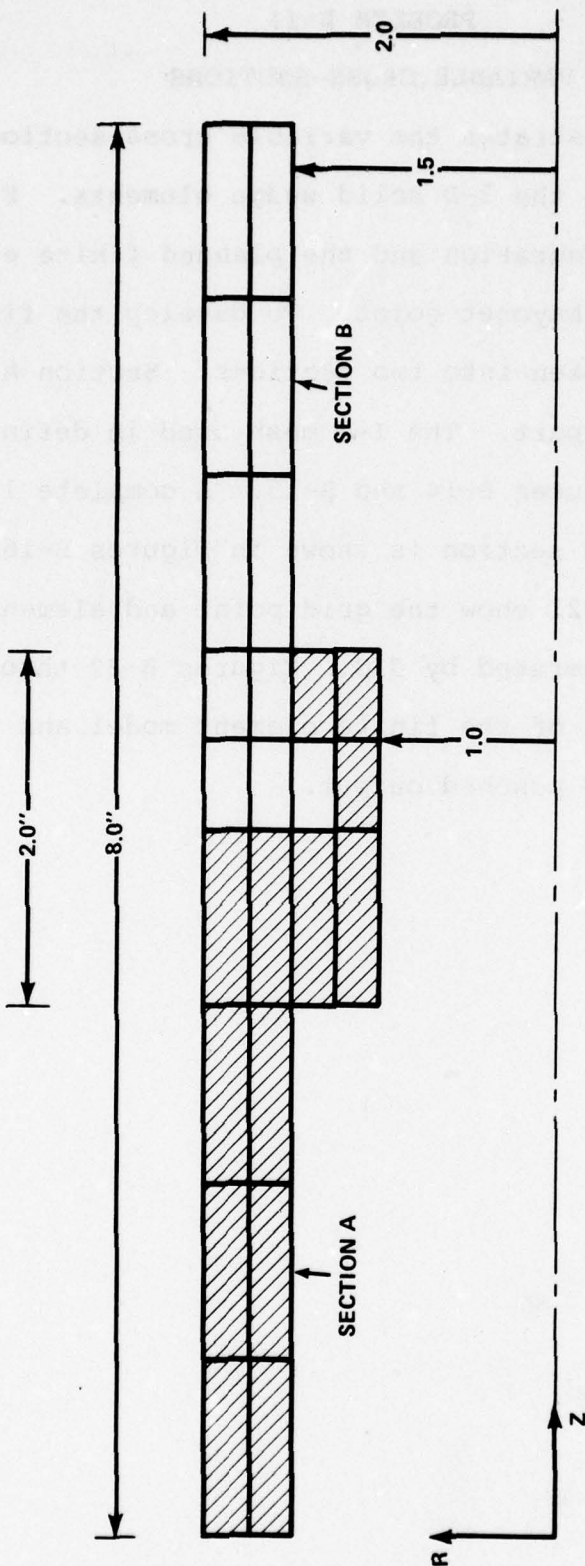

FIG. B-12 PLANNED FINITE ELEMENT MODEL AND CONFIGURATION OF A BAYONET JOINT.

SAMPLE 2

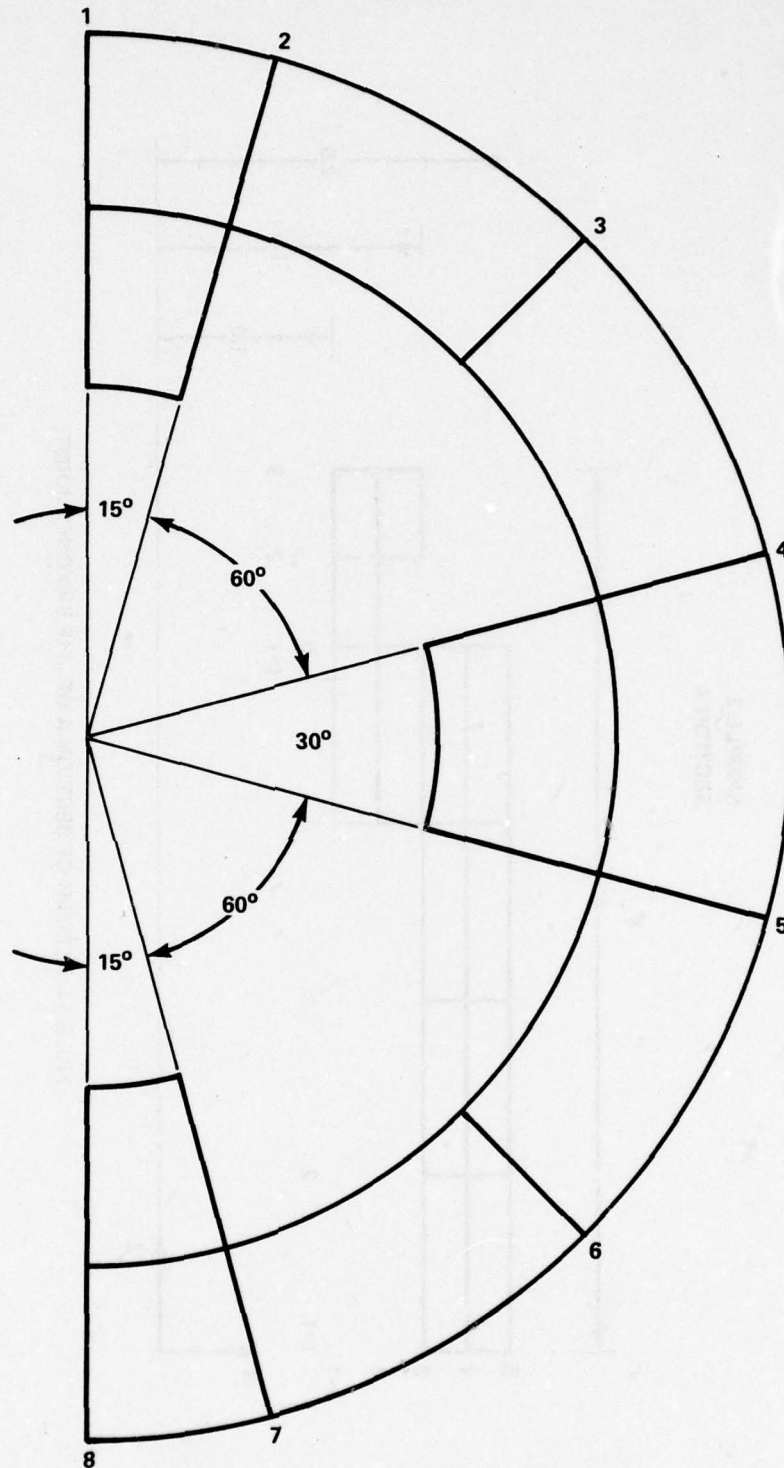

FIG. B-13 PLANNED FINITE ELEMENT MODEL AND CONFIGURATION OF A BAYONET JOINT.

SAMPLE 2  
SECTION A

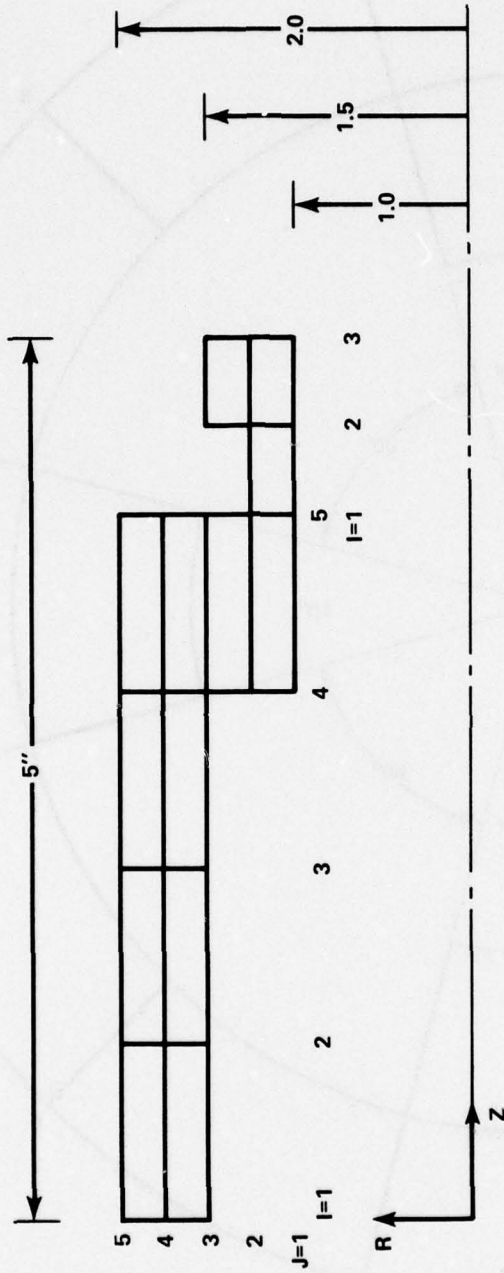

FIG. B-14 I-J MESH OF SECTION A OF THE BAYONET JOINT.

SAMPLE 2  
SECTION B

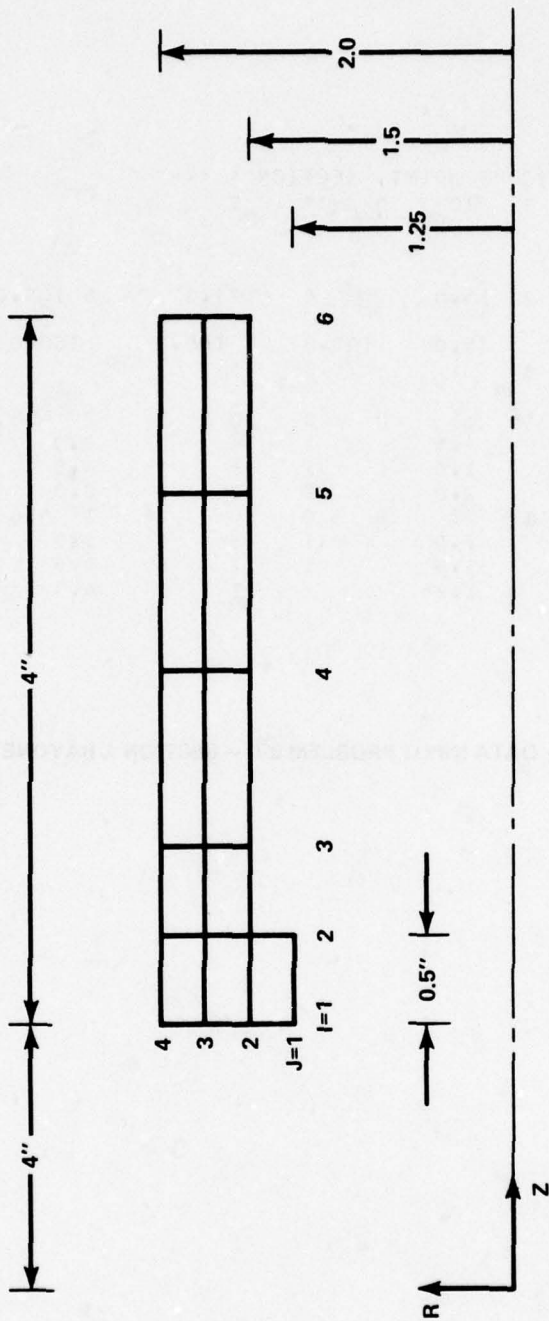

FIG. B-15 I-J MESH OF SECTION B OF THE BAYONET JOINT.

\*\*\* SAMPLE 2 - BAYONET JOINT, SECTION A \*\*\*

2	1	1	3	10	0	1	5					
1	1											
0.0		0.0										
5	1	30										
1	0.0		2	15.0		4	75.0	5	105.0	7	165.0	
8	180.0											
0.0		15.0		75.0		105.0	165.0	180.0				
1	5	3	5	1	5	3	5					
1	5											
6	1	5	1	5	0	0	0	1	2	456	0	
1	3	0.0		1.5		1	4	3	3.0		1.5	1
4	1	3.0		1.0		1	5	1	4.0		1.0	1
5	5	4.0		2.0		1	1	5	0.0		2.0	1
6	1	3	1	3	0	0	0	1	1	456	0	
1	1	4.0		1.0		1	3	1	5.0		1.0	1
3	3	5.0		1.5		1	2	3	4.5		1.5	1
2	2	4.5		1.25		1	1	2	4.0		1.25	1

FIG. B-16 DATA INPUT PROBLEM B-II - SECTION A BAYONET JOINT.

\*\*\* SAMPLE 2 - BAYONET JOINT, SECTION B

1	201	250	3	10	0	1	5					
1												
0.0												
5	1	30										
1	0.0		2	15.0		4	75.0	5	105.0		7	165.0
8	180.0											
0.0		15.0		75.0		105.0		165.0		180.0		
1	4	2	4	1	4	2	4					
1	4											
6	1	4	1	6	0	0	0	1	456	0		
1	1	4.0		1.25		1	2	1	4.5	1.25		1
2	2	4.5		1.5		1	6	2	8.0	1.5		1
6	4	8.0		2.0		1	1	4	4.0	2.0		1

FIG. B-17 DATA INPUT PROBLEM B-II - SECTION B BAYONET JOINT.

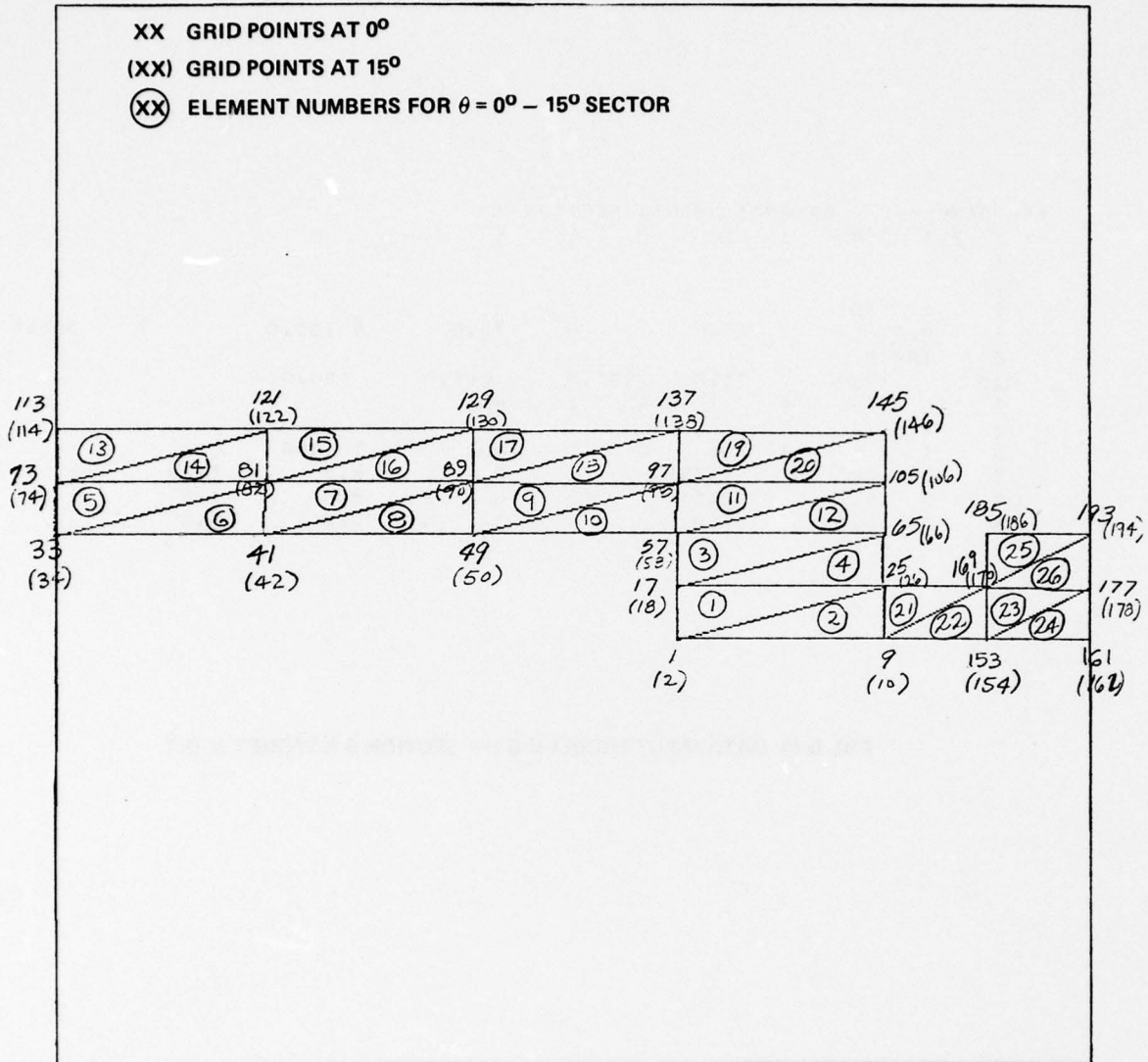

FIG. B-18 GRID POINT AND ELEMENT NUMBERS - 0° - 15° SECTOR

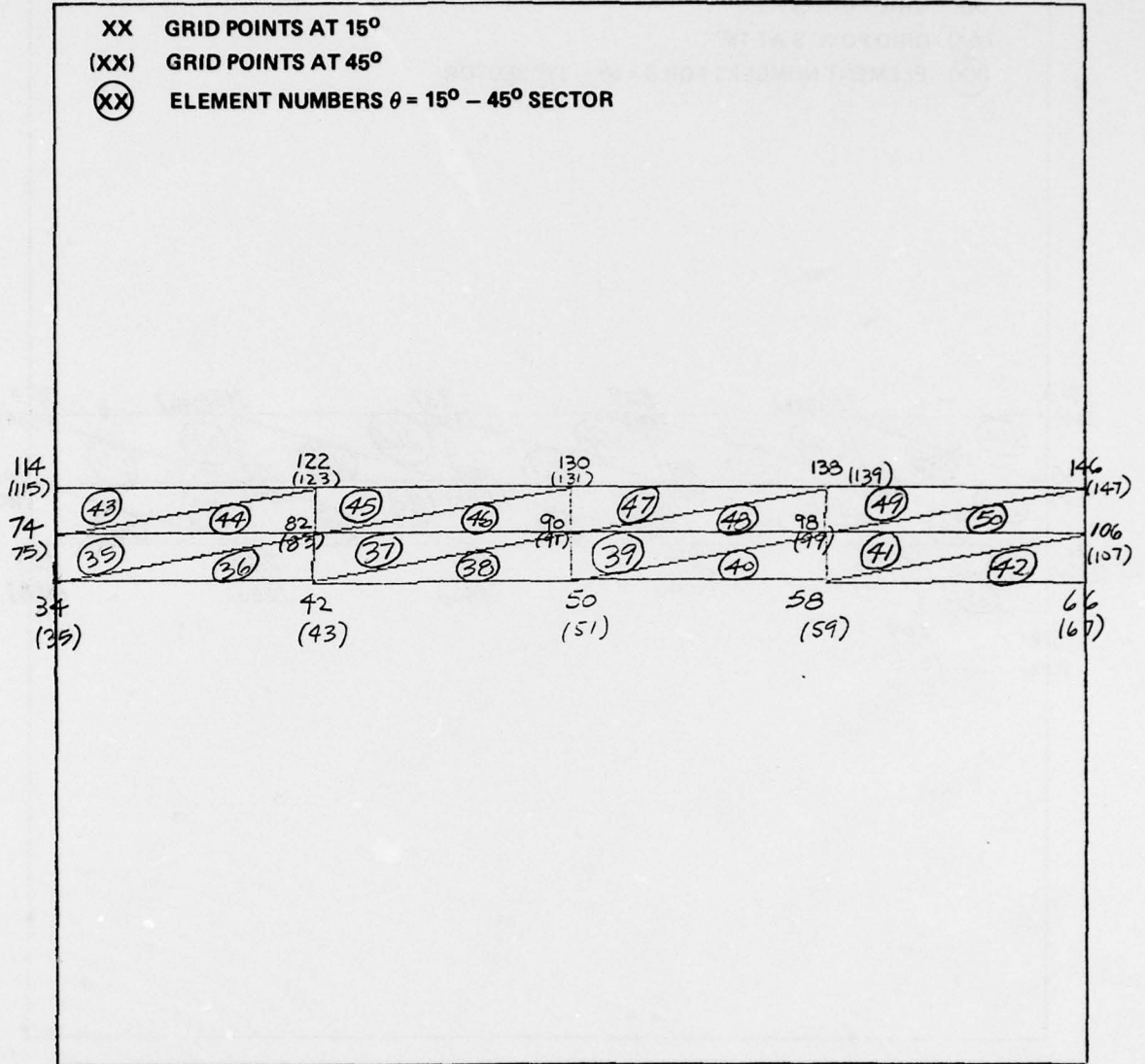

FIG. B-19 GRID POINT AND ELEMENT NUMBERS 15° TO 45° SECTOR

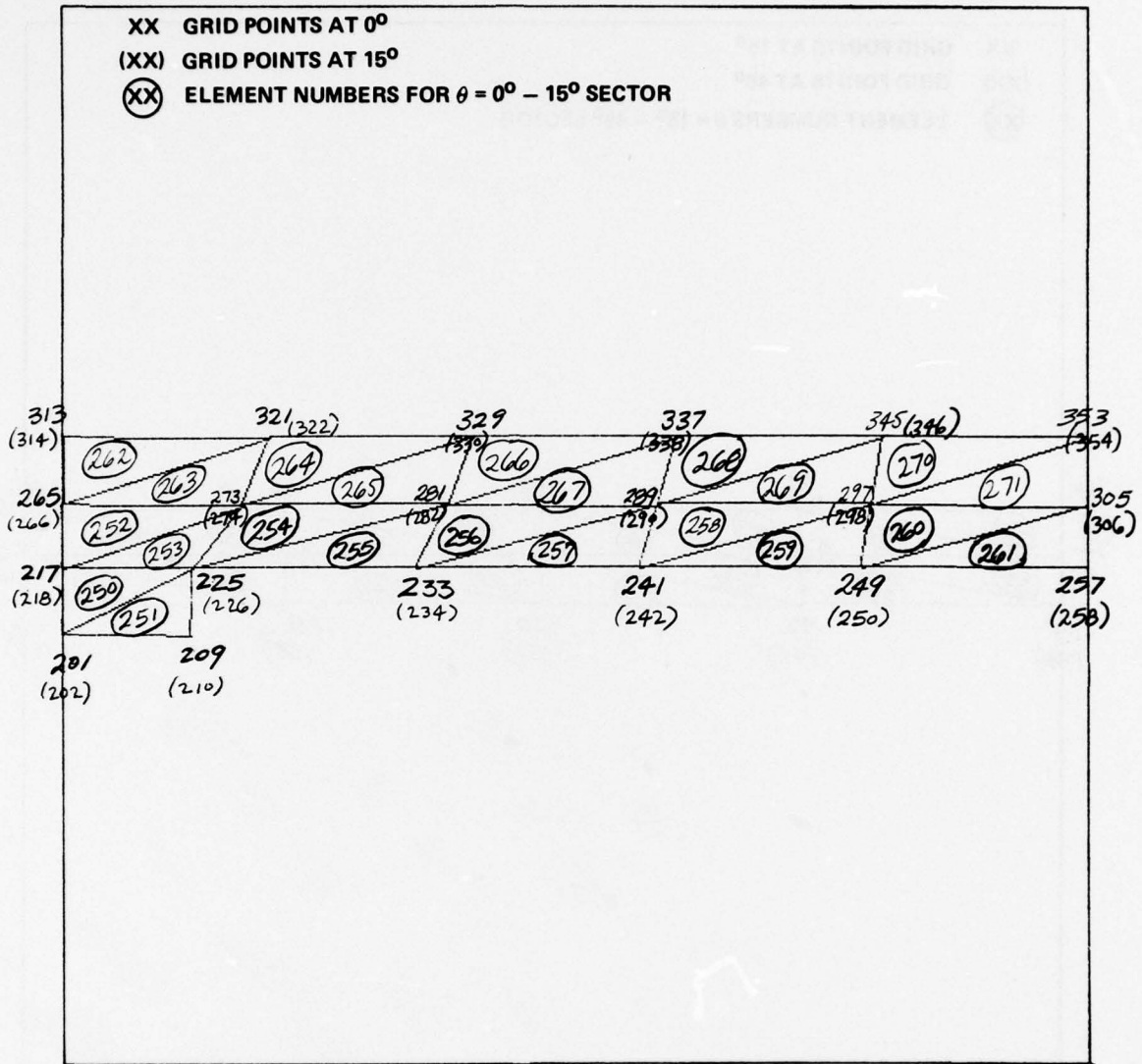

FIG. B-20 GRID POINT AND ELEMENT NUMBERS 0° TO 15° SECTOR

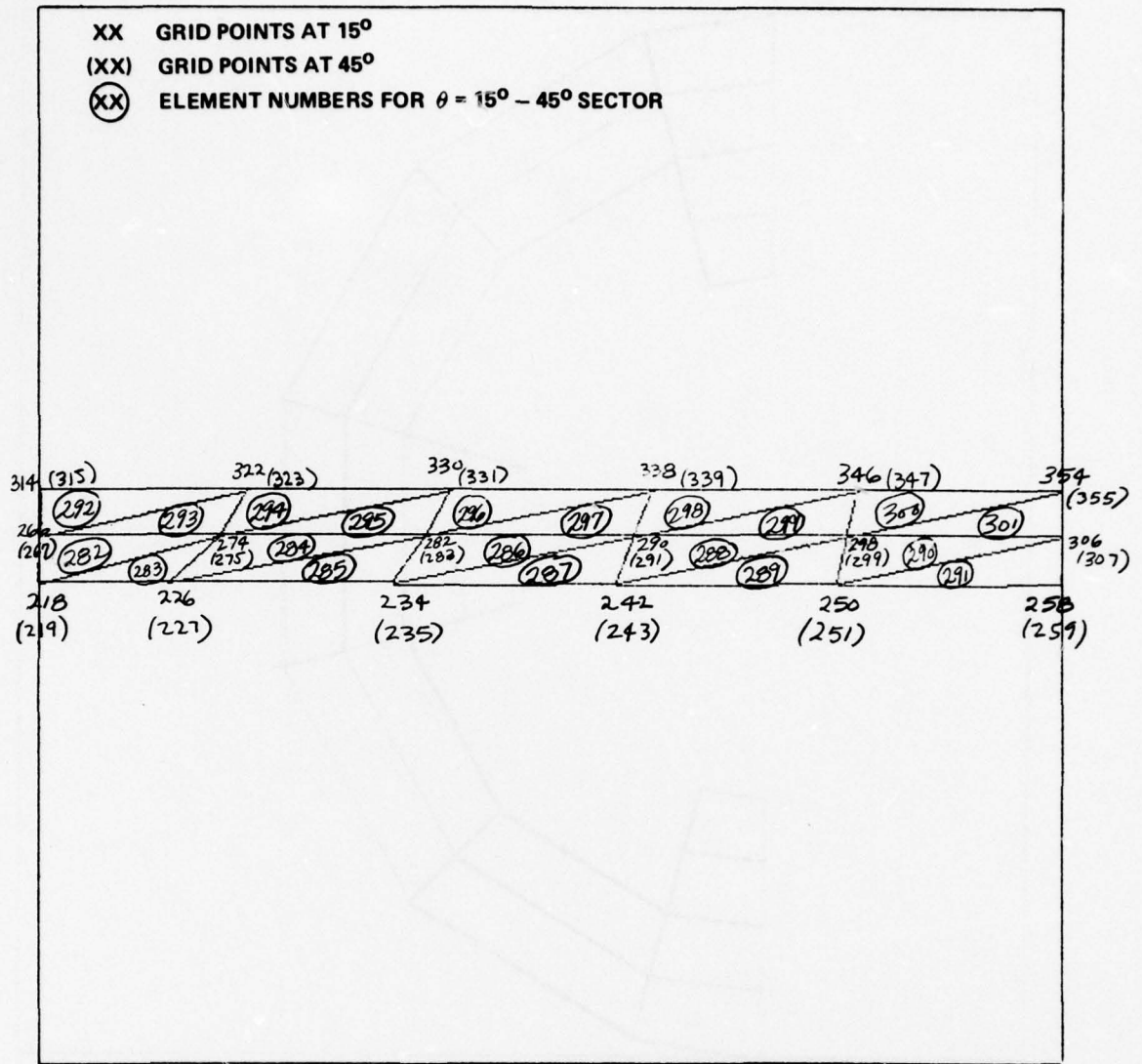

FIG. B-21 GRID POINT AND ELEMENT NUMBERS 15° TO 45° SECTOR

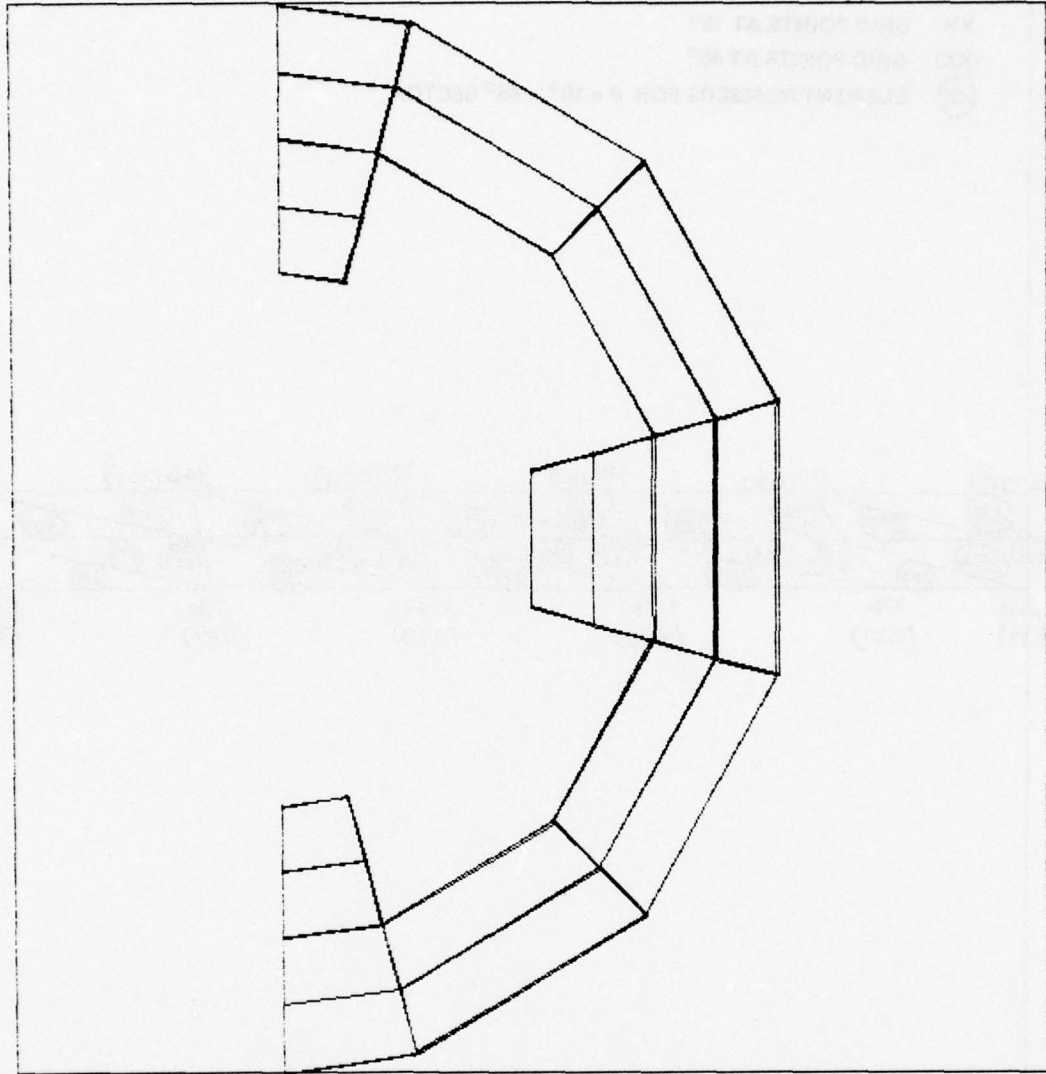

FIG. B-22 NASTRAN STRUCTURAL PLOT - END VIEW - SECTION A

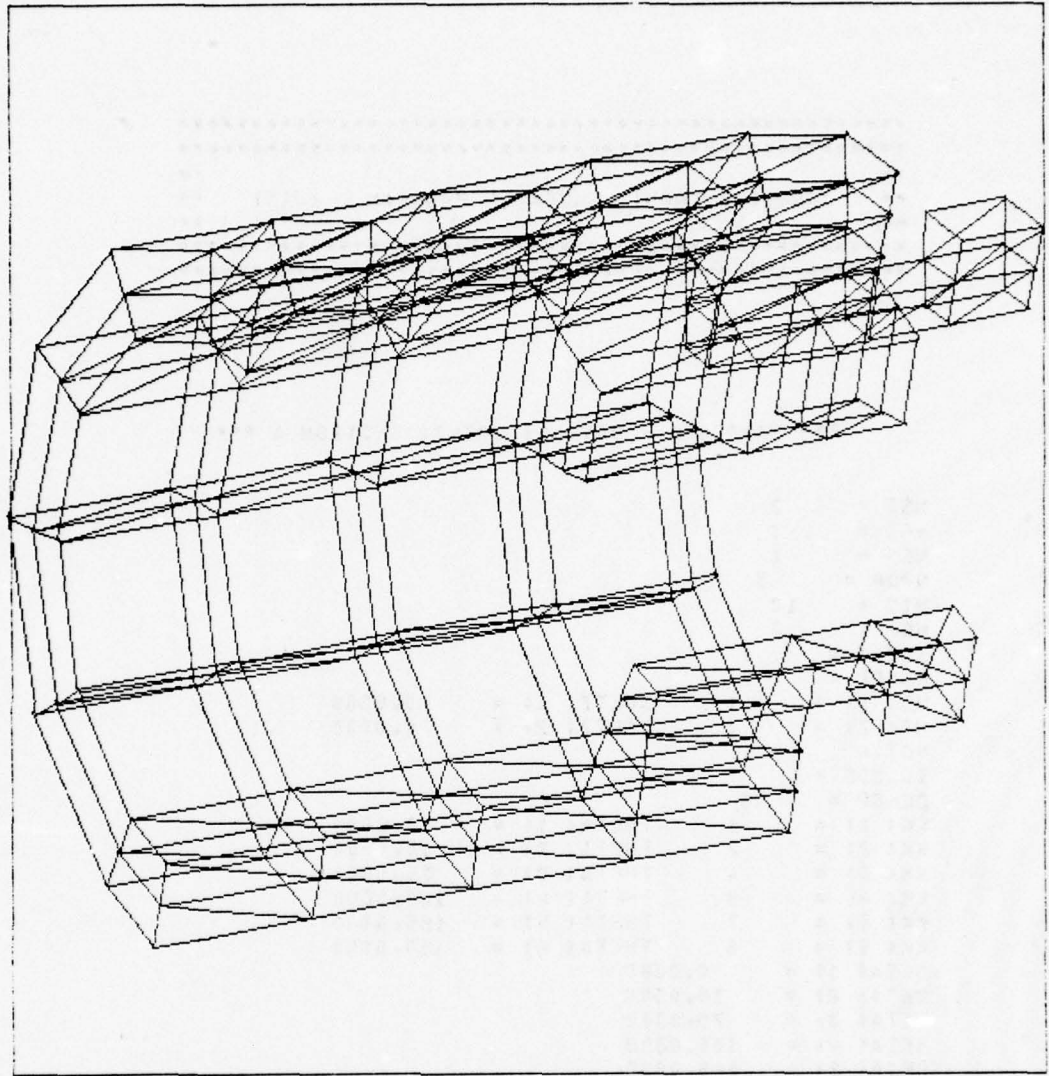

FIG. B-23 NASTRAN STRUCTURAL PLOT - ROTATED VIEW - SECTION A

LISTING OF PUNCHED NASTRAN BULK DATA CARDS  
 PROBLEM B-II VARIABLE CROSS SECTION SECTION A

```
*****
*****
**
**   JUNCTION INPUT GENERATOR PROGRAM   (JIG)  **
**
*****
*****
```

\*\*\* SAMPLE 2 - BAYONET JOINT, SECTION A \*\*\*

```
NST =      2
NGS =      1
NFS =      1
NPOP =     3
MID =     10
NGP =      0
IDELT =     1
NSECT =     5
NT( 1) =     1   DELTZ( 1) =     0.0000
NT( 2) =     1   DELTZ( 2) =     0.0000
NDT =      5
ICLOSE =     1
DELGP =    30
KK( 1) =     1   THETA( 1) =     0.0000
KK( 2) =     2   THETA( 2) =    15.0000
KK( 3) =     4   THETA( 3) =    75.0000
KK( 4) =     5   THETA( 4) =   105.0000
KK( 5) =     7   THETA( 5) =   165.0000
KK( 6) =     8   THETA( 6) =   180.0000
BETA( 1) =     0.0000
BETA( 2) =    15.0000
BETA( 3) =    75.0000
BETA( 4) =   105.0000
BETA( 5) =   165.0000
BETA( 6) =   180.0000
JB( 1) =     1   JE( 1) =     5
JB( 2) =     3   JE( 2) =     5
JB( 3) =     1   JF( 3) =     5
JB( 4) =     3   JF( 4) =     5
JB( 5) =     1   JE( 5) =     5
```

NSWC/WOL TR 77-85

I	J	Z(I,J)	X(I,J)	CODE(I,J)				
4	1	3.00000	1.00000	1				
5	1	4.00000	1.00000	1				
4	2	3.00000	1.25000	1				
5	2	4.00000	1.25000	1				
1	3	0.00000	1.50000	1				
2	3	1.00000	1.50000	1				
3	3	2.00000	1.50000	1				
4	3	3.00000	1.50000	1				
5	3	4.00000	1.50000	1				
1	4	0.00000	1.75000	1				
2	4	1.00000	1.75000	0				
3	4	2.00000	1.75001	0				
4	4	3.00002	1.75002	0				
5	4	4.00000	1.75000	1				
1	5	0.00000	2.00000	1				
2	5	1.00000	2.00000	1				
3	5	2.00000	2.00000	1				
4	5	3.00000	2.00000	1				
5	5	4.00000	2.00000	1				
GRID	1	1	1.0000	0.0000	3.0000	1	456	
GRID	2	1	1.0000	15.0000	3.0000	1	456	
GRID	4	1	1.0000	75.0000	3.0000	1	456	
GRID	5	1	1.0000	105.0000	3.0000	1	456	
GRID	7	1	1.0000	165.0000	3.0000	1	456	
GRID	8	1	1.0000	180.0000	3.0000	1	456	
GRID	9	1	1.0000	0.0000	4.0000	1	456	
GRID	10	1	1.0000	15.0000	4.0000	1	456	
GRID	12	1	1.0000	75.0000	4.0000	1	456	
GRID	13	1	1.0000	105.0000	4.0000	1	456	
GRID	15	1	1.0000	165.0000	4.0000	1	456	
GRID	16	1	1.0000	180.0000	4.0000	1	456	
GRID	17	1	1.2500	0.0000	3.0000	1	456	
GRID	18	1	1.2500	15.0000	3.0000	1	456	
GRID	20	1	1.2500	75.0000	3.0000	1	456	
GRID	21	1	1.2500	105.0000	3.0000	1	456	
GRID	23	1	1.2500	165.0000	3.0000	1	456	
GRID	24	1	1.2500	180.0000	3.0000	1	456	
GRID	25	1	1.2500	0.0000	4.0000	1	456	
GRID	26	1	1.2500	15.0000	4.0000	1	456	
GRID	28	1	1.2500	75.0000	4.0000	1	456	
GRID	29	1	1.2500	105.0000	4.0000	1	456	
GRID	31	1	1.2500	165.0000	4.0000	1	456	
GRID	32	1	1.2500	180.0000	4.0000	1	456	
CWEDGE	1	10	25	17	1	26	18	2
CWEDGE	91	10	28	20	4	29	21	5
CWEDGE	181	10	31	23	7	32	24	8
CWEDGE	2	10	1	9	25	2	10	26
CWEDGE	92	10	4	12	28	5	13	29
CWEDGE	182	10	7	15	31	8	16	32
GRID	33	1	1.5000	0.0000	0.0000	1	456	
GRID	34	1	1.5000	15.0000	0.0000	1	456	
GRID	35	1	1.5000	45.0000	0.0000	1	456	
GRID	36	1	1.5000	75.0000	0.0000	1	456	
GRID	37	1	1.5000	105.0000	0.0000	1	456	
GRID	38	1	1.5000	135.0000	0.0000	1	456	
GRID	39	1	1.5000	165.0000	0.0000	1	456	
GRID	40	1	1.5000	180.0000	0.0000	1	456	
GRID	41	1	1.5000	0.0000	1.0000	1	456	

NSWC/WOL TR 77-85

GRID	42	1	1.5000	15.0000	1.0000	1	456	
GRID	43	1	1.5000	45.0000	1.0000	1	456	
GRID	44	1	1.5000	75.0000	1.0000	1	456	
GRID	45	1	1.5000	105.0000	1.0000	1	456	
GRID	46	1	1.5000	135.0000	1.0000	1	456	
GRID	47	1	1.5000	165.0000	1.0000	1	456	
GRID	48	1	1.5000	180.0000	1.0000	1	456	
GRID	49	1	1.5000	0.0000	2.0000	1	456	
GRID	50	1	1.5000	15.0000	2.0000	1	456	
GRID	51	1	1.5000	45.0000	2.0000	1	456	
GRID	52	1	1.5000	75.0000	2.0000	1	456	
GRID	53	1	1.5000	105.0000	2.0000	1	456	
GRID	54	1	1.5000	135.0000	2.0000	1	456	
GRID	55	1	1.5000	165.0000	2.0000	1	456	
GRID	56	1	1.5000	180.0000	2.0000	1	456	
GRID	57	1	1.5000	0.0000	3.0000	1	456	
GRID	58	1	1.5000	15.0000	3.0000	1	456	
GRID	59	1	1.5000	45.0000	3.0000	1	456	
GRID	60	1	1.5000	75.0000	3.0000	1	456	
GRID	61	1	1.5000	105.0000	3.0000	1	456	
GRID	62	1	1.5000	135.0000	3.0000	1	456	
GRID	63	1	1.5000	165.0000	3.0000	1	456	
GRID	64	1	1.5000	180.0000	3.0000	1	456	
GRID	65	1	1.5000	0.0000	4.0000	1	456	
GRID	66	1	1.5000	15.0000	4.0000	1	456	
GRID	67	1	1.5000	45.0000	4.0000	1	456	
GRID	68	1	1.5000	75.0000	4.0000	1	456	
GRID	69	1	1.5000	105.0000	4.0000	1	456	
GRID	70	1	1.5000	135.0000	4.0000	1	456	
GRID	71	1	1.5000	165.0000	4.0000	1	456	
GRID	72	1	1.5000	180.0000	4.0000	1	456	
CWEDGE	3	10	65	57	17	66	58	18
CWEDGE	93	10	68	60	20	69	61	21
CWEDGE	183	10	71	63	23	72	64	24
CWEDGE	4	10	17	25	65	18	26	66
CWEDGE	94	10	20	28	68	21	29	69
CWEDGE	184	10	23	31	71	24	32	72
GRID	73	1	1.7500	0.0000	0.0000	1	456	
GRID	74	1	1.7500	15.0000	0.0000	1	456	
GRID	75	1	1.7500	45.0000	0.0000	1	456	
GRID	76	1	1.7500	75.0000	0.0000	1	456	
GRID	77	1	1.7500	105.0000	0.0000	1	456	
GRID	78	1	1.7500	135.0000	0.0000	1	456	
GRID	79	1	1.7500	165.0000	0.0000	1	456	
GRID	80	1	1.7500	180.0000	0.0000	1	456	
GRID	81	1	1.7500	0.0000	1.0000	1	456	
GRID	82	1	1.7500	15.0000	1.0000	1	456	
GRID	83	1	1.7500	45.0000	1.0000	1	456	
GRID	84	1	1.7500	75.0000	1.0000	1	456	
GRID	85	1	1.7500	105.0000	1.0000	1	456	
GRID	86	1	1.7500	135.0000	1.0000	1	456	
GRID	87	1	1.7500	165.0000	1.0000	1	456	
GRID	88	1	1.7500	180.0000	1.0000	1	456	
CWEDGE	5	10	81	73	33	82	74	34
CWEDGE	35	10	82	74	34	83	75	35
CWEDGE	65	10	83	75	35	84	76	36
CWEDGE	95	10	84	76	36	85	77	37
CWEDGE	125	10	85	77	37	86	78	38
CWEDGE	155	10	86	78	38	87	79	39
CWEDGE	185	10	87	79	39	88	80	40
CWEDGE	6	10	33	41	81	34	42	82
CWEDGE	36	10	34	42	82	35	43	83
CWEDGE	66	10	35	43	83	36	44	84
CWEDGE	96	10	36	44	84	37	45	85

NSWC/WOL TR 77-85

CWEDGE	126	10	37	45	85	38	46	86
CWEDGE	156	10	38	46	86	39	47	87
CWEDGE	186	10	39	47	87	40	48	88
GRID	89	1	1.7500	0.0000	2.0000	1	456	
GRID	90	1	1.7500	15.0000	2.0000	1	456	
GRID	91	1	1.7500	45.0000	2.0000	1	456	
GRID	92	1	1.7500	75.0000	2.0000	1	456	
GRID	93	1	1.7500	105.0000	2.0000	1	456	
GRID	94	1	1.7500	135.0000	2.0000	1	456	
GRID	95	1	1.7500	165.0000	2.0000	1	456	
GRID	96	1	1.7500	180.0000	2.0000	1	456	
CWEDGE	7	10	89	81	41	90	82	42
CWEDGE	37	10	90	82	42	91	83	43
CWEDGE	67	10	91	83	43	92	84	44
CWEDGE	97	10	92	84	44	93	85	45
CWEDGE	127	10	93	85	45	94	86	46
CWEDGE	157	10	94	86	46	95	87	47
CWEDGE	187	10	95	87	47	96	88	48
CWEDGE	8	10	41	49	89	42	50	90
CWEDGE	38	10	42	50	90	43	51	91
CWEDGE	68	10	43	51	91	44	52	92
CWEDGE	98	10	44	52	92	45	53	93
CWEDGE	128	10	45	53	93	46	54	94
CWEDGE	158	10	46	54	94	47	55	95
CWEDGE	188	10	47	55	95	48	56	96
GRID	97	1	1.7500	0.0000	3.0000	1	456	
GRID	98	1	1.7500	15.0000	3.0000	1	456	
GRID	99	1	1.7500	45.0000	3.0000	1	456	
GRID	100	1	1.7500	75.0000	3.0000	1	456	
GRID	101	1	1.7500	105.0000	3.0000	1	456	
GRID	102	1	1.7500	135.0000	3.0000	1	456	
GRID	103	1	1.7500	165.0000	3.0000	1	456	
GRID	104	1	1.7500	180.0000	3.0000	1	456	
CWEDGE	9	10	97	89	49	98	90	50
CWEDGE	39	10	98	90	50	99	91	51
CWEDGE	69	10	99	91	51	100	92	52
CWEDGE	99	10	100	92	52	101	93	53
CWEDGE	129	10	101	93	53	102	94	54
CWEDGE	159	10	102	94	54	103	95	55
CWEDGE	189	10	103	95	55	104	96	56
CWEDGE	10	10	49	57	97	50	58	98
CWEDGE	40	10	50	58	98	51	59	99
CWEDGE	70	10	51	59	99	52	60	100
CWEDGE	100	10	52	60	100	53	61	101
CWEDGE	130	10	53	61	101	54	62	102
CWEDGE	160	10	54	62	102	55	63	103
CWEDGE	190	10	55	63	103	56	64	104
GRID	105	1	1.7500	0.0000	4.0000	1	456	
GRID	106	1	1.7500	15.0000	4.0000	1	456	
GRID	107	1	1.7500	45.0000	4.0000	1	456	
GRID	108	1	1.7500	75.0000	4.0000	1	456	
GRID	109	1	1.7500	105.0000	4.0000	1	456	
GRID	110	1	1.7500	135.0000	4.0000	1	456	
GRID	111	1	1.7500	165.0000	4.0000	1	456	
GRID	112	1	1.7500	180.0000	4.0000	1	456	
CWEDGE	11	10	105	97	57	106	98	58
CWEDGE	41	10	106	98	58	107	99	59
CWEDGE	71	10	107	99	59	108	100	60
CWEDGE	101	10	108	100	60	109	101	61
CWEDGE	131	10	109	101	61	110	102	62
CWEDGE	161	10	110	102	62	111	103	63
CWEDGE	191	10	111	103	63	112	104	64
CWEDGE	12	10	57	65	105	58	66	106
CWEDGE	42	10	58	66	106	59	67	107

## NSWC/WOL TR 77-85

CWEDGE	72	10	59	67	107	60	68	108
CWEDGE	102	10	60	68	108	61	69	109
CWEDGE	132	10	61	69	109	62	70	110
CWEDGE	162	10	62	70	110	63	71	111
CWEDGE	192	10	63	71	111	64	72	112
GRID	113	1	2.0000	0.0000	0.0000	1	456	
GRID	114	1	2.0000	15.0000	0.0000	1	456	
GRID	115	1	2.0000	45.0000	0.0000	1	456	
GRID	116	1	2.0000	75.0000	0.0000	1	456	
GRID	117	1	2.0000	105.0000	0.0000	1	456	
GRID	118	1	2.0000	135.0000	0.0000	1	456	
GRID	119	1	2.0000	165.0000	0.0000	1	456	
GRID	120	1	2.0000	180.0000	0.0000	1	456	
GRID	121	1	2.0000	0.0000	1.0000	1	456	
GRID	122	1	2.0000	15.0000	1.0000	1	456	
GRID	123	1	2.0000	45.0000	1.0000	1	456	
GRID	124	1	2.0000	75.0000	1.0000	1	456	
GRID	125	1	2.0000	105.0000	1.0000	1	456	
GRID	126	1	2.0000	135.0000	1.0000	1	456	
GRID	127	1	2.0000	165.0000	1.0000	1	456	
GRID	128	1	2.0000	180.0000	1.0000	1	456	
CWEDGE	13	10	121	113	73	122	114	74
CWEDGE	43	10	122	114	74	123	115	75
CWEDGE	73	10	123	115	75	124	116	76
CWEDGE	103	10	124	116	76	125	117	77
CWEDGE	133	10	125	117	77	126	118	78
CWEDGE	163	10	126	118	78	127	119	79
CWEDGE	193	10	127	119	79	128	120	80
CWEDGE	14	10	73	81	121	74	82	122
CWEDGE	44	10	74	82	122	75	83	123
CWEDGE	74	10	75	83	123	76	84	124
CWEDGE	104	10	76	84	124	77	85	125
CWEDGE	134	10	77	85	125	78	86	126
CWEDGE	164	10	78	86	126	79	87	127
CWEDGE	194	10	79	87	127	80	88	128
GRID	129	1	2.0000	0.0000	2.0000	1	456	
GRID	130	1	2.0000	15.0000	2.0000	1	456	
GRID	131	1	2.0000	45.0000	2.0000	1	456	
GRID	132	1	2.0000	75.0000	2.0000	1	456	
GRID	133	1	2.0000	105.0000	2.0000	1	456	
GRID	134	1	2.0000	135.0000	2.0000	1	456	
GRID	135	1	2.0000	165.0000	2.0000	1	456	
GRID	136	1	2.0000	180.0000	2.0000	1	456	
CWEDGE	15	10	129	121	81	130	122	82
CWEDGE	45	10	130	122	82	131	123	83
CWEDGE	75	10	131	123	83	132	124	84
CWEDGE	105	10	132	124	84	133	125	85
CWEDGE	135	10	133	125	85	134	126	86
CWEDGE	165	10	134	126	86	135	127	87
CWEDGE	195	10	135	127	87	136	128	88
CWEDGE	16	10	81	89	129	82	90	130
CWEDGE	46	10	82	90	130	83	91	131
CWEDGE	76	10	83	91	131	84	92	132
CWEDGE	106	10	84	92	132	85	93	133
CWEDGE	136	10	85	93	133	86	94	134
CWEDGE	166	10	86	94	134	87	95	135
CWEDGE	196	10	87	95	135	88	96	136
GRID	137	1	2.0000	0.0000	3.0000	1	456	
GRID	138	1	2.0000	15.0000	3.0000	1	456	
GRID	139	1	2.0000	45.0000	3.0000	1	456	
GRID	140	1	2.0000	75.0000	3.0000	1	456	
GRID	141	1	2.0000	105.0000	3.0000	1	456	
GRID	142	1	2.0000	135.0000	3.0000	1	456	
GRID	143	1	2.0000	165.0000	3.0000	1	456	

NSWC/WOL TR 77-85

GRID	144	1	2.0000	180.0000	3.0000	1	456	
CWEDGE	17	10	137	129	89	138	130	90
CWEDGE	47	10	138	130	90	139	131	91
CWEDGE	77	10	139	131	91	140	132	92
CWEDGE	107	10	140	132	92	141	133	93
CWEDGE	137	10	141	133	93	142	134	94
CWEDGE	167	10	142	134	94	143	135	95
CWEDGE	197	10	143	135	95	144	136	96
CWEDGE	18	10	89	97	137	90	98	138
CWEDGE	48	10	90	98	138	91	99	139
CWEDGE	78	10	91	99	139	92	100	140
CWEDGE	108	10	92	100	140	93	101	141
CWEDGE	138	10	93	101	141	94	102	142
CWEDGE	168	10	94	102	142	95	103	143
CWEDGE	198	10	95	103	143	96	104	144
GRID	145	1	2.0000	0.0000	4.0000	1	456	
GRID	146	1	2.0000	15.0000	4.0000	1	456	
GRID	147	1	2.0000	45.0000	4.0000	1	456	
GRID	148	1	2.0000	75.0000	4.0000	1	456	
GRID	149	1	2.0000	105.0000	4.0000	1	456	
GRID	150	1	2.0000	135.0000	4.0000	1	456	
GRID	151	1	2.0000	165.0000	4.0000	1	456	
GRID	152	1	2.0000	180.0000	4.0000	1	456	
CWEDGE	19	10	145	137	97	146	138	98
CWEDGE	49	10	146	138	98	147	139	99
CWEDGE	79	10	147	139	99	148	140	100
CWEDGE	109	10	148	140	100	149	141	101
CWEDGE	139	10	149	141	101	150	142	102
CWEDGE	169	10	150	142	102	151	143	103
CWEDGE	199	10	151	143	103	152	144	104
CWEDGE	20	10	97	105	145	98	106	146
CWEDGE	50	10	98	106	146	99	107	147
CWEDGE	80	10	99	107	147	100	108	148
CWEDGE	110	10	100	108	148	101	109	149
CWEDGE	140	10	101	109	149	102	110	150
CWEDGE	170	10	102	110	150	103	111	151
CWEDGE	200	10	103	111	151	104	112	152

	I	J	Z(I,J)	X(I,J)	CODE(I,J)		
	1	1	4.00000	1.00000	1		
	2	1	4.50000	1.00000	1		
	3	1	5.00000	1.00000	1		
	1	2	4.00000	1.25000	1		
	2	2	4.50000	1.25000	1		
	3	2	5.00000	1.25000	1		
	2	3	4.50000	1.50000	1		
	3	3	5.00000	1.50000	1		
GRID	153	1	1.0000	0.0000	4.5000	1	456
GRID	154	1	1.0000	15.0000	4.5000	1	456
GRID	156	1	1.0000	75.0000	4.5000	1	456
GRID	157	1	1.0000	105.0000	4.5000	1	456
GRID	159	1	1.0000	165.0000	4.5000	1	456
GRID	160	1	1.0000	180.0000	4.5000	1	456
GRID	161	1	1.0000	0.0000	5.0000	1	456
GRID	162	1	1.0000	15.0000	5.0000	1	456
GRID	164	1	1.0000	75.0000	5.0000	1	456
GRID	165	1	1.0000	105.0000	5.0000	1	456
GRID	167	1	1.0000	165.0000	5.0000	1	456
GRID	168	1	1.0000	180.0000	5.0000	1	456
GRID	169	1	1.2500	0.0000	4.5000	1	456
GRID	170	1	1.2500	15.0000	4.5000	1	456

NSWC/WOL TR 77-85

GRID	172	1	1.2500	75.0000	4.5000	1	456	
GRID	173	1	1.2500	105.0000	4.5000	1	456	
GRID	175	1	1.2500	165.0000	4.5000	1	456	
GRID	176	1	1.2500	180.0000	4.5000	1	456	
CWEDGE	21	10	169	25	9	170	26	10
CWEDGE	111	10	172	28	12	173	29	13
CWEDGE	201	10	175	31	15	176	32	16
CWEDGE	22	10	9	153	169	10	154	170
CWEDGE	112	10	12	156	172	13	157	173
CWEDGE	202	10	15	159	175	16	160	176
GRID	177	1	1.2500	0.0000	5.0000	1	456	
GRID	178	1	1.2500	15.0000	5.0000	1	456	
GRID	180	1	1.2500	75.0000	5.0000	1	456	
GRID	181	1	1.2500	105.0000	5.0000	1	456	
GRID	183	1	1.2500	165.0000	5.0000	1	456	
GRID	184	1	1.2500	180.0000	5.0000	1	456	
CWEDGE	23	10	177	169	153	178	170	154
CWEDGE	113	10	180	172	156	181	173	157
CWEDGE	203	10	183	175	159	184	176	160
CWEDGE	24	10	153	161	177	154	162	178
CWEDGE	114	10	156	164	180	157	165	181
CWEDGE	204	10	159	167	183	160	168	184
GRID	185	1	1.5000	0.0000	4.5000	1	456	
GRID	186	1	1.5000	15.0000	4.5000	1	456	
GRID	188	1	1.5000	75.0000	4.5000	1	456	
GRID	189	1	1.5000	105.0000	4.5000	1	456	
GRID	191	1	1.5000	165.0000	4.5000	1	456	
GRID	192	1	1.5000	180.0000	4.5000	1	456	
GRID	193	1	1.5000	0.0000	5.0000	1	456	
GRID	194	1	1.5000	15.0000	5.0000	1	456	
GRID	196	1	1.5000	75.0000	5.0000	1	456	
GRID	197	1	1.5000	105.0000	5.0000	1	456	
GRID	199	1	1.5000	165.0000	5.0000	1	456	
GRID	200	1	1.5000	180.0000	5.0000	1	456	
CWEDGE	25	10	193	185	169	194	186	170
CWEDGE	115	10	196	188	172	197	189	173
CWEDGE	205	10	199	191	175	200	192	176
CWEDGE	26	10	169	177	193	170	178	194
CWEDGE	116	10	172	180	196	173	181	197
CWEDGE	206	10	175	183	199	176	184	200

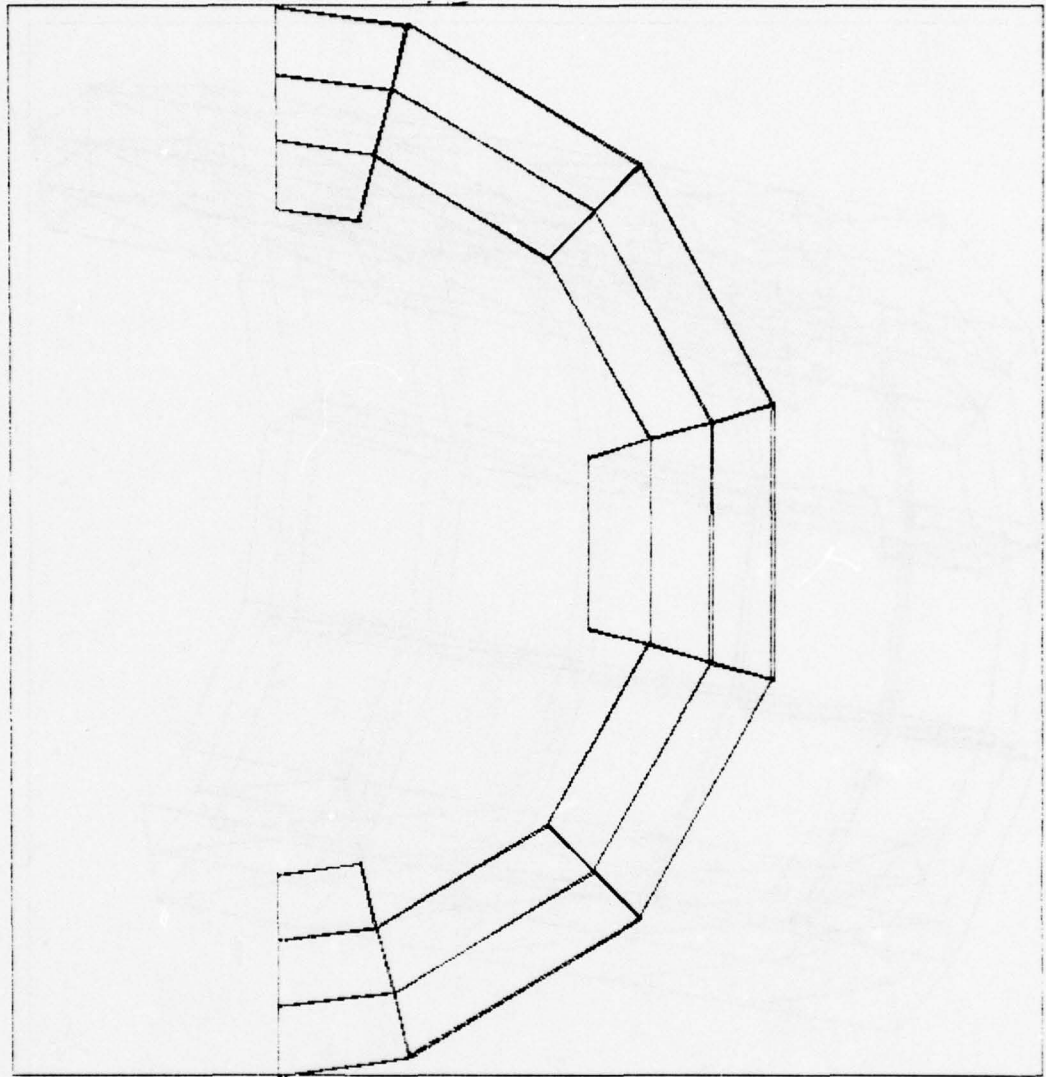

FIG. B-24 NASTRAN STRUCTURAL PLOT - END VIEW - SECTION B

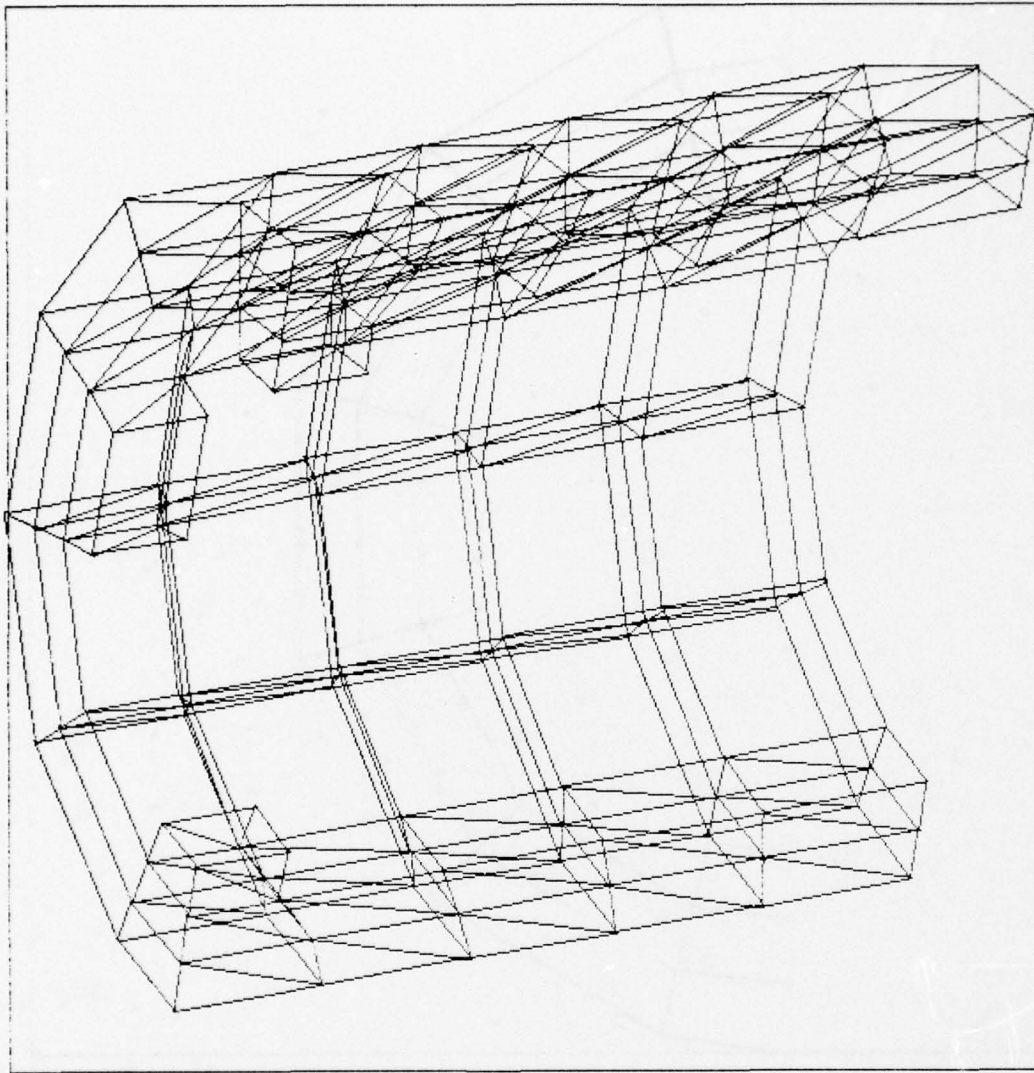

FIG. B-25 NASTRAN STRUCTURAL PLOT - ROTATED VIEW - SECTION B

LISTING OF PUNCHED NASTRAN BULK DATA CARDS  
 PROBLEM B-II VARIABLE CROSS SECTIONS SECTION B

```

*****
*****
**
**      JUNCTION INPUT GENERATOR PROGRAM      (JIG)
**
*****
*****
    
```

\*\*\* SAMPLE 2 - PAYONET JOINT, SECTION B

```

NST =      1
NGS =    201
NES =    250
NPOP =      3
MID =     10
NGP =      0
IDELT =     1
NSECT =     5
NT( 1) =     1      DELTZ( 1) =     0.0000
NDT =     5
ICLOSE =     1
DELGP =    30
KK( 1) =     1      THETA( 1) =     0.0000
KK( 2) =     2      THETA( 2) =    15.0000
KK( 3) =     4      THETA( 3) =    75.0000
KK( 4) =     5      THETA( 4) =   105.0000
KK( 5) =     7      THETA( 5) =   165.0000
KK( 6) =     8      THETA( 6) =   180.0000
BETA( 1) =     0.0000
BETA( 2) =    15.0000
BETA( 3) =    75.0000
BETA( 4) =   105.0000
BETA( 5) =   165.0000
BETA( 6) =   180.0000
JR( 1) =     1      JE( 1) =     4
JR( 2) =     2      JE( 2) =     4
JR( 3) =     1      JE( 3) =     4
JR( 4) =     2      JE( 4) =     4
JR( 5) =     1      JE( 5) =     4
    
```

NSWC/WOL TR 77-85

I	J	Z(I,J)	X(I,J)	CODE(I,J)					
1	1	4.00000	1.25000	1					
2	1	4.50000	1.25000	1					
1	2	4.00000	1.50000	1					
2	2	4.50000	1.50000	1					
3	2	5.37500	1.50000	1					
4	2	6.25000	1.50000	1					
5	2	7.12500	1.50000	1					
6	2	8.00000	1.50000	1					
1	3	4.00000	1.75000	1					
2	3	4.70028	1.75001	0					
3	3	5.50098	1.75000	0					
4	3	6.32855	1.74999	0					
5	3	7.16345	1.75002	0					
6	3	8.00000	1.75000	1					
1	4	4.00000	2.00000	1					
2	4	4.80000	2.00000	1					
3	4	5.60000	2.00000	1					
4	4	6.40000	2.00000	1					
5	4	7.20000	2.00000	1					
6	4	8.00000	2.00000	1					
GRID		201	1	1.2500	0.0000	4.0000	1	456	
GRID		202	1	1.2500	15.0000	4.0000	1	456	
GRID		204	1	1.2500	75.0000	4.0000	1	456	
GRID		205	1	1.2500	135.0000	4.0000	1	456	
GRID		207	1	1.2500	165.0000	4.0000	1	456	
GRID		208	1	1.2500	180.0000	4.0000	1	456	
GRID		209	1	1.2500	0.0000	4.5000	1	456	
GRID		210	1	1.2500	15.0000	4.5000	1	456	
GRID		212	1	1.2500	75.0000	4.5000	1	456	
GRID		213	1	1.2500	105.0000	4.5000	1	456	
GRID		215	1	1.2500	165.0000	4.5000	1	456	
GRID		216	1	1.2500	180.0000	4.5000	1	456	
GRID		217	1	1.5000	0.0000	4.0000	1	456	
GRID		218	1	1.5000	15.0000	4.0000	1	456	
GRID		219	1	1.5000	45.0000	4.0000	1	456	
GRID		220	1	1.5000	75.0000	4.0000	1	456	
GRID		221	1	1.5000	105.0000	4.0000	1	456	
GRID		222	1	1.5000	135.0000	4.0000	1	456	
GRID		223	1	1.5000	165.0000	4.0000	1	456	
GRID		224	1	1.5000	180.0000	4.0000	1	456	
GRID		225	1	1.5000	0.0000	4.5000	1	456	
GRID		226	1	1.5000	15.0000	4.5000	1	456	
GRID		227	1	1.5000	45.0000	4.5000	1	456	
GRID		228	1	1.5000	75.0000	4.5000	1	456	
GRID		229	1	1.5000	105.0000	4.5000	1	456	
GRID		230	1	1.5000	135.0000	4.5000	1	456	
GRID		231	1	1.5000	165.0000	4.5000	1	456	
GRID		232	1	1.5000	180.0000	4.5000	1	456	
QWEDGE		250	10	225	217	201	226	218	202
QWEDGE		340	10	228	220	204	229	221	205
QWEDGE		430	10	231	223	207	232	224	208
QWEDGE		251	10	201	209	225	202	210	226
QWEDGE		341	10	204	212	228	205	213	229
QWEDGE		431	10	207	215	231	208	216	232
GRID		233	1	1.5000	0.0000	5.3750	1	456	
GRID		234	1	1.5000	15.0000	5.3750	1	456	
GRID		235	1	1.5000	45.0000	5.3750	1	456	
GRID		236	1	1.5000	75.0000	5.3750	1	456	

NSWC/WOL TR 77-85

GRID	237	1	1.5000	105.0000	5.3750	1	456	
GRID	238	1	1.5000	135.0000	5.3750	1	456	
GRID	239	1	1.5000	165.0000	5.3750	1	456	
GRID	240	1	1.5000	180.0000	5.3750	1	456	
GRID	241	1	1.5000	0.0000	6.2500	1	456	
GRID	242	1	1.5000	15.0000	6.2500	1	456	
GRID	243	1	1.5000	45.0000	6.2500	1	456	
GRID	244	1	1.5000	75.0000	6.2500	1	456	
GRID	245	1	1.5000	105.0000	6.2500	1	456	
GRID	246	1	1.5000	135.0000	6.2500	1	456	
GRID	247	1	1.5000	165.0000	6.2500	1	456	
GRID	248	1	1.5000	180.0000	6.2500	1	456	
GRID	249	1	1.5000	0.0000	7.1250	1	456	
GRID	250	1	1.5000	15.0000	7.1250	1	456	
GRID	251	1	1.5000	45.0000	7.1250	1	456	
GRID	252	1	1.5000	75.0000	7.1250	1	456	
GRID	253	1	1.5000	105.0000	7.1250	1	456	
GRID	254	1	1.5000	135.0000	7.1250	1	456	
GRID	255	1	1.5000	165.0000	7.1250	1	456	
GRID	256	1	1.5000	180.0000	7.1250	1	456	
GRID	257	1	1.5000	0.0000	8.0000	1	456	
GRID	258	1	1.5000	15.0000	8.0000	1	456	
GRID	259	1	1.5000	45.0000	8.0000	1	456	
GRID	260	1	1.5000	75.0000	8.0000	1	456	
GRID	261	1	1.5000	105.0000	8.0000	1	456	
GRID	262	1	1.5000	135.0000	8.0000	1	456	
GRID	263	1	1.5000	165.0000	8.0000	1	456	
GRID	264	1	1.5000	180.0000	8.0000	1	456	
GRID	265	1	1.7500	0.0000	4.0000	1	456	
GRID	266	1	1.7500	15.0000	4.0000	1	456	
GRID	267	1	1.7500	45.0000	4.0000	1	456	
GRID	268	1	1.7500	75.0000	4.0000	1	456	
GRID	269	1	1.7500	105.0000	4.0000	1	456	
GRID	270	1	1.7500	135.0000	4.0000	1	456	
GRID	271	1	1.7500	165.0000	4.0000	1	456	
GRID	272	1	1.7500	180.0000	4.0000	1	456	
GRID	273	1	1.7500	0.0000	4.7003	1	456	
GRID	274	1	1.7500	15.0000	4.7003	1	456	
GRID	275	1	1.7500	45.0000	4.7003	1	456	
GRID	276	1	1.7500	75.0000	4.7003	1	456	
GRID	277	1	1.7500	105.0000	4.7003	1	456	
GRID	278	1	1.7500	135.0000	4.7003	1	456	
GRID	279	1	1.7500	165.0000	4.7003	1	456	
GRID	280	1	1.7500	180.0000	4.7003	1	456	
CWEDGE	252	10	273	265	217	274	266	218
CWEDGE	282	10	274	266	218	275	267	219
CWEDGE	312	10	275	267	219	276	268	220
CWEDGE	342	10	276	268	220	277	269	221
CWEDGE	372	10	277	269	221	278	270	222
CWEDGE	402	10	278	270	222	279	271	223
CWEDGE	432	10	279	271	223	280	272	224
CWEDGE	253	10	217	225	273	218	226	274
CWEDGE	283	10	218	226	274	219	227	275
CWEDGE	313	10	219	227	275	220	228	276
CWEDGE	343	10	220	228	276	221	229	277
CWEDGE	373	10	221	229	277	222	230	278
CWEDGE	403	10	222	230	278	223	231	279
CWEDGE	433	10	223	231	279	224	232	280
GRID	281	1	1.7500	0.0000	5.5010	1	456	
GRID	282	1	1.7500	15.0000	5.5010	1	456	
GRID	283	1	1.7500	45.0000	5.5010	1	456	
GRID	284	1	1.7500	75.0000	5.5010	1	456	
GRID	285	1	1.7500	105.0000	5.5010	1	456	
GRID	286	1	1.7500	135.0000	5.5010	1	456	

NSWC/WOL TR 77-85

GRID	287	1	1.7500	165.0000	5.5010	1	456	
GRID	288	1	1.7500	180.0000	5.5010	1	456	
CWEDGE	254	10	281	273	225	282	274	226
CWEDGE	284	10	282	274	226	283	275	227
CWEDGE	314	10	283	275	227	284	276	228
CWEDGE	344	10	284	276	228	285	277	229
CWEDGE	374	10	285	277	229	286	278	230
CWEDGE	404	10	286	278	230	287	279	231
CWEDGE	434	10	287	279	231	288	280	232
CWEDGE	255	10	225	233	281	226	234	282
CWEDGE	285	10	226	234	282	227	235	283
CWEDGE	315	10	227	235	283	228	236	284
CWEDGE	345	10	228	236	284	229	237	285
CWEDGE	375	10	229	237	285	230	238	286
CWEDGE	405	10	230	238	286	231	239	287
CWEDGE	435	10	231	239	287	232	240	288
GRID	289	1	1.7500	0.0000	6.3286	1	456	
GRID	290	1	1.7500	15.0000	6.3286	1	456	
GRID	291	1	1.7500	45.0000	6.3286	1	456	
GRID	292	1	1.7500	75.0000	6.3286	1	456	
GRID	293	1	1.7500	105.0000	6.3286	1	456	
GRID	294	1	1.7500	135.0000	6.3286	1	456	
GRID	295	1	1.7500	165.0000	6.3286	1	456	
GRID	296	1	1.7500	180.0000	6.3286	1	456	
CWEDGE	256	10	289	281	233	290	282	234
CWEDGE	286	10	290	282	234	291	283	235
CWEDGE	316	10	291	283	235	292	284	236
CWEDGE	346	10	292	284	236	293	285	237
CWEDGE	376	10	293	285	237	294	286	238
CWEDGE	406	10	294	286	238	295	287	239
CWEDGE	436	10	295	287	239	296	288	240
CWEDGE	257	10	233	241	289	234	242	290
CWEDGE	287	10	234	242	290	235	243	291
CWEDGE	317	10	235	243	291	236	244	292
CWEDGE	347	10	236	244	292	237	245	293
CWEDGE	377	10	237	245	293	238	246	294
CWEDGE	407	10	238	246	294	239	247	295
CWEDGE	437	10	239	247	295	240	248	296
GRID	297	1	1.7500	0.0000	7.1635	1	456	
GRID	298	1	1.7500	15.0000	7.1635	1	456	
GRID	299	1	1.7500	45.0000	7.1635	1	456	
GRID	300	1	1.7500	75.0000	7.1635	1	456	
GRID	301	1	1.7500	105.0000	7.1635	1	456	
GRID	302	1	1.7500	135.0000	7.1635	1	456	
GRID	303	1	1.7500	165.0000	7.1635	1	456	
GRID	304	1	1.7500	180.0000	7.1635	1	456	
CWEDGE	258	10	297	289	241	298	290	242
CWEDGE	288	10	298	290	242	299	291	243
CWEDGE	318	10	299	291	243	300	292	244
CWEDGE	348	10	300	292	244	301	293	245
CWEDGE	378	10	301	293	245	302	294	246
CWEDGE	408	10	302	294	246	303	295	247
CWEDGE	438	10	303	295	247	304	296	248
CWEDGE	259	10	241	249	297	242	250	298
CWEDGE	289	10	242	250	298	243	251	299
CWEDGE	319	10	243	251	299	244	252	300
CWEDGE	349	10	244	252	300	245	253	301
CWEDGE	379	10	245	253	301	246	254	302
CWEDGE	409	10	246	254	302	247	255	303
CWEDGE	439	10	247	255	303	248	256	304
GRID	305	1	1.7500	0.0000	8.0000	1	456	
GRID	306	1	1.7500	15.0000	8.0000	1	456	
GRID	307	1	1.7500	45.0000	8.0000	1	456	
GRID	308	1	1.7500	75.0000	8.0000	1	456	

NSWC/WOL TR 77-85

GRID	309	1	1.7500	105.0000	8.0000	1	456	
GRID	310	1	1.7500	135.0000	8.0000	1	456	
GRID	311	1	1.7500	165.0000	8.0000	1	456	
GRID	312	1	1.7500	180.0000	8.0000	1	456	
CWEDGE	260	10	305	297	249	306	298	250
CWEDGE	290	10	306	298	250	307	299	251
CWEDGE	320	10	307	299	251	308	300	252
CWEDGE	350	10	308	300	252	309	301	253
CWEDGE	380	10	309	301	253	310	302	254
CWEDGE	410	10	310	302	254	311	303	255
CWEDGE	440	10	311	303	255	312	304	256
CWEDGE	261	10	249	257	305	250	258	306
CWEDGE	291	10	250	258	306	251	259	307
CWEDGE	321	10	251	259	307	252	260	308
CWEDGE	351	10	252	260	308	253	261	309
CWEDGE	381	10	253	261	309	254	262	310
CWEDGE	411	10	254	262	310	255	263	311
CWEDGE	441	10	255	263	311	256	264	312
GRID	313	1	2.0000	0.0000	4.0000	1	456	
GRID	314	1	2.0000	15.0000	4.0000	1	456	
GRID	315	1	2.0000	45.0000	4.0000	1	456	
GRID	316	1	2.0000	75.0000	4.0000	1	456	
GRID	317	1	2.0000	105.0000	4.0000	1	456	
GRID	318	1	2.0000	135.0000	4.0000	1	456	
GRID	319	1	2.0000	165.0000	4.0000	1	456	
GRID	320	1	2.0000	180.0000	4.0000	1	456	
GRID	321	1	2.0000	0.0000	4.8000	1	456	
GRID	322	1	2.0000	15.0000	4.8000	1	456	
GRID	323	1	2.0000	45.0000	4.8000	1	456	
GRID	324	1	2.0000	75.0000	4.8000	1	456	
GRID	325	1	2.0000	105.0000	4.8000	1	456	
GRID	326	1	2.0000	135.0000	4.8000	1	456	
GRID	327	1	2.0000	165.0000	4.8000	1	456	
GRID	328	1	2.0000	180.0000	4.8000	1	456	
CWEDGE	262	10	321	313	265	322	314	266
CWEDGE	292	10	322	314	266	323	315	267
CWEDGE	322	10	323	315	267	324	316	268
CWEDGE	352	10	324	316	268	325	317	269
CWEDGE	382	10	325	317	269	326	318	270
CWEDGE	412	10	326	318	270	327	319	271
CWEDGE	442	10	327	319	271	328	320	272
CWEDGE	263	10	265	273	321	266	274	322
CWEDGE	293	10	266	274	322	267	275	323
CWEDGE	323	10	267	275	323	268	276	324
CWEDGE	353	10	268	276	324	269	277	325
CWEDGE	383	10	269	277	325	270	278	326
CWEDGE	413	10	270	278	326	271	279	327
CWEDGE	443	10	271	279	327	272	280	328
GRID	329	1	2.0000	0.0000	5.6000	1	456	
GRID	330	1	2.0000	15.0000	5.6000	1	456	
GRID	331	1	2.0000	45.0000	5.6000	1	456	
GRID	332	1	2.0000	75.0000	5.6000	1	456	
GRID	333	1	2.0000	105.0000	5.6000	1	456	
GRID	334	1	2.0000	135.0000	5.6000	1	456	
GRID	335	1	2.0000	165.0000	5.6000	1	456	
GRID	336	1	2.0000	180.0000	5.6000	1	456	
CWEDGE	264	10	329	321	273	330	322	274
CWEDGE	294	10	330	322	274	331	323	275
CWEDGE	324	10	331	323	275	332	324	276
CWEDGE	354	10	332	324	276	333	325	277
CWEDGE	384	10	333	325	277	334	326	278
CWEDGE	414	10	334	326	278	335	327	279
CWEDGE	444	10	335	327	279	336	328	280
CWEDGE	265	10	273	281	329	274	282	330

## NSWC/WOL TR 77-85

CWEDGE	295	10	274	282	330	275	283	331
CWEDGE	325	10	275	283	331	276	284	332
CWEDGE	355	10	276	284	332	277	285	333
CWEDGE	385	10	277	285	333	278	286	334
CWEDGE	415	10	278	286	334	279	287	335
CWEDGE	445	10	279	287	335	280	288	336
GRID	337	1	2.0000	0.0000	6.4000	1	456	
GRID	338	1	2.0000	15.0000	6.4000	1	456	
GRID	339	1	2.0000	45.0000	6.4000	1	456	
GRID	340	1	2.0000	75.0000	6.4000	1	456	
GRID	341	1	2.0000	105.0000	6.4000	1	456	
GRID	342	1	2.0000	135.0000	6.4000	1	456	
GRID	343	1	2.0000	165.0000	6.4000	1	456	
GRID	344	1	2.0000	180.0000	6.4000	1	456	
CWEDGE	266	10	337	329	281	338	330	282
CWEDGE	296	10	338	330	282	339	331	283
CWEDGE	326	10	339	331	283	340	332	284
CWEDGE	356	10	340	332	284	341	333	285
CWEDGE	386	10	341	333	285	342	334	286
CWEDGE	416	10	342	334	286	343	335	287
CWEDGE	446	10	343	335	287	344	336	288
CWEDGE	267	10	281	289	337	282	290	338
CWEDGE	297	10	282	290	338	283	291	339
CWEDGE	327	10	283	291	339	284	292	340
CWEDGE	357	10	284	292	340	285	293	341
CWEDGE	387	10	285	293	341	286	294	342
CWEDGE	417	10	286	294	342	287	295	343
CWEDGE	447	10	287	295	343	288	296	344
GRID	345	1	2.0000	0.0000	7.2000	1	456	
GRID	346	1	2.0000	15.0000	7.2000	1	456	
GRID	347	1	2.0000	45.0000	7.2000	1	456	
GRID	348	1	2.0000	75.0000	7.2000	1	456	
GRID	349	1	2.0000	105.0000	7.2000	1	456	
GRID	350	1	2.0000	135.0000	7.2000	1	456	
GRID	351	1	2.0000	165.0000	7.2000	1	456	
GRID	352	1	2.0000	180.0000	7.2000	1	456	
CWEDGE	268	10	345	337	289	346	338	290
CWEDGE	298	10	346	338	290	347	339	291
CWEDGE	328	10	347	339	291	348	340	292
CWEDGE	358	10	348	340	292	349	341	293
CWEDGE	388	10	349	341	293	350	342	294
CWEDGE	418	10	350	342	294	351	343	295
CWEDGE	448	10	351	343	295	352	344	296
CWEDGE	269	10	289	297	345	290	298	346
CWEDGE	299	10	290	298	346	291	299	347
CWEDGE	329	10	291	299	347	292	300	348
CWEDGE	359	10	292	300	348	293	301	349
CWEDGE	389	10	293	301	349	294	302	350
CWEDGE	419	10	294	302	350	295	303	351
CWEDGE	449	10	295	303	351	296	304	352
GRID	353	1	2.0000	0.0000	8.0000	1	456	
GRID	354	1	2.0000	15.0000	8.0000	1	456	
GRID	355	1	2.0000	45.0000	8.0000	1	456	
GRID	356	1	2.0000	75.0000	8.0000	1	456	
GRID	357	1	2.0000	105.0000	8.0000	1	456	
GRID	358	1	2.0000	135.0000	8.0000	1	456	
GRID	359	1	2.0000	165.0000	8.0000	1	456	
GRID	360	1	2.0000	180.0000	8.0000	1	456	
CWEDGE	270	10	353	345	297	354	346	298
CWEDGE	300	10	354	346	298	355	347	299
CWEDGE	330	10	355	347	299	356	348	300
CWEDGE	360	10	356	348	300	357	349	301
CWEDGE	390	10	357	349	301	358	350	302
CWEDGE	420	10	358	350	302	359	351	303

## NSWC/WOL TR 77-85

CWEDGE	450	10	359	351	303	360	352	304
CWEDGE	271	10	297	305	353	298	306	354
CWEDGE	301	10	298	306	354	299	307	355
CWEDGE	331	10	299	307	355	300	308	356
CWEDGE	361	10	300	308	356	301	309	357
CWEDGE	391	10	301	309	357	302	310	358
CWEDGE	421	10	302	310	358	303	311	359
CWEDGE	451	10	303	311	359	304	312	360

## PROBLEM B-III

## REPEATED SECTION

The following problem demonstrates the JIG repeated section option. Figure B-26 shows the planned finite element model and configuration of one half of a threaded joint. This model consists of two sections. The first represents the skin, the second the threads. Since the threads of this model have a consistent geometry and spacing only the first need be input. A complete listing of the data input is shown in Figure B-27. Figures B-28 and B-29 show the grid point and element numbers as generated by JIG. Figure B-30 gives a NASTRAN structural plot and is followed by a listing of the JIG punched output.

SAMPLE 3

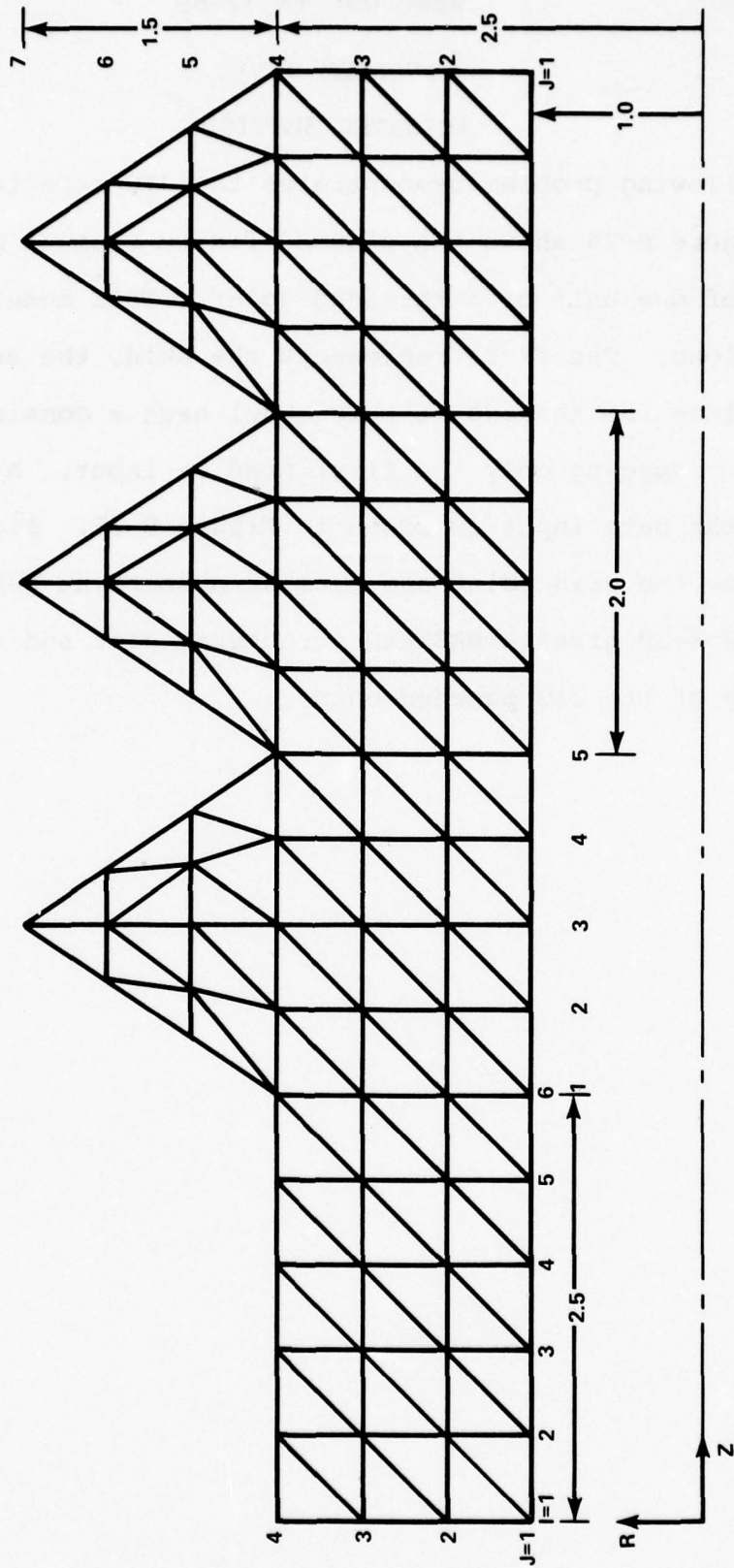

FIG. B-26 PLANNED FINITE ELEMENT MODEL AND CONFIGURATION OF ONE HALF OF A THREADED JOINT.

```

*** SAMPLE 3 - REPEATED SECTION TYPE ***
 2  1  1  1  5  0  0  1
 1  3
0.0  2.0
 4  1  4  1  6  0  0  0  1  4  4.0  0
 1  1  0.0  1.0  1  6  1  2.5  1.0  1
 6  4  2.5  2.5  1  1  4  0.0  2.5  1
 6  1  6  1  5  0  1  1  1  4  4.0  0
 7  3.5  4.0
 1  1  2.5  1.0  1  5  1  4.5  1.0  1
 5  4  4.5  2.5  1  5  6  3.8333  3.5  1
 1  6  3.1667  3.5  1  1  4  2.5  2.5  1
 0
 6  1

```

FIG. B-27 DATA INPUT PROBLEM B-III REPEATED SECTION

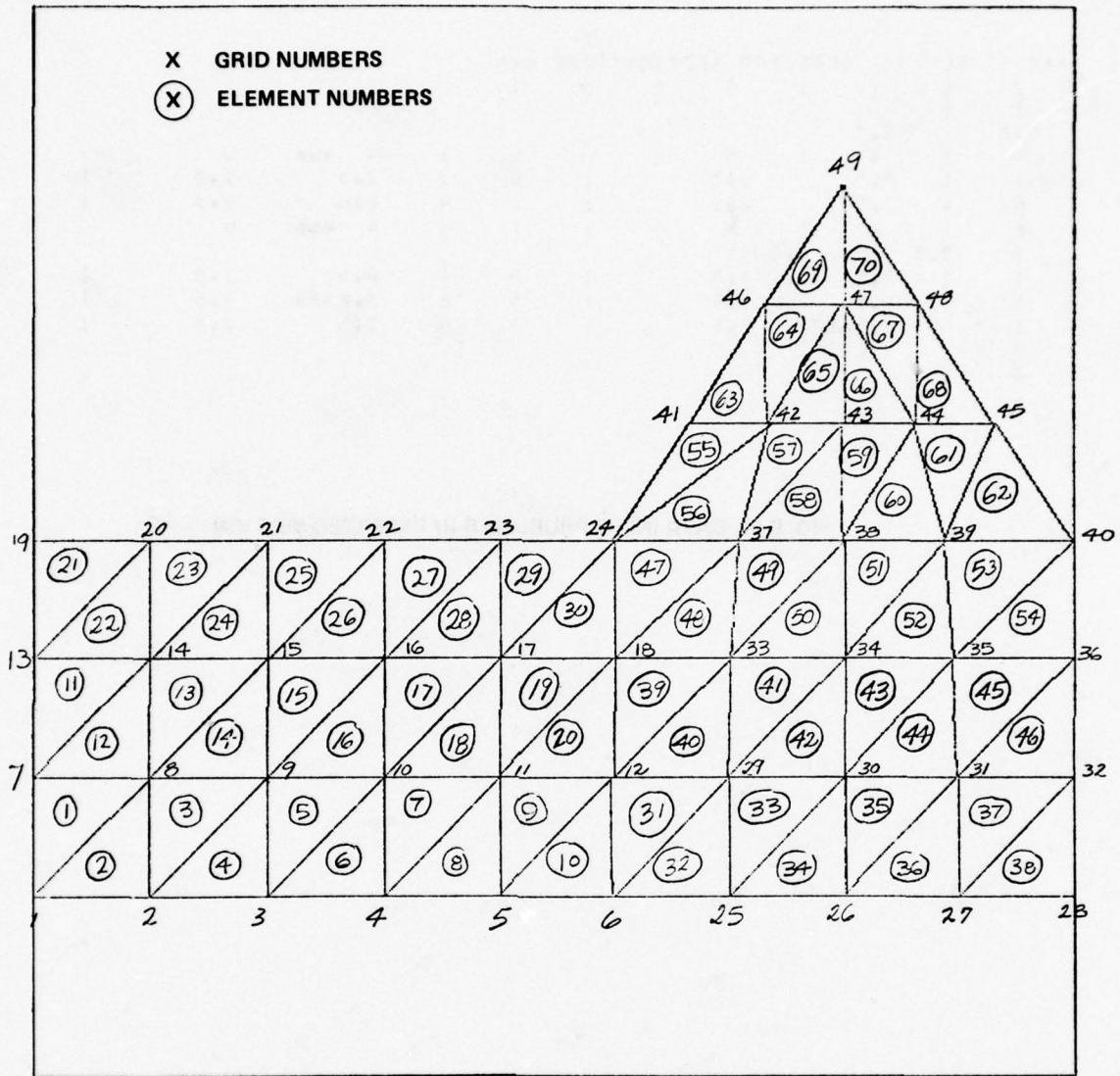

FIG. B-28 GRID POINT AND ELEMENT NUMBERS

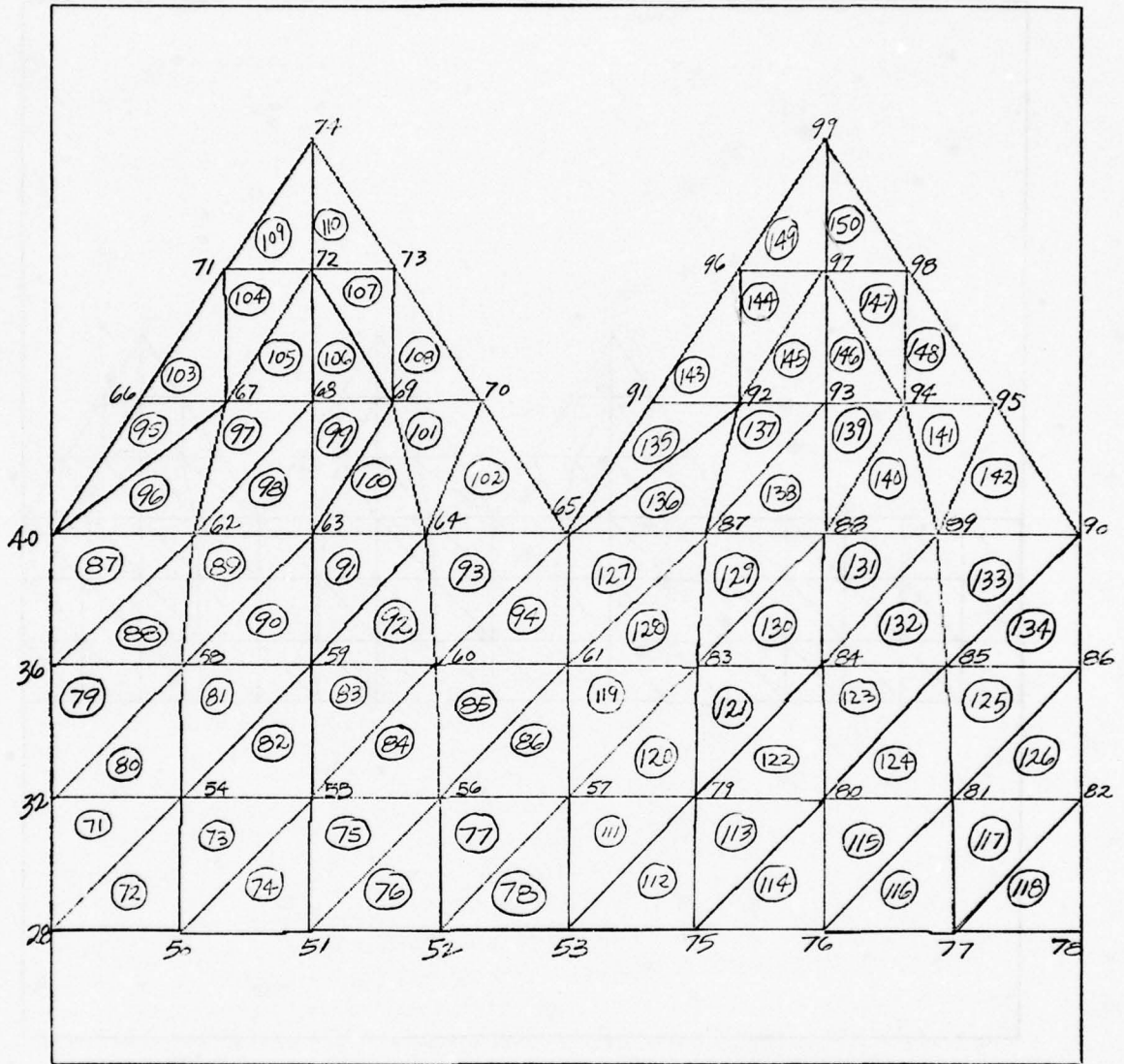

FIG. B-29 GRID POINT AND ELEMENT NUMBERS

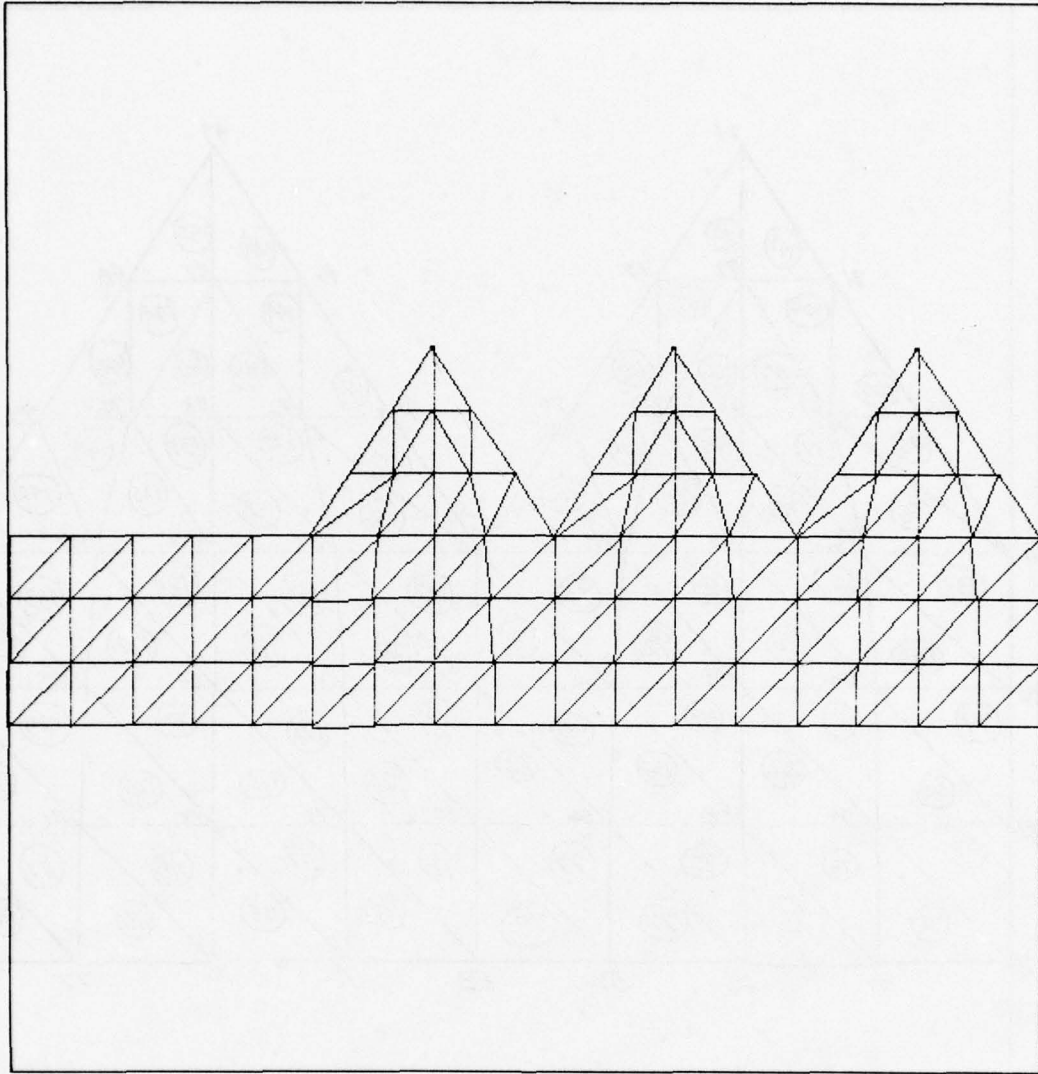

FIG. B-30 NASTRAN STRUCTURAL PLOT

LISTING OF PUNCHED NASTRAN BULK DATA CARDS  
PROBLEM B-III REPEATED SECTION

```
*****  
*****  
**  
**      JUNCTION INPUT GENERATOR PROGRAM      (JIG)  **  
**  
*****  
*****
```

\*\*\* SAMPLE 3 - REPEATED SECTION TYPE \*\*\*

```
NST =      2  
NGS =      1  
NES =      1  
NPOP =     1  
MID =      5  
NGP =      0  
IDELT =     0  
NSECT =     1  
NT( 1) =    1      DELTZ( 1) =    0.0000  
NT( 2) =    3      DELTZ( 2) =    2.0000
```

NSWC/WOL TR 77-85

	I	J	Z(I,J)	X(I,J)	CODE(I,J)			
	1	1	0.00000	1.00000	1			
	2	1	.50000	1.00000	1			
	3	1	1.00000	1.00000	1			
	4	1	1.50000	1.00000	1			
	5	1	2.00000	1.00000	1			
	6	1	2.50000	1.00000	1			
	1	2	0.00000	1.50000	1			
	2	2	.49999	1.49999	0			
	3	2	1.00000	1.50000	0			
	4	2	1.49999	1.50000	0			
	5	2	2.00001	1.50001	0			
	6	2	2.50000	1.50000	1			
	1	3	0.00000	2.00000	1			
	2	3	.50000	2.00000	0			
	3	3	1.00000	2.00001	0			
	4	3	1.50001	2.00001	0			
	5	3	2.00001	2.00001	0			
	6	3	2.50000	2.00000	1			
	1	4	0.00000	2.50000	1			
	2	4	.50000	2.50000	1			
	3	4	1.00000	2.50000	1			
	4	4	1.50000	2.50000	1			
	5	4	2.00000	2.50000	1			
	6	4	2.50000	2.50000	1			
GRID		1	0	1.0000	0.0000	0.0000	0	456
GRID		2	0	1.0000	0.0000	.5000	0	456
GRID		3	0	1.0000	0.0000	1.0000	0	456
GRID		4	0	1.0000	0.0000	1.5000	0	456
GRID		5	0	1.0000	0.0000	2.0000	0	456
GRID		6	0	1.0000	0.0000	2.5000	0	456
GRID		7	0	1.5000	0.0000	0.0000	0	456
GRID		8	0	1.5000	0.0000	.5000	0	456
CTRIARG		1	8	7	1	0.0000	5	
CTRIARG		2	1	2	8	0.0000	5	
GRID		9	0	1.5000	0.0000	1.0000	0	456
CTRIARG		3	9	8	2	0.0000	5	
CTRIARG		4	2	3	9	0.0000	5	
GRID		10	0	1.5000	0.0000	1.5000	0	456
CTRIARG		5	10	9	3	0.0000	5	
CTRIARG		6	3	4	10	0.0000	5	
GRID		11	0	1.5000	0.0000	2.0000	0	456
CTRIARG		7	11	10	4	0.0000	5	
CTRIARG		8	4	5	11	0.0000	5	
GRID		12	0	1.5000	0.0000	2.5000	0	456
CTRIARG		9	12	11	5	0.0000	5	
CTRIARG		10	5	6	12	0.0000	5	
GRID		13	0	2.0000	0.0000	0.0000	0	456
GRID		14	0	2.0000	0.0000	.5000	0	456
CTRIARG		11	14	13	7	0.0000	5	
CTRIARG		12	7	8	14	0.0000	5	
GRID		15	0	2.0000	0.0000	1.0000	0	456
CTRIARG		13	15	14	8	0.0000	5	
CTRIARG		14	8	9	15	0.0000	5	
GRID		16	0	2.0000	0.0000	1.5000	0	456
CTRIARG		15	16	15	9	0.0000	5	
CTRIARG		16	9	10	16	0.0000	5	
GRID		17	0	2.0000	0.0000	2.0000	0	456
CTRIARG		17	17	16	10	0.0000	5	

NSWC/WOL TR 77-85

CTRIARG	18	10	11	17	0.0000	5	
GRID	18	0	2.0000	0.0000	2.5000	0	456
CTRIARG	19	18	17	11	0.0000	5	
CTRIARG	20	11	12	18	0.0000	5	
GRID	19	0	2.5000	0.0000	0.0000	0	456
GRID	20	0	2.5000	0.0000	.5000	0	456
CTRIARG	21	20	19	13	0.0000	5	
CTRIARG	22	13	14	20	0.0000	5	
GRID	21	0	2.5000	0.0000	1.0000	0	456
CTRIARG	23	21	20	14	0.0000	5	
CTRIARG	24	14	15	21	0.0000	5	
GRID	22	0	2.5000	0.0000	1.5000	0	456
CTRIARG	25	22	21	15	0.0000	5	
CTRIARG	26	15	16	22	0.0000	5	
GRID	23	0	2.5000	0.0000	2.0000	0	456
CTRIARG	27	23	22	16	0.0000	5	
CTRIARG	28	16	17	23	0.0000	5	
GRID	24	0	2.5000	0.0000	2.5000	0	456
CTRIARG	29	24	23	17	0.0000	5	
CTRIARG	30	17	18	24	0.0000	5	

	I	J	Z(I,J)	X(I,J)	CODE(I,J)			
	1	1	2.50000	1.00000	1			
	2	1	3.00000	1.00000	1			
	3	1	3.50000	1.00000	1			
	4	1	4.00000	1.00000	1			
	5	1	4.50000	1.00000	1			
	1	2	2.50000	1.50000	1			
	2	2	3.00316	1.49998	0			
	3	2	3.49999	1.49999	0			
	4	2	3.99679	1.49998	0			
	5	2	4.50000	1.50000	1			
	1	3	2.50000	2.00000	1			
	2	3	3.01274	1.99998	0			
	3	3	3.49998	1.99999	0			
	4	3	3.98724	2.00000	0			
	5	3	4.50000	2.00000	1			
	1	4	2.50000	2.50000	1			
	2	4	3.04785	2.50000	0			
	3	4	3.50004	2.50003	0			
	4	4	3.95217	2.50002	0			
	5	4	4.50000	2.50000	1			
	1	5	2.83335	3.00000	1			
	2	5	3.17863	2.99999	0			
	3	5	3.50002	3.00001	0			
	4	5	3.82133	2.99998	0			
	5	5	4.16665	3.00000	1			
	1	6	3.16670	3.50000	1			
	2	6	3.33335	3.50000	1			
	3	6	3.50000	3.50000	1			
	4	6	3.66665	3.50000	1			
	5	6	3.83330	3.50000	1			
	1	7	3.50000	4.00000	1			
GRID		25	0	1.0000	0.0000	3.0000	0	456
GRID		26	0	1.0000	0.0000	3.5000	0	456
GRID		27	0	1.0000	0.0000	4.0000	0	456
GRID		28	0	1.0000	0.0000	4.5000	0	456
GRID		29	0	1.5000	0.0000	3.0032	0	456
CTRIARG		31	29	12	6	0.0000	5	
CTRIARG		32	6	25	29	0.0000	5	
GRID		30	0	1.5000	0.0000	3.5000	0	456

NSWC/WOL TR 77-85

CTRIARG	33	30	29	25	0.0000	5	
CTRIARG	34	25	26	30	0.0000	5	
GRID	31	0	1.5000	0.0000	3.9968	0	456
CTRIARG	35	31	30	26	0.0000	5	
CTRIARG	36	26	27	31	0.0000	5	
GRID	32	0	1.5000	0.0000	4.5000	0	456
CTRIARG	37	32	31	27	0.0000	5	
CTRIARG	38	27	28	32	0.0000	5	
GRID	33	0	2.0000	0.0000	3.0127	0	456
CTRIARG	39	33	18	12	0.0000	5	
CTRIARG	40	12	29	33	0.0000	5	
GRID	34	0	2.0000	0.0000	3.5000	0	456
CTRIARG	41	34	33	29	0.0000	5	
CTRIARG	42	29	30	34	0.0000	5	
GRID	35	0	2.0000	0.0000	3.9872	0	456
CTRIARG	43	35	34	30	0.0000	5	
CTRIARG	44	30	31	35	0.0000	5	
GRID	36	0	2.0000	0.0000	4.5000	0	456
CTRIARG	45	36	35	31	0.0000	5	
CTRIARG	46	31	32	36	0.0000	5	
GRID	37	0	2.5000	0.0000	3.0478	0	456
CTRIARG	47	37	24	18	0.0000	5	
CTRIARG	48	18	33	37	0.0000	5	
GRID	38	0	2.5000	0.0000	3.5000	0	456
CTRIARG	49	38	37	33	0.0000	5	
CTRIARG	50	33	34	38	0.0000	5	
GRID	39	0	2.5000	0.0000	3.9522	0	456
CTRIARG	51	39	38	34	0.0000	5	
CTRIARG	52	34	35	39	0.0000	5	
GRID	40	0	2.5000	0.0000	4.5000	0	456
CTRIARG	53	40	39	35	0.0000	5	
CTRIARG	54	35	36	40	0.0000	5	
GRID	41	0	3.0000	0.0000	2.8334	0	456
GRID	42	0	3.0000	0.0000	3.1786	0	456
CTRIARG	55	42	41	24	0.0000	5	
CTRIARG	56	24	37	42	0.0000	5	
GRID	43	0	3.0000	0.0000	3.5000	0	456
CTRIARG	57	43	42	37	0.0000	5	
CTRIARG	58	37	38	43	0.0000	5	
GRID	44	0	3.0000	0.0000	3.8213	0	456
CTRIARG	59	44	43	38	0.0000	5	
CTRIARG	60	38	39	44	0.0000	5	
GRID	45	0	3.0000	0.0000	4.1667	0	456
CTRIARG	61	45	44	39	0.0000	5	
CTRIARG	62	39	40	45	0.0000	5	
GRID	46	0	3.5000	0.0000	3.1667	0	456
GRID	47	0	3.5000	0.0000	3.5000	0	456
CTRIARG	63	41	42	46	0.0000	5	
CTRIARG	64	42	47	46	0.0000	5	
CTRIARG	65	42	43	47	0.0000	5	
GRID	48	0	3.5000	0.0000	3.8333	0	456
CTRIARG	66	43	44	47	0.0000	5	
CTRIARG	67	44	48	47	0.0000	5	
CTRIARG	68	44	45	48	0.0000	5	
GRID	49	0	4.0000	0.0000	3.5000	0	456
CTRIARG	69	47	49	46	0.0000	5	
CTRIARG	70	48	49	47	0.0000	5	

I	J	Z(I,J)	X(I,J)	CODE(I,J)
1	1	4.50000	1.00000	1
2	1	5.00000	1.00000	1

NSWC/WOL TR 77-85

3	1	5.50000	1.00000	1
4	1	6.00000	1.00000	1
5	1	6.50000	1.00000	1
1	2	4.50000	1.50000	1
2	2	5.00316	1.49998	0
3	2	5.49999	1.49999	0
4	2	5.99679	1.49998	0
5	2	6.50000	1.50000	1
1	3	4.50000	2.00000	1
2	3	5.01274	1.99998	0
3	3	5.49998	1.99999	0
4	3	5.98724	2.00000	0
5	3	6.50000	2.00000	1
1	4	4.50000	2.50000	1
2	4	5.04785	2.50000	0
3	4	5.50004	2.50003	0
4	4	5.95217	2.50002	0
5	4	6.50000	2.50000	1
1	5	4.83335	3.00000	1
2	5	5.17863	2.99999	0
3	5	5.50002	3.00001	0
4	5	5.82133	2.99998	0
5	5	6.16665	3.00000	1
1	6	5.16670	3.50000	1
2	6	5.33335	3.50000	1
3	6	5.50000	3.50000	1
4	6	5.66665	3.50000	1
5	6	5.83330	3.50000	1
1	7	5.50000	4.00000	1

GRID	50	0	1.0000	0.0000	5.0000	0	456
GRID	51	0	1.0000	0.0000	5.5000	0	456
GRID	52	0	1.0000	0.0000	6.0000	0	456
GRID	53	0	1.0000	0.0000	6.5000	0	456
GRID	54	0	1.5000	0.0000	5.0032	0	456
CTRIARG	71	54	32	28	0.0000	5	
CTRIARG	72	28	50	54	0.0000	5	
GRID	55	0	1.5000	0.0000	5.5000	0	456
CTRIARG	73	55	54	50	0.0000	5	
CTRIARG	74	50	51	55	0.0000	5	
GRID	56	0	1.5000	0.0000	5.9968	0	456
CTRIARG	75	56	55	51	0.0000	5	
CTRIARG	76	51	52	56	0.0000	5	
GRID	57	0	1.5000	0.0000	6.5000	0	456
CTRIARG	77	57	56	52	0.0000	5	
CTRIARG	78	52	53	57	0.0000	5	
GRID	58	0	2.0000	0.0000	5.0127	0	456
CTRIARG	79	58	36	32	0.0000	5	
CTRIARG	80	32	54	58	0.0000	5	
GRID	59	0	2.0000	0.0000	5.5000	0	456
CTRIARG	81	59	58	54	0.0000	5	
CTRIARG	82	54	55	59	0.0000	5	
GRID	60	0	2.0000	0.0000	5.9872	0	456
CTRIARG	83	60	59	55	0.0000	5	
CTRIARG	84	55	56	60	0.0000	5	
GRID	61	0	2.0000	0.0000	6.5000	0	456
CTRIARG	85	61	60	56	0.0000	5	
CTRIARG	86	56	57	61	0.0000	5	
GRID	62	0	2.5000	0.0000	5.0478	0	456
CTRIARG	87	62	40	36	0.0000	5	
CTRIARG	88	36	58	62	0.0000	5	
GRID	63	0	2.5000	0.0000	5.5000	0	456
CTRIARG	89	63	62	58	0.0000	5	
CTRIARG	90	58	59	63	0.0000	5	
GRID	64	0	2.5000	0.0000	5.9522	0	456

NSWC/WOL TR 77-85

CTRIARG	91	64	63	59	0.0000	5	
CTRIARG	92	59	60	64	0.0000	5	
GRID	65	0	2.5000	0.0000	6.5000	0	+56
CTRIARG	93	65	64	60	0.0000	5	
CTRIARG	94	60	61	65	0.0000	5	
GRID	66	0	3.0000	0.0000	4.8334	0	+56
GRID	67	0	3.0000	0.0000	5.1786	0	+56
CTRIARG	95	67	66	40	0.0000	5	
CTRIARG	96	40	62	67	0.0000	5	
GRID	68	0	3.0000	0.0000	5.5000	0	+56
CTRIARG	97	68	67	62	0.0000	5	
CTRIARG	98	62	63	68	0.0000	5	
GRID	69	0	3.0000	0.0000	5.8213	0	+56
CTRIARG	99	69	68	63	0.0000	5	
CTRIARG	100	63	64	69	0.0000	5	
GRID	70	0	3.0000	0.0000	6.1667	0	+56
CTRIARG	101	70	69	64	0.0000	5	
CTRIARG	102	64	65	70	0.0000	5	
GRID	71	0	3.5000	0.0000	5.1667	0	+56
GRID	72	0	3.5000	0.0000	5.5000	0	+56
CTRIARG	103	66	67	71	0.0000	5	
CTRIARG	104	67	72	71	0.0000	5	
CTRIARG	105	67	68	72	0.0000	5	
GRID	73	0	3.5000	0.0000	5.8333	0	+56
CTRIARG	106	68	69	72	0.0000	5	
CTRIARG	107	69	73	72	0.0000	5	
CTRIARG	108	69	70	73	0.0000	5	
GRID	74	0	4.0000	0.0000	5.5000	0	+56
CTRIARG	109	72	74	71	0.0000	5	
CTRIARG	110	73	74	72	0.0000	5	

I	J	Z(I,J)	X(I,J)	CODE(I,J)
1	1	6.50000	1.00000	1
2	1	7.00000	1.00000	1
3	1	7.50000	1.00000	1
4	1	8.00000	1.00000	1
5	1	8.50000	1.00000	1
1	2	6.50000	1.50000	1
2	2	7.00316	1.49998	0
3	2	7.49999	1.49999	0
4	2	7.99679	1.49998	0
5	2	8.50000	1.50000	1
1	3	6.50000	2.00000	1
2	3	7.01274	1.99998	0
3	3	7.49998	1.99999	0
4	3	7.98724	2.00000	0
5	3	8.50000	2.00000	1
1	4	6.50000	2.50000	1
2	4	7.04785	2.50000	0
3	4	7.50004	2.50003	0
4	4	7.95217	2.50002	0
5	4	8.50000	2.50000	1
1	5	6.83335	3.00000	1
2	5	7.17863	2.99999	0
3	5	7.50002	3.00001	0
4	5	7.82133	2.99998	0
5	5	8.16665	3.00000	1
1	6	7.16670	3.50000	1
2	6	7.33335	3.50000	1
3	6	7.50000	3.50000	1
4	6	7.66665	3.50000	1

## NSWC/WOL TR 77-85

	5 1	6 7	7.83330 7.50000	3.50000 4.00000	1 1				
GRID			75	0	1.0000	0.0000	7.0000	0	456
GRID			76	0	1.0000	0.0000	7.5000	0	456
GRID			77	0	1.0000	0.0000	8.0000	0	456
GRID			78	0	1.0000	0.0000	8.5000	0	456
GRID			79	0	1.5000	0.0000	7.0032	0	456
CTRIARG		111	79	57	53	0.0000		5	
CTRIARG		112	53	75	79	0.0000		5	
GRID		80	0	1.5000	0.0000	7.5000		0	456
CTRIARG		113	80	79	75	0.0000		5	
CTRIARG		114	75	76	80	0.0000		5	
GRID		81	0	1.5000	0.0000	7.9968		0	456
CTRIARG		115	81	80	76	0.0000		5	
CTRIARG		116	76	77	81	0.0000		5	
GRID		82	0	1.5000	0.0000	8.5000		0	456
CTRIARG		117	82	81	77	0.0000		5	
CTRIARG		118	77	78	82	0.0000		5	
GRID		83	0	2.0000	0.0000	7.0127		0	456
CTRIARG		119	83	61	57	0.0000		5	
CTRIARG		120	57	79	83	0.0000		5	
GRID		84	0	2.0000	0.0000	7.5000		0	456
CTRIARG		121	84	83	79	0.0000		5	
CTRIARG		122	79	80	84	0.0000		5	
GRID		85	0	2.0000	0.0000	7.9872		0	456
CTRIARG		123	85	84	80	0.0000		5	
CTRIARG		124	80	81	85	0.0000		5	
GRID		86	0	2.0000	0.0000	8.5000		0	456
CTRIARG		125	86	85	81	0.0000		5	
CTRIARG		126	81	82	86	0.0000		5	
GRID		87	0	2.5000	0.0000	7.0478		0	456
CTRIARG		127	87	65	61	0.0000		5	
CTRIARG		128	61	83	87	0.0000		5	
GRID		88	0	2.5000	0.0000	7.5000		0	456
CTRIARG		129	88	87	83	0.0000		5	
CTRIARG		130	83	84	88	0.0000		5	
GRID		89	0	2.5000	0.0000	7.9522		0	456
CTRIARG		131	89	88	84	0.0000		5	
CTRIARG		132	84	85	89	0.0000		5	
GRID		90	0	2.5000	0.0000	8.5000		0	456
CTRIARG		133	90	89	85	0.0000		5	
CTRIARG		134	85	86	90	0.0000		5	
GRID		91	0	3.0000	0.0000	6.8334		0	456
GRID		92	0	3.0000	0.0000	7.1786		0	456
CTRIARG		135	92	91	65	0.0000		5	
CTRIARG		136	65	87	92	0.0000		5	
GRID		93	0	3.0000	0.0000	7.5000		0	456
CTRIARG		137	93	92	87	0.0000		5	
CTRIARG		138	87	88	93	0.0000		5	
GRID		94	0	3.0000	0.0000	7.8213		0	456
CTRIARG		139	94	93	88	0.0000		5	
CTRIARG		140	88	89	94	0.0000		5	
GRID		95	0	3.0000	0.0000	8.1667		0	456
CTRIARG		141	95	94	89	0.0000		5	
CTRIARG		142	89	90	95	0.0000		5	
GRID		96	0	3.5000	0.0000	7.1667		0	456
GRID		97	0	3.5000	0.0000	7.5000		0	456
CTRIARG		143	91	92	96	0.0000		5	
CTRIARG		144	92	97	96	0.0000		5	
CTRIARG		145	92	93	97	0.0000		5	
GRID		98	0	3.5000	0.0000	7.8333		0	456
CTRIARG		146	93	94	97	0.0000		5	
CTRIARG		147	94	98	97	0.0000		5	
CTRIARG		148	94	95	98	0.0000		5	

NSWC/WOL TR 77-85

GRID	99	0	4.0000	0.0000	7.5000	0	456
CTRIARG	149	97	99	96	0.0000	5	
CTRIARG	150	98	99	97	0.0000	5	

PROBLEM B-IV

VARIABLE THETA

This problem demonstrates the variable theta feature of JIG. Figure B-31 shows the planned finite element model and configuration of a tapered cylindrical shell using the variable theta feature. A complete listing of the data input is shown in Figure B-32. Figure B-33 shows the grid point and element numbers as generated by JIG. Figures B-34 and B-35 give NASTRAN structural plots and are followed by a listing of the JIG punched output.

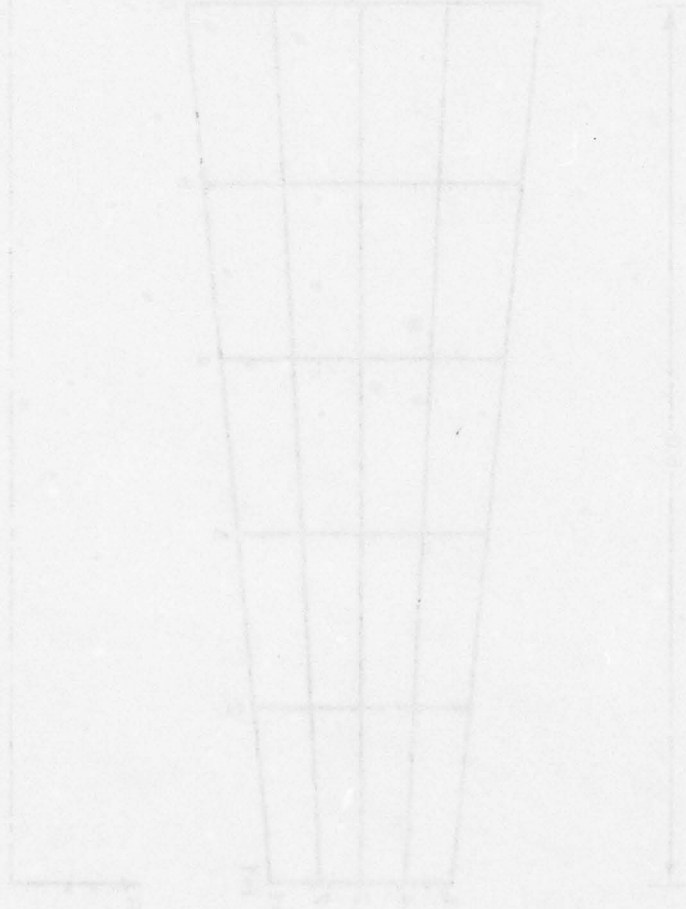

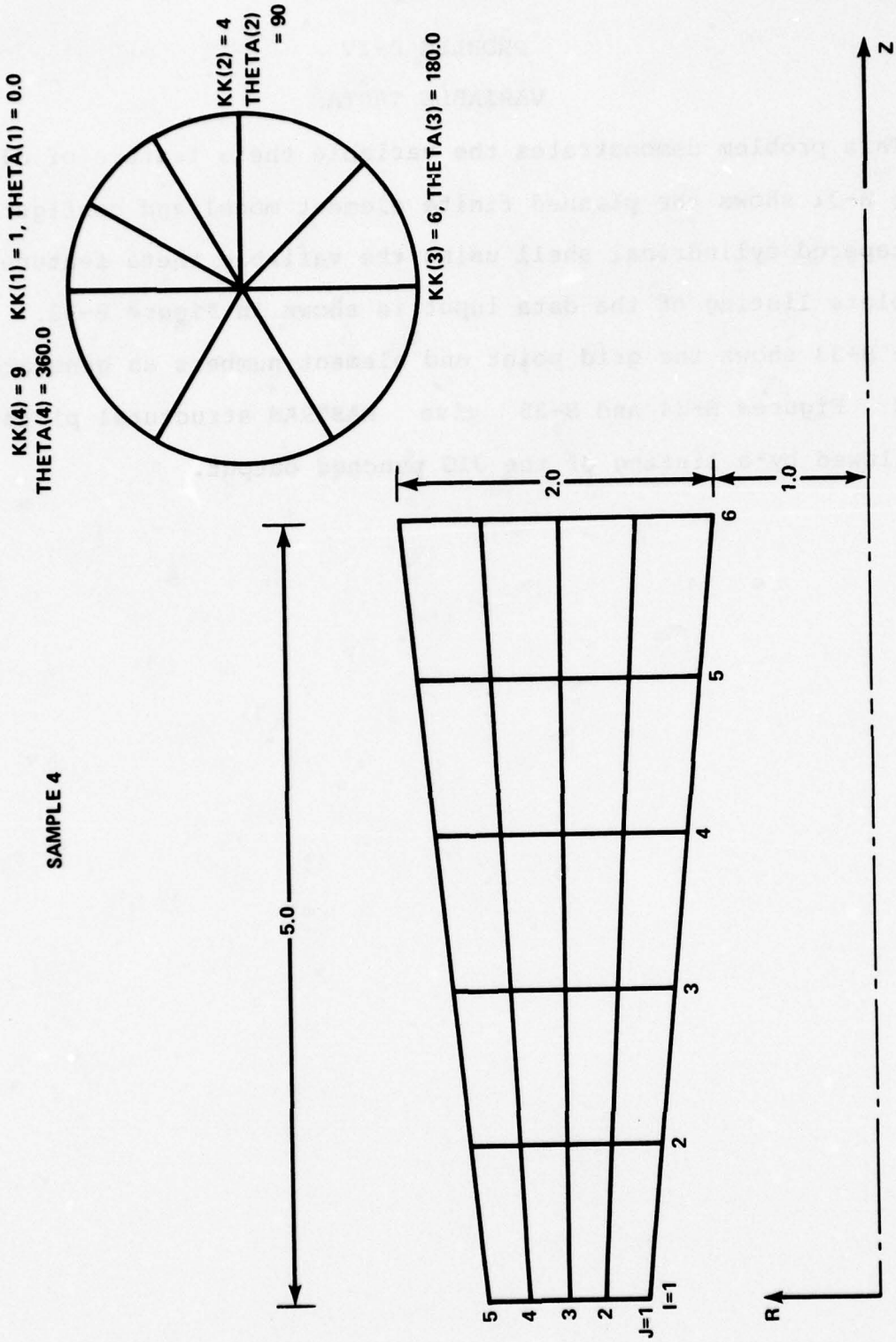

FIG. B-31 PLANNED FINITE ELEMENT MODEL AND CONFIGURATION OF A THICK TAPERED CYLINDRICAL SHELL USING THE VARIABLE THETA FEATURE.

```

*** SAMPLE 4 - VARIABLE THETA ***
  1  1  1  3  5  0  1  1
  1
  0.0
  3  0  50
  1  0.0  4  90.0  6  180.0  9  360.0
  0.0  360.0
  1  5
  4  1  5  1  6  0  0  0  0  0  456  0
  1  1  0.0  1.5  1  6  1  5.0  1.0  1
  6  5  5.0  3.0  1  1  5  0.0  2.5  1
    
```

FIG. B-32 DATA INPUT PROBLEM B-IV

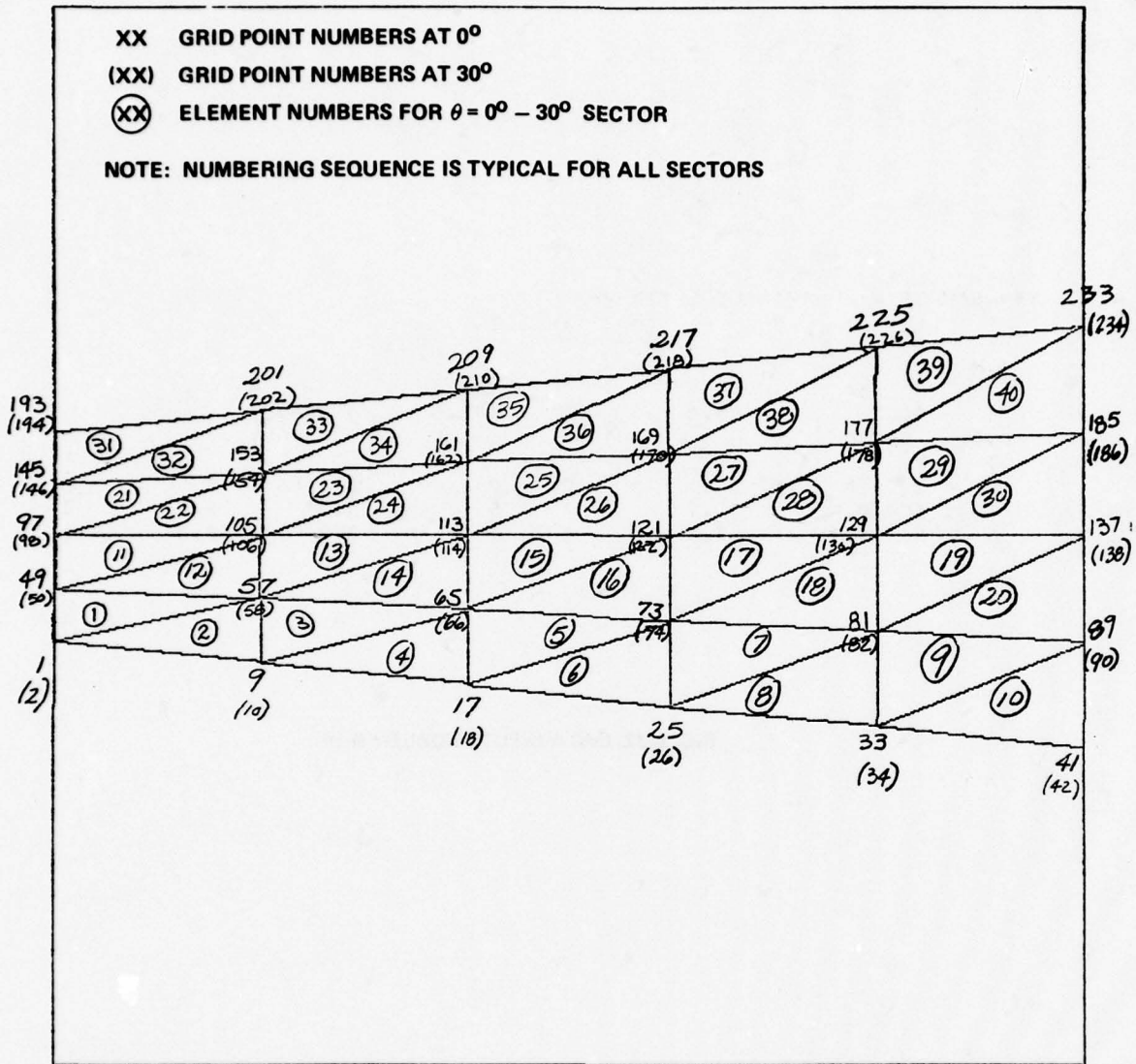

FIG. B-33 GRID POINT AND ELEMENT NUMBERS

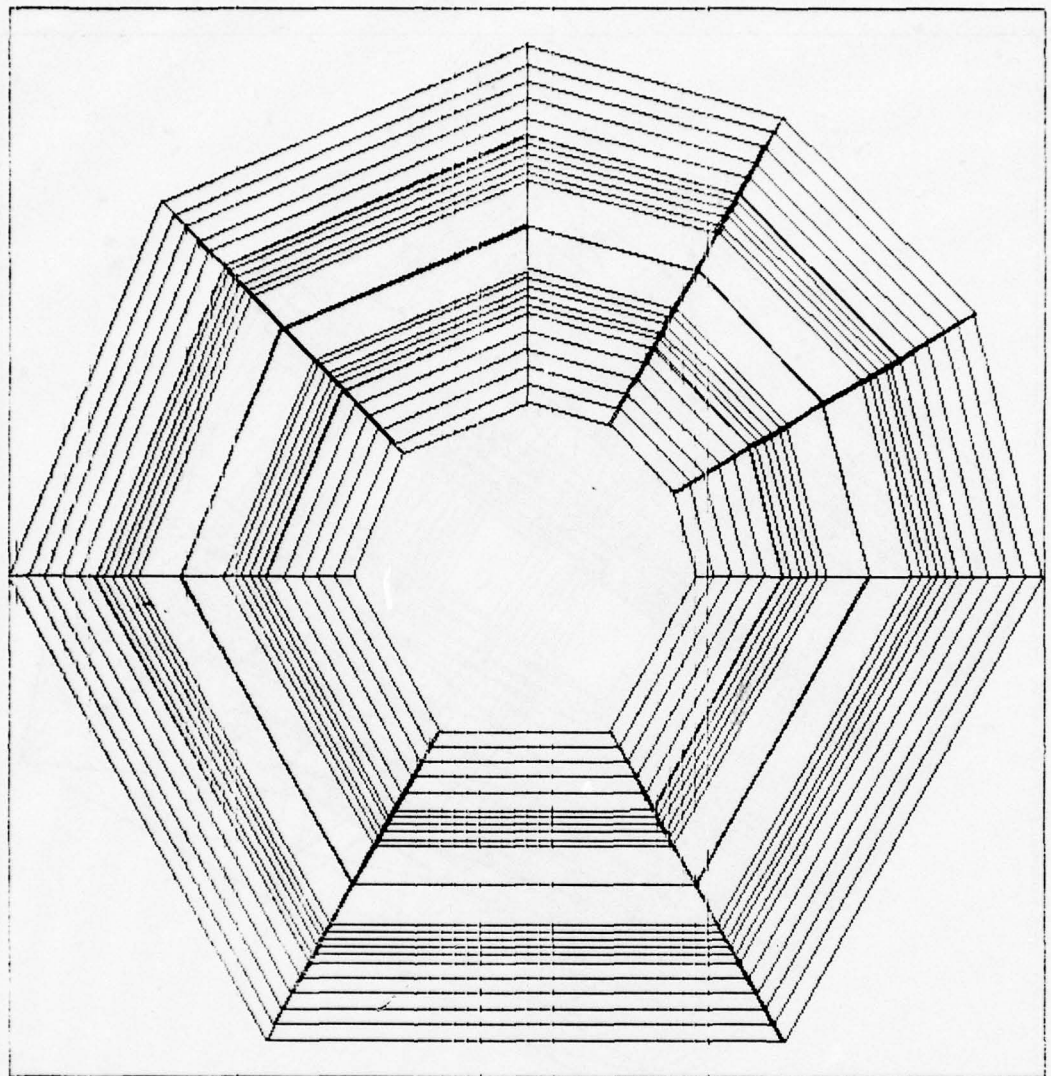
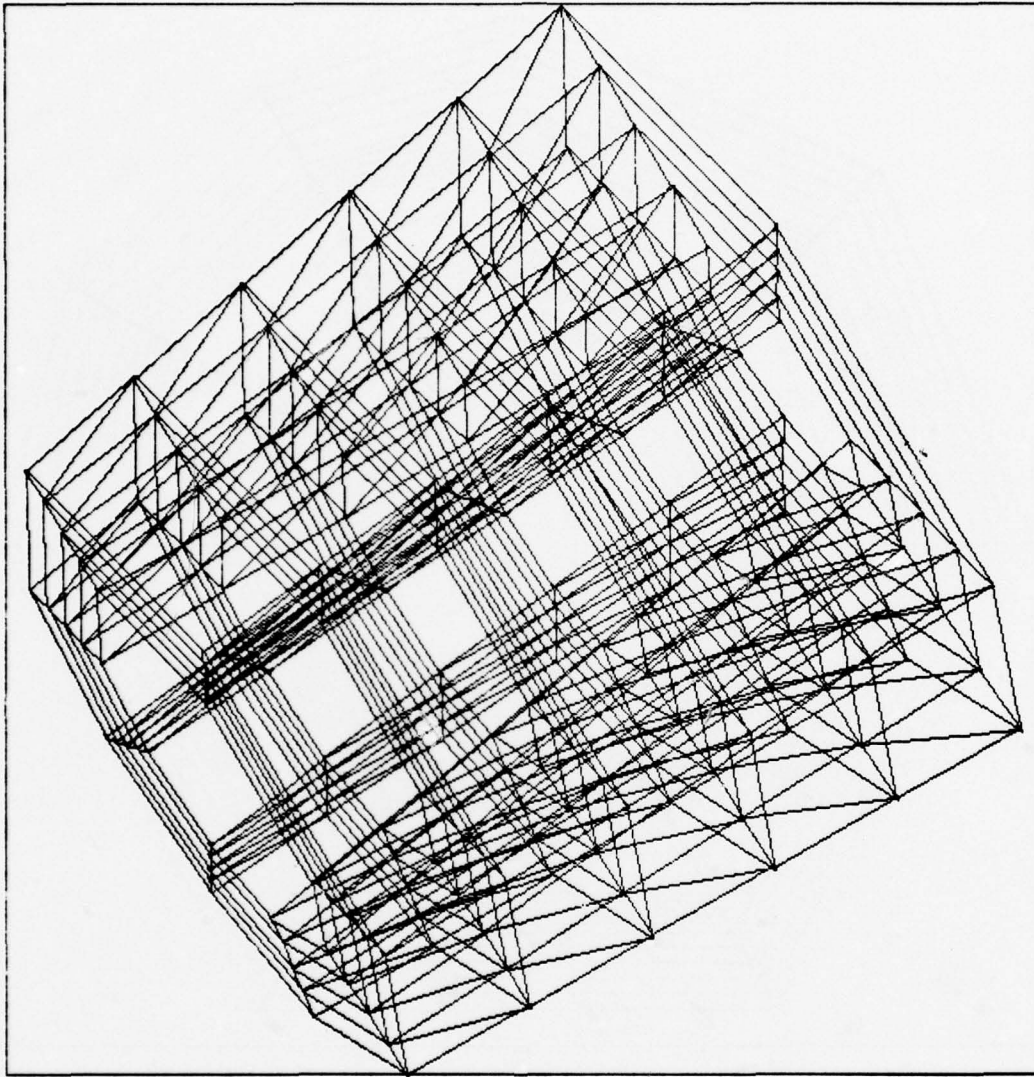

FIG. B-34 NASTRAN STRUCTUAL PLOT. END VIEW



**FIG. B-35 NASTRAN STRUCTURAL PLOT. ROTATED VIEW**

LISTING OF PUNCHED NASTRAN BULK DATA CARDS  
PROBLEM B-IV VARIABLE THETA

```
*****  
*****  
** JUNCTION INPUT GENERATOR PROGRAM (JIG) **  
**  
*****  
*****
```

## \*\*\* SAMPLE 4 - VARIABLE THETA \*\*\*

```
NST = 1  
NGS = 1  
NES = 1  
NPOP = 3  
MID = 5  
NGP = 0  
IDELT = 1  
NSECT = 1  
NT( 1) = 1 DELTZ( 1) = 0.0000  
NDT = 3  
ICLOSE = 0  
DELGP = 50  
KK( 1) = 1 THETA( 1) = 0.0000  
KK( 2) = 4 THETA( 2) = 90.0000  
KK( 3) = 5 THETA( 3) = 180.0000  
KK( 4) = 9 THETA( 4) = 360.0000  
BETA( 1) = 0.0000  
BETA( 2) = 360.0000  
JB( 1) = 1 JF( 1) = 5
```

NSWC/WOL TR 77-85

I	J	Z(I,J)	X(I,J)	CODE(I,J)		
1	1	0.00000	1.50000	1		
2	1	1.00000	1.40000	1		
3	1	2.00000	1.30000	1		
4	1	3.00000	1.20000	1		
5	1	4.00000	1.10000	1		
6	1	5.00000	1.00000	1		
1	2	0.00000	1.75000	1		
2	2	1.00000	1.70000	0		
3	2	2.00001	1.65001	0		
4	2	3.00002	1.60000	0		
5	2	3.99999	1.54999	0		
6	2	5.00000	1.50000	1		
1	3	0.00000	2.00000	1		
2	3	1.00003	2.00002	0		
3	3	2.00002	2.00001	0		
4	3	3.00000	1.99999	0		
5	3	4.00000	2.00000	0		
6	3	5.00000	2.00000	1		
1	4	0.00000	2.25000	1		
2	4	1.00002	2.30001	0		
3	4	1.99998	2.34999	0		
4	4	3.00000	2.40000	0		
5	4	4.00000	2.44999	0		
6	4	5.00000	2.50000	1		
1	5	0.00000	2.50000	1		
2	5	1.00000	2.60000	1		
3	5	2.00000	2.70000	1		
4	5	3.00000	2.80000	1		
5	5	4.00000	2.90000	1		
6	5	5.00000	3.00000	1		
GRID		1	1.5000	0.0000	0.0000	1 456
GRID		2	1.5000	30.0000	0.0000	1 456
GRID		3	1.5000	60.0000	0.0000	1 456
GRID		4	1.5000	90.0000	0.0000	1 456
GRID		5	1.5000	135.0000	0.0000	1 456
GRID		6	1.5000	180.0000	0.0000	1 456
GRID		7	1.5000	240.0000	0.0000	1 456
GRID		8	1.5000	300.0000	0.0000	1 456
GRID		9	1.4000	0.0000	1.0000	1 456
GRID		10	1.4000	30.0000	1.0000	1 456
GRID		11	1.4000	60.0000	1.0000	1 456
GRID		12	1.4000	90.0000	1.0000	1 456
GRID		13	1.4000	135.0000	1.0000	1 456
GRID		14	1.4000	180.0000	1.0000	1 456
GRID		15	1.4000	240.0000	1.0000	1 456
GRID		16	1.4000	300.0000	1.0000	1 456
GRID		17	1.3000	0.0000	2.0000	1 456
GRID		18	1.3000	30.0000	2.0000	1 456
GRID		19	1.3000	60.0000	2.0000	1 456
GRID		20	1.3000	90.0000	2.0000	1 456
GRID		21	1.3000	135.0000	2.0000	1 456
GRID		22	1.3000	180.0000	2.0000	1 456
GRID		23	1.3000	240.0000	2.0000	1 456
GRID		24	1.3000	300.0000	2.0000	1 456
GRID		25	1.2000	0.0000	3.0000	1 456
GRID		26	1.2000	30.0000	3.0000	1 456
GRID		27	1.2000	60.0000	3.0000	1 456
GRID		28	1.2000	90.0000	3.0000	1 456

NSWC/WOL TR 77-85

GRID	29	1	1.2000	135.0000	3.0000	1	456		
GRID	30	1	1.2000	180.0000	3.0000	1	456		
GRID	31	1	1.2000	240.0000	3.0000	1	456		
GRID	32	1	1.2000	300.0000	3.0000	1	456		
GRID	33	1	1.1000	0.0000	4.0000	1	456		
GRID	34	1	1.1000	30.0000	4.0000	1	456		
GRID	35	1	1.1000	60.0000	4.0000	1	456		
GRID	36	1	1.1000	90.0000	4.0000	1	456		
GRID	37	1	1.1000	135.0000	4.0000	1	456		
GRID	38	1	1.1000	180.0000	4.0000	1	456		
GRID	39	1	1.1000	240.0000	4.0000	1	456		
GRID	40	1	1.1000	300.0000	4.0000	1	456		
GRID	41	1	1.0000	0.0000	5.0000	1	456		
GRID	42	1	1.0000	30.0000	5.0000	1	456		
GRID	43	1	1.0000	60.0000	5.0000	1	456		
GRID	44	1	1.0000	90.0000	5.0000	1	456		
GRID	45	1	1.0000	135.0000	5.0000	1	456		
GRID	46	1	1.0000	180.0000	5.0000	1	456		
GRID	47	1	1.0000	240.0000	5.0000	1	456		
GRID	48	1	1.0000	300.0000	5.0000	1	456		
GRID	49	1	1.7500	0.0000	0.0000	1	456		
GRID	50	1	1.7500	30.0000	0.0000	1	456		
GRID	51	1	1.7500	60.0000	0.0000	1	456		
GRID	52	1	1.7500	90.0000	0.0000	1	456		
GRID	53	1	1.7500	135.0000	0.0000	1	456		
GRID	54	1	1.7500	180.0000	0.0000	1	456		
GRID	55	1	1.7500	240.0000	0.0000	1	456		
GRID	56	1	1.7500	300.0000	0.0000	1	456		
GRID	57	1	1.7000	0.0000	1.0000	1	456		
GRID	58	1	1.7000	30.0000	1.0000	1	456		
GRID	59	1	1.7000	60.0000	1.0000	1	456		
GRID	60	1	1.7000	90.0000	1.0000	1	456		
GRID	61	1	1.7000	135.0000	1.0000	1	456		
GRID	62	1	1.7000	180.0000	1.0000	1	456		
GRID	63	1	1.7000	240.0000	1.0000	1	456		
GRID	64	1	1.7000	300.0000	1.0000	1	456		
CWEDGE	1	5	57	49	1	58	50	2	
CWEDGE	51	5	58	50	2	59	51	3	
CWEDGE	101	5	59	51	3	60	52	4	
CWEDGE	151	5	60	52	4	61	53	5	
CWEDGE	201	5	61	53	5	62	54	6	
CWEDGE	251	5	62	54	6	63	55	7	
CWEDGE	301	5	63	55	7	64	56	8	
CWEDGE	351	5	64	56	8	57	49	1	
CWEDGE	2	5	1	9	57	2	10	58	
CWEDGE	52	5	2	10	58	3	11	59	
CWEDGE	102	5	3	11	59	4	12	60	
CWEDGE	152	5	4	12	60	5	13	61	
CWEDGE	202	5	5	13	61	6	14	62	
CWEDGE	252	5	6	14	62	7	15	63	
CWEDGE	302	5	7	15	63	8	16	64	
CWEDGE	352	5	8	16	64	1	9	57	
GRID	65	1	1.6500	0.0000	2.0000	1	456		
GRID	66	1	1.6500	30.0000	2.0000	1	456		
GRID	67	1	1.6500	60.0000	2.0000	1	456		
GRID	68	1	1.6500	90.0000	2.0000	1	456		
GRID	69	1	1.6500	135.0000	2.0000	1	456		
GRID	70	1	1.6500	180.0000	2.0000	1	456		
GRID	71	1	1.6500	240.0000	2.0000	1	456		
GRID	72	1	1.6500	300.0000	2.0000	1	456		
CWEDGE	3	5	65	57	9	60	58	10	
CWEDGE	53	5	66	58	10	67	59	11	
CWEDGE	103	5	67	59	11	68	60	12	
CWEDGE	153	5	68	60	12	69	61	13	

## NSWC/WOL TR 77-85

CWEDGE	203	5	69	61	13	70	62	14
CWEDGE	253	5	70	62	14	71	63	15
CWEDGE	303	5	71	63	15	72	64	16
CWEDGE	353	5	72	64	16	65	57	9
CWEDGE	4	5	9	17	65	10	18	66
CWEDGE	54	5	10	18	66	11	19	67
CWEDGE	104	5	11	19	67	12	20	68
CWEDGE	154	5	12	20	68	13	21	69
CWEDGE	204	5	13	21	69	14	22	70
CWEDGE	254	5	14	22	70	15	23	71
CWEDGE	304	5	15	23	71	16	24	72
CWEDGE	354	5	16	24	72	9	17	65
GRID	73	1	1.6000	0.0000	3.0000	1	456	
GRID	74	1	1.6000	30.0000	3.0000	1	456	
GRID	75	1	1.6000	60.0000	3.0000	1	456	
GRID	76	1	1.6000	90.0000	3.0000	1	456	
GRID	77	1	1.6000	135.0000	3.0000	1	456	
GRID	78	1	1.6000	180.0000	3.0000	1	456	
GRID	79	1	1.6000	240.0000	3.0000	1	456	
GRID	80	1	1.6000	300.0000	3.0000	1	456	
CWEDGE	5	5	73	65	17	74	66	18
CWEDGE	55	5	74	66	18	75	67	19
CWEDGE	105	5	75	67	19	76	68	20
CWEDGE	155	5	76	68	20	77	69	21
CWEDGE	205	5	77	69	21	78	70	22
CWEDGE	255	5	78	70	22	79	71	23
CWEDGE	305	5	79	71	23	80	72	24
CWEDGE	355	5	80	72	24	73	65	17
CWEDGE	6	5	17	25	73	18	26	74
CWEDGE	56	5	18	26	74	19	27	75
CWEDGE	106	5	19	27	75	20	28	76
CWEDGE	156	5	20	28	76	21	29	77
CWEDGE	206	5	21	29	77	22	30	78
CWEDGE	256	5	22	30	78	23	31	79
CWEDGE	306	5	23	31	79	24	32	80
CWEDGE	356	5	24	32	80	17	25	73
GRID	81	1	1.5500	0.0000	4.0000	1	456	
GRID	82	1	1.5500	30.0000	4.0000	1	456	
GRID	83	1	1.5500	60.0000	4.0000	1	456	
GRID	84	1	1.5500	90.0000	4.0000	1	456	
GRID	85	1	1.5500	135.0000	4.0000	1	456	
GRID	86	1	1.5500	180.0000	4.0000	1	456	
GRID	87	1	1.5500	240.0000	4.0000	1	456	
GRID	88	1	1.5500	300.0000	4.0000	1	456	
CWEDGE	7	5	81	73	25	82	74	26
CWEDGE	57	5	82	74	26	83	75	27
CWEDGE	107	5	83	75	27	84	76	28
CWEDGE	157	5	84	76	28	85	77	29
CWEDGE	207	5	85	77	29	86	78	30
CWEDGE	257	5	86	78	30	87	79	31
CWEDGE	307	5	87	79	31	88	80	32
CWEDGE	357	5	88	80	32	81	73	25
CWEDGE	8	5	25	33	81	26	34	82
CWEDGE	58	5	26	34	82	27	35	83
CWEDGE	108	5	27	35	83	28	36	84
CWEDGE	158	5	28	36	84	29	37	85
CWEDGE	208	5	29	37	85	30	38	86
CWEDGE	258	5	30	38	86	31	39	87
CWEDGE	308	5	31	39	87	32	40	88
CWEDGE	358	5	32	40	88	25	33	81
GRID	89	1	1.5000	0.0000	5.0000	1	456	
GRID	90	1	1.5000	30.0000	5.0000	1	456	
GRID	91	1	1.5000	60.0000	5.0000	1	456	
GRID	92	1	1.5000	90.0000	5.0000	1	456	

## NSWC/WOL TR 77-85

GRID	93	1	1.5000	135.0000	5.0000	1	456	
GRID	94	1	1.5000	180.0000	5.0000	1	456	
GRID	95	1	1.5000	240.0000	5.0000	1	456	
GRID	96	1	1.5000	300.0000	5.0000	1	456	
CWEDGE	9	5	89	81	33	90	82	34
CWEDGE	59	5	90	82	34	91	83	35
CWEDGE	109	5	91	83	35	92	84	36
CWEDGE	159	5	92	84	36	93	85	37
CWEDGE	209	5	93	85	37	94	86	38
CWEDGE	259	5	94	86	38	95	87	39
CWEDGE	309	5	95	87	39	96	88	40
CWEDGE	359	5	96	88	40	89	81	33
CWEDGE	10	5	33	41	89	34	42	90
CWEDGE	60	5	34	42	90	35	43	91
CWEDGE	110	5	35	43	91	36	44	92
CWEDGE	160	5	36	44	92	37	45	93
CWEDGE	210	5	37	45	93	38	46	94
CWEDGE	260	5	38	46	94	39	47	95
CWEDGE	310	5	39	47	95	40	48	96
CWEDGE	360	5	40	48	96	33	41	89
GRID	97	1	2.0000	0.0000	0.0000	1	456	
GRID	98	1	2.0000	30.0000	0.0000	1	456	
GRID	99	1	2.0000	60.0000	0.0000	1	456	
GRID	100	1	2.0000	90.0000	0.0000	1	456	
GRID	101	1	2.0000	135.0000	0.0000	1	456	
GRID	102	1	2.0000	180.0000	0.0000	1	456	
GRID	103	1	2.0000	240.0000	0.0000	1	456	
GRID	104	1	2.0000	300.0000	0.0000	1	456	
GRID	105	1	2.0000	0.0000	1.0000	1	456	
GRID	106	1	2.0000	30.0000	1.0000	1	456	
GRID	107	1	2.0000	60.0000	1.0000	1	456	
GRID	108	1	2.0000	90.0000	1.0000	1	456	
GRID	109	1	2.0000	135.0000	1.0000	1	456	
GRID	110	1	2.0000	180.0000	1.0000	1	456	
GRID	111	1	2.0000	240.0000	1.0000	1	456	
GRID	112	1	2.0000	300.0000	1.0000	1	456	
CWEDGE	11	5	105	97	49	106	98	50
CWEDGE	61	5	106	98	50	107	99	51
CWEDGE	111	5	107	99	51	108	100	52
CWEDGE	161	5	108	100	52	109	101	53
CWEDGE	211	5	109	101	53	110	102	54
CWEDGE	261	5	110	102	54	111	103	55
CWEDGE	311	5	111	103	55	112	104	56
CWEDGE	361	5	112	104	56	105	97	49
CWEDGE	12	5	49	57	105	50	58	106
CWEDGE	62	5	50	58	106	51	59	107
CWEDGE	112	5	51	59	107	52	60	108
CWEDGE	162	5	52	60	108	53	61	109
CWEDGE	212	5	53	61	109	54	62	110
CWEDGE	262	5	54	62	110	55	63	111
CWEDGE	312	5	55	63	111	56	64	112
CWEDGE	362	5	56	64	112	49	57	105
GRID	113	1	2.0000	0.0000	2.0000	1	456	
GRID	114	1	2.0000	30.0000	2.0000	1	456	
GRID	115	1	2.0000	60.0000	2.0000	1	456	
GRID	116	1	2.0000	90.0000	2.0000	1	456	
GRID	117	1	2.0000	135.0000	2.0000	1	456	
GRID	118	1	2.0000	180.0000	2.0000	1	456	
GRID	119	1	2.0000	240.0000	2.0000	1	456	
GRID	120	1	2.0000	300.0000	2.0000	1	456	
CWEDGE	13	5	113	105	57	114	106	58
CWEDGE	63	5	114	106	58	115	107	59
CWEDGE	113	5	115	107	59	116	108	60
CWEDGE	163	5	116	108	60	117	109	61

## NSWC/WOL TR 77-85

CWEDGE	213	5	117	109	61	118	110	62
CWEDGE	263	5	118	110	62	119	111	63
CWEDGE	313	5	119	111	63	120	112	64
CWEDGE	363	5	120	112	64	113	105	57
CWEDGE	14	5	57	65	113	58	66	114
CWEDGE	64	5	58	66	114	59	67	115
CWEDGE	114	5	59	67	115	60	68	116
CWEDGE	164	5	60	68	116	61	69	117
CWEDGE	214	5	61	69	117	62	70	118
CWEDGE	264	5	62	70	118	63	71	119
CWEDGE	314	5	63	71	119	64	72	120
CWEDGE	364	5	64	72	120	57	65	113
GRID	121	1	2.0000	0.0000	3.0000	1	456	
GRID	122	1	2.0000	30.0000	3.0000	1	456	
GRID	123	1	2.0000	60.0000	3.0000	1	456	
GRID	124	1	2.0000	90.0000	3.0000	1	456	
GRID	125	1	2.0000	135.0000	3.0000	1	456	
GRID	126	1	2.0000	180.0000	3.0000	1	456	
GRID	127	1	2.0000	240.0000	3.0000	1	456	
GRID	128	1	2.0000	300.0000	3.0000	1	456	
CWEDGE	15	5	121	113	65	122	114	66
CWEDGE	65	5	122	114	66	123	115	67
CWEDGE	115	5	123	115	67	124	116	68
CWEDGE	165	5	124	116	68	125	117	69
CWEDGE	215	5	125	117	69	126	118	70
CWEDGE	265	5	126	118	70	127	119	71
CWEDGE	315	5	127	119	71	128	120	72
CWEDGE	365	5	128	120	72	121	113	65
CWEDGE	16	5	65	73	121	66	74	122
CWEDGE	66	5	66	74	122	67	75	123
CWEDGE	116	5	67	75	123	68	76	124
CWEDGE	166	5	68	76	124	69	77	125
CWEDGE	216	5	69	77	125	70	78	126
CWEDGE	266	5	70	78	126	71	79	127
CWEDGE	316	5	71	79	127	72	80	128
CWEDGE	366	5	72	80	128	65	73	121
GRID	129	1	2.0000	0.0000	4.0000	1	456	
GRID	130	1	2.0000	30.0000	4.0000	1	456	
GRID	131	1	2.0000	60.0000	4.0000	1	456	
GRID	132	1	2.0000	90.0000	4.0000	1	456	
GRID	133	1	2.0000	135.0000	4.0000	1	456	
GRID	134	1	2.0000	180.0000	4.0000	1	456	
GRID	135	1	2.0000	240.0000	4.0000	1	456	
GRID	136	1	2.0000	300.0000	4.0000	1	456	
CWEDGE	17	5	129	121	73	130	122	74
CWEDGE	67	5	130	122	74	131	123	75
CWEDGE	117	5	131	123	75	132	124	76
CWEDGE	167	5	132	124	76	133	125	77
CWEDGE	217	5	133	125	77	134	126	78
CWEDGE	267	5	134	126	78	135	127	79
CWEDGE	317	5	135	127	79	136	128	80
CWEDGE	367	5	136	128	80	129	121	73
CWEDGE	18	5	73	81	129	74	82	130
CWEDGE	68	5	74	82	130	75	83	131
CWEDGE	118	5	75	83	131	76	84	132
CWEDGE	168	5	76	84	132	77	85	133
CWEDGE	218	5	77	85	133	78	86	134
CWEDGE	268	5	78	86	134	79	87	135
CWEDGE	318	5	79	87	135	80	88	136
CWEDGE	368	5	80	88	136	73	81	129
GRID	137	1	2.0000	0.0000	5.0000	1	456	
GRID	138	1	2.0000	30.0000	5.0000	1	456	
GRID	139	1	2.0000	60.0000	5.0000	1	456	
GRID	140	1	2.0000	90.0000	5.0000	1	456	

NSWC/WOL TR 77-85

GRID	141	1	2.0000	135.0000	5.0000	1	456	
GRID	142	1	2.0000	180.0000	5.0000	1	456	
GRID	143	1	2.0000	240.0000	5.0000	1	456	
GRID	144	1	2.0000	300.0000	5.0000	1	456	
CWEDGE	19	5	137	129	81	138	130	82
CWEDGE	69	5	138	130	82	139	131	83
CWEDGE	119	5	139	131	83	140	132	84
CWEDGE	169	5	140	132	84	141	133	85
CWEDGE	219	5	141	133	85	142	134	86
CWEDGE	269	5	142	134	86	143	135	87
CWEDGE	319	5	143	135	87	144	136	88
CWEDGE	369	5	144	136	88	137	129	81
CWEDGE	20	5	81	89	137	82	90	138
CWEDGE	70	5	82	90	138	83	91	139
CWEDGE	120	5	83	91	139	84	92	140
CWEDGE	170	5	84	92	140	85	93	141
CWEDGE	220	5	85	93	141	86	94	142
CWEDGE	270	5	86	94	142	87	95	143
CWEDGE	320	5	87	95	143	88	96	144
CWEDGE	370	5	88	96	144	81	89	137
GRID	145	1	2.2500	0.0000	0.0000	1	456	
GRID	146	1	2.2500	30.0000	0.0000	1	456	
GRID	147	1	2.2500	60.0000	0.0000	1	456	
GRID	148	1	2.2500	90.0000	0.0000	1	456	
GRID	149	1	2.2500	135.0000	0.0000	1	456	
GRID	150	1	2.2500	180.0000	0.0000	1	456	
GRID	151	1	2.2500	240.0000	0.0000	1	456	
GRID	152	1	2.2500	300.0000	0.0000	1	456	
GRID	153	1	2.3000	0.0000	1.0000	1	456	
GRID	154	1	2.3000	30.0000	1.0000	1	456	
GRID	155	1	2.3000	60.0000	1.0000	1	456	
GRID	156	1	2.3000	90.0000	1.0000	1	456	
GRID	157	1	2.3000	135.0000	1.0000	1	456	
GRID	158	1	2.3000	180.0000	1.0000	1	456	
GRID	159	1	2.3000	240.0000	1.0000	1	456	
GRID	160	1	2.3000	300.0000	1.0000	1	456	
CWEDGE	21	5	153	145	97	154	146	98
CWEDGE	71	5	154	146	98	155	147	99
CWEDGE	121	5	155	147	99	156	148	100
CWEDGE	171	5	156	148	100	157	149	101
CWEDGE	221	5	157	149	101	158	150	102
CWEDGE	271	5	158	150	102	159	151	103
CWEDGE	321	5	159	151	103	160	152	104
CWEDGE	371	5	160	152	104	153	145	97
CWEDGE	22	5	97	105	153	98	106	154
CWEDGE	72	5	98	106	154	99	107	155
CWEDGE	122	5	99	107	155	100	108	156
CWEDGE	172	5	100	108	156	101	109	157
CWEDGE	222	5	101	109	157	102	110	158
CWEDGE	272	5	102	110	158	103	111	159
CWEDGE	322	5	103	111	159	104	112	160
CWEDGE	372	5	104	112	160	97	105	153
GRID	161	1	2.3500	0.0000	2.0000	1	456	
GRID	162	1	2.3500	30.0000	2.0000	1	456	
GRID	163	1	2.3500	60.0000	2.0000	1	456	
GRID	164	1	2.3500	90.0000	2.0000	1	456	
GRID	165	1	2.3500	135.0000	2.0000	1	456	
GRID	166	1	2.3500	180.0000	2.0000	1	456	
GRID	167	1	2.3500	240.0000	2.0000	1	456	
GRID	168	1	2.3500	300.0000	2.0000	1	456	
CWEDGE	23	5	161	153	105	162	154	106
CWEDGE	73	5	162	154	106	163	155	107
CWEDGE	123	5	163	155	107	164	156	108
CWEDGE	173	5	164	156	108	165	157	109

## NSWC/WOL TR 77-85

CWEDGE	223	5	165	157	109	166	158	110
CWEDGE	273	5	166	158	110	167	159	111
CWEDGE	323	5	167	159	111	168	160	112
CWEDGE	373	5	168	160	112	161	153	105
CWEDGE	24	5	105	113	161	106	114	162
CWEDGE	74	5	106	114	162	107	115	163
CWEDGE	124	5	107	115	163	108	116	164
CWEDGE	174	5	108	116	164	109	117	165
CWEDGE	224	5	109	117	165	110	118	166
CWEDGE	274	5	110	118	166	111	119	167
CWEDGE	324	5	111	119	167	112	120	168
CWEDGE	374	5	112	120	168	105	113	161
GRID	169	1	2.4000	0.0000	3.0000	1	456	
GRID	170	1	2.4000	30.0000	3.0000	1	456	
GRID	171	1	2.4000	60.0000	3.0000	1	456	
GRID	172	1	2.4000	90.0000	3.0000	1	456	
GRID	173	1	2.4000	135.0000	3.0000	1	456	
GRID	174	1	2.4000	180.0000	3.0000	1	456	
GRID	175	1	2.4000	240.0000	3.0000	1	456	
GRID	176	1	2.4000	300.0000	3.0000	1	456	
CWEDGE	25	5	169	161	113	170	162	114
CWEDGE	75	5	170	162	114	171	163	115
CWEDGE	125	5	171	163	115	172	164	116
CWEDGE	175	5	172	164	116	173	165	117
CWEDGE	225	5	173	165	117	174	166	118
CWEDGE	275	5	174	166	118	175	167	119
CWEDGE	325	5	175	167	119	176	168	120
CWEDGE	375	5	176	168	120	169	161	113
CWEDGE	26	5	113	121	169	114	122	170
CWEDGE	76	5	114	122	170	115	123	171
CWEDGE	126	5	115	123	171	116	124	172
CWEDGE	176	5	116	124	172	117	125	173
CWEDGE	226	5	117	125	173	118	126	174
CWEDGE	276	5	118	126	174	119	127	175
CWEDGE	326	5	119	127	175	120	128	176
CWEDGE	376	5	120	128	176	113	121	169
GRID	177	1	2.4500	0.0000	4.0000	1	456	
GRID	178	1	2.4500	30.0000	4.0000	1	456	
GRID	179	1	2.4500	60.0000	4.0000	1	456	
GRID	180	1	2.4500	90.0000	4.0000	1	456	
GRID	181	1	2.4500	135.0000	4.0000	1	456	
GRID	182	1	2.4500	180.0000	4.0000	1	456	
GRID	183	1	2.4500	240.0000	4.0000	1	456	
GRID	184	1	2.4500	300.0000	4.0000	1	456	
CWEDGE	27	5	177	169	121	178	170	122
CWEDGE	77	5	178	170	122	179	171	123
CWEDGE	127	5	179	171	123	180	172	124
CWEDGE	177	5	180	172	124	181	173	125
CWEDGE	227	5	181	173	125	182	174	126
CWEDGE	277	5	182	174	126	183	175	127
CWEDGE	327	5	183	175	127	184	176	128
CWEDGE	377	5	184	176	128	177	169	121
CWEDGE	28	5	121	129	177	122	130	178
CWEDGE	78	5	122	130	178	123	131	179
CWEDGE	128	5	123	131	179	124	132	180
CWEDGE	178	5	124	132	180	125	133	181
CWEDGE	228	5	125	133	181	126	134	182
CWEDGE	278	5	126	134	182	127	135	183
CWEDGE	328	5	127	135	183	128	136	184
CWEDGE	378	5	128	136	184	121	129	177
GRID	185	1	2.5000	0.0000	5.0000	1	456	
GRID	186	1	2.5000	30.0000	5.0000	1	456	
GRID	187	1	2.5000	60.0000	5.0000	1	456	
GRID	188	1	2.5000	90.0000	5.0000	1	456	

NSWC/WOL TR 77-85

GRID	189	1	2.5000	135.0000	5.0000	1	456	
GRID	190	1	2.5000	180.0000	5.0000	1	456	
GRID	191	1	2.5000	240.0000	5.0000	1	456	
GRID	192	1	2.5000	300.0000	5.0000	1	456	
CWEDGE	23	5	185	177	129	186	178	130
CWEDGE	79	5	186	178	130	187	179	131
CWEDGE	129	5	187	179	131	188	180	132
CWEDGE	179	5	188	180	132	189	181	133
CWEDGE	229	5	189	181	133	190	182	134
CWEDGE	279	5	190	182	134	191	183	135
CWEDGE	329	5	191	183	135	192	184	136
CWEDGE	379	5	192	184	136	185	177	129
CWEDGE	30	5	129	137	185	130	138	186
CWEDGE	80	5	130	138	186	131	139	187
CWEDGE	130	5	131	139	187	132	140	188
CWEDGE	180	5	132	140	188	133	141	189
CWEDGE	230	5	133	141	189	134	142	190
CWEDGE	280	5	134	142	190	135	143	191
CWEDGE	330	5	135	143	191	136	144	192
CWEDGE	380	5	136	144	192	129	137	185
GRID	193	1	2.5000	0.0000	0.0000	1	456	
GRID	194	1	2.5000	30.0000	0.0000	1	456	
GRID	195	1	2.5000	60.0000	0.0000	1	456	
GRID	196	1	2.5000	90.0000	0.0000	1	456	
GRID	197	1	2.5000	135.0000	0.0000	1	456	
GRID	198	1	2.5000	180.0000	0.0000	1	456	
GRID	199	1	2.5000	240.0000	0.0000	1	456	
GRID	200	1	2.5000	300.0000	0.0000	1	456	
GRID	201	1	2.6000	0.0000	1.0000	1	456	
GRID	202	1	2.6000	30.0000	1.0000	1	456	
GRID	203	1	2.6000	60.0000	1.0000	1	456	
GRID	204	1	2.6000	90.0000	1.0000	1	456	
GRID	205	1	2.6000	135.0000	1.0000	1	456	
GRID	206	1	2.6000	180.0000	1.0000	1	456	
GRID	207	1	2.6000	240.0000	1.0000	1	456	
GRID	208	1	2.6000	300.0000	1.0000	1	456	
CWEDGE	31	5	201	193	145	202	194	146
CWEDGE	81	5	202	194	146	203	195	147
CWEDGE	131	5	203	195	147	204	196	148
CWEDGE	181	5	204	196	148	205	197	149
CWEDGE	231	5	205	197	149	206	198	150
CWEDGE	281	5	206	198	150	207	199	151
CWEDGE	331	5	207	199	151	208	200	152
CWEDGE	381	5	208	200	152	201	193	145
CWEDGE	32	5	145	153	201	146	154	202
CWEDGE	82	5	146	154	202	147	155	203
CWEDGE	132	5	147	155	203	148	156	204
CWEDGE	182	5	148	156	204	149	157	205
CWEDGE	232	5	149	157	205	150	158	206
CWEDGE	282	5	150	158	206	151	159	207
CWEDGE	332	5	151	159	207	152	160	208
CWEDGE	382	5	152	160	208	145	153	201
GRID	209	1	2.7000	0.0000	2.0000	1	456	
GRID	210	1	2.7000	30.0000	2.0000	1	456	
GRID	211	1	2.7000	60.0000	2.0000	1	456	
GRID	212	1	2.7000	90.0000	2.0000	1	456	
GRID	213	1	2.7000	135.0000	2.0000	1	456	
GRID	214	1	2.7000	180.0000	2.0000	1	456	
GRID	215	1	2.7000	240.0000	2.0000	1	456	
GRID	216	1	2.7000	300.0000	2.0000	1	456	
CWEDGE	33	5	209	201	153	210	202	154
CWEDGE	83	5	210	202	154	211	203	155
CWEDGE	133	5	211	203	155	212	204	156
CWEDGE	183	5	212	204	156	213	205	157

NSWC/WOL TR 77-85

CWEDGE	233	5	213	205	157	214	206	158
CWEDGE	283	5	214	206	158	215	207	159
CWEDGE	333	5	215	207	159	216	208	160
CWEDGE	383	5	216	208	160	209	201	153
CWEDGE	34	5	153	161	209	154	162	210
CWEDGE	84	5	154	162	210	155	163	211
CWEDGE	134	5	155	163	211	156	164	212
CWEDGE	184	5	156	164	212	157	165	213
CWEDGE	234	5	157	165	213	158	166	214
CWEDGE	284	5	158	166	214	159	167	215
CWEDGE	334	5	159	167	215	160	168	216
CWEDGE	384	5	160	168	216	153	161	209
GRID	217	1	2.8000	0.0000	3.0000	1	456	
GRID	218	1	2.8000	30.0000	3.0000	1	456	
GRID	219	1	2.8000	60.0000	3.0000	1	456	
GRID	220	1	2.8000	90.0000	3.0000	1	456	
GRID	221	1	2.8000	135.0000	3.0000	1	456	
GRID	222	1	2.8000	180.0000	3.0000	1	456	
GRID	223	1	2.8000	240.0000	3.0000	1	456	
GRID	224	1	2.8000	300.0000	3.0000	1	456	
CWEDGE	35	5	217	209	161	218	210	162
CWEDGE	85	5	218	210	162	219	211	163
CWEDGE	135	5	219	211	163	220	212	164
CWEDGE	185	5	220	212	164	221	213	165
CWEDGE	235	5	221	213	165	222	214	166
CWEDGE	285	5	222	214	166	223	215	167
CWEDGE	335	5	223	215	167	224	216	168
CWEDGE	385	5	224	216	168	217	209	161
CWEDGE	36	5	161	169	217	162	170	218
CWEDGE	86	5	162	170	218	163	171	219
CWEDGE	136	5	163	171	219	164	172	220
CWEDGE	186	5	164	172	220	165	173	221
CWEDGE	236	5	165	173	221	166	174	222
CWEDGE	286	5	166	174	222	167	175	223
CWEDGE	336	5	167	175	223	168	176	224
CWEDGE	386	5	168	176	224	161	169	217
GRID	225	1	2.9000	0.0000	4.0000	1	456	
GRID	226	1	2.9000	30.0000	4.0000	1	456	
GRID	227	1	2.9000	60.0000	4.0000	1	456	
GRID	228	1	2.9000	90.0000	4.0000	1	456	
GRID	229	1	2.9000	135.0000	4.0000	1	456	
GRID	230	1	2.9000	180.0000	4.0000	1	456	
GRID	231	1	2.9000	240.0000	4.0000	1	456	
GRID	232	1	2.9000	300.0000	4.0000	1	456	
CWEDGE	37	5	225	217	169	226	218	170
CWEDGE	87	5	226	218	170	227	219	171
CWEDGE	137	5	227	219	171	228	220	172
CWEDGE	187	5	228	220	172	229	221	173
CWEDGE	237	5	229	221	173	230	222	174
CWEDGE	287	5	230	222	174	231	223	175
CWEDGE	337	5	231	223	175	232	224	176
CWEDGE	387	5	232	224	176	225	217	169
CWEDGE	38	5	169	177	225	170	178	226
CWEDGE	88	5	170	178	226	171	179	227
CWEDGE	138	5	171	179	227	172	180	228
CWEDGE	188	5	172	180	228	173	181	229
CWEDGE	238	5	173	181	229	174	182	230
CWEDGE	288	5	174	182	230	175	183	231
CWEDGE	338	5	175	183	231	176	184	232
CWEDGE	388	5	176	184	232	169	177	225
GRID	233	1	3.0000	0.0000	5.0000	1	456	
GRID	234	1	3.0000	30.0000	5.0000	1	456	
GRID	235	1	3.0000	60.0000	5.0000	1	456	
GRID	236	1	3.0000	90.0000	5.0000	1	456	

NSWC/WOL TR 77-85

GRID	237	1	3.0000135.0000	5.0000	1	456	
GRID	238	1	3.0000180.0000	5.0000	1	456	
GRID	239	1	3.0000240.0000	5.0000	1	456	
GRID	240	1	3.0000300.0000	5.0000	1	456	
CWEDGE	39	5	233	225	177	234	226 178
CWEDGE	89	5	234	226	178	235	227 179
CWEDGE	139	5	235	227	179	236	228 180
CWEDGE	189	5	236	228	180	237	229 181
CWEDGE	239	5	237	229	181	238	230 182
CWEDGE	289	5	238	230	182	239	231 183
CWEDGE	339	5	239	231	183	240	232 184
CWEDGE	389	5	240	232	184	233	225 177
CWEDGE	40	5	177	185	233	178	186 234
CWEDGE	90	5	178	186	234	179	187 235
CWEDGE	140	5	179	187	235	180	188 236
CWEDGE	190	5	180	188	236	181	189 237
CWEDGE	240	5	181	189	237	182	190 238
CWEDGE	290	5	182	190	238	183	191 239
CWEDGE	340	5	183	191	239	184	192 240
CWEDGE	390	5	184	192	240	177	185 233

## PROBLEM B-V

## PRESCRIBED POINTS AND LINES

The following problem demonstrates the application of prescribed points and lines in a solid ring. Figure B-36 shows the planned finite element model and configuration of a solid ring containing both fixed lines and points. Three options are available to the user. The first picking both grid point number and grid coordinate, the second using the program calculated grid coordinate and pinching the grid number, and the third pinching the grid coordinate and using the program calculated grid number. The added feature of having either increasing or decreasing prescribed grid numbers (for lines only) is also included.

A complete listing of the data input is shown in Figure B-37. Figure B-38 shows the grid point and element numbers as generated by JIG. Figure B-39 gives a NASTRAN structural plot and is followed by a listing of the JIG punched output.

SAMPLE 5

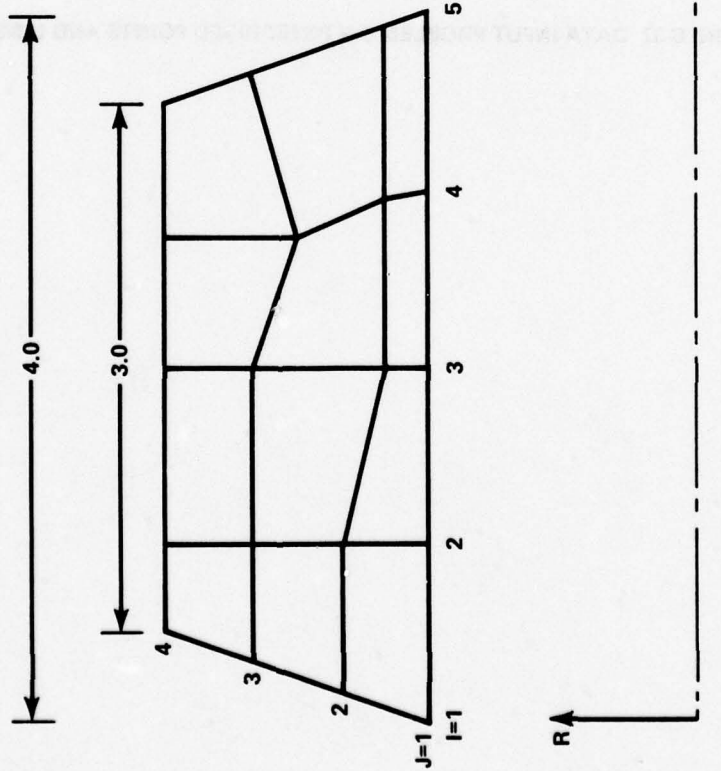

FIXED COORDINATES

I <sub>1</sub>	J <sub>1</sub>	Z <sub>1</sub>	X <sub>1</sub>	I <sub>2</sub>	J <sub>2</sub>	Z <sub>2</sub>	X <sub>2</sub>
3	2	2.00	1.75	5	2	3.9167	1.75
2	1	1.00	1.50	2	4	1.0000	3.00
4	3	2.75	2.25	-	-	-	-

FIXED GRID NO.'S

(1, 1) → (4, 1)	#200 - 203
(2, 3)	#300

FIG. B-36 PLANNED FINITE ELEMENT MODEL AND CONFIGURATION OF A SOLID RING CONTAINING BOTH FIXED LINES AND POINTS.

\*\*\* SAMPLE 5 - FIXED POINTS AND LINES \*\*\*

1	1	1	1	50	0	0	1					
0.0												
4	1	4	1	5	5	0	0	0	0	456	0	
1	1	0.0		1.5		1	5	1	4.0		1.5	1
5	4	3.5		3.0		1	1	4	0.5		3.0	1
2	2	1	2	1								
3	2	2.0		1.75		0	1	5	2	3.9167	1.75	
2	1	1.0		1.5		0	1	2	4	1.0	3.0	
4	3	2.75		2.25		0	1					
1	1	0.0		-1.0		200	1	4	1	0.0	0.0	
2	3	0.0		-1.0		300	1					

FIG. B-37 DATA INPUT PROBLEM B-V PRESCRIBED POINTS AND LINES.

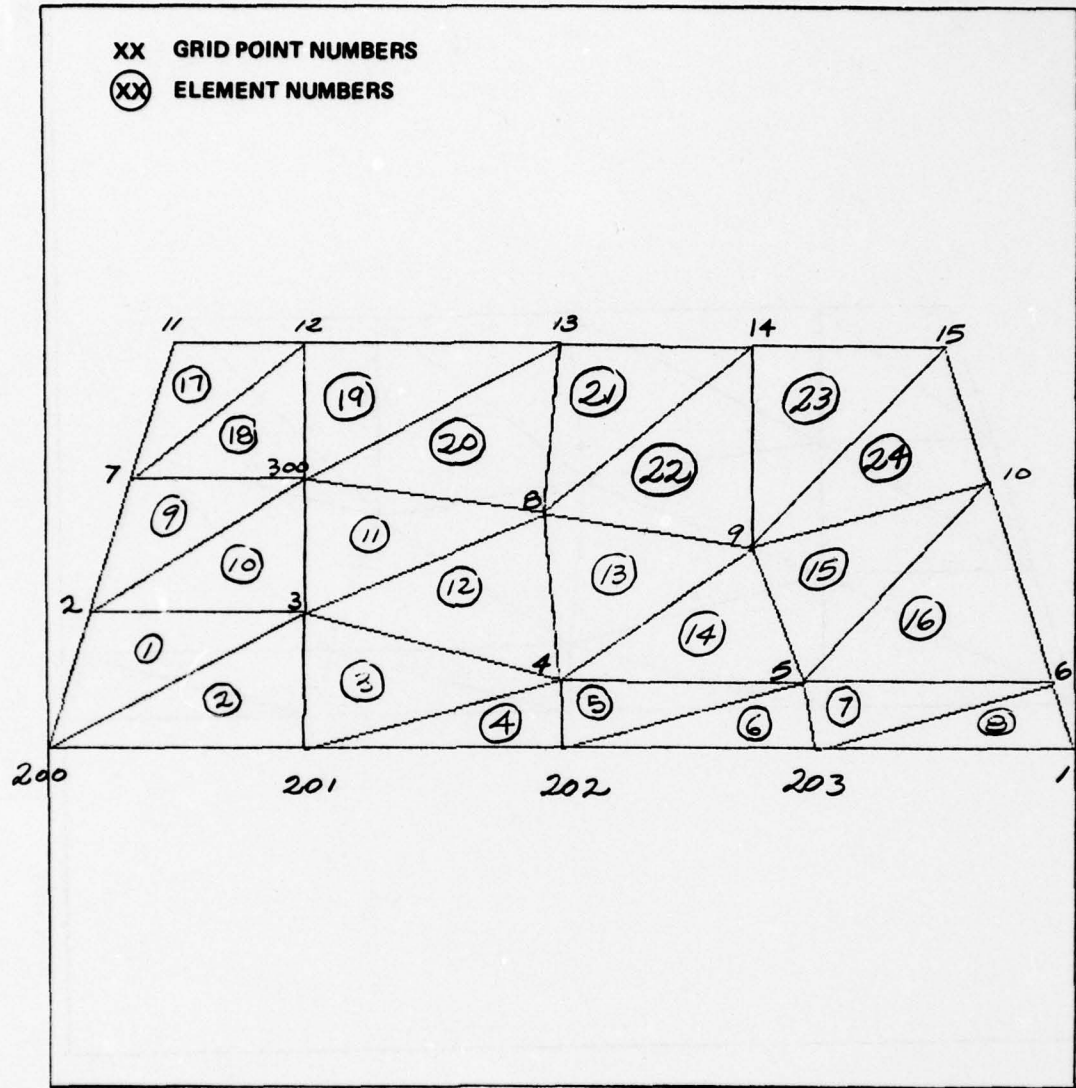

FIG. B-38 GRID POINT AND ELEMENT NUMBERS

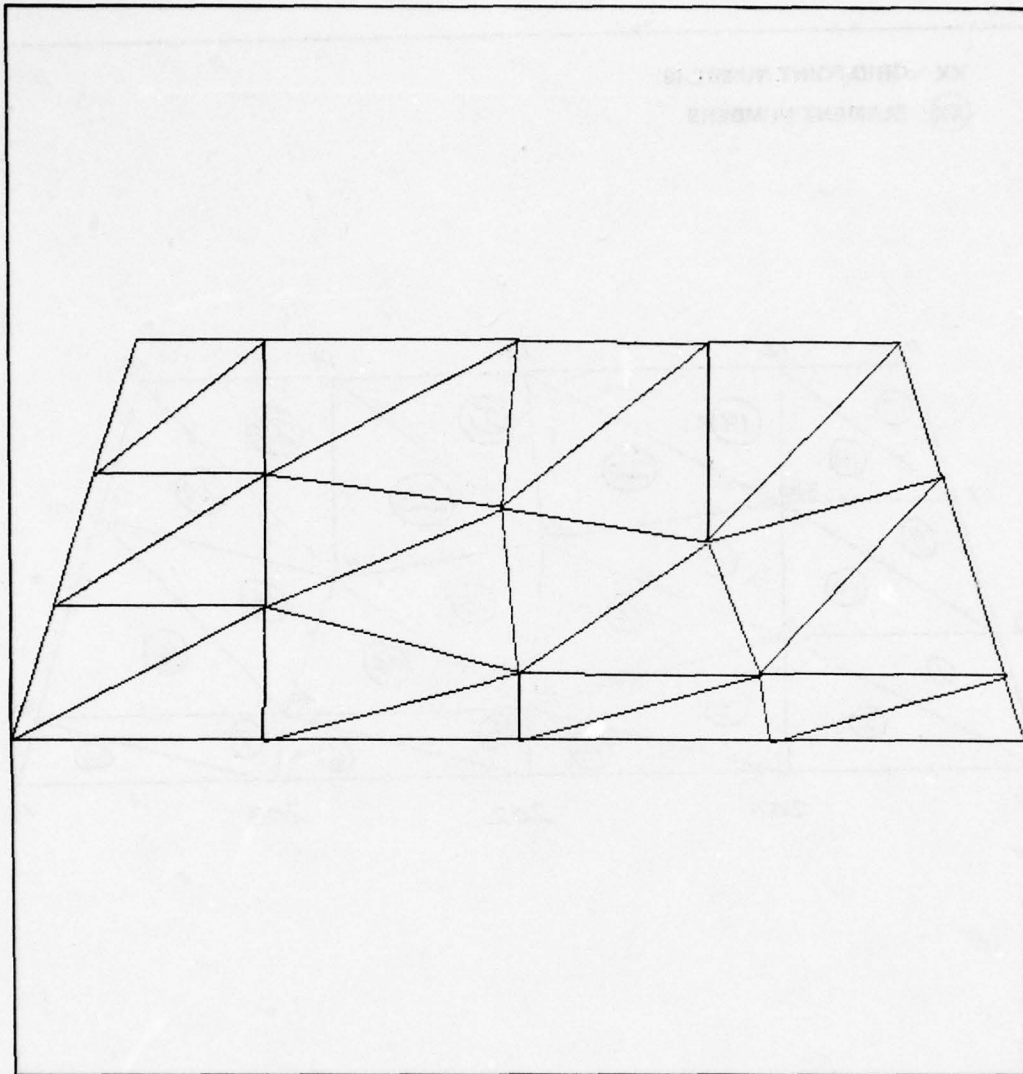

FIG. B-39 NASTRAN STRUCTURAL PLOT

LISTING OF PUNCHED NASTRAN BULK DATA CARDS  
PROBLEM B-V PRESCRIBED POINTS AND LINES

```
*****  
*****  
** JUNCTION INPUT GENERATOR PROGRAM (JIG) **  
**  
*****  
*****
```

\*\*\* SAMPLE 5 - FIXED POINTS AND LINES \*\*\*

```
NST = 1  
NGS = 1  
NES = 1  
NPOP = 1  
MID = 50  
NGP = 0  
IDELT = 0  
NSECT = 1  
NT( 1) = 1      DELTZ( 1) = 0.0000
```

NSWC/WOL TR 77-85

I	J	Z(I,J)	X(I,J)	CODE(I,J)			
1	1	0.00000	1.50000	1			
2	1	1.00000	1.50000	1			
3	1	2.00000	1.50000	1			
4	1	3.00000	1.50000	1			
5	1	4.00000	1.50000	1			
1	2	.16667	2.00000	1			
2	2	1.00000	2.00000	2			
3	2	2.00000	1.75000	2			
4	2	2.95835	1.75000	2			
5	2	3.91670	1.75000	1			
1	3	.33333	2.50000	1			
2	3	1.00000	2.50000	2			
3	3	1.93751	2.37502	0			
4	3	2.75000	2.25000	2			
5	3	3.66667	2.50000	1			
1	4	.50000	3.00000	1			
2	4	1.00000	3.00000	1			
3	4	2.00000	3.00000	1			
4	4	2.75000	3.00000	1			
5	4	3.50000	3.00000	1			
GRID	200	0	1.5000	0.0000	0.0000	0	456
GRID	201	0	1.5000	0.0000	1.0000	0	456
GRID	202	0	1.5000	0.0000	2.0000	0	456
GRID	203	0	1.5000	0.0000	3.0000	0	456
GRID	1	0	1.5000	0.0000	4.0000	0	456
GRID	2	0	2.0000	0.0000	.1667	0	456
GRID	3	0	2.0000	0.0000	1.0000	0	456
CTRIARG	1	3	2	200	0.0000	50	
CTRIARG	2	200	201	3	0.0000	50	
GRID	4	0	1.7500	0.0000	2.0000	0	456
CTRIARG	3	4	3	201	0.0000	50	
CTRIARG	4	201	202	4	0.0000	50	
GRID	5	0	1.7500	0.0000	2.9584	0	456
CTRIARG	5	5	4	202	0.0000	50	
CTRIARG	6	202	203	5	0.0000	50	
GRID	6	0	1.7500	0.0000	3.9167	0	456
CTRIARG	7	6	5	203	0.0000	50	
CTRIARG	8	203	1	6	0.0000	50	
GRID	7	0	2.5000	0.0000	.3333	0	456
GRID	300	0	2.5000	0.0000	1.0000	0	456
CTRIARG	9	300	7	2	0.0000	50	
CTRIARG	10	2	3	300	0.0000	50	
GRID	8	0	2.3750	0.0000	1.9375	0	456
CTRIARG	11	8	300	3	0.0000	50	
CTRIARG	12	3	4	8	0.0000	50	
GRID	9	0	2.2500	0.0000	2.7500	0	456
CTRIARG	13	9	8	4	0.0000	50	
CTRIARG	14	4	5	9	0.0000	50	
GRID	10	0	2.5000	0.0000	3.6667	0	456
CTRIARG	15	10	9	5	0.0000	50	
CTRIARG	16	5	6	10	0.0000	50	
GRID	11	0	3.0000	0.0000	.5000	0	456
GRID	12	0	3.0000	0.0000	1.0000	0	456
CTRIARG	17	12	11	7	0.0000	50	
CTRIARG	18	7	300	12	0.0000	50	
GRID	13	0	3.0000	0.0000	2.0000	0	456
CTRIARG	19	13	12	300	0.0000	50	
CTRIARG	20	300	8	13	0.0000	50	

NSWC/WOL TR 77-85

GRID	14	0	3.0000	0.0000	2.7500	0	456
CTRIARG	21	14	13	8	0.0000	50	
CTRIARG	22	8	9	14	0.0000	50	
GRID	15	0	3.0000	0.0000	3.5000	0	456
CTRIARG	23	15	14	9	0.0000	50	
CTRIARG	24	9	10	15	0.0000	50	

## PROBLEM B-VI

## TRANSITION

The following problem demonstrates the JIG transition options for coarse to fine mesh size or vice versa. Figure B-40 shows the planned finite element model and configuration of a solid cylindrical ring containing coarse to fine then back to coarse regions. The NTNT values must be established at the beginning of a section and at the end of each transition region. The value NTNT is set equal to zero for the finest mesh. Then it is increased by one every time the mesh spacing doubles. Note that at no time can the value of NTNT be less than zero ( $NTNT \geq 0$ ).

A complete listing of the data input is shown in Figure B-41. Figure B-42 shows the grid point and element identification numbers as generated by JIG. Figure B-43 gives a NASTRAN structural plot of the finite element model and is followed by a listing of the JIG punched output.

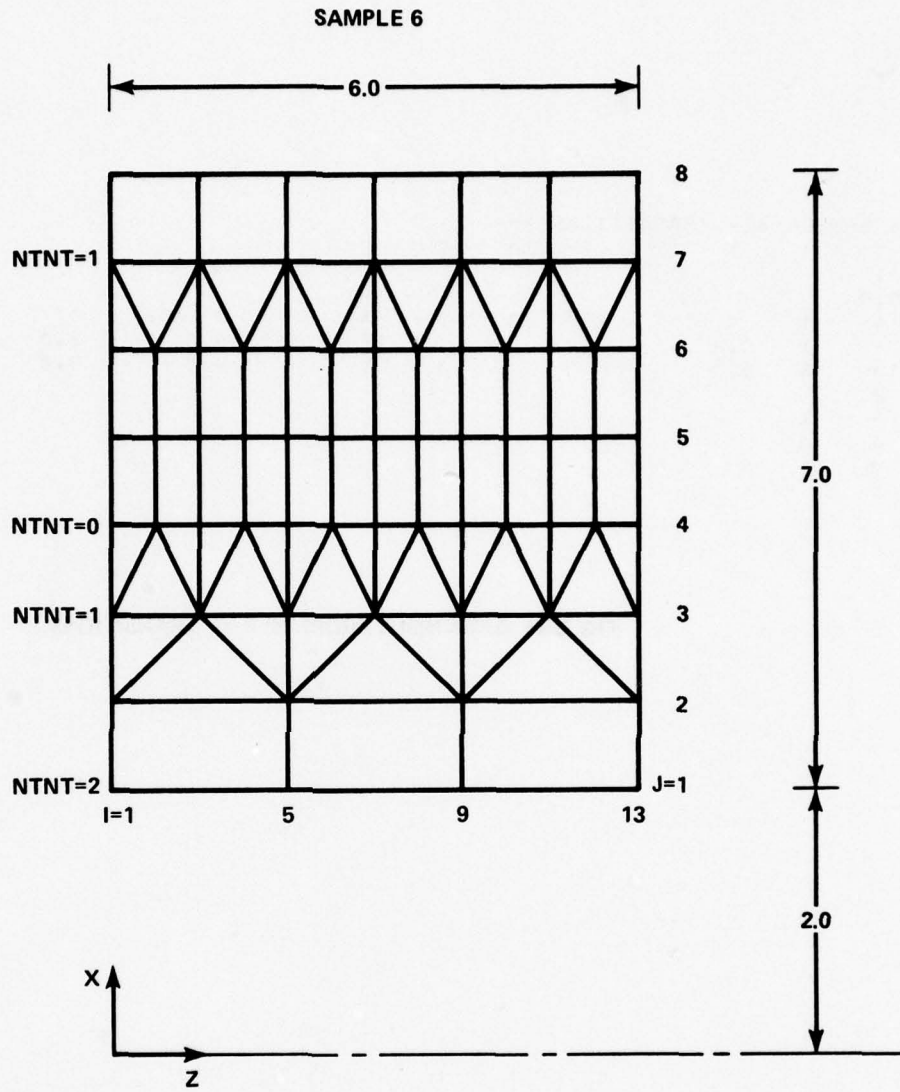

FIG. B-40 PLANNED FINITE ELEMENT MODEL AND CONFIGURATION OF A SOLID CYLINDRICAL RING CONTAINING COARSE TO FINE THEN BACK TO COARSE REGIONS.

\*\*\* SAMPLE 6 - TRANSITIONS \*\*\*

1	1	1	1	7	0	0	1					
1												
0.0												
4	1	8	1	13	0	0	3	0	0	456	0	
1	1	0.0		2.0		1	13	1	6.0		2.0	1
13	8	6.0		9.0		1	1	8	0.0		9.0	1
2												
3	1											
4	0											
7	1											

FIG. B-41 DATA INPUT PROBLEM B-VI TRANSITIONS

XX GRID NUMBERS  
 (XX) ELEMENT NUMBERS

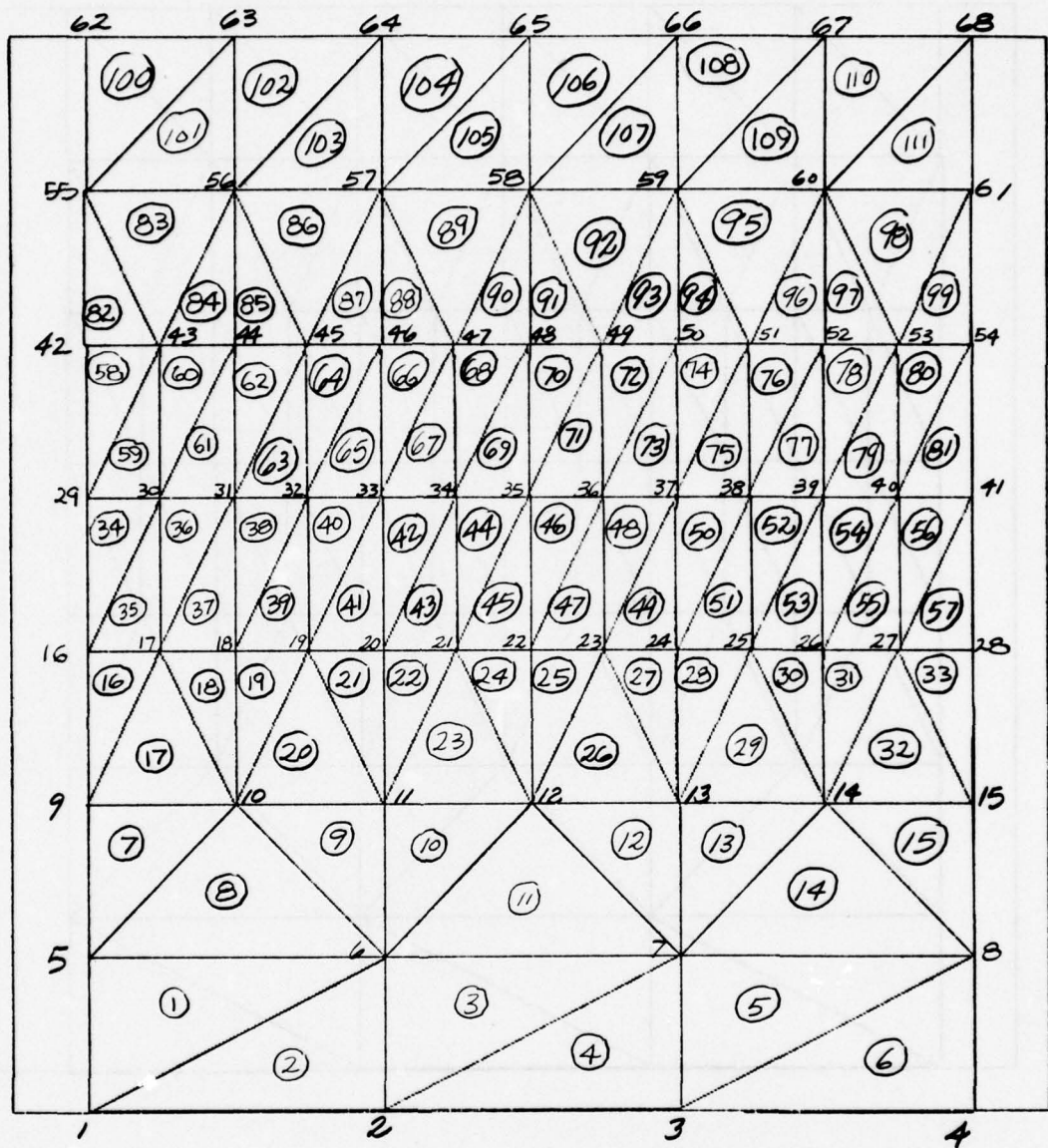

FIG. B-42 GRID POINT AND ELEMENT NUMBERS

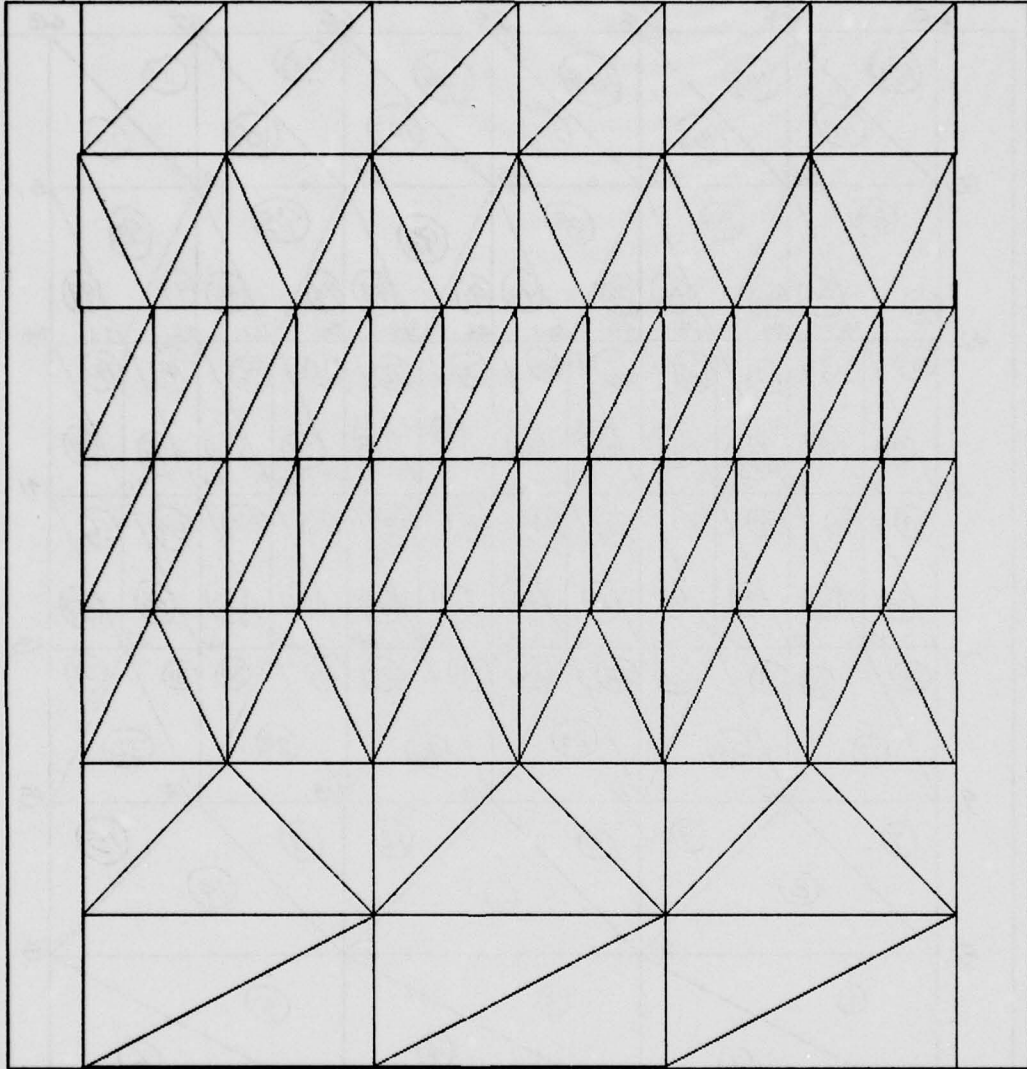

FIG. B-43 NASTRAN STRUCTURAL PLOT

LISTING OF PUNCHED NASTRAN BULK DATA CARDS  
PROBLEM B-VI TRANSITION

```
*****  
*****  
**  
** JUNCTION INPUT GENERATOR PROGRAM (JIG) **  
**  
*****  
*****
```

\*\*\* SAMPLE 6 - TRANSITIONS \*\*\*

```
NST = 1  
NGS = 1  
NES = 1  
NPOP = 1  
MID = 7  
NGP = 0  
IDELT = 0  
NSECT = 1  
NT( 1) = 1      DELTZ( 1) = 0.0000
```

## NSWC/WOL TR 77-85

I	J	Z(I,J)	X(I,J)	CODE(I,J)
1	1	0.00000	2.00000	1
2	1	.50000	2.00000	1
3	1	1.00000	2.00000	1
4	1	1.50000	2.00000	1
5	1	2.00000	2.00000	1
6	1	2.50000	2.00000	1
7	1	3.00000	2.00000	1
8	1	3.50000	2.00000	1
9	1	4.00000	2.00000	1
10	1	4.50000	2.00000	1
11	1	5.00000	2.00000	1
12	1	5.50000	2.00000	1
13	1	6.00000	2.00000	1
1	2	0.00000	3.00000	1
2	2	.49999	3.00001	0
3	2	1.00002	3.00004	0
4	2	1.50002	3.00003	0
5	2	2.00002	3.00001	0
6	2	2.50003	3.00003	0
7	2	3.00002	3.00002	0
8	2	3.50002	3.00001	0
9	2	4.00001	3.00002	0
10	2	4.49997	2.99996	0
11	2	5.00002	3.00002	0
12	2	5.49999	2.99999	0
13	2	6.00000	3.00000	1
1	3	0.00000	4.00000	1
2	3	.50001	4.00004	0
3	3	1.00001	4.00006	0
4	3	1.50001	4.00003	0
5	3	2.00003	4.00002	0
6	3	2.50003	4.00003	0
7	3	3.00001	4.00002	0
8	3	3.50002	4.00003	0
9	3	3.99998	3.99998	0
10	3	4.49999	3.99997	0
11	3	5.00001	4.00001	0
12	3	5.50000	3.99999	0
13	3	6.00000	4.00000	1
1	4	0.00000	5.00000	1
2	4	.50000	5.00004	0
3	4	1.00000	5.00004	0
4	4	1.50001	5.00001	0
5	4	2.00002	5.00002	0
6	4	2.50002	5.00003	0
7	4	3.00003	5.00004	0
8	4	3.50000	5.00000	0
9	4	4.00000	4.99999	0
10	4	4.49998	4.99997	0
11	4	5.00001	5.00000	0
12	4	5.49999	4.99999	0
13	4	6.00000	5.00000	1
1	5	0.00000	6.00000	1
2	5	.49999	6.00002	0
3	5	.99998	5.99998	0
4	5	1.49998	5.99996	0
5	5	2.00000	6.00000	0
6	5	2.50001	6.00002	0

NSWC/WOL TR 77-85

7	5	2.99999	5.99999	0			
8	5	3.49999	5.99997	0			
9	5	3.99998	5.99997	0			
10	5	4.49997	5.99995	0			
11	5	4.99999	5.99999	0			
12	5	5.49999	5.99998	0			
13	5	6.00000	6.00000	1			
1	6	0.00000	7.00000	1			
2	6	.49997	6.99997	0			
3	6	.99996	6.99995	0			
4	6	1.49997	6.99997	0			
5	6	2.00001	7.00002	0			
6	6	2.49999	7.00001	0			
7	6	2.99999	6.99998	0			
8	6	3.49999	6.99999	0			
9	6	3.99998	6.99998	0			
10	6	4.49998	6.99997	0			
11	6	5.00000	7.00001	0			
12	6	5.50001	7.00001	0			
13	6	6.00000	7.00000	1			
1	7	0.00000	8.00000	1			
2	7	.49998	7.99998	0			
3	7	.99998	7.99998	0			
4	7	1.50001	8.00001	0			
5	7	2.00001	8.00002	0			
6	7	2.49999	8.00000	0			
7	7	3.00000	8.00000	0			
8	7	3.50000	8.00000	0			
9	7	4.00000	7.99999	0			
10	7	4.49999	7.99998	0			
11	7	5.00002	8.00002	0			
12	7	5.50000	7.99999	0			
13	7	6.00000	8.00000	1			
1	8	0.00000	9.00000	1			
2	8	.50000	9.00000	1			
3	8	1.00000	9.00000	1			
4	8	1.50000	9.00000	1			
5	8	2.00000	9.00000	1			
6	8	2.50000	9.00000	1			
7	8	3.00000	9.00000	1			
8	8	3.50000	9.00000	1			
9	8	4.00000	9.00000	1			
10	8	4.50000	9.00000	1			
11	8	5.00000	9.00000	1			
12	8	5.50000	9.00000	1			
13	8	6.00000	9.00000	1			
GRID	1	0	2.0000	0.0000	0.0000	0	456
GRID	2	0	2.0000	0.0000	2.0000	0	456
GRID	3	0	2.0000	0.0000	4.0000	0	456
GRID	4	0	2.0000	0.0000	6.0000	0	456
GRID	5	0	3.0000	0.0000	0.0000	0	456
GRID	6	0	3.0000	0.0000	2.0000	0	456
CTRIARG	1	6	5	1	0.0000	7	
CTRIARG	2	1	2	6	0.0000	7	
GRID	7	0	3.0000	0.0000	4.0000	0	456
CTRIARG	3	7	6	2	0.0000	7	
CTRIARG	4	2	3	7	0.0000	7	
GRID	8	0	3.0000	0.0000	6.0000	0	456
CTRIARG	5	8	7	3	0.0000	7	
CTRIARG	6	3	4	8	0.0000	7	
GRID	9	0	4.0000	0.0000	0.0000	0	456
GRID	10	0	4.0001	0.0000	1.0000	0	456
GRID	11	0	4.0000	0.0000	2.0000	0	456
CTRIARG	7	10	9	5	0.0000	7	

NSWC/WOL TR 77-85

CTRIARG	8	5	6	10	0.0000	7	
CTRIARG	9	6	11	10	0.0000	7	
GRID	12	0	4.0000	0.0000	3.0000	0	456
GRID	13	0	4.0000	0.0000	4.0000	0	456
CTRIARG	10	12	11	6	0.0000	7	
CTRIARG	11	6	7	12	0.0000	7	
CTRIARG	12	7	13	12	0.0000	7	
GRID	14	0	4.0000	0.0000	5.0000	0	456
GRID	15	0	4.0000	0.0000	6.0000	0	456
CTRIARG	13	14	13	7	0.0000	7	
CTRIARG	14	7	8	14	0.0000	7	
CTRIARG	15	8	15	14	0.0000	7	
GRID	16	0	5.0000	0.0000	0.0000	0	456
GRID	17	0	5.0000	0.0000	.5000	0	456
GRID	18	0	5.0000	0.0000	1.0000	0	456
CTRIARG	16	17	16	9	0.0000	7	
CTRIARG	17	9	10	17	0.0000	7	
CTRIARG	18	10	18	17	0.0000	7	
GRID	19	0	5.0000	0.0000	1.5000	0	456
GRID	20	0	5.0000	0.0000	2.0000	0	456
CTRIARG	19	19	18	10	0.0000	7	
CTRIARG	20	10	11	19	0.0000	7	
CTRIARG	21	11	20	19	0.0000	7	
GRID	21	0	5.0000	0.0000	2.5000	0	456
GRID	22	0	5.0000	0.0000	3.0000	0	456
CTRIARG	22	21	20	11	0.0000	7	
CTRIARG	23	11	12	21	0.0000	7	
CTRIARG	24	12	22	21	0.0000	7	
GRID	23	0	5.0000	0.0000	3.5000	0	456
GRID	24	0	5.0000	0.0000	4.0000	0	456
CTRIARG	25	23	22	12	0.0000	7	
CTRIARG	26	12	13	23	0.0000	7	
CTRIARG	27	13	24	23	0.0000	7	
GRID	25	0	5.0000	0.0000	4.5000	0	456
GRID	26	0	5.0000	0.0000	5.0000	0	456
CTRIARG	28	25	24	13	0.0000	7	
CTRIARG	29	13	14	25	0.0000	7	
CTRIARG	30	14	26	25	0.0000	7	
GRID	27	0	5.0000	0.0000	5.5000	0	456
GRID	28	0	5.0000	0.0000	6.0000	0	456
CTRIARG	31	27	26	14	0.0000	7	
CTRIARG	32	14	15	27	0.0000	7	
CTRIARG	33	15	28	27	0.0000	7	
GRID	29	0	6.0000	0.0000	0.0000	0	456
GRID	30	0	6.0000	0.0000	.5000	0	456
CTRIARG	34	30	29	16	0.0000	7	
CTRIARG	35	16	17	30	0.0000	7	
GRID	31	0	6.0000	0.0000	1.0000	0	456
CTRIARG	36	31	30	17	0.0000	7	
CTRIARG	37	17	18	31	0.0000	7	
GRID	32	0	6.0000	0.0000	1.5000	0	456
CTRIARG	38	32	31	18	0.0000	7	
CTRIARG	39	18	19	32	0.0000	7	
GRID	33	0	6.0000	0.0000	2.0000	0	456
CTRIARG	40	33	32	19	0.0000	7	
CTRIARG	41	19	20	33	0.0000	7	
GRID	34	0	6.0000	0.0000	2.5000	0	456
CTRIARG	42	34	33	20	0.0000	7	
CTRIARG	43	20	21	34	0.0000	7	
GRID	35	0	6.0000	0.0000	3.0000	0	456
CTRIARG	44	35	34	21	0.0000	7	
CTRIARG	45	21	22	35	0.0000	7	
GRID	36	0	6.0000	0.0000	3.5000	0	456
CTRIARG	46	36	35	22	0.0000	7	

## NSWC/WOL TR 77-85

CTRIARG	47	22	23	36	0.0000	7	
GRID	37	0	6.0000	0.0000	4.0000	0	456
CTRIARG	48	37	36	23	0.0000	7	
CTRIARG	49	23	24	37	0.0000	7	
GRID	38	0	5.9999	0.0000	4.5000	0	456
CTRIARG	50	38	37	24	0.0000	7	
CTRIARG	51	24	25	38	0.0000	7	
GRID	39	0	6.0000	0.0000	5.0000	0	456
CTRIARG	52	39	38	25	0.0000	7	
CTRIARG	53	25	26	39	0.0000	7	
GRID	40	0	6.0000	0.0000	5.5000	0	456
CTRIARG	54	40	39	26	0.0000	7	
CTRIARG	55	26	27	40	0.0000	7	
GRID	41	0	6.0000	0.0000	6.0000	0	456
CTRIARG	56	41	40	27	0.0000	7	
CTRIARG	57	27	28	41	0.0000	7	
GRID	42	0	7.0000	0.0000	0.0000	0	456
GRID	43	0	7.0000	0.0000	.5000	0	456
CTRIARG	58	43	42	29	0.0000	7	
CTRIARG	59	29	30	43	0.0000	7	
GRID	44	0	7.0000	0.0000	1.0000	0	456
CTRIARG	60	44	43	30	0.0000	7	
CTRIARG	61	30	31	44	0.0000	7	
GRID	45	0	7.0000	0.0000	1.5000	0	456
CTRIARG	62	45	44	31	0.0000	7	
CTRIARG	63	31	32	45	0.0000	7	
GRID	46	0	7.0000	0.0000	2.0000	0	456
CTRIARG	64	46	45	32	0.0000	7	
CTRIARG	65	32	33	46	0.0000	7	
GRID	47	0	7.0000	0.0000	2.5000	0	456
CTRIARG	66	47	46	33	0.0000	7	
CTRIARG	67	33	34	47	0.0000	7	
GRID	48	0	7.0000	0.0000	3.0000	0	456
CTRIARG	68	48	47	34	0.0000	7	
CTRIARG	69	34	35	48	0.0000	7	
GRID	49	0	7.0000	0.0000	3.5000	0	456
CTRIARG	70	49	48	35	0.0000	7	
CTRIARG	71	35	36	49	0.0000	7	
GRID	50	0	7.0000	0.0000	4.0000	0	456
CTRIARG	72	50	49	36	0.0000	7	
CTRIARG	73	36	37	50	0.0000	7	
GRID	51	0	7.0000	0.0000	4.5000	0	456
CTRIARG	74	51	50	37	0.0000	7	
CTRIARG	75	37	38	51	0.0000	7	
GRID	52	0	7.0000	0.0000	5.0000	0	456
CTRIARG	76	52	51	38	0.0000	7	
CTRIARG	77	38	39	52	0.0000	7	
GRID	53	0	7.0000	0.0000	5.5000	0	456
CTRIARG	78	53	52	39	0.0000	7	
CTRIARG	79	39	40	53	0.0000	7	
GRID	54	0	7.0000	0.0000	6.0000	0	456
CTRIARG	80	54	53	40	0.0000	7	
CTRIARG	81	40	41	54	0.0000	7	
GRID	55	0	8.0000	0.0000	0.0000	0	456
GRID	56	0	8.0000	0.0000	1.0000	0	456
CTRIARG	82	42	43	55	0.0000	7	
CTRIARG	83	43	56	55	0.0000	7	
CTRIARG	84	43	44	56	0.0000	7	
GRID	57	0	8.0000	0.0000	2.0000	0	456
CTRIARG	85	44	45	56	0.0000	7	
CTRIARG	86	45	57	56	0.0000	7	
CTRIARG	87	45	46	57	0.0000	7	
GRID	58	0	8.0000	0.0000	3.0000	0	456
CTRIARG	88	46	47	57	0.0000	7	

## NSWC/WOL TR 77-85

CTRIARG	89	47	58	57	0.0000	7	
CTRIARG	90	47	48	58	0.0000	7	
GRID	59	0	8.0000	0.0000	4.0000	0	456
CTRIARG	91	48	49	58	0.0000	7	
CTRIARG	92	49	59	58	0.0000	7	
CTRIARG	93	49	50	59	0.0000	7	
GRID	60	0	8.0000	0.0000	5.0000	0	456
CTRIARG	94	50	51	59	0.0000	7	
CTRIARG	95	51	60	59	0.0000	7	
CTRIARG	96	51	52	60	0.0000	7	
GRID	61	0	8.0000	0.0000	6.0000	0	456
CTRIARG	97	52	53	60	0.0000	7	
CTRIARG	98	53	61	60	0.0000	7	
CTRIARG	99	53	54	61	0.0000	7	
GRID	62	0	9.0000	0.0000	0.0000	0	456
GRID	63	0	9.0000	0.0000	1.0000	0	456
CTRIARG	100	63	62	55	0.0000	7	
CTRIARG	101	55	56	63	0.0000	7	
GRID	64	0	9.0000	0.0000	2.0000	0	456
CTRIARG	102	64	63	56	0.0000	7	
CTRIARG	103	56	57	64	0.0000	7	
GRID	65	0	9.0000	0.0000	3.0000	0	456
CTRIARG	104	65	64	57	0.0000	7	
CTRIARG	105	57	58	65	0.0000	7	
GRID	66	0	9.0000	0.0000	4.0000	0	456
CTRIARG	106	66	65	58	0.0000	7	
CTRIARG	107	58	59	66	0.0000	7	
GRID	67	0	9.0000	0.0000	5.0000	0	456
CTRIARG	108	67	66	59	0.0000	7	
CTRIARG	109	59	60	67	0.0000	7	
GRID	68	0	9.0000	0.0000	6.0000	0	456
CTRIARG	110	68	67	60	0.0000	7	
CTRIARG	111	60	61	68	0.0000	7	

PROBLEM B-VII

MPC GENERATOR

The following problem demonstrates the JIG MPC generator. This feature generates the required NASTRAN MPC cards used to connect the solid wedge elements to plate elements. In an actual missile, the joint can be represented by the solid wedge elements and the shell by plate elements. Therefore the wedge elements can have shell elements either forward or aft of the joint or on both sides of the joint. Figure B-44 shows the planned finite element model and configuration of a missile joint. Only one half of the joint was modeled. Similar type of model preparation would be required if one were to model both halves of the joint.

A complete listing of the data input is shown in Figure B-45. Figure B-46 shows the grid point and element identification numbers as generated by JIG. Figures B-47 and B-48 give two views of the NASTRAN structural plots of the finite element model and are followed by a listing of the JIG punched output.

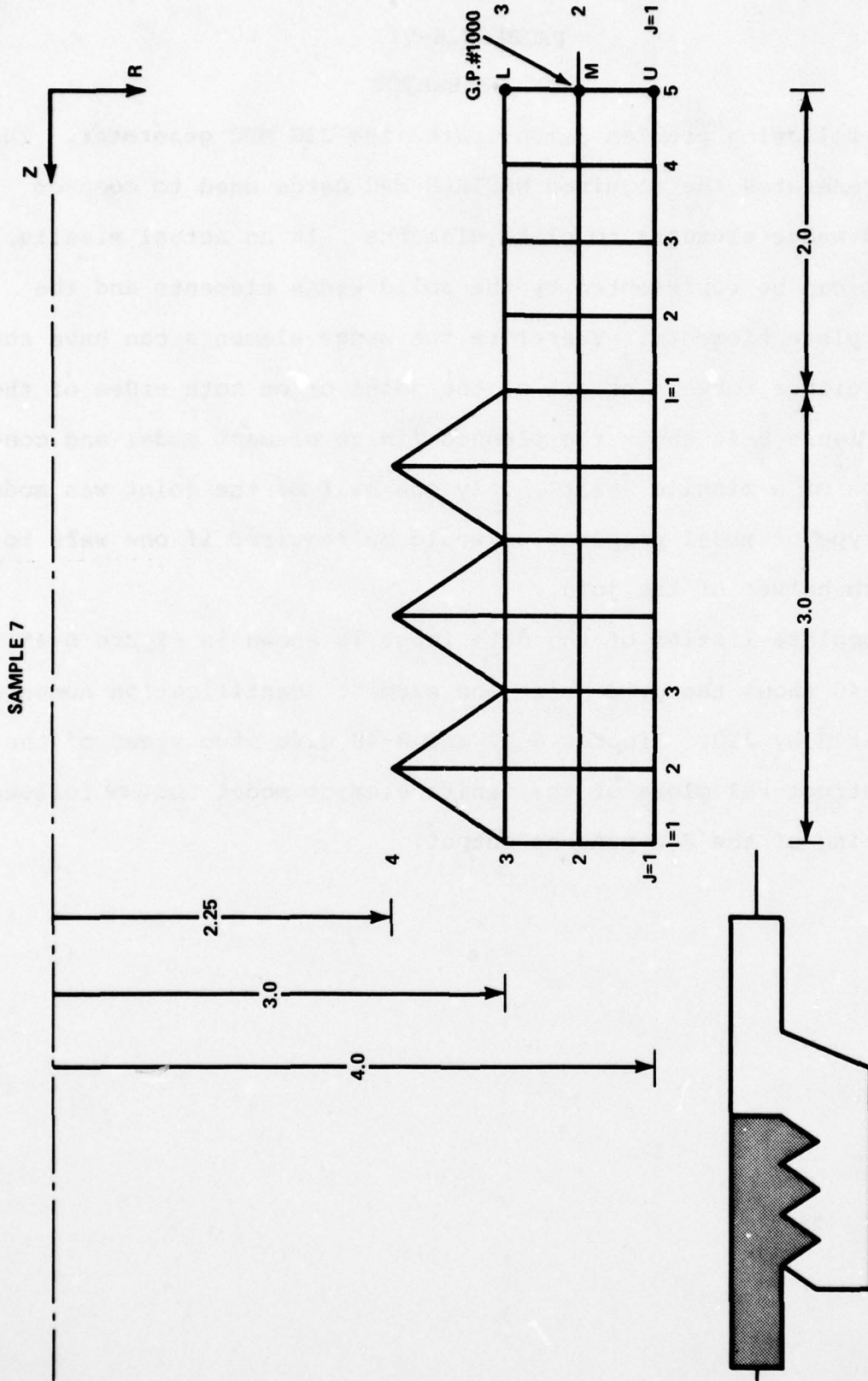

FIG. B-44 PLANNED FINITE ELEMENT MODEL AND CONFIGURATION OF A MISSILE JOINT.

```

*** SAMPLE 7 - JOINT WITH MPC ***
 2  1  1  3  10  0  1  1
 3  1
-1.0      0.0
 1  1  100
 1  0.0      3  90.0
 0.0      90.0
 1  4
 4  1  3  1  3  0  1  0  1  3  456  0
 4  4.5      2.25
 1  1  5.0      4.0      1  3  1  4.0      4.0      1
 3  3  4.0      3.0      1  1  3  5.0      3.0      1
 4  1  3  1  5  1  0  0  1  3  456  1
 1
 5  1  5  2  5  1  5  0
 1  1  2.0      4.0      1  5  1  0.0      4.0      1
 5  3  0.0      3.0      1  1  3  2.0      3.0      1
 1
 5  2  0.0      3.5      1000  1
2456 2456      456 246 246

```

FIG. 3-45 DATA INPUT PROBLEM B-VII MPC GENERATOR

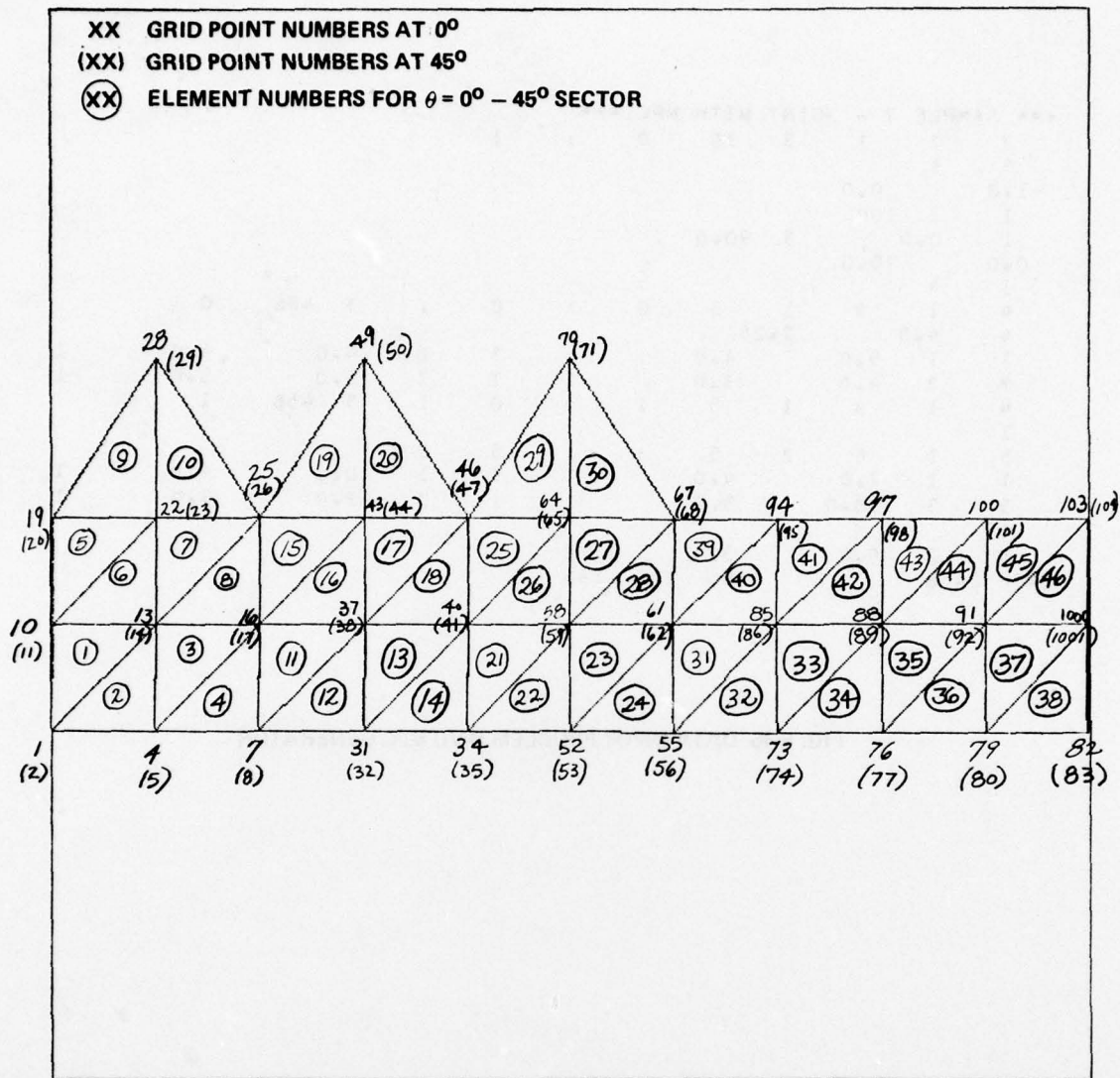

FIG. B-46 GRID POINT AND ELEMENT NUMBERS

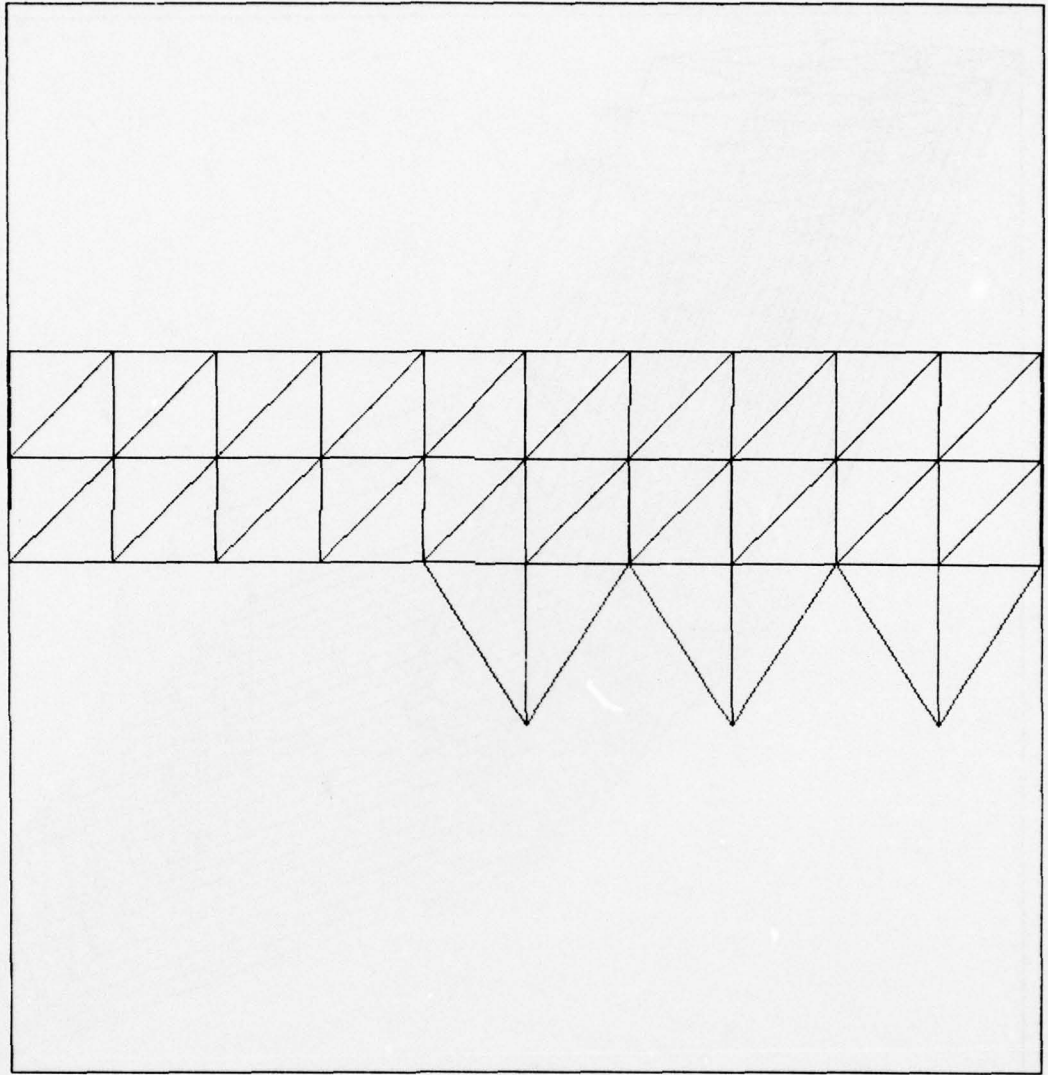

FIG. B-47 NASTRAN STRUCTURAL PLOT SHOWING CROSS SECTIONS OF JOINT.

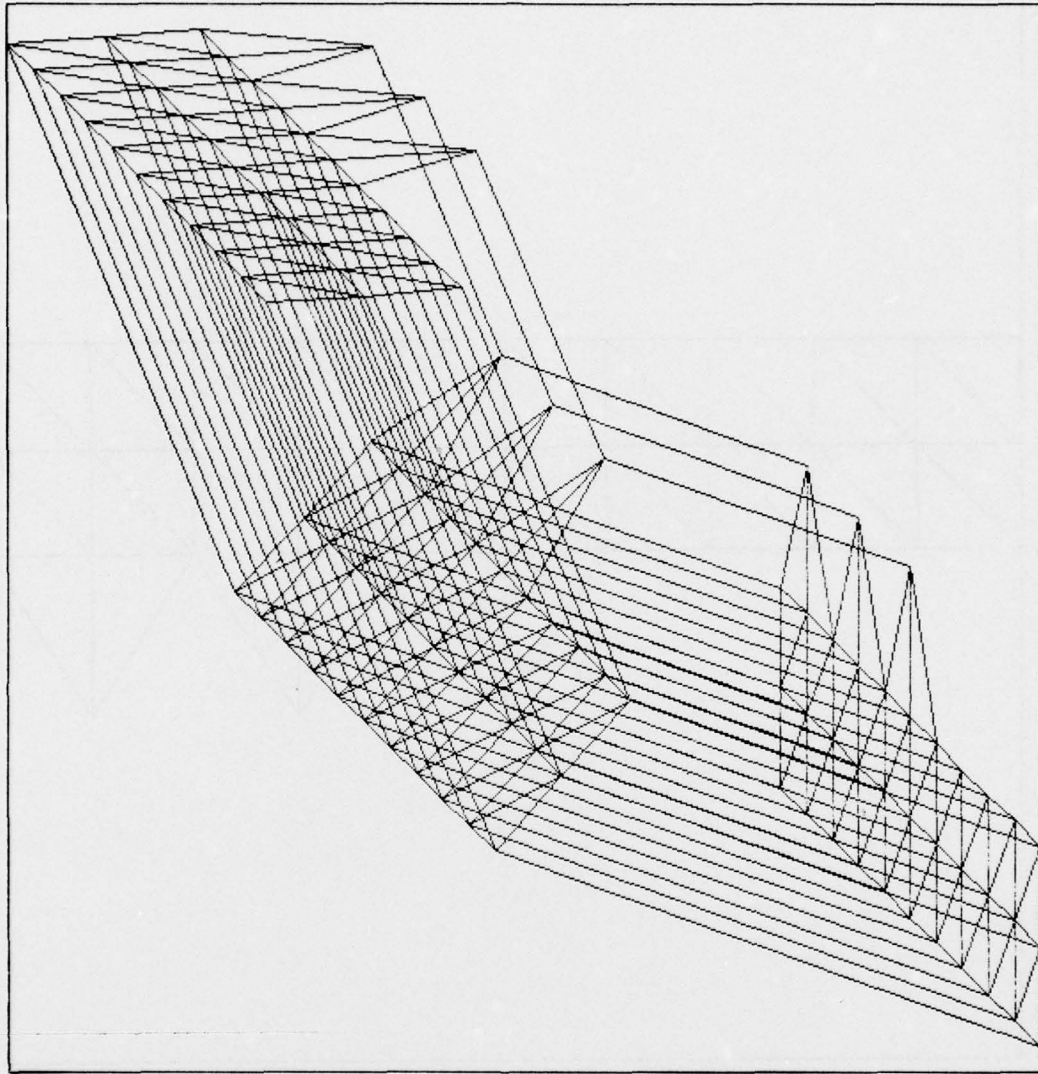

FIG. B-48 NASTRAN STRUCTURAL PLOT ROTATED VIEW

LISTING OF PUNCHED NASTRAN BULK DATA CARDS  
PROBLEM B-VII MPC GENERATOR

```
*****  
*****  
**  
** JUNCTION INPUT GENERATOR PROGRAM (JIG) **  
**  
*****  
*****
```

## \*\*\* SAMPLE 7 - JOINT WITH MPC \*\*\*

```
NST = 2  
NGS = 1  
NES = 1  
NPOP = 3  
MID = 10  
NGP = 0  
IOELT = 1  
NSECT = 1  
NT( 1) = 3 DELTZ( 1) = -1.0000  
NT( 2) = 1 DELTZ( 2) = 0.0000  
NDT = 1  
ICLOSE = 1  
DELGP = 100  
KK( 1) = 1 THETA( 1) = 0.0000  
KK( 2) = 3 THETA( 2) = 90.0000  
BETA( 1) = 0.0000  
BETA( 2) = 90.0000  
JB( 1) = 1 JE( 1) = 4
```

NSWC/WOL TR 77-85

I	J	Z(I,J)	X(I,J)	CODE(I,J)				
1	1	5.00000	4.00000	1				
2	1	4.50000	4.00000	1				
3	1	4.00000	4.00000	1				
1	2	5.00000	3.50000	1				
2	2	4.50003	3.50003	0				
3	2	4.00000	3.50000	1				
1	3	5.00000	3.00000	1				
2	3	4.50000	3.00000	1				
3	3	4.00000	3.00000	1				
1	4	4.50000	2.25000	1				
GRID	1	1	4.0000	0.0000	5.0000	1	456	
GRID	2	1	4.0000	45.0000	5.0000	1	456	
GRID	3	1	4.0000	90.0000	5.0000	1	456	
GRID	4	1	4.0000	0.0000	4.5000	1	456	
GRID	5	1	4.0000	45.0000	4.5000	1	456	
GRID	6	1	4.0000	90.0000	4.5000	1	456	
GRID	7	1	4.0000	0.0000	4.0000	1	456	
GRID	8	1	4.0000	45.0000	4.0000	1	456	
GRID	9	1	4.0000	90.0000	4.0000	1	456	
GRID	10	1	3.5000	0.0000	5.0000	1	456	
GRID	11	1	3.5000	45.0000	5.0000	1	456	
GRID	12	1	3.5000	90.0000	5.0000	1	456	
GRID	13	1	3.5000	0.0000	4.5000	1	456	
GRID	14	1	3.5000	45.0000	4.5000	1	456	
GRID	15	1	3.5000	90.0000	4.5000	1	456	
CWEDGE	1	10	13	10	1	14	11	2
CWEDGE	101	10	14	11	2	15	12	3
CWEDGE	2	10	1	4	13	2	5	14
CWEDGE	102	10	2	5	14	3	6	15
GRID	16	1	3.5000	0.0000	4.0000	1	456	
GRID	17	1	3.5000	45.0000	4.0000	1	456	
GRID	18	1	3.5000	90.0000	4.0000	1	456	
CWEDGE	3	10	16	13	4	17	14	5
CWEDGE	103	10	17	14	5	18	15	6
CWEDGE	4	10	4	7	16	5	8	17
CWEDGE	104	10	5	8	17	6	9	18
GRID	19	1	3.0000	0.0000	5.0000	1	456	
GRID	20	1	3.0000	45.0000	5.0000	1	456	
GRID	21	1	3.0000	90.0000	5.0000	1	456	
GRID	22	1	3.0000	0.0000	4.5000	1	456	
GRID	23	1	3.0000	45.0000	4.5000	1	456	
GRID	24	1	3.0000	90.0000	4.5000	1	456	
CWEDGE	5	10	22	19	10	23	20	11
CWEDGE	105	10	23	20	11	24	21	12
CWEDGE	6	10	10	13	22	11	14	23
CWEDGE	106	10	11	14	23	12	15	24
GRID	25	1	3.0000	0.0000	4.0000	1	456	
GRID	26	1	3.0000	45.0000	4.0000	1	456	
GRID	27	1	3.0000	90.0000	4.0000	1	456	
CWEDGE	7	10	25	22	13	26	23	14
CWEDGE	107	10	26	23	14	27	24	15
CWEDGE	8	10	13	16	25	14	17	26
CWEDGE	108	10	14	17	26	15	18	27
GRID	28	1	2.2500	0.0000	4.5000	1	456	
GRID	29	1	2.2500	45.0000	4.5000	1	456	
GRID	30	1	2.2500	90.0000	4.5000	1	456	
CWEDGE	9	10	22	28	19	23	29	20
CWEDGE	109	10	23	29	20	24	30	21

NSWC/WOL TR 77-85

CWEDGE	10	10	25	28	22	26	29	23
CWEDGE	110	10	26	29	23	27	38	24

	I	J	Z(I,J)	X(I,J)	CODE(I,J)				
	1	1	4.00000	4.00000	1				
	2	1	3.50000	4.00000	1				
	3	1	3.00000	4.00000	1				
	1	2	4.00000	3.50000	1				
	2	2	3.50003	3.50003	0				
	3	2	3.00000	3.50000	1				
	1	3	4.00000	3.00000	1				
	2	3	3.50000	3.00000	1				
	3	3	3.00000	3.00000	1				
	1	4	3.50000	2.25000	1				
GRID		31	1	4.0000	0.0000	3.5000	1	456	
GRID		32	1	4.0000	45.0000	3.5000	1	456	
GRID		33	1	4.0000	90.0000	3.5000	1	456	
GRID		34	1	4.0000	0.0000	3.0000	1	456	
GRID		35	1	4.0000	45.0000	3.0000	1	456	
GRID		36	1	4.0000	90.0000	3.0000	1	456	
GRID		37	1	3.5000	0.0000	3.5000	1	456	
GRID		38	1	3.5000	45.0000	3.5000	1	456	
GRID		39	1	3.5000	90.0000	3.5000	1	456	
CWEDGE		11	10	37	16	7	38	17	8
CWEDGE		111	10	38	17	8	39	18	9
CWEDGE		12	10	7	31	37	8	32	38
CWEDGE		112	10	8	32	38	9	33	39
GRID		40	1	3.5000	0.0000	3.0000	1	456	
GRID		41	1	3.5000	45.0000	3.0000	1	456	
GRID		42	1	3.5000	90.0000	3.0000	1	456	
CWEDGE		13	10	40	37	31	41	38	32
CWEDGE		113	10	41	38	32	42	39	33
CWEDGE		14	10	31	34	40	32	35	41
CWEDGE		114	10	32	35	41	33	36	42
GRID		43	1	3.0000	0.0000	3.5000	1	456	
GRID		44	1	3.0000	45.0000	3.5000	1	456	
GRID		45	1	3.0000	90.0000	3.5000	1	456	
CWEDGE		15	10	43	25	16	44	26	17
CWEDGE		115	10	44	26	17	45	27	18
CWEDGE		16	10	16	37	43	17	38	44
CWEDGE		116	10	17	38	44	18	39	45
GRID		46	1	3.0000	0.0000	3.0000	1	456	
GRID		47	1	3.0000	45.0000	3.0000	1	456	
GRID		48	1	3.0000	90.0000	3.0000	1	456	
CWEDGE		17	10	46	43	37	47	44	38
CWEDGE		117	10	47	44	38	48	45	39
CWEDGE		18	10	37	40	46	38	41	47
CWEDGE		118	10	38	41	47	39	42	48
GRID		49	1	2.2500	0.0000	3.5000	1	456	
GRID		50	1	2.2500	45.0000	3.5000	1	456	
GRID		51	1	2.2500	90.0000	3.5000	1	456	
CWEDGE		19	10	43	49	25	44	50	26
CWEDGE		119	10	44	50	26	45	51	27
CWEDGE		20	10	46	49	43	47	50	44
CWEDGE		120	10	47	50	44	48	51	45

I	J	Z(I,J)	X(I,J)	CODE(I,J)
1	1	3.00000	4.00000	1

NSWC/WOL TR 77-85

2	1	2.50000	4.00000	1				
3	1	2.00000	4.00000	1				
1	2	3.00000	3.50000	1				
2	2	2.50003	3.50003	0				
3	2	2.00000	3.50000	1				
1	3	3.00000	3.00000	1				
2	3	2.50000	3.00000	1				
3	3	2.00000	3.00000	1				
1	4	2.50000	2.25000	1				
GRID	52	1	4.0000	0.0000	2.5000	1	456	
GRID	53	1	4.0000	45.0000	2.5000	1	456	
GRID	54	1	4.0000	90.0000	2.5000	1	456	
GRID	55	1	4.0000	0.0000	2.0000	1	456	
GRID	56	1	4.0000	45.0000	2.0000	1	456	
GRID	57	1	4.0000	90.0000	2.0000	1	456	
GRID	58	1	3.5000	0.0000	2.5000	1	456	
GRID	59	1	3.5000	45.0000	2.5000	1	456	
GRID	60	1	3.5000	90.0000	2.5000	1	456	
CWEDGE	21	10	58	40	34	59	41	35
CWEDGE	121	10	59	41	35	60	42	36
CWEDGE	22	10	34	52	58	35	53	59
CWEDGE	122	10	35	53	59	36	54	60
GRID	61	1	3.5000	0.0000	2.0000	1	456	
GRID	62	1	3.5000	45.0000	2.0000	1	456	
GRID	63	1	3.5000	90.0000	2.0000	1	456	
CWEDGE	23	10	61	58	52	62	59	53
CWEDGE	123	10	62	59	53	63	60	54
CWEDGE	24	10	52	55	61	53	56	62
CWEDGE	124	10	53	56	62	54	57	63
GRID	64	1	3.0000	0.0000	2.5000	1	456	
GRID	65	1	3.0000	45.0000	2.5000	1	456	
GRID	66	1	3.0000	90.0000	2.5000	1	456	
CWEDGE	25	10	64	46	40	65	47	41
CWEDGE	125	10	65	47	41	66	48	42
CWEDGE	26	10	40	58	64	41	59	65
CWEDGE	126	10	41	59	65	42	60	66
GRID	67	1	3.0000	0.0000	2.0000	1	456	
GRID	68	1	3.0000	45.0000	2.0000	1	456	
GRID	69	1	3.0000	90.0000	2.0000	1	456	
CWEDGE	27	10	67	64	58	68	65	59
CWEDGE	127	10	68	65	59	69	66	60
CWEDGE	28	10	58	61	67	59	62	68
CWEDGE	128	10	59	62	68	60	63	69
GRID	70	1	2.2500	0.0000	2.5000	1	456	
GRID	71	1	2.2500	45.0000	2.5000	1	456	
GRID	72	1	2.2500	90.0000	2.5000	1	456	
CWEDGE	29	10	64	70	46	65	71	47
CWEDGE	129	10	65	71	47	66	72	48
CWEDGE	30	10	67	70	64	68	71	65
CWEDGE	130	10	68	71	65	69	72	66

I	J	Z(I,J)	X(I,J)	CODE(I,J)
1	1	2.00000	4.00000	1
2	1	1.50000	4.00000	1
3	1	1.00000	4.00000	1
4	1	.50000	4.00000	1
5	1	0.00000	4.00000	1
1	2	2.00000	3.50000	1
2	2	1.50001	3.50001	0
3	2	1.00001	3.50001	0
4	2	.50001	3.50003	0

NSWC/WOL TR 77-85

5	2	0.00000	3.50000	2				
1	3	2.00000	3.00000	1				
2	3	1.50000	3.00000	1				
3	3	1.00000	3.00000	1				
4	3	.50000	3.00000	1				
5	3	0.00000	3.00000	1				
GRID	73	1	4.0000	0.0000	1.5000	1	456	
GRID	74	1	4.0000	45.0000	1.5000	1	456	
GRID	75	1	4.0000	90.0000	1.5000	1	456	
GRID	76	1	4.0000	0.0000	1.0000	1	456	
GRID	77	1	4.0000	45.0000	1.0000	1	456	
GRID	78	1	4.0000	90.0000	1.0000	1	456	
GRID	79	1	4.0000	0.0000	.5000	1	456	
GRID	80	1	4.0000	45.0000	.5000	1	456	
GRID	81	1	4.0000	90.0000	.5000	1	456	
GRID	82	1	4.0000	0.0000	0.0000	1	2456	
GRID	83	1	4.0000	45.0000	0.0000	1	456	
GRID	84	1	4.0000	90.0000	0.0000	1	2456	
GRID	85	1	3.5000	0.0000	1.5000	1	456	
GRID	86	1	3.5000	45.0000	1.5000	1	456	
GRID	87	1	3.5000	90.0000	1.5000	1	456	
CWEDGE	31	10	85	61	55	86	62	56
CWEDGE	131	10	86	62	56	87	63	57
CWEDGE	32	10	55	73	85	56	74	86
CWEDGE	132	10	56	74	86	57	75	87
GRID	88	1	3.5000	0.0000	1.0000	1	456	
GRID	89	1	3.5000	45.0000	1.0000	1	456	
GRID	90	1	3.5000	90.0000	1.0000	1	456	
CWEDGE	33	10	88	85	73	89	86	74
CWEDGE	133	10	89	86	74	90	87	75
CWEDGE	34	10	73	76	88	74	77	89
CWEDGE	134	10	74	77	89	75	78	90
GRID	91	1	3.5000	0.0000	.5000	1	456	
GRID	92	1	3.5000	45.0000	.5000	1	456	
GRID	93	1	3.5000	90.0000	.5000	1	456	
CWEDGE	35	10	91	88	76	92	89	77
CWEDGE	135	10	92	89	77	93	90	78
CWEDGE	36	10	76	79	91	77	80	92
CWEDGE	136	10	77	80	92	78	81	93
GRID	1000	1	3.5000	0.0000	0.0000	1	246	
GRID	1001	1	3.5000	45.0000	0.0000	1	246	
GRID	1002	1	3.5000	90.0000	0.0000	1	246	
CWEDGE	37	10	1000	91	79	1001	92	80
CWEDGE	137	10	1001	92	80	1002	93	81
CWEDGE	38	10	79	82	1000	80	83	1001
CWEDGE	138	10	80	83	1001	81	84	1002
GRID	94	1	3.0000	0.0000	1.5000	1	456	
GRID	95	1	3.0000	45.0000	1.5000	1	456	
GRID	96	1	3.0000	90.0000	1.5000	1	456	
CWEDGE	39	10	94	67	61	95	68	62
CWEDGE	139	10	95	68	62	96	69	63
CWEDGE	40	10	61	85	94	62	86	95
CWEDGE	140	10	62	86	95	63	87	96
GRID	97	1	3.0000	0.0000	1.0000	1	456	
GRID	98	1	3.0000	45.0000	1.0000	1	456	
GRID	99	1	3.0000	90.0000	1.0000	1	456	
CWEDGE	41	10	97	94	85	98	95	86
CWEDGE	141	10	98	95	86	99	96	87
CWEDGE	42	10	85	88	97	86	89	98
CWEDGE	142	10	86	89	98	87	90	99
GRID	100	1	3.0000	0.0000	.5000	1	456	
GRID	101	1	3.0000	45.0000	.5000	1	456	
GRID	102	1	3.0000	90.0000	.5000	1	456	
CWEDGE	43	10	100	97	88	101	98	89

NSWC/WOL TR 77-85

CWEDGE	143	10	101	98	89	102	99	90
CWEDGE	44	10	88	91	100	89	92	101
CWEDGE	144	10	89	92	101	90	93	102
GRID	103	1	3.000	0.000	0.000	1	2456	
GRID	104	1	3.000	45.000	0.000	1	456	
GRID	105	1	3.000	90.000	0.000	1	2456	
MPC	1	82	1	1.000	1000	1	-1.000	
MPC	1	103	1	1.000	1000	1	-1.000	
MPC	1	82	3	1.000	1000	5	.500	+ 1
+ 1		1000	3	-1.000				
MPC	1	103	3	1.000	1000	5	-.500	+ 2
+ 2		1000	3	-1.000				
MPC	1	83	1	1.000	1001	1	-1.000	
MPC	1	104	1	1.000	1001	1	-1.000	
MPC	1	83	2	1.000	1001	6	-.500	+ 3
+ 3		1001	2	-1.000				
MPC	1	104	2	1.000	1001	6	.500	+ 4
+ 4		1001	2	-1.000				
MPC	1	83	3	1.000	1001	5	.500	+ 5
+ 5		1001	3	-1.000				
MPC	1	104	3	1.000	1001	5	-.500	+ 6
+ 6		1001	3	-1.000				
MPC	1	84	1	1.000	1002	1	-1.000	
MPC	1	105	1	1.000	1002	1	-1.000	
MPC	1	84	3	1.000	1002	5	.500	+ 7
+ 7		1002	3	-1.000				
MPC	1	105	3	1.000	1002	5	-.500	+ 8
+ 8		1002	3	-1.000				
CWEDGE	45	10	103	100	91	104	101	92
CWEDGE	145	10	104	101	92	105	102	93
CWEDGE	46	10	91	1000	103	92	1001	104
CWEDGE	146	10	92	1001	104	93	1002	105

PROBLEM B-VIII

CURVED BOUNDARY

This problem illustrates the use of the curved boundary option. Figure B-49 shows the planned finite element model and configuration of a missile nozzle. The outer surface of the nozzle has a constant radius of 6.5 inches. The inner surface is represented by two third ordered curves. (see Figure B-49)

A complete listing of the data input is shown in Figure B-50. Figure B-51 shows the grid point and element identification numbers as generated by JIG. Figure B-52 gives the NASTRAN structural plot of the finite element model and is followed by a listing of the JIG punched output.

AD-A049 663

NAVAL SURFACE WEAPONS CENTER WHITE OAK LAB SILVER SP--ETC F/G 13/13  
JUNCTION INPUT GENERATOR (JIG), A NASTRAN PRE-PROCESSOR; THEORE--ETC(U)  
SEP 77 P C HUANG; K C KIDDY; J P MATRA  
NSWC/WOL/TR-77-85

UNCLASSIFIED

NL

3 OF 3

AD  
A049663

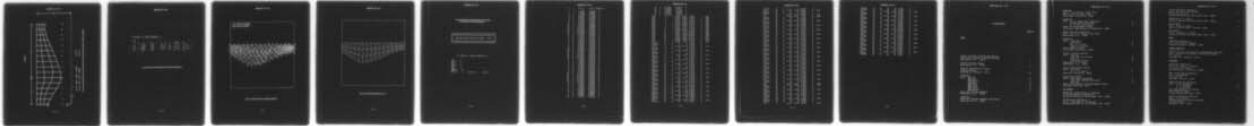

END  
DATE  
FILMED  
3 - 78  
DDC



```

*** SAMPLE 8 - CURVED BOUNDARY ***
  1  1  1  1  5  0  0  0
  1
  0.0
  6  1  4  1  16  0  0  0  0  0  2456  0
  1  1  0.0  4.5  2  6  1  5.0  2.0  2
  4.5  -0.375  -0.15  .025  0.0  0.0  0.0
  16  1  15.0  5.0  1  16  4  15.0  6.5  1
  5.0  -1.35  .18  -0.006  0.0  0.0  0.0
  6  4  5.0  6.5  1  1  4  0.0  6.5  1
  
```

FIG. B-50 DATA INPUT PROBLEM B-VIII CURVED BOUNDARY

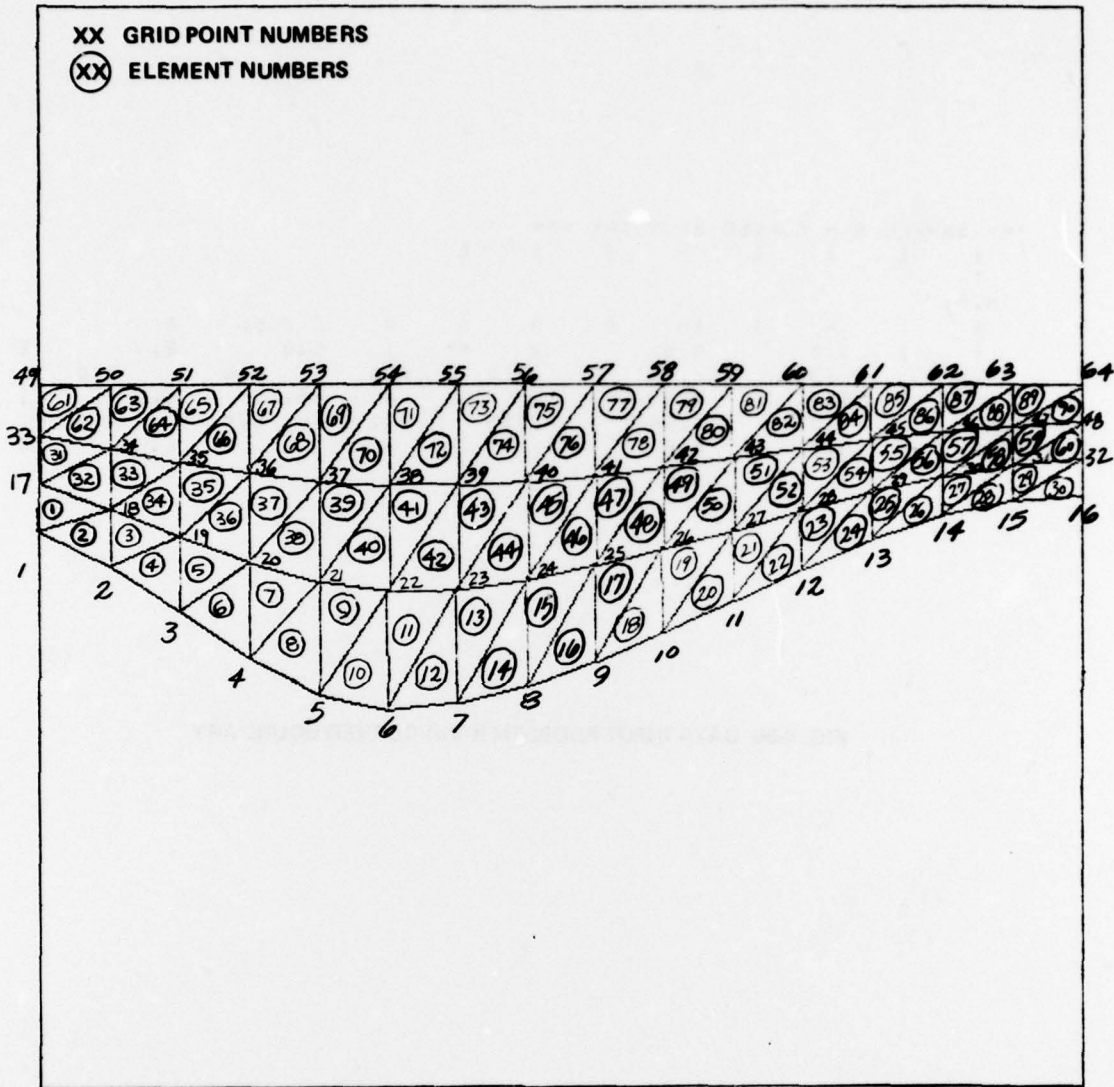

FIG. B-51 GRID POINT AND ELEMENT NUMBERS

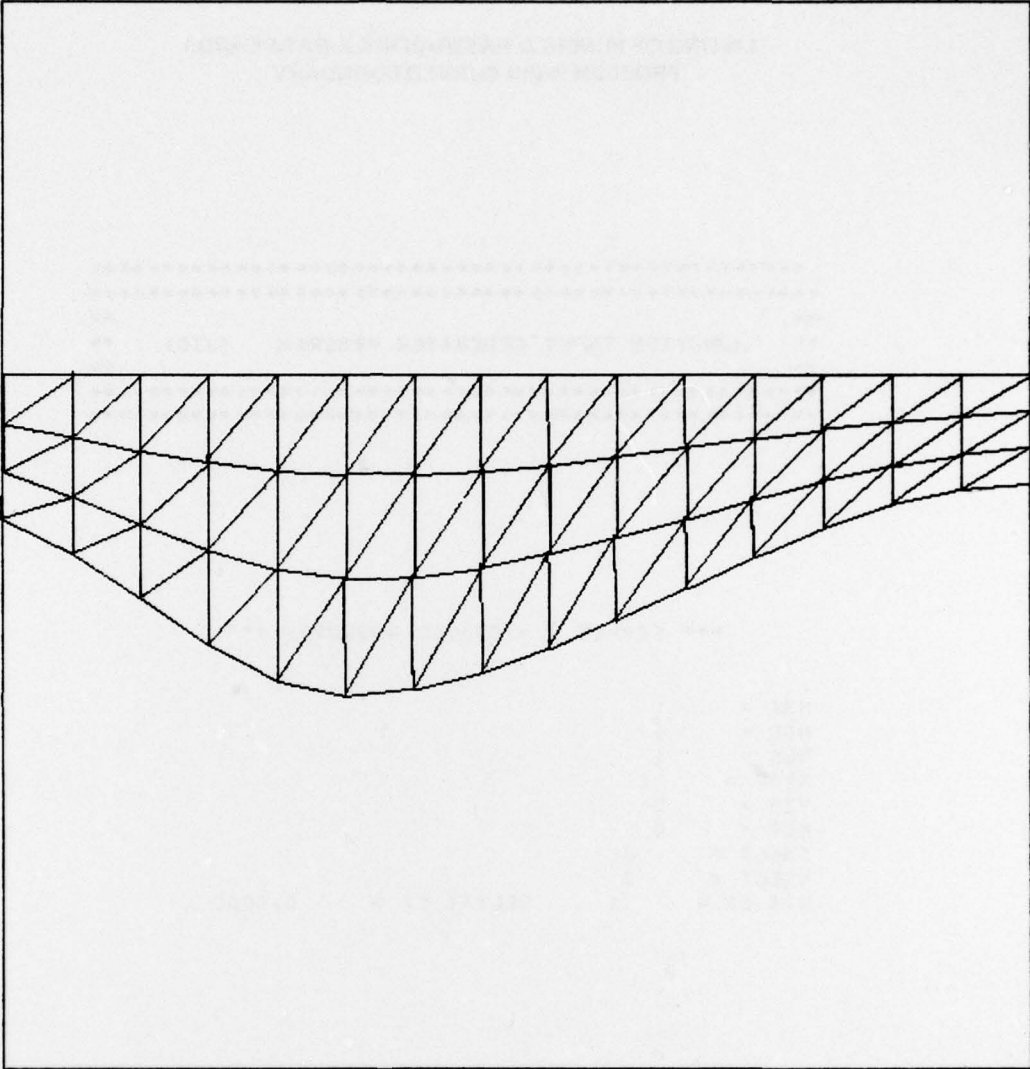

FIG. B-52 NASTRAN STRUCTURAL PLOT

LISTING OF PUNCHED NASTRAN BULK DATA CARDS  
PROBLEM B-VIII CURVED BOUNDARY

```
*****  
*****  
**  
** JUNCTION INPUT GENERATOR PROGRAM (JIG) **  
**  
*****  
*****
```

\*\*\* SAMPLE 8 - CURVED BOUNDARY \*\*\*

```
NST = 1  
NGS = 1  
NES = 1  
NPOP = 1  
MID = 5  
NGP = 0  
IDELT = 0  
NSECT = 0  
NT( 1) = 1      DELTZ( 1) = 0.0000
```

## NSWC/WOL TR 77-85

I	J	Z(I,J)	X(I,J)	CODE(I,J)
1	1	0.00000	4.50000	1
2	1	1.00000	4.00000	1
3	1	2.00000	3.35000	1
4	1	3.00000	2.70000	1
5	1	4.00000	2.20000	1
6	1	5.00000	2.00000	1
7	1	6.00000	2.08400	1
8	1	7.00000	2.31200	1
9	1	8.00000	2.64800	1
10	1	9.00000	3.05600	1
11	1	10.00000	3.50000	1
12	1	11.00000	3.94400	1
13	1	12.00000	4.35200	1
14	1	13.00000	4.68800	1
15	1	14.00000	4.91600	1
16	1	15.00000	5.00000	1
1	2	0.00000	5.16667	1
2	2	1.00010	4.80871	0
3	2	2.00012	4.41625	0
4	2	3.00002	4.04117	0
5	2	4.00005	3.75669	0
6	2	5.00011	3.62439	0
7	2	6.00009	3.64463	0
8	2	7.00007	3.77120	0
9	2	8.00005	3.97329	0
10	2	9.00006	4.22474	0
11	2	10.00005	4.50092	0
12	2	11.00003	4.77801	0
13	2	12.00001	5.03313	0
14	2	13.00001	5.24558	0
15	2	14.00002	5.40047	0
16	2	15.00000	5.50000	1
1	3	0.00000	5.83333	1
2	3	1.00004	5.65176	0
3	3	1.99995	5.46491	0
4	3	2.99995	5.29179	0
5	3	4.00000	5.16115	0
6	3	5.00003	5.09611	0
7	3	6.00000	5.09888	0
8	3	6.99999	5.15481	0
9	3	8.00002	5.24921	0
10	3	9.00003	5.36872	0
11	3	10.00002	5.50090	0
12	3	11.00001	5.63397	0
13	3	12.00000	5.75695	0
14	3	13.00001	5.86071	0
15	3	14.00002	5.94030	0
16	3	15.00000	6.00000	1
1	4	0.00000	6.50000	1
2	4	1.00000	6.50000	1
3	4	2.00000	6.50000	1
4	4	3.00000	6.50000	1
5	4	4.00000	6.50000	1
6	4	5.00000	6.50000	1
7	4	6.00000	6.50000	1
8	4	7.00000	6.50000	1
9	4	8.00000	6.50000	1
10	4	9.00000	6.50000	1

NSWC/WOL TR 77-85

11	4	10.00000	6.50000	1			
12	4	11.00000	6.50000	1			
13	4	12.00000	6.50000	1			
14	4	13.00000	6.50000	1			
15	4	14.00000	6.50000	1			
16	4	15.00000	6.50000	1			
GRID	1	0	4.5000	0.0000	0.0000	0	2456
GRID	2	0	4.0000	0.0000	1.0000	0	2456
GRID	3	0	3.3500	0.0000	2.0000	0	2456
GRID	4	0	2.7000	0.0000	3.0000	0	2456
GRID	5	0	2.2000	0.0000	4.0000	0	2456
GRID	6	0	2.0000	0.0000	5.0000	0	2456
GRID	7	0	2.0840	0.0000	6.0000	0	2456
GRID	8	0	2.3120	0.0000	7.0000	0	2456
GRID	9	0	2.6480	0.0000	8.0000	0	2456
GRID	10	0	3.0560	0.0000	9.0000	0	2456
GRID	11	0	3.5000	0.0000	10.0000	0	2456
GRID	12	0	3.9440	0.0000	11.0000	0	2456
GRID	13	0	4.3520	0.0000	12.0000	0	2456
GRID	14	0	4.6880	0.0000	13.0000	0	2456
GRID	15	0	4.9160	0.0000	14.0000	0	2456
GRID	16	0	5.0000	0.0000	15.0000	0	2456
GRID	17	0	5.1667	0.0000	0.0000	0	2456
GRID	18	0	4.8087	0.0000	1.0001	0	2456
CTRIARG	1	19	17	1	0.0000	5	
CTRIARG	2	1	2	18	0.0000	5	
GRID	19	0	4.4162	0.0000	2.0001	0	2456
CTRIARG	3	19	18	2	0.0000	5	
CTRIARG	4	2	3	19	0.0000	5	
GRID	20	0	4.0412	0.0000	3.0000	0	2456
CTRIARG	5	20	19	3	0.0000	5	
CTRIARG	6	3	4	20	0.0000	5	
GRID	21	0	3.7567	0.0000	4.0001	0	2456
CTRIARG	7	21	20	4	0.0000	5	
CTRIARG	8	4	5	21	0.0000	5	
GRID	22	0	3.6244	0.0000	5.0001	0	2456
CTRIARG	9	22	21	5	0.0000	5	
CTRIARG	10	5	6	22	0.0000	5	
GRID	23	0	3.6446	0.0000	6.0001	0	2456
CTRIARG	11	23	22	6	0.0000	5	
CTRIARG	12	6	7	23	0.0000	5	
GRID	24	0	3.7712	0.0000	7.0001	0	2456
CTRIARG	13	24	23	7	0.0000	5	
CTRIARG	14	7	8	24	0.0000	5	
GRID	25	0	3.9733	0.0000	8.0001	0	2456
CTRIARG	15	25	24	8	0.0000	5	
CTRIARG	16	8	9	25	0.0000	5	
GRID	26	0	4.2247	0.0000	9.0001	0	2456
CTRIARG	17	26	25	9	0.0000	5	
CTRIARG	18	9	10	26	0.0000	5	
GRID	27	0	4.5009	0.0000	10.0001	0	2456
CTRIARG	19	27	26	10	0.0000	5	
CTRIARG	20	10	11	27	0.0000	5	
GRID	28	0	4.7780	0.0000	11.0000	0	2456
CTRIARG	21	28	27	11	0.0000	5	
CTRIARG	22	11	12	28	0.0000	5	
GRID	29	0	5.0331	0.0000	12.0000	0	2456
CTRIARG	23	29	28	12	0.0000	5	
CTRIARG	24	12	13	29	0.0000	5	
GRID	30	0	5.2456	0.0000	13.0000	0	2456
CTRIARG	25	30	29	13	0.0000	5	
CTRIARG	26	13	14	30	0.0000	5	
GRID	31	0	5.4085	0.0000	14.0000	0	2456
CTRIARG	27	31	30	14	0.0000	5	

NSWC/WOL TR 77-85

CTRIARG	28	14	15	31	0.0000	5	
GRID	32	J	5.5000	0.0000	15.0000	0	24 56
CTRIARG	29	32	31	15	0.0000	5	
CTRIARG	30	15	16	32	0.0000	5	
GRID	33	J	5.8333	0.0000	0.0000	0	24 56
GRID	34	J	5.6518	0.0000	1.0000	0	24 56
CTRIARG	31	34	33	17	0.0000	5	
CTRIARG	32	17	18	34	0.0000	5	
GRID	35	0	5.4649	0.0000	2.0000	0	24 56
CTRIARG	33	35	34	18	0.0000	5	
CTRIARG	34	18	19	35	0.0000	5	
GRID	36	0	5.2918	0.0000	2.9999	0	24 56
CTRIARG	35	36	35	19	0.0000	5	
CTRIARG	36	19	20	36	0.0000	5	
GRID	37	0	5.1611	0.0000	4.0000	0	24 56
CTRIARG	37	37	36	20	0.0000	5	
CTRIARG	38	20	21	37	0.0000	5	
GRID	38	J	5.0961	0.0000	5.0000	0	24 56
CTRIARG	39	38	37	21	0.0000	5	
CTRIARG	40	21	22	38	0.0000	5	
GRID	39	0	5.0989	0.0000	6.0000	0	24 56
CTRIARG	41	39	38	22	0.0000	5	
CTRIARG	42	22	23	39	0.0000	5	
GRID	40	0	5.1548	0.0000	7.0000	0	24 56
CTRIARG	43	40	39	23	0.0000	5	
CTRIARG	44	23	24	40	0.0000	5	
GRID	41	J	5.2492	0.0000	8.0000	0	24 56
CTRIARG	45	41	40	24	0.0000	5	
CTRIARG	46	24	25	41	0.0000	5	
GRID	42	0	5.3687	0.0000	9.0000	0	24 56
CTRIARG	47	42	41	25	0.0000	5	
CTRIARG	48	25	26	42	0.0000	5	
GRID	43	0	5.5009	0.0000	10.0000	0	24 56
CTRIARG	49	43	42	26	0.0000	5	
CTRIARG	50	26	27	43	0.0000	5	
GRID	44	0	5.6340	0.0000	11.0000	0	24 56
CTRIARG	51	44	43	27	0.0000	5	
CTRIARG	52	27	28	44	0.0000	5	
GRID	45	J	5.7570	0.0000	12.0000	0	24 56
CTRIARG	53	45	44	28	0.0000	5	
CTRIARG	54	28	29	45	0.0000	5	
GRID	46	0	5.8607	0.0000	13.0000	0	24 56
CTRIARG	55	46	45	29	0.0000	5	
CTRIARG	56	29	30	46	0.0000	5	
GRID	47	0	5.9403	0.0000	14.0000	0	24 56
CTRIARG	57	47	46	30	0.0000	5	
CTRIARG	58	30	31	47	0.0000	5	
GRID	48	0	6.0000	0.0000	15.0000	0	24 56
CTRIARG	59	48	47	31	0.0000	5	
CTRIARG	60	31	32	48	0.0000	5	
GRID	49	0	6.5000	0.0000	0.0000	0	24 56
GRID	50	0	6.5000	0.0000	1.0000	0	24 56
CTRIARG	61	50	49	33	0.0000	5	
CTRIARG	62	33	34	50	0.0000	5	
GRID	51	0	6.5000	0.0000	2.0000	0	24 56
CTRIARG	63	51	50	34	0.0000	5	
CTRIARG	64	34	35	51	0.0000	5	
GRID	52	0	6.5000	0.0000	3.0000	0	24 56
CTRIARG	65	52	51	35	0.0000	5	
CTRIARG	66	35	36	52	0.0000	5	
GRID	53	0	6.5000	0.0000	4.0000	0	24 56
CTRIARG	67	53	52	36	0.0000	5	
CTRIARG	68	36	37	53	0.0000	5	
GRID	54	0	6.5000	0.0000	5.0000	0	24 56

NSWC/WOL TR 77-85

CTRIARG	69	54	53	37	0.0000	5	
CTRIARG	70	37	38	54	0.0000	5	
GRID	55	0	6.5000	0.0000	6.0000	0	24 56
CTRIARG	71	55	54	38	0.0000	5	
CTRIARG	72	38	39	55	0.0000	5	
GRID	56	0	6.5000	0.0000	7.0000	0	24 56
CTRIARG	73	56	55	39	0.0000	5	
CTRIARG	74	39	40	56	0.0000	5	
GRID	57	0	6.5000	0.0000	8.0000	0	24 56
CTRIARG	75	57	56	40	0.0000	5	
CTRIARG	76	40	41	57	0.0000	5	
GRID	58	0	6.5000	0.0000	9.0000	0	24 56
CTRIARG	77	58	57	41	0.0000	5	
CTRIARG	78	41	42	58	0.0000	5	
GRID	59	0	6.5000	0.0000	10.0000	0	24 56
CTRIARG	79	59	58	42	0.0000	5	
CTRIARG	80	42	43	59	0.0000	5	
GRID	60	0	6.5000	0.0000	11.0000	0	24 56
CTRIARG	81	60	59	43	0.0000	5	
CTRIARG	82	43	44	60	0.0000	5	
GRID	61	0	6.5000	0.0000	12.0000	0	24 56
CTRIARG	83	61	60	44	0.0000	5	
CTRIARG	84	44	45	61	0.0000	5	
GRID	62	0	6.5000	0.0000	13.0000	0	24 56
CTRIARG	85	62	61	45	0.0000	5	
CTRIARG	86	45	46	62	0.0000	5	
GRID	63	0	6.5000	0.0000	14.0000	0	24 56
CTRIARG	87	63	62	46	0.0000	5	
CTRIARG	88	46	47	63	0.0000	5	
GRID	64	0	6.5000	0.0000	15.0000	0	24 56
CTRIARG	89	64	63	47	0.0000	5	
CTRIARG	90	47	48	64	0.0000	5	

**DISTRIBUTION**

**Copies**

NAVY

Office of Chief of Naval Operations  
 Operations Evaluation Group (OP-03EG)  
 Washington, D.C. 20350

1

Defense Nuclear Agency  
 Washington, D.C. 20301

2

Defense Documentation Center  
 Cameron Station  
 Alexandria, Virginia 22314

12

Commander

Attn: SEA- 03B  
 SEA-0333  
 SEA-035-13  
 SEA-035A  
 SEA-55212  
 SEA- 09G32  
 SEA-654312  
 PMS-403-02

1  
 1  
 2  
 1  
 1  
 2  
 1  
 1

Naval Sea Systems Command  
 Washington, D.C. 20360

Commander

Naval Air Systems Command (AIR-320-B)  
 Washington, D.C. 20360

1

Commander Attn: T. W. Elliott (Code 5331) Pacific Missile Test Center Point Mugu, California 93042	1
Commander Attn: Dr. E. McQuillan (Code 3033) Herman Rubin (Code 3033) K. T. Yen (Code 30331) Naval Air Development Center Johnsville, Warminister, Pennsylvania 18974	1 1 1
Naval Research Laboratory Attn: Dr. M. R. Achter (Code 6340) Washington, D.C. 20390	1
Commander Attn: Code 4062 Code 45703 Mr. E. L. Jeter James E. Serpanos Naval Weapons Center China Lake, California 93557	1 1 1 1
Office of Naval Research Attn: Code 461 Code 439 (N. Perrone) Code 470 Technical Library Department of the Navy Washington, D.C. 20360	1 1 1 2
Naval Postgraduate School Attn: Code 2124 Dr. J. G. Cantin Monterey, California 93940	1 1
Commanding Officer Attn: Code 1844 (Jim McKee) Code 1844 (Gordon Everstine) Code 564 Naval Ship Research and Development Center Bethesda, Maryland 20034	1 1 2
<u>AIR FORCE</u>	
AFFDL/PTS (CAPT Gilbert L. Camburn) AF Flight Dynamics Laboratory Wright-Patterson Air Force Base, Ohio 45433	1
AF Materials Laboratory Attn: Code MAAN (B. R. Emrich) Wright-Patterson Air Force Base, Ohio 45433	1

Flight Dynamics Laboratory  
 Attn: Mr. Leo J. D. Bernier 1  
 Structures Division  
 Wright-Patterson Air Force Base, Ohio 45433

AFML/LLM (W. G. Ramke)  
 Wright Patterson Air Force Base, Ohio 45433 1

AFATL/DLRV  
 Attn: James M. Heard 2  
 Eglin Air Force Base, Florida 32542

AFAL/TEM-3  
 Attn: Richard A. Ireland 1  
 Wright-Patterson Air Force Base, Ohio 45433

ARMY

Commanding General  
 U.S. Army Missile Command  
 Redstone Arsenal, Alabama 35809 1

OTHER AGENCIES

NASA Scientific and Technical Information Facility  
 Attn: Acquisitions Branch - Foreign Exchange 2  
 P.O. Box 33  
 College Park, Maryland 20740

INDUSTRY

Aerospace Corporation  
 Attn: Dr. Robert L. Hallse 1  
 1111 East Mill Street  
 San Bernardino, California 92408

Booz Allen Applied Research  
 Attn: William Day 1  
 P.O. Box 874  
 Shalimar, Florida 32579

Applied Physics Laboratory  
 Attn: L. B. Weckesser 1  
           W. C. Caywood 1  
           R. M. Rivello 1

The Johns Hopkins University  
 8621 Georgia Avenue  
 Silver Spring, Maryland 20910

Battelle Memorial Institute  
 Attn. H. D. Moran 1  
 Defense Metals Information Center  
 505 King Avenue  
 Columbus, Ohio 43201

Brunswick Corporation Attn: Robert Copeland Technical Products Division 325 Brunswick Lane Marion, Virginia 24354	1
General Dynamics/Pomona Attn: R. A. Miller D. A. Underhill P.O. Box 2507 Pomona, California 91766	1 1
University of Maryland Attn: Dr. Schaeffer College Park, Maryland 20740	1
Raytheon Company Attn: R. D. Howe D. H. Sanders Missile Systems Division, VB1-3 Hartwell Road Bedford, Massachusetts 01730	1 1
McDonnell Douglas Astronautics Co. Attn. W. F. Bozich K. K. Wang R. S. Lee 5301 Bolsa Avenue Huntington Beach, California 92647	1 1 1
McDonnell Douglas Astronautics Co. Attn. J. Gubser Eastern Division P.O. Box 516 St. Louis, Missouri 63166	1
McDonnell Douglas Astronautics Co. Attn: Dept A-263 3000 Ocean Park Boulevard Santa Monica, California 90406	1
Lockheed Missiles and Space Co. Attn: A. Bailie Dept. 81-12, Building 154 Box 504 Sunnyvale, California 94088	1
Lockheed Missile and Space Co. Attn: Robert M. Beasley Senior Staff Scientist Dept. 52-30, Building 103 P.O. Box 504 Sunnyvale, California 94088	1 1

Lockheed Missile and Space Co. Technical Information Center 3251 Hanover Street Palo Alto, California 94034	1
Hughes Aircraft Company Attn: R. J. Oedy Missile System Division Canoga Park, California 91340	1
Hughes Aircraft Company Attn: L. E. Gates, M.S. H-164 Culver City, California 90230	1
The Boeing Company Attn: R. Blaisdell K. Brettmann P.O. Box 3999 Seattle, Washington 98124	1 1
Martin-Marietta Corporation Attn: G. H. Sprague, Jr. (Director Aeromechanical Division) G. Fotieo P.O. Box 5837 Orlando, Florida 32805	1 1
Honeywell, Incorporated Attn: J. D. Brannan 600 2nd Street North Hopkins, Minnesota 55343	1
Fairchild Republic Co. Attn: Jim Clarke Mail Stop Z-19A-08 Farmingdale, New York 11735	1 1
Raytheon Co. Attn: Doris A. Holden Dept. 7113 Spencer Lab Burlington, Massachusetts 01803	1 1 1
Headquarters Air Force Special Communications Center USAFSS San Antonio, Texas 78243	

TO AID IN UPDATING THE DISTRIBUTION LIST  
FOR NAVAL SURFACE WEAPONS CENTER, WHITE  
OAK LABORATORY TECHNICAL REPORTS PLEASE  
COMPLETE THE FORM BELOW:

TO ALL HOLDERS OF NSWC/WOL TR 77-85  
by Pao C. Huang, Code WA-30  
DO NOT RETURN THIS FORM IF ALL INFORMATION IS CURRENT

A. FACILITY NAME AND ADDRESS (OLD) (Show Zip Code) \_\_\_\_\_

NEW ADDRESS (Show Zip Code) \_\_\_\_\_

B. ATTENTION LINE ADDRESSES: \_\_\_\_\_

C. \_\_\_\_\_

REMOVE THIS FACILITY FROM THE DISTRIBUTION LIST FOR TECHNICAL REPORTS ON THIS SUBJECT.

D. NUMBER OF COPIES DESIRED \_\_\_\_\_

