

AD-A049 683

SOUTHWEST RESEARCH INST SAN ANTONIO TEX
RF CANCELLATION CIRCUIT FOR SHORE-BASED VHF FM TRANSCEIVER.(U)
JAN 78 W G GUION, T A MILLINGTON

F/O 17/2.1

DOT-CG-73125-A

UNCLASSIFIED

NL

| OF |
AD-A049683



END
DATE
FILMED
3-78
DDC

AD A 049683

122

RF CANCELLATION CIRCUIT FOR SHORE-BASED VHF FM TRANSCEIVER

By

W. G. Guion
T. A. Millington

Final Report for
Contract DOT-CG-73125-A
SwRI Project 16-4928

Prepared for
U. S. Coast Guard
400 Seventh Street, S. W.
Washington, DC 20590

13 January 1978

DDC
RECEIVED
FEB 8 1978
B

AD NO. []
JDC FILE COPY

DISTRIBUTION STATEMENT A
Approved for public release;
Distribution Unlimited



SOUTHWEST RESEARCH INSTITUTE
SAN ANTONIO CORPUS CHRISTI HOUSTON

SOUTHWEST RESEARCH INSTITUTE
Post Office Drawer 28510, 6220 Culebra Road
San Antonio, Texas 78284

6
**RE CANCELLATION CIRCUIT
FOR SHORE-BASED VHF FM TRANSCEIVER.**

By

10
W. G./Guion
T. A./Millington

15 9 Final Report for
Contract DOT-CG-73125-A new
SwRI Project 16-4928

Prepared for

U. S. Coast Guard
400 Seventh Street, S. W.
Washington, DC 20590

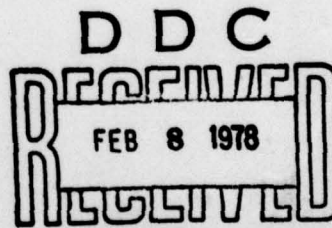

11 13 Jan [redacted] 78

12 /66p.

Approved:

Douglas N. Travers
Douglas N. Travers
Vice President
Electromagnetics Division

DISTRIBUTION STATEMENT A
Approved for public release;
Distribution Unlimited

328 200

AM

TABLE OF CONTENTS

| | | <u>Page</u> |
|----------------------------------------------------------------|--------------------------------------------------------------------------|-------------|
| | List of Illustrations | iii |
| | List of Tables | iv |
| 1.0 | Purpose | 1 |
| 2.0 | Introduction | 2 |
| 3.0 | Work Performed | 3 |
| 3.1 | Component and Circuit Technique Identification and Analysis | 3 |
| 3.2 | Performance Evaluation of Candidate Components and Circuit Techniques | 6 |
| 3.2.1 | Configuration 1 Description | 6 |
| 3.2.2 | Configuration 2 Description | 9 |
| 3.2.2.1 | Circuit Development | 11 |
| 3.2.2.2 | Final Circuit Description | 18 |
| 3.3 | System Field Tests | 29 |
| 3.4 | Production RF Cancellation Assembly | 38 |
| 4.0 | Conclusions and Recommendations | 46 |
| Appendix A--Specification for Modular RF Cancellation Assembly | | 47 |

| | |
|---------------------------------|---------------------------------------------------|
| ACCESSION for | |
| NTIS | White Section <input checked="" type="checkbox"/> |
| DDC | Buff Section <input type="checkbox"/> |
| UNANNOUNCED | <input type="checkbox"/> |
| JUSTIFICATION | |
| PER FORM 50 | |
| BY _____ | |
| DISTRIBUTION/AVAILABILITY CODES | |
| Dist. AVAIL. and/or SP. CIAL. | |
| A | |

LIST OF ILLUSTRATIONS

| <u>Figure</u> | | <u>Page</u> |
|---------------|---------------------------------------------------------|-------------|
| 1 | Block Diagram--Configuration 1 | 8 |
| 2 | Block Diagram--Configuration 2 | 10 |
| 3 | Bandpass Crystal Filter Response Curve | 14 |
| 4 | Block Diagram--Initial Breadboard Circuit | 15 |
| 5 | Block Diagram--Second Breadboard Circuit | 16 |
| 6 | SwRI RF Cancellation Circuit | 19 |
| 7 | Block Diagram--Final Cancellation Circuit | 20 |
| 8 | Block Diagram--Phase and Amplitude Matching Circuit | 23 |
| 9 | Control Circuit Schematic | 24 |
| 10 | Block Diagram--Trasceiver Interface | 27 |
| 11 | Modification to Receiver No. 2 Shield | 30 |
| 12 | Test Site with Coast Guard Antenna | 31 |
| 13 | Transceiver and Test Instruments at Field Test Facility | 32 |
| 14 | Proposed Production RF Cancellation Circuit | 40 |
| 15 | Block Diagram--Production RF Cancellation Assembly | 42 |
| 16 | Block Diagram--RF Assembly A1 | 43 |
| 17 | Block Diagram--RF and Logic Assembly | 44 |

LIST OF TABLES

| <u>Table</u> | | <u>Page</u> |
|--------------|-------------------------------------------------------------------------|-------------|
| 1 | Commercially Available RF Components | 4 |
| 2 | Candidate Component Measured Parameters | 12 |
| 3 | RF Cancellation Test Data | 17 |
| 4 | Truth Table for Control Circuit Logic | 25 |
| 5 | Wild Card Module Connections | 26 |
| 6 | Control Cable Interface | 28 |
| 7 | Resistor Values for PI Attenuator | 35 |
| 8 | Radiated Field Strength With and Without the RF Cancellation Circuit | 37 |
| 9 | 20 dB Noise Quieting Test Data | 39 |
| 10 | Material in Installation Kit | 41 |

1.0 PURPOSE

→ The purpose of this research and development program was to develop an optimized method of removing unwanted transmitted signals from the receiver path in a typical Coast Guard VHF FM transceiver station. The circuit developed allows continuous monitoring of the guard channel (Ch. 16, 156.8 MHz) with minimum background interference levels while transmissions are occurring from the same antenna on adjacent channels spaced as close as 150 kHz. The six-month program was divided into four phases:

- (1) ~~Phase 1~~ Components and Circuit Technique Identification and Analysis; This phase consisted of a complete literature search to identify commercially available components and equipment that could be used in the development of the RF cancellation circuit.
- (2) ~~Phase 2~~ Performance Evaluation of Candidate Components and Circuit Techniques; This phase consisted of laboratory testing of candidate components and circuit techniques. The end result of this phase was the development of a viable RF cancellation circuit.
- (3) ~~Phase 3~~ System Field Tests; This phase consisted of system field tests to verify correct operation of the RF cancellation circuit with the Coast Guard transceiver and antenna.
- and (4) ~~Phase 4~~ Specification and Documentation of Program Results. ← This phase consisted of the development of a system specification for an RF cancellation circuit and the generation of this final report.

2.0 INTRODUCTION

The U.S. Coast Guard VHF FM communications base station facilities operated along the coast lines of the United States presently do not comply with the FCC regulations for a public coast station. The FCC regulations for a public coast station require that the guard channel receiver be open and available for reception at all times except when the collocated transmitter is operating on Channel 16. A typical Coast Guard base station facility provides remote controlled transmit-receive on six VHF frequencies in the 156 to 162 MHz range. One transmitter (50 watts output) is utilized for all of the six channels with the specific operating channel (transmit-receive) selected by remote control. Two receivers are utilized with one receiver continuously tuned to the same channel as the transmitter and the other receiver fixed tuned to guard Channel 16 (156.8 MHz).

Presently, when the transmitter is activated, both the guard channel receiver and the selectable channel receiver are muted and automatically disconnected from the antenna to prevent receiver damage. To comply with the FCC regulations, it is necessary that the guard Channel 16 receiver be continuously connected to the transmit-receive antenna and cancellation circuit techniques be employed to reduce the coupled transmitted signal levels into the guard Channel 16 receiver. The unwanted coupled transmitted signal level must be sufficiently attenuated to allow normal or near normal operation of the guard Channel 16 receiver.

3.0 WORK PERFORMED

In order to arrive at both a practical and a satisfactory solution for the required cancellation circuit, it was necessary to describe the set of requirements for the design. These design requirements are:

- (1) Minimum circuit modification to the existing transceiver (Motorola Model C53RTB-1146C-SP2).
- (2) Minimum degradation to the present transmit-only and receive-only system characteristics.
- (3) Maximum attenuation of transmit signals coupled into the guard channel circuit allowing normal or near normal guard channel receiver operation. It was a design goal to attenuate the power coupled from the transmitter to the guard receiver by 100 dB to 150 dB.
- (4) Minimum periodic maintenance requirements for the RF cancellation circuit.
- (5) Maximum reliability under the temperature and humidity conditions specified in EIA Standard No. RS-204-A, "Minimum Standards for Land Mobile Communication FM or PM Receivers, 25-470 MHz."
- (6) Maximum use of commercially available electronic components in the design of the RF cancellation circuit.

3.1 Component and Circuit Technique Identification and Analysis

A detailed search of catalog information describing commercially available devices capable of meeting the design requirements was performed. This search included such devices as band reject and bandpass duplexers, notch filters, bandpass cavities, broadband isolators, multicouplers, and other devices. Table 1 lists the companies and the devices they manufacture that were investigated during the literature search.

The literature search located commercially available equipment that was capable of providing up to 95 dB of attenuation for a transmitter frequency 300 kHz or more from the receiver frequency. This equipment was also capable of high power, typically 200 to 500 watts. The equipment

TABLE 1

COMMERCIALY AVAILABLE RF COMPONENTS

| Manufacturer | Components |
|------------------------------------------|------------------------------------------------------------------------------------------------|
| 1. Addington Laboratories | Broadband Low Frequency Isolators |
| 2. Decibel Products, Inc. | Ferrite Circulators Ferrite Isolators Bandpass Duplexers Band Reject Duplexers |
| 3. Premier Microwave Corp. | Ferrite Devices RF Circulators |
| 4. RCA Commercial | AM-FM Antenna Isolation Units |
| 5. Raytheon Company | UHF Isolators UHF Circulators Duplexers |
| 6. Sonoma Engineering and Research, Inc. | Miniature Circulators |
| 7. Trak Microwave Corp. | Circulators Isolators |
| 8. Alltaire Corp. /Telonic | Cavity Bandpass Filters Miniature Bandpass Filters Tunable Bandpass Filters |
| 9. ARRA, Inc. | Coaxial Bandpass Filters |
| 10. Cirqtel, Inc. | Harmonic Rejection Filters Bandpass Filters Tunable Bandpass Filters Low Pass Filters |
| 11. Granger Associates | HF Transmitting Multicouplers |
| 12. Harris Gates Division | VHF Notch Diplexers |
| 13. RF Communications, Inc. | Preselector and Protection Unit |
| 14. Microphase Corp. | Broadband Multiplexers |
| 15. Microwave Development Corp. | Multiplexers |
| 16. Microwave Filters Co., Inc. | VHF Adjacent Channel Bandpass Filters VHF Diplexers and Triplexers |

TABLE 1
COMMERCIALLY AVAILABLE RF COMPONENTS (CONT)

| <u>Manufacturer</u> | <u>Components</u> |
|-------------------------------|------------------------------------------------------------------|
| 17. Phelps Dodge Industries | Cavity Resonators Duplexers |
| 18. Sinclair Radio | Duplexers |
| 19. Merrimac Industries, Inc. | Directional Couplers |
| 20. Bendix Microwave Corp. | Directional Couplers |
| 21. Arvin Industries, Inc. | Directional Couplers |
| 22. North American Phillips | RF Circulators |
| 23. K & L Microwave, Inc. | Tubular Bandpass Filters |
| 24. Micro Lab/FXR | Bandpass Filters |
| 25. RLC Electronics, Inc. | Tubular Bandpass Filters |
| 26. Texscan Corp. | Cavity Bandpass Filters |
| 27. Piezo Technology, Inc. | Crystal Bandpass Filters |
| 28. Oak Industries, Inc. | Crystal Filters |
| 29. Watkins-Johnson Company | Reactive Power Dividers |
| 30. Wavecom Industries | Directional Couplers |
| 31. Filtech Corporation | Crystal Filters |
| 32. American Nucleonics Corp. | Interference Cancellation Systems Jamming Suppression Systems |
| 33. Narda Microwave Corp. | Couplers |
| 34. Anaren Microwave, Inc. | Passive Couplers and Dividers |

did not meet the frequency spacing requirements of this program. Furthermore, the mechanical size of the equipment was rather large, with typical weights in excess of 200 pounds. No commercially available systems were found that meet all the requirements of the Coast Guard.

The "Science Abstract, Series B, Electrical and Electronics Abstracts" were reviewed in the following subject areas:

- (1) Circulators
- (2) Communications Network
- (3) Couplers and Junctions
- (4) Data Transmission Systems
- (5) Directional Couplers
- (6) Frequency Division Multiplexing
- (7) Interference
- (8) Multiplexing
- (9) Radio Applications
- (10) Telecommunications
- (11) Transmission Networks

The search did not provide any significant articles regarding the design or development of the required RF cancellation circuit under these subject headings.

Since no commercially available components or proven circuit techniques existed that met all the design requirements for the RF cancellation circuit, a design study was undertaken to determine the feasibility of constructing an RF circuit to meet these requirements.

3.2 Performance Evaluation of Candidate Components and Circuit Techniques

Two methods of achieving the desired transmit signal rejection were analyzed to evaluate their potential effectiveness. As part of the analysis, the theoretically derived electrical component requirements were compared to the specifications of commercially available components. One of the primary requirements of the design was to use as many commercially available components as possible. Each candidate circuit was analyzed with respect to each of the design requirements.

3.2.1 Configuration 1 Description

The first RF cancellation circuit theoretically analyzed would utilize monolithic crystal filters to provide attenuation of the unwanted transmitter signal for the guard receiver. In the block diagram shown

in Figure 1, the transmitter output signal (P_T) at 47 dBm (50 watts) is connected to a ferrite circulator which provides a through path for the transmitted power and a return path for the reflected signal plus desired 156.8 MHz signal from the antenna to the receivers. The expected power loss through the ferrite circulator is .5 dB and through the harmonic filter is another .5 dB so that the transmitted signal level into the antenna would be 46 dBm.

Assuming the VSWR at the antenna is approximately 1.5:1 (return loss of 14 dB) the RF power (P_R) reflected back from the antenna would be 32 dBm (1.6 watts). The desired 156.8 MHz (P_{16}) received signal would be present along with this reflected signal. The reflected signal and the 156.8 MHz signal are fed through the harmonic filter (.5 dB loss) and circulator (.5 dB loss) to the two-way power divider (3.5 dB loss). The input to the power divider would then consist of the following signals:

- (1) Reflected power from the antenna, $P_R = 31$ dBm.
- (2) 156.8 MHz RF power $P_{16} = -1.0$ dB (referenced to the antenna's output level).

The power divider splits the signals between the guard Channel 16 receiver and the channelized receiver. The channelized receiver would be in the circuit whenever the transceiver is in a standard receive mode. When the transceiver is in a transmit mode at any frequency, the input to the channelized receiver would be terminated into 50 ohms. The guard Channel 16 receiver would be connected at all times unless the transceiver is transmitting on 156.8 MHz. With the transceiver transmitting on 156.8 MHz, the input line to the guard channel receiver would also be terminated into 50 ohms.

The input to the monolithic crystal filter No. 1 would then be a signal consisting of the reflected power from the antenna at 27 dBm (500 milliwatts) and the 156.8 MHz signal at -5 dB. The monolithic crystal filter No. 1 should provide 60 dB of attenuation for signals more than 30 kHz from its center frequency, 156.8 MHz. The monolithic crystal filter should also have a maximum insertion loss of 6 dB in the passband. The output of this crystal filter is then a signal composed of the reflected power of the antenna at -33 dBm (500 nW) and the 156.8 MHz signal at -11 dB. A 12 dB amplifier would be used to increase the signal level to the guard channel receiver. The output of the amplifier would be a signal composed of the reflected signal from the antenna at -21 dBm (8 μ W) and the guard Channel 16 receiver signal at +1.0 dB. Monolithic crystal filter No. 2 would provide additional passband filtering to cancel the undesired

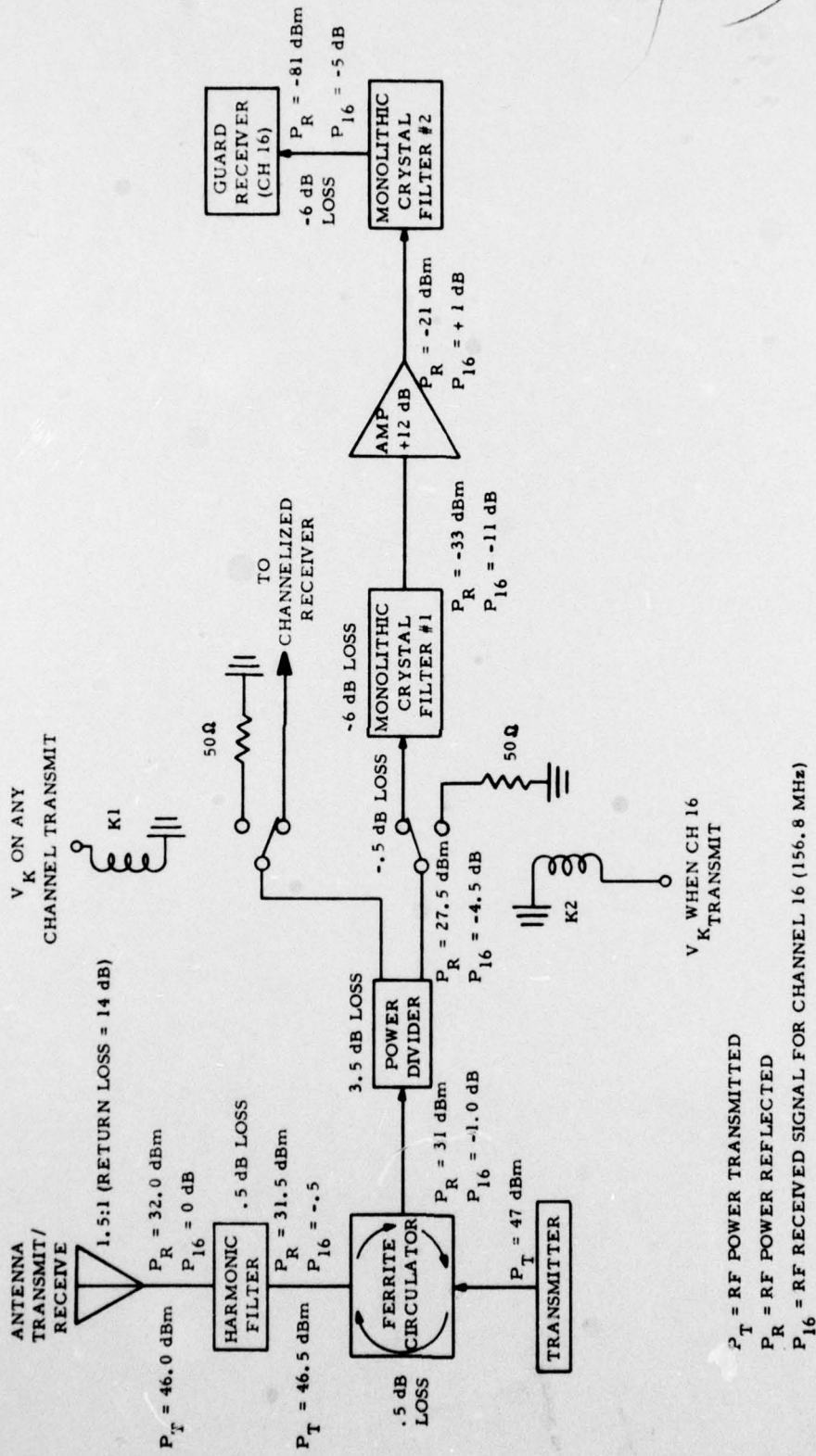

FIGURE 1. BLOCK DIAGRAM--CONFIGURATION 1

signal. This device would provide another 60 dB of attenuation for the reflected signals. The output of this device is then composed of the reflected signal of the antenna at a calculated -81 dBm (total reduction of 128 dB in signal level) and the 156.8 MHz signal at a calculated -5 dB.

The analysis of this circuit indicates that monolithic crystal filter No. 1 must be capable of handling 27 dBm (500 mW) of continuous RF power from the out-of-band reflected signal. The literature search of commercially available crystal filters indicated they are typically capable of handling a maximum of only 10 dBm (10 mW). Because of this, it was decided to abandon this technique and to investigate another method of achieving the RF cancellation.

3.2.2 Configuration 2 Description

The second cancellation technique theoretically analyzed would use an out-of-phase power combiner to cancel the majority of the reflected power from the antenna by combining it with a portion of the transmitter's forward power (see Figure 2). The output of the transmitter (P_T) at 47 dBm (50 W) would be fed to a 20 dB directional coupler. This RF coupler would split the transmitted signal such that the coupled output is 20 dB below the main line output. The main line loss should be less than .5 dB while the directivity of the coupled output should be at least 25 dB. The main line signal through the device would then be fed through a ferrite circulator and then a harmonic filter to the transmit/receive antenna. The output at this point is calculated to be 45.5 dBm. At the transmit/receive antenna, the VSWR is assumed to be 1.5:1 (14 dB return loss). With this VSWR, the reflected signal (P_R) would be at 31.5 dBm and the 156.8 MHz signal (P_{16}) would be at 0 dB (reference). The reflected and 156.8 MHz signals would then be fed back through the harmonic filter and ferrite circulator to a power divider which would split the signal between the guard channel receiver and the channelized receiver. The power levels calculated at this point are the reflected signal at 27 dBm and the 156.8 MHz signal at -4.5 dB. One output of the power divider would be fed through an RF switch into one input of an out-of-phase power combiner while the other out-of-phase power combiner input would be the sampled transmitter signal coming from the directional coupler. The sampled transmitter signal should be adjusted in amplitude and phase to cancel the reflected signal in the power combiner by at least 40 dB. The total reduction in the unwanted signal would then be a calculated 61 dB. The guard channel signal would be attenuated in the out-of-phase power combiner by only 3.5 dB. The output of the power combiner can then be fed through a crystal bandpass filter with a 6 dB insertion loss and an out-of-band attenuation of 60 dB. The calculated output of the crystal filter would then consist of the 156.8 MHz guard receiver signal at -14.5 dB and the unwanted transmitter signal at -74 dBm (a total theoretical

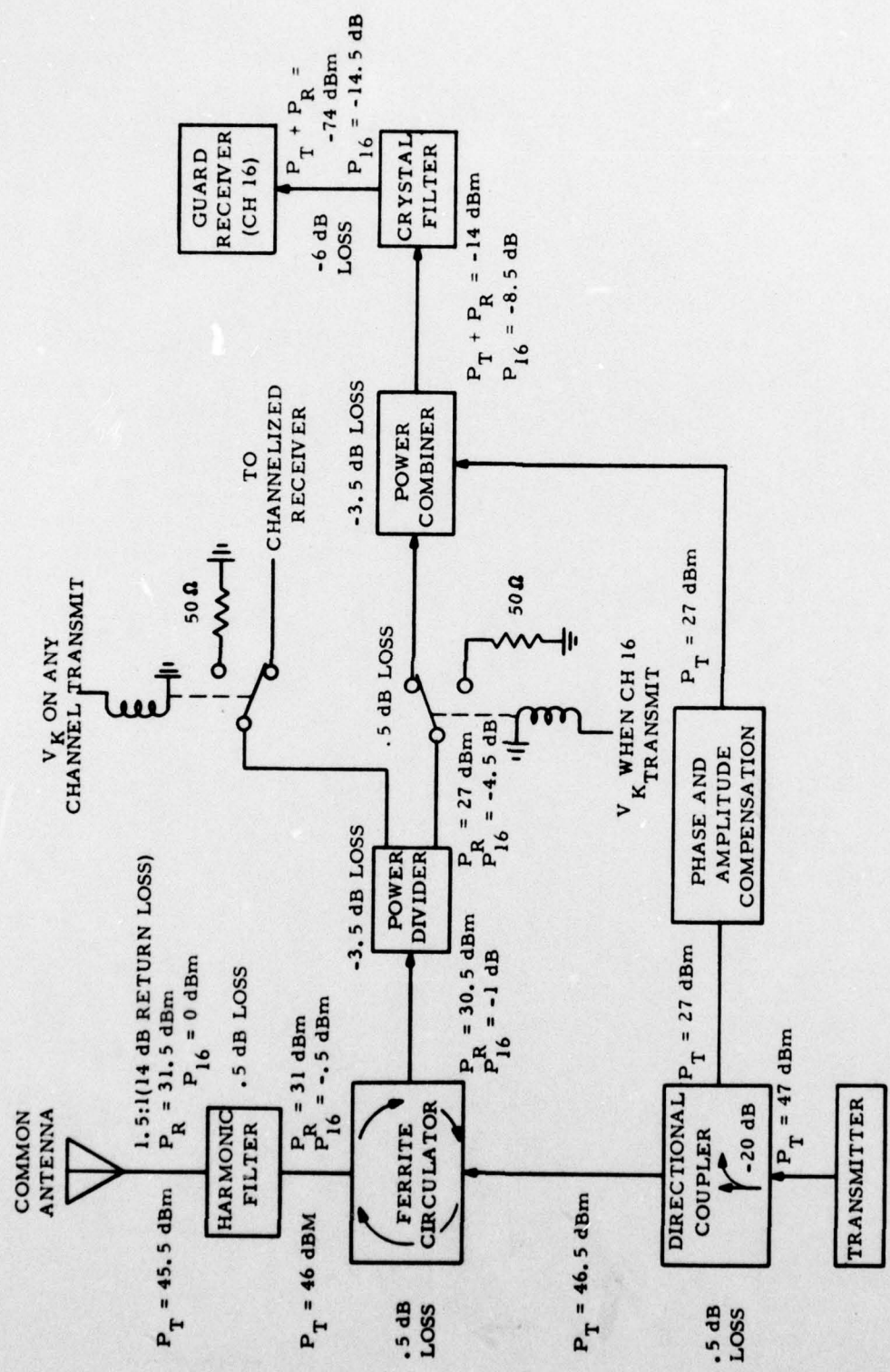

FIGURE 2. BLOCK DIAGRAM--CONFIGURATION 2

reduction of 121 dB in signal level). The guard receiver has a selectivity of 95 dB (30 kHz bandwidth) which further attenuates the effect of the undesired signal to -216 dBm, well below the noise level of approximately -123 dBm.

This circuit meets all the design requirements previously listed. Also, the evaluation of commercially available components indicated that there were components available to meet the requirements of this design. Extensive laboratory tests were conducted on the components necessary for the candidate circuit shown in Figure 2. The evaluation included testing for VSWR, insertion loss, RF cancellation capabilities, and power tests. Table 2 lists the components used in the RF cancellation circuit. This table shows the manufacturer's data sheet specifications for these components and the values measured in the SwRI laboratory tests.

3.2.2.1 Circuit Development

Initial laboratory tests using a simplified phase cancellation technique circuit (shown in Figure 4) showed that a reduction in the unwanted transmitter signal of 46.6 dB at the output of the out-of-phase power combiner could be achieved. A variable air delay line was used to adjust the phase of the reflected signals but no attempt was made to adjust the signal level for optimum cancellation. Though 14 dB short of the calculated cancellation value of 61 dB, these results indicated that the theoretical analysis was valid and that the addition of a variable attenuator to the circuit to allow amplitude matching would allow greater RF cancellation. The first laboratory circuit used the directional couplers, RF circulators, harmonic filters, and power dividers previously tested.

The second generation breadboard cancellation circuit (shown in Figure 5) provided for adjustments in the reflected signal level as well as the sampled transmitter signal level by the addition of variable attenuators in both inputs to the out-of-phase power combiner. The phase adjustment circuit has been relocated into the sampled transmitter signal path. With the phase adjustment located in the sampled transmitter signal path, the circuit is capable of providing cancellation for a wide range of reflected signals. Laboratory tests were conducted with the amplitude/phase adjustment circuit set for maximum cancellation at the guard Channel 16 frequency, 156.8 MHz. The total reduction in unwanted transmitter signal level achieved for the various transmit frequencies was measured to be from 53.6 to 85 dB (see Table 3). These measurements were conducted with the antenna VSWR set at 1:1 (50 ohm). This condition is unlikely to occur in normal field installations due to the impedance mismatch of the antenna.

TABLE 2. CANDIDATE COMPONENT MEASURED PARAMETERS

| Component | Parameter | SwRI Measured Value | Manufacturer's Specifications |
|---------------------------------------------------------------|-------------------------------------|--------------------------|-----------------------------------|
| Crystal Bandpass Filter by Piezo Technology P.N. TM4133 | Center Frequency (f_0) | 156.8 MHz (see Figure 3) | 156.8 MHz |
| | Insertion Loss | 6 dB | 6 dB |
| | Attenuation | -68 dB at ± 15 kHz | -20 dB |
| | $f_0 \pm 30$ kHz $f_0 \pm 60$ Hz | -99 dB | -45 dB |
| Out-of-Phase Power Combiner by Merrimac P.N. PDX-20-200 | Coupling | -3.7 dB at J1 | -3 dB (+.75 dB insertion loss) |
| | Isolation | -3.8 dB at J2 | 25 dB |
| | VSWR | 37.3 dB | 1.3:1 |
| | Phase Balance | 1.143:1 | 180° ($\pm 1^\circ$) |
| | Amplitude Balance | 178° | .2 dB |
| Variable Attenuator by Merrimac P.N. AB-27-160 | Insertion Loss (min) | .5 dB | 1 dB |
| | Power (dc) | 123 ma at +12 Vdc | 120 ma at +15 Vdc |
| Amplifier by Q-bit P.N. QB-300 | Gain | 22.3 dB | 22 dB |
| | VSWR | 1.17:1 | 1.5:1 |
| | Input Output | 1.11:1 | 1.5:1 |
| RF Circulator by Decibel Products P.N. DB-4315 | Insertion Loss | .5 dB | .6 dB |
| | VSWR | 1.22:1 | 1.25:1 (max) |
| | Isolation | 19.5 dB (min) | 25 dB (min) |

TABLE 2. CANDIDATE COMPONENT MEASURED PARAMETERS (CONT)

| Component | Parameter | SwRI Measured Value | Manufacturer's Specifications |
|-----------------------------------------------------|----------------------------------------------|---------------------|-------------------------------|
| Directional Coupler by Narda P.N. 3039-20 | Insertion Loss Coupling | .1 dB | .2 dB |
| | | -20.5 dB | -20 ± .5 dB |
| Harmonic Filter by Decibel Products P.N. DB-4331 | VSWR Insertion Loss | 1.19 | 1.25:1 |
| | | .2 dB at 156.8 MHz | .2 dB |
| Limiter by AEL P.N. MIC-3175-1 | VSWR Insertion Loss Leakage | 1.1:1 | 1.2:1 (typ) |
| | | .1 dB | .5 dB (max) |
| | | 16 mW | 100 mW |
| Phase Shifter by Merrimac P.N. PS-3-160 | VSWR Insertion Loss | 1.4:1 | 1.5:1 |
| | | .6 dB | 1 dB |
| Relay SPDT by Diaco P.N. 100C0413-12 | VSWR Insertion Loss | 1.14:1 | 1.4:1 |
| | | .37 dB | .3 dB |
| | Isolation Power | 72 dB-NO; 63 dB-NC | 50 dB (min) |
| | | 20 ma at 12 Vdc | 28 ma at 12 Vdc |
| Relay SP5T by Diaco P.N. 100C0604-12 | VSWR Insertion Loss Isolation Power | 1.17 | 1.5:1 |
| | | .2 | .25.3 dB (max) |
| | | 50 to 65 dB | 55 dB (min) |
| | | 21 ma at 12 Vdc | 24 ma at 12 Vdc |

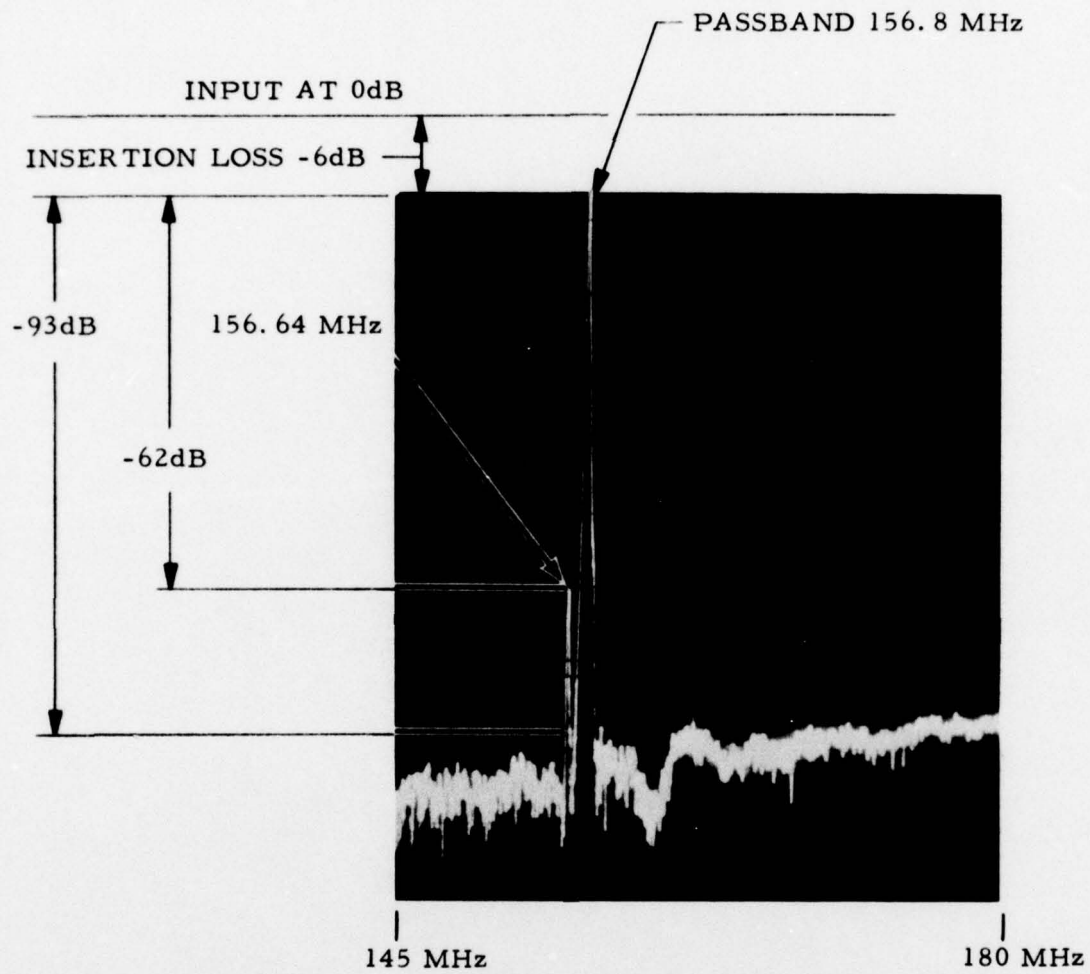

FIGURE 3

BANDPASS CRYSTAL FILTER RESPONSE CURVE

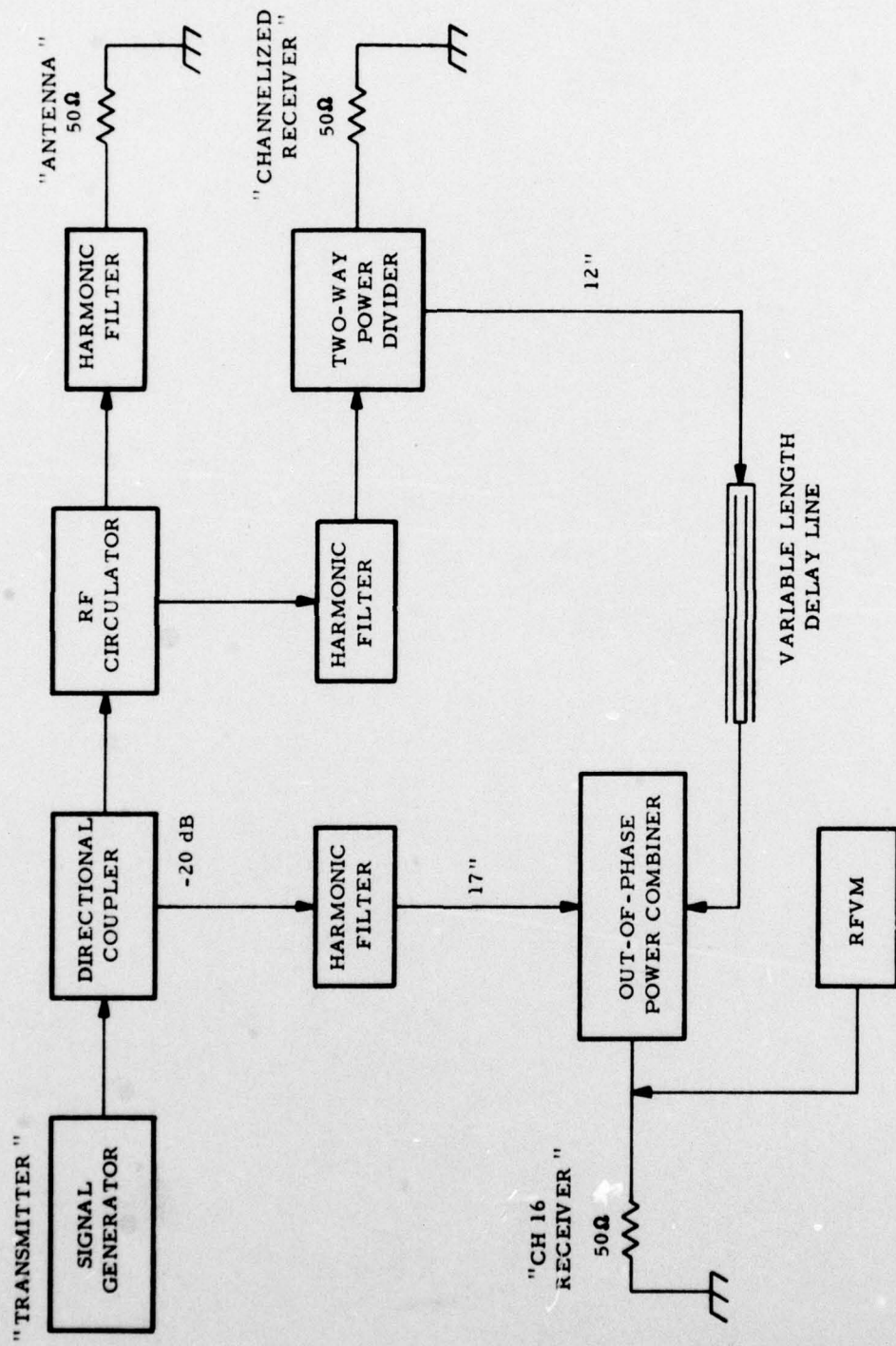

FIGURE 4. BLOCK DIAGRAM--INITIAL BREADBOARD CIRCUIT

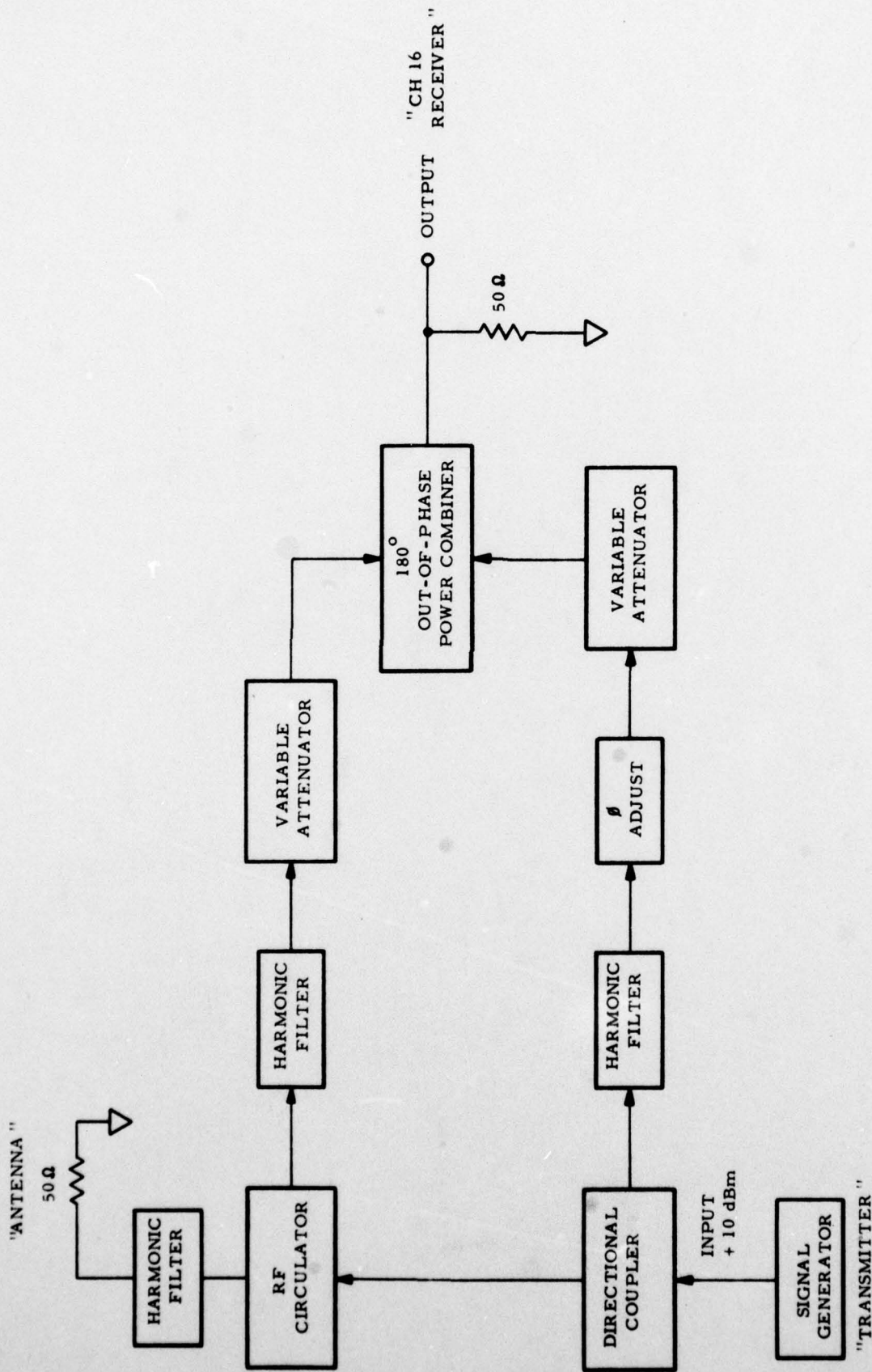

FIGURE 5. BLOCK DIAGRAM--SECOND BREADBOARD CIRCUIT

TABLE 3
RF CANCELLATION TEST DATA

| <u>Test Conditions</u> | <u>Frequency (MHz)</u> | <u>Simulated Antenna VSWR</u> | <u>Attenuation at Out-of-Phase Power Combiner (dB)</u> |
|-----------------------------------------------------------|------------------------|-------------------------------|--------------------------------------------------------|
| Phase Shift Set for Maximum Attenuation at 156.8 MHz | 156.5 | 1:1 | 63 |
| | 156.8 | 1:1 | 85 |
| | 157.075 | 1:1 | 57.6 |
| | 157.1 | 1:1 | 53.6 |
| | 157.150 | 1:1 | 55.7 |
| | 157.175 | 1:1 | 55.2 |
| Phase Shift Set for Maximum Attenuation at Each Frequency | 156.65 | 1.12:1 | >90 |
| | 156.8 | 1.12:1 | >90 |
| | 157.075 | 1.12:1 | >90 |
| | 157.1 | 1.12:1 | 85 |
| | 157.150 | 1.12:1 | >90 |
| | 157.175 | 1.12:1 | >90 |
| Phase Shift Set for Maximum Attenuation at Each Frequency | 156.65 | 1.24:1 | >90 |
| Phase Shift Set for Maximum Attenuation at Each Frequency | 156.65 | 1.5:1 | >90 |

The simulated antenna VSWR was increased to 1.12:1 and the amplitude/phase adjustment circuit was adjusted for maximum cancellation at each transmit frequency. Using this technique, attenuation of the unwanted RF signal at the output of the out-of-phase power combiner was greater than 85 dB for all frequencies (see Table 3), well beyond the 61 dB previously calculated. As the impedance mismatch of the simulated antenna was increased to 1.5:1, the attenuation for all transmit frequencies remained greater than 90 dB. The amount of cancellation achieved indicated there would be no problems of over driving the bandpass crystal filter needed with the configuration 2 circuit. Indeed, a 40 dB margin of safety existed. The results of the test indicated that this cancellation technique was a viable method to achieve the desired results. It also showed that it would be necessary to provide phase and amplitude adjustments for each transmit frequency in order to achieve the desired results.

In the final test circuit, the output of the out-of-phase power combiner was fed through a limiter before going to the newly acquired crystal bandpass filter to protect it against any transients which might occur. This filter provided more than 60 dB of additional attenuation for signals greater than 30 kHz from 156.8 MHz. At the output of the crystal filter, the unwanted transmit signals have been attenuated a total of 150 dB. Since the crystal bandpass filter also attenuates the desired signal 6 dB, a low noise 22 dB gain broadband amplifier was added to increase the 156.8 MHz signal level and thus improve the sensitivity of the guard Channel 16 receiver. Total cancellation of the unwanted transmit signal has thus been reduced 128 dB. The remaining -81 dBm of unwanted signal is easily handled by the guard Channel 16 receiver's 95 dB selectivity. Indeed, the signal is effectively at -176 dBm, 53 dB below the noise level.

3.2.2.2 Final Circuit Description

The final RF cancellation circuit is shown in Figure 6 with a block diagram shown in Figure 7. When the transmitter is not activated, signals received by the antenna are routed through the existing receiver coupler into both the channelized receiver and to the guard Channel 16 receiver, thus providing original system sensitivity. Whenever the transmitter is activated on any channel except 16, the power to the channelized receiver is switched off and the input to the guard receiver is provided by the cancellation circuit through the receiver relay. Whenever the transmitter is activated on Channel 16, the guard receiver remains connected to the receiver coupler. A detailed description of the operations of the cancellation circuit is given below.

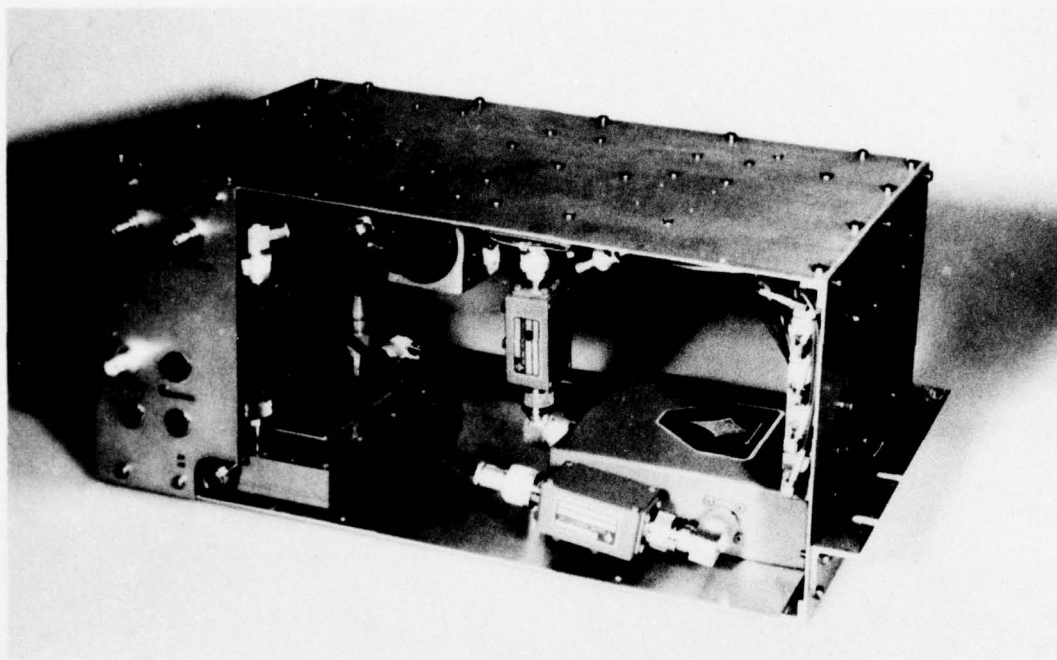

a. Top View with Cover Removed

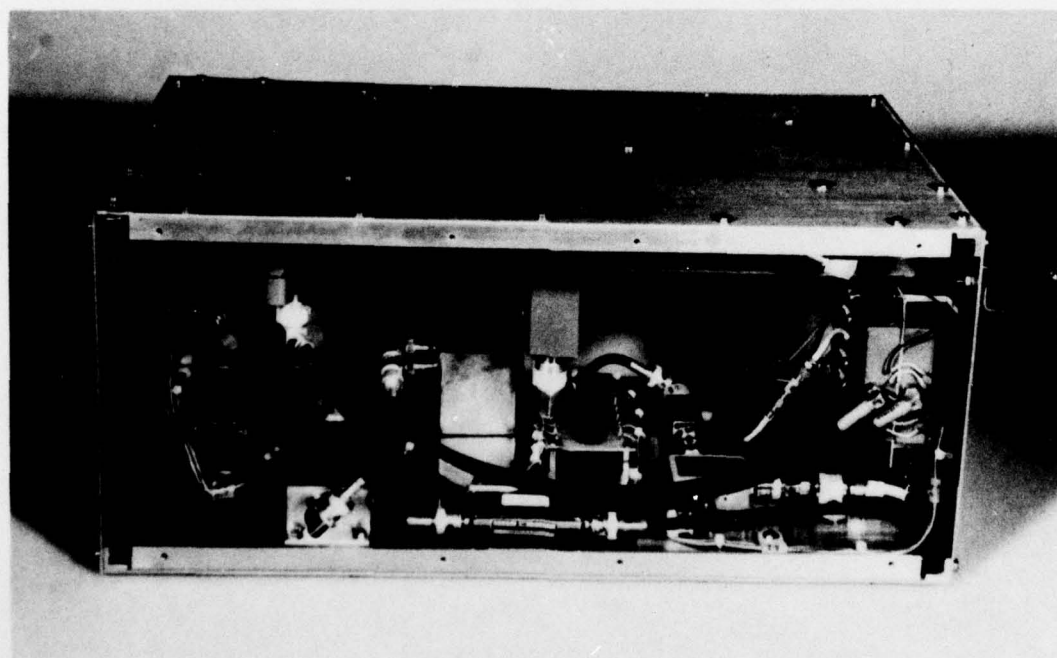

b. Bottom View with Cover Removed

FIGURE 6. SWRI RF CANCELLATION CIRCUIT

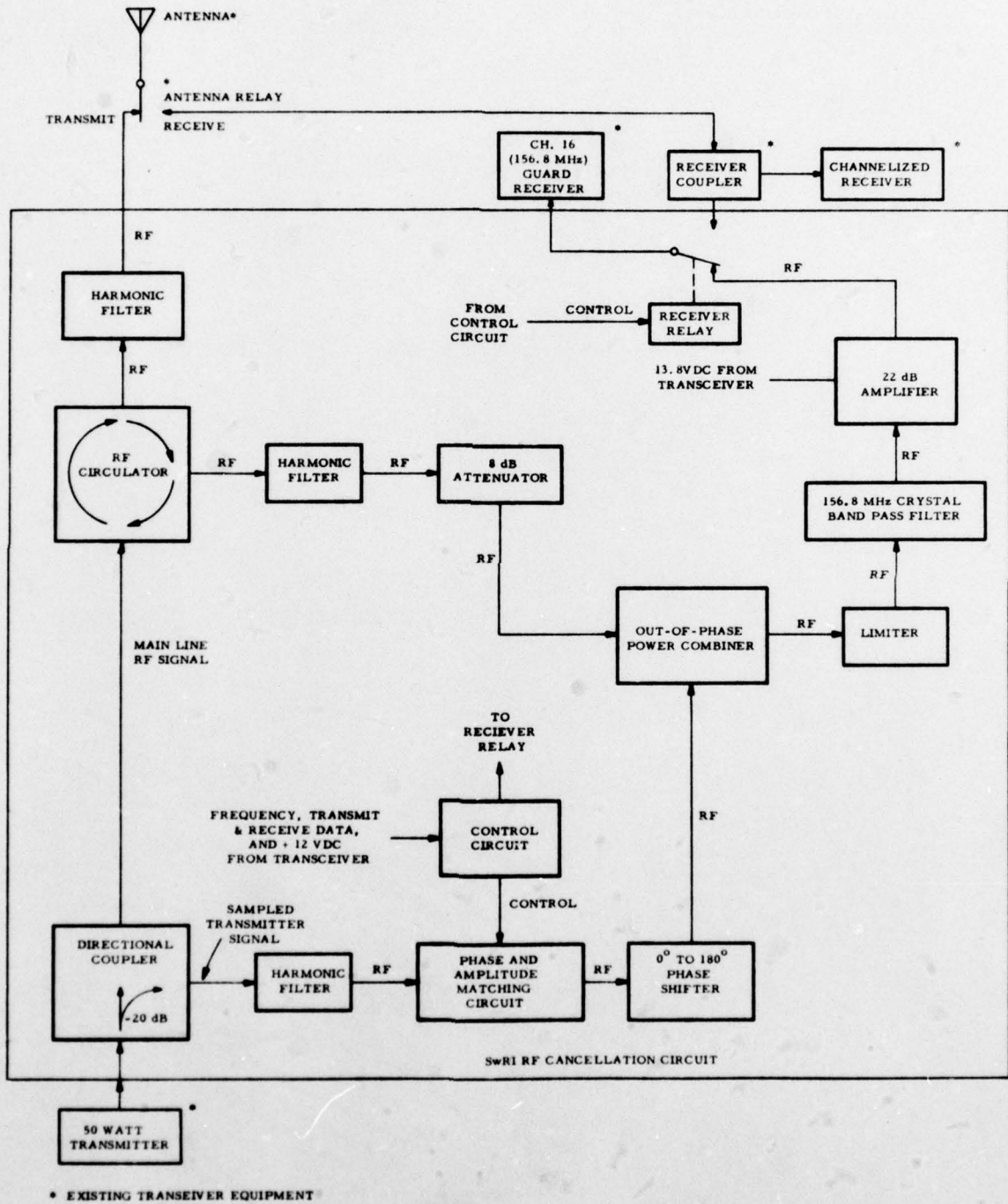

FIGURE 7. BLOCK DIAGRAM--FINAL CANCELLATION CIRCUIT

Power from the transmitter is routed to the 20 dB directional coupler which splits the transmitted signal into two parts. The sampled transmitter output is 20 dB below the main line output signal (which has a loss of only .1 dB). The sampled transmitter signal is fed through a harmonic filter to suppress any harmonics present in the transmitter output which might interfere with the cancellation process. The output of the harmonic filter is fed to the phase and amplitude matching circuit. The phase and amplitude matching circuit and the 0° to 180° phase shifter provide a signal to the out-of-phase power combiner that is in phase with the signal reflected from the antenna and of equal amplitude. The phase and amplitude matching circuit provides separate attenuators and delay lines for each of the five unwanted transmitted frequencies. The proper phase and amplitude matching circuit is selected by the control circuit dependent upon the frequency.

The main line RF signal from the directional coupler is fed to an RF circulator which separates this forward signal from the signal reflected from the antenna. Again, harmonic filters are provided on all outputs of the RF circulator to suppress any harmonics which are present in the transmitter's output or which may have been generated by the ferrite circulator itself. The main line output is fed to the existing antenna relay, then to the antenna. The antenna VSWR of approximately 1.3:1 results in a reflected signal of approximately .6 watt (28 dBm). Combined with this reflected signal is the desired 156.8 MHz signal. These signals are fed through the harmonic filter to the RF circulator where they are coupled to the adjacent output port. Another harmonic filter and an 8 dB attenuator complete the path to the out-of-phase power combiner. The 8 dB attenuator is used to adjust the amplitude of the reflected signal to a level equal to the amplitude of the sampled transmitter signal from the phase and amplitude matching circuit. When the reflected signal and the sampled transmitter signal (which has been phase and amplitude matched) are combined in the out-of-phase power combiner, the resultant attenuation is on the order of 40 to 60 dB. The 156.8 MHz signal passes through the out-of-phase power combiner with only 3.5 dB of loss. The combiner's output is fed through a limiter which provides protection for the crystal bandpass filter. The crystal bandpass filter operates at 156.8 MHz and provides additional attenuation of 60 dB for signals ± 30 kHz or more away from the center frequency. At this point, the unwanted transmitter signals have been attenuated at least 120 dB. The signal is then fed to the 22 dB low noise amplifier to provide for an increase in the sensitivity of the guard Channel 16 receiver. The output of the amplifier is fed to the receiver relay. This relay is activated to connect the guard receiver to the RF cancellation circuit whenever the transmitter is operated at any frequency other than 156.8 MHz. During operation at 156.8 MHz, the relay is not activated and the guard receiver is connected to the antenna coupler.

The phase and amplitude matching circuit (see Figure 8) consists of a pair of SP5T RF relays, delay lines, and attenuators. For each transmitted frequency (excluding 156.8 MHz), a precision delay line and attenuator (shown as "Phase and Amp Circuit") is provided. The delay line is made of RG-316/U cable and is calculated to provide the degree of phase shift required to cause the sampled transmitter signal to be in phase with the reflected signal. A small variable capacitor is included in the attenuator to allow $\pm 6^\circ$ adjustment in the phase. The attenuators are 50 ohm "pi" type made from commercially available standard carbon 5% resistors (1/4 watt). A variable resistor is added to the output for 0 to .5 dB adjustment of the attenuation.

The control circuit consists of four CMOS integrated circuits as shown in Figure 9. The input to the control circuit consists of negative true logic from the transceiver wild card control modules, control voltage from the antenna relay, and +12 Vdc power. The output of the control circuit provides drive current for the phase and amplitude matching circuit and the receiver relay. CMOS integrated circuits were used exclusively in this control assembly because of the extremely low load they place on the wild card modules and their ability to operate over wide supply voltage and temperature ranges.

Since the method by which a phase and amplitude circuit is chosen is essentially the same for each of the five circuits, only one selection will be described here. When a frequency is selected at the transceiver control unit, the wild card module supplies a low level output which is monitored by the control circuit. This low level signal is inverted in one of the CMOS drivers (U2, U3, or U4). The high level output voltage activates the appropriate phase and amplitude circuit by energizing the pair of relays connecting that circuit.

The receiver relay is controlled by inputs received from the antenna relay and the guard channel signal on wild card No. 1. The control circuit provides drive to the receive relay for a transmit condition on any channel except 16.

Table 4 is a truth table which describes the circuit's operation for each state. Table 5 shows the connections between the wild card module and the control circuit.

Figure 10 is a block diagram of the transceiver/cancellation circuit interface, showing the RF and control wiring connections. Table 6 lists the control cable interface connections.

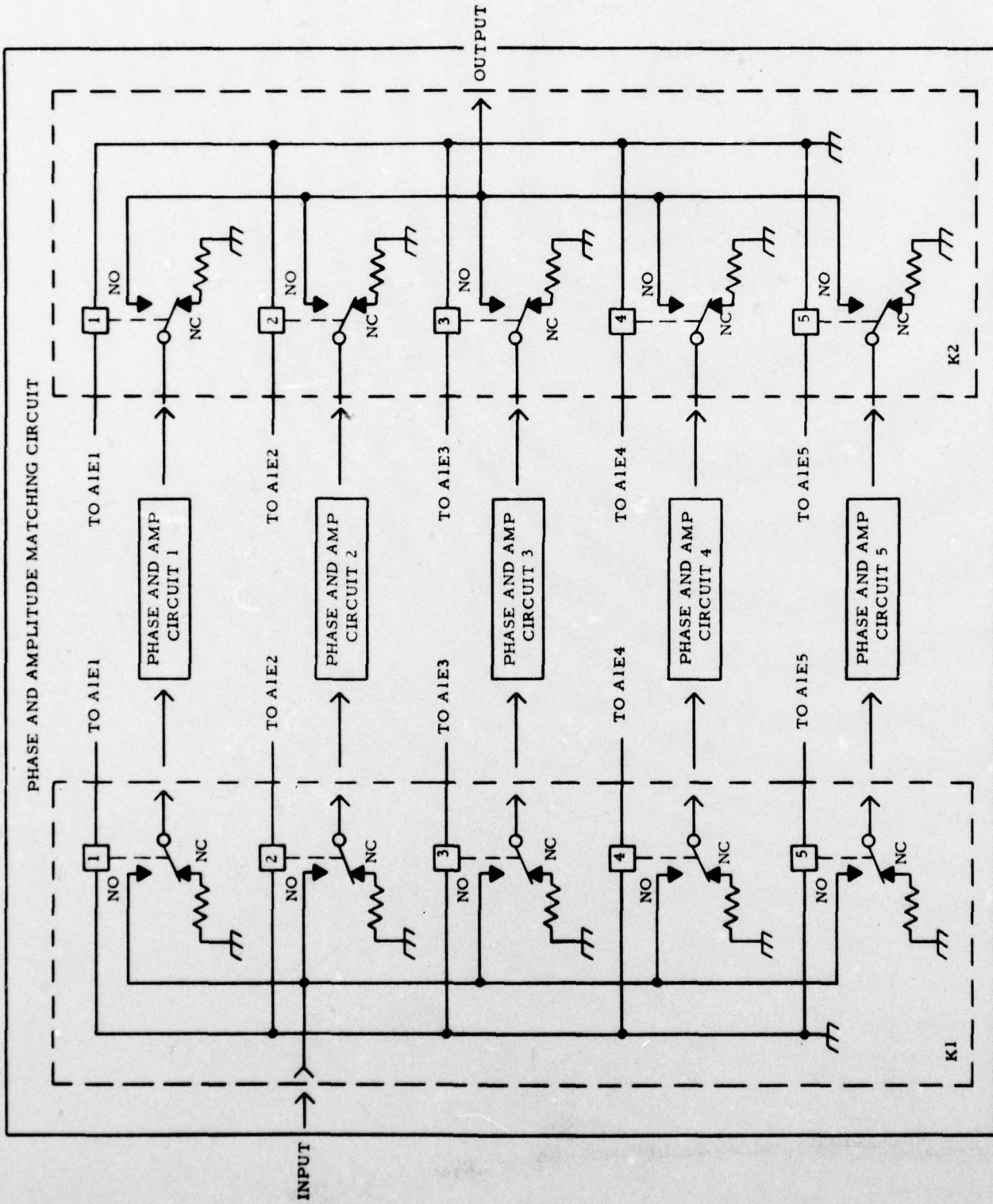

FIGURE 8. BLOCK DIAGRAM--PHASE AND AMPLITUDE MATCHING CIRCUIT

TABLE 4. TRUTH TABLE FOR CONTROL CIRCUIT LOGIC

| States | Antenna Relay Level | Ch. 1* (156.8 MHz) Select Level | Ch. 2** Select Level | To Receiver Relay | To Appropriate Ch. 2-6 Phase and Amplitude Circuit |
|-----------------------------------------------------------------|---------------------|---------------------------------|----------------------|-------------------|----------------------------------------------------|
| 1. Transmitter off. Channelized receiver on Ch. 2 (156.65 MHz). | HI | HI | LO | LO | HI |
| 2. Transmitter keyed on Ch. 2 (156.65 MHz). | LO | HI | LO | HI | HI |
| 3. Transmitter keyed on Ch. 1 (156.8 MHz). | LO | LO | HI | LO | LO |

*Channel numbers given here are Motorola transceiver nomenclature and do not correlate to VHF Marine Band channel numbers.

**Ch. 2 is given as an example. The same logic applies for Channels 3, 4, 5, and 6.

TABLE 5

WILD CARD MODULE CONNECTIONS

| <u>Channel No.</u> | <u>Frequency (MHz)</u> | <u>Wild Card No.</u> | <u>Pin No.</u> | <u>Control Circuit Connection</u> |
|--------------------|----------------------------|----------------------|----------------|---------------------------------------|
| 1 | 156.8 | 1 | 3 | E7 |
| 2 | 156.65 | 1 | 8 | E10 |
| 3 | 157.1 | 1 | 16 | E12 |
| 4 | 157.15 | 1 | 23 | E13 |
| 5 | 157.075 | 2 | 3 | E11 |
| 6 | 157.175 | 2 | 8 | E9 |

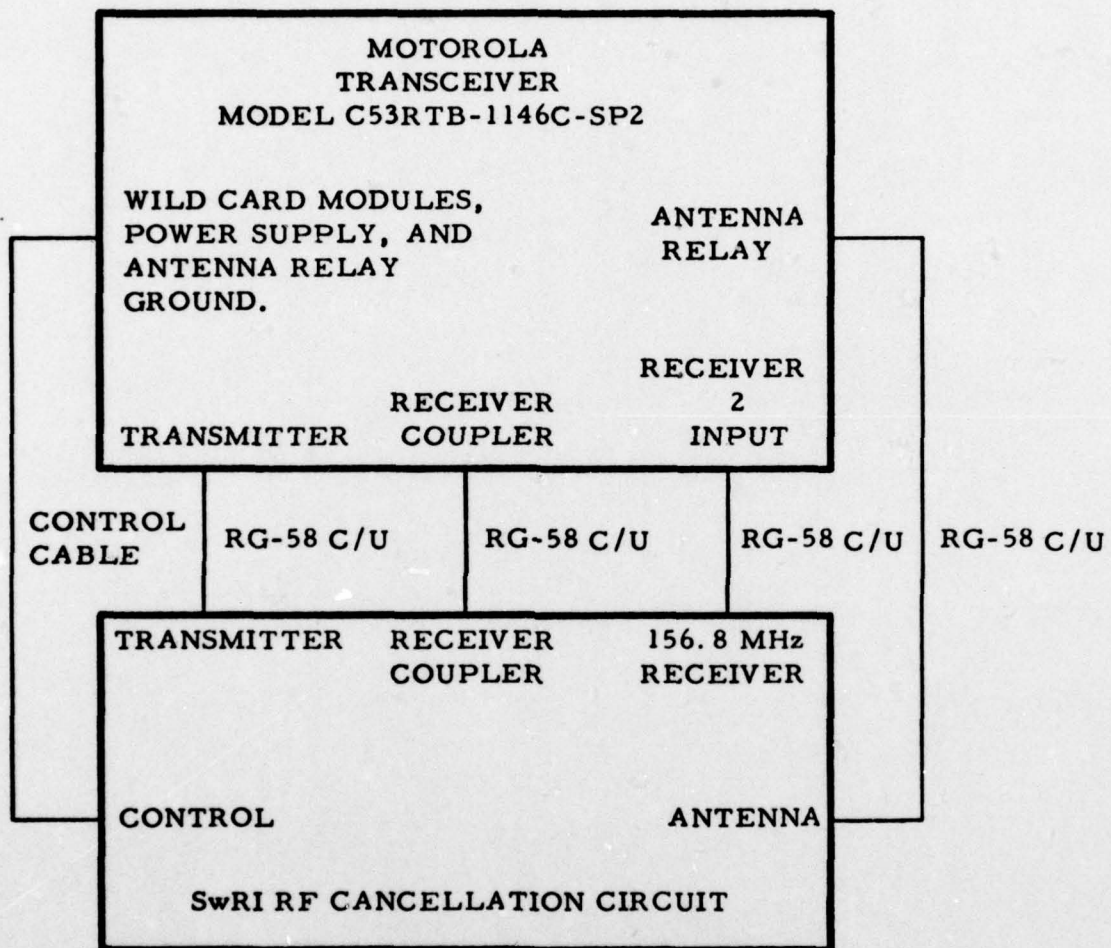

FIGURE 10

BLOCK DIAGRAM--TRANSCEIVER INTERFACE

TABLE 6
CONTROL CABLE INTERFACE

| <u>SwRI Control Connector Pins</u> | <u>Transceiver Connections</u> |
|----------------------------------------|--------------------------------|
| A | Wild Card No. 1, Pin 3 |
| B | Wild Card No. 1, Pin 8 |
| C | Wild Card No. 1, Pin 16 |
| D | Wild Card No. 1, Pin 23 |
| E | Wild Card No. 2, Pin 3 |
| F | Wild Card No. 2, Pin 8 |
| H | Antenna Relay BLK- |
| J | +13.8 Vdc on Power Supply |
| K | +12 Vdc on Power Supply |

A transmitter shield (Motorola part number TLN 1434A) and receiver shield (Motorola part number TLN 1435B) were installed to permit simultaneous operation of the transmitter and guard receiver without RF interference. Modifications were made to the shield on the guard receiver to permit the output of the receiver discriminator (Pin 34) to the 50 conductor interface cable. An RF feed-through consisting of a 1000 pico Farad capacitor and a ferrite bead choke were installed in the shield (see Figure 11). To complete the installation of the shields, receiver back panels (Motorola part number 15-84254D01), captive screws (Motorola part number 3-84141D01), and sheet metal screws (Motorola part number 3-134169) were required.

3.3 System Field Tests

Field tests were conducted at one of the SwRI field test facilities shown in Figure 12. The transmitting antenna was mounted on top of the building with the transceiver placed in a screen room inside (see Figure 13). Field tests were conducted to evaluate the following characteristics of the RF cancellation circuit:

- (1) Attenuation of transmitted signal by the cancellation circuit.
- (2) Level of undesired transmitted signal at the input to the guard Channel 16 receiver.
- (3) Effects of the cancellation circuit on the transmitted power output level as measured by the actual radiated field strength.
- (4) The required incident guard channel signal field strength at the transceiver antenna for 20 dB noise quieting with the cancellation circuit in operation and the VHF FM transceiver transmitting on a channel other than the guard channel.

The initial tests at the field sites showed the necessity of installing the Motorola shields (RF filters) on the GFE transceiver. When the transceiver was in a transmit condition, the RF cancellation circuit and test instrumentation within the screen room were saturated by the RF field from the transceiver. The shields, as previously described, were procured from Motorola to eliminate this problem. Shields will be required for all future installations of the RF cancellation circuit.

After the final configuration was achieved, the phase and amplitude matching circuits were set for maximum cancellation of the transmitted signal at the out-of-phase power combiner's output. Laboratory tests showed that maximum cancellation is achieved by adjusting the phase

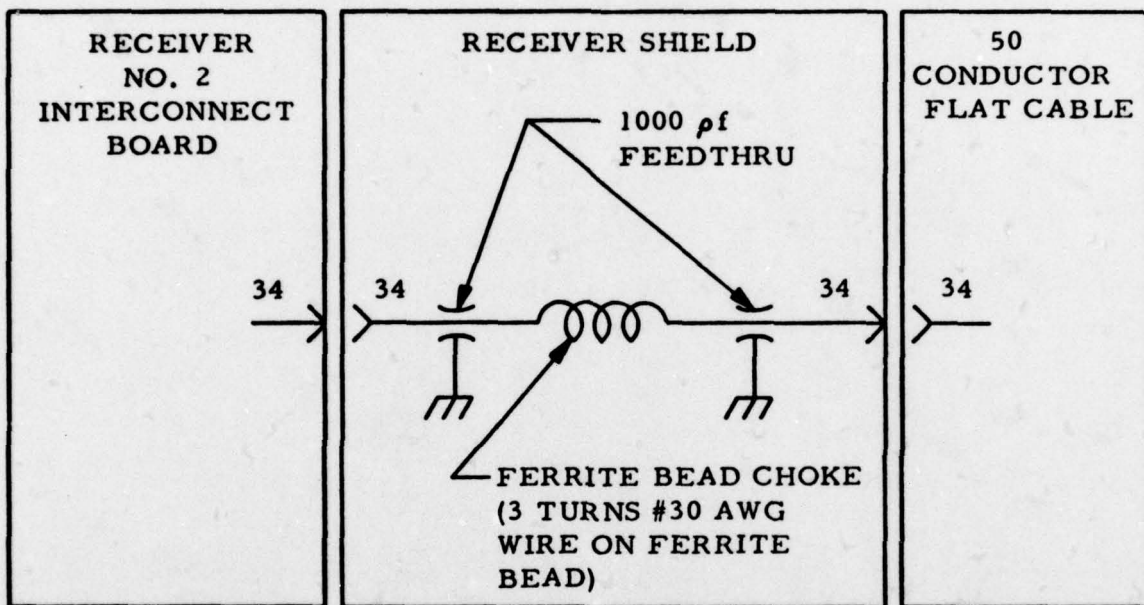

NOTE: FEED-THROUGH CAPACITORS USED WERE JACO Mfg. CO., # EF5-1000.
FERRITE BEADS USED WERE FERRONICS, Inc., # 21-030-F.

FIGURE 11

MODIFICATION TO RECEIVER NO. 2 SHIELD



FIGURE 12. TEST SITE WITH COAST GUARD ANTENNAS

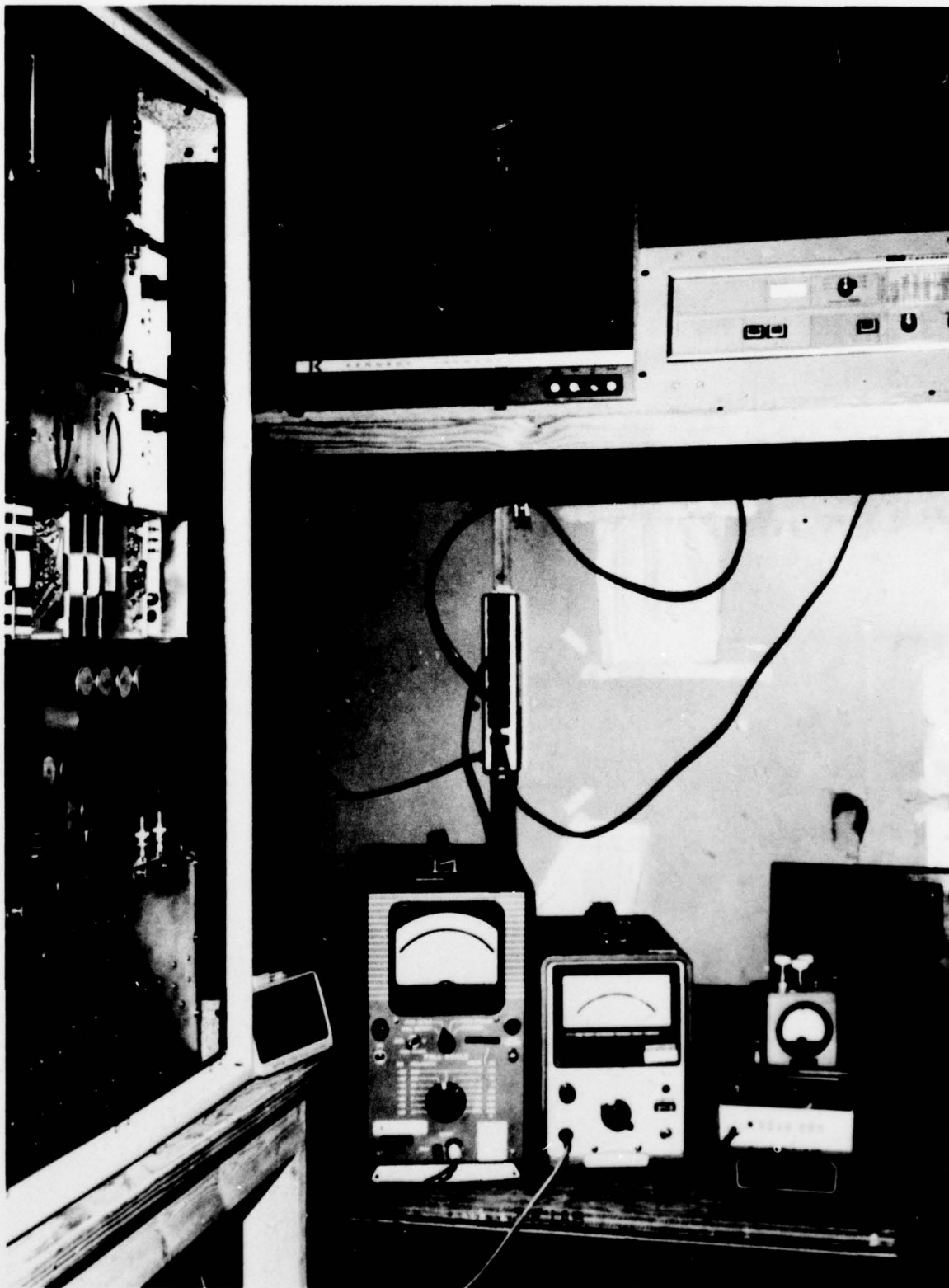

FIGURE 13. TRANSCEIVER AND TEST INSTRUMENTS AT FIELD TEST FACILITY

and amplitude matching circuit for each transmitter frequency. A description of the procedure follows:

- (1) With the transmitter keyed ON, the amplitude and phase (referenced to transmitter output) of the reflected signal was measured at the out-of-phase power combiner's input. This data was recorded for each transmitter frequency.
- (2) The amplitude of the sampled transmitter signal (with no attenuation in the phase and amplitude element) was also measured for each frequency at the input to the out-of-phase power combiner.
- (3) With this data, the required attenuation of the reflected transmitter signal was determined to be 8 dB. The design requires the reflected transmitter signal level to be slightly less than the sampled transmitter signal level. For practical purposes, the reflected signal level should be approximately 1 dB less than the sampled transmitter signal level because the attenuator in the sampled transmitter signal circuit has some minimum insertion loss, approximately .5 dB.
- (4) The phase matching circuitry consists of a delay line (RG-316/U) and a variable phase shifter. The variable phase shifter is set to provide a majority of the required phase shift for all frequencies. The delay lines are designed to provide a smaller fixed increment of phase shift for each frequency. The final phase adjustment for each frequency is provided by the variable capacitor in the amplitude matching attenuators. These capacitors vary the phase $\pm 6^\circ$. At each frequency the phase shift is described by the following equation:

$$\begin{aligned} &\phi_{\text{PHASE SHIFTER}} + \phi_{\text{DELAY LINE}} + \phi_{\text{ATTENUATOR}} (\pm 6^\circ) \\ &= \phi_{\text{TOTAL REQUIRED}} \end{aligned}$$

Note that the phase shifter has a range of $\pm 90^\circ$ and that RG-316/U cable has a delay of $6.93^\circ/\text{inch}$ at 157 MHz (26 in = 180°).

- (5) The last step is to determine the value of the resistors in the attenuator portion of the phase and amplitude matching circuitry. The sampled transmitter signal should be attenuated to a level that is exactly equal to the reflected signal level at the input to the out-of-phase power combiner. The attenuators were constructed using discrete, commercially available carbon resistors. Table 7 is a listing of attenuator values and the commercially available resistors required to construct various attenuators. A small variable resistor and capacitor were provided in each of the attenuators to provide a small amount of phase and gain adjustment.
- (6) With these attenuators in the circuit, the variable resistors and capacitors were fine-tuned at each frequency for maximum cancellation at the out-of-phase power combiner's output.

The attenuation of the transmitted signal by the RF cancellation circuit was measured using an in-line wattmeter to be 1.9 dB. This loss was constant over the entire frequency range of operation (156.65 MHz to 157.175 MHz) and over the entire temperature range of testing. These results closely correspond to the theoretically calculated loss (1.5 dB) of the transmitted signal through the RF cancellation circuit.

The effect of the cancellation circuit on the radiated power was determined by measuring the radiated field strength with the cancellation circuit both in and out of the transmission path. The radiated field strength measurements (see Table 8) show the cancellation circuit attenuates the transmitted signal by less than 1.79 dB. This compares closely with the theoretical attenuation of 1.5 dB and the power attenuation measurement of 1.9 dB.

The maximum level of the undesired transmitter signal at the input to the guard receiver was measured to be -62 dBm (620 picowatts). For the reflected signal of 28.5 dBm (.7 watts) at the antenna, this represents a level that is 88.5 dB below the reflected signal and thus a total cancellation of 109 dB for the 50 watt transmitted signal. With a receiver selectivity of -95 dB (30 kHz bandwidth), the undesired signal is effectively attenuated 204 dB.

The received field strength required for 20 dB noise quieting in the guard Channel 16 receiver was measured with the transceiver transmitting on each of its frequencies. For each transceiver frequency, the transmitter was keyed "on" while the portable target transmitter radiated a signal at 156.8 MHz. The audio noise output level was monitored at the

TABLE 7
RESISTOR VALUES FOR PI ATTENUATOR

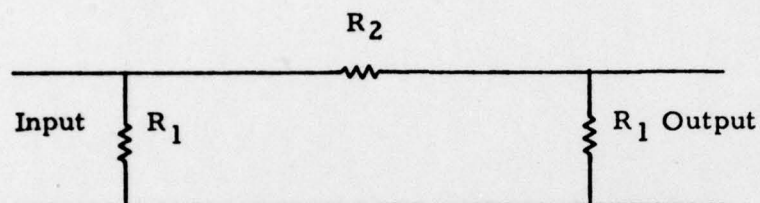

All resistors are carbon compositions, 5% tolerance.

| <u>Attenuation</u> <u>(dB)</u> | <u>Impedance</u> <u>(Ohms)</u> | <u>R₁</u> <u>(Ohms)</u> | <u>R₂</u> <u>(Ohms)</u> |
|-----------------------------------|-----------------------------------|---------------------------------------|---------------------------------------|
| .20 | 49.8 | 4320 | 1.15 |
| .31 | 50 | 2870 | 1.74 |
| .40 | 49.9 | 2150 | 2.32 |
| .50 | 49.9 | 1740 | 2.87 |
| .59 | 50.5 | 1470 | 3.48 |
| .70 | 48.5 | 1200 | 3.9 |
| .80 | 50.8 | 1100 | 4.7 |
| .90 | 50.4 | 976 | 5.23 |
| 1.0 | 53 | 910 | 6.2 |
| 1.1 | 55.5 | 910 | 6.8 |
| 1.36 | 64.2 | 910 | 9.1 |
| 1.96 | 48.3 | 430 | 11 |
| 2.1 | 52.5 | 430 | 13 |
| 2.3 | 56.3 | 430 | 15 |
| 3.0 | 51.2 | 300 | 18 |
| 3.3 | 56.4 | 300 | 22 |
| 3.5 | 53.4 | 220 | 22 |
| 4.0 | 50.0 | 220 | 24 |
| 4.3 | 52.9 | 220 | 27 |

TABLE 7
RESISTOR VALUES FOR PI ATTENUATOR (CONT)

| <u>Attenuation</u> (dB) | <u>Impedance</u> (Ohms) | <u>R₁</u> (Ohms) | <u>R₂</u> (Ohms) |
|----------------------------|----------------------------|--------------------------------|--------------------------------|
| 5.0 | 49.9 | 180 | 30 |
| 5.2 | 52.2 | 180 | 33 |
| 5.9 | 49.1 | 150 | 36 |
| 6.1 | 50.9 | 150 | 39 |
| 6.4 | 53.1 | 150 | 43 |
| 6.7 | 55.2 | 150 | 47 |
| 6.9 | 49 | 130 | 43 |
| 7.2 | 50.9 | 130 | 47 |
| 7.5 | 52.6 | 130 | 51 |
| 7.7 | 50.2 | 120 | 51 |
| 7.8 | 54.7 | 130 | 56 |
| 8.1 | 52.2 | 120 | 56 |
| 8.5 | 54.4 | 120 | 62 |
| 8.8 | 51.6 | 110 | 62 |
| 9.2 | 53.5 | 110 | 68 |
| 9.6 | 50.4 | 100 | 68 |

TABLE 8
RADIATED FIELD STRENGTH WITH AND WITHOUT THE
RF CANCELLATION CIRCUIT

| <u>Channel</u> | <u>Frequency (MHz)</u> | <u>Radiated Field Strength ($\mu\text{V}/\text{m}$)</u> | | <u>Cancellation Circuit Attenuation (dB)</u> |
|----------------|----------------------------|--------------------------------------------------------------------|-------------------------------------------------|----------------------------------------------------------|
| | | <u>With the Cancellation Circuit</u> | <u>Without the Cancellation Circuit</u> | |
| 1 | 156.8 | 7943 | 9772 | 1.79 |
| 2 | 156.65 | 8601 | 10000 | 1.30 |
| 3 | 157.1 | 7673 | 8609 | .99 |
| 4 | 157.15 | 7161 | 8222 | 1.20 |
| 5 | 157.075 | 7767 | 8709 | 1.00 |
| 6 | 157.175 | 7161 | 7943 | .90 |

guard Channel 16 receiver as the radiated field from the portable transmitter was increased until the noise was quieted by 20 dB. Table 9 shows the 20 dB noise quieting data. The sensitivity of the guard receiver is degraded by an average of 5.68 dB when the RF cancellation circuit is operating.

Reliability tests were performed in excess of 400 hours with the RF cancellation circuit operating in a temperature range from 0°C to 44°C (110°F). There was no degradation in the circuit performance during or after these reliability tests.

3.4 Production RF Cancellation Assembly

As was specified in the contract, SwRI investigated the possible requirements for a production quantity procurement of RF cancellation assemblies based upon this investigative program. Although no decision by the U.S. Coast Guard to procure such production units has yet been made, the units described in this section can act as a guide for any subsequent procurement. Although SwRI provides budgetary cost estimates for 200 each such cancellation circuits, it is intended as a planning figure only. The information applied in this section could be used by the Coast Guard to prepare a comprehensive procurement specification which would allow competitive bidding on any subsequent procurement.

The production RF cancellation assembly (see Figure 14) can be designed to be installed either in the Motorola transceiver rack or adjacent to the transceiver in a separate rack assembly. Included with the RF cancellation assembly should be an installation kit (see Table 10) and an operation, installation, and maintenance manual. It is recommended that finished interface cables not be supplied but that all materials necessary for the cables be supplied instead. This would allow the lengths of the interface cables to be determined as appropriate during each installation. The production RF cancellation assembly should be connected to the transceiver as was shown in Figure 10.

The electronics in the RF cancellation assembly should be of a modular design for ease of maintenance and operation. The primary units in the assembly (see Figure 15) would be RF Assembly A1, RF and Logic Assembly A2, and interconnecting cables. The RF Assembly (A1) should be manufactured in accordance with the specifications in Appendix A by SwRI or another vendor. The RF and Logic Assembly (A2) could be an SwRI-produced item containing the phase and amplitude matching circuitry and the control electronics for that circuit. A block diagram of the RF Assembly (A1) is shown in Figure 16, and a block diagram of the RF and Logic Assembly (A2) is shown in Figure 17. All equipment would be

TABLE 9
20 dB NOISE QUIETING TEST DATA

| <u>Channel</u> | <u>Transmitter Frequency (MHz)</u> | <u>Transmitter Operation</u> | <u>Incident Field Strength at 156.8 MHz for 20 dB Noise Quieting on Guard Receiver ($\mu\text{V}/\text{m}$)</u> |
|----------------|--------------------------------------------|----------------------------------|------------------------------------------------------------------------------------------------------------------------------------|
| | -- | Off | 5.50 (ref) |
| 2 | 156.65 | On | 9.23 |
| 3 | 157.10 | On | 7.76 |
| 4 | 157.15 | On | 9.77 |
| 5 | 157.075 | On | 12.3 |
| 6 | 157.175 | On | 15.49 |

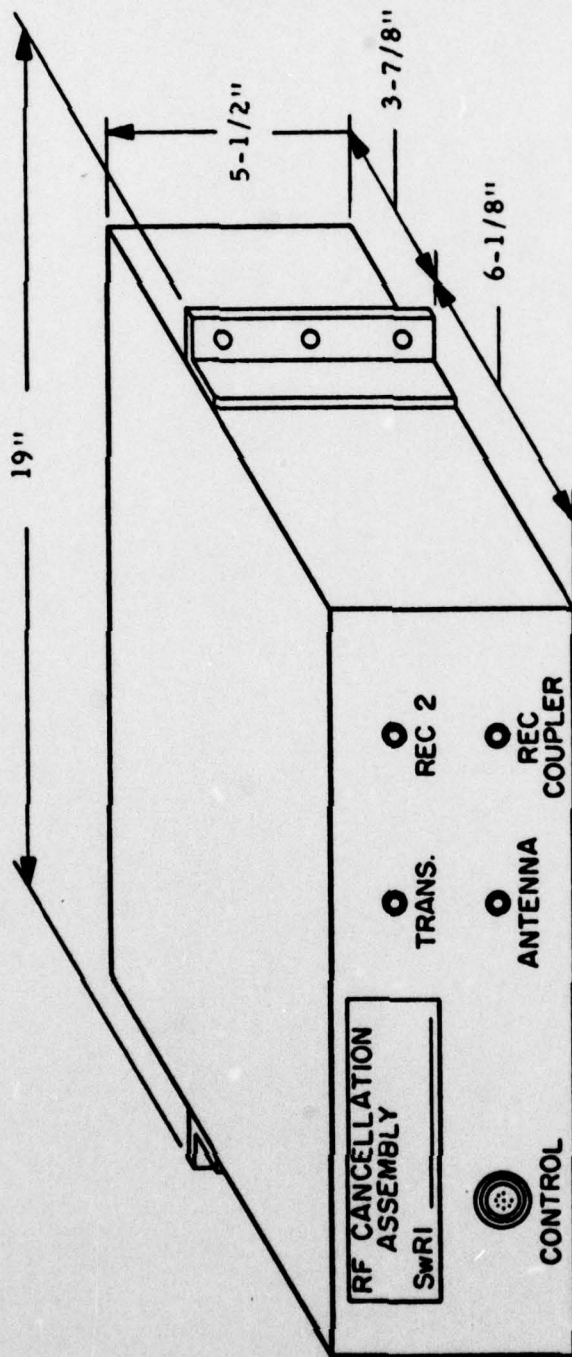

FIGURE 14. PROPOSED PRODUCTION RF CANCELLATION CIRCUIT

TABLE 10
MATERIAL IN INSTALLATION KIT

| <u>Item</u> | <u>Part Number</u> | <u>Quantity</u> |
|------------------------|-----------------------------------------------------|-----------------|
| 1. Receiver Back Panel | Motorla P/N 15-84254D01 | 2 |
| 2. Transmitter Shield | Motorola P/N TLN1434A | 1 |
| 3. Receiver Shield | Motorola P/N TLN 1435B | 1 |
| 4. Captive Screws | Motorola P/N B-84141D01 | A/R |
| 5. Sheet Metal Screws | Standard Hardware | A/R |
| 6. Cable Connectors | | |
| BNC | UG-88C | 3 |
| Phono Plug | Standard Hardware | 1 |
| Control Plug | Continental Connector P/N C9-20SVSN | A/R |
| 7. Cable | Commercially avail- able multiconductor cable | A/R |
| 8. Resistor | Large selection of carbon resistors | A/R |

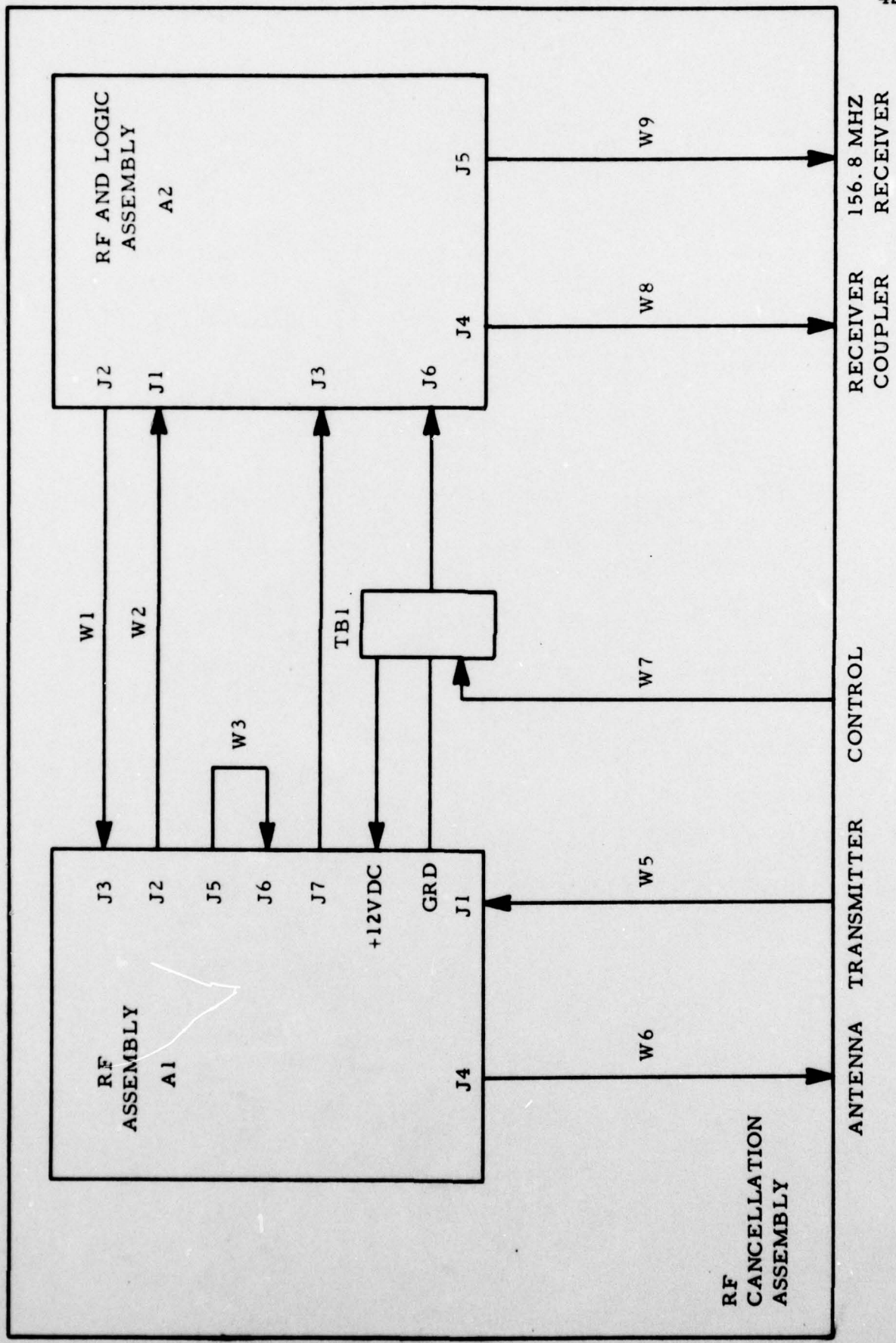

FIGURE 15. BLOCK DIAGRAM-- PRODUCTION RF CANCELLATION ASSEMBLY

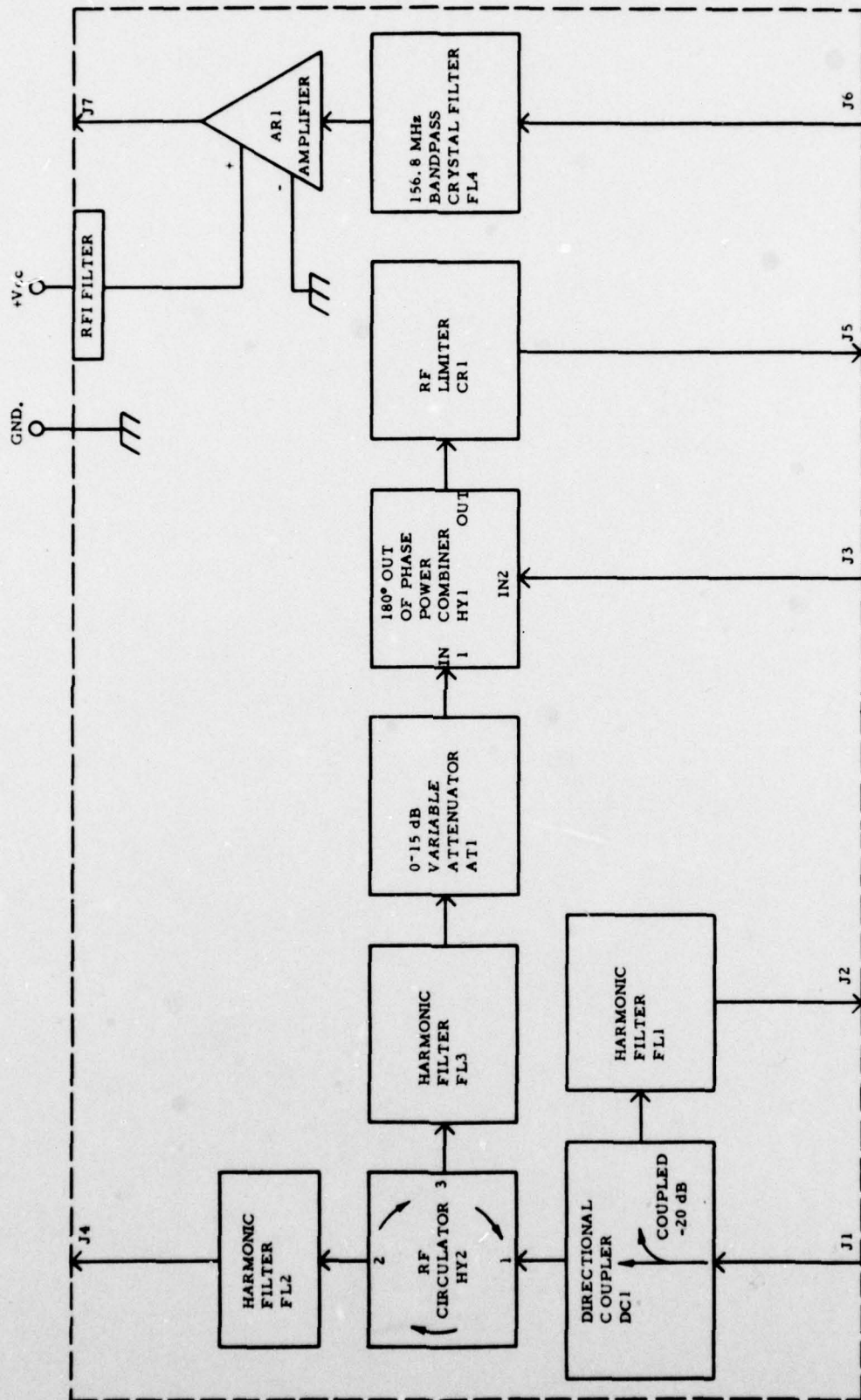

FIGURE 16. BLOCK DIAGRAM--RF ASSEMBLY A1

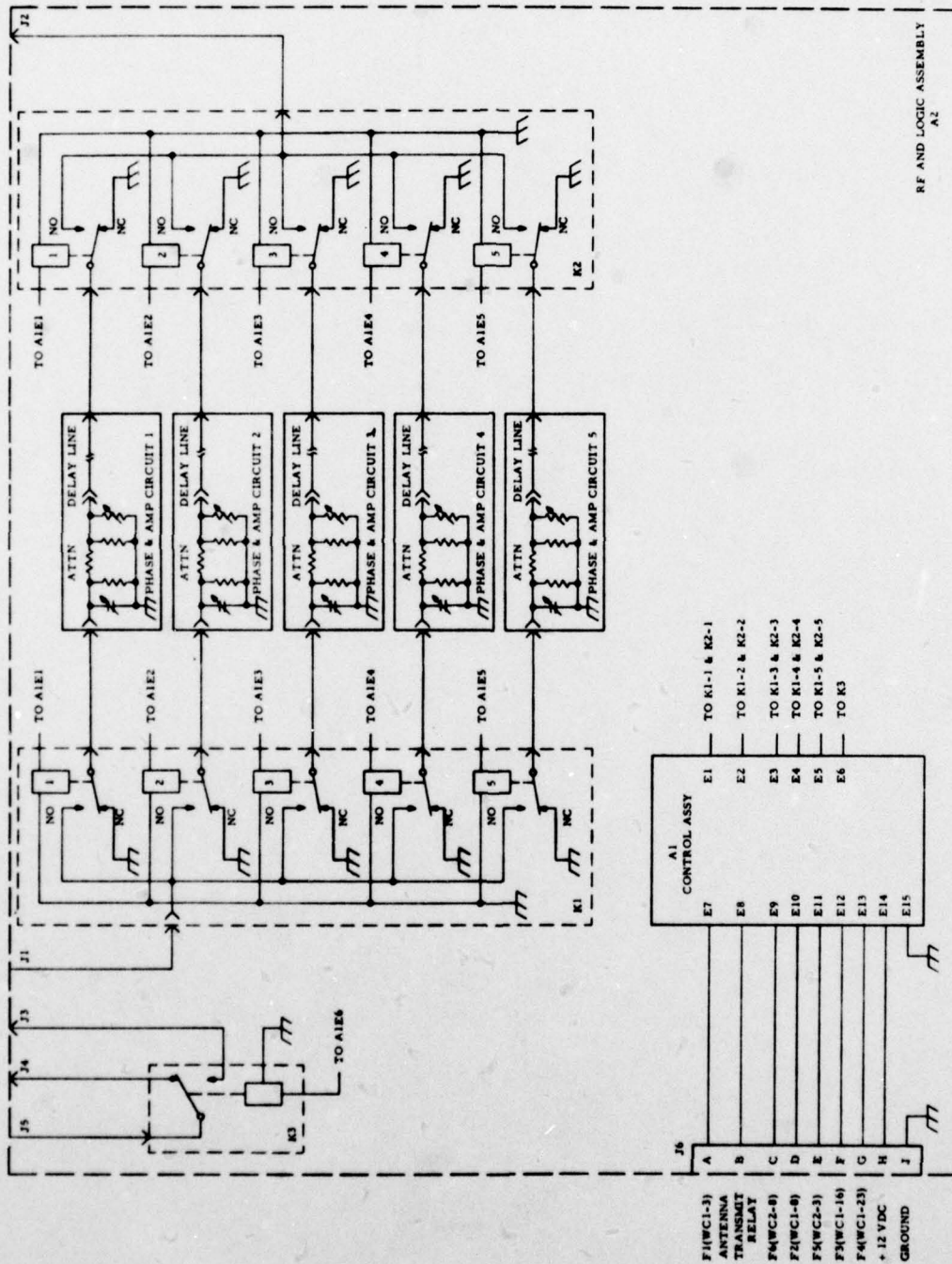

FIGURE 17. BLOCK DIAGRAM--RF AND LOGIC ASSEMBLY

designed to meet the environmental and electrical specifications stated in EIA Standard RS-204A, "Minimum Standards for Land Mobile Communications FM or PM Receivers, 25-470 MHz."

The production RF cancellation assembly could be installed in any transceiver with minimum interface and installation requirements. An outline of the interface and installation procedures is given below:

- (1) Install the production RF cancellation assembly in the transceiver or in an adjacent rack.
- (2) Measure the length of RF and control interface cables required for the installation and construct the cables in accordance with the procedures in the installation instructions.
- (3) With the transmit/receive antenna connected to the cancellation assembly, measure the amount of phase and amplitude offset required to produce maximum cancellation at the output of the out-of-phase power combiner. A special installation instrument is recommended for these measurements.* The instrument should be capable of providing a direct indication of the required phase and amplitude offset.
- (4) Construct delay lines from the RG-316/U cable and attenuators from the selection of carbon resistors provided with the installation material.
- (5) Install the delay lines and attenuators in the RF cancellation assembly and adjust the variable resistors and capacitors in the attenuators for maximum cancellation.
- (6) Complete the connection of interface cables and test the RF cancellation circuit for proper operation.

A budgetary cost estimate for 200 complete RF cancellation assemblies is shown below. This estimate does not include installation or spare parts.

| | |
|------------------------------------------------------------------------------|------------------------|
| Design, fabricate, and delivery 200 | |
| each RF cancellation assemblies, | \$580,000 |
| operation, installation, and maintenance manuals, and installation materials | (\$2,900 per assembly) |
| in 15-month period. | |

*A phase and amplitude variable device is being supplied under this contract which (by temporarily connecting the device to the RF cancellation unit) allows the correct values to be rapidly measured.

4.0 CONCLUSIONS AND RECOMMENDATIONS

The following conclusions and recommendations are the result of the SwRI design program for an RF cancellation circuit:

- (1) The SwRI designed RF cancellation circuit provides a minimum of 109 dB of attenuation of the undesired transmitter signal at the input to the guard receiver. With the receiver selectivity of 95 dB at a 30 kHz bandwidth, the undesired transmitter signal is effectively attenuated 204 dB. This provides a signal approximately 34 dB below the receiver's equivalent noise input.
- (2) The sensitivity of the guard receiver is degraded an average of 5.68 dB whenever the RF cancellation circuit is operating (transceiver in transmit mode).
- (3) The sensitivity of the guard receiver is not degraded when the RF cancellation circuit is not operating.
- (4) The transmitter's RF signal is attenuated less than 2 dB by the RF cancellation circuit.
- (5) The SwRI designed RF cancellation circuit was assembled using commercially available components that meet the requirements of EIA Standard RS-204.
- (6) Installation of the SwRI designed RF cancellation assembly requires no major modification to the Motorola transceiver (Model C53RTB-1146C-SP2). However, the addition of standard receiver and transmitter back panels and shields is required for proper operation of the assembly.

APPENDIX A

**SPECIFICATION FOR MODULAR
RF CANCELLATION ASSEMBLY**

SOUTHWEST RESEARCH INSTITUTE
6220 CULEBRA ROAD, SAN ANTONIO, TX 78284

ELECTROMAGNETICS DIVISION

DOCUMENT NO. 4928-MRCA-1

PROCUREMENT SPECIFICATION
FOR THE
MODULAR RF CANCELLATION ASSEMBLY

CHANGE LOG

The original document and all revised and change documents are identified in the following log.

Original Document Release Date:

| REVISIONS | | | | |
|-----------|-------------|-----------------|----------------|-----------------|
| Date | Prepared by | Approvals | | Revision Letter |
| | | Project Manager | Vice President | |
| | | | | |

TABLE OF CONTENTS

| | <u>Page</u> |
|-------------------------------------------------|-------------|
| 1.0 Introduction | 1 |
| 2.0 Applicable Documents | 1 |
| 3.0 Requirements | 1 |
| 3.1 Production Units | 1 |
| 3.2 Design and Construction | 1 |
| 3.3 Electrical Characteristics | 1 |
| 3.4 Environmental Conditions | 5 |
| 3.5 Configuration | 5 |
| 3.6 Storage Life | 5 |
| 3.7 Interchangeability | 5 |
| 4.0 Quality Assurance Provisions | 5 |
| 4.1 Responsibility for Inspection | 5 |
| 4.1.1 Supplier's Quality Assurance System | 7 |
| 4.1.2 Failure Reporting | 7 |
| 4.2 Quality Conformance Inspection | 7 |
| 4.2.1 Scope | 7 |
| 4.2.2 Acceptance Tests at Manufacturer | 7 |
| 4.2.3 Acceptance Tests at SwRI | 7 |
| 4.3 Documentation | 7 |
| 4.4 Certificate of Compliance | 8 |
| 4.5 Data Retention | 8 |
| 4.6 Guarantee | 8 |
| 5.0 Preparation for Delivery | 8 |
| 5.1 Packaging | 8 |
| 5.2 Packing | 8 |
| Appendix A--Manufacturer's Statement of Quality | 9 |

1.0 INTRODUCTION

The purpose of this document is to present the specifications for a modular RF cancellation assembly.

2.0 APPLICABLE DOCUMENTS

The following documents of the issue in effect on the date of the purchase order form a part of this document to the extent specified herein. In the event of any conflict, this document shall govern.

| | |
|-------------|-----------------------------------------------------------------------------------------------|
| RS-204 | EIA Standard, Minimum Standards for Land Mobile Communications FM or PM Receivers, 25-470 MHz |
| MIL-I-45208 | Inspection System Requirements |

3.0 REQUIREMENTS

3.1 Production Units

The production units shall consist of a contractually stated number of units. These units shall be capable of meeting the requirements stated herein.

3.2 Design and Construction

Design and construction of the units shall be in accordance with best commercial practices to meet the requirements stated herein.

3.3 Electrical Characteristics

The electrical characteristics of the modular RF cancellation assembly shown in Figure 1 shall be as follows:

| | |
|-------------------------------------------|--------------------------------------------------------------------------------------------------|
| Frequency Range | 155-159 MHz (min) |
| Impedance | 50 ohms at all RF ports |
| VSWR | 1.5:1 maximum |
| DC Power Requirement | +11 to +14 Vdc at 150 ma (max) |
| RF Power Handling Capability (Continuous) | 50 watts at J1, J2, and J4 1 watt at J3 10 milliwatts at J5 and J6 100 milliwatts at J7 |
| Gain (Input at J6, Output at J7) | 16 dB (± 3 dB) |

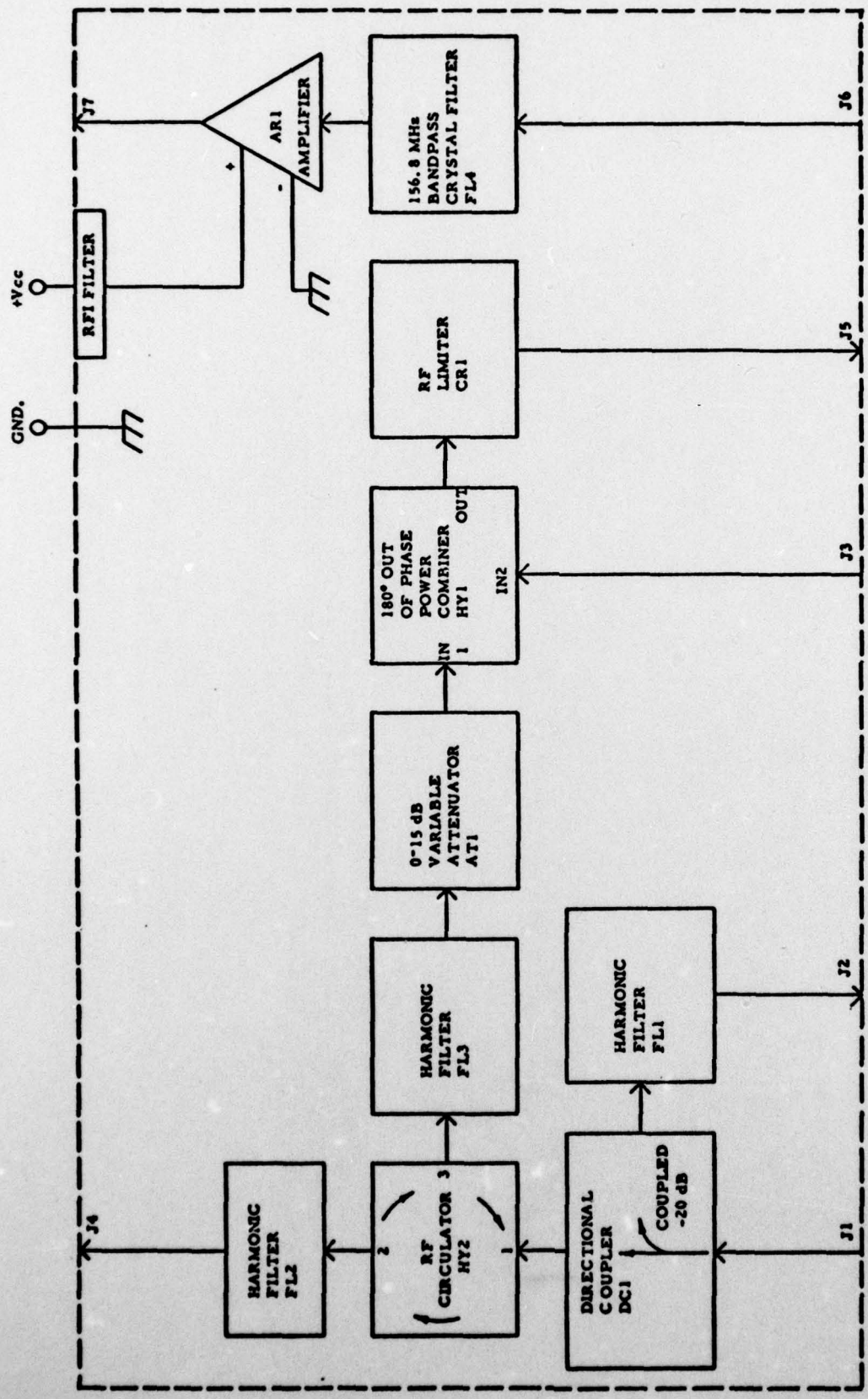

FIGURE 1. RF CANCELLATION ASSEMBLY BLOCK DIAGRAM

The electrical characteristics of the individual components shown in the figure shall be as follows:

AR1 Amplifier

| | |
|------------------------------------------------------|------------------------------------------------------|
| Frequency | 155-159 MHz |
| Gain | 22 dB \pm 1 dB |
| Noise Figure | 3.5 dB (max) |
| Impedance | 50 ohms |
| VSWR In/Out | 1.5:1 (max) |
| IM Performance | 3rd order: +35 dBm (min) 2nd order: +50 dBm (min) |
| Output Intercept 1 dB Output Compression Point | +20 dBm (min) |
| Input DC Power Requirements | +11 to +14 Vdc, 150 ma (max) |

AT1 Variable Attenuator

| | |
|-----------------|---------------------------------|
| Frequency Range | 155-159 MHz (min) |
| Attenuation | 0-15 dB (continuously variable) |
| Power | 10 watts (min) |
| Impedance | 50 ohms |
| VSWR | 1.5:1 (max) |

CR1 RF Limiter

| | |
|------------------------|------------------------------------|
| Frequency | 155-159 MHz (min) |
| Maximum Output Leakage | 10 milliwatts |
| Maximum Input | 10 watts continuous; 50 watts peak |
| Impedance | 50 ohms |
| VSWR | 1.2:1 (max) for low level signals |
| Insertion Loss | .5 dB (max) for low level signals |

DC1 Directional Coupler

| | |
|----------------|--------------------------------------------------|
| Frequency | 155-159 MHz (min) |
| Coupling | -20 dB \pm 1 dB |
| Directivity | 20 dB (min) |
| VSWR | 1.2:1 (max) |
| Impedance | 50 ohms |
| Insertion Loss | .2 dB (max) |
| Power | 50 watts continuous (min), incident on reflected |

FL1 through FL3 Harmonic Filters

| | |
|-----------------------|---------------------------|
| Frequency | 155-159 MHz (min) |
| 2nd and 3rd Harmonics | 60 dB down (min) |
| Power | 50 watts continuous (min) |
| Impedance | 50 ohms |
| VSWR | 1.2:1 (max) |
| Insertion Loss | .2 dB (max) |

FL4 Bandpass Crystal

| | |
|-----------------------------------------|---------------------------------|
| Center Frequency, f_0 | 156.8 MHz \pm .0005% at 25 °C |
| Insertion Loss | |
| Passband ($f_0 \pm 7$ kHz) | 6 dB (min) |
| Stopband ($f_0 \pm 60$ kHz or more) | 60 dB (min) |
| Passband Ripple | 1 dB (max) |
| Impedance | 50 ohms |
| VSWR | 1.5:1 (max) |
| Power Handling Capability | 10 milliwatts (min) |

HY1 180° Out-of-Phase Power Combiner

| | |
|-------------------|---------------------|
| Coupling | -3 dB |
| Isolation | 25 dB (min) |
| Amplitude Balance | 0.2 dB (min) |
| Phase Balance | 180° \pm 1° (min) |
| Insertion Loss | .75 dB (max) |
| Impedance | 50 ohms |
| VSWR | 1.3:1 (max) |
| Power | 10 watts (min) |
| Frequency | 155-159 MHz (min) |

HY2 RF Circulator

| | |
|------------------|---------------------------|
| Frequency | 155-159 MHz (min) |
| Isolation | |
| Center Frequency | 25 dB |
| Minimum | 20 dB |
| Insertion Loss | |
| Center Frequency | .5 dB |
| Maximum | .6 dB |
| VSWR | 1.2:1 (max) |
| Power | 50 watts continuous (min) |

3.4 Environmental Conditions

The modular RF cancellation assembly will meet or exceed the following environmental conditions for operation and storage:

| | |
|---------------|-------------------------------|
| Temperature | |
| Operating | -20 °C to +60 °C |
| Non-Operating | -62 °C to +75 °C |
| Humidity | 90% to 95% at 50 °C |
| Vibration | EIA Standard RS-204, Para. 22 |
| Shock | EIA Standard RS-204, Para. 23 |

3.5 Configuration

The modular RF cancellation assembly shall not exceed the configuration requirements in Figure 2. Maximum weight shall be 15 pounds.

3.6 Storage Life

The modular RF cancellation assembly shall be capable of meeting the electrical requirements provided in paragraph 3.3 after being subjected to storage at temperatures from -62 °C to +75 °C for five years.

3.7 Interchangeability

All modular RF cancellation assemblies having the same manufacturer's part number shall be directly and completely interchangeable with each other with respect to installation and performance.

4.0 QUALITY ASSURANCE PROVISIONS

4.1 Responsibility for Inspection

Unless otherwise specified in the purchase order, the supplier is responsible for the performance of all inspection requirements as specified herein.

Southwest Research Institute reserves the right to perform or witness any of the inspections set forth in this specification where such inspections are deemed necessary to assure that the supplier and his services conform to the prescribed requirements.

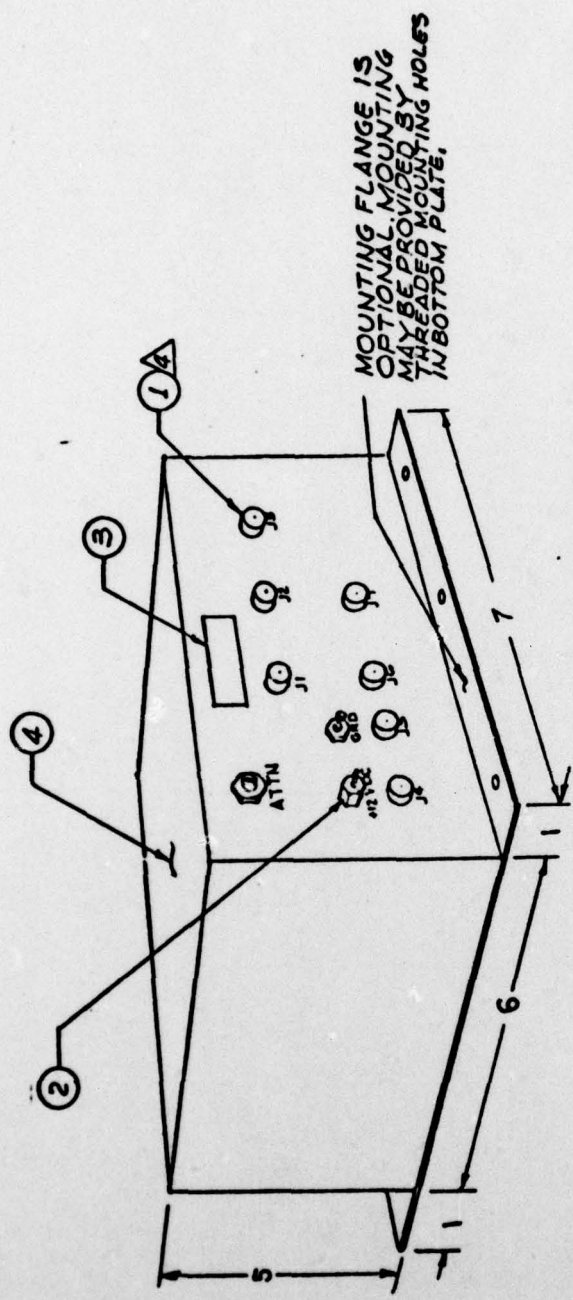

- NOTES:**
- 1. ENVELOPE DIMENSIONS ARE MAXIMUM ALLOWABLE
 - 2. MAXIMUM WEIGHT IS 15 POUNDS
 - 3. ALL DIMENSIONS ARE IN INCHES.
 - 4. ALL CONNECTORS MUST BE MOUNTED ON SAME SIDE AS SHOWN, CONNECTOR LOCATION ON THIS SIDE MAY BE DETERMINED BY MANUFACTURER.

| ITEM NO | QTY | DESCRIPTION |
|---------|-----|-----------------------|
| 4 | 1 | METAL ENCLOSURE |
| 3 | 1 | NAME PLATE |
| 2 | 1 | RFI FILTER FEED THRU |
| 1 | 7 | BNC FEMALE CONNECTORS |

FIGURE 2. RF CANCELLATION ASSEMBLY ENCLOSURE SPECIFICATIONS

4.1.1 Supplier's Quality Assurance System

The supplier shall provide and maintain an inspection system complying with MIL-I-45208. The supplier's quality control manual shall be submitted for approval within two weeks after receipt of order. Any changes to the approved quality assurance system which might affect the degree of assurance required by this specification or other applicable documents shall be submitted for approval prior to use.

4.1.2 Failure Reporting

The quality assurance program shall include provisions for failure reporting. Failure reporting is required during the acceptance tests.

4.2 Quality Conformance Inspection

4.2.1 Scope

The testing of the amplifiers consist of the following classifications:

- (1) Acceptance Tests at the manufacturer
- (2) Acceptance tests at SwRI

4.2.2 Acceptance Tests at Manufacturer

The supplier will perform acceptance testing on the deliverable units to confirm the performance requirements stated herein. The supplier will furnish acceptance test procedures to SwRI at least three weeks prior to testing. Acceptance tests at the supplier's facility will constitute SwRI acceptance for all units except the first article.

Acceptance tests will be performed on all units produced and will cover VSWR, gain, and dc power. Accept/reject limits are indicated by the parameter tolerances in paragraph 3.3.

4.2.3 Acceptance Tests at SwRI

Southwest Research Institute will conduct acceptance tests on the first article delivered. The test will be limited to a check of the VSWR, gain, and dc power at room ambient temperature.

4.3 Documentation

The documents specified in paragraphs 4.1.1, 4.2.2, and 4.4 shall be prepared and submitted to SwRI within the periods noted.

4.4 Certificate of Compliance

The supplier shall fill in and ship with the articles the completed SwRI Form No. 48 entitled "Manufacturer's Statement of Quality." A copy of Form No. 48 is provided in Appendix A.

4.5 Data Retention

All data shall be retained by the supplier for a period of three years after completion of the order.

4.6 Guarantee

The manufacturer will guarantee all parts and materials for the period of one year after delivery against all defects in materials and workmanship.

5.0 PREPARATION FOR DELIVERY

5.1 Packaging

The modular RF cancellation assembly shall be packaged to prevent any damage during shipment. The supplier shall be responsible for any damage to the modular RF cancellation assembly due to faulty packaging.

5.2 Packing

The modular RF cancellation assembly shall be packed in containers of the type, size, and kind commonly used which will ensure acceptance by common carriers and safe delivery at the following destination:

Southwest Research Institute
6220 Culebra Road
San Antonio, TX 78284
Attention: William Guion

APPENDIX A

MANUFACTURER'S STATEMENT OF QUALITY

MANUFACTURER'S STATEMENT OF QUALITY

SwRI Purchase Order (P.O.) No.: _____

Date of P.O.: _____

Manufacturer's Order No.: _____

Relative to the above SwRI Purchase Order, _____
 (Manufacturer's Name)

certifies the following:

- (1) SwRI P.O. Items Nos. _____ fully
comply with the specified requirements.
- (2) SwRI P.O. Items Nos. _____ were actually
produced or assembled by the _____
 (Manufacturer's Name)
- (3) SwRI P.O. Items Nos. _____ conform to the
 _____ current standards of per-
 (Manufacturer's Name)
formance and quality.
- (4) The following dates of manufacture, lot numbers, date codes,
etc. apply:

SwRI P.O.
Item No.

Traceability Data (i.e., Date of Manu-
facture, Lot Number, Date Code, etc.)

Form No.: 48

Date: 24 August 1970

Page No.: 1 of 2

- (5) _____ agrees to maintain and preserve
(Manufacturer's Name)
records of evidence of compliance for three years from the
date of final payment. These records will be made available
for review upon request of Southwest Research Institute or
its designated representatives.

Signed:* _____

Title: _____

Date: _____

***Signature must be by a duly authorized representative of the
manufacturer.**

Form No.: 48
Date: 24 August 1970
Page No.: 2 of 2