

AD-A049 740

SYRACUSE UNIV N Y
EXPERIMENTAL VALIDATION OF THE ANTENNA PATTERN DISTORTION
DEC 77 J PERINI, H MOSES

F/6 9/5
F30602-75-C-0121

UNCLASSIFIED

RADC-TR-77-374

NL

1 OF 1
AD
A049740

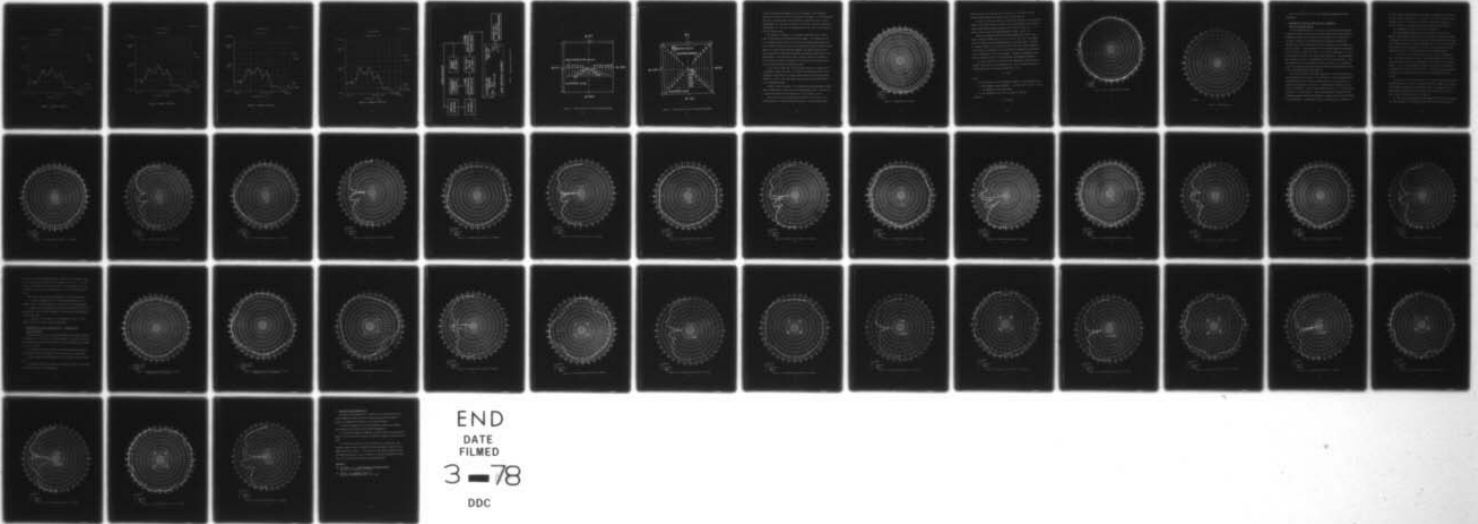

END
DATE
FILMED
3 - 78
DDC

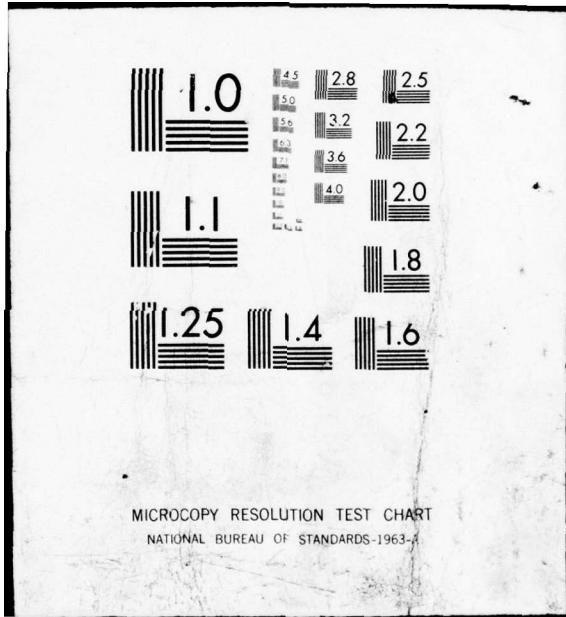

AD A 049740

RADC-TR-77-374
Phase Report
December 1977



2
SC

EXPERIMENTAL VALIDATION OF THE ANTENNA PATTERN DISTORTION
COMPUTER PROGRAM (VHF ANTENNA)

Dr. Jose' Perini
Mr. Hubert Moses

Syracuse University

12765.
JDC FILE COPY

Approved for public release; distribution unlimited.

ROME AIR DEVELOPMENT CENTER
Air Force Systems Command
Griffiss Air Force Base, New York 13441

DDC
RECEIVED
FEB 10 1978
B

This report contains a large percentage of machine-produced copy which is not of the highest printing quality but because of economical consideration, it was determined in the best interest of the government that they be used in this publication.

This report has been reviewed by the RADC Information Office (OI) and is releasable to the National Technical Information Service (NTIS). At NTIS it will be releasable to the general public, including foreign nations.

RADC-TR-77-374 has been reviewed and is approved for publication.

APPROVED:

Jacob Scherer
JACOB SCHERER
Project Engineer

APPROVED:

Joseph J. Naresky
JOSEPH J. NARESKY
Chief, Reliability & Compatibility Division

FOR THE COMMANDER:

John P. Huss
JOHN P. HUSS
Acting Chief, Plans Office

If your address has changed or if you wish to be removed from the RADC mailing list, or if the addressee is no longer employed by your organization, please notify RADC (RBC) Griffiss AFB NY 13441. This will assist us in maintaining a current mailing list.

Do not return this copy. Retain or destroy.

UNCLASSIFIED

SECURITY CLASSIFICATION OF THIS PAGE (When Data Entered)

REPORT DOCUMENTATION PAGE		READ INSTRUCTIONS BEFORE COMPLETING FORM
1. REPORT NUMBER RADC-TR-77-374 ✓	2. GOVT ACCESSION NO.	3. RECIPIENT'S CATALOG NUMBER
4. TITLE (and Subtitle) EXPERIMENTAL VALIDATION OF THE ANTENNA PATTERN DISTORTION COMPUTER PROGRAM (VHF ANTENNA)	5. TYPE OF REPORT & PERIOD COVERED Phase Report	
7. AUTHOR(s) Dr. Jose Perini Hubert Moses	6. PERFORMING ORG. REPORT NUMBER N/A	8. CONTRACT OR GRANT NUMBER(s) F30602-75-C-0121 ✓
9. PERFORMING ORGANIZATION NAME AND ADDRESS Syracuse University Syracuse NY 13210 ✓	10. PROGRAM ELEMENT, PROJECT, TASK AREA & WORK UNIT NUMBERS J. O. 95670016 1244 63203F	
11. CONTROLLING OFFICE NAME AND ADDRESS Rome Air Development Center (RBC) Griffiss AFB NY 13441	12. REPORT DATE December 1977	
14. MONITORING AGENCY NAME & ADDRESS (if different from Controlling Office) Same 12 58p.	13. NUMBER OF PAGES 50	
16. DISTRIBUTION STATEMENT (of this Report) Approved for public release; distribution unlimited.	15. SECURITY CLASS. (of this report) UNCLASSIFIED	
17. DISTRIBUTION STATEMENT (of the abstract entered in Block 20, if different from Report) Same	15a. DECLASSIFICATION/DOWNGRADING SCHEDULE N/A	
18. SUPPLEMENTARY NOTES RADC Project Engineer: Jacob Scherer (RBC)		
19. KEY WORDS (Continue on reverse side if necessary and identify by block number) Antennas Beam Pattern EM Waves Electromagnetic Compatibility		
20. ABSTRACT (Continue on reverse side if necessary and identify by block number) This report describes the procedures and the experimental measurements carried out to validate the Antenna Pattern Distortion Computer Program written for AFCS (RADC-TR-77-35, January 1977).		

D D C
RECEIVED
FEB 10 1978
RECEIVED
B

339 600

4B

PREFACE

This effort was conducted by Syracuse University under the sponsorship of the Rome Air Development Center Post-Doctoral Program for Rome Air Development Center. Mr. Richard Begelow EEG/DCIT was the task project engineer and provided overall technical direction and guidance.

The RADC Post-Doctoral Program is a cooperative venture between RADC and some sixty-five universities eligible to participate in the program. Syracuse University (Department of Electrical Engineering), Purdue University (School of Electrical Engineering), Georgia Institute of Technology (School of Electrical Engineering), and State University of New York at Buffalo (Department of Electrical Engineering) act as prime contractor schools with other schools participating via sub-contracts with the prime schools. The U.S. Air Force Academy (Department of Electrical Engineering), Air Force Institute of Technology (Department of Electrical Engineering), and the Naval Post Graduate School (Department of Electrical Engineering) also participate in the program.

The Post-Doctoral Program provides an opportunity for faculty at participating universities to spend up to one year full time on exploratory development and problem-solving efforts with the post-doctorals splitting their time between the customer location and their educational institutions. The program is totally customer-funded with current projects being undertaken for Rome Air Development Center (RADC), Space and Missile Systems Organization (SAMSO), Aeronautical System Division (ASD), Electronics Systems Divi-

DDC	DDC Section	<input checked="" type="checkbox"/>
UNANNOUNCED	UNANNOUNCED Section	<input type="checkbox"/>
JUSTIFICATION		<input type="checkbox"/>
BY _____		
DISTRIBUTION/AVAILABILITY CODES		
Dist.	AvAIL. and/or	SPECIAL
A		

sion (ESD), Air Force Avionics Laboratory (AFAL), Foreign Technology Division (FTD), Air Force Weapons Laboratory (AFWL), Armament Development and Test Center (ADTC), Air Force Communications Service (AFCS), Aerospace Defense Command (ADC), HQ USAF, Defense Communications Agency (DCA), Navy, Army, Aerospace Medical Division (AMD), and Federal Aviation Administration (FAA).

Further information about the RADC Post-Doctoral Program can be obtained from Mr. Jacob Scherer, RADC/RBC, Griffiss AFB, NY, 13441, telephone Autovon 587-2543, Commercial (315) 330-2543.

TABLE OF CONTENTS

Experimental Validation of the Antenna Pattern
Distortion Computer Program (VHF Antenna)

	Page
1. Introduction	1
2. Scale Model	1
3. Equipment and Model Check-out Runs	2
4. Measurements of the Two Antenna Set Up -- Comparison with the Calculated Results	17
5. Measurements of the Four Antenna Set Up -- Comparison with the Calculated Results	33
6. Conclusions and Recommendations	50

LIST OF FIGURES

Figure	Page
1. Actual Dimensions of AN 1181 (centimeters)	3
2. Scale Model of an AN 1181 , Dimensions in millimeters (inches) .	4
3. Antenna 7 VSWR Plot	5
4. Antenna 8 VSWR Plot	6
5. Antenna 9 VSWR Plot	7
6. Antenna 10 VSWR Plot	8
7. Measurement Equipment Set Up	9
8. Ground Plane for the Two Antenna Measurement	10
9. Ground Plane for the Four Antenna Measurement	11
10. Illuminating Probe Adjustment	13
11. Effect of Mounting Antenna Off-Center	15
12. System Calibration	16
13. Two Antenna Horizontal Pattern $\sim 0.5\lambda$ Spacing	19
14. Two Antenna Vertical Pattern $\sim 0.5\lambda$ Spacing.	20
15. Two Antenna Horizontal Pattern $\sim 0.75\lambda$ Spacing	21
16. Two Antenna Vertical Pattern $\sim 0.75\lambda$ Spacing	22
17. Two Antenna Horizontal Pattern $\sim 1.0\lambda$ Spacing.	23
18. Two Antenna Vertical Pattern $\sim 1.0\lambda$ Spacing	24
19. Two Antenna Horizontal Pattern $\sim 1.25\lambda$ Spacing	25
20. Two Antenna Vertical Pattern $\sim 1.25\lambda$ Spacing	26
21. Two Antenna Horizontal Pattern $\sim 1.5\lambda$ Spacing	27
22. Two Antenna Vertical Pattern $\sim 1.5\lambda$ Spacing	28
23. Two Antenna Horizontal Pattern $\sim 1.75\lambda$ Spacing	29
24. Two Antenna Vertical Pattern $\sim 1.75\lambda$ Spacing	30
25. Two Antenna Horizontal Pattern $\sim 2.0\lambda$ Spacing	31
26. Two Antenna Vertical Pattern $\sim 2.0\lambda$ Spacing	32

Figure

27. Measurement at Two Different Dates -- Two Antenna Horizontal Pattern $\sim 0.5\lambda$ Spacing	34
28. Measurement at Two Different Dates -- Two Antenna Horizontal Pattern $\sim 0.75\lambda$ Spacing	35
29. Four Antenna Horizontal Pattern $\sim 0.5\lambda$ Spacing	36
30. Four Antenna Vertical Pattern $\sim 0.5\lambda$ Spacing	37
31. Four Antenna Horizontal Pattern $\sim 0.75\lambda$ Spacing	38
32. Four Antenna Vertical Pattern $\sim 0.75\lambda$ Spacing	39
33. Four Antenna Horizontal Pattern $\sim 1.0\lambda$ Spacing.	40
34. Four Antenna Vertical Pattern $\sim 1.0\lambda$ Spacing	41
35. Four Antenna Horizontal Pattern $\sim 1.25\lambda$ Spacing	42
36. Four Antenna Vertical Pattern $\sim 1.25\lambda$ Spacing	43
37. Four Antenna Horizontal Pattern $\sim 1.5\lambda$ Spacing.	44
38. Four Antenna Vertical Pattern $\sim 1.5\lambda$ Spacing	45
39. Four Antenna Horizontal Pattern $\sim 1.75\lambda$ Spacing	46
40. Four Antenna Vertical Pattern $\sim 1.75\lambda$ Spacing	47
41. Four Antenna Horizontal Pattern $\sim 2.0\lambda$ Spacing	48
42. Four Antenna Vertical Pattern $\sim 2.0\lambda$ Spacing	49

EXPERIMENTAL VALIDATION OF THE ANTENNA
PATTERN DISTORTION COMPUTER PROGRAM
(VHF Antenna)

1. Introduction

The Antenna Pattern Distortion Computer Program was written at the request of AFCS to evaluate the distortion on the radiation pattern of communication antennas when mounted in close proximity to each other, such as in the communication towers of many AF installations.

Although the numerical method used in this computer program (Method of Moments [1]) has been shown to be very accurate in many applications, it was felt desirable to verify it with an experimental validation study. This was done at the RADC anechoic chamber. The first phase of the validation was for the VHF antenna AN1181. In view of the fact that the actual frequency range of this antenna (100-156 MHz) is below that of the RADC anechoic chamber, it was necessary to build a scale model of the antenna.

This report presents a description of the measurement procedure, the results and a comparison with the corresponding Antenna Pattern Distortion Computer Program runs.

2. Scale Model

It was decided that a scale model of approximately 10:1 scale ratio would be suitable, since this would result in a frequency of operation around 1GHz which is well within the capability of the RADC anechoic

chamber.

An AN-1181 was disassembled so that its actual dimensions could be obtained. This is shown in Figure 1.

The scale model shown in Figure 2 was then constructed. Note that the scale model is not tapered. This should not introduce any appreciable error in the measurements since the antenna radiation pattern is practically independent of its conductor's diameter over a very wide range of values. Note that the scale model dimensions in millimeters are very close to those of the full scale antenna in centimeters, indicating a 10:1 scale factor. The slight differences were due to the fact that they were rounded off to the closest inch and fraction to facilitate construction.

Four "identical" antennas were constructed. To determine how identical they were, a VSWR versus frequency measurement was carried out in the RADC HP network analyzer. The results are shown in Figures 3, 4, 5, and 6 for antennas #7, 8, 9 and 10, respectively. The plots are surprisingly similar showing that good mechanical tolerances were observed in their manufacture. Since the VSWR is about 3 at 1120 MHz, this was the chosen frequency for the measurements.

3. Equipment and Model Check-out Runs.

The measurement set-up used in this experiment is shown in Figure 7. The frequency and power were constantly monitored in the Frequency Counter and Power Meter.

It was decided that the scale model antennas were to be mounted in a two feet square ground plane at the positions shown in Figures 8 and 9 for two and four antenna clusters, respectively. The minimum separation of

AN 1181
(cm)

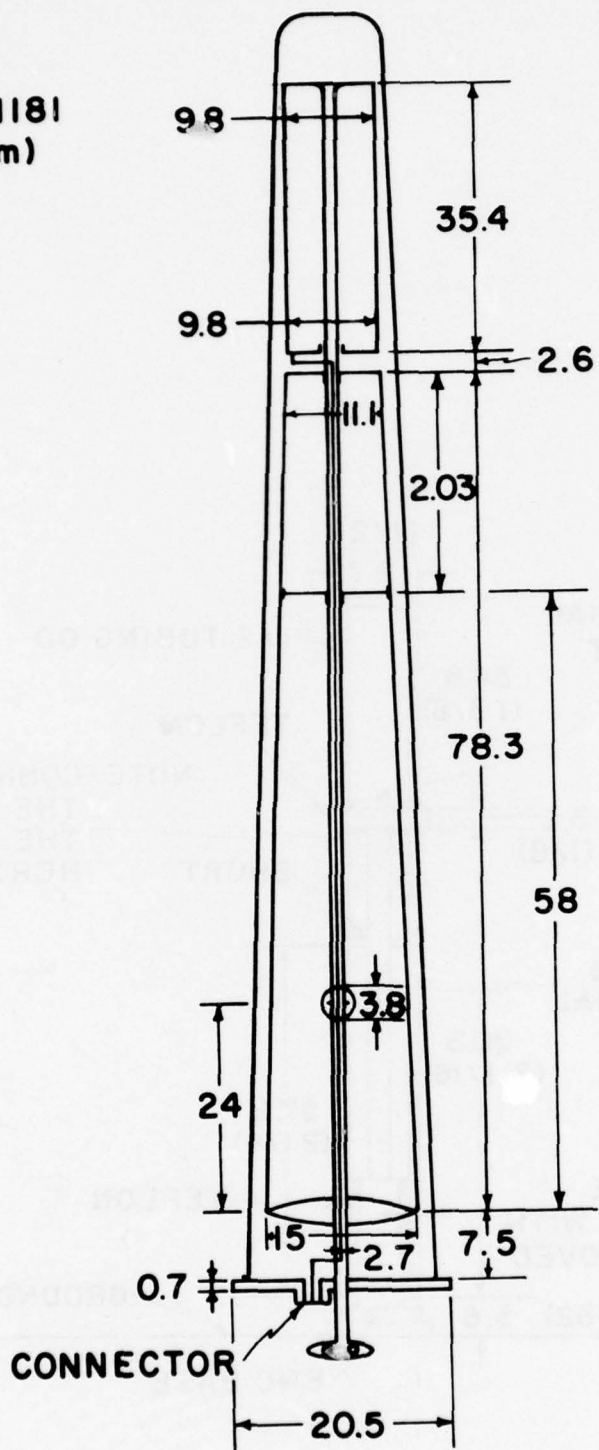

Figure 1. Actual Dimensions of AN 1181 (centimeters).

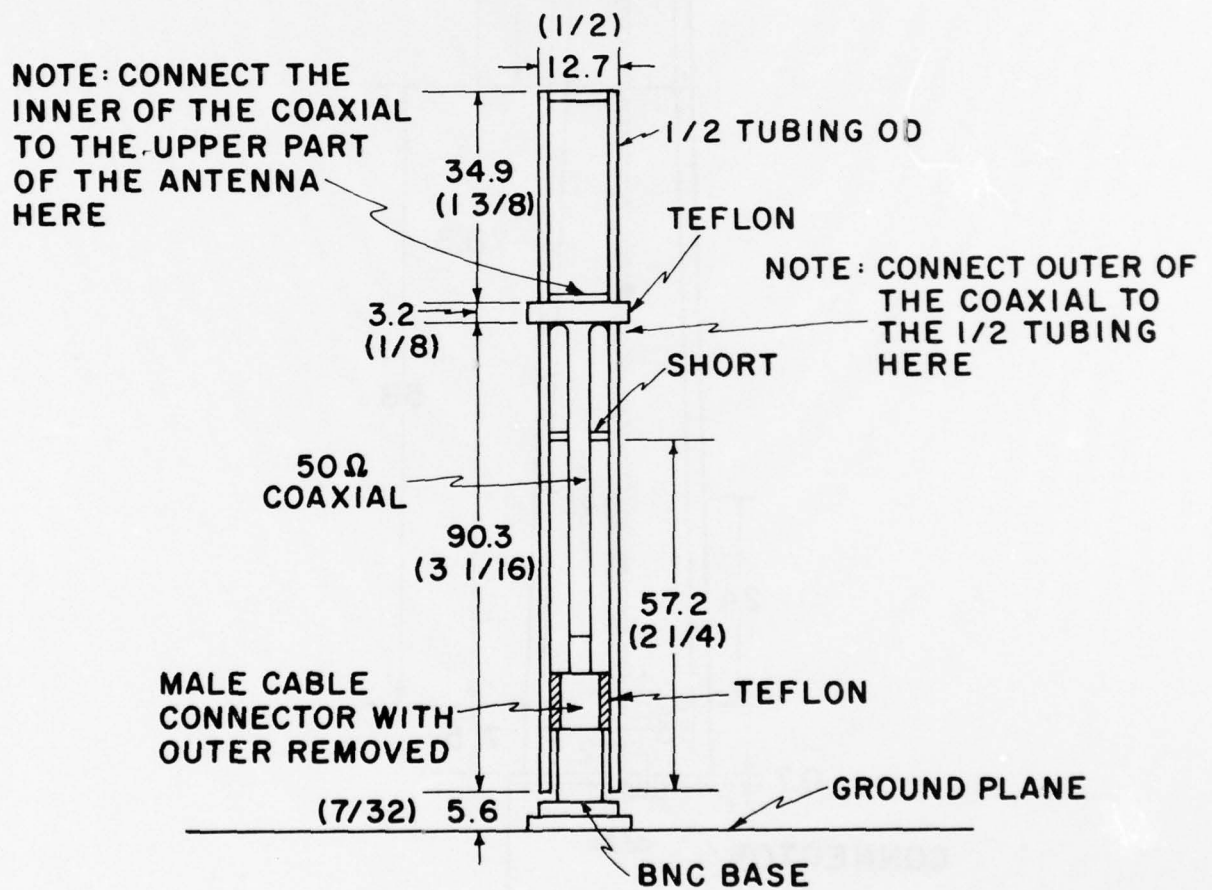

Figure 2. Scale Model of the AN 1181
Dimensions in millimeters (inches)

1

20 JULY 77

NEW ANTENNA

ANTENNA NO. 7

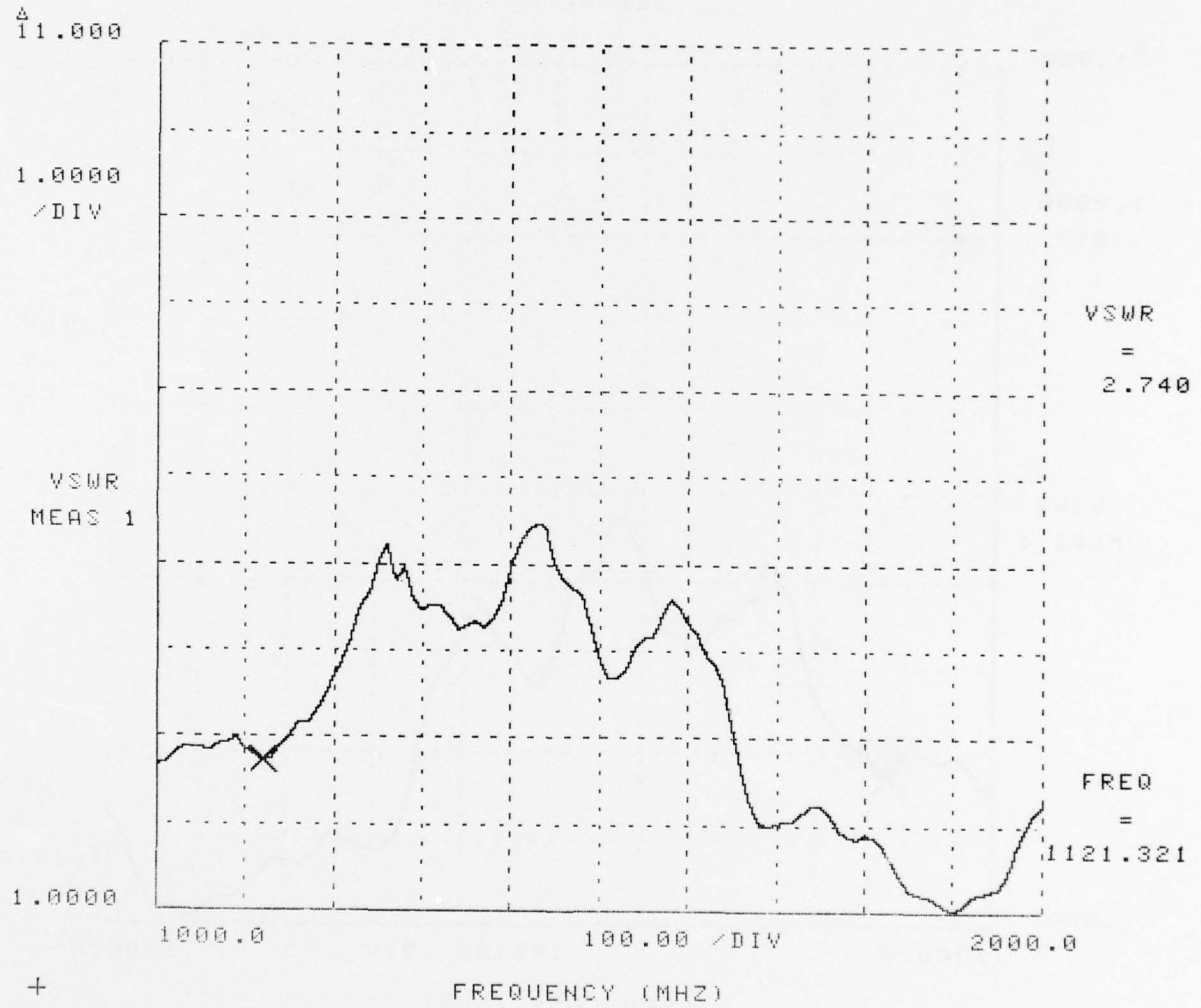

Figure 3. Antenna 7 VSWR Plot.

1

20 JULY 77

NEW ANTENNA

SERIAL NO. 8

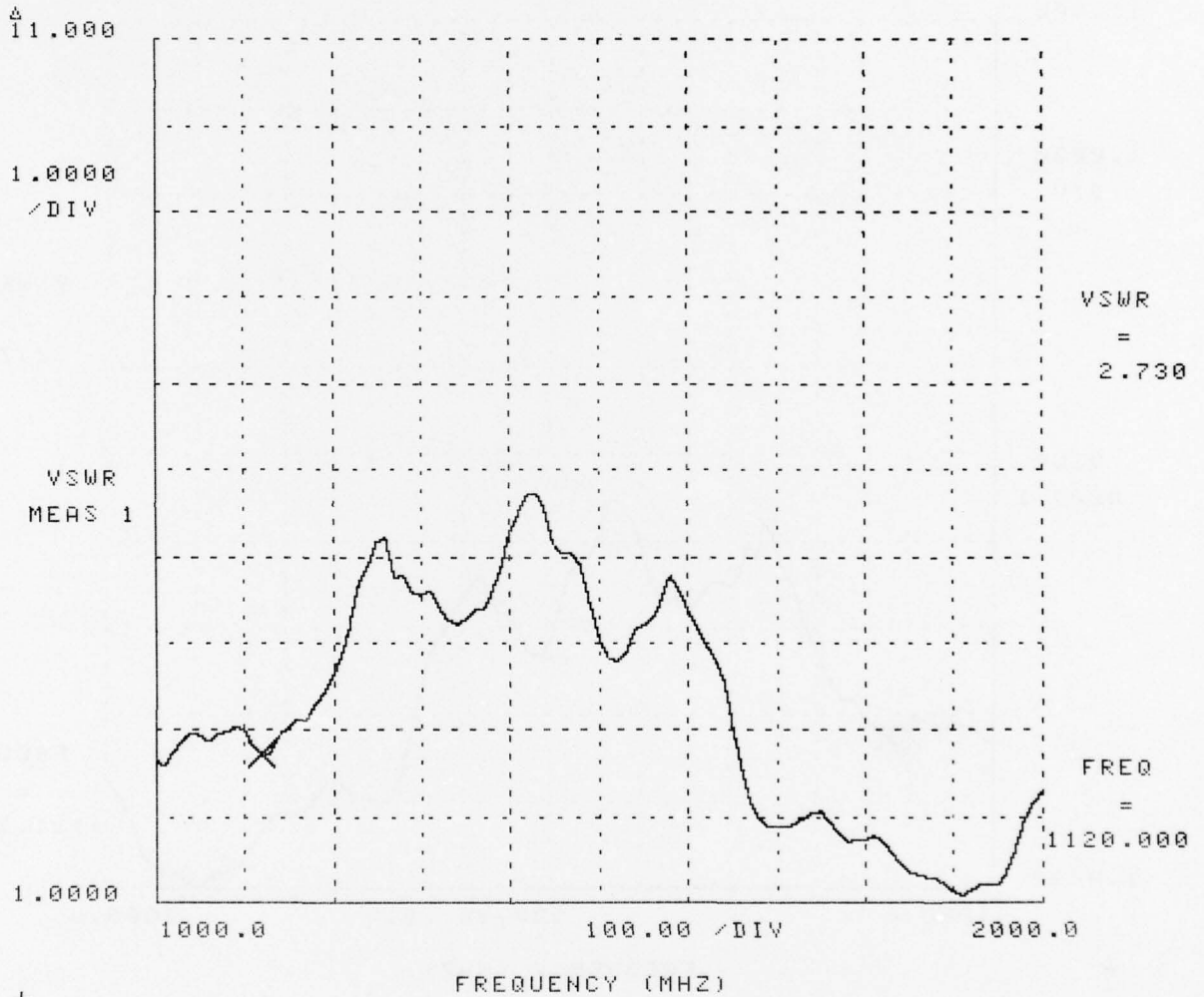

Figure 4. Antenna 8 VSWR Plot.

NEW ANTENNA

ANTENNA NO. 9

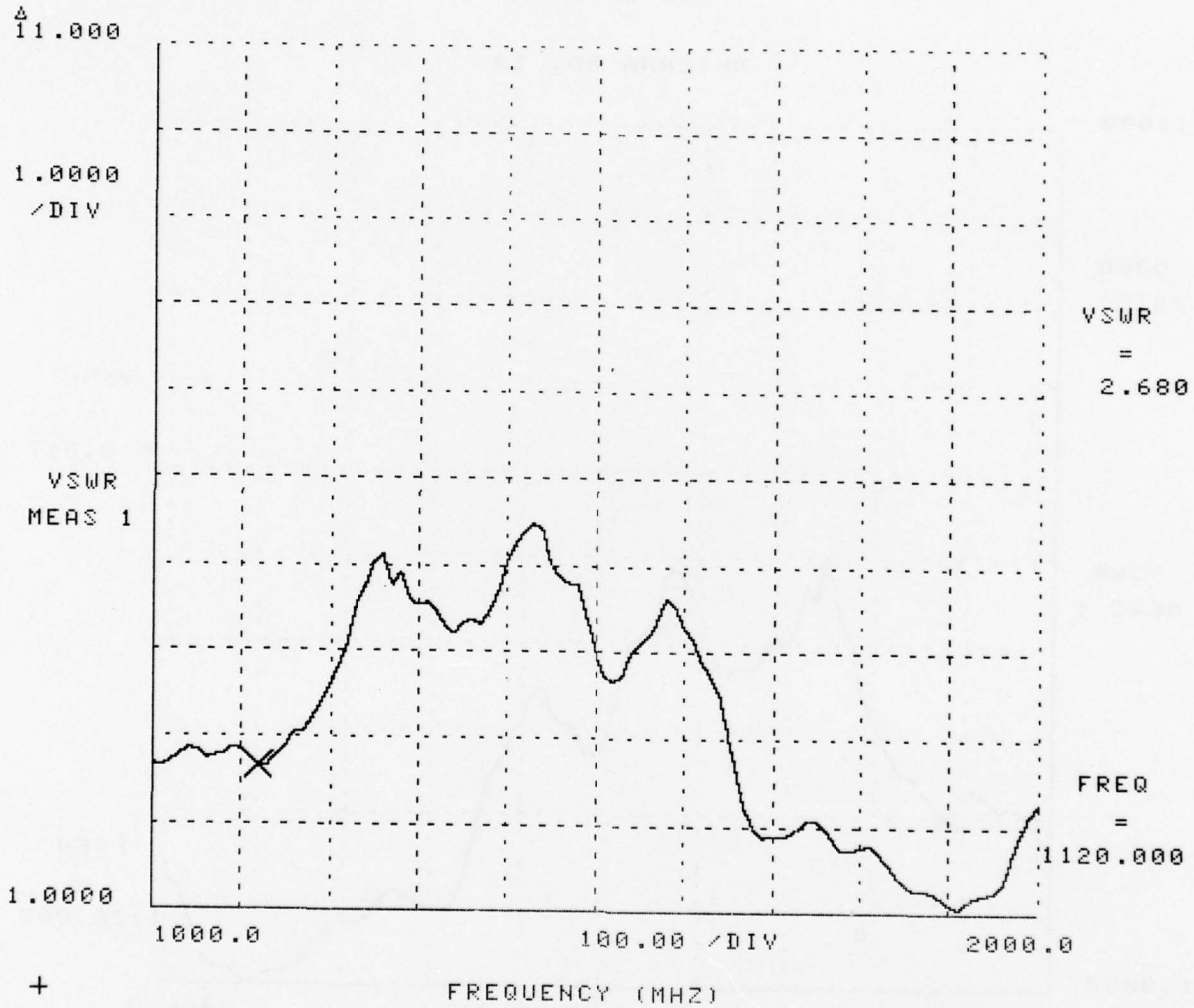

Figure 5. Antenna 9 VSWR Plot.

1

20 JULY 77

NEW ANTENNA

ANTENNA NO. 10

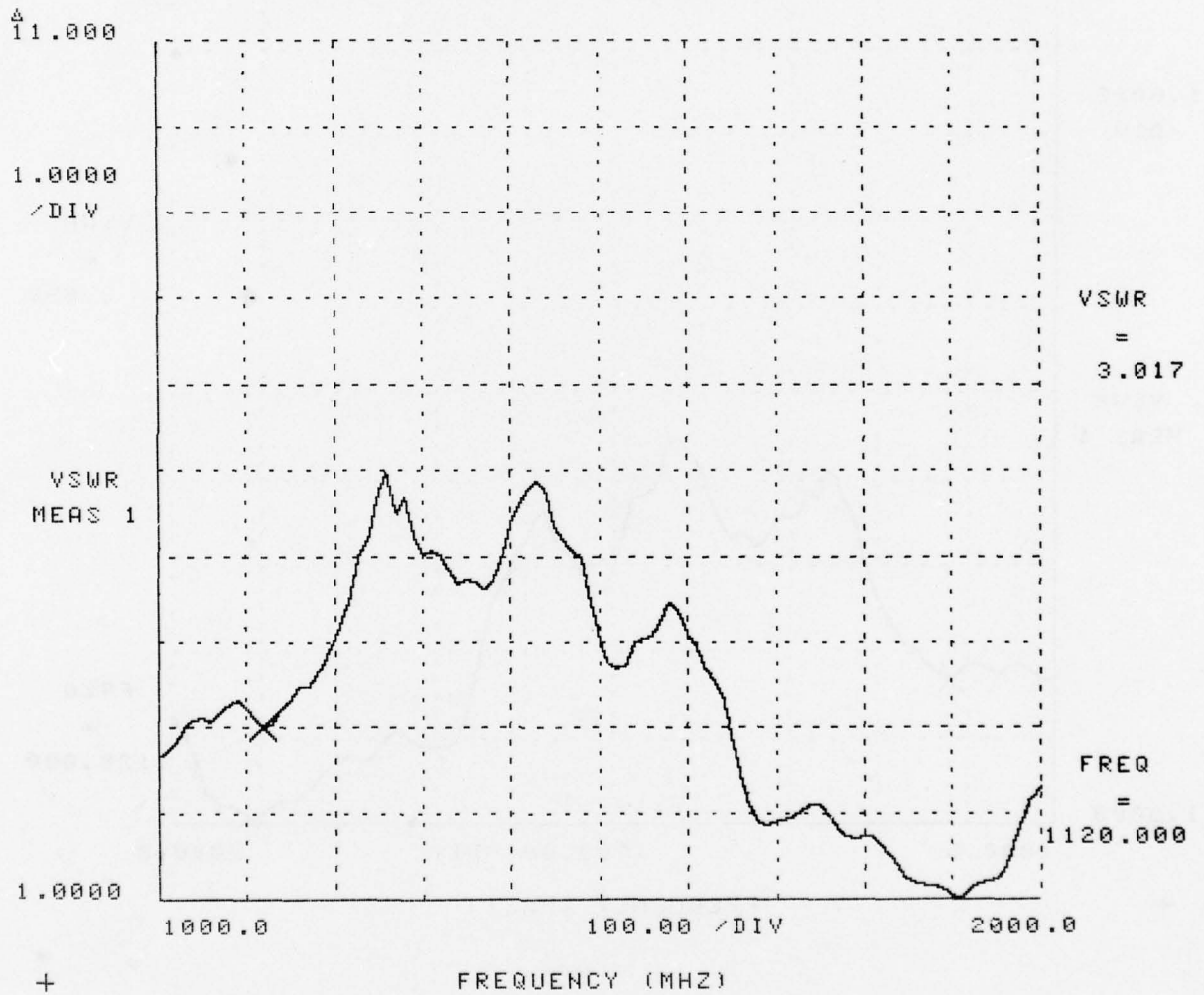

Figure 6. Antenna 10 VSWR Plot.

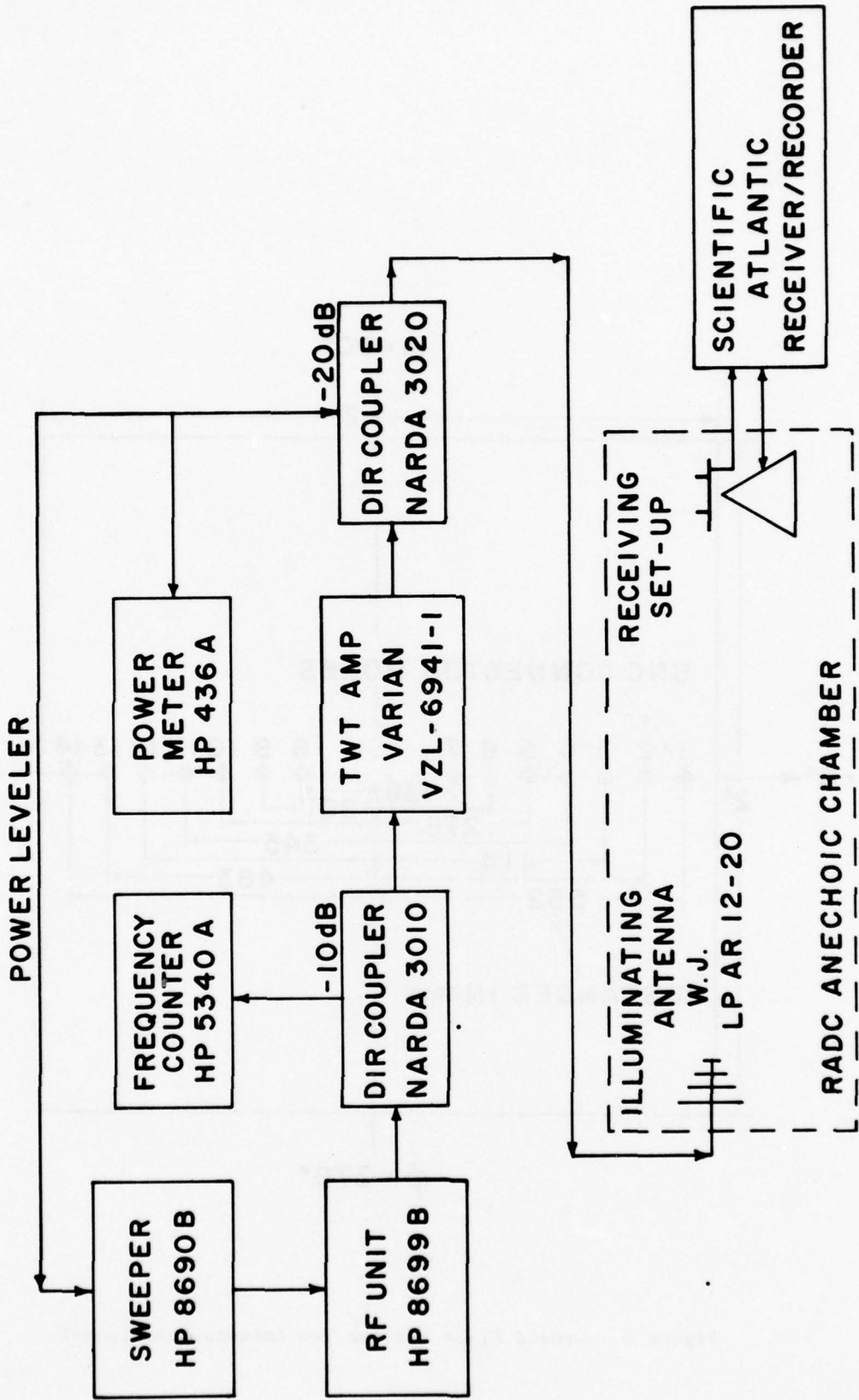

Figure 7. Measurement Equipment Set Up.

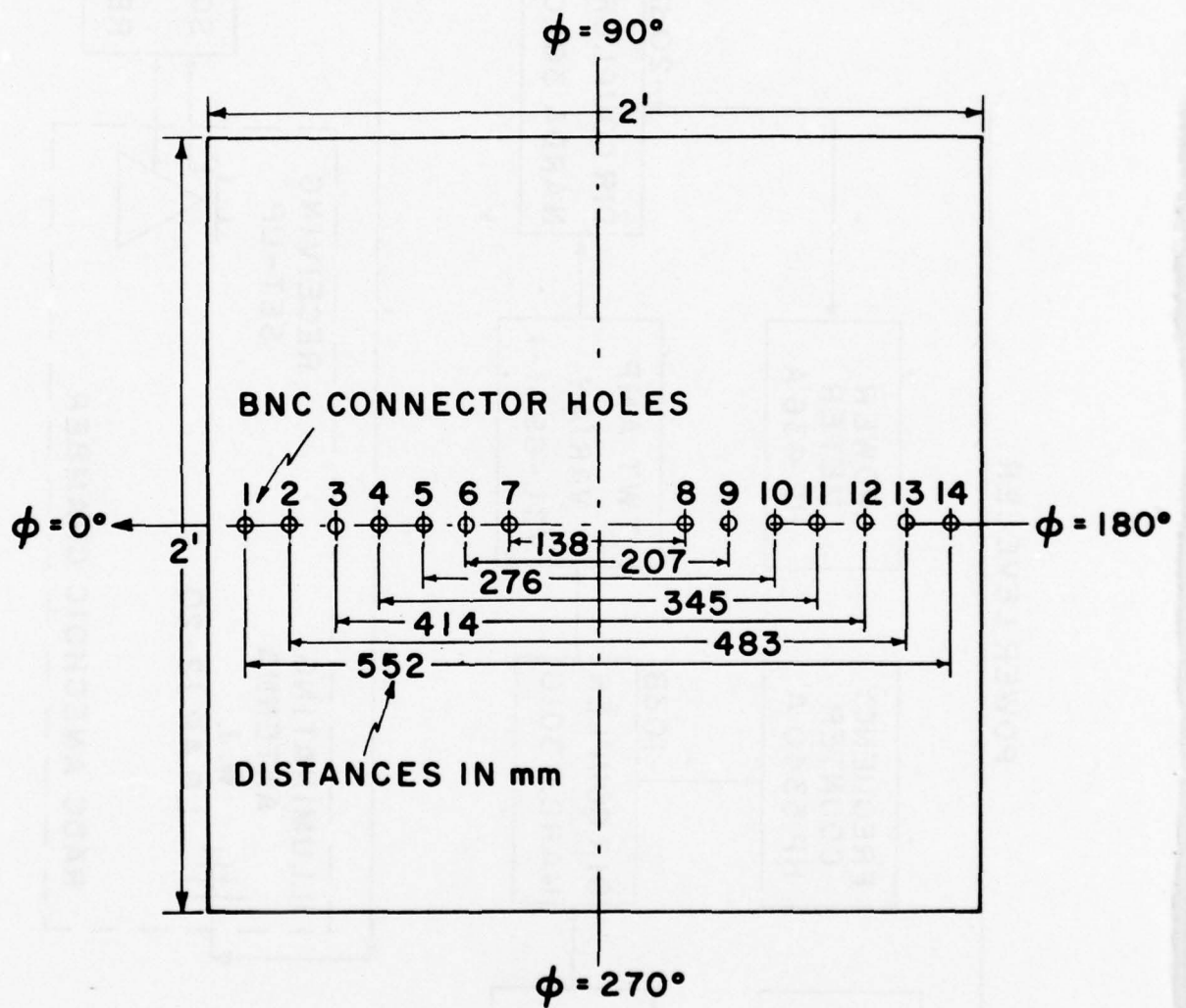

Figure 8. Ground Plane for the Two Antenna Measurement.

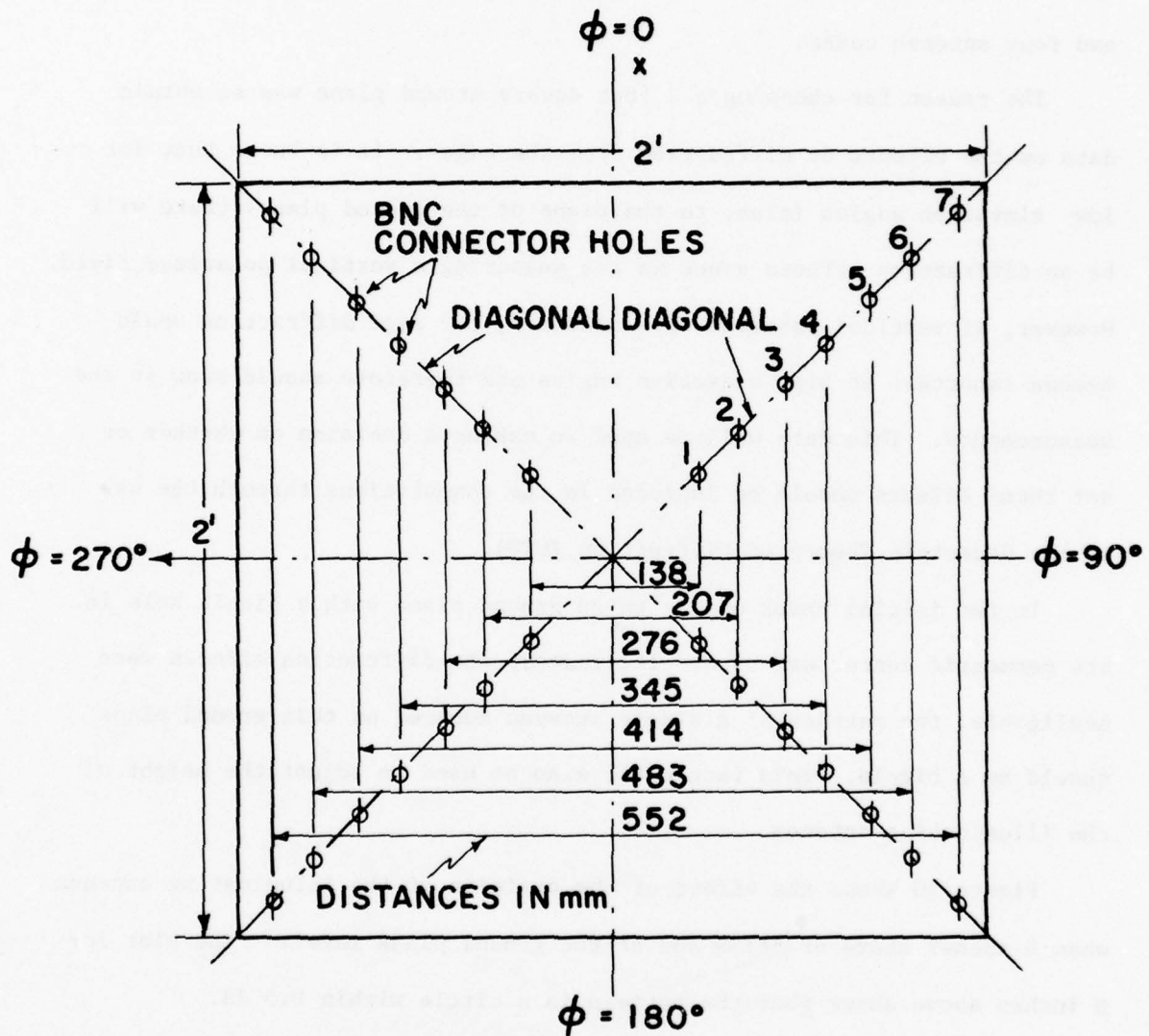

Figure 9. Ground Plane for the Four Antenna Measurement.

138 mm corresponds approximately to 0.52λ wavelengths. The subsequent separations increase in steps of 69 mm which corresponds to 0.26λ wavelengths. Therefore, the measurements were performed at separations that started at approximately 0.5λ and were increased by 0.25λ steps, reaching a maximum of approximately 2λ . Note that the separations are the same for both the two and four antenna cases.

The reason for choosing a 2 feet square ground plane was to obtain data on the effects of diffraction from the edges. It is known that for low elevation angles (close to the plane of the ground plane) there will be no diffraction effects since we are measuring a vertical polarized field. However, if vertical patterns were measured, the edge diffraction would become important at high elevation angles and therefore should show in the measurements. This data will be used in making a decision on whether or not these effects should be included in the computations through the use of the Geometric Theory of Diffraction (GTD).

In the initial check out, a third ground plane with a single hole in its geometric center was used. If, indeed, the diffraction effects were negligible, the pattern of a single antenna mounted on this ground plane should be a circle. This fact could also be used to adjust the height of the illuminating antenna.

Figure 10 shows the effect of the position of the illuminating antenna when 6 inches above or below and at the ground plane level. The plot for 6 inches above shows that the pattern is a circle within 0.5 dB.

Next, each of the four antennas were mounted in the center of the ground plane and a horizontal pattern recorded. They are surprisingly

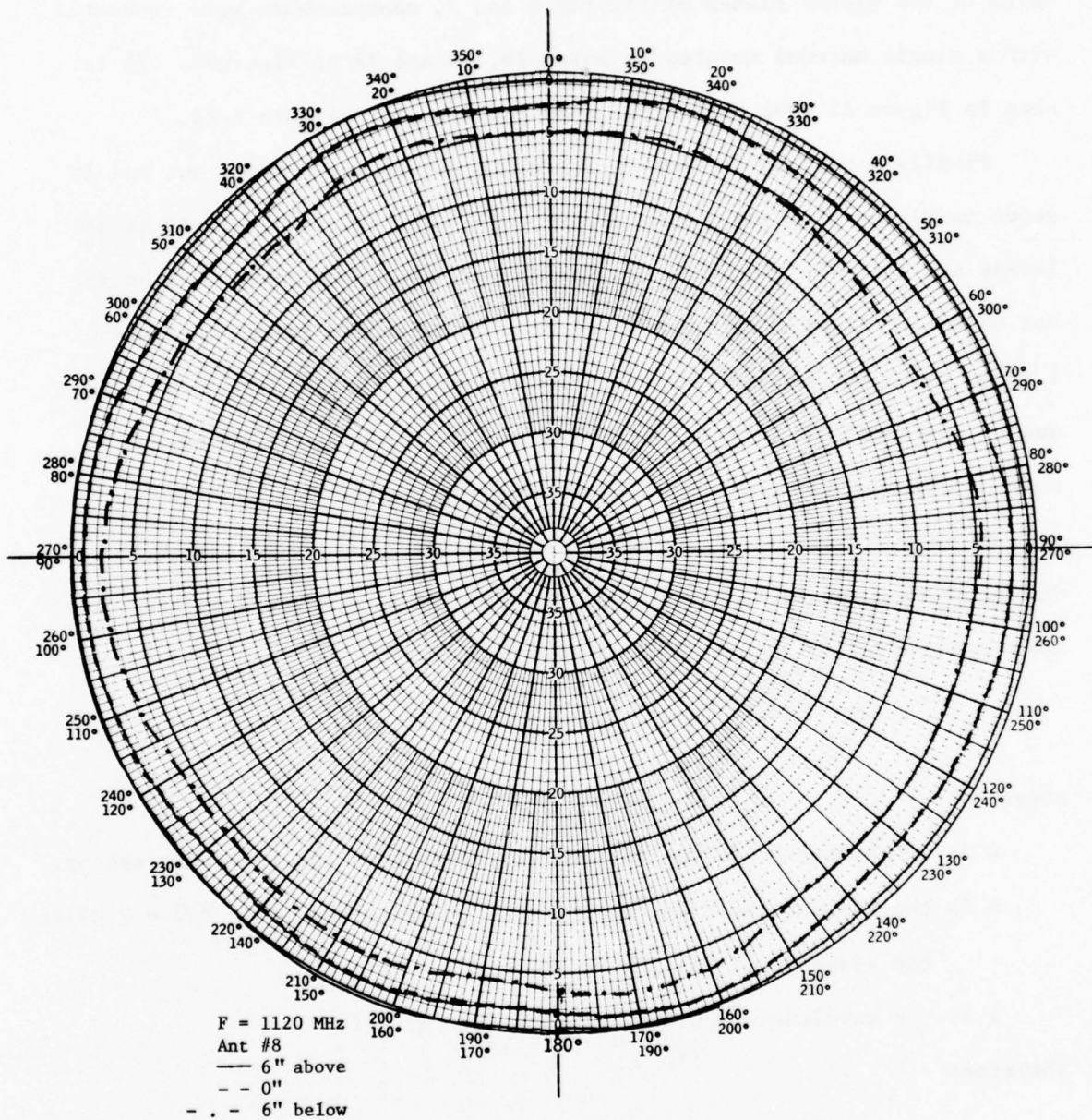

Figure 10. Illuminating Probe Adjustment.

identical and are the same as that of Figure 10 for the probe 6 inches above the ground plane and therefore are not presented here.

In order to verify the effect of mounting the antennas in the different holes of the ground planes of Figures 8 and 9, measurements were conducted with a single antenna mounted in holes #9, 10 and 12 of Figure 8. It is seen in Figure 11 that the patterns are now circular within 1 dB.

Finally a calibration run of the whole system was carried out and is shown in Figure 12 where the 0, -2, -5, -10, -15, -20, -30, -35 dB signal levels are shown by the corresponding dots on the graph paper. Although not shown in Figure 12, it was later verified that any signal strength of 1 dB or above is compressed on a circle about 1.0 dB above the 0 dB circle due to a mechanical stop on the recorder. Therefore, measurements that show an overshoot above the 0 dB line should be interpreted cautiously.

It is also necessary to assure that the illuminating antenna is producing a plane wave at the receiving set up. This is assured by the absorbing material of the anechoic chamber and if [2]

$$D > 2 \frac{A^2}{\lambda}$$

where

D is the distance of the illuminating antenna to the receiving set up.

A is the maximum receiving aperture. In this case it is $2\sqrt{2} = 2.83$ ft.

the diagonal of the ground plane.

λ is the wavelength = 0.27 m or 1.14 feet at 1120 MHz

Therefore

$$D > 14.07 \text{ feet}$$

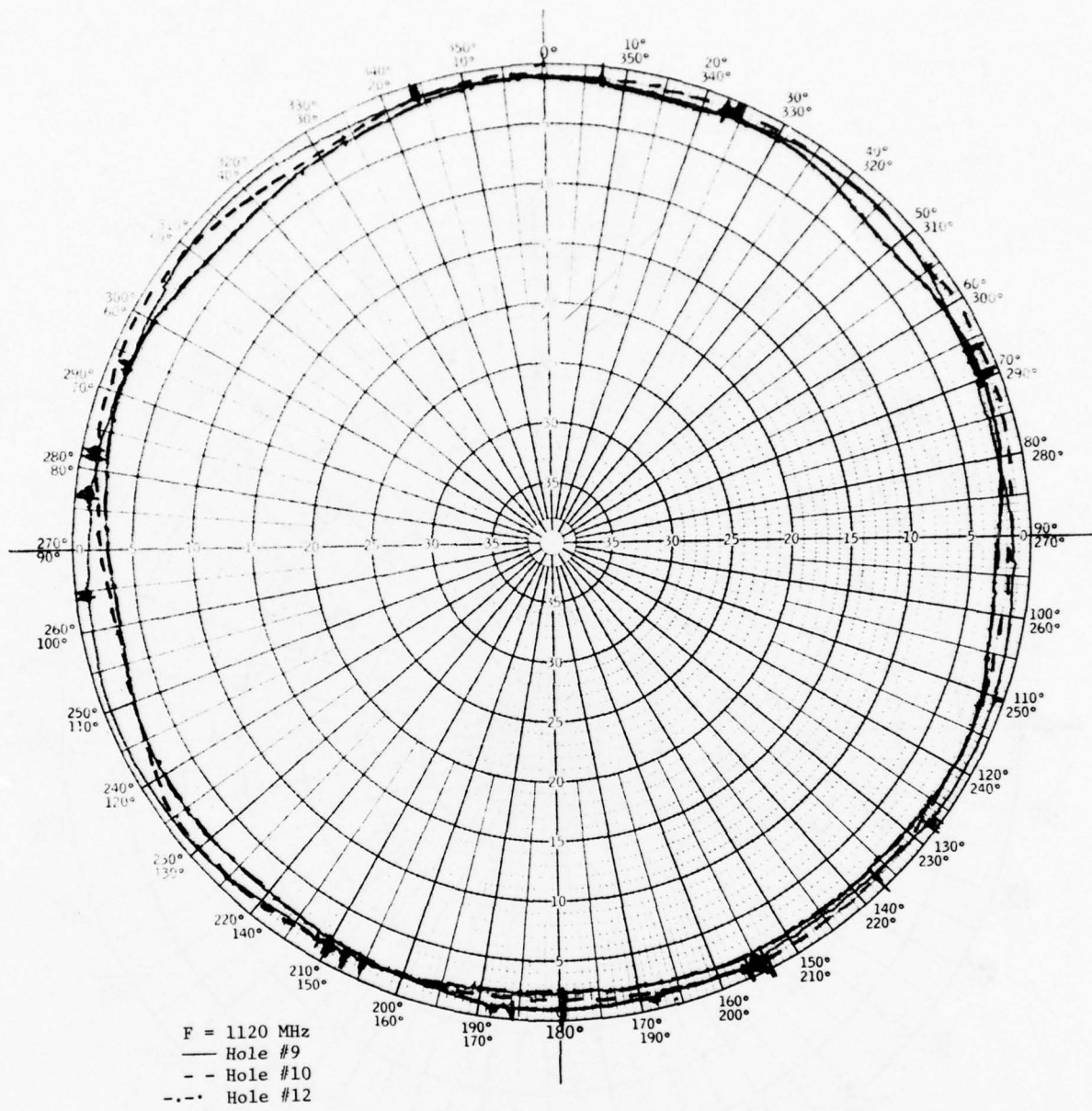

Figure 11. Effect of Mounting Antenna Off-Center.

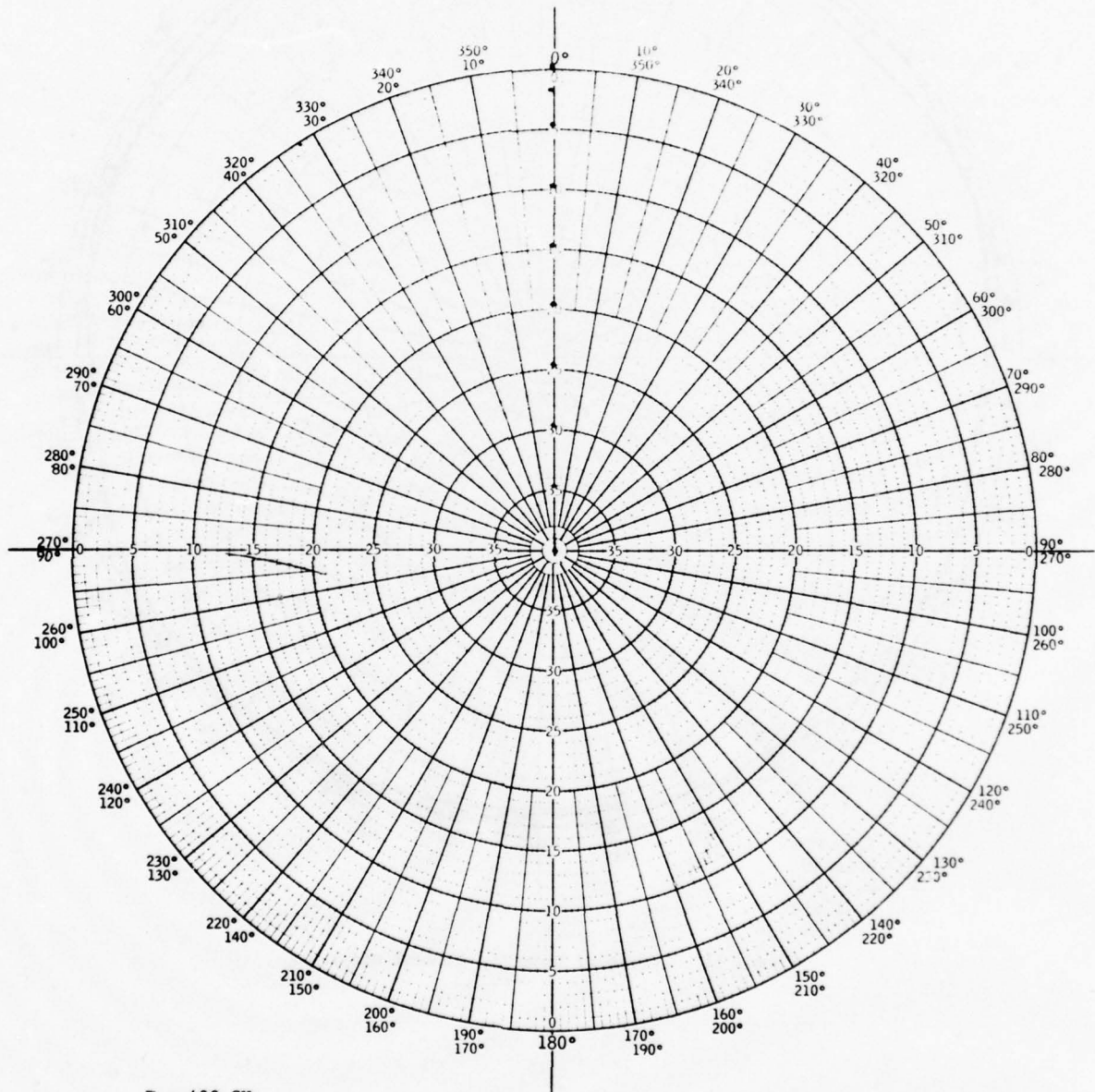

Figure 12. System Calibration.

The actual distance D is 20.3 feet assuring an adequate plane wave illumination.

4. Measurements of the Two Antenna Set Up -- Comparison with the Calculated Results

It was established that for the case of two antennas we would measure a horizontal pattern with one of the antennas receiving the signal from the transmitting antenna and the other either terminated in a 50 ohm load or left open. Normally in any installation all antennas are matched and therefore the 50 ohm termination case should correspond to the common situation in practice. The measurement with the parasite antennas unterminated was carried out to assess this effect. As it will be seen later, it may be very pronounced especially for small antenna separations. Each measurement has, therefore, two plots corresponding to the two cases discussed. It was also decided to orient the antennas in such a way that $\phi = 0^\circ$ corresponds to the line passing through both antennas with the receiving antenna closest to the illuminating source (see Figure 8).

With this convention a horizontal pattern ($\theta = 90^\circ$ zenith angle) and a vertical pattern in the plane $\phi = 0$ was recorded for every antenna position. A problem arose with the vertical patterns since it was not possible to rotate the ground plane a full 180° . It was decided to measure it in two sets of 90° patterns. First the ground plane was set at $\phi = 0$ and the first 90 degrees of θ were measured. Then the ground plane was rotated to 180° (terminated antenna facing the illuminating antenna) and the other 90 degrees of θ were measured. Unfortunately, since the pedestal was not symmetric,

the 180° rotation caused changes in the chamber illuminating field and the two plots do not coincide for $\theta = 0$ (zenith). As we were interested only in the general effect of the edge diffraction, this was not considered too serious. However, it invalidates the data for high elevation angles.

The measurements are shown in Figures 13 through 26.

The corresponding computed results are shown by x's marked on the pattern. They should be compared with the case where the parasite antenna is terminated since they were calculated under this hypothesis (solid line). As the computed results are always normalized to 0 dB in the cases where the measured pattern did not reach the 0 dB level, the computed results were denormalized usually to the maximum value of the measured pattern.

It is seen that the computed values are very close to the measured ones. Even when deviations occurred, they seldom exceeded 1.5 dB and the calculated pattern had all the indentations of the measured at the correct places. A few of the measurements exceeded the 0 dB level and therefore a compression may or may not have occurred. Usually these are the patterns that present the highest deviations between the computed and measured results.

In the case of the vertical patterns it is seen that the calculated and measured results are far apart as should be expected. However, for low elevation angles, the pattern is approximately that of a monopole on both the measured and computed cases and, therefore, the results are still close when a proper normalization factor is applied.

For the case of two antennas the measurements for 0.5λ and 0.75λ separation were performed on two different dates (19/8 and 22/8) during initial

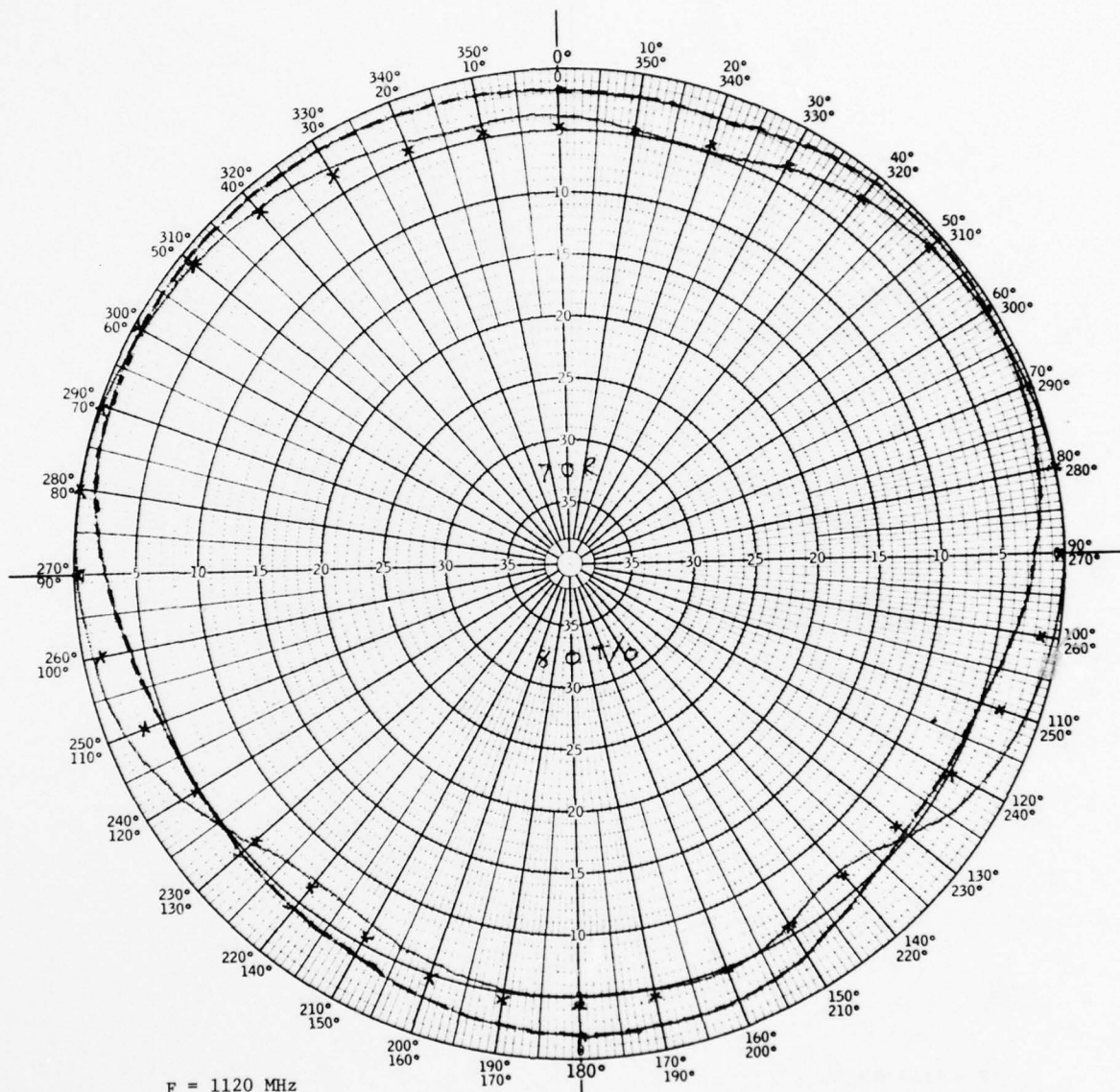
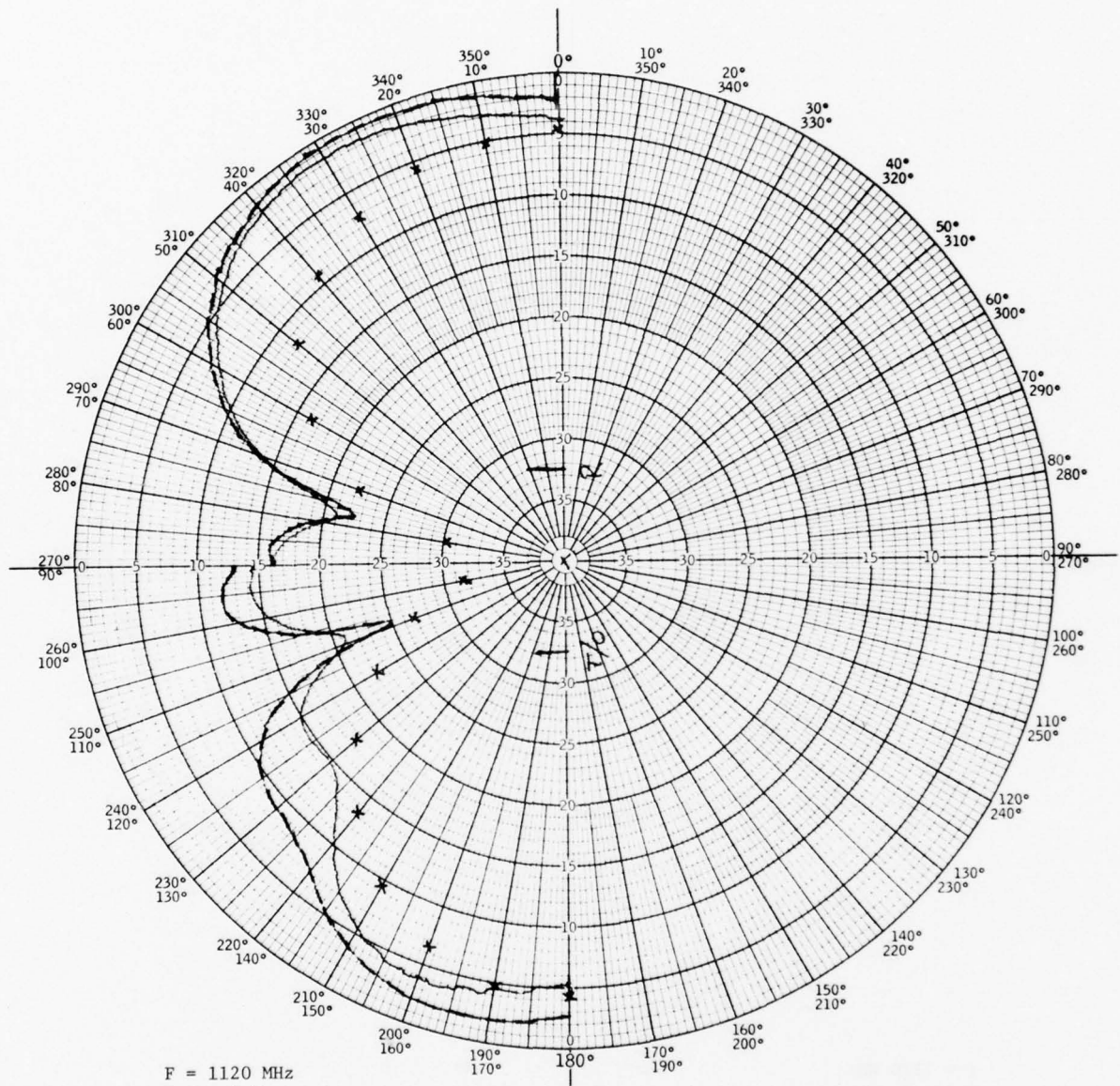

Figure 13. Two Antenna Horizontal Pattern $\approx 0.5\lambda$ Spacing.



F = 1120 MHz
 Holes 7,8
 — Terminated
 - - Open
 x Computed

Figure 14. Two Antenna Vertical Pattern $\sim 0.5\lambda$ Spacing.

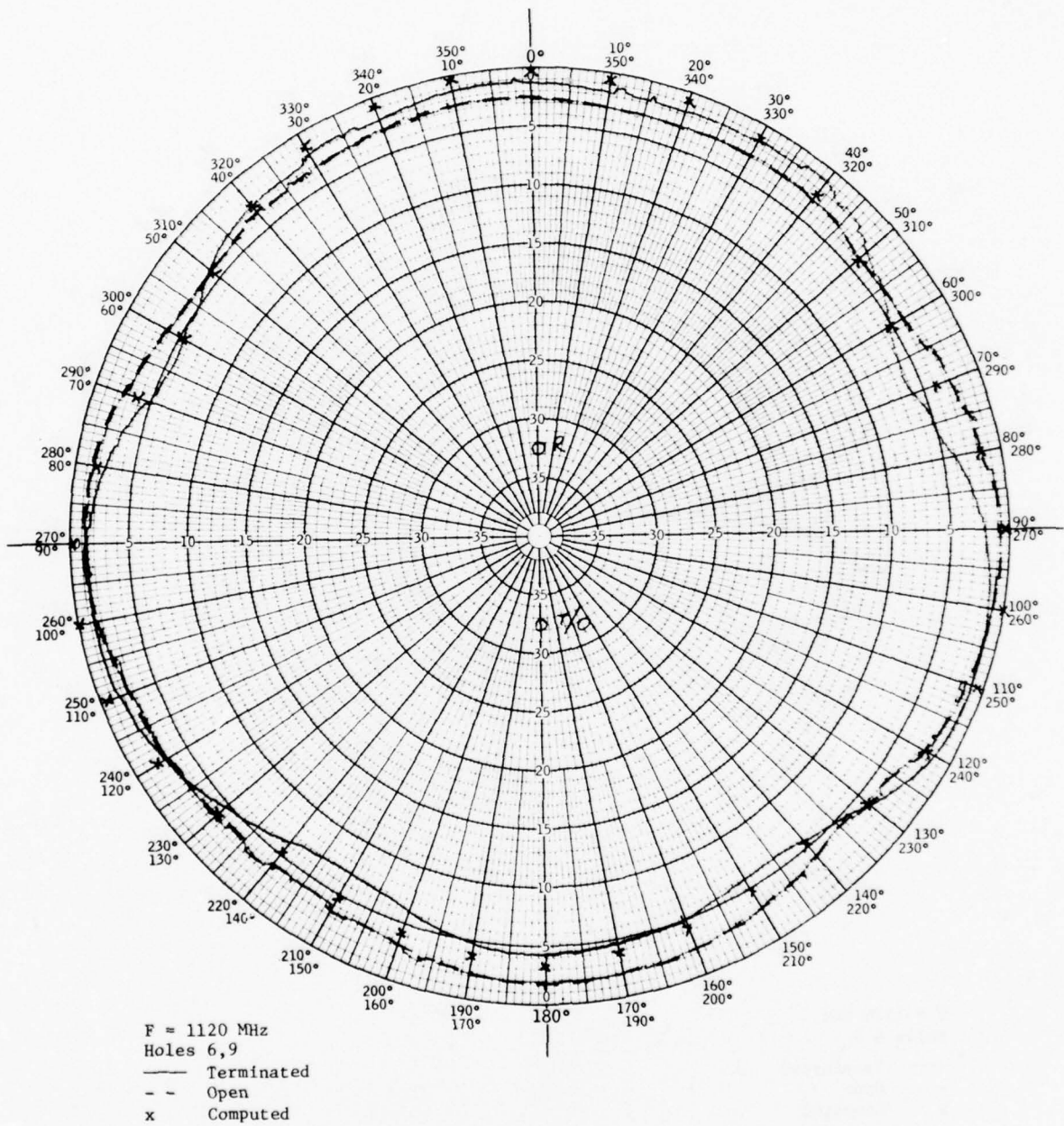

Figure 15. Two Antenna Horizontal Pattern $\sim 0.75\lambda$ Spacing.

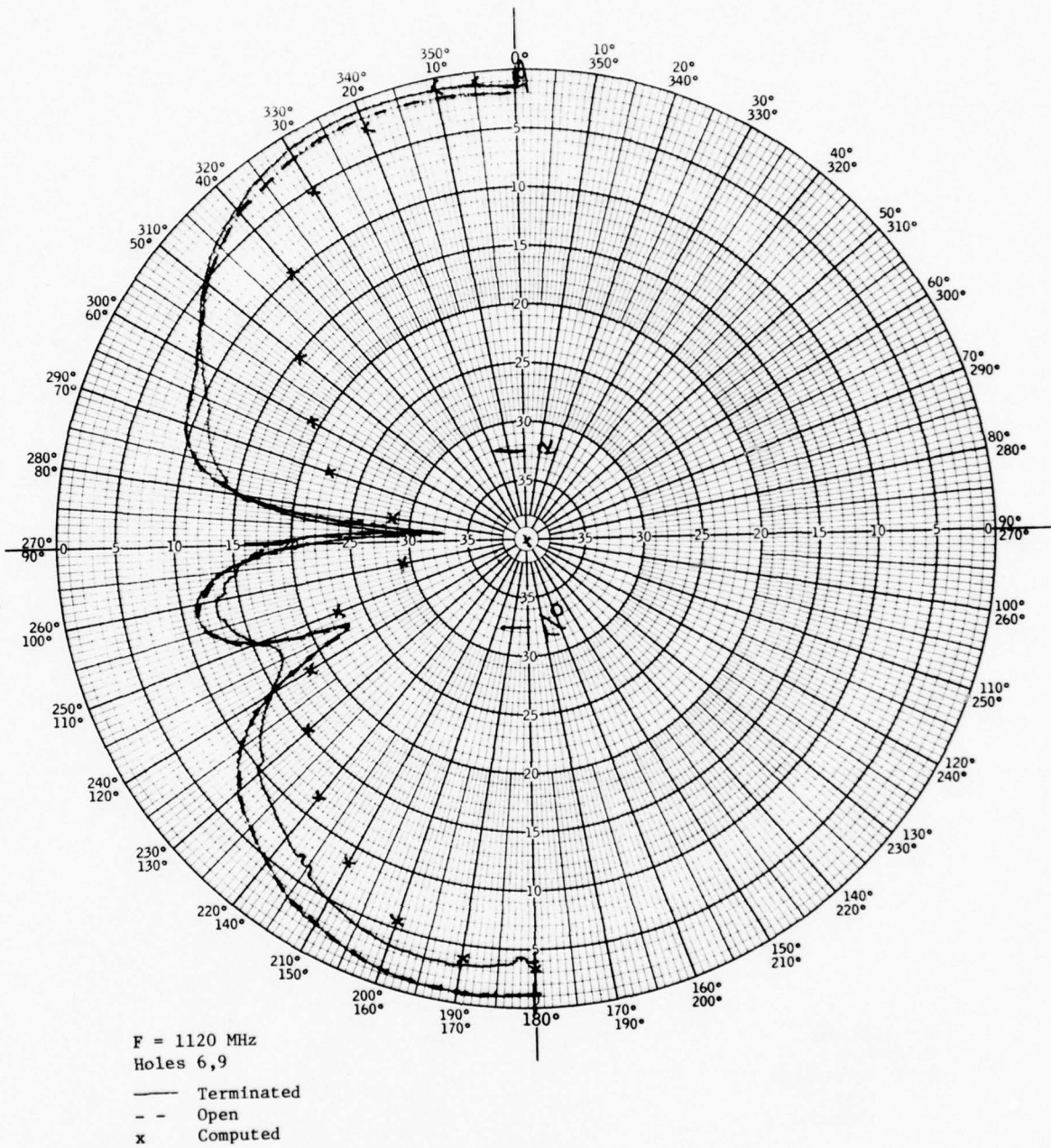

Figure 16. Two Antenna Vertical Pattern $\sim 0.75\lambda$ Spacing.

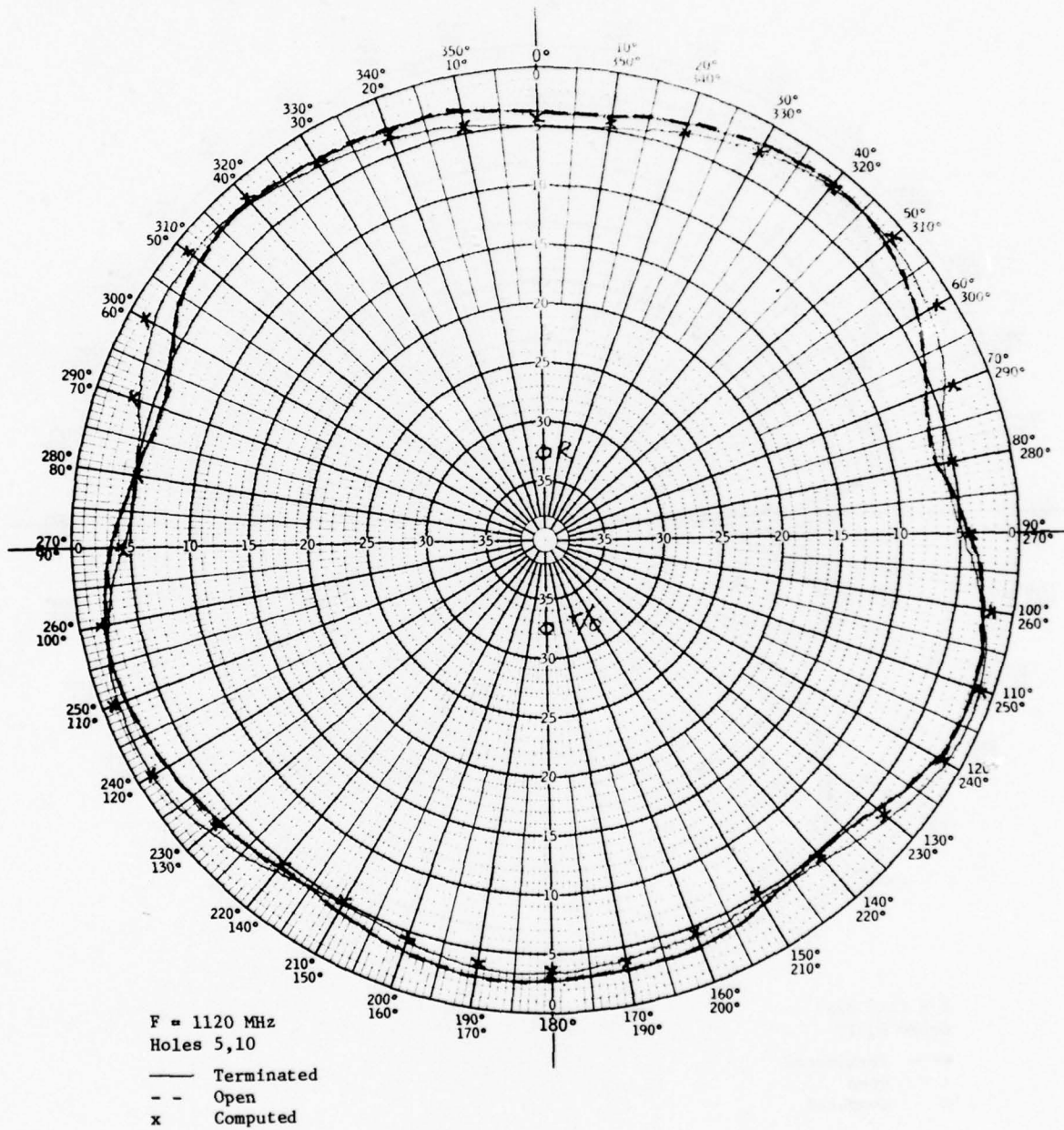

Figure 17. Two Antenna Horizontal Pattern $\sim 1.0\lambda$ Spacing.

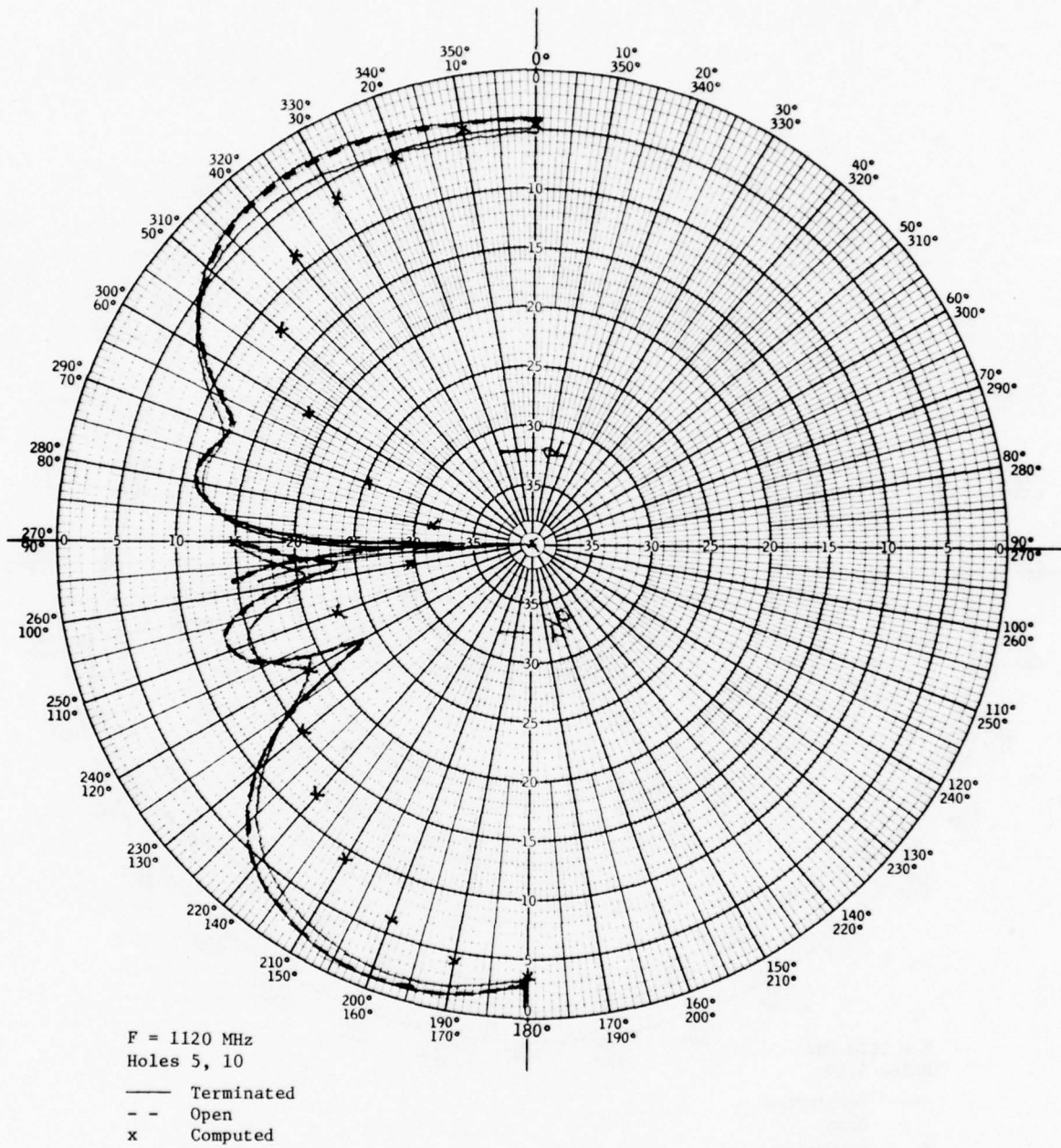
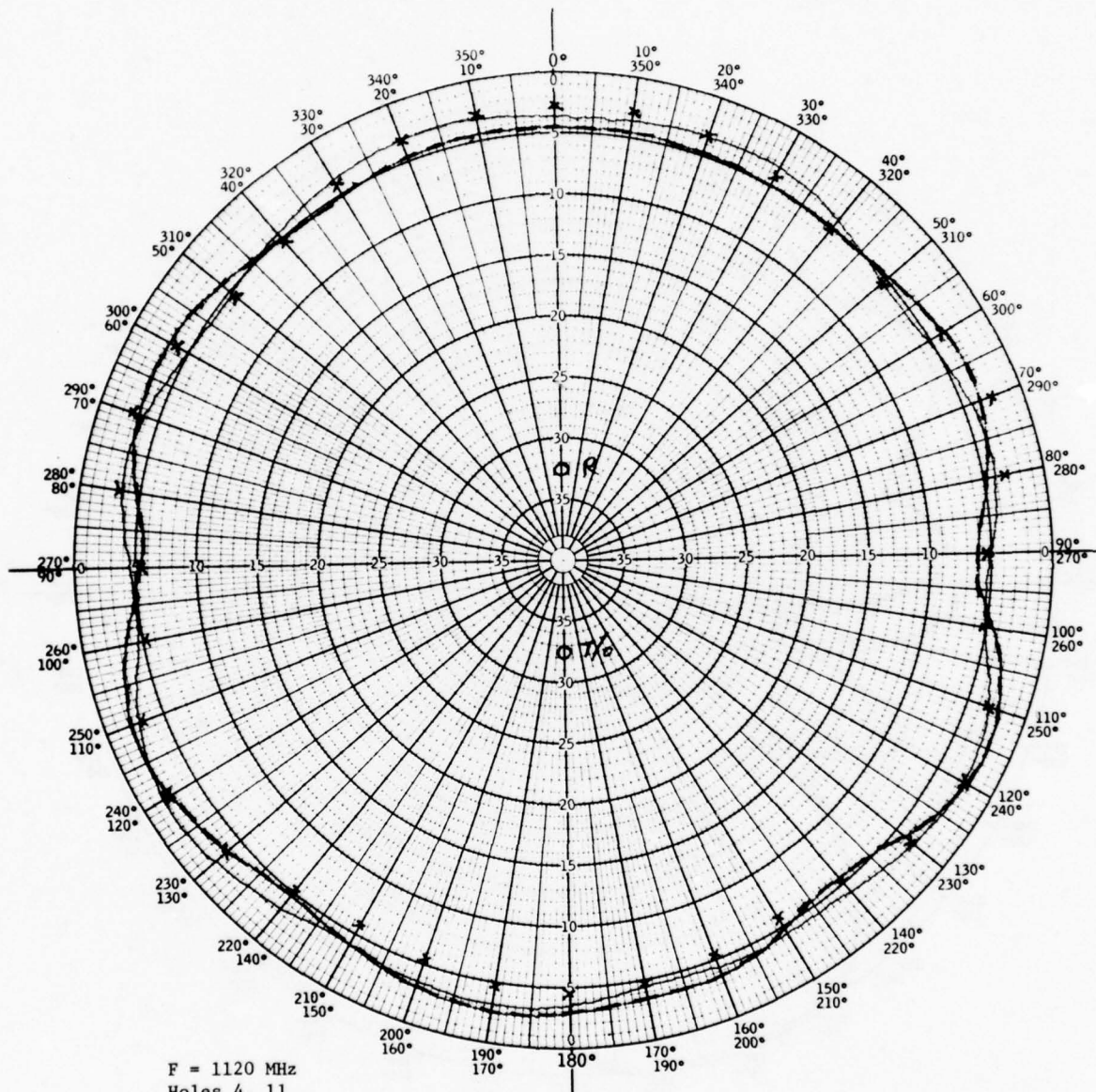
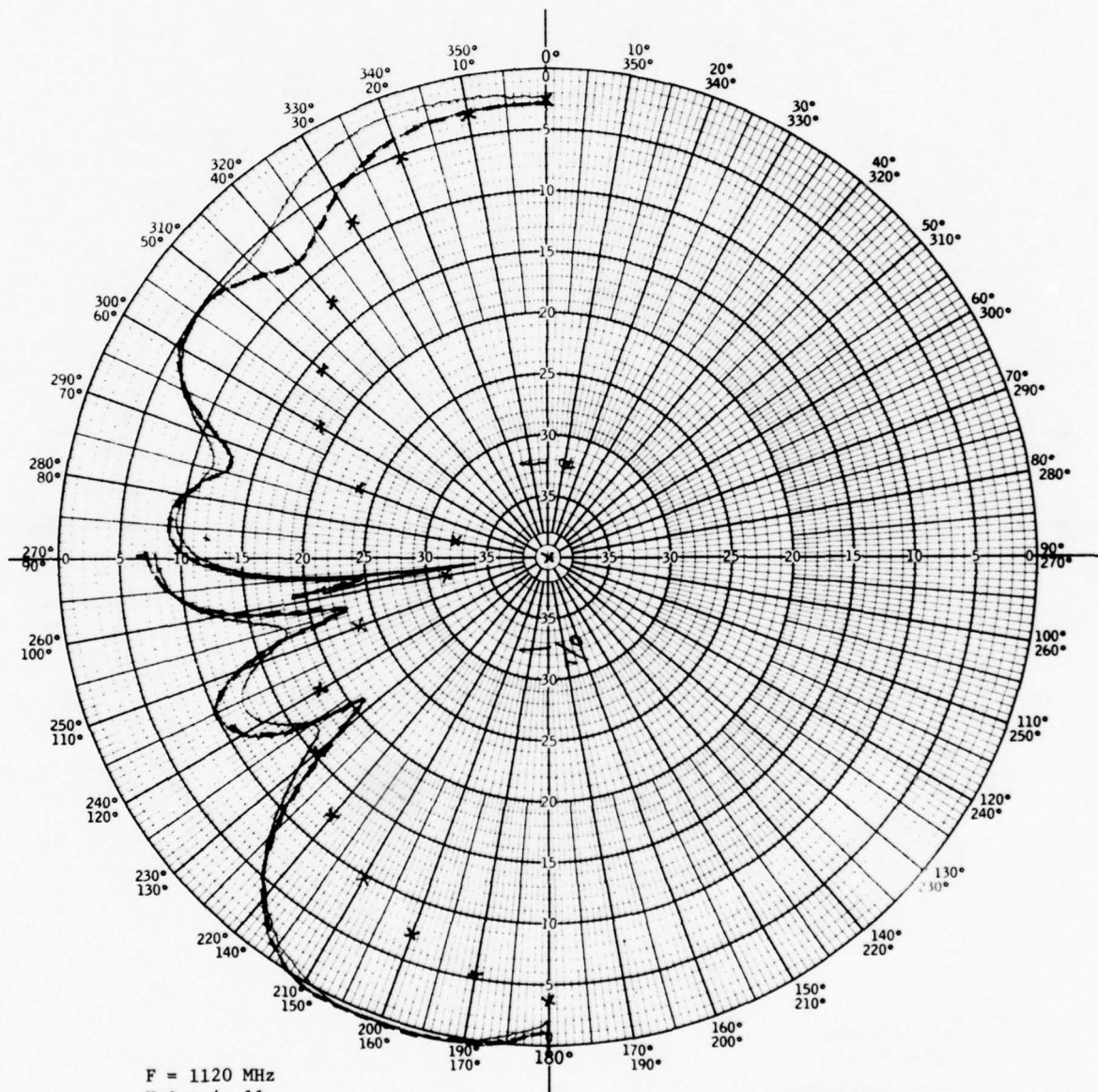

Figure 18. Two Antenna Vertical Pattern $\sim 1.0\lambda$ Spacing.



F = 1120 MHz
 Holes 4, 11
 — Terminated
 - - Open
 x Computed

Figure 19. Two Antenna Horizontal Pattern $\sim 1.25\lambda$ Spacing.



F = 1120 MHz
 Holes 4, 11
 — Terminated
 - - Open
 x Computed

Figure 20. Two Antenna Vertical Pattern $\sim 1.25\lambda$ Spacing.

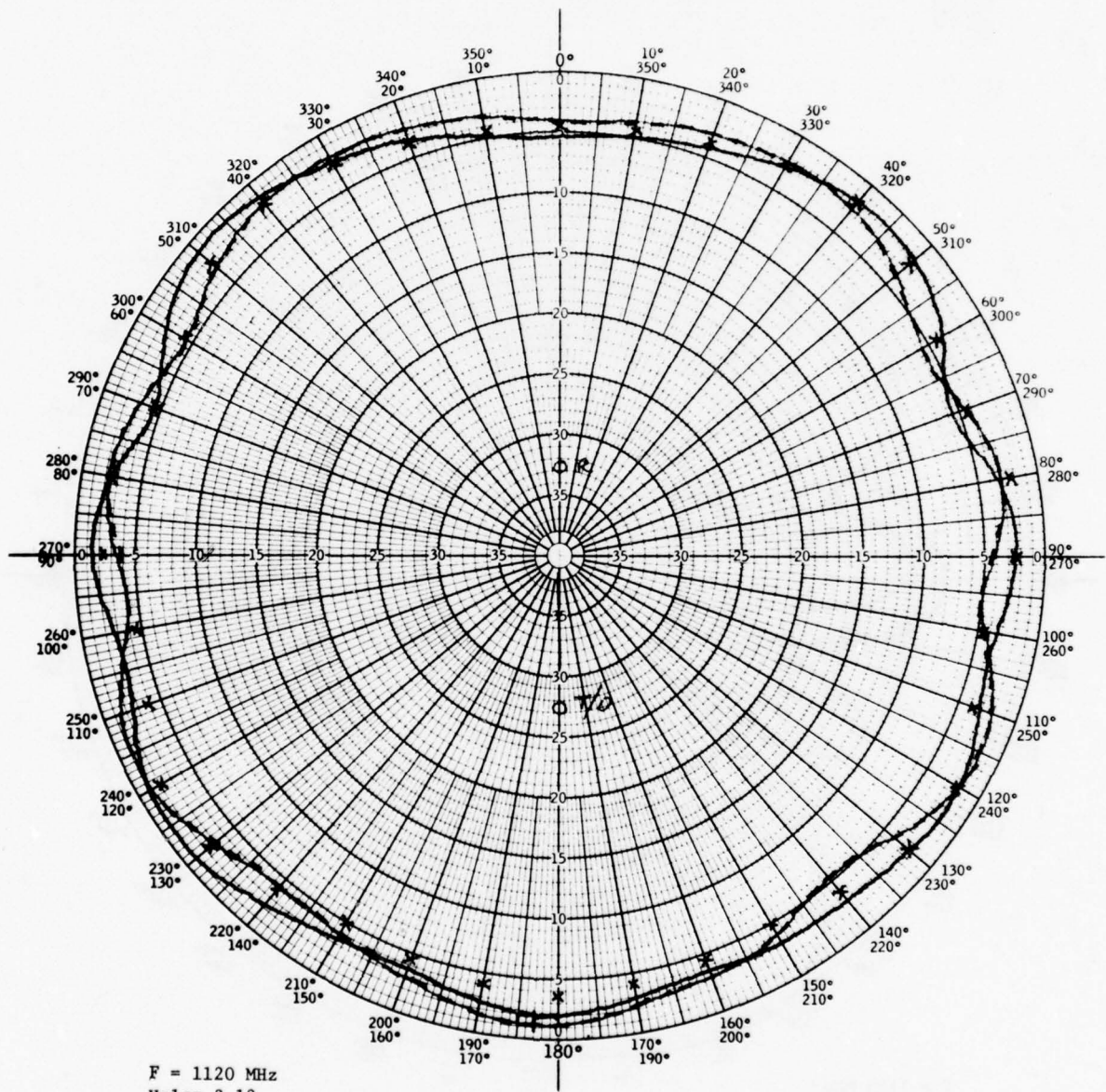

Figure. 21. Two Antenna Horizontal Pattern $\approx 1.5\lambda$ Spacing.

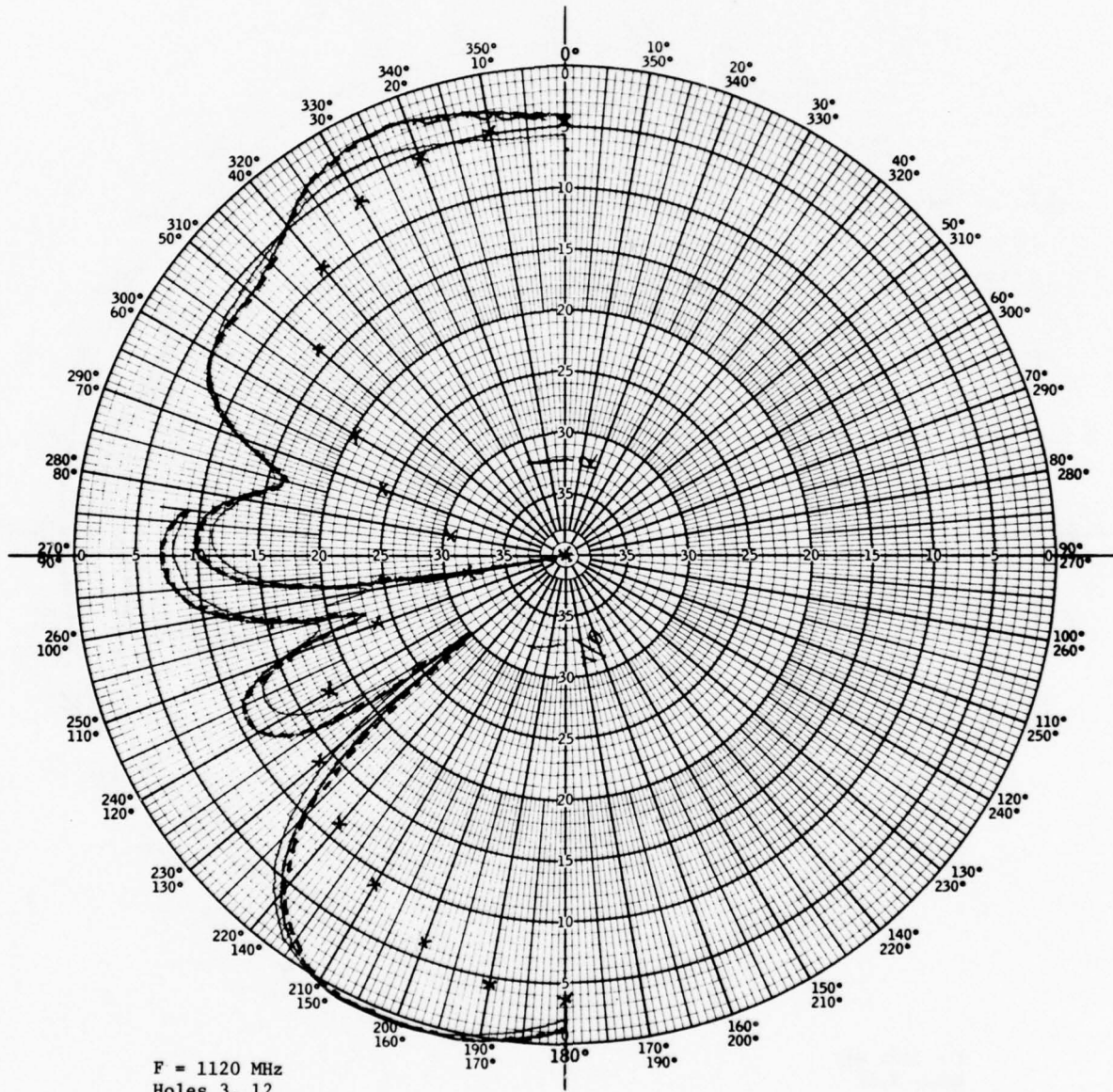
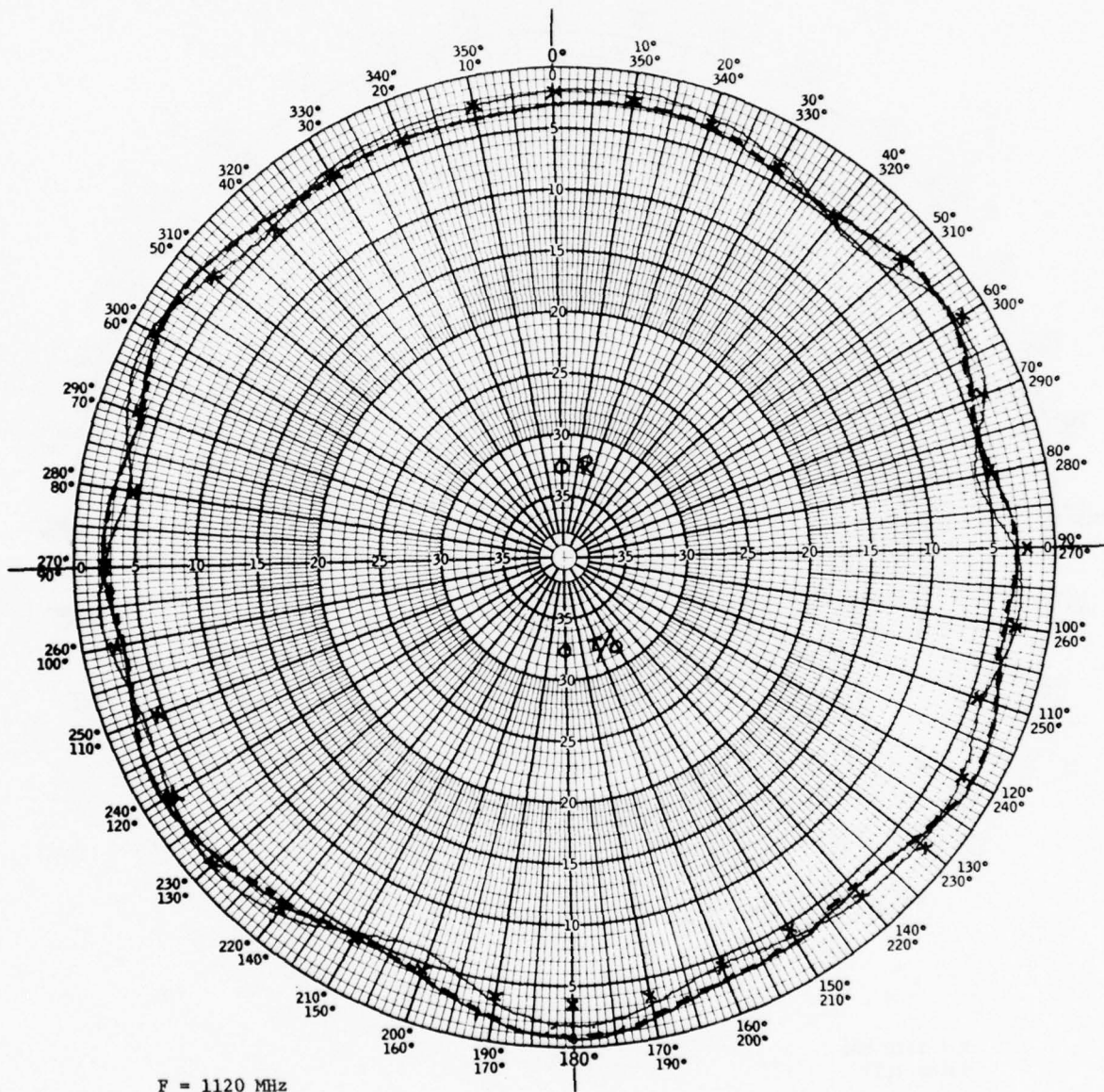
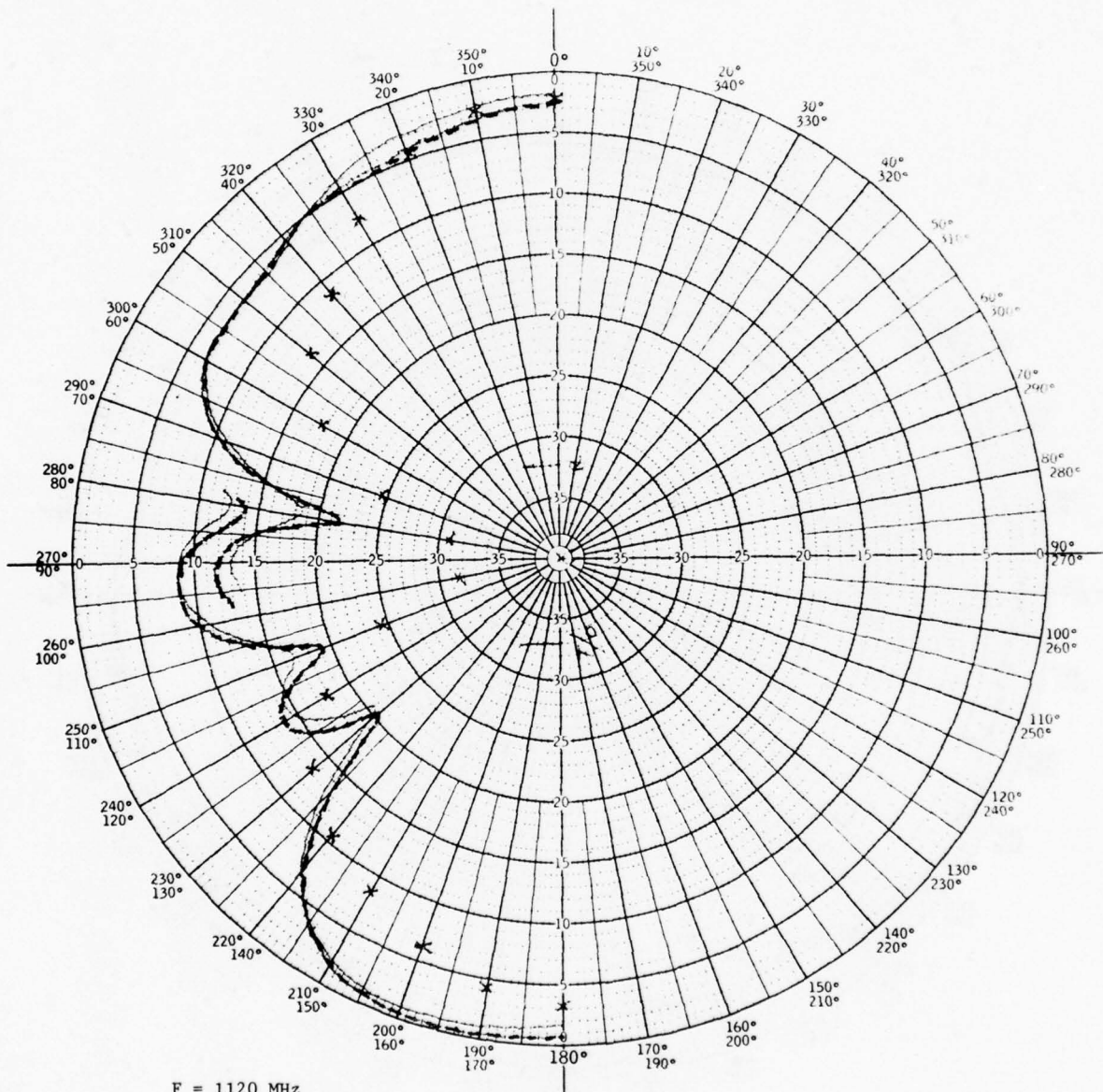

Figure 22. Two Antenna Vertical Pattern $\sim 1.5\lambda$ Spacing.



F = 1120 MHz
 Holes 2, 13
 — Terminated
 - - Open
 x Computed

Figure 23. Two Antenna Horizontal Pattern $\sim 1.75\lambda$ Spacing.



F = 1120 MHz
 Holes 2,13

— Terminated
 - - Open
 x Computed

Figure 24. Two Antenna Vertical Pattern $\sim 1.75\lambda$ Spacing.

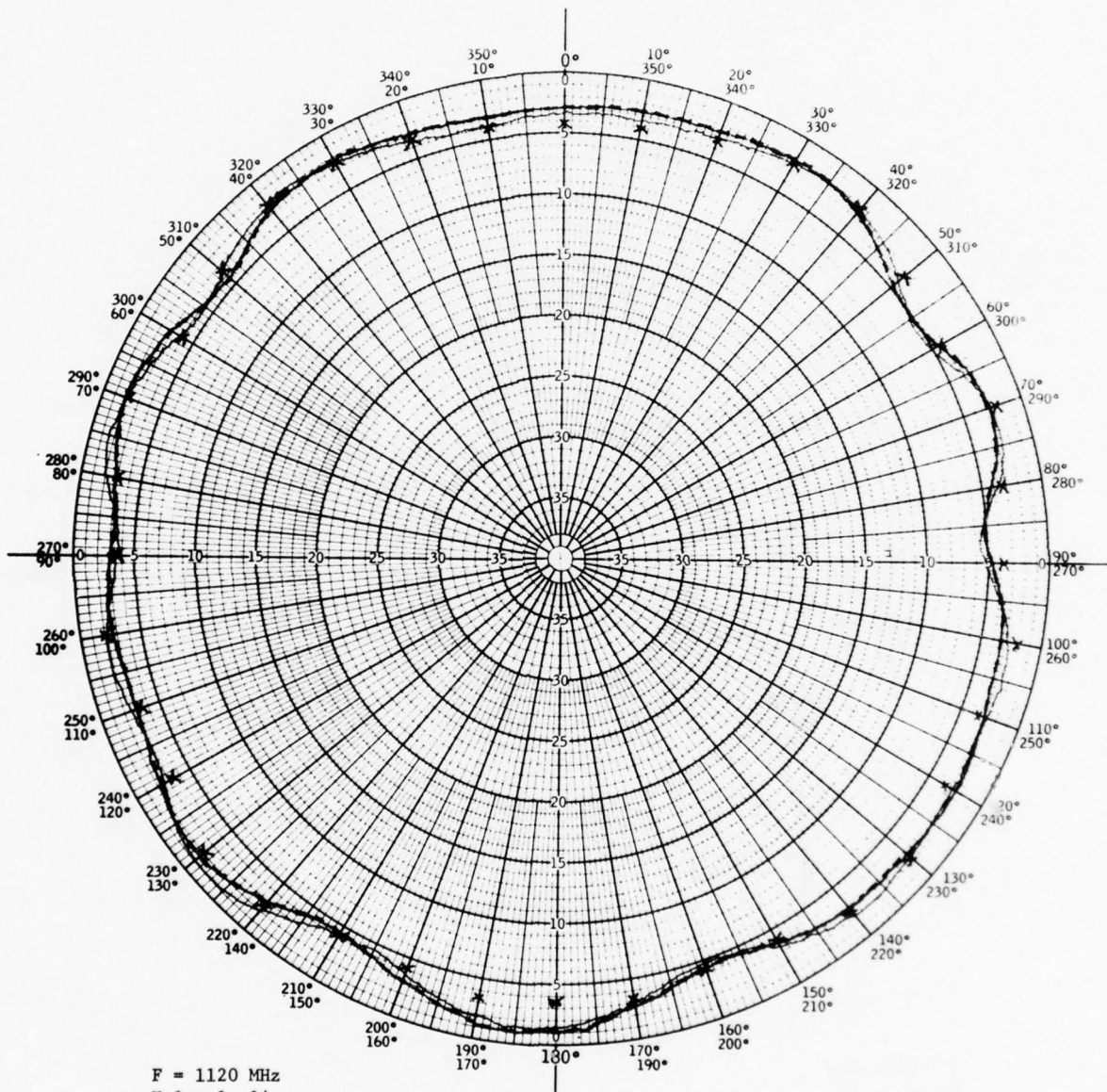

Figure 25. Two Antenna Horizontal Pattern $\sim 2.0\lambda$ Spacing.

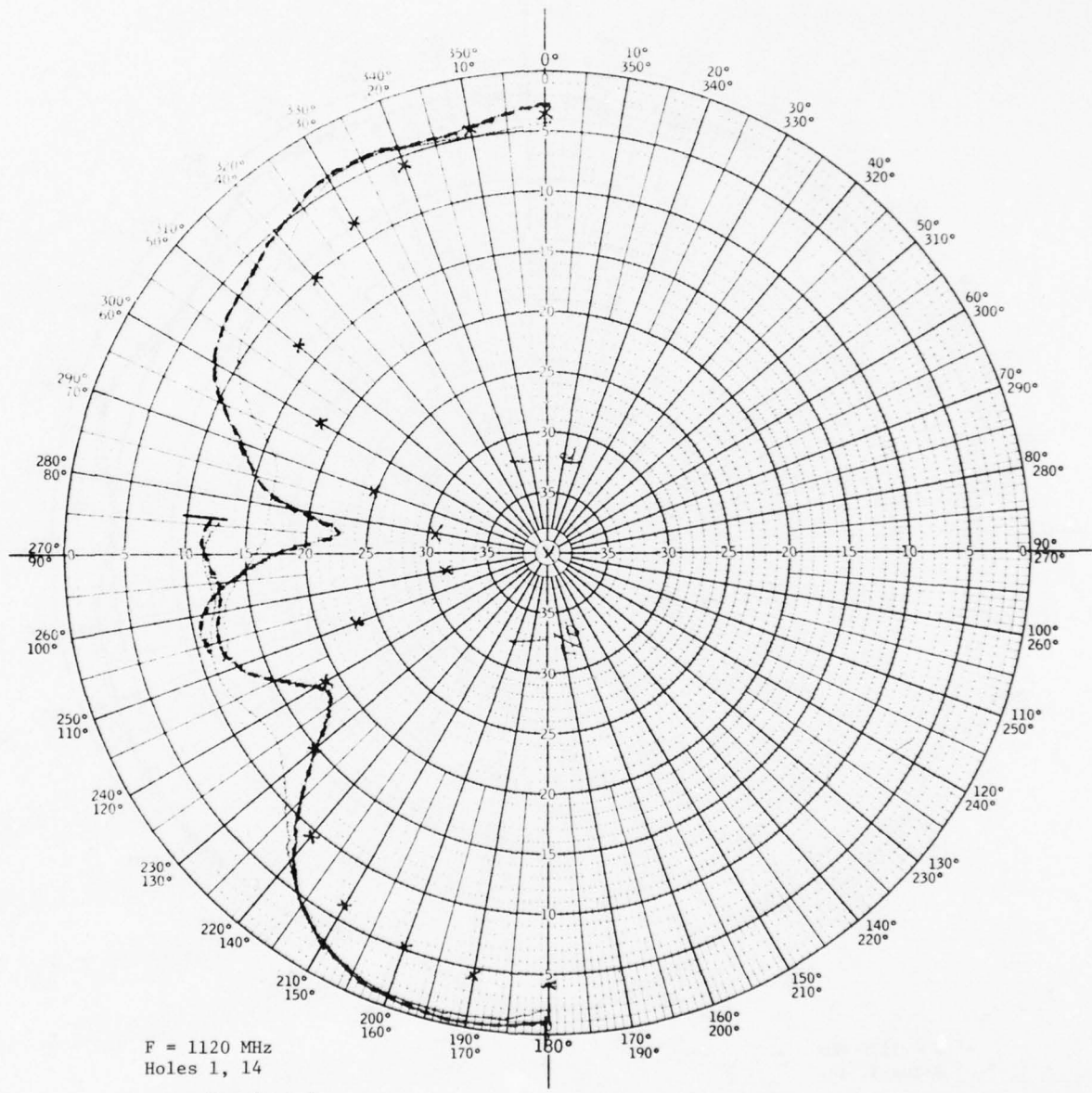

Figure 26. Two Antenna Vertical Pattern $\sim 2.0\lambda$ Spacing.

trial runs. The two measurements differ somewhat and are shown in Figures 27 and 28 with the calculated values represented by the x's. It is interesting to note that for the most part the x's fall between both curves. This seems to indicate that the calculation is within the measurement accuracy.

Other factors which may have contributed to the discrepancies are

1. As shown in Figures 10 and 11, the radiation pattern of each antenna is not a circle and depends on its position on the ground plane.
2. Changes in the illuminating field across the chamber. This is indicated by the lack of absolute symmetry of the horizontal patterns along the $\phi = 0.180^\circ$ line.
3. Influence of the pedestal in the illuminating field. This is clearly seen in the vertical pattern measurements.

5. Measurements of the Four Antenna Set-up -- Comparison with Calculated Results

The references for the four antenna measurements are shown in Figure 9. The antenna at $\phi = 315^\circ$ was the receiving antenna. The others were either all terminated with 50 ohms or left open. Vertical patterns were measured at the $\phi = 0^\circ$ plane.

The measured and computed results are shown in Figures 29 through 42. The calculated results are shown by x's as in the case of two antennas.

The same remarks previously made for the two antenna case can be made here.

The agreement between the measured and computed results is, we believe, within the accuracy of the measurements.

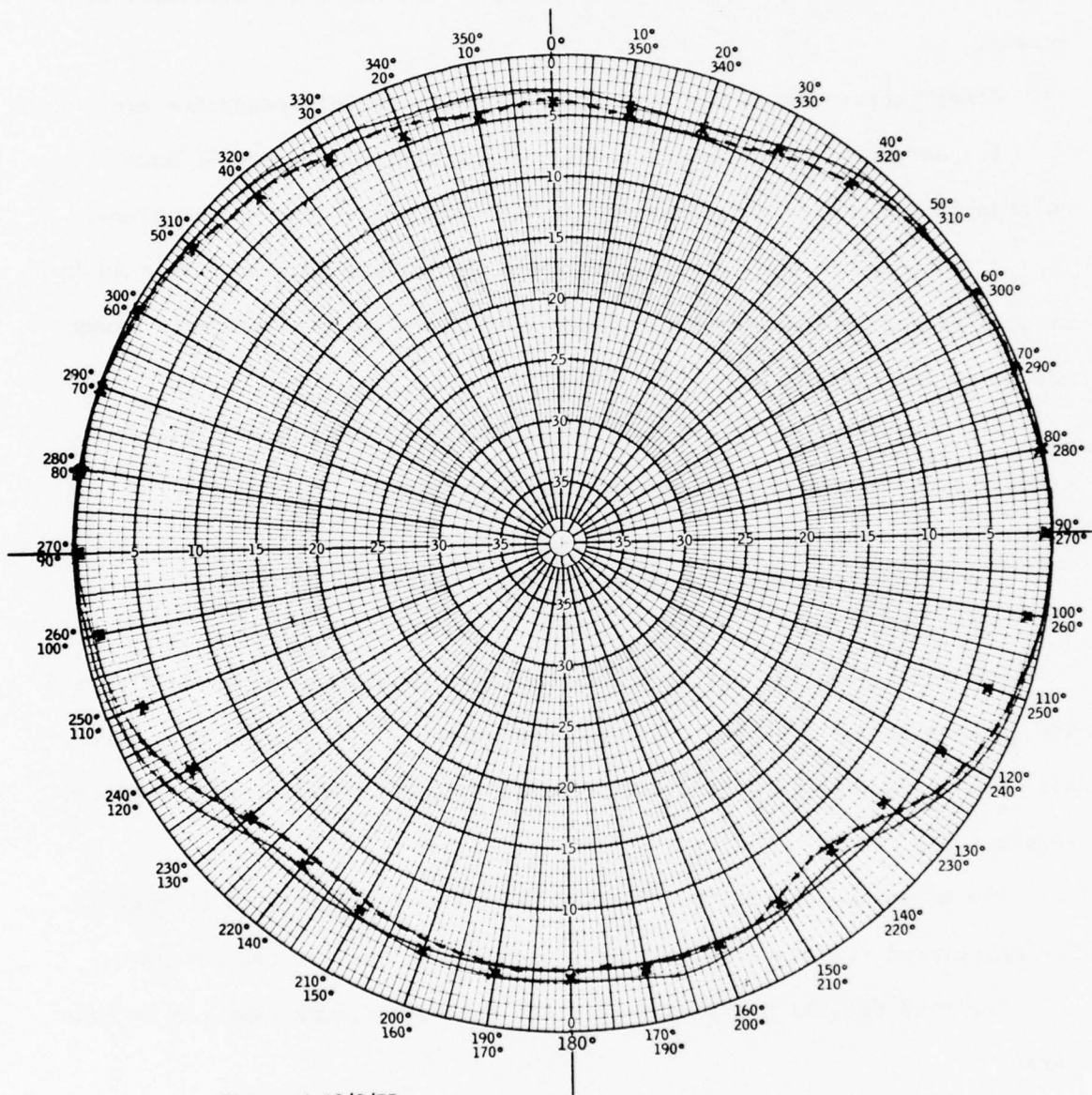

- - - Measured 19/8/77
- Measured 22/8/77
- x Computed

Figure 27. Measurement at Two Different Dates - Two Antenna Horizontal Pattern $\sim 0.5\lambda$ Separation.

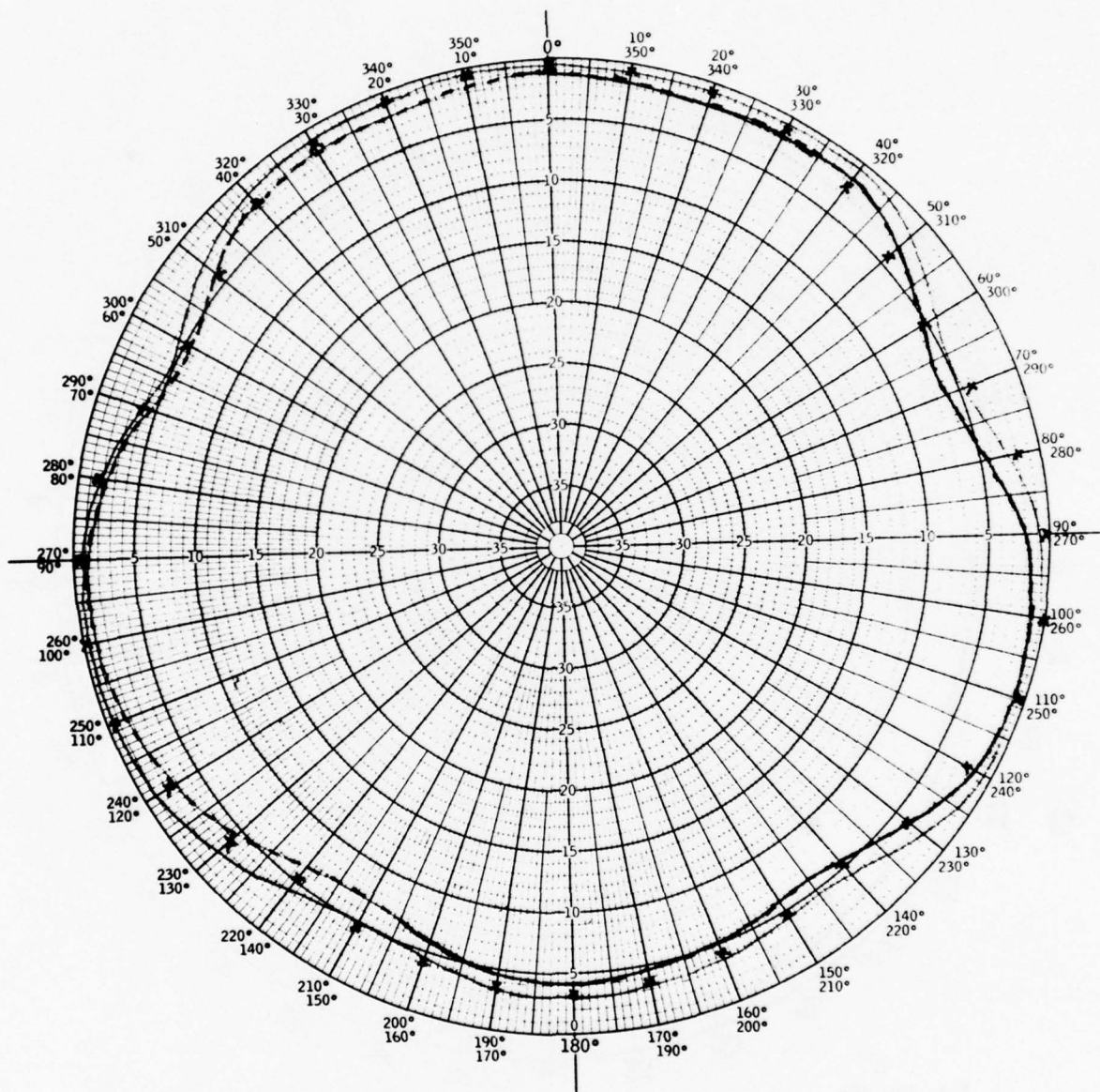

- - - Measured 19/8/77
 ——— Measured 22/8/77
 x Computed

Figure 28. Measurement at Two Different Dates - Two Antenna Horizontal Pattern $\sim 0.75\lambda$ Separation.

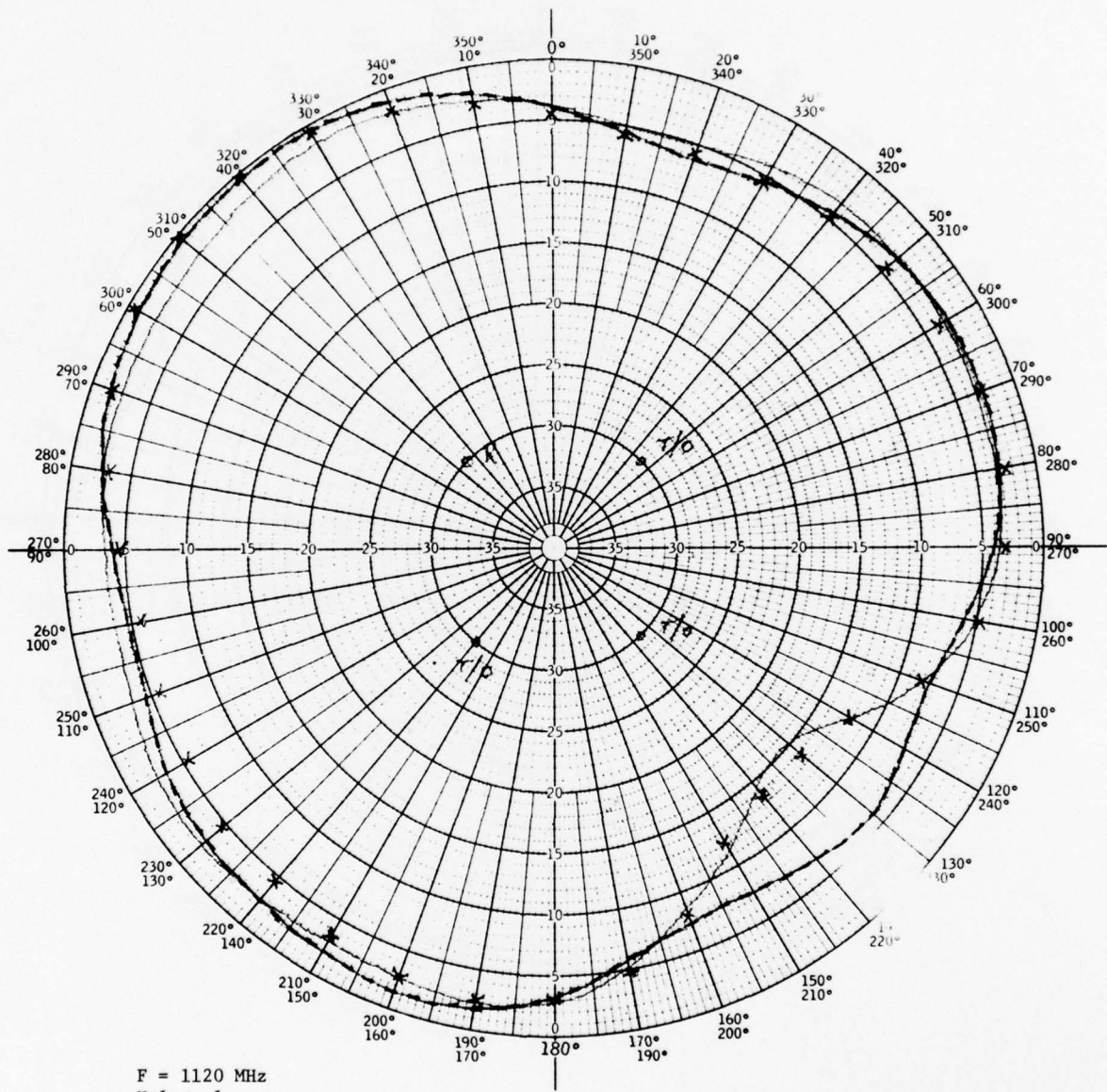

Figure 29. Four Antenna Horizontal Pattern $\sim 0.5\lambda$ Spacing.

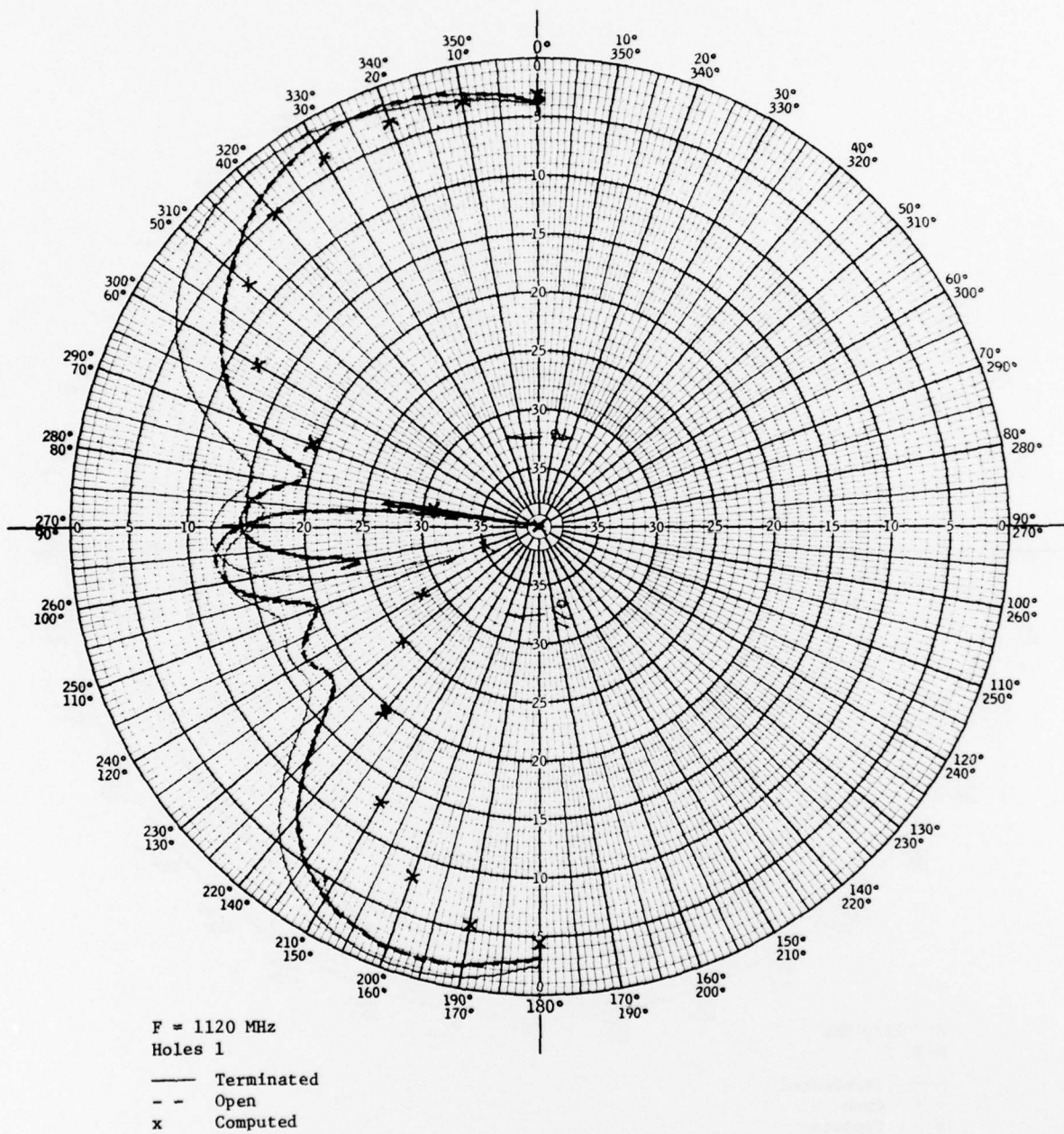

Figure 30. Four Antenna Vertical Pattern $\approx 0.5\lambda$ Spacing.

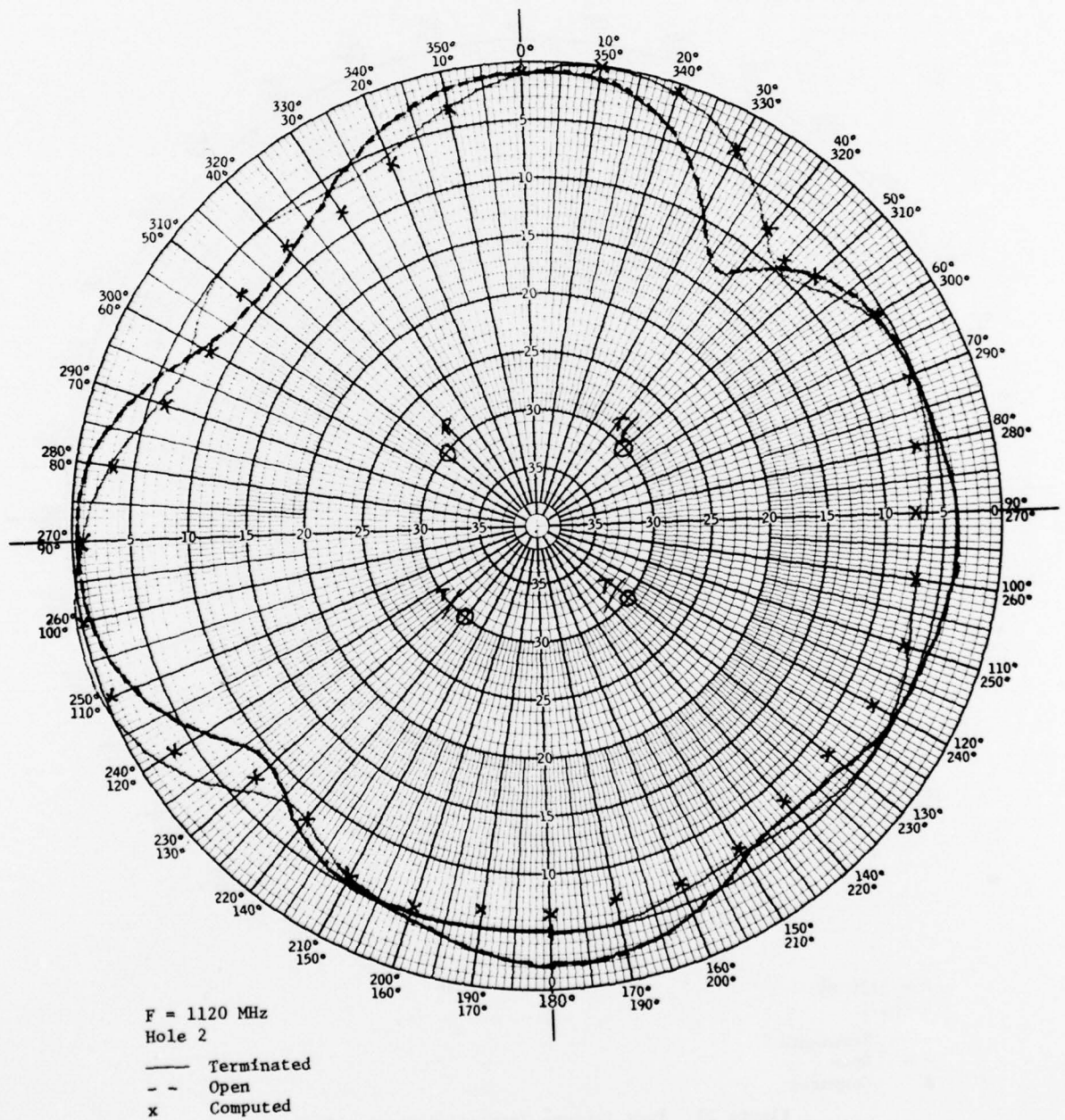

Figure 31. Four Antenna Horizontal Pattern $\sim 0.75\lambda$ Spacing.

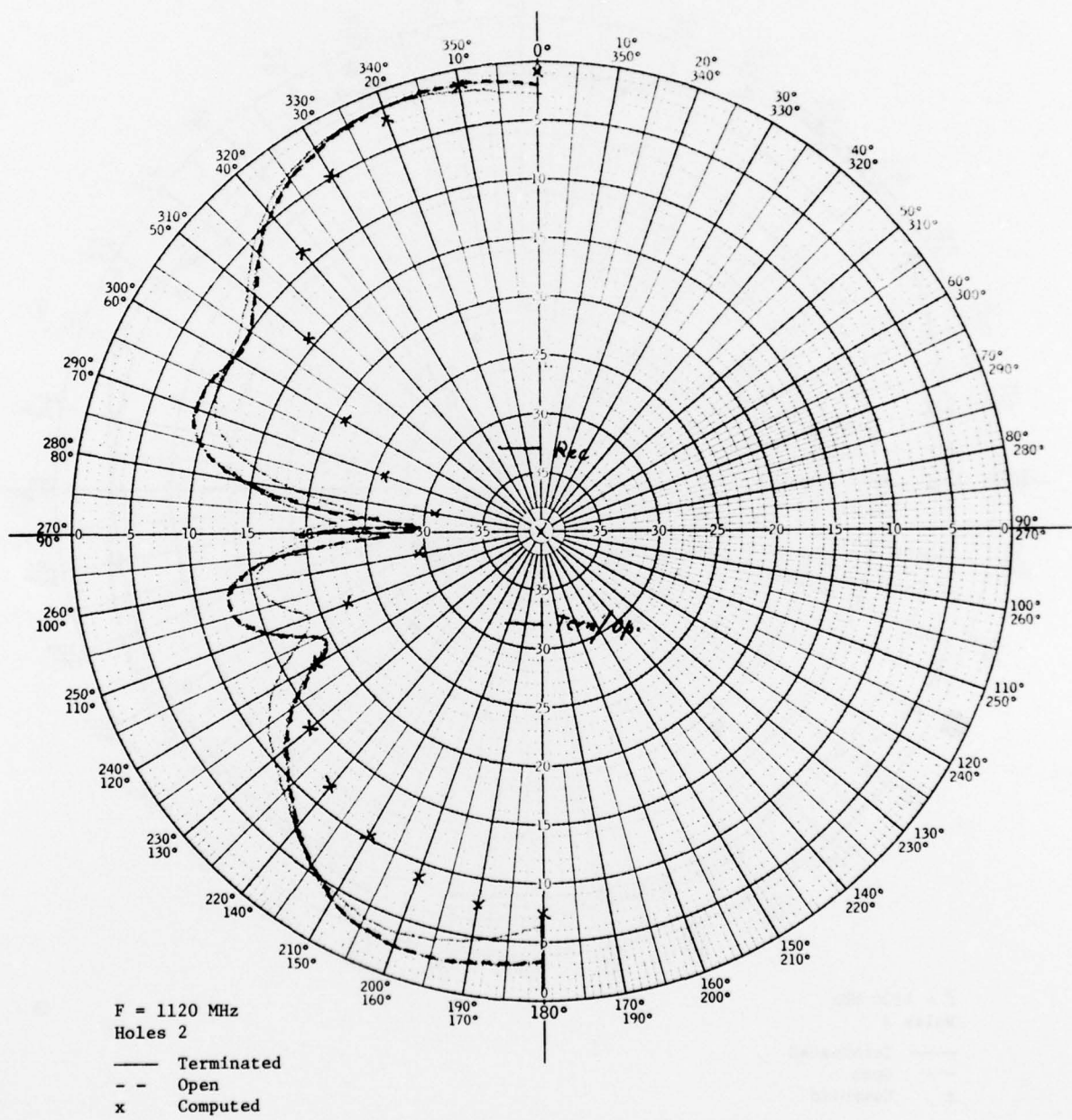
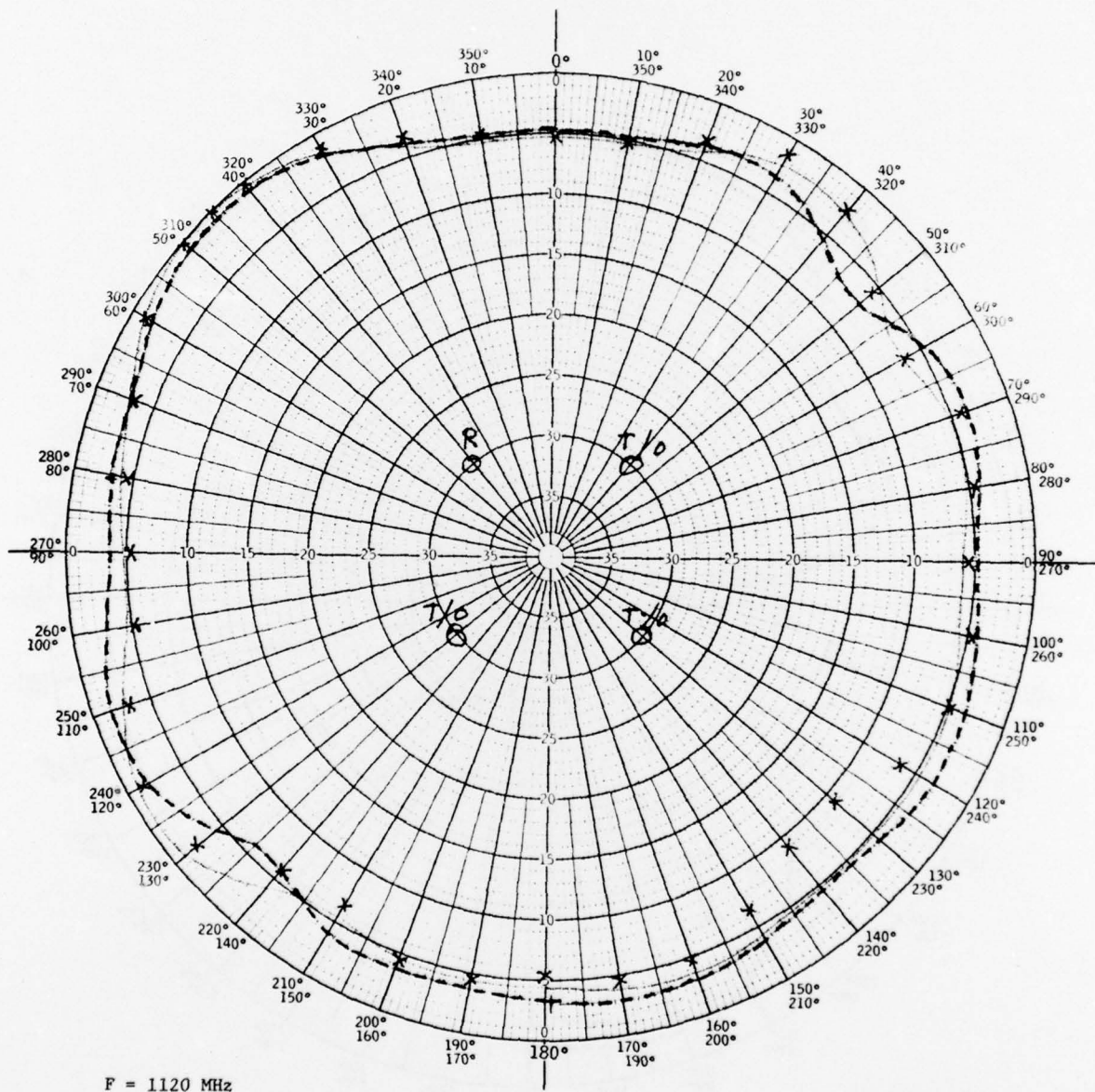

Figure 32. Four Antenna Vertical Pattern $\sim 0.75\lambda$ Spacing.



F = 1120 MHz
 Holes 3
 — Terminated
 - - Open
 x Computed

Figure 33. Four Antenna Horizontal Pattern $\sim 1.0\lambda$ Spacing.

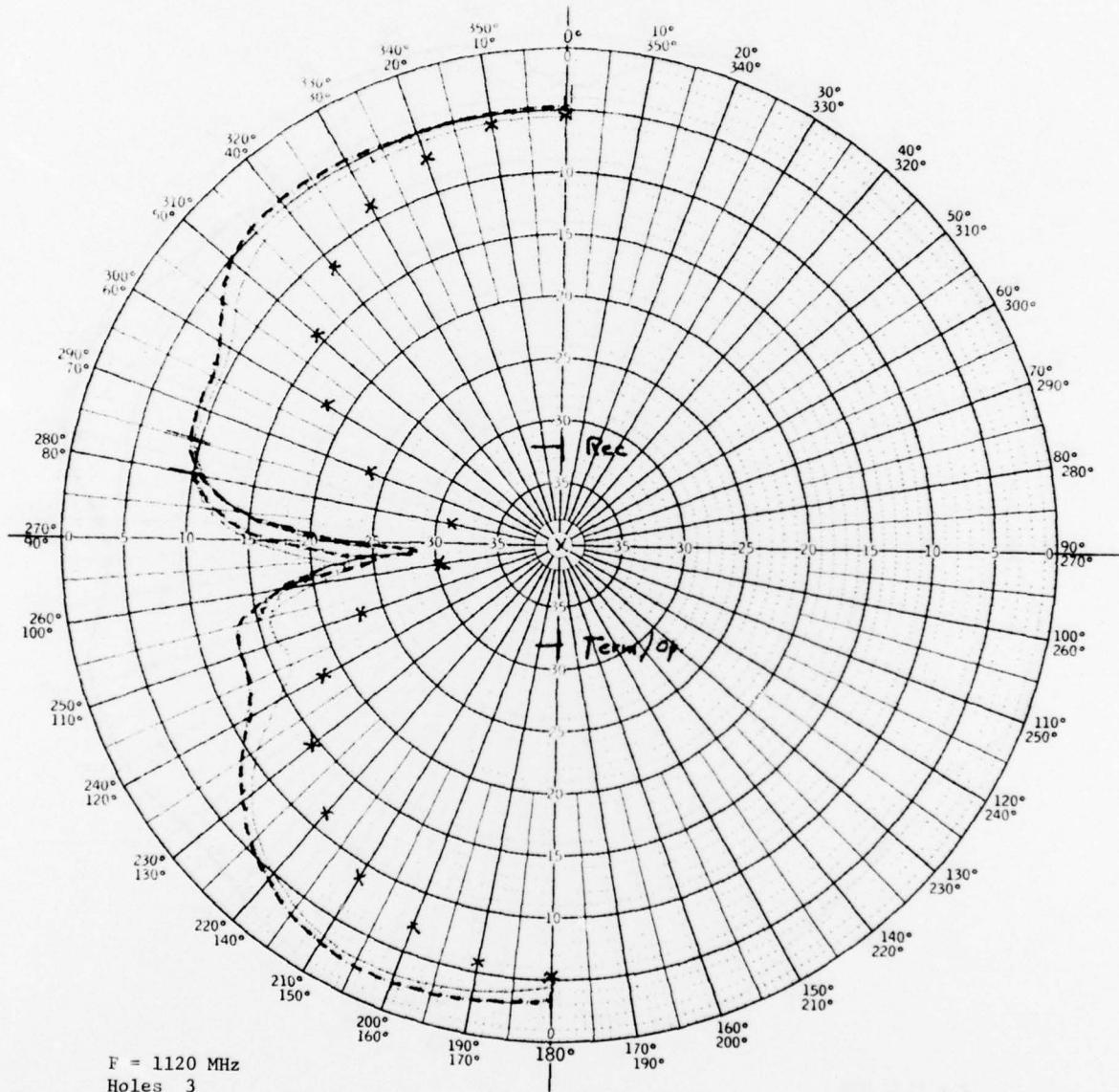
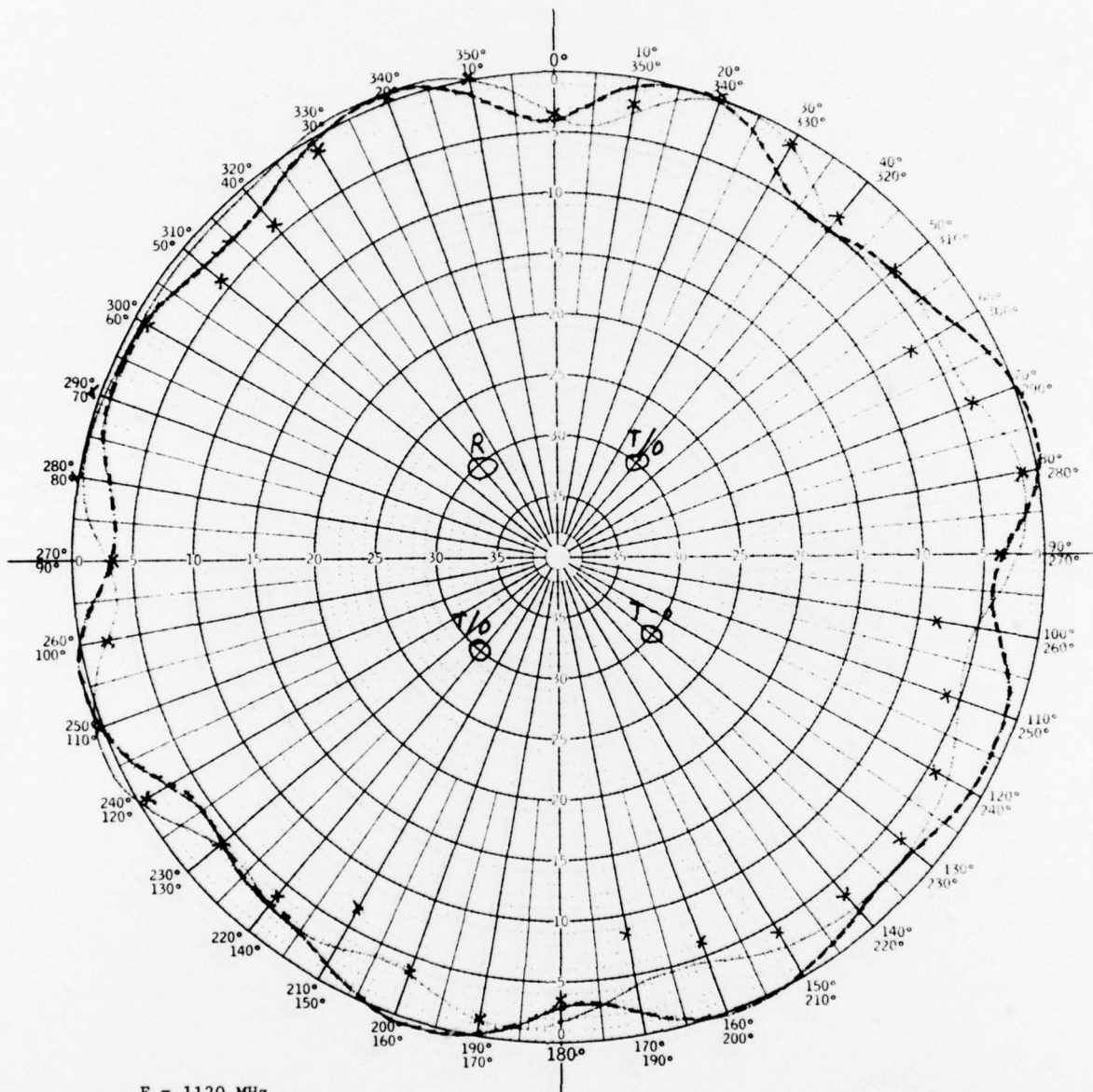

Figure 34. Four Antenna Vertical Pattern $\sim 1.0\lambda$ Spacing.



F = 1120 MHz
 Holes 4
 — terminated
 - - Open
 x Computed

Figure 35. Four Antenna Horizontal Pattern $\approx 1.25\lambda$ Spacing.

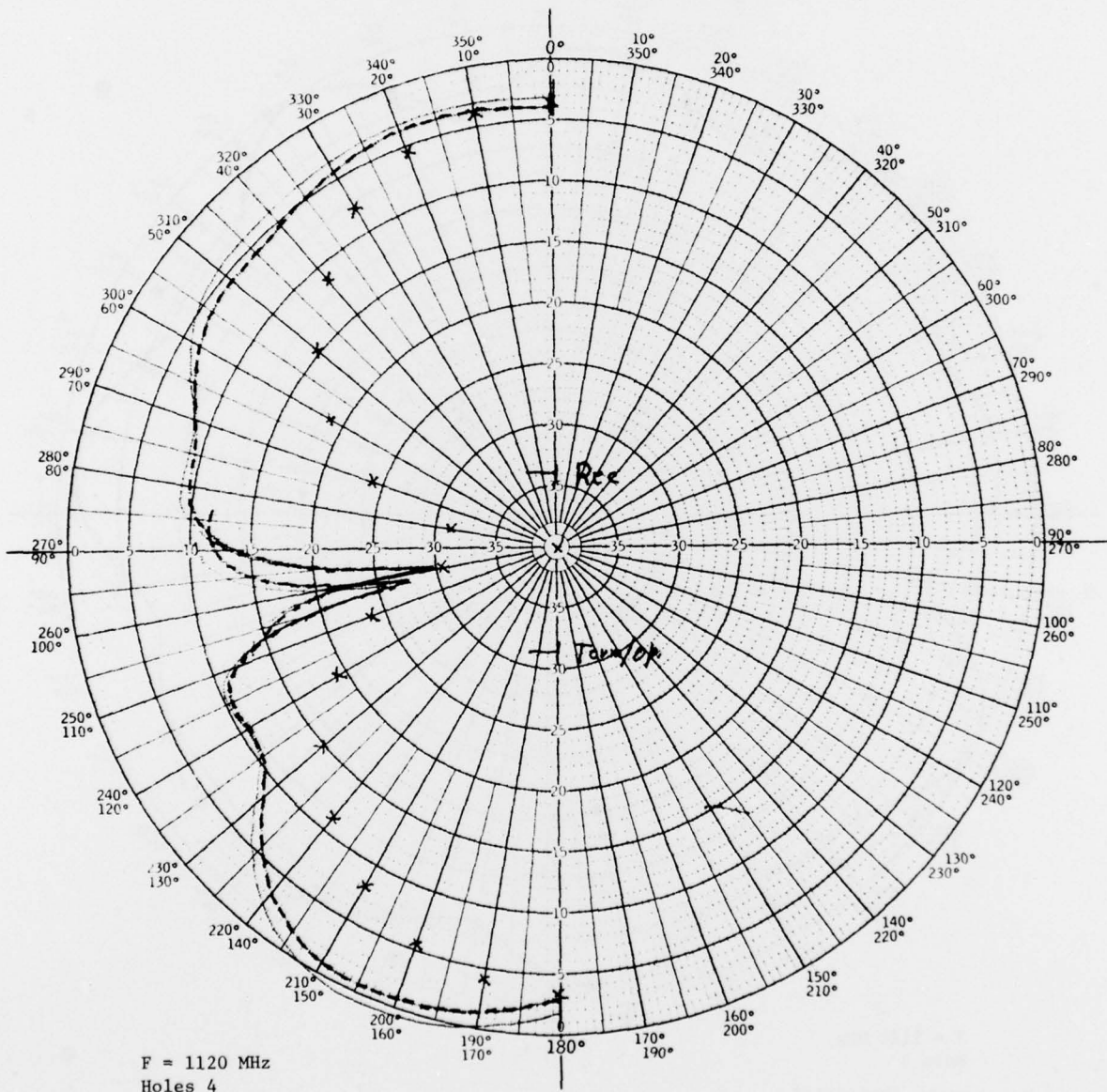

Figure 36. Four Antenna Vertical Pattern $\sim 1.25\lambda$ Spacing.

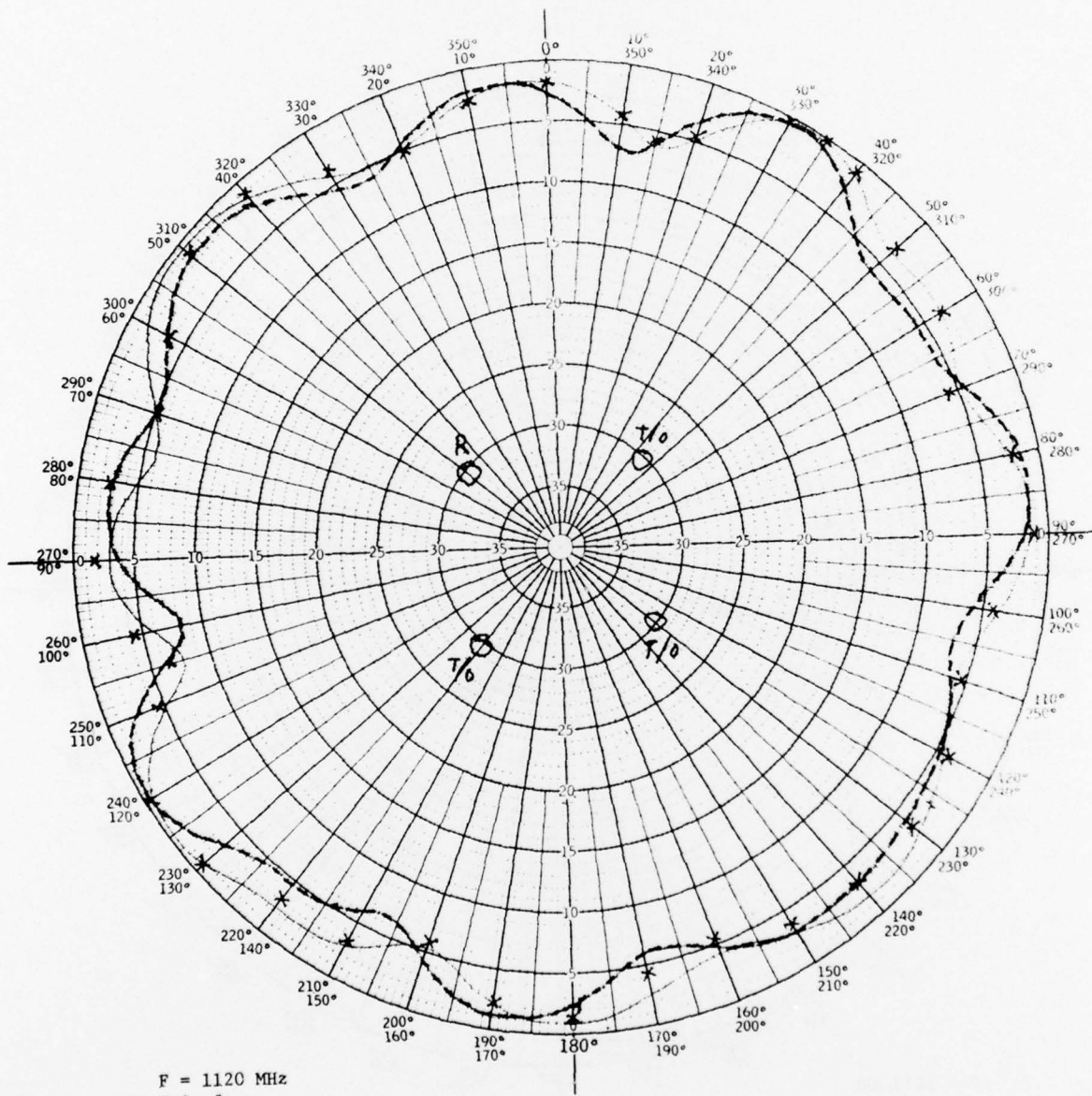

Figure 37. Four Antenna Horizontal Pattern $\sim 1.5\lambda$ Spacing.

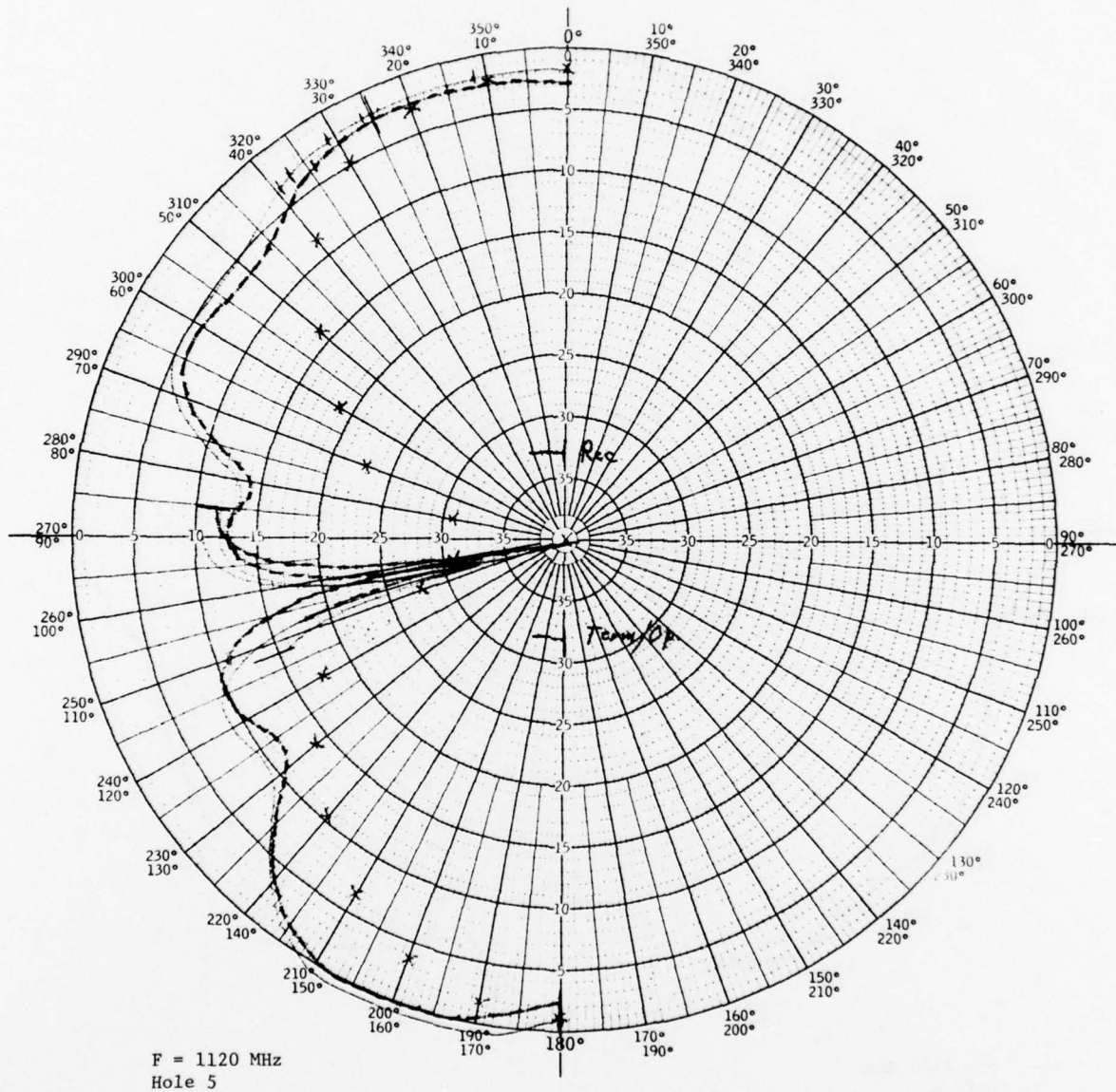

Figure 38. Four Antenna Vertical Pattern $\sim 1.5\lambda$ Spacing.

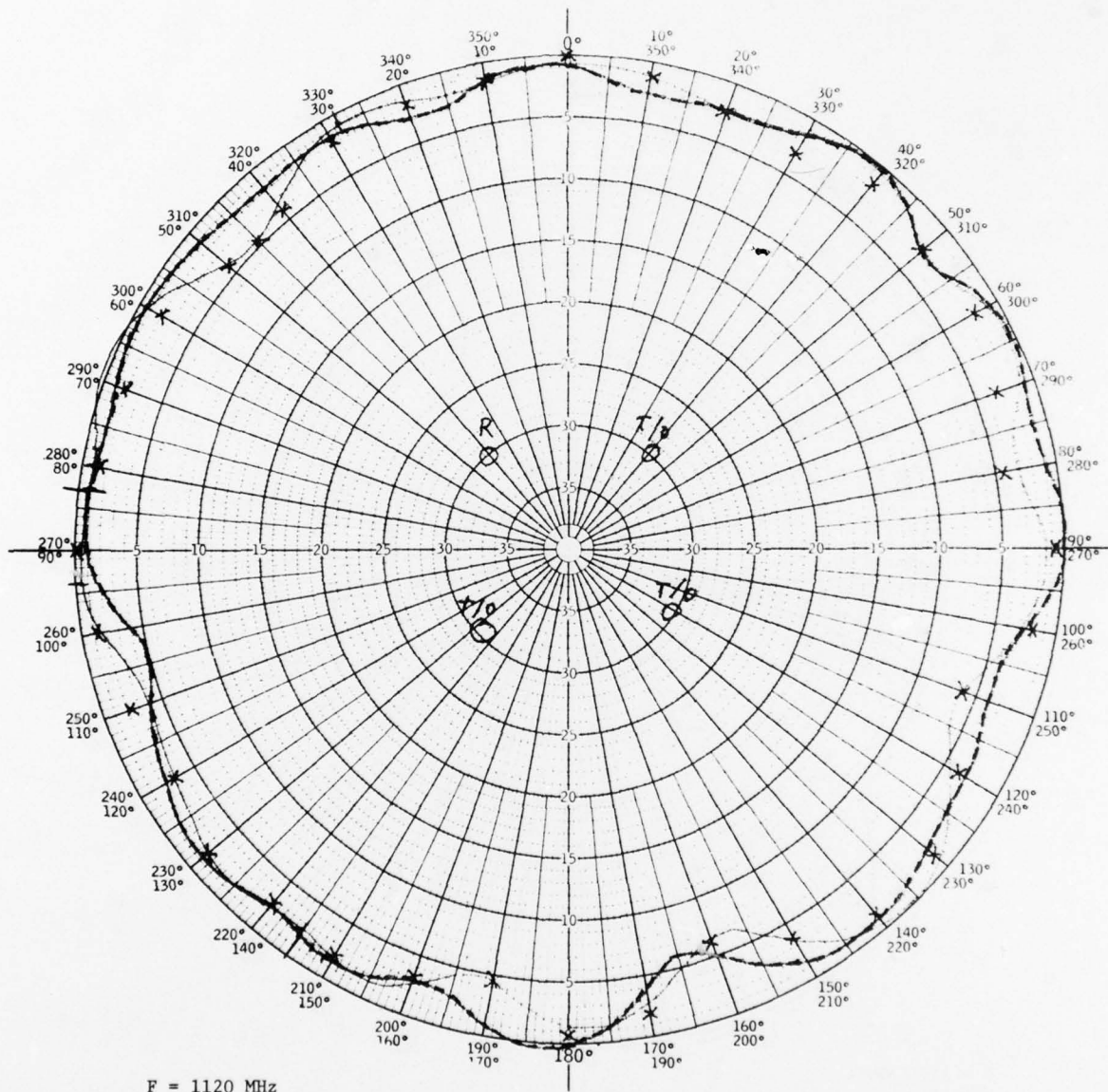
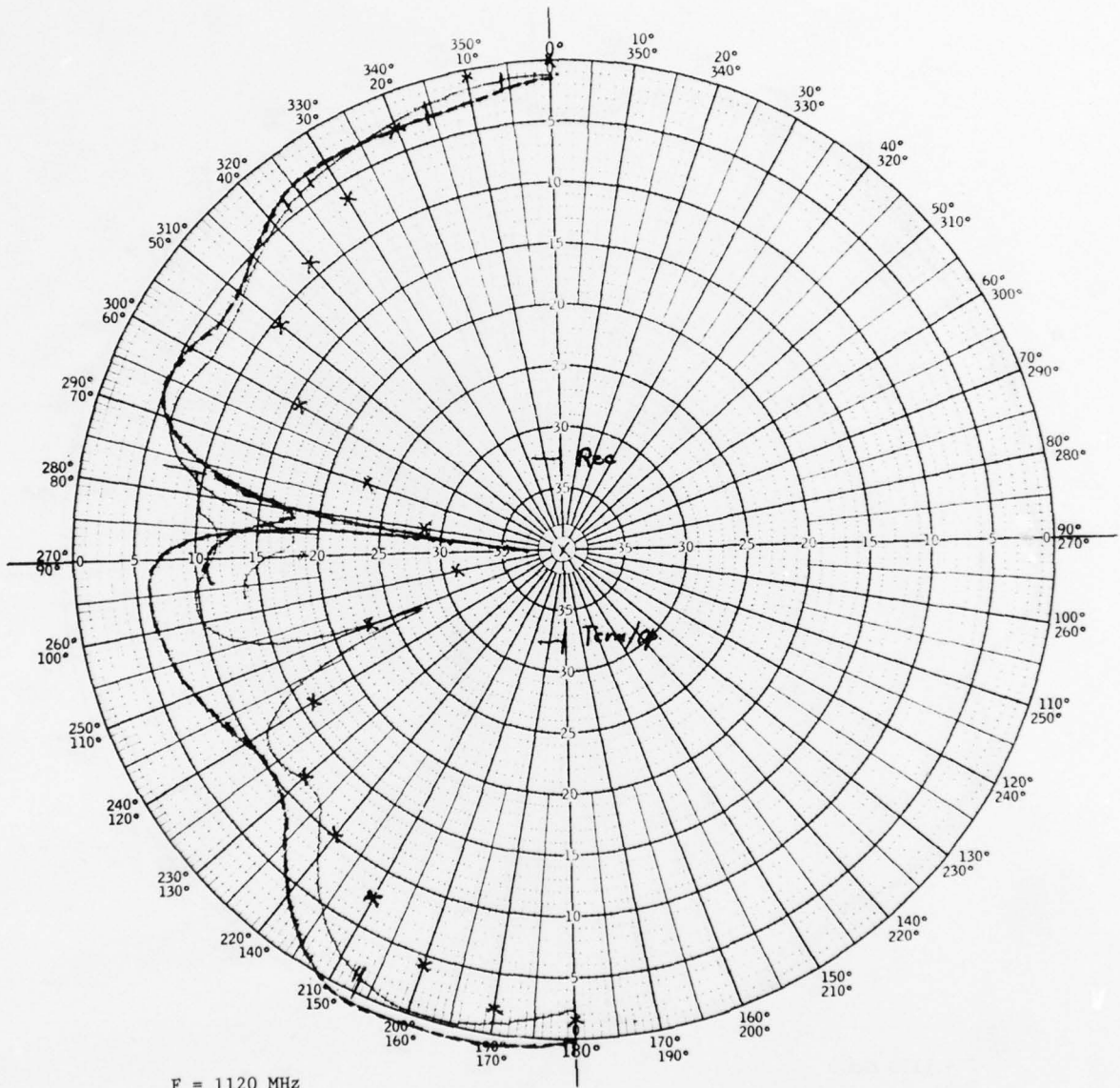

Figure 39. Four Antenna Horizontal Pattern $\sim 1.75\lambda$ Spacing.



F = 1120 MHz
Hole 6

- Terminated
- - Open
- x Computed

Figure 40. Four Antenna Vertical Pattern $\sim 1.75\lambda$ Spacing.

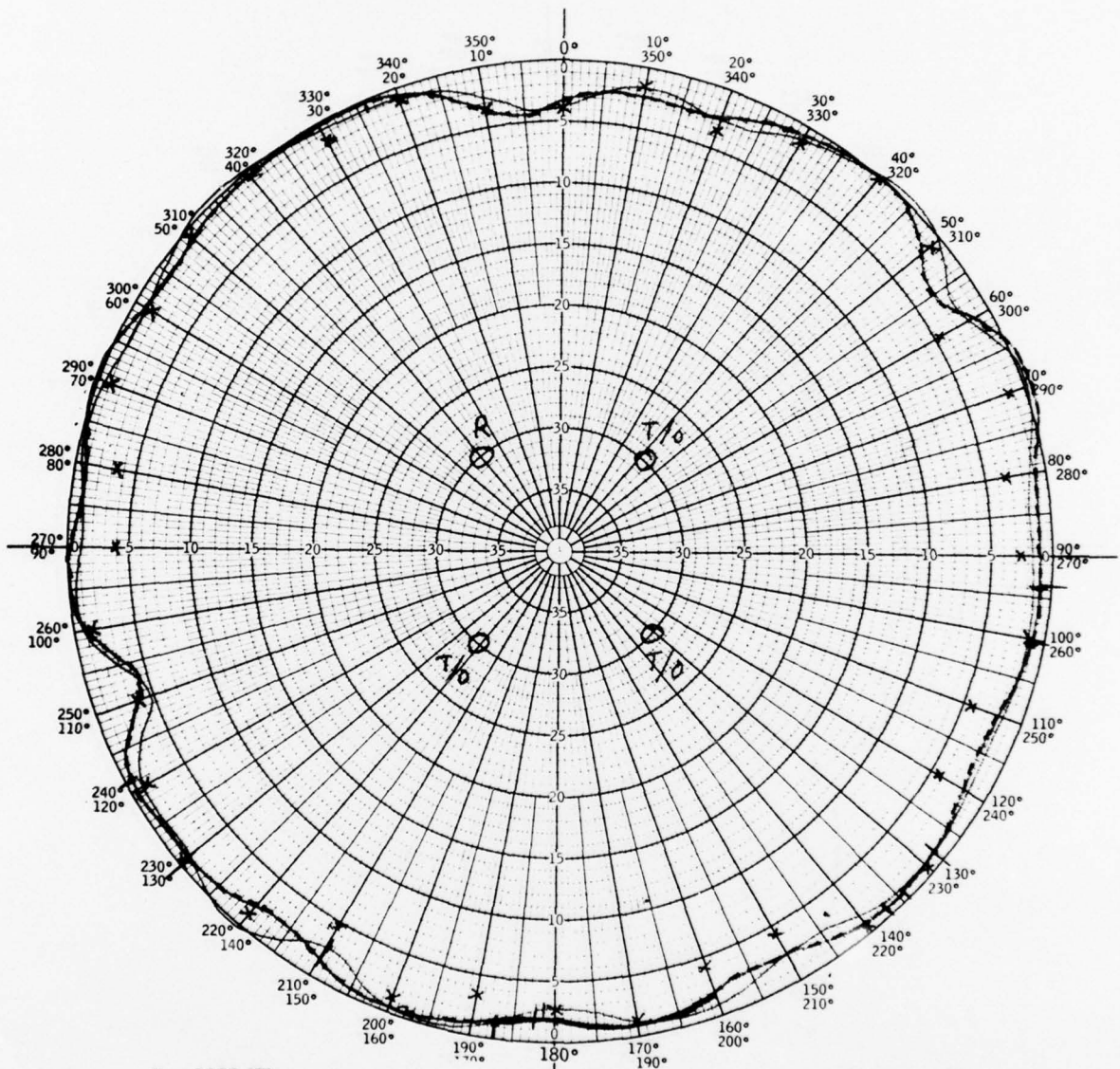

F = 1120 MHz
Hole 7

— Terminated
- - Open
x Computed

Figure 41. Four Antenna Horizontal Pattern $\sim 2.0\lambda$ Spacing.

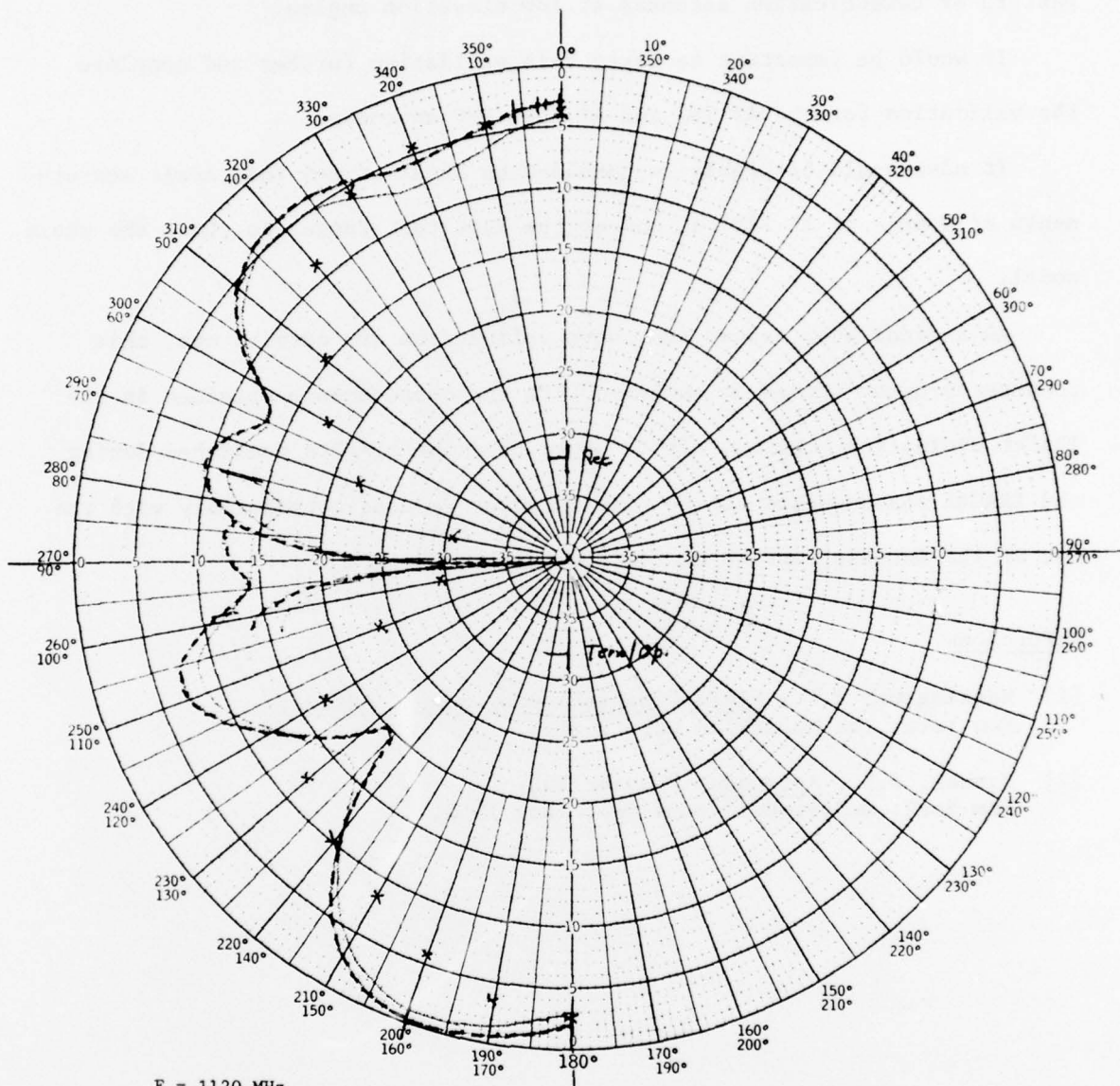

F = 1120 MHz
 Hole 7
 ——— Terminated
 - - - Open
 x Computed

Figure 42. Four Antenna Vertical Pattern $\sim 2.0\lambda$ Spacing.

6. Conclusions and Recommendations

From the results presented it is shown that the Antenna Pattern Distortion Computer Program can predict with good accuracy the radiation pattern of communication antennas at low elevation angles.

It would be important to carry this validation further and complete the validation for the AT 197 and AT 1097 UHF antennas.

It also would be highly recommended to obtain a few full scale measurements of a pair of AT 1181 at one of the RADC test ranges to check the scale model.

As a final step, after the above validations are carried out, this computer program should be compared with the measurements obtained in the TRACAL evaluation reports. It is hoped that the flights conducted during the TRACAL measurements can be eliminated or reduced considerably with the use of the Antenna Pattern Distortion Computer Program.

References

- [1] Harrington, R.F., Field Computation by Moment Methods.
New York: The Macmillan Co., 1968.
- [2] Krauss, J.D., Antennas. Chapter 15,
New York: McGraw-Hill Book Co., Inc. 1950.

