

AD-A049 792

AD



AMSAA

TECHNICAL REPORT NO. 219

VEHICLE USEFUL LIFE STUDY FOR TRUCK,
1/4 TON, 4X4, M151A1/A2

TECHNICAL
LIBRARY

RAYMOND BELL

ROBERT MIODUSKI

EDWARD BELBOT

OCTOBER 1977

APPROVED FOR PUBLIC RELEASE; DISTRIBUTION UNLIMITED.

DTIC QUALITY INSPECTED 3

U. S. ARMY MATERIEL SYSTEMS ANALYSIS ACTIVITY
ABERDEEN PROVING GROUND, MARYLAND

DISPOSITION

Destroy this report when no longer needed. Do not return it to the originator.

DISCLAIMER

The findings in this report are not to be construed as an official Department of the Army position.

WARNING

Information and data contained in this document are based on the input available at the time of preparation. The results may be subject to change and should not be construed as representing the DARCOM position unless so specified.

TRADE NAMES

The use of trade names in this report does not constitute an official endorsement or approval of the use of such commercial hardware or software. The report may not be cited for purposes of advertisement.

UNCLASSIFIED

SECURITY CLASSIFICATION OF THIS PAGE(When Data Entered)

20. Abstract (Continued)

Equipment Record Maintenance Management System (TAERS) and on the performance of 1,348 M151A1 and 385 M151A2 1/4 ton utility trucks reported in the Sample Data Collection (SDC) system. Based on the study results, it was recommended that the life of the 1/4 ton truck (in years) be extended and a mileage life be established.

UNCLASSIFIED

SECURITY CLASSIFICATION OF THIS PAGE(When Data Entered)

ACKNOWLEDGEMENT

A number of persons have significantly contributed to the completion of this study and the authors wish gratefully to acknowledge the participation of each individual. In particular, they would like to acknowledge the assistance of the Vehicle Useful Life Study Advisory Group including LTC R. Webster, DCSLOG, Chairman of the Group; LTC K. Halleran, DARCOM Study Sponsor, Mr. W. Nicols, DCSLOG; Mr. R. Meade, DARCOM; 1LT C. Moore, TACOM and Mr. E. Jackson, AMMC. The authors also wish to acknowledge the Management Information Systems of BRL, especially Messrs. Monte Coleman, Don Taylor and George Thompson for their assistance in the resolution of the programming, translating and informational storage problems associated with the use of TAERS and SDC data. Further, the assistance of the late Mr. O. P. Bruno and Dr. J. R. Johnson for their guidance in the conduct of this study and Messrs. H. Dea and R. Andrulonis of AMSAA for their assistance in the data analysis is also gratefully acknowledged.

CONTENTS

	Page
ACKNOWLEDGEMENT	3
1. EXECUTIVE SUMMARY	9
1.1 Problem	9
1.2 Approach	9
1.3 Discussion	9
1.4 Conclusions	9
1.5 Recommendations	9
2. INTRODUCTION	10
3. DATA SOURCES	10
4. VEHICLE SAMPLE	11
5. VEHICLE DESCRIPTION	12
6. USEFUL LIFE ASSESSMENT METHODOLOGY	12
7. TAERS DATA ANALYSIS	13
8. DATA PROCESSING	14
9. COST ANALYSIS	17
10. PERFORMANCE ANALYSIS	23
10.1 Unscheduled Maintenance Action Analysis	23
10.2 Inherent Readiness Analysis	25
10.3 Maintainability Analysis	28
11. PROFILE OF AN AVERAGE 1/4 TON TRUCK	34
12. COMPARISON OF TAERS AND SDC DATA	36
APPENDIX	37
REFERENCES	43
DISTRIBUTION LIST	45

LIST OF ILLUSTRATIONS

	Page
8.1 System Flowchart.	15
9.1 Instantaneous Maintenance Cost for M151A1 1/4 Ton Utility Truck	20
9.2 Cumulative Maintenance Cost for M151A1 1/4 Ton Utility Truck	22
9.3 Average System Cost for M151A1 1/4 Ton Utility Truck.	24
10.1 M151A1 1/4 Ton Utility Truck: Expected Number of Unscheduled Maintenance Actions for the Next 1000 Miles and Probability of Completing 75 Miles Without an Unscheduled Maintenance Action.	26
10.2 M151A1 1/4 Ton Utility Truck: Mean Miles Between Unscheduled Maintenance Actions (MMBUMA) and Probability of Not Undergoing Active Repair Due to an Unscheduled Maintenance Action at Any Random Point in Time (Inherent Readiness).	27
10.3 Cumulative Number of Engine Replacements for M151A1 1/4 Ton Utility Truck	32

LIST OF TABLES

	Page
4.1 Number of Vehicles Included in Study.	12
9.1 Cost Data for the M151A1 1/4 Ton Utility Truck.	18
10.1 Maintainability Data for M151A1 1/4 Ton Utility Truck . .	29
10.2 Major Component Replacements for M151A1 1/4 Ton Utility Truck	31
10.3 High Cost Part Replacements for M151A1 1/4 Ton Utility Truck	33
10.4 Ten Most Frequently Replaced Parts for M151A1 1/4 Ton Utility Truck	35
12.1 TAERS versus SDC.	36

Next page is blank.

VEHICLE USEFUL LIFE STUDY FOR TRUCK, 1/4 TON, 4X4, M151A1/A2

1. EXECUTIVE SUMMARY

1.1 Problem

To determine the age (mileage) at which it becomes economical to replace the M151A1/A2 1/4 ton truck with a new one. It is assumed that the most economical replacement point is the age at which the cost per mile is a minimum.

1.2 Approach

The useful life of the M151A1/A2 1/4 ton truck has been assessed by first establishing a cumulative average system cost as a function of mileage. An evaluation was then made of variation in RAM performance characteristics with mileage. The useful life is taken to be the age at which the cost function is minimized without significant degradation of RAM performance.

1.3 Discussion

The study was based on the performance of 8,345 M151A1 1/4 ton utility trucks reported in the Army Integrated Equipment Record Maintenance Management System (TAERS) and on the performance of 1,348 M151A1 and 385 M151A2 1/4 ton utility trucks reported in the Sample Data Collection (SDC) system. Prior to use of these performance histories, all vehicle histories were screened such that only data from vehicles with continuous consistent histories were utilized in the study. The 10,078 vehicles contained in the study had histories varying up to 72,000 miles of usage.

1.4 Conclusion

With the data limited to 72,000 miles, it is not possible to provide a meaningful estimate of the age at which the average system cost is minimized. However, the average cost is demonstrated to be decreasing over a 72,000 mile life and RAM parameters are shown to remain at acceptable levels throughout this period. It is therefore concluded that the useful life of the M151A1/A2 may be safely extended to 72,000 miles or 12 years (based on 6,000 miles per year usage).

1.5 Recommendations

It is recommended that (1) the life of the M151A1/A2 1/4 ton truck be extended from 8 to 12 years and (2) a mileage life for this truck be established at 72,000 miles.

2. INTRODUCTION

In a move by the Department of Army (DA) to reassess the useful life of the tactical wheeled vehicle fleet, the Army Materiel Systems Analysis Activity (AMSAA) was tasked by the Army Materiel Development and Readiness Command (DARCOM) Plans and Analysis Directorate to conduct a Vehicle Useful Life Study which would have the following primary objectives:

- a. Determine the age (mileage) at which it becomes economical to replace each of the four major payload tactical wheeled vehicles (1/4, 1 1/4, 2 1/2 and 5 ton vehicles).
- b. Determine the economics of overhauling wheeled vehicles and the remaining life after overhaul.

This report which is the third report pertaining to these objectives (see AMSAA TM No. 164 and TR No. 128 for the useful life determination of the 2 1/2 and 5 ton trucks, respectively) will address the determination of the useful life of the 1/4 ton truck.

3. DATA SOURCES

The data sources being utilized in this study consist of two separate Army data collection systems: (a) The Army Integrated Equipment Record Maintenance Management System (TAERS) and (b) Sample Data Collection (SDC). The TAERS data collection system for vehicles was instituted by the Army in 1963 and was designed to collect detailed maintenance information on all vehicles in the U S Army fleet. This data collection system, however, was terminated in December 1969. The SDC program for vehicles was initiated in 1972 and was also designed to collect detailed maintenance data, but only for a sample portion of the wheeled vehicle fleet. The SDC program also differs from TAERS in that the U S Army Tank-Automotive Command (TACOM) technical representatives who are in the field will monitor the data collection effort in order to insure that there is more complete reporting of data than occurred under TAERS.

In utilizing these data sources, the TAERS data can only be used to investigate vehicle replacement life for new vehicles as no appreciable quantity of data exists in TAERS for overhauled vehicles. Data on overhauled trucks are being collected in an SDC program and the economics of overhaul will be determined when sufficient data become available.

Of critical concern in the use of TAERS data for analysis purposes is the fact that many of the vehicle histories contained in the data bank are incomplete. This data omission problem is readily evident when vehicle histories are observed which show, for example, for a truck produced in late 1965 only one maintenance action reported in the time frame 1966 through 1969. As regularly scheduled maintenance actions (at least semiannually) should have occurred with this vehicle during the 1966 to 1969 interval and should have been reported (scheduled as well

as unscheduled maintenance actions are supposed to have been reported in the TAERS system), this truck obviously has incomplete data. Thus, in the use of TAERS data, it is important that incomplete periods of vehicle histories be eliminated from consideration.

The method used by AMSAA to distinguish complete from incomplete periods of vehicle histories involved the TAERS quarterly reporting system. Under TAERS, a quarterly report of any maintenance actions (scheduled or unscheduled) occurring within the quarter was required. Based on this requirement, the trucks that were selected for this study had to meet the criterion that there were at least four quarterly reports in a row (one year of continuous data) in the truck history. This criterion, although eliminating from consideration such vehicles as the one with one maintenance action in four years, as well as vehicles with only intermittent reporting, did not entirely resolve the data omission problem. Although the vehicles selected by this criterion had at least one year of continuous data, it does not necessarily imply the vehicle's entire history was complete. For example, a vehicle delivered to the Army in December 1965 may show TAERS reports in all four quarters in 1966 and the first three quarters of 1967 and subsequent to this period reports are indicated only for the third quarter of 1968 and the first and third quarter of 1969. Thus, after the third quarter of 1967 reporting became intermittent. The mileage noted on the vehicle during the first report in 1966 was 312 miles, with the mileage in the third quarter of 1967 being noted as 8,465 miles and the final mileage of 14,325 being noted by the report in the third quarter of 1969. If the missing quarters in 1968 and 1969 were ignored, this vehicle history would be assumed to be complete through 14,325 miles. However, this may not be the case as maintenance actions may have occurred in the missing quarters of 1968 and 1969. Thus, for this study, only that part of the history that provided continuous reporting was used. In the above example, only the vehicle's history from 312 to 8,465 miles would be used. The screening of the TAERS vehicle histories according to the above method, it is pointed out, treats the data, it is felt, in a conservative manner. This is noted in the above example where the vehicle history was terminated at 8,465 miles, a mileage where a known maintenance action occurred rather than estimating how many additional maintenance free miles occurred after the last maintenance action and adding this mileage or some portion of the mileage to the 8,465 miles for the history termination mileage. It should also be pointed out that this vehicle history termination technique was not necessary for all vehicles as approximately 55 percent of the vehicles included in the study had continuous histories.

4. VEHICLE SAMPLE

The principal data used in this study were obtained from TAERS reporting on 8,345 M151A1 1/4 Ton Trucks operated from 1964 through 1969. In addition, data from over 1700 M151A1 and M151A2 1/4 ton vehicles were collected in the SDC program from February 1972 to January 1975 and these

data were used to supplement the TAERS data base (see section 11 for a discussion of the use of the SDC data). A summary of the trucks obtained from the TAERS data base by theatre of operation and total accumulated mileage is shown below. It should be noted that the maximum mileage for an individual 1/4 ton truck that was used in the study was 72,000 miles.

Table 4.1 Number of Vehicles Included in Study (TAERS Data Bank)

M151A1 1/4 Ton Utility Truck

<u>Location</u>	<u>No. Vehicles</u>	<u>Total Mileage (Millions)</u>
CONUS	6,615	66.1
EUROPE	1,054	9.1
PACIFIC	676	9.0
Total	8,345	84.2

5. VEHICLE DESCRIPTION

The M151A1/A2, 1/4 ton, 4x4, utility truck is a general purpose personnel or cargo carrier. Including the driver, it provides space for four men with equipment. The truck is designed for use over all types of roads as well as cross-country terrain, and in all weather conditions. The truck has four driving wheels. Front wheel drive may be engaged as road conditions and terrain conditions require. The vehicle is powered by a four-cylinder, in-line, liquid-cooled, gasoline engine located forward of the passenger compartment under the hood. Vehicles have four-wheel hydraulic service brakes and a mechanical hand-brake operates with a contracting band on the transmission-transfer brakedrum. All wheels are individually suspended on coil springs. The body is of unitized construction and lifting eyes are provided at the wheels and pintle hooks are provided at the rear of the vehicle.

The M151A2 vehicle differs from the M151A1 vehicle in that it has an improved front and rear suspension system. Other features of the M151A2 truck are two-speed electrical wipers, manually operated washers, a one-piece windshield, a mechanical fuel pump and integrated exterior lighting at front and rear of vehicle.

6. USEFUL LIFE ASSESSMENT METHODOLOGY

The economic life of the M151A1/A2 1/4 ton truck has been assessed by determining the mileage at which the average system cost per mile (costs associated with the acquisition, shipping and maintenance of the truck) is minimized (economic life). In addition, an evaluation of the vehicle's Reliability, Availability and Maintainability (RAM) performance characteristics over the economic life span has been made to establish if the vehicle's useful life should be considered less than the

vehicle's economic life because of RAM considerations. This may be necessary, for example, if a truck at some mileage prior to the economic life mileage began having frequent breakdowns due to a relatively inexpensive part failure. This type of breakdown may not have much effect on the cost analysis but may result in a substantial degradation in the vehicle's reliability prior to the economic life mileage. If, however, the RAM parameters do not appreciably degrade throughout the economic life of the truck, then the useful life would be equal to the economic life of the truck.

7. TAERS DATA ANALYSIS

In exercising the above methodology, the procedure employed was to analyze the maintenance costs (scheduled and unscheduled) to determine how the costs were changing as the vehicle increased in mileage. This procedure was also carried out for the analysis of the RAM characteristics.

The TAERS data provided information on the maintenance actions (both scheduled and unscheduled) required for the vehicles as the vehicles increased in mileage. In particular, for each maintenance action, the following data were recorded: date action occurred, mileage at which action occurred, maintenance level (organization or support), man-hours required, failure detection code (i.e., whether the action was detected in normal operation of the vehicle, during an inspection or during a regularly scheduled maintenance action), remedial action taken (repaired, replaced, adjusted or is simply the result of normal services), part name and Federal Stock Number, and quantity of parts replaced.

The analysis of the data from a cost standpoint utilized the parts' costs contained in the Army Master Data File. The cost information is in 1975 dollars and was supplied to AMSAA by the US Army DARCOM Catalog Data Activity. The mean labor rate used in this study was \$6.02 an hour. It is noted that there were approximately 230,000 maintenance actions for the 8,345 vehicle sample and about half of these were parts replacements. As noted earlier in this report, data omission presented a serious problem in the analysis of TAERS data. As a result of this problem, many vehicle histories were incomplete. For example, the vehicle discussed earlier was considered to have a complete history only from 312 to 8465 miles. Other vehicles had histories beginning and ending at various different mileages. In the costing of the maintenance actions by mileage, it was thus necessary to be aware of each vehicle's mileage interval. The costing procedure involved determining the total cost (parts and labor) experienced by the vehicles for each 100 mile interval. In this compilation, the vehicle with a history of 312 to 8465 miles contributed only to the cost total beginning with the 300 to 400 mile interval and ending with the 8400 to 8500 mile interval. Thus, the sample size for each 100 mile interval varied. This procedure, as mentioned earlier, probably conservatively estimates the costs sustained since the vehicle which is noted to have its last maintenance action at 8,465 miles probably traveled some additional miles without having to sustain any

additional maintenance actions but in the procedure employed the vehicle was considered to contribute to the cost input up to 8500 miles only.

The analysis of the TAERS data from a RAM standpoint presented an additional problem. Normally in the analysis of data for the determination of reliability and availability estimates, failure data is required. However, from the TAERS data it is extremely difficult, if not impossible, to determine for all unscheduled maintenance actions which actions are reliability failures. As a result of this fact, an analysis of all unscheduled maintenance actions was undertaken rather than the usual analysis of failures. Specifically, the analysis consisted of three phases, all with the objective of determining how the vehicle's performance was changing as the vehicle increased in mileage: (1) unscheduled maintenance action analysis - the goal of this analysis was to determine the probability of completing 75 miles without an unscheduled maintenance action (UMA) for continually increasing mileages, (2) inherent readiness analysis - the goal of this analysis was to determine as a function of mileage, the probability that the vehicle is not undergoing active repair due to an unscheduled maintenance action when required for use at a random point in time, and (3) maintainability analysis - this analysis consisted of determining, as a function of mileage, the maintenance support index (MSI), the average man-hours required per vehicle per 1000 miles of usage, and the average man-hours required per maintenance action.

8. DATA PROCESSING

The large volume of data involved in this study (over 1,060,000 lines of data) required substantial electronic data processing. All data processing was conducted at Aberdeen Proving Ground using the Ballistic Research Laboratories Electronic Scientific computers (BRLESC I and II) and the UNIVAC 1108 computer. The programs utilized in the study were written in FORTRAN, FORAST, OMNITAB II, and BRLESC Assembly Language. The flowchart shown on Figure 8.1 represents the major programs, the input and output relations, the large printouts generated, and the manual operations directly related to the automated processing in the study. It should be mentioned here that it is the intention of the authors to provide the reader with an overall view of the computer programming effort required for this study. The details of the computer programs are documented in BELBOT (1975).

The TAERS data utilized in this study were received from the U S Army Maintenance Management Center (AMMC) on magnetic computer tape in IBM bit code. The 18 data tapes received had to be translated to BRLESC bit code and reformatted to TAERS format after translation. Each of the tapes were then decoded into a more readable, columnarized, and labelled form written on output tapes from which a paper copy was printed. These decoded tapes were then screened for errors.

The screening and correction of the basic data involved nine programs. The lines of each vehicle history were placed in order of

FIGURE 8.1 (CONT'D)

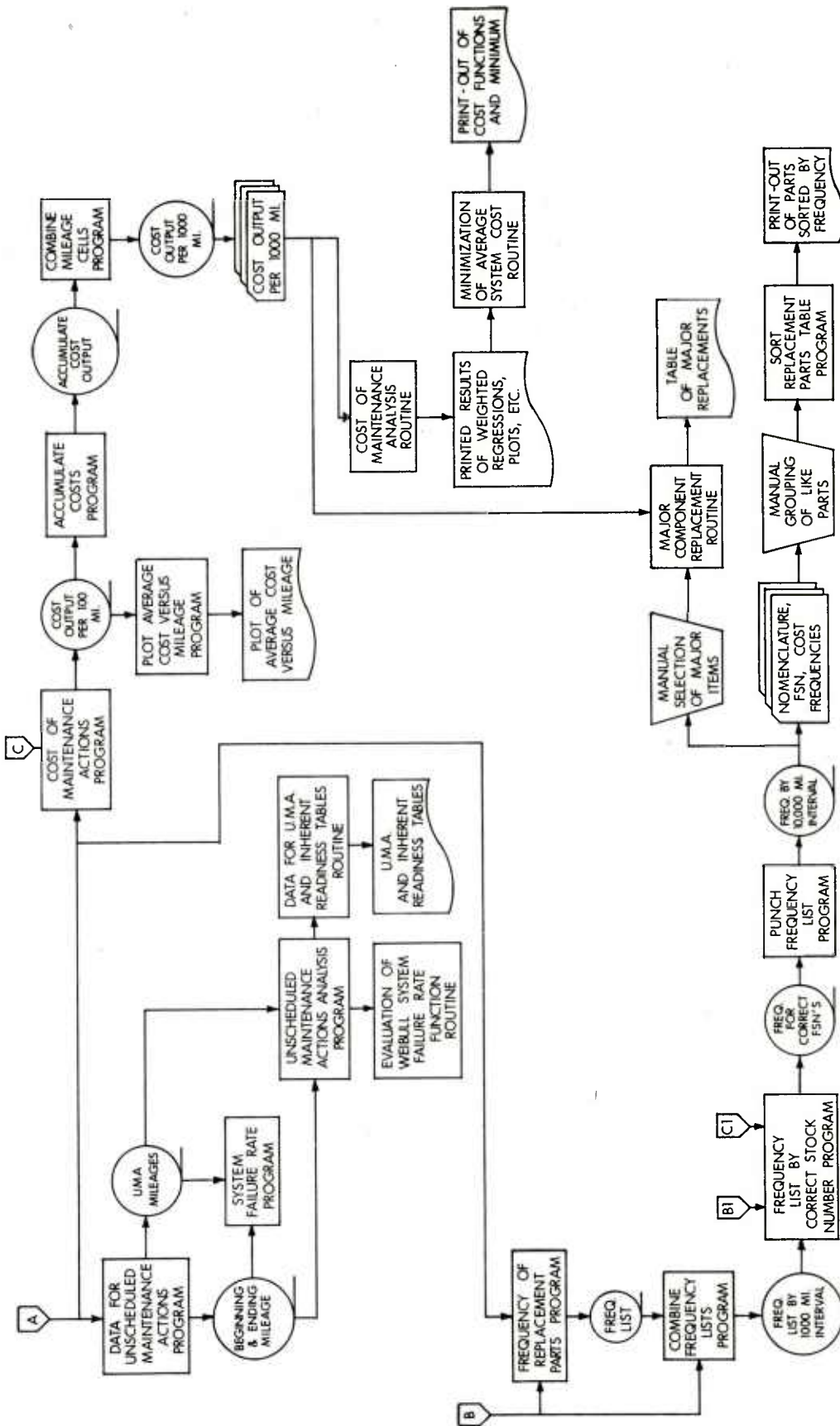

date and the mileage sequences were checked. A history with a single mileage discrepancy was corrected by replacing the mileage entry in question by the mean of the prior and subsequent mileage entries. Two or more mileage discrepancies caused the vehicle under examination to be deleted from further consideration in the study. The data were subsequently screened for large gaps between reporting dates (missing quarters) and only that portion of each history free of intermittent reporting was accepted for use. The proper functioning of this phase of the correction process was then verified by a separate computer program. The quantities of parts replaced were checked and vehicle histories with errors were marked for deletion. Additionally, the vehicle histories were manually examined for those infrequently occurring errors which are not readily detected by computer. A list of vehicles with errors was prepared, and these histories were removed from the data tapes.

From each tape, a list of replacement parts with distinct FSN's was accumulated, sorted, and placed in a separate tape file. The resulting files were then merged to form a combined parts list. To obtain part costs and correct nomenclature, TACOM was provided with three distinct listings of the parts, sorted by FSN, sorted by FIIN (last seven digits of the FSN), and sorted alphabetically. The parts list was also used to search the Army Master Data File (AMDF) for cost and nomenclature information.

The processing of the data included the determination of the following: the usage rate of each vehicle; the mileage interval covered by each vehicle; the average number of, and man-hours expended for each maintenance action; the rate of unscheduled maintenance actions; the total frequency of each part replaced; the identification of vehicles requiring replacement of major components, and the cost of maintenance by 100 mile intervals. Additionally, a weighted polynomial regression curve fitting procedure was applied to the cost data, and the minimum value of average system cost function was determined.

The automated portion of this study required the usage of over 200 reels of magnetic tape and of approximately 15,000 computer punch cards, and resulted in the generation of over 25 linear feet of computer printout.

9. COST ANALYSIS

As noted earlier, the object of the cost analysis was to determine how the maintenance costs were varying as the truck mileage was increasing in order that the average system cost could be minimized. Thus, all the maintenance actions occurring with the 8,345 trucks in the study were costed in constant FY 75 dollars (parts and labor) as a function of mileage. See Table 9.1 for a summary of the costs as a function of mileage (in 1000 mile intervals) for mileages from 0 to 72,000 miles.

TABLE 9.1 COST DATA FOR THE M151A1 1/4 TON UTILITY TRUCK

MILEAGE INTERVAL (1000's)	AVERAGE NO. OF TRUCKS	NO. OF MAINT. ACTIONS (SCH. & UNSCH.)	NO. OF MAN-HRS	TOTAL LABOR COST (\$)	PARTS COST (\$)			TOTAL COST (\$)	MILEAGE INTERVAL (1000's)	AVERAGE NO. OF TRUCKS	NO. OF MAINT. ACTIONS (SCH. & UNSCH.)	NO. OF MAN-HRS	LABOR COST (\$)	PARTS COST (\$)			TOTAL COST (\$)
					ALL PARTS EXCEPT ENGINE	ENGINE	TOTAL							ALL PARTS EXCEPT ENGINE	ENGINE	TOTAL	
0-1	3346	16252	39335	236796	79444	3304	82748	319544	35-37	441	1096	1952	11754	11369	3604	14973	26727
1-2	3785	9670	18668	112378	81072	4355	85427	197805	37-38	409	1030	2119	12755	10656	1802	12458	25213
2-3	4012	10571	21611	130098	79095	4055	83150	213248	38-39	366	910	1723	10375	10162	5257	15419	25794
3-4	4159	12124	26454	159255	82175	4955	87130	246385	39-40	334	970	1799	10831	9573	5106	14679	25510
4-5	4154	10707	19684	118496	85646	8410	94056	212552	40-41	284	622	1271	7650	5037	3604	8641	16291
5-6	4093	10620	19910	119859	85255	5857	91112	210971	41-42	260	574	1188	7155	7273	3304	10577	17732
6-7	4015	11836	24263	146063	85355	5106	90461	236524	42-43	232	624	1197	7208	7111	2853	9964	17172
7-8	3864	9601	17557	105691	79338	5106	84444	190135	43-44	204	446	805	4847	4650	1802	6452	11299
8-9	3697	9281	17488	105279	74334	7659	81993	187272	44-45	185	448	846	5095	5800	2102	7902	12997
9-10	3542	9714	18939	114013	78549	11112	89661	203674	45-46	167	371	798	4801	3481	4355	7836	12637
10-11	3374	9300	17528	105516	76231	8859	85090	190606	46-47	148	379	779	4688	2783	2853	5636	10324
11-12	3185	8006	14961	90066	73779	7508	81287	171353	47-48	136	303	460	2771	2723	1051	3774	6545
12-13	2986	8441	16890	101677	69015	18622	87637	189314	48-49	122	317	658	3959	2893	6306	9199	13158
13-14	2829	6955	12743	76712	62761	10061	72822	149544	49-50	110	250	560	3369	2038	1051	3089	6458
14-15	2660	6764	12769	76869	59608	6457	66065	142934	50-51	103	228	429	2581	2974	1051	4025	6606
15-16	2481	6619	12947	77940	59182	8710	67892	145832	51-52	91	268	559	3363	2420	2253	4673	8036
16-17	2311	5787	11315	68116	55712	6157	61869	129985	52-53	84	163	448	2695	1083	1051	2134	4829
17-18	2158	4969	9497	57173	46693	4955	51648	108821	53-54	75	146	322	1940	1205	0	1205	3145
18-19	2011	5583	11022	66355	49416	8559	57975	124330	54-55	66	133	242	1456	1128	2553	3681	5137
19-20	1860	4756	8795	52945	42006	12914	54920	107865	55-56	55	130	249	1501	945	1051	1996	3497
20-21	1732	4225	8418	50675	40961	8710	49671	100346	56-57	50	98	176	1057	692	751	1443	2500
21-22	1577	4176	8472	51003	37121	7808	44929	98931	57-58	43	95	229	1380	625	1051	1676	3056
22-23	1456	3779	6874	41383	39087	7359	46446	87829	58-59	37	95	155	933	1063	0	1063	1996
23-24	1352	3780	6860	41300	36168	6757	42925	84225	59-60	36	98	238	1433	943	0	943	2376
24-25	1248	3148	5936	35737	29330	7508	36838	72575	60-61	31	79	164	985	516	0	516	1501
25-26	1145	2906	5571	33535	29841	7959	37800	71335	61-62	30	83	148	891	535	0	535	1426
26-27	1041	2750	5499	33105	25035	5406	30441	63546	62-63	25	79	164	987	654	0	654	1641
27-28	957	2314	4461	26855	19345	5706	25051	51906	63-64	23	95	155	931	901	0	901	1832
28-29	905	2364	4433	26685	28831	5406	31237	57922	64-65	21	119	156	941	799	0	799	1740
29-30	845	2107	3695	22243	17685	4655	22340	44583	65-66	18	57	82	496	599	0	599	1095
30-31	792	1841	3899	23472	19994	5857	25851	49323	66-67	15	56	72	433	395	0	395	828
31-32	737	1828	3676	22133	19331	9761	29092	51225	67-68	12	61	90	539	522	1051	1573	2112
32-33	665	1561	3094	18623	14942	3304	18246	36869	68-69	10	43	44	265	251	0	251	516
33-34	589	1507	2891	17406	14906	5706	17908	35314	69-70	11	27	33	199	162	0	162	361
34-35	532	1300	2724	16398	12632	2553	15185	31583	70-71	11	45	39	594	419	0	419	1013
35-36	482	1036	1930	11616	11314	1051	12365	23981	71-72	10	38	70	421	347	0	347	771

The methodology employed in the analysis of these data involved the determination of a continuous instantaneous maintenance cost curve (the instantaneous maintenance cost refers to the maintenance cost per mile at a particular mileage). This curve was used to obtain the cumulative maintenance cost curve and an average system cost curve (the system cost refers to all those costs associated with the procurement, shipment and maintenance of a vehicle including such costs as the vehicle's acquisition price, administrative expenses sustained, tooling costs, first and second destination charges, and maintenance costs). From the average system cost curve, the mileage at which the average system cost is at a minimum can be determined, which represents the point where the overall average cost to the Army to procure, ship, and maintain the vehicle fleet is at a minimum.

In determining the continuous maintenance cost curve, it was necessary to conduct two separate cost analyses. This was due to the increasing rate of engine replacements as the vehicle mileage increased and to their high costs relative to the other maintenance action costs. Consequently, a continuous instantaneous maintenance cost curve was determined for all maintenance actions excluding engine replacements and a similar cost curve for engine replacement actions only was also determined. From these two curves, the continuous instantaneous maintenance cost curve was generated.

In the analysis of the average maintenance cost data excluding engine replacement costs, weighted regression analysis techniques were applied. No significant regression fit was found to represent the data as a function of the independent variable (mileage) beginning at 1000 miles and therefore the cost function was considered a constant for the mileage interval 1000 through 72,000 miles. The constant determined was .053 dollars per mile (See Figure 9.1). The average maintenance cost data for the 0-1000 mile interval were subsequently considered in determining the constant for the cumulative maintenance cost curve.

In the analysis of the engine replacement actions, a weighted regression analysis of the engine replacement rates determined that a quadratic function was found best to represent the data. Utilizing an average engine cost of \$901, the following instantaneous engine replacement cost curve was obtained:

$$f(x) = .0012 + .000070 x + .0000047 x^2$$

where

$$f(x) = \text{instantaneous engine replacement cost (dollars per mile)}$$
$$x = \text{mileage (1000's)}$$

Utilizing the above function and the constant cost (\$.053/mile), the following instantaneous maintenance cost curve (See Figure 9.1) was determined:

FIGURE 9.1

INSTANTANEOUS MAINTENANCE COST FOR
M151A1 1/4 TON UTILITY TRUCK

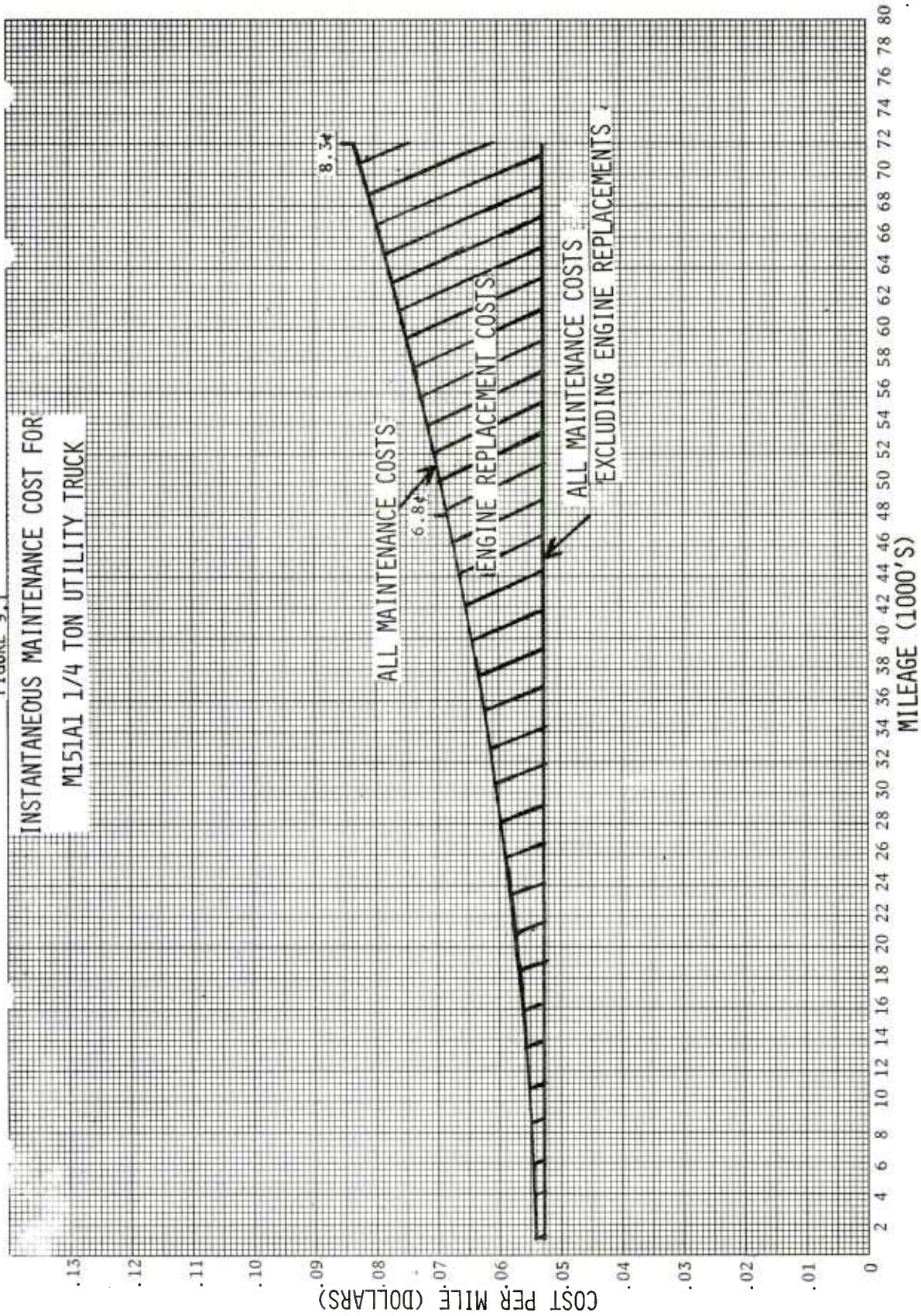

$$f(x) = .054 + .000070 x + .0000047 x^2$$

where

$f(x)$ = instantaneous maintenance cost (dollars per mile)

x = mileage (1000's) ≥ 1

From the continuous instantaneous maintenance cost curve, the cumulative cost curve was obtained. However, as previously noted, the average maintenance cost excluding engine replacement costs for the 0-1000 mile interval was considered in determining the constant for this function. The function determined (See Figure 9.2) was:

$$F(x) = 41.72 + 54.01 x + .0350 x^2 + .00158 x^3$$

where

$F(x)$ = cumulative maintenance cost (FY 75 dollars)

x = mileage (1000's) ≥ 1

The results of the above analyses revealed the following:

1. The instantaneous maintenance cost (the maintenance cost per mile at a specific mileage) when excluding engine costs was found not to change (5.3¢ per mile) as the vehicle accumulated 72,000 miles.

2. The instantaneous maintenance cost attributed to engine replacement costs was found to be increasing with increasing vehicle usage. For example, the instantaneous maintenance cost attributed to engine replacements was found to be increasing from 0.2¢ per mile at 1000 miles to 3.0¢ per mile at 72,000 miles. It should be noted that the engine costs presented are based on replacing the engine with a new engine whereas it is known that part of the time the engine is replaced with an overhauled engine which may be less costly than a new engine. This was done in order to provide a conservative or worst case cost portrayal.

3. The overall instantaneous maintenance costs associated with all parts including the engine was thus also found to be increasing with increasing vehicle usage. For example, the average cost per truck was found to be increasing from 5.5¢ per mile at 1,000 miles to 8.3¢ per mile at 72,000 miles.

4. From a cumulative cost standpoint (See Figure 9.2), it is shown that the average 1/4 ton truck will sustain a maintenance cost of \$4,700 over 72,000 miles of usage.

FIGURE 9.2
 CUMULATIVE MAINTENANCE COST FOR
 MISIAL 1/4 TON UTILITY TRUCK

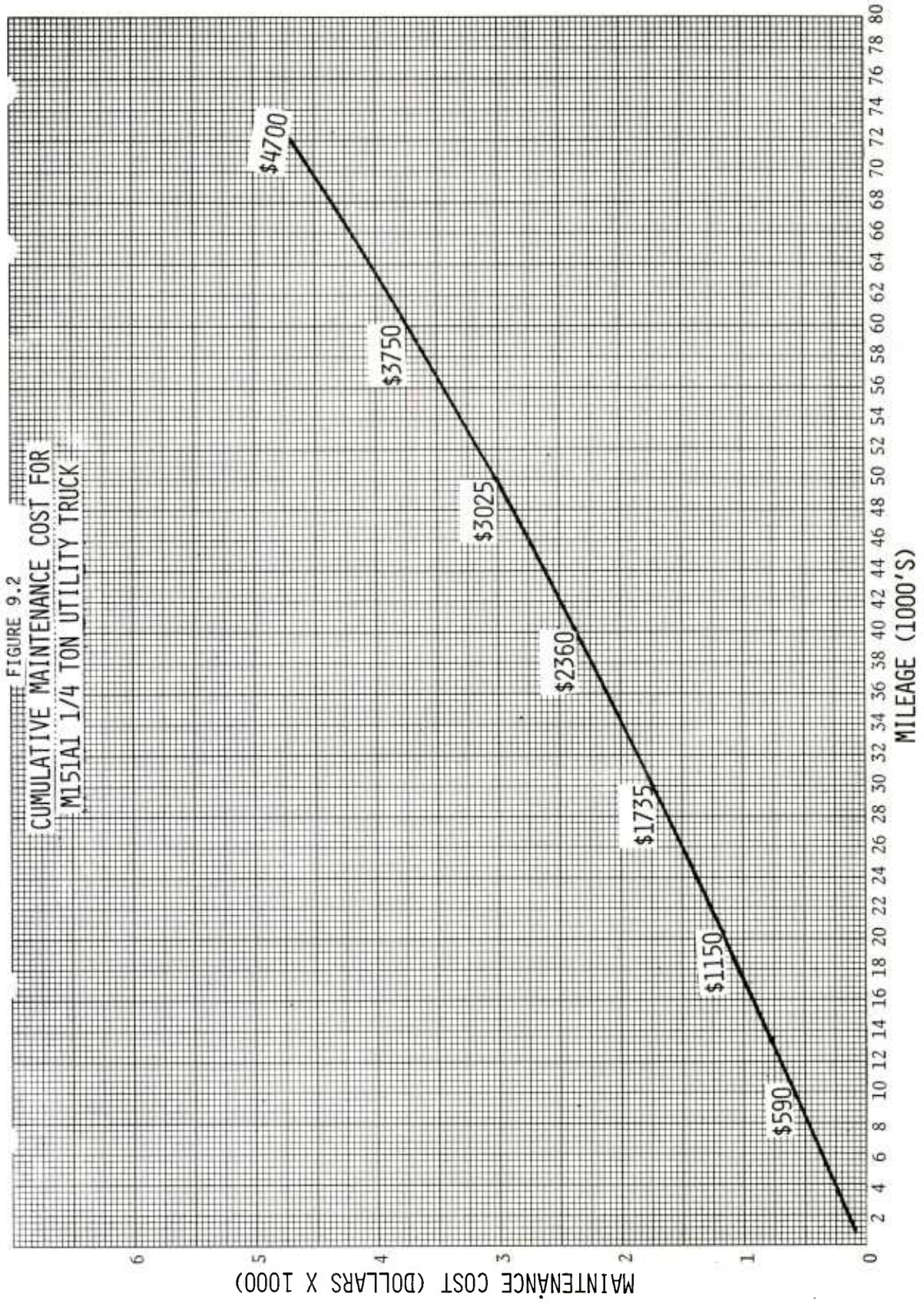

As stated earlier, the primary objective of this cost analysis was to determine the mileage at which the overall system cost to the Army is at a minimum; i.e., the costs associated with procuring, shipping, and maintaining the truck are minimized. Utilizing the cumulative maintenance cost curve developed and the truck rollaway cost (includes acquisition costs, engineering and tooling costs, administrative costs, first destination charge and applicable second destination charge) of \$6,500, an average system cost as a function of mileage was determined. A plot of the average system cost as a function of mileage is shown on Figure 9.3. As noted on this figure, the minimum of the average system cost is indicated to be beyond 72,000 miles although at this mileage the average system cost is found to be near its minimum. For example, at 72,000 miles, the average system cost is noted to be decreasing by less than 0.5¢ per mile for each additional 1000 miles of usage (through an extrapolated 80,000 miles of usage). Based on these results, the economic life of these trucks was considered to be 72,000 miles (See Appendix for assumptions related to the economic replacement policy).

10. PERFORMANCE ANALYSIS

10.1 Unscheduled Maintenance Action Analysis

As indicated earlier, in place of a reliability failure analysis, an analysis of all unscheduled maintenance actions was carried out due to the difficulty in determining if an unscheduled maintenance action was in fact a reliability failure. In analyzing the unscheduled maintenance actions, utilizing weighted regression techniques, a quadratic function was found to represent best the system unscheduled maintenance action rate as a function of vehicle mileage. The rate function determined was:

$$r(x) = 0.953 - .0115 x + .000108 x^2$$

where

$$x = \text{mileage (1000's)}$$

Since it is assumed that this system is a repairable system, the probability that a vehicle will have an unscheduled maintenance action at mileage x is independent of the unscheduled maintenance action history of the vehicle prior to x .

From this function, the probability that a vehicle with mileage x will complete an additional s miles without undergoing an unscheduled maintenance action (as determined by a non-homogeneous Poisson process) is,

$$P(s/x) = e^{-\int_0^{x+s} r(x)dx} + \int_0^x r(x)dx$$

where $\int_0^{x+s} r(x)dx - \int_0^x r(x)dx$ is the expected number of unscheduled maintenance actions for a vehicle during the mileage interval $(x, x+s)$.

FIGURE 9.3

AVERAGE SYSTEM COST FOR
MILITARY 1/4 TON UTILITY TRUCK

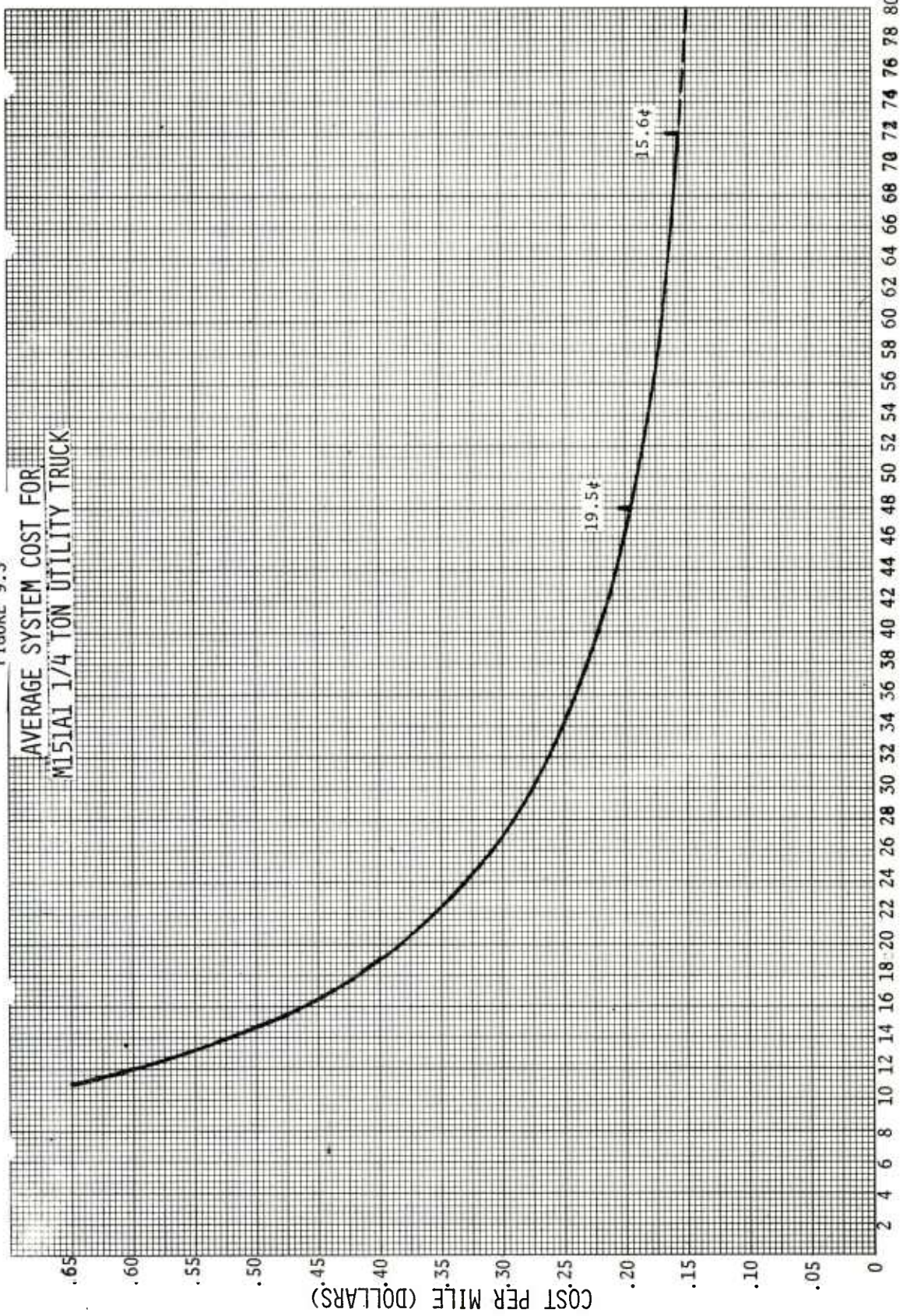

The results of this analysis are on Figure 10.1. Indicated are the expected number of unscheduled maintenance actions for the next 1000 miles and the probability of completing 75 miles without an unscheduled maintenance action from 0 to 72,000 miles. As can be readily observed from this figure, there is no appreciable change in these parameters as the vehicle is increasing in mileage through 72,000 miles. The average probability of completing 75 miles without requiring an unscheduled maintenance action over the 0-72,000 mile interval is .95.

10.2 Inherent Readiness Analysis

As with a reliability analysis, the determination of availability is normally based on failure data. For example, Inherent Availability (A_i) is normally defined as:

$$A_i = \frac{MTBF}{MTBF + MTTR}$$

where MTBF is the mean time between failures and MTTR is the mean time to repair.

As noted in previous sections of this report, unscheduled maintenance actions rather than failure data were available. Further, the TAERS data provided information on the mean man-hours to repair rather than the mean time to repair. The mean time to repair for a particular maintenance action could be less than the man-hours involved if two or more mechanics worked on the action. To utilize these data, however, to obtain an estimate of an availability statistic, one can determine the probability of a truck not undergoing active repair due to any unscheduled maintenance action when called upon to operate at a random point in time (Inherent Readiness) and this is given by the following expression:

$$R_i = \frac{MTBUMA}{MTBUMA + MMHTR}$$

where MTBUMA is the mean time between unscheduled maintenance actions (assuming an average speed of 20 mph) and MMHTR is the mean man-hours to repair. It should be noted that the Inherent Readiness parameter is a lower bound on an Inherent Availability value, i.e., if all unscheduled maintenance actions were reliability failures and if no more than one mechanic ever worked on a maintenance action then the mean man-hours to repair would be equivalent to the mean time to repair and $R_i = A_i$.

The results of this analysis are shown on Figure 10.2. Indicated on this figure are the mean miles between unscheduled maintenance actions (MMBUMA) and Inherent Readiness (R_i) values for M151A1 1/4 ton trucks through 72,000 miles of usage. As can be readily observed on this figure, no appreciable degradation in the R_i value has occurred as the

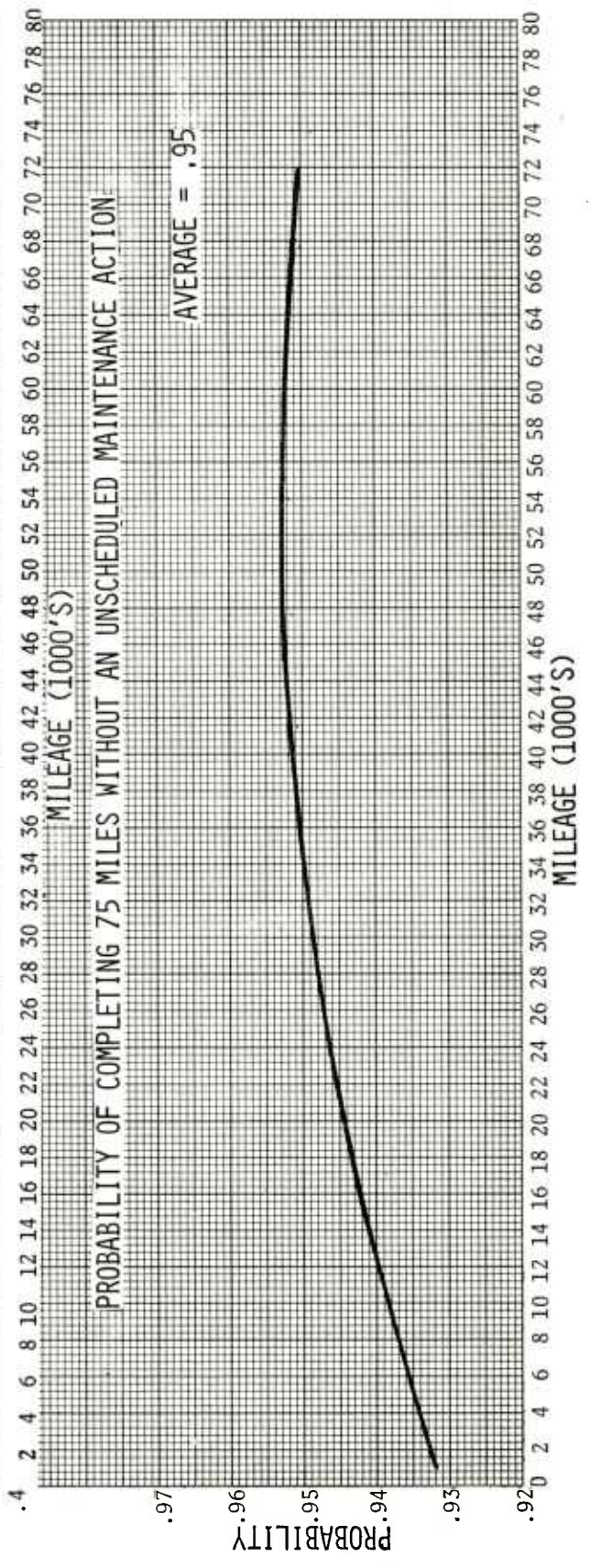
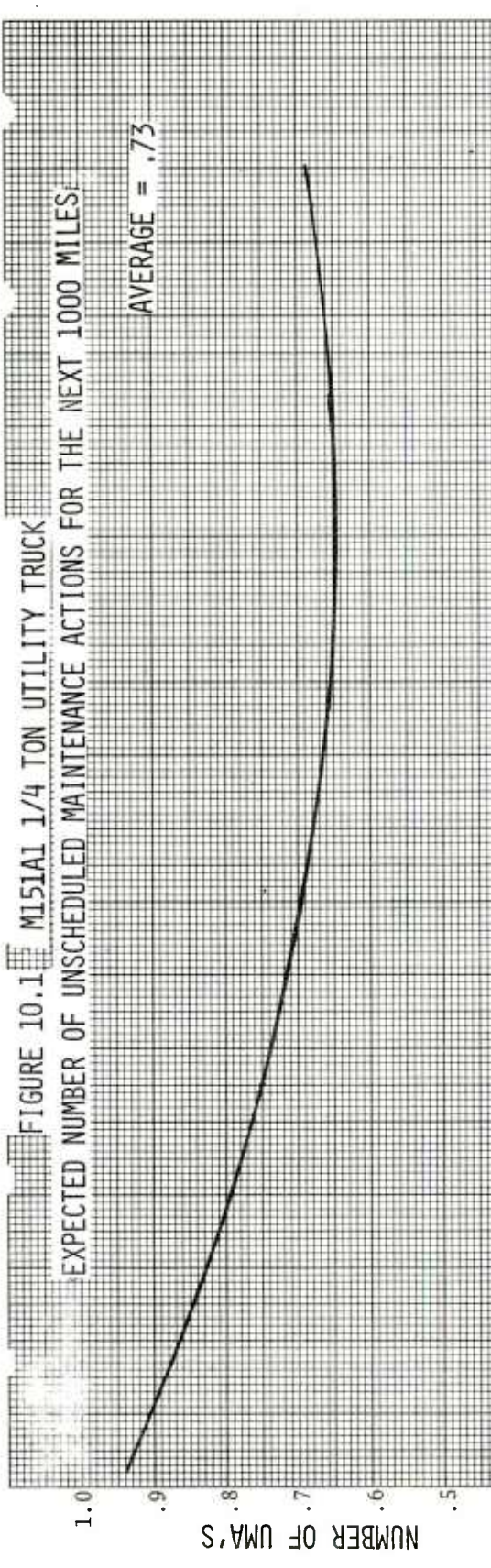

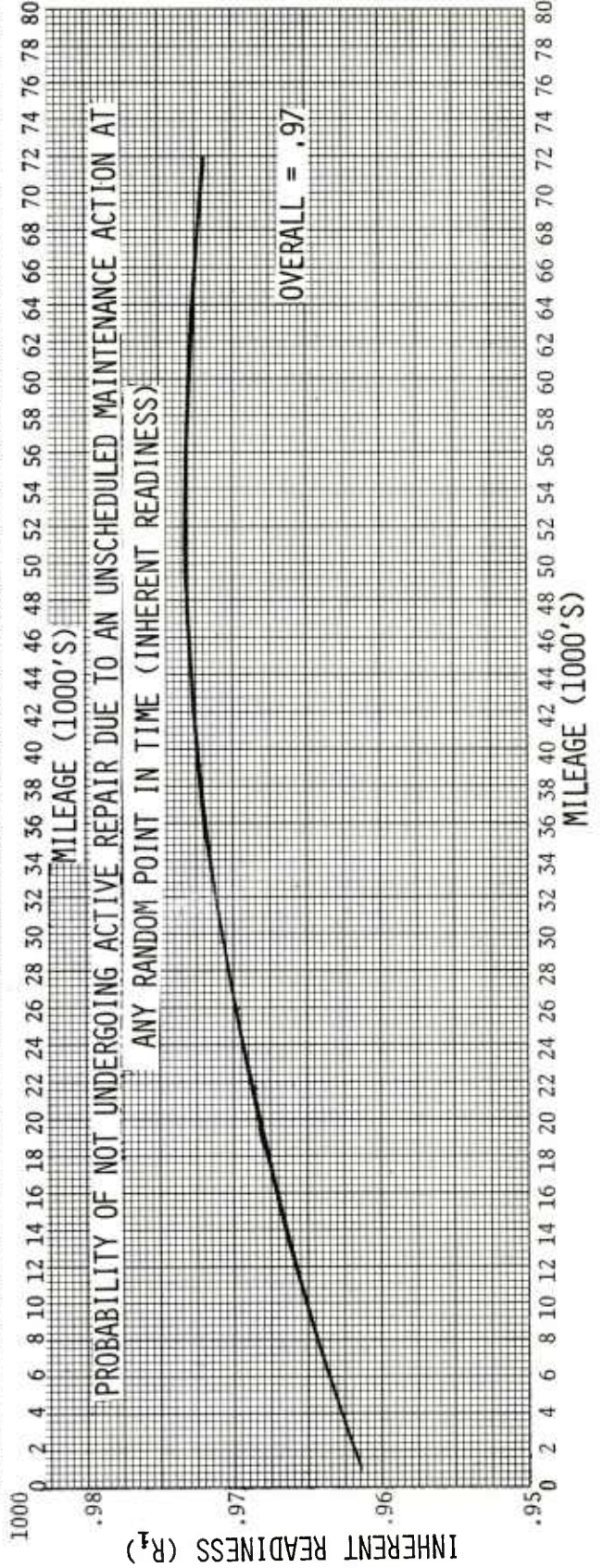
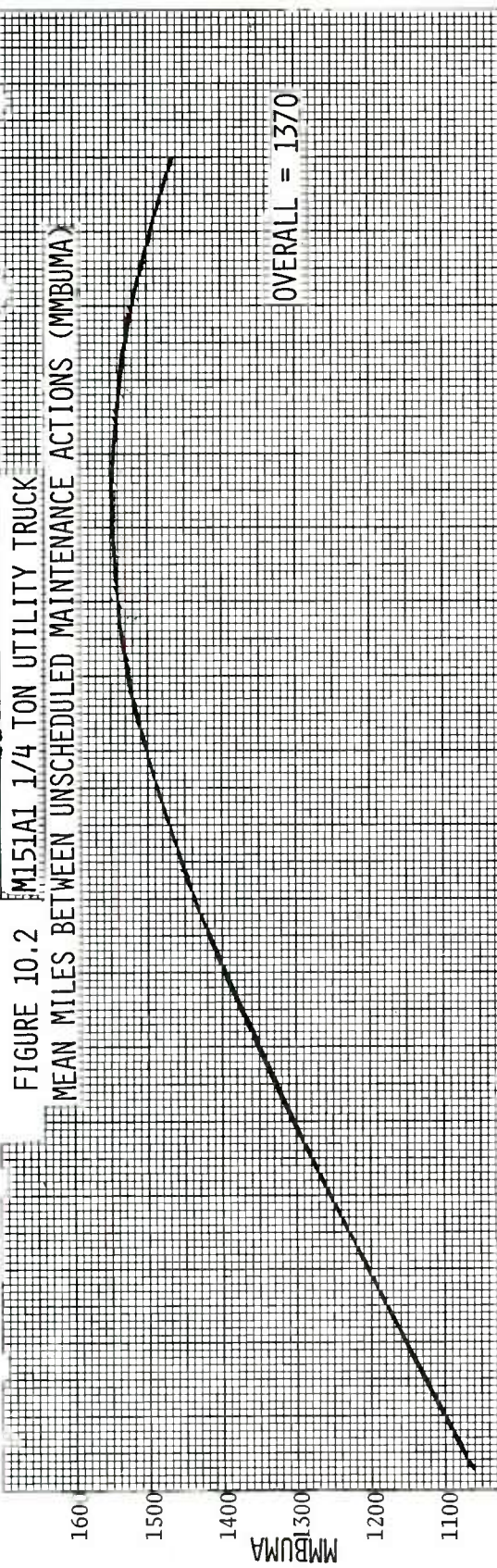

1/4 ton truck increased in mileage through 72,000 miles of usage. One interesting sidelight noted on Figure 10.2 is that the lowest MMBUMA and R_i values occur during early life of the truck. This, however, is probably due to quality control problems that generally occur with a new vehicle. In summary, it is noted that over the 72,000 miles studied, the overall MMBUMA and R_i values are 1370 and .97, respectively.

The Inherent Readiness parameter discussed above is noted to be the probability that the truck is not undergoing active repair due to an unscheduled maintenance action when called upon to operate at any point in time. This parameter, thus, does not include vehicle logistic downtime, i.e., downtime associated with obtaining and waiting for parts. This was not included in the study as it was not readily available in the TAERS data. In comparing the Inherent Readiness estimates with similar estimates obtained from a recent DARCOM Materiel Readiness Report, the R_i value compared favorably with the DARCOM Readiness Report value. For example, the R_i value of .97 as obtained in this study converts to a .98 value when transforming the man-hour indications to clock-hour indications (a conversion factor of 1.8 man-hours = 1 clock hour is used). This .98 readiness value is thus determined to be essentially the same as the DARCOM Readiness Report value of .97. The DARCOM report further notes that when logistic downtime is considered in the availability parameter, the availability of this vehicle is indicated to be .92.

10.3 Maintainability Analysis

The object of this analysis was to determine if the man-hours required for maintenance were changing as the truck increased in mileage. In addition, a parts replacement analysis was conducted. This latter analysis consisted of the following: (1) major component replacements as a function of mileage (engine, transmission, differential and generator), (2) high cost parts' (in excess of \$100.00) replacements, (3) ten most frequently replaced parts and (4) determination of the number of replacements for all vehicle parts.

Shown on Table 10.1 is a summary of the man-hour data obtained for the trucks included in the study. Of particular interest in this table is the average man-hours required per truck per 1000 miles, the average man-hours required per maintenance action and the maintenance support index (number of maintenance man-hours required per hour of truck operation); all reported by 1000 mile intervals through 72,000 miles of usage.

As can be readily observed on Table 10.1, the average maintenance man-hours required per truck per 1000 miles (and subsequently the maintenance support index) was noted to be at its highest during the initial 1000 miles of usage (11.8 and .24, respectively). This is believed due to two primary reasons: (1) the relatively large number of man-hours associated with the processing-in of a new vehicle and (2) initial quality control problems that occur with a new vehicle.

TABLE 10.1 MAINTAINABILITY DATA FOR M151A1 1/4 TON UTILITY TRUCK

MILEAGE INTERVAL (1000's)	AVERAGE NO. OF TRUCKS	NO. OF MAINT. ACTIONS (SCH. & UNSCH.)	NO. OF MAN-HRS	AVERAGE MAN-HRS PER TRUCK PER 1000 MILES	AVERAGE MAN-HRS PER MAINT. ACTION	MAINT. * SUPPORT INDEX	MILEAGE INTERVAL (1000's)	AVERAGE NO. OF TRUCKS	NO. OF MAINT. ACTIONS (SCH. & UNSCH.)	NO. OF MAN-HRS	AVERAGE MAN-HRS PER TRUCK PER 1000 MILES	AVERAGE MAN-HRS PER MAINT. ACTION	MAINT. * SUPPORT INDEX
0-1	3346	16252	39335	11.8	2.4	.24	36-37	441	1096	1952	4.4	1.8	.09
1-2	3785	9670	18668	4.9	1.9	.10	37-38	409	1030	2119	5.2	2.1	.10
2-3	4012	10571	21611	5.4	2.0	.11	38-39	366	910	1723	4.7	1.9	.09
3-4	4159	12124	26454	6.4	2.2	.13	39-40	334	170	1799	5.4	1.8	.11
4-5	4154	10707	19684	4.7	1.8	.09	40-41	284	622	1271	4.5	2.0	.09
5-4	4093	10620	19910	4.9	1.9	.10	41-42	260	574	1188	4.6	2.1	.09
6-7	4015	11836	24263	6.0	2.0	.12	42-43	232	624	1197	5.2	1.9	.10
7-8	3864	9601	17557	4.5	1.8	.09	43-44	204	446	805	4.0	1.8	.08
8-9	3697	9281	17488	4.7	1.9	.09	44-45	185	448	846	4.6	1.9	.09
9-10	3542	9714	18939	5.4	2.0	.11	45-46	167	371	798	4.8	2.2	.10
10-11	3374	9300	17528	5.2	1.9	.10	46-47	148	339	779	5.3	2.3	.11
11-12	3185	8006	14961	4.7	1.9	.09	47-48	136	303	460	3.4	1.5	.07
12-13	2986	8441	16890	5.7	2.0	.11	48-49	122	317	658	5.4	2.1	.11
13-14	2829	6955	12743	4.5	1.8	.09	49-50	110	250	560	5.1	2.2	.10
14-15	2660	6764	12769	4.8	1.9	.10	50-51	103	228	429	4.2	1.9	.08
15-16	2481	6619	12947	5.2	2.0	.10	51-52	91	268	559	6.1	2.1	.12
16-17	2311	5787	11315	4.9	2.0	.10	52-53	84	163	448	5.3	2.8	.11
17-18	2158	4969	9497	4.4	1.9	.09	53-54	75	146	322	4.3	2.2	.09
18-19	2011	5583	11022	5.5	2.0	.11	54-55	66	133	242	3.7	1.8	.07
19-20	1860	4756	8795	4.7	1.8	.09	55-56	55	130	249	4.5	1.9	.09
20-21	1732	4225	8418	4.9	2.0	.11	56-57	50	98	176	3.5	1.8	.07
21-22	1577	4176	8472	5.4	2.0	.11	57-58	43	95	229	5.3	2.4	.11
22-23	1456	3779	6874	4.7	1.8	.09	58-59	37	95	155	4.2	1.6	.08
23-24	1352	3780	6860	5.1	1.8	.10	59-60	31	98	238	6.6	2.4	.13
24-25	1248	3148	5936	4.8	1.9	.10	60-61	30	79	164	5.3	2.1	.11
25-26	1145	2906	5571	4.9	1.9	.10	61-62	25	83	148	4.9	1.8	.10
26-27	1041	2750	5499	5.3	2.0	.11	62-63	23	79	164	6.6	2.1	.13
27-28	957	2314	4461	4.7	1.9	.09	63-64	21	95	155	6.7	1.6	.13
28-29	905	2364	4433	4.9	1.9	.10	64-65	18	119	156	7.4	1.3	.15
29-30	845	2107	3695	4.4	1.8	.09	65-66	15	57	82	4.6	1.4	.09
30-31	792	1841	3899	4.9	2.1	.10	66-67	12	56	72	4.8	1.3	.10
31-32	737	1828	3676	5.0	2.0	.10	67-68	10	61	90	7.5	1.5	.15
32-33	665	1561	3094	4.6	2.0	.09	68-69	10	43	44	4.4	1.0	.09
33-34	589	1507	2891	4.9	1.9	.10	69-70	11	27	33	3.0	1.2	.06
34-35	532	1300	2724	5.1	2.1	.10	70-71	11	45	99	9.0	2.2	.18
35-36	482	1036	1930	4.0	1.9	.08	71-72	10	38	70	7.0	1.8	.14

However, the maintenance man-hours required are noted to decrease from the levels obtained during the initial 1000 miles of usage to near 5.0 man-hours during the second 1000 mile interval with the number of man-hours required for maintenance remaining relatively stable near 5.0 man-hours through 72,000 miles of usage. Thus, over 72,000 miles of usage, the average man-hours required for maintenance per truck per 1000 miles was 5.1 man-hours with the average maintenance support index being .10.

In analyzing the average man-hours required per maintenance action, it was noted that the average truck required maintenance on an unscheduled basis an average of 52.6 times over 72,000 miles and during each of these maintenance stops the truck had on the average 1.6 different components repaired, replaced or adjusted. The number of man-hours utilized for each of these components averaged 1.8 man-hours with a total of 2.9 man-hours thus required for each maintenance stop. Shown on Table 10.1 are the maintenance man-hours required for each maintenance action by 1000 mile intervals.

As noted above, an analysis of major component replacements (engine, transmission, differential and generator) was conducted. This analysis consisted of determining for these components, the number and percent replaced by increasing 1000 mile intervals (See Table 10.2). The object of this analysis was to determine if any of these major components exhibited wearout characteristics at a particular mileage or mileage interval. The results of this analysis indicated that the engine was the only major component to exhibit wearout characteristics with increasing mileage of the vehicle. Shown on Figure 10.3 is a plot of the cumulative number of engine replacements that may be expected with the 1/4 ton truck. This plot shows that over a 72,000 mile period, the average 1/4 ton truck will have sustained one engine replacement. Although the other major components studied (transmission, differential and generator) did not reveal a wearout process, it was found that there was somewhat of a consistent replacement problem with these components throughout their life (See Table 10.2). For example, the average 1/4 ton truck will sustain 1.4 transmission replacements, 1.2 differential replacements and 0.9 generator replacements over a 72,000 mile interval.

In further analysis of parts replacements, a study of the high cost parts (in excess of \$100.00) replacements was made. This analysis consisted of determining the number of replacements for all high cost components contained in the truck on an overall basis as well as by increasing 10,000 mile intervals (See Table 10.3). The object of this analysis was to determine which high cost components were being replaced most frequently and at what mileage intervals did these replacements occur. The results of this analysis indicated that the differential, generator and transmission gear/assembly were the most frequently replaced high cost components. The results further showed that relatively high replacements of these components occurred throughout the life of these components.

TABLE 10.2 MAJOR COMPONENT REPLACEMENTS FOR M151A1 1/4 TON UTILITY TRUCK

MILEAGE INTERVAL (1000'S)	AVERAGE NO. OF VEHICLES	ENGINE		TRANSMISSION		DIFFERENTIAL		GENERATOR		MILEAGE INTERVAL (1000'S)	AVERAGE NO. OF VEHICLES	ENGINE		TRANSMISSION		DIFFERENTIAL		GENERATOR	
		NUMBER REPLACED	PERCENT REPLACED	NUMBER REPLACED	PERCENT REPLACED	NUMBER REPLACED	PERCENT REPLACED	NUMBER REPLACED	PERCENT REPLACED			NUMBER REPLACED	PERCENT REPLACED	NUMBER REPLACED	PERCENT REPLACED	NUMBER REPLACED	PERCENT REPLACED	NUMBER REPLACED	PERCENT REPLACED
0-1	3346	4	.1	6	.2	16	.5	77	2.3	36-37	441	4	.9	10	2.3	9	2.0	6	1.4
1	3785	5	.1	13	.3	21	.6	86	2.3	37-38	409	2	.5	10	2.4	6	1.5	4	1.0
2-3	4012	5	.1	26	.6	19	.5	56	1.4	38-39	366	7	1.9	9	2.5	9	2.5	9	2.5
3-4	4159	5	.1	23	.6	23	.6	77	1.9	39-40	334	6	1.8	9	2.7	10	3.0	2	.6
4-5	4154	10	.2	37	.9	29	.7	76	1.8	40-41	284	4	1.4	3	1.1	3	1.1	2	.7
5-6	4093	7	.2	44	1.1	39	1.0	64	1.6	41-42	260	4	1.5	7	2.7	11	4.2	3	1.2
6-7	4015	6	.1	52	1.3	40	1.0	49	1.2	42-43	232	3	1.0	4	1.7	10	4.3	2	.9
7-8	3864	6	.2	48	1.2	27	.7	45	1.2	43-44	204	2	1.0	5	2.5	1	.5	2	1.0
8-9	3697	9	.2	24	.6	26	.7	53	1.4	44-45	185	2	1.1	8	4.3	3	1.5	3	1.6
9-10	3542	12	.3	48	1.4	26	.7	53	1.5	45-46	167	5	3.0	3	1.8	3	1.8	0	0
10-11	3374	9	.3	38	1.1	24	.7	53	1.5	46-47	148	3	2.0	2	1.4	1	.7	3	2.0
11-12	3185	8	.3	42	1.3	37	1.2	42	1.3	47-48	136	1	.7	1	1.7	2	1.5	2	1.5
12-13	2986	22	.7	47	1.6	37	1.2	31	1.0	48-49	122	6	4.9	2	1.6	3	2.5	1	.8
13-14	2829	11	.4	40	1.4	41	1.4	25	1.0	49-50	110	1	.9	1	.9	1	.9	1	.9
14-15	2660	7	.3	32	1.2	29	1.1	40	1.5	50-51	103	1	1.0	3	2.9	3	2.9	4	3.9
15-16	2481	10	.4	40	1.6	39	1.6	30	1.2	51-52	91	3	3.3	1	1.1	3	3.3	4	4.4
16-17	2311	7	.3	41	1.8	34	1.5	27	1.2	52-53	84	1	1.2	0	0	0	0	0	0
17-18	2158	5	.2	32	1.5	28	1.3	27	1.3	53-54	75	0	0	1	1.3	0	0	2	2.7
18-19	2011	9	.4	32	1.6	26	1.3	32	1.6	54-55	66	3	4.5	1	1.5	0	0	0	0
19-20	1860	14	.8	25	1.3	28	1.5	26	1.4	55-56	55	1	1.8	0	0	1	1.8	1	1.8
20-21	1732	10	.6	34	2.0	27	1.6	16	.9	56-57	50	1	2.0	0	0	0	0	0	0
21-22	1577	8	.5	30	1.9	23	1.5	20	1.3	57-58	43	1	2.3	0	0	0	0	1	2.3
22-23	1456	9	.6	35	2.4	22	1.5	17	1.2	58-59	37	0	0	0	0	0	0	0	0
23-24	1352	7	.5	26	1.9	28	2.1	20	1.5	59-60	36	0	0	1	2.8	0	0	0	0
24-25	1248	8	.6	22	1.8	19	1.5	16	1.3	60-61	31	0	0	0	0	0	0	0	0
25-26	1145	9	.8	24	2.1	24	2.1	24	2.1	61-62	30	0	0	0	0	0	0	0	0
26-27	1041	6	.6	14	1.3	14	1.3	9	.9	62-63	25	0	0	1	4.0	0	0	0	0
27-28	957	6	.6	11	1.1	12	1.2	15	1.6	63-64	23	0	0	2	8.7	0	0	0	0
28-29	905	6	.7	21	2.3	20	2.2	13	1.4	64-65	21	0	0	1	4.8	0	0	0	0
29-30	845	5	.6	8	.9	14	1.7	10	1.2	65-66	18	0	0	0	0	0	0	0	0
30-31	792	7	.9	19	2.4	11	1.4	6	.8	66-67	15	0	0	0	0	0	0	0	0
31-32	737	11	1.5	18	2.4	11	1.4	14	1.9	67-68	12	1	8.3	1	8.3	0	0	0	0
32-33	665	4	.6	9	1.4	17	2.6	5	.8	68-69	10	0	0	0	0	0	0	0	0
33-34	589	6	1.0	8	1.4	4	.7	5	.8	69-70	11	0	0	0	0	0	0	0	0
34-35	532	3	.6	5	.9	9	1.7	10	1.9	70-71	11	0	0	0	0	0	0	0	0
35-36	482	1	.2	11	2.3	5	1.0	1	.2	71-72	10	0	0	0	0	0	0	0	0

FIGURE 10.3

CUMULATIVE NUMBER OF ENGINE REPLACEMENTS
FOR MISIAI 1/4 TON UTILITY TRUCK^H

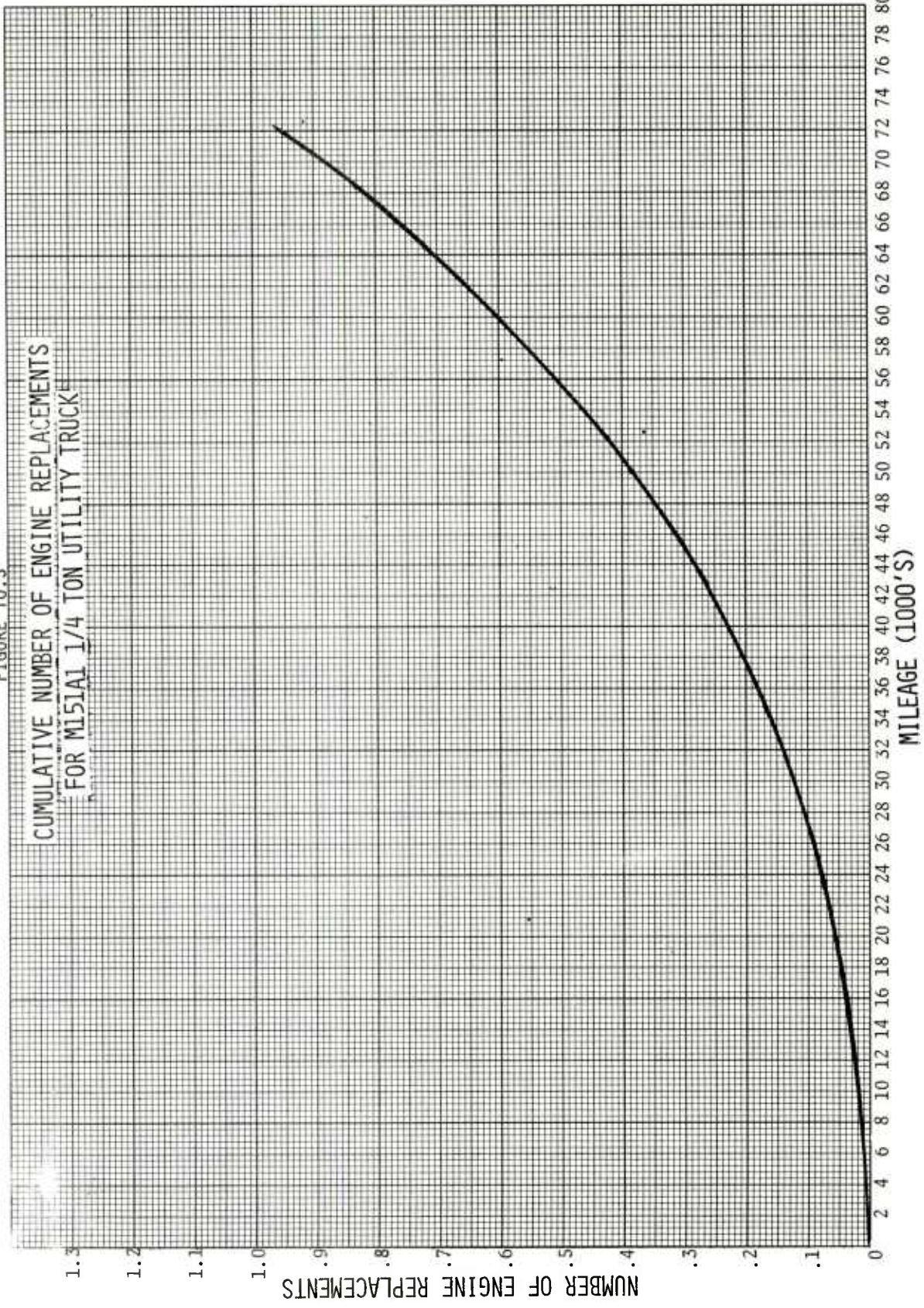

TABLE 10.3 HIGH COST PART REPLACEMENTS FOR M151A1 1/4 TON UTILITY TRUCK

PART FSN	PART NOMENCLATURE	COST (DOLLARS)	NUMBER REPLACEMENTS									
			TOTAL	MILEAGE INTERVAL* (1000'S)							OVER 70	
				0-10	10-20	20-30	30-40	40-50	50-60	60-70		
28058868083	ENGINE ASSEMBLY	1051	165	27	54	39	19	20	5	1	0	
25407801972	HARDTOP	772	1	1	0	0	0	0	0	0	0	
28056781820	ENGINE ASSEMBLY	751	174	42	48	35	32	11	6	0	0	
29207872380	KIT GEN	640	7	6	1	0	0	0	0	0	0	
25209103118	TRANSFER ASSY	424	1	0	0	0	0	0	0	0	0	
25403017268	HEATER	401	4	3	1	0	0	0	0	0	0	
25200402595	ASSY, FRONT END	321	1	0	0	1	0	0	0	0	0	
62307618697	CONVERTER	317	4	4	0	0	0	0	0	0	0	
25206781808	TRANSMISSION GEAR	295	792	244	276	174	74	20	2	4	0	
25208871354	TRANSMISSION ASSY	295	279	77	95	51	34	16	5	1	0	
25407645917	HEATER KIT	223	81	65	13	2	1	0	0	0	0	
25204561596	HOUSING	217	1	0	1	0	0	0	0	0	0	
25106732978	WINDSHIELD	189	1	0	1	0	0	0	0	0	0	
25106781806	ARM ASSEMBLY	174	16	8	1	3	1	3	0	0	0	
25309798896	ARM ASSEMBLY, LEFT	174	5	1	3	0	1	0	0	0	0	
29209999324	GENERATOR	172	14	8	3	2	1	0	0	0	0	
29209092484	GENERATOR	167	25	14	6	4	1	0	0	0	0	
25206783123	DIFFERENTIAL	157	926	266	323	203	90	36	8	0	0	
29906783123	DIFFERENTIAL	157	1	1	0	0	0	0	0	0	0	
29203140556	GENERATOR	148	55	34	12	7	1	1	0	0	0	
25309798897	ARM SUSPENSION	126	8	1	3	2	2	0	0	0	0	
29209039534	GENERATOR	114	197	102	56	24	12	1	2	0	0	
25101190846	SUSPENSION	109	2	0	1	0	1	0	0	0	0	
25402884963	HEATER ASSEMBLY	109	3	1	2	0	0	0	0	0	0	
25907886262	KIT, DOOR	103	88	60	21	2	2	1	0	1	1	
29206781847	GENERATOR	100	23	10	7	4	2	0	0	0	0	
29207355736	GENERATOR	100	118	75	34	4	3	2	0	0	0	
29207374750	GENERATOR	100	560	319	143	59	26	8	5	0	0	

*VEHICLE MILEAGE (MILLIONS) FOR EACH MILEAGE INTERVAL IS:

0-10:	38.24
10-20:	25.66
20-30:	12.18
30-40:	5.31
40-50:	1.84
50-60:	0.64
60-70:	0.20
OVER 70:	0.09

OVERALL: 84.16

As indicated above, the parts analysis also included a determination of the ten most frequently replaced components in these trucks (see Table 10.4). As noted on these tables, the ten most frequently replaced components are shown by 10,000 mile intervals as well as on an overall basis. This is done in order to determine if the components being replaced in the initial 10,000 mile interval are also being replaced in subsequent 10,000 mile intervals. For example, the carburetor, battery and wheel bearings were on an overall basis the three most frequently replaced components. The components were also noted to be among the most frequently replaced in almost every 10,000 mile interval. Also noted on these tables, alongside the replaced part, is the actual number of parts that were replaced. This value may be compared to the total vehicle mileage in the interval, shown on the bottom of the table, so that the significance of the value can be determined. In addition to this list of ten most frequently replaced parts, a list of the number of replacements for all components of the trucks included in the study is being compiled and will be published in a later report.

11. PROFILE OF AN AVERAGE M151A1 1/4 TON TRUCK

The average M151A1 1/4 ton truck during the initial 72,000 miles of usage will sustain a total maintenance cost (for both scheduled and unscheduled maintenance) of \$4700 or an average maintenance cost of 6.5¢ per mile. The average maintenance cost will be noted to be increasing during the initial 72,000 miles from 5.4¢ per mile at 1000 miles to 8.3¢ per mile at 72,000 miles. It was noted that the increasing cost per mile was entirely due to increased costs associated with engine replacements.

During the 72,000 miles of usage, the average truck will have 52.6 UMA's with the mean miles between UMA of 1370 miles. When the 1/4 ton truck is in the maintenance shop for a UMA, on the average 1.6 different parts will be repaired, replaced or adjusted. During the average UMA 1.8 man-hours will be expended for each part worked on and thus a total of 2.9 man-hours will be expended during an average UMA.

For each 1000 miles of usage, an average of 5.1 man-hours of maintenance (scheduled and unscheduled) are required. Of these man-hours, 3.0 man-hours are for scheduled maintenance and 2.1 man-hours are for unscheduled maintenance. For every hour of truck operation (assuming an average speed of 20 mph), the 1/4 ton truck on the average requires .10 man-hours of maintenance.

During 72,000 miles of usage, the major components of the average truck will have exhibited the following: (1) the engine will have been replaced 1.0 times, (2) the transmission will have been replaced 1.4 times, (3) the differential will have been replaced 1.2 times and (4) the generator will have been replaced 0.9 times.

TABLE 10.4 TEN MOST FREQUENTLY REPLACED PARTS FOR M151A1 1/4 TON UTILITY TRUCK

ORDER	MILEAGE INTERVAL* (1000's)										OVERALL
	0-10	10-20	20-30	30-40	40-50	50-60	60-70	Over 70			
1	REGULATOR (2237)	WHEEL BEARINGS (1312)	WHEEL BEARINGS (781)	WHEEL BEARINGS (333)	WHEEL BEARINGS (106)	WHEEL BEARINGS (48)	WHEEL BEARINGS (31)	BRAKE SHOES (31)	PARTS KIT, U- JOINT (12)	CARBURETOR (3912)	
2	CARBURETOR (2128)	BRAKE SHOES (1303)	BRAKE SHOES (724)	BRAKE SHOES (314)	PARTS, KIT, WHEEL (78)	BRAKE SHOES (37)	WHEEL BEARINGS (22)	WHEEL BEARINGS (22)	WHEEL FLANGE (10)	BATTERY (3692)	
3	BATTERY (1757)	BATTERY (1116)	BATTERY (495)	BATTERY (226)	SOCKET ASSY. LOW (73)	PARTS KIT, U- JOINT (29)	BRAKE DRUMS (17)	BRAKE DRUMS (17)	BRAKE SHOES (10)	WHEEL BEARINGS (3529)	
4	PARTS KIT, GEAR (1642)	CARBURETOR (1066)	SEAT (470)	PLUG, PROTECTOR (187)	BRAKE SHOES (69)	SEAL SET (27)	CYLINDER (17)	CYLINDER (17)	PARTS KIT, WHEEL (10)	REGULATOR (3496)	
5	LAMP, INCAND. (1393)	SEAT (995)	CARBURETOR (449)	CARBURETOR (186)	PARTS KIT, U- JOINT (66)	DISTRIBUTOR (26)	SOCKET ASSY. LOW (17)	SOCKET ASSY. LOW (17)	SOCKET ASSY. LOW (9)	BRAKE SHOES (3461)	
6	GASKET SET (1367)	DISTRIBUTOR (888)	DISTRIBUTOR (413)	DISTRIBUTOR (183)	BATTERY (63)	SOCKET ASSY. LOW (24)	SEAL SET (16)	SEAL SET (16)	LAMP, INCAN LAMP, INCAND. (6)	PARTS KIT, GEAR (2888)	
7	LIGHT SWITCH (1342)	PLUG, PROTECTOR (885)	SOCKET ASSY., LOW (409)	PARTS KIT, U- JOINT (182)	PLUG, PROTECTOR (56)	BATTERY (23)	DISTRIBUTOR (14)	DISTRIBUTOR (14)	SEAL SET (5)	LAMP, INCAND. (2589)	
8	DISTRIBUTOR (1010)	PARTS KIT, WHEEL (830)	PLUG, PROTECTOR (398)	SOCKET ASSY., LOW (169)	CARBURETOR (56)	PARTS KIT, (21)	PARTS KIT, WHEEL (13)	PARTS KIT, WHEEL (13)	PARTS KIT, IDLER (5)	DISTRIBUTOR (2587)	
9	BRAKE SHOES (973)	SOCKET ASSY., LOW (817)	PARTS KIT, U- JOINT (396)	PARTS KIT WHEEL (144)	SEAL SET (50)	CYLINDER (19)	SEAT (11)	SEAT (11)	BATTERY (4)	SEAT (2516)	
10	WHEEL BEARINGS (925)	REGULATOR (810)	PARTS KIT, WHEEL (387)	UNIVERSAL WHEEL (136)	DISTRIBUTOR (49)	GASKET SET (19)	SOCKET ASSY., UP. (11)	SOCKET ASSY., UP. (11)	CYLINDER (4)	LIGHT SWITCH (2469)	

*VEHICLE MILEAGE (MILLIONS) FOR EACH MILEAGE INTERVAL IS:

0-10	38.24
10-20	25.66
20-30	12.18
30-40	5.31
40-50	1.84
50-60	0.64
OVER 70	0.09
OVERALL	84.16

From an availability and reliability standpoint, there is a .97 probability that the average truck will not be undergoing active repair due to a UMA at any point in time and a .95 probability that the truck will complete a random 75 miles without a UMA.

12. COMPARISON OF TAERS AND SDC DATA

The principal data sources being used in this study, as indicated in paragraph 3, were the TAERS and Sample Data Collection (SDC) systems. As noted throughout this report, the TAERS data for 8,345 vehicles was the primary data source from which the useful life of the 1/4 ton truck was determined. This was done because the TAERS data were collected over a five year period for a large number of vehicles with many of these vehicles accumulating substantial mileage during this time frame. The SDC data, although being data of a later vintage (1972-75) contained substantially fewer vehicles with much less mileage accumulation. The SDC vehicles, however, were useful for providing some confirmation of the results obtained from the screened TAERS data. As a result, a comparison of certain key parameters obtained from TAERS and SDC was made. A summary of these comparisons is shown on Table 12.1. As noted on this table, the data generated from the analysis of the M151A1 1/4 ton TAERS data are compared with similar M151A1 data generated from the SDC program. In addition, M151A2 1/4 ton truck data obtained from SDC program are also shown. As seen in this table the screened TAERS data compare favorably with the SDC data.

TABLE 12.1 TAERS VS. SDC

<u>TAERS (A1)*</u>	<u>Parameter</u>	<u>SDC**</u>	
		<u>A1</u>	<u>A2</u>
6.5¢	Maint. Cost Per Mile	6.8¢	4.9¢
1370	MMBUMA	1018	1288
.97	Inherent Readiness	.97	.98
5.1	Manhours/1000 Miles	4.0	3.3
.10	Maint. Support Index	.08	.07

*TAERS data from AMSAA Vehicle Average Useful Life Study

**SDC data from AMMC Final Summary Report for Period 1 Feb 72 - 31 Jan 75

APPENDIX

General Weighted Multiple Linear Regression

Under this analysis the data are considered to consist of k ordered $(r+2)$ - tuples $(y_1, n_1, x_{11}, x_{12}, x_{13}, \dots, x_{1r})$, $(y_2, n_2, x_{21}, x_{22}, x_{23}, \dots, x_{2r})$, \dots , $(y_k, n_k, x_{k1}, x_{k2}, x_{k3}, \dots, x_{kr})$ where y_i is the i -th observation of the dependent variable (the variable to be predicted), n_i is the sample size for the i -th observation, and x_{ij} is the i -th observation for the j -th independent variable (variables to be used for future predictions) $i=1,2,3,\dots,k$ and $j=1,2,3,\dots,r$. It is assumed that the dependent variable y_i can be expressed as a linear function of the x_{ij} plus a random variable ϵ_i . Thus, the model is

$$y_i = \beta_0 + x_{i1}\beta_1 + x_{i2}\beta_2 + \dots + x_{ir}\beta_r + \epsilon_i.$$

However, since the precision of the i -th observation is dependent upon its sample size n_i , a transformation of the data is necessary to remove this dependency and obtain equality of variances. The model then becomes

$$y_i^* = x_{i0}^*\beta_0 + x_{i1}^*\beta_1 + x_{i2}^*\beta_2 + \dots + x_{ir}^*\beta_r + e_i$$

where $y_i^* = \sqrt{n_i}y_i$

$$x_{i0}^* = \sqrt{n_i}$$

$$x_{ij}^* = \sqrt{n_i}x_{ij}$$

or in matrix notation

$$\tilde{y} = \tilde{X}\tilde{\beta} + \tilde{e} \tag{1}$$

where

$$\tilde{y} = \begin{bmatrix} y_1^* \\ y_2^* \\ \vdots \\ y_k^* \end{bmatrix} \quad \tilde{\beta} = \begin{bmatrix} \beta_0 \\ \beta_1 \\ \vdots \\ \beta_r \end{bmatrix} \quad \tilde{e} = \begin{bmatrix} e_1 \\ e_2 \\ \vdots \\ e_k \end{bmatrix}$$

$$\tilde{X} = \begin{bmatrix} x_{10}^* & x_{11}^* & x_{12}^* & \cdots & x_{1r}^* \\ x_{20}^* & x_{21}^* & x_{22}^* & \cdots & x_{2r}^* \\ \vdots & \vdots & \vdots & \cdots & \vdots \\ x_{k0}^* & x_{k1}^* & x_{k2}^* & \cdots & x_{kr}^* \end{bmatrix}$$

The e_i are assumed to be uncorrelated ($E(e_i e_j) = 0$ for $i \neq j$) and normally distributed random variables with mean zero and variance σ^2 . The independent variables are assumed to be controlled or measured accurately and are therefore relatively free of error. The unknown parameters in the model $\beta_0, \beta_1, \beta_2, \dots, \beta_r$ are estimated by the method of least squares. Let $b = (b_0, b_1, b_2, \dots, b_r)^T$ be the column vector of the required estimates, then these estimates have the property that they minimize the expression

$$S = \sum_{i=1}^k (y_i^* - \sum_{j=0}^r x_{ij}^* b_j)^2$$

or in matrix notation

$$S = || \tilde{y} - \tilde{X}\tilde{b} ||^2 \quad (2)$$

where $||v||$ denotes the norm of the vector v .

In order to find the required estimates of β_2 ($v = 0, 1, 2, \dots, r$), we set the partial derivatives of S with respect to b_v equal to zero.

$$\frac{\partial S}{\partial b_v} = -2 \sum_{i=1}^k (y_i^* - \sum_{j=0}^r x_{ij}^* b_j) x_{iv} = 0$$

or

$$\sum_{i=1}^k \sum_{j=0}^r x_{iv}^* x_{ij}^* b_j = \sum_{i=1}^k x_{iv}^* y_i^*$$

These $r+1$ simultaneous equations corresponding to $v = 0, 1, 2, \dots, r$ are called the normal equations in regression analysis. In matrix notation the normal equations may be written.

$$\tilde{X}^T \tilde{X} \tilde{b} = \tilde{X}^T \tilde{y} \quad (3)$$

where \tilde{X}^T is the transpose of \tilde{X} .

$$\text{Let } (\tilde{X}^T \tilde{X})^{-1} = \begin{bmatrix} c_{00} & c_{01} & c_{02} & \dots & c_{0r} \\ c_{10} & c_{11} & c_{12} & \dots & c_{1r} \\ \vdots & \vdots & \vdots & \dots & \vdots \\ \vdots & \vdots & \vdots & \dots & \vdots \\ c_{r0} & c_{r1} & c_{r2} & \dots & c_{rr} \end{bmatrix}$$

be the inverse of the matrix $\tilde{X}^T \tilde{X}$. Then the required estimate of $\tilde{\beta}$ is given by

$$\tilde{b} = \left(\tilde{X}^T \tilde{X} \right)^{-1} \tilde{X}^T \tilde{y} \quad (4)$$

Since the b_j ($j = 0, 1, 2, \dots, r$) are only estimates of the unknown constants β_j , computed from the observed data, they are subject to variation if a new set of data became available and the same procedure was applied to

this data. Then the b_j are random variables and it can be shown that the mean or expected value of b_j is equal to β_j , i.e., $E(b_j) = \beta_j$. Estimates of the standard deviation of b_j are obtained as follows:

$$s_{b_0} = s \sqrt{c_{00}} \quad (5)$$

$$s_{b_1} = s \sqrt{c_{11}}$$

$$\vdots$$

$$s_{b_r} = s \sqrt{c_{rr}}$$

where

$$s = \sqrt{\frac{1}{k-r-1} [\tilde{y}^T \tilde{y} - b\tilde{X}^T \tilde{y}]} \quad (6)$$

Under the assumptions made for the regression model, $(b_j - \beta_j)/s_{b_j}$ has the Student's t-distribution with $k-r-1$ degrees of freedom. This fact can be used to construct a confidence interval estimate of the unknown parameter β_j . Then

$$b_j \pm t_{1-\frac{\alpha}{2}, k-r-1} s_{b_j} \quad (7)$$

is a $(1-\alpha)$ 100% confidence interval for β_j , where $t_{1-\frac{\alpha}{2}, k-r-1}$ is the

$1-\frac{\alpha}{2}$ percentile of the Student's t-distribution with $k-r-1$ degrees of freedom¹. The interpretation of this interval is that if intervals of this type are repeatedly constructed following this procedure, $(1-\alpha)$ 100% of these intervals will contain the population parameter β_j being estimated. This confidence interval can also be used to test the hypothesis that $\beta_j = \beta^0$ where β^0 is a given constant. If the interval obtained from Equation (7) contains β^0 , then we would accept the hypothesis $H_0: \beta_j = \beta^0$. If the interval does not contain β^0 , then we would reject this hypothesis. This test criterion has the property that if β_j actually equals β^0 then the probability that the hypothesis $H_0: \beta_j = \beta^0$ will be rejected is equal to α (assuming a $(1-\alpha)$ 100% confidence interval) and the probability that $H: \beta_j = \beta^0$ will be

rejected if β_j equals any other given number can be computed using the non-central t-distribution². An important special case is that of the null hypothesis, i.e., $H_0 = \beta_j = 0$. If based on a test of significance $H_0: \beta_j = 0$ is accepted, β_j might be considered to be dropped from the model since it does not appear to be making a significant contribution to the estimation of the dependent variable.

Under the original model, the mean or expected value of y for a given value of (x_1, x_2, \dots, x_r) is

$$E(y) = \beta_0 + \beta_1 x_1 + \beta_2 x_2 + \dots + \beta_r x_r$$

where $\beta_0, \beta_1, \beta_2, \dots, \beta_r$ are the unknown parameters to be estimated. Thus,

$$\hat{y} = b_0 + b_1 x_1 + b_2 x_2 + \dots + b_r x_r \quad (8)$$

gives an estimate of the mean value of y for a given value of (x_1, x_2, \dots, x_r) .

Assumptions for Economic Replacement Policy

The methodology utilized in the cost analysis assumes the existence of a relative equality of certain measurable parameters. Specifically, it is assumed that an equality of economic benefits derived from performance parameters exists throughout the economic or useful life of the vehicle. Thus, the useful life of the vehicle is determined by minimizing a cost function with respect to mileage rather than maximizing a benefit cost function. Also, since there exists a functional relationship between factor or investment price and amount or quantity demanded, there is an implied assumption of relative equality of demand for the item over the duration of the replacement interval. This would ensure that both fixed and variable cost factors would be of a continuous nature over the economic life. Finally, it should be noted that this methodology is applicable for continuous replacement with vehicles having similar costs or variable and fixed cost factors that remain in proportion. Proportionate changes of these cost factors over yearly intervals will shift the cost axis but will not affect the mileage criterion.

Next page is blank.

REFERENCES

1. Scheffé, Henry, The Analysis of Variance, John Wiley and Sons, Inc., New York, 1959.
2. Resnikoff and Lieberman, Tables of the Non-Central t-Distribution, Stanford University Press, Stanford, California, 1957.
3. Draper and Smith, Applied Regression Analysis, John Wiley and Sons, Inc., New York, 1966.
4. Stonier and Hague, Economic Theory, John Wiley and Sons, Inc., New York, 1953.
5. Grawoig, Dennis E., Decision Mathematics, McGraw-Hill Book Company, New York, 1967.
6. Crow, Larry H., Weibull Reliability Procedures For Complex, Repairable Systems, AMSAA Technical Report No. 81, December 1975.
7. Bell, Raymond; Mioduski, Robert E.; Belbot, Edward F.; Rosati, Robert A.; Crow, Larry H., Vehicle Average Useful Life Study for Truck, Cargo: 2 1/2 Ton, 6x6, M35A2, AMSAA Technical Memorandum No. 163, October 1973.
8. Bell, Raymond; Mioduski, Robert E.; Belbot, Edward F., Vehicle Average Useful Life Study for Truck, 5 Ton, 6x6, M39A2 Series, AMSAA Technical Report No. 128, June 1975.
9. Belbot, Edward F., Computer Documentation for the Vehicle Average Useful Life Study, AMSAA Technical Report No. 141, August 1975.

Next page is blank.

DISTRIBUTION LIST

<u>No. of Copies</u>	<u>Organization</u>	<u>No. of Copies</u>	<u>Organization</u>
12	Commander Defense Documentation Center ATTN: TIPCR Cameron Station Alexandria, VA 22314	1	Commander U S Army Materiel Development and Readiness Command ATTN: DRCBSI-D 5001 Eisenhower Avenue Alexandria, VA 22333
1	Commander U S Army Materiel Development and Readiness Command ATTN: DRCCP 5001 Eisenhower Avenue Alexandria, VA 22333	1	Commander U S Army Materiel Development and Readiness Command ATTN: DRCDE-R 5001 Eisenhower Avenue Alexandria, VA 22333
1	Commander U S Army Materiel Development and Readiness Command ATTN: DRCDE-F 5001 Eisenhower Avenue Alexandria, VA 22333	1	Commander U S Army Materiel Development and Readiness Command ATTN: DRCPA-P 5001 Eisenhower Avenue Alexandria, VA 22333
1	Commander U S Army Materiel Development and Readiness Command ATTN: DRCRE-I 5001 Eisenhower Avenue Alexandria, VA 22333	1	Commander U S Army Materiel Development and Readiness Command ATTN: DRCMM-MS, Mr. D. Taber 5001 Eisenhower Avenue Alexandria, VA 22333
1	Commander U S Army Materiel Development and Readiness Command ATTN: DRCBSI-L 5001 Eisenhower Avenue Alexandria, VA 22333	1	Commander U S Army Materiel Development and Readiness Command ATTN: DRCDE-D 5001 Eisenhower Avenue Alexandria, VA 22333
1	Commander U S Army Materiel Development and Readiness Command ATTN: DRCPA-S 5001 Eisenhower Avenue Alexandria, VA 22333	10	HQDA (DALO-SMD, LTC R. Webster) WASH DC 20314
		5	HQDA (DALO-SML, Mr. W. Nicols) WASH DC 20310
1	Commander U S Army Materiel Development and Readiness Command ATTN: DRCQA 5001 Eisenhower Avenue Alexandria, VA 22333		

DISTRIBUTION LIST (Continued)

<u>No. of Copies</u>	<u>Organization</u>	<u>No. of Copies</u>	<u>Organization</u>
1	Commander U S Army Tank-Automotive Materiel Readiness Command ATTN: DRSTA-MSA, 1LT R. Sirtak Warren, MI 48090	1	Chief, Analytical Sciences Office USA Biological Defense Research Laboratory ATTN: DRXBL-AS Dugway, UT 84022
1	Commander U S Army Tank-Automotive Materiel Readiness Command ATTN: DRSTA-VL, Mr. D. Palmer Warren, MI 48090	1	Commander U S Army Aviation R&D Command ATTN: DRSAV-D PO Box 209 St. Louis, MO 63166
1	Commander U S Army Maintenance Management Center ATTN: DRXMD-MT, Mr. E. Jackson Lexington, KY 40507	1	Commander U S Army Electronics Command ATTN: DRSEL-SA Fort Monmouth, NJ 07703
1	Commander U S Army Materiel Readiness Command ATTN: DRSAR-SA Rock Island, IL 61201	2	Director US Army TRADOC Systems Analysis Activity ATTN: ATAA-SA ATAA-T White Sands Missile Range, NM 88002
1	Commander Rock Island Arsenal ATTN: SARRI-L (Tech Lib) Rock Island, IL 61201	1	Commander U S Army Missile R&D Command ATTN: DRSMI-C Redstone Arsenal, AL 35809
1	Commander Harry Diamond Laboratories ATTN: DRXDO-SAB 2800 Powder Mill Road Adelphi, MD 20783	1	Commander U S Army Troop Support & Aviation Materiel Readiness Comd ATTN: DRSTS-F 4300 Goodfellow Blvd St. Louis, MO 63120
1	Commander U S Army Mobility Equipment Research and Development Command ATTN: DRXFB-O Fort Belvoir, VA 22060	1	Commander U S Army Tank-Automotive R&D Command ATTN: DRDTA-UL (Tech Lib) DRDTA-V Warren, MI 48090

DISTRIBUTION LIST (Continued)

<u>No. of Copies</u>	<u>Organization</u>	<u>No. of Copies</u>	<u>Organization</u>
1	Commander U S Army Natick Research and Development Command ATTN: DRXNM-O Natick, MA 01760	2	Chief, Defense Logistics Studies Information Exchange U S Army Logistics Management Center ATTN: DRXMC-D Fort Lee, VA 23801
	<u>Aberdeen Proving Ground</u>	1	Commandant U S Army Transportation School ATTN: ATSP-CD-CS (MAJ Andresen) Ft Eustis, VA 23604
	CDR, USATECOM ATTN: DRSTE, DRSTE-CS-A Bldg 314		
	Ch, Tech Lib, Bldg 305		
	Dir, BRL, Bldg 328		
	Dir, HEL, Bldg 520		