

AD-A049 830

NAVY ELECTRONICS LAB SAN DIEGO CALIF
DIRECTIVITY PATTERNS OF A 5-ELEMENT LINEAR SUPER-DIRECTIVE ARRANGEMENT (U)
APR 63 R P KEMPF
NEL-TM-599

F/G 17/1

UNCLASSIFIED

NL

| OF |
AD
AD49 830

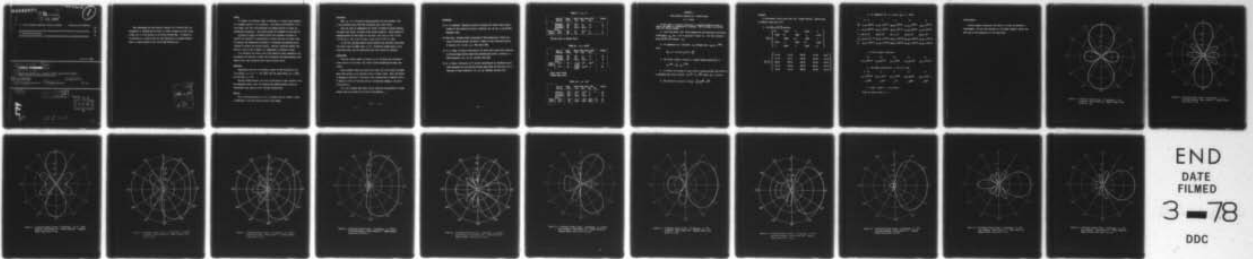

END
DATE
FILMED
3 - 78
DDC

AD A 049830

MOST Project-2



AD No. _____
DDC FILE COPY

4058

U. S. NAVY ELECTRONICS LABORATORY, SAN DIEGO, CALIFORNIA • A BUREAU OF SHIPS LABORATORY

The opinions expressed herein are those of the author(s) and are not necessarily the official views of the U. S. Navy Electronics Laboratory
If cited in the scientific literature, this document should be described as an unpublished memorandum.

NEL/TM 599

Good

041020-0576

TECHNICAL MEMORANDUM

14
NEH-
TM-599

6
DIRECTIVITY PATTERNS OF A 5-ELEMENT LINEAR SUPER-DIRECTIVE ARRAY USING PRITCHARD AND BRYN SHADING METHODS.

11
15 April 1963

10
R. P. Kempff (Code 3130)

17
SF 001 03 04 (8051)

16
F00103

NEL L3-2

12
25p.

DISTRIBUTION STATEMENT A
Approved for public release
Distribution Unlimited

DDC
RECEIVED
FEB 13 1978
RECEIVED
A

599

4-9

253 550

1B

This memorandum has been prepared because it is believed that the information it contains may be useful to others working in allied fields at NEL, and to a few persons or activities outside NEL. It should not be construed as a report since its only function is to present information on a small portion of the work on NEL Problem L3-2.

ACCESSION FOR	
DTIC	White Section <input checked="" type="checkbox"/>
DDC	Sub Section <input type="checkbox"/>
UNANNOUNCED	<input type="checkbox"/>
JUSTIFIED	
<i>Letter on file</i>	
BY	
DISTRIBUTION/AVAILABILITY CODES	
GEN	AVAIL. CODE SPECIAL
<i>A</i>	<i>23</i> <i>E.L.</i>

OBJECT

To compare two different types of shading for a linear array composed of 5 elements spaced at $\lambda/4$ intervals. One method by Pritchard⁽¹⁾ sets a fixed minor lobe level and determines the shading factors by using the Tschebycheff polynomial. The second method was developed by Finn Bryn⁽²⁾.

Pritchard's method of shading follows the procedure developed by Dolph⁽³⁾ and Riblet⁽⁴⁾ in prescribing a certain level for all minor lobes and employs the Tschebycheff polynomial to determine the shading factors required to produce the desired pattern. However, Pritchard extends this method so that it may be applied to compensated or "steered" arrays.

Bryn considers the second order cross moment of noise received at two hydrophones and develops a method which implements the Neyman-Pearson likelihood ratio, thus optimizing this signal-to-noise ratio.

PROCEDURE

Comparisons were made for patterns steered in the direction of the array normal, i.e., $\theta_c = 0^\circ$; for 32.25° from the array normal, $\theta_c = 32.25^\circ$; and end fire, $\theta_c = 90^\circ$.

The Bryn method assumes electronic system noise of less intensity than the background noise, while the unshaded and shaded patterns using the Tschebycheff type shading do not consider system noise.

RESULTS

The calculated patterns as shown in figures 1-15 and tables 1-3 give a comparison of the beam width and minor lobe levels.

DISCUSSION

When $\theta_c = 0^\circ$, Pritchard's shading produces the best pattern, that is the narrowest beam width with acceptable minor lobe levels.

When the array is compensated for 32.25° , Pritchard's method produces low minor lobe levels, but beam widths become excessive. Bryn's method of shading narrows the beam width but the minor lobe level at $+90^\circ$ is only -3.6 db and at -90° is 8.7 db when a noise ratio of 10^{-5} is used.

At end fire operation Bryn's method produces the narrowest beam widths with minor lobes no higher than -11 db. Pritchard's method gives a very broad beam width, but the prescribed minor lobe levels are realized.

CONCLUSIONS

From the limited number of results, it is concluded that Pritchard's method results in low minor lobe levels without broadening the main lobe unduly.

Bryn's method results in narrow main lobes, but at the price of higher minor lobe levels, or an increased number of minor lobes. Also, the method of shading is sensitive to the noise ratio (system noise to ambient noise). A change in either or both may produce a substantial change in the directivity pattern.

It is not intended that these results should be extrapolated to longer arrays; each array needs to be studied individually.

REFERENCES

- (1) R. L. Fritchard, "Optimum Directivity Patterns for Linear Point Arrays", *Journal of the Acoustical Society of America*, Vol. 25, No. 5, pp 879-891, September 1953.
- (2) Finn Bryn, "Optimum Signal Processing of Three-Dimensional Arrays Operating on Gaussian Signals and Noise", *Journal of the Acoustical Society of America*, Vol. 34, No. 3, p. 289, March 1962.
- (3) C. L. Dolph, "A Current Distribution for Broad side Arrays which Optimizes the Relationship Between Beam Width and Side-Lobe Level", *Institute of Radio Engineers*, Vol. 34, pp. 335-346, June 1946.
- (4) H. J. Riblet, discussion on "A Current Distribution for Broadside Arrays which Optimizes the Relationship Between Beam Width and Side-Lobe Level", *Institute of Radio Engineers*, Vol, 35, pp. 489-492, Jan-June 1947.

TABLE I. - $\theta_c = 0^\circ$

	Type of shading	Beam width	Minor Lobe Levels (db)			Figure
			1st	2nd	3rd	
	Unshaded	42°	-14.1	---	---	1
	Pritchard	30°	-15	-15	---	2
	Pritchard	34°	-24.6	-24.6	---	3
	Bryn					
*Noise ratio	10 ⁻⁵	28°	-11	-6.8	---	4
	10 ⁻²	32°	-13	---	---	5

*System noise to ambient noise.

TABLE II. - $\theta_c = 32.25^\circ$

	Type of Shading	Beam width	Minor Lobe Levels (db)			Figure
			1st	2nd	3rd	
	Unshaded	54°	-12	---	---	6
	Pritchard	53°	-15	-15	---	7
	Pritchard	64°	-24.6	-24.6	---	8
	Bryn					
Noise Ratio	10 ⁻⁵	29°	-13.1*	-15**	-8.7*	9
	10 ⁻²	35°	-3.6** -12.6* -15**	-14.6*	---	10

*Left minor lobes.

**Right minor lobe.

TABLE III. - $\theta_c = 90^\circ$

	Type of shading	Beam width	Minor Lobe Level (db)				Figure
			1st	2nd	3rd	4th	
	Unshaded	100°	-11.8	-13.6	---	---	11
	Pritchard	103°	-15	-15	---	---	12
	Pritchard	112°	-24.6	-24.6	---	---	13
	Bryn						
Noise ratio	10 ⁻⁵	42°	-15.7	-18.8	-18.4	-11	14
	10 ⁻²	50°	-16.7	-20.7	-22.2	---	15

APPENDIX A

Bryn Method of Shading for a Linear Array

C.J. Krieger

In the course of pattern calculations a constant attempt was made to reduce the number of operations to a minimum. The following is the method which was finally adopted.

1. Write the matrix $\{Q\}$ whose elements are the normalized correlation coefficients q_{ih} (Eq. A 2.8 of Appendix 2 of Ref. 2). Form the reciprocal matrix $\{Q^{-1}\}$ with elements r_{ih} .

2. To compensate for a direction θ_c , multiply each r_{ih} by $e^{-j\bar{\theta}_{hc}}$, where

$$\bar{\theta}_{hc} = h \cdot kd \sin \theta_c, \text{ and } k = \frac{2\pi}{\lambda}.$$

3. The filter transfer function or complex shading coefficient is

$$Z_i e^{j\varphi_i} = \sum_h r_{ih} e^{-j\bar{\theta}_{hc}}$$

4. To obtain the response of each filter to sound arriving from direction θ , multiply each filter function $Z_i e^{j\varphi_i}$ by $e^{j\bar{\theta}_i}$, where $\bar{\theta}_i = i kd \sin \theta$.

5. The directivity function $R(\theta, \theta_c) = \sum_i Z_i e^{j\varphi_i} \cdot e^{j\bar{\theta}_i}$

Example:

A five-element linear array with $\lambda/4$ element spacing. System noise to ambient noise ratio 10^{-5} .

1. The $\{q\}$ and $\{q^{-1}\}$ matrices:

$$\{q\} = \begin{Bmatrix} 1.0 & .6366 & 0 & -.2122 & 0 \\ .6366 & 1.0 & .6366 & 0 & -.2122 \\ 0 & .6366 & 1.0 & .6366 & 0 \\ -.2122 & 0 & .6366 & 1.0 & .6366 \\ 0 & -.2122 & 0 & .6366 & 1.0 \end{Bmatrix}$$

$$\{q^{-1}\} = \begin{Bmatrix} +11.94 & -24.27 & +28.97 & -21.24 & +8.37 \\ -24.27 & +55.41 & -68.27 & +51.83 & -21.24 \\ +28.97 & -68.27 & +87.93 & -68.27 & +28.97 \\ -21.24 & +51.83 & -68.27 & +55.41 & -24.27 \\ +8.37 & -21.24 & +28.97 & -24.27 & +11.94 \end{Bmatrix}$$

2. To compensate for $\theta_c = 32.25^\circ$; $\bar{\theta}_{hc} = h \cdot 48.02^\circ$

	$i = -2$	-1	0	$+1$	$+2$
$h = -2$	$11.94 e^{j96.05}$	$-24.27 e^{j96.05}$	$+28.97 e^{j96.05}$	$-21.24 e^{j96.05}$	$+8.37 e^{j96.05}$
-1	$-24.27 e^{j48.02}$	$+55.41 e^{j48.02}$	$-68.27 e^{j48.02}$	$+51.83 e^{j48.02}$	$-21.24 e^{j48.02}$
0	$+28.97 e^{j0}$	$-68.27 e^{j0}$	$+87.93 e^{j0}$	$-68.27 e^{j0}$	$+28.97 e^{j0}$
$+1$	$-21.24 e^{-j48.02}$	$+51.83 e^{-j48.02}$	$-68.27 e^{-j48.02}$	$+55.27 e^{-j48.02}$	$-24.27 e^{-j48.02}$
$+2$	$+8.37 e^{-j96.04}$	$-21.24 e^{-j96.05}$	$+28.97 e^{-j96.05}$	$-24.97 e^{-j96.05}$	$+11.94 e^{-j96.05}$

3. Filter Transfer Functions.

z_{-2}	z_{-1}	z_0	z_1	z_2
$3.84 e^{j160.2^\circ}$	$8.27 e^{-j2.44^\circ}$	$9.51 e^{j180^\circ}$	$8.27 e^{j2.44^\circ}$	$3.84 e^{-j160.2^\circ}$

4. For sound arriving from $\theta = 90^\circ$; $\bar{\theta}_1 = 190^\circ$

$i = -2$	-1	0	$+1$	$+2$
$3.84 e^{j160.2^\circ}$	$8.27 e^{-j2.44}$	$9.51 e^{j180^\circ}$	$8.27 e^{j2.44}$	$3.84 e^{-j160.2}$
$\cdot e^{-j180}$	$\cdot e^{-j90^\circ}$	$\cdot e^{j0}$	$\cdot e^{j90^\circ}$	$\cdot e^{j180^\circ}$

5. $R(90^\circ, 32.25^\circ) = -2.99$ (units)

Repeat for other values of θ .

Acknowledgment

Various helpful discussions with Burwell B. Goode are gratefully acknowledged. He also made available to the author computer results which were used in the preparation of this memorandum.

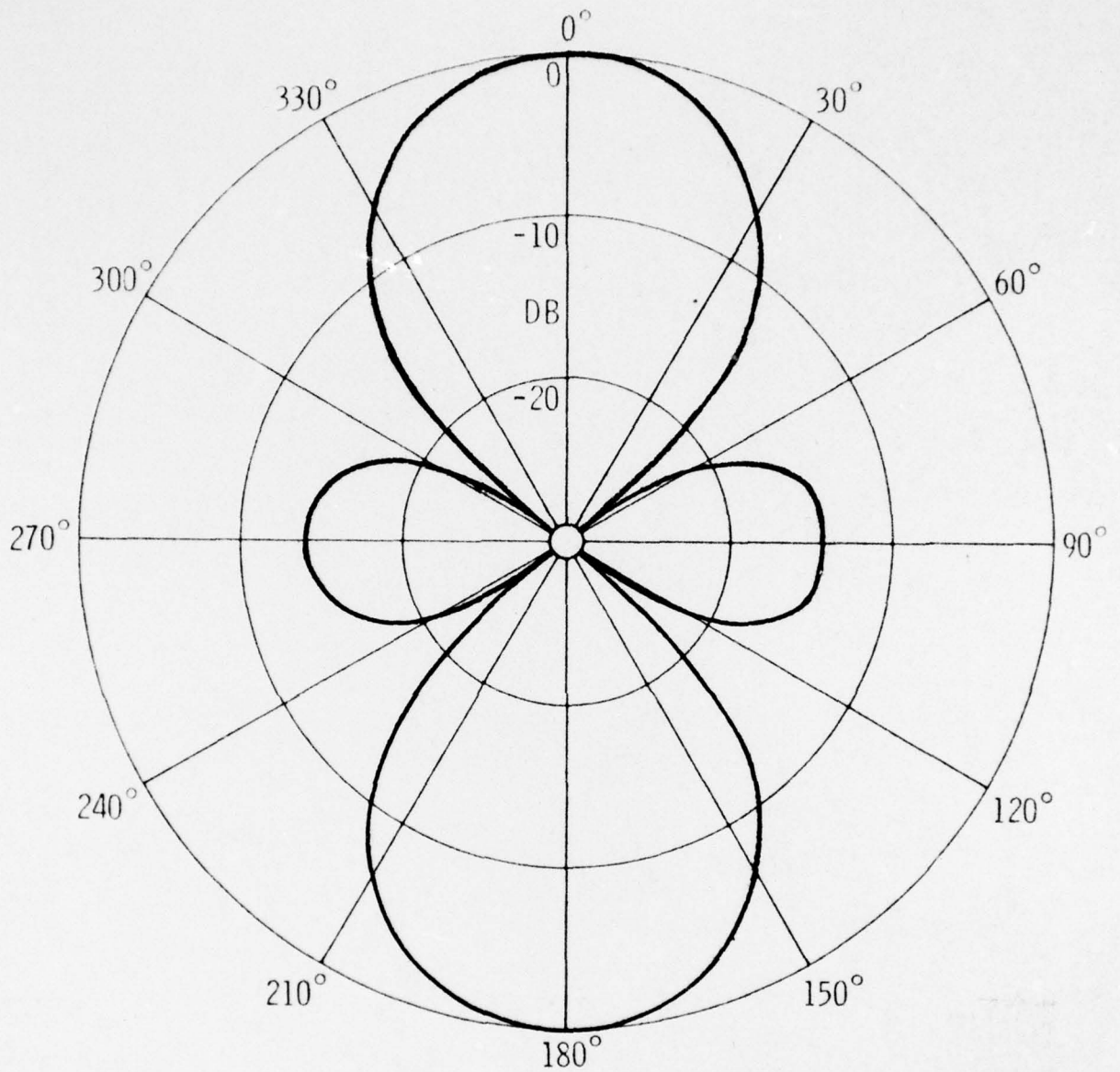

Figure 1. 5-Element Linear Array. $\lambda/4$ Spacing. $\theta_c = 0^\circ$.
 Unshaded. Beam Width 42° . Highest Minor Lobe
 Level -14.1 db.

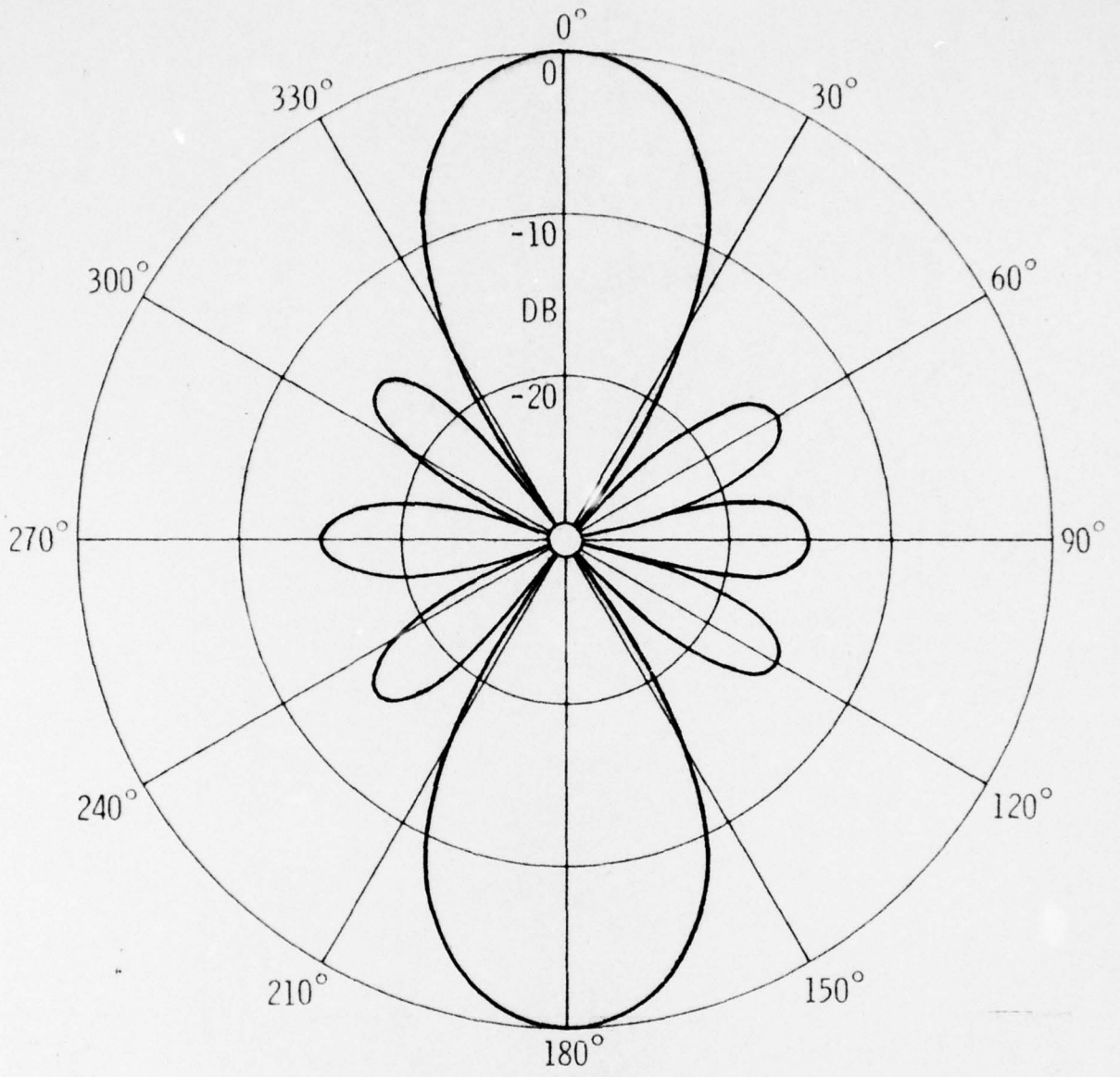

Figure 2. 5-Element Linear Array. $\lambda/4$ Spacing. $\theta_c = 0^\circ$.
 Pritchard Shading. Beam Width 30° . Highest Minor
 Lobe Level -15 db.

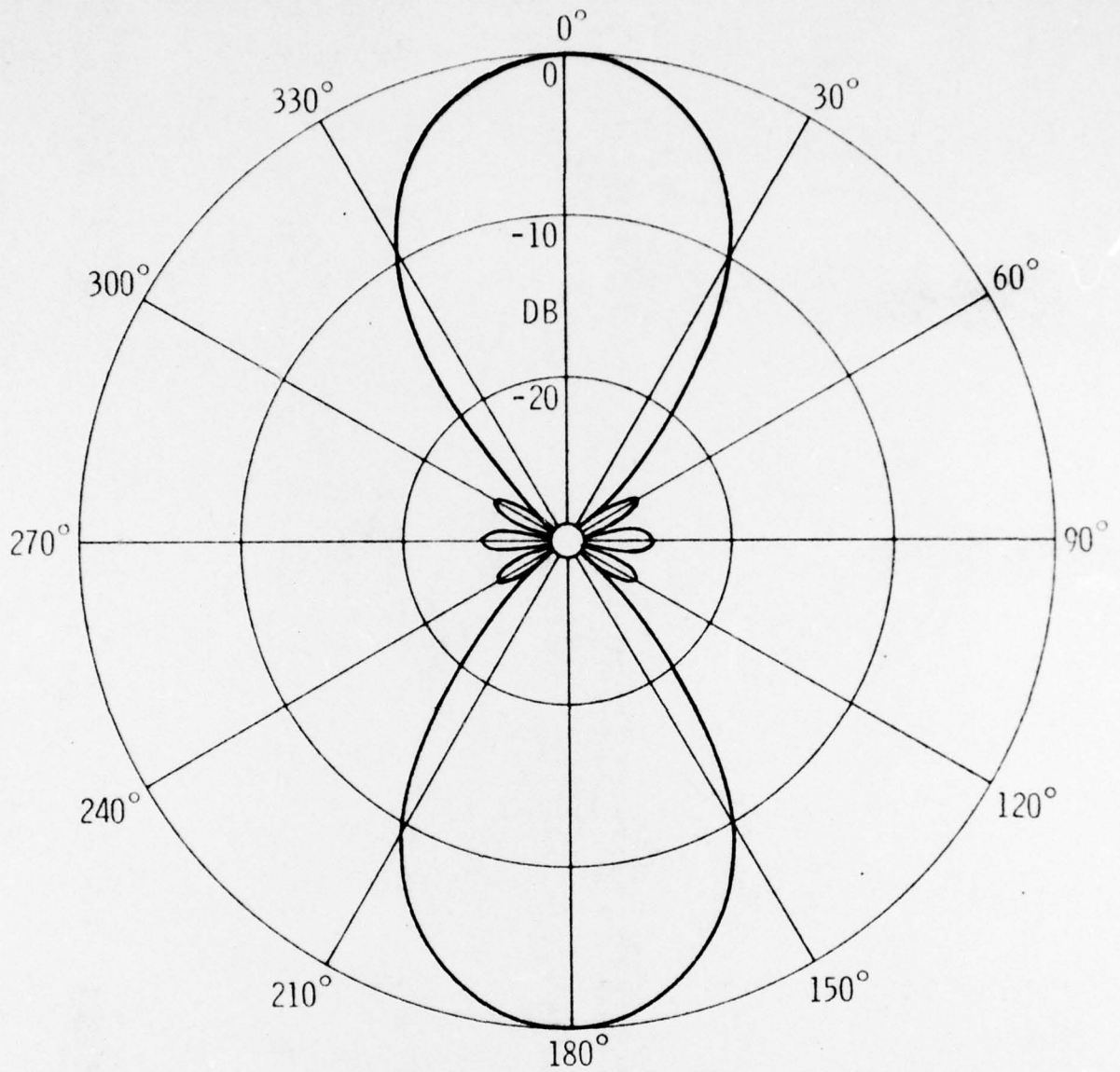

Figure 3. 5-Element Linear Array. $\lambda/4$ Spacing. $\theta_c = 0^\circ$.
 Pritchard Shading. Beam Width 34° . Highest Minor
 Lobe -24.6 db.

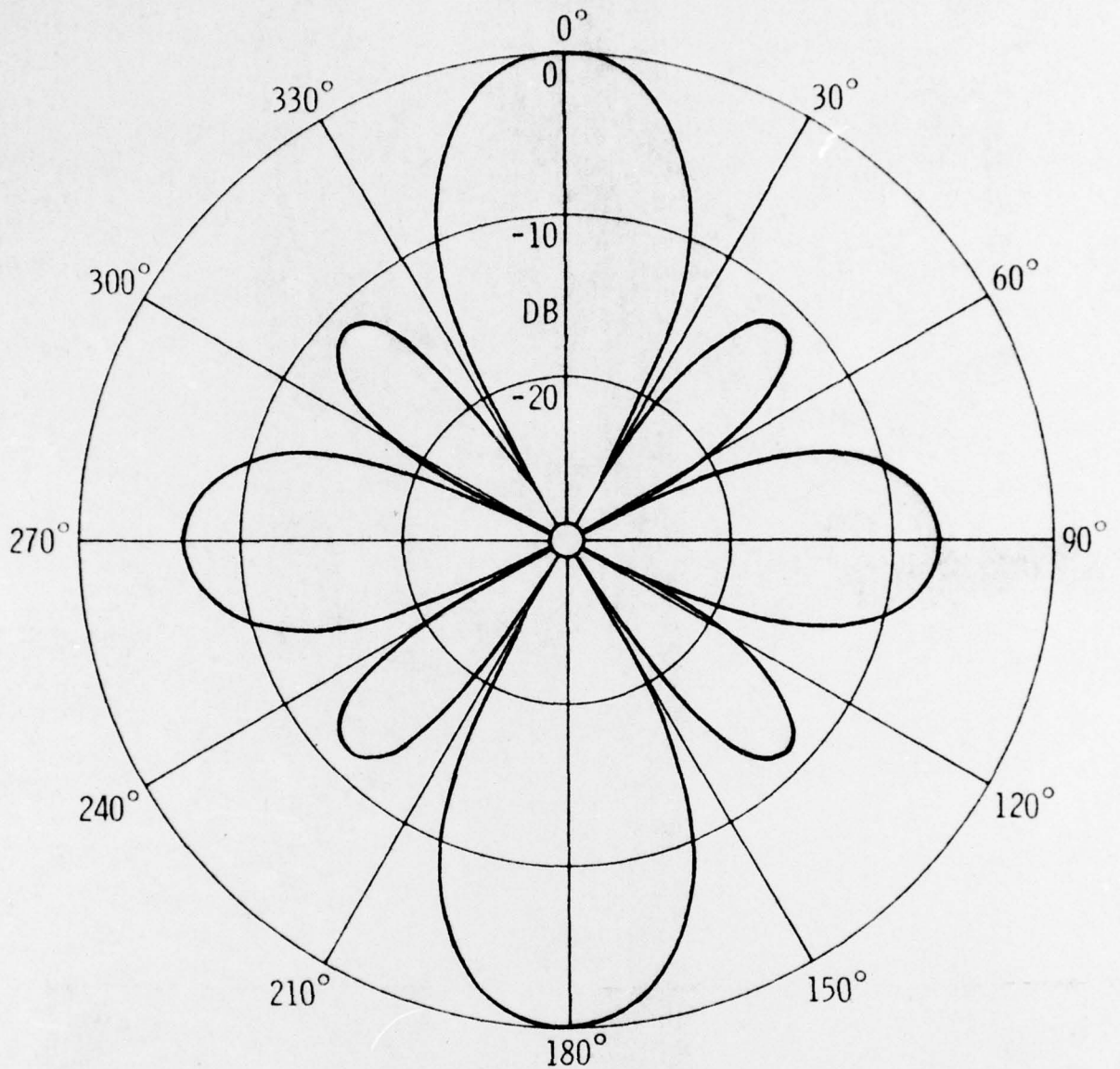

Figure 4. 5-Element Linear Array. $\lambda/4$ Spacing. $\theta_c = 0^\circ$. Bryn Shading. Noise Ratio 10^5 . Beam Width 28° . Highest Minor Lobe Level -6.8 db.

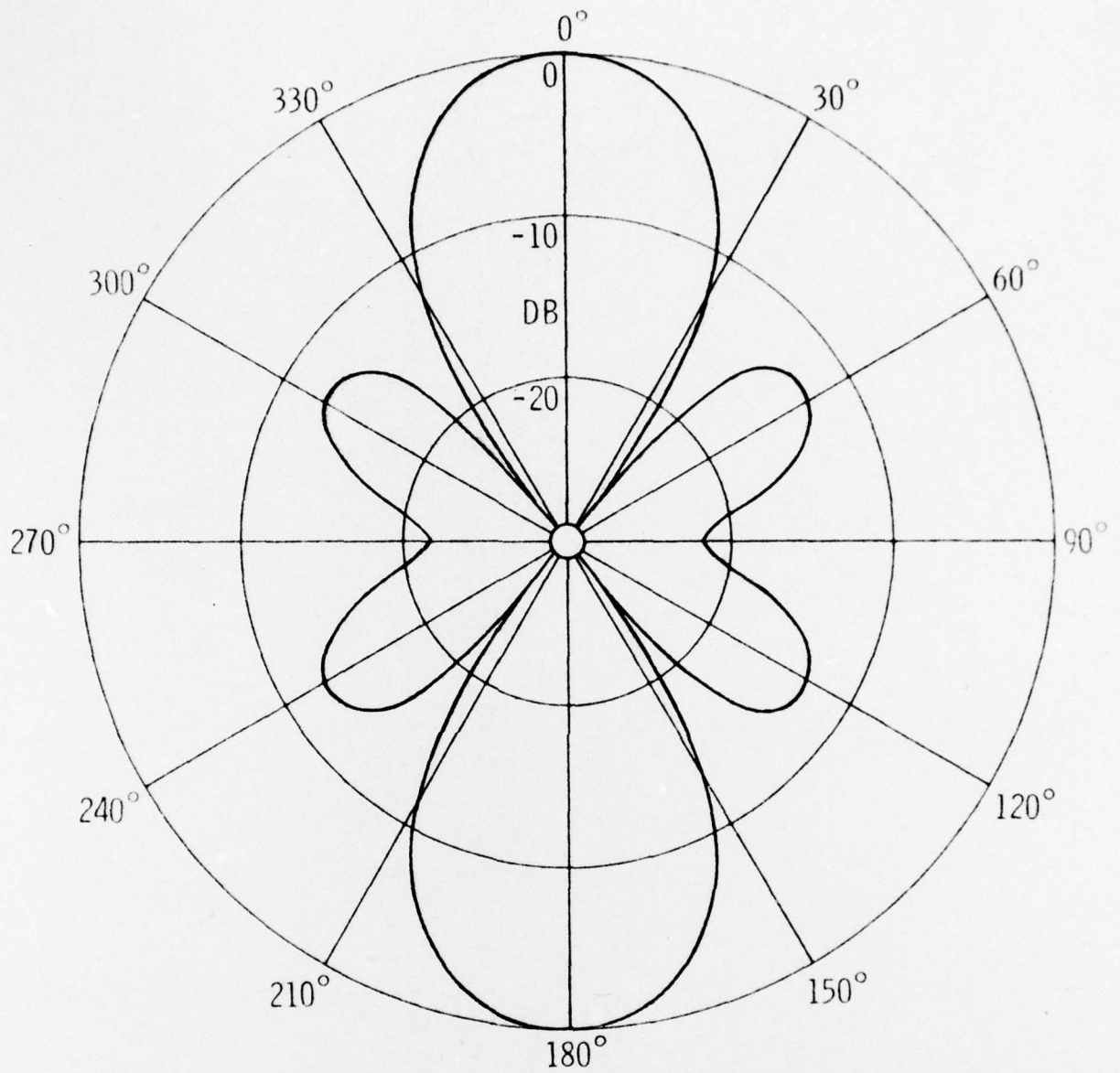

Figure 5. 5-Element Linear Array. $\lambda/4$ Spacing. $\theta_c = 0^\circ$. Bryn Shading. Noise Ratio 10^{-2} . Beam Width 32° . Highest Minor Lobe Level -13 db.

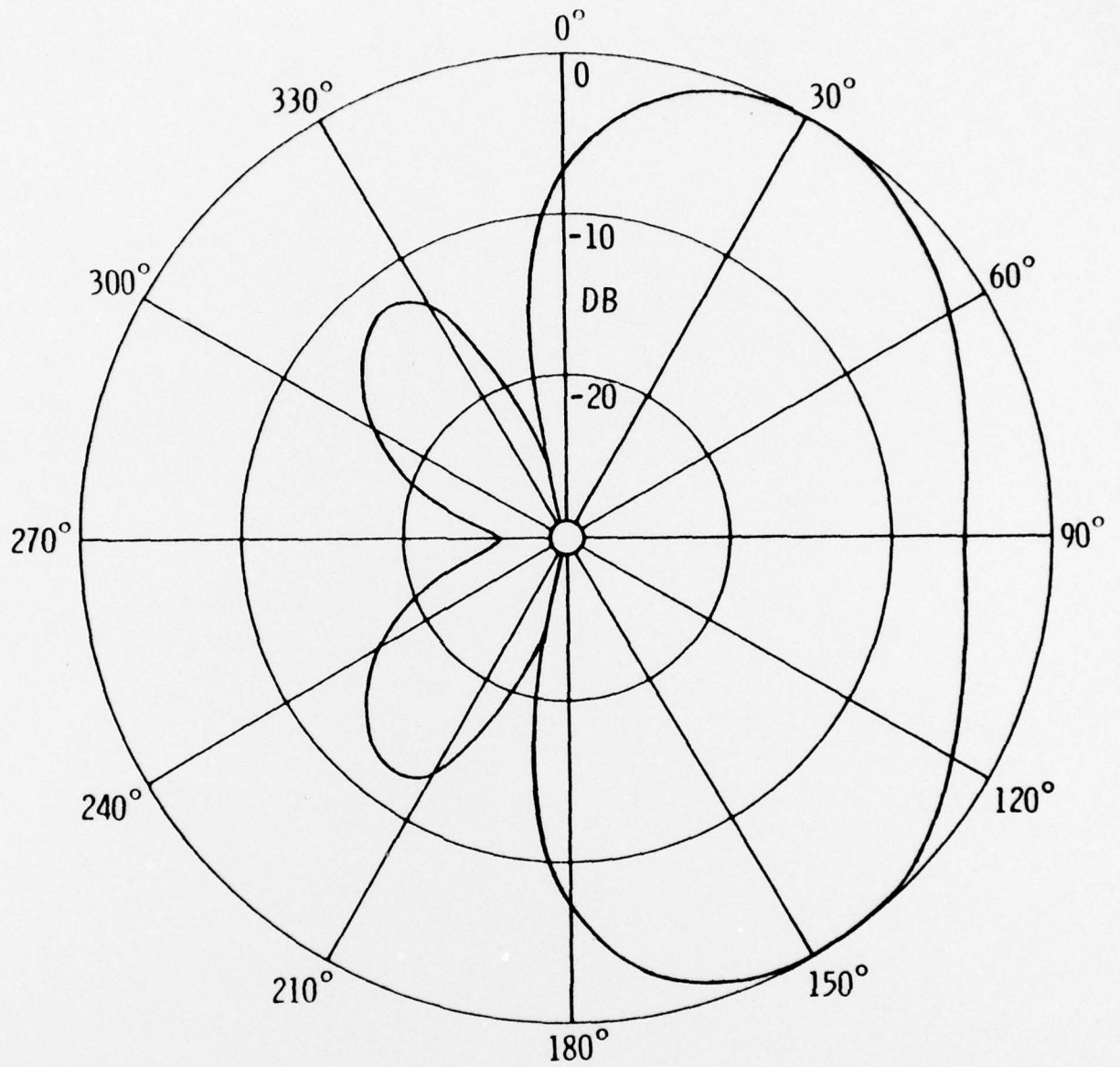

Figure 6. 5-Element Linear Array. $\lambda/4$ Spacing. $\theta_c = 32^\circ 25'$. Unshaded. Beam Width 54° . Highest Minor Lobe Level -12 db.

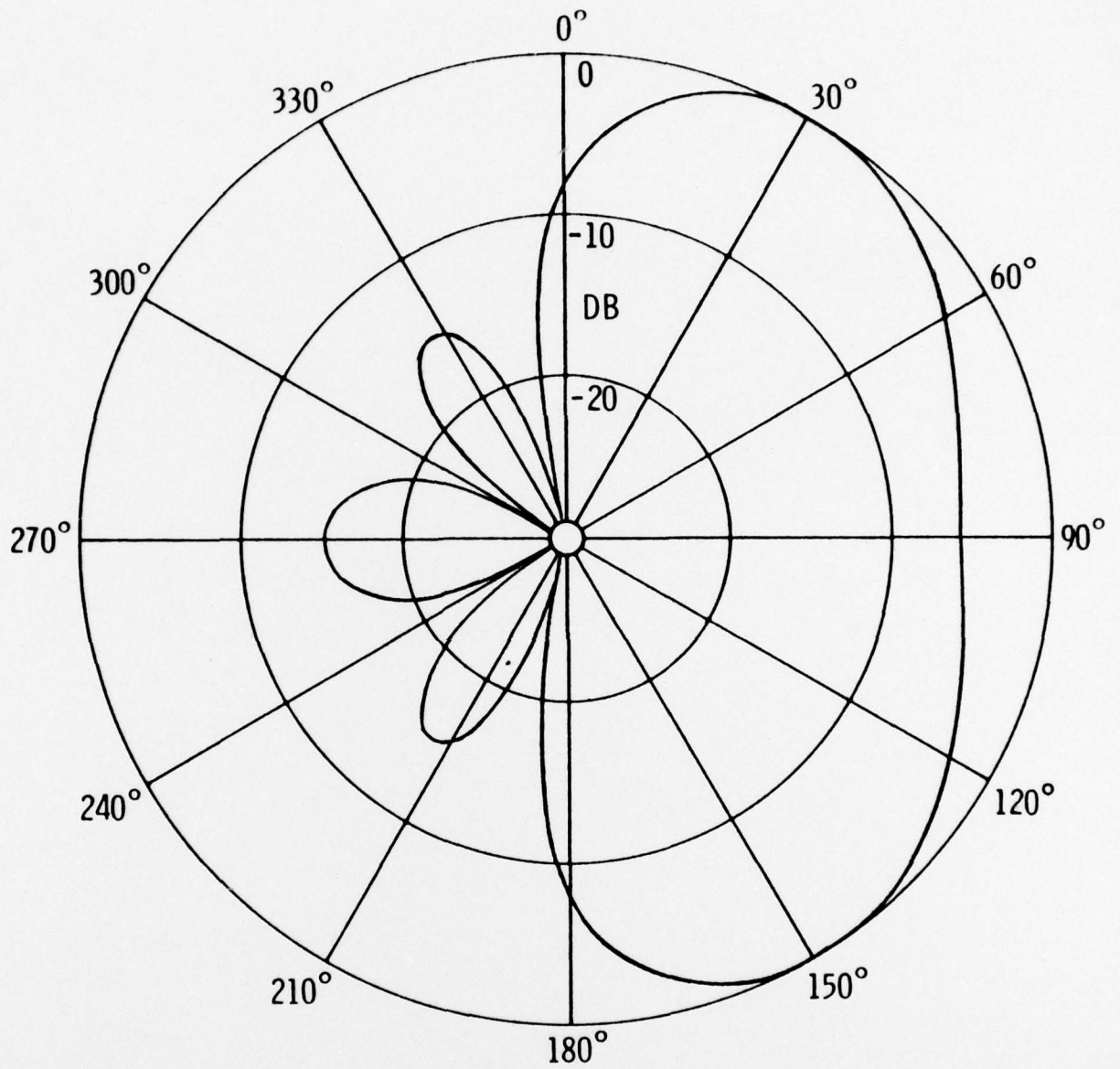
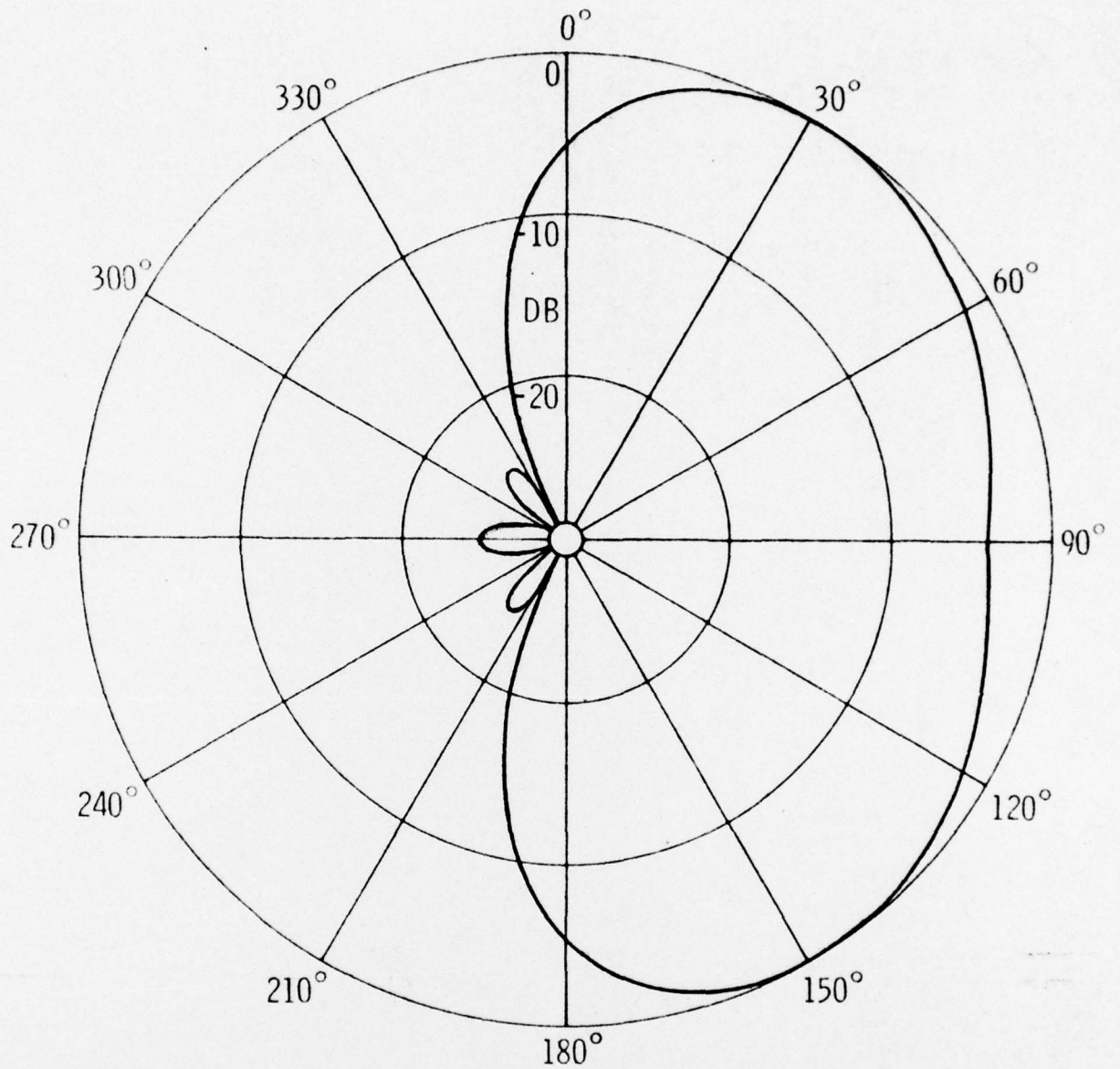

Figure 7. 5-Element Linear Array. $\lambda/4$ Spacing. $\theta_c = 32^\circ 25'$.
 Pritchard Shading. Beam Width 53° . Highest Minor
 Lobe Level -15 db.



**Figure 8. 5-Element Linear Array. $\lambda/4$ Spacing. $\theta_c = 32^\circ 25'$.
 Pritchard Shading. Beam Width 64° . Highest Minor
 Lobe Level -24.6 db.**

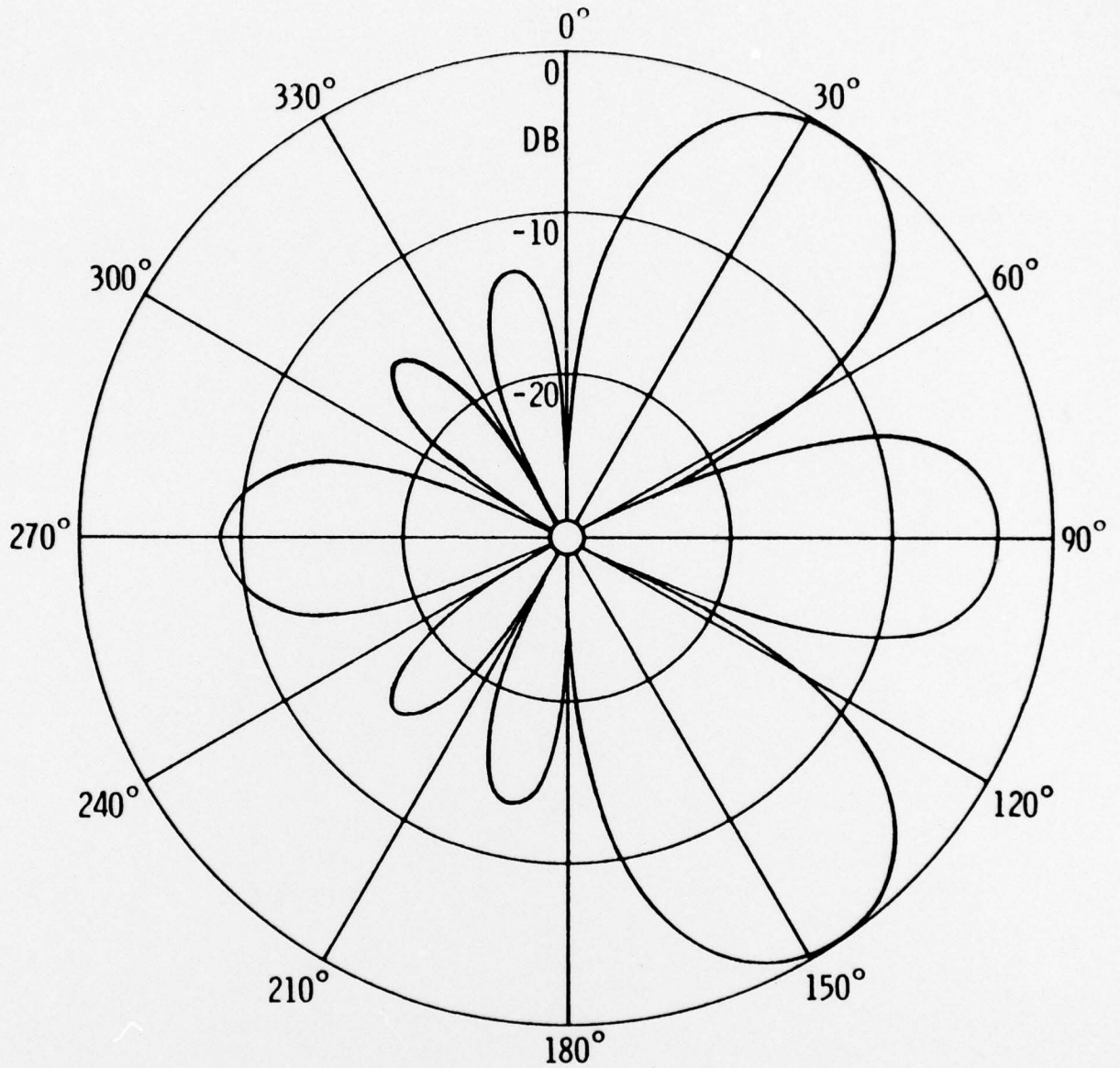
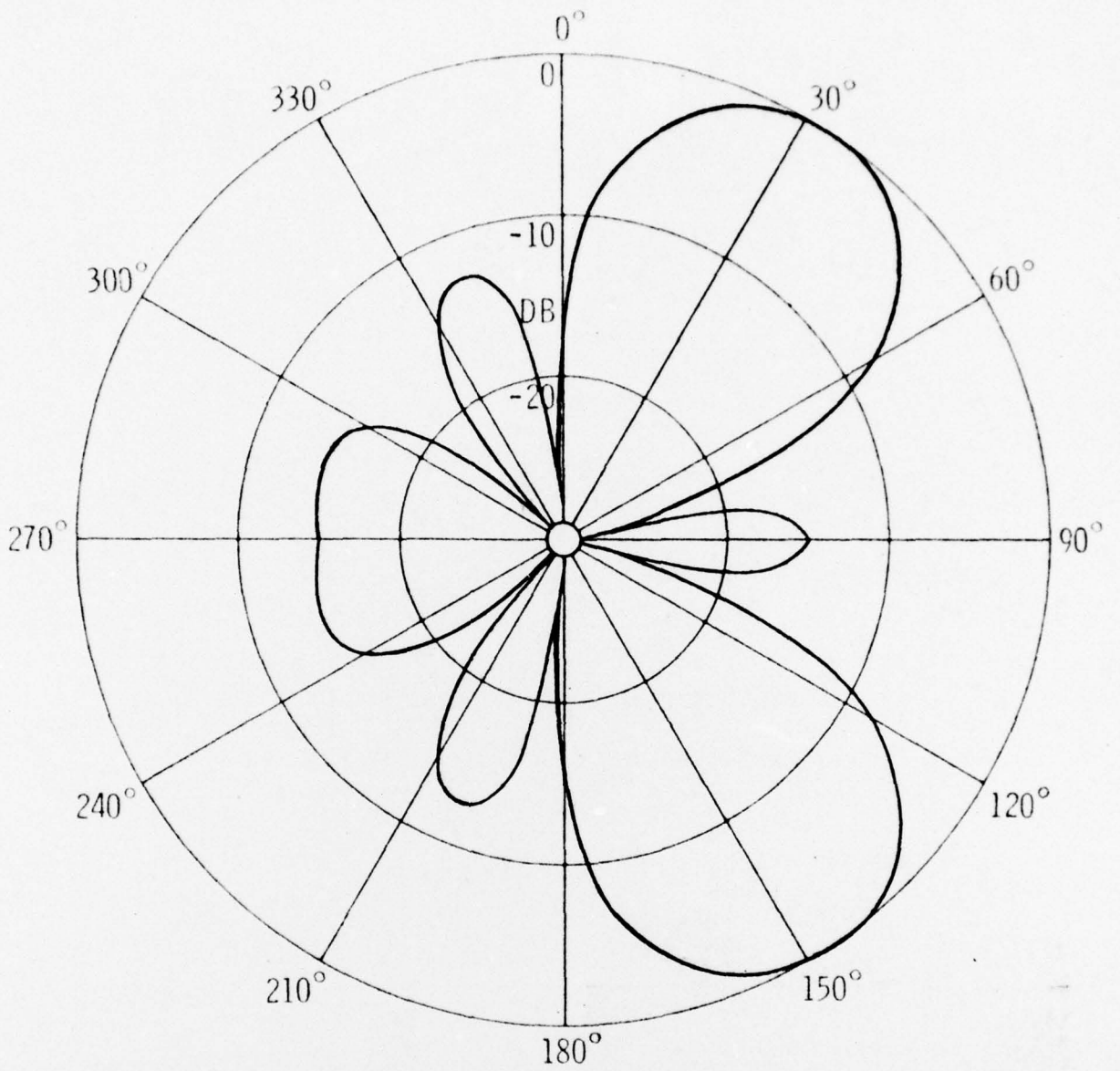

Figure 9. 5-Element Linear Array. $\lambda/4$ Spacing. $\theta_c = 32.25^\circ$.
 Bryn Shading. Noise Ratio 10^5 . Beam Width 29° .
 Highest Minor Lobe Level -3.6 db.



**Figure 10. 5-Element Linear Array. $\lambda/4$ Spacing. $\theta_c = 32:25$.
 Bryn Shading. Noise Ratio 10^3 . Beam Width 35° .
 Highest Minor Lobe Level -12.6 db.**

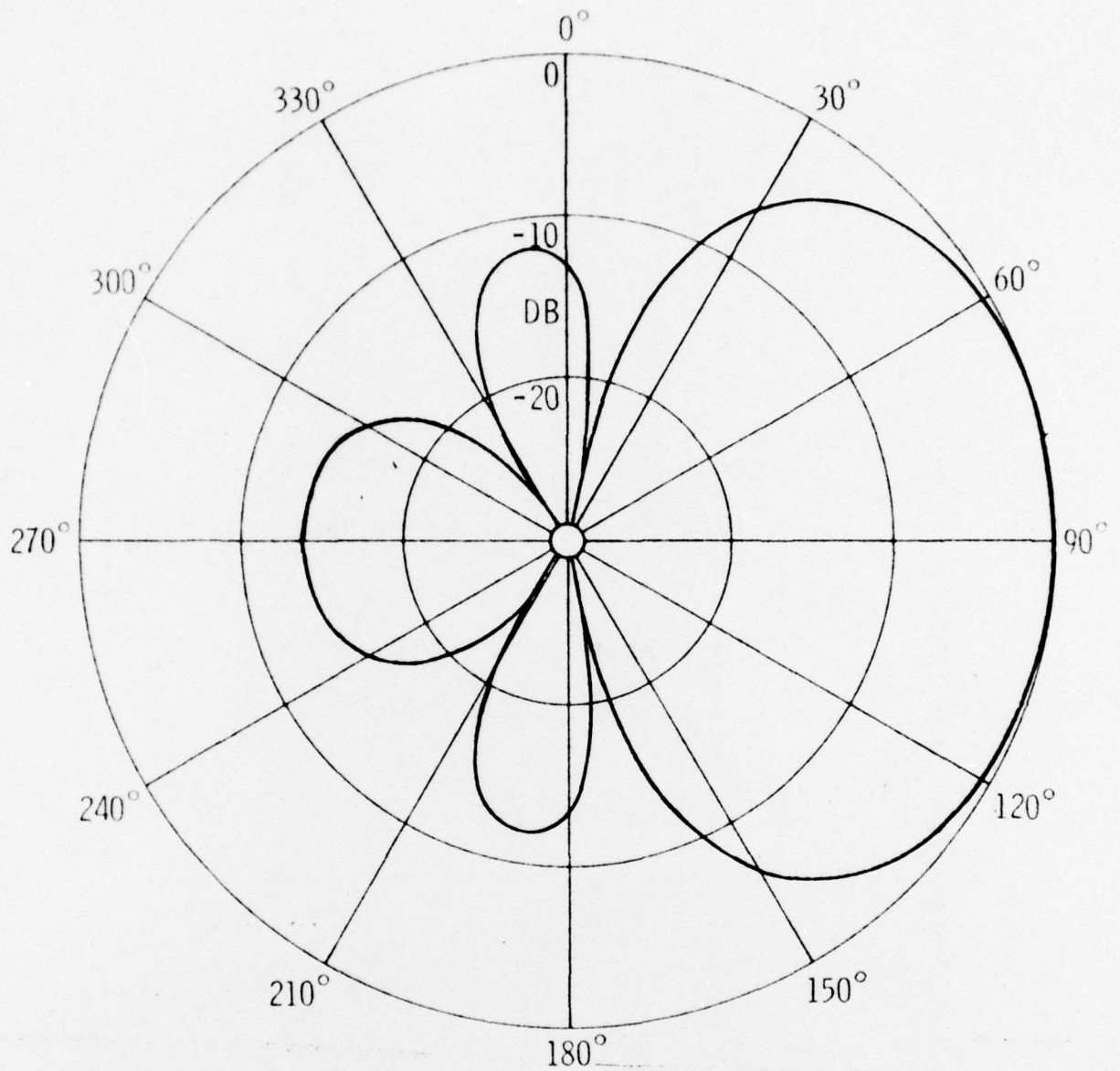

Figure 11. 5-Element Linear Array. $\lambda/4$ Spacing. $\theta_c = 90^\circ$. Unshaded. Beam Width 100° . Highest Minor Lobe Level -11.8 db.

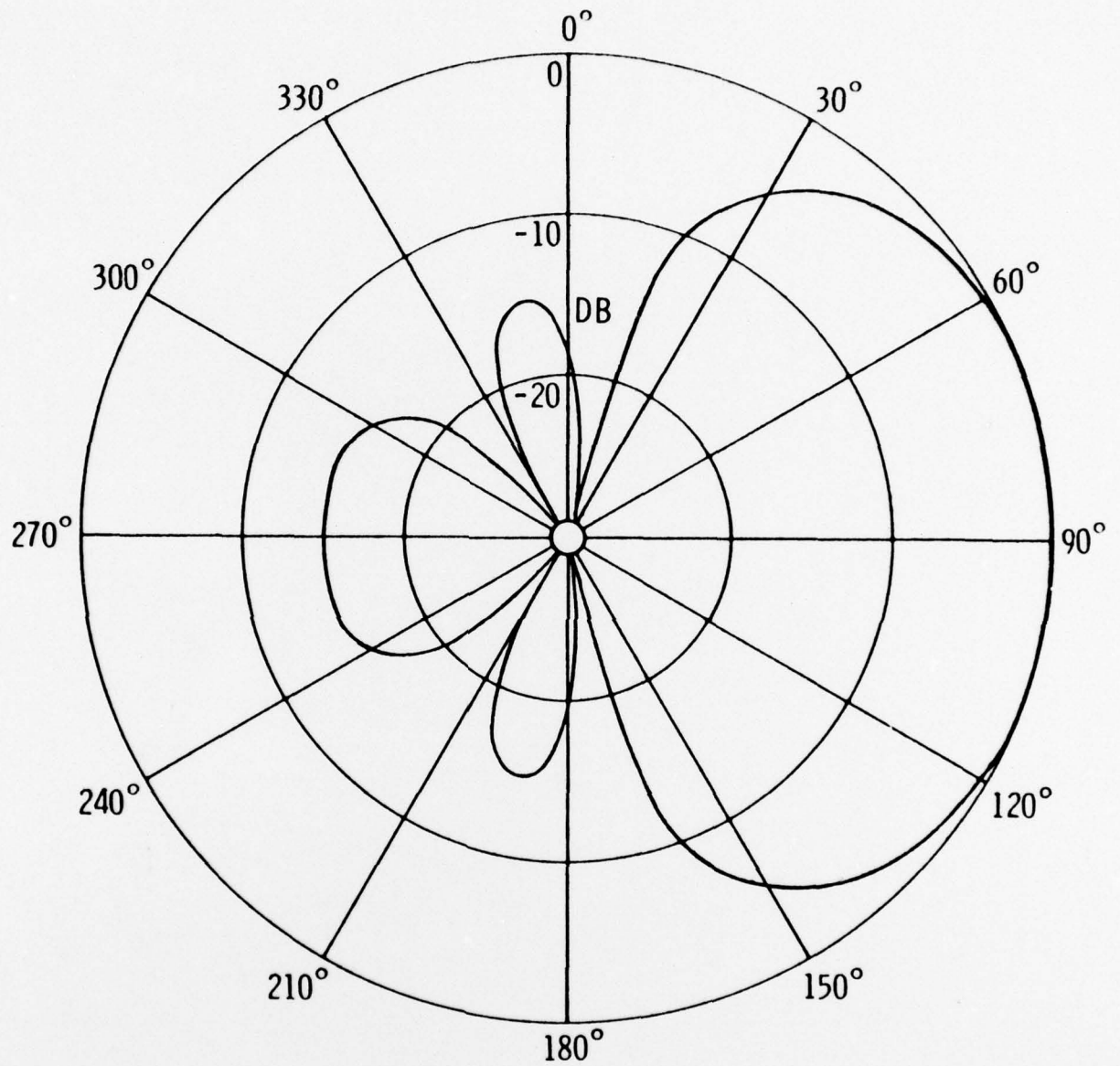

Figure 12. 5-Element Linear Array. $\lambda/4$ Spacing. $\theta_c = 90^\circ$.
 Pritchard Shading. Beam Width 103° . Highest
 Minor Lobe Level -15 db.

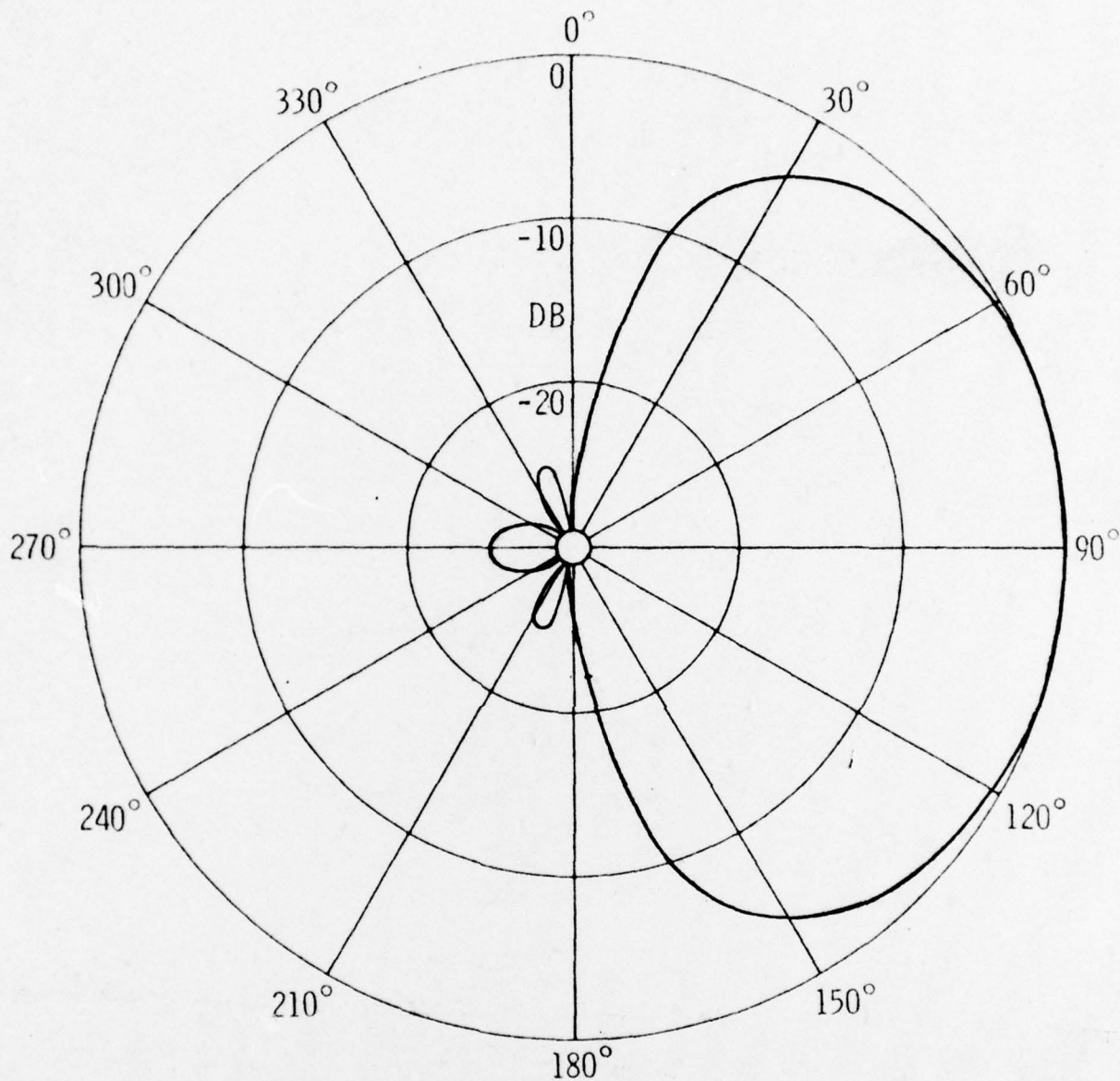

Figure 13. 5-Element Linear Array. $\lambda/4$ Spacing. $\theta_c = 90^\circ$. Pritchard Shading. Beam Width 112° . Highest Minor Lobe Level -24.6 db.

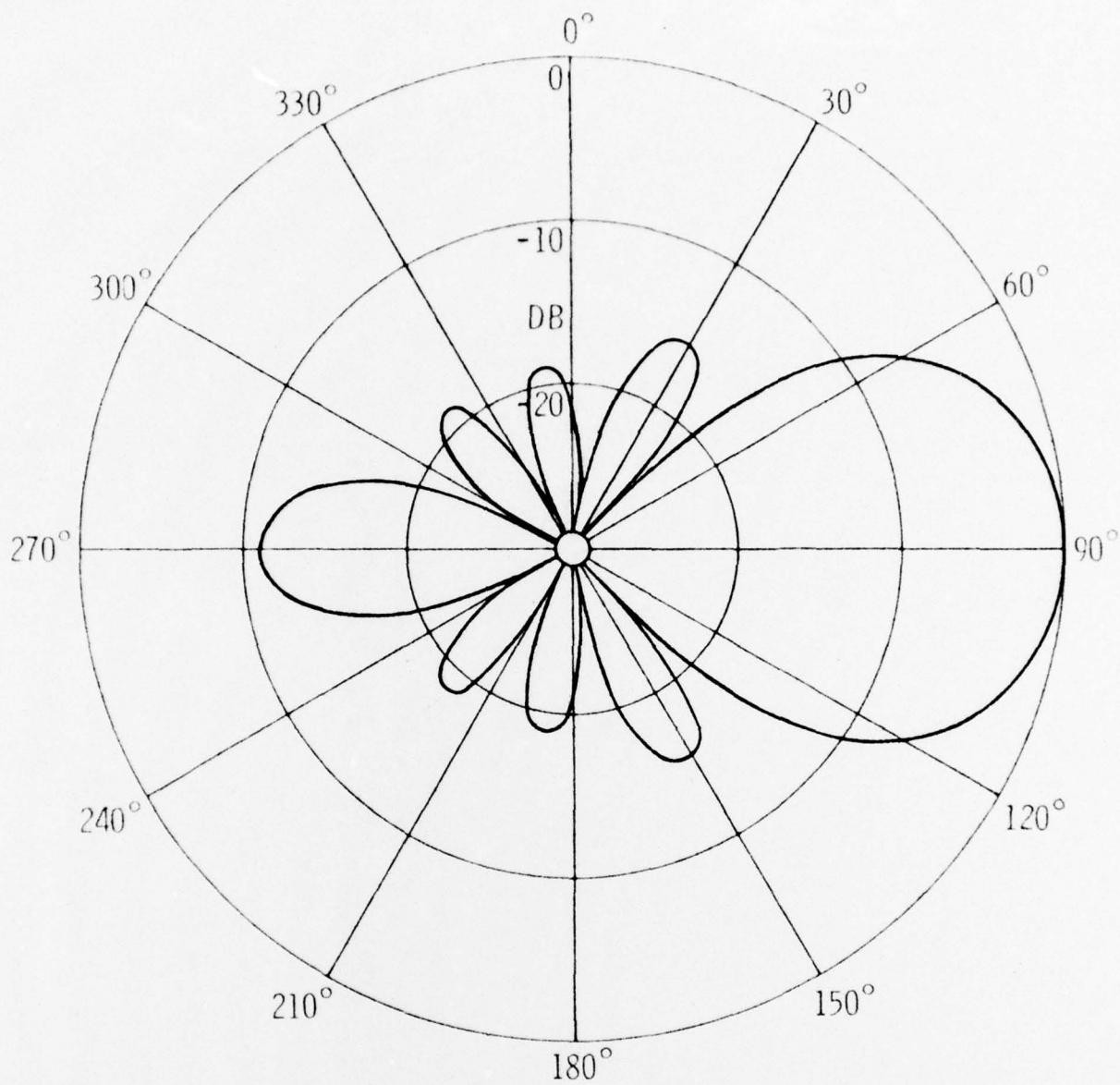
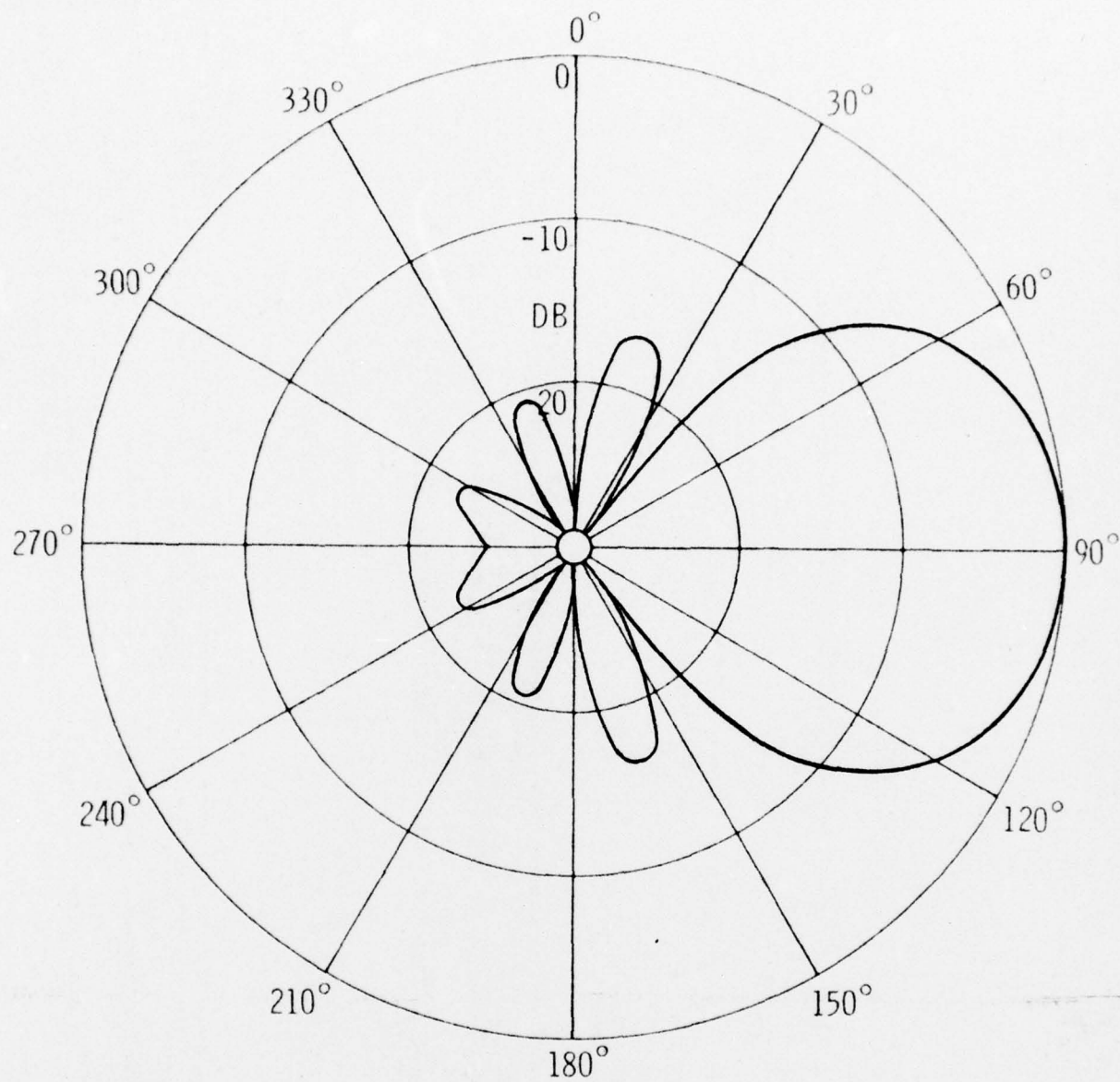

Figure 14. 5-Element Linear Array. $\lambda/4$ Spacing. $\theta_c = 90^\circ$.
 Bryn Shading. Noise Ratio 10^{-5} . Beam Width 42° .
 Highest Minor Lobe Level -11 db.



**Figure 15. 5-Element Linear Array. $\lambda/4$ Spacing. $\theta_c = 90^\circ$.
 Bryn Shading. Noise Ratio 10^{-2} . Beam Width 50° .
 Highest Minor Lobe Level -16.7 db.**