

AD-A049 837

NAVY ELECTRONICS LAB SAN DIEGO CALIF
CREST FACTOR OF BAND LIMITED PSEUDORANDOM NOISE. (U)
SEP 65 R K BETSWORTH
NEL-TM-849

F/G 17/1

UNCLASSIFIED

NL

| OF |
AD
A049837



END
DATE
FILMED
3 -78
DDC

AD A 049837

AD No. _____
DDC FILE COPY

MOST Project



U. S. NAVY ELECTRONICS LABORATORY, SAN DIEGO, CALIFORNIA - A BUREAU OF SHIPS LABORATORY

This is a working paper giving tentative information about some work in progress at NEL.
If cited in the literature the information is to be identified as tentative and unpublished.

4133
849
Good

9 TECHNICAL MEMORANDUM 14 NEL-
TM-849

6 CREST FACTOR OF BAND LIMITED PSEUDORANDOM NOISE.

11 29 Sept 1965

10 R. K. Betsworth (Code 3150D)

17 SF 001 03 16 (11197)
NEL E11961

16 F00103

12 15p.

NEL/Technical Memorandum 849

DISTRIBUTION STATEMENT A
Approved for public release;
Distribution Unlimited

DDC
RECEIVED
FEB 18 1978
A

849

849

253 550

LB

NEL Technical Memorandum
Number TM-849

29 September 1965

CREST FACTOR OF BAND LIMITED
PSEUDORANDOM NOISE

by

R. K. Betsworth

Code 3150D

U. S. Navy Electronics Laboratory
San Diego, California 92152

ACCESSION for	
NTIS	White Section <input checked="" type="checkbox"/>
DDC	Buff Section <input type="checkbox"/>
UNANNOUNCED	<input type="checkbox"/>
JUSTIFICATION	
<i>added on file</i>	
BY	
DISTRIBUTION/AVAILABILITY CODES	
Dist.	AVAIL. and/or SPECIAL
A	

INTRODUCTION

→ This memorandum describes briefly laboratory tests that were conducted by the author to determine sonar source level limitations due to amplitude modulation when using pseudorandom noise transmissions. These tests were by no means comprehensive or exhaustive, but did suffice to demonstrate the degree of loss that might be expected when this type of signal is utilized in a peak power limited system. The numerical results obtained from these tests appear sufficient to answer some of the initial questions which have been raised concerning this degradation in power. This memorandum has been prepared to provide engineering information that may prove useful in this form to others at NEL and perhaps a few persons or activities outside of NEL. This memorandum should not be construed as a technical report as its primary function is to present for engineering purposes information concerning only a portion of the work associated with pseudorandom noise signal studies. This work was performed under NEL Problem Number E11961. ↗

BACKGROUND

Pseudorandom noise (PN) transmissions consist of pulses wherein the carrier frequency, amplitude and phase are varied in a discontinuous but predetermined fashion. Such pulses can be generated by a digital shift register configured (Figure 1) to produce pseudorandom sequences of ones and zeroes. For an n-stage register, the sequence length will equal $2^n - 1$ bits before repeating. The spectrum envelope, Figure 2, of such a device is of the $\sin x/x$ form where the spectrum is composed of individual lines separated in frequency by $F/(2^n - 1)$, where F is the frequency of the clock driving the shift register. If the output of the generator (PNG) is bandpass filtered to W cps in the flat region of the spectrum at frequencies below $F/2$, the output signal appears as band limited noise having amplitude modulation. Because of this modulation, the effective power of the transmitted signal is less relative to that of a sinusoidal signal or linear frequency modulated signal having the same peak amplitude. If the PNG is driven at a lower frequency and low pass filtered to W cps to transmit a major portion of the spectrum, the amplitude modulation should be decreased. For example, if the entire spectrum were transmitted, there would be no amplitude modulation because the PNG time function could be reproduced with fidelity.

LABORATORY TESTS

The following tests were conducted to measure the crest factor of band limited PN as a function of bandwidth and PNG drive frequency. The two different test setups used are shown in Figures 3 and 4. In both test setups, the PNG was a 15-stage shift register encoder constructed

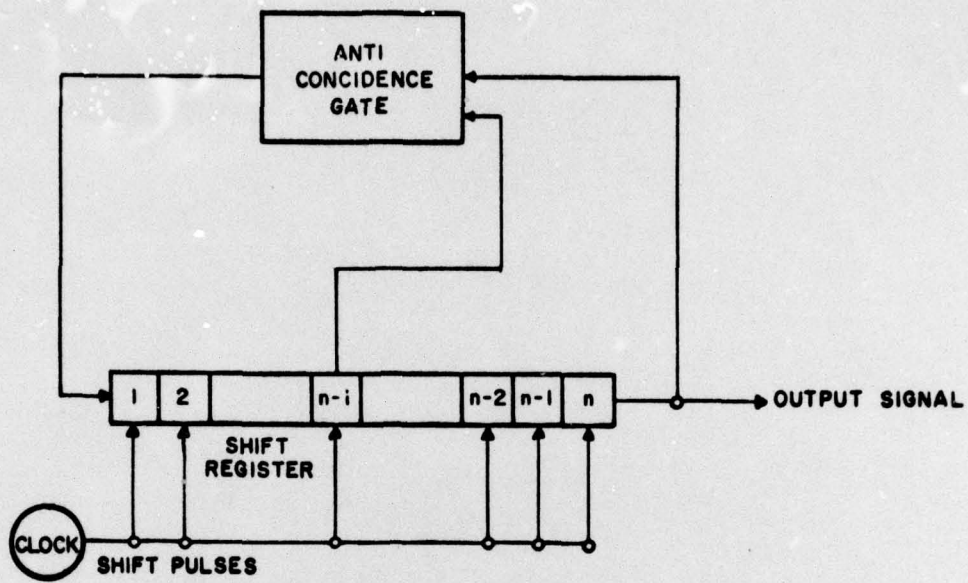

Figure 1. Block Diagram of Pseudorandom Noise Generator

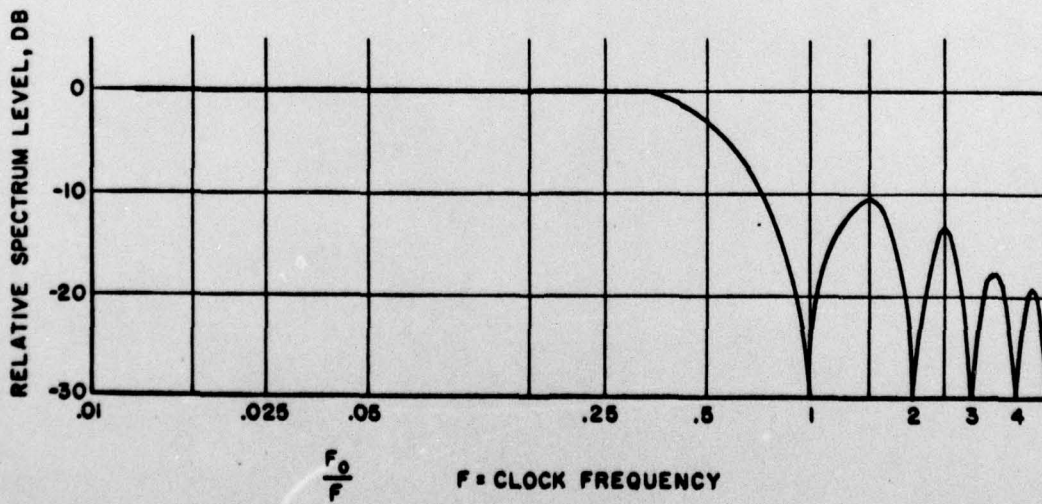

Figure 2. Frequency Distribution of Output of Pseudorandom Noise Generator

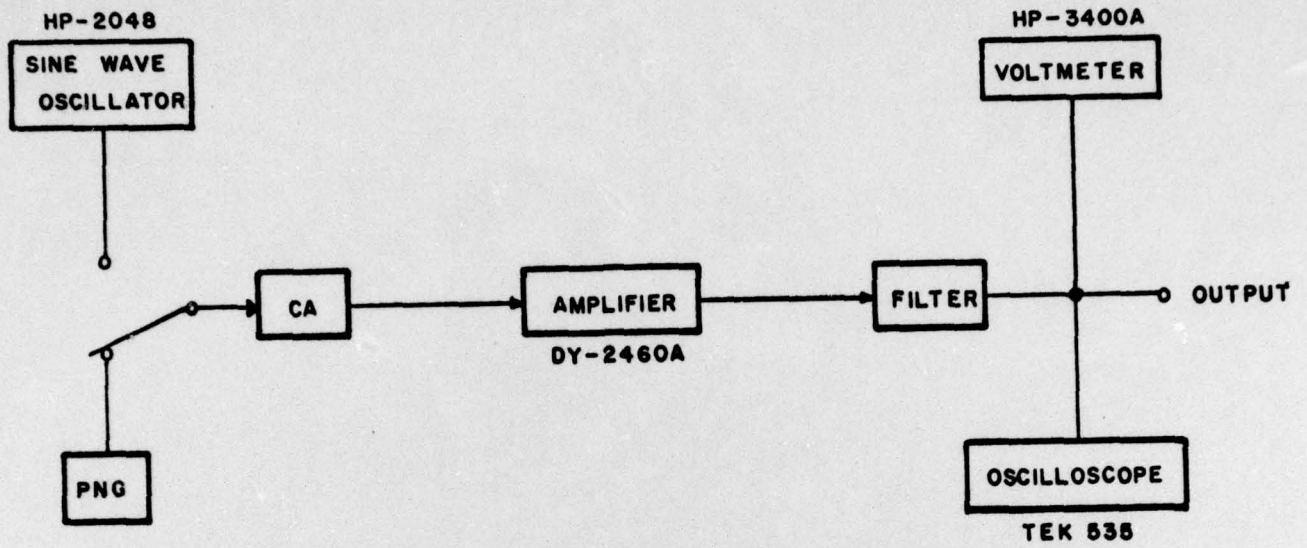

Figure 3. Test Setup No.1

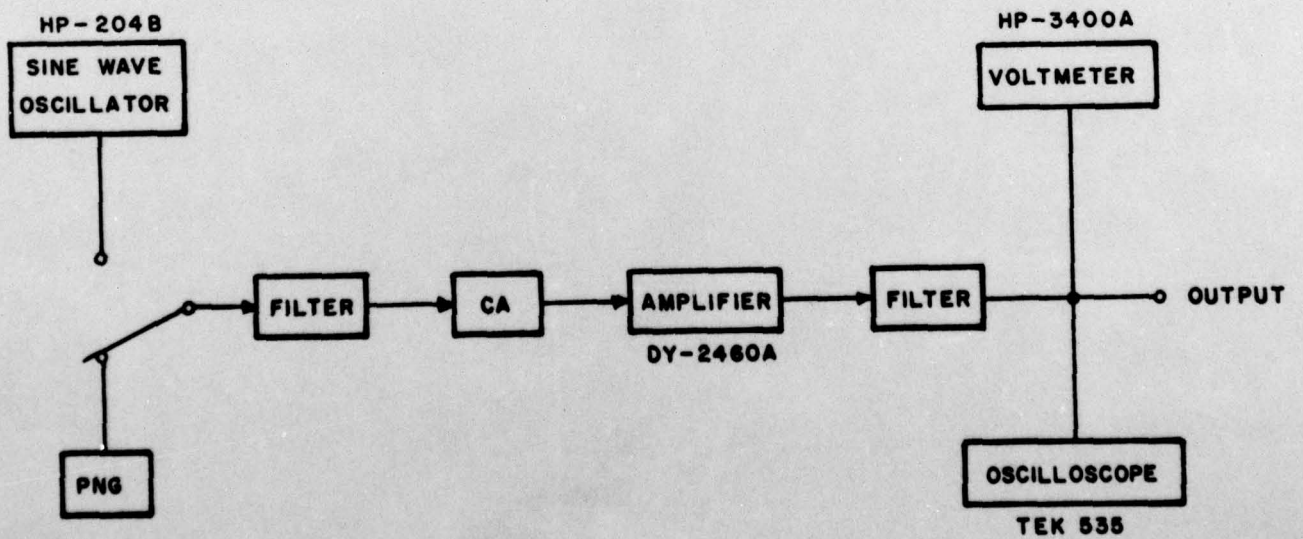

Figure 4. Test Setup No.2

using Digital Equipment Corporation logic cards. The clipper amplifier (CA) was a standard Computer Control Corporation DELTIC card. Donald C. Harder filters, type numbers 90655 and 90652, were used to band limit the PN spectrum to 30 cps and 100 cps respectively, centered at 1500 cps. An NEL low pass filter, type number 5129, was used to band limit the PN spectrum to 100 cps centered at 50 cps. The filter characteristics are shown in Figures 5 through 7. The true rms voltage of the output signals were measured with a Hewlett-Packard 3400A voltmeter and the peak voltages were read on a Tektronix oscilloscope. The results are expressed as a crest factor ratio. The crest factor ratio is a measure of the effective power of a sinusoidal signal relative to that of a PN signal having the same peak amplitude. This ratio was calculated using the following equation:

$$\text{Crest Factor Ratio} = \frac{\text{Crest Factor of Sinusoidal Signal}}{\text{Crest Factor of PN Signal}}$$

$$\text{Crest Factor Ratio} = \frac{\frac{(V_{\text{sin}})_{\text{pk}}}{(V_{\text{sin}})_{\text{rms}}}}{\frac{(V_{\text{pn}})_{\text{pk}}}{(V_{\text{pn}})_{\text{rms}}}} = \frac{\left[\frac{V_{\text{sin}}}{V_{\text{pn}}} \right]_{\text{pk}}}{\left[\frac{V_{\text{sin}}}{V_{\text{pn}}} \right]_{\text{rms}}}$$

These ratios are expressed in decibels in Figure 8.

Test setup number 1 was implemented to measure the crest factor ratio for a clip-filter condition. In this configuration, a constant amplitude signal provides the drive to the filter. The output of the filter, which corresponds to the transmitted (or received) signal, was measured and the crest factor ratio was calculated.

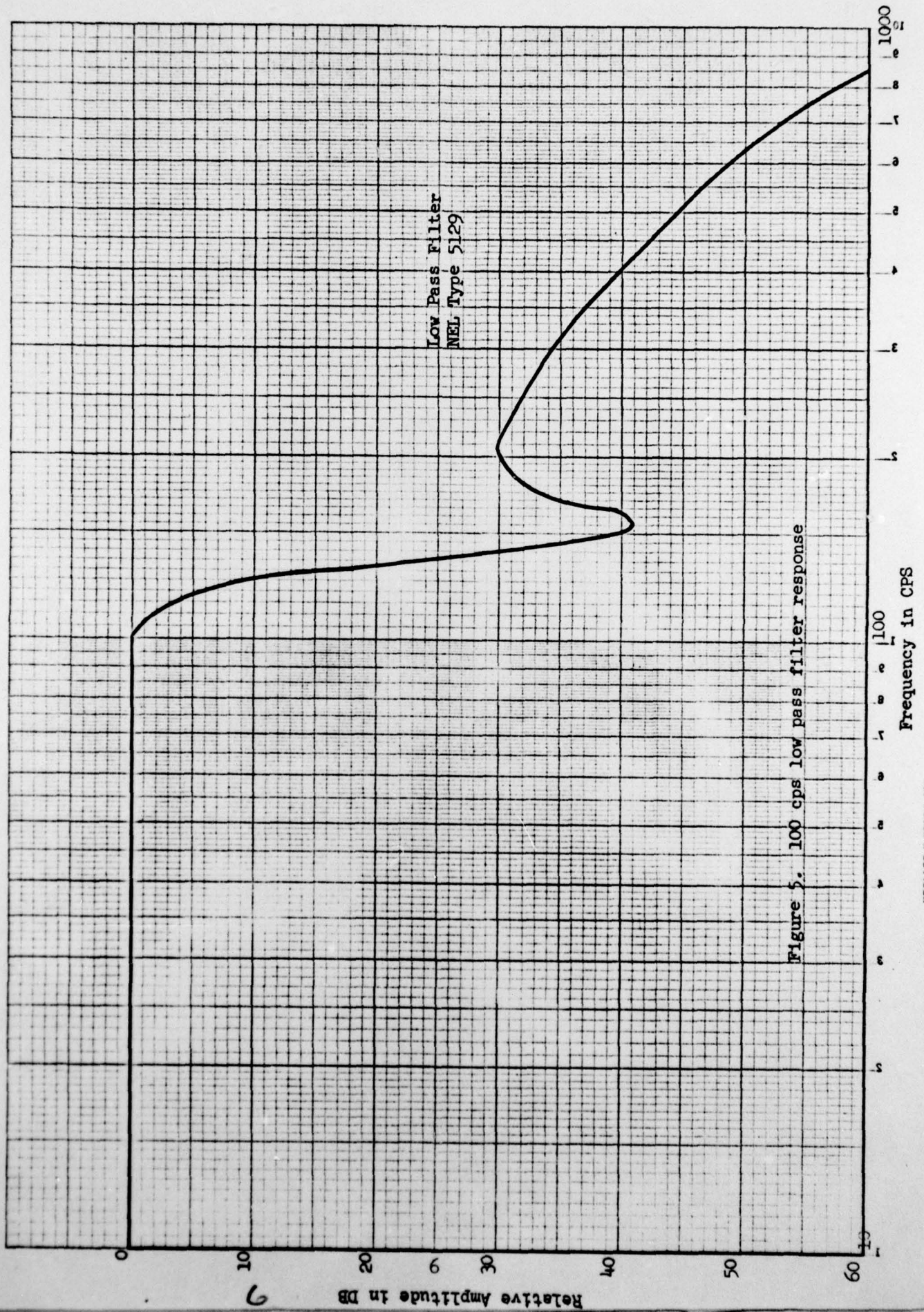

Figure 5. 100 cps low pass filter response

Frequency in CPS

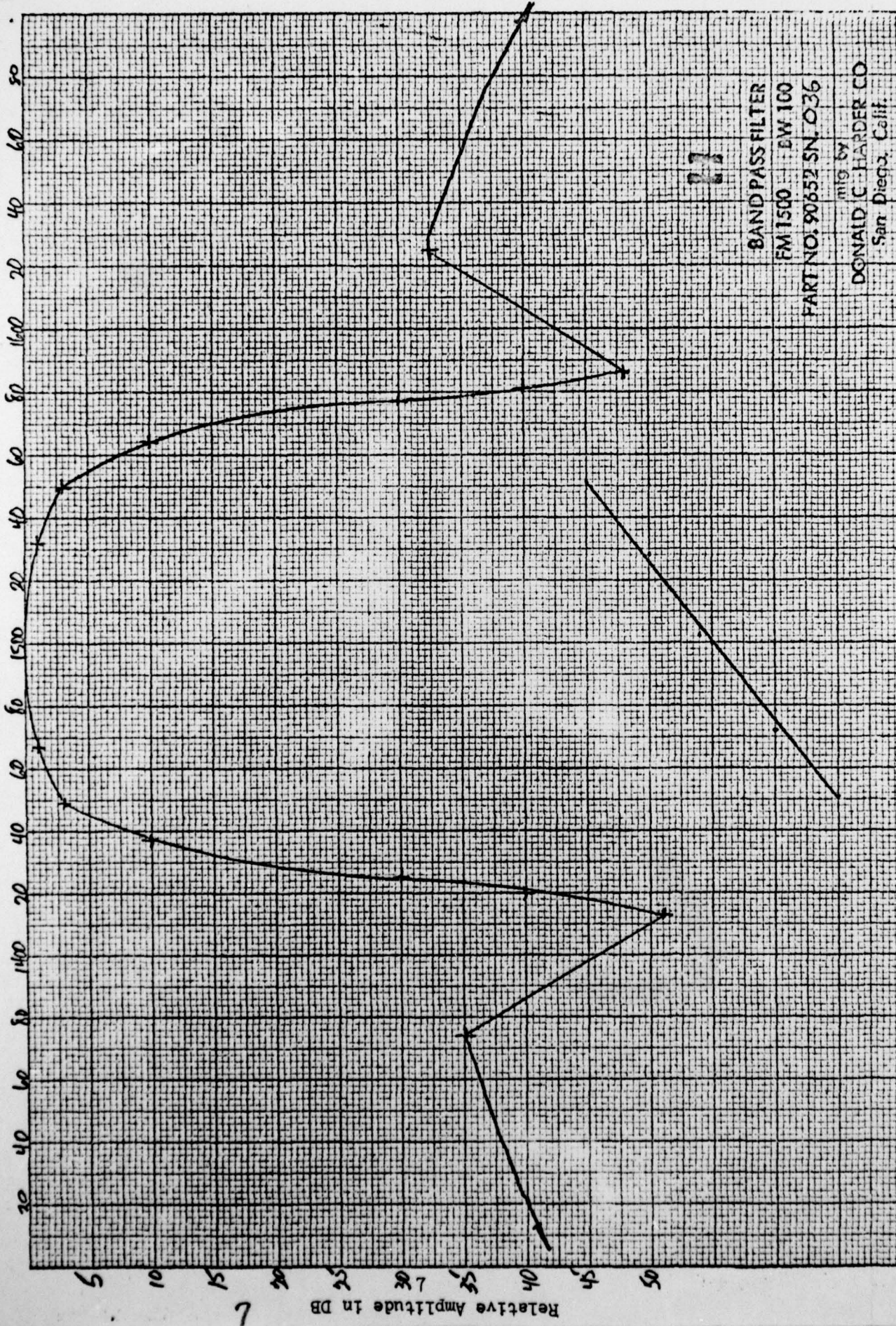

Figure 6. 100 cps bandpass filter response

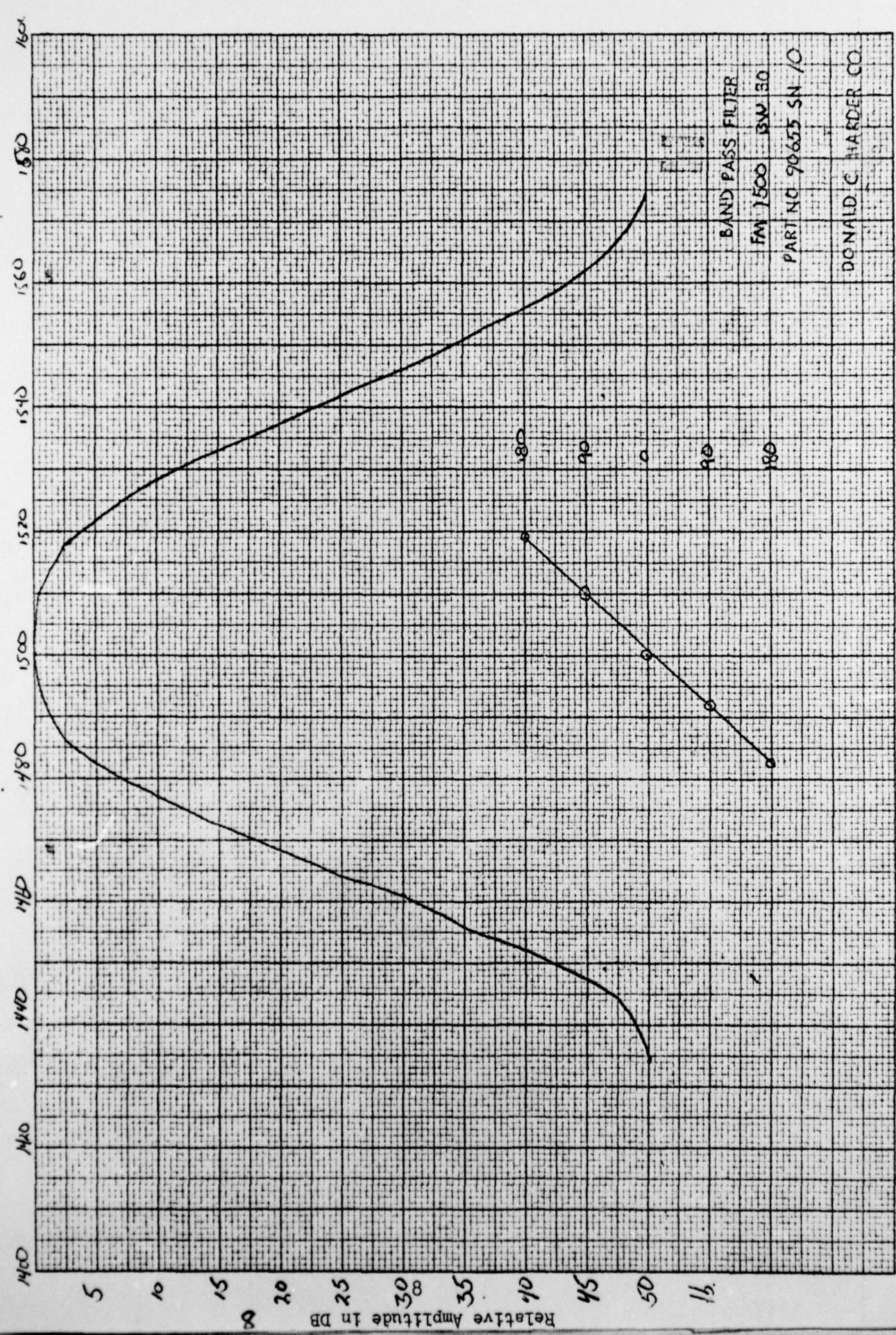

Figure 7. 30 cps bandpass filter response

Test setup number 2 was a filter-clip-filter configuration using filters identical to those in test number 1 to band limit the PN spectrum both prior to and after clipping. The output of the final filter, which in this case corresponds to the transmitted (or received), signal was measured and the crest factor ratio was calculated.

The test results are tabulated in Figure 8 for both test conditions. Photographs in support of the results are shown in Figure 9. Except where noted, the top photo of each figure displays the PN amplitude modulation at the filter output for test setup number 1 (clip-filter). The bottom photo displays the PN modulation at the final filter output for test setup number 2 (filter-clip-filter). The sinusoidal reference waveform for each photo had a peak to peak amplitude of about two (2) centimeters and a frequency corresponding to the center frequency of the filter(s) used in the test.

The negative sign associated with the crest factor ratio indicates the decrease in allowable source level for a PN signal relative to that for a sinusoidal signal if a system is peak power limited. The degree of amplitude modulation or crest factor ratio is a function of the bandwidth of the transmitted spectrum. If the entire spectrum could be transmitted, there should be no amplitude modulation because the time function could be reproduced with fidelity. This condition was approximated by making the transmitted bandwidth equal to the major lobe of the spectrum since most of the energy is contained within this region. The measured crest factor ratio of 0 db for the test conditions where the PNG drive frequency was equal to the filter bandwidth reflects this fact. The results also

PNG Drive Frequency F cps	Filter BW/Center Frequency cps/cps	Test No. 1 Clip-Filter				Test No. 2 Filter-Clip-Filter			
		$20 \log \left[\frac{V_{\sin}}{V_{pn}} \right]_{\text{rms}}$	$20 \log \left[\frac{V_{\sin}}{V_{pn}} \right]_{\text{pk}}$	Crest Factor Ratio DB		$20 \log \left[\frac{V_{\sin}}{V_{pn}} \right]_{\text{rms}}$	$20 \log \left[\frac{V_{\sin}}{V_{pn}} \right]_{\text{pk}}$	Crest Factor Ratio DB	
6000	100/1500	+13	+6	-7		+1	-3	-4	
6000	30/1500	---	---	---		+3	0	-3	
6000	100/50	+13	+6	-7		+1	-3	-4	
400	100/50	+3	-3	-6		+0.5	-3	-3.5	
300	100/50	+1.5	-3	-4.5		+0.3	-3	-3.3	
200	100/50	0	-3	-3		-0.3	-3	-2.7	
150	100/50	-0.5	-2	-1.5		-0.5	-2	-1.5	
100	100/50	-1	-1	0		-1	-1	0	
50	100/50	-1	-1	0		-1	-1	0	

Figure 8. Test Results

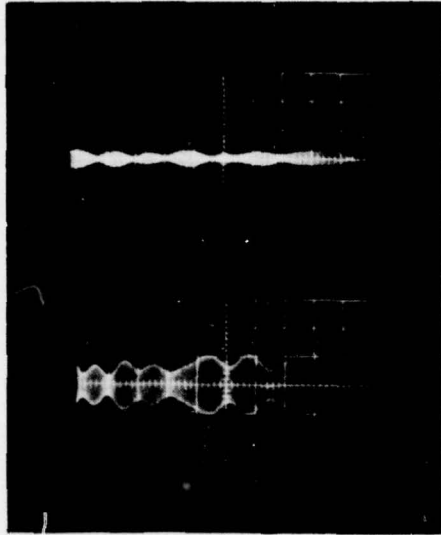

A.

PNG Clock: 6000 cps
 Filter(s): 100 cps at 1500 cps
 Scale: 1 v/cm; 10 ms/cm
 Top: Clip-Filter
 Bottom: Filter-Clip-Filter

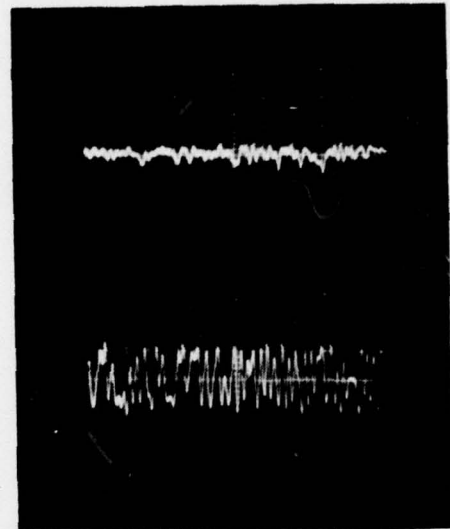

B.

PNG Clock: 6000 cps
 Filter(s): 100 cps at 50 cps
 Scale: 1 v/cm; 50 ms/cm
 Top: Clip-Filter
 Bottom: Filter-Clip-Filter

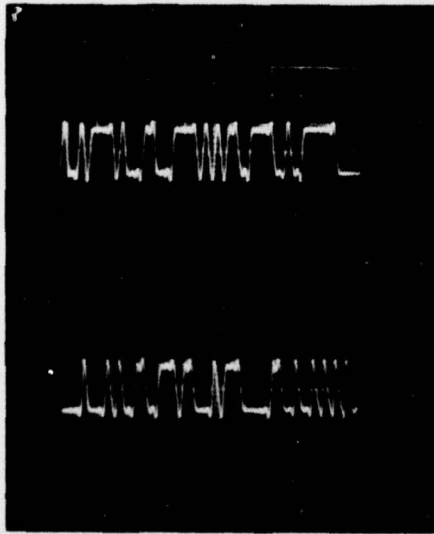

C.

PNG Clock: 100 cps
 Filter(s): 100 cps at 50 cps
 Scale: 1 v/cm; 50 ms/cm
 Top: Clip-Filter
 Bottom: Filter-Clip-Filter

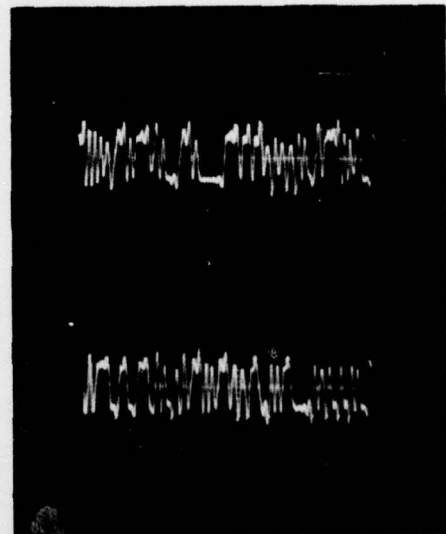

D.

PNG Clock: 200 cps
 Filter(s): 100 cps at 50 cps
 Scale: 1 v/cm; 50 ms/cm
 Top: Clip-Filter
 Bottom: Filter-Clip-Filter

Figure 9.

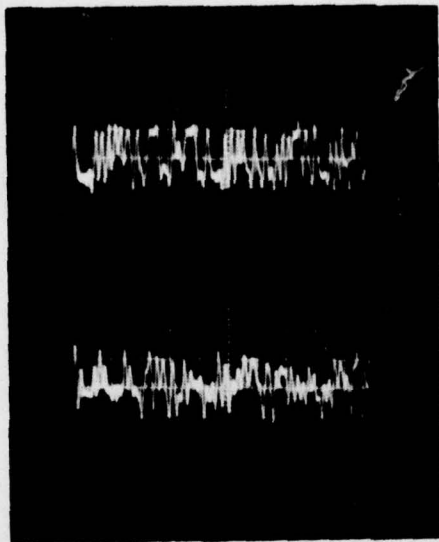

E.

PNG Clock: 400 cps
 Filter(s): 100 cps at 50 cps
 Scale: 1 v/cm; 50 ms/cm
 Top: Filter-Clip-Filter
 Bottom: Clip-Filter

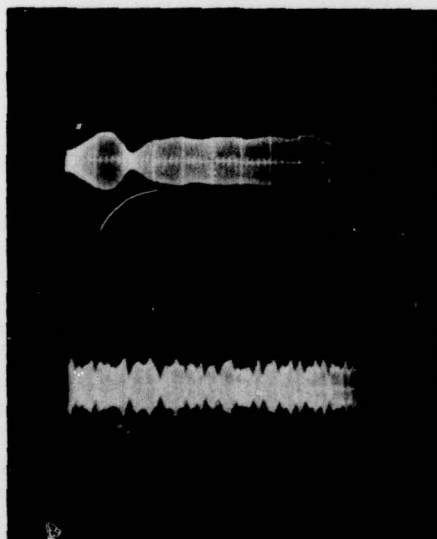

F.

PNG Clock: 6000 cps
 Filter(s): 100 cps at 1500 cps
 Scale: 1 v/cm
 Top: Filter-Clip-Filter
 10 ms/cm
 Bottom: Filter-Clip-Filter
 50 ms/cm

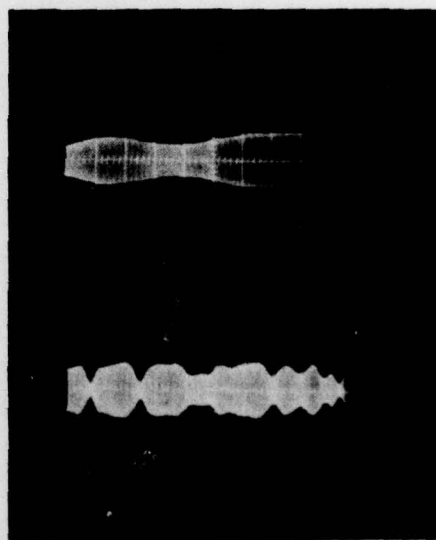

G.

PNG Clock: 6000 cps
 Filter(s): 30 cps at 1500 cps
 Scale: 1 v/cm
 Top: Filter-Clip-Filter
 10 ms/cm
 Bottom: Filter-Clip-Filter
 50 ms/cm

Figure 9 (Continued)

indicate that if the PNG output is filtered to the same bandwidth at different center frequencies within the flat region of the spectrum, the same degree of amplitude modulation will be present in the band limited PN signal.

CONCLUSIONS

If a PN transmission is used in a peak power limited system the following conclusions can be made.

1. The degree of amplitude modulation present in a PN signal is a function of the bandwidth of the transmitted spectrum and of the PNG drive frequency.

2. The PN signal suffers by as much as 4 db in effective power relative to that of a sinusoidal signal, if the PNG output is filtered-clipped-filtered to a 100 cps bandwidth in the flat region of the spectrum. As much as an additional 3 db loss can be expected if the PNG output is only clipped-filtered to the same 100 cps bandwidth.

3. If the PNG output is low pass filtered to a bandwidth equal to the PNG drive frequency (i.e., equal to the major lobe of the spectrum), the effective power transmitted will be the same as that for a sinusoidal signal having the same peak amplitude.

4. If the PNG output is filtered to the same bandwidth at different center frequencies within the flat region of the spectrum, the degree of amplitude modulation is independent of the center frequency.