

AD-A049 850

STANFORD UNIV CALIF DIGITAL SYSTEMS LAB  
EFFICIENCY OF COMPACT TESTING FOR SEQUENTIAL CIRCUITS.(U)  
DEC 76 J LOSQ  
DSL-TN-104

F/G 9/3

N00014-75-C-0601  
NL

UNCLASSIFIED

1 OF 1  
AD  
A049850

The microfiche contains 48 frames of technical information, organized into a grid. The frames include:

- Textual descriptions and abstracts.
- Block diagrams of sequential circuits.
- Timing diagrams and waveforms.
- Tables of data, likely performance metrics or test results.
- Small schematic diagrams.

END  
DATE  
FILMED  
3 - 78  
DDC

AD A 049850

Center for  
Reliable  
Computing

12

✓

EFFICIENCY OF COMPACT TESTING  
FOR SEQUENTIAL CIRCUITS

Jacques Losq

Technical Note No. 104  
December 1976

DDC  
RECEIVED  
FEB 13 1978  
A

*[Handwritten signature]*

Digital Systems Laboratory  
Departments of Electrical Engineering and Computer Science  
Stanford University  
Stanford, California

This work was supported in part by the National Science Foundation under Grant No. MCS 76-05327; and in part by the Joint Services Electronics Program (JSEP) under Contract No. N00014-75-C-0601.

(See 1473)

DISTRIBUTION STATEMENT A  
Approved for public release;  
Distribution Unlimited

AD No. [unclear]  
DDC FILE COPY

EFFICIENCY OF COMPACT TESTING  
FOR SEQUENTIAL CIRCUITS

Jacques Losq

Digital Systems Laboratory  
Stanford University  
Stanford, California 94305

ACQUISITION NO.	
NTIS	White Section <input checked="" type="checkbox"/>
GPO	Diff Section <input type="checkbox"/>
UNANNOUNCED <input type="checkbox"/>	
JUSTIFICATION.....	
BY.....	
DISTRIBUTION/AVAILABILITY GROUP.....	
Dist.	AVAIL. CODE/OR SPECIAL
A	

ABSTRACT

Compact testing uses random inputs to test digital circuits. Detection is achieved by comparison between some statistic property of the circuit under test, like the frequency of ones on the output line, and the same property for the fault-free circuit. In this paper we show that compact testing can be efficiently used for sequential machines, although it has some inherent limitations. Synchronization is achieved by a long sequence of random inputs whose length is circuit dependent. However, for most sequential circuits synchronization can be achieved in a few seconds. The great majority of failures inside the memory elements are easily detected, even with short tests. Compact testing also detects most of the failures in the combinational parts. There, its efficiency is largely dependent upon the test length and also the characteristics of the random number generators. However, even the most subtle failures may be detected if the test has sufficient length. Some of the requirements and trade-offs to achieve efficient detection are presented.

Index Terms: Sequential circuits, testing, random inputs, synchronization, failures, detection.

## I. INTRODUCTION

The ever increasing complexity of digital circuits has made the testing problem extremely difficult. The deterministic methods for test generation (D. Algorithm, [J.P. Roth, 1967], [W.G. Bouricius, 1971]; Boolean Difference, [F.F. Sellers, 1968]; Poage's Method, L.J.P. Poage, 1964]; etc.) become prohibitively expensive for large circuits. The number of stuck-at faults increases exponentially with the number of gates. For large LSI chips, like microprocessors, the amount of computation required to generate a vector test set that covers all single stuck-at and some multiple faults is extremely large. Furthermore, LSI failure modes may not conform to the stuck-at model and such failures as pattern-sensitive failures may not be covered by the test obtained.

Random test generation methods [M.A. Breuer, 1971], [J.C. Rault, 1971], [V.D. Agrawal, 1972] and [P. Agrawal, 1975] are used to overcome some of the computation costs of the deterministic methods. Random input patterns are fed to a prototype of the circuit to test (or a simulator) and are analysed for their ability to catch failures. These methods give, in general, far larger test sets. However, there have been some studies to try to optimize them (by assigning different weights to the input leads [M.D. Schnwinmann, 1975] or by interactive use [K.P. Parker, 1976]).

Some testing methods bypass the need for any prior test generation. Quite often, testing is economically achieved by comparing the outputs of the unit under test with the outputs of a known good unit (also called "gold unit") while both units are fed by the same sequence of random inputs. The efficiency of such testing methods has been analysed by

[J.J. Shedlestky, 1975]. However, the need for a gold unit may be bothersome (large or expensive gold unit). Moreover, the reliability of the gold unit is not guaranteed and the synchronization of the two units may also cause problems.

Recently, a new testing method, which also does not necessitate prior test set generation, has been implemented in some test equipments. The unit under test is fed by random or pseudo-random inputs, and some statistics of the outputs (for example, the number of logic ones or transitions) are computed. If the output statistics satisfy some known properties (for example, a given frequency of ones), the unit is said to have passed the test. We will refer to such testing methods as compact testing. An example of commercial testers implementing this method is the Fluke Trendar 1000 Logictester. Such a method has been investigated by [J.P. Hayes, 1975], [J.P. Hayes, 1976] and [K.P. Parker, 1976]. Its general efficiency, when applied to combinational circuits, has been investigated by [J. Losq, 1976]. The goal of this paper is to obtain quantitative measures for the efficiency of compact testing applied to sequential circuits.

## II. TEST DESCRIPTION

Compact testing of sequential circuits is achieved in three steps. The first part of the experiment consists in feeding the circuit a long sequence of random inputs. The rationale for this is to try to synchronize the circuit. The next step consists in sending another long sequence of random inputs during which output statistics are gathered. The third step is the comparison between the obtained statistics and the correct ones. The circuit is then declared fault-free if the statistics match. For this study, one will assume that the output statistics that are gathered during the second step of the experiment are the frequencies of logic ones on each output line. The study by [J.P. Hayes, 1976] tends to conclude that it is the best statistic. Figure 1 gives the general description of compact testing.

The length of the input sequence during the first step of the experiment (the synchronization step) will be denoted by  $T_0$ . Similarly, the length of the sequence during the statistic gathering step will be denoted by  $T$ .

The circuit under test is a sequential machine,  $M$ , characterized by its five t-uple [E.J. McCluskey, 1965], [M.A. Arbid, 1969]:

$$M = \langle I, O, Q, \delta, \lambda \rangle$$

with  $I$  = input alphabet,  
 $O$  = output alphabet,  
 $Q$  = state set,

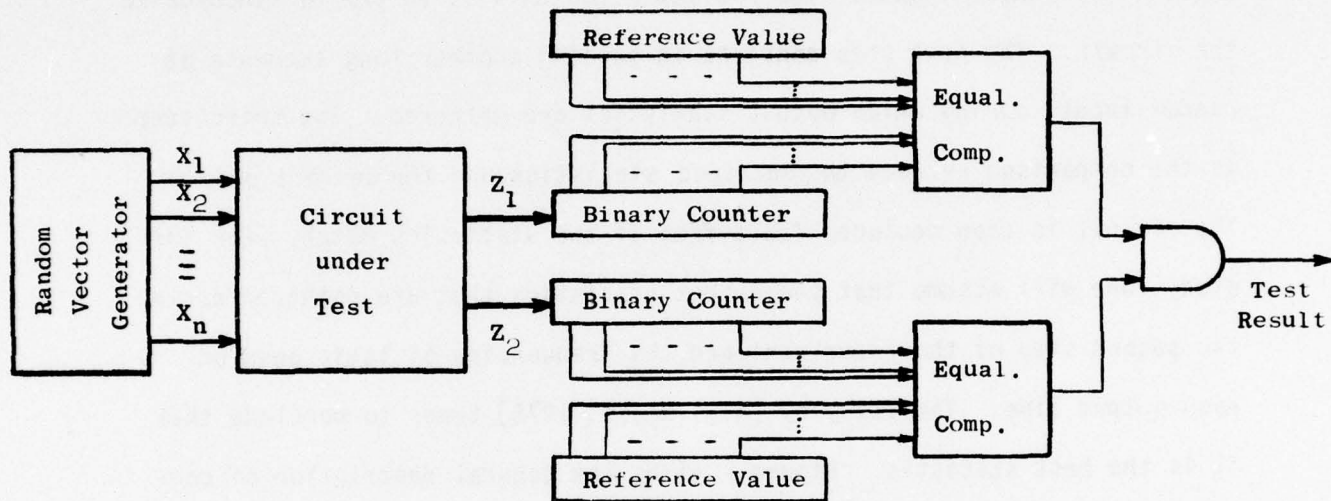

Fig. 1. General conception of random testers for n-input 2-output circuits.

$$\delta = Q \times I \xrightarrow{\delta} Q = \text{state transition function,}$$

$$\lambda = Q \times I \xrightarrow{\lambda} O = \text{output function in Mealy-type machines,}$$

$$Q \xrightarrow{\lambda} O = \text{output function in Moore-type machines.}$$

In the following we will adopt the following conventions:

- The machine has  $n$  binary input variables:  $X_1, X_2, \dots, X_n$ ,
- All the  $2^n$  possible input vectors,  $A_0, A_1, \dots, A_{2^n-1}$  accepted by the machine,
- The machine has  $m$  binary output variables,  $Z_1, Z_2, \dots, Z_m$ ,
- The  $2^m$  output vectors are denoted by  $B_0, B_1, \dots, B_{2^m-1}$
- The machine, when it is fault free, has  $q$  states,  $Q_1, Q_2, \dots, Q_q$ ,
- The machine is a Mealy-type machine (Moore-type machines are special case of Mealy-type machines).

Mathematically, one has the following relations:

$$M = \langle I, O, Q, \delta, \lambda \rangle,$$

$$I = X_1 \times X_2 \times \dots \times X_n = \left\{ A_0, A_1, \dots, A_{2^n-1} \right\},$$

$$O = Z_1 \times Z_2 \times \dots \times Z_m = \left\{ B_0, B_1, \dots, B_{2^m-1} \right\},$$

$$Q = \left\{ Q_1, Q_2, \dots, Q_q \right\},$$

$$X_1, X_2, \dots, X_n, Z_1, Z_2, \dots, Z_m = \{0,1\},$$

$A_i$  corresponds to the input vector for which  $\langle X_1, X_2, \dots, X_n \rangle$  is the binary representation of  $i$ .

The random vector generator that drives the circuit under test (cf. Figure 1) produces random inputs. It is stationary and characterized by the probabilities,  $x_i$ , that the logic value on line  $X_i$  is a one. So, one can easily obtain the set of probabilities,  $a_i$ 's, of all possible input vectors, [K.P. Parker, 1976]. For clarity, we will use vector notation:

$$\vec{A} = \begin{bmatrix} a_0 \\ a_1 \\ - \\ - \\ - \\ a_n \\ 2^{-1} \end{bmatrix}$$

with  $a_i = \text{Prob}(\text{input vector } A_i)$ .

The strategy for deciding the "health" of the device under test is simply to compare the number of ones counted during the second step of the experiment with the correct number for every output line. If the random number generator is reset at the beginning of each test experiment, it will always produce the same sequence of test vectors. This allows exact comparison. Any discrepancy between the observed statistic and the correct one indicates the presence of a fault or an improper synchronization. If the random number generator is not reset, then it is not possible to guarantee that two identical circuits produce exactly the same number of ones on each of their outputs (because of the different test sequences). However, as it will be seen later, two

identical circuits, whatever their initial state, will still produce about the same number of ones. So, the criteria for a circuit to pass the test is that, for every output line  $Z_i$ , the observed frequency of logic ones,  $\hat{z}_i$ , does not differ more than  $\epsilon_i$  from the correct value  $z_i$ .

Circuit passes tests iff  $\|\hat{z}_i - z_i\| < \epsilon_i$

The vector  $\vec{\hat{z}}$  of the output probabilities  $\hat{z}_i$  is called the signature of the circuit under test while the vector  $\vec{z}$  of the correct output probabilities  $z_i$  is called the correct signature (or reference signature).

### III. SYNCHRONIZATION

One of the problems in testing sequential circuits is synchronization. When exercised, the responses of sequential machines are dependent upon their initial states. Deterministic test set generation methods use synchronizing sequences (or homing sequences) to preset the circuit under test in a known state (or to determine the initial state) [R. Boute, 1972]. Compact testing uses a similar approach. A long series of  $T_0$  random inputs is injected to the circuit to achieve a probabilistic synchronization.

Let the vector  $\vec{t}S$ , called Probabilistic State, denote the state probabilities for the machine after the tth input has been applied.

$$\vec{t}S = \begin{bmatrix} t^{s_1} \\ t^{s_2} \\ - \\ - \\ - \\ t^{s_q} \end{bmatrix}$$

with  $t^{s_i}$  = probability to be in state  $Q_i$  after the tth input. From the state transition diagram of the machine and the input probability vector,  $\vec{A}$ , it is easy to obtain the state transition probability matrix,  $N$ :

$$N = \begin{bmatrix} n_{ij} \end{bmatrix}_{q \times q}$$

with  $n_{ij}$  = Prob (to go from state  $Q_i$  to state  $Q_j$  in one step | the input vector is random with probability distribution given by the vector  $\vec{A}$ ).

With such a notation, the probabilistic state after the  $t$ th input,  $\vec{S}_t$ , is

$$\vec{S}_t = \vec{S}_0 \cdot N^t$$

where  $\vec{S}_0$  is the probabilistic state at the start of the test.

If the machine under test is strongly connected (which is to say that from every state it is possible to reach any other state), then the matrix  $N$  corresponds to the matrix of an ergodic Markov chain [T.L. Booth, 1967]. Thus, the probabilistic state,  $\vec{S}_t$ , approaches a constant value,  $\vec{w}$ , as the length of test,  $t$ , increases:

$$\lim_{t \rightarrow \infty} \vec{S}_t = \lim_{t \rightarrow \infty} [\vec{S}_0 \cdot N^t] = \vec{w}.$$

This means that after a long sequence of random inputs, the probability of any given state is fixed and independent of the initial state. So, one can say that any long sequence of random inputs is a probabilistic synchronizing sequence in the sense that the final probabilistic state is independent of the initial state.

The necessary number of random input needed to achieve proper probabilistic synchronization ( $\vec{S}_t$  is different from  $\vec{w}$  by less than  $\epsilon$ ) is directly dependent upon the eigenvalues of the matrix  $N$ . Any power of the matrix  $N$  can be written as

$$N^t = \sum_{i=1}^q \lambda_i^t \cdot N_i$$

where the  $\lambda_i$ 's are the eigenvalues of  $N$  and the  $N_i$ 's matrices are

independent of  $t$ . The convergence radius of  $\vec{S}_t$  (towards  $\vec{w}$ ) is the eigenvalue with the larger absolute value (besides the eigenvalue,  $\lambda_1=1$ , which always exists). For example, a binary counter with  $u$  stages (counting from 0 to  $2^u - 1$ ) will reach its probabilistically synchronized state  $\vec{w}$ , within a precision of  $10^{-X}$ , after a sequence of approximately  $.46 \times X \times 2^{2u}$  random inputs of the same likelihood. In this example, the required length of the synchronizing sequence is fairly large (around 1.3 million inputs for a 10-stage counter to reach the steady state within .1%). However, this is a worst case example and, even though, the time required for such a probabilistic synchronizing sequence will be less than 1 second for most present-day implementations.

When the random number generator is reset at the beginning of each new test experiment, deterministic synchronization can be achieved if the sequence of  $T_0$  random inputs contains a subsequence which is a deterministic synchronizing sequence. However, if the length of the deterministic synchronizing sequence is substantial, the likelihood that it will occur in a random sequence may be extremely small. For example, if the shortest synchronizing is 100 inputs long and the machine has 10 input variables, it may require as many as  $10^{300}$  random inputs of the same likelihood to have a significant chance to achieve deterministic synchronization (cf., Appendix I). So, unless synchronizing sequences are quite short (for example, when there are reset lines), it is unlikely that sequential machines are deterministically synchronized at the beginning of the statistic gathering (cf, Figure 2).

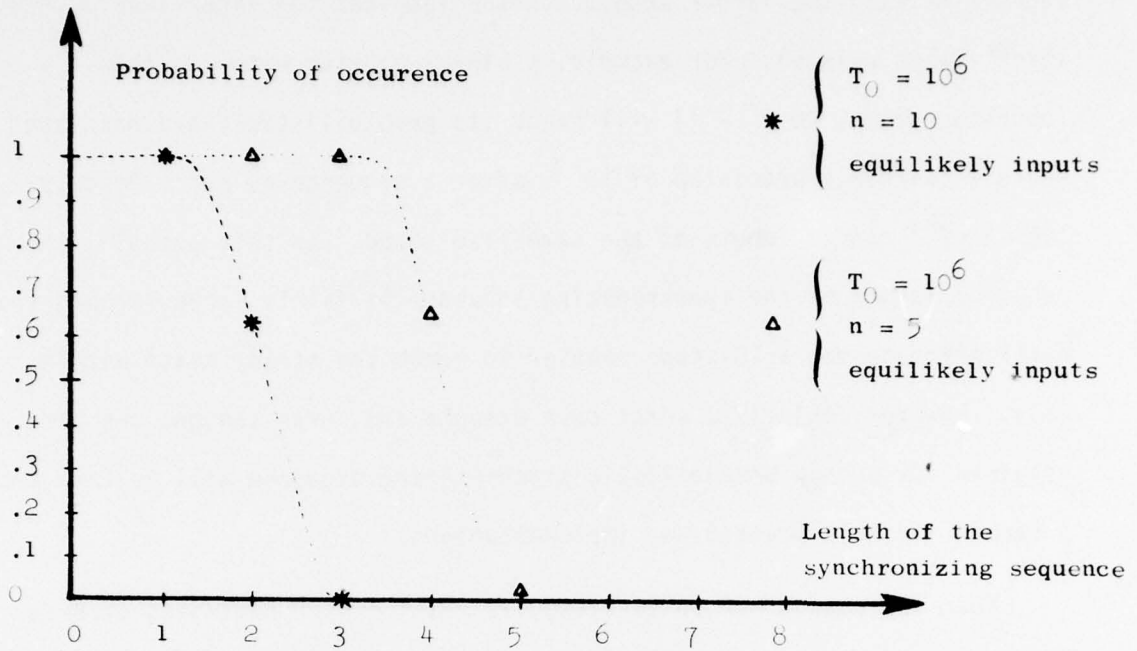

Fig. 2. Probability that a random sequence contains a synchronizing sequence.

#### IV. REJECTION OF FAULT-FREE CIRCUITS

Some fault-free circuits may not pass the test because of the randomness of the test sequence and its finite length. In the following, we will assume that the internal states constitute the outputs (one line for each state). So, the signature of the circuit under test,  $\vec{z}$ , is

$$\vec{z} = \frac{1}{T} \sum_{t=1}^T T_{0+t} \vec{s} \cdot N^t = \frac{1}{T} \left[ \begin{array}{c} \vec{s} \\ 0 \end{array} \cdot \sum_{t=1}^T N^{T_{0+t}} \right]$$

As it can easily be seen, the signature of the circuit under test approximates  $\vec{w}$ , which is the correct signature. The matrix  $N$  can be written as :

$$N = \sum_{i=1}^q \lambda_i \cdot N_i \quad \text{(orthogonal decomposition, } \lambda_i = 1, \text{ the } \lambda_i \text{ ordered by decreasing magnitude)}$$

and

$$N^t = \sum_{i=1}^q \lambda_i^t \cdot N_i$$

So, the difference between  $\vec{z}$  and  $\vec{w}$  is

$$\vec{z} - \vec{w} = \frac{1}{T} \left[ \begin{array}{c} \vec{s} \\ 0 \end{array} \cdot \sum_{t=1}^T \left( \sum_{i=2}^q \lambda_i^{T_{0+t}} \cdot N_i \right) \right]$$

As  $T_0$  is fairly large, one has only to consider the terms in  $\lambda_2$  ( $\lambda_1$  being 1 is cancelled by  $\vec{w}$ ). So,

$$\| \vec{z} - \vec{w} \| \approx \frac{1}{T} \cdot \left\| \frac{\lambda_2^{T_0+1}}{1-\lambda_2} \right\| \cdot \left[ \begin{array}{c} \vec{s} \\ 0 \end{array} \cdot N_2 \right]$$

$$\left\| \hat{\vec{z}} - \vec{w} \right\| \approx \left[ \frac{1}{T} \cdot \frac{\lambda_2}{1-\lambda_2} \right] \cdot \left[ \lambda_2^T \cdot \vec{0} \cdot \vec{S} \cdot N_2 \right]$$

The second factor represents the accuracy with which the probabilistic synchronization has been achieved. As it is clear from the first term, the probability of rejecting fault free units is extremely low (even when probabilistic synchronization was poorly achieved) if the eigenvalue with higher absolute value,  $\lambda_2$ , is negative. Figure 3 gives the dependency between the approximation of  $\vec{w}$  by  $\hat{\vec{z}}$  and the length of the test.

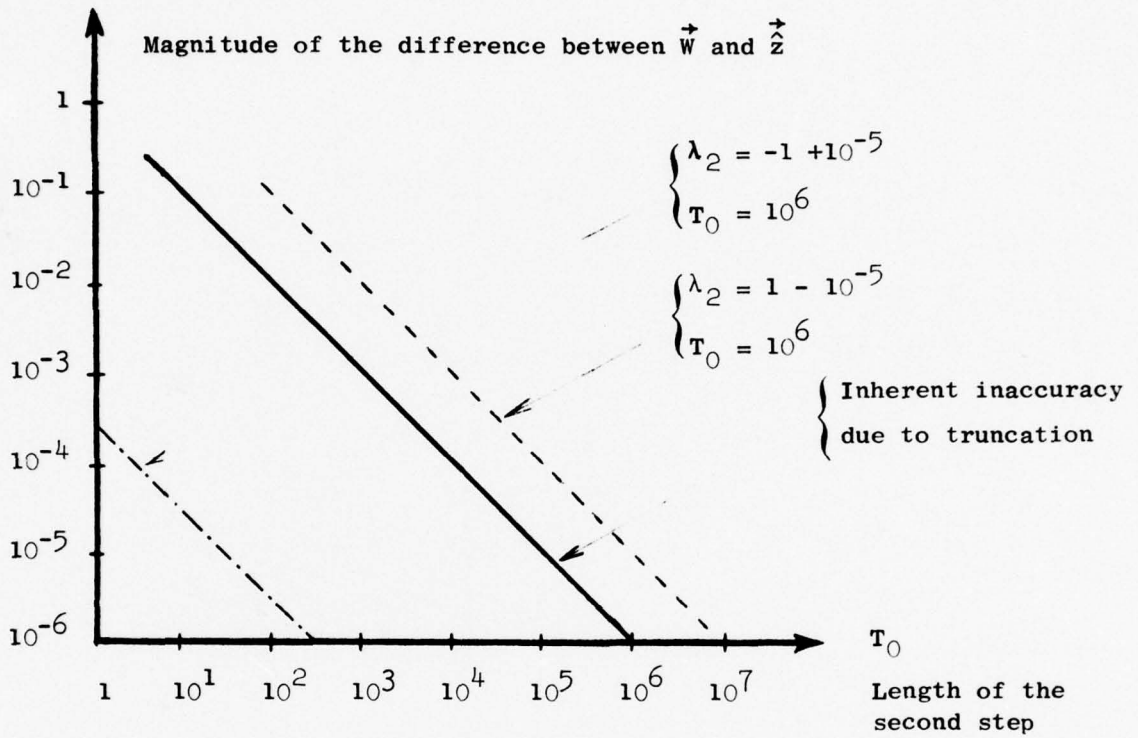

Fig. 3. Difference between the steady state  $\vec{W}$  and its approximation  $\vec{z}$  as a function of the test length.

## V. DETECTION OF FAILURES

### V.1 INHERENT LIMITATIONS OF COMPACT TESTING

It has been shown by [E.J. McCluskey, 1975] that random testing can detect any failure inside a combinational circuit, if the input probabilities are correctly chosen. The output probability becomes the fixed point decimal representation of the truth table (expressed as a binary number). So, random testing can be used to identify combinational circuits (even though it is highly impractical). However, for sequential circuits such a statement is false. Whatever the input probabilities, whatever the sequential machine under test, there will always be different machines which have the same signature (so they will pass the test). The proof is fairly simple. The signature,  $\vec{w}$ , of a sequential machine is given by the following equation:

$$\vec{w} \cdot M = \vec{w}$$

But any matrix  $M'$  obtained from  $M$  by some column permutation will have the same signature. So, compact testing cannot guarantee that it will detect all the possible failures (and this is independent of the test length). However, most of the failures that do occur can be detected.

### V.2 FAILURES IN THE OUTPUT CIRCUITRY

Most of the sequential machines have the architecture of Figure 4. The memory elements are flip flops. They are controlled by a combinational circuit synthesizing the excitation functions from the circuit inputs and the flip-flop outputs. The circuit outputs are obtained by combinational logic. Failures can occur either in the memory elements (flip flops),

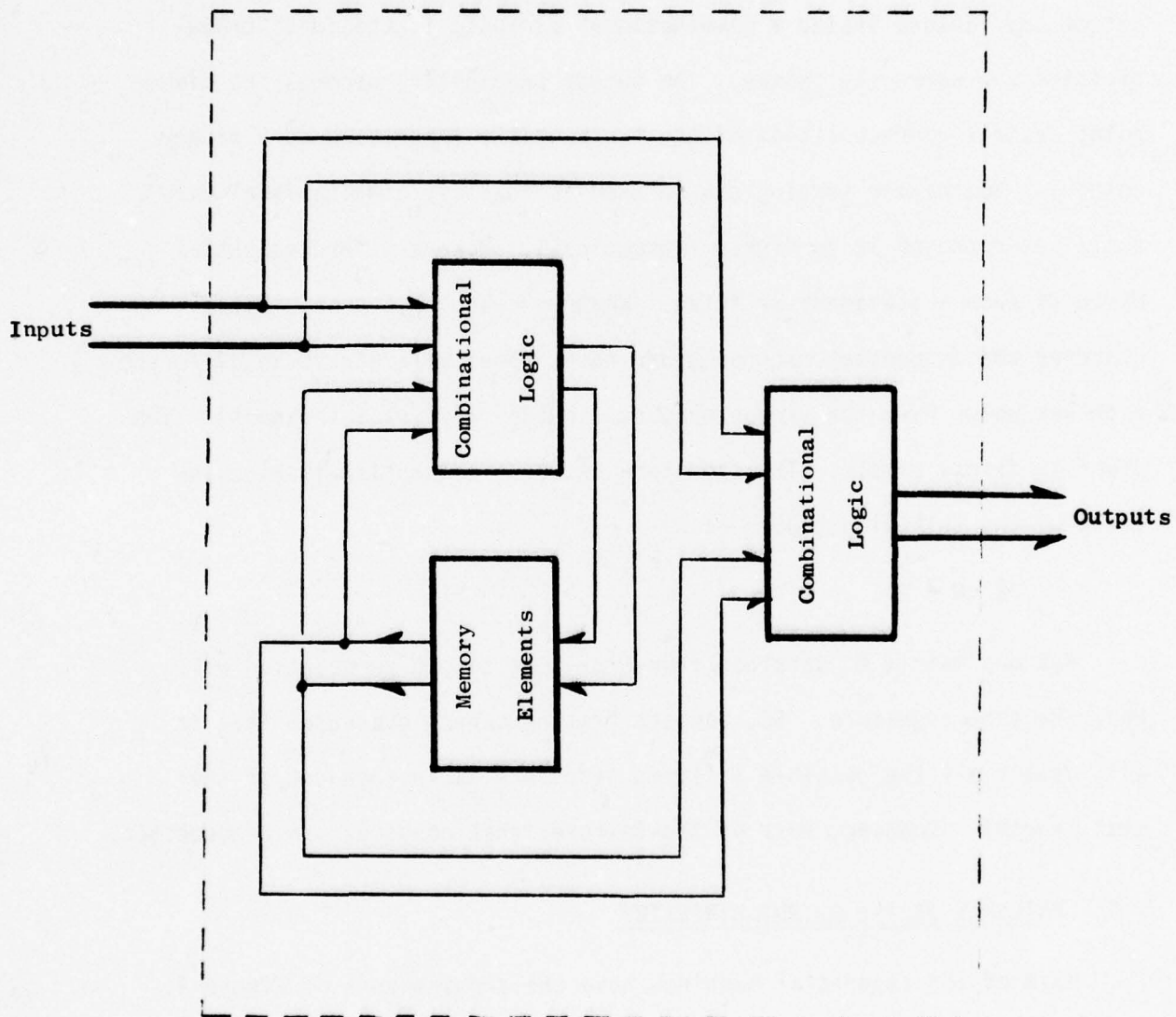

Fig. 4. General architecture of sequential circuits.

in the combinational circuit controlling these flip-flops or in the combinational logic synthesizing the circuit outputs. For simplicity of this study, we will consider these three cases separately. It is quite intuitive that, in general, multiple failures are easier to detect (cumulative effects).

The failures that are restricted to the combinational logic synthesizing the circuit outputs from the inputs and the flip-flop outputs (Mealy-type machines) do not affect the state transitions. So, this problem is analogous to the problem of detecting failures in combinational logic (with input probabilities determined by the circuit probabilistic state).

Failures can affect the validity of one or several of the output variables. It is obvious that the failures that affect several output lines are easier to be detected (the probabilities of ones on several output lines will not match the correct values). So, one can get a lower bound for detection efficiency by looking only at single output circuits. The output,  $Z$ , is a combinational function of the inputs ( $A_i$ 's) and the states ( $Q_j$ 's). When the circuit is fault-free, the output probability is  $z$ . The possible faults that affect the output circuitry may be very varied in terms of their effects. A stuck-at fault directly on the output line will be immediately detected (the probability,  $\hat{z}$ , of the faulty circuit will always be 0 or 1). In general, one can get a very conservative model for the faults if one considers that on the average a fault will affect only a few cells of the truth table (output as a combinational function of the inputs and states). It is analogous to say that the output will be valid most of the time but incorrect for a few combinations of input variables and internal states.

Under this assumption, it has been shown by [J. Losq, 1976] that the distribution of the output probability,  $\hat{z}$ , over all possible faulty circuits is a gaussian distribution.

$$\text{Prob} \left( \hat{z} \in \left[ u - \frac{du}{2}, u + \frac{du}{2} \right] \right) = \text{Gauss} (u, z + \Delta, \sigma^2) \cdot du$$

with  $z$  = output probability of the correct circuit,

$$\Delta = (1-2z) \cdot y,$$

$y$  = proportion of the cells in the truth table that are affected by a fault (characterizes the extend of a failure),

$$\sigma^2 = \text{variance} = y(1-y) \cdot \left( \begin{matrix} \rightarrow \text{tr} & \rightarrow \\ A & \cdot & A \end{matrix} \right) \cdot \left( \begin{matrix} \rightarrow \\ \bar{w} & \cdot & \bar{w} \text{tr} \end{matrix} \right).$$

The fact that the distribution is not centered around the correct probability and that the variance is quite small implies that most of the failures in output circuitry will be detected, cf. Figure 5 (the difference between  $\hat{z}$  and  $z$  is very likely to be greater than the acceptance window  $\epsilon$ ). So, one can state that compact testing is efficient to detect failures located in the combinational logic synthesizing the outputs. For example, in the case of Figure 5, more than 99% of all failures will be detected.

### V.3 FAILURES IN THE MEMORY ELEMENTS

The simplest and most general assumption to make concerning failures in the memory elements (flip-flops) is that they will correspond to one of the flip-flops being stuck (stuck-at failure at the flip-flop output). When the output of a flip-flop is stuck, half the states are unreachable. Half the columns and rows of the transition matrix  $N'$  will be zero.

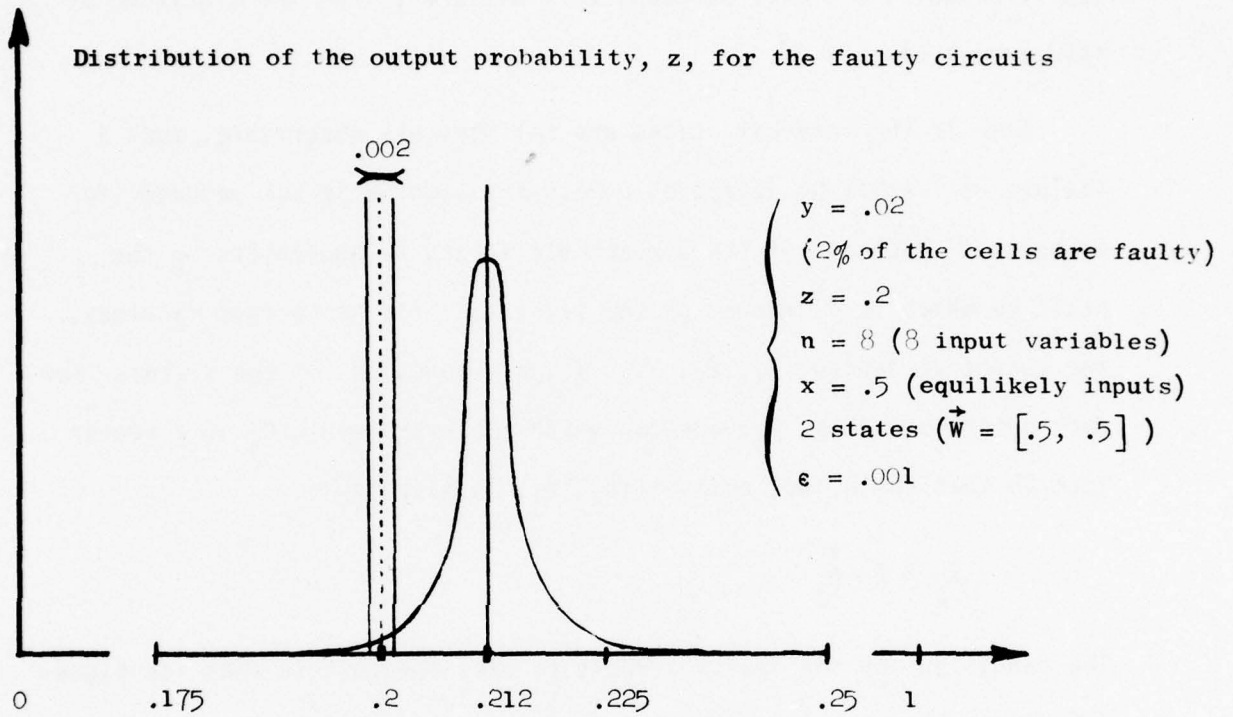

Fig. 5. Distribution of the output probability,  $\hat{z}$ , for the faulty circuits (the test acceptance window is shown for comparison).

Consequently, half of the elements of the steady-state vector  $\vec{w}$  are also zero. If the internal states are directly observable at the the circuit output, these failures will be immediately detected. The signature of the faulty circuit,  $\vec{w}'$ , will be completely different from the signature of the correct circuit,  $\vec{w}$ .

Even if the internal states are not directly observable, such a failure will still be detected, unless the machine is not reduced (for example, if each one of the unreachable states is equivalent to the state to which it is mapped by the failure). For Moore-type machines, the output variables,  $Z_1, Z_2, \dots, Z_m$ , are functions of the states. For each output variable,  $Z_j$ , one can write the truth table  $C_j$  in a vector form so that the output probability,  $z_j$ , is given by:

$$z_j = \vec{w} \cdot \vec{C}_j$$

The condition for the faulty circuit to pass the test is that its signature is equal to the reference signature:

$$\vec{w}' \cdot \vec{C}_j = \vec{w} \cdot \vec{C}_j \quad \forall j \in \{1, 2, \dots, m\}$$

But every element of  $\vec{w}'$  is different from the corresponding element in  $\vec{w}$  (half of  $\vec{w}'$  is zero). So, this set of  $m$  equations is extremely restrictive on the values of  $\vec{w}'$  that satisfy it. So, one can say, without loss of generality, that the signature of the faulty circuit will differ from the reference signature. Mealy-type machines can be treated similarly. So, as a general statement, it is safe to say to every failure that affects the memory elements will be detected by compact testing.

#### V.4 FAILURES IN THE COMBINATIONAL LOGIC CONTROLLING THE MEMORY ELEMENTS

Failures that take place in the combinational logic that synthesizes the excitations for the flip-flops affect the state transition diagram of the circuits. Failures are quite diverse. A stuck-at constant value on the R input of an R-S flip-flop may be analogous to a flip-flop failure. On the other hand, some failures may change only a few transitions in the transition diagram (for example, a failure may change only the transition between states  $Q_i$  to  $Q_j$  under input  $A_k$ ). These last ones will be the most difficult to detect because their effects on the system operation is somewhat limited (in a statistical sense). So, as it was done for the output combinational logic, we will only consider these failures in the analysis. This will provide a meaningful lower bound for detection efficiency.

Each of the flip-flops that compose the circuit memory has its own excitation synthesized by combinational logic. It is natural to assume that failures will affect the excitation of only one flip-flop. It is also natural to use the same model as used in Section V.2 to describe the effects of failures. Each failure changes only a few cells in the excitation truth table (table giving the flip-flop excitation as a function of the circuit inputs and internal states). The cells affected are randomly distributed all over the truth table. For every faulty cell, the corresponding state transition (inputs + state  $\rightarrow$  excitation  $\rightarrow$  state transition) will be different from the correct one. Reciprocally, for every correct cell in the excitation table both the faulty and the fault-free machines have the same transition.



$$\Delta \vec{w} (I - N - \Delta N) = \Delta \vec{w} (I - N) - \Delta \vec{w} \cdot \Delta N \approx \Delta \vec{w} (I - N)$$

So, if the changes on  $N$ , associated with the  $v$  faulty cells are respectively  $\Delta N_1, \Delta N_2, \dots, \Delta N_v$ , then

$$\Delta \vec{w} (I - N) \approx \sum_{i=1}^v \vec{w} \cdot \Delta N_i = \vec{w} \sum_{i=1}^v \Delta N_i .$$

If the number of faulty cells is small (compared to the total number of cells in the truth table), then one can state that at least two elements of  $\vec{w}$  will be changed by the faults. The average magnitude of this change is

$$\Delta w \approx w \cdot \sum_{i=0}^{2-1} a_i^2 = w \cdot \prod_{i=1}^n [x_i^2 + (1 - x_i)^2]$$

So, the relative change is directly dependent upon the input probabilities  $x_i$  (the characteristics of the random number generator). It can be noted that the variation in  $w$  is independent of the function realized by the circuit. One can also note that there is a trade-off for choosing the set of input probabilities (the  $x_i$ 's). Detection of failures in the output circuitry are facilitated when the  $x_i$ 's are close to .5 (this decreases the variance,  $\sigma^2$ , in the distribution of the signature, cf. Section V.2). On the other hand, detection of failures in the excitation circuitry is improved if the  $x_i$ 's are far from .5.

So, most of the failures located in the excitation circuitry can be detected by compact testing. If they affect very significantly one excitation function, then they tend to have effects similar to memory

failures, and thus, they will be easily detected. Even when their effects are very limited, they will produce a change in the steady-state of the circuit. Such a change can be detected if the test is long enough. Figure 6 gives the minimum test length required to detect one of these very subtle failures. It should also be noted that clock-related failures will be detected by compact testing for they will be equivalent to memory failures or excitation failures.

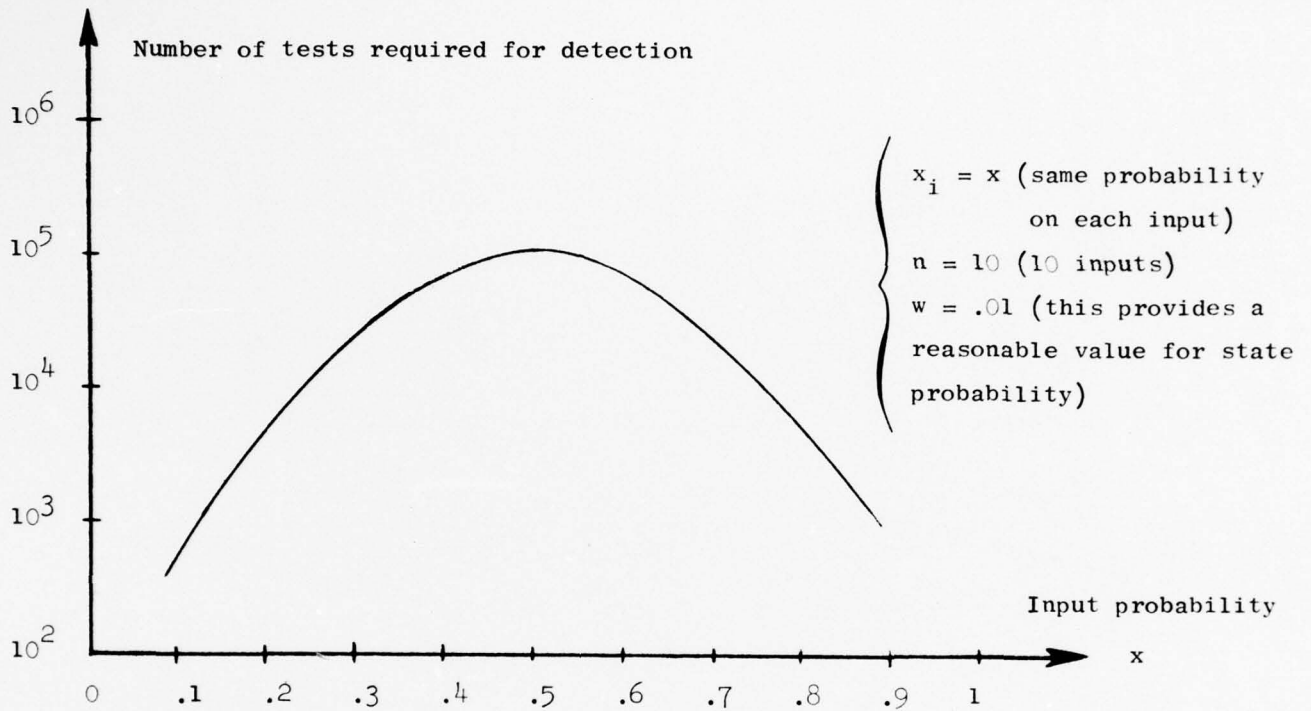

Fig. 6. Minimum number of test inputs to achieve detection of failures in the logic synthesizing the flip-flops excitations.

## VI. CONCLUSIONS

Compact testing is a very simple method to test complicated circuitry. Circuit analysis is avoided. Testing equipment is extremely simple and can be used with almost any kind of circuit. There is no need for large libraries of test sets or reference output sequences. This is obtained at the cost of far longer test sets. However, the speed of most digital circuits nowadays allows several million inputs per second. So, very large test sets ( $10^6$  inputs and higher) are not a penalty, especially when they are random (algorithmic generation).

It has been previously shown that random testing is an efficient method to test combinational circuits. However, the problems associated with sequential machines can make one doubt its usefulness for sequential machines (even though it is practically used for this purpose). Here, we showed that the problem of initial state can be simply overcome. A long sequence of random inputs, during which one does not look at the circuit outputs, acts as a synchronizing sequence for compact testing, even when the machine does not possess deterministic synchronizing sequences. The probability that compact testing rejects fault-free circuits can be made arbitrarily small by increasing the length of the synchronization period. For most practical applications, the rate of rejecting fault-free circuits is negligible.

Even though compact testing can never guarantee one hundred percent confidence in its results, it is still an efficient way to detect most of the failures that can occur in sequential machines. Failures affecting

the memory elements (or the delay elements in the feedback loops) are guaranteed to be detected. Similarly, permanent clock failures do not escape detection. Failures in the combinational logic synthesizing the output functions from the circuit inputs and its states, are also likely to be detected. It was shown that the corresponding signature differs from the correct one by a quantity that is a random variable of non-zero mean and extremely small variance. so, the efficiency to detect these failures is a monotonically increasing function of the test length. Most of the failures that affect the excitation of the flip-flops (or the state transitions) can also be detected. Depending on the extent with which they affect the operation of the circuit, the change they induce on the circuit signature is more or less accentuated. Failures that drastically change the circuit operation are extremely likely to be detected. However, even the more subtle failures, those which change only one state transition, can be caught by the test if it is long enough.

Because of the similarity between compact testing and random test set generation, one may hope that the efficiency of compact testing could be enhanced by some kind of interactive use (or feedback between the circuit signature and the random number generation). Investigation of this problem may lead to a very general and efficient way to test very large digital systems.

## APPENDIX I

Probability that a random sequence of length T contains a given subsequence of length  $\ell$ .

This is a well known problem whose general solution is extremely complex. However, for our purposes, one can get a simple approximation. Let us assume: all the letters of the alphabet (all possible inputs) have the same likelihood (with probability  $a = 2^{-n}$ ) and the given subsequence does repeat the same letter (each letter appears at most once).

Even though this seems to be a strong assumption, it gives a good approximation.

With these assumptions, we can model the process as a Markov chain. The state,  $S_i$  ( $i$  from 0 to  $\ell$ ) indicates that, while the random sequence is drawn, the last  $i$  letters correspond to the first  $i$  letters of the subsequence. The probability transition matrix,  $M$ , for this Markov chain is

$$M = \begin{bmatrix} 1-a, a, 0, \dots, 0 \\ 1-a, 0, a, \dots, 0 \\ 1-a, 0, 0, \dots, a \\ 0, 0, 0, \dots, 1 \end{bmatrix}$$

The characteristic polynomial is  $(\lambda-1) \frac{\lambda^{\ell+1} - \lambda^{\ell} - a^{\ell+1} + a^{\ell}}{\lambda - a}$ .

One of the eigenvalue is 1 and the one with the next higher absolute value is closely approximated by  $1 - (1-a)a^{\ell}$ . So the convergence radius is  $1 - (1-a) a^{\ell}$ . So,

Prob (to be in state  $S_\ell$  after  $T$  inputs) = Prob (the random sequence contains the given subsequence)

$$\approx 1 - \text{Exp} (-(1-a) a^\ell T) .$$

## VI. REFERENCES

- [Agrawal, P., et al., 1972] Agrawal, P. and V.D. Agrawal, "Probabilistic Analysis of Random Test Generation Method for Irredundant Combinational Logic Networks," IEEE Trans. on Computers, Vol. C-24, pp. 691-695, July 1975.
- [Agrawal, V.D., et al., 1972] Agrawal, V.D. and P. Agrawal, "An Automatic Test Generation System for ILLIAC IV Logic Boards," IEEE Trans. on Computers, Vol. C-21, pp. 1015-1017, September 1972.
- [Arbid, M.A., 1969] Arbid, M.A., Theories of Abstract Automata, Prentice-Hall, 1969.
- [Booth, T.L., 1967] Booth, T.L., Sequential Machines and Automata Theory, J. Wiley & Sons, New York, 1967.
- [Bouricius, W.G., et al., 1971] Bouricius, W.G., E.P. Hsieh, G.R. Putzolu, J.P. Roth, P.R. Schneider and C.J. Tan, "Algorithms for Detection of Faults in Logic Circuits," IEEE Trans. on Computers, Vol. C-20, pp. 1258-1264, November 1971.
- [Boute, R., 1972] Boute, R., "Algebraic Properties of Test Sequences and Fault Relations," Tech. Rpt. No. 37, Digital Systems Laboratory, Stanford University, Stanford, California, November 1972.
- [Breuer, M.A., 1971] Breuer, M.A., "A Random and an Algorithmic Technique for Fault Detection Test Generation for Sequential Circuits," IEEE Trans. on Computers, Vol. C-20, pp. 1364-1370, November 1971.
- [Hayes, J.P., 1975] Hayes, J.P., "Testing Logic Circuits by Transitions Counting," Proc. Fifth Int'l Symposium on Fault-Tolerant Computing, pp. 215-219, Paris, June 1975.
- [Hayes, J.P., 1976] Hayes, J.P., "Check Sum Test Methods," Proc. Sixth Int'l Symposium on Fault-Tolerant Computing, pp. 114-120, Pittsburg, June 1976.
- [Hayes, J.P., 1976] Hayes, J.P., "Transition Count Testing of Combinational Logic Circuits," IEEE Trans. on Computers, Vol. C-25, pp. 613-620, June 1976.

- [Losq, J., 1976] Los, J., "Referenceless Random Testing," Proc. Sixth Int'l Symposium on Fault-Tolerant Computing, pp. 108-113, Pittsburg, June 1976.
- [McCluskey, E.J., 1965] McCluskey, E.J., Introduction to the Theory of Switching Circuits, McGraw-Hill, New York, 1965.
- [McCluskey, E.J., et al., 1975] McCluskey, E.J. and K.P. Parker, "Boolean Networks Probabilities and Network Design," Tech. Note No. 60, Digital Systems Laboratory, Stanford University, Stanford, California, July 1975.
- [Parker, K.P., 1976] Parker, K.P., "Compact Testing: Testing with Compressed Data," Proc. Sixth Int'l Symposium on Fault-Tolerant Computing, pp. 93-98, Pittsburg, June 1976.
- [Parker, K.P., 1976] Parker, K.P., "Probabilistic Test Generation," Ph.D. Thesis, Digital Systems Laboratory, Stanford University, Stanford, California, May 1976.
- [Poage, J.P., et al., 1964] Poage, J.P. and E.J. McCluskey, "Derivation of Optimal Test Sequences for Sequential Machines," Proc. Fifth Annual Symposium on Switching Theory and Logical Design, pp. 121-132, 1964.
- [Rault, J.C., 1971] Rault, J.C., "A Graph Theoretical and Probabilistic Approach to the Fault Detection of Digital Circuits," Proc. First Int'l Symposium on Fault-Tolerant Computing, IEEE Computer Society Pub. 71C-G.C, pp. 26-29, March 1971.
- [Roth, J.P., et al., 1967] Roth, J.P., W.G. Bouricius and P.R. Schneider, "Programmed Algorithms to Compute Tests to Detect and Distinguish between Failures in Logic Circuits," IEEE Trans. on Electronic Computers, Vol. EC-16, pp. 567-580, October 1967.
- [Schnurmann, M.D., et al. 1975] Schnurmann, H.D., E. Lindbloom and R.G. Carpenter, "The Weighted Random Test-Pattern Generator," IEEE Trans on Computers, Vol. C-24, pp. 695-700, July 1975.

[Seller, F.F., et al.,  
1968]

Sellers, F.F., M.Y. Hsiao and L.W. Bearnson,  
"Analyzing Errors with the Boolean Difference,"  
IEEE Trans. on Computers, Vol. C-17, pp. 676-  
683, July 1968.

[Shedlestky, J.J., 1975]

Shedlestky, J.J., "A Rationale for the Random  
Testing of Combinational Digital Circuits,"  
Proc. CompCon 1975 Fall, pp. 5-8, September  
1975.

REPORT DOCUMENTATION PAGE		READ INSTRUCTIONS BEFORE COMPLETING FORM	
1. REPORT NUMBER Technical Note No. 104	2. GOVT ACCESSION NO. <b>14</b> DSL-7N-104	3. RECIPIENT'S CATALOG NUMBER	
4. TITLE (and Subtitle) <b>6</b> Efficiency of Compact Testing for Sequential Circuits,	5. TYPE OF REPORT & PERIOD COVERED <b>9</b> Technical Note,		
7. AUTHOR(s) <b>10</b> Jacques/Losq	6. PERFORMING ORG. REPORT NUMBER		
9. PERFORMING ORGANIZATION NAME AND ADDRESS Digital Systems Laboratory Stanford University Stanford, CA 94305	8. CONTRACT OR GRANT NUMBER(s) <b>15</b> <del>NSF</del> N00014-75-C-0601, NSF-MCS 76-05327		
11. CONTROLLING OFFICE NAME AND ADDRESS Sponsored Projects Office Stanford University Stanford, CA 94305	10. PROGRAM ELEMENT, PROJECT, TASK AREA & WORK UNIT NUMBERS 7151 and 7106	12. REPORT DATE <b>11</b> Dec <del>1976</del>	13. NO. OF PAGES <del>34</del>
14. MONITORING AGENCY NAME & ADDRESS (if diff. from Controlling Office) Stanford Electronics Laboratories Stanford University Stanford, CA 94305	15. SECURITY CLASS. (of this report) Unclassified <b>12</b> 36p.		
16. DISTRIBUTION STATEMENT (of this report)  This document has been approved for public release and sale; its distribution is unlimited.			
17. DISTRIBUTION STATEMENT (of the abstract entered in Block 20, if different from report)			
18. SUPPLEMENTARY NOTES			
19. KEY WORDS (Continue on reverse side if necessary and identify by block number)  detection sequential circuits failures synchronization random inputs testing			
20. ABSTRACT (Continue on reverse side if necessary and identify by block number)  Compact testing uses random inputs to test digital circuits. Detection is achieved by comparison between some statistic property of the circuit under test, like the frequency of ones on the output line, and the same property for the fault-free circuit. In this paper we show that compact testing can be used efficiently for sequential machines, although it has some inherent limitations. Synchronization is achieved by a long sequence of random inputs whose length is circuit dependent. However, for most sequential circuits, synchronization can be achieved in a few seconds. The great majority of failures inside the memory elements are easily detected			

408071

*J. Losq*

→ next page

20. Abstract (continued)

even with short tests. Compact testing also detects most of the failures in the combinational parts. There, its efficiency is largely dependent upon the test length and also the characteristics of the random number generators. However, even the most subtle failures may be detected if the test has sufficient length. Some of the requirements and trade-offs to achieve efficient detection are presented.

JSEP REPORTS DISTRIBUTION LIST

Department of Defense

Director  
National Security Agency  
Attn: Dr. T. J. Beahn  
Fort George G. Meade, MD 20755

Defense Documentation Center (12)  
Attn: DDC-TCA (Mrs. V. Caponio)  
Cameron Station  
Alexandria, VA 22314

Assistant Director  
Electronics and Computer Sciences  
Office of Director of Defense  
Research and Engineering  
The Pentagon  
Washington, D.C. 20315

Defense Advanced Research  
Projects Agency  
Attn: (Dr. R. Reynolds)  
1400 Wilson Boulevard  
Arlington, VA 22209

Department of the Army

Commandant  
US Army Air Defense School  
Attn: ATSAD-T-CSM  
Fort Bliss, TX 79916

Commander  
US Army Armament R&D Command  
Attn: DRSAR-RD  
Dover, NJ 07801

Commander  
US Army Ballistics Research Lab.  
Attn: DRXRD-BAD  
Aberdeen Proving Ground  
Aberdeen, MD 21005

Commandant  
US Army Command and  
General Staff College  
Attn: Acquisitions, Library Div.  
Fort Leavenworth, KS 66027

Commander  
US Army Communication Command  
Attn: CC-OPS-PD  
Fort Huachuca, AZ 85613

Commander  
US Army Materials and  
Mechanics Research Center  
Attn: Chief, Materials Sci. Div.  
Watertown, MA 02172

Commander  
US Army Materiel Development  
and Readiness Command  
Attn: Technical Lib., Rm. 7S 35  
5001 Eisenhower Avenue  
Alexandria, VA 22333

Commander  
US Army Missile R&D Command  
Attn: Chief, Document Section  
Redstone Arsenal, AL 35809

Commander  
US Army Satellite Communications  
Agency  
Fort Monmouth, NJ 07703

Director  
US Army Signals Warfare Laboratory  
Attn: DELSW-OS  
Arlington Hall Station  
Arlington, VA 22212

Project Manager  
ARTADS  
EAI Building  
West Long Branch, NJ 07764

NOTE: One (1) copy to each addressee unless otherwise indicated.

Commander/Director  
Atmospheric Sciences Lab. (ECOM)  
Attn: DRSEL-BL-DD  
White Sands Missile Range, NM 88002

Commander  
US Army Electronics Command  
Attn: DRSEL-NL-O  
(Dr. H. S. Bennett)  
Fort Monmouth, NJ 07703

Director  
TRI-TAC  
Attn: TT-AD (Mrs. Briller)  
Fort Monmouth, NJ 07703

Commander  
US Army Electronics Command  
Attn: DRSEL-CT-L (Dr. R. Buser)  
Fort Monmouth, NJ 07703

Director  
Electronic Warfare Lab. (ECOM)  
Attn: DRSEL-WL-MY  
White Sands Missile Range, NM 88002

Executive Secretary, TAC/JSEP  
US Army Research Office  
P. O. Box 12211  
Research Triangle Park, NC 27709

Commander  
Frankford Arsenal  
Deputy Director  
Pitman-Dunn Laboratory  
Philadelphia, PA 19137

Project Manager  
Ballistic Missile Defense  
Program Office  
Attn: DACS-DMP (Mr. A. Gold)  
1300 Wilson Boulevard  
Arlington, VA 22209

Commander  
Harry Diamond Laboratories  
Attn: Mr. John E. Rosenberg  
2800 Powder Mill Road  
Adelphi, MD 20783

HQDA (DAMA-ARZ-A)  
Washington, D.C. 20310

Commander  
US Army Electronics Command  
Attn: DRSEL-TL-E (Dr. J. A. Kohn)  
Fort Monmouth, NJ 07703

Commander  
US Army Electronics Command  
Attn: DRSEL-TL-EN  
(Dr. S. Kroenberg)  
Fort Monmouth, NJ 07703

Commander  
US Army Electronics Command  
Attn: DRSEL-NL-T (Mr. R. Kulinyi)  
Fort Monmouth, NJ 07703

Commander  
US Army Electronics Command  
Attn: DRSEL-NL-B (Dr. E. Lieblein)  
Fort Monmouth, NJ 07703

Commander  
US Army Electronics Command  
Attn: DRSEL-TL-MM (Mr. N. Lipetz)  
Fort Monmouth, NJ 07703

Commander  
US Army Electronics Command  
Attn: DRSEL-RD-O (Dr. W. S. McAfee)  
Fort Monmouth, NJ 07703

Director  
Night Vision Laboratory  
Attn: DRSEL-NV-D  
Fort Belvoir, VA 22060

Col. Robert Noce  
Senior Standardization Representative  
US Army Standardization Group, Canada  
Canadian Force Headquarters  
Ottawa, Ontario, Canada KIA )K2

Commander  
US Army Electronics Command  
Attn: DRSEL-NL-B (Dr. D. C. Pearce)  
Fort Monmouth, NJ 07703

Commander  
Picatinny Arsenal  
Attn: SMUPA-TS-T-S  
Dover, NJ 07801

Commander  
US Army Electronics Command  
Attn: DRSEL-NL-RH-1  
(Dr. F. Schwering)  
Fort Monmouth, NJ 07703

Commander  
US Army Electronics Command  
Attn: DRSEL-TL-I  
(Dr. C. G. Thornton)  
Fort Monmouth, NJ 07703

US Army Research Office (3)  
Attn: Library  
P. O. Box 12211  
Research Triangle Park, NC 27709

Director  
Division of Neuropsychiatry  
Walter Reed Army Institute  
of Research  
Washington, D.C. 20012

Commander  
White Sands Missile Range  
Attn: STEWS-ID-R  
White Sands Missile Range, NM 88002

Department of the Air Force

Mr. Robert Barrett  
RADC/ETS  
Hanscom AFB, MA 01731

Dr. Carl E. Baum  
AFWL (ES)  
Kirtland AFB, NM 87117

Dr. E. Champagne  
AFAL/DH  
Wright-Patterson AFB, OH 45433

Dr. R. P. Dolan  
RADC/ETSD  
Hanscom AFB, MA 01731

Mr. W. Edwards  
AFAL/TE  
Wright-Patterson AFB, OH 45433

Professor R. E. Fontana  
Head, Dept. of Electrical Engineering  
AFIT/ENE  
Wright-Patterson AFB, OH 45433

Dr. Alan Garscadden  
AFAPL/POD  
Wright-Patterson AFB, OH 45433

USAF European Office of  
Aerospace Research  
Attn: Major J. Gorrell  
Box 14, FPO, New York 09510

LTC Richard J. Gowen  
Department of Electrical Engineering  
USAF Academy, CO 80840

Mr. Murray Kesselman (ISCA)  
Rome Air Development Center  
Griffiss AFB, NY 13441

Dr. G. Knausenberger  
Air Force Member, TAC  
Air Force Office of Scientific  
Research, (AFSC) AFSOR/NE  
Bolling Air Force Base, DC 20332

Dr. L. Kravitz  
Air Force Member, TAC  
Air Force Office of Scientific  
Research, (AFSC) AFSOR/NE  
Bolling Air Force Base, DC 20332

Mr. R. D. Larson  
AFAL/DHR  
Wright-Patterson AFB, OH 45433

Dr. Richard B. Mack  
RADC/ETER  
Hanscom AFB, MA 01731

Mr. John Mottsmith (MCIT)  
HQ ESD (AFSC)  
Hanscom AFB, MA 01731

Dr. Richard Picard  
RADC/ETSL  
Hanscom AFB, MA 01731

Dr. J. Ryles  
Chief Scientist  
AFAL/CA  
Wright-Patterson AFB, OH 45433

Dr. Allan Schell  
RADC/ETE  
Hanscom AFB, MA 01731

Mr. H. E. Webb, Jr. (ISCP)  
Rome Air Development Center  
Griffiss AFB, NY 13441

LTC G. Wepfer  
Air Force Office of Scientific  
Research, (AFSC) AFOSR/NP  
Bolling Air Force Base, DC 20332

LTC G. McKemie  
Air Force Office of Scientific  
Research, (AFSC) AFOSR/NM  
Bolling Air Force Base, DC 20332

Department of the Navy

Dr. R. S. Allgaier  
Naval Surface Weapons Center  
Code WR-303  
White Oak  
Silver Spring, MD 20910

Naval Weapons Center  
Attn: Code 5515, H. F. Blazek  
China Lake, CA 93555

Dr. H. L. Blood  
Technical Director  
Naval Undersea Center  
San Diego, CA 95152

Naval Research Laboratory  
Attn: Code 5200, A. Brodzinsky  
4555 Overlook Avenue, SW  
Washington, D.C. 20375

Naval Research Laboratory  
Attn: Code 7701, J. D. Brown  
4555 Overlook Avenue, SW  
Washington, D.C. 20375

Naval Research Laboratory  
Attn: Code 5210, J. E. Davey  
4555 Overlook Avenue, SW  
Washington, D.C. 20375

Naval Research Laboratory  
Attn: Code 5460/5410, J. R. Davis  
4555 Overlook Avenue, SW  
Washington, D.C. 20375

Naval Ocean Systems Center  
Attn: Code 75, W. J. Dejka  
271 Catalina Boulevard  
San Diego, CA 92152

Naval Weapons Center  
Attn: Code 601, F. C. Essig  
China Lake, CA 93555

Naval Research Laboratory  
Attn: Code 5510, W. L. Faust  
4555 Overlook Avenue, SW  
Washington, D.C. 20375

Naval Research Laboratory  
Attn: Code 2627, Mrs. D. Folen  
4555 Overlook Avenue, SW  
Washington, D.C. 20375

Dr. Robert R. Fossum  
Dean of Research  
Naval Postgraduate School  
Monterey, CA 93940

Dr. G. G. Gould  
Technical Director  
Naval Coastal System Laboratory  
Panama City, FL 32401

Naval Ocean Systems Center  
Attn: Code 7203, V. E. Hildebrand  
271 Catalina Boulevard  
San Diego, CA 92152

Naval Ocean Systems Center  
Attn: Code 753, P. H. Johnson  
271 Catalina Boulevard  
San Diego, CA 92152

Donald E. Kirk  
Professor and Chairman  
Electronic Engineer, SP-304  
Naval Postgraduate School  
Monterey, CA 93940

Naval Air Development Center  
Attn: Code 01, Dr. R. K. Lobb  
Johnsville  
Warminster, PA 18974

Naval Research Laboratory  
Attn: Code 5270, B. D. McCombe  
4555 Overlook Avenue, SW  
Washington, D.C. 20375

Capt. R. B. Meeks  
Naval Sea Systems Command  
NC #3  
2531 Jefferson Davis Highway  
Arlington, VA 20362

Dr. H. J. Mueller  
Naval Air Systems Command  
Code 310  
JP #1  
1411 Jefferson Davis Highway  
Arlington, VA 20360

Dr. J. H. Mills, Jr.  
Naval Surface Weapons Center  
Electronics Systems Department  
Code DF  
Dahlgren, VA 22448

Naval Ocean Systems Center  
Attn: Code 702, H. T. Mortimer  
271 Catalina Boulevard  
San Diego, CA 92152

Naval Air Development Center  
Attn: Technical Library  
Johnsville  
Warminster, PA 18974

Naval Ocean Systems Center  
Attn: Technical Library  
271 Catalina Boulevard  
San Diego, CA 92152

Naval Research Laboratory  
Underwater Sound Reference Division  
Technical Library  
P. O. Box 8337  
Orlando, FL 32806

Naval Surface Weapons Center  
Attn: Technical Library  
Code DX-21  
Dahlgren, VA 22448

Naval Surface Weapons Center  
Attn: Technical Library  
Building 1-330, Code WX-40  
White Oak  
Silver Spring, MD 20910

Naval Training Equipment Center  
Attn: Technical Library  
Orlando, FL 32813

Naval Undersea Center  
Attn: Technical Library  
San Diego, CA 92152

Naval Underwater Systems Center  
Attn: Technical Library  
Newport, RI 02840

Office of Naval Research  
Electronic and Solid State  
Sciences Program (Code 427)  
800 North Quincy Street  
Arlington, VA 22217

Office of Naval Research  
Mathematics Program (Code 432)  
800 North Quincy Street  
Arlington, VA 22217

Office of Naval Research  
Naval Systems Division  
Code 220/221  
800 North Quincy Street  
Arlington, VA 22217

Director  
Office of Naval Research  
New York Area Office  
715 Broadway, 5th Floor  
New York, NY 10003

Office of Naval Research  
San Francisco Area Office  
One Hallidie Plaza, Suite 601  
San Francisco, CA 94102

Director  
Office of Naval Research  
Branch Office  
495 Summer Street  
Boston, MA 02210

Director  
Office of Naval Research  
Branch Office  
536 South Clark Street  
Chicago, IL 60605

Director  
Office of Naval Research  
Branch Office  
1030 East Green Street  
Pasadena, CA 91101

Mr. H. R. Riedl  
Naval Surface Weapons Center  
Code WR-34  
White Oak Laboratory  
Silver Spring, MD 20910

Naval Air Development Center  
Attn: Code 202, T. J. Shopple  
Johnsville  
Warminster, PA 18974

Naval Research Laboratory  
Attn: Code 5403, J. E. Shore  
4555 Overlook Avenue, SW  
Washington, D.C. 20375

A. L. Slafkovsky  
Scientific Advisor  
Headquarters Marine Corps  
MC-RD-1  
Arlington Annex  
Washington, D.C. 20380

Harris B. Stone  
Office of Research, Development,  
Test and Evaluation  
NOP-987  
The Pentagon, Room 5D760  
Washington, D.C. 20350

Mr. L. Sumney  
Naval Electronics Systems Command  
Code 3042, NC #1  
2511 Jefferson Davis Highway  
Arlington, VA 20360

David W. Taylor  
Naval Ship Research and  
Development Center  
Code 522.1  
Bethesda, MD 20084

Naval Research Laboratory  
Attn: Code 4105, Dr. S. Teitler  
4555 Overlook Avenue, SW  
Washington, D.C. 20375

Lt. Cdr. John Turner  
NAVMAT 0343  
CP #5, Room 1044  
2211 Jefferson Davis Highway  
Arlington, VA 20360

Naval Ocean Systems Center  
Attn: Code 746, H. H. Wieder  
271 Catalina Boulevard  
San Diego, CA 92152

Dr. W. A. Von Winkle  
Associate Technical Director  
for Technology  
Naval Underwater Systems Center  
New London, CT 06320

Dr. Gernot M. R. Winkler  
Director, Time Service  
US Naval Observatory  
Massachusetts Avenue at  
34th Street, NW  
Washington, D.C. 20390

Other Government Agencies

Dr. Howard W. Etzel  
Deputy Director  
Division of Materials Research  
National Science Foundation  
1800 G Street  
Washington, D.C. 20550

Mr. J. C. French  
National Bureau of Standards  
Electronics Technology Division  
Washington, D.C. 20234

Dr. Jay Harris  
Program Director  
Devices and Waves Program  
National Science Foundation  
1800 G Street  
Washington, D.C. 20550

Los Alamos Scientific Laboratory  
Attn: Reports Library  
P. O. Box 1663  
Los Alamos, NM 87544

Dr. Dean Mitchell  
Program Director  
Solid-State Physics  
Division of Materials Research  
National Science Foundation  
1800 G Street  
Washington, D.C. 20550

Mr. F. C. Schwenk, RD-T  
National Aeronautics and  
Space Administration  
Washington, D.C. 20546

M. Zane Thornton  
Deputy Director, Institute for  
Computer Sciences and Technology  
National Bureau of Standards  
Washington, D.C. 20234

Nongovernment Agencies

Director  
Columbia Radiation Laboratory  
Columbia University  
538 West 120th Street  
New York, NY 10027

Director  
Coordinated Science Laboratory  
University of Illinois  
Urbana, IL 61801

Director of Laboratories  
Division of Engineering and  
Applied Physics  
Harvard University  
Pierce Hall  
Cambridge, MA 02138

Director  
Electronics Research Center  
The University of Texas  
Engineering-Science Bldg. 112  
Austin, TX 78712

Director  
Electronics Research Laboratory  
University of California  
Berkeley, CA 94720

Director  
Electronics Sciences Laboratory  
University of Southern California  
Los Angeles, CA 90007

Director  
Microwave Research Institute  
Polytechnic Institute of New York  
333 Jay Street  
Brooklyn, NY 11201

Director  
Research Laboratory of Electronics  
Massachusetts Institute of Technology  
Cambridge, MA 02139

Director  
Stanford Electronics Laboratory  
Stanford University  
Stanford, CA 94305

Stanford Ginzton Laboratory  
Stanford University  
Stanford, CA 94305

Officer in Charge  
Carderock Laboratory  
Code 18 - G. H. Gleissner  
David Taylor Naval Ship Research  
and Development Center  
Bethesda, MD 20084

Dr. Roy F. Potter  
3868 Talbot Street  
San Diego, CA 92106