

AD-A049 942

PRINCETON UNIV N J DEPT OF AEROSPACE AND MECHANICAL--ETC F/0 19/1
PROPELLANT BURNING RATE AND COMBUSTION UNIFORMITY IDENTIFIED BY--ETC(U)
JAN 76 L H CAVENY, A J SABER, M SUMMERFIELD DAAA21-74-C-0332
AMS-1302 NL

UNCLASSIFIED

| OF |
AD
A049942



END
DATE
FILMED
3-78
DDC

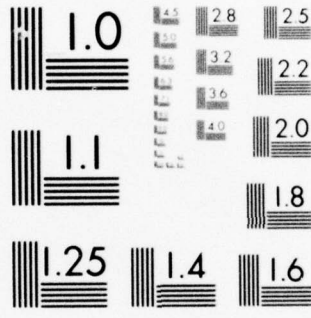

MICROCOPY RESOLUTION TEST CHART
NATIONAL BUREAU OF STANDARDS-1963-A

AD A 049942

AD No. _____
DDC FILE COPY

Princeton University

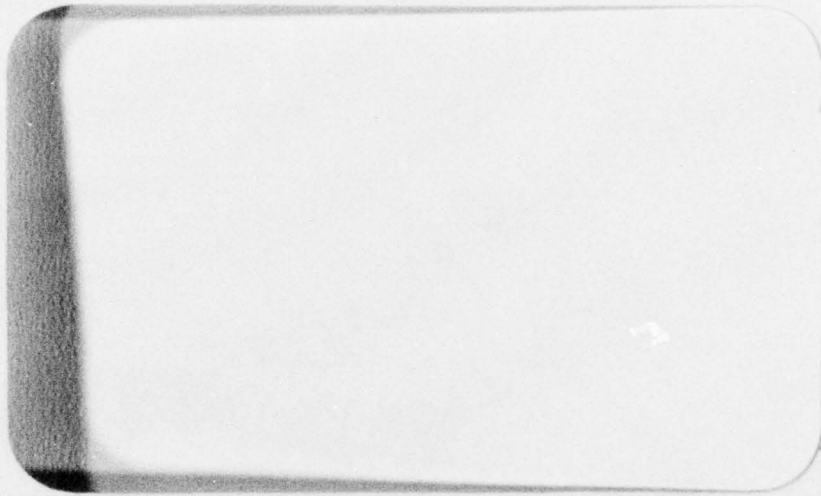

Department of
Aerospace and
Mechanical Sciences

DDC
RECEIVED
FEB 14 1978
D

DISTRIBUTION STATEMENT A
Approved for public release;
Distribution Unlimited

1

6 PROPELLANT BURNING RATE AND COMBUSTION
UNIFORMITY IDENTIFIED BY
ULTRASONIC ACOUSTIC EMISSIONS.

10 Prepared by
L. H. Caveny, A. J. Saber
M. Summerfield

11 January 1976

14 AMS 1392

15 DAAA 21-74-C-0332

13 48p

9 Final Report, 1 Mar 74 - 1 Aug 75

ACCESSION NO.	
NTIS	Write Section <input checked="" type="checkbox"/>
DDC	Ref Section <input type="checkbox"/>
UNANNOUNCED	<input type="checkbox"/>
JUSTIFICATION	
BY	
DISTRIBUTION/AVAILABILITY CODES	
Dist.	AVAIL. and/or SPECIAL
A	

Prepared for
Product Assurance Directorate
Picatinny Arsenal
Dover, New Jersey
Under Contract DAAA21-74-C-0332

DDC
RECEIVED
FEB 14 1978
D

Aerospace and Mechanical Sciences Department
Princeton University, Princeton, N.J.

DISTRIBUTION STATEMENT A
Approved for public release;
Distribution Unlimited

288475

JEK

UNCLASSIFIED

-ii-

SECURITY CLASSIFICATION OF THIS PAGE (When Data Entered)

REPORT DOCUMENTATION PAGE		READ INSTRUCTIONS BEFORE COMPLETING FORM
1. REPORT NUMBER	2. GOVT ACCESSION NO.	3. RECIPIENT'S CATALOG NUMBER AMS Report 1302 ✓
4. TITLE (and Subtitle) PROPELLANT BURNING RATE AND COMBUSTION UNIFORMITY IDENTIFIED BY ULTRASONIC ACOUSTIC EMISSIONS ✓		5. TYPE OF REPORT & PERIOD COVERED Final Report 1 Mar 1974 to 1 Aug 1975
7. AUTHOR(s) L. H. Caveny, A. J. Saber and M. Summerfield		6. PERFORMING ORG. REPORT NUMBER
9. PERFORMING ORGANIZATION NAME AND ADDRESS Princeton University Princeton, N.J. 08540 ✓		8. CONTRACT OR GRANT NUMBER(s) DAAA21-74-C-0332 <i>me</i>
11. CONTROLLING OFFICE NAME AND ADDRESS U.S. Army Picatinny Arsenal Dover, N.J. 07801 Attn: SARPA-WA-A-P		10. PROGRAM ELEMENT, PROJECT, TASK AREA & WORK UNIT NUMBERS
14. MONITORING AGENCY NAME & ADDRESS (if different from Controlling Office)		12. REPORT DATE January 1976 ✓
		13. NUMBER OF PAGES 47
		15. SECURITY CLASS. (of this report) UNCLASSIFIED
		15a. DECLASSIFICATION/DOWNGRADING SCHEDULE
16. DISTRIBUTION STATEMENT (of this Report) Approved for public release; distribution unlimited.		
17. DISTRIBUTION STATEMENT (of the abstract entered in Block 20, if different from Report)		
18. SUPPLEMENTARY NOTES		
19. KEY WORDS (Continue on reverse side if necessary and identify by block number) Solid Propellant Burning Rates. High Pressure Combustion. Acoustic Emission During Combustion. Single-Base Propellants. Double-Base Propellants.		
20. ABSTRACT (Continue on reverse side if necessary and identify by block number) A new method of measuring the burning rate of as-manufactured grains of nitrocellulose-based propellants was developed. Chamber pressurization to 50,000 psi (3400 atm) was achieved using a hydraulic pump, rather than a nitrogen intensifier system; the burning interval was monitored by recording the acoustic emission from the burning propellant. Burning rate variations of nitrocellulose-based propellants (M1 and M26), burning at pressures between 10,000 and 40,000 psi, were recognized by examining the level of the		

DD FORM 1 JAN 73 1473 EDITION OF 1 NOV 65 IS OBSOLETE

UNCLASSIFIED

SECURITY CLASSIFICATION OF THIS PAGE (When Data Entered)

SECURITY CLASSIFICATION OF THIS PAGE(When Data Entered)

20. Abstract - continued

combustion-generated acoustic emissions. Multi-perforated propellant grains were burned lengthwise (1 to 1.5 cm) and the RMS level of ultra-high frequency acoustic emissions were recorded. The burning rate variations of single-base propellants are attributed to incomplete dispersion of fibrous nitrocellulose. The double-base propellants produced neither irregularities in their acoustic emissions nor unusual variations in burning rate. These uniformities are attributed to the nitroglycerin which acts to disperse the nitrocellulose and to enhance burning rate.

Preface

This project conducted under U.S. Army Contract DAAA21-74-C-0332 and is part of the U.S. Army's Automated Continuous Acceptance Propellant (AUTOCAP) Project. The technical monitors were Messrs. F. J. Fitzsimmons, P. A. Serao and J. K. Domen of the Product Assurance Directorate (SARPA-QA-A-P). Their technical involvement significantly aided this project.

Table of Contents

	Page
Title Page	i
DD Form	
Preface	
Table of Contents	
List of Figures	
List of Tables	
1.0 INTRODUCTION	1
1.1 Burning Rate Measurements	1
1.2 Burning Rate Uniformity	2
2.0 TEST APPARATUS AND PROCEDURES	
2.1 Combustors	4
2.1.1 Intermediate Pressure Combustor	4
2.1.2 High Pressure Combustor	4
2.2 Instrumentation	8
2.3 Test Procedure	15
2.4 Other Burning Rate Determination Methods	16
2.4.1 Strand Burning Rate	16
2.4.2 Web Action Time (WAT)	16
2.4.3 Multiple Grain Web Action Time	18
3.0 RESULTS OF PROPELLANT STUDIES	19
3.1 Burning Rate Measurements	19
3.2 Burning Rate Uniformity	28
4.0 CONCLUSIONS	36
References	38

List of Figures

	Page
Fig. 2-1 The intermediate pressure combustor system. The combustor cell is pressurized with water using a hand pump. The propellant grain is then ignited and its acoustic output in the UHFAE range is sensed by an acoustic emissions transducer. The pressure in the combustor is kept constant using the nitrogen accumulator system shown. After the burn, spent water is exhausted and pressure is relieved by opening the blow-down valve.	5
Fig. 2-2 Pictorial drawing of combustor that operates in intermediate range pressure. Burning occurs under liquid and burning interval is monitored by acoustic emission detector.	6
Fig. 2-3 The percussion primer ignition system shown here uses a standard shell primer. The primer is actuated by impulsively striking the firing pin.	7
Fig. 2-4 This high pressure combustion system uses a liquid for pressurization. The liquid is pressurized with an air operated pump and the pressure can be maintained constant by using the accumulator. This system operates at pressures up to 4700 atm.	9
Fig. 2-5a Schematic drawing of combustor system showing arrangement of igniter, propellant sample, and acoustic emission detector.	10
Fig. 2-5b Configuration of high pressure vessel showing overall dimensions.	11
Fig. 2-6 Photographs of high pressure combustion apparatus developed at Princeton University as part of AUTOCAP.	12
Fig. 2-7 The propellant sample under test, shown here as a single M-6 grain, is enclosed in a graphite capsule and rests on a wire screen. The sample is ignited electrically using a nichrome igniter and a charge of nitrocellulose shavings stored in the primer. The graphite capsule has a nozzle that aids the flow of hot primer gases around the grain as well as through the perforations.	13

List of Figures - Continued

Fig. 2-8	Instrumentation used to measure burning time interval and acoustic emissions.	14
Fig. 2-9	The four means of measuring burning rate.	17
Fig. 3-1	Comparison of single base and double base burning rate data. (Tests which exhibited A.E. blasts are not included in mean.)	25
Fig. 3-2	Comparison of two lots of single base propellant showing that the extremes of the burning rate variabilities are similar. (Tests which exhibited A.E. blasts are not included in mean.)	26
Fig. 3-3	Comparison of burning rates measured at Princeton from as-manufactured grains and at Feltman Laboratories from specially manufactured strands.	27
Fig. 3-4	Example of high level of acoustic irregularity and the corresponding uneven burnout as indicated by the lack of sharp pressure peak.	30
Fig. 3-5	Example of very regular acoustic emission and the corresponding sharp burnout.	31
Fig. 3-6	Very low acoustic emissions from double-base propellant M26. Pressure 680 atm.	32
Fig. 3-7	Extinguished grains (burned as end burners) reveals that a particular single base propellant (M1) burns very nonuniformly compared to a double base propellant (M26).	33
Fig. 3-8	Acoustic emission data indicates that burning rate increases abnormally during period of A.E. blasts.	35

List of Tables

	Page
Table 3-1 Propellants Used in Experiments	20
Table 3-2 Tabulation of Burning Rate Data for M1 Lot U	21
Table 3-3 Tabulation of Burning Rate Data for M1 Lot P	22
Table 3-4 Tabulation of Burning Rate Data for M-26	23
Table 3-5 Burning Rate Pressure Sensitivity	24

1.0 INTRODUCTION

Accurate burning rate determinations and identification of nonuniformly burning propellants are essential to the characterization and quality control of solid propellants.¹ However, the test procedures currently employed to provide measured burning rates are cumbersome to implement and at high pressures (> 10,000 psi, 670 atm) do not yield sufficient information to resolve the significant variations in the burning of individual grains which result from small changes in propellant formulation, anticipated variations in processing procedures, and changes in raw material lots. Indeed, even in the intermediate pressure range (~ 2000 psi, 135 atm) where there may be sufficient data, accurate burning rate measurements require careful attention. Prior to this study, there were no systematic means of identifying out-of-specification burning rates and nonuniform burning of solid propellants other than examination of pressure versus time data and statistical analysis of individual burning rate measurements. Since the length of the individual grains are small (e.g., 1 to 2 cm), the conventional methods of using fuse wires to time burning intervals are extremely difficult to implement.

1.1 Burning Rate Measurements

Improvements in burning rate measurement techniques are required since they will permit in-process control using burning rates obtained from single grains taken directly from the production line. These more accurate measurements are also essential in the development and application of mathematical models of the combustion process.

The primary purpose of this project, therefore, was to develop techniques for obtaining accurate and detailed measurements of solid propellant burning rate. In particular, the project was directed at advancing the technology used to measure the burning rates of single base propellants in the 10,000 to 50,000 psi range (670 to 3400 atm). This effort departed

from both the conventional methods of chamber pressurization and burning interval measurement. Chamber pressurization to 50,000 psi (3400 atm) was achieved by using a hydraulic pump, rather than the expensive and temperamental nitrogen intensifier systems; the burning interval was monitored automatically by timing the period of acoustic emission from the burning propellant, rather than by fuse wire schemes which are unsatisfactory for small propellant specimens. Furthermore, an important advantage in the acoustic technique under development lies in its ability to detect nonuniform burning and to measure the burning rates of propellant grains (sampled during various stages of a production run) so that compliance with specified standards can be determined in time to adjust the processing procedures and formulation.

1.2 Burning Rate Uniformity

Also as part of this project, a technique was demonstrated for recognizing localized and intermittent variations in burning rate, i.e., burning rate variations occurring in regions as small as 0.5 mm and over time intervals of a few milliseconds. The diagnostic technique is capable of recognizing burning rate variations and nonuniformities that occur in individual grains of nitrocellulose-based propellants. Average burning rate variations are traditionally recognized from burning rate versus pressure data (i.e., r vs p) obtained by burning long strands or from detailed analysis of closed-chamber pressure versus time records. However, these methods seldom give clues as to why the burning rate deviates from a standard. Furthermore, it is not uncommon to experience increases in the standard deviations of ignition times, operating pressures, and other performance parameters which cannot be related easily to any particular average burning rate measurement.

The value of nonuniform burning determination is immediate. For example, the results show that propellants with short, localized burning rate variations have proportionally larger

average burning rate standard deviations; these larger deviations (which would be masked in long strand data) may be symptomatic of unacceptably large deviations in ballistic performance. As another example, the technique has utility as a process control tool which enables the process engineer to locate the source of burning variations; short, localized burning rate variations may be symptomatic of problems such as incomplete mixing, porosity, and irreproducible flow alignment during extrusion or casting. As part of a follow-on study, the technique is being refined and evaluated for use as part of the on-line quality control of multi-base propellants manufactured by modernized processes.¹ In that application, the propellants may be tested immediately after the grain extrusion step; thus, process corrections can be made within a relatively short time interval.

2.0 TEST APPARATUS AND PROCEDURES

2.1 Combustors

Two combustors were designed and fabricated as part of this project for use with the acoustic emission instrumentation. The first combustor is for intermediate pressure [to 2000 psi (135 atm)] and was used to check the acoustic emission instrumentation and to evaluate the pressurization concepts used in the high-pressure combustor. The second combustor is for high pressure [$> 50,000$ psi (3400 atm)] and was used extensively in this project to measure burning rates at high pressure.

2.1.1 Intermediate Pressure Combustor

The intermediate pressure combustor shown in Figs. 2-1 and 2-2 uses a stainless steel pressure chamber which is filled with liquid (usually water) and pressurized to a predetermined level (up to 135 atm) with a hand-operated pump. The pressure is maintained constant with a nitrogen accumulator. As the propellant burns, its combustion UHFAE is sensed by a piezoelectric acoustic transducer mounted on the side of the combustor and the combustor pressure is sensed by a piezoelectric pressure transducer.

Ignition in the intermediate pressure system is accomplished with either an electric hot-wire igniter or a percussion primer. The primer ignition method is implemented as shown on Fig. 2-3; the combustor head contains the primer, the firing pin, grain holder, retaining ring, and a seal to maintain pressure. The firing pin is struck to activate the primer that in turn ignites the propellant sample. The hot-wire ignition was satisfactory for most applications. The electrical connection for the hot-wire igniter is passed through the combustor cap.

2.1.2 High Pressure Combustor

The major components of the high-pressure (up to 50,000 psi) apparatus are the heavy-walled combustor and an air-actuated high-pressure hydraulic pump. The arrangement of the

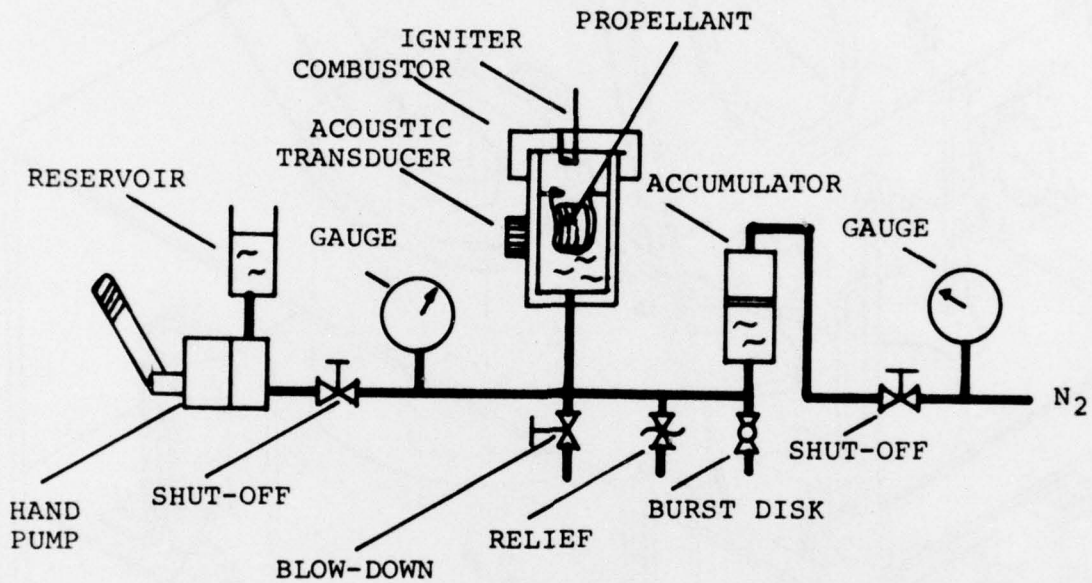

Fig. 2-1 The intermediate pressure combustor system
The combustor cell is pressurized with water using a hand pump. The propellant grain is then ignited and its acoustic output in the UHFAE range is sensed by an acoustic emissions transducer. The pressure in the combustor is kept constant using the nitrogen accumulator system shown. After the burn, spent water is exhausted and pressure is relieved by opening the blow-down valve.

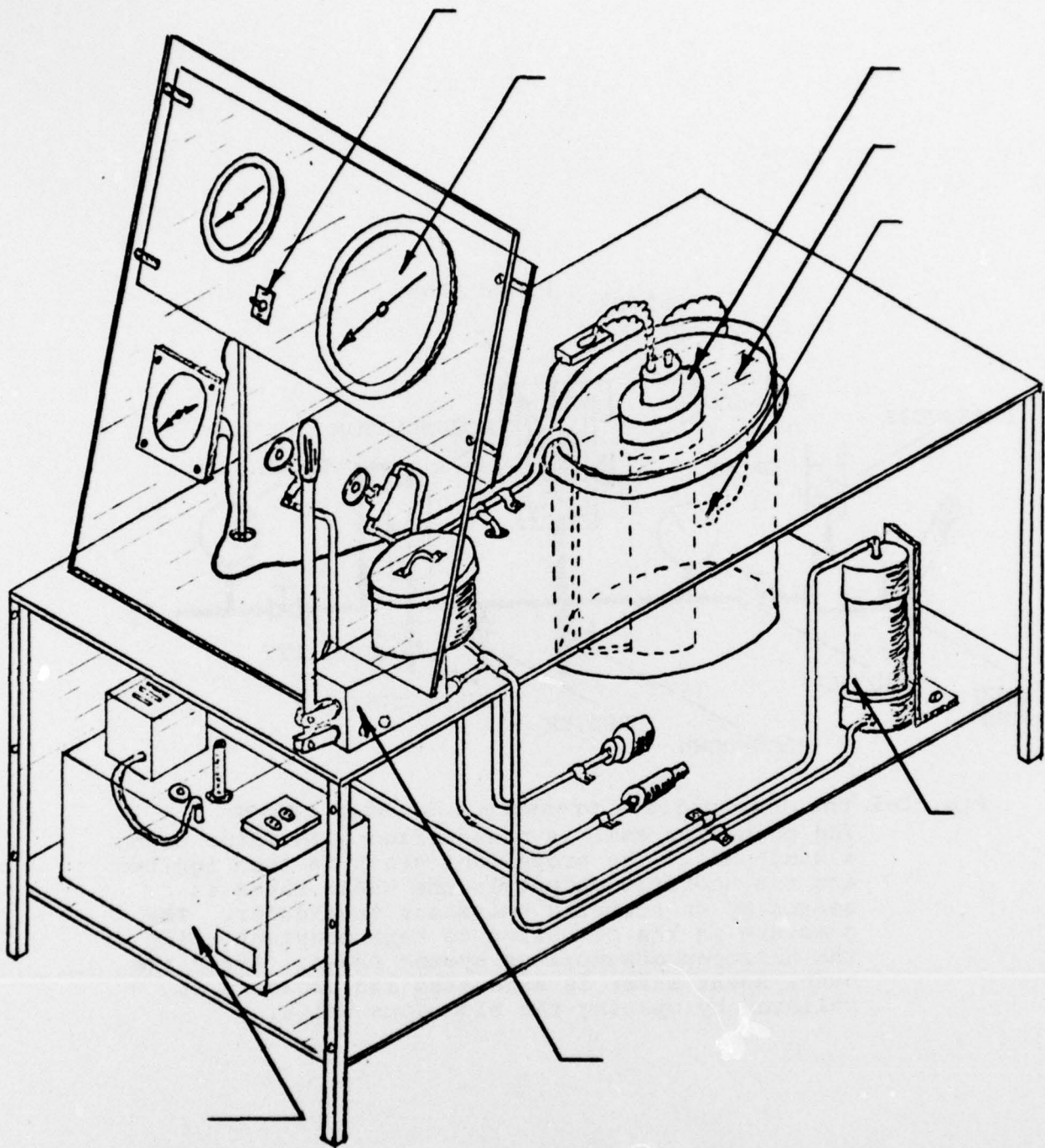

Fig. 2-2 Pictorial drawing of combustor that operates in intermediate range pressure. Burning occurs under liquid and burning interval is monitored by acoustic emission detector.

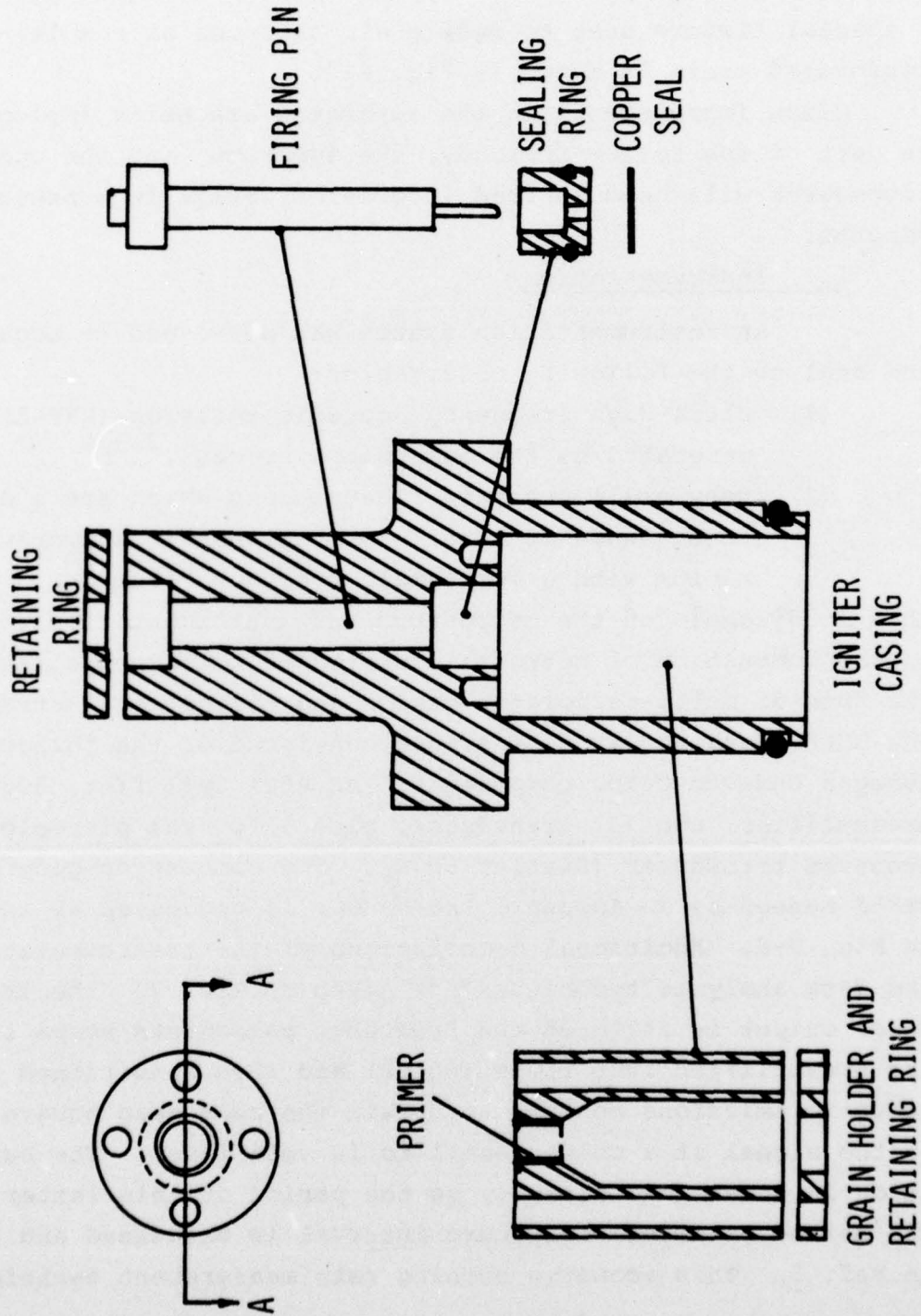

Fig. 2-3 The percussion primer ignition system shown here uses a standard shell primer. The primer is actuated by impulsively striking the firing pin.

components is shown in Fig. 2-4. The heavy-walled combustor with a single grain and hot-wire igniter in position is shown in Fig. 2-5a. The dimensions of the combustor are shown in Fig. 5b. Photographs of the apparatus are shown in Fig. 2-6. A special fixture used to ignite all surfaces of a multi-perforated grain is shown in Fig. 2-7.

Since improvements in the apparatus are being implemented as part of the follow-on study, the apparatus and the operating procedures will be described in greater detail in subsequent reports.

2.2 Instrumentation

An instrumentation system was developed to acquire and analyze the following observables:

- (1) ultra-high frequency acoustic emission (UHFAE) generated by the combustion process.^{2,3,4}
- (2) very small pressure fluctuations which are a direct consequence of burning propellants in a hydraulic medium with a very small free gas volume.

This study employed the combustors and instrumentation to focus on the combustion of nitrocellulose-based solid propellants in the form of multi-perforated grains and conventional strands. The UHFAE data acquisition system consisted of the following Dunegan Endevco Corp. components: AE 4001 amplifier, 802P-A preamplifier, and 731 transducer, plus a 100 kHz piezoelectric pressure transducer (Kistler 607A). The combustion-generated UHFAE sensed by an acoustic transducer is processed as shown in Fig. 2-8. Additional descriptions of the instrumentation and data analysis techniques are given in Ref. 2. The transducer output is filtered and frequency components above 100 kHz are preamplified 1000 times (60 dB) and then conditioned in an acoustic emissions monitor to obtain the root mean square (RMS) of the signal at a convenient 1 to 10 volt level. The burn duration is determined directly as the period of this latter signal. The method of determining burn interval is discussed and analyzed in Ref. 5. This acoustic burning rate measurement technique

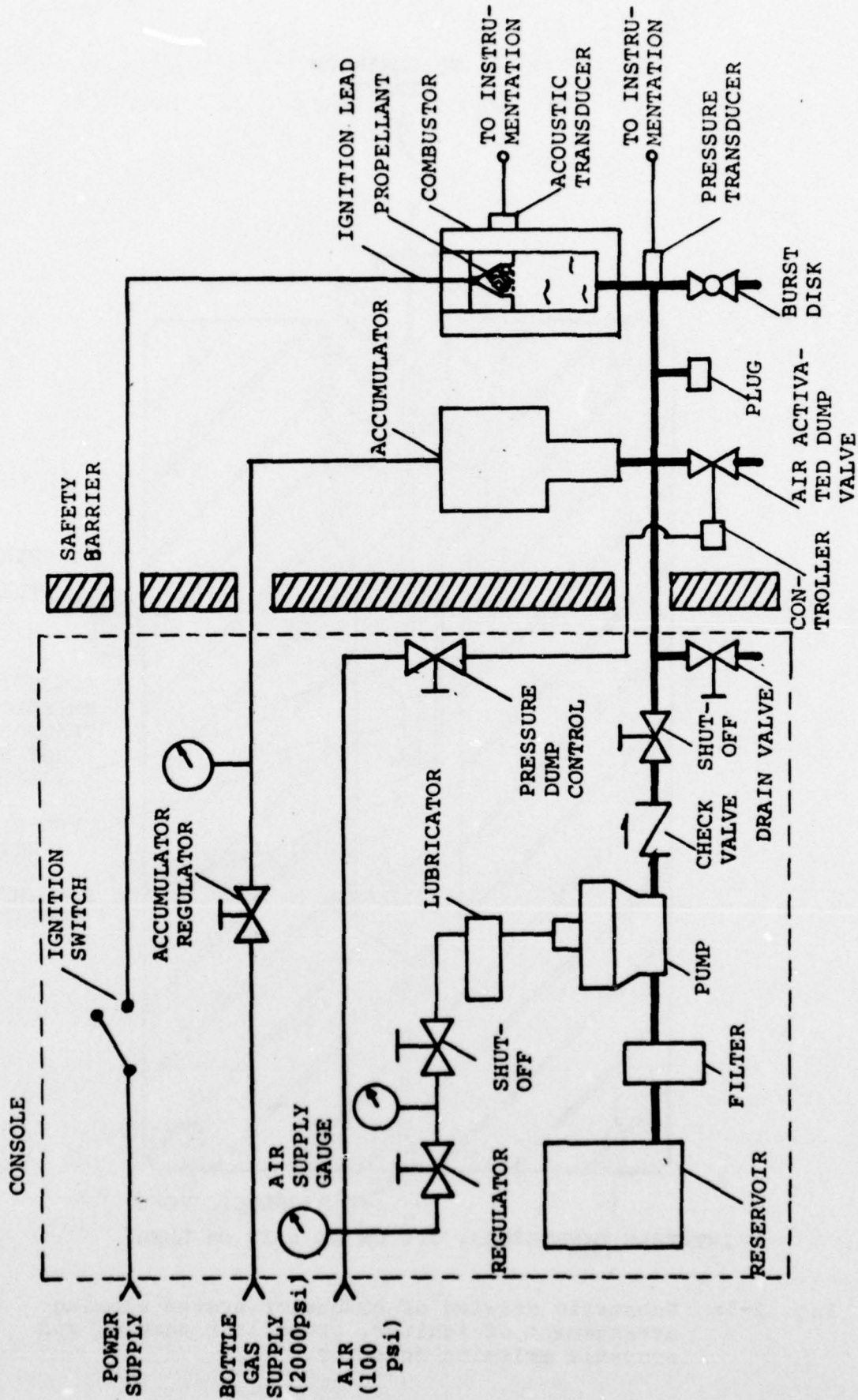
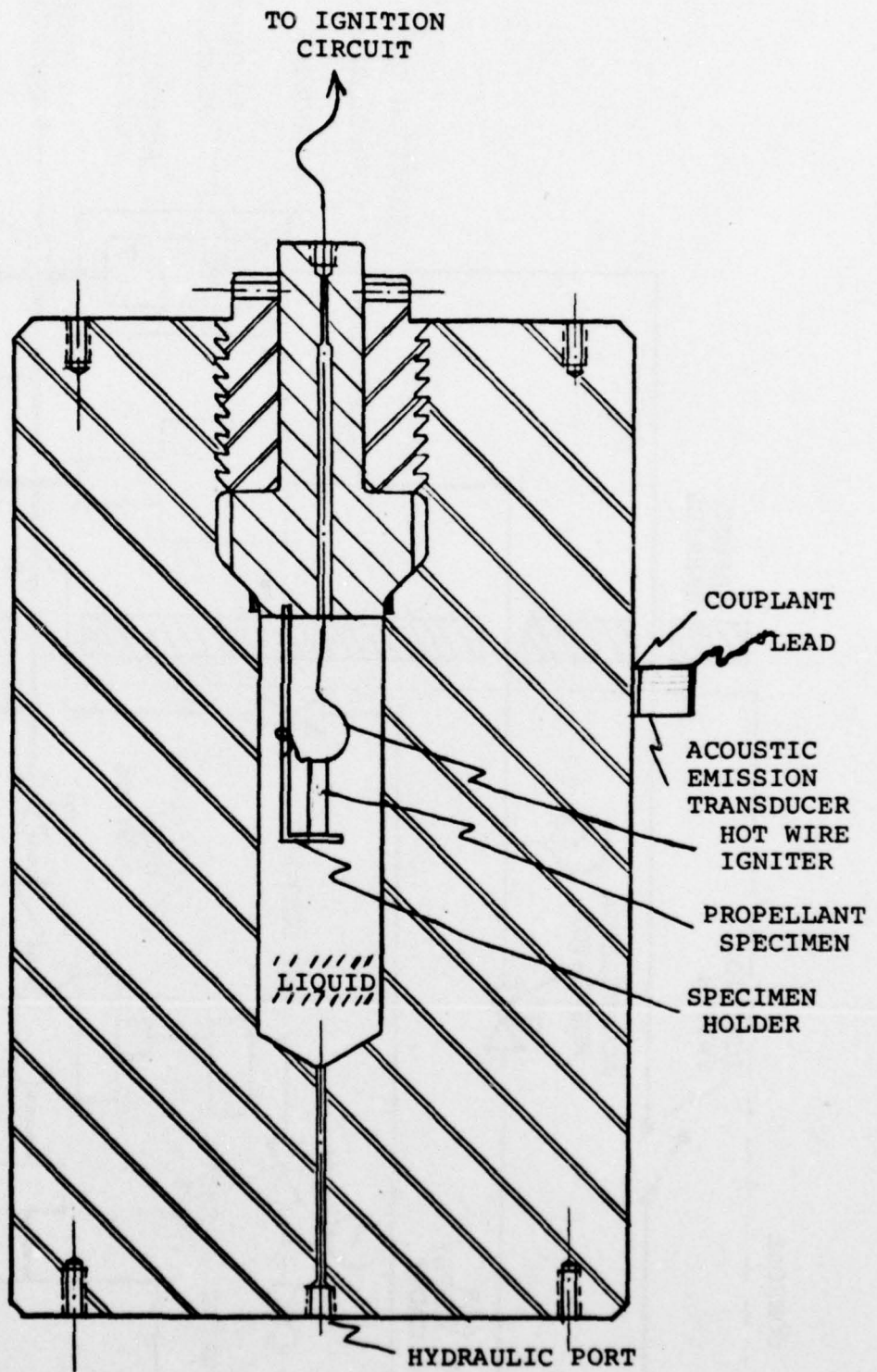

Fig. 2-4 This high pressure combustion system uses a liquid for pressurization. The liquid is pressurized with an air operated pump and the pressure can be maintained constant by using the accumulator. This system operates at pressures up to 4700 atm.



INTERNAL DIMENSIONS: 7.5 CM OD & 23 cm LONG

Fig. 2-5a Schematic drawing of combustor system showing arrangement of igniter, propellant sample, and acoustic emission detector.

SCALE = 1 to 4

OPERATING PRESSURE: 50,000 PSI

DESIGN PRESSURE: 100,000 PSI

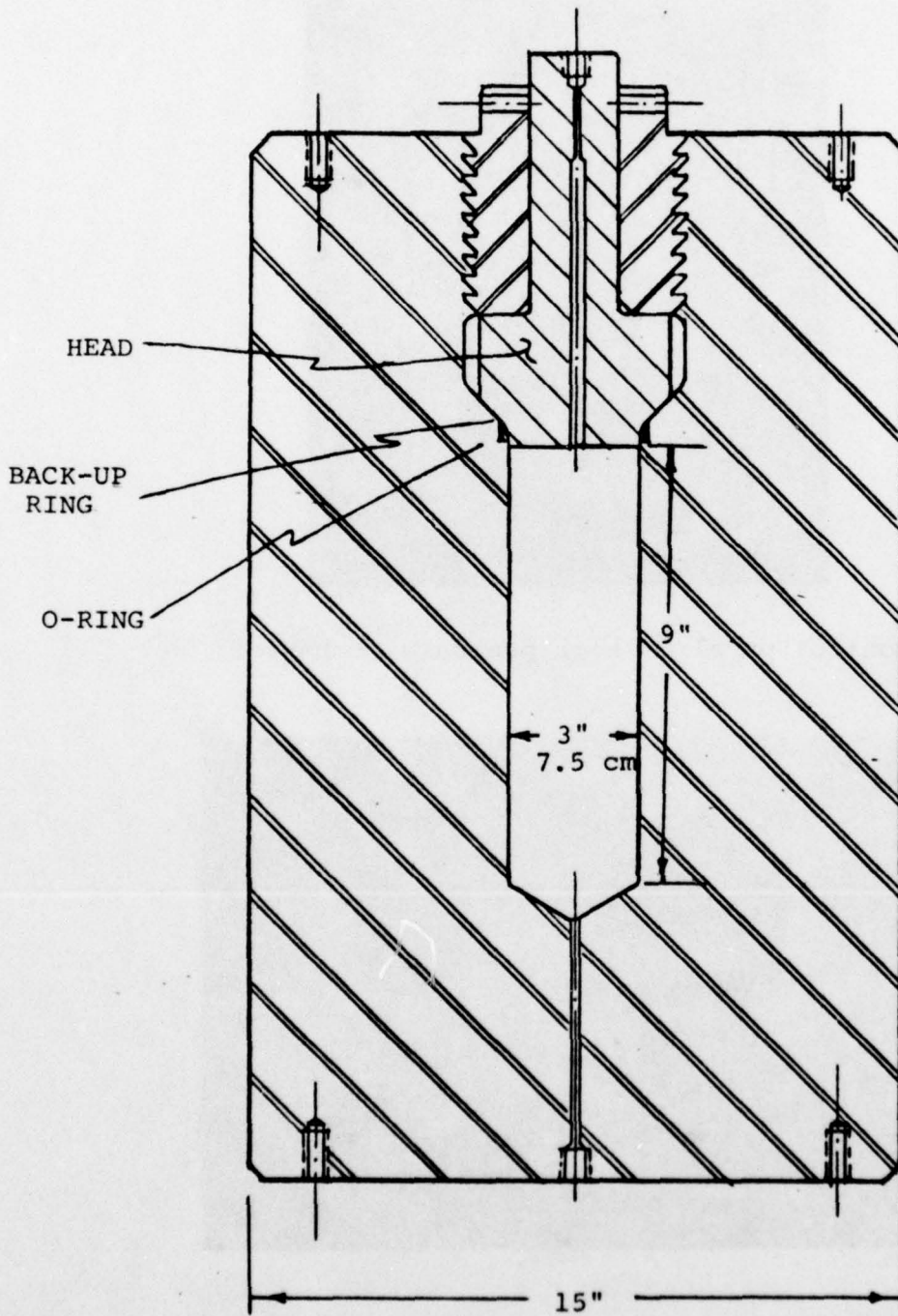
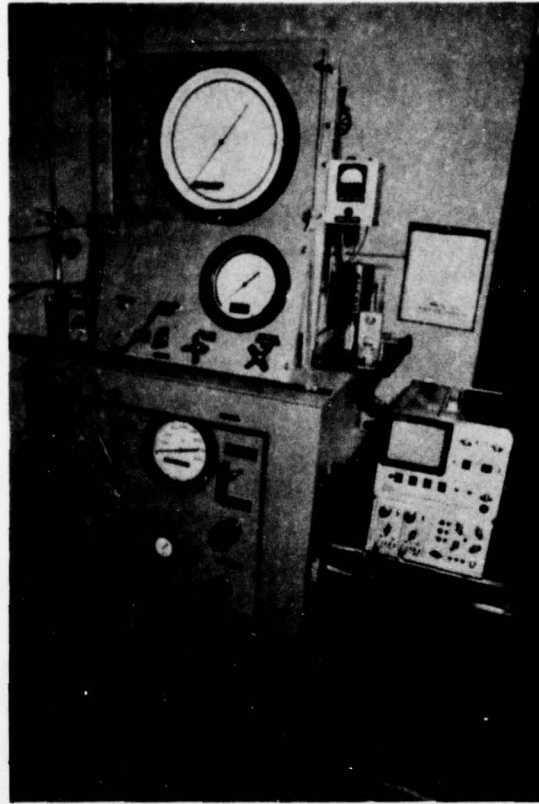
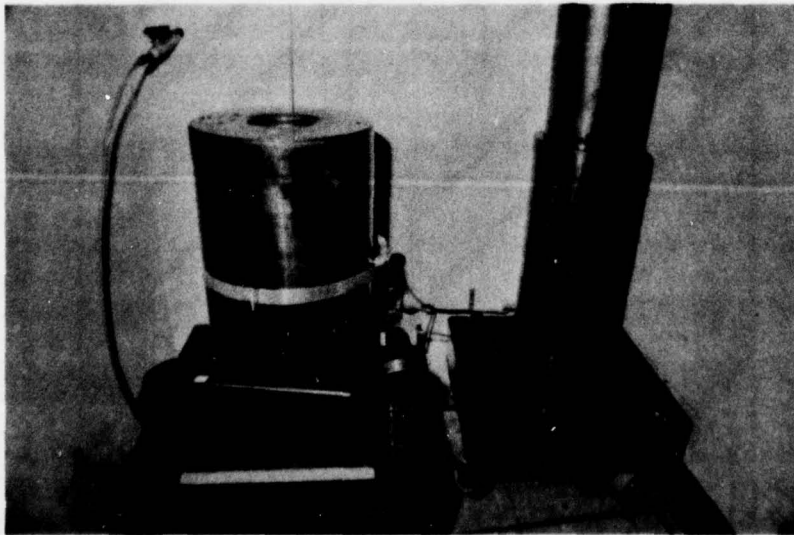

Fig. 2-5b Configuration of high pressure vessel showing overall dimensions.



Control panel of high pressure combustor



Combustor (on left), accumulator (on right) and strand holder (in foreground)

Fig. 2-6 Photographs of high pressure combustion apparatus developed at Princeton University as part of AUTOCAP.

HIGH PRESSURE WAT GRAIN HOLDER

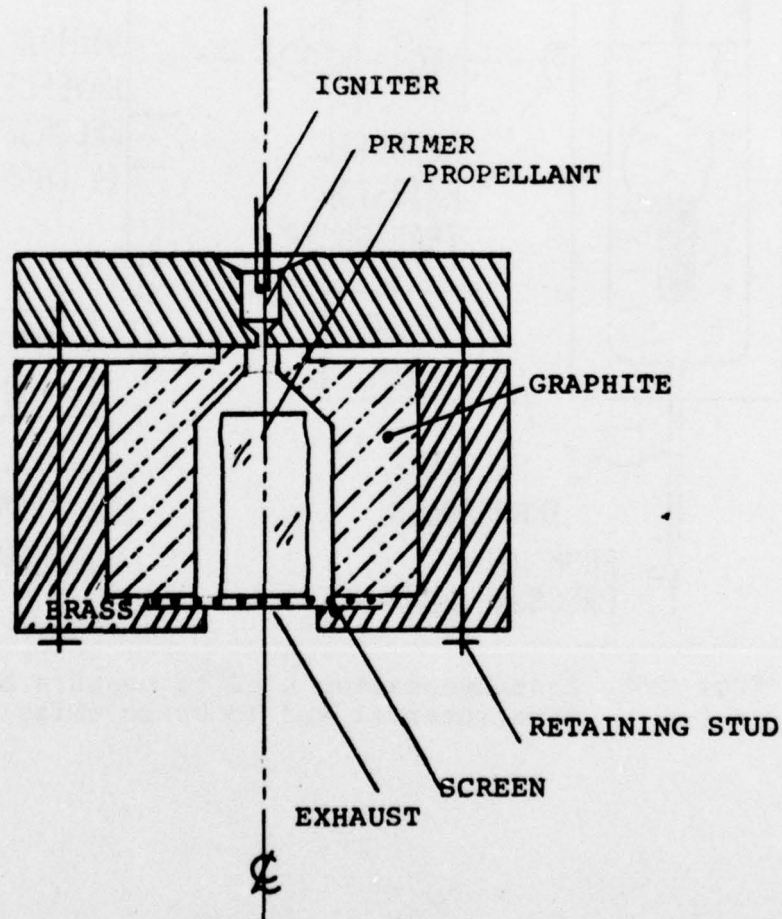

Fig. 2-7

The propellant sample under test, shown here as a single M-6 grain, is enclosed in a graphite capsule and rests on a wire screen. The sample is ignited electrically using a nichrome igniter and a charge of nitrocellulose shavings stored in the primer. The graphite capsule has a nozzle that aids the flow of hot primer gases around the grain as well as through the perforations.

INSTRUMENTATION

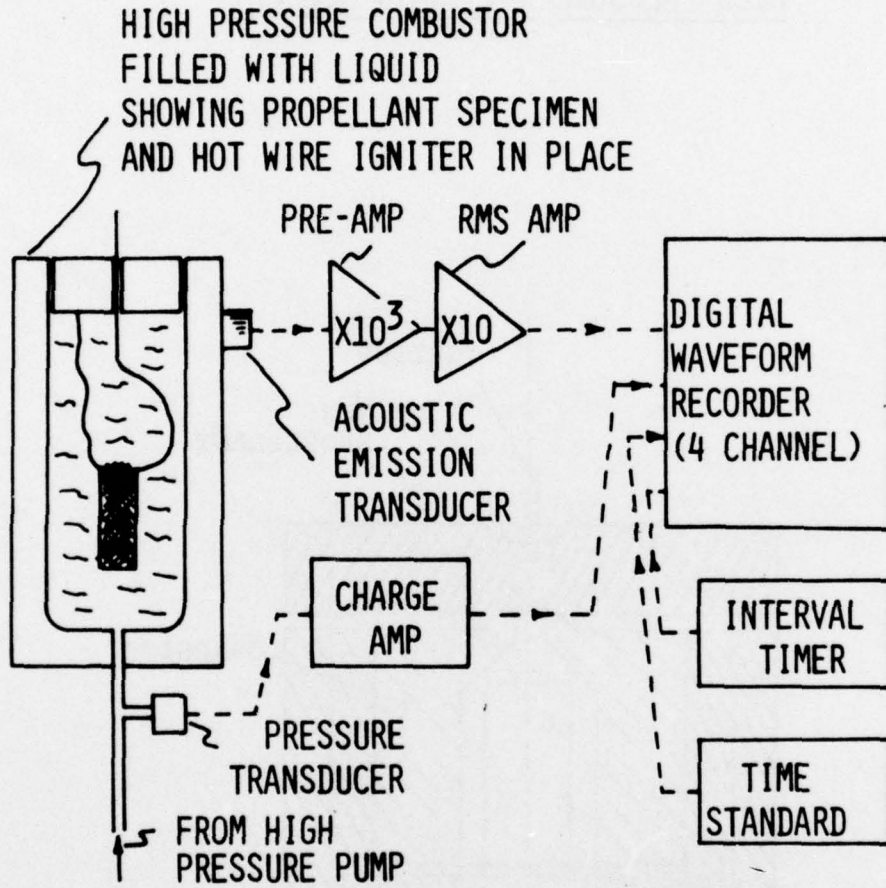

Fig. 2-8 Instrumentation used to measure burning time interval and acoustic emissions.

eliminates the drilling of holes for breakwires and precludes propellant contact with anything but the burn medium.

The UHFAE signals are stored in a digital waveform recorder (Biomation 1015) capable of sampling the conditioned data at rates as fast as 0.01 msec. These data are accompanied by the pressure history of the combustor (i.e., total pressure rises are typically 1 to 4%) and the output of a time-mark generator used as a time reference to accurately determine the burning interval.

2.3 Test Procedure

One of the goals of this study was to make direct determinations of the burning rates of as-manufactured propellants, which in this case were propellant grains with seven perforations and outside diameters ranging from 0.6 to 1.5 cm and lengths ranging from 1.0 to 2.0 cm. Accordingly, the grains were burned lengthwise as strands. To prepare the test specimens, individual grains were trimmed square and measured to within ± 0.005 cm. Then, a flattened nichrome-wire igniter in zig-zag form was mounted on one end of the strand with a smear of acetone-based cement. Finally, to promote uniform flame spreading across the surface, a thin (0.05 cm) cardboard disk was held lightly against the nichrome wire.

The strand and its mount assembly were installed in the combustor which had been pre-filled with tap water of controlled temperature and the system was pressurized to the desired pressure. To avoid questions concerning the immersion time, ignition was programmed to occur three minutes after the propellant was first immersed.

In many cases, the liquid medium effectively prevented flame spreading along the side of the propellant strands. However, in the experiments discussed here, the grains were inhibited to eliminate all questions concerning flame spreading into the perforations.

Previous studies^{3,6} have demonstrated that when the experiment is properly designed, burning in a liquid medium does not affect burning rate. High-speed photographs reveal that the combustion gases issuing from the burning surface form a gaseous atmosphere above the burning strand which prevents the surrounding liquid from coming into contact with the burning surface. However, if either the pressure is sufficiently low or the cross-sectional dimensions of the strand are sufficiently small, the momentum of the gases issuing from the burning surface will be too low to exclude the surrounding liquid. (For more details, see Ref. 5.)

2.4 Other Burning Rate Determination Methods

Three burning rate determination methods in addition to the method described in Section 2.3 are illustrated in Fig. 2-9. The three other methods are summarized briefly in the following subsections.

2.4.1 Strand Burning Rate

A strand of propellant is cut to a convenient length, drilled for a hot-wire igniter, and measured. A nichrome-wire igniter is passed through the hole, the strand is mounted on a plastic base, and the igniter leads are connected to terminals. The remaining steps are the same as described in Section 2.3 and in Ref. 5.

2.4.2 Web Action Time (WAT)

To measure their WAT in a high-pressure gaseous atmosphere, propellant grains are installed in a grain holder shown in Fig. 2-7. The holder consists of an inner crucible fabricated from graphite with a port at one end and an orifice machined in the other. The base is a wire screen used to prevent propellant grains from falling into the combustor fluid during ignition. The nozzle end of the crucible is butted against an igniter assembly which consists of a nitrocellulose propellant primer ignited with a coil of nichrome wire. The igniter engulfs the propellant grain in flame for the purpose of achieving uniform ignition over all of the propellant surfaces.

MEANS OF MEASURING BURNING RATE VARIABILITY

LONG STRANDS
EXTRUDED FROM
PRODUCTION RUN
(SPECIAL SPECIMEN)

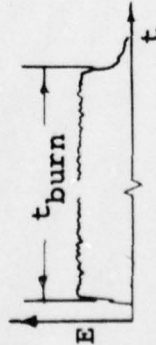
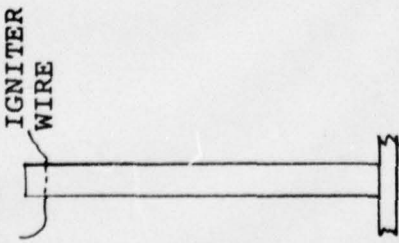

ADVANTAGES:
IF PROPELLANT IS
HOMOGENEOUS, SHOULD
PRODUCE THE MOST
ACCURATE DATA.

INDIVIDUAL GRAIN
(WITH CENTER PERFS
INHIBITED) BURNED
AS END BURNER

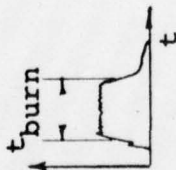

WORKS WITH GRAINS
OFF THE LINE AND
LENGTH IS SUFFI-
ICIENT TO GET
REASONABLE
ACCURACY.

INDIVIDUAL GRAIN
BURNED ON ALL
SURFACES TO GET
WEB ACTION TIME

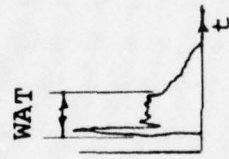
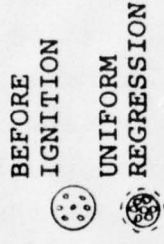

BURNING IS VERY
SIMILAR TO CON-
DITIONS EXPERI-
ENCED IN
PRACTICE.

SEVERAL GRAINS BURNED
TO GET AVERAGED WEB
ACTION TIME

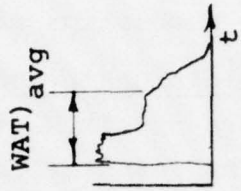
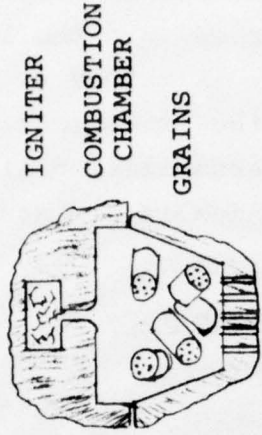

GRAIN-TO-GRAIN VARI-
ATIONS ARE AVERAGED.

Fig. 2-9 The four means of measuring burning rate.

To make a run, the combustor is pre-filled with helium (an inert gas that is not readily absorbed into the liquid) to 68 atm (1000 psi); then the pressure is raised to the desired operating conditions. During the experiment the grain does not come into contact with the pressurization liquid, rather, it remains in the atmosphere which is a mixture of compressed helium and combustion gases.

2.4.3 Multiple Grain Web Action Time

Clusters of six M1 grains can be burned in the WAT configuration. The results are compared to those for single grains. During the design of the experiment, the emphasis was on obtaining extremely rapid and uniform ignition. At the present stage of development, the WAT experiments resulted in relatively large test-to-test variations in measured burning rate. The difficulties are being attributed to the slow flame spreading in the perforations and variation in the dimensional stability of the perforations in the grains.

3.0 RESULTS OF PROPELLANT STUDIES

3.1 Burning Rate Measurements

The burning rate properties of the propellants listed in Table 3-1 were studied. Nitrocellulose (NC) is the primary ingredient in all of the propellants. The Lot U M1 propellant has a higher K_2SO_4 and entrained water content than the Lot P M1 propellant.

The fibrous NC used in the M1 propellants becomes tangled and causes discontinuities (with dimensions on the order of one millimeter). Those regions in which the tangles of fibrous NC have not been dispersed have relatively small concentrations of the other propellant ingredients; all of the other ingredients act to suppress burning rate and energy level. It is well known that increasing the energy of NC-based propellants also increases their burning rates. Accordingly, it is reasonable to expect the discontinuous regions containing higher NC concentrations to have higher burning rates. The nitroglycerin which is added to increase energy also acts as a plasticizer and, thereby, tends to distribute the fibrous NC to make the propellant more homogeneous. Accordingly, M26 propellants appear to be much more uniform in composition than the M1 propellants.

The burning rates of the propellant grains burned as end-burners are shown in Figs. 3-1, 3-2 and 3-3. The range, number, and mean value at each test pressure are indicated on the figures. Tabulations of the data are given in Tables 3-2, 3-3, and 3-4. The variations in the M26 burning rates are less than those for M1. As shown in Fig. 3-2, the burning rate variations of propellant M1 Lot P are greater than those of propellant M1 Lot U.

The burning rate pressure sensitivities, n , obtained as part of this study are compared to two types of burning rate measurements obtained at the Feltman Laboratories of Picatinny Arsenal.⁷ As indicated on Table 3-5, the n values obtained at the Feltman Laboratories by burning long propellant strands in high-pressure N_2 are comparable to the results obtained during

Table 3-1
Propellants Used In Experiments

Percentage by Weight	Single Base M1		Double Base M26
	Lot U	Lot P	
Nitrocellulose ^a (13.15% nitration)	84.73	84.74	67.25
Nitroglycerin	-0-	-0-	25.0
Dinitrotoluene	9.97	9.65	
Barium nitrate			0.75
Potassium nitrate			0.70
Ethyl centralite			0.30 6.0
Dibutylphthalate	5.30	5.61	0.3
^{GRAPHITE} Diphenylamine	1.07 ^b	1.10 ^b	6.0
K ₂ SO ₄	2.10 ^b	0.62 ^b	

Total volatiles	2.67	0.95	
Residual Solvent	0.27	0.18	1.20
Water	2.40	0.77	0.3
Grain diameter, cm	0.60	0.60	0.60
Lot	RAD-PE- 441-U	RAD-PE- 441-P	RAD-65116

^a Wood sulfite cellulose

^b Added to basic propellant

Table 3-2
 Tabulation of Burning Rate Data for M1 Lot U

TEST	\bar{P} PSIG	\bar{I} CM/SEC	QUALITY OF PEAK FOR TANGENT	INDICATION* OF ABNORMAL BURNING	STATISTICAL PARAMETERS**
HP-127	10,203	4.670	10	A	With 128 excluded $\bar{I} = 4.77$
128	10,220	5.893	5	A P R	
129	10,208	4.866	8		
HP-100	20,173	7.422	10		With 104 & 106 excluded $\bar{I} = 9.18$ $S_{\bar{I}} = 0.230, \text{COV} = 2.5\%$ $S_{\bar{I}} = 0.094, \text{COV} = 1.0\%$
101	20,188	8.797	9		
102	20,183	9.341	9		
103	20,175	9.305	9		
104	20,176	10.126	8	A P R	
105	20,179	9.183	9	A	
106	20,162	14.756	5	A P R	
107	20,175	9.051	9	A	
HP-108	30,166	12.959	9		With 110 and 111 excluded $\bar{I} = 13.02$
109	30,165	13.072	10		
110	30,159	14.778	3	A P R	
111	30,177	18.072	5	A P R	
HP-120	40,176	17.341	10		$\bar{I} = 17.55$ $S_{\bar{I}} = 0.329, \text{COV} = 1.9\%$ $S_{\bar{I}} = 0.165, \text{COV} = 0.9\%$
121	40,181	17.673	10	A	
122	40,185	17.241	9	A	
123	40,176	17.964	9		

*A - indicates that acoustic emission is irregular, after ignition blast.

P - indicates that P_{max} peak reveals nonuniform burning.

R - indicates that burning time is unusually short.

**The data from the individual grains that experienced abnormal burning were not used to obtain the mean burning rate.

Table 3-3
 Tabulation of Burning Rate Data for M1 Lot P

TEST	\bar{P} PSIG	r CM/SEC	QUALITY OF PEAK FOR TANGENT	INDICATION OF ABNORMAL BURNING	STATISTICAL PARAMETERS
M1-P2A	10,307	5.534	8		$\bar{r} = 5.440$ $S_r = 0.071, \text{COV} = 1.3\%$
3A	10,318	5.448	9		
4A	10,615	5.412	9		
HP-131	10,215	5.367	10		With 115, 116 & 117 excluded $\bar{r} = 10.40$ $S_r = 0.697, \text{COV} = 6.7\%$ $S_{\bar{r}} = 0.312, \text{COV} = 3.0\%$
HP-112	20,177	10.169	8	A	
113	20,169	11.173	7	A	
114	20,165	9.353	7	A	
115	20,157	13.260	6	A P R	
116	20,170	11.776	3	A P R	
117	20,170	11.976	5	A P R	
118	20,167	10.840	7	A	
119	20,170	10.462	8	A	
HP-134	30,175	14.870	10	A	
135	30,188	13.348	10		With 137 excluded $\bar{r} = 13.79$ $\bar{r} = 17.88$
136	30,183	13.304	10		
137	30,184	15.171	8	P R	
HP-124	40,175	17.884	9	A	
125	40,187	17.699	9	A	
126	40,185	18.072	9	A	

Table 3-4
 Tabulation of Burning Rate Data for M-26

TEST	PSIG	CM/SEC	QUALITY OF PEAK FOR TANGENT	INDICATION OF ABNORMAL BURNING	STATISTICAL PARAMETERS
HP-144	25,350	16.67	10		With 147 & 148 excluded $\bar{r} = 16.92$ $S_r = 0.22, \text{cov} = 1.3\%$
145	25,325	17.09	10		
146	25,360	17.00	10		
147	25,328	19.14	7	A P R	
148	25,338	19.26	9	A R	
HP-149	40,370	25.92	10		$\bar{r} = 25.85$ $S_r = 0.55, \text{cov} = 0.2\%$ $S_{\bar{r}} = 0.27, \text{cov} = 0.1\%$
150	40,300	25.86	10		
151	40,305	25.80	10		
152	40,303	25.81	10		
HP-138	10,380	6.90	10		$\bar{r} = 7.24$ $S_r = 0.30$
139	10,339	7.39	10		
140	10,350	7.43	9		

Table 3-5

BURNING RATE PRESSURE SENSITIVITY

	PRINCETON	FELTMAN LAB.	
	SINGLE GRAIN	STRAND	CLOSE CHAMBER
M1 LOT U	0.943*	0.90	0.67
M26	0.938**	0.90	0.80
M30		0.96	0.65

* COEFFICIENT OF DETERMINATION = 0.9993

**COEFFICIENT OF DETERMINATION = 0.9999

BURNING RATE CONSISTENCY OF AS-MANUFACTURED GRAINS

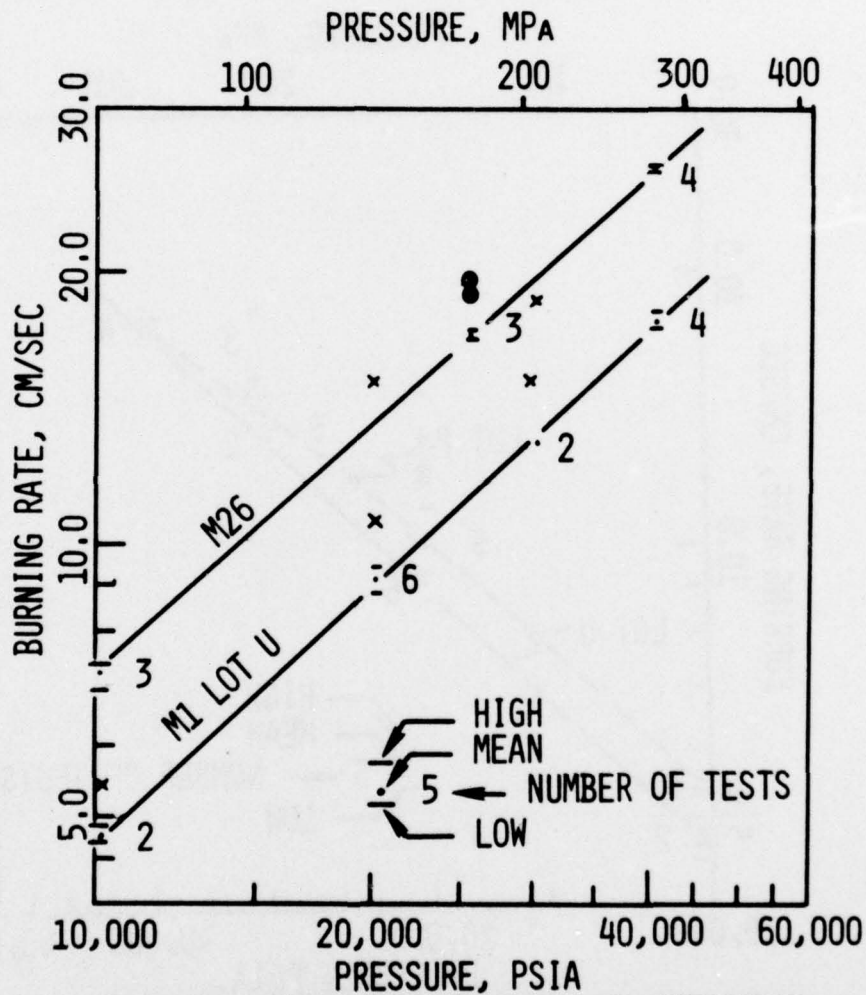

BURNING RATES CORRESPONDING TO SPECIMENS
WHICH EXHIBITED A. E. BLASTS:

- x M1 LOT U (SINGLE BASE)
- M26 (DOUBLE BASE)

Fig. 3-1 Comparison of single base and double base burning rate data. (Tests which exhibited A.E. blasts are not included in mean.)

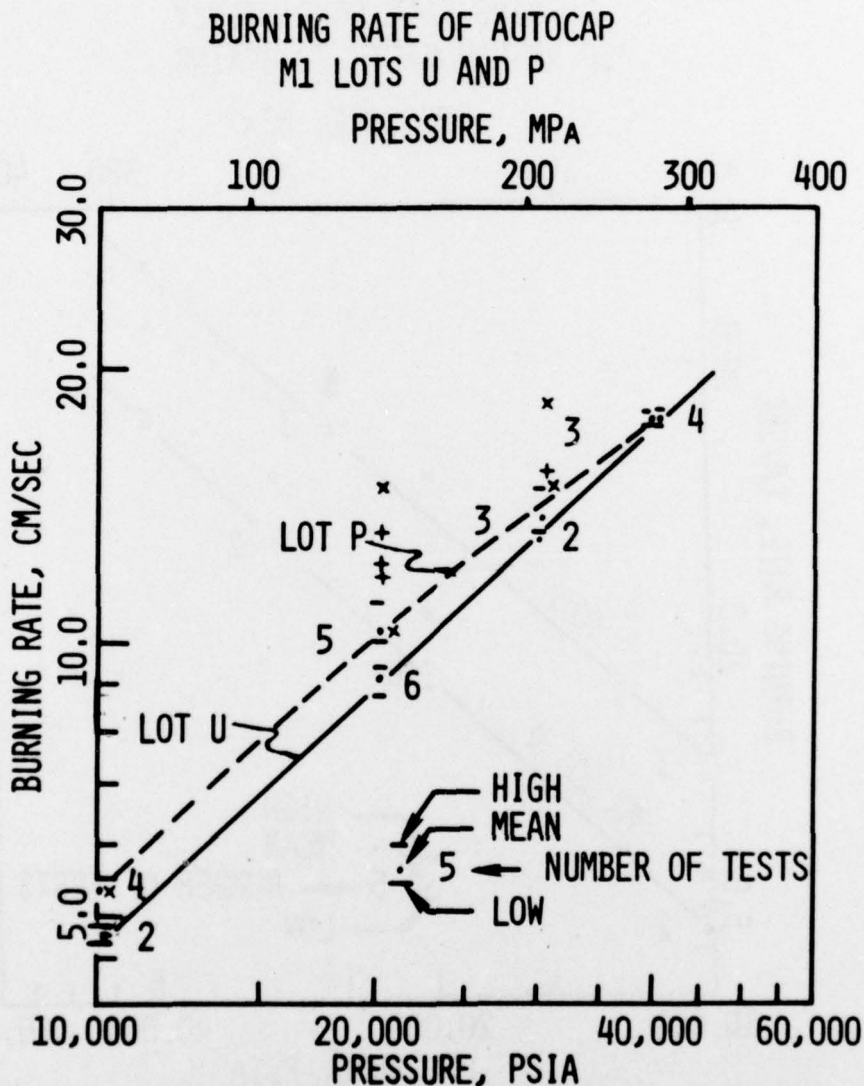

Fig. 3-2 Comparison of two lots of single base propellant showing that the extremes of the burning rate variabilities are similar. (Tests which exhibited A.E. blasts are not included in mean.)

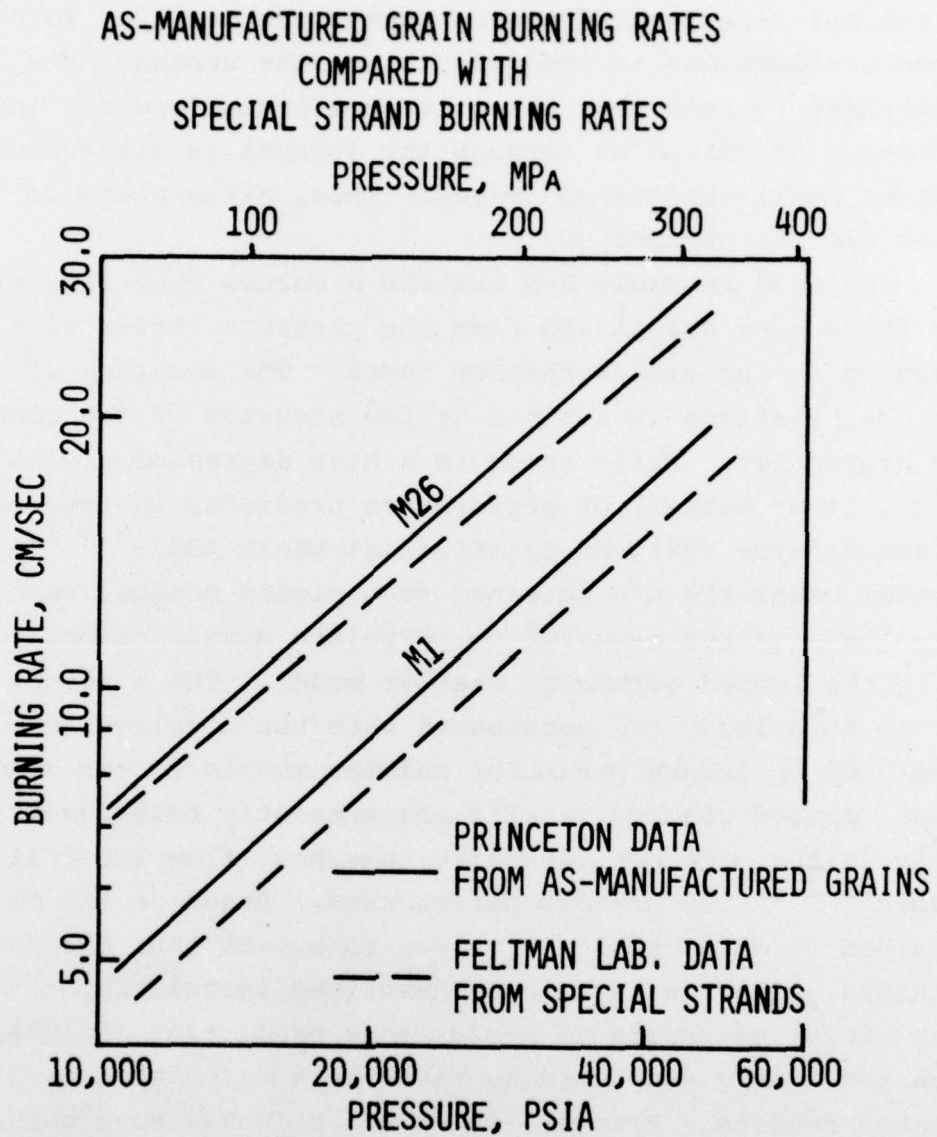

Fig. 3-3 Comparison of burning rates measured at Princeton from as-manufactured grains and at Feltman Laboratories from specially manufactured strands.

this study. It should be noted that the long strands (for laboratory studies) are manufactured using the same procedures as the multi-perforated grains except the die that forms the seven perforations is removed. Since the strands have thicker propellant regions than the multi-perforated grains, the distribution of volatiles through the strands is different than that of multi-perforated grains. Thus, differences in burning rates are not unexpected.

Included in Table 3-5 are the n values from linear burning rates back calculated from the pressure versus time history measured during closed-chamber tests. The accuracy of such back calculations is limited by the accuracy of the combustion gas properties. While there is a high degree of precision (e.g., 1% or better) of performance predicted in terms of relative force (RF) and relative quickness (RQ),^{8,9,10} in several cases the n 's obtained from closed-chamber were lower than the n values required to correlate muzzle velocity data, using the lumped parameter chamber model. The n values measured during this study are consistent with the n values that have been used in lumped parameter chamber models to correlate gun data. Closed chamber results are presently being used successfully in the more comprehensive two-phase flow internal ballistic models^{11,12,13} to predict performance. Based on the data obtained to date, there is reason to expect that the burning rates obtained using the techniques described in this report may be more useful as inputs to performance prediction computer codes than the widely used burning rates back calculated from closed-chamber results. However, it should be noted that burning rates obtained for burning in the axial direction of a multi-perforated grain may differ from the burning rates through the web.

3.2 Burning Rate Uniformity

The RMS of the acoustic emission signal, the alternating components (AC) of the acoustic emission signal, and the pressure rise records for representative tests are shown in Figs. 3-4, 3-5, and 3-6. The results for an irregularly burning propellant specimen (Fig. 3-4) should be compared with

those of a uniformly burning propellant specimen (Fig. 3-5). The history of propellant burning can be traced in Fig. 3-4. When the propellant ignites, a rapid onset of the acoustic emission signal occurs and the pressure in the chamber begins a uniform rise. When the propellant combustion and burning rate are uniform, the acoustic emission level (particularly the RMS signal) is reasonably constant (e.g., the upper trace on Fig. 3-5) compared to the six prominent RMS signal spikes which appear on Fig. 3-4. Such spikes corresponding to enhanced UHFAE output are referred to as A.E. blasts. The peak pressure occurs at strand burn-out. Note that a propellant grain with a regular burning rate has a well-defined pressure peak which corresponds to a relatively flat burning surface intersecting the base of the cylinder; whereas, the irregularly burning propellant grain has an ill-defined pressure peak (or a rather broad pressure plateau) corresponding to the irregular burning surface intersecting the base of the cylinder.

M1 and M26 grains that had burned about 4 or 5 mm were extinguished by rapid depressurization and the contours of the extinguished surfaces examined (see Fig. 3-7). The uniformly burning M26 propellant has surface irregularities which were generally 0.3 mm or less. The surface irregularities of the more uniformly burning M1 propellants were generally on the order of 1 mm and in cases of very irregularly burning specimens, pits as deep as 5 mm occurred. This is direct evidence that the A.E. blasts are associated with localized increases in burning rate.

The propellant specimens which produce the A.E. blasts and ill-defined pressure peaks also have appreciably shorter burning times. The A.E. blasts are believed to be produced during the combustion of local regions (with typical dimensions on the order of 1 mm) of significantly higher burning rate. Indicated on Figs. 3-1 and 3-2 are the burning rate points which were determined from grains which produced A.E. blasts. Note that in all cases those burning rates are high. A direct

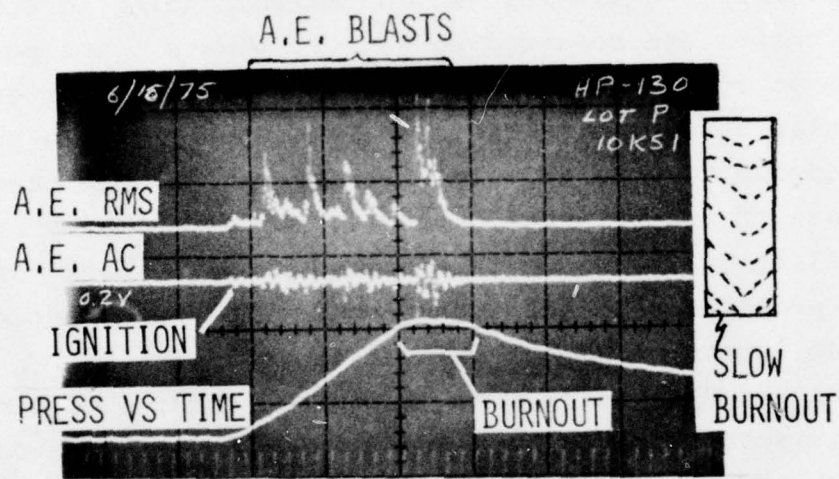

ML LOT P AT 10,000 PSI

Fig. 3-4 Example of high level of acoustic irregularity and the corresponding uneven burnout as indicated by the lack of sharp pressure peak.

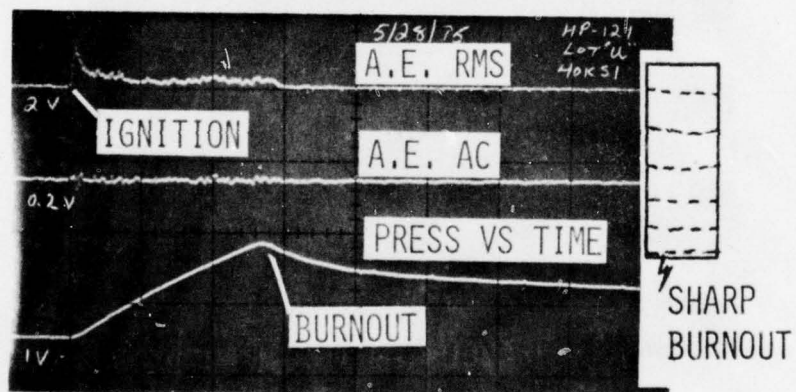

ML LOT U AT 40,000 PSI

Fig. 3-5 Example of very regular acoustic emission and the corresponding sharp burnout.

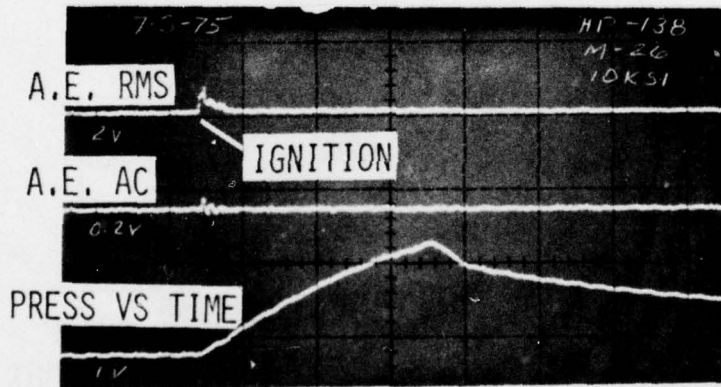

M26 AT 10,000 PSI

Fig. 3-6 Very low acoustic emissions from double-base propellant M26. Pressure 680 atm.

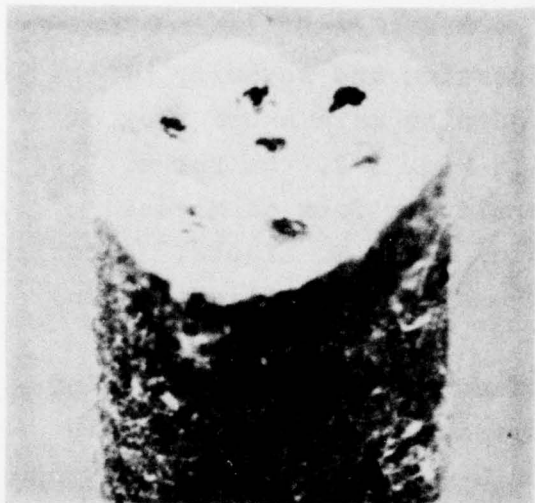

A) TYPICAL SURFACE NONUNIFORMITY
M1 LOT U
DISTANCE BURNED: 0.5 CM
UNEVENNESS: > 0.05 CM DP 29

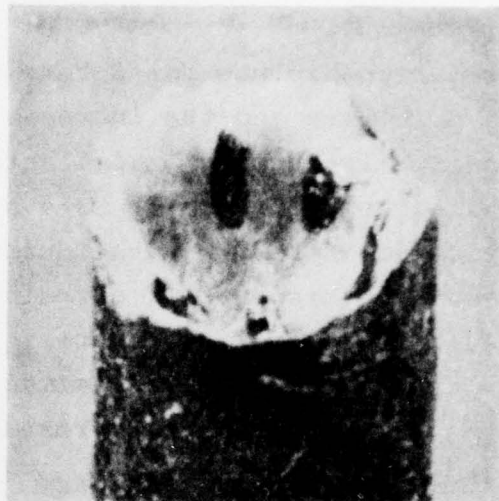

B) EXAMPLE OF SEVERE PITTING
M1 LOT U
DISTANCE BURNED: 0.7 CM
UNEVENNESS: 0.3 CM DP 28

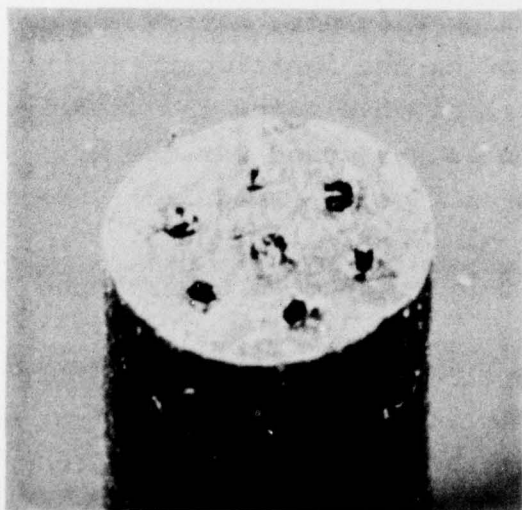

C) UNIFORM SURFACE M26
DISTANCE BURNED: 0.6 CM
UNEVENNESS: < 0.001 CM DP 33
TEST PRESSURE 680 ATM
ALL GRAINS EXTINGUISHED AFTER BURNING AS
AN END BURNER

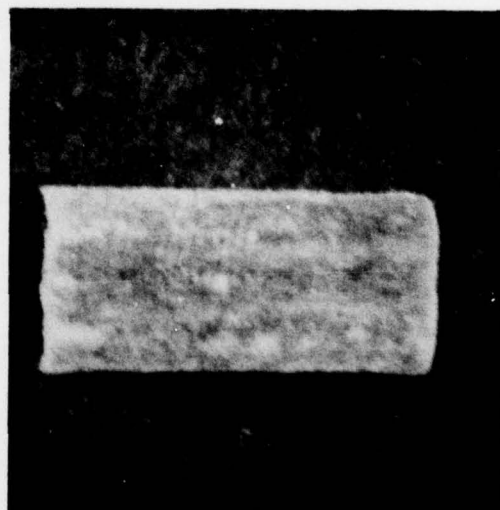

D) CROSS-SECTIONED M1 LOT U
GRAINS SHOWING
NONHOMOGENEOUS REGIONS

Fig. 3-7 Extinguished grains (burned as end burners) reveals that a particular single base propellant (M1) burns very nonuniformly compared to a double base propellant (M26).

relationship was found between duration and severity of the A.E. blasts and the increase in burning rate above that of uniformly burning propellants. In Fig. 3-8, the rather large variations of burning rate of particular lots of M1 are plotted in terms of the duration of the A.E. blasts. A refinement of this type of correlation has direct application in quality control procedures.

A qualitative assessment (based on a 1 to 10 scale) of the sharpness of peak pressure corresponding to burnout is indicated on Tables 3-2, 3-3, and 3-4. The sharpest pressure peak is given a rating of 10. Note the correspondence between the unusually high burning rates and the quality of the pressure peaks.

A close examination of the pressure rise often reveals that associated with the A.E. blasts are small increases in the pressurization rate. This is further evidence that the A.E. blasts are associated with higher burning rates.

The acoustic emission (following the ignition transient) from M26 propellant are barely perceivable using the same instrumentation and amplification as were used for the M1 propellants (compare the results of Figs. 3-5 and 3-6). Normally, the acoustic emission of the M26 was amplified by a factor of ten higher than that in Fig. 3-6 in order to observe the signal.

The reason that the M26 propellant burns more uniformly is probably a result of the nitroglycerin acting as a plasticizer to disperse the fibrous nitrocellulose and the nitroglycerin acting to increase burning rate. Since the nitroglycerin dominates the burning rate-controlling processes, its contributions overcome the discontinuities produced by incomplete dispersion of the fibrous nitrocellulose. In summary, the foregoing discussion shows that three observations are consistent with abnormally short strand burning times: (1) intervals of increased acoustic emission, (2) gradual decrease in pressurization rate at strand burnout, and (3) extinguished burning surfaces which are irregular and pitted.

RELATIONSHIP BETWEEN ACOUSTIC BLAST
AND ABNORMAL BURNING RATES

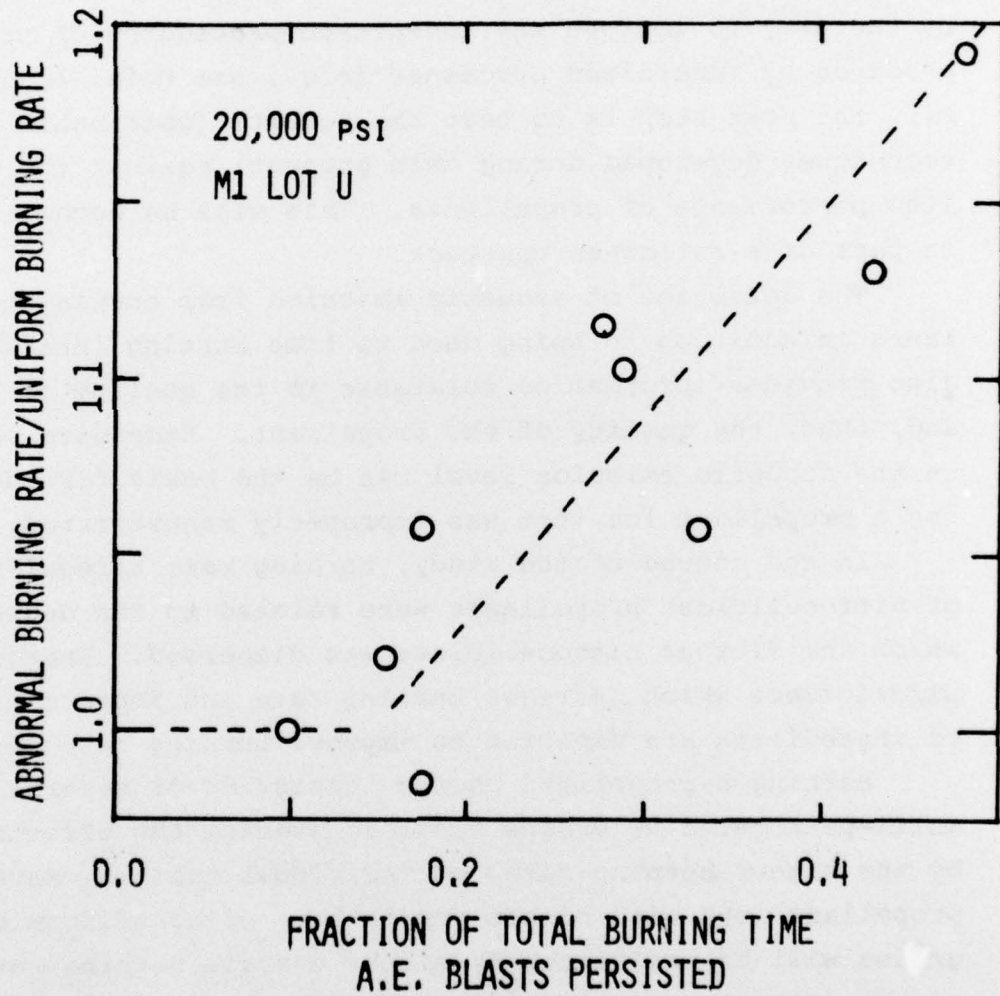

Fig. 3-8 Acoustic emission data indicates that burning rate increases abnormally during period of A.E. blasts.

4.0 CONCLUSIONS

As a result of this project, an accurate, efficient, and economical means of measuring the burning rates (at pressures up to 50,000 psi) of as-manufactured nitrocellulose grains was developed and put into use. In addition, a diagnostic technique for recognizing burning rate nonuniformities was demonstrated. Since this project was part of a broader effort by the Army to improve the acceptance procedures of propellants produced by modernized processes (e.g., see Refs. 1, 8, 9, and 14), the next step is to test the results (obtainable by the techniques developed during this project) against the end-item performance of propellants. This will be accomplished as part of a follow-on contract.

The detection of acoustic emission from burning propellants in addition to being used to time burning intervals also provides information relatable to the quality of burning and, thus, the quality of the propellant. Excessive variation in the acoustic emission level can be the basis for identifying a propellant lot that was improperly manufactured.

In the course of the study, burning rate irregularities of nitrocellulose propellants were related to the degree to which the fibrous nitrocellulose was dispersed. Energetic plasticizers which increase burning rate and improve mixing of ingredients are expected to improve burning rate uniformity.

Burning a propellant charge consisting of several hundred multi-perforated NC grains tends to average the effects produced by the higher burning rates of individual grains. Nevertheless, propellant lots with higher populations of nonuniform burning grains will be manifested by higher overall burning rates (i.e., higher relative quickness¹⁵) and less well-defined pressure versus time programs.

The technique described in this report is relatively easy to implement and is applicable to all classes of propellants. Accordingly, it should be considered whenever propellant burning

rate uniformity is in question (e.g., damage to propellants resulting from high strains, propellants in which dewetting of solid particles is a possibility, and propellants which contain networks of cracks or porous regions).

References

1. Fitzsimmons, F. J., "Concept Scope of Work for PEMA Project 5774186 Acceptance of Propellant Via the Continuous Process (Project AUTOCAP)," Report No. ASRSD-QA-A-P-55-73, Dec. 1972, Product Assurance Directorate, Picatinny Arsenal, Dover, N.J.
2. Saber, A. J., Johnston, M. D., Caveny, L. H., Summerfield, M. and Koury, J. L., "Acoustic Emissions from Burning Propellant Strands," Proceedings of the 11th JANNAF Combustion Conference, Dec. 1974, CPIA Publication No. 261, Vol. I, Laurel, MD, pp. 409-427.
3. Koury, J. L., "Solid Strand Burn Rate Technique for Predicting Fullscale Motor Performance," Air Force Rocket Propulsion Laboratory, Edwards, CA, Report AFRPL-TR-73-49, October, 1973.
4. Strahle, W. C., Craig, J. I., and Palfery, J. G., "Audible and Ultrasonic Acoustic Emissions from Composite Solid Propellants," Proceedings of the 12th JANNAF Combustion Conference, Dec. 1975, CPIA Publication 273, Vol. II, Laurel, MD, pp. 389-402.
5. Caveny, L. H., Felsheim, C. R. and Summerfield, M., "Burning Rate Measurement of Thin Sheets of Double Base Propellant (HEN-12)," AMS Report 1301, Interim Report on Contract DAAA21-74-C-0332, Princeton University, Princeton, N.J., Oct. 1975.
6. Cole, R. B., "Burning Rates of Solid Composite Propellants at Pressures up to 20,000 psig," Report No. S-80, Sept. 15, 1966, Rohm and Haas, Huntsville, Ala.
7. Lenchitz, D. and Shulman, L., Personal Communication, Feltman Research Laboratories, Picatinny Arsenal, November, 1975.
8. Domen, J. K., "Feasibility of Scaled-Down Guns to Duplicate Large Caliber Internal Ballistics," Report No. ASRSD-QA-A-P-64, Product Assurance Directorate, Picatinny Arsenal, July 1974.
9. Serao, P., "A Mathematical Prediction of Ballistic Performance for M6MP Propellant in the 175MM Gun System," Report No. ASRSD-QA-A-P-58-74, Product Assurance Directorate, Picatinny Arsenal, Dover, N.J., April 1974.

10. Baer, P.G., Bushell, M. S., May, I. W. and Frankle, J. M., "The Development of an Interior Ballistic Model for Automated Continuous Propellant Production Control," Proceedings of 12th JANNAF Combustion Meeting, December 1975, CPIA Publication 273, Vol. 1, Laurel, MD, pp. 337-348. Also, "A Comparison of Several Predictive Approaches in Charge Establishment for Large Caliber Artillery System," Proceedings of 11th JANNAF Combustion Meeting, Vol. 1, p. 55-66, Pasadena, CA, September, 1974.
11. Serao, P. personal communication, January, 1976.
12. Fisher, E. B., Graves, K. W., and Trippe, A. P., "Application of a Flame Spread Model to Design Problem in The 155 mm Propelling Charge", Proceeding of the 12th JANNAF Combustion Meeting, CPIA Publ. 273, December, 1975, Vol. 1, pp. 199-219.
13. Gough, P. S., "Fundamental Investigation of the Interior Ballistics of Guns: Final Report" IHCR 74-1, Naval Ordnance Station, Indian Head, MD, July, 1974.
14. Krier, H., Neitzke, T. G., Adams, M. J., Black, J. W. and Meister, E. E., "Solid Propellant Burning Evaluation with the Dynagun Ballistic Simulator," Tech. Report AAE 75-8 UILU - Eng 75 0508, Aero. and Astro. Engineering Department, University of Illinois, Urbana-Champaign, Ill., July 1975.
15. Engineering Design Handbook: Explosive Series, Solid Propellants, U.S. Army Materiel Command, Washington, D.C., AMCP 706-175, Sept. 1964, pp. 20-21.