

AD-A049 998

OREGON STATE UNIV CORVALLIS SCHOOL OF OCEANOGRAPHY  
EXPOSURE. A NEWSLETTER FOR OCEAN TECHNOLOGISTS. VOLUME 5. NUMBE--ETC(U)  
JAN 78 R MESECAR

F/8 8/10

UNCLASSIFIED

NL

| OF |  
AD  
A049998



END  
DATE  
FILMED  
3-78  
DDC

AD A 049998

DDC FILE COPY

JAN NU.

12

# EXPOSURE

vol. 5 no. 6

a newsletter for ocean technologists

EXPOSURE. A Newsletter for Ocean Technologists. Volume 5, Number 6.

## AN EFFICIENT WINCH/CONTROLLER FOR BATTERY-POWERED APPLICATIONS.

DDC  
PAPER  
FEB 15 1978  
RESERVED

An automated profiling system has been developed for obtaining water quality data in the upper 100 m of the water column. Designed for unattended operation from remote battery-powered platforms such as telemetering buoys, the system requires as little as 1.5 Ah of energy for a 15-minute deploy-retrieve cycle. System hardware includes a sensor package, electromechanical cable, winch, winch controller, sensor readout unit, and data processing/control electronics.

In order to minimize energy requirements for battery operation, a computer simulation was derived for defining system component performance characteristics. Variables in the simulation included sensor size and weight, cable diameter and specific gravity, winch drum width and diameter, winch motor speed-torque characteristic and drive train reduction ratio. Using a winch concept developed at Scripps Institution of Oceanography, the simulation was employed to iteratively size the winch components for a minimum energy configuration.

10 Roderick Mesecar

11 January 1978

12 12p

**DISTRIBUTION STATEMENT A**  
Approved for public release  
Distribution Unlimited

272 268 JOB

Referring to Figure 1, the winch assembly consists of a drum and frame, motor, reducer, brake, and slip rings. The drum diameter is 12 inches (with 30-inch flanges) and the drum width is 2.5 inches. With a narrow drum width, a level wind mechanism is not required provided that the cable sheave is located far enough from the drum (in the case 57 inches for a 1.25° fleet angle). The motor is a 24 Vdc, permanent magnet unit. The motor provides 1/3 horsepower at 1800 rpm and has a stall torque of 15 ft-lb. The reduction between motor and drum is 100:1, achieved with a combination of double helical gear reducer (30:1) and cog belt/sprocket drive. The electro-mechanical brake is a failsafe 24 Vdc self-adjusting disc brake. The winch drum and frame are aluminum weldments occupying a volume of 20 ft<sup>3</sup>. The winch weight, including all components, is 250 lb.

Between profiles, the sensor is

stowed in a standpipe in the surface platform (see Figure 2). A sheave is mounted above the well to guide the cable from the deck-mounted winch. During deployment, the sensor depth channel is monitored for a match with stored program sampling depths. When a depth match occurs, the winch is stopped and data are acquired and averaged. After data collection at 100 m, power is removed from the sensor to conserve energy. During retrieval a limit switch mounted on the sheave is monitored for closures actuated by cams molded on the cable. The first closure occurs when the sensor is approximately 3 ft below the buoy bottom; the winch is then slowed for sensor entry into the well. A second closure occurs when the sensor is stowed against a snubber block and power is then removed from the winch motor.

While both constant current (torque) and constant voltage (speed) motor excitation were initially considered,

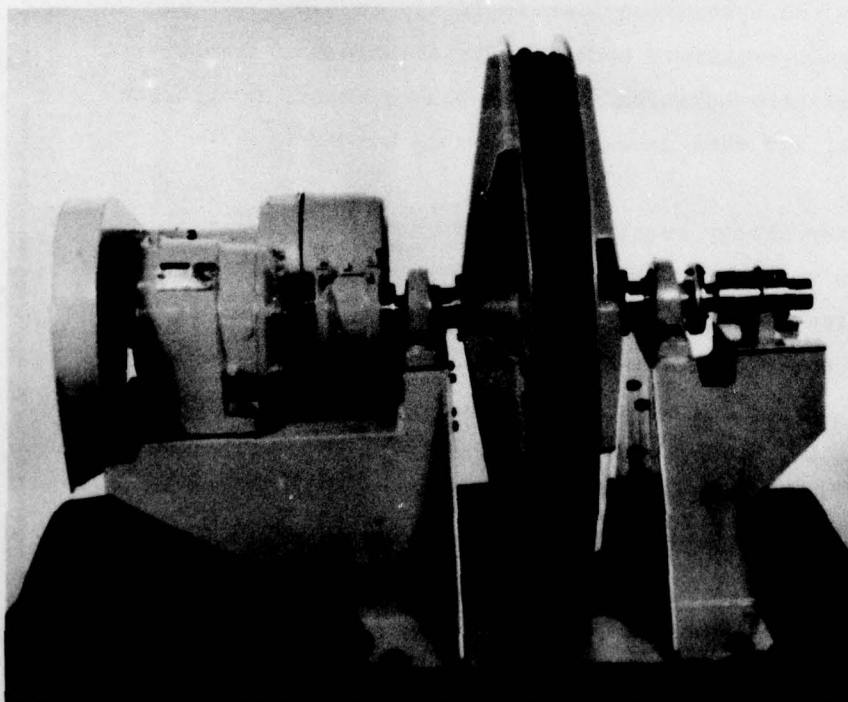

**Figure 1.**

WINCH ASSEMBLY

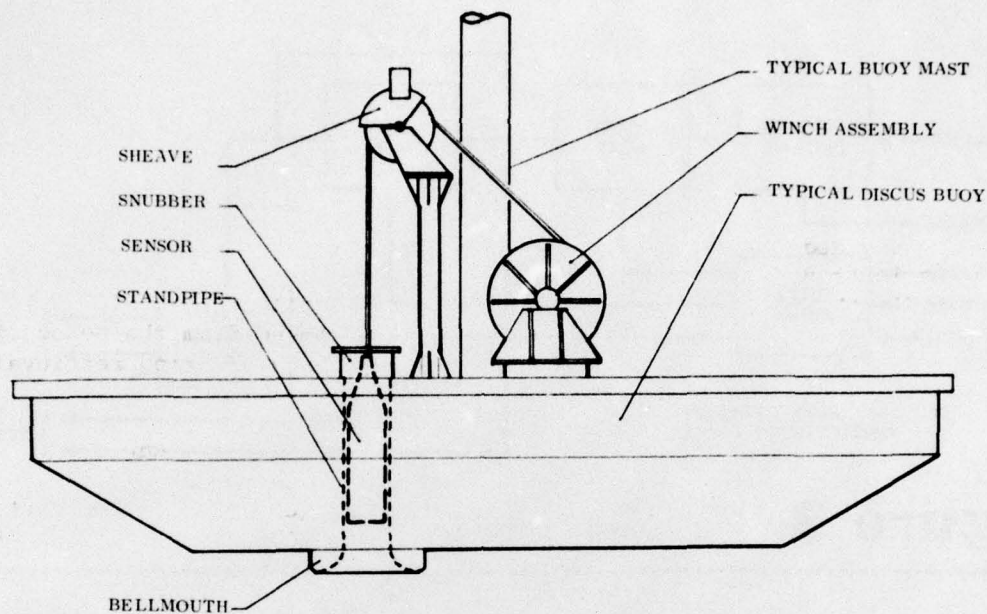

**Figure 2.**

WINCH INSTALLATION ON DATA BUOY

it was determined through computer simulation that constant voltage drive required less energy per profile. A servo-type control was found to be unnecessary in that sufficient speed regulation is afforded by the speed-torque characteristic of the motor. For example, a 2:1 change in torque at the winch drum results in a 10 percent change in drum revolution rate. Referring to Figure 3, the motor controller consists of three relays, relay drivers, a resistor, and an overload detector. The relay drivers are modular optically-coupled solid state switches which are used as current sinks for the relay coils. The optical coupling provides an effective barrier against conducted interference between the 24-V bus and the data/control electronics. The polarity reversal relay has double-pole, double-throw contacts for establishing the proper sense of the excitation voltage during

deployment and retrieval. The speed relay has a set of normally closed contacts which short-circuit the speed resistor. The on/off relay provides a contact closure for connecting the 24-V source, through the speed and polarity relays, to the winch motor and brake. The relays are rated for 100,000 cycles, minimum.

Sensor descent and ascent rates are governed primarily by the speed-torque characteristic of the motor. During deployment, the motor acts as a generator with torque input from the sensor weight and drum level arm. The series diode prevents motor action from occurring at turn-on. At turn-on the motor armature is essentially open-circuited and the sensor accelerates downward until the back emf generated is a diode drop above the battery voltage. At this point the back emf is clamped by the battery

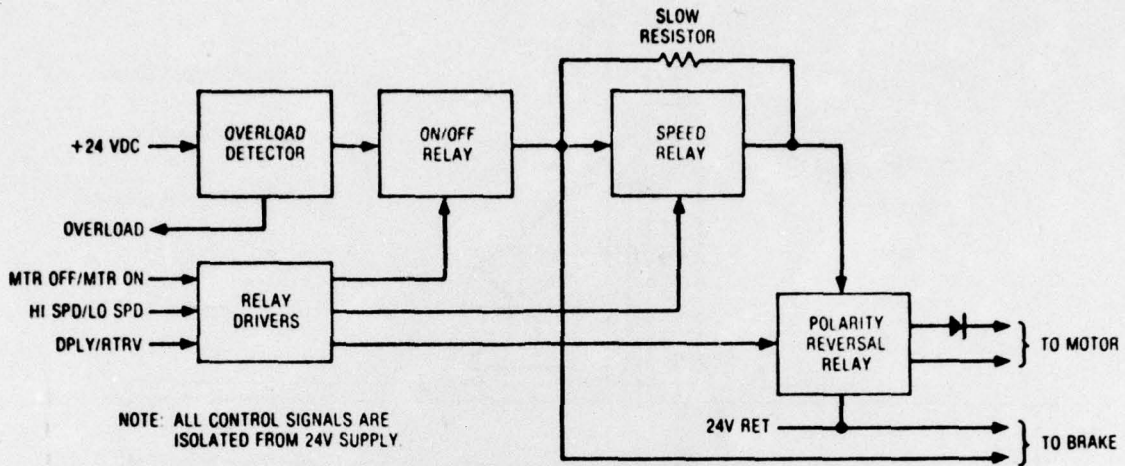

**Figure 3.** MOTOR CONTROLLER

(dynamic braking) and the sensor descent rate is nearly constant at approximately 2.5 ft/s. At the beginning of retrieval the speed resistor is in the circuit to limit the stalled motor current surge at turn-on.

After 3 seconds the resistor is short-circuited and the sensor

ascends at a rate of 2 ft/s. When the sensor is 3 ft below the stow well (limit switch closure) the resistor is switched into the circuit, reducing the ascent rate to less than 1 ft/s for safe entry into the well.

The overload detector is a thermally actuated set of contacts which

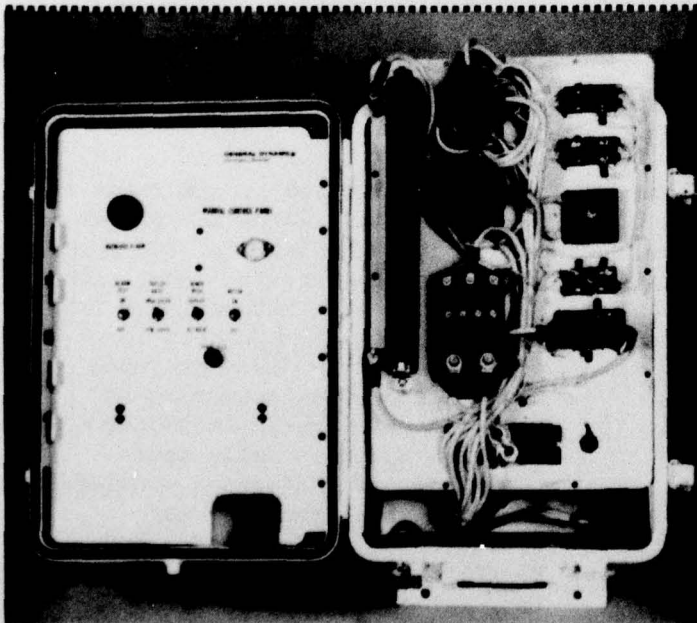

**Figure 4.**

MOTOR CONTROLLER COMPONENTS

ACCESSION for	
NTS	Section <input checked="" type="checkbox"/>
	B. Section <input type="checkbox"/>
	<input type="checkbox"/>
BY	
DISTRIBUTION/AVAILABILITY CODES	
Dist.	SPECIAL
A	

indicate when the motor is stalled. When the overload signal is true, the data/control electronics removes excitation from the motor and initiates a recovery routine. The motor controller with components exposed is shown in Figure 4.

Sea trials were conducted to verify deployment/retrieval rates and retrieval energy requirements under various simulated sea currents. A stow well (standpipe) and sheave were mounted on the transom of a workboat for the tests. Sea currents were simulated by making headway while profiling. Testing with variable ballast indicated that an

inwater sensor weight of 70 lb provided the best overall deployment and retrieval characteristics. The test results are summarized in Table 1. Agreement with analytical predictions was quite good considering uncertainties in drag theory and the difficulties involved in estimating mechanical losses.

Based on sea tests conducted off the California coast, a telemetering buoy as small as 6 m in diameter can support system operation with a battery power supply for one year. A long-term operational deployment from a telemetering buoy is scheduled to begin in January 1978.

**Table 1.** Summary of Deployment and Retrieval Characteristics

Current (knots)	0	2	2.5
Cable Deployed (m)	100	120	130
Deploy Time (s)	180	260	290
Retrieve Time (s)	180	230	260
24V Energy (A-h)	1.15	1.7	1.9



FOR FURTHER INFORMATION, CONTACT:

John Hinchman  
 General Dynamics  
 P.O. Box 81127  
 San Diego, CA 92138

Telephone: (714) 279-7301 (x3469)

*JOHN HINCHMAN is a Principal Engineer with the Ocean System Programs Department of General Dynamics Electronics Division. He received a BSEE from Purdue University in 1964, and an MS in Physical Oceanography from Florida Institute of Technology in 1970. He has been working with ocean instruments since 1968.*

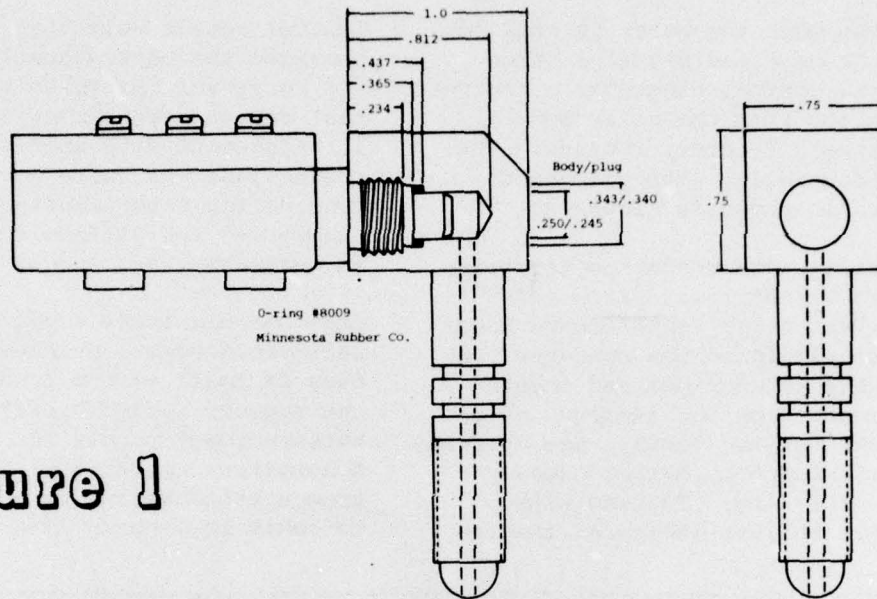

Figure 1

## O-Ring Seal MOD For RCM-5 Pressure Transducer

To obtain some vertical excursion characteristics on 4000-6000 m subsurface current meter moorings for the International Southern Oceans Studies program off New Zealand, the Aanderaa current meters on the moorings needed to be fitted with 5000 psi range pressure transducers. The object of this paper is to illustrate one method of making a reliable pressure seal between the pressure sensor and its mating elbow for end cap mounting on the RCM-4 and RCM-5 current meters.

The previous technique consisted entirely of threading the sensor body into a mating elbow and relying on an epoxy bond to provide the pressure seal around the fitting threads. No attempt was made to utilize the mechanical sealing properties of the sensor's A/N style

fitting. The epoxy technique, while being somewhat questionable, has performed satisfactorily up to pressures of about 2500 psi. Some of the 5000 psi sensors were prepared in this manner and approximately 50 percent failed at pressures as low as 3500 psi.

An O-ring pressure seal immediately appeared to be the practical solution to this problem but it was difficult to simply implement because of the shape of the transducer stem. Normally a washer captured O-ring could be inserted between the transducer base and the elbow face; however, due to the manufacturing technique, the transducer base is sized to a 1/2x1/2 inch square base which provides only a marginal face seal surface. This style of O-ring seal could be used but it requires a concerned hand in assembly.

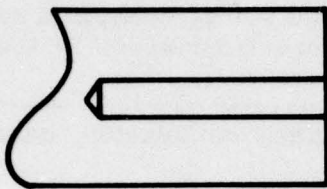

STEP 1

AFTER FACING AND CENTER DRILLING  
STAINLESS STEEL STOCK, DRILL AND  
REAM 0.25 INCHES.

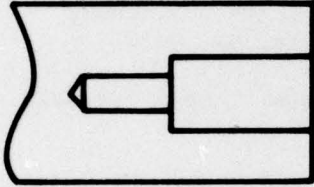

STEP 2

DRILL AND REAM  $11/32$  INCHES.

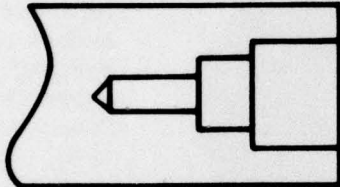

STEP 3

DRILL AND REAM FOR  $7/16$  20 THD.

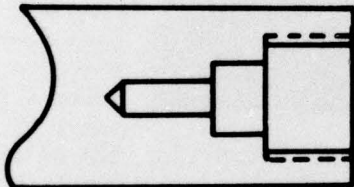

STEP 4

TAP  $7/16$  - 20 THD.

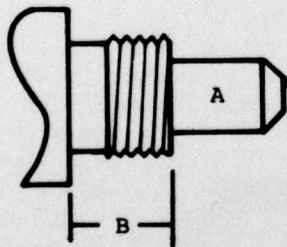

STEP 5

STARTING WITH A  $7/16$  - 20 THD  
PRESSURE TRANSDUCER STEM, TURN  
(A) 0.340, SIZE (B)  $15/64$  INCHES.

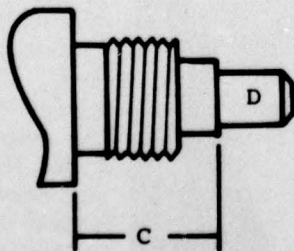

STEP 6

SIZE (C) .390, TURN (D) .245 INCHES.

Figure 2. Machining steps to prepare an O-ring seal for the pressure transducer in the Aanderaa current meter.

The present pressure seal technique uses a plug style O-ring seal which requires a small degree of machining on the sensor A/N fitting and machining a new elbow. Both of these features are shown in Figure 1. The end cap stem of the elbow is made to the same dimensional specifications as the stock unit. The dimensions of the transducer end of the elbow have been adjusted for higher pressures and it is manufactured from 316 alloy stainless steel bar stock.

Machining steps for the plug seal are illustrated in Figure 2. In assembly, the O-ring should be greased and inserted first to avoid any damage in passing by the body threaded section.

The plug and body dimensions have been adjusted so that it is unnecessary for the transducer to be tightened until it is seated. Adequate space has been incorporated in the O-ring chamber to allow the transducer to be loosened by one turn and still maintain pressure integrity. This feature was incorporated so that field installations of previously machined transducers could be done more easily. Field pressure testing for correct transducer mount should not be overlooked. If a small O-ring application does not show an immediate leak at its applied pressure, then it will in all probability last the duration.

The upper working pressure of this design is 5000 psi. Testing of this design was done both in air and submerged in an ice bath and the fittings did not show any signs of leakage at 9800 psi. A long term ocean test for O-ring creep is now in progress for a 3-month period at 3800 psi off the coast of Oregon. Actual deployment of 6 units at or

near 5000 psi is scheduled for the period April-November, 1978, south of New Zealand.

.....  
FOR FURTHER INFORMATION, CONTACT:

John Simpkins  
School of Oceanography  
Oregon State University  
Corvallis, OR 97331

Telephone: (503) 754-3112



*John Simpkins is a research assistant with the School of Oceanography at Oregon State University. Since November of 1976, he has been engaged in the design and deployment of deep, long-term current meter moorings, primarily off the coast of Oregon and in the Antarctic. He received his B.S.M.E. degree from Worcester Polytechnic Institute in 1972.*

*Milton Rowland is a senior scientific instrument technician with the OSU Technical Planning and Develop-*



*ment group. He has 32 years of varied industrial experience in developing specialized prototype equipment. He is a senior member of the American Tool & Die Manufacturing Society and a member of the Carbide Tool Society.*

# Normalizing A Set Of Thermistors For Maximum Sensitivity

A recent application at Oregon State University required a set of 45 matched thermistors capable of interchangeability to within  $\pm 1.0$  percent tolerance. In specialized, high-speed thermistors, this tolerance is not obtainable from the supplier and therefore must be achieved with the available tolerance spread trimmed by a resistor network.

The circuits in Figures 1 and 2 are minimum resistor networks ( $R_{net}$ ) that could be used to trim the sensitivity and center value of the thermistor population of  $R_T$ 's to a population of  $R_{net}$ 's. Both circuits are equivalent when viewed from the two terminal ports, but Figure 1 is chosen because it separates the calculation for  $R_P$  and  $R_S$  into two independent computations.  $R_P$  is used to lower the sensitivity of the network to responses in  $R_T$  and  $R_S$  is used to establish the nominal value of  $R_{net}$  at a given temperature.

As might be expected, the trim procedure lowers the overall sensitivity of the network. The problem is to choose an algorithm which maximizes the residual sensitivity.

The approach generally used is to normalize the set to the mean value of the population. This is done by degrading the network composed of the mean value  $R_T$  with a set of  $R_S$  and  $R_P$  which will degrade the sensitivity by the reciprocal of the population spread. Thus, if the worst case thermistors have values around a mean  $R_T \pm 20$  percent, then the abstract mean network is composed of  $R_T$  mean and:

$$R_S \text{ mean} = (.2) R_T \text{ mean}$$

$$R_P \text{ mean} = R_T \text{ mean} / (.2)$$

Given  $R_T$  mean at two temperatures and  $R_T$  at two temperatures for the thermistor to be normalized, then  $R_S$  and  $R_P$  for each such thermistor can be obtained by simultaneous solution.

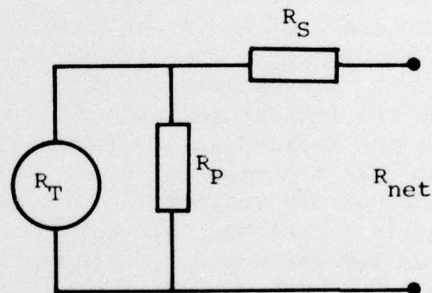

Figure 1.

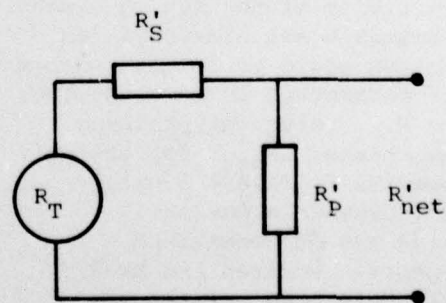

Figure 2.

In investigating this solution, we felt that the resulting sensitivity was too low. The set of thermistors which we received had a distribution which was distinctly nongaussian. The normalization to the mean is optimum only for gaussian distributions. In analyzing the network it was discovered that the change in resistance between two calibration temperatures,  $\Delta R_{net}$ , could never be larger than the change in the resistance of the least sensitive thermistor,  $\Delta R_T$ . Thus by plotting a distribution of  $\Delta R_T$  of the population, the least sensitive members of the set can be identified and anomalously insensitive members deleted. This leaves a thermistor which has the smallest change,  $\Delta R_{T \min}$ , to which the population can be normalized. For each thermistor, it is necessary to compute the value of resistor  $R_P$  to reduce the  $\Delta$  of  $R_T$  in parallel with  $R_P$  to  $\Delta R_{T \min}$ . Then individual values of  $R_S$  can be calculated to increase the network resistance value to the desired  $R_{net}$ . This requires that the value of resistance of the minimum sensitivity thermistor,  $R_{T \min}$ , be less than the desired  $R_{net}$ . It may be found that high-valued, low-sensitivity thermistors may cause the network to exceed the desired  $R_{net}$  with no  $R_S$ . This can be solved by omitting these members or by accepting additional degradation in sensitivity of the set in order to accommodate all elements. An alternative would be to alter other circuit parameters to increase the desired  $R_{net}$  value, maintaining maximum change,  $\Delta R_{net}$ , for the set. The formulas in Figure 3 will, however, provide a maximally sensitive set of normalized thermistors. Fortran and SR-52 routines have been written to perform this calculation and are available from the author.

The computational procedure described in Figure 3 assumes that the thermistors exhibit idealized behavior with temperature. This is,

Two calibration temperatures  $T_A < T_B$

$R_{TA}$  = Thermistor resistance at  $T_A$

$R_{netA}$  = Thermistor resistance at  $T_A$

$R_{minA}$  = Least sensitive thermistor resistance at  $T_A$

$$\Delta = R_{minA} - R_{minB}$$

To set  $\Delta R_{net} = \Delta$ , satisfy

$$\frac{1}{\frac{1}{R_P} + \frac{1}{R_{TA}}} - \frac{1}{\frac{1}{R_P} + \frac{1}{R_{TB}}} = \Delta$$

giving

$$\left(\frac{1}{R_P}\right)^2 \Delta + \left(\frac{1}{R_P}\right) \left(\frac{\Delta}{R_{TA}} + \frac{\Delta}{R_{TB}}\right) + \dots$$

$$\dots \left(\frac{\Delta}{R_{TA} R_{TB}} + \frac{1}{R_{TA}} - \frac{1}{R_{TB}}\right) = 0$$

Let

$$a = \Delta$$

$$b = \Delta \left(\frac{1}{R_{TA}} + \frac{1}{R_{TB}}\right)$$

$$c = \frac{1}{R_{TA} R_{TB}} + \frac{1}{R_{TA}} - \frac{1}{R_{TB}}$$

then

$$R_P = 2a / (-b + \sqrt{b^2 - 4ac})$$

$$R_S = \text{Desired } R_{netA} - \frac{R_P R_{TA}}{R_P + R_{TA}}$$

Figure 3.

of course, not the case. As a result, care should be taken to choose the normalization temperatures to maximize the fit in the region of interest. Our thermistor temperature sensor application had a full scale range of 0°C to 24°C. By choosing the end points of this range, considerable error will result in the normalization through the midrange where the most probable data will be encountered. A better choice was to use 8°C and 16°C, holding the center range error down. The resistor values, constrained by the value limitations above, represent less than 20 percent of the network resistance. By choosing the nearest 1 percent resistor value, a maximum error in the resistor contributes a .2 percent error to the network. Accepting that error as a budget limit leads one to discover that only the maximum values of  $R_S$ ,  $R_{S \max}$ , and minimum values of  $R_P$ ,  $R_{P \min}$ , need be the next closest 1 percent value. As the percent of  $R_{net}$  that the resistors represent decreases, then a grouping of values of  $R_S$  or  $R_P$  can be made which can utilize a single value of resistance. At  $R_S = 1/2 R_{S \max}$ , 1 percent represents only .1 percent of  $R_{net}$  and either of two 1 percent values will suffice. The binary series (1/4  $R_S$  can be represented by one of four 1 percent values, etc.) continues until  $R_S$  itself represents less than .2 percent of  $R_{net}$ , at which point  $R_S = 0$  can be used for all values which are smaller. For  $R_P$ , the series is the same except the classes become  $R_{P \min}$ ,  $2R_{P \min}$ ,  $4R_{P \min}$ , etc., until  $R_P$  can be omitted. An odd series such as 3, 6, 12, etc., might be more appropriate since each of the smaller classes would include a center value. The point is that not every member of the 1 percent series is needed to meet the requirements of normalizing the set.

The appropriate ranges of values for  $R_P$  and  $R_S$  are:

$$\frac{R_{net}}{.002} > R_P > R_T/0.2$$

$$.002 R_{net} < R_S < R_T (0.2)$$

Any normalization using values outside the limits on the right will result in the normalizing resistors contributing considerable drift and inaccuracies to the network. The temperature response of the network is measured in the calibration setup at steady state temperature. The thermal time constants of the resistors and the thermistor will be different causing the dynamic accuracy of the system to be degraded--but not the dynamic resolution. It thus becomes reasonably important to place the normalizing resistors as close to the thermistor as is practical. Leakage in the interconnects also dictates close placement.

Our experience has shown a 20 percent increase in sensitivity over the  $R_{mean}$  solution by truncating 12 members from the full set of 60 thermistors giving 48 networks matched to within  $\pm 1$  percent. This was accomplished by using easily available 1 percent, 25 ppm, axial lead resistors. These resistors contribute very little to the accuracy and temperature coefficient since  $R_P > 6 R_T$  for all samples.  $R_S$  could have been  $< 5$  percent of  $R_{net}$  and satisfied the normalization, but the population that we were working with was below our target  $R_{net}$  by 25 percent and needed to be augmented.

FOR FURTHER INFORMATION, CONTACT:

Frank Evans  
School of Oceanography  
Oregon State University  
Corvallis, OR 97331

Telephone: (503) 754-2206



Frank Evans received his education in electronics from the University of California at Berkeley. He has worked on high security multiplexed alarm systems, biomedical instrumentation, and physiological

optics. He is a member of the Technical Planning & Development Group at OSU and is currently working on multiplexed data systems for oceanography.



TABLE OF CONTENTS

Page	Article	Author
1	An Efficient Winch/ Controller For Battery-Powered Applications	Hinchman
6	O-Ring Seal MOD For RCM-5 Pressure Transducer	Simpkins/ Rowland
9	Normalizing A Set Of Thermistors For Maximum Sensitivity	Evans

NOTE:

Ben Cagle has prepared a limited edition of notes on the 1977 Ocean Technologists' meeting, held in Victoria. A copy can be obtained from the editor of EXPOSURE.



EXPOSURE  
Rod Mesecar, Editor  
School of Oceanography  
Oregon State University  
Corvallis, Oregon 97331