

AD-A050 150

NAVAL COASTAL SYSTEMS LAB PANAMA CITY FLA

F/8 13/10

TOWED PLANING SLED FOR DELIVERY OF OIL POLLUTION CONTROL EQUIPM--ETC(U)

AUG 77 R S WARD

MIPR-Z-70099-4-42734

UNCLASSIFIED

USCG-D-7-77

NL

| OF |  
AD  
A050160

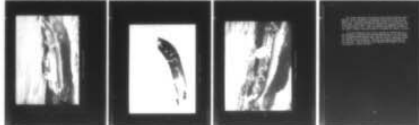

END  
DATE  
FILMED  
3 -78  
DDC

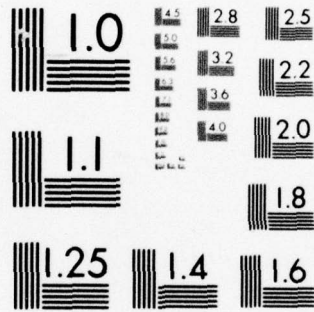

MICROCOPY RESOLUTION TEST CHART  
NATIONAL BUREAU OF STANDARDS-1963-A

12  
U.S.

AD A 050150

Report No. CG-D-70-77

# TOWED PLANING SLED FOR DELIVERY OF OIL POLLUTION CONTROL EQUIPMENT

ADDENDUM 1,

## IMPROVED VERSION OF TOWED PLANING SLED FOR OPERATION IN WET OR DRY MODE,



**RUSSELL S. WARD**

Prepared by  
**NAVAL COASTAL SYSTEMS LABORATORY**  
Panama City, Florida



**AUGUST 1977**

Document is available to the U.S. public through the  
National Technical Information Service,  
Springfield, Virginia 22161

for  
**DEPARTMENT OF TRANSPORTATION**  
**UNITED STATES COAST GUARD**

Office of Research and Development  
Washington, D.C. 20590

DDC  
RECEIVED  
FEB 21 1978  
B

AD No. 1  
DDC FILE COPY

407 276 J.B

## NOTICE

This document is disseminated under the sponsorship of the Department of Transportation in the interest of information exchange. The United States Government assumes no liability for its contents or use thereof.

The United States Government does not endorse products or manufacturers. Trade or manufacturers' names appear herein solely because they are considered essential to the object of this report.

The contents of this report do not necessarily reflect the official view or policy of the U. S. Coast Guard and do not constitute a standard, specification, or regulation.

Technical Report Documentation Page

1. Report No. USCG-D-70-77	2. Government Accession No.	3. Recipient's Catalog No.
4. Title and Subtitle TOWED PLANING SLED FOR DELIVERY OF OIL POLLUTION CONTROL EQUIPMENT, Addendum 1 Version of towed Planing Sled for Operation in Wet or Dry Mode.	5. Report Date August 1977	6. Performing Organization Code 30 P.
7. Author(s) Russell S./Ward	8. Performing Organization Report No.	10. Work Unit No. (TRAVIS)
9. Performing Organization Name and Address Naval Coastal Systems Laboratory Panama City, Florida 32407	11. Contract or Grant No. MIPR-Z-7099-4-42734	12. Type of Report and Period Covered Final rept.
12. Sponsoring Agency Name and Address United States Coast Guard 400 Seventh Street, S.W. Washington, D. C. 20590	14. Sponsoring Agency Code G-DOE	
15. Supplementary Notes USCG 19 D-70-77	DDC RECEIVED FEB 21 1978	
16. Abstract Design of the FSD sled previously developed at NCSL to be used for fast surface delivery of pollution control equipment was modified to provide a means to use the sled as a non-submerged or dry boat for transportation of non-floatable loads or a dry work platform in addition to the original use for delivery of pollution control equipment.  The FSD sled was designed to have the capability of manually loading and off-loading floating equipment at sea. At rest in water the empty sled lies with the aft end submerged. After the floating payload is aboard and the sled is under way, the water drains, the stern comes up, and the sled hydroplanes. At the deployment site, lines securing the equipment to the sled are released and the stern submerges, leaving the payload floating free.  The improved version (wet-dry sled) is similar to the FSD sled, but has been modified by adding a hatch at the stern that can be closed to seal the hull to provide a dry boat. Other modifications were made to improve handling and performance capabilities of the sled.		
17. Key Words Planing Surface: Oil Pollution Control Equipment Towed Vehicle Sleds	18. Distribution Statement Document is available to the U. S. public through the National Technical Information Service, Springfield, Virginia 22161	
19. Security Classif. (of this report) Unclassified	20. Security Classif. (of this page) Unclassified	21. No. of Pages 27
22. Price		

407 276 JOB

**ADMINISTRATIVE INFORMATION**

This task was authorized by Amendment 5 to Military Interdepartmental Purchase Request No. Z-70099-4-42734-A of April 1976 issued by Commandant (G-FCP-2/71) U.S. Coast Guard, Washington, D. C. 20590 (NCSL Task No. PR-42734-2). The task began May 1976 and this report completes the authorized work.

Appreciation is extended to LCDR R. M. Larrabee, Coast Guard Project Officer; CWO Paul Sparrow and the National Strike Force members; and the officers and crew of the Coast Guard's POINT LOBOS for their guidance, cooperative attitude, and assistance during this task.

ACCESSION for		
NTIS	White Section	<input checked="" type="checkbox"/>
DDC	Buff Section	<input type="checkbox"/>
UNANNOUNCED		<input type="checkbox"/>
JUSTIFICATION _____		
BY _____		
DISTRIBUTION/AVAILABILITY CODES		
Dist.	AVAIL.	and/or SPECIAL
A		

### METRIC CONVERSION FACTORS

When You Know	Multiply by	To Find	Symbol
<b>LENGTH</b>			
millimeters	0.04	inches	in
centimeters	0.4	inches	in
meters	3.3	feet	ft
kilometers	1.1	yards	yd
	0.6	miles	mi
<b>AREA</b>			
square centimeters	0.16	square inches	in <sup>2</sup>
square meters	1.2	square yards	yd <sup>2</sup>
square kilometers	0.4	square miles	mi <sup>2</sup>
hectares (10,000 m <sup>2</sup> )	2.5	acres	ac
<b>MASS (weight)</b>			
grams	0.005	ounces	oz
kilograms	2.2	pounds	lb
tonnes (1000 kg)	1.1	short tons	st
<b>VOLUME</b>			
milliliters	0.03	fluid ounces	fl oz
liters	2.1	pints	pt
liters	1.06	quarts	qt
liters	0.26	gallons	gal
cubic meters	36	cubic feet	ft <sup>3</sup>
cubic meters	1.3	cubic yards	yd <sup>3</sup>
<b>TEMPERATURE (exact)</b>			
°C	9/5 (then add 32)	Fahrenheit temperature	°F

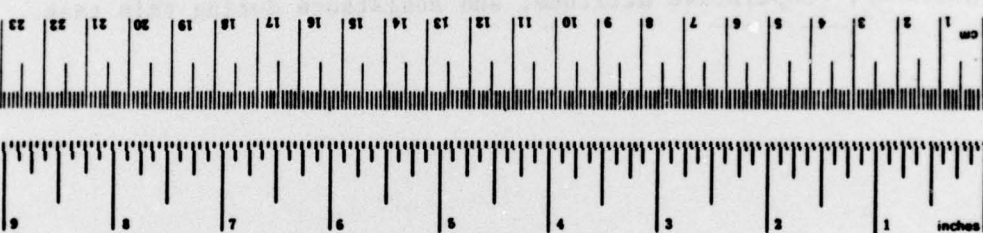

When You Know	Multiply by	To Find	Symbol
<b>LENGTH</b>			
inches	*2.5	centimeters	cm
feet	30	centimeters	cm
yards	0.9	meters	m
miles	1.6	kilometers	km
<b>AREA</b>			
square inches	6.5	square centimeters	cm <sup>2</sup>
square feet	0.09	square meters	m <sup>2</sup>
square yards	0.8	square meters	m <sup>2</sup>
square miles	2.6	square kilometers	km <sup>2</sup>
acres	0.4	hectares	ha
<b>MASS (weight)</b>			
ounces	28	grams	g
pounds	0.46	kilograms	kg
short tons (2000 lb)	0.5	tonnes	t
<b>VOLUME</b>			
teaspoons	5	milliliters	ml
tablespoons	15	milliliters	ml
fluid ounces	30	milliliters	ml
cup	0.24	liters	l
pint	0.47	liters	l
quart	0.96	liters	l
gallon	3.8	liters	l
cubic feet	0.03	cubic meters	m <sup>3</sup>
cubic yards	0.76	cubic meters	m <sup>3</sup>
<b>TEMPERATURE (exact)</b>			
Fahrenheit temperature	5/9 (after subtracting 32)	Celsius temperature	°C

\*1 in = 2.54 (exact). For other exact conversions and more detailed tables, see NBS Misc. Publ. 286, Units of Length and Measures, Price \$2.25, SD Catalog No. C-13,10286.

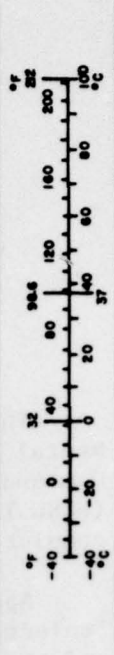

TABLE OF CONTENTS

	<u>Page No.</u>
INTRODUCTION. . . . .	1
Background . . . . .	1
Objectives . . . . .	1
DESCRIPTION . . . . .	1
DEVELOPMENT . . . . .	2
First Objective. . . . .	2
Second Objective . . . . .	4
Drawings and Specifications. . . . .	7
Fabrication. . . . .	9
TESTS . . . . .	9
Dockside . . . . .	9
Single Tow Tests . . . . .	10
Dual Tow Tests . . . . .	10
Repair . . . . .	12
STABILITY STUDIES . . . . .	14
General. . . . .	14
Overturn Configurations. . . . .	14
Computations . . . . .	14
BOAT RESCUE AND BUOY RECOVERY . . . . .	18
CONCLUSIONS . . . . .	18

## LIST OF ILLUSTRATIONS

<u>Figure No.</u>		<u>Page No.</u>
1	Attitudes for Loading	3
2	Attitude Adjustment Method	5
3	Stern Ballasting System	6
4	Hatch Operation	7
5	Wet-Dry Sled Stern Components	8
6	Tandem Tow	11
7	Side-by-Side Tow	13
8	Maximum Safe Roll Angle	15
9	Loading Boat in Sled	19
10	Sled Carrying Boat	20
11	Loading Buoy in Sled	21
12	Sled Carrying Buoy	22

## INTRODUCTION

### BACKGROUND

In accordance with the first Coast Guard Military Purchase Request (MIPR) No. Z-70099-4-42734 for this task a developmental model of a Fast Surface Delivery (FSD) System for pollution control equipment was designed, manufactured, tested and evaluated at the Naval Coastal Systems Laboratory (NCSL). Report No. CG-D-59-76 documented the results of that task. In May 1976 the Coast Guard authorized a second phase of the Planing Hull Sled concept by Amendment 5 to the MIPR. The results of the work done under the amendment are summarized in this addendum.

### OBJECTIVES

The objectives of the amendment were:

1. Construct the second FSD sled which was planned under the original MIPR but was canceled in Amendment 2. This Amendment also provided for examining the original design and making any changes or modifications necessary for improvement. Prior to construction of the second sled the present design will be changed to close in the open transom and install a valving system so that the sled may be used in either the originally planned fashion or as a conventional hull.
2. After construction of the second sled a modest test will be undertaken to test the sled and to examine the concept of tandem tow.

### DESCRIPTION

The wet-dry sled is a modified version of the FSD sled previously developed at NCSL to be used for delivery of pollution control equipment where needed. The wet-dry sled was developed to provide a means to use the sled as a non-submerged or dry boat for transportation of non-floatable loads or a dry work platform in addition to the original use for delivery of pollution control equipment.

The FSD sled was designed to have the capability of loading and off-loading floating equipment at sea manually. The empty sled at rest in water lies with the aft end submerged. Sled-mounted hand winches are used to haul in and secure the floating payload. After the sled is underway the water drains, the stern comes up, and the sled hydroplanes. At the deployment site, quick-release hooks on the lines securing the equipment to the sled are tripped and the stern submerges, leaving the payload floating free.

The wet-dry sled has the capability of the FSD sled, but has been modified by adding a hatch at the stern that can be closed to seal the hull to provide a dry boat.

For delivery of pollution control equipment, the hatch will be secured in the open position to allow water to free flood and drain. To convert the wet sled to a dry boat, the water must be drained from the hull, and the hatch closed and secured. To accomplish the wet-to-dry conversion at sea, a man on board the sled will close and secure the stern hatch after the sled is underway and the water has drained from the hull.

## DEVELOPMENT

### FIRST OBJECTIVE

In accordance with Amendment 5 and after close examination, the following modifications in the original design were incorporated:

1. A single float was designed to replace the multiple boat fenders used on each side of the sled to control the depth of the submerged stern.
2. Provision was made to adjust the depth of the submerged stern to provide deck clearance for loading the particular pollution control equipment from the water.

The required attitude of the sled is determined by the depth of the bottom of the equipment to be loaded and is controlled by the length of the float line. For example, if the stern is to be raised the float lines must be taken in. The Barrier and the recovery equipment require that the stern of the sled be submerged sufficiently to provide a down-by-the-stern attitude of 18 degrees while the ADAPTS equipment requires that the stern be submerged to a lesser depth with an attitude of 6 degrees (Figure 1). Each float line supports approximately 200 pounds, so it is difficult to take in on the line manually. However, the center

(Text Continued on Page 4)

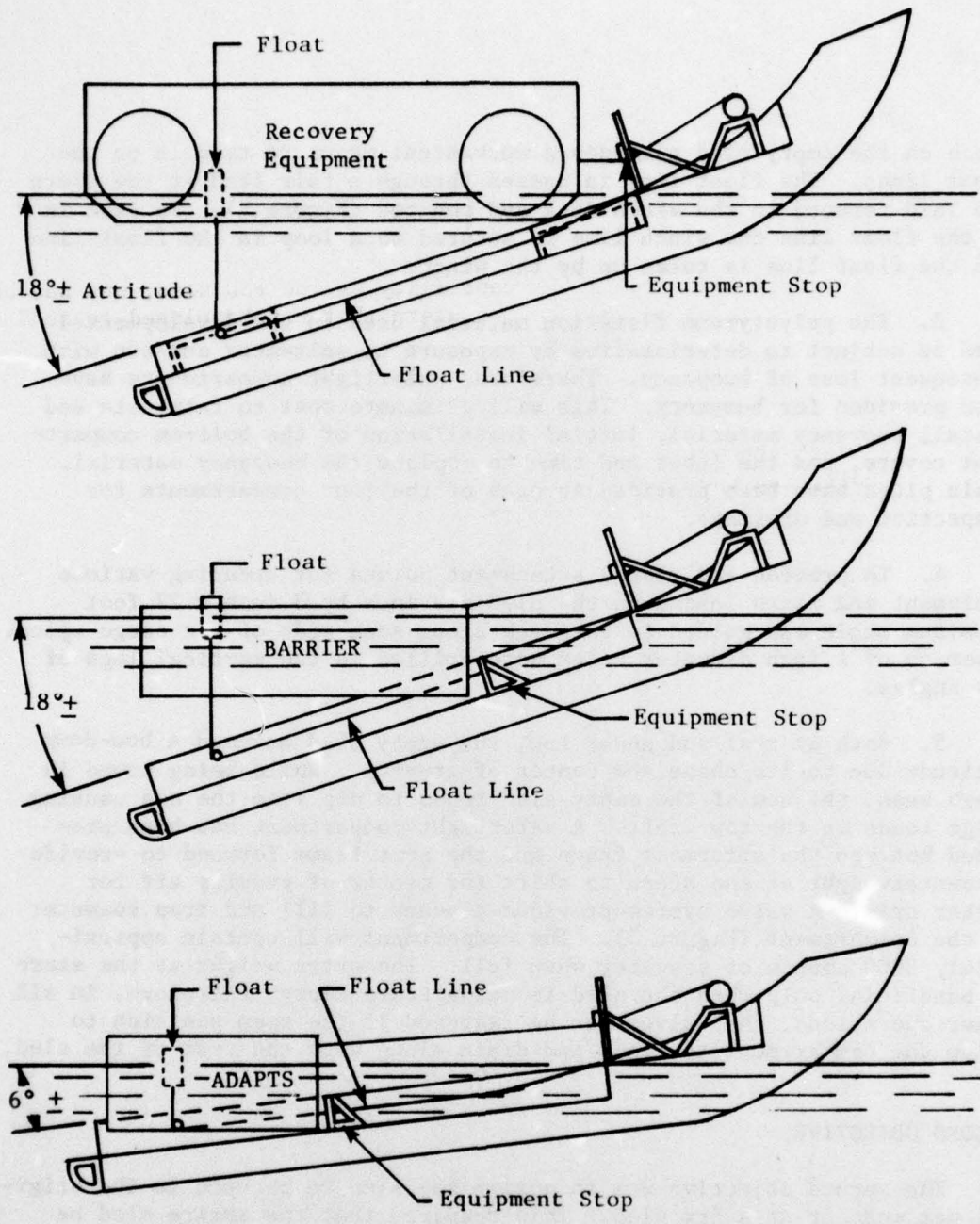

FIGURE 1. ATTITUDES FOR LOADING

winch on the empty sled provides a mechanical means to take in on the float lines. The float line is passed through a fair lead at the stern and laid forward to the winch deck and secured (Figure 2). To take in on the float line the winch line is secured to a loop in the float line and the float line is taken up by the winch.

3. The polystyrene flotation material used in the developmental sled is subject to deterioration by exposure to saltwater and sun with subsequent loss of buoyancy. Therefore, watertight compartments have been provided for buoyancy. This will eliminate cost to fabricate and install buoyancy material, initial installation of the bolt-on compartment covers, and the labor and time to replace the buoyancy material. Drain plugs have been provided in each of the four compartments for inspection and drainage.

4. To provide additional attachment points for securing various equipment and parts loaded on the sled a 3 inch by 3 inch x 27 foot aluminum angle was welded to the deck along each side of the cargo space. A series of 1 inch diameter holes were drilled in the vertical legs of the angles.

5. Both at rest and under tow, the empty sled assumed a bow-down attitude due to its shape and center of gravity. While being towed in rough seas, the bow of the empty sled tends to dip into the sea causing surge loads on the tow craft. A watertight compartment has been provided between the aftermost frame and the next frame forward to provide a counterweight at the stern to shift the center of gravity aft for better trim. A valve system provides a means to fill and trap seawater in the compartment (Figure 3). The compartment will contain approximately 3000 pounds of seawater when full. The extra weight at the stern is beneficial only when the sled is being towed empty; therefore, in all other operations, the valves can be fastened in the open position to allow the compartment to flood and drain along with the rest of the sled.

## SECOND OBJECTIVE

The second objective was to design the sled to be used in the original wet mode or as a dry sled. This required that the entire sled be made watertight with an opening at the stern that could be sealed when desired. The stern opening was made as large as practical for fast drainage and flooding. A hinged hatch cover is used for sealing the opening when the sled is to be used dry (Figures 4 and 5). A cable attached to the inboard side of the hatch cover leads forward underneath the cargo deck to a small winch on the winch deck. The hatch can be sealed by winding in the small winch. A nylon line attached to the outboard side of the hatch cover is led along the top of the cargo deck

(Text Continued on Page 7)

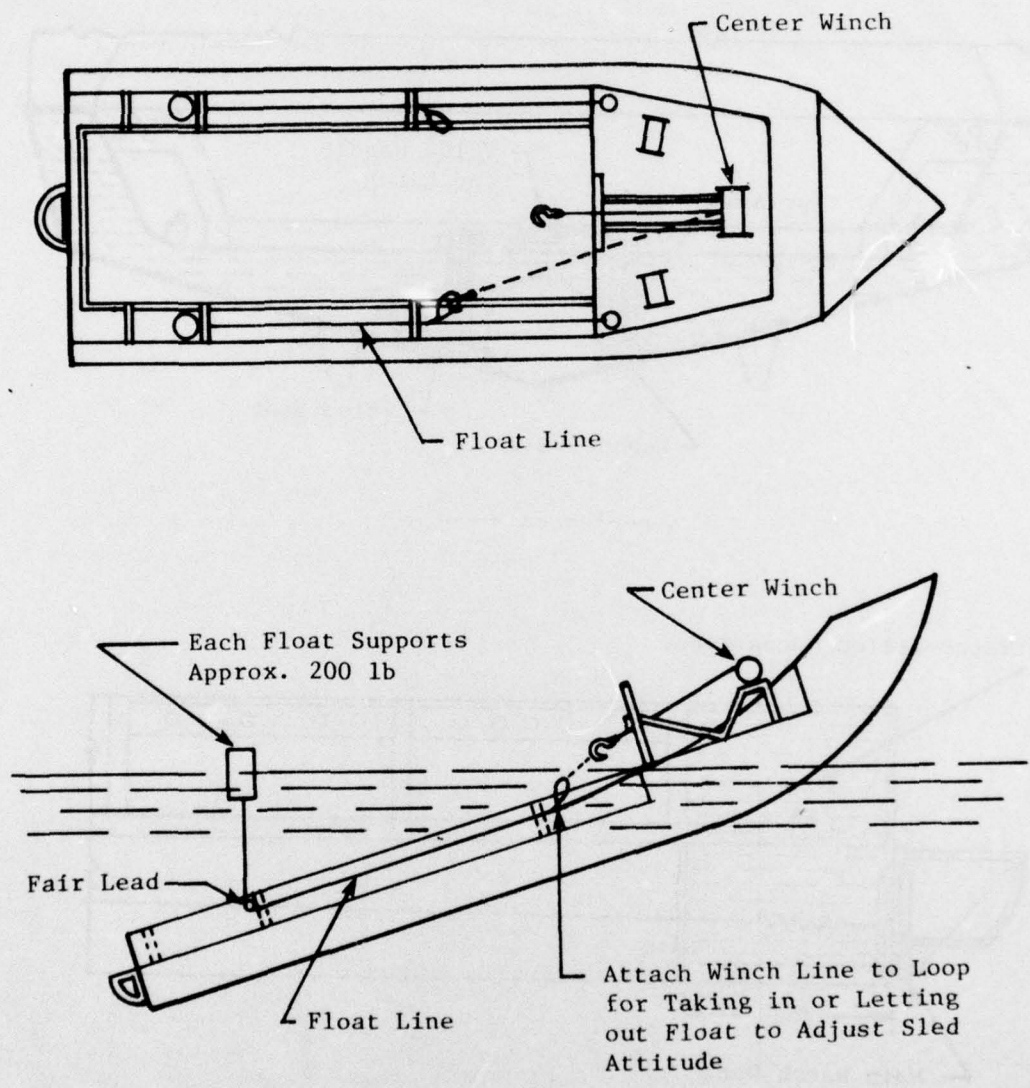

FIGURE 2. ATTITUDE ADJUSTMENT METHOD

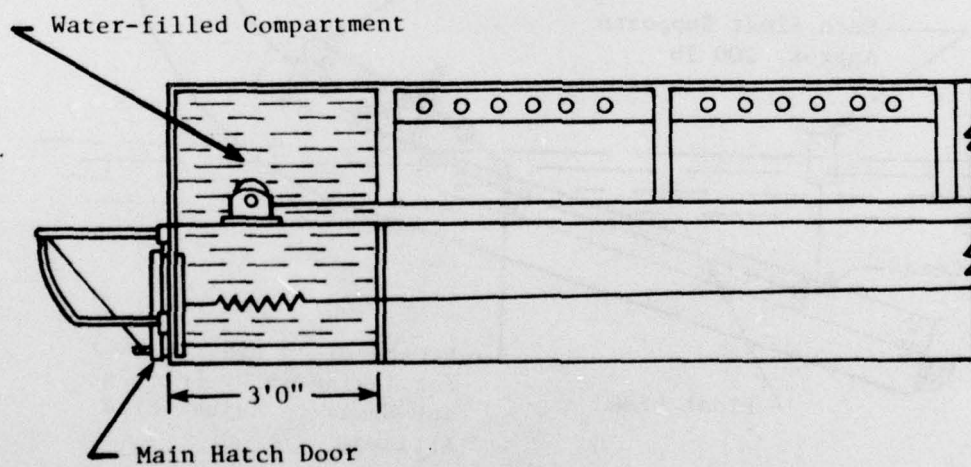
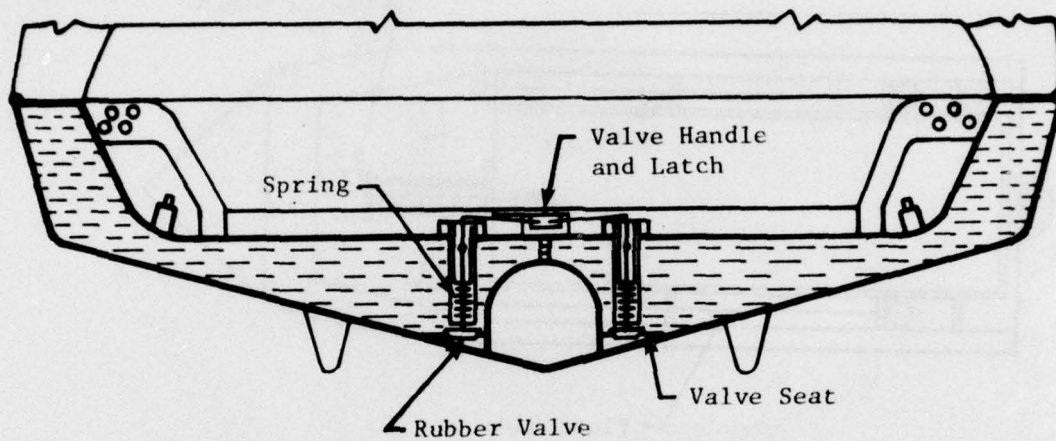

FIGURE 3. STERN BALLASTING SYSTEM

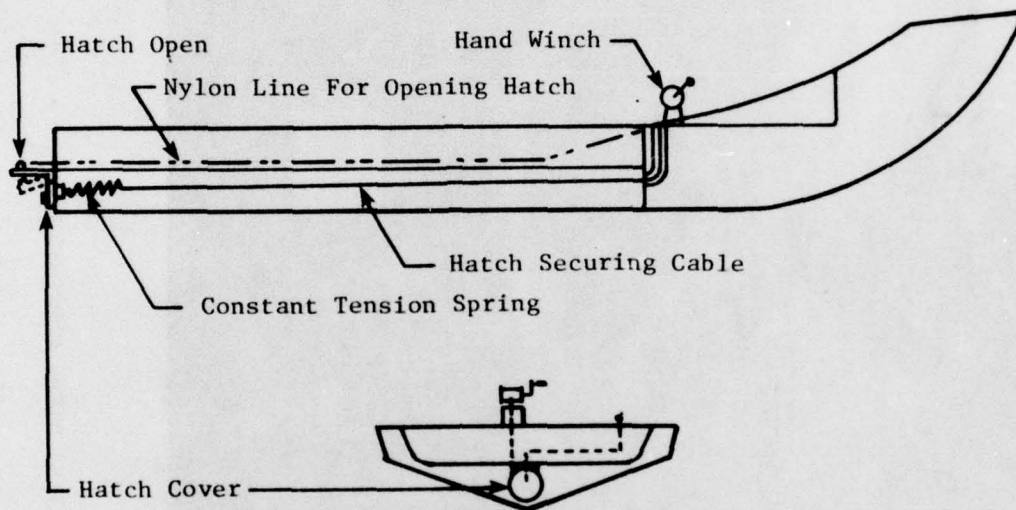

FIGURE 4. HATCH OPERATION

aside from the cargo area to the winch deck for opening the hatch cover from the winch deck. To convert from the wet condition to the dry condition, the sled is towed with the hatch open until completely drained. A man aboard the sled then closes and secures the stern hatch from the winch deck using the small hand winch.

#### DRAWINGS AND SPECIFICATIONS

Drawings and specifications of the developmental model sled were revised and supplemental drawings made to incorporate the design changes. Copies of the final drawings and specifications have been furnished the Coast Guard.

(Text Continued on Page 9)

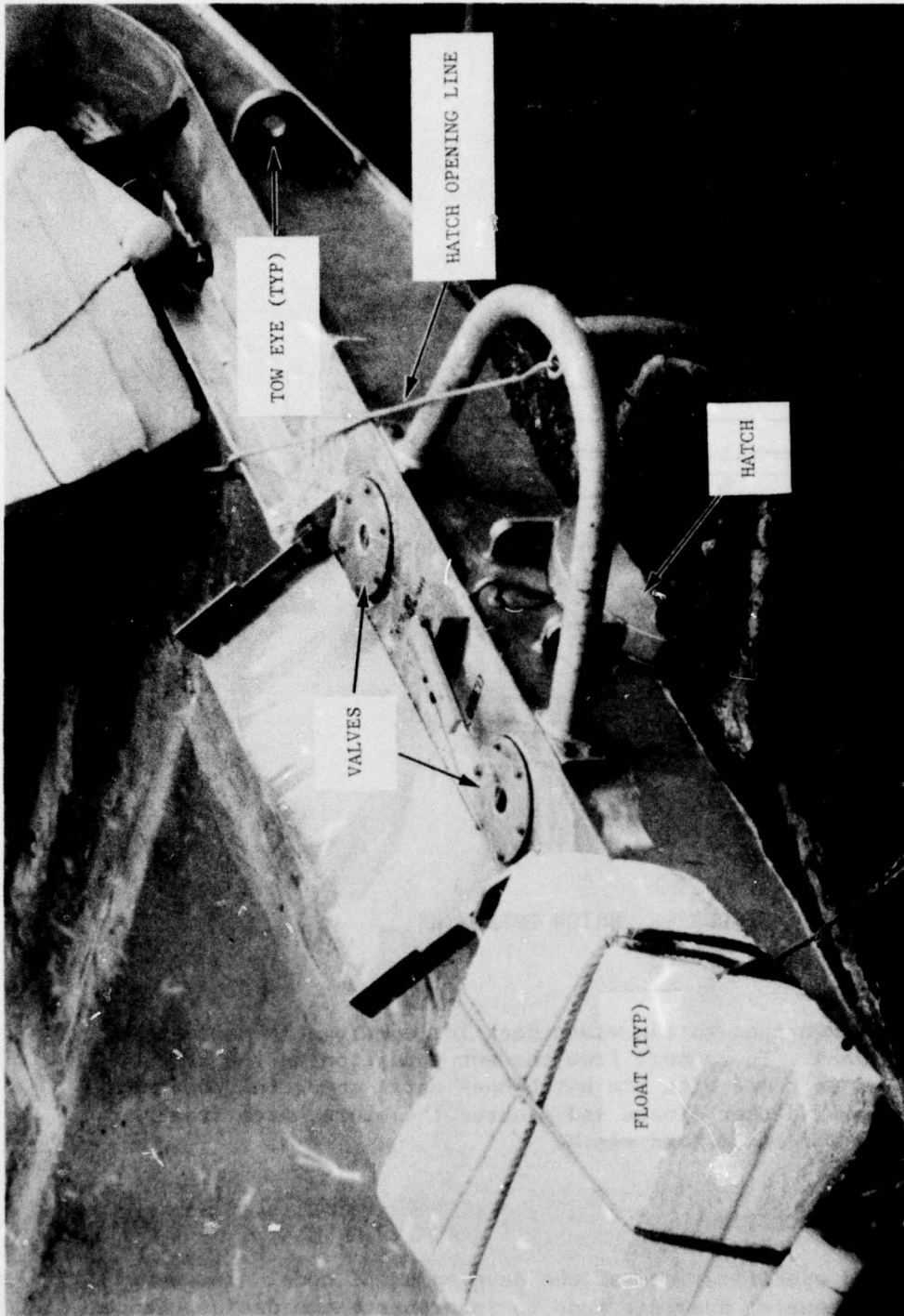

FIGURE 5. WET-DRY SLED STERN COMPONENTS

## FABRICATION

Approximately 1600 manhours were required to complete fabrication. Comparison of costs shows that fabrication of the wet-dry sled will cost \$4000 more than the original wet sled.

## TESTS

The objectives of the tests described herein were to determine and evaluate the characteristics and capabilities of the wet-dry planing sled and to examine the concept of dual tow.

All tests were performed by Coast Guard personnel. The 82-foot WPB, POINT LOBOS, and the 41-foot UTB stationed at Panama City were the tow boats. Coast Guard National Strike Force members from the Atlantic, Pacific, and Gulf teams manned the sled operations. A test log was kept by CWO Paul Sparrow, Officer-in-Charge, of the Strike Team. Tests were made at dockside and in St. Andrew Bay. Tow tension was measured at the POINT LOBOS towing bitt by a 10,000-pound load cell. Speed was calculated from the tow boat's rpm.

## DOCKSIDE

Dockside tests were made to determine weight, center of gravity, water lines, and to examine the operational procedures and performance of the stern hatch and stern compartment valve system.

The following properties of the empty sled were measured at dockside.

Air weight - 10,500 pounds

Longitudinal cg - 25 feet forward of transom

Water line - 0.5 feet above keel at transom and 1.5 feet above keel 25 feet forward of transom.

Exercises were run to familiarize the Strike Team with procedures and to test performance of the stern floats, stern ballasting system, and stern hatch operations, and to measure flooding time. No difficulty was experienced in operating the various systems but leakage occurred in the stern ballasting system, in the aft buoyancy compartments, and the time required to flood was excessive. Since these deficiencies would not impair the tow tests, corrective measures were postponed until completion of the tests.

## SINGLE TOW TESTS

The initial tow tests were made to determine operability of the stern hatch door and to check drainage time of the empty sled under tow. Towing commenced with the empty sled flooded and the stern hatch door open. Complete drainage of the sled occurred within 5 minutes. After drainage, the hatch door was closed and sealed by personnel aboard the sled. No leakage occurred at the stern hatch and the hatch door was easily operated.

The second tests were made to check operability of the stern hatch with a load on the sled, and to measure drainage time and tow tension of the loaded sled. Towing commenced with sled loaded with the Barrier equipment and in the flooded mode. Tow tension was measured from the tow boat's main tow bitt. A maximum tow tension of 5200 pounds occurred just prior to planing. Drainage was complete within 5 minutes. Stern hatch operated without difficulty.

Waterline measurements of the Barrier-loaded dry sled were 2.2 feet above the keel at the transom and 1.0 feet above the keel at a point 25 feet forward of the transom.

## DUAL TOW TESTS

Tows of the wet sled and the new wet-dry sled were made concurrently with one tow ship to examine the concept of tandem tow. Although only tandem tow was specified, side-by-side tow tests were included to compare operational characteristics. For the dual tow tests, the wet sled was loaded with one ADAPTS container and the wet-dry sled with the Barrier.

### Tandem Tow Tests

In the tandem tow configuration, the wet-dry sled was in the forward position and the wet sled towed from a bridle at the stern of the wet-dry sled (Figure 5). The tow line from the POINT LOBOS was 300 to 400 feet of 4-inch nylon (Figure 6) and between the two sleds was 250 feet of 3-inch nylon.

The first tandem tow test began with both sleds in the flooded mode. This configuration creates the maximum tow tension until both sleds are planing. The maximum tension during the test was 7200 pounds, recorded at a time just before planing. In other tandem tow tests, the stern hatch was closed so that the forward sled would not be flooded at the start of the tests. In this configuration, the maximum tension

(Text Continued on Page 12)

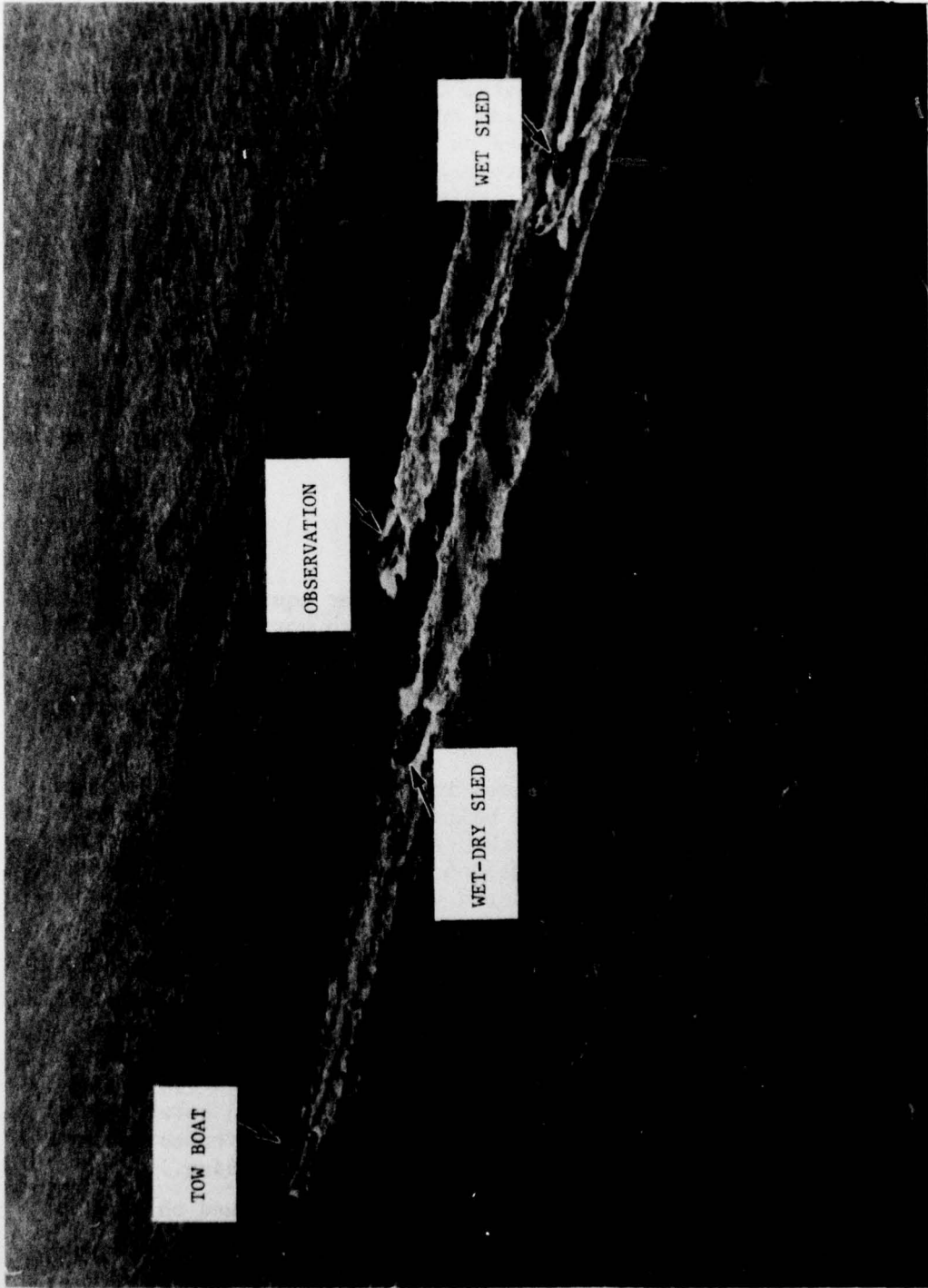

FIGURE 6. TANDEM TOW

recorded was 5500 pounds. No problems were noted in tow ship handling or maneuverability during the tandem tow tests.

#### Side-by-Side Tow Tests

Tests using a separate tow line from the tow ship to each of the two sleds were made to determine operational characteristics of the sleds and the tow ship in a side-by-side tow (Figure 7). Bridles were offset at each sled to divert the sleds from the tow course to maintain separation. The wet sled was diverted on the starboard side by shortening its port bridle leg by approximately 18 inches. The wet-dry sled was diverted on the port side by shortening its starboard bridle leg by approximately 18 inches. The wet sled was towed from the starboard quarter bitt with 250 feet of 3-inch nylon line and the wet-dry sled was towed from the main tow bitt with 300 to 375 feet of 4-inch nylon line. A load cell was used to measure tension of the wet-dry sled. The 18-inch offset in the bridles created a good separation of the two sleds at all speeds and during turns. The difference in tow line lengths also prevented any possibility of collision between the two sleds. The maximum tension measured on the diverted wet-dry sled was 3700 pounds. The wet-dry sled was towed in the dry mode during the tests. No ship handling difficulties were noted during the tests.

#### REPAIR

Upon completion of the tow tests, the Barrier equipment was unloaded and the wet-dry sled dry docked for repair work to correct the deficiencies found during the dockside tests. The deficiencies were:

1. Leakage in all four aft buoyancy compartments. This was stopped by rewelding in the buoyancy compartments.

2. Leakage around the ball valves in the stern ballasting system. The leakage around the valves in the ballasting system was caused by misalignment of the ball valves and the valve seats, also the urethane material used for the ball valves was too hard to allow the valve to seat properly. The valves were realigned with the valve seats and the valve material changed to rubber.

3. Excessive time required to flood the sled. As the sled floods, air is forced upward to the deck and to the gunwales. Holes were drilled in the inboard side of the 2-inch pipe that forms the outboard edges of the gunwales to allow air to flow through the pipes to the sled's bow and escape. Other holes were drilled in each frame underneath the cargo deck to prevent air from being trapped between frames and between longitudinal deck beams. Numerous holes were drilled in the frames and gunwale pipes to provide better air venting for faster flooding.

(Text Continued on Page 14)

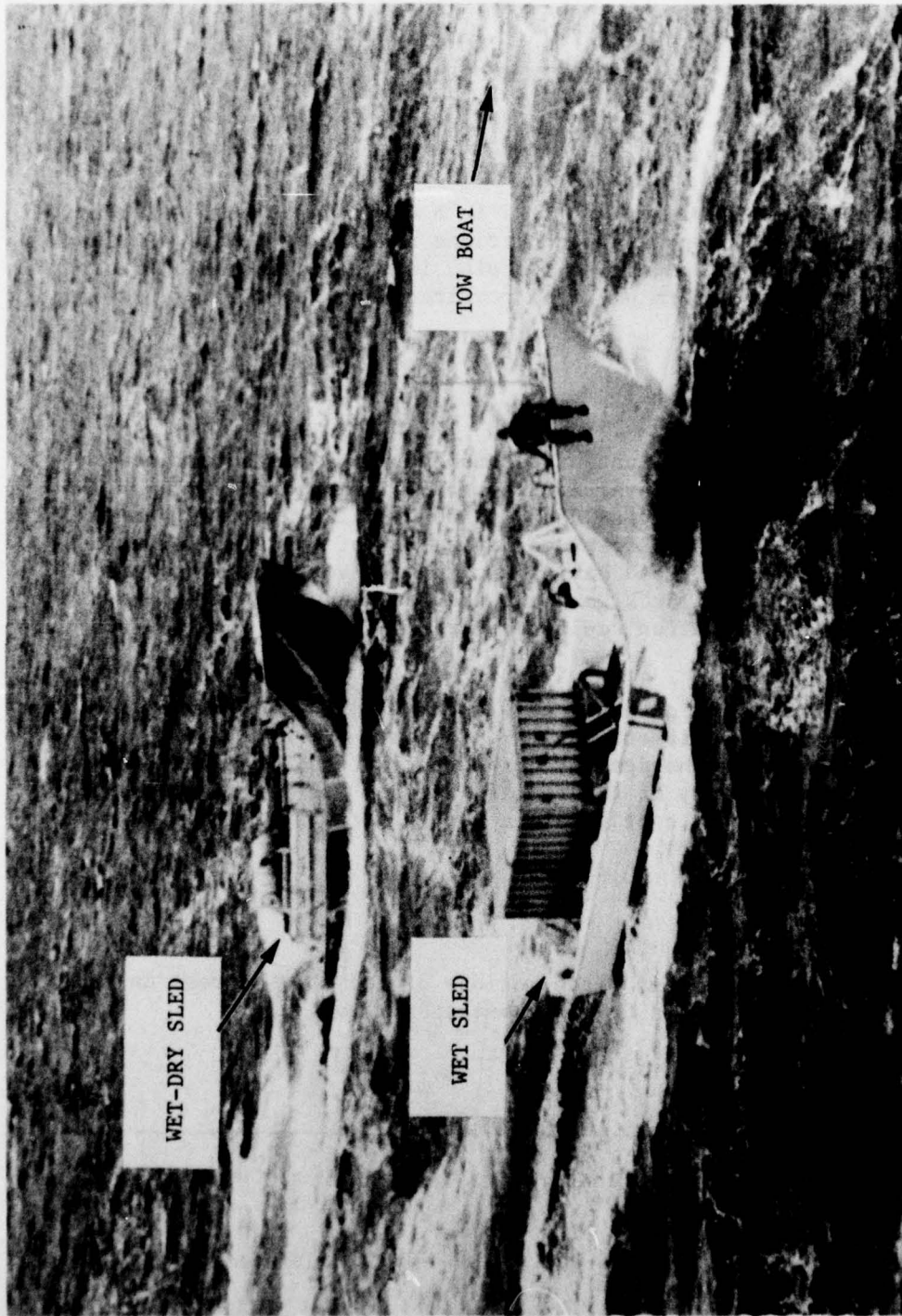

FIGURE 7. SIDE-BY-SIDE TOW

After completion of the repair work, tests confirmed that all leaks had been stopped and that flooding time was reduced to approximately 10 minutes.

## STABILITY STUDIES

### GENERAL

The stability of the wet-dry sled in a dry mode at rest was considered in relation to the possible conditions and use as a work platform. Performance tests have shown that the sled is extremely stable when planing. A stable platform would be required when the sled is used as a work platform.

### OVERTURN CONFIGURATIONS

Maximum angles of inclination before overturn were determined by a simple method outlined in *Naval Architecture of Planing Hulls*<sup>(1)</sup>. The method does not provide precise data, so the results are only general and are conservative. An extreme configuration of the sled in a dry mode with a 17,000-pound load having a composite vertical center of gravity 4 feet above the deck was selected for study. It was determined that the configuration would overturn if inclined more than 23 degrees (Figure 8).

A second configuration examined was the sled in a dry mode with the 17,000-pound Barrier equipment having a composite vertical center of gravity 1.8 feet above the deck. The buoyancy of the load and the effect of the shape and buoyancy of the forward section was not considered. It was determined that this configuration would overturn if inclined more than 41 degrees (Figure 8).

### COMPUTATIONS

Computation of roll and pitch motions of the sled at rest in sea state 3 were made by NCSL's Hydromechanics Division.

---

<sup>(1)</sup> Lord, Lindsay, *Naval Architecture of Planing Hulls*, Cornell Maritime Press, 1963.

(Text Continued on Page 16)

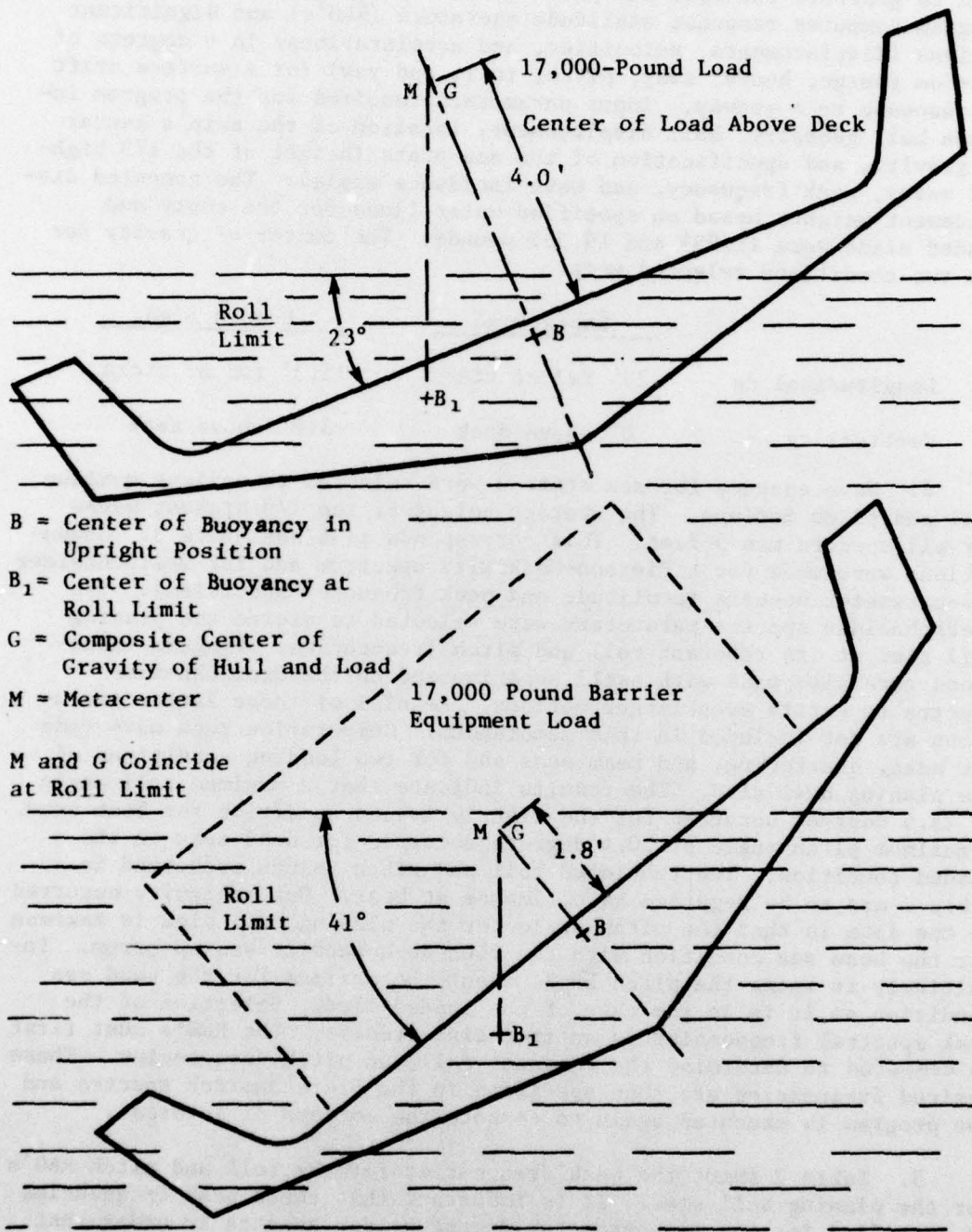

FIGURE 8. MAXIMUM SAFE ROLL ANGLE

1. Program RMTRADE (NCSL modification of NCEL's RELMO program) was used to generate the roll and pitch motions presented in Table 1. This program computes response amplitude operators (RAO's) and significant motions (displacements, velocities, and accelerations) in 6 degrees of freedom (surge, heave, sway, pitch, roll, and yaw) for a surface craft in response to a seaway. Input parameters required for the program include hull geometry, hull displacement, location of the ship's center of gravity, and specification of the sea state (height of the 1/3 highest waves, peak frequency, and wave incidence angle). The computed displacement weights based on specified water lines for the empty and loaded sleds were 11,953 and 19,352 pounds. The center of gravity for the two conditions selected were:

	<u>Empty Sled</u>	<u>Loaded Sled</u>
Longitudinal cg	25' fwd of stern	15.3' fwd of stern
Vertical cg	0' above deck	3.8' above deck

2. Wave spectra for sea state 3 were selected to achieve maximum roll and pitch motions. The average height of the 1/3 highest waves for all spectra was 5 feet. This corresponds to a sea state 3. Computations were made for a Pierson-Moskowitz spectrum and for Bretschneider two-parameter spectra (amplitude and peak frequency specified). The Bretschneider spectra parameters were selected to excite the planing hull sled at its resonant roll and pitch frequencies. Program executions were also made with swell superimposed on the Bretschneider spectra to excite even larger motions. Results of these latter executions are not included in this memorandum. Computation runs were made for head, quartering, and beam seas and for two loading conditions of the planing hull sled. The results indicate that a maximum roll angle of 25.5 degrees occurred for the lightly loaded condition for beam seas. A maximum pitch angle of 10.4 degrees occurred for head seas in the loaded condition. The tabulated roll and pitch values presented in Table 1 are to be regarded as estimates at best. One ambiguity occurred in the data in that the pitch angle for the planing hull sled is maximum for the beam sea condition with the Pierson-Moskowitz sea spectrum. Intuitively it seems the pitch angle should be maximum for the head sea condition as it is in the case of the loaded sled. Selection of the peak spectral frequencies is an iterative process. The RAO's must first be computed to determine the resonant roll and pitch frequencies. These desired frequencies are then specified in the Bretschneider spectra and the program is executed again to compute the motions of interest.

3. Table 2 shows the peak frequencies for the roll and pitch RAO's for the planing hull sled. It is important that these peak frequencies be specified for the two-parameter Bretschneider spectra in order that the computations yield maximum roll and pitch values.

(Text Continued on Page 18)

TABLE 1

COMPUTED ROLL AND PITCH VALUES FOR PLANING HULL SLED

Angles & Spectra of Interest	Sled Load					
	Empty <sup>(2)</sup>			Loaded <sup>(3)</sup>		
	Head	Quar	Beam	Head	Quar	Beam
Pitch Angle (degrees) (Pierson Moskowitz Spectrum)	6.690	5.392	7.553	7.565	5.955	2.354
Roll Angle (degrees) (Pierson Moskowitz Spectrum)	0.000	6.251	10.93	0.000	2.581	4.294
Pitch Angle (degrees) (Bretschneider @ Pitch Peak)	8.712 (1.7)*	6.800 (2.5)	3.593 (2.5)	10.40 (1.7)	6.560 (2.8)	2.561 (2.8)
Roll Angle (degrees) (Bretschneider @ Roll Peak)	0.000 (1.7)	9.899 (2.5)	25.53 (2.5)	0.000 (1.7)	4.203 (2.8)	8.458 (2.8)

\*Number in parentheses is specified peak radian frequency of spectrum nearest RAO resonant frequency.

(2) Empty Planing Hull Sled = 11,593 pounds.

(3) Barrier Load on Planing Hull Sled = 19,352 pounds.

TABLE 2

RADIAN FREQUENCY WHERE RAO'S FOR PLANING HULL SLED PEAK

Angles & Spectra of Interest	Sled Load					
	Empty <sup>(2)</sup>			Loaded <sup>(3)</sup>		
	Head	Quar	Beam	Head	Quar	Beam
Pitch Angle (Bretschneider @ Pitch Peak)	1.9	2.2	1.7	2.0	2.3	2.3
Roll Angle (Bretschneider @ Roll Peak)	-	2.5	2.9	-	2.8	2.9

See footnotes for Table 1.

## BOAT RESCUE AND BUOY RECOVERY

In April 1976, NCSL staged a boat rescue and buoy recovery to demonstrate other practical uses of the planing hull sled. The work was not a part of the Coast Guard's FSD task.

A 22-foot boat was used as the simulated boat in distress. The POINT LOBOS towing the original FSD sled performed the rescue operations (Figures 9 and 10). The sled was brought alongside the drifting boat and crewmen attached a line from the sled to the bow of the boat. After the line was attached, the tow boat took a slight strain on the line to align the boat and the sled. The boat was winched in between the gunwales of the submerged sled into a position where its stern was in approximate alignment with the sled's stern. As the POINT LOBOS increased speed and planing was achieved, the boat settled to the sled's deck.

A 5 by 11 foot lighted Coast Guard buoy was recovered in the same manner (Figures 11 and 12).

## CONCLUSIONS

The wet-dry planing sled developed under the amendment provides a versatile and useful addition to the Coast Guard's equipment. In addition to its capability for fast surface delivery of pollution control equipment, the wet-dry sled can be effective in rescue operations, firefighting at sea, recovery of equipment at sea, and buoy tending.

Construction cost of the wet-dry sled was approximately \$4000 more than the wet sled due to the additional labor, parts, and equipment required to provide the dry mode capability and the modifications to improve performance.

Operational and handling procedures are simple and require no special training; maintenance requirements are minimal.

The stern ballasting system provides a means to trim the empty wet-dry sled. The bow-down attitude causes the bow of the unballasted empty sled to dip into the sea when under tow. The better trim angle of the ballasted sled will relieve the plunging action. Operational tests will be required to determine the effectiveness of the improved trim condition.

(Text Continued on Page 23)

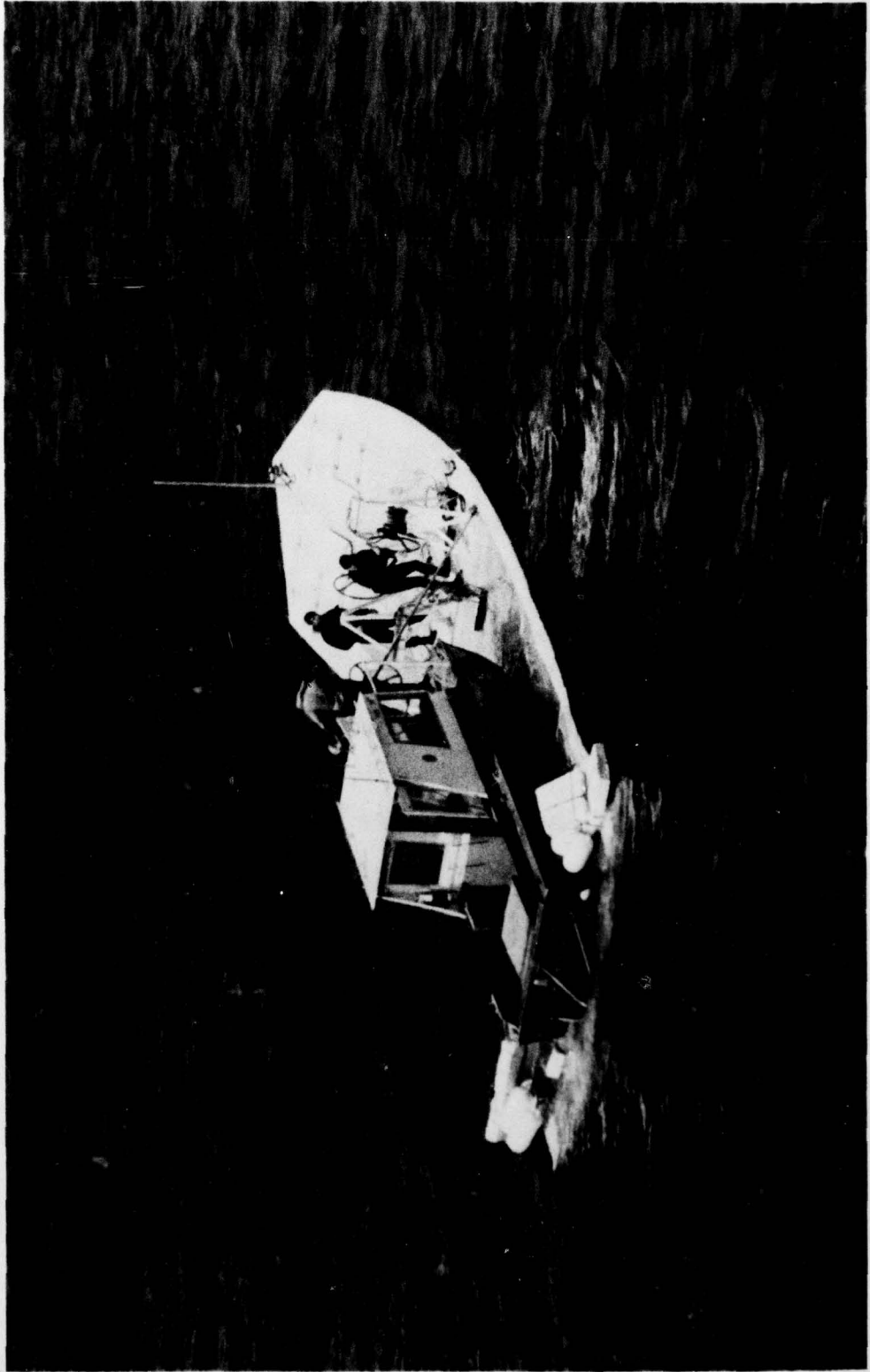

FIGURE 9. LOADING BOAT IN SLED

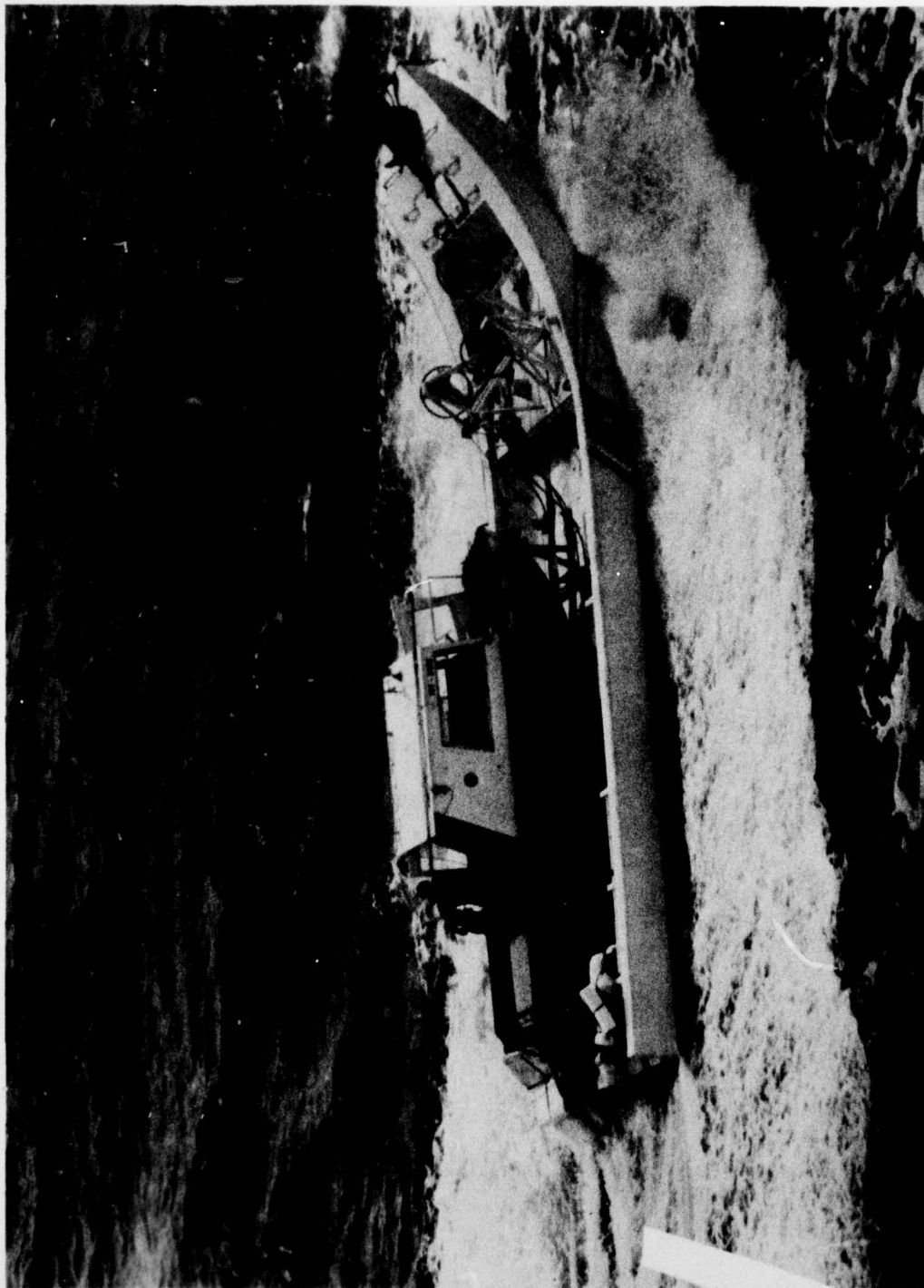

FIGURE 10. SLED CARRYING BOAT



FIGURE 11. LOADING BOUY IN SLED



FIGURE 12. SLED CARRYING BUOY

The limited stability calculations do not provide sufficient information to verify the safety of operations aboard the dry sled at rest. However, the calculations provide general concept of the reactions and roll limits. Stability calculations indicate that in a sea state 3 condition with the dry sled at rest in a beam sea, a maximum roll angle of 25.5 degrees would occur. Other calculations show that the dry sled at rest with a similar load would require a 41 degree roll angle to overturn.

Tests have shown that dual tow in calm seas is feasible and an effective means to increase load carrying capabilities of the FSD system. The 7200-pound maximum tow-bar pull required for dual tow is well within the capabilities of an 82-foot WPB. Dual tow does not adversely affect the tow ship's maneuverability. Handling and rigging operations are not difficult. The side-by-side tow configuration provides a shorter tow length but a wider tow path.