

AD A 050246

2
BS

NPS55-77-32

NAVAL POSTGRADUATE SCHOOL

Monterey, California

AD No. —
DDC FILE COPY



DDC
RECEIVED
FEB 22 1978
D

The Effect of Modeling Depth on
Reliability Prediction for Systems Subject
to a Phased Mission Profile
by
J. D. Esary
July 1977

Approved for public release; distribution unlimited

NAVAL POSTGRADUATE SCHOOL
Monterey, California

Rear Admiral Isham Linder
Superintendent

Jack R. Borsting
Provost

Reproduction of all or part of this report is authorized.

This report was prepared by:

J. D. Esary

J. D. Esary
Professor
Department of Operations Research

Reviewed by:

Michael G. Sovereign

Michael G. Sovereign, Chairman
Department of Operations Research

W. M. Fossom

Robert R. Fossom
Dean of Research

Unclassified

SECURITY CLASSIFICATION OF THIS PAGE (When Data Entered)

REPORT DOCUMENTATION PAGE		READ INSTRUCTIONS BEFORE COMPLETING FORM	
1. REPORT NUMBER NPS55-77-32	2. GOVT ACCESSION NO.	3. RECIPIENT'S CATALOG NUMBER	
4. TITLE (and Subtitle) The Effect of Modeling Depth on Reliability Prediction for Systems Subject to a Phased Mission Profile		5. TYPE OF REPORT & PERIOD COVERED Technical Repts.	
6. AUTHOR(s) J. D. Esary		7. CONTRACT OR GRANT NUMBER(s)	
8. PERFORMING ORGANIZATION NAME AND ADDRESS Naval Postgraduate School Monterey, California 93940		9. PROGRAM ELEMENT, PROJECT, TASK AREA & WORK UNIT NUMBERS	
10. CONTROLLING OFFICE NAME AND ADDRESS Naval Postgraduate School Monterey, California 93940		11. REPORT DATE July 1977	
12. MONITORING AGENCY NAME & ADDRESS (if different from Controlling Office)		13. NUMBER OF PAGES 25 (12) / 34 p	
		14. SECURITY CLASS. (of this report) Unclassified	
		15a. DECLASSIFICATION/DOWNGRADING SCHEDULE	
16. DISTRIBUTION STATEMENT (of this Report) Approved for public release; distribution unlimited			
17. DISTRIBUTION STATEMENT (of the abstract entered in Block 20, if different from Report)			
18. SUPPLEMENTARY NOTES			
19. KEY WORDS (Continue on reverse side if necessary and identify by block number) Reliability Prediction; Phased Missions; Phased Mission Profiles.			
20. ABSTRACT (Continue on reverse side if necessary and identify by block number) The term "phased mission profile" describes a situation in which the factors that influence the longevity of a system change in the course of a sequence of distinct, successive periods of time which are the mission "phases." Phased mission profiles tend to be associated with more general phased missions, in which there can also be changes in the system configuration that is relevant to mission success, but many systems with a stable configuration are exposed to phased mission profiles.			

DD FORM 1 JAN 73 1473

EDITION OF 1 NOV 65 IS OBSOLETE
S/N 0102-014-6601

Unclassified

SECURITY CLASSIFICATION OF THIS PAGE (When Data Entered)

251450

over
elf

20 Continued.

Predictions of the probability of mission success for a system typically result from combining predicted probabilities of mission success for its components according to a logic model for the system's configuration. We investigate the effect that the depth to which the logic model is carried has on predictions, when the predictions at the component level are made using a standard methodology.

White Section	<input checked="" type="checkbox"/>
Buff Section	<input type="checkbox"/>
UNCLASSIFIED	<input type="checkbox"/>
CONFIDENTIAL	<input type="checkbox"/>
MISSION AVAILABILITY CODES	
AVAIL. AND/OR SPECIAL	
A	

REC'D
FEB 22 1978
REGULATED
D

The Effect of Modeling Depth on Reliability
Prediction for Systems Subject to a Phased Mission Profile

J. D. Esary^{*}

start Abstract
below this line →

Abstract. The term "phased mission profile" describes a situation in which the factors that influence the longevity of a system change in the course of a sequence of distinct, successive periods of time which are the mission "phases." Phased mission profiles tend to be associated with more general phased missions, in which there can also be changes in the system configuration that is relevant to mission success, but many systems with a stable configuration are exposed to phased mission profiles.

Predictions of the probability of mission success for a system typically result from combining predicted probabilities of mission success for its components according to a logic model for the system's configuration. We investigate the effect that the depth to which the logic model is carried has on predictions, when the predictions at the component level are made using a "standard" methodology.

1. Introduction. Reliability predictions for complex systems typically begin with predictions of the probabilities of mission success for the components in a system. Then the component predictions are combined in accordance with a logic model which describes how the components interact in the system, e.g. a block diagram or a fault tree. The result is a predicted mission success probability for the system. Safety predictions follow a mathematically equivalent pattern which predicts the probability of occurrence for a catastrophic event by using a

^{*} Department of Operations Research, Naval Postgraduate School, Monterey, CA 93940. This research was supported by the Office of Naval Research (NR 042-300).

logic model to combine predicted occurrence probabilities for various contributory events. In both cases it is reasonable to expect that the validity of the prediction process can be affected by the *depth* of the logic model, i.e. by the level of detail to which the block diagram or fault tree is developed, and at which "component" predictions are introduced.

The purpose here is to investigate an optimistic bias which can arise from using a logic model which is too shallow in conjunction with the standard methodologies for making component level predictions from historical experience, available test data, or similar sources. The bias in question can be illustrated by a simple example.

Example 1.1. A device D (perhaps an actuator or a control) will be required to complete two identical, brief cycles of operation during the course of a mission. Previous experience with the device in a similar service environment is confined to a single operational cycle and indicates a .99 probability that the device will function once. The duration of the operational cycles is so short that hardware aging is not expected to occur. Extrapolating that the probability that the device will function a second time is another .99 leads to a predicted success probability of $(.99)^2 = .9801$ for two cycles of operation, as is indicated in Figure 1.1.

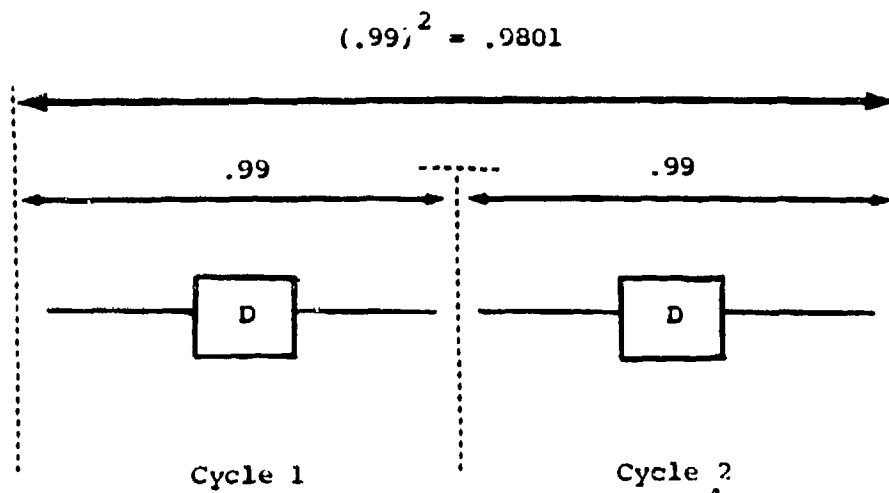

FIGURE 1.1

However, if viewed in greater detail, the device turns out to be a construct of two identical components, 1 and 2, that operate independently and in parallel. Its single cycle reliability of .99 results from a single cycle success probability of .9 for each component, i.e. $.9 \vee .9 = .99$, where $p_1 \vee p_2 = 1 - (1-p_1)(1-p_2) = p_1 + p_2 - p_1p_2$ is a convenient notation for the reliability of a system with two independent components that function in parallel with reliabilities p_1 and p_2 (see Figure 1.2).

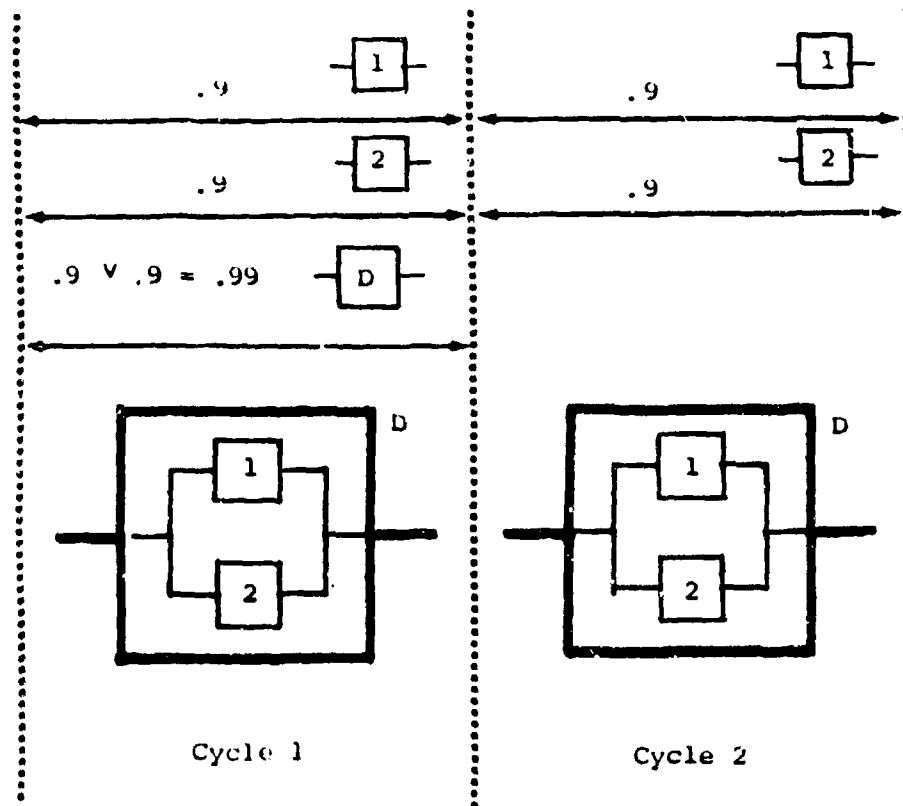

FIGURE 1.2

Then it can be recognized that the device will complete two operational cycles if either component 1 or component 2 does so. Extrapolating one cycle survival probabilities at the new level of component detail leads to a predicted probability $(.9)^2 = .81$ that component 1 will survive two cycles, the same probability that component 2 will survive two cycles, and to a predicted probability $.81 \vee .81 = .9639$ that the device will survive two cycles, as in Figure 1.3.

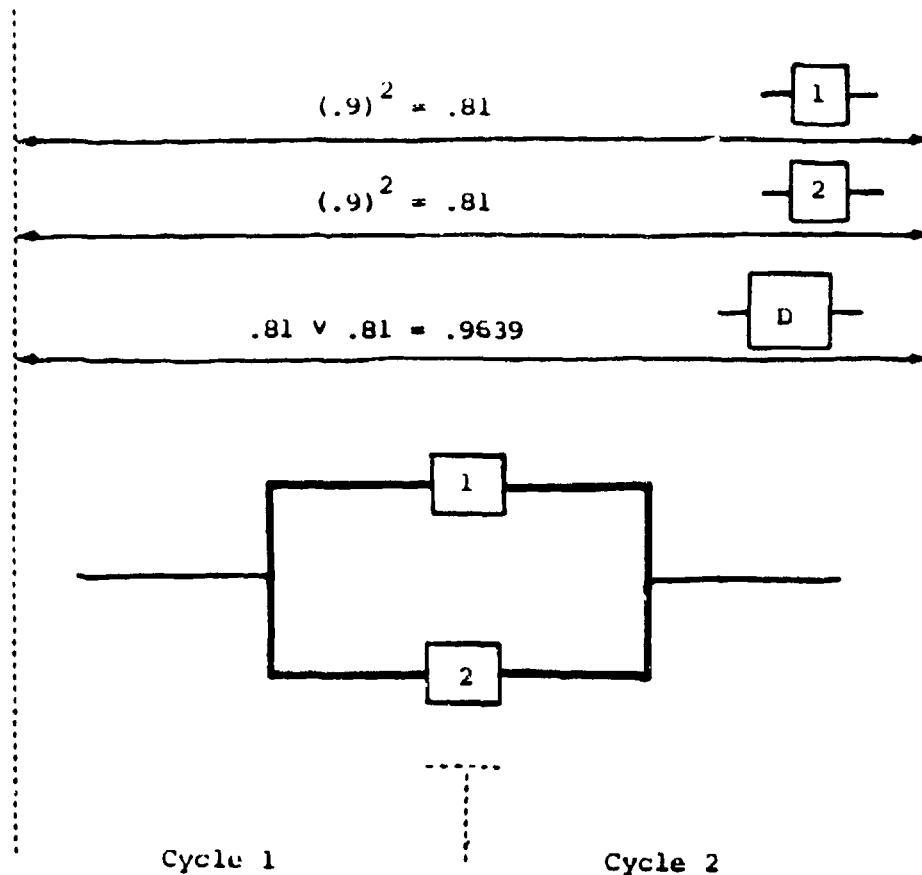

FIGURE 1.3

In this example the assumption that there will be no hardware aging over the course of two operational cycles has been incorporated with experience at two different modeling depths. The prediction based on the more detailed model is the more conservative. □

The scenario considered in Example 1.1 is an almost trivial example of a phased mission. It has successive periods of time in which

environmental stresses are altered or repeated which can be regarded as mission phases, but the logic model for the system is the same in each period. More general phased missions can involve successive epochs of time in which there are changes in the logic model that is relevant to system success as well as in the applied environmental stresses. For such missions the depth of the logic models employed in making reliability predictions can have an effect similar to that noted in Example 1.1.

The pioneering work on reliability analysis for phased missions was motivated by the need to predict mission success and crew safety for manned spaceflights. Rubin [6, 1964] and Schmidt and Weisberg [7, 1966] described an approximate, but conservative, method of making reliability predictions for phased missions. Certain weapons systems are designed to perform phased missions. Esary and Ziehms [4, 1975] studied a transformation technique that, at least in principle, reduces the prediction problem for a phased mission to that for a single-phase mission. Ziehms [9, 1975] compared a variety of approximate methods for making phased mission reliability predictions, and identified those which are conservative and relatively the most accurate. Bell [2, 1975] considered a class of multi-objective phased missions in which sub-missions diverge from a main mission, and described methods for predicting success probabilities for single objectives and composite figures of merit for combinations of objectives. Bell also considered allowing for an "operational readiness" phase in making predictions. This is a preliminary phase of indeterminate duration, prior to the inception of

the active mission, during which components can be repaired if they fail in an effort to maintain the readiness of the system. Pilnick [5, 1977] emphasized the use of graphical techniques in conducting an expository analysis of a hypothetical mission proposed by Bell.

Recently Burdick, Fussell, Rasmuson, and Wilson [3, 1977] have discussed the analysis of phased missions from the safety perspective, using fault trees to represent the relevant logic models, and considering exact, and selected approximate, methods for making predictions. They suggest, accompanied by examples, possible applications in predicting the safety of nuclear reactors.

The papers just cited contain assorted examples of phased missions, and discuss some of the computational practicalities involved in their analysis. These papers are focused on a proper accounting for shifts in system configuration from phase to phase of a mission, under the assumption that the reliabilities of the components throughout the course of the mission have been correctly established.

Attention here is confined to a different aspect of the phased mission problem, the origins of the bias noted in Example 1.1 and the effect it has on predicted probabilities for mission success. We will seek to characterize those devices whose reliability over a phased environmental profile can be predicted by "standard" methods, and then to establish the modeling depth at which such predictions can be introduced into the analysis of a phased mission. For the present, only systems whose configuration is stable throughout the mission are considered.

2. Standard reliability predictions for phased mission profiles.

Any mission that is contemplated for a device will expose it to one or more service environments. From the physical and human factors point of view, a service environment for a device is an amalgam of the stresses (temperature, vibration) and other factors (corrosion, careless operation) that influence its longevity. From the stochastic point of view, the impact of a service environment on a device can be summarized by a probability distribution for the amount of time the device will survive if exposed in that environment.

We will assume that a fully up device introduced into a service environment e has a random, nonnegative time to failure T_e . For our purposes the probability distribution of T_e can conveniently be described by a survival function

$$(2.1) \quad \bar{F}_e(t) = P[T_e > t], \quad t \geq 0,$$

which gives the probability that the device will survive a mission of whatever duration t in environment e . Or, in some cases, the distribution of T_e can be described by a failure rate for the device in environment e , i.e. by a nonnegative function $r_e(t)$, $t \geq 0$, such that

$$(2.2) \quad \bar{F}_e(t) = e^{-\int_0^t r_e(s) ds}, \quad t \geq 0.$$

It is usually the case that there is a multiplicity of service environments in which a device may be used. We will suppose that a device can be exposed to a range E of possible service environments e , each characterized by a survival function \bar{F}_e for the device in that environment, or perhaps by a failure rate λ_e .

For many devices a typical mission requires exposure, for various periods of time, to a sequence of distinct service environments. For such a device, a *phased mission profile* will be a sequence e_1, e_2, \dots, e_m of environments to which it is successively exposed, accompanied by a sequence d_1, d_2, \dots, d_m of times which are the durations of the exposures in each environment.

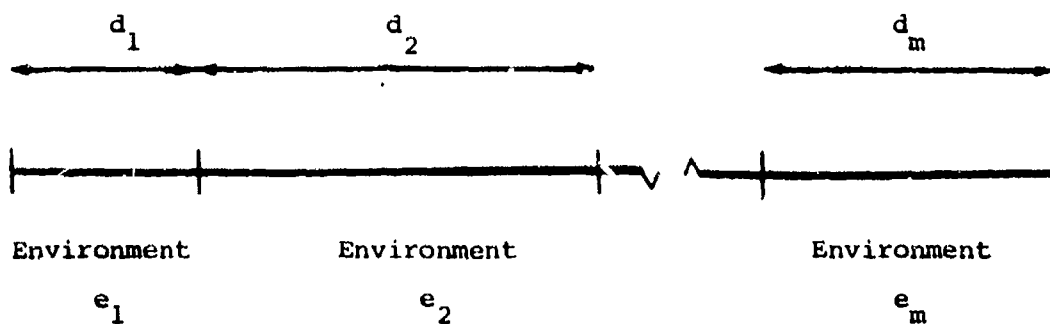

There is often a need to predict the probability that a device will operate successfully throughout a phased mission profile, using knowledge of its reliability in each of the service environments involved as a point of departure. A basic motivation for this paper is the presumption that there is a widely used (standard) methodology for doing this which is illustrated by the following example.

Example 2.1. A device (perhaps a generator) has two modes of operation, active and passive. Its failure rate in the passive mode is believed to be a constant λ_1 failures/hr. Its failure rate in the active mode is believed to be a constant λ_2 failures/hr (presumably $\lambda_2 > \lambda_1$).

For a mission in which d_1 hours of passive operation are followed by d_2 hours of active operation, our standard methodology draws the failure rate profile shown in Figure 2.1.

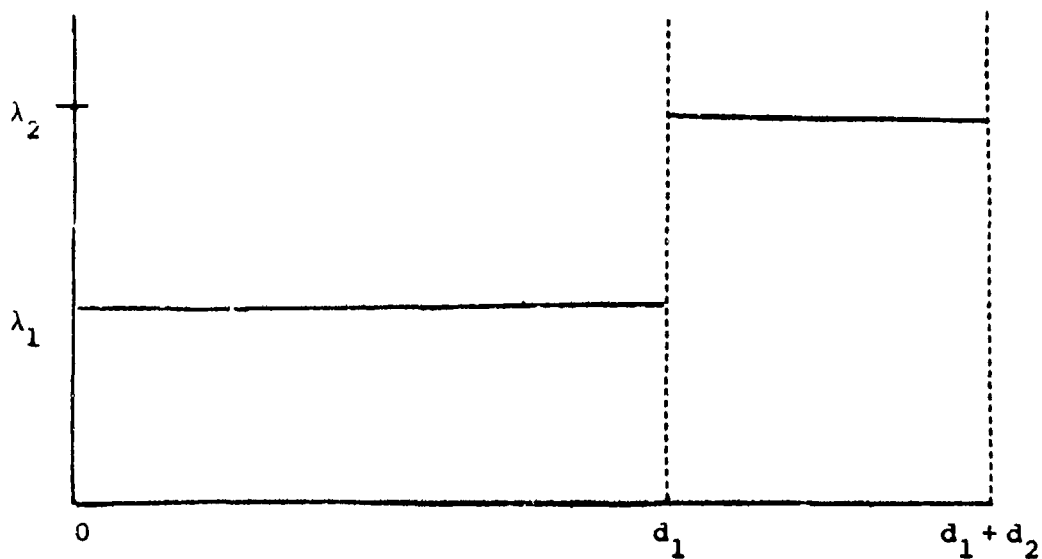

FIGURE 2.1

Then in keeping with equation (2.2), the area $\lambda_1 d_1 + \lambda_2 d_2$ under the failure rate curve is found, and the probability of success for the mission is predicted to be $e^{-(\lambda_1 d_1 + \lambda_2 d_2)}$.

Equivalently, the probability of mission success is predicted to be

$$\bar{F}_1(d_1) \bar{F}_2(d_2) = e^{-\lambda_1 d_1} \cdot e^{-\lambda_2 d_2} .$$

where $\bar{F}_1(t) = e^{-\lambda_1 t}$ and $\bar{F}_2(t) = e^{-\lambda_2 t}$ are the survival functions for the device in the passive and active operating modes. \square

The reader can consider his own variations on the scenario of Example 2.1, involving shifts in stresses, repeated duty cycles, or similar features, to see if he agrees with the general description of feasible practice contained in the following paragraph.

In general, without requiring the existence of failure rates, we will say that the *standard method* for predicting the reliability of a device over a phased mission profile is to equate the probability of mission success, i.e. the probability that each period of exposure to each service environment is survived in turn, to the product of the probabilities that each environmental exposure would be survived if undertaken separately. For the phased mission profile $e_1, d_1; e_2, d_2; \dots; e_m, d_m$ we can express the standard prediction by writing

$$(2.3) \quad \bar{F}(d_1, d_2, \dots, d_m) = \bar{F}_1(d_1) \cdot \bar{F}_2(d_2) \cdot \dots \cdot \bar{F}_m(d_m) ,$$

where $\bar{F}(d_1, d_2, \dots, d_m)$ is notation for the probability of surviving the sequence of exposures of durations d_1, d_2, \dots, d_m , and \bar{F}_j is a shortened notation for the survival function of the device in environment e_j , $j = 1, \dots, m$.

For example, the Review Committee for this manuscript has indicated that the standard method is essentially that implemented by the KITT-2 computer code in treating phased mission profiles. See Veseley and Narum [8, 1970].

3. Degradable and nondegradable devices. The standard prediction method considered in Section 2 assumes that a device enters each new service environment with its survival potential unimpaired. Although failure is permitted in the course of a mission, deterioration is not.

More formally, we will say that a device is *nondegradable* if

$$(3.1) \quad \bar{F}(d_1, d_2) = \bar{F}_1(d_1) \bar{F}_2(d_2)$$

for all periods of exposure d_1, d_2 to all service environments e_1, e_2 in E the range of possible environments to which the device may be exposed. As an alternative, a device is *degradable* if

$$(3.2) \quad \bar{F}(d_1, d_2) \leq \bar{F}_1(d_1) \bar{F}_2(d_2)$$

for all exposures d_1, d_2 and environments e_1, e_2 in E . The inclusion of the class of nondegradable devices within the class of degradable devices as a boundary case reflects a convention that has proved convenient in treating similar notions.

Systems formed from nondegradable components can be either nondegradable or degradable, as is shown by the following examples.

Example 3.1. A two component series system functions as long as both its components function. If the components fail independently,

then $\bar{F}(d_1, d_2) = \bar{G}(d_1, d_2) \bar{H}(d_1, d_2)$ and $\bar{F}_j(d_j) = \bar{G}_j(d_j) \bar{H}_j(d_j)$,
 $j = 1, 2$, where \bar{F} denotes a survival function pertaining to the system
and \bar{G}, \bar{H} denote survival functions pertaining to the components.

If the components in a two component series system are nondegrad-
able, then

$$\begin{aligned} \bar{F}(d_1, d_2) &= \bar{G}(d_1, d_2) \bar{H}(d_1, d_2) \\ &= \bar{G}_1(d_1) \bar{G}_2(d_2) \cdot \bar{H}_1(d_1) \bar{H}_2(d_2) \\ &= \bar{G}_1(d_1) \bar{H}_1(d_1) \cdot \bar{G}_2(d_2) \bar{H}_2(d_2) \\ &= \bar{F}_1(d_1) \bar{F}_2(d_2) \end{aligned}$$

for all d_1, d_2 and e_1, e_2 in E , the range of service environments
for the system. Thus the system is nondegradable. There is a tacit,
but reasonable assumption made that the range of service environments
for the system is contained in the range of service environments for
each of its components.

A two component parallel system functions as long as either of its
components functions. If the components fail independently, then
 $\bar{F}(d_1, d_2) = \bar{G}(d_1, d_2) \vee \bar{H}(d_1, d_2)$ and $\bar{F}_j(d_j) = \bar{G}_j(d_j) \vee \bar{H}_j(d_j)$, $j = 1, 2$.

If the components in a two component parallel system are nondegrad-
able, then

$$\begin{aligned} \bar{F}(d_1, d_2) &= \bar{G}(d_1, d_2) \vee \bar{H}(d_1, d_2) \\ &= \bar{G}_1(d_1) \bar{G}_2(d_2) \vee \bar{H}_1(d_1) \bar{H}_2(d_2) \\ &\leq \{\bar{G}_1(d_1) \vee \bar{H}_1(d_1)\} \{\bar{G}_2(d_2) \vee \bar{H}_2(d_2)\} \\ &= \bar{F}_1(d_1) \bar{F}_2(d_2) \end{aligned}$$

for all d_1, d_2 and e_1, e_2 in E (for the system). Thus the system is degradable. The crucial step in the argument depends on the inequality $p_1 p_2 \vee q_1 q_2 \leq (p_1 \vee q_1)(p_2 \vee q_2)$, where p_1, p_2, q_1, q_2 are probabilities. This inequality can be verified by inspection if block diagrams are compared for a system with reliability equal to the left side of the inequality, and a system with reliability equal to the right side of the inequality. \square

A trivial extension of the argument used in Example 3.1 for a two component series system justifies the following remark.

Remark 3.1. *If the components in a series system fail independently, and each component is nondegradable, then the system is nondegradable.*

A general class of systems that contains the two component systems considered in Example 3.1 is the class of *coherent* systems (see Barlow and Proschan [1, 1975], Chapters 1 and 2). These systems are characterized by the conditions:

- (i) If all the components in the system function, then the system functions.
- (ii) If all the components in the system fail, then the system fails.
- (iii) Restoring a failed component will not cause a functioning system to fail.

Systems whose logic models can be represented by conventional block diagrams, or by fault trees using only "and" and "or" gates are coherent.

The *reliability function*

$$(3.3) \quad p = h(p_1, \dots, p_n)$$

of a system (coherent or not) relates the probability p that the system will function to the probabilities p_1, \dots, p_n that its n components will function when the components fail independently. The reliability function of a coherent system satisfies the inequality

$$(3.4) \quad h(p_1 q_1, \dots, p_n q_n) \leq h(p_1, \dots, p_n) h(q_1, \dots, q_n)$$

for all probabilities $p_i, q_i, i = 1, \dots, n$ ([1], Theorem 1.3, page 23). Equality holds when $0 < p_i < 1, 0 < q_i < 1, i = 1, \dots, n$, only if the system is a series system.

A system of independent components is degradable if

$$(3.5) \quad \begin{aligned} \bar{F}(d_1, d_2) &= h(\bar{G}^{(1)}(d_1, d_2), \dots, \bar{G}^{(n)}(d_1, d_2)) \\ &\leq h(\bar{G}_1^{(1)}(d_1), \dots, \bar{G}_1^{(n)}(d_1)) \\ &\quad \cdot h(\bar{G}_2^{(1)}(d_2), \dots, \bar{G}_2^{(n)}(d_2)) \\ &= \bar{F}_1(d_1) \bar{F}_2(d_2) \end{aligned}$$

where \bar{F} denotes a survival function pertaining to the system, and $\bar{G}^{(i)}, i = 1, \dots, n$, denote survival functions pertaining to the components. The system is nondegradable if equality holds in (3.5).

If the components in a system are nondegradable, then

$$(3.6) \quad h\{\bar{G}^{(1)}(d_1, d_2), \dots, \bar{G}^{(n)}(d_1, d_2)\} \\ = h\{\bar{G}_1^{(1)}(d_1) \bar{G}_2^{(1)}(d_2), \dots, \bar{G}_1^{(n)}(d_1) \bar{G}_2^{(n)}(d_2)\}.$$

If the components in a coherent system are degradable, then

$$(3.7) \quad h\{\bar{G}^{(1)}(d_1, d_2), \dots, \bar{G}^{(n)}(d_1, d_2)\} \\ \leq h\{\bar{G}_1^{(1)}(d_1) \bar{G}_2^{(1)}(d_2), \dots, \bar{G}_1^{(n)}(d_1) \bar{G}_2^{(n)}(d_2)\},$$

since the reliability function of a coherent system is increasing in each of its arguments ([1], Theorem 1.2, page 22).

In view of (3.5), augmented by (3.7), the following theorem is a direct consequence of inequality (3.4).

Theorem 3.2. *A coherent system of independent, degradable (including nondegradable) components is degradable.*

The following remark can be established from the condition for equality in inequality (3.4).

Remark 3.3. *If a coherent system of independent, nondegradable components is itself nondegradable, and if amongst the range of its possible service environments there is one environment in which, for some period of exposure, the survival of each component is neither impossible or certain, then the system must be a series system.*

The practical import of Remark 3.3 is that only series systems of nondegradable components can be treated as nondegradable, unless there

are some atypical constraints on the range of service environments embraced by a mission.

Remark 3.3 also serves to emphasize that the notions of a nondegradable or a degradable device are defined by the relationships (3.1) and (3.2) relative to some range of possible service environments E . These definitions are strengthened, in a natural and appropriate way, if the range of service environments to which the device may be exposed is assumed to have the following closure property.

A range E of possible service environments is complete if, whenever e_1, e_2, \dots are environments in E , then the environment e which consists of an exposure of arbitrary duration d_1 to e_1 , followed by an exposure of arbitrary duration d_2 to e_2 , and so on, is also in E .

In essence, E is complete if every phased mission profile that can be constructed from environments present in E is also to be found in E .

If a device is nondegradable with respect to a complete range of service environments E , then for each phased mission profile $e_1, d_1; e_2, d_2; \dots, e_m, d_m$ constructed from environments in E ,

$$(3.8) \quad \bar{F}(d_1, \dots, d_m) = \bar{F}_{1, \dots, m-1}(d_1 + \dots + d_{m-1}) \bar{F}_m(d_m),$$

where $\bar{F}_{1, \dots, m-1}(d_1 + \dots + d_{m-1})$ is notation for the probability that the device will survive an exposure of duration $d_1 + \dots + d_{m-1}$

to the composite environment $e_1, d_1; \dots; e_{m-1}, d_{m-1}$ which is now in E. Iterating the argument leads to

$$(3.9) \quad \bar{F}(d_1, \dots, d_m) = \bar{F}_1(d_1) \bar{F}_2(d_2) \dots \bar{F}_m(d_m) .$$

Similarly, if a device is degradable with respect to a complete range of service environments E, then

$$(3.10) \quad \bar{F}(d_1, \dots, d_m) \leq \bar{F}_1(d_1) \bar{F}_2(d_2) \dots \bar{F}_m(d_m) .$$

Thus the standard method for predicting the reliability of a device over a phased mission profile is precise if the device is non-degradable with respect to the complete range of service environments embraced by the mission, and is optimistic if the device is degradable.

4. System reliability predictions for phased mission profiles.

There is an elaboration of the standard method for predicting the probability of mission success over a phased mission profile $e_1, d_1; e_2, d_2; \dots; e_m, d_m$ which is frequently used for complex systems. This method has two stages:

- (a) For each component $i = 1, \dots, n$ in the system, the probability $\bar{G}^{(i)}(d_1, \dots, d_m)$ of mission success is predicted by the standard method to be $\bar{G}_1^{(i)}(d_1) \dots \bar{G}_m^{(i)}(d_m)$.
- (b) The system probability $\bar{F}(d_1, \dots, d_m)$ of mission success is predicted by combining the component predictions using the system reliability function h ,

i.e. by

$$h\{\bar{G}_1^{(1)}(d_1) \dots \bar{G}_m^{(1)}(d_m), \dots, \bar{G}_1^{(n)}(d_1) \dots \bar{G}_m^{(n)}(d_m)\}.$$

We will call this procedure the *refined standard prediction method*.

Assuming that the components in the system perform independently, the precise relationship which the refined standard prediction method approximates is

$$(4.1) \quad \bar{F}(d_1, \dots, d_m) = h\{\bar{G}^{(1)}(d_1, \dots, d_m), \dots, \bar{G}^{(n)}(d_1, \dots, d_m)\}$$

If the components are independent and are nondegradable with respect to the complete range of service environments embraced by the mission, then the refined standard prediction method is exact. This observation is confirmed by using (3.9), at the component level, in conjunction with (4.1).

However, if the system is coherent, its components are independent, and are degradable with respect to the complete range of service environments embraced by the mission, then the refined standard prediction method is optimistic, i.e. it over-predicts the probability of mission success. This observation is confirmed by using (3.10), at the component level, in conjunction with (4.1) and the fact that h is increasing.

It is interesting to compare the result of predicting the system mission success probability $\bar{F}(d_1, \dots, d_m)$ by direct application of the standard method with the result of using the refined standard method. In the direct approach $\bar{F}(d_1, \dots, d_m)$ is predicted according to (2.3) with

$$(4.2) \quad \bar{F}_j(d_j) = h\{\bar{G}_j^{(1)}(d_j), \dots, \bar{G}_j^{(n)}(d_j)\},$$

$j = 1, \dots, m.$

With $\bar{F}(d_1, \dots, d_m)$ defined by (4.1) and $\bar{F}_j(d_j)$, $i = 1, \dots, m$, defined by (4.2), the inequality

$$(4.3) \quad \bar{F}(d_1, \dots, d_m) \leq h\{\bar{G}_1^{(1)}(d_1) \dots \bar{G}_m^{(1)}(d_m), \dots, \bar{G}_1^{(n)}(d_1) \dots \bar{G}_m^{(n)}(d_m)\} \\ \leq \bar{F}_1(d_1) \cdot \dots \cdot \bar{F}_m(d_m)$$

holds for a coherent system with independent components that are degradable with respect to the complete range of service environments embraced by the mission. As was the case in the arguments supporting Theorem 3.2, the first inequality in (4.3) holds because h is increasing, and the second inequality is a consequence of (3.4).

Thus the refined standard prediction method, while optimistic if applied using degradable components, is less optimistic than the direct application of the standard prediction method to the system itself.

In many cases the degradable components in a coherent system are themselves *modules* (coherent subsystems with nonoverlapping component subsets) of more basic degradable components, and these components may in turn be modules, and so on. Component independence at the most basic level is reflected as modular independence at the higher levels of amalgamation. In this situation it is easy to extend the preceding considerations to show that the refined standard prediction method becomes less optimistic as the modeling depth at which standard component

predictions are introduced is increased. As previously noted, if the modeling depth can be carried to a level at which the components are nondegradable, then the refined standard method becomes exact.

Acknowledgment. The author would like to express his gratitude to the Review Committee, G. R. Burdick, R. W. Butterworth, J. B. Fussell, and K. T. Marshall for a number of helpful comments, and to Rosemarie Stampfel who prepared the mats.

REFERENCES

- [1] R. E. BARLOW and F. PROSCHAN, *Statistical Theory of Reliability and Life Testing*, Holt, Rinehart, and Winston: New York, 1975.
- [2] M. G. BELL, *Multi-phase-mission reliability of maintained standby systems*, Naval Postgraduate School Research Report, NPS55Ey75121, Dec. 1975.
- [3] G. R. BURDICK, J. B. FUSSELL, D. M. RASMUSON, and J. R. WILSON, *Phased mission analysis: A review of new developments and an application*, IEEE TRANS. REL., R-26, #1 (April 1977), pp. 43-49.
- [4] J. D. ESARY and H. ZIEHMS, *Reliability analysis of phased missions, Reliability and Fault Tree Analysis*, SIAM, Philadelphia, 1975, pp. 213-236.
- [5] S. E. PILNICK, *An example of phased mission reliability analysis for a hypothetical naval weapons systems*, Naval Postgraduate School Research Report NPS55-77-28, June 1977.
- [6] J. C. RUBIN, *The reliability of complex networks*, *Proceedings of the Aerospace Reliability and Maintainability Conference*, June 1964, p. 263.
- [7] J. H. SCHMIDT and S. A. WEISBERG, *Computer technique for estimating system reliability*, *Proceedings of the 1966 Annual Symposium on Reliability*, pp. 87-97.

- [8] W. E. VESELY and R. E. NARUM, *PREP and KITT: Computer Codes for the Automatic Evaluation of a Fault Tree*, IN-1349, Idaho Nuclear Corporation, August 1970.
- [9] H. ZIEHMS, *Approximations to the reliability of phased missions*, Naval Postgraduate School Research Report NPS55Ey75091, Sept. 1975.