

AD-A050 281

ADVISORY GROUP FOR AEROSPACE RESEARCH AND DEVELOPMENT--ETC F/G 1/3  
APPLICATIONS OF STRUCTURAL OPTIMIZATION FOR STRENGTH AND AEROEL--ETC(U).  
JAN 78 W LANSING, E LERNER, R F TAYLOR  
AGARD-R-664

NL

UNCLASSIFIED

1 OF 1  
ADA  
050281



END  
DATE  
FILMED  
4 -78  
DDC

**AGARD REPORT No. 664**

**Applications of Structural Optimization  
for Strength and  
Aeroelastic Design Requirements**

**by**

**W.Lansing, E.Lerner and R.E. Taylor**

**DISTRIBUTION STATEMENT A**

Approved for public release;  
Distribution Unlimited

**D D C**  
**RECEIVED**  
FEB 22 1978  
**RESERVED**

5

AGARD-R-664

**NORTH ATLANTIC TREATY ORGANIZATION**  
**ADVISORY GROUP FOR AEROSPACE RESEARCH AND DEVELOPMENT**  
**(ORGANISATION DU TRAITE DE L'ATLANTIQUE NORD)**

**AGARD Report No.664**

**APPLICATIONS OF STRUCTURAL OPTIMIZATION**  
**FOR STRENGTH AND AEROELASTIC DESIGN REQUIREMENTS**

by

**W.Lansing, E.Lerner and R.F.Taylor**

D D C  
RECEIVED  
FEB 22 1978  
A  
97

**DISTRIBUTION STATEMENT A**  
Approved for public release;  
Distribution Unlimited

Paper presented at the 45th Structures and Materials Panel Meeting, Voss, Norway, September 1977.

## THE MISSION OF AGARD

The mission of AGARD is to bring together the leading personalities of the NATO nations in the fields of science and technology relating to aerospace for the following purposes:

- Exchanging of scientific and technical information;
- Continuously stimulating advances in the aerospace sciences relevant to strengthening the common defence posture;
- Improving the co-operation among member nations in aerospace research and development;
- Providing scientific and technical advice and assistance to the North Atlantic Military Committee in the field of aerospace research and development;
- Rendering scientific and technical assistance, as requested, to other NATO bodies and to member nations in connection with research and development problems in the aerospace field;
- Providing assistance to member nations for the purpose of increasing their scientific and technical capabilities;
- Recommending effective ways for the member nations to use their research and development capabilities for the common benefit of the NATO community.

The highest authority within AGARD is the National Delegates Board consisting of officially appointed senior representatives from each member nation. The mission of AGARD is carried out through the Panels which are composed of experts appointed by the National Delegates, the Consultant and Exchange Program and the Aerospace Applications Studies Program. The results of AGARD work are reported to the member nations and the NATO Authorities through the AGARD series of publications of which this is one.

Participation in AGARD activities is by invitation only and is normally limited to citizens of the NATO nations.

The content of this publication has been reproduced directly from material supplied by AGARD or the author.

Published January 1978

Copyright © AGARD 1978  
All Rights Reserved

ISBN 92-835-1269-3



Printed by Technical Editing and Reproduction Ltd  
Harford House, 7-9 Charlotte St, London, W1P 1HD

## PREFACE

The evaluation of the impact of optimization techniques on the design of aerospace structures has been, for years, a very important work of the Structures and Materials Panel, and a Symposium on this subject was held with great success in 1970. The purpose of the pilot paper, that Dr W.Lansing was invited to present to the Sub-Committee on Aeroelasticity, was to review the progress that has been made in this field during the last few years.

The paper concentrates on the use of optimization in the design of structures from the point of view of aeroelasticity, taking into account the constraints due to loads. It gives a survey of the efforts that have been achieved in the main US firms and organizations and shows very clearly that most of the techniques are now at the stage where they are used, or can be used, for actual design.

The Sub-Committee on Aeroelasticity felt that the publication of Dr Lansing's paper would provide the NATO community with excellent information on the state of the art in the field of optimization.

G.COUPRY  
Chairman, Sub-Committee on  
Aeroelasticity

ABSTRACT for		
NTIS	White Section	<input checked="" type="checkbox"/>
DTIC	Self Section	<input type="checkbox"/>
UNANNOUNCED		<input type="checkbox"/>
JUSTIFICATION		
BY		
DISTRIBUTION/AVAILABILITY CODES		
Dist.	AVAIL.	REG./SPECIAL
A		

# APPLICATIONS OF STRUCTURAL OPTIMIZATION FOR STRENGTH AND AEROELASTIC DESIGN REQUIREMENTS

by  
Warner Lansing  
Head, Structural Mechanics Section  
and  
Edwin Lerner  
Technical Specialist, Structural Mechanics Section  
Grumman Aerospace Corporation  
Bethpage, New York 11714 - U.S.A.

and  
Ronald F. Taylor  
Aerospace Engineer, Structural Optimization Group  
United States Air Force Flight Dynamics Laboratory  
Wright-Patterson Air Force Base, Ohio 45433 - U.S.A.

## SUMMARY

The need to design airframe components of minimum weight, while taking into account both strength and aeroelastic requirements, has been recognized for some time. This paper presents an historical review of optimization technology development and a state-of-the-art survey of methods in use by U.S. industry that indicate considerable progress has been made in automating this aspect of the airframe design process. It is concluded that algorithms for addressing strength and flutter are now sufficiently developed for practical use at all levels of design, and for addressing other aeroelastic design objectives in the preliminary design stage. It is recommended that airframe designers utilize these methods more extensively in future aircraft development programs. Additional effort is needed to extend some of the finite-element resizing techniques so that static aeroelastic design objectives can be treated as effectively as flutter-speed requirements, and additional computer software development is always desirable to upgrade analysis and data management capabilities.

## ACKNOWLEDGEMENT

The authors express their gratitude to the following aircraft companies for their valued contributions to this paper: the Boeing Company, General Dynamics Corporation, the Lockheed-California Company, McDonnell Douglas Corporation, and Rockwell International Corporation. We especially want to thank Dr. James J. Olsen of the Air Force Flight Dynamics Laboratory for encouraging the writing of this paper, for his assistance in securing much of the material presented, and for his overall guidance.

## INTRODUCTION

A great deal has been written in recent years about automated methods for analyzing airframe structures for strength and aeroelastic behavior. Most of our major airframe companies have this capability as part of their interdisciplinary design analysis systems. It has also been reported that in many cases these analysis tools are being supplemented with automated resizing procedures for speeding up the design process, and substantial benefits from their use are forecast. Developers of these new optimization techniques anticipate that, while they should have obvious application to the more conventional metallic types of construction, the biggest gains may well be in advanced composite structures where the designer has much broader latitude in meeting strength and stiffness requirements independently of one another.

The central question to be addressed in this survey paper is this: What progress has already taken place in making practical use of this emerging structural optimization technology? Its corollary is: What future work is needed?

To answer these questions, the U. S. Air Force Flight Dynamics Laboratory recently solicited the major U. S. airframe manufacturers for information on their experience in applying structural optimization. The material presented in this paper is based essentially upon their response.

Initially, we shall very briefly review the history of structural optimization technology. Next, we will discuss a number of methods available in the industry, and examine some examples of their application. Conclusions are drawn as to where we stand now, and what our needs are for the future.

## HISTORICAL REVIEW OF STRUCTURAL OPTIMIZATION TECHNOLOGY

In the following technology review, the main contributions are cited to give an historical rather than detailed theoretical perspective. Methods which have been adapted for combined strength and aeroelastic constraints are particularly emphasized. References 1 through 5 give a more complete summary of the literature.

At the end of the 1950's, strength optimization methods consisted primarily of simultaneous failure mode criteria for components, and fully stressed design (FSD) for structural systems. In the FSD approach, the structural members are sized so that each sustains a limiting stress under at least one load condition, or is at its minimum manufacturing gage. In the case of statically determinate structures, a

fully stressed minimum-weight design can be arrived at directly. However, for highly redundant structures common in airframe design, an iterative procedure is necessary to achieve an FSD. In the latter case, it has been demonstrated that such a design is not necessarily optimum from a weight standpoint [6]. Nevertheless, in spite of its theoretical shortcomings, FSD has shown to be a valuable approach to efficient design of structures with a large number of members.

During the early 1960's Schmit (References 7 and 8, for example) and others developed more theoretical approaches to automated structural design based on mathematical programming methods. It was demonstrated that, for small to moderate sized problems, a wide variety of constraints such as stress, deflection, and stability could be handled in a unified manner. As shown in Reference 9, the development of these methods met with mixed success as problem size increased.

By the mid-1960's, it was becoming increasingly clear to a number of investigators that mathematical programming methods were not well suited for the strength design of highly complex structures with multiple loading conditions. In the work of Venkayya, et al. [10] in 1968, an efficient resizing procedure for stress and displacement constraints was introduced. The concept was based on resizing to achieve uniform strain-energy density and incorporated some aspects of variational and numerical search techniques. Reference 11 presents a variety of static and dynamic cases which demonstrate the versatility of the method.

Taig and Kerr [12] demonstrated an optimality criterion approach on several problems where multiple displacement requirements were involved. It was indicated that efforts were under way to extend the techniques to design for increased aeroelastic effectiveness, natural frequency requirements, strength, and generalized stiffness. In all practical problems considered, resizing procedures converged rapidly; however, special problems could be contrived where this was not true.

Historically, the approach to strength and stiffness design of lifting surfaces has been to design first for strength, and then to check for stiffness. Attempts to achieve a compromise between stiffness and weight have been reported as early as 1942 by Turner [13]. At that time, design improvements were achieved exclusively through the use of heuristic procedures rather than by application of fundamental approaches. It is appropriate that Turner's 1968 paper [14] on the same subject provided a great deal of motivation for present interest in this area.

Some of the early stiffness optimization attempts include work by MacDonough [15] who redistributed material to maximize bending and torsional frequencies for fixed structural weight. Head [16] chose to make the strain energy density in the wing torsion mode constant to achieve adequate flutter margins with near-minimum weight.

Recent interest in structural optimization of lifting surfaces for aeroelastic requirements has its basis in work of Turner, Ashley, and McIntosh during the late 1960's. Turner's work [14] represents the first reported results of aeroelastic optimization of a lifting surface by variational methods. Whereas Turner concentrated on discrete structural models, Ashley and McIntosh [17] examined some continuous models, drawing techniques from classical calculus of variations and more modern applied optimal control theory.

From the late 1960's to the present time, numerous research papers and doctoral dissertations were generated by Stanford University researchers in the area of structural optimization with complex constraints such as flutter and dynamic response. The most recent work was accomplished by Segenreich, Johnson and Rizzi [18].

By 1970, static and dynamic structural and loads analysis methods were developed to the point that complex lifting surfaces could be studied and the results compared with experiment. Turner and Bartley [19] performed a flutter design study on a supersonic transport (SST) model and determined that, although analysis methods were vastly improved, response time was still inadequate for design purposes. The thin-wing SST configuration with its slender body, low-aspect-ratio wing, and heavy wing-mounted engines produced low natural frequencies and complex mode shapes. Finite-difference approximations to flutter-velocity derivatives were used to improve flutter margins, but calculations were laborious and time consuming. It was now clear that the need was great in the airframe industry to develop an integrated design system incorporating the latest analysis methods.

A computerized optimization procedure for stabilizers was developed by Triplett and Ising [20] during the same time period as the SST study. A set of simplified design parameters was systematically varied to satisfy constraints of performance control requirements, stability margin, strength, and flutter velocity. The flutter control variables consisted of balance weight, pitch and roll restraint of the support, and torsional stiffness level. This interdisciplinary effort represented a significant first step in developing an automated preliminary design tool for practical application.

One of the first direct attempts at automated flutter and strength optimization was performed by Stroud, Dexter, and Stein [21] by use of the penalty function method. This is a procedure for transforming a constrained mathematical programming problem into an unconstrained one by forming a functional which is the sum of the merit function and weighted reciprocals of the constraints. As developed by Fiacco and McCormick [22], a sequence of unconstrained minimizations then takes place to arrive at an optimal design.

The penalty function approach was also applied by McCullers and Lynch [23] to the design of fiber-composite lifting surfaces modeled as plate-like structures. During the optimization process, the constraints included strength, divergence, and flutter. The design variables were coefficients in assumed polynomial thickness distributions. Mass-balance variables were also included to satisfy the flutter requirement.

Haftka [24] also developed a preliminary design program for strength and flutter requirements which implemented the penalty function approach. A wing structure was idealized by finite elements, and it was shown that the number of design variables can be significantly less than the number of finite elements without incurring large weight penalties. It was also found that the flutter speed may not be a continuous function of structural stiffness. An alternate constraint in terms of damping was suggested.

A major contribution to the automation of flutter resizing was accomplished by Rudisill and Bhatia [25] with their formulation of flutter-velocity derivatives. The derivative expressions were implemented in a combination of numerical search moves which proved effective for a small number of design variables on a high-aspect-ratio wing. A study of the convergence of analytical derivatives with increasing number of vibration modes was performed by Haftka and Yates [26]. The need for continually updating modes during resizing in which derivative-based methods are used was indicated.

O'Connell, Radovcich, and Hassig [27] employed flutter-velocity derivatives in an efficient numerical search procedure. Features of the method included: (1) initial gradient resizing to satisfy the flutter-speed constraint; (2) weight minimization at constant flutter speed; (3) numerical maximization of weight reduction at each step; (4) inclusion of minimum-gage constraints. An example was presented for a 39 degree-of-freedom wing having eight beam-type finite elements.

Siegel [28] implemented an approximate optimality-criterion approach for flutter resizing which was based on the hypothesis that the most efficient structure is one that has constant average strain energy per unit structural volume in the flutter mode. The approach was successfully applied to beam-modeled lifting surfaces to achieve adequate flutter margins by allowing only the addition of structural material. In this way, it was assumed that strength requirements would not be violated.

Another optimality condition for flutter was obtained by Pines and Newman [29] using a Lagrange multiplier approach similar to that which Turner used in 1968. The Pines and Newman approach differed from Turner's in that: (1) quasi-static aerodynamics were used which led to real, rather than complex, variables in the aeroelastic equations; (2) flutter frequency was allowed to vary; and (3) more efficient matrix solution techniques were used.

Kiusalaas [30] reviewed the use of optimality criteria for structural design including flutter optimization with analytical derivatives. Segenreich and McIntosh [31] adapted the recursion formula of Kiusalaas and presented numerical results for frequency, compliance, and flutter-speed constraints. It was concluded by the latter investigations that recent trends support the desirability of mixing optimality criteria and mathematical programming methods.

Analytical flutter-velocity derivatives were the key to the development of a large-scale strength and flutter optimization program reported by Wilkinson, Lerner, and Taylor [32]. Drawing on experience gained from studying methods based on optimality criteria and numerical search techniques, an efficient flutter-resizing algorithm was developed that was founded on the concept of uniform flutter-velocity derivatives for members that are resized to meet a flutter requirement. This algorithm was integrated with an FSD approach for satisfying strength requirements.

## SURVEY OF INDUSTRY METHODS AND APPLICATIONS

Thus far, the application of automated structural analysis and minimum-weight resizing procedures to lifting surfaces that are subject to strength and aeroelastic requirements has generally been limited to design study problems and to problems that were created to demonstrate the capabilities of a particular computer program. Nevertheless, the examples presented are sufficiently realistic to stimulate interest in using the methods in the future design of actual flight hardware.

For convenience of presentation, each of the automated resizing methods cited, and the examples selected to illustrate the use of some of the methods, has been categorized according to the type of structural mathematical model that the method employs. There are basically three such categories; these are based upon

- Beam-type models
- Plate-type models
- Finite-element models

### Beam-Model Approaches

The use of simple beam models to represent the flexural and torsional stiffness of high to moderate aspect-ratio surfaces has been common practice throughout the aircraft industry from its beginnings. Primary use of these models had been for initial structural sizing for strength requirements and for computation of influence coefficients for flutter calculations. In recent years, however, some companies have developed design optimization procedures which utilize beam models in conjunction with automated sizing techniques to meet specified strength and aeroelastic design objectives.

Rockwell International Corporation has developed and applied two computer programs which aim for minimum-weight, flutter-free designs of beam-type idealizations. Both the Structural Optimization Program (STROP) and the Composite Optimization Program (COP) use an approximate optimality criterion which seeks a state of constant mean strain-energy density in the flutter mode [28,32]. The programs can effectively identify the regions of a lifting-surface design where stiffening will have the greatest impact on increasing the flutter speed. The structure may have cantilever or free-free boundary conditions with

root flexibility, and the programs can handle multiple external stores and control surfaces. The optimized structure is determined in a single computer run with minimal computing time. Both STROP and COP are appropriate for preliminary design studies and for intermediate and follow-up design efforts. STROP has been in development since 1968 and was employed on the wing and tail surfaces of an advanced bomber to ensure flutter-free design. More recently, COP was used in the design of the lifting surfaces of the National Aeronautics and Space Administration HiMAT (Highly Maneuverable Aircraft Technology) project. (HiMAT is a remotely piloted research vehicle which is scheduled for first flight in 1978.) The programs are presently being extended to treat beam-type idealizations of an entire aircraft.

STROP is designed to optimize metallic structures, for which the ratio of torsion stiffness (GJ) to bending stiffness (EI) is constant at a given cross-section, by making skin gage changes in the airfoil structural box. COP is designed to optimize airfoils with structures built from advanced composite materials, which have the quality of a wide variance in the GJ to EI ratio at a given cross section, by manipulating ply orientation and thickness. COP adjusts skin gages for bending and torsion stiffnesses separately.

The starting structure for the optimization process is usually the strength design, which may include minimum gages. The airfoil structure is represented by beam elements, whose stiffness properties are defined in terms of EI for bending and GJ for torsion, and elastic axis, and structural box geometry. The airfoil is divided into strips with respect to the elastic axis for the mass properties. Theodorsen-type strip theory aerodynamics are accounted for by using  $dC_L/d\alpha$  values per local strip for the appropriate planform.

A vibration analysis is performed for a preselected number of modes, which are passed on to the flutter analysis. The flutter analysis, using the V-g approach, determines the mode that goes unstable at the lowest speed. If this speed is above the required speed, an exit is provided in the program. If the flutter speed is below the required speed, a measure of the strain energy densities in the flutter mode is calculated for each beam. Those beams containing the largest energy densities are stiffened by increasing their skin gages. The associated stiffness and mass properties of the stiffened beams are then incorporated into the structural data. Vibration and flutter analyses are repeated and the structure resized until the required flutter speed is reached.

As an application of one of the programs, COP was employed to increase the flutter speed of a vertical tail preliminary design for a high-performance fighter aircraft. The surface was made of advanced composite material and had a constant-sweep elastic axis. FIGURE 1 shows schematically the structural box breakdown into eleven beam elements along the elastic axis. A typical mass strip is indicated, along with the centers of gravity for all strips; a typical aerodynamic strip is also shown.

Seven vibration modes for the 33 degrees of freedom (one deflection and two angles for each beam) were calculated for each cycle of iteration in the flutter resizing process. The calculated flutter speed for the strength design was 73% of the required speed. COP proceeded to modify the structure to raise the flutter speed in four iterations. FIGURE 2 shows the increased weight requirements for each iteration in terms of percent of total surface weight for percent increase in flutter speed. At the fourth iteration, the flutter speed exceeded the required value by only about 2%. This last design required a 10.4% increase in weight to achieve a 40.5% increase in flutter speed; backing off to the required speed would save an insignificant 0.8% of the total weight.

FIGURE 3 shows the required EI and GJ stiffness distribution obtained with COP. The dashed curve indicates the strength design torsional stiffness for comparison with the required flutter-free design. No increase in bending stiffness was required.

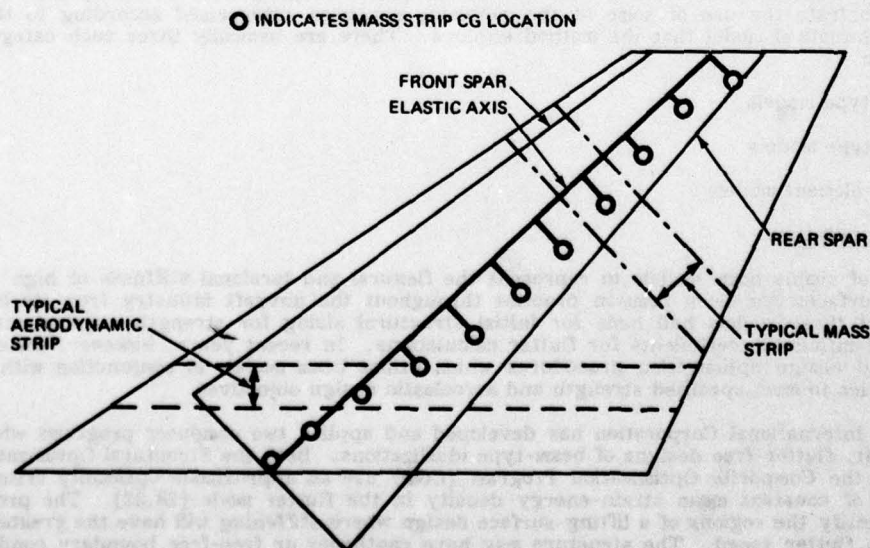

1921-1

FIGURE 1. Vertical Tail of High-Performance Fighter

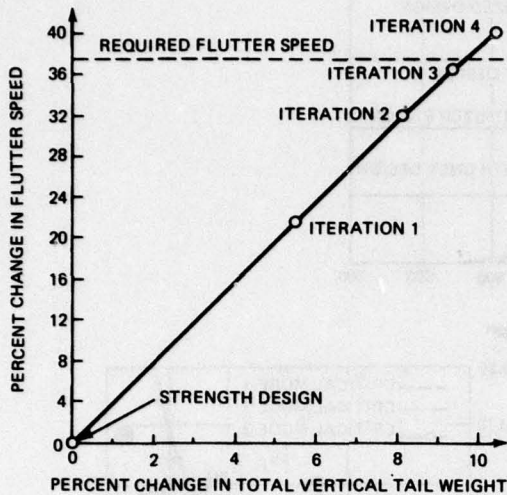

1921-2  
FIGURE 2. Vertical Tail Flutter Resizing by COP

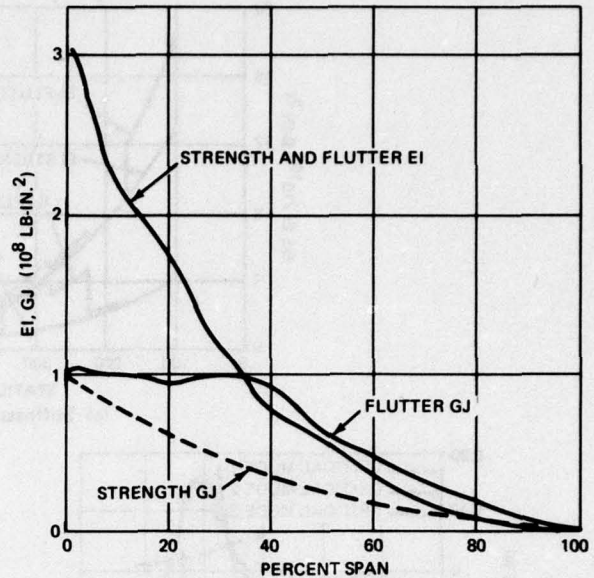

1921-3  
FIGURE 3. Vertical Tail Stiffness Distribution

At the Douglas Aircraft Company of McDonnell Douglas Corporation, automated optimization has been used for several years to meet simultaneous strength and flutter criteria for configurations in which beam-type idealizations are adequate. In contrast with the previously described method which was based on an optimality criterion approach, the Douglas optimization module (identified as "C4EC") employs mathematical programming techniques and has the capability of seeking a minimum-weight design for a surface subject to as many as five critical flutter modes simultaneously. These critical flutter modes may consist of modes from different configurations, several critical or near-critical modes from the same configuration, or any combination thereof. The program is written with the assumption that the initial design has been optimized for strength before flutter analysis. If there exists at least one flutter mode below a required speed, then the necessary modifications are made, on a least-weight basis, without violating any lower or upper bounds on design variables which were established by the initial strength design and reasonable design practice.

This optimization program operates in two redesign modes. The first is a feasible-design mode, wherein the necessary design changes are made to drive all critical flutter modes toward the required flutter speed simultaneously. At the conclusion of a feasible design step, a least-weight mode is entered; here, the flutter speed of all critical modes is held constant and the weight is minimized. Step size within each mode is constrained such that no design variable violates its lower or upper bound. The entire process is essentially a constrained, steepest-descent procedure.

An interesting application of the C4EC optimization module was made on a conceptual composite wing design for a medium size transport. FIGURE 4 summarizes some of the results. Note that for the base case, corresponding to a strength design, there are three flutter modes that are unstable below the required velocity. After selective stiffening, through a combination of increases in both EI and GJ, a combined strength-adequate, flutter-free design is achieved. The automated procedure employed here was able to find the minimum-weight solution routinely in far less engineering and computer time than would have been the case using traditional engineering judgement methods, if indeed the traditional approach would be capable of finding the minimum-weight solution.

Quite different from either of the preceding optimization methods is the automated preliminary design approach embodied in the Composite Box Optimization Program (COMBO), developed by the Grumman Aerospace Corporation [33]. COMBO is not an optimization program in the sense that it achieves a minimum-weight design for strength and flutter. Instead, the major feature of the program lies in its ability to rapidly design composite layups that satisfy user-specified strength, torsional stiffness, and bending/twisting coupling requirements. The program employs simple beam theory which has been extended to include the coupling between bending and twisting that can be achieved with composite materials. COMBO is useful for performing rapid trade studies in the early stages of an aircraft development project. Input includes a spanwise torsional stiffness (GJ) distribution, structural applied loads, composite fiber directions, basic wing geometry, and the desired streamwise twist distribution at each station along the span for two loading conditions. Its output consists of weight and cost information and influence coefficient matrices required as input to conventional flutter and aeroelastic load prediction programs.

Another preliminary design tool is the ORACLE system developed by the Boeing Company. It evolved from a need to predict loads and structural material distributions in lifting surfaces which are affected significantly by aeroelasticity. The system provides automated sizing to arrive at a fully stressed design for aeroelastically corrected applied loads. An option is available to compute the required jig twist distribution and perform additional resizing in cases where a desired cruise span loading is specified.

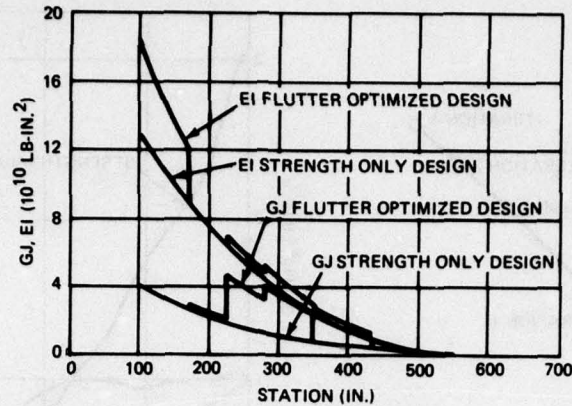

(a) Stiffness Distribution

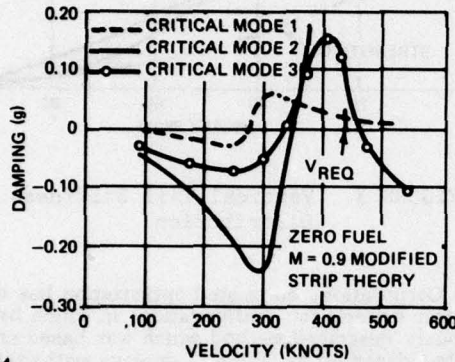

1922-4

(b) Base Case - Strength Constraints

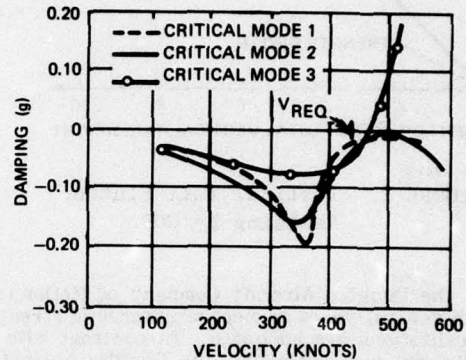

(c) Optimized Case - Strength Plus Flutter Constraints

FIGURE 4. Application of "C4EC" to a Transport Composite Wing

Although the beam-model approach is the simplest and fastest way to pursue design optimization, and is particularly useful in the conceptual or preliminary design stages, beam models do suffer from shortcomings that can be important when it comes to detail design. Some of the more serious limitations imposed by beam-model idealizations are their inability to treat chordwise variations in material distribution; they cannot account for chordwise bending (or cambering); they ignore local root behavior, which can be particularly important in swept surfaces; and they cannot properly account for structural design features and behavior associated with loads introduced by leading- or trailing-edge control surfaces or overhangs. The methods described in the following two categories are better able to cope with some of the problems that beam models cannot handle.

#### Plate-Model Approaches

In contrast with a beam model, the use of a plate-type representation of the primary structure of a lifting surface allows the treatment of both spanwise and chordwise variations in cover material distribution. The best known procedure that utilizes this type of idealization is a comprehensive, automated design analysis and optimization system developed by General Dynamics Corporation for the U.S. Air Force. It is known as the TSO Program (Aeroelastic Tailoring and Structural Optimization Procedure or Wing Aeroelastic Synthesis Procedure) and is intended for primary use in preliminary design [34,35].

The development of TSO was motivated by the growing use of advanced composites and the desire to achieve the most effective use of these materials. To do this, as pointed out by General Dynamics, "... it is necessary to develop a total design coupling the advantages of composite materials with aerodynamic planform and airfoil requirements to achieve the maximum benefit from both technologies. The directional properties of the material permit the wing or tail to be tailored to yield improved dynamics, deflection, ... and aeroelastic characteristics." TSO is intended to address this "total design" problem by combining aerodynamic, static aeroelastic, flutter, and structural calculations, at a level of detail consistent with the program's role as a preliminary-design tool.

TSO is designed to yield optimum wing laminates that satisfy a variety of design constraints. The procedure considers only the wing skin thickness distribution (and orientations for composites) and balance masses as design variables. It is assumed that the external lines of the wing have been defined during configuration synthesis and that the substructure will be designed after the skins are defined. The stiffness and mass matrices for the wing structural box, the leading edge, and the trailing edge are generated using a direct Rayleigh-Ritz energy formulation, which provides the necessary analysis speed. The leading and trailing edge models are coupled to the structural box with moment springs. The optimization scheme uses the Fiacco-McCormick (penalty function) nonlinear programming technique [22]. During the design process, the active parameters include flutter speed, divergence speed, aircraft angle of attack (which includes wing flexibility effects and required tail trim for a specified load factor),

strains, flexible lift, flexible-to-rigid lift ratio, roll effectiveness, fundamental frequency, and structural weight. These parameters can be included either as measures of merit to be adjusted, as constraints, or as both.

A conceptual fighter wing simulation based on TSO is shown in FIGURE 5. It consists of three plates with free boundary conditions, coupled together by point rotational springs representing actuators. Each plate is defined as a trapezoid, with its overall depth expressed in polynomial form as a function of nondimensional trapezoidal coordinates  $\xi$  and  $\eta$ . For composite cover skins, the plate covers consist of up to three layers, where each layer represents a ply grouping with a specific fiber orientation. The thickness of each layer is also expressed in polynomial form, where, for the primary box structure, the polynomial coefficients ( $a_1 \dots a_9$  in FIGURE 5) are design variables. With provision for three fiber orientation angles, nine thickness coefficients for each fiber direction, and ten mass-balance variables, TSO is thus able to deal with up to forty design variables. It may be noted that for a metal design, one thickness polynomial provides a complete description of the skin material distribution.

The elastic deflections of the wing box and leading and trailing edges are each expressed in terms of a series made up of products of chordwise and spanwise deformation shapes represented by Legendre polynomials. The coefficients of the series are the generalized coordinates of the structure, and stiffness and mass matrices are generated in terms of these coordinates. All subsequent computations for strength, flutter, and static aeroelasticity are transformed into this generalized coordinate system. No interpolation is required for any system state evaluations. This development is the key to the significant speed advantage of TSO over conventional finite-element discretization/interpolation methods.

As mentioned earlier, TSO was developed to address the total-design optimization problem in its early stages. The efficiency of the Rayleigh-Ritz based analysis package makes this task feasible. The automated design proceeds in the following manner:

I. The preassigned parameters are

- External lines of the aircraft
- Definition of the structural box and control surfaces
- Nonoptimum weight data
- Load data
- Constraint requirements

II. The design variables are

- Skin thickness distribution coefficients
- Layer orientations
- Balance masses

III. The constraints are

- Minimum and maximum thickness
- Strength
- Flutter speed
- Divergence speed

IV. The objective function may be a combination of

- Weight
- Lift-curve slope
- Flexible-to-rigid load ratio
- Control-surface effectiveness
- Fundamental natural frequency
- Flutter speed
- Deflections.

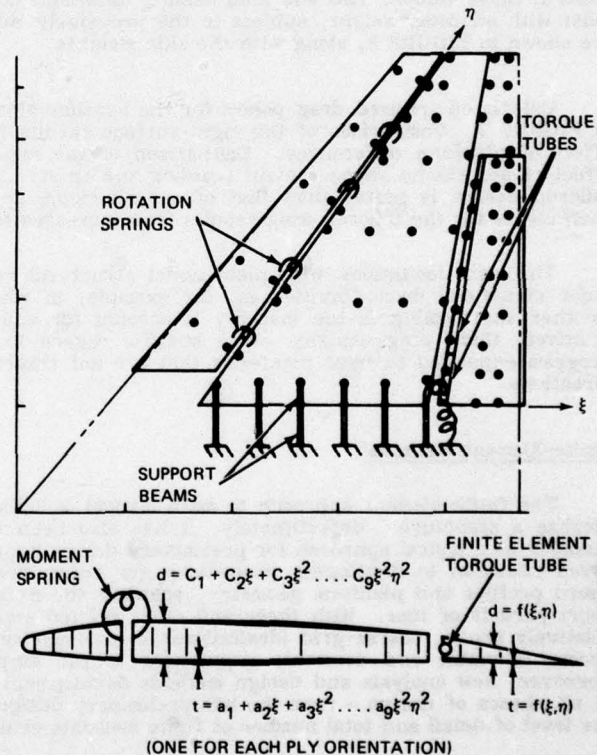

FIGURE 5. Wing Geometry for TSO Procedure

In most aircraft optimization programs, the objective is to minimize weight, and this is the basic function of the TSO procedure. However, by assembling the objective function as a linear combination of the items listed above, other parameters can be optimized instead of, or in combination with, the weight. Alternatively, any of these listed items may be selected as constraints.

In one application of TSO, a study was performed by General Dynamics to design an aeroelastically tailored fighter wing that would provide transonic maneuver performance superior to a state-of-the-art aluminum design [35]. To accomplish this, structural and aerodynamic simulations were developed for a baseline configuration for which wind-tunnel data were available. The structural model is shown in FIGURE 5; the aerodynamic panel representation is illustrated in FIGURE 6. Calculated and test drag characteristics were compared to establish that the simulation was reasonable.

The aeroelastic design was developed by

- Modifying the baseline planform (increased wing area and aspect ratio) to take advantage of the weight savings afforded by composites
- Determining skin designs that would produce desired aeroelastic twist and camber control.

The modified planform and a comparison of its characteristics with the baseline wing are shown in FIGURE 7. This revised planform was used in subsequent work to design the tailored cover skins. In using the TSO procedures to accomplish the latter task, the objective was to have negative twist and positive camber at maneuver load, while satisfying weight, flutter, strength, and flaperon roll effectiveness constraints. The twist was defined as the difference between the displacements normal to the planform of the front and rear spars at span station  $\eta = 0.875$ .

Prior to formal use of the TSO sizing procedure, side studies were performed to evaluate the over-all effects of fiber orientation (in graphite-epoxy) on basic aeroelastic parameters. The orientation of the primary bending laminae was chosen as  $\theta_1 = 0^\circ$  (normal to the airplane longitudinal axis) to simplify manufacturing. With this assumption, the choice of  $\theta_2 = +55^\circ$  resulted in maximizing roll effectiveness, flutter speed, negative twist, and camber with little impact on lift effectiveness. Once the choices  $\theta_1 = 0^\circ$  and  $\theta_2 = +55^\circ$  were made, the selection of  $\theta_3 = -35^\circ$  resulted in maximizing roll effectiveness, negative twist, and camber while having minimal effect on lift effectiveness and flutter speed. With the fiber angles fixed at these values, TSO was then used to determine cover thickness distributions that maximize negative twist with minimum weight, subject to the previously mentioned constraints. The resulting distributions are shown in FIGURE 8, along with the skin weights.

Calculated trimmed drag polars for the baseline aluminum and tailored composite designs are compared in FIGURE 9. Comparison of the rigid-surface results for the two designs provides an indication of the effect of planform differences. Comparison of the rigid results with the aeroelastic results shows the effect of aeroelastic shape control (camber and twist). It is apparent that the aeroelastic response of the tailored design is better than that of the aluminum design. The slight increase in drag at low lift coefficients for the tailored wing results from increased friction, pressure, and trim drags.

The main limitations with plate-model structural representations are their inability to account for major structural discontinuities as, for example, in wheel-well and engine-nacelle regions of a wing. Another shortcoming is the inability to account for substructure flexibility, which may be important in relatively thick wing designs. With specific regard to the TSO Program, one might wish to see the program expanded to treat planforms that are not trapezoidal and to deal with more than just three fiber directions.

#### Finite-Element Methods

The finite-element approach to mathematical modeling is by far the most accurate, practical way to idealize a structure. Unfortunately, it has also been the most time-consuming and has met with some disfavor as a logical approach for preliminary design application. Recently, however, some companies have given attention to developing procedures for automatically generating finite-element models from basic chord profiles and planform geometry, enabling the model-definition process to be completed in relatively short periods of time. With these and other related expediting procedures, and a willingness to accept relatively crude, coarse-grid idealizations in preliminary design studies, the finite-element approach can become a viable and desirable supplement to the simpler beam-model and plate-model approaches. Moreover, new analysis and design methods development can proceed along common lines to meet the needs of all phases of design - from the late preliminary design phase through the final design phase - with only the level of detail and total number of finite elements changing.

Throughout the industry, there appears to be one common aspect to the finite-element design approach for meeting strength and aeroelastic design requirements: namely, all companies size their structures first for strength, generally with the fully stressed design (FSD) approach, and then concentrate on flutter-speed and other aeroelastic design requirements. Resizing by adding material to satisfy an aeroelastic requirement may, in turn, be followed by revised strength resizing, and so on. This involves an iterative scheme aimed at arriving at a combined design satisfying both strength and stiffness requirements with near-minimum weight. Alternatively, as an expediency, some procedures just add material to the most effective elements that can contribute to meeting the stiffness requirements, and stop at that point.

The Lockheed-California Company's approach to automated aircraft structural design is based on the use of an integrated structural analysis system and specific programs within this system for automated structural sizing to meet strength and aeroelastic design requirements. The flexibility of the system permits its application to both production design projects and preliminary design studies. In addition, it permits the amount of interaction among the various analyses to be adjusted to meet the needs of the

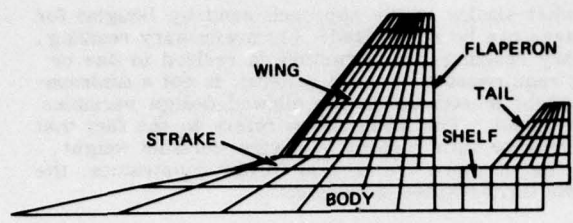

1922-6

FIGURE 6. Aerodynamic Simulation of Fighter

PARAMETER	CHANGE FROM BASELINE (%)
ASPECT RATIO	+12.5
WING AREA	+12.5
TAPER RATIO	0
SWEEP	- 8.25
SEMI-SPAN	+12.5
t/c	-12.5

1922-7

FIGURE 7. Comparison of Tailored Wing Configuration to Baseline

NOTE: ALL DIMENSIONS ARE IN INCHES

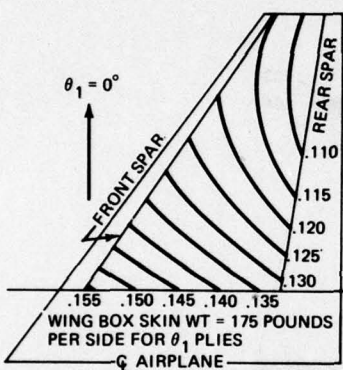

(a) Distribution for  $\theta = 0^\circ$  Plies

1922-8

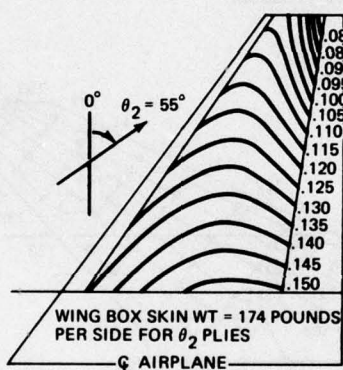

(b) Distribution for  $\theta = 55^\circ$  Plies

1922-9

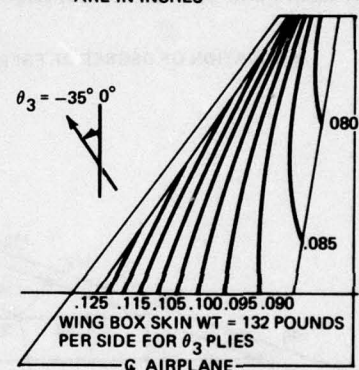

(c) Distribution for  $\theta = -35^\circ$  Plies

1922-10

FIGURE 8. Thickness Distribution for Tailored Wing

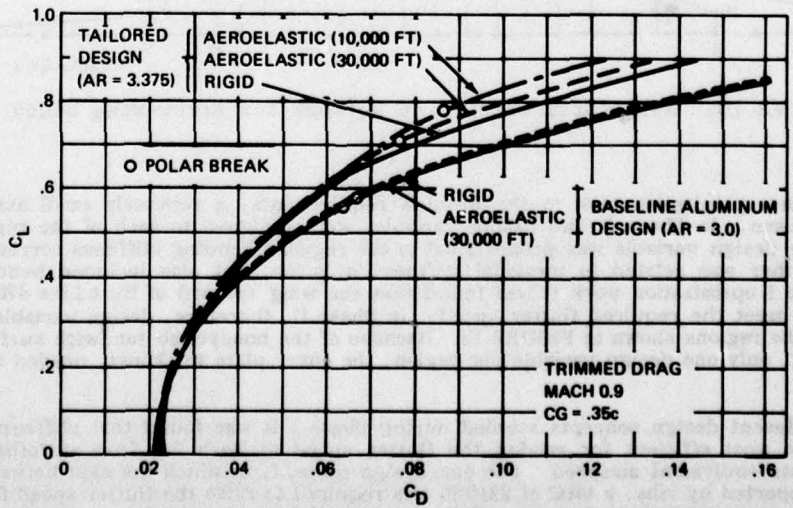

1922-11

FIGURE 9. Comparison of Trimmed Drag at Mach 0.9 for Tailored and Baseline Designs

specific design problem. Lockheed uses a modified version of the NASTRAN System as its primary finite-element analysis tool. It has developed and included in its version of NASTRAN an automated FSD sizing capability that provides starting data for aeroelastic loads and flutter analysis and for flutter optimization [36].

Lockheed's approach to flutter optimization is somewhat similar to the approach used by Douglas for beam-model idealizations discussed earlier. Two major steps can be recognized: (1) preliminary resizing, followed by (2) mass minimization. During the preliminary resizing, the structure is resized in one or more steps, so that the resulting design meets all flutter requirements, but, in general, is not a minimum-weight design. The resizing technique employed adds weight increments to the allowed design variables according to a weighted, modified gradient of the flutter speed. The modification refers to the fact that the design variables having small derivatives of flutter velocity with respect to design variable weight,  $\partial V_f / \partial m_i$ , are ignored. The weighting refers to the fact that if there are several flutter constraints, the derivatives are weighted according to the magnitudes of the flutter-speed deficiencies.

For mass minimization after all flutter constraints are satisfied, an iterative method applicable to one active flutter-speed constraint has been established. Methods for mass minimization, applicable when there are multiple active flutter constraints, are in an exploratory development stage. This overall flutter resizing approach is discussed in References 27 and 37. It is presently a part of Lockheed's Graphics Flutter Analysis Methods (GFAM) System. Because the system is limited to 80 design variables, it is necessary to "zone" portions of the finite-element model, as illustrated in the following example.

Lockheed's flutter optimization capability was used during a structural design study of an arrow-wing supersonic cruise vehicle, which employed a fairly detailed finite-element model [38]. The detail represented in the model is characterized by the gridpoint network shown in FIGURE 10. This network was used for two phases of the structural design. In Phase I, a structure symmetric about an undeformed mean surface plane was assumed, resulting in 1300 finite elements and 1050 structural degrees of freedom. In Phase II, upper and lower surfaces of the structure were allowed to be different, resulting in 2450 finite elements and 2200 structural degrees of freedom.

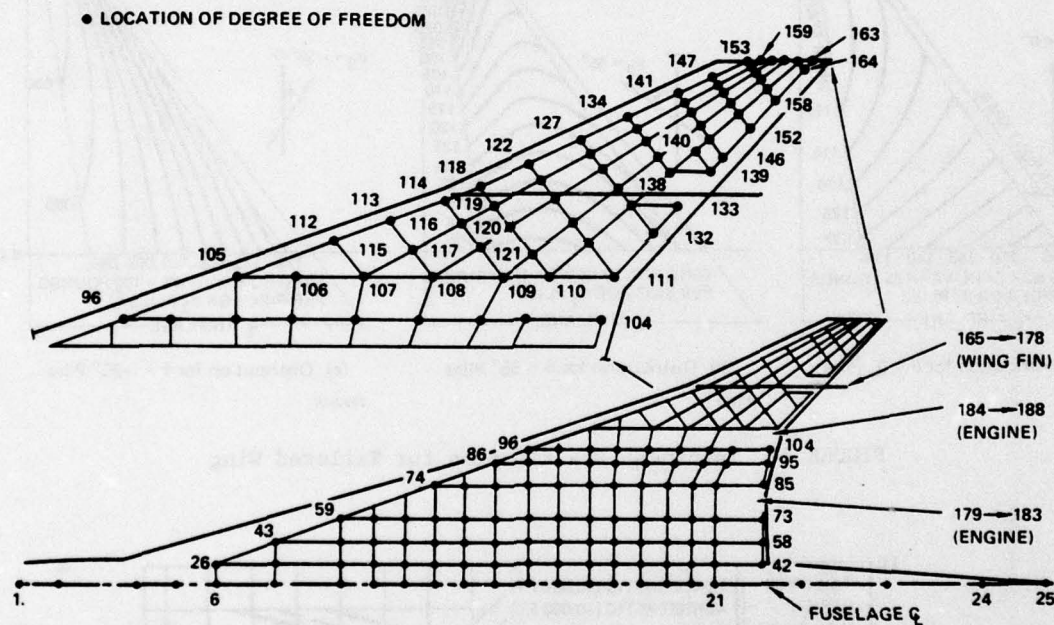

FIGURE 10. Structural Grid Point Network for Arrow-Wing Study

To adjust the optimization task to the problem requirements, a relatively small number of design variables was chosen. In Phase I, two design variables were assigned to each of the regions shown in FIGURE 11. One design variable was proportional to the region's bending stiffness corresponding to wing bending. The other was related to torsional stiffness in pitch, but also included bending stiffness. During the Phase I optimization work it was found that the wing inboard of Butt Line 470 did not require any stiffening to meet the required flutter speed. In Phase II, therefore, design variables were assigned only to each of the regions shown in FIGURE 12. Because of the honeycomb sandwich surface panel design of the outer wing, only one design variable per region, the cover plate thickness, needed to be defined.

For two different design concepts studied during Phase I it was found that stiffening in Region 8 (FIGURE 11) was most efficient for raising the flutter speed at Mach 0.9 from an initial value to the required 468 knots equivalent airspeed. For one design concept, in which the skin between the front and rear spars is supported by ribs, a total of 2210 lb was required to raise the flutter speed from 379 knots to 468 knots. For a monocoque-type design, 1240 lb was required to raise the flutter speed from 423 knots to 468 knots. Later studies indicated that the resulting configurations would still be deficient in flutter speed at Mach 1.85.

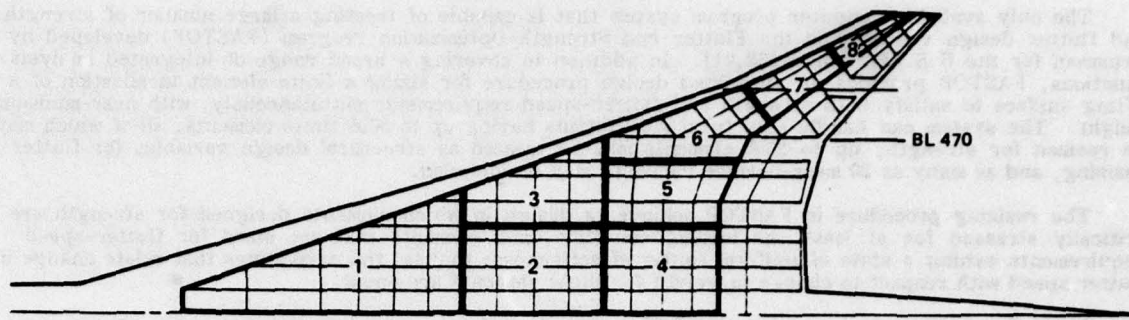

FIGURE 11. Design Regions for Flutter Optimization, Arrow Wing, Phase I

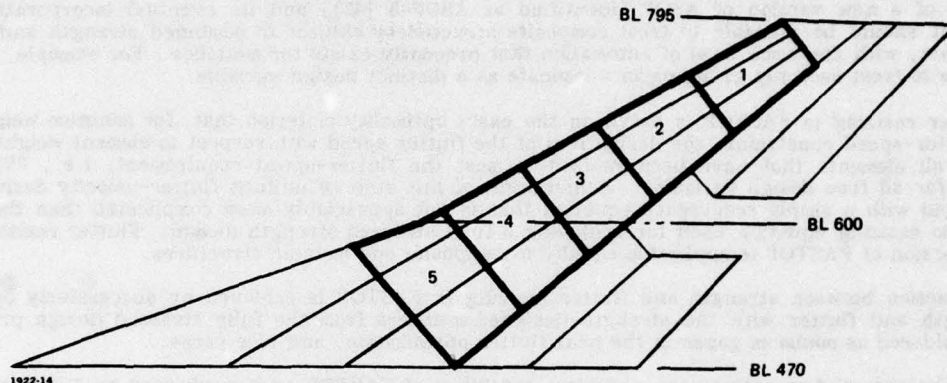

FIGURE 12. Design Regions for Flutter Optimization, Arrow Wing, Phase II

For Phase II, a strength design wing had a flutter speed of 310 knots at Mach 0.9. Raising this speed to 468 knots required a total of 2402 lb. This number includes a small extra speed margin and the effect of some ease-of-manufacturing constraints. The resulting configuration proved to be deficient in flutter speed at Mach 1.85 (563 knots versus 630 knots required). An additional weight of 1198 lb was required to remove this deficiency. Thus, the total flutter penalty incurred was 3600 lb. This represented 4% of the total wing weight.

Lockheed is pursuing some new development work which is indicative of problems associated with the finite-element approach in general. One problem arises because of practical limitations in the ability to model actual hardware construction types and to properly account for realistic failure modes, such as buckling of hat-stiffened cover-skin panels. Another problem results from unrealistic discontinuities in material distribution which can occur from automated sizing. Future developments at Lockheed that are aimed at remedying these problems include provision for selecting improved (preoptimized) allowables which vary as functions of load intensity or other variables and provision for design-parameter combination. This latter feature will permit explicit consideration of practical manufacturing constraints in the sizing process, e.g., realistic variations in wing surface panel thicknesses.

Similar attempts to make fully stressed designs more nearly approach practical strength-critical hardware are under way at other companies as well.

The importance of using detailed finite-element idealizations of large flexible structures in which aeroelasticity is a major design consideration, even in a preliminary design study, is evidenced also in work done by the Boeing Company in its parallel study of an arrow-wing supersonic cruise aircraft [39]. Here, an advanced computerized structural analysis system known as ATLAS [40] was used. This system was initially developed by Boeing and is currently being extended under a cooperative effort with the NASA Langley Research Center.

Boeing's finite-element model contained approximately 2000 nodes, 4200 elements, and 8500 degrees of freedom. To ensure that airloads and stresses would not be determined for a structure having large flutter deficiencies, the wing-tip structure and engine support beams were stiffened, based on results of preliminary flutter calculations. The elastic properties of the initial stiffened model were then used for the determination of static aeroelastic loads, which were, in turn, used to obtain a fully stressed design. This strength-sized structure was used as the starting point for the final flutter analysis and redesign segment of the effort, with the element sizes of the strength design being treated as minimums. To meet the flutter requirements, iterative methods, based largely on engineering judgement were employed.

It was determined that large weight increments are required for flutter, with the same wing outer-panel region as determined in Lockheed's study being the most critical. Reference 39 points out that significant weight savings could be achieved by using formal optimization techniques, which could not be implemented within the scope of the study. It states that resizing based on engineering judgement may be acceptable for a design study, but for actual aircraft design, the use of automated flutter-resizing is highly desirable.

The only available computer program system that is capable of treating a large number of strength and flutter design variables is the Flutter and Strength Optimization Program (FASTOP) developed by Grumman for the U.S. Air Force [32,41]. In addition to covering a broad range of integrated analysis functions, FASTOP provides an automated design procedure for sizing a finite-element idealization of a lifting surface to satisfy both strength and flutter-speed requirements simultaneously, with near-minimum weight. The system can handle structural idealizations having up to 3000 finite elements, all of which may be resized for strength; up to 2000 elements may be treated as structural design variables for flutter resizing, and as many as 20 mass-balance variables may be included.

The resizing procedure in FASTOP achieves a design in which elements designed for strength are critically stressed for at least one loading condition, and elements that are sized for flutter-speed requirements exhibit a state of uniform flutter effectiveness; that is, the derivatives that relate change in flutter speed with respect to change in weight for these elements are equal.

Strength resizing is based on the FSD approach and uses an early version of the Automated Structural Optimization Program (ASOP) [42] to perform the structural analysis and resizing steps. Unfortunately, the version of ASOP that is presently included in FASTOP restricts use of the latter program to metallic structures, insofar as strength resizing is concerned. However, with the recent completion of a new version of ASOP (identified as ASOP-3 [43]) and its eventual incorporation into FASTOP, it should be possible to treat composite structures, subject to combined strength and flutter requirements, with the same level of automation that presently exists for metallics. For example, it should be possible to treat each ply grouping in a laminate as a distinct design variable.

Flutter resizing in FASTOP is based on the exact optimality criterion that, for minimum weight and a single flutter-speed constraint, the derivatives of the flutter speed with respect to element weight must be equal for all elements that have been resized to meet the flutter-speed requirement, i.e.,  $\partial V_f / \partial m_i = \text{constant}$ , for all free design variables. Achievement of this state of uniform flutter-velocity derivatives is accomplished with a simple recurrence equation that is not appreciably more complicated than the familiar stress-ratio resizing equation used for achieving a fully stressed strength design. Flutter resizing in the present version of FASTOP is applicable equally to composite and metallic structures.

Interaction between strength and flutter resizing in FASTOP is achieved by successively optimizing for strength and flutter with the strength-designed members from the fully stressed design procedure being considered as minimum gages in the next flutter optimization, and vice versa.

Calculations to demonstrate the redesign capability of FASTOP were performed by Grumman using detailed finite-element models of two metallic lifting-surface structures: namely, an all-movable horizontal stabilizer and a wing with a pylon-mounted store. A third study was conducted using a simpler preliminary-design representation of a wing with advanced-composite cover skins and aluminum substructure. The characteristics of these models and the results obtained from the application of the program are described below.

For the first two demonstration cases, FASTOP was initially used to (a) compute aerodynamic design loads for specified flight conditions, (b) distribute the design loads to the structures model, and (c) resize the initial gages of the structures model to obtain a fully stressed design. The program was subsequently used to perform interactive strength and flutter resizing beyond the initial strength-based design so as to achieve a significant flutter-speed increase. For the composite wing, the program was used to resize the individual ply thicknesses of a strength-based design for increased flutter speed, considering the gages of the initial fully stressed structure as minimum allowable gages, i.e., noninteractive resizing.

The structures model of the all-movable stabilizer, illustrated in FIGURE 13, was modeled with 890 finite elements. The stabilizer construction consisted of titanium covers, modeled as membrane elements, and a full-depth aluminum honeycomb core, modeled as spanwise and chordwise shear panels having

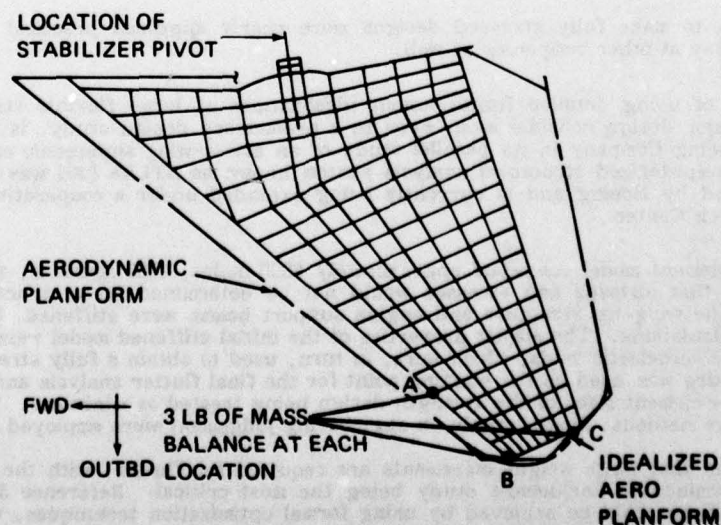

1922-15

FIGURE 13. All-Movable Stabilizer Structure Model

equivalent stiffness properties. Since these equivalent shear panels could not be logically resized for strength or flutter requirements, they were not included in the redesign process, thereby leaving 324 structural design variables.

A supersonic flutter-critical flight condition was selected for flutter redesign, with the goal being to increase the flutter speed of the strength-based design by 25%. Two separate studies were performed, one using both structural and mass-balance design variables and the other using only mass-balance design variables. In the former case, 3 lb of initial mass balance was arbitrarily added at each of the three selected locations illustrated in FIGURE 13.

The results of the redesign study which included both structural and mass-balance variables showed that the mass balance at point B was increased beyond its initial value, whereas the masses at points A and C were progressively reduced. After the third flutter redesign cycle, it was obvious that the mass balance at points A and C would vanish in the final design. Accordingly, this mass balance was eliminated at that stage of redesign, thereby accelerating convergence to the optimum design.

FIGURE 14 shows that a near-optimum design with combined structural and mass-balance variables was achieved after only five redesign cycles. The net weight increase to achieve a 25% increase in flutter speed was 10.70 lb, or 2.6% of the total stabilizer weight. Three additional redesign cycles beyond this point eliminated an additional 0.45 lb - a relatively insignificant amount. The distribution of mass balance and structural weight in the final design, presented in FIGURE 15, indicates that structural stiffening occurred only in the vicinity of the root rib. As a result of load redistribution due to this stiffening, a slight amount of weight (0.24 lb) could be removed from other portions of the surface.

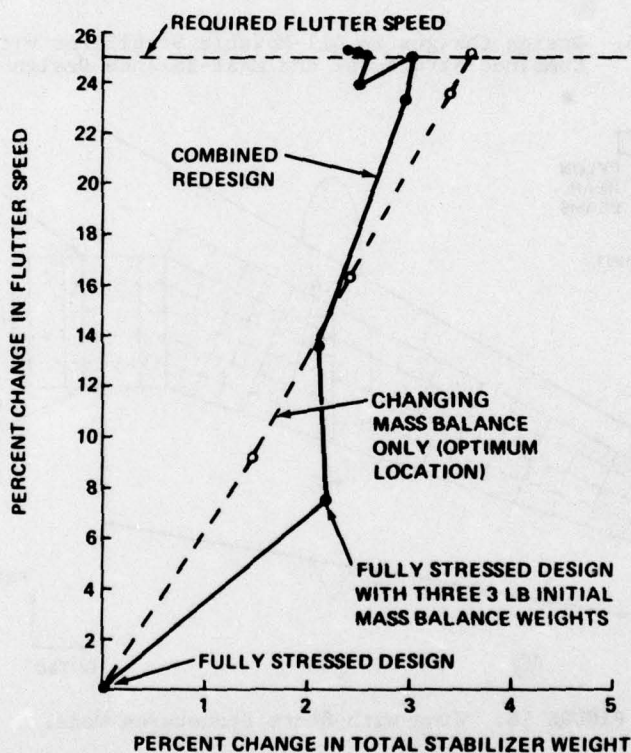

1922-16

FIGURE 14. All-Movable Stabilizer Redesign by FASTOP

In the second study of the all-movable stabilizer, several analyses were performed (see FIGURE 14) using mass balance alone at the most effective location indicated previously by FASTOP (i.e., point B in FIGURE 13). It was determined that 14.70 lb of mass balance would be required to achieve the 25% flutter-speed increase, compared with 10.25 lb of total mass balance and structural weight for the fully iterated combined design. As a matter of further interest, when it was attempted to use FASTOP with structural design variables alone, it became evident that the procedure wanted to add material to elements in the tip region, because of their mass-balance contribution rather than their effect on structural stiffness! This attempt by the program to duplicate the combined design noted previously was slow in converging and was terminated before convergence was achieved.

In a second application of FASTOP, a wing with a pylon-mounted store was investigated. The structural model, illustrated in FIGURE 16, contained approximately 600 finite elements. The idealization of the multi-spar aluminum wing box used quadrilateral membrane elements to represent the covers and shear panels for rib and spar webs. The wing-store pylon was modeled with beam elements attached to upper- and lower-cover wing node points. The weight of the initial fully stressed wing structure was 1340 lb, based on the finite-element idealization, and 1921 lb, including nonoptimum factors and overhanging structure. The store weighed 4500 lb, with a pitch inertia of  $8 \times 10^6$  lb-in<sup>2</sup> about its center of gravity.

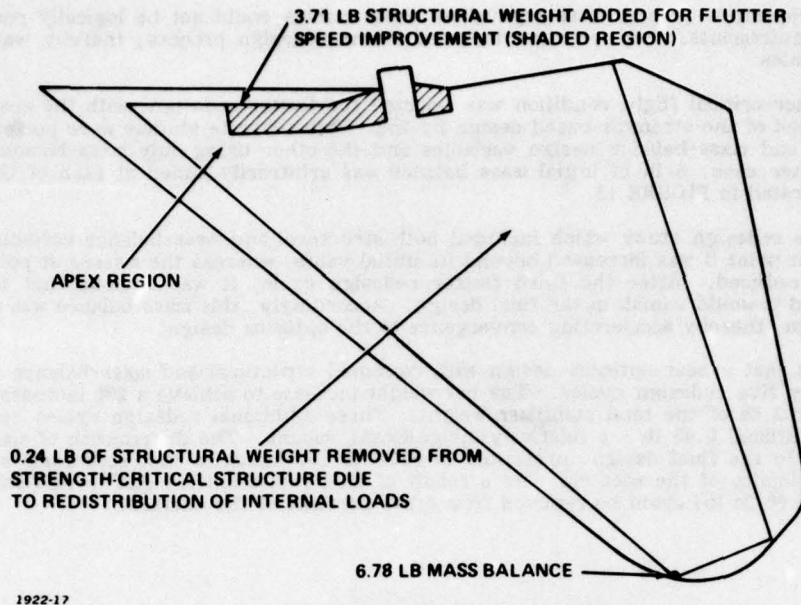

1922-17

FIGURE 15. Design Changes in All-Movable Stabilizer with Combined Structural and Mass-Balance Design Variables

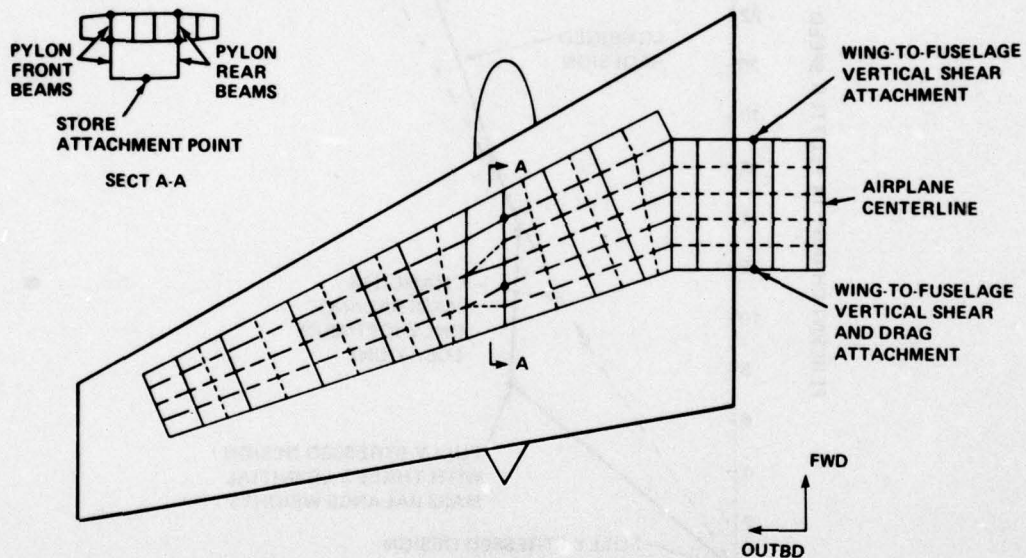

1922-18

FIGURE 16. Wing-with-Store Structures Model

This high store inertia created a critical flutter mechanism involving the first wing bending mode and the store-pitch/ wing-torsion mode. A flutter-critical flight condition was designated for the redesign study, the objective being to achieve a flutter-speed target of 660 knots equivalent airspeed from an initial computed value of 270 knots for the fully stressed design. After eliminating the posts connecting upper- and lower-cover node points as candidates for flutter resizing, the model contained 453 active structural design variables.

Convergence to the final design was achieved in eight combined strength/ flutter redesign cycles, achieving the required flutter speed with a weight increase of 8.4 lb. FIGURE 17 shows the elements that were resized for flutter and the percentages of the total weight increment that went into each. It may be noted that a total of 63% of the 8.4 lb increment went into stiffening the pylon front and rear beams. No structural elements were resized outboard of the wing store station. Resizing of wing structural elements inboard of this station involved spar webs and the rib webs between the wing-to-pylon connection points. The resizing in the vicinity of the front wing-to-fuselage connection point accounted for a relatively small proportion of the over-all weight increase.

One of the more interesting results of this study was that resizing to increase over-all store pitch stiffness was achieved more efficiently by increasing the gages of the wing spar webs than by resizing the covers. Another interesting result is that while the addition of material for flutter requirements caused some redistribution of cover material in the inboard regions of the wing, the net reduction in weight of the strength-critical structure was relatively insignificant.

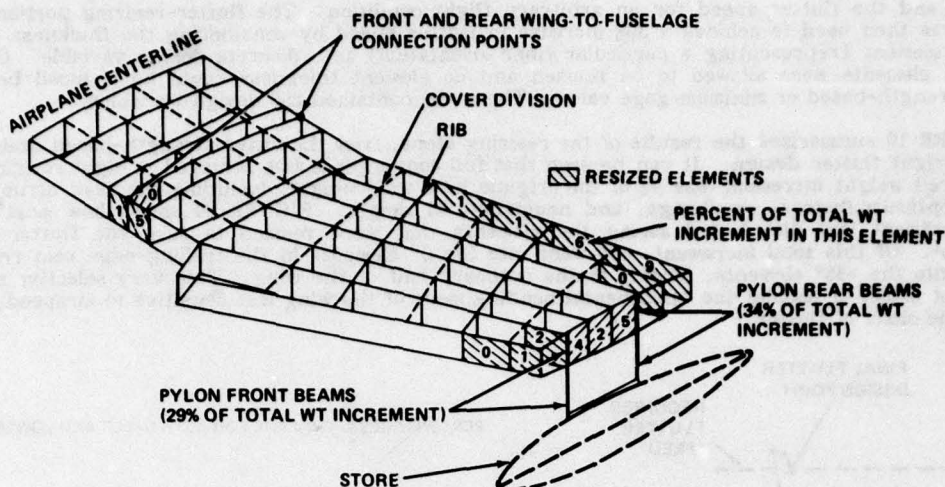

1922-19

FIGURE 17. Design Changes in Wing with Store

To illustrate an application of the FASTOP flutter resizing algorithm to a structure built from advanced composite materials, a simple preliminary-design representation of a wing was considered. Its aerodynamic planform and primary structural arrangement are shown in FIGURE 18, along with the four fiber directions of the laminated cover skins. The primary structure was a two-cell symmetric box beam built in at the root. Its graphite/epoxy cover skins were modeled with stacked orthotropic membrane elements representing material in each of the four fiber directions. The aluminum substructure was modeled with shear-panel elements and posts.

Since the strength resizing module of FASTOP cannot deal effectively with composite materials, the initial design-load computation and strength sizing for the wing were performed with other Grumman programs. FASTOP was then used to compute a dynamics model flexibility matrix, normal modes of

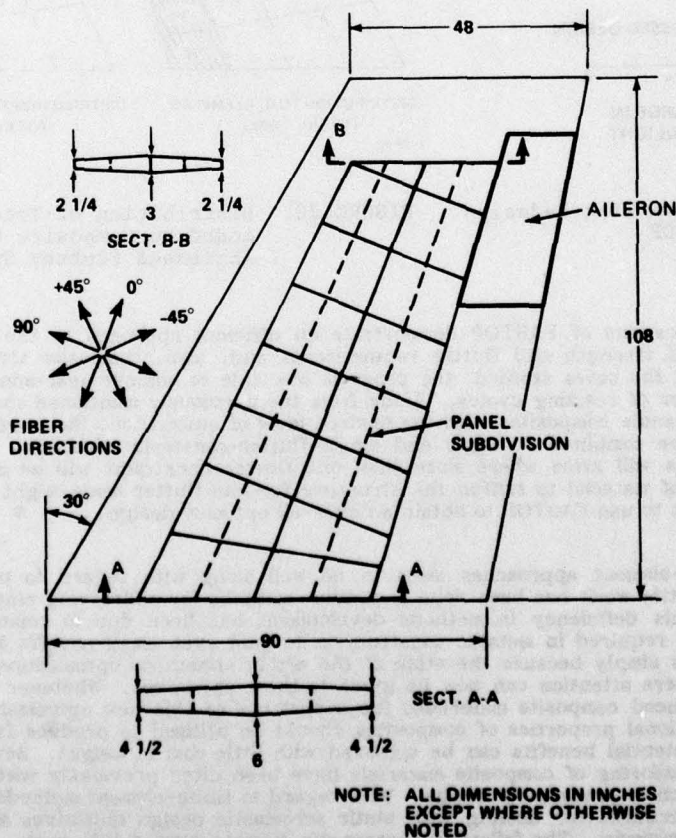

1922-20

FIGURE 18. Aerodynamic Planform and Primary Structural Arrangement of Composite Wing

vibration, and the flutter speed for an arbitrary flight condition. The flutter-resizing portion of the program was then used to achieve a 30% increase in flutter speed by considering the thickness of each membrane element (representing a particular fiber orientation) as a discrete design variable. Only the cover-skin elements were allowed to be resized and no element thickness could be reduced below its original strength-based or minimum-gage value. The model contained 256 design variables.

FIGURE 19 summarizes the results of the resizing steps, from the initial strength-based design to the minimum-weight flutter design. It can be seen that full convergence was achieved in eight resizing steps. The required weight increment was 4% of the original total wing weight, including the basic structural box with non-optimum factors, overhangs, and nonstructural weight. FIGURE 20 shows how most of this weight increment was distributed among the elements that were resized to meet the flutter-speed requirement. Of this total increment, 60% went into the  $0^\circ$  elements in the trailing-edge root region and 36% went into the  $-45^\circ$  elements, largely in the outboard half of the wing. This very selective stiffening had the net effect of making the fundamental bending mode of the wing less sensitive to airspeed, thereby delaying the onset of flutter.

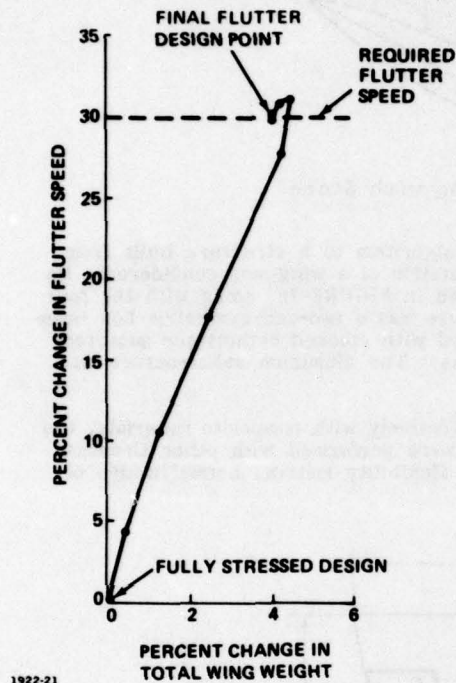

1922-21

FIGURE 19. Composite-Wing Redesign by FASTOP

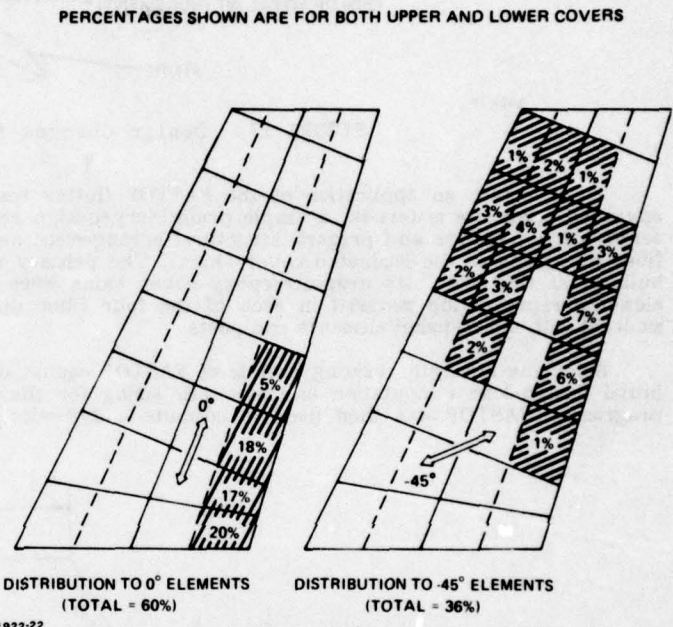

1922-22

FIGURE 20. Distribution of Total Weight Increment Added to Composite Cover Skins for Increased Flutter Speed

These three applications of FASTOP demonstrate an efficient approach to the sizing of metallic structures for combined strength and flutter requirements and, also, composite structures for flutter requirements. In all of the cases studied, the program was able to achieve near-minimum-weight designs with only a small number of resizing cycles. Aside from the previously mentioned shortcoming relating to FASTOP's inability to handle composites with the desired level of automation, the program appears to offer a sound approach to the combined strength and single-flutter-constraint problem. It is recognized, however, that situations will arise where more than one flutter constraint will be important. In such instances the addition of material to stiffen the structure for one flutter mode might aggravate another mode, making it difficult to use FASTOP to obtain an over-all optimum design.

While these finite-element approaches seem to be well along with regard to problems involving strength and flutter, little work has been done to provide methods for addressing static aeroelastic design objectives. Perhaps this deficiency in methods development has been due to relatively high weight penalties that might be required in metallic construction to gain even small payoffs in static aeroelastic behavior. Perhaps it is simply because the state of the art in structural optimization technology has just arrived at the point where attention can now be given to these objectives. Whatever the reason, with the increasing use of advanced composite materials, the importance of this new optimization area should be recognized. The directional properties of composites should be utilized to produce favorable aeroelastic behavior wherever substantial benefits can be achieved with little cost in weight. Several of the potential benefits of aeroelastic tailoring of composite materials have been cited previously with regard to the TSO program and its approach to preliminary design. With regard to finite-element methods, however, the only known optimization procedures for dealing with static aeroelastic design objectives are those which are under development at Grumman. The following paragraphs discuss some of this work.

Based on the success of the simple flutter resizing approach used in FASTOP and the generality of the procedure, it was natural to pursue its application to meeting other aeroelastic design objectives. Consequently, effort was devoted to formulating expressions for the derivatives of various static

aeroelastic parameters for use in recurrence equations similar to that used for flutter. This led to the development of one formal procedure [43] for addressing generalized displacement requirements (e.g., twist at a specified wing station) and a pilot computer program which can address any one of the following static aeroelastic design objectives:

- Improved control-surface effectiveness
- Improved lift-curve slope
- Increased divergence velocity.

To illustrate the use of one of these procedures, we consider the problem of resizing the previously discussed composite wing (see FIGURE 18) to improve its aileron effectiveness.

An analysis of the strength-based design revealed that the aeroelastically corrected pressure distribution associated with an imposed aileron rotation produced an aircraft roll moment that was only 17% of the rigid-wing value (at Mach 0.9, sea level). The automated resizing approach was then applied to increase the aileron effectiveness to an arbitrary value of 50%. As an expediency, because of a lack of the required level of automation, interaction between strength and aeroelastic resizing was ignored. However, no element thickness was permitted to be reduced below its strength design value. As before, only cover-skin elements were treated as design variables.

FIGURE 21 summarizes the results of the resizing cycles (obtained in a single computer submission) from the initial fully stressed design to a minimum-weight design having the desired aileron effectiveness. It may be noted that full convergence was obtained in only five resizing steps, with an attendant weight increment of about 4% of the total wing weight.

FIGURE 22 shows how most of the weight increment was distributed among elements that were resized to meet the requirement for aileron effectiveness. Of the total increment, 90% went into the  $-45^\circ$  elements in the outer two-thirds region of the wing, and 8% went into the  $0^\circ$  elements of the trailing-edge root region. This stiffening had the effect of increasing the wing torsional stiffness while also inducing favorable bending/twisting coupling to reduce the washout that is characteristic of swept surfaces.

While this work appears promising, it is recognized that the optimum material distribution for meeting a selected static aeroelastic design objective may be in conflict with that required to meet flutter requirements. Accordingly, future methods development work in this area should address static aeroelastic design objectives in combination with meeting flutter and strength requirements. This will require that attention be given to extending finite-element optimization techniques to enable treatment of multiple, interactive, aeroelastic constraints in combination with strength requirements. References 44 and 45 offer approaches to this problem.

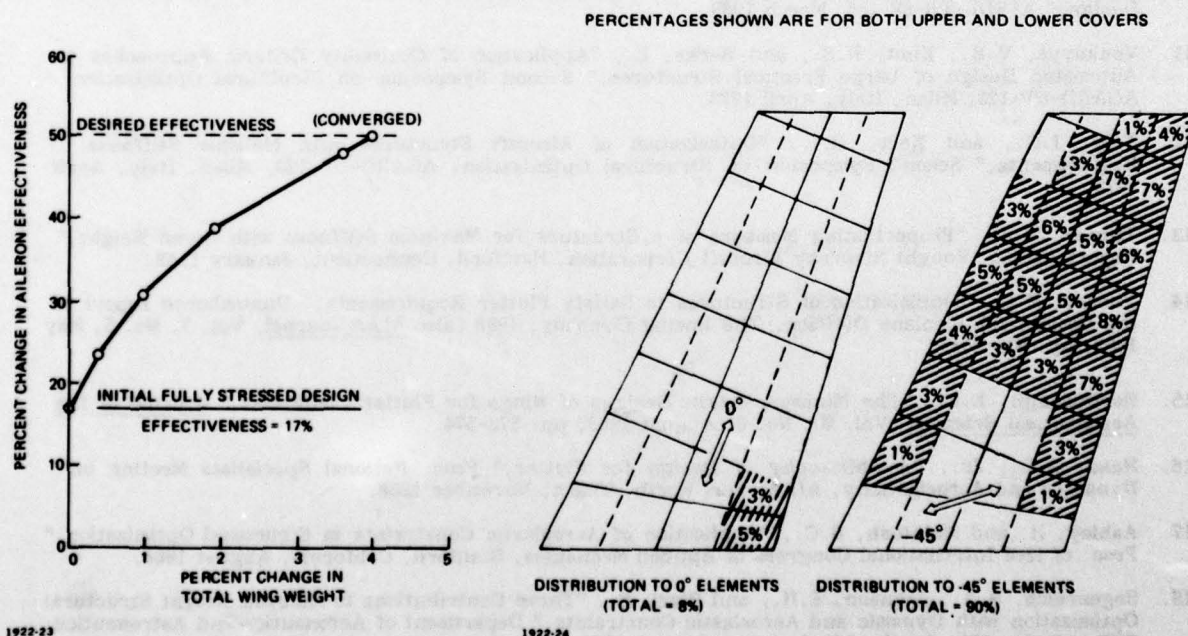

FIGURE 21. Summary of Resizing Steps for Increased Aileron Effectiveness

FIGURE 22. Distribution of Weight Increment Among Elements Resized for Increased Aileron Effectiveness

#### CONCLUDING REMARKS

During the last ten years, NASA, the U.S. Air Force, and the U.S. airframe industry have invested considerable resources in the development of automated structural design and analysis methods. To date, a number of impressive interdisciplinary design studies have been completed which clearly indicate the

benefits of such methods. Although further research in a number of problem areas is needed, a major impetus is now required to transfer this technology from design study use by the method developers to actual hardware application.

Structural optimization technology should continue to develop during the next ten years with increased emphasis on large-scale applications. Interactive computer aided design will become more commonplace for definition, analysis, and resizing of structural models. Further computer hardware development and acceptance by designers of new analytical tools are key factors to the success of this technology.

#### REFERENCES

1. Wasiutynski, Z., and Brandt, A., "The Present State of Knowledge in the Field of Optimum Design of Structures," Applied Mechanics Reviews, Vol. 16, No. 5, May 1963, pp. 341-348.
2. Sheu, C.Y., and Prager, W., "Recent Developments in Optimal Structural Design," Applied Mechanics Reviews, Vol. 21, No. 10, October 1968, pp. 985-992.
3. Berke, L., and Khot, N.S., "Use of Optimality Criteria Methods for Large Scale Systems," AGARD Lecture Series No. 70, 10-18 October 1974 (also AFFDL-TM-74-70-FBR, April 1974).
4. Stroud, W.J., "Automated Structural Design with Aeroelastic Constraints: A Review and Assessment of the State of the Art," AMD Vol. 7 - Structural Optimization Symposium, ASME, New York, November 1974.
5. Schmit, L.A., "Structural Synthesis from Abstract Concept to Practical Tool - Synopsis," Proc. AIAA/ASME 18th Structures, Structural Dynamics and Materials Conference, San Diego, California, March 1977.
6. Razani, R., "The Behavior of the Fully-Stressed Design of Structures and its Relationship to Minimum Weight Design," AIAA Journal, Vol. 3, No. 12, December 1965, pp. 2262-2268.
7. Schmit, L.A., "Structural Design by Systematic Synthesis," Proc. 2nd Conference on Electronic Computation, ASCE, Pittsburg, Pennsylvania, September 1960.
8. Schmit, L.A., "Structural Engineering Applications of Mathematical Programming Techniques," Symposium on Structural Optimization, AGARD-CP-36-70, Istanbul, Turkey, October 1969.
9. Pope, G.G. and Schmit, L.A., editors, "Structural Design Applications of Mathematical Programming Methods," AGARDograph No. 149, February 1971.
10. Venkayya, V.B., Khot, N.S., and Reddy, V.S., "Energy Distribution in an Optimum Structural Design," AFFDL-TR-68-156, March 1969.
11. Venkayya, V.B., Khot, N.S., and Berke, L., "Application of Optimality Criteria Approaches to Automated Design of Large Practical Structures," Second Symposium on Structural Optimization, AGARD-CP-123, Milan, Italy, April 1973.
12. Taig, I.C., and Kerr, R.I., "Optimization of Aircraft Structures with Multiple Stiffness Requirements," Second Symposium on Structural Optimization, AGARD-CP-123, Milan, Italy, April 1973.
13. Turner, M.J., "Proportioning Members of a Structure for Maximum Stiffness with Given Weight," Report ANC-5, Vought Sikorsky Aircraft Corporation, Hartford, Connecticut, January 1942.
14. Turner, M.J., "Optimization of Structures to Satisfy Flutter Requirements," Unnumbered report of the Commercial Airplane Division, The Boeing Company, 1968 (also AIAA Journal, Vol. 7, No. 5, May 1969, pp. 945-951).
15. MacDonough, E.P., "The Minimum Weight Designs of Wings for Flutter Conditions," Journal of the Aeronautical Sciences, Vol. 20, No. 8, August 1953, pp. 573-574.
16. Head, A.L., Jr., "A Philosophy of Design for Flutter," Proc. National Specialists Meeting on Dynamics and Aeroelasticity, AIAA, Fort Worth, Texas, November 1958.
17. Ashley, H. and McIntosh, S.C., "Application of Aeroelastic Constraints in Structural Optimization," Proc. of 12th International Congress of Applied Mechanics, Stanford, California, August 1968.
18. Segenreich, S.A., Johnson, E.H., and Rizzi, P., "Three Contributions to Minimum Weight Structural Optimization with Dynamic and Aeroelastic Constraints," Department of Aeronautics and Astronautics, SUDAAR No. 501, Stanford University, August 1976.
19. Turner, M.J., and Bartley, J.B., "Flutter Prevention in the Design of the SST," Proc. of Symposium on the Dynamic Response of Structures, Stanford, California, June 1971.
20. Triplett, W.E., and Ising, K.D., "Computer Aided Design Including Aeroelastic Constraints," Journal of Aircraft, Vol. 8, No. 7, July 1971, pp. 554-561.
21. Stroud, W.J., Dexter, C.B., and Stein, M., "Automated Preliminary Design of Simplified Wing Structures to Satisfy Flutter and Strength Requirements," NASA TN D-6534, December 1971.

22. Fiacco, A., and McCormick, G.P., Nonlinear Programming: Sequential Unconstrained Minimization Techniques, John Wiley & Sons, New York, 1968.
23. McCullers, L.A., and Lynch, R.W., "Composite Wing Design for Aeroelastic Requirements," Proc. of the Conference on Fibrous Composites in Flight Vehicle Design, AFFDL-TR-72-130, Dayton, Ohio, September 1972.
24. Haftka, R.T., "Automated Procedure for Design of Wing Structures to Satisfy Strength and Flutter Requirements," NASA TN D-7262, July 1973.
25. Rudisill, C.S., and Bhatia, K.G., "Optimization of Complex Structures to Satisfy Flutter Requirements," AIAA Journal, Vol. 9, No. 8, August 1971, pp. 1487-1491.
26. Haftka, R.T., and Yates, E.C., Jr., "On Repetitive Flutter Calculations in Structural Design," Proc. of the AIAA 12th Aerospace Sciences Meeting, Washington, D.C., January 1974.
27. O'Connell, R.F., Radovcich, N.A., and Hassig, H.J., "Structural Optimization with Flutter Speed Constraints Using Maximized Step Size," Journal of Aircraft, Vol. 14, No. 1, January 1977, pp. 85-94.
28. Siegel, S., "A Flutter Optimization Program for Aircraft Structural Design," Proc. of AIAA 4th Aircraft Design, Flight Test, and Operations Meeting, Los Angeles, California, August 1972.
29. Pines, S., and Newman, M., "Structural Optimization for Aeroelastic Requirements," Proc. of the AIAA/ASME/SAE 14th Structures, Structural Dynamics and Materials Conference, Williamsburg, Virginia, March 1973.
30. Kiusalaas, J., "Minimum Weight Design of Structures via Optimality Criteria," NASA TN D-7115, December 1972.
31. Segenreich, S.A., and McIntosh, S.C., "Weight Minimization of Structures for Fixed Flutter Speed via an Optimality Criterion," Proc. of AIAA/ASME/SAE 16th Structures, Structural Dynamics, and Materials Conference, Denver, Colorado, May 1975.
32. Wilkinson, K., Lerner, E., and Taylor, R.F., "Practical Design of Minimum-Weight Aircraft Structures for Strength and Flutter Requirements," Journal of Aircraft, Vol. 13, No. 8, August 1976, pp. 614-624.
33. Austin, F., et al., "Aeroelastic Tailoring of Advanced Composite Lifting Surfaces in Preliminary Design," Proc. AIAA/ASME/SAE 17th Structures, Structural Dynamics, and Materials Conference, Valley Forge, Pennsylvania, May 1976.
34. Lynch, R. W. and Rogers, W.A., "Aeroelastic Tailoring of Composite Materials to Improve Performance," Proc. AIAA/ASME/SAE 17th Structures, Structural Dynamics, and Materials Conference, Valley Forge, Pennsylvania, May 1976.
35. Lynch, R. W., Rogers, W. A., and Brayman, W. W., "An Integrated Capability for the Preliminary Design of Aeroelastically Tailored Wings," Paper No. 76-912, AIAA 1976 Aircraft Systems and Technology Meeting, Dallas, Texas, September 1976.
36. Wallerstein, D. V., and Haggemacher, G. W., "Automated Fully Stressed Design with NASTRAN," NASTRAN: User's Experiences, NASA TM X-3428, Fifth Colloquium, Ames Research Center, Moffett Field, California, October 1976, pp 53-65.
37. O'Connell, R. F., "Incremented Flutter Analysis," Journal of Aircraft, Vol. 11, No. 4, April 1974, pp. 236-240.
38. Sakata, I. F., Davis, G. W., Robinson, J. C., and Yates, E. C., Jr., "Design Study of Structural Concepts for an Arrow-Wing Supersonic-Cruise Aircraft," Paper No. 75-1037, AIAA 1975 Aircraft Systems and Technology Meeting, Los Angeles, California, August 1975.
39. Robinson, J. C., Yates, E. C., Jr., Turner, M. J., and Grande, D. L., "Application of an Advanced Computerized Structural Design System to an Arrow-Wing Supersonic Cruise Aircraft," Paper No. 75-1038, AIAA 1975 Aircraft Systems and Technology Meeting, Los Angeles, California, August 1975.
40. Thomas, R. M., et al., "Aircraft Strength and Stiffness Design Automation," U. S. - Japan Design Automation Symposium, Tokyo, Japan, August 1975.
41. Wilkinson, K., Markowitz, J., Lerner, E., George, D. and Batill, S.M., "FASTOP: A Flutter and Strength Optimization Program for Lifting-Surface Structures," Journal of Aircraft, Vol. 14, No. 6, June 1977, pp. 581-587.
42. Dwyer, W., Rosenbaum, J., Shulman, M., and Pardo, H., "Fully Stressed Design of Airframe Redundant Structures," Proc. of the Second Conference on Matrix Methods in Structural Mechanics, AFFDL-TR-68-150, October 1968.
43. Isakson, G., Pardo, H., Lerner, E., and Venkayya, V. B., "ASOP-3: A Program for the Optimum Design of Metallic and Composite Structures Subjected to Strength and Deflection Constraints," Paper No. 77-378, AIAA/ASME/SAE 18th Structures, Structural Dynamics, and Materials Conference, San Diego, California, March 1977.

- 44. Rizzi, P., "Optimization of Multi-Constrained Structures Based on Optimality Criteria," Proc. AIAA/ASME/SAE 17th Structures, Structural Dynamics, and Materials Conference, Valley Forge, Pennsylvania, May 1976.
- 45. Austin, F., "A Rapid Optimization Procedure for Structures Subjected to Multiple Constraints," Paper No. 77-374, AIAA/ASME/SAE 18th Structures, Structural Dynamics, and Materials Conference, San Diego, California, March 1977.

**REPORT DOCUMENTATION PAGE**

1. Recipient's Reference	2. Originator's Reference <b>(14)</b> AGARD-R-664 <sup>v</sup>	3. Further Reference ISBN 92-835-1269-3	4. Security Classification of Document UNCLASSIFIED
5. Originator √ Advisory Group for Aerospace Research and Development North Atlantic Treaty Organization 7 rue Ancelle, 92200 Neuilly sur Seine, France			
6. Title <b>(6)</b>	APPLICATIONS OF STRUCTURAL OPTIMIZATION FOR STRENGTH AND AEROELASTIC DESIGN REQUIREMENTS		
7. Presented at the 45th Structures and Materials Panel Meeting, (USA) Voss, Norway, September 1977.			
8. Author(s) <b>(10)</b>	Wagner, Edwin & Ronald Lansing*, Lerner* & F. Taylor†		9. Date <b>(11)</b> Jan 1978
10. Author's Address * Grumman Aerospace Corporation Bethpage, New York 11714, USA		† USAF Flight Dynamics Lab. Wright-Patterson AFB, Ohio 45433, USA	11. Pages <b>(12)</b> 26 p.
12. Distribution Statement This document is distributed in accordance with AGARD policies and regulations, which are outlined on the Outside Back Covers of all AGARD publications.			
13. Keywords/Descriptors Aeroelasticity                      Design criteria                      Optimization Loads (forces)                      Structural design Aerodynamic loads                      Structural analysis			
14. Abstract ↓ The purpose of this paper is to review the progress that has been made in structural optimization techniques during the last few years. The paper concentrates on the use of optimization in the design of structures from the point of view of aeroelasticity, taking into account the constraints due to loads. It gives a survey of the efforts that have been achieved in the main US firms and organizations and shows that most of the techniques are now at the stage where they are used, or can be used, for actual design. ↖			

400043

self

<p>AGARD Report No.664 Advisory Group for Aerospace Research and Development, NATO <b>APPLICATIONS OF STRUCTURAL OPTIMIZATION FOR STRENGTH AND AEROELASTIC DESIGN REQUIREMENTS</b> W.Lansing, E.Lerner and R.F.Taylor Published January 1978 26 pages</p> <p>The purpose of this paper is to review the progress that has been made in structural optimization techniques during the last few years. The paper concentrates on the use of optimization in the design of structures from the point of view of aeroelasticity, taking into account the constraints due to loads. It gives a survey of the</p> <p>P.T.O.</p>	<p>AGARD-R-664</p> <p>Aeroelasticity Loads (forces) Aerodynamic loads Design criteria Structural design Structural analysis Optimization</p>	<p>AGARD Report No.664 Advisory Group for Aerospace Research and Development, NATO <b>APPLICATIONS OF STRUCTURAL OPTIMIZATION FOR STRENGTH AND AEROELASTIC DESIGN REQUIREMENTS</b> W.Lansing, E.Lerner and R.F.Taylor Published January 1978 26 pages</p> <p>The purpose of this paper is to review the progress that has been made in structural optimization techniques during the last few years. The paper concentrates on the use of optimization in the design of structures from the point of view of aeroelasticity, taking into account the constraints due to loads. It gives a survey of the</p> <p>P.T.O.</p>	<p>AGARD-R-664</p> <p>Aeroelasticity Loads (forces) Aerodynamic loads Design criteria Structural design Structural analysis Optimization</p>
<p>AGARD Report No.664 Advisory Group for Aerospace Research and Development, NATO <b>APPLICATIONS OF STRUCTURAL OPTIMIZATION FOR STRENGTH AND AEROELASTIC DESIGN REQUIREMENTS</b> W.Lansing, E.Lerner and R.F.Taylor Published January 1978 26 pages</p> <p>The purpose of this paper is to review the progress that has been made in structural optimization techniques during the last few years. The paper concentrates on the use of optimization in the design of structures from the point of view of aeroelasticity, taking into account the constraints due to loads. It gives a survey of the</p> <p>P.T.O.</p>	<p>AGARD-R-664</p> <p>Aeroelasticity Loads (forces) Aerodynamic loads Design criteria Structural design Structural analysis Optimization</p>	<p>AGARD Report No.664 Advisory Group for Aerospace Research and Development, NATO <b>APPLICATIONS OF STRUCTURAL OPTIMIZATION FOR STRENGTH AND AEROELASTIC DESIGN REQUIREMENTS</b> W.Lansing, E.Lerner and R.F.Taylor Published January 1978 26 pages</p> <p>The purpose of this paper is to review the progress that has been made in structural optimization techniques during the last few years. The paper concentrates on the use of optimization in the design of structures from the point of view of aeroelasticity, taking into account the constraints due to loads. It gives a survey of the</p> <p>P.T.O.</p>	<p>AGARD-R-664</p> <p>Aeroelasticity Loads (forces) Aerodynamic loads Design criteria Structural design Structural analysis Optimization</p>

<p>efforts that have been achieved in the main US firms and organizations and shows that most of the techniques are now at the stage where they are used, or can be used, for actual design.</p> <p>Paper presented at the 45th Structures and Materials Panel Meeting, Voss, Norway, September 1977.</p> <p>ISBN 92-835-1269-3</p>	<p>efforts that have been achieved in the main US firms and organizations and shows that most of the techniques are now at the stage where they are used, or can be used, for actual design.</p> <p>Paper presented at the 45th Structures and Materials Panel Meeting, Voss, Norway, September 1977.</p> <p>ISBN 92-835-1269-3</p>
<p>efforts that have been achieved in the main US firms and organizations and shows that most of the techniques are now at the stage where they are used, or can be used, for actual design.</p> <p>Paper presented at the 45th Structures and Materials Panel Meeting, Voss, Norway, September 1977.</p> <p>ISBN 92-835-1269-3</p>	<p>efforts that have been achieved in the main US firms and organizations and shows that most of the techniques are now at the stage where they are used, or can be used, for actual design.</p> <p>Paper presented at the 45th Structures and Materials Panel Meeting, Voss, Norway, September 1977.</p> <p>ISBN 92-835-1269-3</p>

**AGARD**

NATO  OTAN

7. RUE ANCELLE · 92200 NEUILLY-SUR-SEINE  
FRANCE

Telephone 745.08.10 · Telex 610178

**DISTRIBUTION OF UNCLASSIFIED  
AGARD PUBLICATIONS**

AGARD does NOT hold stocks of AGARD publications at the above address for general distribution. Initial distribution of AGARD publications is made to AGARD Member Nations through the following National Distribution Centres. Further copies are sometimes available from these Centres, but if not may be purchased in Microfiche or Photocopy form from the Purchase Agencies listed below.

NATIONAL DISTRIBUTION CENTRES

**BELGIUM**

Coordonnateur AGARD - VSL  
Etat-Major de la Force Adrienne  
Quartier Reims Elisabeth  
Rue d'Evans, 1140 Bruxelles

**CANADA**

Defence Scientific Information Service  
Department of National Defence  
Ottawa, Ontario K1A 0Z2

**DENMARK**

Danish Defence Research Board  
Østerbrogades Kaserne  
Copenhagen Ø

**FRANCE**

O.N.E.R.A. (Direction)  
29 Avenue de la Division Leclerc  
92 Châtillon sous Bagneux

**GERMANY**

Zentralstelle für Luft- und Raumfahrt-  
dokumentation und -information  
Postfach 860880  
D-8 München 86

**GREECE**

Hellenic Armed Forces Command  
D Branch, Athens

**ICELAND**

Director of Aviation  
c/o Flugrad  
Reykjavik

**UNITED STATES**

National Aeronautics and Space Administration (NASA),  
Langley Field, Virginia 23365  
Attn: Report Distribution and Storage Unit

**THE UNITED STATES NATIONAL DISTRIBUTION CENTRE (NASA) DOES NOT HOLD  
STOCKS OF AGARD PUBLICATIONS, AND APPLICATIONS FOR COPIES SHOULD BE MADE  
DIRECT TO THE NATIONAL TECHNICAL INFORMATION SERVICE (NTIS) AT THE ADDRESS BELOW.**

PURCHASE AGENCIES

*Microfiche or Photocopy*

National Technical  
Information Service (NTIS)  
5285 Port Royal Road  
Springfield  
Virginia 22151, USA

*Microfiche*

Space Documentation Service  
European Space Agency  
10, rue Mario Nikis  
75015 Paris, France

*Microfiche*

Technology Reports  
Centre (DIT)  
Station Square House  
St. Mary Cray  
Orpington, Kent BR3 3RF  
England

Requests for microfiche or photocopies of AGARD documents should include the AGARD serial number, title, author or editor, and publication date. Requests to NTIS should include the NASA accession report number. Full bibliographical references and abstracts of AGARD publications are given in the following journals:

Scientific and Technical Aerospace Reports (STAR),  
published by NASA Scientific and Technical  
Information Facility  
Post Office Box 8757  
Baltimore/Washington International Airport  
Maryland 21240, USA

Government Reports Announcements (GRA),  
published by the National Technical  
Information Service, Springfield  
Virginia 22151, USA