

AD-A050 480

HUGHES RESEARCH LABS MALIBU CALIF
OPTICAL-MICROWAVE INTERACTIONS IN SEMICONDUCTOR DEVICES.(U)
OCT 77 H YEN, M BARNOSKI

F/G 20/5

N00173-77-C-0156

UNCLASSIFIED

NL

| OF |
AD
A050480



END
DATE
FILMED
3-78
DDC

AD-A050480

1

OPTICAL-MICROWAVE INTERACTIONS IN SEMICONDUCTOR DEVICES

Huan-Wun Yen and Mike Barnoski

Hughes Research Laboratories
3011 Malibu Canyon Road
Malibu, CA 90265

October 1977

Contract N00173-77-C-0156

Quarterly Report 1

For Period 17 June 1977 through 14 September 1977

Prepared for
NAVAL RESEARCH LABORATORY
4555 Overlook Avenue, S.W.
Washington, DC 20375

DISTRIBUTION STATEMENT A

Approved for public release;
Distribution Unlimited

DDC
RECEIVED
FEB 27 1978
RECEIVED
D

UNCLASSIFIED

SECURITY CLASSIFICATION OF THIS PAGE (When Data Entered)

REPORT DOCUMENTATION PAGE		READ INSTRUCTIONS BEFORE COMPLETING FORM
1. REPORT NUMBER	2. GOVT ACCESSION NO.	3. RECIPIENT'S CATALOG NUMBER
4. TITLE (and Subtitle) OPTICAL-MICROWAVE INTERACTIONS IN SEMICONDUCTOR DEVICES		5. TYPE OF REPORT & PERIOD COVERED Quarterly Report 1 17 June 77 - 14 Sept. 77
7. AUTHOR(s) Huan-Wun Yen and Mike Barnoski		6. PERFORMING ORG. REPORT NUMBER
9. PERFORMING ORGANIZATION NAME AND ADDRESS Hughes Research Laboratories 3011 Malibu Canyon Road Malibu, CA 90265		8. CONTRACT OR GRANT NUMBER(s) N00173-77-C-0156
11. CONTROLLING OFFICE NAME AND ADDRESS Naval Research Laboratory 4555 Overlook Ave., S.W. Washington, D.C. 20375		10. PROGRAM ELEMENT, PROJECT, TASK AREA & WORK UNIT NUMBERS
14. MONITORING AGENCY NAME & ADDRESS (if different from Controlling Office)		12. REPORT DATE October 1977
		13. NUMBER OF PAGES 38
		15. SECURITY CLASS. (of this report) Unclassified
		15a. DECLASSIFICATION DOWNGRADING SCHEDULE
16. DISTRIBUTION STATEMENT (of this Report) APPROVED FOR PUBLIC RELEASE DISTRIBUTION UNLIMITED		
17. DISTRIBUTION STATEMENT (of the abstract entered in Block 20, if different from Report)		
18. SUPPLEMENTARY NOTES		
19. KEY WORDS (Continue on reverse side if necessary and identify by block number) Optical-microwave interactions, Injection laser modulation, Oscillators, Optical injection locking		
20. ABSTRACT (Continue on reverse side if necessary and identify by block number) Theoretical and experimental studies of direct current modulation of semiconductor injection lasers were carried out. In the small signal approximation we found that the maximum usable frequency of modulation was limited to under 10 GHz. Experimentally we have demonstrated modulation of a single mode laser up to 3.4 GHz and was currently limited by our detection system. Optical injection locking experiments were		

UNCLASSIFIED

SECURITY CLASSIFICATION OF THIS PAGE(When Data Entered)

carried out at low frequencies (<2 GHz). Injection locking was observed not only at fundamental frequencies but also at various subharmonics with less tolerance in frequency deviation. It is also possible to achieve simultaneous switching and phase locking in these oscillators.

ADMISSION for	
DTIS	White Section <input checked="" type="checkbox"/>
DDG	Buff Section <input type="checkbox"/>
UNANNOUNCED JUSTIFICATION.....	
BY.....	
DISTRIBUTION/AVAILABILITY CODES	
Dist.	AVAIL. and/or SPECIAL
<input checked="" type="checkbox"/>	<input type="checkbox"/>

UNCLASSIFIED

SECURITY CLASSIFICATION OF THIS PAGE(When Data Entered)

PREFACE

The following personnel contributed to the research work reported here: H. W. Yen, M. K. Barnoski, A. Yariv (consulting), and D. F. Lewis. The single-mode laser was on loan from Caltech.

TABLE OF CONTENTS

SECTION		PAGE
	PREFACE	3
1	INTRODUCTION	6
2	THEORETICAL STUDY OF INJECTION LASER MODULATION . .	7
3	EXPERIMENTAL RESULTS OF INJECTION LASER MODULATION	17
4	SUMMARY OF OPTICAL INJECTION LOCKING EXPERIMENT AND DESIGN OF GaAs FET OSCILLATOR	29
5	PLANS FOR NEXT QUARTER	36
6	SUMMARY	37
	REFERENCES	38

LIST OF ILLUSTRATIONS

FIGURE		PAGE
1	Frequency dependence of the normalized modulation depth of an injection laser	11
2	Input-output characteristics of RCA stripe geometry laser	18
3	Schematic of the direct amplitude modulation of injection lasers	19
4	Pictures of modulated injection laser output	20
5	Channeled substrate single mode injection laser characteristics	25
6	Microwave modulated outputs of channeled substrate injection laser	26
7	Direct amplitude modulation of a single mode injection laser at 1 GHz with negligible distortion	28
8	Ic versus Vc characteristics curves of an rf transistor (2N 5108): (a) without illumination, (b) with illumination	30
9	Schematic of the experimental setup for optical injection locking experiment	31
10	Scope traces of optical injection locking of silicon transistor oscillator; (a) without illumination, (b) with illumination	33
11	Scope traces of simultaneous optical switching and injection locking of transistor oscillator; (a) without illumination, zero oscillator output, (b) with illumination, oscillator switched on and phase locked	35

SECTION 1

INTRODUCTION

The purpose of this program is to study the mechanism of optical-microwave interactions in semiconductor devices with a specific goal of demonstrating optical injection locking of microwave oscillators. During the first quarter our efforts have been directed toward the study of direct current modulation of GaAlAs semiconductor injection lasers. We have attacked the problem both theoretically and experimentally to determine the maximum modulation speed that one can expect from a semiconductor laser by direct current modulation. We also explored the possibility of using second-order mode locking as a way of achieving efficient laser modulation in the microwave frequency range.

Experiments were carried out on both multimode and single-mode lasers. Modulation frequency as high as 3.4 GHz was observed in the single-mode laser. However, the detector module used in these measurements has a 3 dB cutoff frequency of only 3.15 GHz. It is believed that this laser can be modulated at higher frequencies if a suitable detector is used. Currently, we are looking into various techniques of detecting microwave modulated optical signals.

Theoretical studies of the operation of IMPATT diodes and GaAs field effect transistors (FETs) under optical illumination are under way; results will be reported next quarter. The experimental results of optical injection locking of transistor oscillators to date are summarized in Section 4 where we also describe the current work on the design of a GaAs FET X-band oscillator to be used in the injection locking study.

SECTION 2

THEORETICAL STUDY OF INJECTION LASER MODULATION

The simplest way to modulate the optical output of an injection laser is by changing the laser current. For example, one can operate the injection laser in the pulsed mode by sending current pulses into the laser and obtain light pulses output. However, if a step current of amplitude I is applied to an injection laser, there will be a turn-on delay time associated with the corresponding optical signal output given by¹

$$t_d = \tau_s \ln[I/(I - I_{th})] ,$$

where τ_s is the spontaneous electron lifetime and I_{th} is the laser threshold current.

For GaAs lasers, τ_s is typically a few nanoseconds. Thus the turn-on delay for a pulsed laser is ~ 1 nsec. This means the maximum repetition rate of a pulsed laser is limited to below 1 GHz. The physical reason for the existence of turn-on delay is that it takes a finite time for the laser to accumulate enough electrons to reach the state of population inversion and hence lasing.

It is obvious that one should be able to eliminate t_d by prebiasing the laser up to I_{th} or even higher and superimpose the modulation current onto the bias to accomplish high frequency modulation. For a single-mode laser we can write the equations that describe the time behavior of the electron and photon density in the active region of the laser as follows:

$$\frac{dn}{dt} = \frac{I}{eV} - \frac{n}{\tau_s} - Gns \quad (1)$$

$$\frac{ds}{dt} = Gns - \frac{s}{\tau_p} \quad (2)$$

where n and s are electron density and photon density, respectively, τ_p is the photon lifetime in the optical cavity, e is the electronic charge, V is the volume of the active region, and G is a constant.

To find the steady-state values of n and s we let

$$\frac{dn}{dt} = \frac{ds}{dt} = 0$$

and obtain

$$n_0 = \frac{1}{G\tau_p} \quad (3)$$

and

$$s_0 = \tau_p \left(\frac{I_0}{eV} - \frac{n_0}{\tau_s} \right) \quad (4)$$

If the diode is biased just at threshold $I_0 = I_{th}$ and $s_0 \approx 0$, we have

$$I_{th} = \frac{n_0 eV}{\tau_s} = \frac{eV}{G\tau_p\tau_s} \quad (5)$$

By substituting equations (3) and (5) into (4), we can rewrite s_0 as

$$s_0 = \frac{1}{G\tau_s} \left(\frac{I_0}{I_{th}} - 1 \right) \cdot$$

For the case of small signal modulation we substitute

$$s = s_0 + \Delta s, \quad I = I_0 + \Delta I$$

and

$$n = n_0 + \Delta n$$

into equations (1) and (2) to give a set of second-order differential equations of the form

$$\frac{d^2}{dt^2} \begin{Bmatrix} \Delta n \\ \Delta s \end{Bmatrix} + \gamma \frac{d}{dt} \begin{Bmatrix} \Delta n \\ \Delta s \end{Bmatrix} + \omega_0^2 \begin{Bmatrix} \Delta n \\ \Delta s \end{Bmatrix} = \begin{Bmatrix} \frac{1}{eV} \frac{d\Delta I}{dt} \\ \frac{1}{\tau_p} \frac{\Delta I}{eV} \end{Bmatrix}, \quad (6)$$

(7)

where

$$\gamma = \frac{1}{\tau_s} [1 + (I_0/I_{th} - 1)] = \frac{1}{\tau_p} + \tau_p \omega_0^2$$

$$\omega_0^2 = \frac{1}{\tau_p \tau_s} \left(\frac{I_0}{I_{th}} - 1 \right). \quad (8)$$

Since the optical output of the laser is proportional to the photon density inside the cavity, solving equation (7) for Δs will give us the laser output small-signal modulation amplitude. Specifically, we are interested in sinusoidal modulation, so we set

$$I = I_0 + \Delta I = I_0 + I' e^{i\omega t}$$

and

$$\Delta s = s' e^{i\omega t}$$

where ω is the frequency of the applied modulation signal. It is easy to solve for s' as

$$s' = \frac{\frac{I'}{\tau_p eV}}{(\omega_0^2 - \omega^2) + i\gamma\omega}$$

A modulation depth function $F(\omega)$ is defined as

$$F(\omega) = \frac{s'(\omega)}{s_0}$$

Also, a normalized modulation depth $f(\omega)$ is defined as

$$f(\omega) = \frac{F(\omega)}{F(0)} = \frac{\omega_0^2}{[(\omega_0^2 - \omega^2)^2 + \gamma^2 \omega^2]^{1/2}} \quad (9)$$

A plot of equation (9) is shown in Figure 1. Here $\tau_p = 1$ psec and $\tau_s = 1$ nsec, with I/I_{th} as a parameter. It is clear from the plots that there is a resonance peak in the modulation depth curve. It occurs at

$$\omega = \omega_{\max} = \left(\omega_0^2 - \frac{\gamma^2}{2} \right)^{1/2}, \quad (10)$$

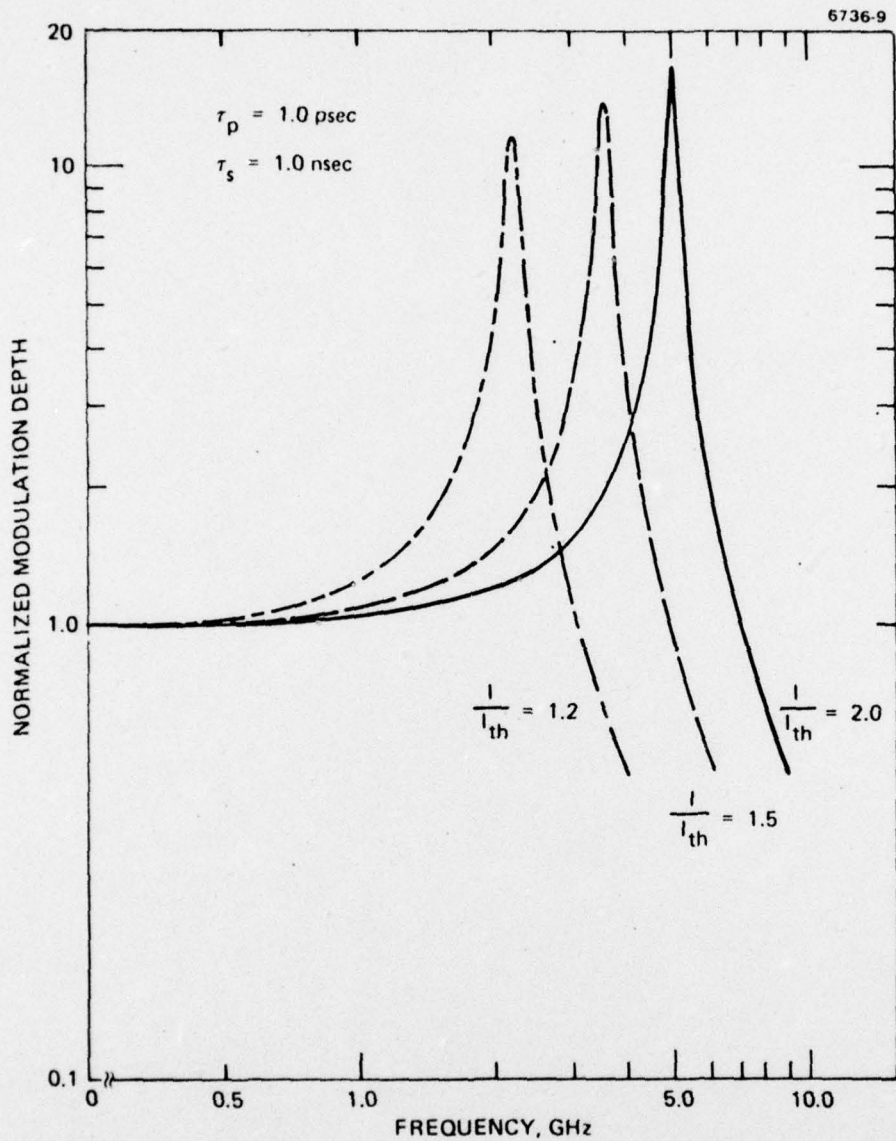

Figure 1. Frequency dependence of the normalized modulation depth of an injection laser.

and the modulation depth at this frequency can be more than ten times as large as that at low frequencies. We will arbitrarily define the maximum usable frequency of modulation to be the frequency so that $f(\omega) = 1$. This corresponds to

$$\omega_u^2 = 2 \left(\omega_0^2 - \frac{Y^2}{2} \right)$$

or

$$\omega_u = \sqrt{2} \omega_{\max} . \quad (11)$$

For example, in Figure 1 when $I/I_{th} = 2.0$ we have $\omega_{\max} \approx 5$ GHz and $\omega_u = 7.1$ GHz. Let us go back to the expression of small-signal resonance frequency of the laser

$$\omega_0^2 = \frac{1}{\tau_p \tau_s} \left(\frac{I}{I_{th}} - 1 \right) . \quad (8)$$

Since ω_0 is directly related to the maximum usable modulation frequency, we should try to make ω_0 as large as possible. In equation (8) τ_s is the spontaneous electron lifetime in the active region of the laser which is somewhat governed by the material property. It appears at first that we might be able to shorten τ_p , the photon lifetime, which is given by

$$\tau_p = \frac{L}{c (\alpha L - \ln R)} = \frac{1}{c \left(\alpha - \frac{1}{L} \ln R \right)} ,$$

where L is the laser cavity length, c is the speed of light in the laser medium, α is the optical loss per unit length in the laser, and

R is the reflectivity of the mirrors (assuming identical mirrors which is true in semiconductor lasers without coatings).

Unfortunately, the threshold of a semiconductor laser is directly proportional to

$$\left(\alpha - \frac{1}{L} \ln R\right)$$

and the threshold figures in the expression of resonance frequency also. By shortening τ_p , I_{th} will increase so that the product of τ_p and I_{th} stays almost constant. Therefore, there is little to gain by varying the device parameter. The only thing that can be done is to drive the laser harder and make I/I_{th} as large as possible. However, for most of the lasers, especially stripe geometry lasers, $I/I_{th} \approx 2$ is about as high as can be achieved safely. Thus according to the curves in Figure 1, the maximum usable frequency of modulation would be limited to about 10 GHz or less.

Besides direct current modulation, it is important to investigate other alternatives for efficient injection laser modulation. One of the possible approaches is the second-order mode locking. In ordinary mode locking, the frequency spacing between two adjacent longitudinal modes is required to be constant; that is

$$\omega_m - \omega_{m-1} = \frac{\pi c}{nL} = \text{constant} .$$

However, if the laser medium is dispersive it is possible that the second-order difference of the mode spacing is constant instead of the first-order difference; i.e.,

$$\Delta\omega_m - \Delta\omega_{m-1} = \text{constant}$$

where

$$\Delta\omega_m = \omega_m - \omega_{m-1} .$$

The condition for the presence of second-order mode locking is that the index of refraction of the laser medium is dispersive and has the form

$$n(\omega) = n_0 + a \omega .$$

The wave vector of the laser longitudinal modes satisfies the resonant condition in a cavity of length L:

$$k_m L = m \pi .$$

When we use the relation

$$k_m = \frac{\omega_m n}{c} ,$$

we have

$$\frac{\omega_m}{c} (n_0 + a \omega_m) L = m \pi$$

or

$$\left(\frac{aL}{c}\right) \omega_m^2 + \left(\frac{n_0 L}{c}\right) \omega_m - m \pi = 0 .$$

Solving for ω_m gives

$$\omega_m = \frac{-\left(\frac{n_0 L}{c}\right) + \sqrt{\left(\frac{n_0 L}{c}\right)^2 + \frac{4m\pi a L}{c}}}{2\left(\frac{aL}{c}\right)}$$

$$\approx m \left(\frac{\pi c}{n_0 L}\right) - m^2 \left(\frac{\pi^2 a c^2}{n_0^3 L^2}\right)$$

$$= mA - m^2 B ,$$

where

$$A = \frac{\pi c}{n_0 L} \quad \text{and} \quad B = \frac{\pi^2 a c^2}{n_0^3 L^2} = \frac{a}{n_0} A^2 .$$

If we assume that all the longitudinal modes of the laser have the same amplitude, then the total electric field inside the laser cavity can be written as

$$\begin{aligned} E(t) &= \sum_m E_m(t) = \sum_{m=-N/2}^{N/2} E_0 e^{i(\omega_0 + mA - m^2 B)t} \\ &= E_0 e^{i\omega_0 t} \sum_m e^{imAt} e^{-im^2 Bt} . \end{aligned}$$

If there is a time that

$$At = 2\pi s , \quad Bt = 2\pi g$$

where s and g are integers, then at that time every term inside the summation sign is unity and

$$E(t) = NE_0 e^{i\omega_0 t}.$$

Therefore, the condition for this to happen is

$$\frac{A}{B} = \frac{S}{g} \gg 1,$$

and giant optical pulses occur at times which are multiples of

$$T = \frac{2\pi S}{A} = \frac{2\pi g}{B}.$$

For example, if we take $g = 1$ and for GaAs lasers assume $n_0 = 3.6$, $L = 100 \mu\text{m}$, and $a \approx 10^{-15}$, we have

$$T = 3.3 \times 10^{-9} \text{ sec.}$$

Thus in some lasers it might be possible to adjust the device parameters so that the second-order mode-locking pulses occur at gigahertz rate which could be an alternative to the efficient laser modulation at microwave frequencies.

SECTION 3

EXPERIMENTAL RESULTS OF INJECTION LASER MODULATION

Direct current modulation experiments were carried out using an RCA commercial laser first. This is a stripe-geometry laser with a stripe width of $\sim 20 \mu\text{m}$. The transverse mode control is insufficient. As a result, the output optical power versus input dc current curve has several kinks in it which indicates different transverse mode excitation at different current levels. This is shown in Figure 2.

Amplitude modulation is accomplished by varying the current around a fixed bias point at the applied microwave frequencies as sketched in Figure 3. The signal generator used was a sweep oscillator and the detector used was a high-speed wideband (dc, to 3.15 GHz) silicon avalanche photodetector module. Some of the results are shown in Figure 4. Figure 4(a) shows the output of the laser modulated at 1 GHz with a modulation depth of $\sim 81\%$, Figure 4(b) shows modulation depth of $\sim 50\%$ at 2 GHz, Figure 4(c) shows $\sim 38\%$ modulation at 2.75 GHz, and Figure 4(d) shows $\sim 23\%$ modulation at 3 GHz. Note that these results were taken under different conditions in each case. They represent the best result achievable for the given signal frequency and power. The decreasing modulation depth as frequency goes up is partially due to the smaller rf power available at higher frequencies. This is compounded by the fact that our detector amplifier has a 3 dB rolloff point at about 3.15 GHz making it difficult to detect any modulation effect above 3.2 GHz in this laser.

During this study we also observed that the laser output sometimes was modulated at half the frequency of the input signal, depending on the signal power level and/or the laser bias current. For example, in Figure 4(e) the input signal was at 1 GHz but the laser output was modulated at 500 MHz if the signal level was low. In Figure 4(f) keeping the laser bias current unchanged we increased the input signal power and the laser output was modulated at 1 GHz. A similar situation is shown in Figures 4(g) and 4(h) where we kept the input signal power constant at 14 mW (2 GHz) while the laser bias current was varied from

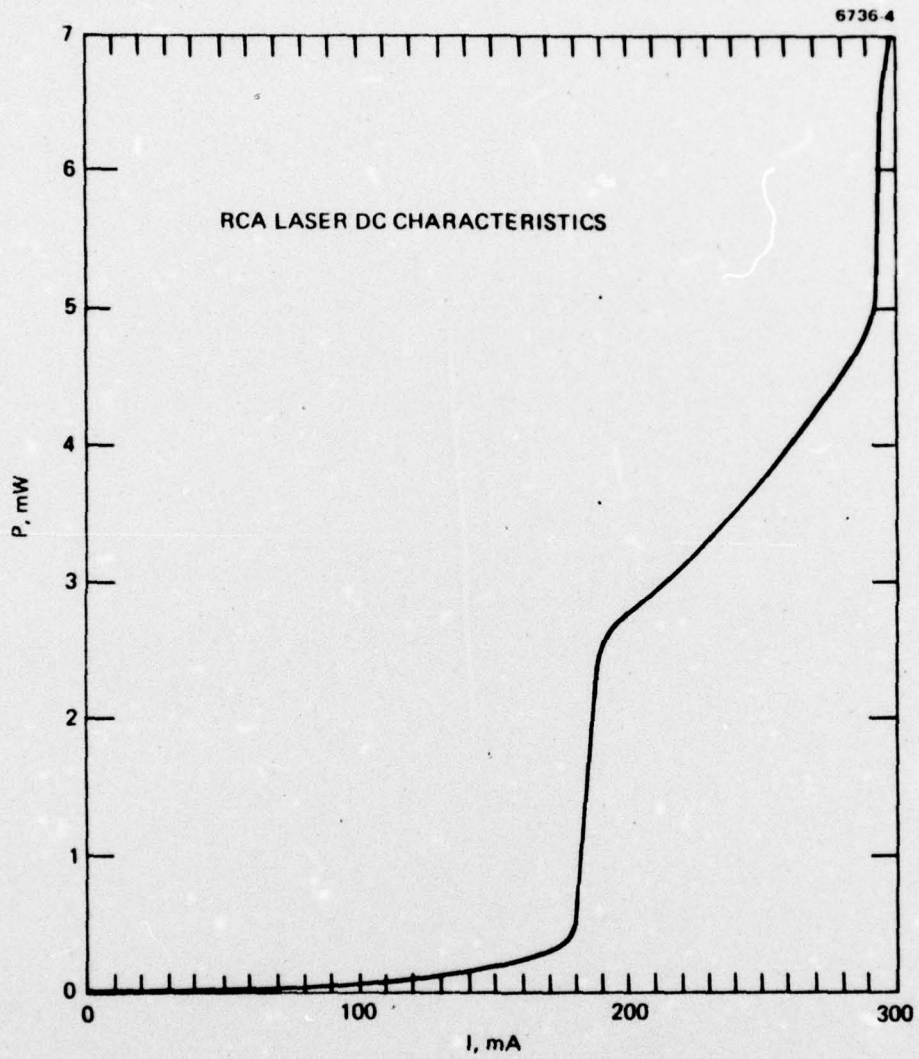

Figure 2. Input-output characteristics of RCA stripe geometry laser.

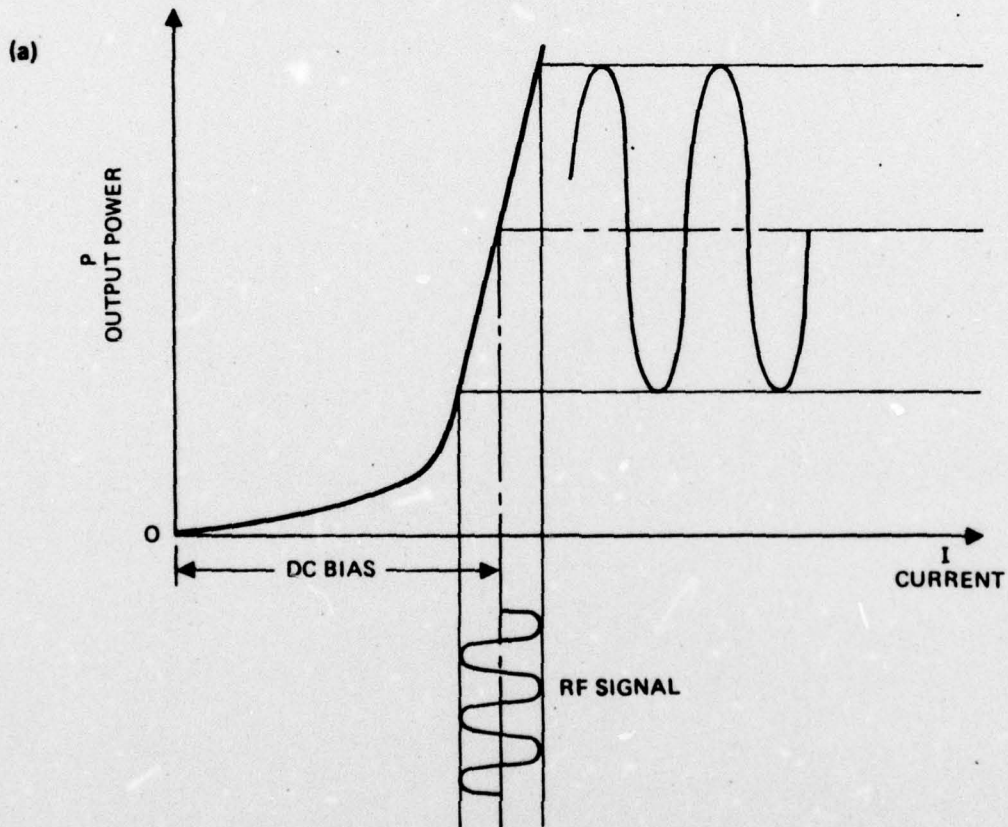
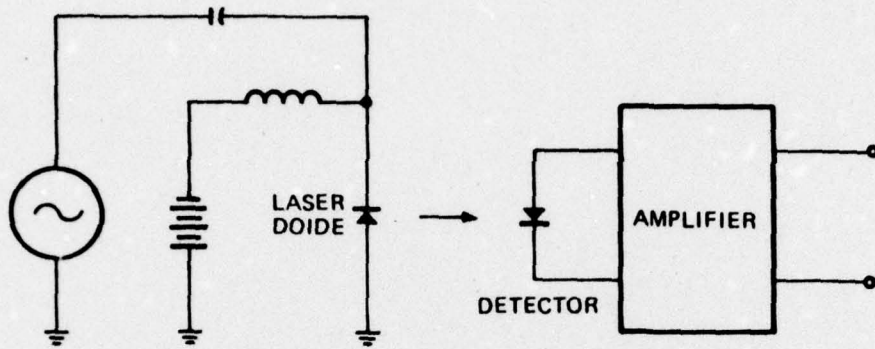

Figure 3. Schematic of the direct amplitude modulation of injection lasers.

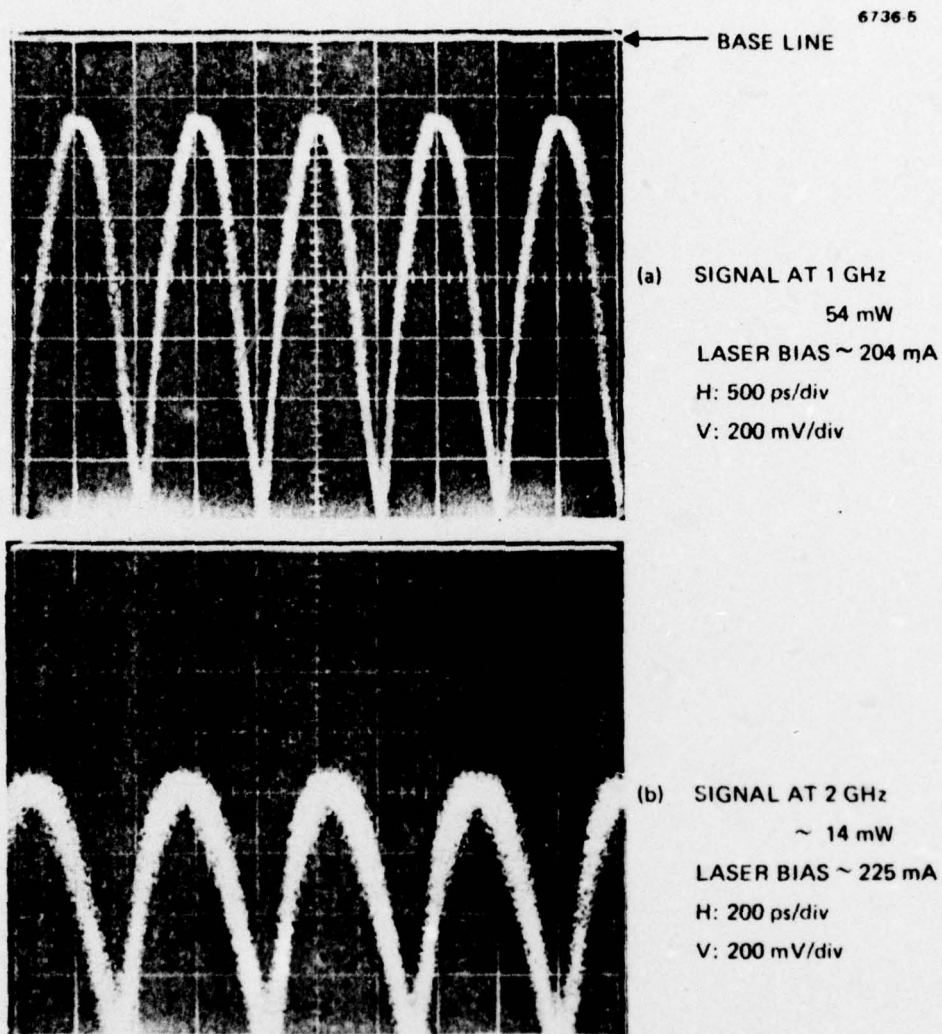
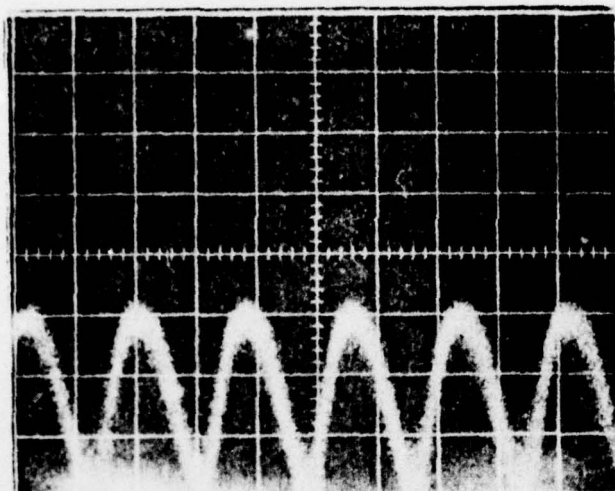
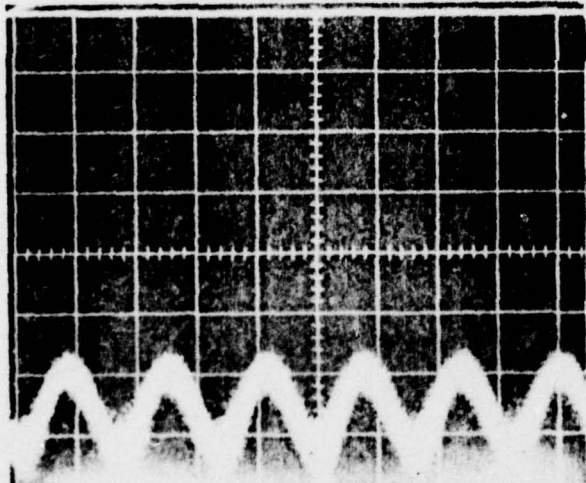

Figure 4. Pictures of modulated injection laser output.

6736-6



(c) SIGNAL AT 2.75 GHz
~ 8 mW
LASER BIAS ~ 237 mA
H: 200 ps/div
V: 200 mV/div



(d) SIGNAL AT 3 GHz
~ 8 mW
LASER BIAS ~ 225 mA
H: 200 ps/div
V: 200 mV/div

Figure 4. Continued.

6736-7

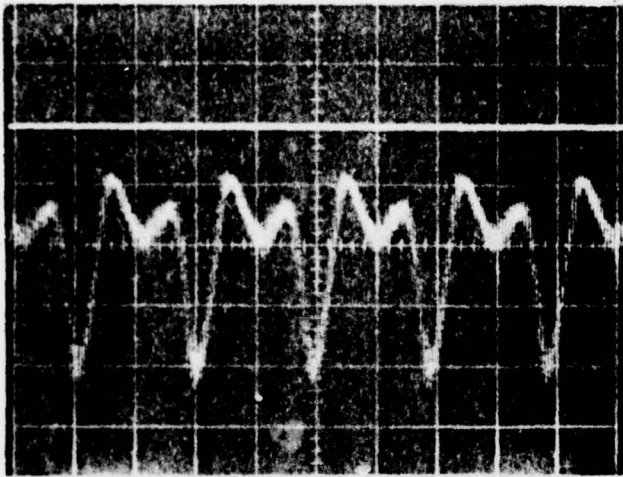

(e) SIGNAL AT 1 GHz
18 mW
LASER BIAS ~ 190 mA
H: 1 ns/div
V: 200 mV/div

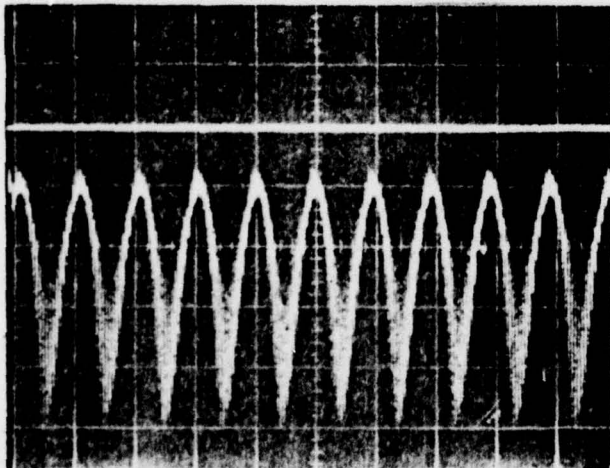

(f) SIGNAL AT 1 GHz
53 mW
LASER BIAS ~ 190 mA
H: 1 ns/div
V: 200 mV/div

Figure 4. Continued.

67368

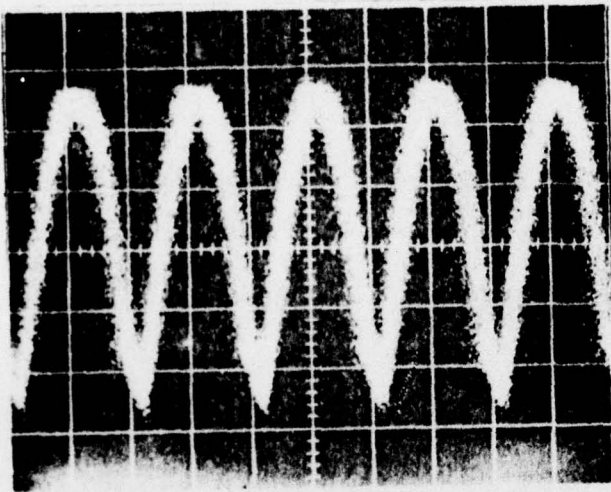

(g) SIGNAL AT 2 GHz
14 mW
LASER BIAS ~ 206 mA
H: 500 ps/div
V: 200 mV/div

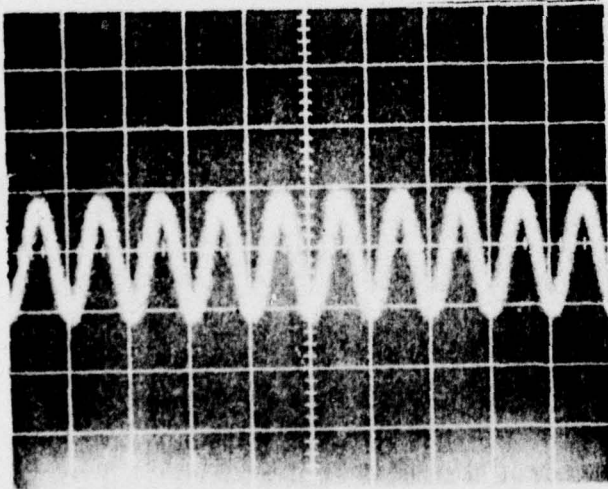

(h) SIGNAL AT 2 GHz
~ 14 mW
LASER BIAS ~ 225 mA
H: 500 ps/div
V: 200 mV/div

Figure 4. Continued.

206 to 225 mA and the laser output was modulated at 1 GHz in one case and 2 GHz in the other.

It was also observed that the laser output had amplitude fluctuations at certain bias current levels. This amplitude noise was found to occupy a spectrum range larger than 500 MHz and was believed to be caused by multimode nature of the laser.² The results shown in Figures 4(e) and 4(g) are essentially the excitation of these self-induced pulsations of the laser by the applied signal at their second harmonics.

Since our goal is to achieve modulation at highest possible frequency and highest possible depth, the multimode laser is not suitable for this purpose because of its nonlinearity as well as intermode couplings. However, there are situations where one might want to take advantage of its multimode property. One such possibly is the second-order mode locking as briefly described in Section 2.

Recently, a channeled substrate planar structure AlGaAs injection laser³ which oscillates at single transverse as well as longitudinal modes was lent to us by Professor A. Yariv of Caltech. This laser has a passive guiding mechanism built in by growing double heterostructure layers on a grooved substrate. It operates stably in the lowest order transverse mode and provides an output power as high as 10 mW per facet under cw operation. Figure 5 shows a plot of its dc characteristics. The threshold current is about 50 mA, and the output power is linearly proportional to the drive current above threshold. We have modulated this laser with a circuit similar to the one sketched in Figure 3. The modulated outputs are shown in Figure 6. In Figure 6(a) the input signal was 8 mW at 3 GHz and the laser was biased at $1.4 I_{th}$. In Figure 6(b) the frequency of the signal was increased to 3.4 GHz and substantial modulation in the laser output was detected. At this frequency we believe that the weakness of the detected signal is due mainly to the amplifier cutoff which means this laser should be able to be modulated at even higher frequencies. Currently, we are looking into better ways of detecting optical signal modulated at beyond 3 GHz.

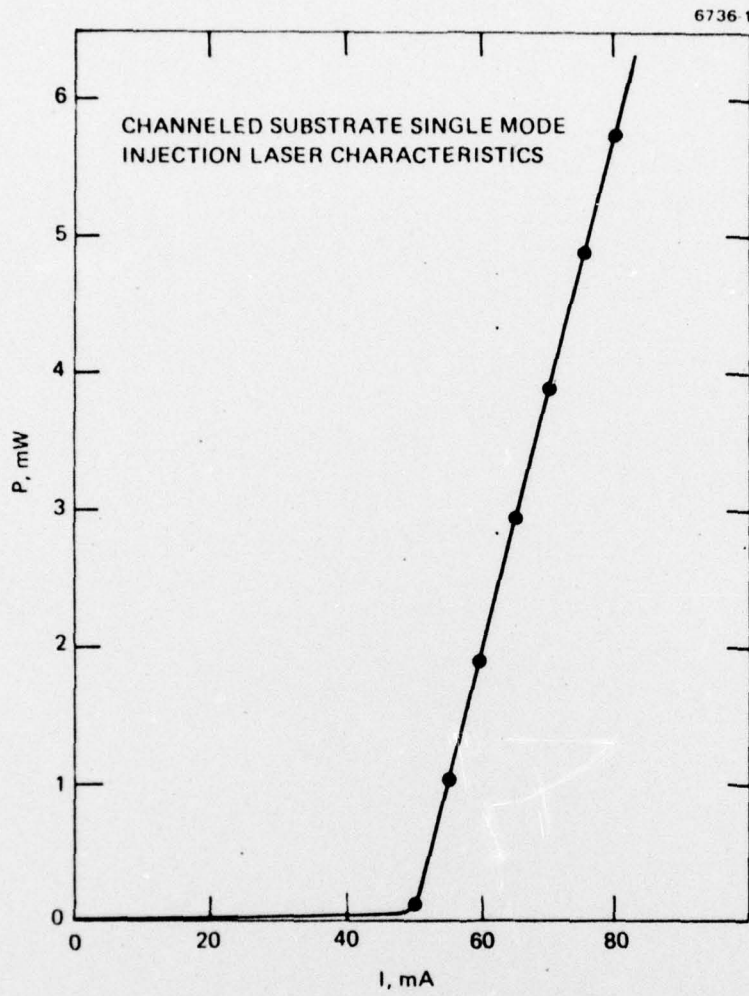
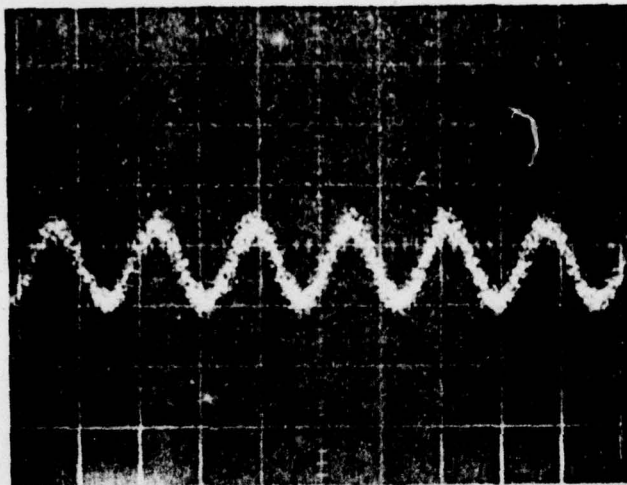
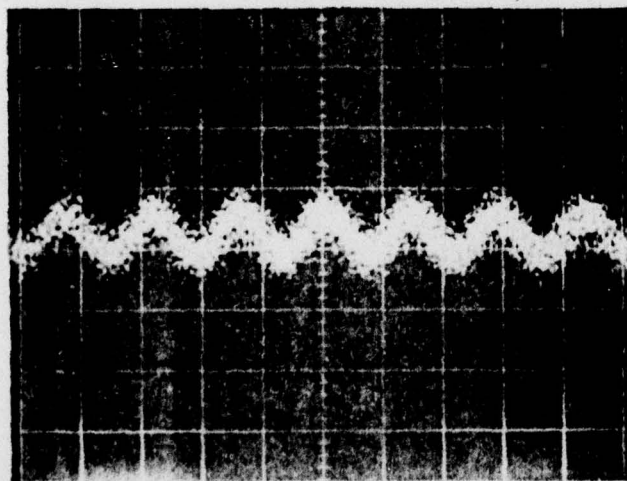

Figure 5. Channeled substrate single mode injection laser characteristics.



(a) SIGNAL AT 3 GHz \sim 8 mW
LASER BIAS 70 mA
H: 200 ps/div



(b) SIGNAL AT 3.4 GHz \sim 6 mW
LASER BIAS 70 mA
H: 200 ps/div

Figure 6. Microwave modulated outputs of channeled substrate injection laser.

One interesting aspect of this single-mode laser is that its output power versus current curve is extremely linear. Thus a small modulation current signal can be transformed into optical signal with very little distortion. As shown in Figure 7(a) the input sinusoidal electrical signal at 1 GHz has a second harmonic content of -54 dB. After feeding into the single-mode laser the optical output detected is shown in 7(b) where the total distortion introduced by the laser and the detector raised the second harmonic content up to -24 dB. To see how this analog signal behaves in a single-mode fiber we simply butt-coupled the laser output to a single-mode optical fiber 1 km long and the output is detected by the same detector and displayed in Figure 7(c).

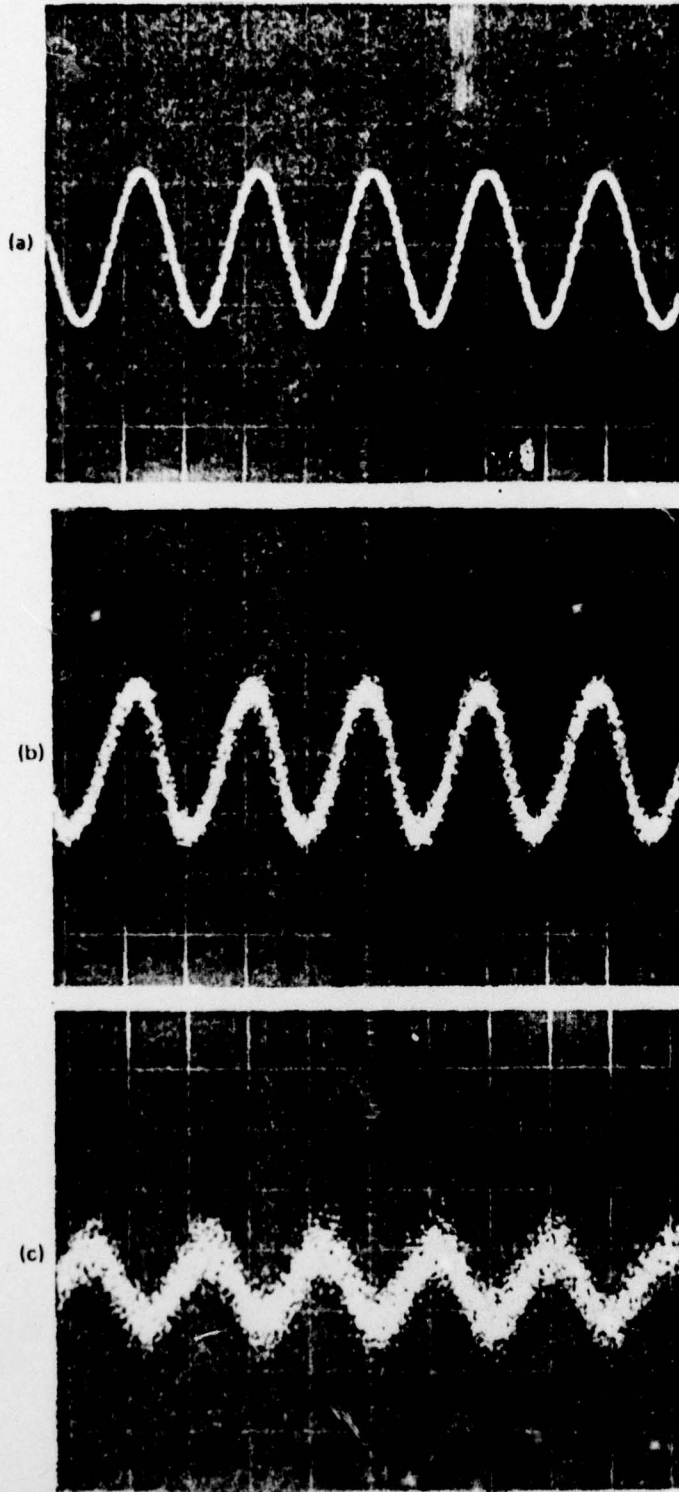

Figure 7. Direct amplitude modulation of a single mode injection laser at 1 GHz with negligible distortion.

SECTION 4

SUMMARY OF OPTICAL INJECTION LOCKING EXPERIMENT AND DESIGN OF GaAs FET OSCILLATOR

In this section we first summarize the optical injecting locking experiment that we have accomplished so far and then describe the present efforts on designing a GaAs FET oscillator.

To demonstrate the feasibility of an optical-injection locking scheme, we carried out experiments using silicon transistor oscillators. Several oscillator circuits were constructed with both low frequency and rf transistors. The metal cap of the transistors was partially removed so that the chips were accessible for illumination. The optical clocking signal was generated by direct current modulation of a cw GaAlAs injection laser ($\sim 8200 \text{ \AA}$).

The effect of illumination on the characteristics of transistors was studied first. Figure 8(a) shows the collector current versus collector voltage curves of one particular transistor (2N 5108) for various base currents. There was no optical illumination in this case. In Figure 8(b) a cw optical power of $\sim 0.3 \text{ mW}$ from a GaAlAs laser was focused onto the chip. This generated an equivalent base current of about 10 \mu A as evident by comparing Figures 8(a) and 8(b). For a transistor in the oscillator circuit, the operating point was determined by the biasing voltages. However, optical illumination can generate equivalent base current, hence effectively varying the operating point. Another effect of illumination is the modification of transistor base resistance and collector barrier capacitance caused by additional carriers generated. Thus a transistor oscillator under optical illumination will experience variation in both its output voltage amplitude and frequency.

A simple way of examining injection-locking phenomena is depicted in Figure 9. The modulated laser output is focused onto the transistor chip. The oscillator output goes to one of the vertical inputs (V_1) of an oscilloscope. A reference signal from the rf generator that modulated the laser goes to the time trigger and the second vertical input (V_2)

(a) WITHOUT ILLUMINATION

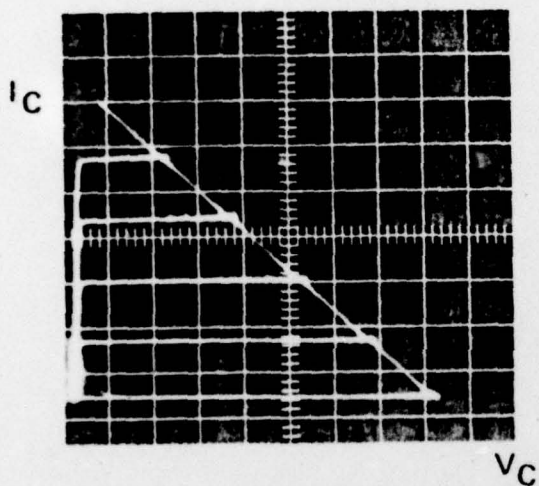

(b) WITH ILLUMINATION

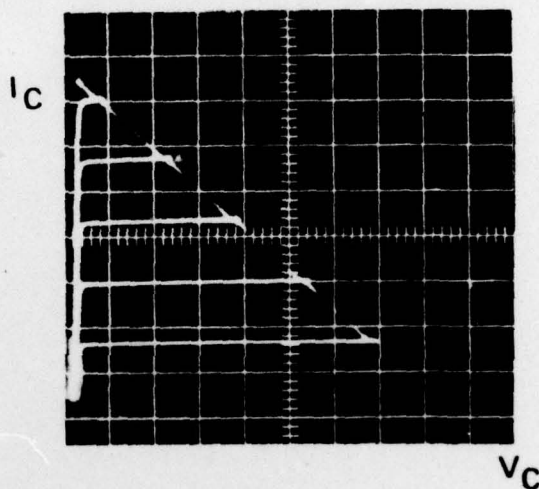

HORIZONTAL SCALE: 1 V/div
 VERTICAL SCALE: 0.2 mA/div
 BASE CURRENT: 0.01 mA/STEP

OPTICAL POWER: 0.29 mW

Figure 8. I_C versus V_C characteristics curves of an rf transistor (2N5108); (a) without illumination (b) with illumination.

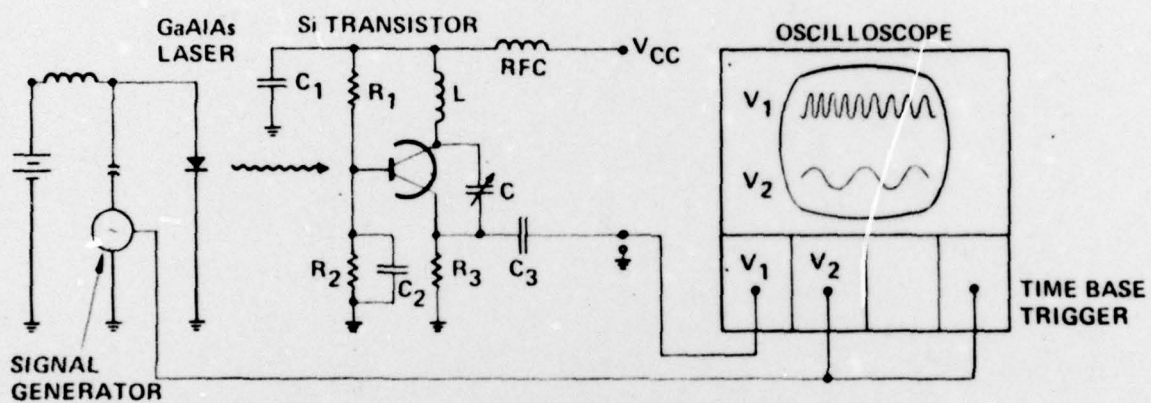

Figure 9. Schematic of the experimental setup for optical injection locking experiment.

of the same scope. Ordinarily, there is no definite phase relation between the rf generator output and the transistor oscillator output so that V_1 will not show up as a still display on the scope. However, if phase locking between the transistor oscillator and the rf generator takes place, a stationary display results.

Typical results of optical-injection locking is shown in Figure 10 where the upper trace in each picture is the transistor oscillator output signal and the lower trace is the rf generator output. Figure 10(a) is for the case when the laser beam is blocked so that no correlation exists between the two signals. In Figure 10(b) the shutter is removed; optical-injection locking takes place and a still display of the oscillator was running at 330 MHz and the rf generator put out a signal at 110 MHz. Thus optical-injection locking, as in the case of conventional-injection locking, can take place not only at the fundamental frequencies, but also at various subharmonics, and the locking range decreases as the frequency ratio increases.

The measured locking range and locking gain for our transistor oscillators are relatively low, and the reasons are two-fold: (1) the inefficient laser modulation, and (2) the non-optimum device structure. At low frequencies the transistors are designed so that the chip area is large and the spacing between emitter and base electrodes is large. Thus sufficient light can be absorbed by the semiconductor. However, for rf transistors an interdigital type of electrode is used; this leaves little area for absorbing optical energy. We believe that one can design a device that is optimized to interact with optical signal and obtain a much better result.

As we described earlier, a dc optical illumination is equivalent to having additional base bias current. It is conceivable that one can adjust the transistor bias voltage so that the circuit is slightly below threshold of oscillation, and will oscillate only when there is illumination. This is possible in our setup because there is always a dc component in the modulated laser output. Thus we can control a transistor to turn it on and off and simultaneously phase lock its output. An

(a) WITHOUT ILLUMINATION

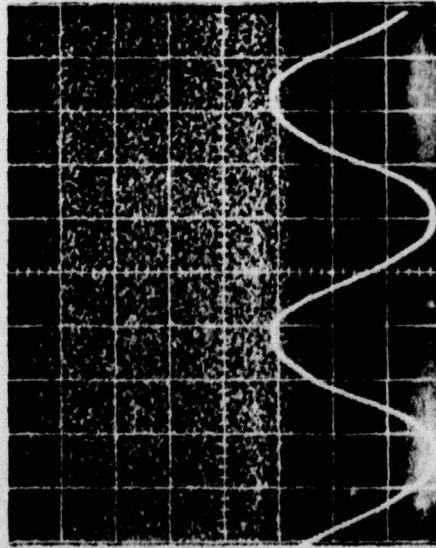

(b) WITH ILLUMINATION

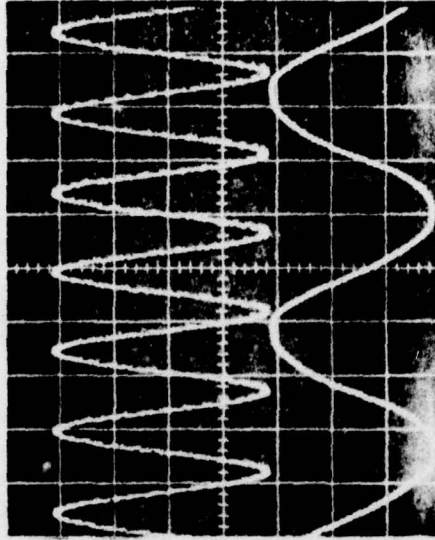

UPPER TRACE: TRANSISTOR OSCILLATOR OUTPUT (330 MHz)

LOWER TRACE: SIGNAL GENERATOR OUTPUT (110 MHz)

HORIZONTAL SCALE: 2 nsec/div

Figure 10. Scope traces of optical injection locking of silicon transistor oscillator; (a) without illumination (b) with illumination.

example of such action is shown in Figure 11. Here a transistor oscillator of frequency 1.85 GHz was switched on and phase locked by a laser output modulated at only 98 MHz.

As a continuing effort of the study of optical-injection locking we are currently designing a GaAs FET oscillator to be used in the next quarter. The GaAs FET chips are fabricated by Hughes Research Laboratories under the low-noise GaAs FET project. The channel of these FETs was formed by ion implantation of Si into Cr-doped substrates at room temperature. At 10 GHz the device has a gain of 9.2 dB and a noise figure of 2.4 dB.

The FETs were mounted in a microstrip carrier for ease of handling and measurement. A Hewlett-Packard network analyzer was used over the 4 GHz to 12 GHz range to characterize the chip with the carrier in terms of S parameters. We then repeat the measurement using a microstrip through line in place of the chip carrier. The information was then fed into the computer where a computer program separated the S parameters of the chip from the carrier.

Although the FET oscillator generally operates in the large signal mode, it has been shown^{4,5} that the only nonlinear property that needs to be considered in oscillator design is the dependence of forward gain on signal level. All the other important characteristics can be derived from the small-signal S parameter measurement described above. This makes the design work simpler. The next step is to design the input and output matching network for maximum gain⁶ and to design a proper feedback circuit. We expect this work to be completed during the next quarter and to proceed with the optical injection locking experiment.

(a) WITHOUT ILLUMINATION

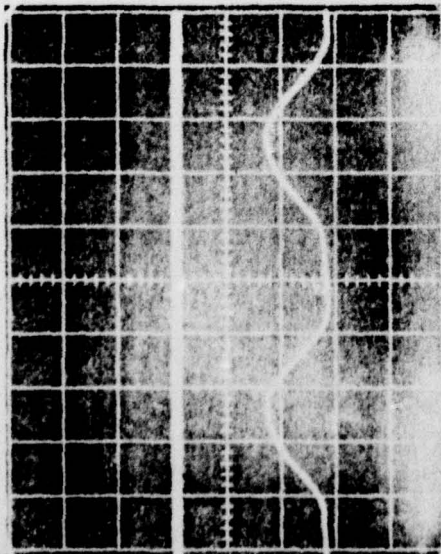

(b) WITH ILLUMINATION

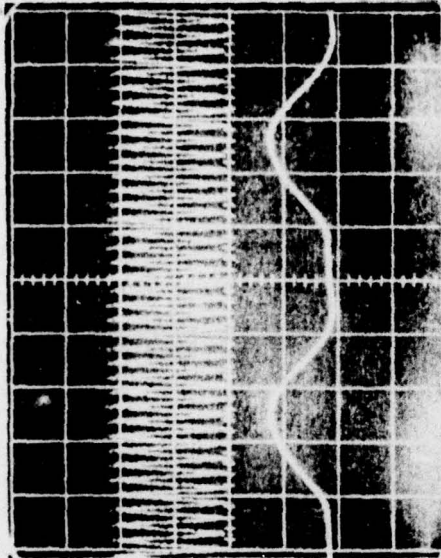

UPPER TRACE: TRANSISTOR OSCILLATOR OUTPUT (1.85 GHz)

LOWER TRACE: SIGNAL GENERATOR OUTPUT (98 MHz)

HORIZONTAL SCALE: 2 nsec/div

Figure 11. Scope traces of simultaneous optical switching and injection locking of transistor oscillator; (a) without illumination zero oscillator output, (b) with illumination, oscillator switched on and phase locked.

SECTION 5
PLANS FOR NEXT QUARTER

In the next quarter we will investigate the possibility of using second-order mode locking as an efficient way of injection laser modulation. Experiments will be carried out to verify the calculations presented in Section 2. Schemes for detecting optical signals modulated at frequencies above 3 GHz will be studied so that the upper frequency limit in laser modulation can be determined accurately. For example, we will determine whether a scanning Fabry-Perot is suitable for side band detection, whether an avalanche photodiode with a narrow band amplifier can be used for high speed narrow band detection, etc.

Theoretical study of IMPATT diode and GaAs FET under optical illumination will be completed during the next quarter to obtain a better understanding of the interaction process which will be helpful in subsequent experiments. The design and construction of an X-band GaAs FET oscillator will be finished and the characterization of its optical injection locking property will be carried out.

SECTION 6

SUMMARY

We have performed theoretical and experimental studies of direct current modulation of semiconductor injection lasers. In the small signal approximation we found that the maximum usable frequency of modulation was limited to 10 GHz. Experimentally, we have demonstrated modulation of a single-mode laser up to 3.4 GHz. We are currently limited by our detection system.

Optical-injection locking experiments at low frequencies (<2 GHz) were carried out. Injection locking was observed not only at fundamental frequencies but also at various subharmonics with less tolerance in frequency deviation. It is possible to achieve switching and locking simultaneously in these oscillators. The design and construction of an X-band GaAs FET oscillator is under way.

REFERENCES

1. K. Konnerth and C. Lanza, Appl. Phys. Lett. 4, 120 (1964).
2. T.L. Paoli and J.E. Ripper, Appl. Phys. Lett. 15, 105 (1969)
3. K. Aiki, M. Nakamura, T. Kuroda, and J. Umeda, Appl. Phys. Lett. 30, 649 (1977).
4. M. Maeda, S. Takahashi, and H. Kodera, Proc. IEEE 63, 320 (1975).
5. R.A. Pucel, R. Bera, and D. Masse, Electron. Lett. 11, 219 (1975).
6. "S Parameter Design" HP application note 154.