

AD-A050 999

GENERAL AMERICAN TRANSPORTATION CORP NILES ILL GENER--ETC F/G 14/2
NONDESTRUCTIVE INSPECTION OF SHELTER PANELS: MINIATURIZED NONDE--ETC(U)
JUL 77 M J SANTORO F33615-76-C-5278

UNCLASSIFIED

CEEDO-TR-77-47

NL

| OF |
AD
A050 999

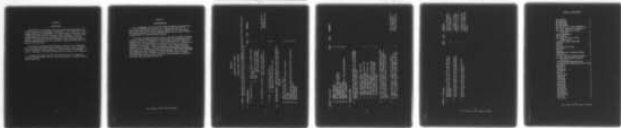

END
DATE
FILMED
4-78
DDC

AD A 050999

AD No. 1000 FILE COPY



CEEDO



CEEDO-TR-77-47

2
B.S.

NONDESTRUCTIVE INSPECTION OF SHELTER PANELS: MINIATURIZED NONDESTRUCTIVE INSPECTION TESTER MODEL

GENERAL AMERICAN TRANSPORTATION CORP. (GATX)
GENERAL AMERICAN RESEARCH DIVISION
7449 N. NATCHEZ AVE. NILES IL 60648

JULY 1977

FINAL REPORT FOR PERIOD MARCH 1976 TO JUNE 1977

Approved for public release; distribution unlimited

CIVIL AND ENVIRONMENTAL ENGINEERING DEVELOPMENT OFFICE

(AIR FORCE SYSTEMS COMMAND)
TYNDALL AIR FORCE BASE
FLORIDA 32403

DDC
RECEIVED
MAR 8 1978
B

REPORT DOCUMENTATION PAGE		READ INSTRUCTIONS BEFORE COMPLETING FORM
1. REPORT NUMBER CEEDG-TR-77-47	2. GOVT ACCESSION NO.	3. RECIPIENT'S CATALOG NUMBER 9 (rept.)
4. TITLE (and Subtitle) NONDESTRUCTIVE INSPECTION OF SHELTER PANELS: MINIATURIZED NONDESTRUCTIVE INSPECTION TESTER MODEL.	5. TYPE OF REPORT & PERIOD COVERED Final Mar 76 - Jun 77	
6. AUTHOR(s) Michael J./Santoro	7. PERFORMING ORG. REPORT NUMBER	
8. CONTRACT OR GRANT NUMBER(s) F-33615-76-C-5278 New	9. PROGRAM ELEMENT, PROJECT, TASK AREA & WORK UNIT NUMBERS 64721F/2054/2004 12 20	
10. PERFORMING ORGANIZATION NAME AND ADDRESS General American Transportation Corp. (GATX) General American Research Division 7449 N. Natchez Ave. Niles IL 60648	11. CONTROLLING OFFICE NAME AND ADDRESS Det 1 HQ ADTC Directorate of Civil Engineering Development Tyndall AFB FL 32403	
12. REPORT DATE July 1977	13. NUMBER OF PAGES 18	
14. MONITORING AGENCY NAME & ADDRESS (if different from Controlling Office) Air Force Materials Laboratory AFML/MXA Wright-Patterson AFB OH 45433 12 17p.	15. SECURITY CLASS. (of this report) UNCLASSIFIED	
15a. DECLASSIFICATION/DOWNGRADING SCHEDULE		
16. DISTRIBUTION STATEMENT (of this Report) Approved for public release; distribution unlimited.		
17. DISTRIBUTION STATEMENT (of the abstract entered in Block 20, if different from Report) B		
18. SUPPLEMENTARY NOTES Available in DDC		
19. KEY WORDS (Continue on reverse side if necessary and identify by block number) nondestructive inspection debonds nondestructive testing delaminations sandwich panels moisture air transportable shelters field inspection		
20. ABSTRACT (Continue on reverse side if necessary and identify by block number) This report summarizes the results of an effort to develop a miniaturized model of the nondestructive inspection prototype equipment developed under Contract F-33615-71-C-1552. The details of the initial equipment development have been documented in AFCEC-TR-75-2, Jan 1975. The miniaturized model has been successfully laboratory and field tested and the results of these tests are included along with conclusions and recommendations.		

DDC
RECEIVED
MAR 8 1978
B

400 306

LB

PREFACE

This report summarizes work done from March 1976 through June 1977 by General American Transportation Corporation (GATX); General American Research Division (GARD) Niles, Illinois under contract F-33615-76-C-5278 with the Air Force Materials Laboratory (AFML), Wright-Patterson AFB, Ohio. The technical representative from AFML was Grover Hardy, AFML-MXA. The work was performed at GARD in the Electronics Systems Department by Fay K. Chin, Project Engineer, with the engineering assistance of Irvin R. Kraska and Norman F. Muelleman. The work was performed under the guidance of Michael J. Santoro, CEEDO/CN.

The author gratefully acknowledges the assistance provided by Sgt A. Landry, Air Force Civil Engineering Center, the shelter maintenance personnel at Holloman AFB NM, and shelter maintenance personnel at Ogden ALC, Hill AFB UT, for the field testing.

This report has been reviewed by the Information Officer (OI) and is releasable to the National Technical Information Service (NTIS). At NTIS, it will be available to the general public, including foreign nations.

This technical report has been reviewed and is approved for publication.

Michael J. Santoro
MICHAEL J. SANTORO
Project Engineer

G. York

G. YORK, Lt Col, USAF
Director of Civil Engineering Development

Joseph S. Pizzuto
JOSEPH S. PIZZUTO, Col, USAF, BSC
Commander

ACCESSION for		
NTIS	White Section	<input checked="" type="checkbox"/>
DDC	Buff Section	<input type="checkbox"/>
UNANNOUNCED		<input type="checkbox"/>
JUSTIFICATION _____		
BY _____		
DISTRIBUTION/AVAILABILITY CODES		
Dist.	AVAIL.	and/or SPECIAL
A		

TABLE OF CONTENTS

Section	Title	Page
I	INTRODUCTION	1
II	DEVELOPMENT OF MINIATURIZED TESTER	2
III	LABORATORY AND FIELD TESTING	6
IV	CONCLUSIONS	8
V	RECOMMENDATIONS	9
Appendix	Laboratory Test Report	10

LIST OF FIGURES

Figure	Title	Page
1	Shelter Panel Inspector	3
2	Block Diagram of Shelter Panel Inspector	4

LIST OF TABLES

Table	Title	Page
1	Shelter Panel Inspector Specifications	5

SECTION I

INTRODUCTION

Debonds and free water presence are common defects in Air Force shelters of laminated metal panel construction. Reliable and early field detection of these defects is necessary for efficient field maintenance of shelters.

Prototype equipment allowing simultaneous inspection for debonds and free water in laminated metal panels was developed under Contract F-33615-71-C-1552. The equipment uses a unique eddy sonic technique capable of detecting 1/2-inch diameter and larger debonds in foam and honeycomb core panels with 0.020 to 0.100-inch metal face-sheet thickness, and is capable of detecting a single water-filled cell in metal-to-paper honeycomb panels and 1-inch diameter by 0.020-inch thick waterfilled area in metal-to-foam panels. Inspection rates of approximately 600 square feet per hour while maintaining sensitivity to 2-inch diameter debonds was obtained by the equipment. Further details can be obtained from Technical Report AFCEC-TR-75-2.

This report describes the miniaturization of the above prototype equipment into a small, portable, rugged model, and the laboratory and field testing of this miniaturized panel inspector.

SECTION II

DEVELOPMENT OF MINIATURIZED TESTER

As a result of a previous contract, F33615-71-C-1552, prototype equipment capable of field detection of debonds and water in shelter sandwich panels was developed and tested. However, the prototype equipment was too large and too heavy for field use (about 30 by 21 by 29 inches and weighed 200 pounds with batteries and 120 pounds without batteries). A recommendation of the previous contract work was to reduce the size and weight, and to improve the operational characteristics of the prototype equipment. (Reference AFCEC-TR-75-2).

This recommendation led to the development of a miniaturized tester, which is the subject of this report. The development involved designing a tester to perform the functions of the prototype equipment using electronic solid-state components to replace bulky non-solid-state components. Printed circuit boards and integrated circuits with wire-wrap connections were used as much as possible to incorporate several functional components into one component. The size of the batteries was reduced to a smaller self contained battery.

The resulting miniaturized tester was a portable, rugged, battery or ac powered non-destructive Shelter Panel Inspector, as shown in Figure 1. It is capable of detecting debonds and water in laminated shelter panels with metal face sheets joined to foam, paper honey-comb, and balsawood cores, and may also be used to detect debonds in other metal composite structures with appropriate calibration. A unique eddy sonic technique is employed by the tester by applying a sonic signal and sensing the response with a transducer/microphone hand-held probe. (Further details on the eddy sonic technique used can be found in Technical Report AFCEC-TR-75-2). The probe is moved over the surface of the structure being checked and the response is fed back through the probe to a digital counter display for measurement and indication of the response signal, and to alarm and indicator lights as Go/No indications. A block diagram of the circuit operation is shown in Figure 2.

Table 1 lists the major specifications of the tester.

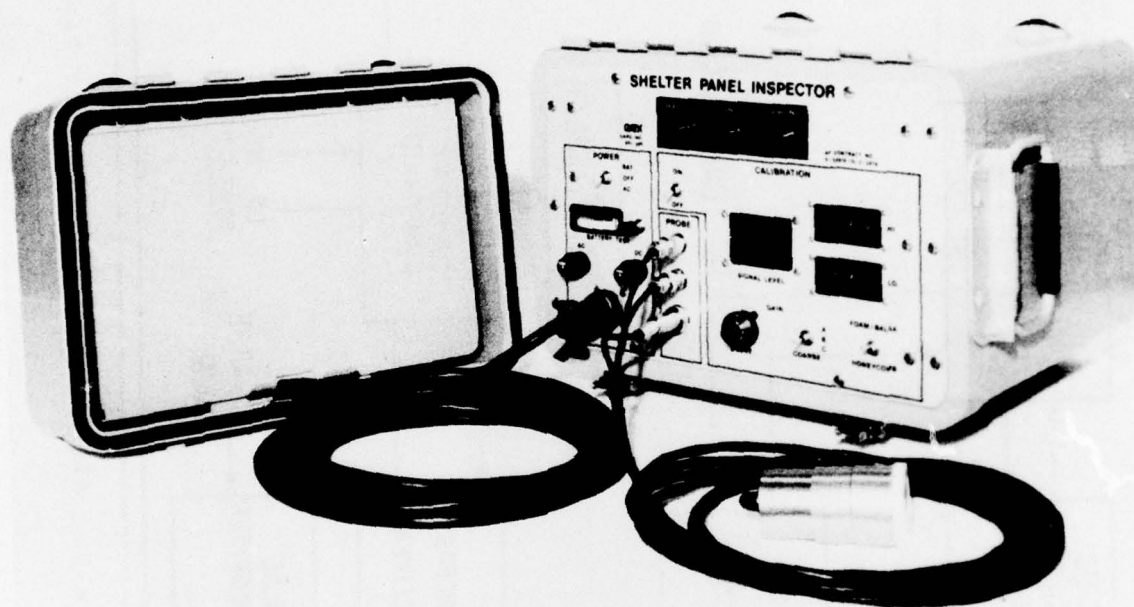

Figure 1. Shelter Panel Inspector

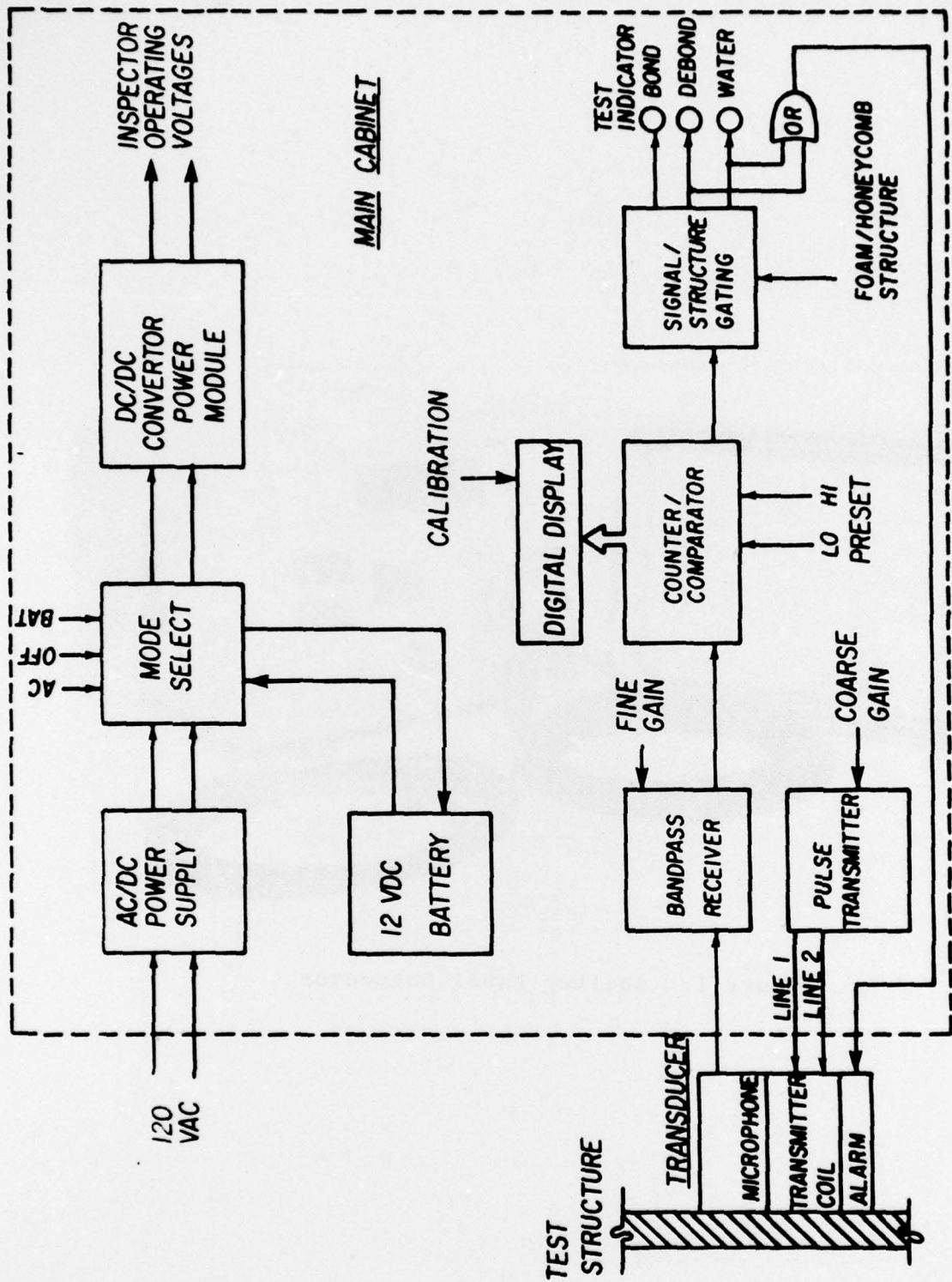

Figure 2. Block Diagram of Shelter Panel Inspector

TABLE 1. SHELTER PANEL INSPECTOR SPECIFICATIONS

1. Size: 9.0 inches long, 13.5 inches wide, and 16.25 inches deep (including cover)
2. Weight: 41 pounds including battery and all accessories with integral transport case
3. Input Voltage: (AC operation) 115 VAC \pm 10 percent, 47-63 Hz
(DC operation) 12 VDC, internal battery
4. Power Consumption: Approximately 35 watts (30 watts-display disabled)
5. Warmup Time: 5 minutes
6. Operating Environment:
 - a. Ambient temperature: 40-125°F
 - b. Humidity: 0-95 percent
 - c. Altitude: 0-10,000 ft
7. Battery Powered Duration: 4 hours (Worst case)

SECTION III

LABORATORY AND FIELD TESTING

The Shelter Panel Inspector was evaluated in the laboratory at the contractor's facility, GATX, Niles, IL and in the field at Holloman AFB, NM and at Ogden ALC, Hill AFB, UT.

Laboratory testing was successfully performed on typical sample test panels provided by the Air Force at the contractor's facility at Niles, IL. The testing verified acceptable performance in the areas described below:

1. Mechanical inspection-size, weight, packaging
2. Electronic inspection-power supply, transmitter, receiver, counter, front panel
3. Environmental inspection-temperature, humidity
4. Operating procedure inspection
5. Calibration procedure inspection

The Appendix contains the results of the laboratory testing.

Field testing was performed at Holloman AFB, NM on Bare Base Shelters and at Ogden ALC, Hill AFB, UT on Tactical Shelters used for photography reconnaissance and other purposes.

At Holloman AFB, approximately 20 shelters constructed of foam and honeycomb cores with facial sheet thickness ranging from 0.025 to 0.125 inch were inspected. Several debonds were located with the Inspector and were verified as true debonds by the manual coin tap method. There was a 100 percent correlation between debonds located by the Inspector and the coin tap method, and it was shown that the Inspector located debonds that were not normally found using the coin tap method.

No water entrapped conditions were found at Holloman AFB, but a honeycomb panel from one of the shelters was artificially seeded with water and the Inspector accurately located the water.

Environmental conditions at Holloman AFB indicated that the Inspector operated well at 50°F and 4000-foot altitude.

A Staff and a Technical Sergeant from the 4449 MOBSS were trained to use the Inspector at Holloman AFB and successfully inspected several shelters after a brief 1-hour training period.

The field tests at Ogden ALC, Hill AFB, UT were performed on several foam and honeycomb panel shelters with facial sheet thicknesses ranging from 0.040 to 0.125 inch. Several debonds were located with the Inspector and verified with the coin tap method. Again there was 100 percent correlation between the Inspector located debonds and the coin tap method located debonds, and the Inspector found debonds not normally found using the coin tap method. On one of the shelters the debonds found by the Inspector were verified by actually cutting sections out of the shelter and visually noting the debond.

Water entrapped conditions were not found at Ogden ALC, but a honeycomb panel from one of the shelters was artificially seeded with water and the Inspector accurately located the water.

Environmental conditions at Ogden ALC indicated that the Inspector operated well at 40°F and 4400-foot altitude.

The Inspector was left at Ogden ALC for 20 days and Air Force personnel at Ogden evaluated the Inspector during this time after being given a brief 1-hour training session.

Testing at Ogden ALC also indicated that the Inspector could be used in a shelter depot repair facility for testing and making repairs. The testing at Ogden also showed that the Inspector can give erroneous indications on shelters that have been previously repaired unless it is calibrated properly. Thus care must be exercised when testing panels which have previously been repaired.

SECTION IV

CONCLUSIONS

The Shelter Panel Inspector has been successfully developed and tested and meets the performance requirements. The Inspector is small, rugged, and easily transportable. It can be used in the field or in a depot repair facility to accurately detect debonds in shelter sandwich panels faster and more accurately than the present coin tap method. The Inspector can also accurately locate entrapped water in shelter sandwich panels and this provides a capability that does not exist in the field now.

On shelters that have been previously repaired, it is important that the repair method and repair material be known before attempting to use the Shelter Panel Inspector to detect debonds or entrapped water. Otherwise, erroneous indications can be given by the Inspector.

A prime item product function specification for the Inspector has been developed which can be used for procurement of future Shelter Panel Inspectors.

SECTION V

RECOMMENDATIONS

It is recommended that the Shelter Panel Inspector be procured by the shelter maintenance personnel at all bases that maintain or repair shelters, and that it be used to replace the coin tap method for locating debonds in shelter sandwich panels and be used to locate entrapped water in shelter sandwich panels.

Air Force personnel should be properly trained and become familiar with the Inspector characteristics, operations, and limitations before attempting to use the Inspector. The Air Force personnel should be familiar with the construction of the shelter panel, i.e., facial sheet thickness, hat sections, types of adhesive, etc., before using the Inspector on the panel. Also the personnel should exercise caution when using the Inspector on panels which have previously been repaired. To properly use the Inspector on repaired panels, they should determine what method was used in making the repair and what type of repair materials were used so that the Inspector can be properly calibrated for these repaired panels before use.

APPENDIX

LABORATORY TEST REPORT

SHELTER PANEL INSPECTOR

I. Scope - Demonstration and verification of the conformance of the fabricated Shelter Panel Inspection System as specified by Contract No F33615-76-C-5278.

II. Characteristics

- A. Transportability: 1. Weight 41 pounds (including cover and battery)
- 2. Size 9.0 L by 13.5 W by 16.25 D
- 3. Case: impact resistant ruggedized with carrying handles

B. Environmental Resistance: sealed cover and weather proof control/display panel

- C. Power: 1. AC 35 watts at 115 VAC
- 2. Battery 4 hours at 12 VDC
- 3. Charge Time 16 hours at 115 VAC

III. Functional Tests - Operator/Inspection controls and indicators shall be verified for proper operation as designed.

- A. BAT/OFF/AC Power Control
- B. Battery test switch and condition indicator
- C. AC Fuse
- D. DC Fuse
- E. Probe interface (Transmitter/Receiver/Alarm connectors)
- F. Calibration switch
- G. Digital display
- H. BOND indicator

	<u>Pass</u>	<u>Fail</u>	<u>Comments</u>
X			
X			
X			
X			All controls and displays inspected for seals
X			
X			
X			
X			
X			
X			
X			
X			
X			

APPENDIX (continued)

	<u>Pass</u>	<u>Fail</u>	<u>Comments</u>
I. DEBOND indicator	X		
J. WATER indicator	X		
K. HI calibration limit selector	X		
L. LO calibration limit selector	X		
M. FINE GAIN control	X		
N. COARSE GAIN control	X		
O. CORE Material selector (Foam Balsa/Honeycomb)	X		
P. ALARM - transducer	X		

IV. Operating Tests

A. Using calibration panels provided (i.e., with bonded, debonded, and water included areas) on both honeycomb and foam/balsa cores verify that:

1. Bond indicator on panel lights with probe over bonded area. X
2. Debond indicator on panel lights with probe over debonded areas. X
3. Water indicator on panel lights with probe over water area. X
4. Probe alarm indicator is on when probe is either over debond or water areas. X
5. System inspects accurately with panel horizontal and vertical. X

B. On large (4 by 8 foot) panel, using calibration levels set in A (or reset levels if panel sample is different from calibration panels), scanning should show no random unexplained system alarms (or light flashing). X

C. On large panel (4 by 8 foot) which has a defect of about 2-3 inches, perform a total hand scan at a speed slow enough to alarm on the defect, and calculate the effective square footage scanned per hour. X

Scan rate calculated to effective square footage of 600 sq ft per hour.

APPENDIX (continued)

	<u>Pass</u>	<u>Fail</u>	<u>Comments</u>
D. Operate unit at 40°F and 125°F and show that water/debond/bond detection can be accurately performed.	X		Foam and Honeycomb core panels successfully inspected.
E. Verify typical inspection system operational time available under battery powered operation	X		3 discharge cycles performed with same results of 4.5 hour.
F. Verify battery charge time associated with typical inspection system operation.	X		3 charge cycles performed with same results of 16 hours per charge.

INITIAL DISTRIBUTION

HQ USAF/PRE	1
HQ USAF/RDPQ	1
HQ USAF/PREC	1
HQ USAF/PREEO	1
Nav Facilities Engrg Comd/Code 03	1
Nav Const Battalion Ctr/Code 15	2
Nav Const Battalion Ctr/Civ	
Engrg Lab	1
HQ DA (DAEN-RDM)	1
USA MERADCOM	1
USA (CERL) DA Const Engrg	
Research Lab	1
HQ Marine Corps (Code LME)	1
DDC/TCA	2
ASD/DE	1
AUL (AUL-LSE-70-239)	1
AFSC/DE	1
AFSC/DL	1
M&SD/USMC Dev & Education Comd	1
AFATL/DLODL	2
US Army Mobility Equip R&D Comd	1
US Army Cold Regions Research	
Engrg Lab	1
USAE Waterways Experiment Sta	1
US Army Natick Research and Dev Comd	1
HQ MAC/DE	1
AFIT/DE	1
USAFSS/DEE	1
HQ TAC/DE	1
ESD/DE	1
HQ AFSC/SDA	1
CEEDO/PRT	1
CEEDO/CNE	5
OO-ALC/MM	1
SA-ALC/MM	1
SM-ALC/MM	1
WR-ALC/MM	1
OC-ALC/MM	1
HQ AFLC/MM	1
HQ SAC/DE	1
HQ PACAF/DE	1
HQ USAFE/DE	1
RADC/TUG	1
HQ AFCS/DE	1