

AD A 051165

January, 1978

ESL-R-797

ARPA Contract ONR/N00014-75-C-1183

12

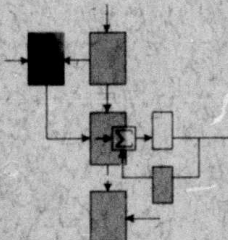

BUFFERING AND FLOW CONTROL IN MESSAGE SWITCHED COMMUNICATION NETWORKS

Eberhard Frank Wunderlich

DDC
 RECEIVED
 MAR 10 1978
 F

DISTRIBUTION STATEMENT A
 Approved for public release.
 Distribution Unlimited

Electronic Systems Laboratory

MASSACHUSETTS INSTITUTE OF TECHNOLOGY, CAMBRIDGE, MASSACHUSETTS 02139

Department of Electrical Engineering and Computer Science

AD No. []
DDC FILE COPY

REPORT DOCUMENTATION PAGE		READ INSTRUCTIONS BEFORE COMPLETING FORM
1. REPORT NUMBER 6	2. GOVT ACCESSION NO. 19	3. REPORTING ORGANIZATION NUMBER Doctoral Thesis
4. TITLE (and Subtitle) BUFFERING AND FLOW CONTROL IN MESSAGE SWITCHED COMMUNICATION NETWORKS		5. AUTHOR(s) 10 Eberhard Frank / Wunderlich
6. PERFORMING ORGANIZATION NAME AND ADDRESS Massachusetts Institute of Technology Electronic Systems Laboratory Cambridge, Massachusetts 02139		7. PERFORMING ORGANIZATION REPORT NUMBER ESL-R-797
8. CONTROLLING OFFICE NAME AND ADDRESS Defense Advanced Research Projects Agency 1400 Wilson Boulevard Arlington, Virginia 22209		8. CONTRACT OR GRANT NUMBER(s) ARPA Order No. 3045/5-7-75 15 N00014-75-C-1183 ARPA 181dCF-3045
9. MONITORING AGENCY NAME & ADDRESS (if different from Controlling Office) Office of Naval Research Information Systems Program Code 437 Arlington, Virginia 22217		10. PROGRAM ELEMENT (PROJECT, TASK AREA & WORK UNIT NUMBERS) Programming Code No. 5T10 ONR Identifying No. 049-383
11. DISTRIBUTION STATEMENT (of this Report) Approved for public release; distribution unlimited.		11. REPORT DATE January 1978
12. DISTRIBUTION STATEMENT (of the abstract entered in Block 20, if different from Report)		12. NUMBER OF PAGES 220
13. SUPPLEMENTARY NOTES		13. SECURITY CLASS. (of this report) UNCLASSIFIED
14. KEY WORDS (Continue on reverse side if necessary and identify by block number) Buffering Communication Networks Flow Control Message Switched Networks Queueing Theory		14. DECLASSIFICATION/DOWNGRADING SCHEDULE
15. ABSTRACT (Continue on reverse side if necessary and identify by block number) This mathematical study of buffering and flow control is based on a gradual input queueing model. The gradual input model has been used previously to study data multiplexors. Here it is extended to an entire message switched communication network. A probability of buffer overflow analysis is developed and used to determine buffer requirements. A delay analysis is also developed. The		

DDC
RECEIVED
MAR 10 1978
F

127200

[Handwritten signature]

20. Continued.

results obtained using the gradual input queue are compared to the commonly used M/M/1 queue model for message switched networks. The gradual input model allows one to observe several effects due to a finite number of finite rate traffic sources in such networks that cannot be observed using the M/M/1 model.

Flow control is studied in tree concentration structures. The flow control assures that buffer overflows will occur only at source nodes, not in the interior of the tree. The problem of finding the buffer allocation that minimizes the probability of buffer overflow in such a tree is studied. It is shown that in certain cases it is optimal to place all buffers at source nodes. This is, however, not always so and insight into this is given by example.

Determining the performance of a tree structure in which flow control is being used is a difficult analytic problem. An approximate analysis based on a first passage time theorem for Markov chains is therefore developed for an example. The approximate analysis is verified by simulation.

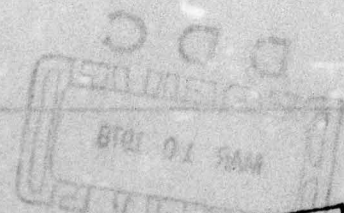

ACCESSION for		<input checked="" type="checkbox"/>
NTIS	B I Section	<input type="checkbox"/>
DDC		<input type="checkbox"/>
UNANNOUNCED		
JUSTIFICATION		
BY		
DISTRIBUTION/AVAILABILITY CODES		
Dist.		SPECIAL
A		

January, 1978

Report ESL-R-797

**BUFFERING AND FLOW CONTROL IN MESSAGE SWITCHED
COMMUNICATION NETWORKS**

by

Eberhard Frank Wunderlich

This report is based on the unaltered thesis of Eberhard Frank Wunderlich submitted in partial fulfillment of the requirements for the degree of Doctor of Philosophy at the Massachusetts Institute of Technology in January, 1978. This research was conducted at the Decision and Control Sciences Group of the M.I.T. Electronic Systems Laboratory, with partial support extended by the Advanced Research Projects Agency under Contract ONR/N00014-75-C-1183.

**Electronic Systems Laboratory
Department of Electrical Engineering
and Computer Science
Massachusetts Institute of Technology
Cambridge, Massachusetts 02139**

**BUFFERING AND FLOW CONTROL IN MESSAGE SWITCHED
COMMUNICATION NETWORKS**

by

EBERHARD FRANK WUNDERLICH

**B.S.E.E., University of Nebraska-Lincoln
(1974)**

**S.M.E.E., Massachusetts Institute of Technology
(1975)**

**SUBMITTED IN PARTIAL FULFILLMENT
OF THE REQUIREMENTS FOR THE
DEGREE OF**

DOCTOR OF PHILOSOPHY

at the

MASSACHUSETTS INSTITUTE OF TECHNOLOGY

(January 1978)

**Signature of Author.....
Department of Electrical Engineering and Computer Science
January 11, 1978**

**Certified by.....
Thesis Supervisor**

**Accepted by.....
Chairman, Department Committee**

**BUFFERING AND FLOW CONTROL IN MESSAGE
SWITCHED COMMUNICATION NETWORKS**

by

EBERHARD FRANK WUNDERLICH

Submitted to the Department of Electrical Engineering and Computer Science on January 11, 1978 in partial fulfillment of the requirements for the Degree of Doctor of Philosophy.

ABSTRACT

This mathematical study of buffering and flow control is based on a gradual input queueing model. The gradual input model has been used previously to study data multiplexors. Here it is extended to an entire message switched communication network.

A probability of buffer overflow analysis is developed and used to determine buffer requirements. A delay analysis is also developed. The results obtained using the gradual input queue are compared to the commonly used M/M/1 queue model for message switched networks. The gradual input model allows one to observe several effects due to a finite number of finite rate traffic sources in such networks that cannot be observed using the M/M/1 model.

Flow control is studied in tree concentration structures. The flow control assures that buffer overflows will occur only at source nodes, not in the interior of the tree. The problem of finding the buffer allocation that minimizes the probability of buffer overflow in such a tree is studied. It is shown that in certain cases it is optimal to place all buffers at source nodes. This is, however, not always so and insight into this is given by example.

Determining the performance of a tree structure in which flow control is being used is a difficult analytic problem. An approximate analysis based on a first passage time theorem for Markov chains is therefore developed for an example. The approximate analysis is verified by simulation.

Thesis Supervisor: John M. Wozencraft
Title: Professor of Electrical Engineering

ACKNOWLEDGEMENTS

I gratefully acknowledge the assistance of my thesis supervisor, Professor John M. Wozencraft. His guidance and advice have been most helpful during the course of my thesis research and throughout my graduate studies at M.I.T. It has been a pleasure to work with him.

I am thankful to my thesis readers, Professor Robert G. Gallager and Professor Nils R. Sandell, Jr. for their comments. Several of their suggestions led directly to results contained in this thesis.

I would also like to acknowledge assistance from Dr. Pierre Humblet, Dr. Joe Defenderfer, Dr. Ronald Pannatoni and Dr. Loren Platzman. They reviewed many of my ideas and contributed to them. Dr. Humblet was especially helpful in adding mathematical insight to this study.

The thesis was skillfully typed by Ms. Sandy Margeson. This study was done with support from a Vinton Hayes Fellowship and by the Advanced Research Projects Agency under Contract ONR/N00014-75-C-1183.

I would like to thank my parents for their support and encouragement throughout my student years. Finally, I thank my dear Shahla who has filled my life with joy while I was completing this thesis.

TABLE OF CONTENTS .

	<u>Page</u>
TITLE PAGE.	1
ABSTRACT.	2
ACKNOWLEDGEMENTS.	3
TABLE OF CONTENTS	4
CHAPTER I - INTRODUCTION.	6
1.1 Description of the Problem.	6
1.2 Previous Studies of Buffering and Flow Control.	12
1.3 Summary of Results.	19
CHAPTER II- THE ANALYSIS OF A SINGLE GRADUAL INPUT QUEUE	23
2.1 The Basic Gradual Input Queue Model	23
2.1.1 Definitions and previous results	23
2.1.2 Equivalent M/G/1 queue service time analysis	32
2.1.3 Bounds for the expected delay per bit	45
2.2 The Gradual Input Queue With a Finite Buffer	49
2.2.1 Probability of buffer overflow in a busy period.	49
2.2.2 Examples of the bounds on Pr(overflow).	54
2.2.3 A per unit time overflow measure	63
2.2.4 Other overflow measures	72
2.3 Comparison of the Gradual Input Queue and the M/M/1 Queue	78
CHAPTER III-NETWORKS OF GRADUAL INPUT QUEUES.	86
3.1 Approximations for the Analysis of a General Network.	86
3.1.1 Traffic streams in general networks.	86

3.1.2	Expected on-time for a switched busy period.	95
3.1.3	Determining the mean traffic parameters in a general network	98
3.1.4	Simulation verification	108
3.2	Examples of General Networks.	115
3.3	The Static Routing Problem	129
CHAPTER IV-	FLOW CONTROL IN TREE CONCENTRATION STRUCTURES.	137
4.1	Determining the Optimum Buffer Allocation in a Tree Concentration Structure	138
4.1.1	The optimality of buffering only at source nodes.	138
4.1.2	Flow control when all buffers are at source nodes	154
4.1.3	The effect of gradual inputs.	157
4.2	The Queueing Analysis of a Concentration Tree.	171
4.2.1	An approximate analysis of a two level tree.	171
4.2.2	An example and simulation verification.	186
CHAPTER V -	CONCLUSION AND SUGGESTIONS FOR FURTHER RESEARCH.	189
5.1	Conclusion.	189
5.2	Suggestions for Further Research.	193
APPENDIX A-	RESULTS FOR THE GRADUAL INPUT QUEUE WITH NONIDENTICAL INPUT CHANNELS.	195
APPENDIX B-	A LIMIT THEOREM FOR FIRST PASSAGE TIME DISTRIBUTIONS.	199
REFERENCES.	213

CHAPTER I - INTRODUCTION

1.1 Description of the Problem

Message switched communication networks are moving quickly into prominence as effective networks for data communication. Much of the current interest in message switched networks has resulted from the experience of the Advanced Research Projects Agency Network (ARPANET). ARPANET demonstrated that a message switched network in which messages are sent as one or more packets can be an appropriate design choice for providing communications for computers [RBRTS 70, KAHN 72]. There are also a number of other packet switched networks which currently exist or are under development. These include the Cyclade Network [POUZ 74], the Transpac Network [DANET 76], the commercial network Telenet and the military network Autodin [ROSN 73].

An important characteristic of message switched networks for data communication is that they can contain buffers. Buffers allow the network to accept temporarily traffic from sources at a rate greater than the rate at which it is being delivered to the destinations. Since buffers have finite capacity, message switched networks require flow control mechanisms to control the traffic sources in order to prevent buffer overflow and other congestion problems (such as lock up problems or unacceptably high delay).

This study deals with the mathematical modeling and analysis of such buffering and flow control in message switched networks. The work presented here consists of two major parts.

- 1) A gradual input queue model is developed and used to investigate the theoretical buffer requirements of a class of message switched networks.
- 2) The problem of optimal buffer allocation and flow control is investigated for tree concentration structures within such networks.

The message switched networks considered in this study are of the general type shown in Figure 1.1. The networks consist of sources and destinations interconnected by directed communication channels through buffered message switching nodes. Some of the nodes are connected in concentrating tree structures. The tree structures are then interconnected with each other by a network whose structure is not restricted. In this general class of network structures, the trees are the "local distribution" part of the network while the network interconnecting the trees is the "long distance" network. Since tree structures are less difficult to analyze than general networks, particular emphasis is placed on them in this study. They are the only structures in which flow control is studied. This emphasis is also supported by the fact that the "local distribution" costs are a very significant part of the total cost of a message switched network.

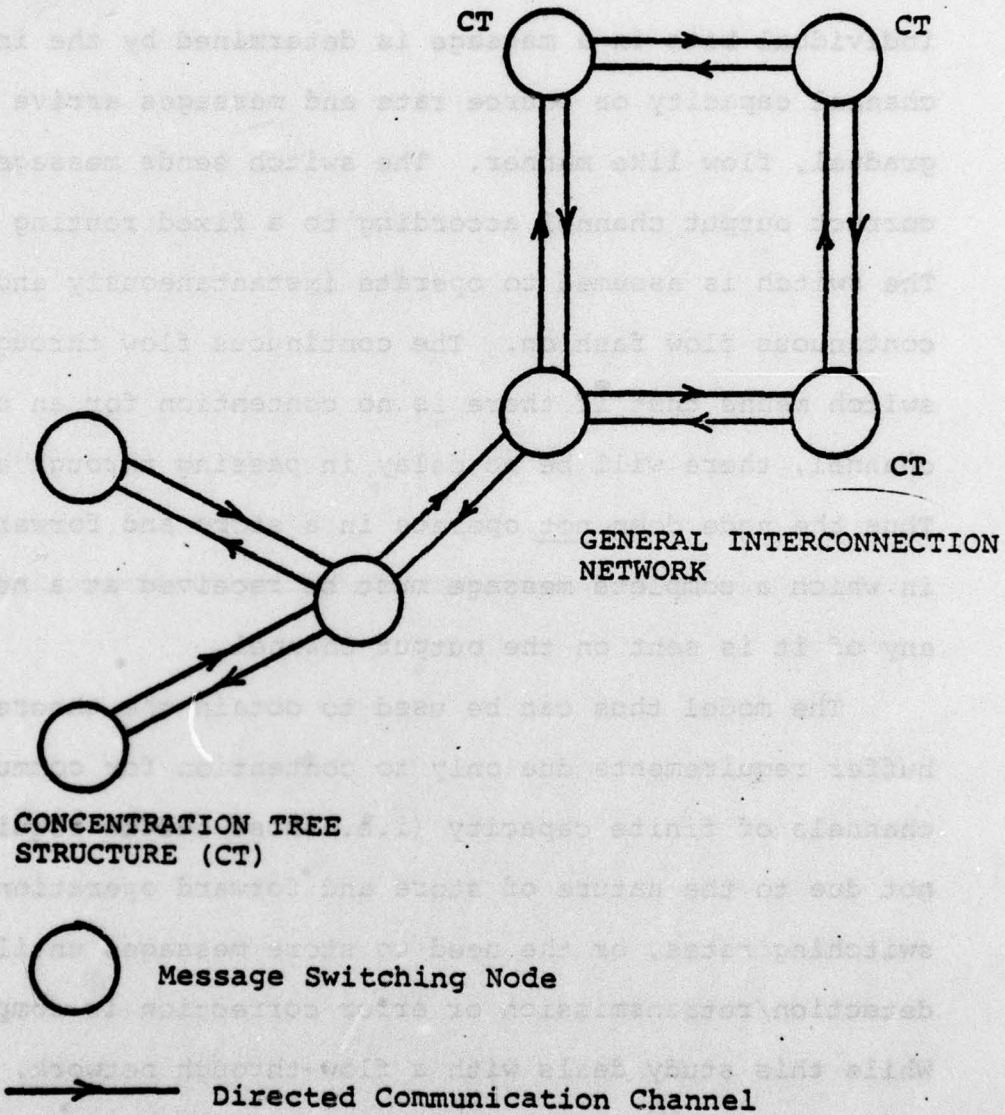

FIGURE 1.1 - General class of message switched networks studied

An enlarged view of a message switching node is shown in Figure 1.2a. Traffic arrives at a node over input channels as an on/off process. The rate of arrival of the individual bits in a message is determined by the input channel capacity or source rate and messages arrive in a gradual, flow like manner. The switch sends messages to the correct output channel according to a fixed routing policy. The switch is assumed to operate instantaneously and in a continuous flow fashion. The continuous flow through the switch means that if there is no contention for an output channel, there will be no delay in passing through a node. Thus the node does not operate in a store and forward manner, in which a complete message must be received at a node before any of it is sent on the output channel.

The model thus can be used to obtain the theoretical buffer requirements due only to contention for communication channels of finite capacity (i.e. those buffer requirements not due to the nature of store and forward operation, finite switching rates, or the need to store messages until error detection/retransmission or error correction is complete.). While this study deals with a flow-through network, many of the insights obtained are applicable to store and forward networks as well.

The study assumes that buffers in the nodes are associated with only one output channel. This is not as efficient as one shared buffer pool for all output lines, but serves to make

Input Channels

Output Channels

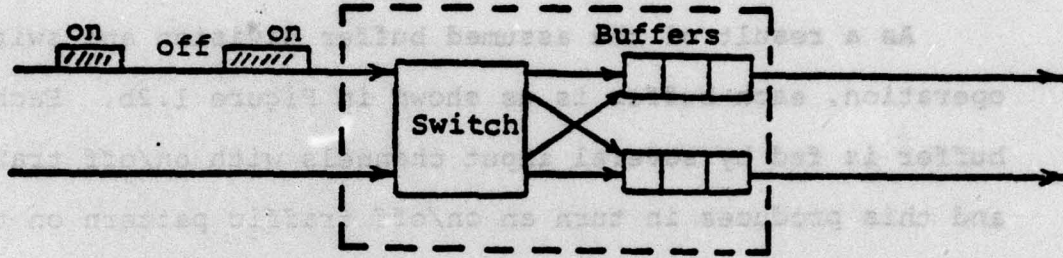

a. Message switching node structure.

Inputs

Buffer

Output

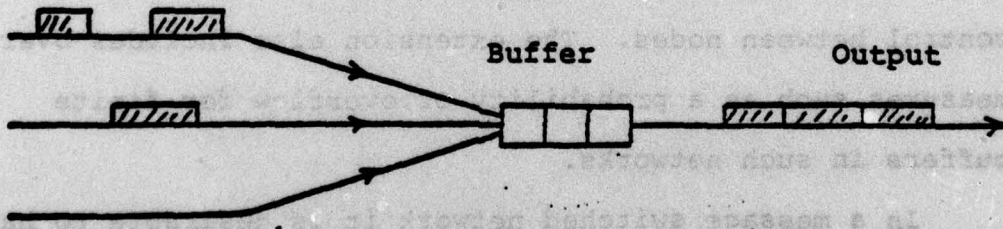

b. Input and output traffic for each buffer.

FIGURE 1.2 - Buffering in a message switched node

the mathematical analysis feasible. The division of buffer capacity in a node can also be supported by the fact that in actual systems, each output channel might have a dedicated communications processor with its own buffer.

As a result of the assumed buffer division and switch operation, each buffer is as shown in Figure 1.2b. Each buffer is fed by several input channels with on/off traffic and this produces in turn an on/off traffic pattern on the output channel. The stochastic model of this buffer is called a gradual input queue. It has been studied by Cohen, Rubinovitch and Kaspi [COHEN 74, RUBIN 73, KASPI 75] and it is the basic model that is used in this study.

Previously, the gradual input queue model has been analyzed for networks of converging tree structures with infinite buffers at each node. The first major part of this study extends this model to general networks using a fixed routing policy for messages and no blocking or flow control between nodes. The extension also includes overflow measures such as a probability of overflow for finite buffers in such networks.

In a message switched network it is desirable to have flow control measures that can relieve congestion at a communication channel by reducing the rate of inflow to that channel. To analyze even simple flow control policies for general networks is extremely difficult. Therefore,

this study considers flow control only in converging tree structures. The second major part of this study investigates the optimal buffer allocation and flow control for such structures. The flow control considered involves flow rules that do not allow buffer overflows in the interior of the tree structure. Therefore, all overflows occur at source nodes where it would presumably be straightforward to turn off sources to avoid lost traffic.

In recent years there has been considerable interest in the analysis of message switched networks, flow control and related queueing problems. A survey of previous studies in these areas, discussed from the viewpoint of their relation to this study, is given in the next section.

1.2 Previous Studies of Buffering and Flow Control

An early analytic study of the queueing processes that occur in the buffers of message switched communication networks was done by Kleinrock [KLEIN 64]. Kleinrock modeled buffered communication channels as exponential service time (message transmission time) queues with Poisson input streams of messages and infinite buffers (i.e. M/M/1 queues). A communication network is then represented by a network of such queues. On the basis of the result that the output process of an M/M/1 queue is Poisson [BURKE 56], Kleinrock argued that each queue in the network could be analyzed by merely determining the mean arrival rate into it. Each

queue in the network behaves the same as a single M/M/1 queue not in a network. This has been formalized by Jackson [JACK 57]. Jackson showed that for certain networks of queues, the steady state joint distribution for the number of customers at each queue has a product form. Each term in the product is the same as the distribution for an independent queue with the appropriate mean arrival rate. Using the network of queues model, Kleinrock considered a number of network design problems, including finding the communication channel capacity allocation which minimizes the expected delay through the network subject to a total network cost constraint. While buffer occupancy statistics were not explicitly considered in this study, it is straight forward to obtain the steady state results using the network of queues model.

It is important to examine the assumptions that were required to make the network of queues model mathematically tractable. The main assumption is that if a message passes through more than one communication channel, its length (service time) is chosen independently at each queue (channel) through which it passes. This independence assumption is necessary to remove the statistical dependence between the interarrival times and message lengths of adjacent messages in the network. A second assumption is that at the time of a message arrival, all of the information bits associated with that message arrive instantaneously at the channel buffer. Clearly, if the communication channels have finite

capacity, the information bits arrive gradually, not instantaneously. The gradual input queueing models to be used in this study do not use either of these assumptions. Some assumptions will have to be made, however, for the gradual input model as well and they have some relation to the independence assumption used by Kleinrock. In particular, the gradual input queue analysis requires that the statistics of all input channels be independent. If in a general network, traffic with a common destination is routed over two paths that share some channels, separate and then again share some channels, this will require a type of independence assumption. The independence assumption is, however, not made for directly adjacent nodes.

A network of queues model has recently been used by Lam [LAM 76] to study the buffer requirements in a packet switched network when each node of the network has only a finite storage capacity. The network is assumed to operate on a store and forward basis with link by link acknowledgement of messages. Using basically the same assumptions as Kleinrock in a more complex model, Lam obtains approximate results for the probability of nodal blocking due to buffer overflow. The study also develops a heuristic algorithm for determining a balanced assignment of buffer capacities in the network.

Another study of the queueing processes in networks of finite length queues representing message switched communication networks has been done by Borgonovo and Fratta [BORG 73]. This study approached the problem by using an exact Markovian state space model to represent the dynamic operation of the network. Such a model is feasible only for very small networks with few buffers because the size of the state space grows extremely rapidly as the size of the network increases. To overcome this problem, heuristic upper and lower bounds were developed for the probability of nodal blocking due to buffer overflow for symmetric ring networks. Borgonovo and Fratta overcame the independence assumption by working in discrete time with fixed length messages.

In addition to the above studies of complete networks, there have been numerous studies of the queueing processes associated with just one communication channel or one node of a message switched network [HSU 73, HSU 74, PACK 74, CHU 70A, CHU 70B, GORD 70, RUDIN 70, CHU 73, RICH 75, CHU 69, IRLND 75, WYNER 74]. Most of the studies assume that messages arrive as a Poisson process in an instantaneous manner. A study which does not make this assumption has been done by Gordon, Meltzer and Pilc [GORD 70]. This study investigates the operation of a statistical multiplexor for message switched traffic that comes from a finite number of two state Markov sources by simulation. The sources are either in the on

state or in the off state and in the on state they generate a steady stream of characters at a finite rate. This is much like the source model that will be used in this study of the gradual input queue. The Gordon study gives the buffer capacities needed to meet certain probability of buffer overflow requirements. The average character delay through the buffer was also obtained.

Flow control in a message switched network designed for computer-communication became a topic of interest during the design and subsequent operation of the ARPANET. The flow control mechanisms used in the ARPANET are discussed by Kahn and Crowther [KAHN 72]. Two basic mechanisms are used, one for source to destination flow control and one for node to node flow control.

The source to destination flow control is achieved by defining a link to be a unidirectional logical connection between users of the network and then controlling the number of messages outstanding on a link at any one time. In ARPANET, the rule used is that there can be only one message outstanding on a link at a time. This rule is enforced by sending a "request for next message" (RFNM) from the destination to the source after each message is received. The source does not send the next message until it receives the RFNM.

The node to node flow control in ARPANET is based on a system of acknowledgement messages (ACKS). After a node sends a message to the next node, it keeps a copy of the message until it receives an ACK for that message from the receiving node. Therefore, if the receiving node has no buffer space available, it can simply discard an incoming message and not send an ACK for that message. Then, after waiting a specified length of time and not receiving an ACK, the sending node will retransmit the message.

Both the source to destination and the node to node flow control serve to effectively control congestion in many circumstances. In some situations, however, these mechanisms can lead to lockup conditions or otherwise reduce network throughput. The avoidance of such lockup conditions and reduced throughput has led to modification of the specific flow control rules for ARPANET. The basic concepts still apply, however.

There is only a limited amount of theoretical literature on flow control. One scheme that has been proposed and analyzed to some extent is isarithmic flow control. Isarithmic flow control was first described by Davies [DAV 72]. The basic idea is to have a fixed number of message carriers that are used to send messages through the network. An input message must wait for a carrier to be available at the input

node before it can progress through the network. When a carrier is empty, it circulates at random through the network until it arrives at a node that has traffic for it.

The main parameter associated with isarithmic flow control is the number of message carriers in the network. Davies has shown by simulation that throughput is a function of the number of carriers. If there are too few carriers, traffic is needlessly rejected at the inputs, while if there are too many carriers, congestion occurs. Davies points out that isarithmic flow control is not designed to completely replace other flow control mechanisms. In addition to the simulation study, Sencer [SENCER 74] has developed an analytic queueing model for isarithmic flow control.

The analytic evaluation of flow control mechanisms is in general very difficult. Recognizing this, Chou and Gerla [CHOU 75] have proposed a framework in which to classify and then develop simulation models for such mechanisms. Their scheme, called the unified flow control model, recognizes that messages are allowed to enter a network or proceed through it only if 1) in some sense the buffers required have been allocated at the point of entry and/or if 2) the number of occupied buffers is below some threshold. Various flow control mechanisms differ in the rules for allocation and in the thresholds that are defined. Once these rules have been identified for a given mechanism, it can be simulated in the framework of the unified flow control model.

Some reference to a flow control scheme that is similar to the rate flow control considered in this study has been made in a survey by Gerla and Chou [GERLA 74]. The survey mentions a proposed flow control strategy due to Pouzin that controls input rates on the basis of the information in flow control tables which are circulated in the network. The flow control considered in this study also controls flow rates. Extensive flow control tables are, however, not needed in this study since it is limited to concentration tree structures. In such structures flow control can consist of simply reducing the flow rate of upstream nodes whenever downstream nodes become congested. The flow control problem for a general network is much more complicated and Pouzin has apparently not analyzed his proposed scheme mathematically.

1.3 Summary of Results

A single gradual input queue is first considered in detail since it is the basis of this study. Chapter 2 presents the previously known results for this model and a number of extensions. An important extension required for this study is a probability of overflow measure for a queue with a finite buffer. The probability of overflow per busy period is found and a useful exponential upper bound for it is also obtained. It is shown how this overflow measure can be converted to an expected time between overflows. Other

overflow measures are also discussed. A final extension for the single queue is the development of upper and lower bounds for the expected delay per bit through the buffer.

In previous buffering studies of message switched networks the M/M/1 queue model has been extensively used. The gradual input model is therefore compared to the M/M/1 model. Such a comparison for single queues is presented at the end of Chapter 2. It is shown that the gradual input model enables one to see effects due to a finite number of finite rate traffic sources that are not apparent with the M/M/1 model. All of these effects reduce the amount of queuing from that calculated with the M/M/1 model.

The analysis of a network of gradual input queues is presented in Chapter 3. It is first shown that all traffic streams in a general network are not exactly of the type required for the analysis presented in Chapter 2. Specifically, all traffic streams will not be alternating renewal processes with exponential off times even if the source traffic streams are of this type. It is shown, however, that if source streams have both exponential on and off times it is a good approximation to assume that all traffic streams in the network are of this type. This is verified mathematically for two limiting cases and by simulation.

The analysis of a general network of gradual input queues is then done by first calculating the mean on and off times associated with all traffic streams. Two sets of linear equations are developed for this purpose. Once the mean traffic parameters have been found, the analysis presented in Chapter 2 can be applied to obtain marginal statistics for each buffer in the network.

The results for networks of gradual input queues are also compared with those obtained using a network of M/M/1 queues. Again the finite source nature of the gradual input model shows network effects that cannot be seen with the M/M/1 model.

Flow control is investigated for tree concentration structures. The flow control is used to eliminate overflows in the interior of the tree. Therefore all overflows occur at source nodes where it would presumably be easy to turn off the sources. The first problem considered is finding the buffer allocation in such a tree that minimizes the probability of buffer overflow. It is shown that in certain cases, placing all buffers at source nodes is the desired allocation. This is not a general result, however. A counterexample is presented that gives insight into why it is not always desirable to place all buffers at source nodes.

Even though reasonable flow control rules can sometimes be specified, it is often difficult to analyze the performance of the resulting system. To help deal with this problem, an approximate analysis of a small concentration tree using flow control is presented. The analysis is based on a first passage time theorem for Markov chains. The theorem states that the tail behavior of first passage time distributions is geometric or exponential under fairly general conditions. This is used to develop a stage by stage analysis of a three node system by coupling the dynamics of the nodes in an approximate way. The results obtained in this way for the system probability of overflow are verified by simulation.

CHAPTER II - THE ANALYSIS OF A SINGLE GRADUAL INPUT QUEUE

Before considering the analysis of an entire message switched network, it is necessary to analyze a single gradual input queue. The first section of this chapter presents the basic definitions and results for the gradual input queueing model due to Rubinovitch, Cohen and Kaspi. In addition, results for specific cases of interest in this study are obtained and a delay analysis for the queue is developed. The next section considers overflow statistics for a gradual input queue with a finite buffer. The final section compares the gradual input queue with the simpler M/M/1 queue in order to show the insights obtainable from the more detailed model.

2.1 The Basic Gradual Input Queue Model

2.1.1 Definitions and previous results

The following description of the gradual input queue parallels that of Cohen [COHEN 74]. The model represents N incoming channels being multiplexed onto a single outgoing channel as is shown in Figure 2.1a. The capacity of each of the incoming channels is the same as that of the outgoing channel, so that when only one incoming channel is on, data passes directly through the multiplexor without buffering or delay. When more than one incoming channel is on, a queue builds up. The buffer is assumed to have infinite capacity and is shared by all incoming channels. The outgoing channel

sends data at a constant rate whenever any incoming channel is on or there is data in the buffer.

The on and off process associated with each incoming channel is taken to be an alternating renewal process. As shown in Figure 2.1b, for the i th channel this process is described by the sequence $\sigma_{1,i}, \tau_{1,i}, \sigma_{2,i}, \tau_{2,i}, \dots$ of statistically independent nonnegative random variables. The random variables $\sigma_{n,i}$ ($n = 1, 2, 3, \dots$) represent the successive idle periods on the i th channel and the random variables $\tau_{n,i}$ ($n = 1, 2, 3, \dots$) represent the lengths of the successive busy periods on that channel. The random variables $\sigma_{n,i}$ have distribution $A(\cdot)$ while the random variables $\tau_{n,i}$ have distribution $B(\cdot)$. The restriction that the processes on all input channels be identically distributed will be removed later.

Figure 2.2 shows the behavior of the gradual input buffer for a specific sample function of the input. A period of continuous inflow into the buffer is called an inflow period and its length is denoted by l_j . The sum of the lengths of all messages flowing into the buffer during the j th inflow period is called the load h_j . A busy period of the buffer is a period of uninterrupted flow on the output channel. Its length is denoted by b . The length of time between the start of successive busy periods is called a busy cycle, whose length is denoted by c . The length of time between the end of the n th and the beginning of the $(n+1)$ st

inflow period is denoted by w_1 . A final quantity defined by Figure 2.2 is the content of the buffer at the start of the new inflow period, denoted by w_2 .

In order to facilitate the analysis of the gradual input queue, it is necessary to restrict the distribution of off times of the input channels to be exponential, i.e.,

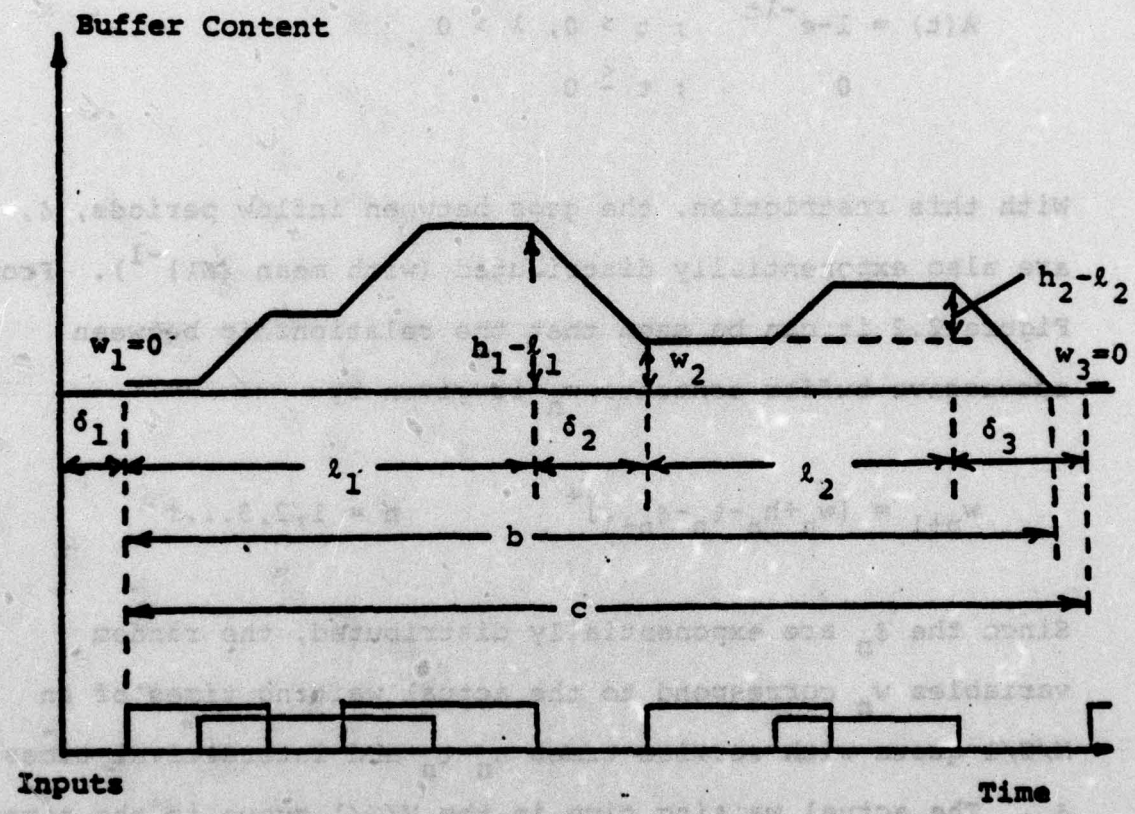

FIGURE 2.2 - The buffering process in a gradual input queue (After Fig. 3 in [COHEN 74])

inflow periods is denoted by δ_{n+1} . A final quantity defined by Figure 2.2 is the content of the buffer at the start of the nth inflow period, denoted w_n .

In order to facilitate the analysis of the gradual input queue, it is necessary to restrict the distribution of off times on the input channels to be exponential, i.e.

$$A(t) = \begin{cases} 1 - e^{-\lambda t} & ; t > 0, \lambda > 0 \\ 0 & ; t \leq 0 \end{cases}$$

With this restriction, the gaps between inflow periods, δ , are also exponentially distributed (with mean $(N\lambda)^{-1}$). From Figure 2.2 it can be seen that the relationship between successive buffer contents w_n is given by

$$w_{n+1} = [w_n + h_n - l_n - \delta_{n+1}]^+ \quad n = 1, 2, 3, \dots$$

Since the δ_n are exponentially distributed, the random variables w_n correspond to the actual waiting times of an M/G/1 queue with service times $h_n - l_n$ and interarrival times δ_n . The actual waiting time in the M/G/1 queue is the time between the arrival of a customer and the start of his service. This equivalence is the basis of the analysis of the gradual input queue.

$$+ [x]^+ = \begin{cases} x & \text{if } x > 0 \\ 0 & \text{if } x \leq 0 \end{cases}$$

In order to make use of the known results for the M/G/1 queue in analyzing the gradual input queue, it is necessary to obtain the distribution of $h_n - l_n$. This has been done by Cohen. The central result is given below. Define

$$B^*(\rho) = \int_0^{\infty} e^{-\rho t} dB(t) \quad \text{Re } \rho \geq 0$$

$$\beta = \int_0^{\infty} t dB(t)$$

$$\Lambda = N\lambda \quad a = \Lambda\beta$$

Theorem (Theorem 2.3 [COHEN 74])

For $\text{Re } \rho \geq 0$, $\text{Re } s > 0$, $t > 0$, $\text{Re } u > 0$

$$s + \Lambda \{1 - E\{\exp(-\rho h - s l)\}\}^{-1} =$$

$$\left\{ \begin{array}{l} \int_0^{\infty} e^{-st} \left(\frac{1}{2\pi i} \int_{C_u} \frac{e^{ut}}{u + \lambda \{1 - B^*(\rho + u)\}} du \right)^N dt; \quad N < \infty \\ \int_0^{\infty} e^{-st} \exp\left\{ \frac{\Lambda}{2\pi i} \int_{C_u} u^{-2} e^{ut} \{1 - B^*(\rho + u)\} du \right\} dt; \quad N = \infty \end{array} \right. \quad (\text{Eq. 2.1})$$

In this theorem, $N = \infty$ is the case $N\lambda \rightarrow \Lambda$ as $N \rightarrow \infty$, $\lambda \rightarrow 0$. The integral

$$\int_{C_u} e^{ut} F(u) du \equiv \lim_{c \rightarrow \infty} \int_{-ic + Reu}^{ic + Reu} e^{ut} F(u) du$$

where $\epsilon > 0$ and $\text{Re } u$ is to the right of all singularities of $F(u)$. Note that $\frac{1}{2\pi i} \int_{C_u} e^{ut} F(u) du$ is then the inverse Laplace transform of $F(u)$.

Using the above theorem, it is possible to derive the first moments of the distributions of h and l . There are

For $N < \infty$

$$E\{l\} = (\beta/a) \{(1+a/N)^{N-1}\}$$

$$E\{h\} = \beta(1+a/N)^{N-1} \quad (\text{Eq. 2.2})$$

For $N = \infty$

$$E\{l\} = (\beta/a) (e^a - 1)$$

$$E\{h\} = \beta e^a \quad (\text{Eq. 2.3})$$

For the equivalent M/G/1 queue it is known that the queueing process will have a steady state as $t \rightarrow \infty$ only if $\lambda E(h-l) < 1$. Cohen has shown that for the gradual input queue, the following equivalence exists.

$$\lambda E(h-l) \begin{cases} < 1 & \iff (N-1)\lambda\beta < 1 \quad \text{if } N < \infty \\ & \quad \quad \quad a < 1 \quad \quad \quad \text{if } N = \infty \\ \\ = 1 & \iff (N-1)\lambda\beta = 1 \quad \text{if } N < \infty \\ & \quad \quad \quad a = 1 \quad \quad \quad \text{if } N = \infty \end{cases}$$

Having found the expected value of $h-l$ and the conditions under which the queueing process has a steady state, it is now possible to apply the following theorem by Cohen to obtain a useful measure of the buffer build up occurring in a gradual input queue.

Theorem (Theorem 3.4 [COHEN 74])

The maximum content C_{\max} of the buffer during a busy cycle has the same distribution as the distribution of the maximum virtual waiting time v_{\max} during a busy cycle of an M/G/1 queue with a service time distribution which is the same as that of $h_n - l_n$ and mean interarrival time Λ^{-1} . The virtual waiting time, $v(t)$, of the M/G/1 queue is the total remaining service time of the customers in the queue at time t . This is the time a customer would have to wait before starting service if he arrived at time t . Note that this is not the same as the actual waiting time since $v(t)$ is defined for all t while actual waiting times are defined only at the customer arrival times [COHEN 69].

A result for v_{\max} of an M/G/1 queue with mean service time x and mean interarrival time d which can now be applied is

$$E(v_{\max}) = d \log[(1-x/d)^{-1}] \quad (\text{Eq. 2.4})$$

as given in [COHEN 69]. Applying Equations 2.2 and 2.3, one obtains the following.

$$E\{C_{\max}\} = \begin{cases} a^{-1}\{\log(1-a)^{-1} - a\}\beta & N=\infty \\ a^{-1}\{\log(1-a(N-1)/N)^{-1} + (N-1)\log(1+a/N)^{-1}\}BN & N < \infty \end{cases}$$

It is therefore possible to calculate the expected value of the maximum buffer content during a busy cycle in closed form.

Another useful result that has been obtained for the gradual input queue is the functional form of the distribution of the busy period on the output channel. Rubinovitch [RUBIN 73] has shown that the output channel of a gradual input queue has the same busy period distribution as an M/G/1 queue with input rate $(N-1)\lambda$ and service time distribution $B(\cdot)$.† If $D^*(\cdot)$ is the Laplace Stieltjes transform of the distribution of the busy period on the output channel then

$$D^*(\theta) = B^*((N-1)\lambda + \theta - (N-1)\lambda D^*(\theta)) \quad \text{Re } \theta > 0$$

This is the well known busy period result for an M/G/1 queue [KLEIN 75].

The results so far apply only to a single stage of buffering. It is, however, straight forward to extend the results to several stages of channels arranged in a converging tree structure. This is done by observing that the output

†Note that this M/G/1 analogy is not the same as the one used to obtain the previous buffering result.

channel of one stage behaves as an alternating renewal process as required for it to be the input process to the next stage. It is therefore possible to analyze a converging tree structure in a stage by stage manner.

This section has been restricted to queues for which all input channels have identical alternating renewal processes. The results presented here have been generalized to the case of different renewal processes† for each input channel by Kaspi and Rubinovitch [KASPI 75]. A summary of their work is given in Appendix A.

2.1.2 Equivalent M/G/1 queue service time analysis

In the previous section it was shown that the queueing process in a gradual input queue can be analyzed by making an analogy with an M/G/1 queue. The equivalent M/G/1 service time distribution is the same as the distribution of $h-l$, the queue buildup during an inflow period of the gradual input queue. In this section the Laplace transform of the distribution of $h-l$ is obtained for specific cases. The specific cases considered are ones in which the on times, $\tau_{i,j}$, as well as the off times, $\sigma_{i,j}$, on the input channels are exponentially distributed. These special cases are required for the analysis of the general networks presented in Chapter 3.

†The off periods on each channel are still required to be exponentially distributed.

The results presented here are obtained by using a Markov chain representation for the behavior of the input channels to the queue. This approach is easier to understand than using the relationship given by Cohen for $E\{\exp(-\rho h - s l)\}$.[†] It also allows one to analyze queues for which the input channel capacity is larger than that of the output channel.

[†]Cohen's result (Theorem 2.3 [COHEN 74]) is stated in the previous section. Note that it gives $E\{\exp(-\rho h - s l)\}$ for $\text{Re } \rho > 0, \text{Re } s > 0$. Therefore in order to use the result to obtain $E\{\exp(-\rho(h-l))\}$ analytic continuation must be used. Appendix A-4 of [COHEN 74] shows how to do this for the case of an infinite number of input channels ($N=\infty$). The result for this case is that for $\rho > 0$,

$$\frac{\rho - \Lambda\{1 - B(\rho)\}}{\rho - \Lambda\{1 - E\{\exp[-\rho(h-l)]\}\}} =$$

$$= 1 - \Lambda \int_0^{\infty} E\{\exp[-\rho(\delta-t)] (\delta-t)\} \exp\left[-\frac{\Lambda}{2\pi i} \int_{C_u} u^{-2} e^{ut} \{1 - B(\rho+u)\} du\right] dt$$

Where δ has distribution $B(\cdot)$ and $(\delta-t) = 1$ if $\delta > t$ and 0 otherwise

The alternating on/off renewal process associated with a communication channel on which these times are exponentially distributed can be represented as a two state continuous time Markov chain. Let the off times have distribution function

$$A(t) = \begin{cases} 1 - e^{-\lambda t} & t > 0, \lambda > 0 \\ 0 & t \leq 0 \end{cases}$$

and the on times have distribution function

$$B(t) = \begin{cases} 1 - e^{-\mu t} & t > 0, \mu > 0 \\ 0 & t \leq 0 \end{cases}$$

Then the behavior of the channel can be represented by the Markov chain shown in Figure 2.3a. If there are N independent input channels, their joint behavior can also be represented by a Markov chain. The chain representing the joint behavior of three identical input channels is shown in Figure 2.3b. The states of the chain are the number of channels on and the number off. The transition times between the states are exponentially distributed as required for the system to be a continuous time Markov chain. This follows from the memoryless property of the exponential distribution and the fact

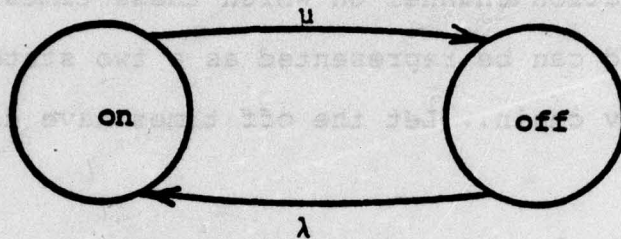

a. A single gradual input channel.

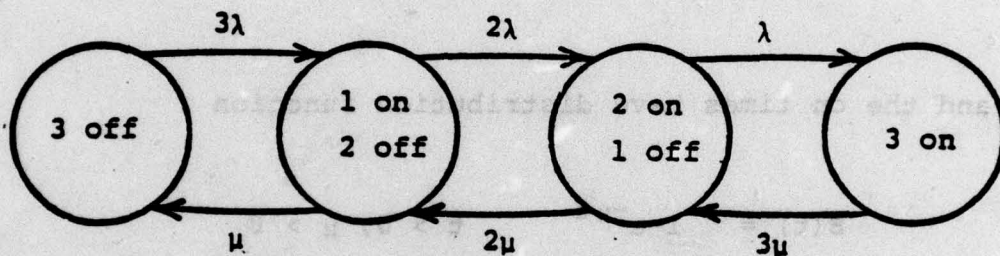

b. Three identical gradual input channels.

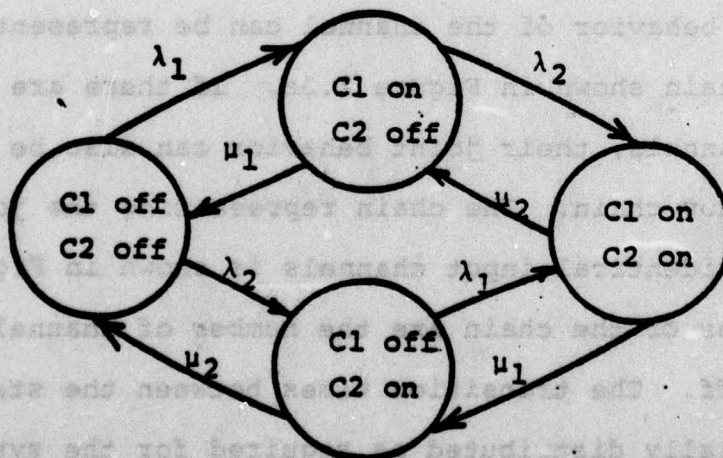

c. Two different gradual input channels.

FIGURE 2.3 - Rate diagrams for Markov chain representations of the behavior of gradual input channels

that the time to a state transition is given by the minimum of a set of independent exponential distributions (the set of times until the next transition on each channel). It is well known that the minimum of such a set is exponentially distributed.

It is also straightforward to extend the Markov chain representation to independent input channels with different traffic parameters. Figure 2.3c illustrates the Markov chain for the joint behavior of two input channels with mean on and off times $(\mu_1^{-1}, \lambda_1^{-1})$ and $(\mu_2^{-1}, \lambda_2^{-1})$.

Now recall that the quantity $h-l$ is the queue buildup during an inflow period of the gradual input queue. This time period can easily be identified in the Markov chain representation of the input channels. An inflow period starts with a transition from all inputs off to one input on and ends on the first return to the state with all inputs off. Therefore an inflow period is a first passage event in this Markov chain.

The excess queue buildup, $h-l$, during this first passage event can now be identified. This can be done for queues with input channel capacities, C_i , which are greater than or equal to the output channel capacity, C_o . For such a queue, whenever the input channels are in a state with N_{on} input channels on, the buffer content of the queue increases at rate κ_b , where

$$r_b = N_{\text{on}} C_i - C_o \quad N_{\text{on}} \geq 1, \quad C_i \geq C_o \quad (\text{Eq.2.5})$$

Equation 2.5 can now be used to scale the transition time distributions for the input channel Markov chain so that the time spent in each state represents the excess queue buildup while in that state. In the resulting scaled Markov chain, the time for the first passage event that starts from the all channels off state with one input coming on and ends upon the first return to the all off state is equal to the quantity $h-l$.

The use of the scaled Markov chain to determine the Laplace transform $H^*(s)$ of the distribution of $h-l$ is best illustrated by an example. The unscaled Markov chain representing three identical gradual input channels was shown in Figure 2.3b. If these channels have capacity $C_i = C_o = 1$, then the scaled Markov chain representing the rate of queue buildup will be as shown in Figure 2.4. Note that state 1 (all channels off) is shown as a trapping state because it is the end state of the first passage event of interest. As such, the time until trapping in state 1 will be the same as the first passage time to that state. Also note that since there is no queue buildup in state 2 (one input on), there are infinite transition rates out of this state in the scaled chain.

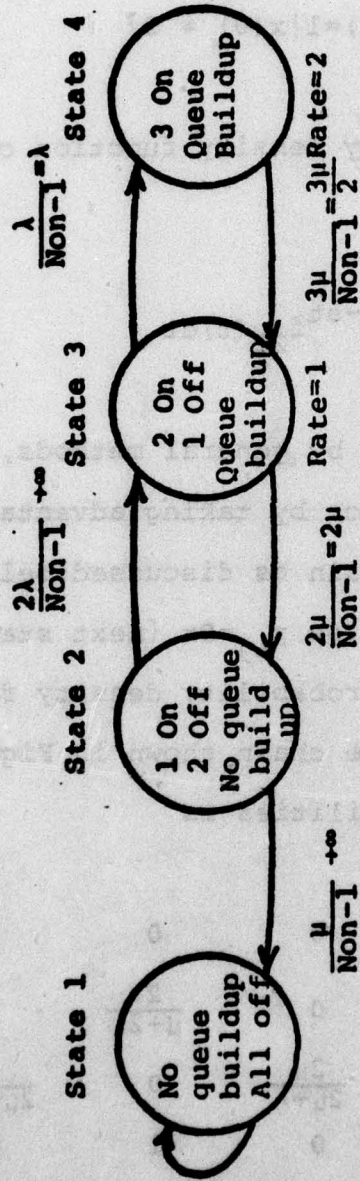

FIGURE 2.4 - Scaled Markov chain for finding $H^*(s)$, the Laplace transform of the queue build up during an inflow period

Let $x(t)$ be the state of the scaled Markov chain. Then, as discussed previously, $h-l$ is equal to the following first passage time

$$h-l = f_{21} = \inf\{t; x(t)=1 | x(0) = 2\}$$

If $f_{21}(t)$ is the probability density function of f_{21} , then the desired transform is

$$F_{21}^*(s) = H^*(s) = \int_{t=0}^{\infty} e^{-st} f_{21}(t) dt$$

This transform can be found by general methods, such as those given by Howard [HOWD 71], or by taking advantage of the special structure of the chain as discussed below. In either case, transition probabilities $p_{ij} = \Pr \{\text{next state}=j | \text{current state}=i\}$ and waiting time probability density functions $w_{ij}(t)$ must be identified. For the chain shown in Figure 2.4, the matrix of transition probabilities is

$$P = \begin{bmatrix} 1 & 0 & 0 & 0 \\ \frac{\mu}{\mu+2\lambda} & 0 & \frac{2\lambda}{\mu+2\lambda} & 0 \\ 0 & \frac{2\mu}{2\mu+\lambda} & 0 & \frac{\lambda}{2\mu+\lambda} \\ 0 & 0 & 1 & 0 \end{bmatrix}$$

The density functions $w_{ij}(t)$ are the densities of the time until transition, given that a transition from state i to j will occur, and zero if a direct transition is not possible from i to j . For the continuous time Markov chain under consideration here, these are all exponential. The mean times are the mean time spent in each state. Therefore the matrix of these densities is

$$\bar{W}(t) = \begin{bmatrix} w_{11}(t) & 0 & 0 & 0 \\ \delta(t) & 0 & \delta(t) & 0 \\ 0 & (\mu+2\lambda)e^{-(\mu+2\lambda)t} & 0 & (\mu+2\lambda)e^{-(\mu+2\lambda)t} \\ 0 & 0 & \frac{3\mu}{2}e^{-\frac{3\mu}{2}t} & 0 \end{bmatrix} t \geq 0$$

Where $\delta(t)$ is the Dirac delta $\delta(t) = \begin{cases} 1 & t=0 \\ 0 & \text{otherwise} \end{cases}$.

Since state 1 is a trapping state, $w_{11}(t)$ can be any probability density function such that $w_{11}(t) = 0$ if $t < 0$.

From the matrix $\bar{W}(t)$ it is easy to generate the matrix of Laplace transforms of the waiting time densities.

$$W^*(s) = \begin{bmatrix} w_{11}^*(s) & 0 & 0 & 0 \\ 1 & 0 & 1 & 0 \\ 0 & \frac{\mu+2\lambda}{s+\mu+2\lambda} & 0 & \frac{\mu+2\lambda}{s+\mu+2\lambda} \\ 0 & 0 & \frac{3\mu}{2s+3\mu} & 0 \end{bmatrix}$$

Because of the simple structure of the Markov chain, the transform $F_{21}^*(s)$ can easily be found by the following method. Let Y_{23} and Y_{34} be the number of state 2 to state 3 and state 3 to state 4 transitions that are made during the first passage event starting from state 2 and ending in state 1. Knowing Y_{23} and Y_{34} is equivalent to knowing the number of times states 2, 3, and 4 were entered before the trapping state 1 was reached. The transform $F_{21}^*(s)$ can therefore be found by summing conditional transforms as follows

$$\begin{aligned}
 F_{21}^*(s) &= \sum_{\text{All possible } j,k} \{F_{21}^*(s) | Y_{23}=j, Y_{34}=k\} \\
 &\quad \Pr\{Y_{23}=j, Y_{34}=k\} \\
 &= w_{21}^*(s) P_{21} \sum_{\text{All possible } j,k} (w_{23}^*(s) w_{32}^*(s))^j \\
 &\quad (w_{34}^*(s) w_{43}^*(s))^k (P_{23} P_{32})^j (P_{34} P_{43})^k \\
 &= w_{21}^*(s) P_{21} \sum_{j=0}^{\infty} (w_{23}^*(s) w_{32}^*(s) (\sum_{i=0}^{\infty} (w_{34}^*(s) w_{43}^*(s) \\
 &\quad P_{34} P_{32})^i) P_{23} P_{32})^j \tag{Eq. 2.6}
 \end{aligned}$$

Equation 2.6 states that there can be $j=0,1,2,\dots$ transitions from state 2 to state 3 and for each of these there can be $i=0,1,2,\dots$ transitions from state 3 to state 4 before trapping

in state 1. For each state 3 to state 4 transition, the transform of the time from starting in state 3 until returning to that state is $w_{34}^*(s)w_{43}^*(s)$. This transition occurs with probability $p_{34}p_{43}$. Similarly, for each state 2 to state 3 transition, the transform of the time from starting in state 2 until returning to that state is $w_{23}^*(s)w_{32}^*(s) \left(\sum_{i=0}^{\infty} (w_{34}^*(s)w_{43}^*(s)p_{34}p_{43})^i \right)$. The last sum accounts for transitions to state 4 once state 3 is reached. The transition from state 2 to state 3 and back to 2 occurs with probability $p_{23}p_{32}$. Finally, each first passage event considered here involves one transition from state 2 to state 1 which occurs with probability p_{21} and has transform $w_{21}^*(s)$.

An equation similar to Equation 2.6 can be written for other simple gradual input queues. Table 2.1 gives the resulting transforms $H^*(s)$ for the case presented above and other cases that are used in this study.

As mentioned previously, the Markov chain technique can be applied to gradual input queues with channel capacities $C_1 > C_0$. One example of this is given in Table 2.1. The Markov chain technique cannot be applied if $C_1 < C_0$ because then the basic M/G/1 queue analogy no longer holds. The M/G/1 analogy requires that the queue content be nondecreasing during an inflow period and that is not the case if $C_1 < C_0$. Unless otherwise stated, all cases considered in this study have $C_1 = C_0$.

TABLE 2.1

$H^*(s)$ for simple gradual input queues.
 Input channels have both on and off times exponentially distributed.

Mean on time = μ^{-1} . Mean off time = λ^{-1} .

A. Input channel capacities, C_1 , equal output channel capacity, $C_0 = 1$.

Number of Inputs

$$H^*(s) = E[\exp-s(h-l)]$$

2 identical

$$\frac{\mu(s+2\mu)}{(\mu+\lambda)s + 2\mu z}$$

3 identical

$$\frac{2\mu s^2 + (2\lambda\mu + 7\mu^2)s + 6\mu^3}{(2\mu + 4\lambda)s^2 + (4\lambda^2 + 8\lambda\mu + 7\mu^2)s + 6\mu^3}$$

4 identical

$$\frac{6\mu s^3 + (5\lambda\mu + 19\mu^2)s^2 + (46\mu^3 + 6\lambda^2\mu + 22\mu^2)s + 24\mu^4}{(6\mu + 18\lambda)s^3 + (19\mu^2 + 15\lambda^2 + 26\lambda\mu)s^2 + (46\mu^3 + 18\lambda^3 + 54\lambda^2\mu + 58\lambda\mu^2)s + 24\mu^4}$$

2 different

$$\frac{\lambda_1\mu_1(\mu_2 + \lambda_1)s + \lambda_2\mu_2(\mu_1 + \lambda_2)s + (\lambda_1 + \lambda_2)\mu_1\mu_2(\mu_1 + \mu_2 + \lambda_1 + \lambda_2)}{(\lambda_1 + \lambda_2)[(\mu_1 + \lambda_2)(\mu_2 + \lambda_1)s + \mu_1\mu_2(\mu_1 + \mu_2 + \lambda_1 + \lambda_2)]}$$

B. Input channel capacities $C_1 \geq C_0$

2 identical inputs

$$\frac{\mu(a_2s + 2\mu)}{a_1a_2s^2 + [(\mu + \lambda)a_2 + 2\mu a_1]s + 2\mu^2}$$

where $a_1 = C_1 - C_0$
 $a_2 = 2C_1 - C_0$

There is another approach to finding $F_{21}^*(s)$ that can be used. Howard [HOWD 71] gives the result that the matrix of first passage time distributions for a continuous time Markov chain satisfies the following relationship.

$$\bar{F}^*(s) = \bar{C}^*(s) [(I - \bar{C}^*(s))^{-1}] [(I - \bar{C}^*(s))^{-1} \square I]^{-1} \quad (\text{Eq. 2.7})$$

The matrix $\bar{C}^*(s)$ is called the core matrix. It is defined as follows

$$\bar{C}^*(s) = \bar{P} \square \bar{W}^*(s)$$

The operator \square in the above equations signifies element by element multiplication of the two matrices. For the gradual input queues considered in this study it is easier to write an equation like Equation 2.6 than to perform the matrix inversions required in Equation 2.7. The infinite sums in Equation 2.6 are all simple geometric sums for which closed form expressions exist.

2.1.3 Bounds for the expected delay per bit

A performance measure that is often of interest for message switched communication networks is delay. In previous studies using the M/M/1 queue as a model, the delay measure usually considered was expected delay per message. For the gradual input model this measure is difficult to find because the distributions obtained for buffer content are not expressed in terms of number of messages. Instead buffer contents are expressed in terms of time units of work (for the output channel) which represent bits when normalized by the communication rate of the output channel. Therefore an expected delay per bit measure will be used for the gradual input queue.

The delay experienced by a specific bit in a gradual input queue is a function of the queue contents at the time of its arrival and of the service discipline of the queue. The service discipline in the queue may be difficult to represent mathematically. For example, suppose that messages are sent on a first-come-first-served (FCFS) basis. Then the bits are not sent strictly FCFS. Fortunately, as long as the service discipline is work conserving, the mean delay per bit remains unchanged.† Therefore the mean delay per bit can be found assuming FCFS service for all bits.

†This follows from Little's formula [LITTLE 61], $L = \lambda W$, which says that the expected delay W for a queue equals the expected queue size L divided by the mean arrival rate λ . All work conserving service disciplines give the same expected queue size in terms of bits for the gradual input queue.

With the FCFS service discipline, it is easy to see that the delay for a specific bit d_b is

$$d_b = \text{buffer content at time of bit arrival}$$

For the gradual input queue, this means that only the queue size during inflow periods is of interest since that is the only time during which bits arrive. Figure 2.5 shows the buffer content during a typical inflow period. Determining the exact delay per bit during this period is very difficult. However, this delay can easily be bounded. Note that at the start of the inflow period the delay (buffer content) is w_i while at the end it is $h_i - l_i + w_i$. The delay is strictly nondecreasing during the inflow period. If one considers M inflow periods, the average delay per bit is bounded by

$$\frac{\sum_{i=1}^M h_i w_i}{\sum_{i=1}^M h_i} \leq \bar{d}_b \leq \frac{\sum_{i=1}^M h_i [h_i - l_i + w_i]}{\sum_{i=1}^M h_i}$$

Taking the limit as $M \rightarrow \infty$ and making an ergodic argument gives

$$\frac{E[hw]}{E[h]} \leq E[d_b] \leq \frac{E[h(h-l+w)]}{E[h]}$$

With the FCFS service discipline, it is easy to see that the delay for a specific bit is $h_i - l_i + w_i$ where h_i = buffer content at time of bit arrival

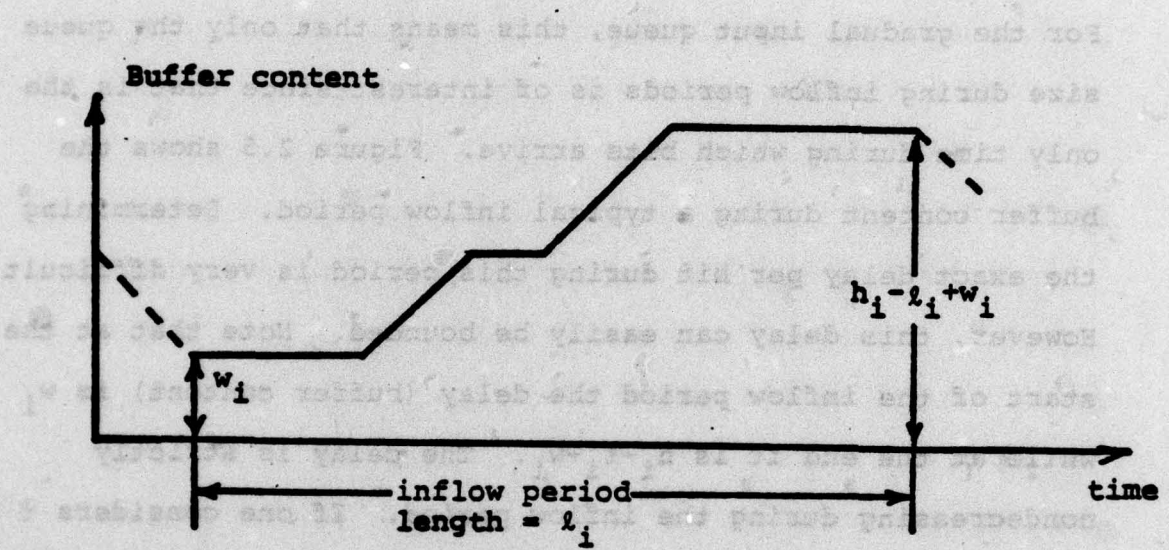

FIGURE 2.5 - A single inflow period of the gradual input queue. The total inflow during the period = h_i

Since h_i and w_i are independent, these bounds simplify to

$$E[w] \leq E[d_b] \leq \frac{E[h(h-l)]}{E[h]} + E[w] \quad (\text{Eq. 2.8})$$

Now recall that w is the actual waiting time of an equivalent M/G/1 queue. Assume that the gradual input queue has N input channels with mean off times λ_i^{-1} ($i = 1, 2, \dots, N$). Then the equivalent M/G/1 queue has mean interarrival time $(\sum_{i=1}^N \lambda_i)^{-1}$ and a service time distribution equal to the distribution of $h-l$. Therefore $E[w]$ can be found using the well known Pollaczek-Khintchine formula [KLEIN 75] for the mean waiting time in an M/G/1 queue.

$$E[w] = \frac{\lambda_T E[(h-l)^2]}{2(1-\lambda_T E[(h-l)])} \quad (\text{Eq. 2.9})$$

$$\text{where } \lambda_T = \sum_{i=1}^N \lambda_i$$

Equation 2.9, together with Equation 2.8, gives both upper and lower bounds on $E[d_b]$ in terms of first and second moments of the fundamental quantities h and l . An example of the bounds is given in Section 2.3.

2.2 The Gradual Input Queue With A Finite Buffer

2.2.1 Probability of buffer overflow in a busy period

A probability of buffer overflow measure is required in order to be able to use the gradual input queueing model to study buffering requirements for a communication network. The key to calculating a probability of buffer overflow for this queueing model with a finite buffer is to use a probability that is convenient to work with. The most convenient is the probability of one or more buffer overflow events during a busy period, and this is the measure used in this study. This measure is convenient because the start of each busy period is a renewal point for the queueing process in the gradual input model. At this point, all but one of the inputs are off with an exponentially distributed time remaining until they come on again. In addition, the buffer is empty so that, stochastically, a queue with an infinite buffer and one with a finite buffer behave identically from the start of a busy period until the finite buffer overflows. For any busy period then, the probability of no overflow for the finite buffer is the same as the probability that the buffer content of the infinite buffer never crosses the level equal to the size of the finite buffer during the busy period.

The analogy between the contents of a gradual input queue and the virtual waiting time in an M/G/1 queue can now be applied. For a gradual input queue with buffer size K

$$\Pr(\text{No overflow during a busy period}) = \Pr(v_{\max} \leq K \text{ during a busy period, of equivalent M/G/1 queue})$$

where the equivalent M/G/1 queue has an infinite buffer, a mean interarrival time of λ^{-1} and a service time distribution that is the same as the distribution of $h-l$. Let w be the actual waiting time for the equivalent M/G/1 queue and y be a random variable with the same distribution as the service time. Then the following result for an M/G/1 queue can be used

$$\Pr(v_{\max} \leq K) = \frac{\Pr(w+y \leq K)}{\Pr(w \leq K)} \quad (\text{Eq. 2.10})$$

Ref. [COHEN 69] p. 525

[TAKACS 65] p. 381

By using the fact that $\Pr(v_{\max} > K) = 1 - \Pr(v_{\max} \leq K)$, Equation 2.10 provides a way of theoretically calculating the probability of one or more overflow events during the busy period of the gradual input queue with buffer size K . Specifically,

$$\begin{aligned} \Pr(\text{Overflow during busy period}) &= 1 - \Pr(v_{\max} \leq K) \\ &= \frac{\Pr(w \leq K) - \Pr(w+y \leq K)}{\Pr(w \leq K)} \\ &= \frac{\Pr(w+y > K) - \Pr(w > K)}{1 - \Pr(w > K)} \quad (\text{Eq. 2.11}) \end{aligned}$$

Because the distributions of w and y for the M/G/1 queue analogy are fairly complicated, it is worthwhile trying to bound the probability of overflow rather than calculating it exactly. This can be done by applying the exponential bounds on the waiting time in G/G/1 queues developed by Kingman [KING 70]. For a G/G/1 queue, denote the service time of the n th customer by x_n and the interval between arrivals of the $(n+1)$ st and n th customer by t_n . Now define the random variable γ_n by

$$\gamma_n = x_n - t_n$$

The γ_n 's are i.i.d. random variables, therefore they have a common distribution function $F(u) = \Pr\{\gamma < u\}$. Kingman has shown that

$$r e^{-\theta^* K} \leq \Pr\{w > K\} \leq e^{-\theta^* K} \quad (\text{Eq.2.12})$$

where the constant r is given by

$$r = \inf_{t > 0} \frac{\int_t^\infty dF(u)}{\int_t^\infty e^{\theta^*(u-t)} dF(u)}$$

and θ^* is the unique greatest positive real root of the equation

$$f(\theta) = \int_{-\infty}^{\infty} e^{\theta u} dF(u) = 1 \quad (\text{Eq.2.13})$$

in an interval I_θ in which $f(\theta)$ is bounded. This interval I_θ includes the origin $\theta=0$ since $f(0)=1$. Furthermore, it can be shown that $f(\theta)$ is a convex U function† and that $f'(0) = E(x-t) < 0$ for a queue with a utilization < 1 . It can also be seen that

$$f(\theta) = A^*(\theta)B^*(-\theta) \quad (\text{Eq. 2.14})$$

where $A^*(\theta)$ and $B^*(\theta)$ are the Laplace transforms of the interarrival time, t_n , and service time, x_n , distributions respectively.

The bound in Equation 2.12 can be applied to Equation 2.11 yielding

$$\text{Pr(overflow)} \leq \frac{\text{Pr}(w+y > K) - e^{-\theta K}}{1 - e^{-\theta K}} \quad (\text{Eq. 2.15})$$

The problem now is to bound the $\text{Pr}(w+y > K)$. This can be done by noting that

$$\text{Pr}(w+y > K) = \text{Pr}(y > K) + \int_{t=0}^K \text{Pr}(w > (K-t)) dH(t)$$

where $H(t)$ is the distribution function of $h-1$.

†The function $f(\theta)$ is convex U if

$$f(a\theta_1 + (1-a)\theta_2) \leq af(\theta_1) + (1-a)f(\theta_2); \quad 0 \leq a \leq 1.$$

Using the fact that $\Pr(y > K) = \int_{t=K}^{\infty} dH(t)$ and that $\Pr(w > 0) = 1$, one obtains

$$\begin{aligned} \Pr(w+y > K) &= \int_{t=0}^{\infty} \Pr(w > (K-t)) dH(t) \leq \int_{t=0}^{\infty} e^{-\theta(K-t)} dH(t) \\ &= H^*(-\theta) e^{-\theta K} \quad (\text{Eq. 2.16}) \end{aligned}$$

This expression for $\Pr(w+y > K)$ can be substituted into Equation 2.15 giving the following exponential bound on the probability of one or more overflows during a busy period of a gradual input queue with buffer size K .

$$\Pr(\text{overflow}) \leq \frac{(H^*(-\theta) - r) e^{-\theta K}}{1 - e^{-\theta K}} \quad (\text{Eq. 2.17})$$

This exponential bound can be applied in a straightforward manner except for the constant r . The constant r is difficult to determine exactly in general. Fortunately, however, it is easy to see from its definition that $r > 0$. Therefore setting $r=0$ still gives an upper bound, i.e.

$$\Pr(\text{overflow}) \leq \frac{H^*(-\theta) e^{-\theta K}}{1 - e^{-\theta K}} \quad (\text{Eq. 2.18})$$

The effect of letting $r=0$ is to weaken the bound, but the correct exponential behavior is preserved. The next section gives an example that illustrates this effect.

It is desirable to have a lower bound as well as an upper bound on the $\text{Pr}(\text{overflow})$ as defined in this section. One can start with Equation 2.10 and apply the Kingman bounds on waiting time to obtain a lower bound, but in this case, since the constant r cannot be determined, the bound is useless. Therefore the alternative that will be used is to realize that for a gradual input queue

$$\begin{aligned} \text{Pr}(\text{overflow}) &= \sum_{i=1}^{\infty} \text{Pr}(\text{Overflow in } i\text{th inflow period}) \\ &> \text{Pr}(\text{Overflow in 1st inflow period}) \\ &= \text{Pr}(h-l > \text{buffer size}) \quad (\text{Eq. 2.19}) \end{aligned}$$

Here only the first inflow period has been used to obtain a lower bound. If a tighter bound is desired, more inflow periods can be considered.

The bounds developed here for $\text{Pr}(\text{overflow})$ are illustrated with examples in the next section that indicate their tightness.

2.2.2 Examples of the bounds on $\text{Pr}(\text{Overflow})$

Two examples of the use of the bounds on $\text{Pr}(\text{overflow})$ are given in this section. The first is a gradual input queue which is used to illustrate the general procedure.

The second is an M/M/1 queue which is presented to show how the upper bound compares with the exact value.

As a first example, consider a gradual input queue with three identical input channels. The on and off times on each channel are exponentially distributed with means $\mu^{-1}=1$ and $\lambda^{-1}=5$ respectively. This gives an output channel utilization of 0.5 if no traffic losses occur.

As described previously, the $\text{Pr}(\text{overflow})$ for this queue with buffer size K can be determined by considering an equivalent M/G/1 queue. The equivalent M/G/1 queue has an interarrival time distribution with Laplace transform

$$A^*(\theta) = \frac{3\lambda}{\theta+3\lambda} = \frac{0.6}{\theta+0.6}$$

This is the transform for the time between inflow periods. The transform for the equivalent service time is the same as the transform of $h-l$.

$$B^*(\theta) = H^*(\theta) = \frac{2\mu\theta^2 + (2\lambda\mu + 7\mu^2)\theta + 6\mu^3}{(2\mu + 4\lambda)\theta^2 + (4\lambda^2 + 2\lambda\mu + 7\mu^2)\theta + 6\mu^3}$$

$$= \frac{2\theta^2 + 7.4\theta + 6}{2.8\theta^2 + 8.76\theta + 6}$$

Now the problem is to find the exponent θ^* for the exponential bound. The exponent is the unique positive real solution to

$$f(\theta) = A^*(\theta)B^*(-\theta) = 1$$

which lies in an interval I_0 in which $f(\theta)$ is bounded. For the example considered here, this equation has three solutions, 0, 0.902 and 2.055. Of these, only 0.902 is positive real and in I_0 . The root 2.055 lies outside of I_0 because the function $B^*(-\theta)$ has a pole at 1.01. The uniqueness of θ^* is therefore as predicted by the Kingman theory. The bound is completed by finding

$$H^*(-\theta^*) = H^*(-0.902) = 2.503$$

Therefore

$$\text{Pr(overflow)} \leq \frac{2.503e^{-0.902K}}{1 - e^{-0.902K}}$$

where K is the buffer size. This bound is plotted in Figure 2.6. Notice that for small values of K the bound becomes large because of the denominator. Therefore another bound has been used in this region.

The bound used for small buffer sizes is the Pr(overflow) when $K=0$. For $K=0$ the following is true.

$$1 - \text{Pr(overflow)} = \text{Pr(First input channel goes off before a second one comes on)}$$

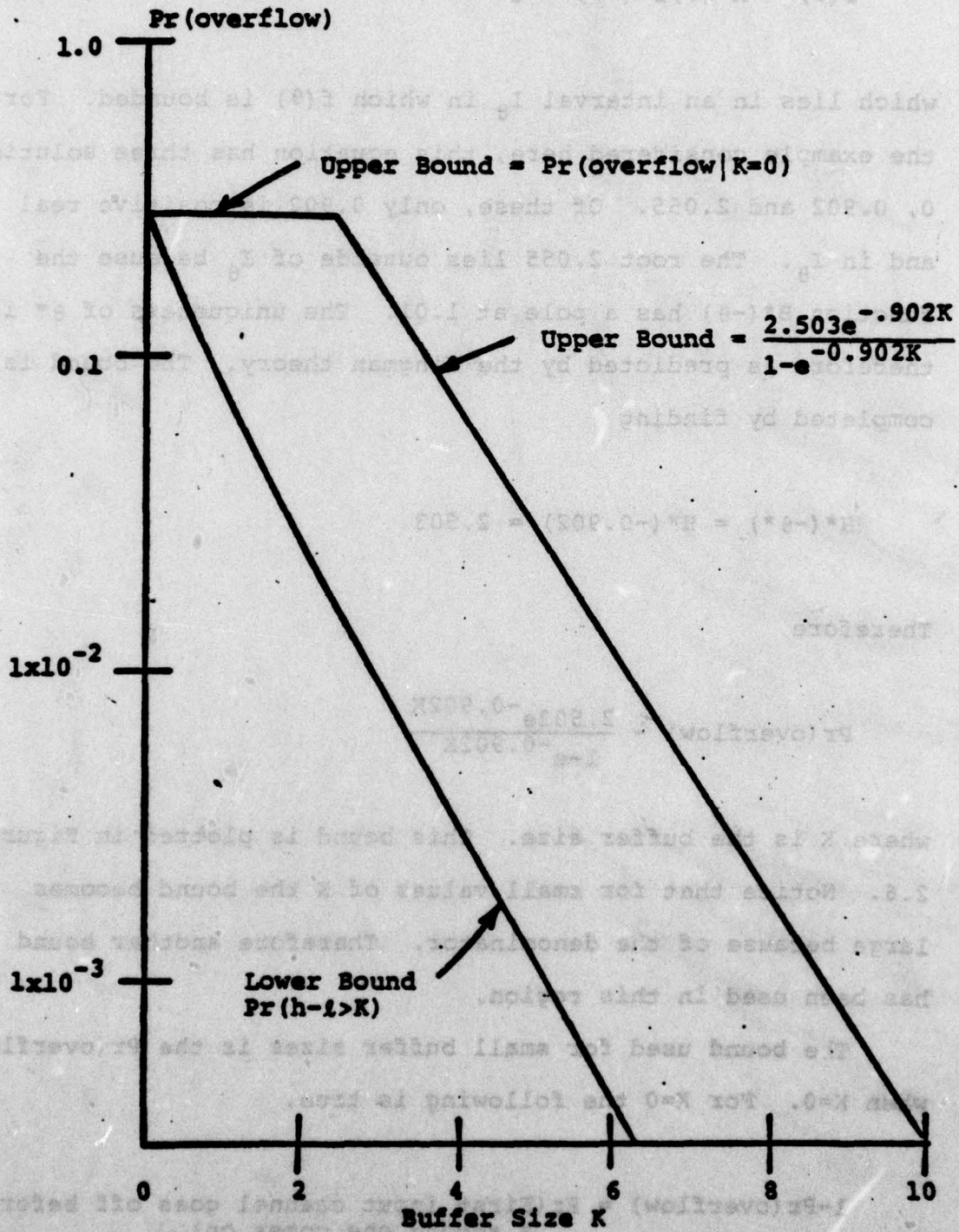

FIGURE 2.6 - Bounds on $\text{Pr}(\text{overflow})$ for a three input gradual input queue. All three inputs are identical with $\mu^{-1}=1$ and $\lambda^{-1}=5$.

$$= \int_{t=0}^{\infty} \text{Pr}(\text{on time} = t \text{ for channel}) (\text{Pr}(\text{off time} > t) \text{ for channel})^2 dt$$

$$= \int_{t=0}^{\infty} \mu e^{-\mu t} e^{-\lambda t} e^{-\lambda t} dt$$

$$= \frac{\mu}{\mu + 2\lambda} = \frac{1}{1.4} = 0.714$$

Clearly this exact solution for $K=0$ is an upper bound for $K>0$.

The lower bound to $\text{Pr}(\text{overflow})$ that was developed in the previous section is

$$\text{Pr}(\text{overflow}) \geq \text{Pr}(h-l > K)$$

In order to evaluate this bound, the transform $H^*(\theta)$ must be inverted. For this example

$$\begin{aligned} H^*(\theta) &= \frac{2\theta^2 + 7.4\theta + 6}{2.8\theta^2 + 8.76\theta + 6} \\ &= 0.714 + \frac{0.408\theta + 0.612}{(\theta + 1.013)(\theta + 2.116)} \end{aligned}$$

Therefore using standard inversion techniques, one obtains

$$H(t) = 0.714\delta(t) + (.178)(1.013)e^{-1.013t} + (.108)(2.116)e^{-2.116t} \quad t \geq 0$$

where $\delta(t) = 1$ if $t=0$
 $= 0$ otherwise

From this it is easy to find the bound.

$$\Pr(h-l > K) = \int_{t=K}^{\infty} H(t) dt = 0.178e^{-1.013K} + .108e^{-2.116K}$$

This bound is also shown in Figure 2.6.

As a second example, an M/M/1 queue will be considered. The M/M/1 queue is a limiting case of a gradual input queue. It is the case with infinite capacity input channels which allow instantaneous message arrival. This is discussed further in Section 2.3. Here the M/M/1 example is of interest because it can be used to compare the upper bound on Pr(overflow) with the exact solution.

Recall that

$$\Pr(\text{overflow}) = \frac{\Pr(w+y > K) - \Pr(w > K)}{1 - \Pr(w > K)}$$

For an M/M/1 queue with mean arrival rate λ and mean service time μ^{-1} , the service time y has distribution

$$\Pr(y \leq t) = \begin{cases} 1 - e^{-\mu t} & t > 0, \mu > 0 \\ 0 & t \leq 0 \end{cases}$$

The distribution of the actual waiting time w is [KLEIN 75]

$$\Pr(w \leq t) = 0 \quad t < 0$$

$$1 - \rho \quad t = 0$$

$$1 - \rho e^{-\mu(1-\rho)t} \quad t > 0$$

where $\rho = \lambda/\mu$

From this the required $\Pr(w > K)$ is easily found to be

$$\Pr(w > K) = 1 - \Pr(w \leq K) = \rho e^{-\mu(1-\rho)K} = \rho e^{(\lambda-\mu)K}; \quad K > 0$$

The $\Pr(w+y > K)$ can be obtained as follows.

$$\Pr(w+y > K) = \Pr(y > K) + \Pr(y < K \text{ and } w+y > K)$$

$$= e^{-\mu K} + \int_0^K \mu e^{-\mu t} \rho e^{-\mu(1-\rho)(K-t)} dt$$

$$= e^{(\lambda-\mu)K}; \quad K > 0$$

Therefore

$$\Pr(\text{overflow}) = \frac{(1-\rho)e^{(\lambda-\mu)K}}{1-\rho e^{(\lambda-\mu)K}} \quad K > 0$$

The upper bound for $\Pr(\text{overflow})$ given by Equation 2.18 is also easily found for the M/M/1 queue. The bounding exponent is determined using the equation

$$f(\theta) = A^*(\theta)B^*(-\theta) = \frac{\lambda}{\theta + \lambda} \frac{\mu}{-\theta + \mu} = 1$$

The solutions to this equation are 0 and $\mu - \lambda$. Therefore $\theta^* = \mu - \lambda$. The upper bound is then given by

$$\begin{aligned} \text{Pr(overflow)} &\leq \frac{B^*(-\theta^*)e^{-\theta^*K}}{1 - e^{-\theta^*K}} \\ &= \frac{(\mu/\lambda) e^{(\lambda - \mu)K}}{1 - e^{(\lambda - \mu)K}} \end{aligned}$$

In comparing the upper bound with the exact solution, it can be seen that the bound has the correct exponential behavior. Table 2.2 gives values of both the bound and the exact solution for different utilizations and buffer sizes. The table shows that the bound is loose for small buffer sizes. For larger buffer sizes and reasonably small probabilities of buffer overflow, however, the bound is fairly good. In this region the difference between the two is less than one order of magnitude.

TABLE 2.2

Pr(overflow) for the M/M/1 Queue

Mean message length = $\mu^{-1} = 1$

Utilization	Buffer Size (In mean message lengths)	Pr(overflow)	
		Exact	Upper Bound
0.2	2	0.1683	1.2648
0.2	4	3.2878×10^{-2}	0.2125
0.2	6	6.5946×10^{-3}	4.1490×10^{-2}
0.2	8	1.3297×10^{-3}	8.3216×10^{-3}
0.2	10	2.6839×10^{-4}	1.6779×10^{-3}
0.2	12	5.4184×10^{-5}	3.3867×10^{-4}
0.2	14	1.0939×10^{-5}	6.8372×10^{-5}
0.2	16		
0.5	2	0.2254	1.1640
0.5	4	7.2579×10^{-2}	0.3130
0.5	6	2.5529×10^{-2}	0.1048
0.5	8	9.2425×10^{-3}	3.7315×10^{-2}
0.5	10	3.3804×10^{-3}	1.3567×10^{-2}
0.5	12	1.2409×10^{-3}	4.9698×10^{-3}
0.5	14	4.5615×10^{-4}	1.8254×10^{-3}
0.5	16	1.6776×10^{-4}	6.7115×10^{-4}
0.8	2	0.2891	2.5416
0.8	4	0.1403	1.0200
0.8	6	7.9361×10^{-2}	0.5388
0.8	8	4.8158×10^{-2}	0.3162
0.8	10	3.0353×10^{-2}	0.1956
0.8	12	1.9563×10^{-2}	0.1247
0.8	14	1.2784×10^{-2}	8.0934×10^{-2}
0.8	16	8.4272×10^{-3}	5.3118×10^{-2}

2.2.3 A per unit time overflow measure

A per unit time overflow measure may be more useful than a probability of overflow per busy period in some applications. The following discussion shows how the upper bound on the probability of overflow per busy period developed in Section 2.2.1 can be converted to two different lower bounds on expected time to buffer overflow.

For the first bound, let $E\{T_0\}$ be the expected time to the first buffer overflow of a gradual input queue, starting from the beginning of a busy period. This expected time can be expressed as a sum of expected times to overflow that are conditioned on the busy period in which the overflow occurred, i.e.,

$$E\{T_0\} = \sum_{i=1}^{\infty} E\{T_0 | bp_{\text{overflow}} = i\} \Pr(bp_{\text{overflow}} = i) \quad (\text{Eq. 2.20})$$

Now each term in this equation will be examined.

First consider the conditional expected times $E\{T_0 | bp_{\text{overflow}} = i\}$. Figure 2.7a illustrates the sequence of idle and busy periods that precede an overflow in the i th busy period. From the figure it is easy to see that

$$E\{T_0 | bp_{\text{overflow}} = i\} = (i-1) [E\{T_{\text{bpno}}\} + E\{T_{\text{idle}}\}] + E\{T_{\text{bpo}}\}$$

$$i = 1, 2, 3, \dots$$

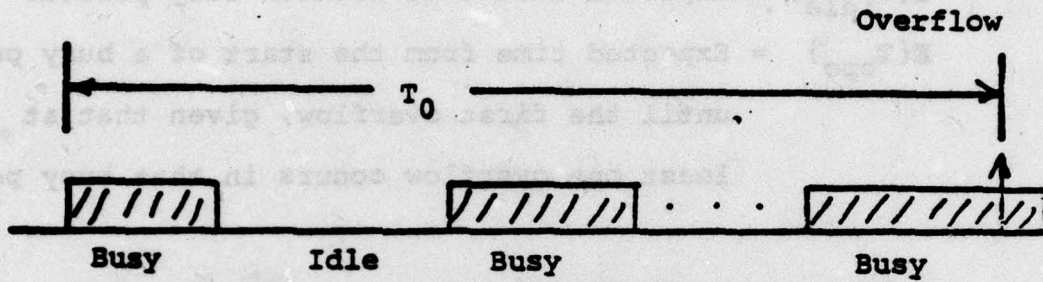

a. Definition of T_0

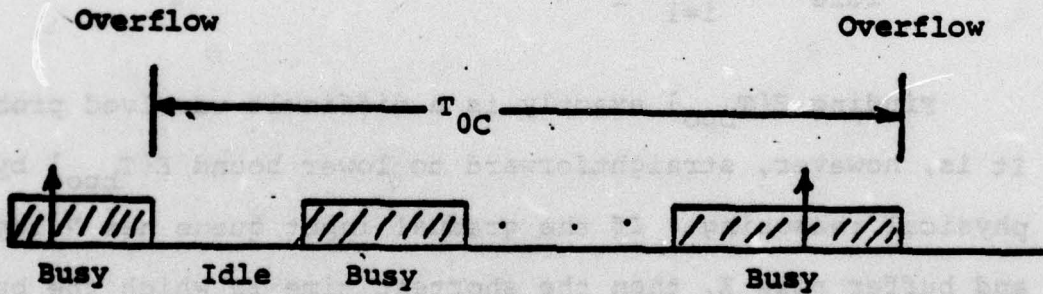

b. Definition of T_{0C}

FIGURE 2.7 - Definitions of times between overflows

where

$E\{T_{bpno}\}$ = Expected length of a busy period in which no overflow occurs

$E\{T_{idle}\}$ = Expected idle time between busy periods

$E\{T_{bpo}\}$ = Expected time from the start of a busy period until the first overflow, given that at least one overflow occurs in that busy period

As discussed in Section 2.1.1, the off times on all input channels of a gradual input queue are taken to be exponentially distributed. Therefore if there are N input channels with mean off times λ_i^{-1} ($i=1,2,\dots,N$), then

$$E\{T_{idle}\} = \left[\sum_{i=1}^N \lambda_i \right]^{-1}$$

Finding $E\{T_{bpo}\}$ exactly is a difficult unsolved problem. It is, however, straightforward to lower bound $E\{T_{bpo}\}$ by physical reasoning. If the gradual input queue has N inputs and buffer size K , then the shortest time in which the buffer can be filled is $K/(N-1)$. Here, as elsewhere in this study, it is assumed that the communication channels associated with the queue all operate at a rate = 1.

Determining $E\{T_{bpno}\}$ exactly is another difficult problem. Again, however, a simple lower bound can be found by physical reasoning. For a gradual input queue with a

finite buffer, a busy period consists of at least one complete message (on time on an input channel), whether or not there is overflow during the busy period. Therefore if the mean length of an on time on an input channel is μ^{-1} then

$$E\{T_{bpno}\} \geq \mu^{-1}$$

Now consider the terms $\Pr\{bp_{overflow} = i\}$. By noting that busy periods of a queue are independent, it follows that

$$\Pr\{bp_{overflow} = i\} = (1-P_0)^{i-1} P_0 \quad i = 1, 2, \dots$$

where P_0 is the probability of buffer overflow in one busy period. Combining this with the previous analysis of $E\{T_0 | bp_{overflow} = i\}$ gives

$$\begin{aligned} E\{T_0\} &= \sum_{i=1}^{\infty} [(i-1)[E\{T_{bpno}\} + E\{T_{idle}\}] + E\{T_{bpo}\}] (1-P_0)^{i-1} P_0 \\ &= [E\{T_{bpno}\} + E\{T_{idle}\}] \left(\frac{1-P_0}{P_0}\right) + E\{T_{bpo}\} \\ &\geq (\mu^{-1} + (\sum_{i=1}^N \lambda_i)^{-1}) \left(\frac{1-P_0}{P_0}\right) + K/(N-1) \end{aligned}$$

The bound for $E\{T_0\}$ still involves the probability P_0 which is difficult to evaluate exactly. This difficulty can be

overcome by applying the upper bound for P_0 derived in Section 2.1.1. Denote this upper bound by P_U . Then $P_U \geq P_0$ and therefore

$$1 - P_U \leq 1 - P_0$$

and

$$\frac{1 - P_U}{P_U} \leq \frac{1 - P_0}{P_0}$$

and therefore

$$E\{T_0\} \geq (\mu^{-1} + (\sum_{i=1}^N \lambda_i)^{-1}) \left(\frac{1 - P_U}{P_U}\right) + K/(N-1) \quad (\text{Eq. 2.21})$$

As an example of the use of this bound, consider a two input gradual input queue with buffer size K . Let the mean on and off times on both channels be $\mu^{-1} = 1$ and $\lambda^{-1} = 3$ respectively.

The first step in bounding $E\{T_0\}$ is to bound P_0 . The upper bound for P_0 developed in Section 2.1.1 is

$$P_0 \leq P_U = \frac{H^*(-\theta^*)e^{-\theta^*K}}{1 - e^{-\theta^*K}}$$

For this example $\theta^* = 1.34$ and $H^*(-\theta^*) = 3$. The expected time $E\{T_{\text{idle}}\} = (\sum_{i=1}^N \lambda_i)^{-1} = (.667)^{-1} = 1.5$ while the expected time $E\{T_{\text{bpno}}\} \geq \mu^{-1} = 1$. Therefore

$$E\{T_0\} \geq 2.5 \frac{(1-P_U)}{P_U} + K$$

Table 2.3 gives the value of this bound for three different buffer sizes.

TABLE 2.3

Lower Bound on $E\{T_0\}$ for a Two Input Gradual Input Queue
 Input Mean on Time = 1
 Input Mean off Time = 3

Buffer size (1 unit = 1 mean input on time)	Upper bound on Pr(overflow)	Lower bound on $E\{T_0\}$
5	3.82×10^{-3}	6.56×10^2
10	4.85×10^{-6}	5.15×10^5
15	6.18×10^{-9}	4.05×10^8

A second bound for an expected time to buffer overflow will now be developed. Let T_{0C} be the time between the end of a busy period in which there was an overflow and the end of the next busy period in which there is another overflow, i.e. the time for one overflow cycle. Then T_{0C} represents the length of a renewal event that contains exactly one busy period in which there is buffer overflow. This is illustrated in Figure 2.7b.

Now consider a sequence of M busy periods of a gradual input queue with a finite buffer. The expected number of busy periods in which there is at least one overflow is then $M \Pr(\text{overflow}) = M P_0$. Therefore as $M \rightarrow \infty$, the expected total time in which the M busy periods occur is given by

$$E\{T_{\text{total}}\} = M P_0 E\{T_{0C}\}$$

or

$$E\{T_{0C}\} = \frac{E\{\text{total}\}}{M P_0} \quad (\text{Eq. 2.22})$$

Now in order to lower bound $E\{T_{0C}\}$, an upper bound, P_U , for P_0 can be used as before. The remaining problem is to lower bound $E\{T_{\text{total}}\}$ for the finite buffer.

M busy cycles occur in the time $E\{T_{\text{total}}\}$. Each busy cycle includes a busy period and an idle period. Therefore

$$E\{T_{\text{total}}\} = M[E\{T_{\text{bp}}\} + E\{T_{\text{idle}}\}]$$

The time $E\{T_{\text{idle}}\}$ is easy to find as discussed previously and $E\{T_{\text{bp}}\}$ can be lower bounded by μ^{-1} as was done for $E\{T_{\text{bpno}}\}$. This gives the following lower bound

$$E\{T_{OC}\} \geq \frac{\mu^{-1} + (\sum_{i=1}^N \lambda_i)^{-1}}{P_U} \quad (\text{Eq. 2.23})$$

Note that this is very similar to Equation 2.21.

The bound in Equation 2.23 can be improved by obtaining a better lower bound for $E\{T_{total}\}$. This can be done by first considering the time required for M busy cycles of a gradual input queue with an infinite buffer. The total time will be

$$E\{T_{total}\}_{infinite} = M\{E\{T_{bp}\}_{infinite} + E\{T_{idle}\}$$

The time $E\{T_{idle}\}$ is the same as before and $E\{T_{bp}\}_{infinite}$ is a standard result for an $M/G/1$ queue that follows from the analogy discussed in Section 2.1.1. Therefore

$E\{T_{total}\}_{infinite}$ can be calculated exactly.

Now note that a gradual input queue with a finite buffer has the same busy periods as a queue with an infinite buffer, except when there are overflows. Therefore, the expected total time for M busy cycles for the finite buffer is

$$E\{T_{total}\} = E\{T_{total}\}_{infinite} - M P_0 E\{T_{lost}\}$$

where $E\{T_{lost}\}$ is the expected length by which busy periods with overflows are shortened due to the overflows. Using Equation 2.22 again gives

$$E\{T_{OC}\} = \frac{E\{T_{bp}\}_{infinite} + E\{T_{idle}\} - P_0 E\{T_{lost}\}}{P_0}$$

$$\geq \frac{E\{T_{bp}\}_{infinite} + E\{T_{idle}\} - P_U E\{T_{lost}\}}{P_U} \quad (\text{Eq. 2.24})$$

Unfortunately, $E\{T_{lost}\}$ cannot be easily upper bounded. However, as $P_U \rightarrow 0$, this is not important because then $P_U E\{T_{lost}\}$ also $\rightarrow 0$. Setting $P_U E\{T_{lost}\}$ to zero therefore gives accurate results if P_U is small. Results obtained by using Equations 2.23 and 2.24 for the two input example considered previously in this section are given in Table 2.4.

TABLE 2.4

Lower Bounds on $E\{T_{OC}\}$ for a Two Input Gradual Input Queue

Input Mean on Time = 1

Input Mean off Time = 3

Buffer size (1 unit = 1 mean input on time)	Upper bound on Pr(overflow)	Lower bound on $E\{T_{OC}\}$ (Eq. 2.23)	Lower bound on $E\{T_{OC}\}$ (Eq. 2.24) with $P_U E\{T_{lost}\}$ = 0
5	3.82×10^{-3}	6.54×10^2	7.85×10^2
10	4.85×10^{-6}	5.15×10^5	6.19×10^5
15	6.18×10^{-9}	4.05×10^8	4.85×10^8

2.2.4 Other overflow measures

It is of interest to obtain more detailed overflow statistics than just the probability of at least one overflow event in a busy period. One statistic that is of interest is the probability of another overflow in a busy period, given that there has already been at least one in that busy period. This probability can easily be bounded if one considers a sample function of buffer content that shows a buffer overflow. Such a sample function is depicted in Figure 2.8. As shown, a buffer overflow event always ends with all sources being off. A simple bound on the probability of there being another overflow in the same busy period is therefore given by

$$\Pr(\text{overflow again in this busy period} \mid \text{overflow has occurred}) < 1 - \Pr(\text{no sources come on in the first } K \text{ time units after previous overflow})$$

$$1 - e^{-\Lambda K}$$

$$\text{where } \Lambda = \sum_{i=1}^N \lambda_i$$

Clearly, if no sources come on in the first K time units after the previous overflow, the buffer will empty and there will not be another overflow in this busy period. This is only an upper bound, however, because even if a source comes

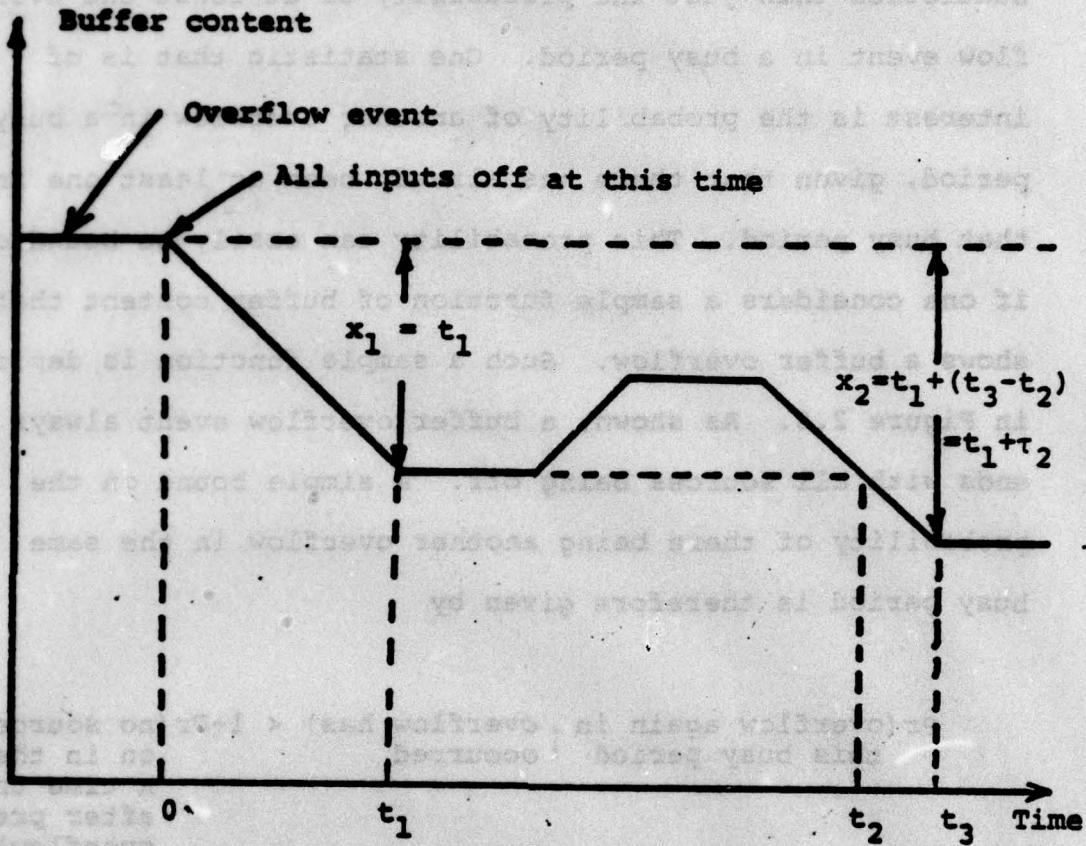

FIGURE 2.8 - Sample function of buffer content after an overflow in a gradual input queue. Capacity of all input channels and the output channel is one unit of data/unit time.

on in the first K time units, that inflow period need not cause buffer overflow. This is a very simple bound that is weak if the buffer size, K , is large. Therefore it is worthwhile to improve it.

The improvement of the upper bound for the probability of another overflow also follows from Figure 2.8. Assume that a source comes on at time t_1 . Now note that from t_1 until t_2 , the buffer content stays above $K-x_1$. The behavior of the buffer content above $K-x_1$ during this period is the same as the behavior of the buffer content during a busy period for a gradual input queue with buffer size x_1 . Since $x_1 = t_1$, it follows that

Pr(overflow again in this busy period | overflow has occurred)

$$< 1 - \text{Pr}(\text{no sources come on in the first } K \text{ time units after previous overflow})$$

$$= 1 - \int_{t_1=0}^K \lambda e^{-\lambda t_1} \text{Pr}(\text{overflow in buffer busy period size}=t_1) dt_1$$

$$= 1 - e^{-\lambda K}$$

$$= 1 - \int_{t_1=0}^K \lambda e^{-\lambda t_1} \text{Pr}(\text{overflow in buffer busy period size}=t_1) dt_1$$

Now a lower bound for $\text{Pr}(\text{overflow})$, (such as Equation 2.19), can be used in Equation 2.25 to complete the upper bound. Equation 2.25 is an upper bound because after t_2 , there could be the start of another inflow period during which the buffer could overflow. The next inflow period after t_2 can be thought of as starting a busy period for a queue with buffer size x_2 . By recognizing this pattern, it is possible to improve the bound given in Equation 2.25 by considering the possibility of more than one inflow period occurring in the remaining busy period. The above bounding idea will be used in Chapter 4 to study flow control problems.

It is also of interest to obtain the distribution of the quantity of data that is lost in an overflow event. This can be done for two input gradual input queues by developing a continuous time Markov chain that represents the overflow event. For example, consider the queue shown in Figure 2.9a. When an overflow event starts, both inputs must be on. The buffer content then remains at its maximum level K until both inputs are off for the first time. During the overflow event, data is lost whenever both inputs are on. The Markov chain in Figure 2.9b represents this overflow process. The distribution of the amount of data lost is the distribution of the time spent in state 1 of the chain before trapping in state 4, given that the starting state is 1.

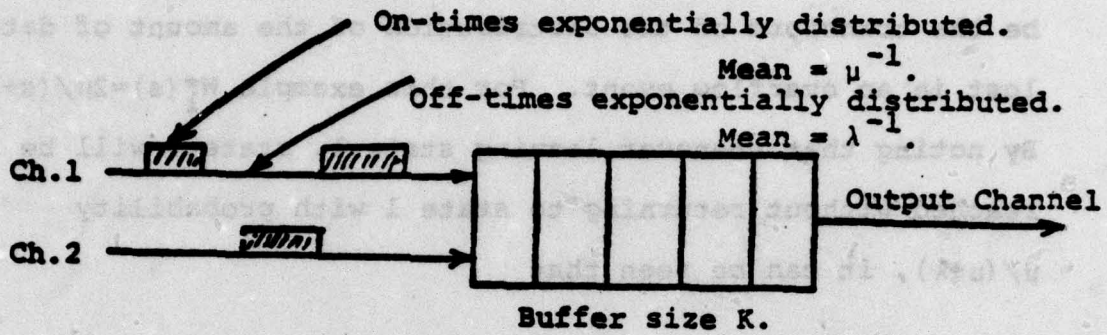

a. Two input example.

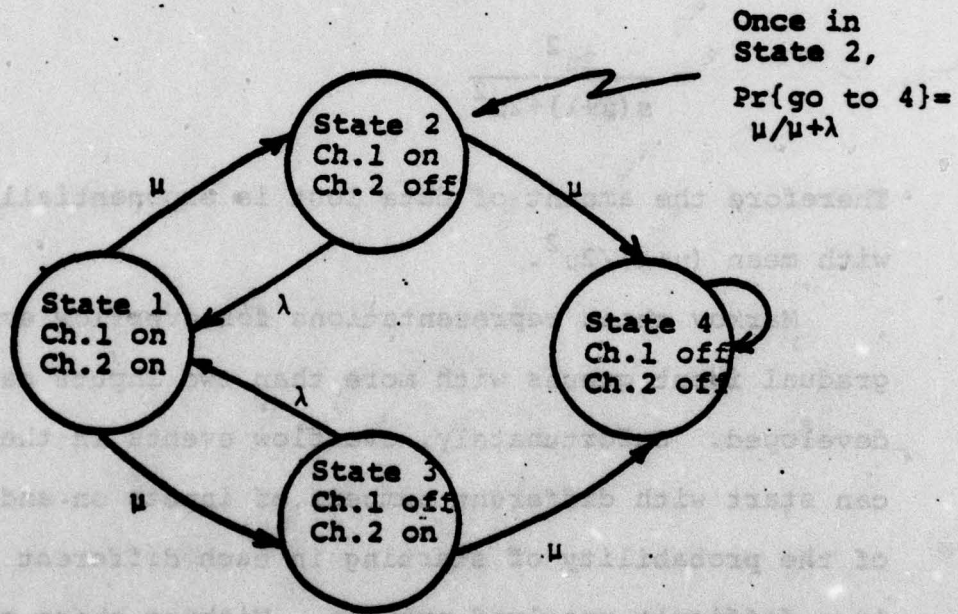

b. Markov chain representation of the overflow event.

FIGURE 2.9 - Obtaining the distribution of the quantity of data lost in an overflow event.

Let $W_1^*(s)$ be the Laplace transform of the time spent in state 1 during one visit to that state. Similarly, let $L^*(s)$ be the transform of the distribution of the amount of data lost in an overflow event. For this example $W_1^*(s) = 2\mu / (s + 2\mu)$. By noting that whenever leaving state 1, state 4 will be reached without returning to state 1 with probability $\mu / (\mu + \lambda)$, it can be seen that

$$\begin{aligned} L^*(s) &= \sum_{i=0}^{\infty} W_1^*(s)^{i+1} \left(\frac{\mu}{\mu+\lambda}\right) \left(1 - \frac{\mu}{\mu+\lambda}\right)^i \\ &= \frac{2\mu}{s+2\mu} \left(\frac{\mu}{\mu+\lambda}\right) \sum_{i=0}^{\infty} \left(\frac{2\mu}{s+2\mu}\right)^i \left(\frac{\lambda}{\mu+\lambda}\right)^i \\ &= \frac{2\mu^2}{s(\mu+\lambda) + 2\mu^2} \end{aligned}$$

Therefore the amount of data lost is exponentially distributed with mean $(\mu + \lambda) / 2\mu^2$.

Markov chain representations for overflow events of gradual input queues with more than two inputs can also be developed. Unfortunately, overflow events in these queues can start with different numbers of inputs on and determination of the probability of starting in each different input state is a difficult unsolved problem. Without these starting probabilities the Markov chain representations cannot be used to determine the distribution of the amount of data lost in an overflow event. Of course one can upper bound

the loss by assuming the maximum number of inputs on, but this may not be a very tight bound.

2.3 Comparison of the Gradual Input Queue and the M/M/1 Queue

The gradual input queue accounts for a finite input rate and a finite number of sources while the M/M/1 queue does not. This section discusses the single stage queueing effects that this allows one to observe that cannot be seen using the M/M/1 queue.

Perhaps the clearest picture of the differences between the two queueing models can be obtained by examining the expected maximum buffer content during a busy period, $E[V_{\max}]$, for queues with infinite buffers. Figure 2.10 shows $E[V_{\max}]$ for the M/M/1 queue and several gradual input queues. In this figure, three differences between the two types of queues can be observed. These are denoted by D_1 , D_2 , and D_3 on the graph.

The first difference, D_1 , is the difference between an M/M/1 queue and a gradual input queue with an infinite number of input channels. The difference D_1 is equal to the mean length of one message. This results from the difference between instantaneous input (the M/M/1 queue) and gradual input. This difference, as well as D_2 and D_3 , is independent of the on time distribution for the gradual input queue.

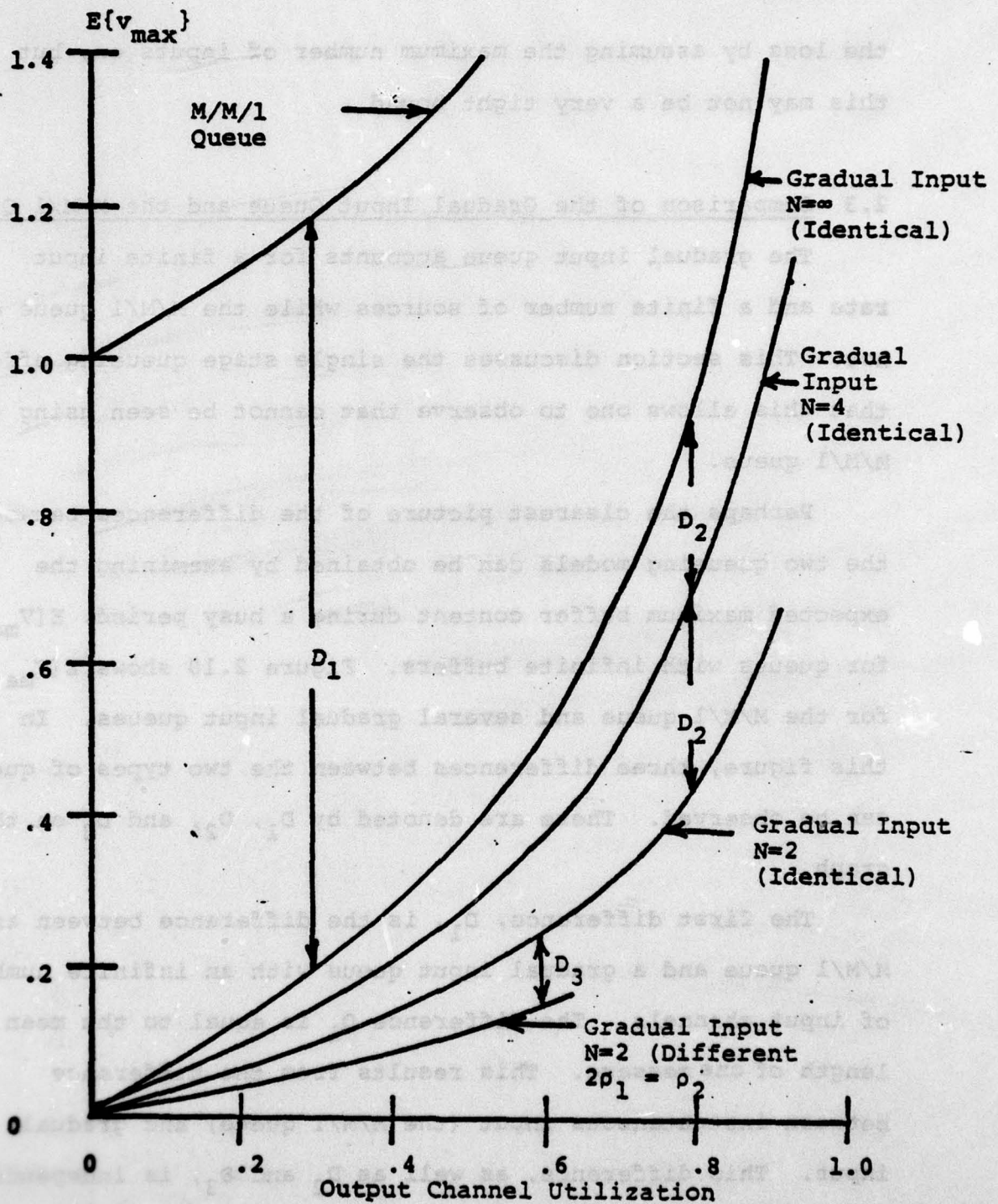

FIGURE 2.10 - $E\{v_{\max}\}$ for several queues. All input channels have an expected on time = 1.

The differences D_2 represent the changes in queueing with different numbers of input channels. As the graph shows, the fewer input channels there are, the less the queueing. This is because, with a finite number of input channels, when some of them are on, there is less remaining traffic intensity. The remaining traffic intensity referred to here is the rate at which additional inputs can come on and add to the buffer. When there are a large number of channels, having a few of them on does not decrease the remaining traffic intensity much. However, if there are few inputs to begin with, having some of them on can greatly reduce this traffic intensity. Another way of thinking about this phenomenon is that the finite rate channels tend to reduce the burstiness of the data arrival process and the fewer input channels there are, the more the burstiness is reduced. This effect cannot be seen using the M/M/1 queue.

Another phenomenon that can be seen with the gradual input queue is the effect of unequal traffic on the input channels. The greatest queueing occurs when all channels carry the same amount of traffic. If they carry different amounts of traffic, the queueing is reduced as shown by difference D_3 . This is easy to understand when one remembers that if all the traffic were on one input channel, there would be no queueing at all. Again this effect cannot be seen using the simpler M/M/1 queue.

The effects discussed above can also be seen in other performance measures. Figure 2.11 shows the effect of different numbers of input channels on the upper bound for $Pr(\text{overflow})$. The same upper bound is also given for the M/M/1 queue as a reference. Again, the amount of queueing increases with the number of input channels.

Figure 2.12 shows a graph of the expected delay per bit for the M/M/1 queue and bounds on this delay for a two input gradual input queue. The gradual input queue has less delay than the M/M/1 queue. Note that at low utilizations the gradual input queue has essentially no delay. This is because in this region of operation, nearly all busy periods consist of one input channel on period which flows through the queue with no buffer buildup. The M/M/1 queue with its instantaneous input, however, always has at least 0.5 message lengths of expected delay per bit.

Finally, Figure 2.13 compares $E[V_{\max}]$ for two input gradual input queues with several different input capacities with $E[V_{\max}]$ for an M/M/1 queue. As the input capacity of the two input queue is increased, the expected buffer buildup also increases. In the limit of infinite input capacities, the two input queue behaves the same as the M/M/1 queue because then the effects due to finite input rates no longer exist.

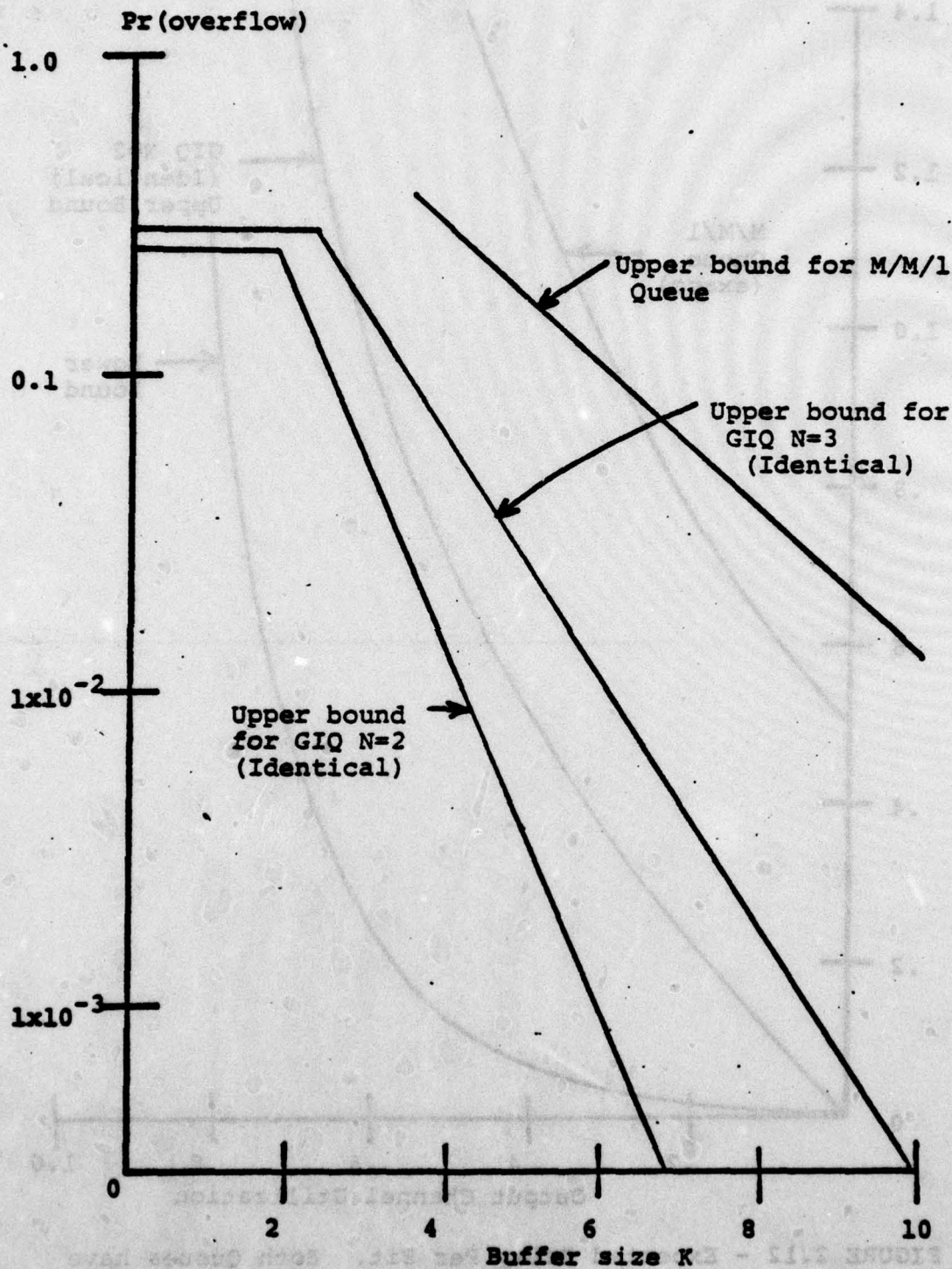

FIGURE 2.11 - Bounds on Pr(overflow). Mean on time for input channels=1. Queue utilization=0.5.

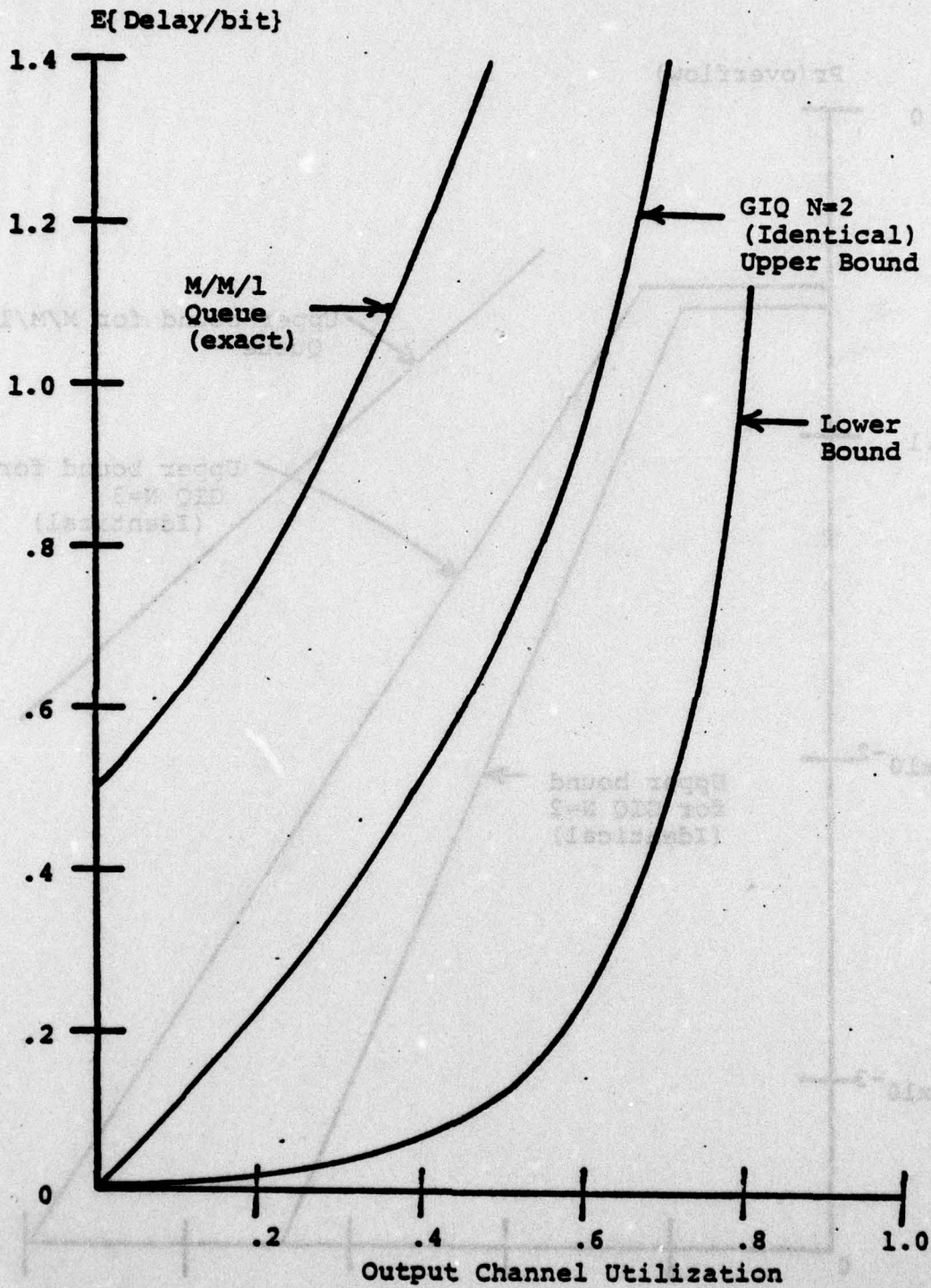

FIGURE 2.12 - Expected Delay Per Bit. Both Queues have mean input on times, $\mu^{-1} = 1$.

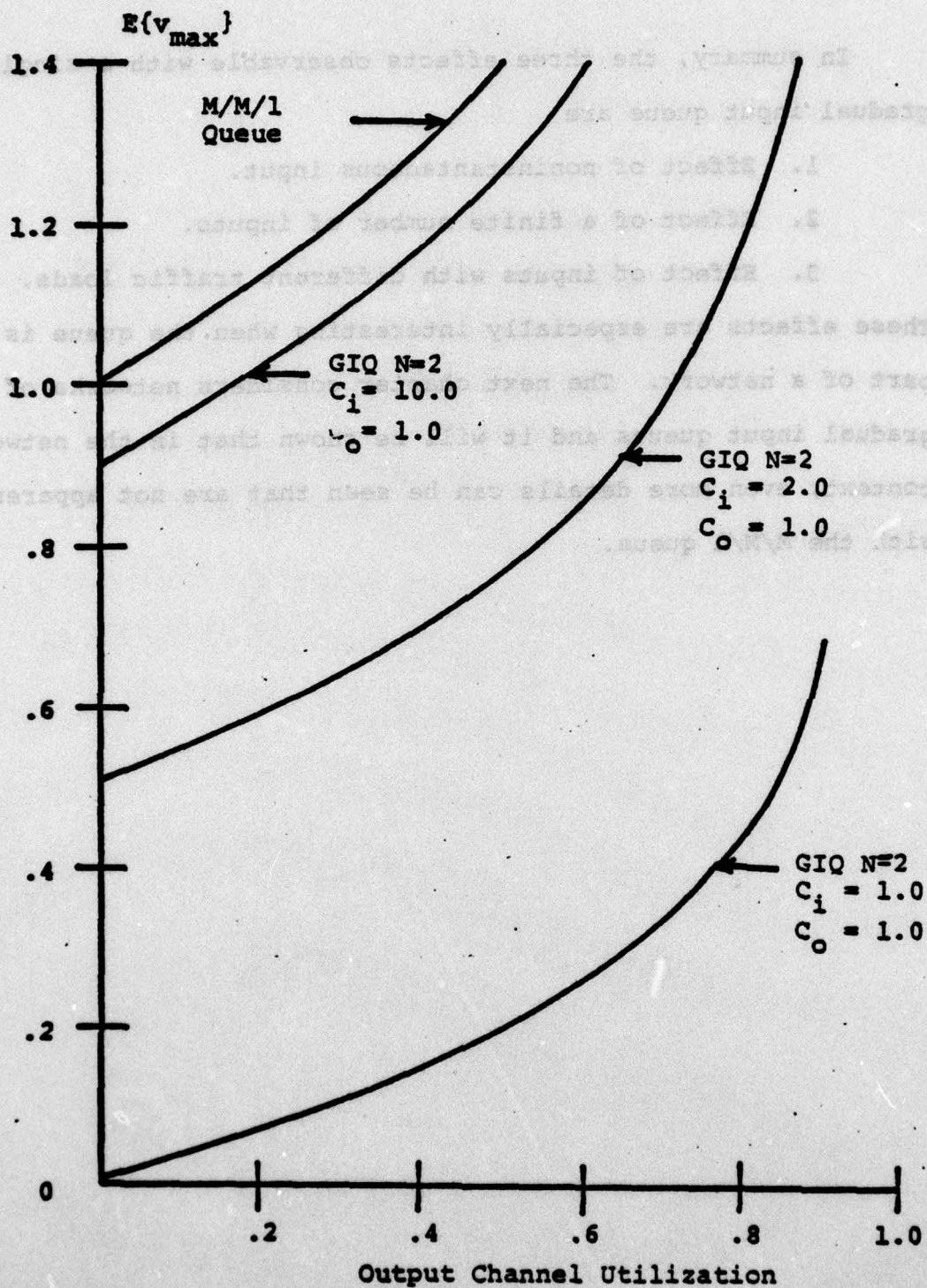

FIGURE 2.13 - $E[v_{\max}]$ for different input channel capacities. All input on times are scaled so that the expected length of an input = 1 unit of time on the output channel.

In summary, the three effects observable with a single gradual input queue are

1. Effect of noninstantaneous input.
2. Effect of a finite number of inputs.
3. Effect of inputs with different traffic loads.

These effects are especially interesting when the queue is part of a network. The next chapter considers networks of gradual input queues and it will be shown that in the network context, even more details can be seen that are not apparent with the M/M/1 queue.

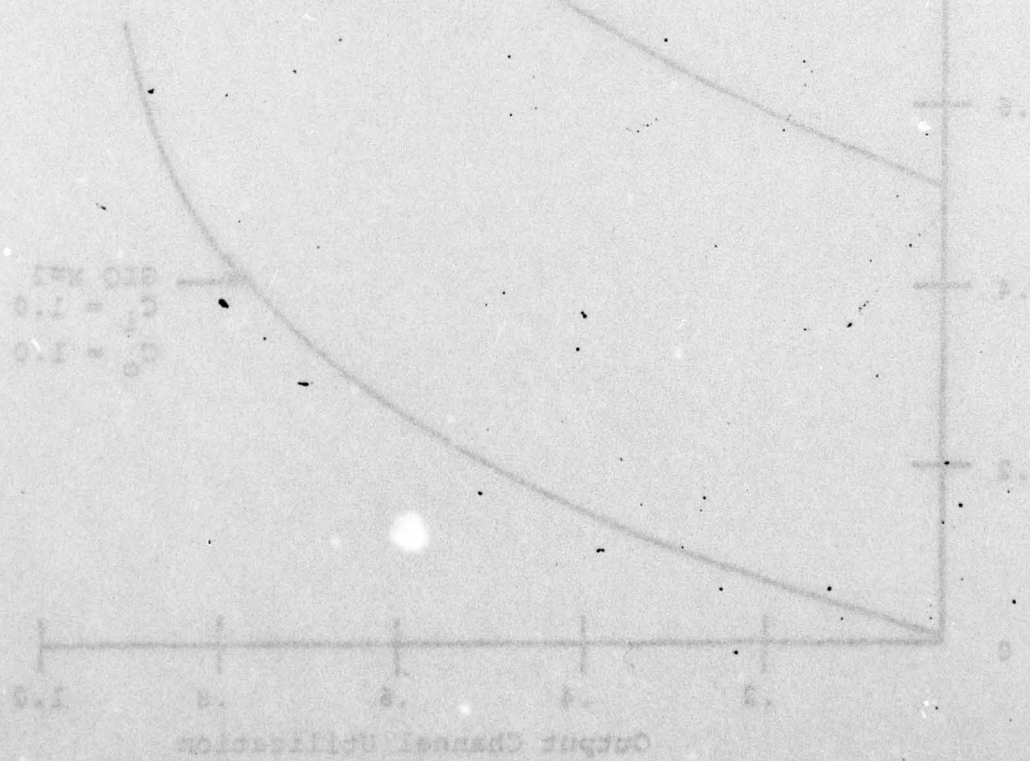

FIGURE 2.13 - $E[V_{max}]$ for different input channel capacities. All inputs in order are scaled so that the expected load of an input = 1 unit of time in the output channel.

CHAPTER III - NETWORKS OF GRADUAL INPUT QUEUES

This chapter deals with the analysis of buffering requirements in a network of gradual input queues. The network of queues represents a message switched communication network in which static routing is being used. The required analysis cannot be done exactly, so the approximations used are first presented. Several network examples are then given. The examples illustrate the special insights into network operation that can be obtained using the gradual input model. Finally, the problem of optimizing the static routing is briefly discussed.

3.1 Approximations for the Analysis of a General Network

3.1.1 Traffic streams in general networks

The gradual input queue representation of a message switched communication network consists of several basic elements. These include the network topology, the stochastic description of the input traffic, the routing policy and any other mechanisms such as flow control rules. Figure 3.1 illustrates these elements. The network topology consists of directed communication channels which interconnect a set of nodes. In this chapter, the communication capacities of all channels will be assumed to be identical and normalized to 1. Having identical channel capacities allows one to apply the analysis for a single stage developed in Chapter 2.

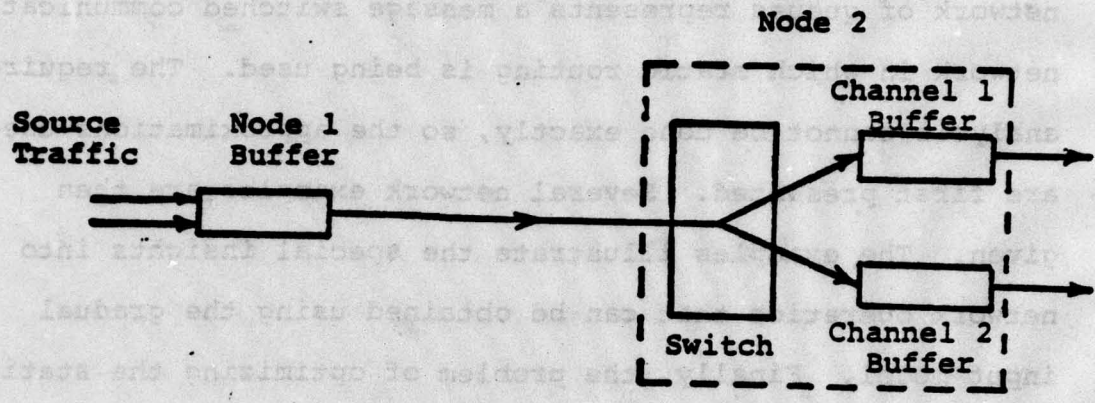

a. A simple network of gradual input queues.

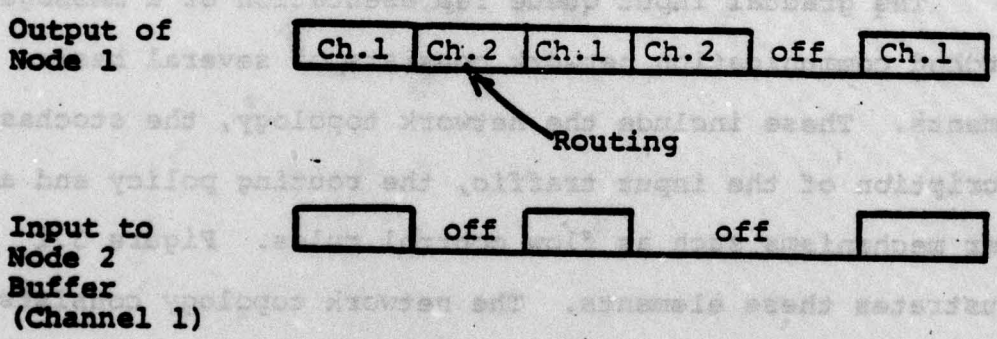

b. Typical Switched traffic sequence.

FIGURE 3.1 - Traffic streams in a network of queues.

The input traffic to the network also arrives on channels of capacity 1. This traffic is in the form of alternating renewal processes and the mean on time for all inputs will be taken to be equal to $\beta_{in} = \mu^{-1}$. An on time on an input channel represents one message and this message will be kept intact as it passes through the network. The path that the message takes is determined by the routing policy. The routing policy considered here is a static policy which routes fixed fractions of the traffic between any source and destination over specific paths. This is implemented by random sampling at the switching points with the sampling probabilities being the fixed fractions in the routing policy. Such a routing policy is the same as the one introduced by Kleinrock [KLEIN 64] in his study using a network of M/M/1 queues. The final network element, flow control mechanisms, will not be used in this chapter. It will be assumed that the traffic is allowed to flow freely through the network with no controls to reduce or distribute congestion. The goal of this chapter is to analyze the buffering requirements for a network such as described above, subject to a probability of buffer overflow constraint.

In Chapter 2 it was pointed out that the analysis currently available for gradual input queues requires that the traffic on the input channels be independent alternating renewal processes with exponentially distributed off times.

This requirement can easily be met by assumption for input channels which carry traffic directly from sources outside the network. Inside the network, however, this requirement cannot be met in general. First, traffic on 2 different internal buffer input channels may be correlated because it previously passed over a common channel. For this to happen, however, the traffic must have passed through at least one intermediate node since it was on a common channel. Therefore some of the correlation will be reduced. Here it will be assumed that all traffic streams are independent.†

The exponential off time requirement also cannot be met in general. An example that illustrates this is the small network shown in Figure 3.1a. The traffic into the node 2 buffers does not consist of alternating renewal processes with exponential off times. This is because of the routing done by the switch. The off times in the traffic streams after the switch are no longer exponential and independent of all other on and off periods because some of the off periods are caused by the removal of messages from the busy period of the previous stage. This is illustrated in Figure 3.1b.

The above difficulty relating to internal traffic streams will be dealt with by using an approximation. All traffic from external sources will be taken to have both on

†See Section 1.2 for a discussion of how this relates to the Kleinrock [KLEIN 64] independence assumption.

and off times exponentially distributed. Then it will be assumed that all traffic streams in the network are therefore alternating renewal processes with exponential on and off times. The use of this approximation is supported both by two limiting cases discussed below in which the approximation becomes exact, and by the simulation results given in Section 3.1.4.

The first limiting case in which traffic streams in a general network approach alternating renewal processes with exponentially distributed on and off times is when the utilization of the output channels of all buffer stages is near zero. This can be shown by first considering a buffer stage at which none of the input traffic has been switched (sampled). Since the output channel utilization is near zero, all busy periods on that channel will, with high probability, involve only one message. Therefore, with high probability, the traffic streams on the output channel will consist of an alternating renewal process of the form shown in Figure 3.2a. The exponential off times in this stream follow from the assumption that none of the input streams to this stage were switched.

Now note that when a stream of the form shown in Figure 3.2a is sampled, the resulting traffic stream again has on periods that consist of only one message. Therefore, if the length of a message is exponentially distributed, the

and all times exponentially distributed. Then it will be assumed that all traffic streams in the network are characterized by alternating renewal processes with exponential on and off times. The use of this approximation is suggested both by two limiting cases discussed below in which the approximation

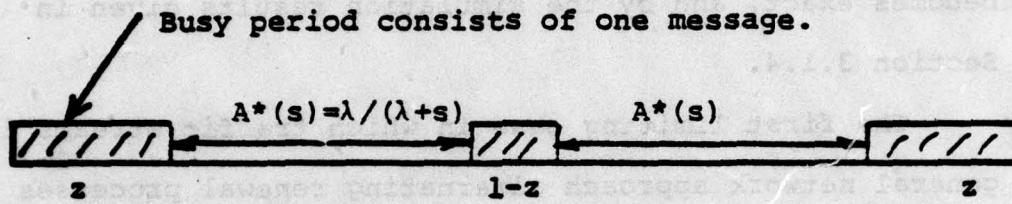

a. Unsampled message stream.

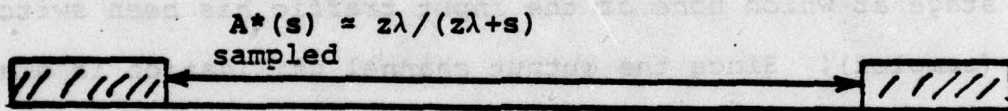

b. Sampled message stream.

FIGURE 3.2 - Traffic streams in a network with utilization near zero.

distribution of the on times of the sampled stream will approach an exponential when the utilization of all channels is near zero. The remaining problem is to determine the distribution of the off time periods in the sampled stream. This can be done as follows. Let $B^*(s) = u/(u+s)$ be the Laplace transform of the length of a single message and $A^*(s) = \lambda/(\lambda+s)$ be the Laplace transform of the length of an off-time in the unsampled stream. The traffic stream is sampled at random with a probability z of keeping a message in the stream of interest. Therefore the Laplace transform of the off-time distribution for the sampled stream is given by

$$\begin{aligned}
 A^*(s)_{\text{sampled}} &= \sum_{n=1}^{\infty} z(1-z)^{n-1} (A^*(s))^n (B^*(s))^{n-1} \\
 &= \sum_{n=1}^{\infty} z(1-z)^{n-1} (\lambda/(\lambda+s))^n (u/(u+s))^{n-1} \\
 &= \frac{z(\lambda/(\lambda+s))}{1-(1-z)(\lambda/(\lambda+s))(u/(u+s))} \quad s > \min\{-\lambda, -u\}
 \end{aligned}$$

(Eq.3.1)

The condition that the utilization factor on the output channel be near zero implies that $\lambda^{-1} \gg u^{-1}$. Therefore Equation 3.1 can be approximated by

$$\begin{aligned}
 A^*(s)_{\text{sampled}} &= \frac{z(\lambda/(\lambda+s))}{1-(1-z)(\lambda/(\lambda+s))} \\
 &= \frac{z\lambda}{z\lambda+s}
 \end{aligned}$$

(Eq.3.2)

distribution of the on times of the sampled stream will approach an exponential when the utilization of all channels is near zero. The remaining problem is to determine the distribution of the off time periods in the sampled stream. This can be done as follows. Let $B^*(s) = u/(u+s)$ be the Laplace transform of the length of a single message and $A^*(s) = \lambda/(\lambda+s)$ be the Laplace transform of the length of an off-time in the unsampled stream. The traffic stream is sampled at random with a probability z of keeping a message in the stream of interest. Therefore the Laplace transform of the off-time distribution for the sampled stream is given by

$$\begin{aligned}
 A^*(s)_{\text{sampled}} &= \sum_{n=1}^{\infty} z(1-z)^{n-1} (A^*(s))^n (B^*(s))^{n-1} \\
 &= \sum_{n=1}^{\infty} z(1-z)^{n-1} (\lambda/(\lambda+s))^n (u/(u+s))^{n-1} \\
 &= \frac{z(\lambda/(\lambda+s))}{1-(1-z)(\lambda/(\lambda+s))(u/(u+s))} \quad s > \min\{-\lambda, -u\}
 \end{aligned}$$

(Eq.3.1)

The condition that the utilization factor on the output channel be near zero implies that $\lambda^{-1} \gg u^{-1}$. Therefore Equation 3.1 can be approximated by

$$\begin{aligned}
 A^*(s)_{\text{sampled}} &= \frac{z(\lambda/(\lambda+s))}{1-(1-z)(\lambda/(\lambda+s))} \\
 &= \frac{z\lambda}{z\lambda+s}
 \end{aligned}$$

(Eq.3.2)

This states that the distribution of off times is approximately exponential at utilizations near zero. Therefore, proceeding step by step through a network, starting with stages whose inputs are not switched, one can show that at each stage the distribution of off times approaches an exponential distribution.

The second case that gives exponential off times is when the utilization factor of all stages in the network is near one. In this case, the output traffic streams are dominated by long busy periods consisting of many individual messages. This is shown in Figure 3.3a. The sampled stream can therefore be thought of as being derived from one continuous succession of messages with a length distribution whose Laplace transform is again $B^*(s) = u/(u+s)$. Again assume that a message is kept in the sampled stream with probability z . Then the Laplace transform of the off-time distribution for the sampled stream is

$$\begin{aligned} A^*(s)_{\text{sampled}} &= \sum_{n=1}^{\infty} z(1-z)^{n-1} (B^*(s))^n \\ &= \frac{zu}{zu+s} \end{aligned}$$

Similarly, the Laplace transform of the on-time distribution for the sampled stream is

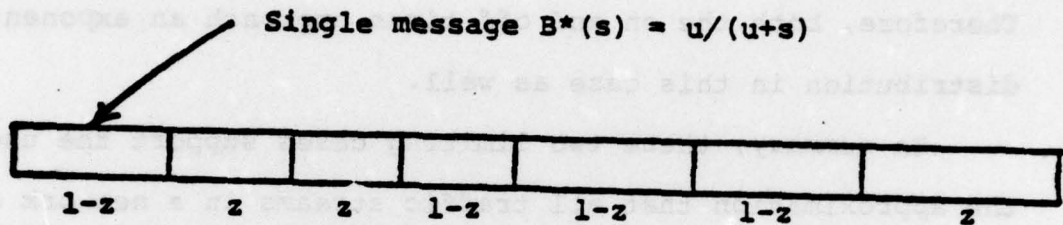

a. Unsampled message stream

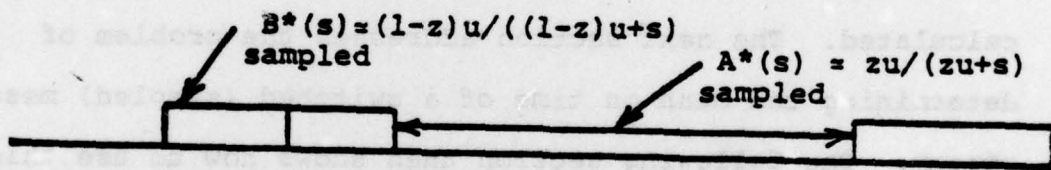

b. Sampled message stream

FIGURE 3.3 - Traffic streams in a network with utilization near one.

$$\begin{aligned}
 B^*(s) &= \sum_{n=1}^{\infty} (1-z)z^{n-1} (B^*(s))^n \\
 &= \frac{(1-z)u}{(1-z)u+s}
 \end{aligned}$$

Therefore, both the on and off times approach an exponential distribution in this case as well.

In summary, these two limiting cases support the use of the approximation that all traffic streams in a network are alternating renewal processes with exponential on and off times when the source traffic streams are of this type. This approximation will be used throughout this chapter. Now that the basic nature of the traffic streams has been specified, the mean on and off times associated with them must be calculated. The next section addresses the problem of determining the mean on time of a switched (sampled) message stream. The following section then shows how to use this result to find all mean traffic parameters in a network of gradual input queues.

3.1.2 Expected on-time for a switched busy period

The one system element not analyzed in the previous chapter is the switch. In order to be able to analyze a general network, one must be able to determine the expected on-time of the busy periods at the output of the switch. The approach taken to this problem is first to calculate the

expected number of messages in a switched busy period. Let N_s denote the number of messages in such a switched busy period. Then the expected time duration of the busy period will be approximated by

$$E\{\text{Time duration of switched busy period}\} = E\{N_s\} \beta_{in} = \frac{E\{N_s\}}{\mu} \quad (\text{Eq.3.3})$$

Where $\beta_{in} = \mu^{-1}$ is the expected length of one message. This relationship is only approximate because the distributions for the number of messages and the message lengths in a busy period are not independent.

First some analysis of an unswitched busy period will be done. Let $E\{N_{us}\}$ be the expected number of messages in an unswitched busy period. Now consider picking one message at random from such a stream of messages. The probability that the message chosen is the last one in a busy period, $\text{Pr}(\text{last message})_{us}$, is given by

$$\begin{aligned} \text{Pr}(\text{Last message})_{us} &= \sum_{n=1}^{\infty} \frac{1}{n} \text{Pr}(\text{length of busy period from which message is chosen} = n) \\ &= \sum_{n=1}^{\infty} \frac{1}{n} \frac{n \text{Pr}(\text{length of busy period} = n)}{E\{N_{us}\}} \\ &= \frac{1}{E\{N_{us}\}} \quad (\text{Eq.3.4}) \end{aligned}$$

The expression for $\text{Pr}(\text{length of busy period from which message is chosen} = n)$ follows from the fact that the message is being chosen by random incidence [DRAKE 67].

Equation 3.4 also applies to a switched message stream, i.e.,

$$\text{Pr}(\text{last message})_s = \frac{1}{E\{N_s\}} \quad (\text{Eq. 3.5})$$

Where $\text{Pr}(\text{last message})_s$ is again the probability that a message chosen by random incidence is the last one in a busy period. The switched stream is of course derived from an unswitched one and therefore

$$\begin{aligned} \text{Pr}(\text{last message})_s &= \text{Pr}(\text{last message})_{us} \\ &+ (1 - \text{Pr}(\text{last message})_{us}) \text{Pr}(\text{message following chosen one is not in switched stream of interest}) \end{aligned}$$

The above states that the last message in a busy period in a switched busy period was either the last message in the unswitched busy period or it became the last message because the message immediately behind it was switched to another stream. Let z be the probability that a message is switched into the stream of interest. Then using Equations 3.4 and 3.5 in the above relation gives

$$\begin{aligned}
 E\{N_s\}^{-1} &= E\{N_{us}\}^{-1} + (1 - E\{N_{us}\}^{-1})(1 - z) \\
 &= z E\{N_{us}\}^{-1} + 1 - z
 \end{aligned}$$

or

$$\mu E\{N_s\}^{-1} = z \mu E\{N_{us}\}^{-1} + \mu(1 - z) \quad (\text{Eq. 3.6})$$

Recalling Equation 3.3, it can be seen that there is a linear relationship between the inverses of the expected time durations of the busy periods at the input and output of a switch. This result will be useful in the next section where the mean traffic parameters in a general network are determined.

3.1.3 Determining the mean traffic parameters in a general network

A general network of queues consists of N nodes (indexed $i=1, 2, \dots, N$). Figure 3.4 gives a detailed view of one of these nodes. As shown, each node has one or more directed output communication channels (indexed $j=1, 2, \dots, j_{\max_i}$). A buffer is associated with each output channel and it is fed by one or more internal node channels (indexed $k=1, 2, \dots, k_{\max_{ij}}$). The internal channels either carry traffic that has been switched from network channels or traffic from source channels outside the network.

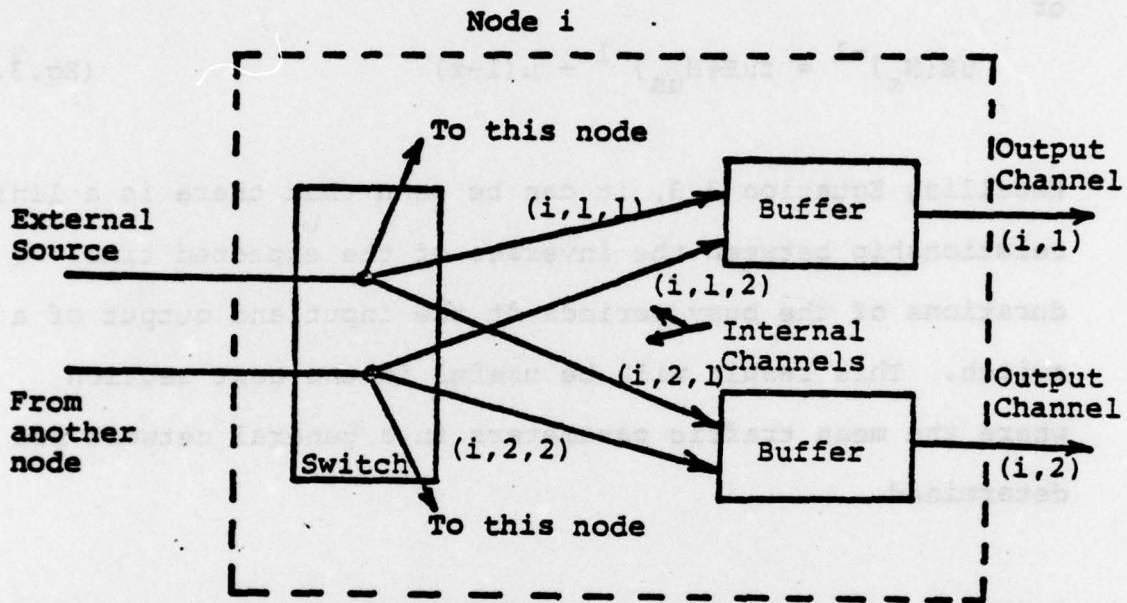

FIGURE 3.4 - Communication channel labeling conventions

It is possible to uniquely identify each communication channel in the network by using the labeling convention given above. Output channels are identified by a number pair (i,j) while internal channels are identified by three numbers (i,j,k) . The mean on and off times on each of these types of channels will be denoted by $\beta_{i,j}$, $\beta_{i,j,k}$, $\lambda_{i,j}^{-1}$ and $\lambda_{i,j,k}^{-1}$ respectively. Similarly, the utilizations of internal and output channels will be $u_{i,j,k}$ and $u_{i,j}$ respectively. These utilizations are defined as follows.

$$u_{i,j,k} = \frac{\beta_{i,j,k}}{\beta_{i,j,k} + \lambda_{i,j,k}^{-1}} \quad (\text{Eq.3.7})$$

$$u_{i,j} = \sum_{k=1}^{k_{\max,i,j}} u_{i,j,k} \quad u_{i,j} \leq 1 \quad (\text{Eq.3.8})$$

Here, as elsewhere, it is implicitly assumed that the capacities of an internal and an output channel are the same. Equation 3.7 states that the utilization of a channel is the fraction of time that it is on. Equation 3.8 states that the utilization of an output channel equals the sum of the utilizations of the associated internal channels.

The problem now is to solve for the mean parameters β and λ everywhere in the network. This can be done by first solving for the utilizations u and then for the mean on times β . The mean off times can then be found using equations like Equation 3.7.

Equation 3.10 may or may not have a solution. Even if there is a solution, the resulting utilizations may be larger than one. These two points are illustrated in Figure 3.5. Figure 3.5a shows a network for which Equation 3.10 has no solution. The problem is that an infinite amount of traffic accumulates inside the network. The utilization equation for the network in Figure 3.5b has a solution, but the utilization u_2 is larger than one. In this case Equation 3.8 is being used in a region where $u_{i,j} > 1$. Equation 3.8 is not valid in this region and furthermore utilizations greater than one are physically not possible. By physical reasoning, one can see that in this case there would also be an infinite accumulation of traffic inside the network. In this study only networks which have a steady state distribution of buffer contents are of interest and this occurs only if Equation 3.10 has a solution with all utilizations < 1 .

The remaining problem now is to solve for the mean on times β everywhere in the network. This is simplified by solving for the reciprocals $\hat{\beta} = \beta^{-1}$ because the $\hat{\beta}$'s obey a set of linear equations. As with the utilizations, there is one type of equation that relates $\hat{\beta}$'s on the two sides of a switch and one that relates the $\hat{\beta}$'s on the two sides of a buffer.

The relationship between the $\hat{\beta}$'s on both sides of a switch follows directly from Section 3.1.2. Recall that

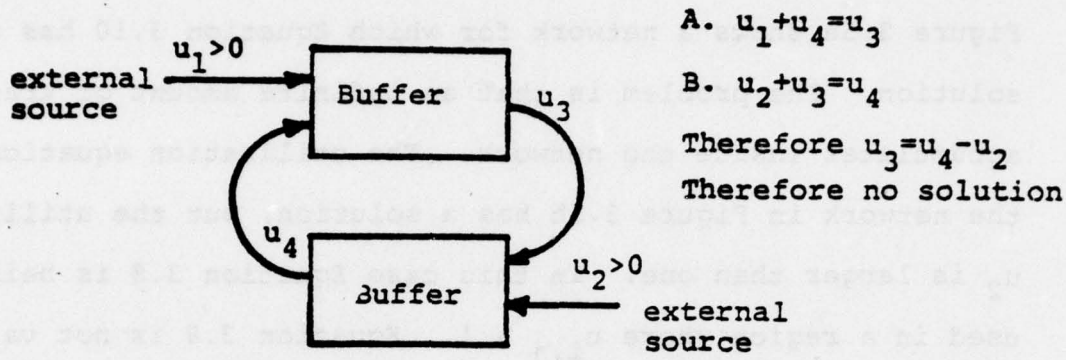

a. A case in which Eq. 3.10 has no solution.

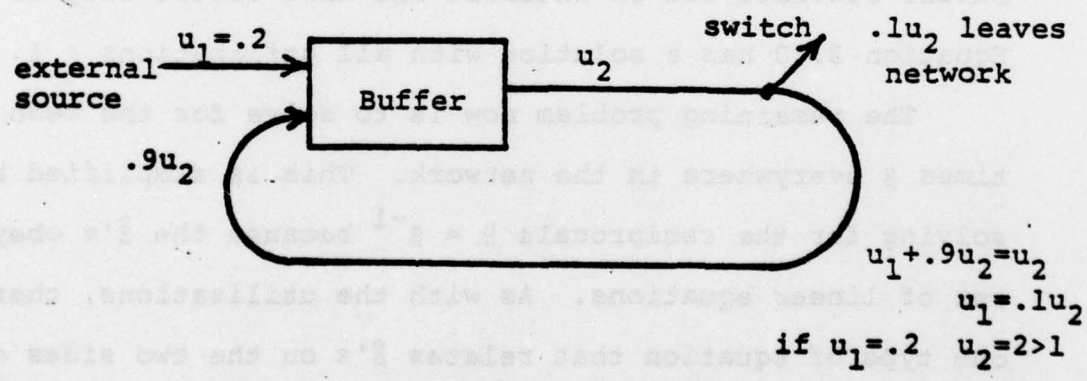

b. A case in which the utilization Eq. 3.10 has a solution, but not all utilizations are ≤ 1 .

FIGURE 3.5 - Networks for which Eq. 3.10 does not give physically meaningful results.

$$\beta_{us} = \mu^{-1} E\{N_{us}\} \quad (\text{Eq. 3.11})$$

and

$$\beta_s = \mu^{-1} E\{N_s\} \quad (\text{Eq. 3.12})$$

where μ^{-1} is the expected length of one message and $E\{N\}$ is the expected number of messages in a busy period. The subscripts us and s refer to unswitched (input to the switch) and switched (output from the switch) streams respectively. Taking the inverses of Equations 3.11 and 3.12, one can substitute directly into Equation 3.6 and obtain the result that

$$\hat{\beta}_s = z \hat{\beta}_{us} + \mu(1-z)$$

Using the indexing convention for communication channels, this becomes

$$\hat{\beta}_{i,j,k} = \hat{\beta}_{m,i} z_{m,i,j,k} + \mu(1-z_{m,i,j,k}) \quad (\text{Eq. 3.13})$$

Now the linear relationship for the β 's on both sides of a buffer will be found. First recall the relationship for output channel utilization

$$u_{i,j} = \frac{\beta_{i,j}}{\beta_{i,j} + \lambda_{i,j}^{-1}}$$

This can be rearranged to give

$$\beta_{ij} = \frac{1}{\lambda_{i,j}} \left(\frac{u_{ij}}{1 - u_{ij}} \right)$$

or

$$\hat{\beta}_{ij} = \lambda_{i,j} \left(\frac{1 - u_{ij}}{u_{ij}} \right) \quad (\text{Eq. 3.14})$$

A similar relationship exists for the input channels of the buffer.

$$\hat{\beta}_{i,j,k} = \lambda_{i,j,k} \left(\frac{1 - u_{i,j,k}}{u_{i,j,k}} \right) \quad (\text{Eq. 3.15})$$

Equations 3.14 and 3.15 can be tied together by recognizing that for a gradual input queue

$$\lambda_{i,j} = \sum_{k=1}^{k_{\max}} \lambda_{i,j,k} \quad (\text{Eq. 3.16})$$

Equation 3.16 states that the rate at which off periods on the output channel end, $\lambda_{i,j}$, is equal to the sum of the rates at which off periods end on the input channels. This is true since the off periods on the input channels are assumed to be exponentially distributed. Combining Equations 3.14, 3.15 and 3.16, one obtains the linear relationship

$$\hat{\beta}_{i,j} = \left(\frac{1-u_{i,j}}{u_{i,j}} \right) \sum_{k=1}^{k_{\max_{i,j}}} \hat{\beta}_{i,j,k} \left(\frac{u_{i,j,k}}{1-u_{i,j,k}} \right) \quad (\text{Eq.3.17})$$

Since the utilizations $u_{i,j}$ and $u_{i,j,k}$ have previously been determined, the β 's can now be obtained.

Equations 3.13 and 3.17 can also be written as one matrix equation as follows.

$$\begin{bmatrix} 0 & | & \bar{Z} \\ \hline \bar{U}_c & | & 0 \end{bmatrix} \begin{bmatrix} \bar{\beta}_{\text{int}} \\ \hline \bar{\beta}_{\text{out}} \end{bmatrix} + \mu \begin{bmatrix} 1-z_{m,i,j,k} \\ \vdots \\ 1-z_{m,i,j,k} \\ \hline 0 \end{bmatrix} = \begin{bmatrix} \bar{\beta}_{\text{int}} \\ \hline \bar{\beta}_{\text{out}} \end{bmatrix}$$

(Eq.3.18)

The matrix \bar{U}_c is the matrix of coefficients implied by Equation 3.17. The matrix \bar{Z} is again the routing matrix while $\bar{\beta}_{\text{int}}$ and $\bar{\beta}_{\text{out}}$ are vectors of reciprocal expected on times for internal and output channels respectively.

The remaining question is how to solve this set of equations. The author has found that Picard iteration is a particularly convenient way. This follows from the fact that Equation 3.18 is of the form

$$Q(\hat{\beta}) = \hat{\beta} \quad (\text{Eq.3.19})$$

If certain requirements are met, this can be solved by an iteration scheme (Picard iteration) of the form

$$Q(\hat{\beta}_n) = \hat{\beta}_{n+1} \quad n = 1, 2, \dots$$

From the contraction mapping theorem [DESOER 75] it is known that this iteration scheme will converge to the unique solution of Equation 3.19 if

$$\|Q(\hat{\beta}_1) - Q(\hat{\beta}_2)\| < c \|\hat{\beta}_1 - \hat{\beta}_2\|$$

where $c < 1$ and $\hat{\beta}_1$ and $\hat{\beta}_2$ are any two points.

Examining Equation 3.18 it can be seen that this will be true if the largest eigenvalue of the matrix $\begin{matrix} 0 & \bar{Z} \\ \bar{U}_c & 0 \end{matrix}$ is < 1 .

This matrix contains only positive elements. Therefore if the sum of the elements in each row is < 1 , the largest eigenvalue will also be < 1 .[†] This will be the case if there is switching and combining in buffers at each node of the network. If there is switching, each row of the matrix \bar{Z} will have a sum < 1 . If there is combining in each buffer, then there will be at least two nonzero $\mu_{i,j,k}$ for each buffer. Therefore the row sums of \bar{U}_c will be

[†] See the Appendix on positive matrices in Karlin and Taylor [KARL 75].

$$\left(\frac{1-u_{i,j}}{u_{i,j}}\right) \sum_{k=1}^{k_{\max}} u_{i,j,k} < \frac{1-u_{i,j}}{\min_k (1-u_{i,j,k})} < 1$$

Note that if there is a switch for which $z=1$ or a buffer in which no combining is occurring, the input and output streams for that network element will be the same. Therefore variables can be eliminated so that the largest eigenvalue of the matrix in Equation 3.18 will be < 1 . Picard iteration can therefore always be used to find the unique solution. In practice, the Picard iteration works well using an initial guess of all $\hat{\beta}$'s = $\beta_{in} = 1$.

3.1.4 Simulation verification

This section presents simulation results that support the use of the approximation that all traffic streams in a general network of gradual input queues are alternating renewal processes with exponentially distributed on and off times. Section 3.1.1 showed that this approximation becomes exact when all channel utilizations are near zero or one. The purpose of the simulation is to show that the approximation is also reasonable for other utilizations.

The simulation was done for a queueing system as shown in Figure 3.6. The system consists of a gradual input queue followed by a routing switch. The inputs to the system are alternating renewal processes with exponentially distributed on and off times. The simulation then obtained the

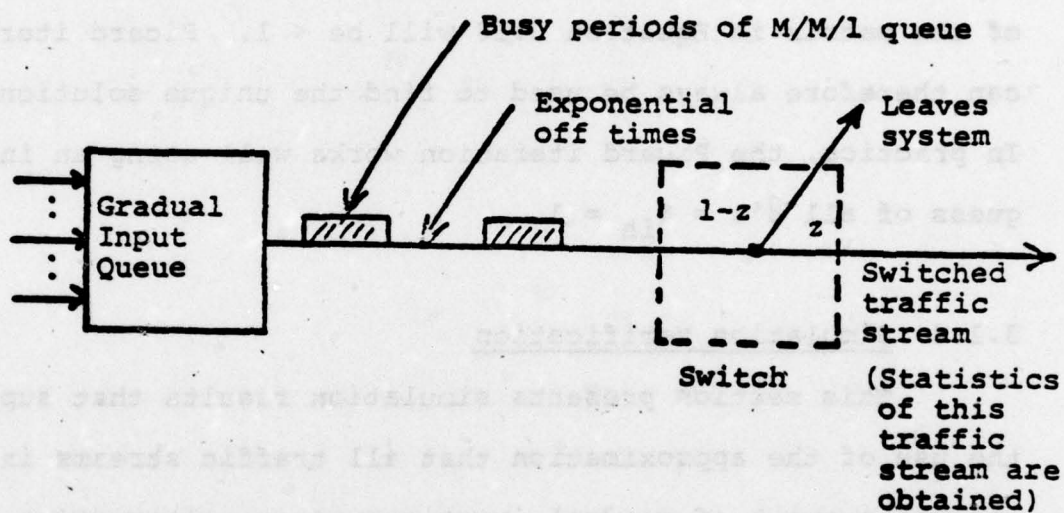
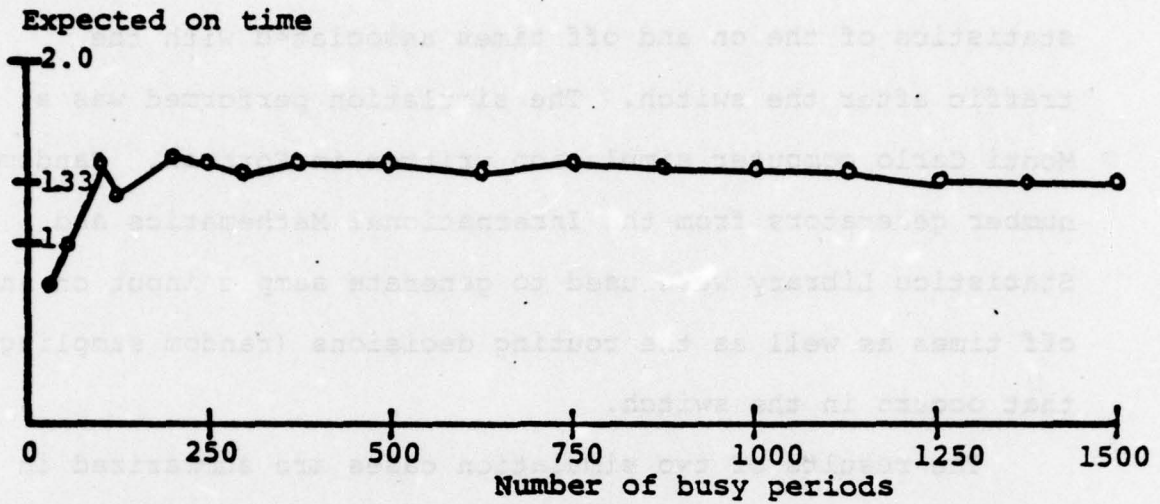

FIGURE 3.6 - Gradual input queueing system studied by simulation.

statistics of the on and off times associated with the traffic after the switch. The simulation performed was a Monte Carlo computer simulation written in Fortran. Random number generators from the International Mathematics and Statistics Library were used to generate sample input on and off times as well as the routing decisions (random sampling) that occurs in the switch.

The results of two simulation cases are summarized in Figures 3.7 to 3.10. In both cases the mean message length β_{in} is one and the fraction of traffic kept in the stream of interest, z , is 0.5. In Case 1 the utilization of the output channel of the gradual input queue is 0.5 while in Case 2 it is 0.8. The results in Figures 3.7 and 3.9 show that the approximations used in this chapter are good for calculating the mean on and off times for the switched traffic stream. Figures 3.8 and 3.10 give histograms of the sample lengths of the switched on and off times. Also shown are the theoretical histograms for the exponential distributions assumed in the approximations. These results indicate that the exponential distribution assumptions are indeed reasonable for calculating traffic stream parameters in a general network. If the requirement that buffer input traffic streams are independent is also reasonably met, then, using these traffic parameters with the gradual input queue will give good results.



a. Expected on time for a switched busy period.
Value calculated using approximations=1.33.

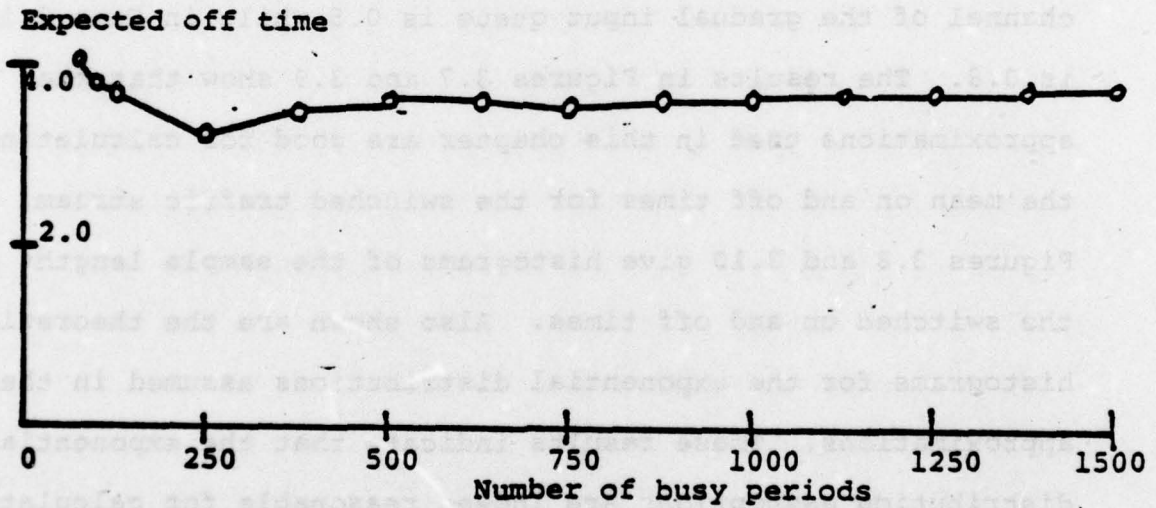

b. Expected off time for a switched traffic stream.
Value calculated using approximations=4.0.

FIGURE 3.7 - Simulation results Case 1. See text for details.

Percent of total busy periods

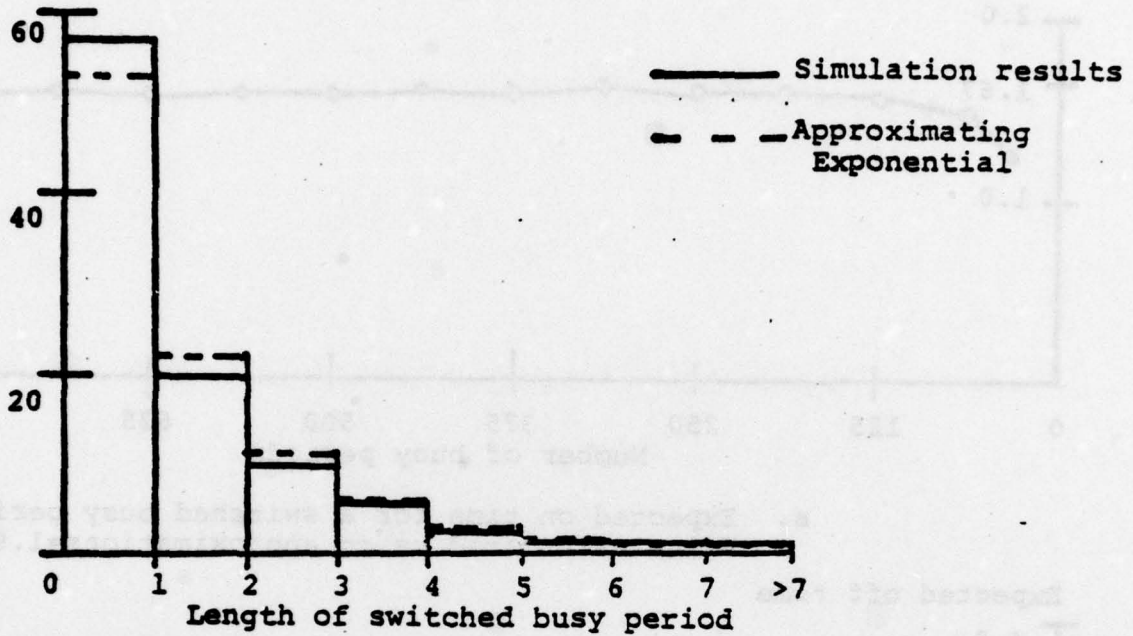

Percent of total off times

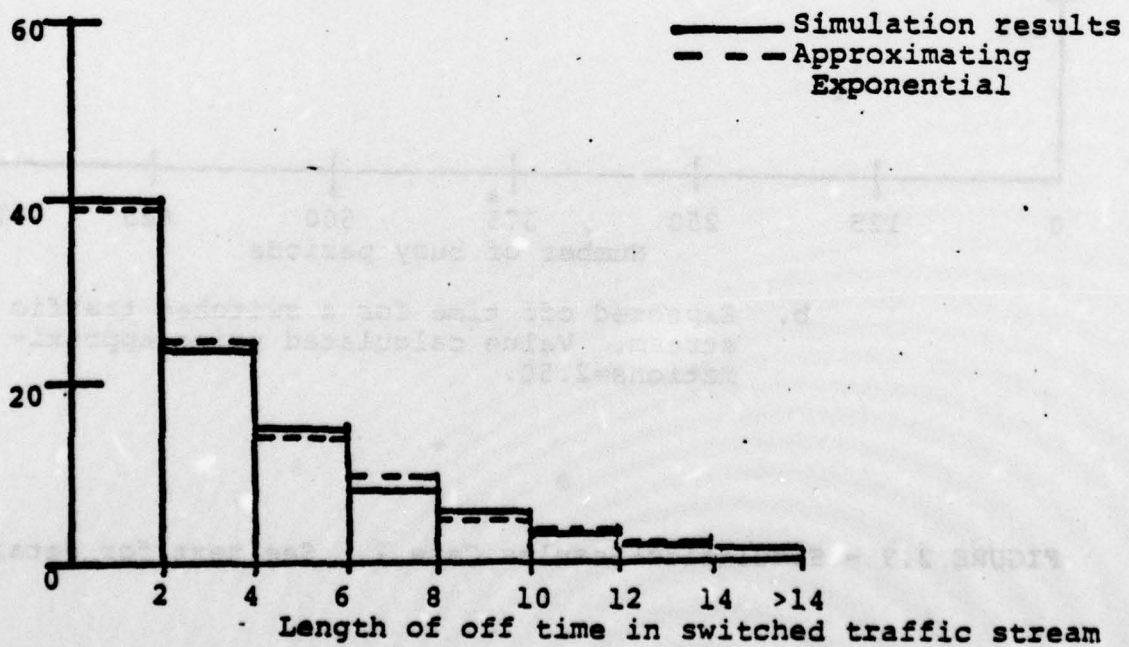
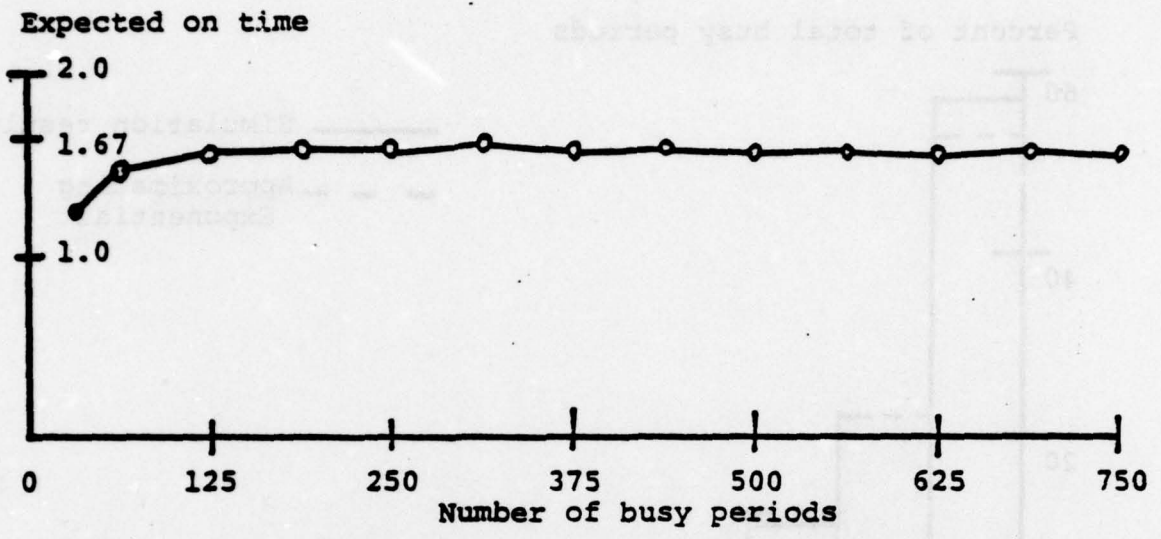
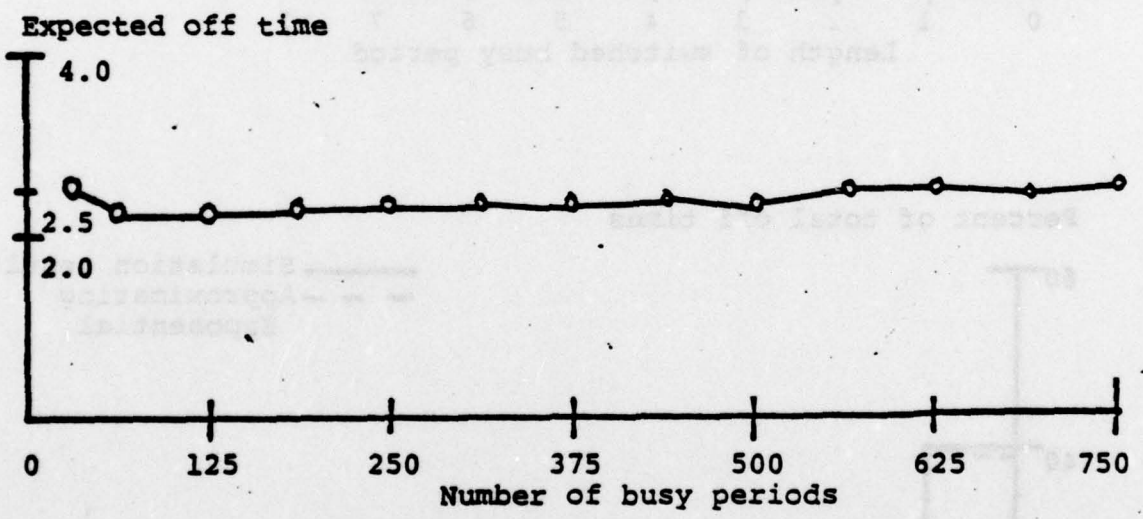

FIGURE 3.8 - Simulation results for Case 1. See text for details



a. Expected on time for a switched busy period. Value calculated using approximations=1.67.



b. Expected off time for a switched traffic stream. Value calculated using approximations=2.50.

FIGURE 3.9 - Simulation Results Case 2. See text for details.

Percent of total busy periods

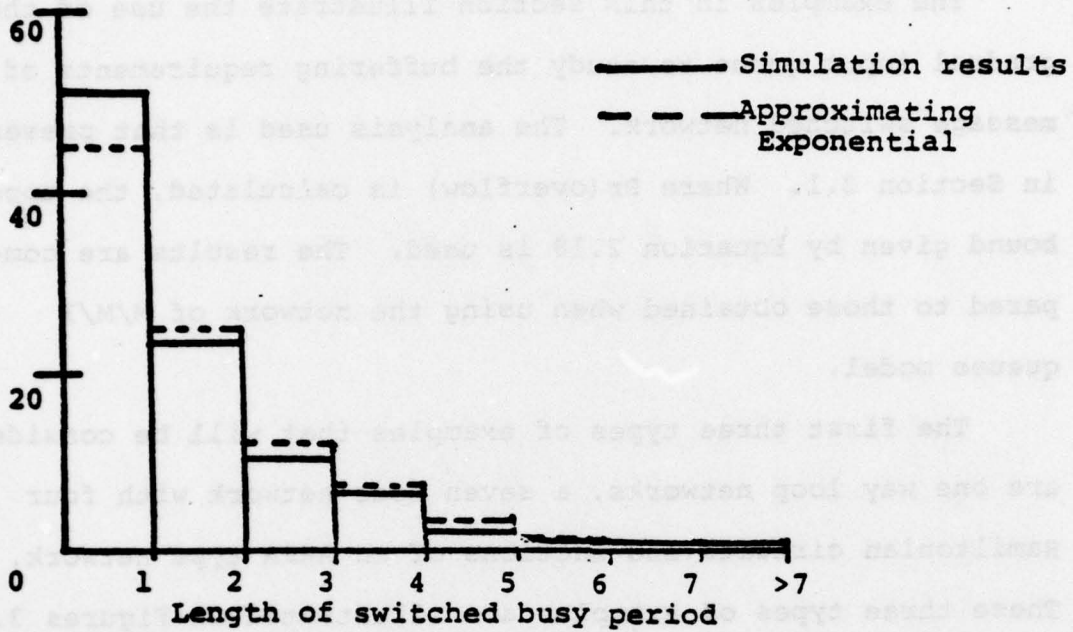

Percent of total off times

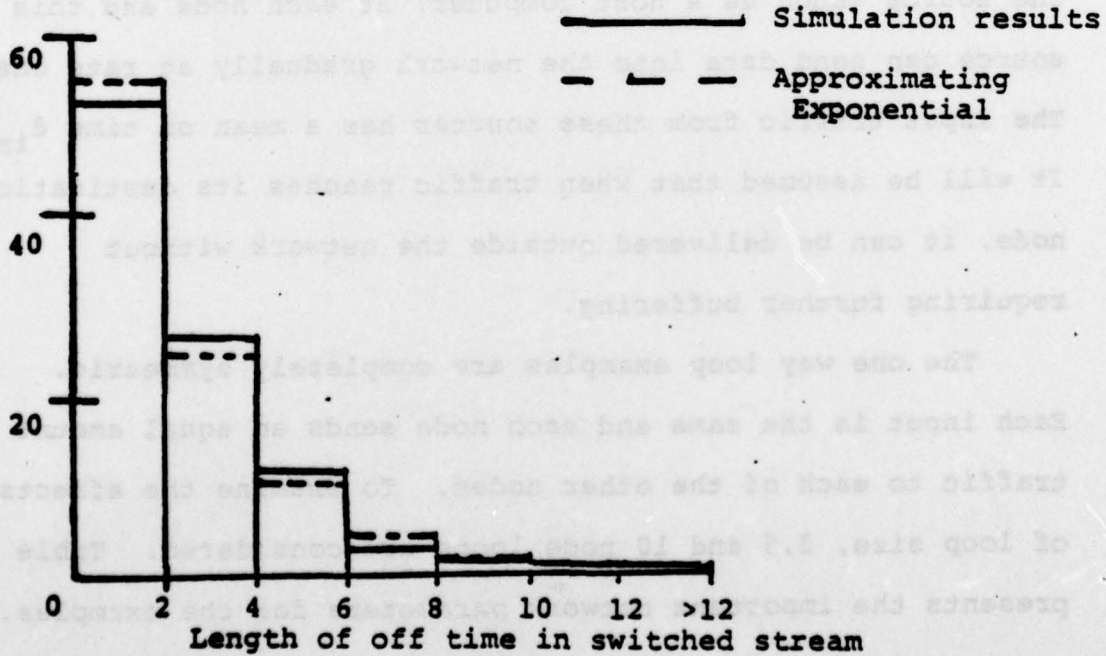

FIGURE 3.10 - Simulation results for Case 2. See text for details

3.2 Examples of General Networks

The examples in this section illustrate the use of the gradual input queue to study the buffering requirements of a message switched network. The analysis used is that presented in Section 3.1. Where $Pr(\text{overflow})$ is calculated, the upper bound given by Equation 2.18 is used. The results are compared to those obtained when using the network of M/M/1 queues model.

The first three types of examples that will be considered are one way loop networks, a seven node network with four Hamiltonian circuits and sections of an ARPA type network. These three types of examples are illustrated in Figures 3.11 to 3.13. For each of these networks it will be assumed that all communication channels have a capacity of one. There is one source (such as a host computer) at each node and this source can send data into the network gradually at rate one. The input traffic from these sources has a mean on time $\beta_{in}=1$. It will be assumed that when traffic reaches its destination node, it can be delivered outside the network without requiring further buffering.

The one way loop examples are completely symmetric. Each input is the same and each node sends an equal amount of traffic to each of the other nodes. To examine the effects of loop size, 3,5 and 10 node loops are considered. Table 3.2 presents the important network parameters for the examples.

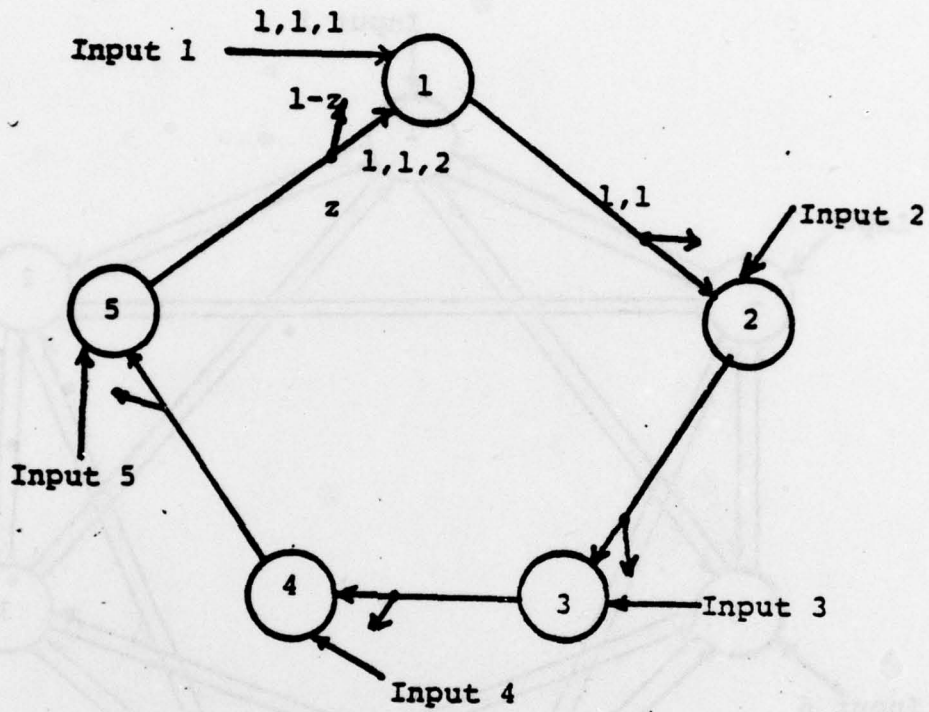

FIGURE 3.11 - A five node one-way loop network

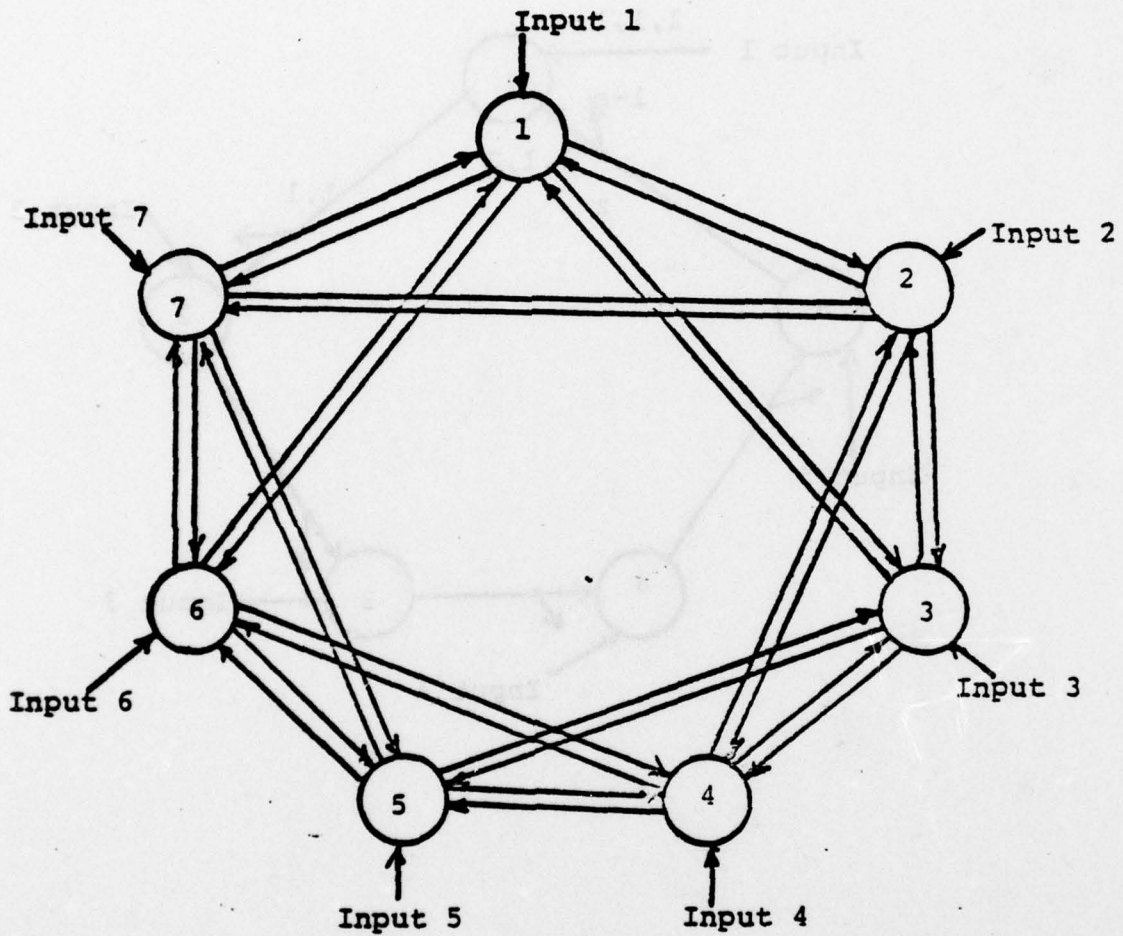

FIGURE 3.12 - A seven node network with four Hamiltonian circuits

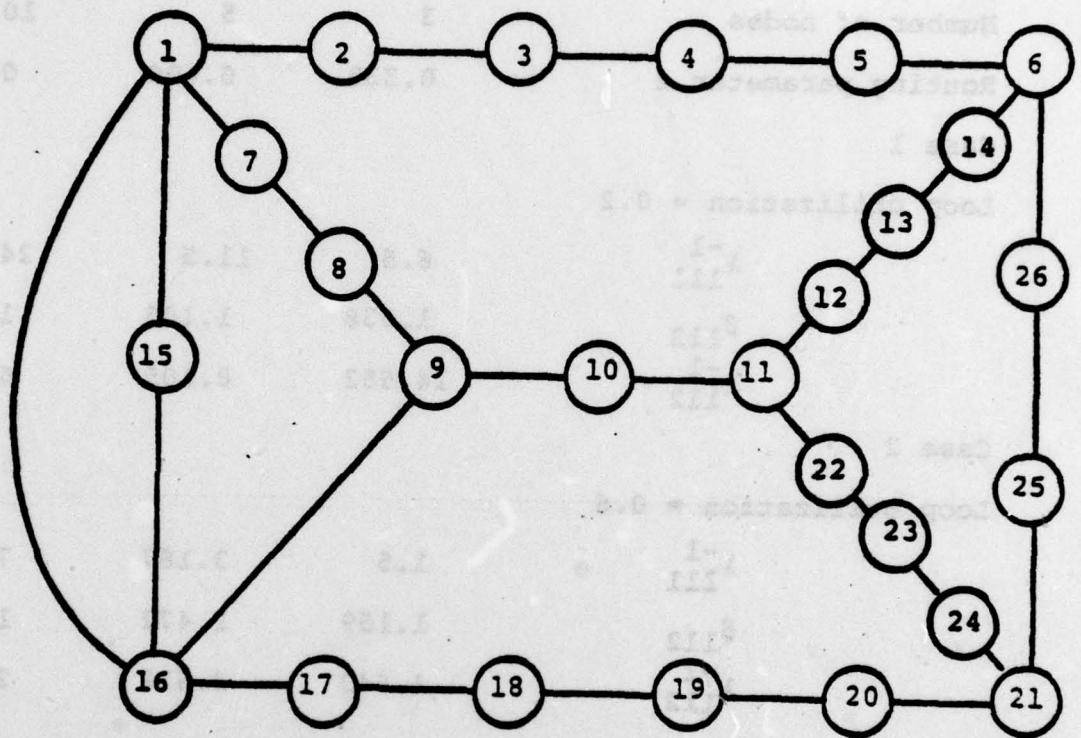

FIGURE 3.13 - A 26 node ARPA type network. Each arc represents two directed communication channels.

Table 3.2

Parameters for the Loop Network Examples

For all cases $\beta_{111} = \beta_{in} = 1$

Number of nodes	3	5	10
Routing parameter z	0.333	0.600	0.800
Case 1			
Loop utilization = 0.2			
λ_{111}^{-1}	6.5	11.5	24.0
β_{112}	1.038	1.105	1.171
λ_{112}^{-1}	14.552	8.105	6.150
Case 2			
Loop utilization = 0.6			
λ_{111}^{-1}	1.5	3.167	7.333
β_{112}	1.159	1.472	1.862
λ_{112}^{-1}	4.643	2.618	2.017
Case 3			
Loop utilization = 0.9			
λ_{111}^{-1}	0.667	1.778	4.556
β_{112}	1.361	2.107	3.514
λ_{112}^{-1}	3.184	1.795	1.369

The cases presented give network operation at three different utilizations, 0.2, 0.6 and 0.9. A graph of the Pr(overflow) vs. buffer size for the utilization = 0.6 case is given in Figure 3.14.

Two effects occur in these loops. First, as loop size increases, the length of busy periods inside the loop, β_{112} , increase. This tends to increase queueing. Second, as loop size increases, a larger fraction of the traffic into each node arrives over one channel (the internal loop channel). This tends to decrease queueing. Figure 3.14 shows that the first effect dominates in going from a 3 to 5 node loop while the second effect dominates in going from a 5 to 10 node loop.

Note that these effects cannot be observed using the M/M/1 model. The M/M/1 model always indicates the same amount of queueing for a given utilization, no matter what the size of the loop. The M/M/1 curve in Figure 3.14 therefore applies to any size loop operating at a utilization of 0.6.

As a second example, the seven node network in Figure 3.12 will be used to show the dramatic effects of having gradual inputs for the sources. The traffic in this network will also be assumed to be symmetrical. The routing for the traffic is illustrated in Figure 3.15. Note that each channel in the perimeter Hamiltonian circuits carries traffic from only one source. Since that source provides a gradual input

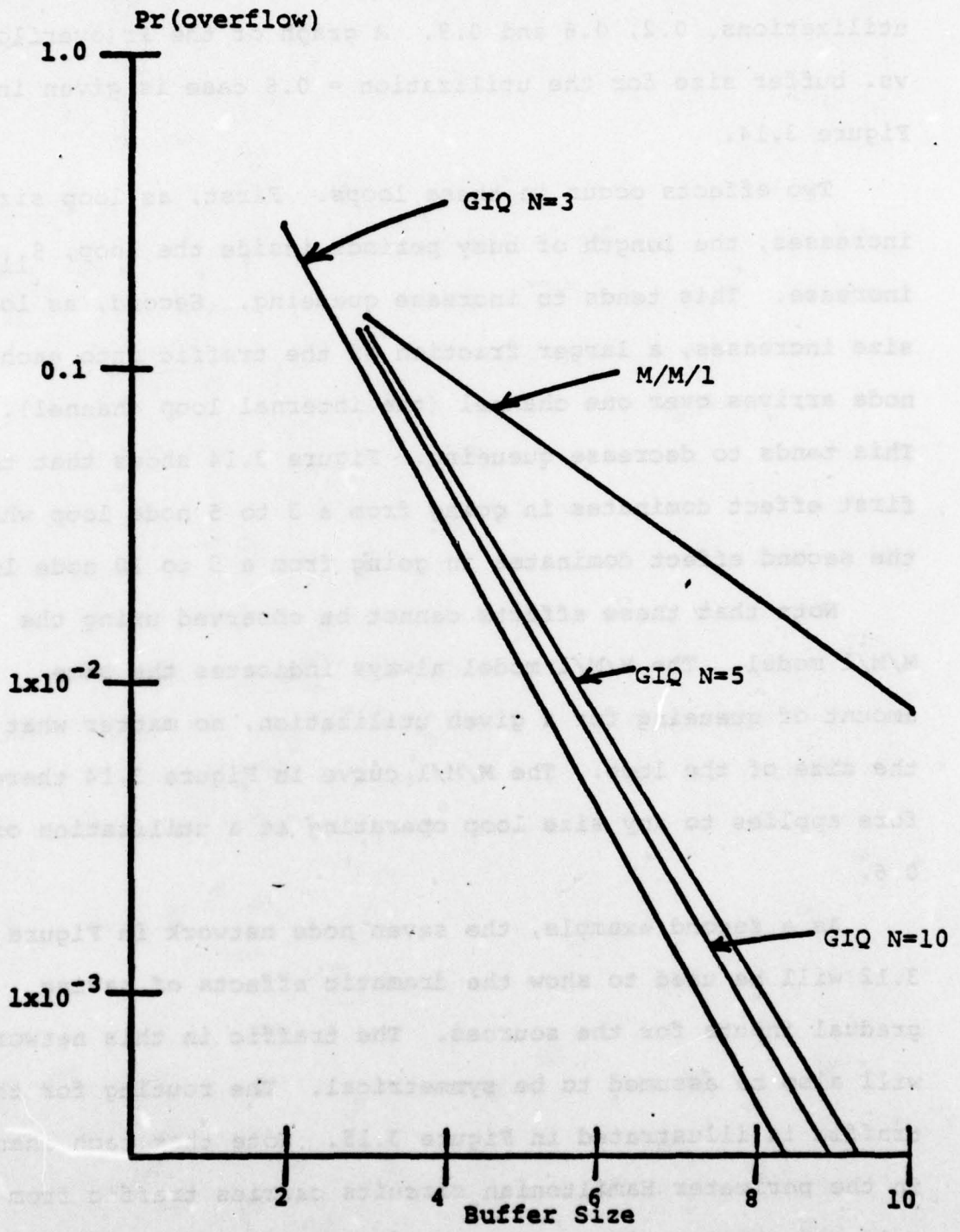

FIGURE 3.14 - $Pr(\text{overflow})$ for loop networks. Case 2 in Table 3.2.

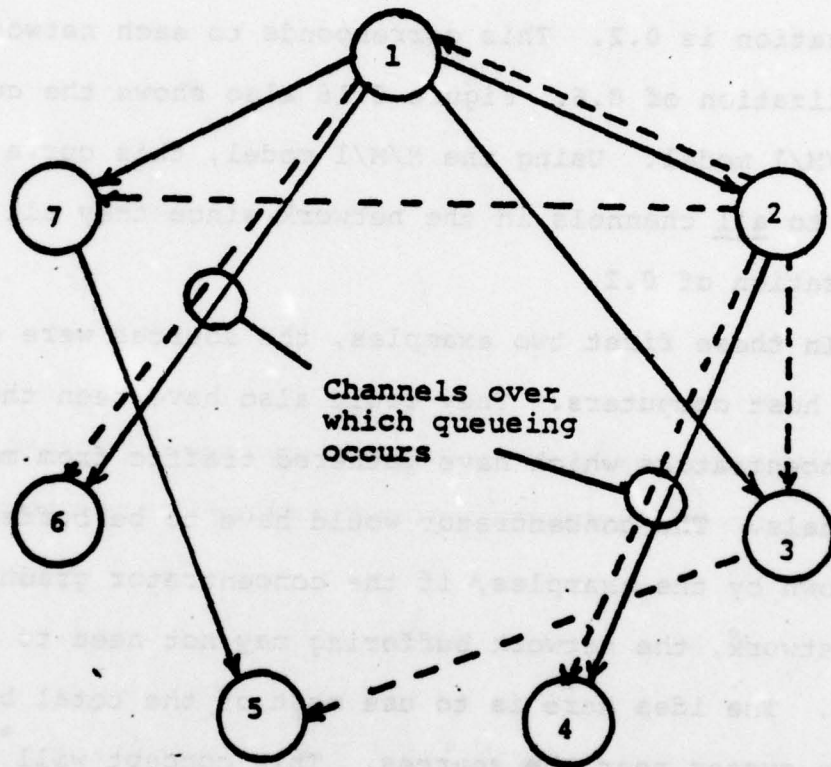

FIGURE 3.15 - Routing in the seven node network

as the communication channel capacity, there is no queueing on these channels! The only channels which have queueing are the internal Hamiltonian circuits. Each of these are gradual input queues with two inputs. Figure 3.16 shows the $Pr(\text{overflow})$ vs. buffer size for these channels if their utilization is 0.2. This corresponds to each network having a utilization of 0.6. Figure 3.16 also shows the curve for the M/M/1 model. Using the M/M/1 model, this curve would apply to all channels in the network since they all have a utilization of 0.2.

In these first two examples, the sources were considered to be host computers. They could also have been the outputs of concentrators which have gathered traffic from many terminals. The concentrator would have to be buffered, but as shown by the examples, if the concentrator gradually feeds the network, the network buffering may not need to be too large. The idea here is to use most of the total buffering in the system near the sources. This concept will be explored further in Chapter 4.

A question to be asked now is whether or not the use of the gradual input model gives widely different results than the M/M/1 model for networks that have actually been implemented. Figure 3.13 shows the a 26 node version of the ARPA network. A major topological feature of the network is that it contains long chains of nodes. It is in these chains that the gradual input model differs most from the M/M/1 model.

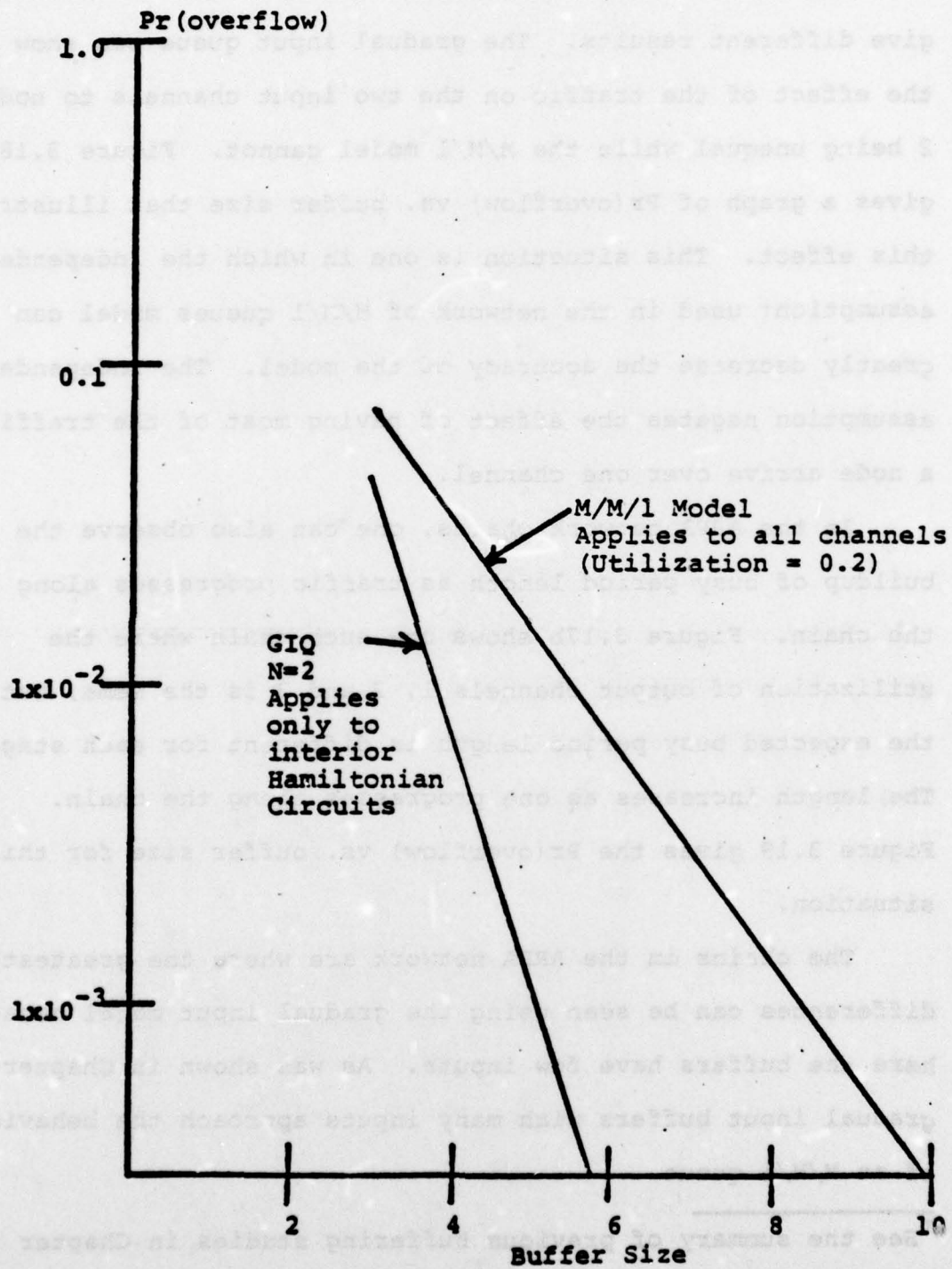

FIGURE 3.16 - Pr(overflow) for the seven node network.

Figure 3.17 shows a situation in which the two models give different results. The gradual input queue can show the effect of the traffic on the two input channels to node 2 being unequal while the M/M/1 model cannot. Figure 3.18 gives a graph of $\text{Pr}(\text{overflow})$ vs. buffer size that illustrates this effect. This situation is one in which the independence assumption[†] used in the network of M/M/1 queues model can greatly decrease the accuracy of the model. The independence assumption negates the effect of having most of the traffic at a node arrive over one channel.

In the ARPA network chains, one can also observe the buildup of busy period length as traffic progresses along the chain. Figure 3.17b shows one such chain where the utilization of output channels 1, 2 and 3 is the same, but the expected busy period length is different for each stage. The length increases as one progresses along the chain. Figure 3.19 gives the $\text{Pr}(\text{overflow})$ vs. buffer size for this situation.

The chains in the ARPA network are where the greatest differences can be seen using the gradual input model because here the buffers have few inputs. As was shown in Chapter 2, gradual input buffers with many inputs approach the behavior of an M/M/1 queue.

[†]See the summary of previous buffering studies in Chapter 1.

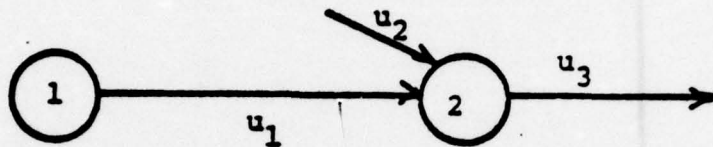

a. A two node chain used to study the effects of $u_1 \neq u_2$.

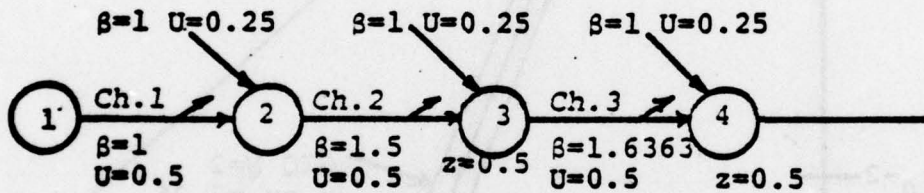

b. A long chain showing the buildup of busy period length.

FIGURE 3.17 - Queueing in chains of gradual input queues.

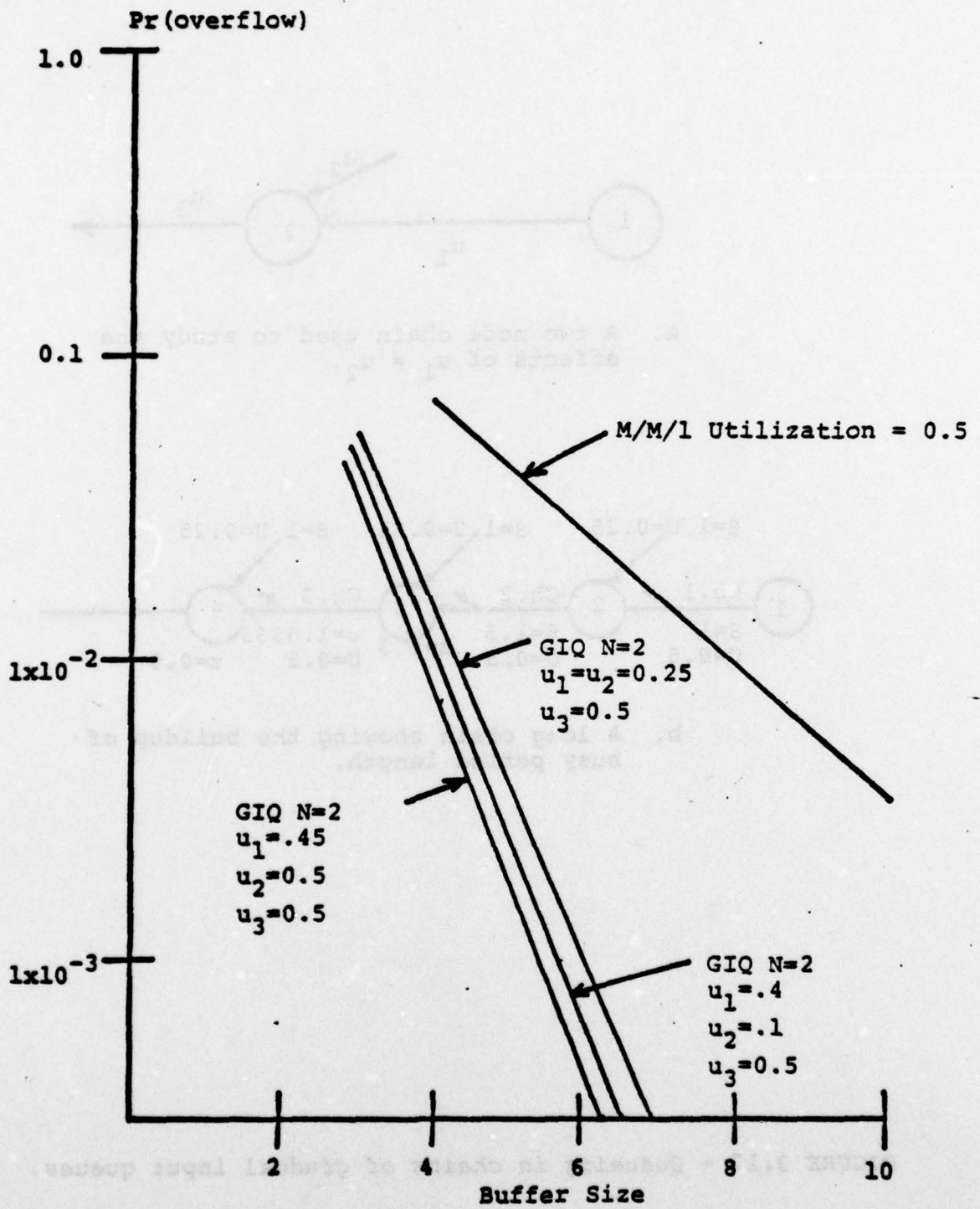

FIGURE 3.18 - $Pr(\text{overflow})$ for Figure 3.17a.

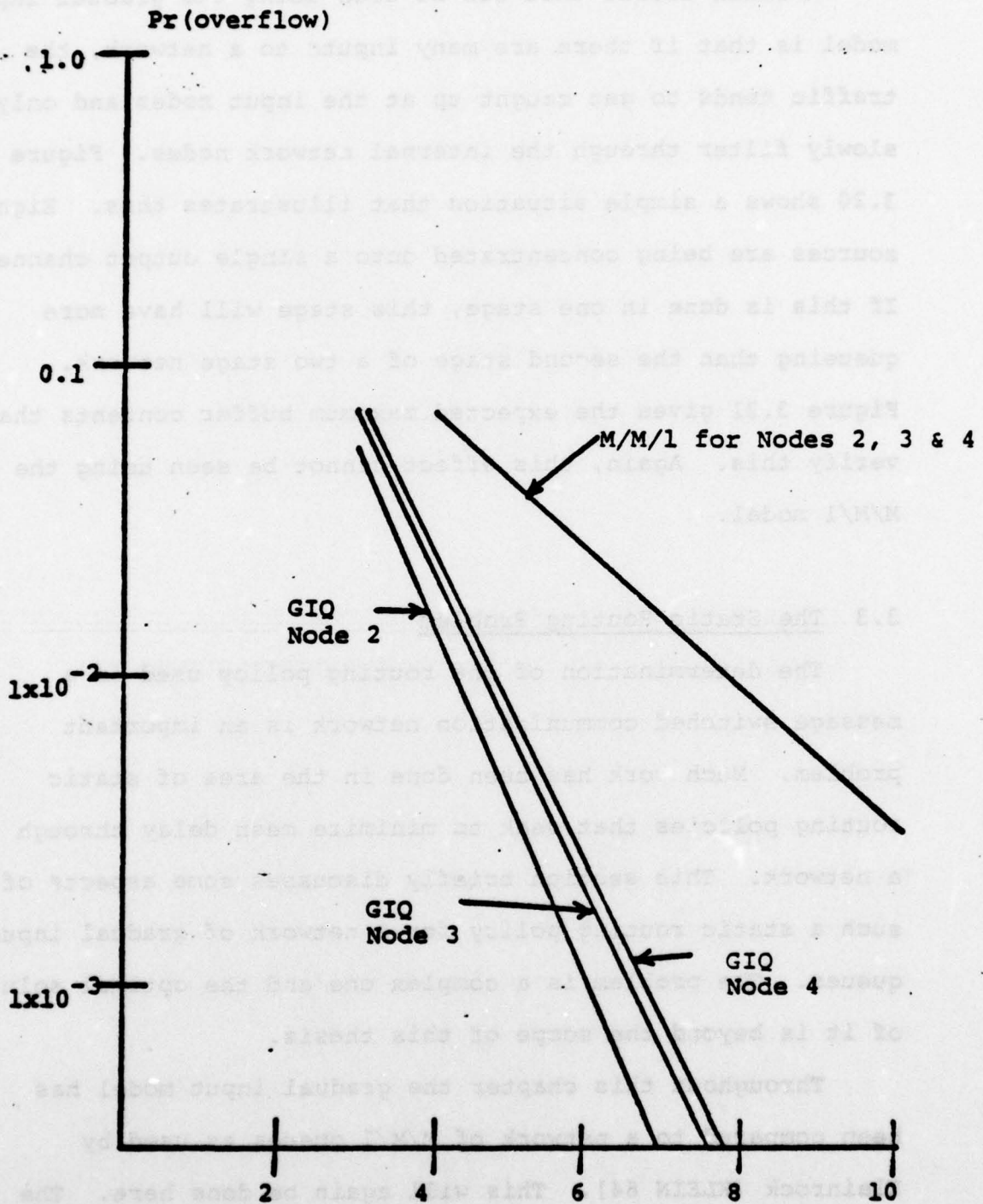

FIGURE 3.19 - $Pr(\text{overflow})$ for chain in Figure 3.17b.

A final effect that can be seen using the gradual input model is that if there are many inputs to a network, the traffic tends to get caught up at the input nodes and only slowly filter through the internal network nodes. Figure 3.20 shows a simple situation that illustrates this. Eight sources are being concentrated onto a single output channel. If this is done in one stage, this stage will have more queueing than the second stage of a two stage network. Figure 3.21 gives the expected maximum buffer contents that verify this. Again, this effect cannot be seen using the M/M/1 model.

3.3 The Static Routing Problem

The determination of the routing policy used in a message switched communication network is an important problem. Much work has been done in the area of static routing policies that seek to minimize mean delay through a network. This section briefly discusses some aspects of such a static routing policy for a network of gradual input queues. The problem is a complex one and the optimal solution of it is beyond the scope of this thesis.

Throughout this chapter the gradual input model has been compared to a network of M/M/1 queues as used by Kleinrock [KLEIN 64]. This will again be done here. The optimization problem of static routing (using mean delay/

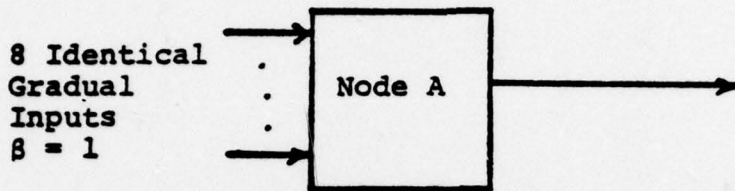

a. One stage concentration

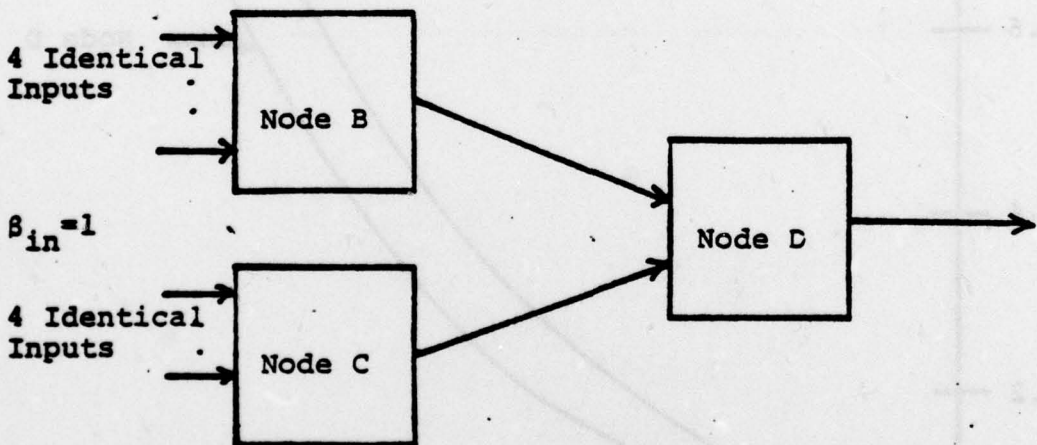

b. Two stage concentration

FIGURE 3.20 - Example showing that traffic is caught up at the input nodes.

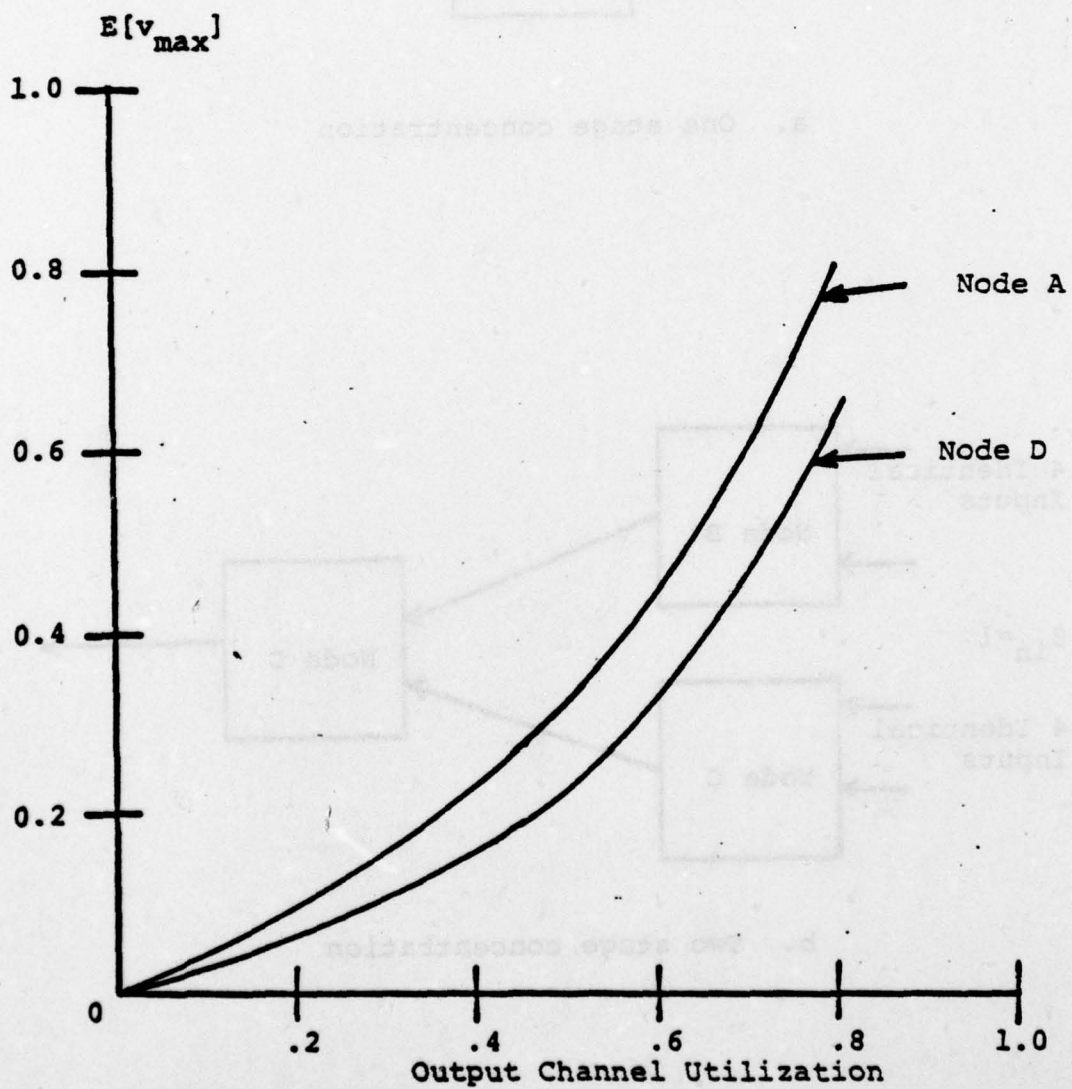

FIGURE 3.21 - Expected maximum buffer content in a busy period for the concentration structures in Figure 3.20

message as the criterion) has been solved by Cantor and Gerla [CANT 74]. They have shown that the problem can be formulated as a multicommodity flow problem. Their problem formulation is:

Given: A network of N nodes and NA directed channels with finite capacities and an $N \times N$ matrix $\bar{R}=[r_{ij}]$ whose entries are the required mean flows between nodes i and j .

Minimize: The mean delay/message through the network.

Constraints: 1. The requirements r_{ij} are met.
2. The flow through each channel is less than or equal to its capacity.

This problem is solved by a mathematical programming algorithm which finds the mean flows through the network that produce minimal delay. The algorithm relies on the fact that the region of feasible flows (flows which satisfy the constraints) is a convex polyhedron and that the objective function is a convex function of the flows. From the optimal mean flows, a routing policy is determined. The mean flow solution does not uniquely specify a routing policy, however all policies giving the same mean flow have the same mean delay in the M/M/1 model. This correspondence between mean flows and mean delay is central in the Cantor and Gerla analysis. This relationship does not hold for networks of gradual input queues as will be shown below.

A minimum mean delay/bit static routing problem for a network of gradual input queues has basically the same statement as that given by Cantor and Gerla. The only difference in the statement is the objective function. Since the exact expression for the mean delay/bit for a gradual input queue has not been determined, either the upper or lower bound developed in Section 2.1.3 must be used. Let $E[d_i]$ be the chosen bound on the expected delay per bit for the i th channel, u_i be the throughput through that channel and u_t be the total throughput for the network. Then the objective function for expected delay/bit would be

$$E[d] = \frac{1}{u_t} \sum_{i=1}^{NA} u_i E[d_i]$$

As an illustration of the routing problem for gradual input queues, consider the simple network shown in Figure 3.22. In this example there are two inputs with traffic for the same destination. Since there are no other inputs in this example, it is easy to see that the minimum delay/bit routing solution is to send all the traffic from one source over channels 1 and 2 and send all of the traffic from the other source over channel 3. This solution produces no waiting lines at any of the channel buffers and therefore has minimum delay. Any other static routing policy would

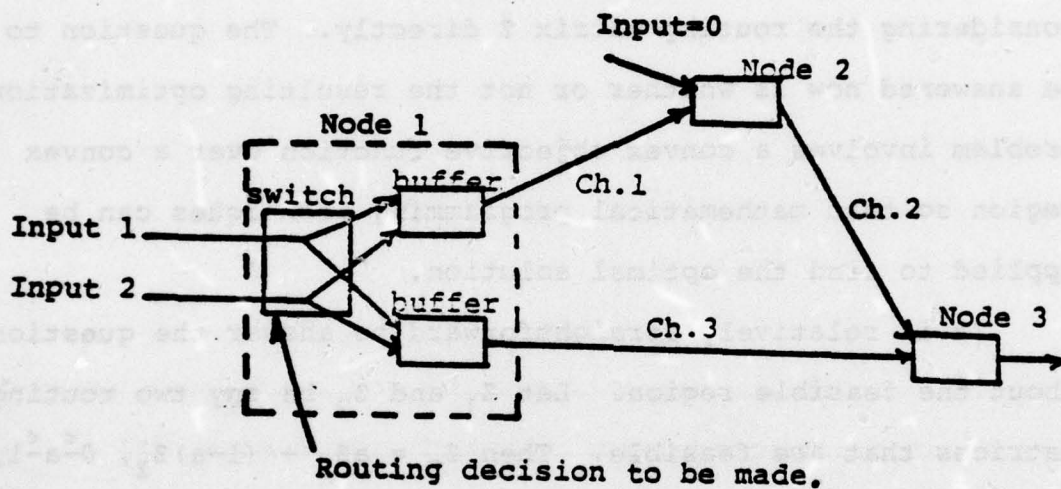

FIGURE 3.22 - A simple example of the static routing problem.

produce a waiting line in the buffers for channels 1 and 3. Some of these other policies would produce the same mean flows as the optimal policy, but would have a different delay.

Because the mean delay/bit is not specified by mean flows alone, the routing optimization must be done by considering the routing matrix Z directly. The question to be answered now is whether or not the resulting optimization problem involves a convex objective function over a convex region so that mathematical programming techniques can be applied to find the optimal solution.

It is relatively straightforward to answer the question about the feasible region. Let Z_1 and Z_2 be any two routing matrices that are feasible. Then $Z_3 = aZ_1 + (1-a)Z_2$, $0 \leq a \leq 1$, is also feasible. This is because Z_3 sends a fraction a of all traffic according to policy Z_1 and a fraction $(1-a)$ according to policy Z_2 . Clearly this meets both the flow requirements between node pairs and the capacity constraint. Therefore, since Z_3 is feasible, the feasible region for the overall problem is convex.

Unfortunately, the objective function $E[d]$ is not convex. The example in Figure 3.22 points this out. Clearly in this case there are two solutions which give no queueing and therefore are optimal. Since the objective function is not convex, applying mathematical programming techniques to the problem does not guarantee that the solution found is globally

optimum. It should be noted, however, that the two solutions in the small example are both globally optimum and in some sense equivalent. If the objective function is such that there are no locally optimum points that are not globally optimum, finding one of them using mathematical programming would be very useful.

It should also be noted that if dynamic routing were used in this example, then the objective function would be convex. This follows from the fact that any convex combination of the above two mean flow solutions could be used while achieving no queueing at node 1. Dynamic strategies can theoretically give superior performance in many network situations, but their analysis is difficult and is beyond the scope of this thesis. Dynamic routing strategies remain an area for future research.

CHAPTER IV - FLOW CONTROL IN TREE CONCENTRATION STRUCTURES

The analysis of message switched communication networks presented thus far has not considered the use of flow control rules. The purpose of this chapter is to study flow control in tree concentration structures. The flow control studied is used to prevent buffer overflow in the interior of the tree structure, i.e. any overflows will be at the nodes to which sources are directly connected.

The flow control rules that can be used in a system depend to a certain extent on the buffers available in the system. Therefore the problem of buffer allocation is considered in the first section of this chapter. It is shown that, in certain cases, placing all buffers at source nodes in the tree allows the system to operate with the smallest probability of buffer overflow. The flow control policy that minimizes the probability of buffer overflow for these cases is then discussed. The section ends with the presentation of an example which shows that it is not always optimal to place all buffers at the source nodes.

The second section of this chapter deals with the approximate analysis of a concentration tree in which flow control is being used. It is shown that the tree can be analyzed one stage at a time, the coupling of the dynamics

between stages being approximately represented. The approximations made are supported by a theorem for first passage times in Markov Chains and by simulation.

4.1 Determining the Optimum Buffer Allocation in a Tree Concentration Structure

4.1.1 The optimality of buffering only at source nodes

The problem of determining the buffer allocation in a tree concentration structure using flow control that minimizes the probability of buffer overflow is best studied by considering specific examples. As a first example, the two level tree shown in Figure 4.1 will be studied. The tree structure considered here is symmetric so that the stage 1 nodes are both assumed to have a buffer size x and stage 2 is assumed to have a buffer size y . The output channel of stage 2 has capacity $C_0 = 1$ and the channels between the two stages are assumed to have capacities less than or equal to C_0 . This restriction on the channel capacities between the stages is important in determining the optimal buffer allocation in the tree structure.

The tree structure in Figure 4.1 is to be operated using a flow control policy that does not allow traffic to be lost (due to buffer overflow) at stage 2. This can obviously be done by restricting the flow from the stage 1 nodes whenever the buffer at stage 2 is full. Therefore all

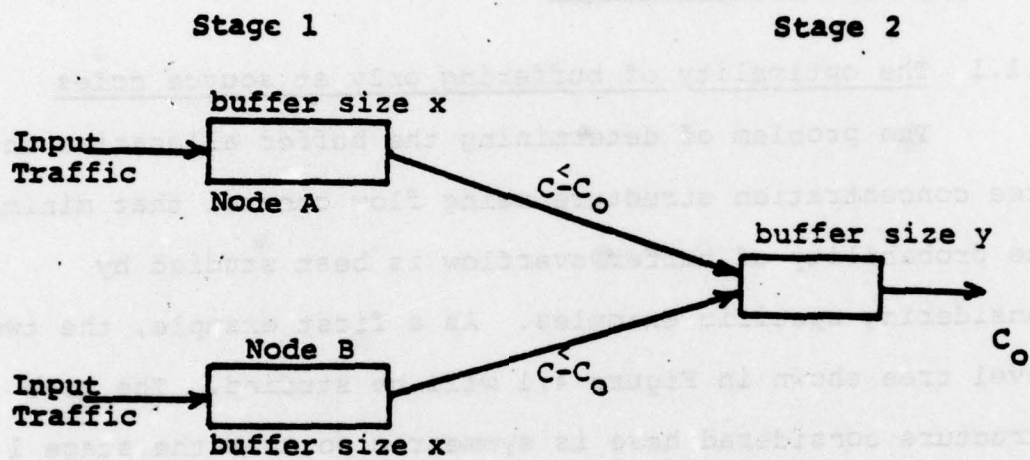

FIGURE 4.1 - Two level tree example.

overflows will occur at stage 1. It will be assumed that there is an instantaneous controller that observes the state of the entire tree and carries out the flow control policy. For the class of all such flow control policies, the problem now is to find the buffer allocation and flow control that minimizes the probability of buffer overflow for the system, subject to the constraint that $2x + y \leq v$, i.e. that the total buffer size is $\leq v$. In the discussion that follows it will be shown that the buffer allocation is $x = v/2$; $y = 0$ is the desired allocation. This allocation can be determined without first specifying the flow control policy exactly.

Before proceeding with the main result, it is necessary to make an observation about the service discipline at stage 2. Note that as long as the service discipline at stage 2 is work conserving (data is sent over the output channel whenever possible) the choice of the exact service discipline there cannot effect the probability of buffer overflow at the input stage to the system. Therefore, for convenience, the service discipline at stage 2 that will be used is the one which always keeps the number of bits from streams A and B (the two input nodes) that are at stage 2 equal. It is possible to do this in a work conserving manner without effecting the stage 1 nodes. To see that this is true, note that the contents of the stage 2 buffer increase only when traffic from both streams A and B is entering the buffer.

During times of buffer increase it is therefore possible to keep the number of bits from streams A and B equal at stage 2 independent of the rule used to determine when or how much traffic is sent from the source nodes. Clearly, it is also possible to do this when the buffer contents of stage 2 are remaining constant or decreasing. This service discipline at stage 2 therefore places no restrictions on the operation of the stage 1 nodes that could effect the probability of buffer overflow there.

The following can now be shown:

Let $t = 0$ be the start of a busy period for a tree structure as shown in Figure 4.1. Also let $R_A(t)$ and $R_B(t)$, $t \geq 0$, be the empty buffer available at nodes A and B respectively, given that there have been no overflows between time 0 and t. Then, using a flow control rule that allows no overflows at stage 2, the buffer allocation that maximizes both $R_A(t)$ and $R_B(t)$ for all $t > 0$ and $2x + y \leq v$ is $x = v/2$; $y = 0$.

The proof of this will be done by comparing the two systems shown in Figure 4.2. System 1 is the proposed optimal system while System 2 is any other symmetric system. System 2 will be assumed to be operating using an optimal flow control policy for its particular buffer configuration. System 1 will be assumed to be operating in a way such that the total buffer contents in it are the same as in System 2.

a. System 1

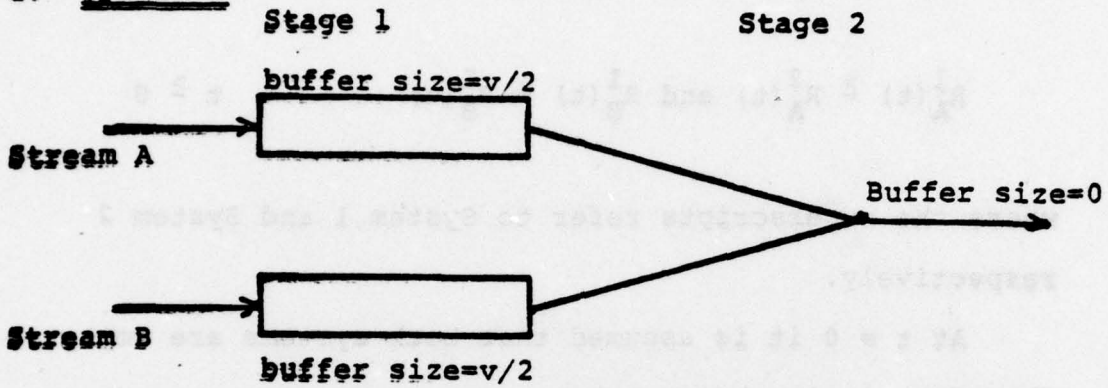

b. System 2

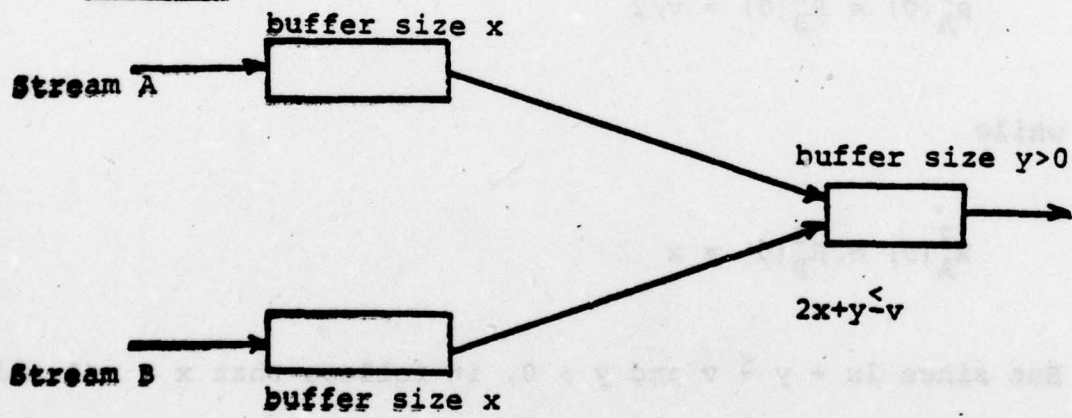

FIGURE 4.2 - Two possible buffer allocations

This can be done from $t = 0$ until the first buffer overflow in either system,[†] which is the time period of interest here. For this time period it will be shown that

$$R_A^1(t) \geq R_A^2(t) \text{ and } R_B^1(t) \geq R_B^2(t) \quad t \geq 0$$

where the superscripts refer to System 1 and System 2 respectively.

At $t = 0$ it is assumed that both systems are empty. Therefore it is obvious that

$$R_A^1(0) = R_B^1(0) = v/2$$

while

$$R_A^2(0) = R_B^2(0) = x$$

But since $2x + y \leq v$ and $y > 0$, it follows that $x < v/2$ and therefore

$$R_A^1(0) > R_A^2(0) \text{ and } R_B^1(0) > R_B^2(0)$$

[†]This will become apparent later in the proof.

For a time $t > 0$, let $a_T(t)$ and $b_T(t)$ be the number of bits from traffic streams A and B that are in the system. Similarly, let $a_2(t)$ and $b_2(t)$ be the number of bits at the second stage of System 2. From the use of the service discipline at stage 2 that keeps the number of bits from streams A and B equal, it follows that

$$a_2(t) = b_2(t) \leq v/2$$

Note that this implies that $a_T(t)$ and $b_T(t)$ for System 2 are both $< v/2$. Therefore System 1 can be operated in such a way that, before the first overflow, it always has the same $a_T(t)$ and $b_T(t)$ as System 2.

In order to compare System 1 and System 2 for $t > 0$, it is necessary to determine exactly where the stored traffic bits are located. Assume that there are $a_T(t)$ and $b_T(t)$ bits in both systems. Then for System 1 it is easy to see that this traffic must be stored as shown in Figure 4.3. From this storage configuration it follows that

$$R_A^1(t) = v/2 - a_T(t) \quad t > 0$$

$$R_B^1(t) = v/2 - b_T(t) \quad t > 0$$

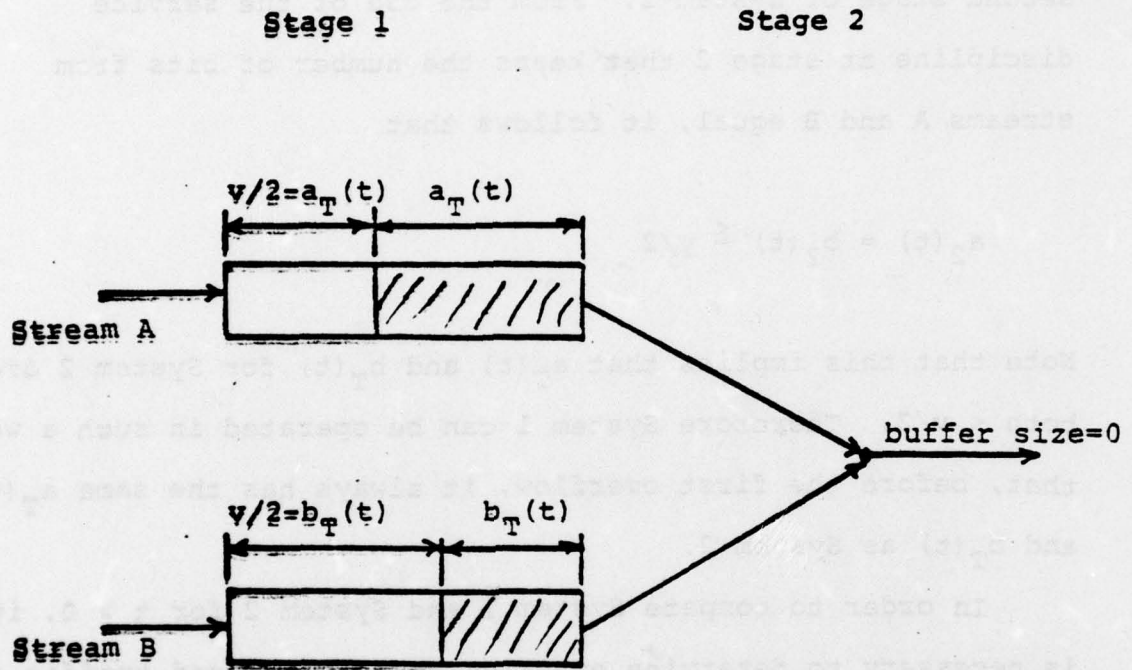

FIGURE 4.3 - Storage of traffic in System 1

For System 2 the location of the stored bits is not known exactly. However, it can be shown that even if they are in the best possible locations, System 2 will not perform better than System 1. There are two situations that need to be examined for System 2.

The first case to be considered is when both $a_T(t)$ and $b_T(t)$ are $\geq y/2$. Then the best possible arrangement of bits in System 2 is as shown in Figure 4.4a. For this case then

$$\begin{aligned}
 R_A^2(t) &= x = (a_T(t) - y/2) \\
 &= x + y/2 = a_T(t) \\
 &= v/2 = a_T(t) \qquad \text{when } 2x + y = v
 \end{aligned}$$

Similarly

$$R_B^2(t) = v/2 = b_T(t)$$

Therefore in this case System 1 and System 2 have the same $R_A(t)$ and $R_B(t)$,

The second case to be considered is when either 1) $a_T(t) < y/2$ and $a_T(t) < b_T(t)$; or 2) $b_T(t) < y/2$ and $b_T(t) < a_T(t)$. Since the system is symmetric, these two conditions are equivalent. The best possible arrangement of bits in

a. $a_T(t)$ and $b_T(t)$ both $\geq y/2$

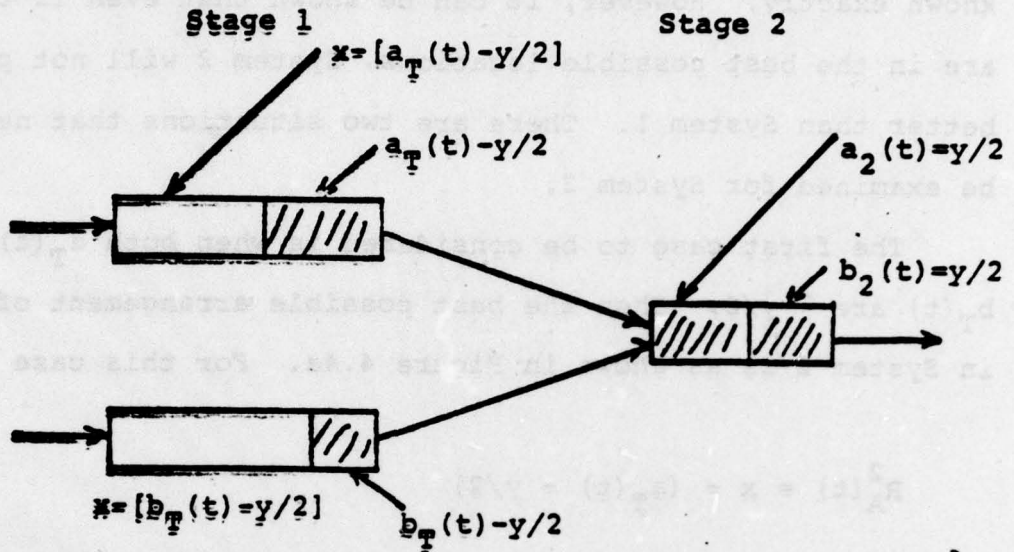

b. $a_T(t) < y/2$ and $b_T(t) > a_T(t)$

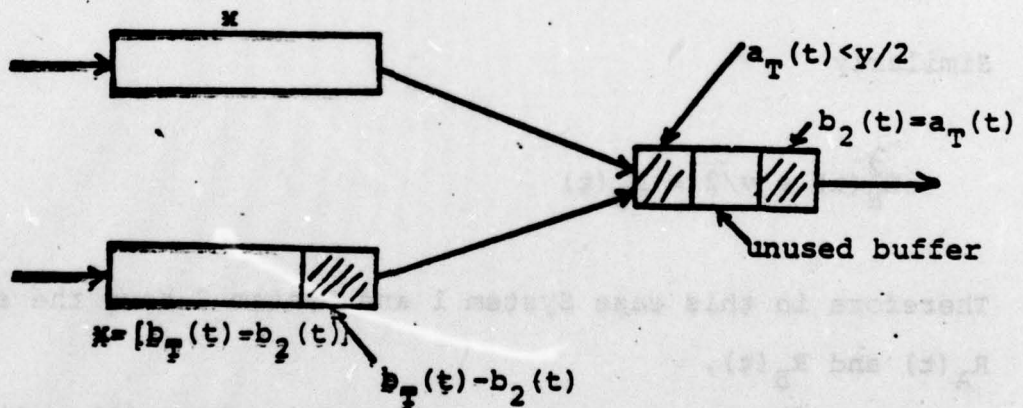

FIGURE 4.4 - Storage of traffic in System 2

System 2 for the first of these conditions is shown in Figure 4.4b. As shown, the fact that $a_2(t) = b_2(t) < y/2$ causes some unused buffer space at stage 2. The result is that

$$R_A^2(t) = x - (a_T(t) - a_2(t)) < x - (a_T(t) - y/2) = R_A^1(t)$$

and

$$R_B^2(t) = x - (b_T(t) - b_2(t)) < x - (b_T(t) - y/2) = R_B^1(t)$$

The analysis of the case $b_T(t) < y/2$ and $b_T(t) < a_T(t)$ is similar. Therefore

$$R_A^1(t) \geq R_A^2(t) \text{ and } R_B^1(t) \geq R_B^2(t) \quad t \geq 0$$

Q.E.D.

What has been shown is that from the start of a busy period until the first overflow in the system, it is better to have all buffers at source nodes. Maximizing $R_A(t)$ and $R_B(t)$ over this time period corresponds to minimizing the probability of at least one buffer overflow in a busy period considered in the previous chapters. The proof does not extend past the first overflow because after that, it is not possible to assume that the number of bits stored in

Systems 1 and 2 is the same. However, if the traffic arrival process at source nodes has a uniform arrival rate for all time, there is reason to believe that System 1 has a lower overall probability of buffer overflow and hence a higher throughput. This will be apparent in the example in Section 4.1.3.

The above example is a special case in that it is symmetric, has only two source nodes and has an interstage communication capacity $\leq C_0$, the tree output capacity. It is now logical to ask if the result can be extended to other concentration trees.

The last restriction, the restriction on interstage channel capacity, is central to the proof just given. If this is not true, the service discipline at stage 2 that keeps $a_2(t)$ and $b_2(t)$ equal effects the probability of overflow at stage 1. To see this consider the arrival of a message into an empty system. If the internal capacity $C > C_0$, a queue of only one type of message (A or B) will build up at stage 2 unless the flow rate out of stage 1 is restricted to C_0 . Such a restriction at the source node would effect the probability of overflow there. Note that when the interstage capacity is $> C_0$, the buffer at stage 2 can be effectively used when traffic of only one type is in the system. This is not true otherwise and therefore one would expect that as the interstage capacity becomes large with respect to C_0 , it becomes optimal to place some buffers at stage 2.

If the condition of symmetry is removed from the problem, the result that it is best to place all buffers at source nodes will still hold. This can be seen by comparing two systems as shown in Figure 4.5. It can be shown that System 1 is better than System 2 by using the same technique that was used for the symmetric case. Therefore, no matter what the optimal allocation x_A and x_B with $y > 0$, the allocation $x_A + y/2$ and $x_B + y/2$ at the source nodes will be better.

The same technique of proof cannot be extended to trees with more than two input nodes. The reason for this is illustrated in Figure 4.6. With more than two input nodes, the traffic from any node is still restricted to occupying less than half of the stage 2 buffer because of the service discipline assumed there. However, for certain buffer contents, this allows for an arrangement of bits at stage 2 such that two inputs effectively use the buffer there and thereby relieve congestion at source nodes. For the case illustrated in Figure 4.6 the result of this is that

$$R_A^1 > R_A^2 \quad \text{but} \quad R_B^1 < R_B^2 \quad \text{and} \quad R_C^1 < R_C^2$$

Therefore it cannot be argued that System 1 has a lower $\text{Pr}(\text{overflow})$.

a. System 1

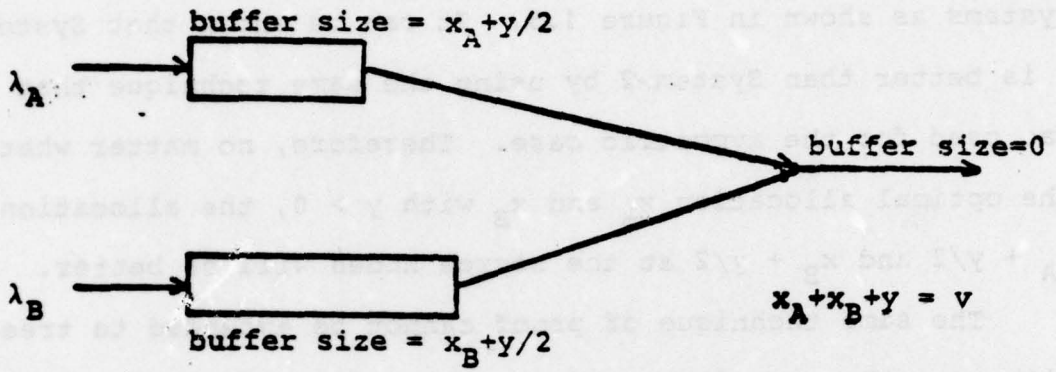

b. System 2

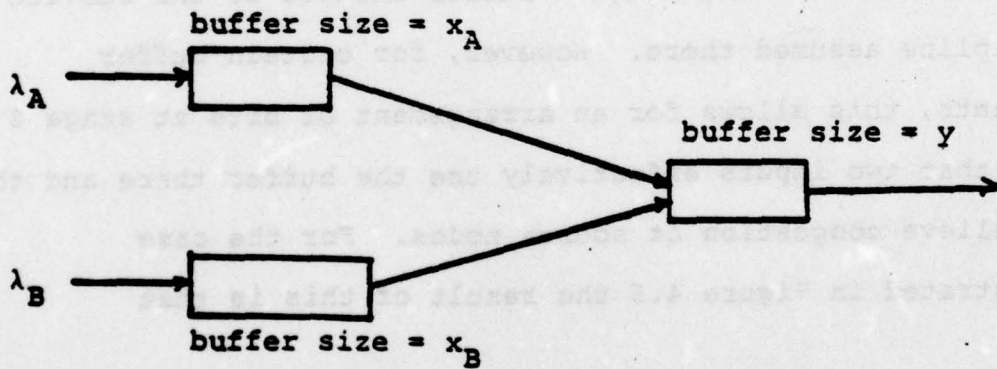
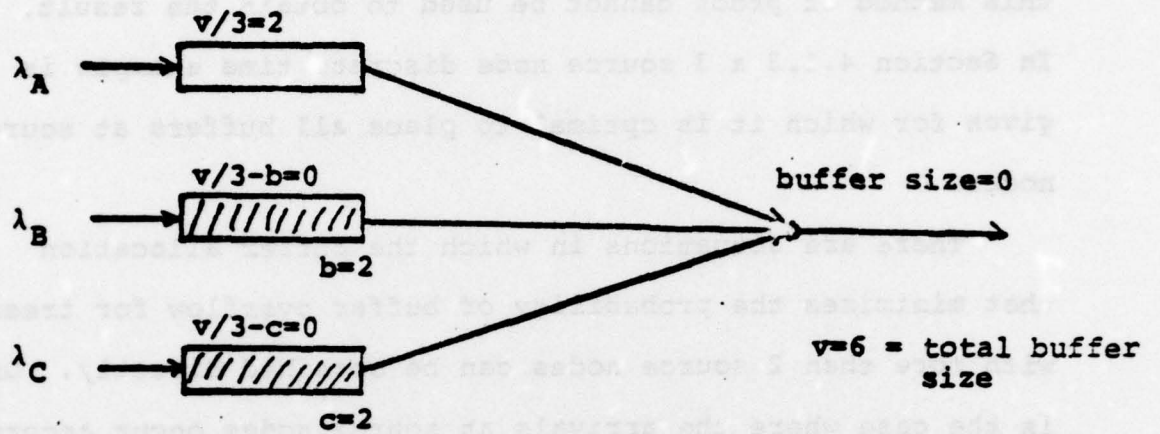

FIGURE 4.5 - Unsymmetric concentration trees

a. System 1



b. System 2

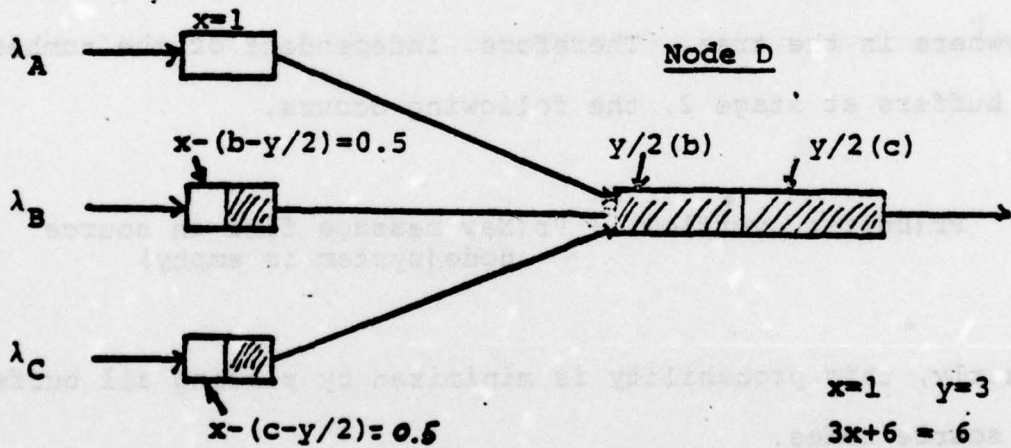

FIGURE 4.6 - A three source node tree

This does not disprove the optimality of placing all buffers at source nodes for this example. It only shows that this method of proof cannot be used to obtain the result. In Section 4.1.3 a 3 source node discrete time example is given for which it is optimal to place all buffers at source nodes.

There are situations in which the buffer allocation that minimizes the probability of buffer overflow for trees with more than 2 source nodes can be obtained directly. One is the case where the arrivals at source nodes occur according to a Poisson process with rate $\lambda \rightarrow 0$ and instantaneous (not gradual) input. Since $\lambda \rightarrow 0$, there is rarely any congestion anywhere in the tree. Therefore, independent of the number of buffers at stage 2, the following occurs.

$$\Pr(\text{Buffer overflow}) \rightarrow \Pr(\text{New message fits in source node} \mid \text{system is empty})$$

Clearly, this probability is minimized by placing all buffers at source nodes.

The above case ($\lambda \rightarrow 0$) depends greatly on the fact that the arrivals occur instantaneously. In Section 4.1.3 it will be shown that if the arrivals are more gradual in nature, it is possible to have a situation in which some buffering at stage 2 is optimal. Therefore it is not always optimal

to place all buffers at source nodes. This section has shown though that it is sometimes optimal and therefore it is worthwhile examining the flow control problem when all buffers are at source nodes.

4.1.2 Flow control when all buffers are at source nodes

The previous section showed that in certain cases it is optimal to place all buffers at source nodes in a concentration tree. The method used to obtain this result did not specify the specific flow rule that should be used with this buffer allocation. Consider again the system in Figure 4.1. If there is no buffer at stage 2, then clearly the output rates of nodes A and B must be controlled so that their total output rate is $\leq C_0$. Since the objective is to minimize overflows, the flow rule should consider the current buffer contents of the source nodes and give priority to the node most likely to overflow next. If one assumes that the input rates are known or have been estimated, then the probability of overflow in the next Δt time unit can be calculated for each node. The node with the largest overflow probability can then be allowed to send at rate C_0 . This node retains the allocation until there is another node with a higher probability of overflow in the next Δt . If one uses Poisson input model with input rate λ , this probability of overflow in the next Δt , $0 < \Delta t \ll 1$, is

Pr(overflow next Δt) = Pr(message arrives in Δt and
has length $h >$ remaining
buffer size)

$$= \lambda \Delta t \int_{h=x_m-x(t)}^{\infty} \mu e^{-\mu h} dh$$

where x_m is the buffer size, $x(t)$ is the current buffer content and μ^{-1} is the mean message length (assume exponentially distributed). For small Δt , $\lambda \Delta t$ is the probability of an arrival in a Poisson process [DRAKE 67].

The flow rule described above is a myopic control policy. This means that it seeks to optimize over the immediate future. The question now is whether this type of rule produces the minimum overall probability of overflow. This problem is being studied by Yee [YEE 76] using discrete time, discrete state space models and Markovian Decision Theory [HOWD 71]. He has found for some examples that myopic policies are indeed optimal for maximizing the expected time between overflows. This is the same as minimizing the probability of overflow. Yee's results are for specific examples and therefore an open question is whether his results can be generalized. If so, flow control for concentration trees with all buffers at source nodes would be greatly simplified.

The flow control rule used here assumes that there is a global controller with knowledge of the state of all nodes. In an actual network, this controller would logically be located at stage 2 so that it could easily collect the

state information from the source nodes and send the flow allocations back to them. The transmission of control information that is required for this has not been included in the model presented here. If control information is sent frequently, it may become a significant part of the total traffic and would be important to include. There is, however, a scheme of transmitting state information to stage 2 that does not introduce extra overhead. The idea, due to Wozencraft,[†] is to use a round robin service discipline at each of the source nodes. The round robin discipline sends a fixed length part of each message at the node each time the node is allowed to send to stage 2. The stage 2 node can then determine the queue size at the source node by counting the number of blocks of data in one round robin scan of a source node. In this way the source state information is not sent as an extra message.

One final point about controlling a tree with all source buffers is that if the control is not instantaneous, some buffering may need to be at stage 2 to account for the delay in turning various source nodes on and off.

[†]Personal communication 1977.

4.1.3 The effect of gradual inputs

The optimality of placing all buffers at source nodes was shown in Section 4.1.1 for a certain case with Poisson traffic sources. If the traffic sources are not Poisson, but rather more gradual in nature, this result may no longer hold. The following discrete time example illustrates this point. The discrete time example is used because it can be easily analyzed and yet provides the relevant insight into the problem.

Figure 4.7 shows two concentration trees that will be compared. Each contains four fixed length buffers and the question to be answered is which gives the lower probability of overflow when operated with a flow control rule that does not allow overflows at stage 2. The systems operate in discrete time. The basic time unit is the interval T illustrated in Figure 4.8. At the beginning of an interval, messages arrive at the source nodes. During the interval exactly one message can be sent over each communication channel in the tree. This means that at most one message can be sent over the tree output channel during an interval T .

Two different arrival processes will be studied for these systems. In Process 1, for each time interval T , the number of messages that arrive at each source node is a Poisson random variable with parameter λ . This means that for each source node

a. System 1

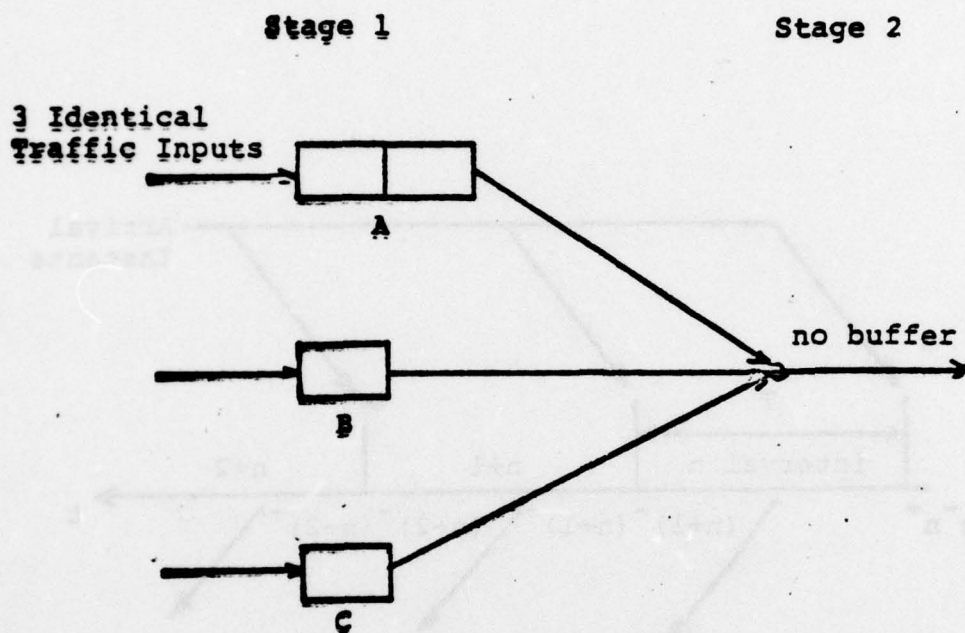

b. System 2

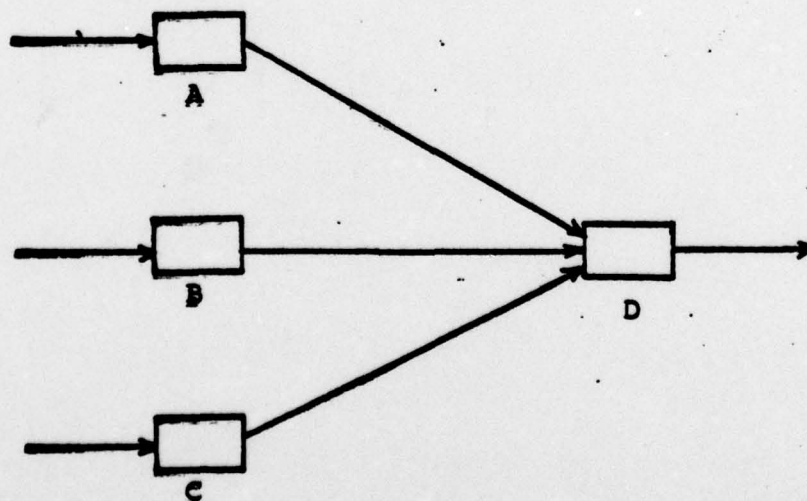

FIGURE 4.7 - Two concentration trees to be compared

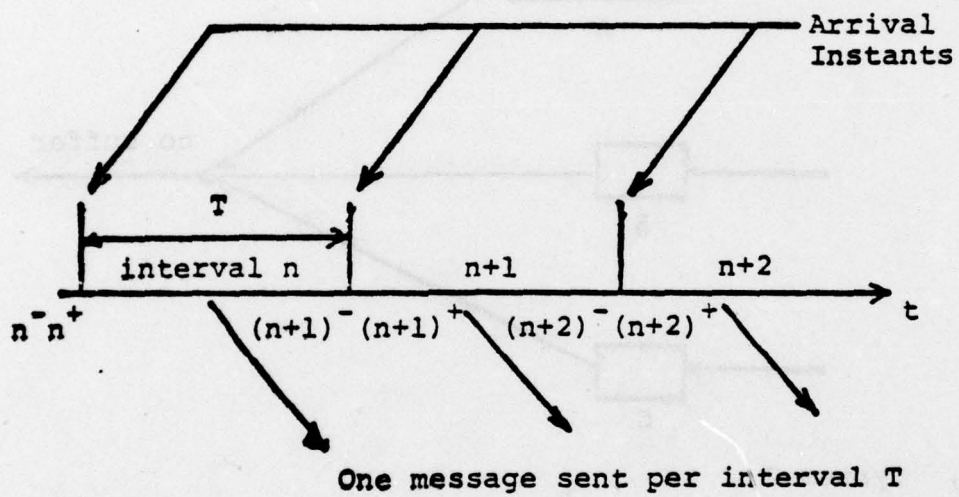

FIGURE 4.8 - Time intervals in the discrete time system

$$\Pr(m \text{ messages arrive}) = q_m^1 = \frac{(\lambda T)^m e^{-\lambda T}}{m!} \quad m=0,1,2,3,\dots$$

In arrival Process 2 only 0,1 or 2 messages can arrive in each interval T at each of the nodes. The probabilities associated with these arrivals at each node will be denoted by

$$\Pr(m \text{ messages arrive}) = q_m^2 \quad m=0,1,2$$

The arrivals in each interval are independent so that the entire system can be modeled as a Markov chain. The states of the chain are specified by the number of messages at each node. The states for the two systems are listed in Tables 4.1 and 4.2. As shown in the tables, one must be specific about exactly when in time a state is referred to. Two times are used in the analysis here. The first, indexed by the interval number n^- , is just prior to the arrival of the new messages in the nth interval. The second, indexed by n^+ , is just after the arrival of the new messages. Let $x(n)$ be the state number at time n ($n=1,2,3,\dots$) (either n^+ or n^-) and let $\pi_i(n) = \Pr(x(n)=i)$ be the state occupancy probability of state number i . Then the problem to be solved is the determination of the vector of steady state occupancy probabilities

$$\bar{\pi}^+ = \lim_{n \rightarrow \infty} \bar{\pi}(n)^+$$

In order to solve for the vector $\bar{\pi}^+$, the matrix of one step transition probabilities, \bar{P} , must be determined. The elements of \bar{P} are $p_{ij} = \Pr(x(n+1)^+ = j | x(n)^+ = i)$. This matrix can be determined by examining the state transitions due to message arrivals and those due to message departures separately. From time n^+ to $(n+1)^-$, the only state transitions that can occur are those due to message departures. Which transition occurs depends only on the starting state at time n^+ and the flow rule used. The flow rule can be deterministic when conditioned on the starting state. For the simple example here, it is easy to choose the flow rule that minimizes the probability of buffer overflow. The flow rule transitions are given in Tables 4.1 and 4.2. These deterministic transitions can be represented by a transition matrix \bar{P}^+ whose elements are $p_{ij}^+ = \Pr(x(n+1)^- = j | x(n)^+ = i)$. The following then holds.

$$\bar{\pi}(n+1)^- = \bar{\pi}(n)^+ \bar{P}^+$$

Now consider transitions from time $(n+1)^-$ to $(n+1)^+$. These transitions result only from message arrivals. Let \bar{P}^- be the transition matrix with elements $p_{ij}^- = \Pr(x(n)^+ = j | x(n)^- = i)$. The elements p_{ij}^- can be expressed in terms of q_m^j for the two systems and the two arrival processes considered here. Tables 4.3 and 4.4 give the expressions for these elements p_{ij}^- . The following now holds.

TABLE 4.1

State Definitions and Flow Rules for System 1

State Number i	Description (Number of Messages at Nodes)			State Number at $(n+1)$ if $x(n)^+=i$
	A	B	C	
1	0	0	0	1
2	0	0	1	1
3	0	1	0	1
4	0	1	1	2
5	1	0	0	1
6	1	0	1	5
7	1	1	0	5
8	1	1	1	6
9	2	0	0	5
10	2	0	1	9
11	2	1	0	9
12	2	1	1	8

TABLE 4.2

State Definitions and Flow Rules for System 2

State Number i	Description (Number of messages at nodes)				State Number at $(n+1)^-$ if $x(n)^+=i$
	A	B	C	D	
1	0	0	0	0	1
2	0	0	0	1	1
3	0	0	1	0	1
4	0	0	1	1	2
5	0	1	0	0	1
6	0	1	0	1	2
7	0	1	1	0	2
8	0	1	1	1	4
9	1	0	0	0	1
10	1	0	0	1	2
11	1	0	1	0	2
12	1	0	1	1	4
13	1	1	0	0	2
14	1	1	0	1	6
15	1	1	1	0	4
16	1	1	1	1	8

TABLE 4.3

State Transitions Due to Arrivals for System 1

Process 1

$$Q = q_0^1$$

$$P = q_1^1$$

$$P2 = 1 - Q - P$$

Process 2

$$Q = q_0^2$$

$$P = q_1^2$$

$$P2 = q_2^2$$

$$PB(i,j) = p_{i,j}^-$$

- PB(1,1) = Q*Q*Q
- PB(1,2) = Q*Q*(1.0-Q)
- PB(1,3) = Q*Q*(1.0-Q)
- PB(1,4) = Q*(1.0-Q)*(1.0-Q)
- PB(1,5) = Q*Q*P
- PB(1,6) = Q*P*(1.0-Q)
- PB(1,7) = Q*P*(1.0-Q)
- PB(1,8) = P*(1.0-Q)*(1.0-Q)
- PB(1,9) = P2*Q*Q
- PB(1,10) = P2*Q*(1.0-Q)
- PB(1,11) = P2*Q*(1.0-Q)
- PB(1,12) = P2*(1.0-Q)*(1.0-Q)
- PB(2,2) = Q*Q
- PB(2,4) = Q*(1.0-Q)
- PB(2,6) = P*Q
- PB(2,8) = P*(1.0-Q)
- PB(2,10) = P2*Q
- PB(2,12) = P2*(1.0-Q)
- PB(5,5) = Q*Q*Q
- PB(5,6) = Q*Q*(1.0-Q)
- PB(5,7) = Q*Q*(1.0-Q)
- PB(5,8) = Q*(1.0-Q)*(1.0-Q)
- PB(5,9) = (1.0-Q)*Q*Q
- PB(5,10) = (1.0-Q)*Q*(1.0-Q)
- PB(5,11) = (1.0-Q)*Q*(1.0-Q)
- PB(5,12) = (1.0-Q)*(1.0-Q)*(1.0-Q)
- PB(6,6) = Q*Q
- PB(6,8) = Q*(1.0-Q)
- PB(6,10) = (1.0-Q)*Q
- PB(6,12) = (1.0-Q)*(1.0-Q)
- PB(8,8) = Q
- PB(8,12) = 1.0-Q
- PB(9,9) = Q*Q
- PB(9,10) = Q*(1.0-Q)
- PB(9,11) = Q*(1.0-Q)
- PB(9,12) = (1.0-Q)*(1.0-Q)

TABLE 4.4

State Transitions due to Arrivals for System 2

Process 1

$$Q = q_0^1$$

$$P = 1 - Q$$

Process 2

$$Q = q_0^2$$

$$P = 1 - Q$$

$$PB(i,j) = P_{i,j}^-$$

$$PB(1,1) = Q*Q*Q$$

$$PB(1,3) = Q*Q*P$$

$$PB(1,5) = Q*Q*P$$

$$PB(1,7) = Q*P*P$$

$$PB(1,9) = Q*Q*P$$

$$PB(1,11) = Q*P*P$$

$$PB(1,13) = Q*P*P$$

$$PB(1,15) = P*P*P$$

$$PB(2,2) = Q*Q*Q$$

$$PB(2,4) = Q*Q*P$$

$$PB(2,6) = Q*Q*P$$

$$PB(2,8) = Q*P*P$$

$$PB(2,10) = Q*Q*P$$

$$PB(2,12) = Q*P*P$$

$$PB(2,14) = Q*P*P$$

$$PB(2,16) = P*P*P$$

$$PB(4,4) = Q*Q$$

$$PB(4,8) = Q*P$$

$$PB(4,12) = Q*P$$

$$PB(4,16) = P*P$$

$$PB(6,6) = Q*Q$$

$$PB(6,8) = Q*P$$

$$PB(6,14) = Q*P$$

$$PB(6,16) = P*P$$

$$PB(8,8) = Q$$

$$PB(8,16) = P$$

$$\Pi(n+1)^+ = \Pi(n+1)^- \bar{P}^-$$

$$= \Pi(n)^+ \bar{P}^+ \bar{P}^-$$

$$= \Pi(n)^+ \bar{P}$$

The desired transition matrix is then the product of \bar{P}^+ and \bar{P}^- .

The well known result that if the chain is ergodic

$$\lim_{n \rightarrow \infty} \Pi(n)^+ = \Pi^+ = \Pi^+ \bar{P} \quad [\text{PRAZ 62}]$$

can then be applied to find the desired steady state occupancy probabilities. Once Π^+ is known, it is easy to determine which system has the lower probability of buffer overflow. Note that for both systems, π_1^+ is the probability that the system is empty just after the time for new arrivals. In all other states there is a throughput of one message in the interval T . Therefore the expected throughput per interval T is $1 - \pi_1^+$. Since the same traffic is being applied to both systems, it follows directly that the system with the higher throughput has the lower probability of buffer overflow.

Tables 4.5, 4.6 and 4.7 give the system throughputs for different input processes. Table 4.5 gives the results for Process 1, the Poisson input. The results show that it is best to place all buffers at source nodes for all values of the traffic arrival rate λ . Table 4.6 gives the results

for Process 2 when only q_0^2 and q_1^2 are nonzero. This means that at most one message can arrive at each source node during an interval T . This is a very gradual input. In this case, placing all buffers at source nodes is not optimal for any arrival rate. What has happened is that enough burstiness has been removed from the arrival process so that is more important to place some buffering at stage 2 where it is more useful in preventing overflows due to multiple arrivals in one interval T .

It is possible to explore how much burstiness is needed in the traffic to make it optimal to place all buffers at source nodes by using the Process 2 model. The results in table 4.7 give an indication that not very much burstiness is needed. The case examined there has $q_1^2 = 0.2$ while q_2^2 is varied over a wide range. As q_2^2 , the probability of 2 arrivals, is increased, the burstiness of the input traffic increases. For q_2^2 very small (0 and 0.001) it is not optimal to place all buffers at source nodes. However, when q_2^2 becomes larger (0.01, 0.05 and 0.1) it is optimal. In conclusion, it is not always optimal to use all source buffering.

TABLE 4.5

Expected Throughput Using Input Process 1

T = 1.0

λ	System 1	System 2
.01	.029899	.029850
.1	.288896	.285283
.5	.9549905	.9524518
1.0	.999728889	.999719148
2.0	$1 - (.343404 \times 10^{-7})$	$1 - (.345133 \times 10^{-7})$

TABLE 4.6

Expected Throughput Using Input Process 2 with $q_2^2=0$

T=1.0

q_1^2	System 1	System 2
0.1	.298816	.29974
0.2	.586201	.59136
0.3	.824173	.830993
0.4	.9545326	.9572018
0.5	.9929578	.993333

Table 4.7

Expected Throughput Using Input Process 2

ρ_2	System 1	System 2
0.000	.5862	.591361
0.001	.589626	.594133
0.010	.619821	.618851
0.050	.738958	.722383
0.100	.850615	.830993

4.2 The Queueing Analysis of a Concentration Tree

4.2.1 An approximate analysis of a two level tree

The queueing analysis of buffer stages coupled by flow control rules is a difficult problem if the system is not operating in discrete time with fixed length messages as in Section 4.1.3. It is often possible to specify reasonable flow rules, but usually not possible to analytically determine the performance of the network when the rules are used. This section develops an approximate analysis for a simple example that shows some techniques for overcoming this problem.

The tree to be analyzed is shown in Figure 4.9. The input nodes A and B in this example are receiving Poisson input streams of messages with exponentially distributed message lengths. These traffic streams are then fed into stage 2 over finite capacity channels. The capacity of these channels is equal to the capacity of the output channel of stage 2 when no flow control is in effect. When buffer C fills and both nodes A and B are in busy periods, the rate of each of the channels between the first level of the tree and stage 2 is reduced to one half the normal rate. This keeps buffer C from overflowing. If buffer C is full and only one stage at the first level has traffic, the rate on the channel between that node and buffer C is kept at the normal rate. This flow rule is essentially what happens if link by link flow control is being achieved by rejecting messages at stage 2 whenever the buffer there is full.

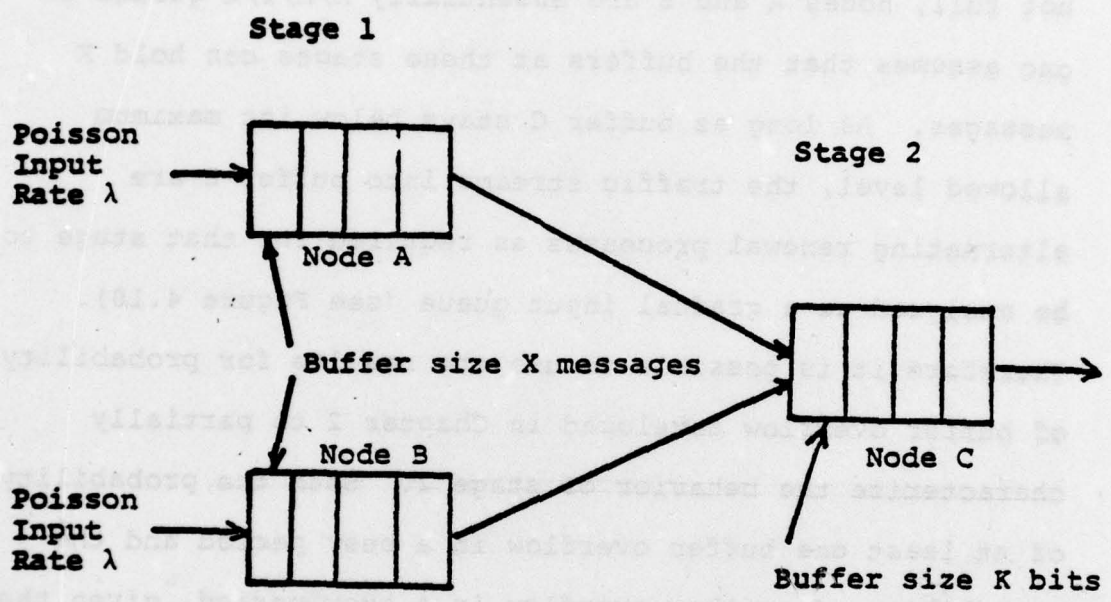
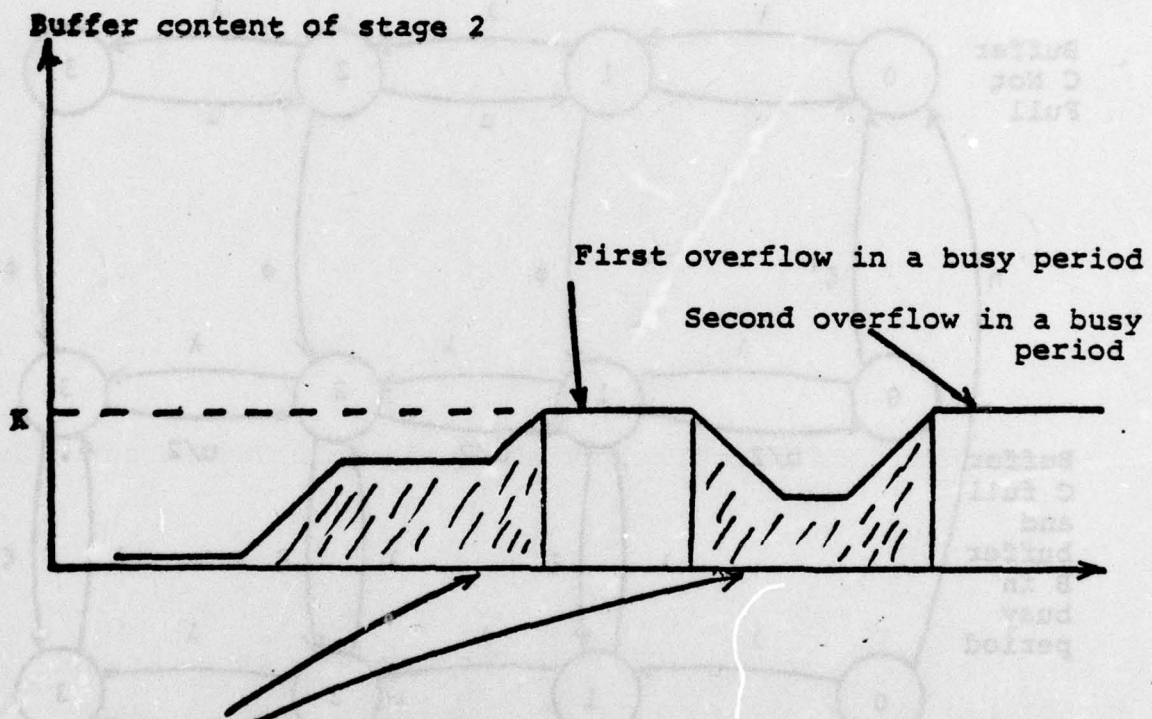

FIGURE 4.9 - Two level tree flow control problem. The buffers at each level are finite. All channels have the same capacity in the absence of flow control.

Even for this simple symmetric example, it has not been feasible to solve for the exact steady state statistics of buffer occupancy and buffer overflow. Therefore the following approximate analysis will be used. When buffer is not full, nodes A and B are essentially M/M/1/X queues if one assumes that the buffers at these stages can hold X messages. As long as buffer C stays below its maximum allowed level, the traffic streams into buffer C are alternating renewal processes as required for that stage to be analyzed as a gradual input queue (see Figure 4.10). Therefore it is possible to use the results for probability of buffer overflow developed in Chapter 2 to partially characterize the behavior of stage 2. Both the probability of at least one buffer overflow in a busy period and the probability of another overflow in a busy period, given that at least one has already occurred will be bounded for stage 2.

Now the behavior of node A will be represented by an approximating continuous time Markov chain. Since nodes A and B are identical, this will also characterize node B. The approximating Markov chain is shown in Figure 4.11. The chain is best understood by considering a typical sequence of buffer operation. Suppose that buffer A is empty and that buffers B and C are in some unknown state, but buffer C is not full. In this condition, the approximating chain is in state $\{1,0\}$. As a busy period starts for buffer A, the



In these sections, the inputs to stage 2 are alternating renewal processes with exponential off times and on times distributed as the busy periods of an M/M/1/X queue

FIGURE 4.10 - Queueing process at stage 2

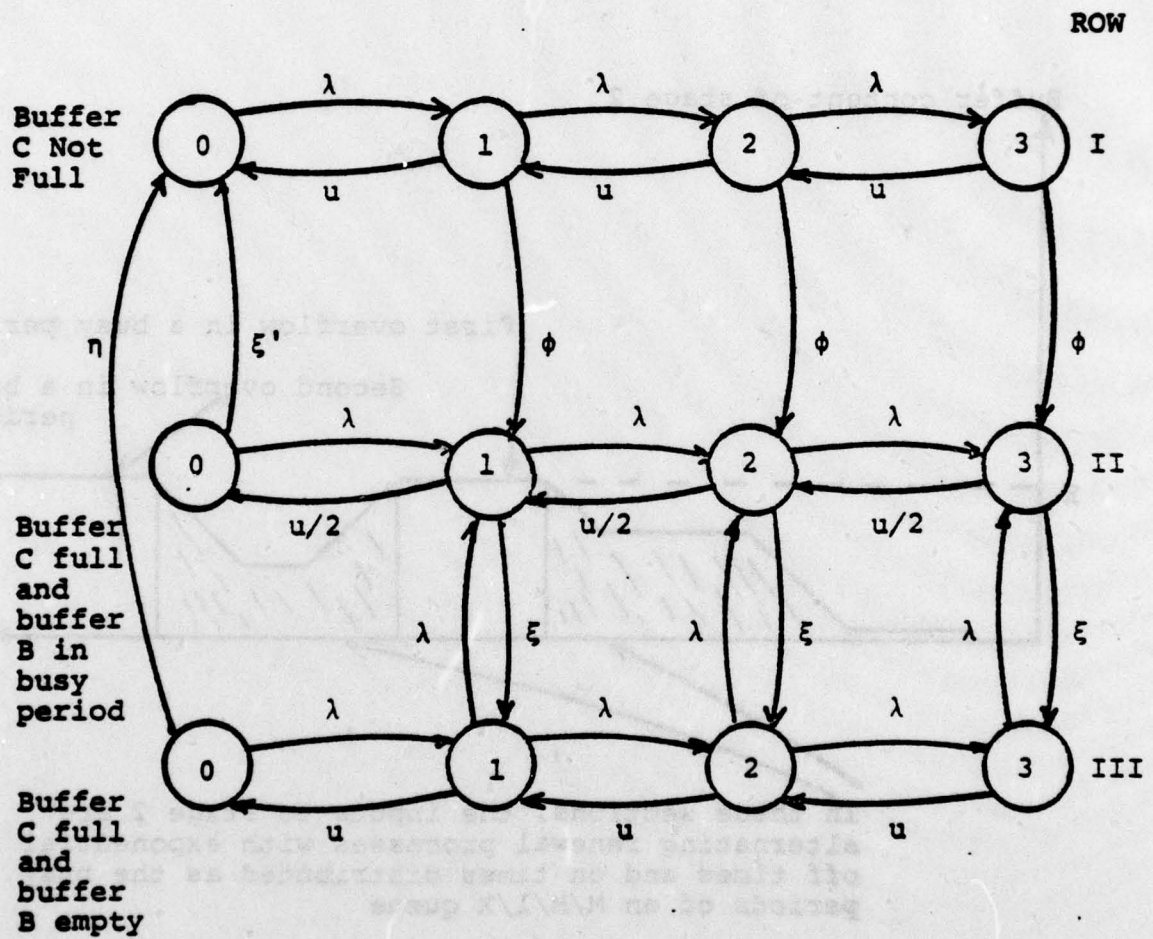

Figure 4.11 - Transition rate diagram for Node A in Figure 4.9. The state numbers represent the number of messages at Node A. The various transition rates are explained in the text.

state changes along row I. At this time, buffer C is not full, so no flow control restrictions are in effect. If buffer C fills during this busy period, the state will change to row II of the approximating chain. In order for buffer C to have filled up, buffer B must be in a busy period and therefore the flow control that reduces the rate of flow from buffers A and B to C to half the normal rate goes into effect.

As long as both buffers A and B are in busy periods, the state of the system will remain in row II. If buffer A goes off before buffer B, the state can change back to $\{I,0\}$. If buffer B goes off before buffer A, the state will change to row III. In row III, the channel between buffer A and buffer C is kept at the normal rate, so that as long as buffer A is in a busy period, buffer C remains full. From row III, transitions can occur back to row II or from state $\{III,0\}$ they can occur back to state $\{I,0\}$.

Given this overall description, the remaining problem is determining the appropriate transition rates. Briefly, these are as follows. Along row I the rates are λ , the rate for the Poisson arrival process, and μ , the rate of service completions for exponentially distributed length messages. The rate of transition from row I to row II, ϕ , is chosen so that the upper bound on the probability of at least one

overflow in a busy period calculated for state 2 is met. The specifics of this calculation and others are given later in this section.

In row II (excluding state $\{II,0\}$) both buffers A and B are in busy periods. The state of buffer A is accounted for explicitly, while that of buffer B is not precisely known. Knowing that buffer B is in a busy period is, however, sufficient to make use of a result on the tail behavior of the busy period distribution of a queue such as buffer B is exponential with a well defined mean. In this case the queue of interest is an M/M/1/X queue with arrival rate λ and mean service time $2/u$. Let ξ^{-1} be the mean of the exponential tail of the busy period distribution of such a queue. Then ξ will be the transition rate used for transitions caused by the busy period of buffer B ending. For a transition from state $\{II,0\}$ due to the ending of a buffer B busy period, the transition rate is ξ' the parameter associated with the busy period tail for an M/M/1/X queue with arrival rate λ and mean service time u^{-1} .

From row III, transitions occur back to row II if buffer B starts a new busy period. If the system reaches state $\{III,0\}$, a transition can be made to state $\{I,0\}$. A transition to state $\{I,0\}$ is taken to approximately represent the end of a busy period of stage 2 without another overflow. Therefore the quantity $\eta/(\eta+\lambda)$ will be equated with a lower

bound on the probability of not having another overflow in a busy period of buffer C, given that there has already been at least one in this busy period. The specification of the rate η completes the approximating Markov chain.

Specific details are now given for calculating the various rates in the approximating chain. The case in which each stage 1 node has 2 buffers ($X=2$) is used as an illustration. After the transition rates are determined, the chain is analyzed for its steady state occupancy probabilities. The probability of being in states with all node A buffers full is the probability of overflow measure that is of interest here.

A. Determining the transition rate ϕ

The transition rate ϕ is chosen so that in the approximating chain

$$\Pr \left(\begin{array}{l} \text{Go to row II} \\ \text{before going} \\ \text{to (I,0)} \end{array} \middle| \begin{array}{l} \text{Start in} \\ \text{state (I,1)} \end{array} \right) \geq \Pr(\text{Overflow at least} \\ \text{once in stage 2} \\ \text{busy period})$$

This is done because, as illustrated in Figure 4.10, starting flow control (going to row II) corresponds to the stage 2 buffer becoming full. Determining the rate ϕ requires three basic steps.

1. Determine the mean length of the stage 1 M/M/1/X queue busy periods. This can be done using a first passage time analysis for Markov chains as in Section 2.1.2.

For the case $X=2$, the mean busy period length is given by

$$\beta = \mu^{-1} [1 + \lambda/\mu]$$

2. Determine the upper bound on $\text{Pr}(\text{overflow})$ for stage 2 when the two inputs have mean on time β and mean off time λ^{-1} . This can be done by using Equation 2.18. Denote this bound by $\hat{\text{Pr}}(\text{overflow})$.

3. Determine ϕ so that

$$\text{Pr} \left(\begin{array}{l} \text{Go to row II} \\ \text{before going} \\ \text{to } (I,0) \end{array} \middle| \begin{array}{l} \text{Start in} \\ \text{state } (I,1) \end{array} \right) = \hat{\text{Pr}}(\text{overflow})$$

In order to do this, one must solve a trapping problem as illustrated in Figure 4.12 for the case $X=2$. As shown in the Markovian transition rate diagram given in the figure.

$$\text{Pr} \left(\begin{array}{l} \text{Go to row II} \\ \text{before going} \\ \text{to } (I,0) \end{array} \middle| \begin{array}{l} \text{Start in} \\ \text{state } (I,1) \end{array} \right) = \text{Pr} \left(\begin{array}{l} \text{Trap in} \\ \text{row II} \end{array} \middle| \begin{array}{l} \text{Start in} \\ \text{state} \\ (I,1) \end{array} \right)$$

This trapping probability can be determined by system analysis techniques given by Howard [HOWD 71]. For the $X=2$ case the desired trapping probability is given by

$(\mu\phi + \phi^2 + \phi\lambda) / [(\mu + \phi)(\mu + \lambda + \phi - \mu\lambda)]$. The rate ϕ can then be determined from

a. Original Chain

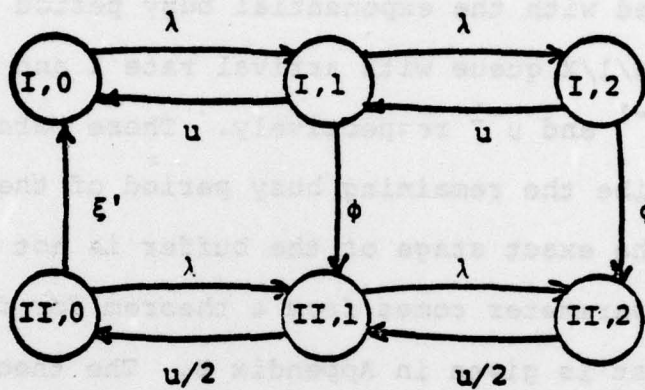

b. Equivalent Trapping Problem

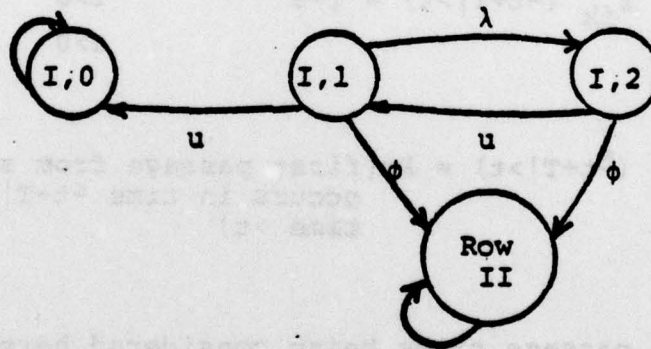

FIGURE 4.12 - Markov chain for determining $\Pr(\text{go to row II before } (I,0) | \text{start in } (I,1))$. The case $x=2$ is illustrated.

$$\frac{(\mu\phi + \phi^2 + \phi\lambda)}{(\mu + \phi)(\mu + \lambda + \phi - \mu\lambda)} = \hat{\text{Pr}}(\text{overflow})$$

B. Determining the rates ξ and ξ'

The parameters ξ^{-1} and ξ'^{-1} are the mean parameters associated with the exponential busy period distribution tails of an M/M/1/X queue with arrival rate λ and mean service times $2\mu^{-1}$ and μ^{-1} respectively. These parameters are used to describe the remaining busy period of the buffer at node B when the exact stage of the buffer is not known. The use of this parameter comes from a theorem for first passage times that is given in Appendix B. The theorem states that for queues such as the M/M/1/X queues considered here

$$\lim_{t \rightarrow \infty} f_{ik} (\leq t+T | > t) = 1 - e^{-aT} \quad \begin{array}{l} T > 0 \\ a > 0 \end{array}$$

Where $f_{ik} (\leq t+T | > t) = \text{Pr}\{\text{first passage from state } i \text{ to } k \text{ occurs in time } \leq t+T | \text{first passage time } > t\}$

The first passage times being considered here are busy periods, i.e., the first passage time from having one customer in the queue to the all empty state. The above result states if that all that is known is that the busy period has been in progress for a long time, then the conditional distribution of the time remaining in the busy

period is exponential with parameter a . It is natural to use the mean of this distribution as the mean time remaining in a busy period of node B, given that all that is known is that a busy period is in progress. Appendix B outlines the derivation of the parameter a . For the $X=2$ examples, a was determined by actually finding the Laplace transform of the busy period distribution for an $M/M/1/X$ queue using the techniques in Section 2.1.2. The parameter a is then the pole of the transform that is closest to the origin. For an $M/M/1/X$ queue with $X=2$ and parameters λ and μ .

$$a = -\left[\frac{-(2\mu + \lambda) + \sqrt{(2\mu + \lambda)^2 - 4\mu^2}}{2} \right]$$

C. Determining the parameter η

The parameter η is used to approximate the effect of multiple overflows in a busy period. Once the system is in state $\{III,0\}$, it has already had at least one overflow in the current busy period and may have another. To account for this, the probability of going directly from state $\{III,0\}$ to state $\{I,0\}$ is equated with a lower bound on the probability of having another overflow in the busy period of buffer C, given that there has already been at least one in this busy period. The probability of going from state $\{III,0\}$ to $\{I,0\}$ is $\eta/(\eta + \lambda)$ and the lower bound that is used is $1 - \hat{Pr}(\text{overflow again} | \text{at least one overflow})$ where the later is given by Equation 2.25.

All transition rates for the Markov chain in Figure 4.10 have now been specified. The remaining problem is to find the steady state occupancy probabilities for the chain. Let $x(t)$ be the state of the system at time $t \geq 0$. Then the desired occupancy probabilities are

$$\pi_j = \lim_{t \rightarrow \infty} \pi_j(t) = \lim_{t \rightarrow \infty} \Pr\{x(t)=j\}$$

These can be found by first solving for the occupancy probabilities in the imbedded discrete time Markov chain. The imbedded chain has one step transition probabilities that are equal to those in the original chain. The difference is that all one step transitions occur in one discrete time unit. Let \bar{P}' be the one step transition probability matrix for the imbedded chain with elements $p'_{ij} = \Pr\{x'(n+1)=j | x'(n)=i\}$ $n=0,1,2,\dots$ where $x'(n)$ is the state of the imbedded chain. Then the relationship between the imbedded chain and the original is that

$$p'_{ij} = \Pr(\text{next state is } j \mid \text{starting state is } i \text{ in the original chain})$$

These probabilities are given in the illustration of the imbedded chain in Figure 4.13. Let $\pi'_i(n) = \Pr\{x'(n)=i\}$ and $\Pi'_i = \lim_{n \rightarrow \infty} \pi'_i(n)$. Then the result that $\Pi' = \Pi' \bar{P}'$ can be used to find the vector of π'_i 's.

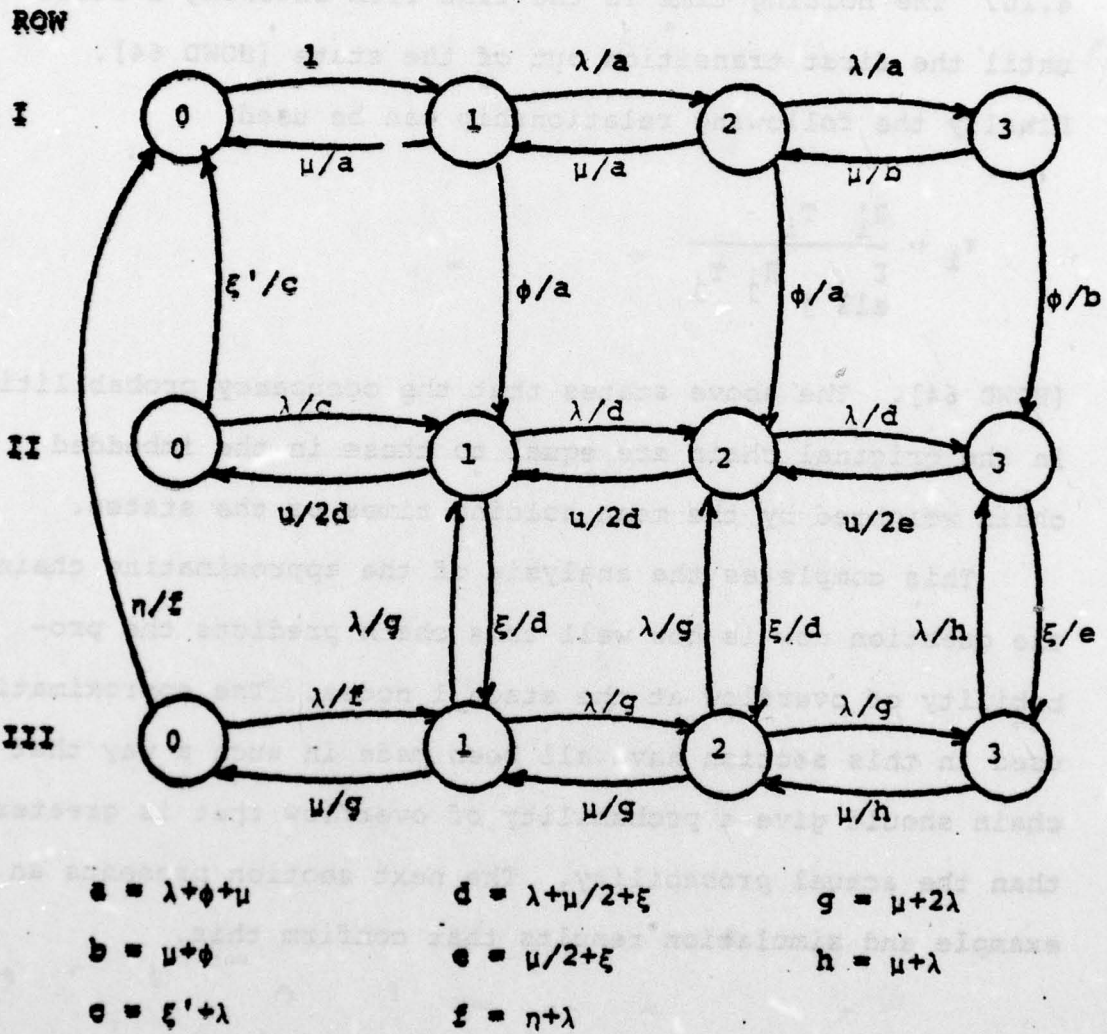

FIGURE 4.13 - Imbedded Markov chain for the chain shown in Figure 4.11. Transition probabilities are shown on the diagram.

Now the occupancy probabilities for the original chain can be found from $\bar{\pi}'$. Each state i in the original chain has a mean holding time $T_i = [\sum_{\text{all } j} r_{ij}]^{-1}$ where the r_{ij} 's are the transition rates from state i to j given in Figure 4.10. The holding time is the time from entering a state until the first transition out of the state [HOWD 64]. Finally the following relationship can be used

$$\pi_i = \frac{\pi'_i T_i}{\sum_{\text{all } j} \pi'_j T_j}$$

[HOWD 64]. The above states that the occupancy probabilities in the original chain are equal to those in the imbedded chain weighted by the mean holding times of the states.

This completes the analysis of the approximating chain. The question now is how well this chain predicts the probability of overflow at the stage 1 nodes. The approximations used in this section have all been made in such a way that the chain should give a probability of overflow that is greater than the actual probability. The next section presents an example and simulation results that confirm this.

4.2.2 An example and simulation verification

The example to be considered has 2 buffers at each stage 1 node ($X=2$). The mean length of messages is $\mu^{-1}=1$ and the maximum rate for all communication channels is 1. The buffer at stage 2 can hold exactly three messages each of length 1.

The probability of overflow at stage 1 predicted by the approximating chain is shown in Figure 4.14 for different arrival rates λ . Also given are the results of a Monte Carlo computer simulation for each of the cases. The simulation techniques were similar to those in Section 3.1.4. The simulation results indicate that the approximating chain indeed consistently gives a larger probability of overflow.

An indication of how settled the simulation results are is given in Figure 4.15. Here the probability of overflow is plotted as a function of the length of the simulation run. The conclusion is that the approximate analysis presented here is indeed useful for obtaining conservative estimates for the probability of overflow when there is coupling between stages of the concentration tree due to flow control.

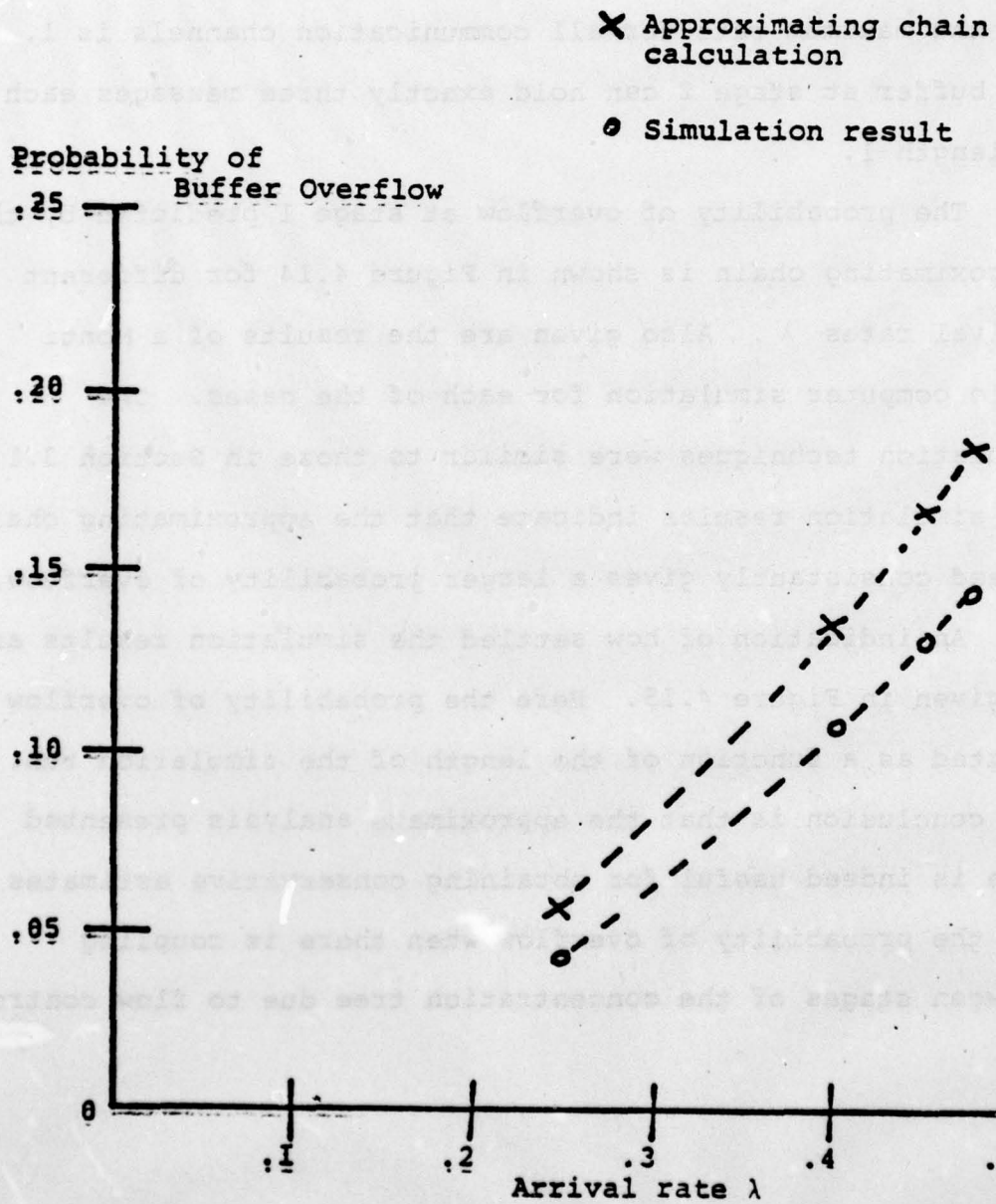

FIGURE 4.14 = Probability of overflow for the concentration tree. $x=2$, $\mu^{-1}=1$, buffer size at stage 2 is 3 and $C=1$.

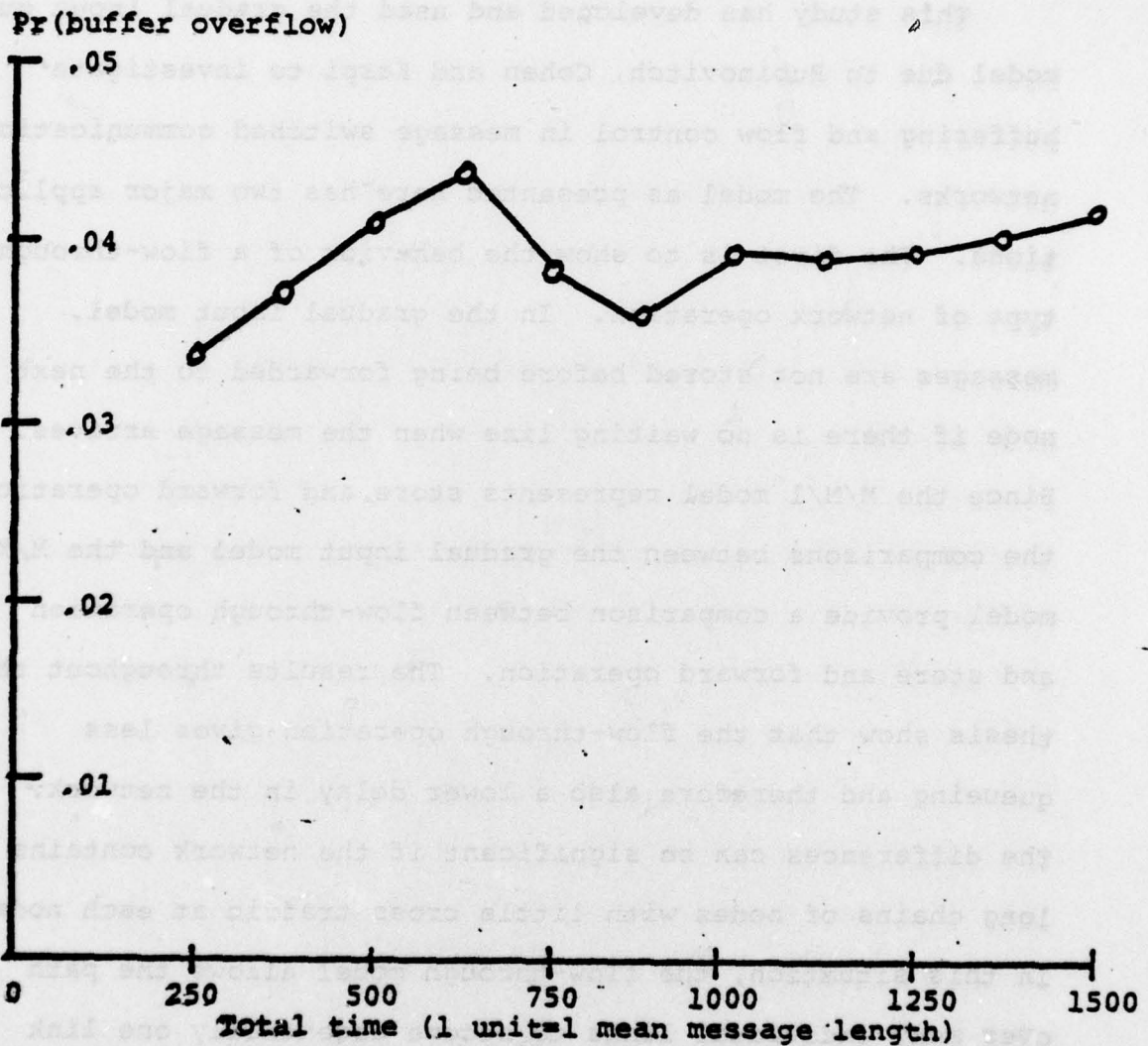

FIGURE 4.15 - Simulation data for result shown in Figure 4.14.
Arrival rate $\lambda = 0.25$.

CHAPTER V - CONCLUSION AND SUGGESTIONS FOR FURTHER RESEARCH

5.1 Conclusion

This study has developed and used the gradual input queue model due to Rubinovitch, Cohen and Kaspi to investigate buffering and flow control in message switched communication networks. The model as presented here has two major applications. The first is to show the behavior of a flow-through type of network operation. In the gradual input model, messages are not stored before being forwarded to the next node if there is no waiting line when the message arrives. Since the M/M/1 model represents store and forward operation, the comparisons between the gradual input model and the M/M/1 model provide a comparison between flow-through operation and store and forward operation. The results throughout the thesis show that the flow-through operation gives less queueing and therefore also a lower delay in the network. The differences can be significant if the network contains long chains of nodes with little cross traffic at each node. In this situation, the flow-through model allows the path over many individual links to become essentially one link when there are no waiting lines at intermediate nodes. The expected delay over this path therefore approaches the time to transmit over one link. In store and forward operation the delay is always at least as large as the sum of the individual transmission times over each link in the path.

Since flow-through operation appears to have theoretical advantages over store and forward operation, a logical question is why it is currently not being used. One major reason is that it does not allow the use of standard link by link protocols. The link by link protocols permit error detection and retransmission on each link. Only end to end error protection can be used in a flow-through network. End to end error protection allows errors to be passed from one link to another in the network. This makes it difficult to guarantee correct network operation since control information as well as user data is sent through the network. For example, if an error occurs in the address of a message, it may not reach the correct destination node.

A second major reason that store and forward operation is being used is that it allows for a straightforward node architecture. The tasks associated with receiving a message over one link are all completed and the message is stored in memory before a request for further transmission is acted on by the node processor. In order to achieve flow-through operation, reception and transmission of a message must be occurring at the same time. Though no such system has been built, this could conceptually be done with only a slight delay for switching. A delay for switching is necessary because the node must have time to determine routings and to recognize the ends of messages. The delay needed could be

provided by a shift register as illustrated in Figure 5.1. Here it is assumed that the nodes send a continuous string of 0's over channels unless a message is to be sent. A message always starts with a 1 followed by the destination address. The end of the message is marked by a unique sequence of bits. As shown in Figure 5.1, the first positions of the shift register are used to read destination addresses and detect the ends of messages. The last portion of the shift register is used to introduce enough delay to allow the switch time to operate.

The second major application of the gradual input model is the identification of the effects of having a finite number of input channels to a network node. In Chapters 2 and 3 it was shown that there are several such effects. These effects will occur even if the network is operating in a store and forward fashion. Therefore, in designing a network, the gradual input model can be used to determine if there are any nodes at which there are significant effects due to a finite number of inputs.

The chapter on flow control in concentration tree structures addressed the problem of buffer allocation to achieve minimum probability of buffer overflow while using flow control. It was shown that in certain cases it is optimal to place all buffers at source nodes. However,

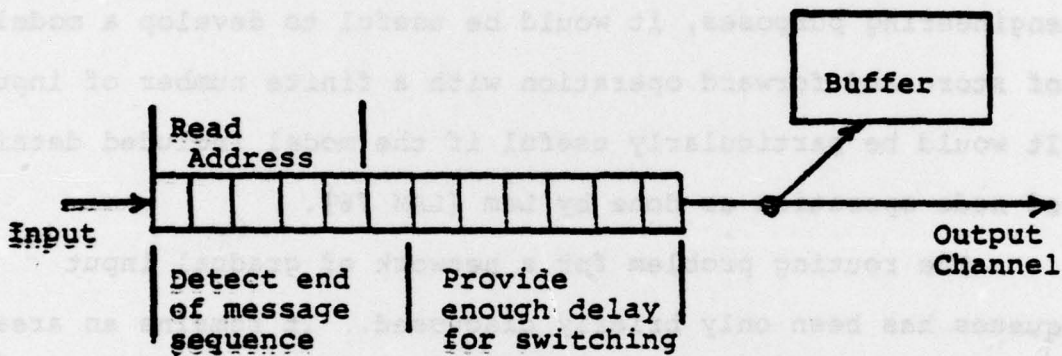

FIGURE 5.1 - Shift register used in a flow-through node

there are also cases where this is not so and an example was presented that gave insight into the reason for this.

5.2 Suggestions for Further Research

It has been shown that the effects of a finite number of input sources to a node can be important. Therefore, for engineering purposes, it would be useful to develop a model of store and forward operation with a finite number of inputs. It would be particularly useful if the model included details of node operation as done by Lam [LAM 76].

The routing problem for a network of gradual input queues has been only briefly discussed. It remains an area for future work.

Only one type of flow control has been studied in this work. Flow control in a concentration tree with a global controller is the only type considered. There is still much work to be done in the area of flow control for general networks.

Finally, it was shown that for certain concentration trees it is optimal to place all buffers at source nodes. An open question is whether there are any more general networks for which such a result is also true. Clearly, one such network is a star network in which the central node is used only for switching. This is a straightforward extension of a tree.

There may be others as well. Such networks would have no internal network buffers and therefore it may be possible to find myopic flow rules for the network that are optimal. This would be a step forward in the understanding of the optimal dynamic operation of a communication network.

APPENDIX A - RESULTS FOR THE GRADUAL INPUT QUEUE WITH NON-
IDENTICAL INPUT CHANNELS

Kaspi and Rubinovitch [KASPI 75] have derived results that allow one to analyze a gradual input queue with non-identical input channels. Each input channel is still described by an alternating renewal process as depicted in Figure 2.1b. The idle periods on the j th channel, τ_{ij} , are restricted to being exponentially distributed, i.e.

$$\Pr(\tau_{ij} \leq x) = 1 - e^{-\lambda_j x} \quad x > 0; \quad \lambda_j > 0$$

The active periods on the j th channel, σ_{ij} , are allowed to have a general distribution, i.e.

$$\Pr(\sigma_{ij} < x) = B_j(x) \quad x > 0$$

Previously, in the Cohen analysis, it was required that each $B_j(x) = B(x)$ and that all $\lambda_j = \lambda$. As before, the behavior of the buffer is analyzed by making an analogy with an M/G/1 queue. In order to make the desired analogy, one must again be able to obtain the distribution of the quantity $h-2$ for an inflow period and the distribution of the busy period on the output channel.

A. Distribution of h-l for an Inflow Period

For the jth input channel let

$$B_j = \int_{t=0}^{\infty} t dB_j(t)$$

$$B_j^*(\rho) = \int_{t=0}^{\infty} e^{-\rho t} dB_j(t)$$

Then the following relationship holds (Equation 3.3 in [KASPI 75]),

$$\{s + \lambda_T = \lambda_T E(\exp(-\rho h - s l))\}^{-1} =$$

$$\int_0^{\infty} e^{-st} \left\{ \prod_{j=1}^N \frac{1}{2\pi i} \int_{C_{u_j}} \frac{\exp(u_j t) du_j}{u_j + \lambda_j - \lambda_j B_j^*(\rho + u_j)} \right\} dt \quad (\text{Eq.A.1})$$

where $\lambda_T = \sum_{i=1}^N \lambda_i$, $\text{Re } s > 0$, $\text{Re } \rho \geq 0$, $\text{Re } u_j > 0$.

From Equation A.1, the first moments of h and l can be obtained. These are

$$E\{h\} = \left\{ \sum_{i=1}^N \lambda_i \beta_i \prod_{j \neq i} (1 + \lambda_j \beta_j) \right\} / \lambda_T \quad (\text{Eq.A.2})$$

$$E\{l\} = \left\{ \prod_{i=1}^N (1 + \lambda_i \beta_i) - 1 \right\} / \lambda_T \quad (\text{Eq.A.3})$$

The theorem due to Cohen which states that the maximum buffer content, C_{\max} , during a busy cycle for the gradual input queue is the same as the maximum virtual waiting time v_{\max} of an M/G/1 queue with a service time distribution identical

to that of $h-l$ and mean interarrival time λ_T^{-1} can now be applied. By using Equation 2.4, this yields the relationship

$$E\{C_{\max}\} = -\lambda_T^{-1} \log(1 - \lambda_T E\{h-l\}) \quad \lambda_T E\{h-l\} < 1$$

Together with Equations A.2 and A.3, this provides a closed form expression for $E\{C_{\max}\}$.

B. Distribution of the Busy Period on the Output Channel

For a gradual input queue with identical inputs, the distribution of the busy period on the output channel is the same as the busy period of an equivalent M/G/1 queue.

Specifically, Rubinovitch [RUBIN 73] showed that when $B_j(x) = B(x)$ and $\lambda_j = \lambda$ for all input channels j , the Laplace Stieltjes Transform (LST), $D^*(\rho)$, of the distribution of the length of the busy period, b , is given by the functional equation

$$D^*(\rho) = B^*((N-1)\lambda + \rho - (N-1)\lambda D^*(\rho)) \quad \text{Re } \rho > 0$$

For the case of non-identical inputs, let $D_j^*(\rho)$ be the LST of the distribution of the length of a busy period started by the j th input channel coming on. Then the following theorem gives the desired result for this case.

Theorem [KASPI 75]

- (i) The LST's $D_j^*(\rho)$, $1 \leq j \leq N$, are the unique solution to the system of functional equations

$$D_j^*(\rho) = B_j^*(\rho + \sum_{i \neq j} \lambda_i - \sum_{i \neq j} \lambda_i D_i^*(\rho)) \quad \text{Re } \rho > 0$$

(ii) $D^*(\rho)$ is given by

$$D^*(\rho) = \lambda_T^{-1} \sum_{i=1}^N \lambda_i B_i^*(\rho + \sum_{j \neq 1} \lambda_j - \sum_{j \neq 1} \lambda_j D_j^*(\rho))$$

(iii) Let $\alpha_i = \lambda_i \beta_i$ and $\Gamma = \sum_{i=1}^N \alpha_i / (1 + \alpha_i)$

then if $\Gamma < 1$

$$E\{b\} = \Gamma / \{\lambda_T (1 - \Gamma)\}$$

and if $\Gamma \geq 1$

$$E\{b\} = \infty$$

APPENDIX B - A LIMIT THEOREM FOR FIRST PASSAGE TIME
DISTRIBUTIONS†

First passage time distributions for queues which can be represented by a Markov chain are investigated in this appendix. It is shown that the tail behavior of such distributions is either geometric or exponential (depending on whether a discrete or continuous time example is being considered). This result provides insight into the dynamics of queue operation and can be used to approximate first passage time distributions.

A. A Preliminary Lemma

The proof of the main theorem in this appendix depends on the lemma that follows. The lemma applies to Markov chains with either a finite or countably infinite number of states. The state of the system at time t will be denoted by $x(t) = i$ ($i = 1, 2, 3, \dots$). State occupancy probabilities will be denoted by

$$p_i(t) = \Pr(x(t) = i) \quad t \geq 0$$

†This appendix is part of the paper: "A Note on the Chernoff Bound and a Limit Theorem for First Passage Time Distributions of Queues", by E.F. Wunderlich and P.A. Humblet, M.I.T. Electronic Systems Laboratory, ESL-P-728, March 1977.

Only homogeneous Markov chains are considered and state transition probabilities are given by

$$P_{ij}(t) = \Pr(x(t) = j \mid x(0) = i) \quad t > 0$$

For such a chain, the first passage time $T_f(i, j)$ is by definition

$$\inf\{T_f; x(T_f) = j \mid x(0) = i\}$$

The first passage time quantities that will be of interest are

$$F_{ij}(\leq t) = \Pr(T_f(i, j) \leq t)$$

$$F_{ij}(\leq t_2 \mid > t_1) = \Pr(T_f(i, j) \leq t_2 \mid T_f(i, j) > t_1)$$

$$0 \leq t_1 < t_2$$

Lemma: Consider an irreducible Markov chain. Modify the chain by making state k a trapping state, i.e. $P_{kk}(t) = 1$ for all $t \geq 0$. If for the modified chain

$$\lim_{t \rightarrow \infty} \frac{P_{ij}(t)}{1 - P_{ik}(t)} = c_j \quad 0 \leq c_j \leq 1 \text{ for all } j \neq k$$

then for both the original and the modified chain

$$\lim_{t_1 \rightarrow \infty} f_{ik}(\leq t_1 + \tau | > t_1) = \begin{matrix} 1 - b^\tau & \tau = 1, 2, 3, \dots \\ 1 - e^{-a\tau} & \tau > 0 \end{matrix}$$

$$1 > b > 0; a > 0$$

depending on whether the time index of the chain is discrete or continuous. The variables b and a may depend on the states i and k .

Proof: Consider the following two probabilities

$$f_{ik}(\leq t_1 + \tau | > t_1) \text{ and } f_{ik}(\leq t_1 + \tau + d | > t_1 + d) \text{ where } \tau > 0; d > 0.$$

The first passage time from state i to k in the original Markov chain is the same as the time until trapping in state k , starting from i , in the modified Markov chain. Therefore, the above can be written as

$$f_{ik}(\leq t_1 + \tau | > t_1) = \sum_{\substack{\text{all states } j \\ \text{except } j = k}} f_{ik}(\leq t_1 + \tau | x(t_1) = j) \Pr(x(t_1) = j | \text{first passage time} > t_1)$$

$$= \sum_{\substack{\text{all states } j \\ \text{except } j = k}} f_{jk}(\leq \tau) \Pr(x(t_1) = j | \text{first passage time} > t_1)$$

$$= \sum_{\substack{\text{all states } j \\ \text{except } j = k}} f_{jk}^{(\leq \tau)} \frac{P_{ij}(t_1)}{1 - P_{ik}(t_1)}$$

where $p_{ij}(t_1)$ and $p_{ik}(t_1)$ refer to the modified chain.

Similarly

$$f_{ik}^{(\leq (t_1+d)+\tau | > t_1+d)} = \sum_{\substack{\text{all states } j \\ \text{except } j = k}} f_{jk}^{(\leq \tau)} \frac{P_{ij}(t_1+d)}{1 - P_{ik}(t_1+d)}$$

Now recall that $\lim_{t_1 \rightarrow \infty} \frac{P_{ij}(t_1)}{1 - P_{ik}(t_1)} = c_j$ and note also that

$\lim_{t_1 \rightarrow \infty} \frac{P_{ij}(t_1+d)}{1 - P_{ik}(t_1+d)} = c_j$. Therefore as $t_1 \rightarrow \infty$ it follows that

$\frac{P_{ij}(t_1)}{1 - P_{ik}(t_1)} \rightarrow \frac{P_{ij}(t_1+d)}{1 - P_{ik}(t_1+d)}$ since both terms converge to c_j . This

leads to the result that as $t_1 \rightarrow \infty$

$$f_{ik}^{(\leq t_1+\tau | > t_1)} \rightarrow f_{ik}^{(\leq (t_1+d)+\tau | > t_1+d)} \quad (\text{Eq.B.1})$$

Therefore, in the limit as $t_1 \rightarrow \infty$, Equation B.1 can be written in the form

$$\Pr(0 < T_r \leq \tau) = \Pr(T_r \leq \tau + d | > d) \quad (\text{Eq.B.2})$$

where T_r = remaining time (after time t_1) until first passage from state i to state k conditioned on the fact

that the first passage time from state i to state k is greater than t_1 . It is well known that Equation B.2 implies that the distribution of T_r is either geometric or exponential. [PARC 62].

An intuitive interpretation of this lemma is that if the distribution of state occupancy probabilities in the modified chain, conditioned on the fact that the trapping state has not been entered, has a steady state, then the remaining time until trapping (remaining first passage time) is either geometric or exponential. The following theorem proves that this conditional steady state distribution exists and shows how it can be found for a discrete time, finite state Markov chain.

B. Main Result

Theorem: Consider a discrete time, finite state Markov chain. Modify the chain by making state k a trapping state, i.e., $p_{kk}(t) = 1$ for all $t(t=0,1,2,3\dots)$. If in the modified system, all states (except k) that are accessible from state i communicate with i and are not periodic and if state k is accessible from state i , then for the modified system

$$\lim_{t \rightarrow \infty} \frac{\tilde{p}_{ij}(t)}{1 - \tilde{p}_{ik}(t)} = c_j \quad 0 \leq c_j \leq 1 \text{ for all } j \neq k$$

$$\text{and } \lim_{t \rightarrow \infty} f_{ik}(\leq t + \tau | > t) = 1 - b^\tau$$

$$\tau = 1, 2, 3, 4, \dots ; 1 > b > 0$$

Proof: The evolution of state occupancy probabilities for the original Markov chain is given by

$$\pi(t+1) = \pi(t)P \quad t = 0,1,2,3,\dots$$

where π is a row vector of state occupancy probabilities and P is the matrix of one step transition probabilities. [PRAZ 62] Similarly, the state occupancy probabilities for the modified Markov chain are given by

$$\tilde{\pi}(t+1) = \tilde{\pi}(t) \tilde{P} \quad t = 0,1,2,3,\dots \quad (\text{Eq.B.3})$$

where \tilde{P} is nearly identical to P . \tilde{P} and P differ only in the k th row. In the k th row of \tilde{P} , \tilde{p}_{kk} is 1 and all other entries are 0. The initial condition for the modified chain is $\tilde{\pi}_i(0) = 1$ and $\tilde{\pi}_j(0) = 0$ for all $j \neq i$. Since the first passage time from state i to k in the original Markov chain is the same as the time until trapping in the modified chain, only the latter will be considered. From Equation B.3, one can express $\tilde{\pi}_j(t+1)$ as

$$\tilde{\pi}_j(t+1) = \sum_{\text{all states } l} \tilde{\pi}_l(t) \tilde{p}_{lj} = \sum_{\substack{\text{all states} \\ \text{except } l=k}} \tilde{\pi}_l(t) \tilde{p}_{lj} \quad (j \neq k) \quad (\text{Eq.B.4})$$

$$\tilde{\pi}_k(t+1) = \tilde{\pi}_k(t) + \sum_{\substack{\text{all states} \\ \text{except } l=k}} \tilde{\pi}_l(t) \tilde{p}_{lk} \quad (\text{Eq.B.5})$$

Note that $\tilde{\pi}_j(t+1)$ ($j \neq k$) satisfies a recursion equation that does not contain $\tilde{\pi}_k(t)$. Also note that $\tilde{\pi}_j(t)$ ($j \neq k$) will be 0 for all t for any state that does not communicate with state i when one removes the trapping state k from the modified chain. Therefore one can write

$$\tilde{\pi}(t+1) = \tilde{\pi}(t) \tilde{P} \quad (\text{Eq.B.6})$$

where $\tilde{\pi}$ is a row vector of state occupancy probabilities that does not include the trapping state or any state which does not communicate with state i after the trapping state is deleted and \tilde{P} is the matrix P having the rows and columns associated with the deleted states removed. The elements of \tilde{P} are all non-negative; i.e. $\tilde{P}_{lj} \geq 0$. Therefore $\tilde{P} > 0$. Furthermore, since all states considered in P communicate with state i and are not periodic, $\tilde{P}^m \gg 0$ for some integer $m > 0$, where \gg signifies that all elements of \tilde{P}^m are > 0 .

The following Frobenius Theorems for positive matrices [KARL 75] can therefore be applied.

- T1: If matrix $A > 0$ and $A^m \gg 0$, for some integer $m > 0$, then (a) there exists a vector $x^0 \gg 0$ such that $x^0 A = \alpha_0 x^0$;
 (b) if $\alpha \neq \alpha_0$ is any other eigenvalue of A , then $|\alpha| < \alpha_0$;
 (c) the left eigenvectors of A with eigenvalue α_0 form a one dimensional subspace.

T2: If $A > 0$ and $A^m >> 0$ for some integer $m > 0$, then

$$\frac{1}{\alpha_0^n} A^n \rightarrow B \text{ as } n \rightarrow \infty$$

where $B >> 0$ is a matrix of rank 1 with elements $b_{ij} = f_i^0 x_j^0$ where x^0 is the row vector given above and f^0 is a column vector satisfying $Af^0 = \alpha_0 f^0$ which is normalized by a multiplicative factor so that $\sum_i x_i^0 f_i^0 = 1$.

T3: If $A > 0$, then the eigenvalue of largest magnitude $\alpha_0 = \alpha_0(A)$, is real and non-negative and if there exists a vector $x^0 >> 0$ such that $x^0 A \leq ux^0$, then u is an upper bound for $\alpha_0(A)$.

T1 states that there is a largest eigenvalue of P and that the left eigenvector associated with it is unique (to within a constant).

Let r be the largest eigenvalue of P . Then, because $\tilde{\pi}(t) = \tilde{\pi}(0)P^t$

$$\lim_{t \rightarrow \infty} \frac{\tilde{\pi}(t)}{r^t} = \lim_{t \rightarrow \infty} \tilde{\pi}(0) \frac{P^t}{r^t} = \tilde{\pi}(0) B \quad (\text{Eq. B.7})$$

by applying T2. This implies that

$$\lim_{t \rightarrow \infty} \frac{\tilde{\pi}_j(t)}{\sum_{\text{all states } j} \tilde{\pi}_j(t)} = c_j \quad 0 \leq c_j \leq 1 \text{ for all } j \neq k \quad (\text{Eq. B.8})$$

from which it follows that the previous lemma holds. Equation B.8 is equivalent to

$$\lim_{t \rightarrow \infty} \frac{\bar{P}_{ij}(t)}{1 - \bar{P}_{ik}(t)} = c_j \quad 0 \leq c_j \leq 1 \text{ for all } j=k$$

By noting that the vector c of components $\{c_j\}$ is a scaled version of $\bar{\pi}(0)B = \bar{\pi}(0)f^0 x^0$ it can be shown that c is the left eigenvector (scaled to have $\sum_j c_j = 1$) of \bar{P} that is associated with the eigenvalue r . T3 can be used to show that r is real and nonnegative. Since all states in $\bar{\pi}$ are transient, the sum of elements in at least one row of \bar{P} is less than 1 and therefore it can be shown that $r < 1$.

It will now be shown that the constant b in the statement of the theorem equals r . Recall that $f_{ik}(\leq t+\tau | > t) = \bar{\pi}_k(t+\tau)$ if $\bar{\pi}_k(t) = 0$. If $\bar{\pi}_k(t) = 0$, then $\lim_{t \rightarrow \infty} \bar{\pi}_j(t) = c_j$; $j \neq k$. Since the states $\bar{\pi}_j$ ($j \neq k$) are the same as those in the $\bar{\pi}_j$ system, one can apply the equation

$$\bar{\pi}(t+1) = \bar{\pi}(t) \bar{P}$$

Noting again that the vector c is the left eigenvector of \bar{P} associated with the eigenvalue r , it follows that if

$$\bar{\pi}_j(t) = c_j$$

$$\text{then } \bar{\pi}_j(t+\tau) = r^\tau c_j \quad \tau = 1, 2, 3, \dots$$

$$j \neq k$$

$$\text{Since } \bar{\pi}_k(t+\tau) = 1 - \sum_{j \neq k} \bar{\pi}_j(t+\tau),$$

$$\text{if } \bar{\pi}_k(t) = 0 \text{ and as } t \rightarrow \infty$$

$$\bar{\pi}_k(t+\tau) = 1 - r^\tau = f_{ik}(t+\tau | > t)$$

$$\tau = 1, 2, 3, \dots$$

Therefore $r = b$.

C. Extension to Continuous Time Markov Chains

The previous theorem applies only to discrete time Markov chains. A similar theorem can be proven for continuous time Markov chains by applying the Kolmogorov differential equations for such chains. The Kolmogorov equations for homogeneous chains are

$$\frac{d}{dt} P(t) = P(t)\bar{A} \quad \text{and} \quad \frac{d}{dt} \bar{P}(t) = \bar{A} \bar{P}(t)$$

where the states associated with $\bar{P}(t)$ are defined as in the previous theorem and \bar{A} is a matrix of transition intensities. [PARZ 62] The initial condition is $\bar{P}(0) = I$ and the solution to the equations is $\bar{P}(t) = e^{\bar{A}t}$. In order to prove the desired theorem, one proceeds basically as follows. Let a be the

largest eigenvalue of \bar{A} . It can be shown that $\alpha < 0$ and that α is an eigenvalue of multiplicity 1. Now \bar{A} can be expressed in Jordan normal form as follows.

$$\text{Let } J = Q^{-1} \bar{A} Q = \begin{bmatrix} J_1 & & \\ & J_2 & \\ & & \ddots \end{bmatrix} = \begin{bmatrix} \alpha & & \\ & J_2 & \\ & & \ddots \end{bmatrix}$$

where each J_i is a Jordan block [NEF 67]. Then

$$e^{\bar{A}t} = Q e^{Jt} Q^{-1} = Q \begin{bmatrix} e^{\alpha t} & & \\ & e^{J_2 t} & \\ & & \ddots \end{bmatrix} Q^{-1}$$

Since α is the largest eigenvalue and $\alpha < 0$, as $t \rightarrow \infty$, the terms $e^{J_2 t}$, $e^{J_3 t}$, ... etc. go to zero faster than $e^{\alpha t}$.

Therefore as

$$t \rightarrow \infty \quad \frac{e^{\bar{A}t}}{e^{\alpha t}} \rightarrow Q \begin{bmatrix} 1 & & \\ & 0 & \\ & & 0 \\ & & & \ddots \\ & & & & 0 \end{bmatrix} Q^{-1}$$

From this it follows that

$$\lim_{t \rightarrow \infty} \frac{\bar{P}_{ij}(t)}{\sum_j \bar{P}_{ij}(t)} = \frac{\bar{\pi}_j(t)}{\sum_j \bar{\pi}_j(t)} = d_j \quad 0 \leq d_j \leq 1 \text{ for all } j$$

Therefore

$$\lim_{t \rightarrow \infty} f_{ik}(\leq t + \tau | > t) = 1 - e^{\alpha \tau}$$

$$\alpha < 0; \tau > 0$$

by the lemma given at the beginning of this section.

D. Approximation Techniques for Markov Chains

First passage time distributions in Markov chains are often quite complicated. The previous theorem, however, shows that their tail behavior can be described by a simple one parameter geometric or exponential distribution. This result can be used to approximate the behavior of a queue that has a Markov chain representation consisting of many states by a chain which has only a few states. For example, consider the discrete time Markov chain representation of a single server queue shown in Figure B.1. The states of the chain are the number of customers in the system. Suppose that one is interested only in whether or not the server is idle, i.e. whether or not the system is in state 0. Since detailed information is desired only about state 0, an approximation of the original N stage chain by a smaller chain (like the three state chain shown in Figure B.2) might be useful. The approximating chain shown in Figure B.2 is an attempt to use only two stages to produce a first passage time distribution similar to the distribution due to N-1

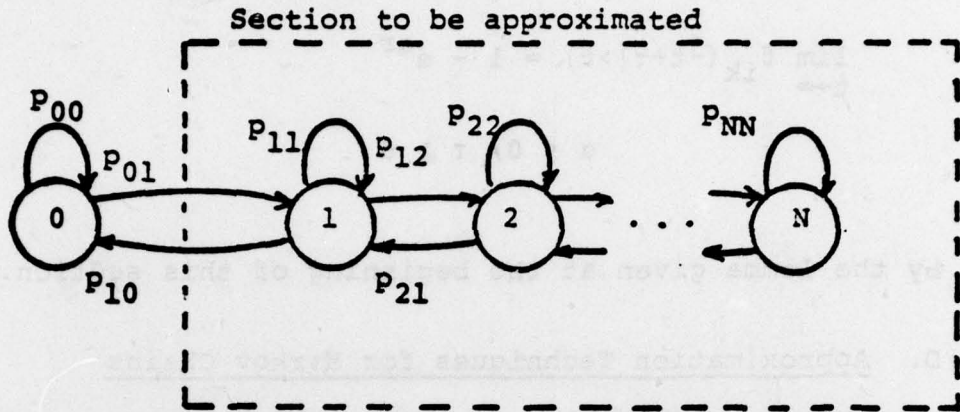

FIGURE B.1 - Markov chain representation of a single server queue. For this chain

$$\lim_{t \rightarrow \infty} f_{10}(\leq t + \tau | > t) = 1 - r^{\tau} \quad \tau = 1, 2, 3, \dots$$

$$0 < r < 1$$

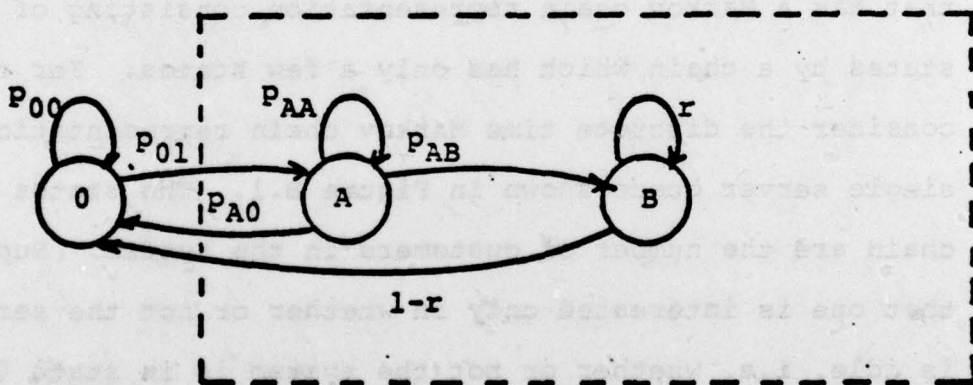

FIGURE B.2 - Approximating chain for chain in Figure B.1.

If $p_{AA} < r$, then state B gives the proper tail behavior for the first passage time distribution from state 1 to state 0. Parameters p_{AA} , p_{AB} and p_{A0} are then free to be adjusted (for example to try to equate the mean time to go from state A to 0 to the mean time to go from state 1 to 0).

states in the original chain. The approximation is done by equating the tail behavior of the two distributions. The parameters P_{AA} , P_{AB} and P_{AO} might then be chosen to try to match another characteristic of the approximating distribution (such as the mean) to that of the actual distribution. Approximations such as this are particularly useful when considering networks of queues whose total state space is too large to handle by exact analytic techniques, but whose component queues can each be approximated and then be analyzed as one system. The development of a theory for such approximations is an area open for further investigation.

A final observation is that while the theorem in this appendix has been formulated for a single first passage time, it can be generalized to consider several first passage problems simultaneously. For example, in a queueing system, one may be interested in first passage times conditioned on events such as a busy period ending before a buffer overflow occurs. The tail distributions of such first passage times can also be shown to be geometric or exponential.

REFERENCES

- [BORG 73] Borgonovo, F. and Fratta, L., "A Model for Finite Storage Message Switching Networks," Fifth Conf. on Optimization Techniques Part II, Springer Verlag, Berlin, 1973, pp 97-109.
- [BURKE 56] Burke, P.J., "The Output of a Queueing System," Operations Research, Vol. 4, 1956, pp 699-704.
- [CANT 74] Cantor, D. and Gerla, M., "Optimal Routing in a Packet Switched Computer Network," IEEE Trans. on Computers, Vol. C-23, No. 10, Oct 1974.
- [CHOU 75] Chou, W. and Gerla, M., "A Unified Flow Control Strategy for Computer Communications," Fourth Data Communications Symposium, IEEE, Oct 1975, p 9-4.
- [CHU 69] Chu, W.W., "Design Considerations of Statistical Multiplexors," ACM Symposium on Problems in the Optimization of Data Communications Systems, Pine Mountain, Georgia, Oct. 13-16, 1969, pp 35-59.
- [CHU 70A] Chu, W.W., "Buffer Behavior for Batch Poisson Arrivals and Single Constant Output," IEEE Trans. on Comm., Vol. 18, No. 5, Oct 1970, p 613.
- [CHU 70B] Chu, W.W., "Selection of Optimal Transmission Rate for Statistical Multiplexors," 1970 IEEE Int. Conf. on Communications, San Francisco, June 8-10, pp 28-22 to 28-25.
- [CHU 73] Chu, W.W., "Asynchronous Time-Division Multiplexing Systems," in Computer-Communication Networks, Abramson, N. and Kuo, F. eds., Prentice-Hall, Englewood Cliffs, N.J., 1973.

- [COHEN 69] Cohen, J.W., The Single Server Queue, North-Holland Pub. Co., Amsterdam, 1969.
- [COHEN 74] Cohen, J.W., "Superimposed Renewal Processes and Storage with Gradual Input," Stochastic Processes and their Applications, Vol. 2, 1974, pp 31-58.
- [DANET 76] Danet, A., Despres, A., LeRest, G., Pichon, G. and Ritzenhalen, S., "The French Public Packet Switching Service: The Transpac Network," Int. Conf. on Computer Comm., Toronto, Aug. 3-6, 1976, Int. Council for Computer Communication, Washington, D.C.
- [DAV 72] Davies, D.W., "The Control of Congestion in Packet-Switching Networks," IEEE Trans. on Communications, Vol. 20, No. 3, Part II, June 1972, pp 546-550.
- [DESOER 75] Desoer, C.A. and Vidyasager, M., Feedback Systems: Input-Output Properties, Academic Press, N.Y., 1975.
- [DRAKE 67] Drake, A.W., Fundamentals of Applied Probability Theory, McGraw-Hill, N.Y., 1967.
- [GERLA 74] Gerla, M. and Chou, W., "Flow Control Strategies in Packet Switched Computer Networks," 1974 National Telecommunications Conf., IEEE, San Diego, Calif., Dec 1974, pp 1032-1037.
- [GORD 70] Gordon, T.H., Meltzer, J., and Pilc, R., "Design and Performance of a Statistical Multiplexor," 1970 IEEE Int. Conf. on Communications, San Francisco, June 8-10, pp 28-9 to 28-21.
- [HOWD 64] Howard, R.A., "System Analysis of Semi-Markov Processes," IEEE Trans. on Military Electronics, April 1964, pp 114-124.

- [HOWD 71] Howard, R.A., Dynamic Probabilistic Systems, Vol. 1 & 2, Wiley & Sons, N.Y., 1971.
- [HSU 73] Hsu, J., "A General Queueing Model for Buffer Storage Problems," IEEE Trans. on Communications, Vol. 21, No. 6, June 1973, p 744.
- [HSU 74] Hsu, J., "Buffer Behavior with Poisson Arrival and Geometric Output Processes," IEEE Trans. on Communications, Vol. 22, No. 12, Dec 1974, p. 1940.
- [IRLND 75] Irland, M., "Queueing Analysis of a Buffer Allocation Scheme for a Packet Switch," 1975 National Telecommunications Conference, IEEE, New Orleans, Dec. 1-3, pp 24-8 to 24-13.
- [JACK 57] Jackson, J., "Networks of Waiting Lines," Operations Research, Vol. 5, 1957, pp 518-521.
- [KAHN 72A] Kahn, R.E., "Resource Sharing Computer Communications Networks," Proceedings of the IEEE, Vol. 60, No. 11, Nov 1972, pp 1397-1407.
- [KAHN 72B] Kahn, R.E. and Crowther, W.R., "Flow Control in a Resource-Sharing Network," IEEE Trans. on Communications, Vol. 20, No. 3, Part II, June 1972, pp 539-546.
- [KARL 75] Karlin, S. and Taylor, H.M., A First Course in Stochastic Processes, Academic Press, N.Y., 1975.
- [KASPI 75] Kaspi, H. and Rubinovitch, M., "The Stochastic Behavior of a Buffer with Non-Identical Input Lines," Stochastic Processes and their Applications, Vol. 3, 1975, pp 73-88.
- [KING 70] Kingman, J.F.C., "Inequalities in the Theory of Queues," Royal Stat. Soc. J., Vol. 32, 1970, pp 102-110.

- [KLEIN 64] Kleinrock, L., Communication Nets: Stochastic Message Flow and Delay, McGraw-Hill, New York, 1964.
- [KLEIN 75] Kleinrock, L., Queueing Systems Volume 1: Theory, John Wiley & Sons, New York, 1975.
- [KOB 77] Kobayashi, H. and Konheim, A.G., "Queueing Models for Computer Communication System Analysis," IEEE Trans. on Communications, Vol. 25, No. 1, Jan 1977, pp 2-29.
- [LAM 76] Lam, S.S., "Store and Forward Buffer Requirements in a Packet Switching Network," IEEE Trans. on Communications, Vol. 24, No. 4, April 1976, pp 394-403.
- [LITTLE 61] Little, J.D.C., "A Proof of the Queueing Formula $L=\lambda W$ ", Operations Research, Vol. 9, No. 3, May-June 1961, pp 383-387.
- [METCF 73] Metcalfe, R.M., "Packet Communication," Report MAC TR-114, Project MAC, Mass. Inst. of Tech., Cambridge, Ma., July 1973.
- [NEF 67] Nef, W., Linear Algebra, McGraw-Hill, N.Y., 1967.
- [PACK 74] Pack, C.D., "The Optimum Design of a Tandem Computer Buffer in a System for Remote Data Collection," IEEE Trans. on Communication, Vol. 22, No. 10, Oct 1974, p 1501.
- [PARZ 62] Parzen, E., Stochastic Processes, Holden-Day, San Francisco, 1962.
- [PENN 74] Pennotti, M.C. and Schwartz, M., "The Control of Congestion in Message Switched Networks," 1974 IEEE Int. Conf. on Comm., Minneapolis, Minn.

- [POUZ 74] Pouzin, L., "Presentation and Major Design Aspects of the Cyclades Computer Network," Proc. 3rd Data Communications Symposium, IEEE, 1974, p 80.
- [RICCI 75] Ricci, F.J., "The State of the Art and Control of Packet Switches and Networks," 1975 IEEE Int. Conf. on Comm., San Francisco, June 1975, pp 6-1 to 6-3.
- [RICH 75] Rich, M. and Schwartz, M., "Buffer Sharing in a Computer-Communication Network Node," 1975 IEEE Int. Conf. on Comm., San Francisco, June 16-18, pp 33-17 to 33-21.
- [RBRTS 70] Roberts, L.G. and Wessler, B.D., "Computer Network Development to Achieve Resource Sharing," Spring Joint Computer Conf., AFIPS Conf. Proc., Vol. 36, 1970, pp 543-549.
- [ROSN 73] Rosner, R.D., "A Digital Data Network Concept for the Defense Communications System," Proc. of the National Telecommunications Conf., IEEE, Atlanta, Nov 1973, pp 22c1-C6.
- [RUBIN 75] Rubin, I., "Message Path Delays in Packet-Switching Communication Networks," IEEE Trans. on Communications, Vol. 23, Feb 1975, pp 186-192.
- [RUBIN 73] Rubinovitch, M., "The Output of a Buffered Data Communications System," Stochastic Processes and their Applications, Vol. 1, 1973, pp 375-382.
- [RUDIN 70] Rudin, H., "Performance of a Simple Multiplexor for Data Communication," 1970 IEEE Int. Conf. on Comm., San Francisco, June 8-10, pp 35-32 to 35-38.
- [SEN 74] Sencer, M.A., "Evaluation of Packet Switching Network Controlled on Isarithmic Principles," 1974 National Telecommunications Conf., IEEE, San Diego, Calif., Dec 1974, pp 838-842.

- [TAKACS 65] Takacs, L., "Applications of Ballot Theorems in the Theory of Queues," Proc. Symp. on Congestion Theory, eds. Smith and Wilkinson, U. of N.C., Chapel Hill, N.C., 1965.
- [TAKACS 76] Takacs, L., "On the Busy Periods of Single Server Queues with Poisson Input and General Service Times," Operations Research, Vol. 24, No. 3, May-June 1976, pp. 564-571.
- [WYNER 74] Wyner, A.D., "On the Probability of Buffer Overflow Under an Arbitrary Bounded Input-Output Distribution," SIAM J. Appl. Math., Vol. 27, Dec 1974, pp 544-570.
- [YEE 76] Yee, J.R., "Minimax Routing in a Computer Communications Network," Sc.D. Thesis Proposal, M.I.T., Department of EECS, Nov. 19, 1976.

Distribution List

Defense Documentation Center Cameron Station Alexandria, Virginia 22314	12 copies
Assistant Chief for Technology Office of Naval Research, Code 200 Arlington, Virginia 22217	1 copy
Office of Naval Research Information Systems Program Code 437 Arlington, Virginia 22217	2 copies
Office of Naval Research Code 1021P Arlington, Virginia 22217	6 copies
Office of Naval Research Branch Office, Boston 495 Summer Street Boston, Massachusetts 02210	1 copy
Office of Naval Research Branch Office, Chicago 536 South Clark Street Chicago, Illinois 60605	1 copy
Office of Naval Research Branch Office, Pasadena 1030 East Green Street Pasadena, California 91106	1 copy
New York Area Office (ONR) 715 Broadway - 5th Floor New York, New York 10003	1 copy
Naval Research Laboratory Technical Information Division, Code 2627 Washington, D.C. 20375	6 copies

Dr. A. L. Slafkosky
Scientific Advisor
Commandant of the Marine Corps (Code RD-1)
Washington, D.C. 20380

1 copy

Office of Naval Research
Code 455
Arlington, Virginia 22217

1 copy

Office of Naval Research
Code 458
Arlington, Virginia 22217

1 copy

Naval Electronics Laboratory Center
Advanced Software Technology Division
Code 5200
San Diego, California 92152

1 copy

Mr. E. H. Gleissner
Naval Ship Research & Development Center
Computation and Mathematics Department
Bethesda, Maryland 20084

1 copy

Captain Grace M. Hopper
NAICOM/MIS Planning Branch (OP-916D)
Office of Chief of Naval Operations
Washington, D.C. 20350

1 copy

Mr. Kin B. Thompson
Technical Director
Information Systems Division (OP-91T)
Office of Chief of Naval Operations
Washington, D.C. 20350

1 copy

Advanced Research Projects Agency
Information Processing Techniques
1400 Wilson Boulevard
Arlington, Virginia 22209

1 copy