

AD-A051 241

COLORADO UNIV BOULDER DEPT OF CIVIL ENVIRONMENTAL AN--ETC F/6 11/2
USE OF EPOXY IN TENSION LAP SPLICES -- IMPACT ON DEVELOPMENT LE--ETC(U)
1977 W E BENEDICT

UNCLASSIFIED

NL

1 OF 2
AD A051 241

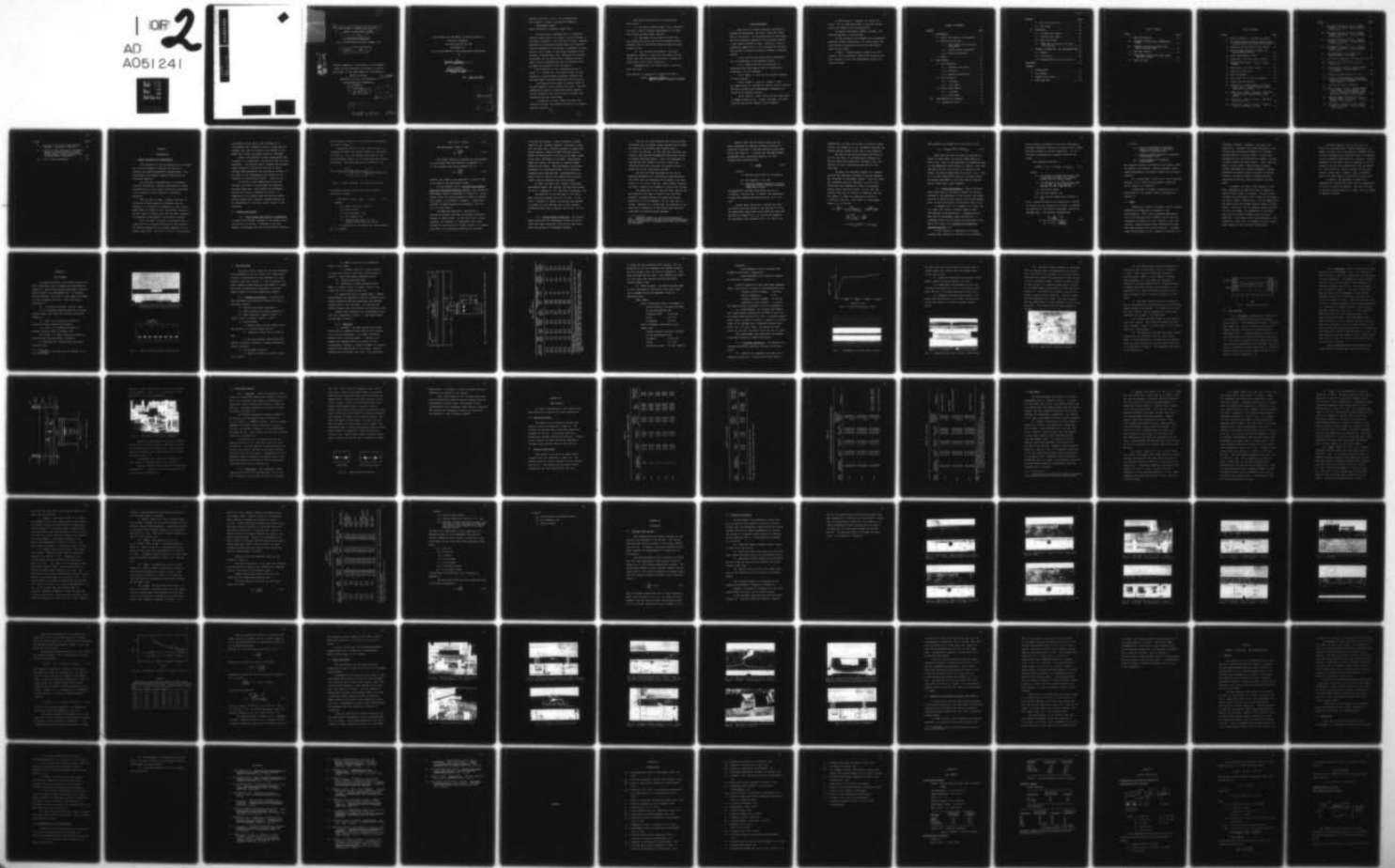



AD A051241

AD No. _____
DDC FILE COPY

①

[Redacted]

DDC
RECORDED
MAR 16 1978
[Signature]

1

6 USE OF EPOXY IN TENSION LAP SPLICES--
IMPACT ON DEVELOPMENT LENGTH.

by

10 William E./Benedict

B.S., United States Military Academy, 1971

9 Master's thesis

AD NO. _____
DDC FILE COPY

A thesis submitted to the Faculty of the Graduate
School of the University of Colorado in partial
fulfillment of the requirements for the degree of

Master of Science

Department of Civil, Environmental,

New
410 602

and Architectural Engineering

11 1977

12 114 p.

DDC
RECORDED
MAR 16 1978
REGULATED

AT A

DISTRIBUTION STATEMENT A
Approved for public release;
Distribution Unlimited

410 602 Gu

This Thesis for the Master of Science Degree by
William E. Benedict
has been approved for the
Department of
Civil, Environmental, and Architectural Engineering
by

James Chinn
James Chinn

Robert I. Carr
Robert I. Carr

Date May 4, 1977

RECEIVED BY	
YES	DATE SIGNED <input checked="" type="checkbox"/>
NO	DATE SIGNED <input type="checkbox"/>
REPRODUCTION	<input type="checkbox"/>
<i>Letter on file</i>	
BY	
DISTRIBUTION AVAILABILITY CODE	
ONE	MAIL OR BY SPECIAL
A	

Benedict, William E. (M.S., Civil Engineering)
Use of Epoxy in Tension Lap Splices--Impact on
Development Length

Thesis directed by Professor James Chinn

The splicing of deformed bars in reinforced concrete construction is an area of active interest to structural engineers. Over the past 25 years, research conducted on reinforced concrete beams has indicated that the strength of a lap splice is dependent on many factors, one of which is the tensile strength of the concrete. Theoretically then, replacing the concrete surrounding the lap splice with a material having a higher tensile strength than that of concrete would increase the strength of the lap splice.

→ The objective of this investigation was to study, in a limited way, the relative merit of this hypothesis, using an epoxy concrete to replace the portland cement concrete surrounding the lap splice.

Six series of test beams of varying length of lap and companion test cylinders were cast. Concrete compressive strength, concrete and epoxy concrete tensile strengths, and relative beam strengths were determined for each test series.

A comparison of test results was made with predicted critical lap lengths according to a recently proposed equation.



III

The results obtained led to the following conclusions:

(1) The epoxy concrete used in this investigation had a tensile strength approximately 2.8 times that of the portland cement concrete.

(2) The beams with an epoxy concrete block cast around the lap splices had considerably greater strength than the reinforced concrete beams for equal lengths of lap.

(3) This limited investigation indicated substantial savings in steel with the epoxy concrete splice zone with corresponding savings in design and construction time a real possibility.

Recommendations for future study in this area were also made.

This abstract is approved as to form and content.

Signed

James Chinn
Faculty member in charge of thesis

ACKNOWLEDGEMENTS

When trying to express deep-felt gratitude to friends and associates, the words "thank you" never seem to say enough. In the preparation of this thesis and the successful completion of my graduate studies, I have become indebted to many. Publicly, I wish to express my appreciation to the following for the part they played in helping me attain my Master of Science Degree:

To the United States Army Corps of Engineers for its sponsorship of my graduate studies.

To Dr. James Chinn for his suggestion to undertake this investigation and his assistance in preparation of this treatise.

To Dr. Robert I. Carr for his critical reading of this treatise.

To Dr. Robert S. Ayre, Dr. Robert I. Carr, Dr. James Chinn, Dr. Hon-Yim Ko, and Dr. Kurt H. Gerstle for their guidance and encouragement throughout the course of my graduate studies.

To Mr. Myles A. (Tony) Murray and his associates at PROTEX Industries Inc., Denver, Colorado, for their technical advice and support of this research.

To CPT William F. Vanaskie, my "cohort-in-crime," for his long hours spent in the lab with me during the course of this investigation.

To Stanley Structures, Denver, Colorado, for donating material to this project.

To the University of Colorado Civil Engineering Laboratory Staff, particularly Mr. David Jones, for their technical assistance during the experimental phase of this study.

Finally, I extend special thanks to my wife, Barbara, and our daughters, Rebecca and Kathleen, for their patience, love, and understanding during this time and always.

TABLE OF CONTENTS

CHAPTER	PAGE
I. INTRODUCTION	1
1.1 Object and Scope of Investigation .	1
1.2 Tension Lap Splices	2
1.2.1 Basic Theory and Historical Background	2
1.2.2 Current Design Provisions .	5
1.2.3 Recent Developments	9
1.3 Epoxy	11
II. TEST PROGRAM	14
2.1 Test Specimens	16
2.1.1 Geometry and Details	16
2.1.2 Materials	17
2.1.3 Specimen Fabrication	21
2.2 Test Procedure	26
2.2.1 Cylinders	26
2.2.2 Test Beams	27
2.3 Anticipated Results	30
2.3.1 Cylinders	30
2.3.2 Test Beams	30
III. TEST RESULTS AND ANALYSIS	33
3.1 Compression Tests	33

CHAPTER	PAGE
3.2 Split-Cylinder Test	33
3.3 Test Beams	38
IV. DISCUSSION	48
4.1 Cylinder Test Results	48
4.2 Concrete Test Beams	49
4.3 Epoxy Test Beams	59
4.4 Comparison of Concrete and Epoxy Test Results	65
V. SUMMARY, CONSLUSIONS, AND RECOMMENDATIONS	68
5.1 Summary	68
5.2 Conclusions	69
5.3 Recommendations for Future Study .	70
REFERENCES	72
APPENDIX	
A. NOMENCLATURE	76
B. MIX DESIGNS	79
C. SAMPLE CALCULATIONS	81
D. BEAM TEST DATA	86

LIST OF TABLES

TABLE	PAGE
I. TEST BEAM DETAILS	19
II. CONCRETE CYLINDER DATA--COMPRESSION TESTS	34
III. CONCRETE AND EPOXY CYLINDER DATA-- SPLIT-CYLINDER TESTS	36
IV. TEST BEAM RESULTS	45
V. COMPARISON OF CALCULATED BOND STRESS AND TEST VALUES	57
VI. BEAM TEST DATA	87

LIST OF FIGURES

FIGURE	PAGE
1. Stress Transfer in a Tension Lap Splice .	3
2. Test Beam (Tension Side Up) Showing Epoxy Concrete Block Cast Around Lap Splices	15
3. Repeating Section Used for Beam Design .	15
4. Nominal Beam Dimensions (Inches) and Reinforcement Location	18
5. Steel Stress-Strain Curve	22
6. Photograph of #6 Bars Used in Tests . . .	22
7. Temporary End Forms in Place in Epoxy Beams	23
8. Power Drill and Mixing Stirrer	24
9. Specimen Curing Cycle	26
10. Test Arrangement	28
11. Test Beam T-1-C in Test Arrangement . . .	29
12. Common Failure Patterns	31
13. Beam T-4-C. Splice Length = 12 inches. Load = 3kpj. Flexure Cracks Develop Near Ends of Splices	51
14. Beam T-4-C. Load = 5.25 kpj. Horizontal Cracking Along Reinforcement Plane Begins	51
15. Beam T-4-C. Load = 5.5 kpj. Side Split Failure Occurs	52
16. Beam T-4-C. Load = 5.5 kpj. Close Up View of Side Split Failure	52

FIGURE	PAGE
17. Side Split Failure of T-1-C. Splice Length = 12 inches. Failure Moment = 12.75 kip-ft	53
18. Side Split Failure of T-3-C. Splice Length = 16 inches. Failure Moment = 13.0 kip-ft	53
19. Side Split Failure of T-4-C. Splice Length = 12 inches. Failure Moment = 11.0 kip-ft	54
20. Side Split Failure of T-5-C. Splice Length = 14 inches. Failure Moment = 11.5 kip-ft	54
21. Face Splitting in Test Beam T-3-C. Splice Length = 16 inches	55
22. Side View of Side Split Failure of T-3-C	55
23. Variation of $u/\sqrt{f'_c}$ with l_s/d_b for $C/d_b = 2/3$	57
24. Bond Failure of T-1-E. Splice Length = 12 inches. Failure Moment = 22.3 kip-ft	60
25. Close Up of Bond Failure of T-1-E	60
26. Failure in Test Specimen T-2-E After Yielding of the Tensile Reinforcement Splice Length = 8 inches	61
27. Close Up of T-2-E at Failure	61
28. Bond Failure of T-4-E. Splice Length = 12 inches. Failure Moment = 24.9 kip-ft. Yielding of Tension Steel Was Obvious Prior to Bond Failure	62
29. Diagonal Tension Failure of T-5-E. Splice Length = 14 inches. Failure Moment = 25.0 kip-ft	62
30. Side Split Failure of T-6-E. Splice Length = 4 inches. Failure Moment = 22.0 kip-ft	63

FIGURE	PAGE
31. Top View of T-6-E With Loose Material Removed. Note Ends of Splices	63
32. Close Up of Test Specimen T-2-E Showing External Stirrups Outside Constant Moment Region. Epoxy Concrete Block Is Shown Before Whitewashing	64
33. T-2-E in Test Arrangement	64

CHAPTER I

INTRODUCTION

1.1 Object and Scope of Investigation

The objective of this investigation was to study the relative strength of tension lap splices in concrete and epoxy-strengthened concrete beams. This investigation was deemed worthwhile based upon the following reasoning.

The splicing of deformed bars in reinforced concrete construction, whether necessitated by design considerations or stock length limitations, continues to be an area of active interest to structural engineers.

Over the past 25 years, research conducted on reinforced concrete beams has indicated that the strength of a lap splice is dependent on many factors. Among these are length of lap, lap pattern, spacing of splices, amount of clear cover over the bars, presence of transverse reinforcement, and concrete strength.

Since the mode of failure in the splice zone is essentially one of tensile splitting of the concrete, the tensile strength of the concrete appears to be of primary importance. With this in mind, if the concrete

surrounding the lap splice were replaced by or strengthened with a material having a higher tensile strength than that of concrete, the strength of the member for a given lap length should be increased.

Hence, the objective of this investigation was to study, in a limited way, the relative merit of this hypothesis. The material used to replace the portland cement concrete in the splice zone was an epoxy concrete whose properties are discussed in Chapter II. The scope of the investigation was limited to the variation of one principal factor: length of lap.

To arrive at some comparisons of relative strength, six series of test beams and companion cylinders were cast. Test results and subsequent analysis are given in Chapters III and IV. A comparison of the results from the portland cement concrete beams with a recently proposed formula for the determination of critical splice length is also presented.

1.2 Tension Lap Splices

1.2.1 Basic Theory and Historical Background.

In tension lap splices, transfer of the tensile force from one bar to another is effected by the bond between the deformed bars and the surrounding concrete.

This transfer of force in a lap splice can be depicted as shown in Figure 1.

Prediction of the critical length of lap, l_c , required to enable this stress transfer to take place at yield ($f_s = f_y$) has generally been based on the bar development length, l_d , as determined from various bond tests. The basic equation for computing the

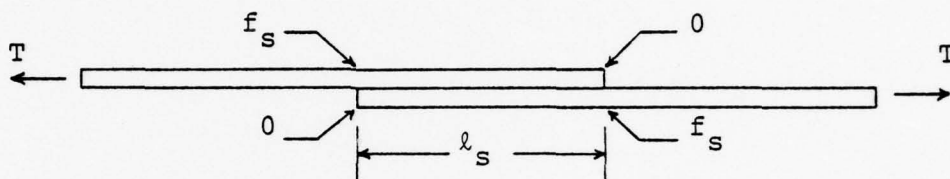

Fig. 1. Stress Transfer in a Tension Lap Splice.

development length for any given steel stress is derived as follows:

$$\text{Bar Tensile Force} = A_b f_s = \Sigma o (l_d) u \quad (1-1)$$

wherein

$$A_b = \text{area of the bar} = \pi d_b^2 / 4,$$

f_s = steel stress,

$$\Sigma o = \text{bar perimeter} = \pi d_b,$$

d_b = bar diameter, and

u = average bond stress over the nominal surface area of the bar.

By substituting the appropriate relationships,

Eq. 1-1 becomes

$$(\pi d_b^2/4) f_s = \pi d_b \ell_d u. \quad (1-2)$$

The development length is then

$$\ell_d = \frac{f_s d_b}{4u} \quad (1-3)$$

The length required to develop the yield stress f_y in the steel when bond failure is imminent (i.e. $u =$ the ultimate bond stress capacity u_u) is

$$\ell_d = \frac{f_y d_b}{4u_u}. \quad (1-4)$$

Ideally, the length of lap required in a splice would be the same as the development length.

In ACI Standard 318-71, Building Code Requirements for Reinforced Concrete (318-71), this concept of development length is addressed in Chapter 12. Splice length, which for design purposes is based on development length, is discussed in Chapter 7. Applicable portions of these chapters are presented in Section 1.2.2 of this thesis.

As mentioned previously, lap splices in reinforced concrete have been the subject of several studies in recent years. In the early 1950's, Chinn, Ferguson, and Thompson (9) conducted a pilot test program at the University of Texas, Austin, to investigate some of the variables affecting the strength

of tension lap splices. These variables included: length of lap, concrete strength, thickness of cover over and under bars, relative strength of spaced and contact splices, effect of beam width per splice, effect of casting bars in the top of the beam, effect of bar size, and effect of stirrups. Thirty-seven beams with tension lap splices in constant moment sections were tested. Some preliminary conclusions concerning the interrelationship of the variables discussed above were derived. Recommendations for future study to confirm test results and to better isolate certain variables were also provided.

At about the same time, research concerning development length, bar spacing, and bond was carried out by S.J. Chamberlin (7,8) and other researchers (12).

The majority of the work done in the 1950's dealt with bar stresses of 50 ksi or less. In the 1960's, research in tension lap splices was expanded to account for the increased use of high strength reinforcing bars with f_y greater than 60 ksi (13, 14, 15).

1.2.2 Current Design Provisions. The current design provisions for development length and splice length have been formulated from earlier code provisions and analysis of subsequent research.

The 1947 ACI Code required that splices provide sufficient lap to transfer stress between bars by bond and shear at an allowable bond stress given as $u = 0.05 f'_c \leq 200$ psi. At the time this provision was written, bars used had deformations which fell far shy of present day requirements. Also, the phenomenon of bond failure was thought to be one in which the reinforcing bar and a cylinder of concrete around it pulled out of the surrounding concrete.

The 1951 ACI Code accounted for the use of improved deformations on bars meeting ASTM Specification A305* bars by increasing the allowable unit bond stress to $u = 0.10 f'_c \leq 350$ psi. Bond failure, however, was still thought to be caused by a pulling out failure.

The provisions of the 1956 ACI Code, Section 506, were basically the same as those of the 1951 Code, however, a minimum overlap for lapped splices was specified as 24 bar diameters, but not less than 12 inches. Ferguson (11) states that this addition to the code was in recognition of the effect bond splitting could have on lowering splice strength.

* American Society for Testing and Materials.
A305. Tentative Specifications for Minimum Requirements for the Deformations of Deformed Steel Bars for Concrete Reinforcement.

Results from bond and splice tests over the years influenced the American Concrete Institute to make major revisions in the bond and splice provisions of the 1963 Code (1). A distinction was made between development bond, calculated from Eq. 1-4, and flexural bond calculated from

$$u = \frac{V}{\Sigma o(jd)} \quad (1-5)$$

in which

V = applied shear force at the section,

Σo = bar diameter = πd_b , and

jd = distance between centroid of tension steel and line of action of resultant compression forces.

The permissible ultimate bond stress was set at $9.5\sqrt{f'_c}/d_b \leq 800$ psi, and, in effect, the permissible ultimate development-bond stress was set at 0.3 of this.

Concern about splitting in splices was shown by limiting the bond stress in lap splices to 3/4 of the permissible bond values given above and requiring minimum lap lengths of 24, 30, and 36 bar diameters for specified yield strengths of 40, 50, and 60 ksi,

respectively, as well as 12 inches as another minimum. Further, the length was to be increased 20 percent for contact splices spaced closer than 12 bar diameters.

The form of the bond and splice provisions of the 1971 ACI Code (2) was drastically changed, but the end effect was essentially the same as that produced by the more conservative provisions of the 1963 Code.

Designers had sometimes checked only flexural bond and had sometimes neglected to provide adequate bar anchorage or development length. Since the latter was considered the more important, the 1971 Code provisions were expressed in terms of development length rather than bond stress. By the 1963 Code, flexural bond was not limited if anchorage bond did not exceed 0.8 times the permissible stress of $9.5\sqrt{f'_c}/d_b \leq 800$ psi. This leads to a development length, l_d , as follows:

$$\begin{aligned} l_d &= \frac{f_s d_b}{4u} = \frac{f_y d_b}{4(0.8)9.5\sqrt{f'_c}/d_b} \geq \frac{f_y d_b}{4(0.8)(800)} \\ &= \frac{\frac{\pi^2}{4} d_b^2 f_y}{\pi^2 (7.6) \sqrt{f'_c}} \geq \frac{f_y d_b}{256} \\ &= 0.0418 f_y A_b / \sqrt{f'_c} \geq 0.00039 f_y d_b \end{aligned}$$

These numbers are rounded off in the Code to give

$$\ell_d = 0.04f_y A_b / \sqrt{f'_c} \geq 0.0004f_y d_b. \quad (1-6)$$

When less than half the bars are spliced in a region of high stress, the splice length must be at least $1.3\ell_d$. This is the equivalent of permitting only 3/4 the permissible bond stress in a splice. When more than half the bars are spliced in a region of high stress, the splice length must be at least $1.7\ell_d$. This is a bit more conservative than the 20 percent extra lap length requirement of the 1963 Code for splices spaced closer than 12 bar diameters.

1.2.3 Recent Developments. Some of the more recent work done in the area of tension lap splices has been in the prediction of the critical lap length required to develop yield stress in the reinforcement prior to splitting failure in the splice zone (18,19).

In January 1975, C.O. Orangun, J.O. Jirsa, and J.E. Breen (18) issued a research report titled "The Strength of Anchored Bars: A Reevaluation of Test Data on Development Length and Splices." A condensed version of this report was published in the March 1977 issue of the Journal of the American Concrete Institute (19).

In this report, an expression for average ultimate bond stress as a function of bar diameter,

splice length, and amount of cover was developed by nonlinear regression analysis of results from 62 beams previously tested by various researchers. Of the functions investigated the simplest function was chosen.

The expression derived is

$$u^*/\sqrt{f'_c} = 1.22 + 3.23C/d_b + 53.0d_b/\ell_s \quad (1-7)$$

wherein

u^* = the average ultimate bond stress (psi) in splices for beams with constant moment over the splice length,

C = the smaller of the clear bottom cover, C_b , or half the clear spacing C_s between the next adjacent bar,

ℓ_s = the splice length,

d_b = the bar diameter, and

f'_c = the concrete compressive strength in psi.

From a simplified form of this expression, modified to account for the presence of stirrups, an equation was derived for calculating development lengths for deformed bars. The equation developed was

$$\ell_d = \frac{\left[d_b \frac{f_s}{4\sqrt{f'_c}} - 50 \right]}{\left[1.2 + 3C/d_b + \frac{A_{tr} f_{yt}}{500s d_b} \right]} \quad (1-8)$$

in which

A_{tr} = area of transverse reinforcement
normal to the plane of splitting
through the anchored bars,

s = center to center spacing of transverse
reinforcement, and

f_{yt} = yield strength of transverse
reinforcement.

This equation reflects the effect of lap length, cover, bar spacing, bar diameter, concrete strength, transverse reinforcement, and moment gradient on lap splice strength.

It is significant to note that in their analysis, Orangun, et al., found the development length and splice length to be identical.

A comparison of strength predicted by Eq. 1-7 with results of the present tests is presented in Chapter IV.

1.3 Epoxy

Epoxies are a group of synthetic resins, usually produced by condensation of Bisphenol A and Epichlorhydrin. Their first successful application was in the coatings field, primarily due to the high resistance of epoxies to acids, alkalies, oils, and solvents. Epoxies possess many characteristics that make them desirable for use with concrete. Included among these properties are: adhesion, inertness, low

shrinkage, strength, toughness, resilience, and versatility. Epoxies first found acceptance in the building and construction industry as a concrete bonding adhesive in the mid-1950's. Since their introduction into the construction industry, the use of epoxy systems has grown rapidly. Today, they are used in a wide range of applications including: surface treatments for concrete pavements, bonding adhesives for bonding plastic concrete to hardened concrete, structural repair of cracked concrete, patching and grouting, wearing surfaces, and seal coats.

In general, an epoxy system consists of two basic components--an epoxy resin and a chemically reactive curing agent or hardener. The epoxy resin is mixed with the hardener which causes it to polymerize into a strong, tough plastic. At room temperature, the epoxy resin and hardener usually become touch-dry within a few hours, and the compound completely cures in one to two weeks. The properties of the cured resin can be altered by proper choice of resin, additives, curing agent, and curing procedures. This versatility allows for the formulation of the "right" epoxy system for any particular application.

The epoxy compound used in this study was donated by its manufacturer, PROTEX Industries, Inc., Denver, Colorado, and is designated as PROBOND ET-180. Its basic components are diglycidyl ether of bisphenol A with a polymeric amido-amine as a hardener. Typical properties of the epoxy resin and hardener as well as properties of the cured compound are given in Chapter II. Test results for tensile strength of the epoxy concrete (epoxy resin, hardener, sand, and gravel) used in the test beams are presented in Chapter III.

In general, the economics of epoxy resin compounds has dictated that their use be supplementary to and not in place of concrete. The use of fillers to produce desired properties, however, has also served to improve economics.

CHAPTER II

TEST PROGRAM

As stated previously, the primary objective of this investigation was to compare the load-carrying capacity of concrete and epoxy-strengthened beams for varied lengths of reinforcement lap. To evaluate splice strengths, six series of test beams and companion test cylinders were cast. Each test series consisted of:

- (1) a reinforced concrete "control" beam,
- (2) a reinforced concrete beam with an epoxy concrete block cast around the tension lap splices (Figure 2),*
- (3) three 6 x 12 concrete cylinders to evaluate concrete compressive strength,
- (4) three 3 x 6 concrete cylinders to evaluate concrete tensile strength, and
- (5) three 3 x 6 epoxy concrete cylinders to evaluate epoxy concrete tensile strength.

All specimens were tested eight days after they were cast.

* Hereafter, this beam will be referred to as the "epoxy beam."

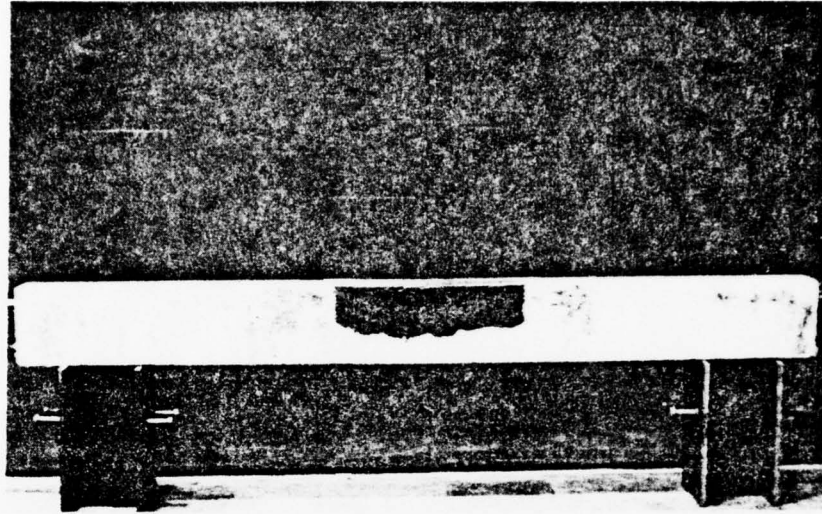

Fig. 2. Test Beam (Tension Side Up) Showing Epoxy Concrete Block Cast Around Lap Splices.

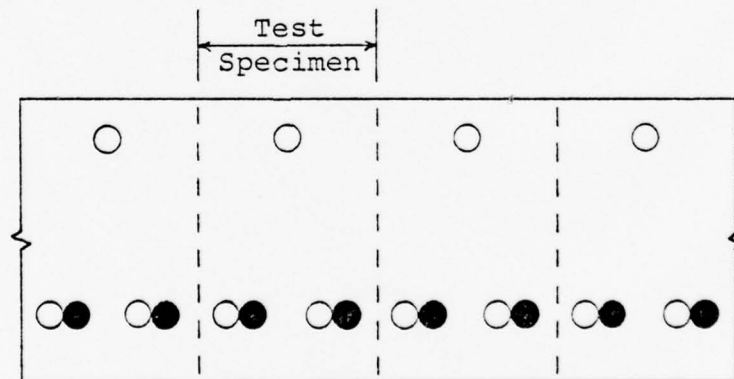

Fig. 3. Repeating Section Used for Beam Design.

2.1 Test Specimens

The cross section chosen for the test specimens was representative of the interior of a beam without stirrups, with splices as close together as is permitted by the Code (Figure 3). This is probably the worst condition which would be encountered in a beam. The actual reinforcement arrangement in the test beams (Figure 4) was kept symmetrical, however.

2.1.1 Geometry and Details. In making the test specimens, the following construction aspects were kept constant:

- (1) Concrete mix design--Appendix B.
- (2) Epoxy concrete mix design--Appendix B.
- (3) Beam dimensions (nominal)--depth = 8 inches, width = 5 inches, length = 7 feet.
- (4) Reinforcement.
 - a. Tension steel--two #6 Grade 60 bars lap spliced in a constant moment section.
 - b. Compression steel--one #6 Grade 60 bar.
 - c. Web reinforcement--fabricated from welded wire fabric furnished by Stanley Structures, Denver, Colorado.
- (5) Reinforcement location.
 - a. Depth to centroid of tension steel--6-1/8 inches.

b. Depth to centroid of compression steel--1-1/8 inches.

c. Lateral location of tension steel--1/2 inch side cover on outer bars, spliced bars in contact, 1 inch clear spacing between splices.

(6) Curing time--eight days.

(7) Dimensions of epoxy concrete block--depth = 5 inches, width = 5 inches, length = lap length plus 2-1/2 inches on each end.

All beams were cast in plywood forms. Tensile reinforcement was supported by plastic reinforcing bar chairs (donated by Stanley Structures) and extended through holes in the end forms. All splices were contact splices tied in two places with soft-wire ties.

Nominal beam dimensions and reinforcement location are illustrated in Figure 4. Test beam details are provided in Table I.

2.1.2 Materials.

(1) Concrete. The same concrete mix proportions given in Appendix B were used for the concrete in all the test specimens. All cement was Martin Marietta Type I Portland Cement. A change in lot numbers was required during the course of this investigation; however, no notable changes in concrete strength were observed due to the change. Locally-procured sand and gravel were used. The proportions

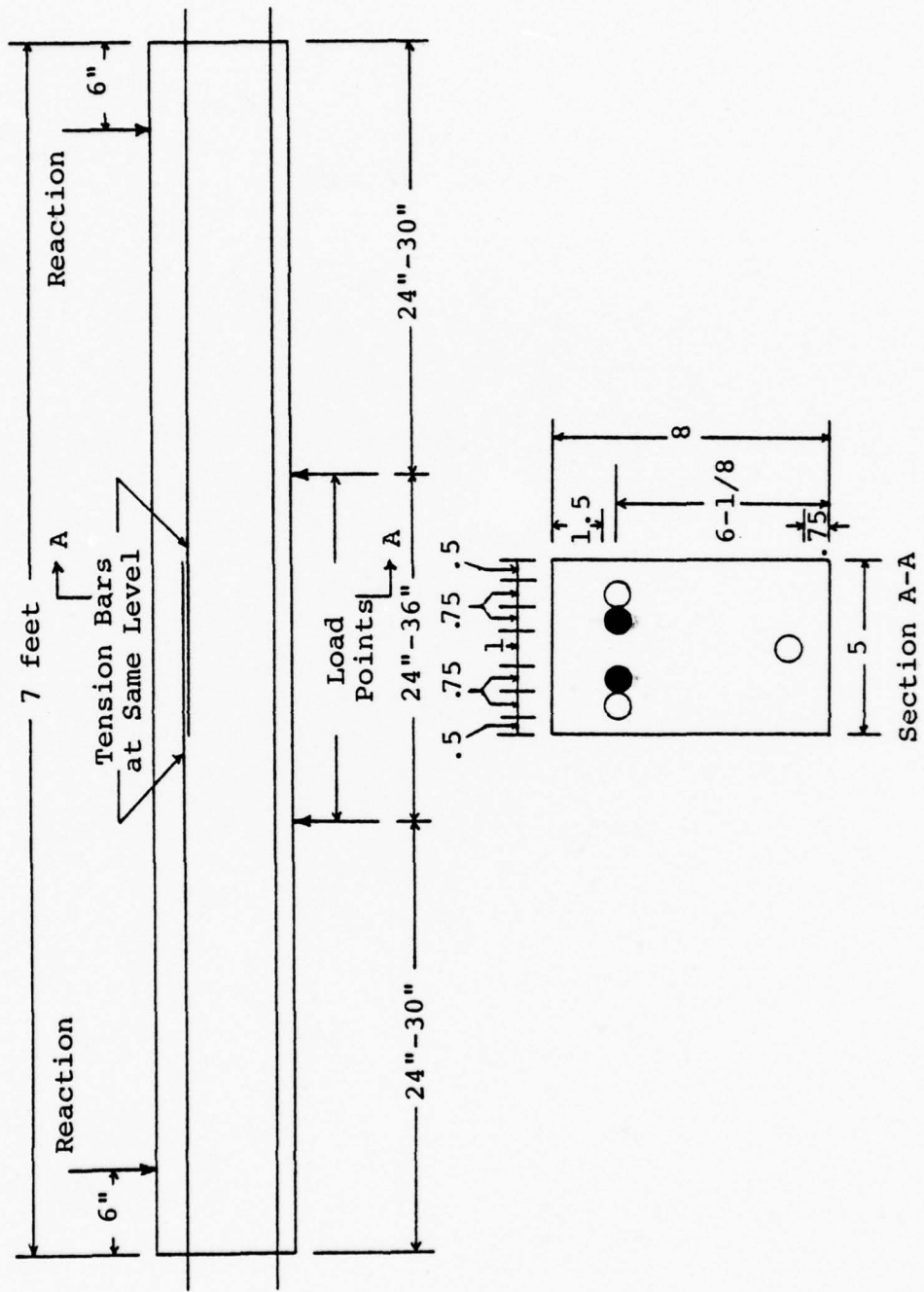

Fig. 4. Nominal Beam Dimensions (Inches) and Reinforcement Location.

TABLE I
TEST BEAM DETAILS

Test Beam Designation	Beam Test Length (ft.)	Shear Span (in.)	Constant Moment Region (in.)	Lap Splice (in.)	Concrete Properties*		Epoxy Tensile Strength* (psi)	Steel Yield Strength* (ksi)	
					f'c (psi)	f't (psi)			
T-1-C	6.0	18.0	36.0	12.0		5090	655	--	65.5
T-1-E	6.0	18.0	36.0	12.0		5090	--	1640	65.5
T-2-C	6.0	24.0	24.0	8.0		5032	575	--	65.5
T-2-E	6.0	24.0	24.0	8.0		5032	--	1630	65.5
T-3-C	6.0	24.0	24.0	16.0		5353	453	--	65.5
T-3-E	6.0	24.0	24.0	16.0		5353	--	1453	65.5
T-4-C	6.0	24.0	24.0	12.0**		5050	585	--	65.5
T-4-E	6.0	24.0	24.0	12.0		5050	--	1790	65.5
T-5-C	6.0	24.0	24.0	14.0		5053	603	--	65.5
T-5-E	6.0	24.0	24.0	14.0		5053	--	1735	65.5
T-6-C	6.0	24.0	24.0	6.0		4957	628	--	65.5
T-6-E	6.0	24.0	24.0	4.0***		4957	--	1725	65.5

*Determined by tests.

**A 12-inch splice length was repeated in this test series with an increased shear span to avoid early bond failure as experienced in Test Series #1.

***A different lap splice length was used for the epoxy beam in Test Series #6 in an attempt to induce failure in the splice zone. This length was chosen based on test results of previous beams.

of coarse and fine aggregate were constant, but the gradation of the fine aggregate was changed slightly for Test Series 5 and 6 as noted in Appendix B. City water was used for mix water. The concrete was mixed in a six cubic foot capacity tilting drum mixer (Essick, Model 62 BE).

(2) Epoxy concrete. The epoxy concrete used in this investigation consisted of two basic components, PROBOND ET-180 and aggregate filler as described below:

Epoxy Cement:

Part A--diglycidyl ether of bisphenol A.

Typical physical constants provided by the manufacturer are:

Viscosity @25°C 13,000 cps

Wt/Gal 9.63 lbs

Wt/Epoxide 190 lbs

Part B--polymeric amido-amine (Poly Amide type).

Typical physical constants provided by the manufacturer are:

Viscosity 25,000 cps

Wt/Gal 8.15 lbs

Equivalent weight 116 lbs (approx.)

Aggregate:

Fine aggregate--locally acquired sand blended as described in Appendix B.

Coarse aggregate--local material blended as indicated in Appendix B.

Typical properties of the cured epoxy compound (Part A plus Part B) as given by the manufacturer are:

Ultimate tensile strength	8,300 psi
Tensile elongation	4.6%
Ultimate flexural strength	13,000 psi
Compressive yield strength	10,300 psi

The epoxy concrete mix design is given in Appendix B.

(3) Reinforcement. All tension and compression reinforcement consisted of #6 Grade 60 bars with an average yield stress of 65.5 ksi. A typical stress-strain curve is shown in Figure 5. Figure 6 is a photograph of the deformed bars, produced by Border Steel Mills, Inc., El Paso, Texas. The modulus of elasticity of the steel was about 29,000 ksi for all tests.

Web reinforcement was fabricated from welded wire fabric donated by Stanley Structures.

2.1.3 Specimen Fabrication. The sequence for specimen manufacture generally followed the outline below:

(1) Formwork was assembled and waxed with a commercial paste wax. Plastic sheets were taped to

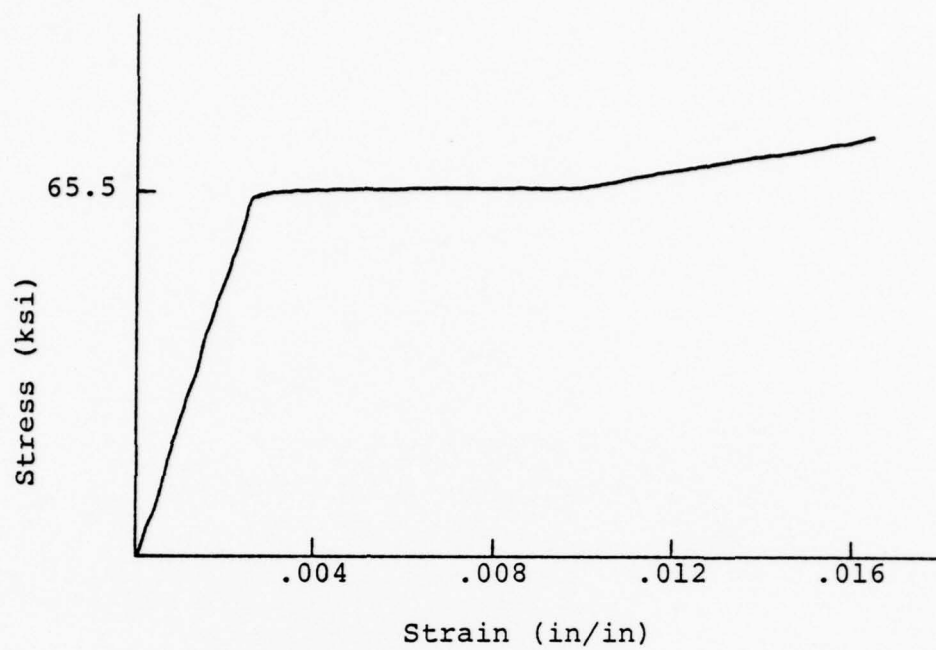

Fig. 5. Steel Stress-Strain Curve.

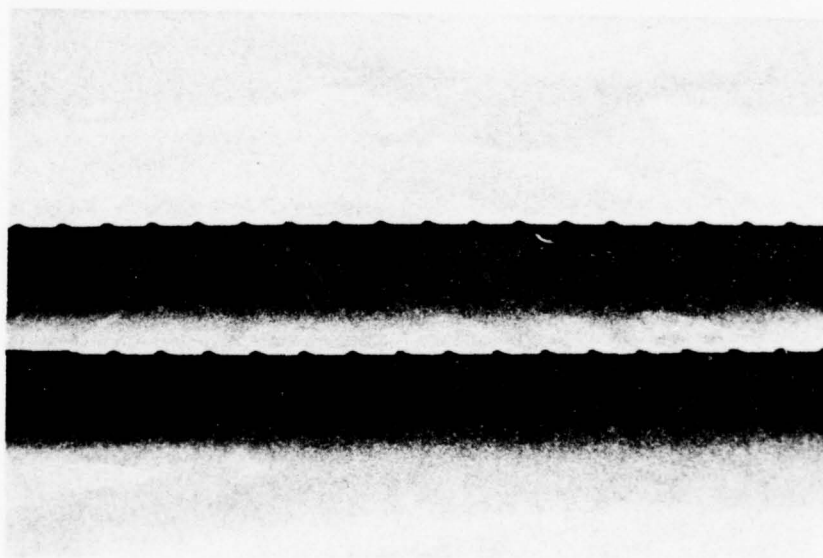

Fig. 6. Photograph of #6 Bars Used in Tests.

the side forms and bottom form of the epoxy beam to prevent epoxy from leaking from the formwork while in the liquid state.

(2) Tension reinforcement was placed in both beams, lapped the desired amount, and tied.

(3) Compression reinforcement and web reinforcement were placed and tied in the concrete beam form, but not in the epoxy beam form at this time.

(4) Temporary end forms were placed in the epoxy beam approximately 2-1/2 inches from each end of the lap (Figure 7) to form the epoxy concrete block.

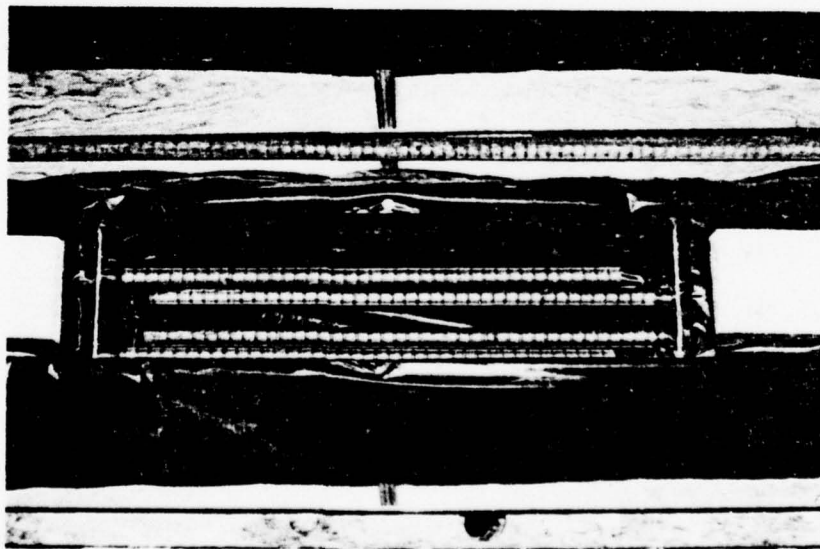

Fig. 7. Temporary End Forms in Place in Epoxy Beam.

(5) The epoxy system was mixed in accordance with the manufacturer's recommendations as follows: Part A and Part B were placed in a ten-gallon mixing container and stirred for approximately three minutes or until uniformly blended. Mixing was done by hand or with the aid of a specially made stirrer rotated by a variable-speed, high-torque 3/8 inch power drill (Figure 8). This blend was allowed to set for five minutes without further agitation. Then the coarse and fine aggregate were added. The epoxy concrete was thoroughly mixed to ensure adequate coating of all particles. Total mixing time was approximately 25 minutes.

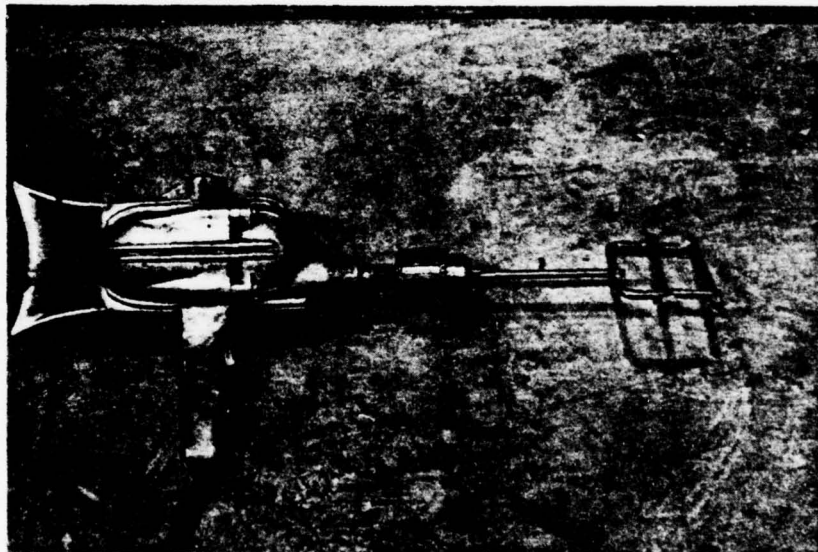

Fig. 8. Power Drill and Mixing Stirrer.

(6) The epoxy system was then hand-placed in the splice zone in three equal layers to a depth of 5 inches. Each layer was rodded and internally vibrated using a Model L, Viber Company, vibrator. Three companion 3 x 6 cylinders were prepared in accordance with ASTM Method C192-69, "Standard Method of Making and Curing Concrete Test Specimens in the Laboratory" (6). Molds for these cylinders were encased in plastic bags to preclude leakage of liquid epoxy.

(7) The epoxy concrete block was allowed to set for approximately thirty minutes while the portland cement concrete was prepared. The temporary end forms were then removed, and the compression and web reinforcement were placed in the epoxy beam.

(8) Concrete was then placed in both beams in three equal layers. Each layer was rodded and internally vibrated. Three 6 x 12 and three 3 x 6 cylinders were cast in metal molds.

(9) The beams and cylinders then were covered with plastic and allowed to cure one day in their forms. On the second day, the specimens were removed from the forms and cured for an additional seven days as illustrated in Figure 9. The specimens were tested on the eighth day.

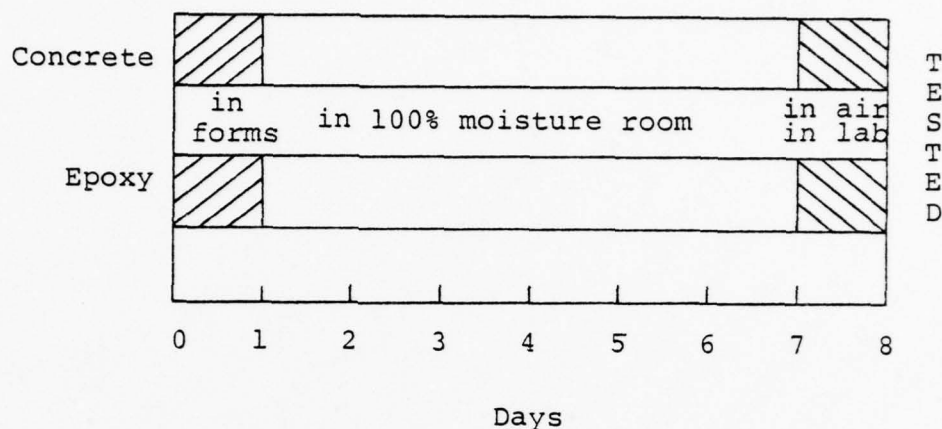

Fig. 9. Specimen Curing Cycle.

2.2 Test Procedure

2.2.1 Cylinders. Cylinders were tested in a 300 k capacity Southwark-Baldwin-Emery universal testing machine. The compression cylinders (concrete) were capped with Cylcap, a commercial sulfur fire capping compound, and tested in accordance with ASTM Method C39-72, "Standard Method of Test for Compressive Strength of Cylindrical Concrete Specimens" (6). The tensile strengths of the concrete and epoxy concrete were determined by split-cylinder tests conducted as specified in ASTM Method C496-71, "Standard Method of Test for Splitting Tensile Strength of Cylindrical Concrete Specimens" (6).

2.2.2 Test Beams. Prior to testing, the beam specimens were "whitewashed" with a thin plaster of paris solution to facilitate observation and recording of crack progression. All beams were tested, tension side up, over a six foot span on the University of Colorado structural test floor. The test arrangement is shown in Figure 10. The ends of the beams were held down by an arrangement of steel double channels secured to the structural test floor with 1-1/8 inch tension tie rods. Load was applied by use of two 60 k capacity hydraulic jacks (Simms Engineering Co.) connected to a common manifold at the hydraulic hand pump (Templeton, Kenly & Co.). Load increments applied varied in the test beams dependent upon anticipated failure load. Load measurements were taken by means of a 100 k capacity BLH C2P1 load cell which was installed on top of the west hydraulic jack. The load cell was electrically connected to a companion load guage which indicated applied load on a dial. The east hydraulic jack was placed on top of a wide flange beam section so that its top was at the same level as the top of the load cell.

Roller arrangements were placed between the tension side of the test beam and the steel double

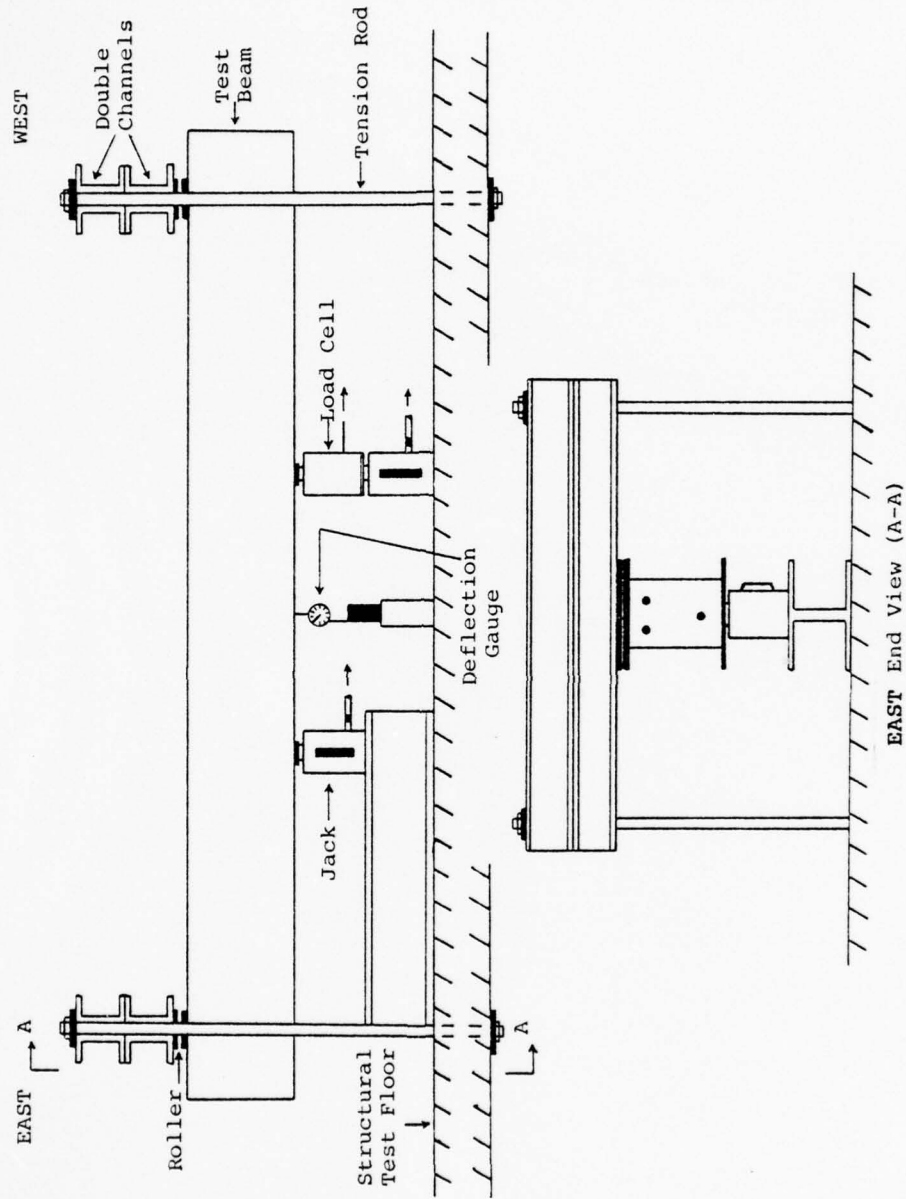

Fig. 10. Test Arrangement.

channels to permit free rotation of the test specimen at the supports. Figure 11 is a photograph of test beam T-1-C in the test arrangement.

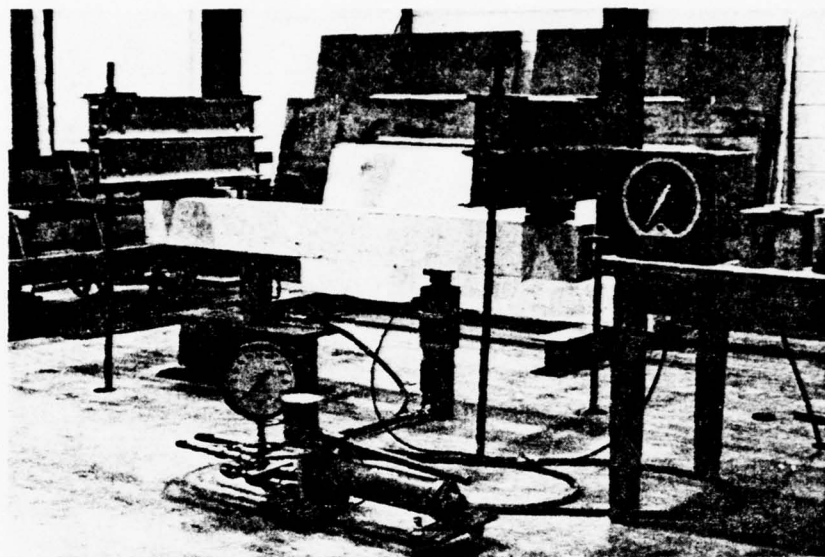

Fig. 11. Test Beam T-1-C in Test Arrangement.

Deflection measurements were taken at midspan for several of the test series to determine the relative stiffness of the two beam types. These measurements were obtained from a deflection dial set under the beam (Figure 10).

Photographs were taken of the concrete and epoxy beams at comparable loads and at failure.

The data recorded during testing are reproduced at Appendix D. A synopsis of the key details of each test is given in Chapter III.

2.3 Anticipated Results

2.3.1 Cylinders. Since the concrete was designed for a seven-day compressive strength of 4600 psi, the 6 x 12 cylinders, when tested in compression at eight days, ideally should yield values in excess of 4600 psi. The actual compressive strengths attained are given in Chapter III.

For concrete compressive strength assumed to be 4600 psi, the anticipated tensile strength is $f'_t = 6.7\sqrt{f'_c} = 6.7\sqrt{4600}$ or 454 psi. For the average compressive strength actually obtained, $(f'_c)_{avg} = 5100$ psi, the tensile strength of the concrete should be around 480 psi. Test results for the split-cylinder tests are in Chapter III.

In Section 2.1.2, a typical value for the tensile strength of the cured epoxy resin was given as 8300 psi. With the addition of sand and gravel as fillers, the tensile strength of the epoxy concrete should be less than this value. Determination of the resultant tensile strength of the epoxy concrete was one of the implied objectives of this investigation. Test results are given in Chapter III.

2.3.2 Test Beams. The development length required by the 1971 ACI Building Code (1) for a #6 bar to develop a yield stress of 60 ksi is 18 inches

(Eq. 1-6). For a beam with adequate cover, the design splice length for #6 bars lapped in a constant moment section where more than one-half the bars are lapped within a required lap length would be 1.7(18) or 30.6 inches. Since all lap splices used in the present investigation were 16 inches or less in length, some type of failure would be expected to take place in the splice zone before the tensile reinforcement yielded (at least for the concrete beams). Because the amount of side cover ($1/2$ inch) was less than the amount of bottom cover ($1-1/2$ inches), the predominant mode of failure anticipated would be "side split failure" as opposed to "face-and-side split failure" (19). These common modes of concrete splitting in tension lap splices are illustrated in Figure 12.

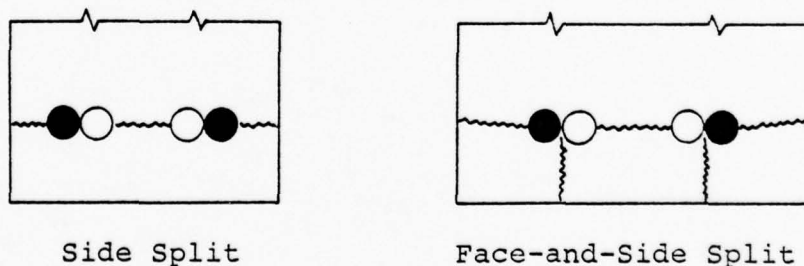

Fig. 12. Common Failure Patterns.

Additionally, an increase in splice strength would be expected with increase in lap length.

For a given length of lap the epoxy test beam should theoretically exhibit greater strength than the corresponding concrete beam. The purpose of this investigation was to determine these relative strengths. Test results and subsequent analysis and discussion are presented in the following chapters.

CHAPTER III

TEST RESULTS

For ease of presentation, test results have been organized in tabular form where appropriate.

3.1 Compression Tests

The results of the concrete cylinder compression tests are presented in Table II. The concrete was designed for a seven-day compressive strength of 4600 psi. The average eight-day compressive strength obtained was 5089 psi. Fourteen of the eighteen cylinders tested had compressive strength values between 4860 psi and 5270 psi.

3.2 Split-Cylinder Tests

The results of the split-cylinder tensile strength tests are contained in Table III. The average splitting tensile strength for the concrete was 583 psi. The average split-cylinder tensile strength of the epoxy concrete was 1662 psi.

TABLE II
 CONCRETE CYLINDER DATA--COMPRESSION TESTS

Test Series	Specimen Designation	Length (in.)	Diameter (in.)	Cross-Sectional Area (sq. in.)	Max. Load (lbs.)	Compressive Strength f'_c (psi)*
T-1	1	12.00	6.20	30.19	159,000	5270
	2**	12.00	6.20	30.19	143,600	4760
	3	11.98	6.24	30.58	150,300	4910
T-2	1	12.04	6.20	30.19	153,000	5070
	2	11.95	6.22	30.39	136,000	4475
	3	11.98	6.20	30.19	167,500	5550
T-3	1	11.95	6.25	30.68	154,500	5040
	2	12.00	6.20	30.19	157,000	5200
	3	12.05	6.22	30.39	177,000	5820
T-4	1	12.00	6.21	30.29	154,000	5080
	2	12.00	6.26	30.78	152,000	4940
	3	12.00	6.20	30.19	155,000	5130
T-5	1	12.06	6.28	30.97	160,250	5170
	2	12.03	6.26	30.78	150,000	4870
	3	12.07	6.23	30.48	156,000	5120

TABLE II (continued)

Test Series	Specimen Designation	Length (in.)	Diameter (in.)	Cross-Sectional Area (sq. in.)	Max. Load (lbs.)	Compressive Strength f'_c (psi)*
T-6	1	11.95	6.20	30.19	154,500	5120
	2	11.95	6.20	30.19	147,500	4890
	3	12.00	6.30	31.17	151,500	4860

*All specimens tested eight days after being cast

**Poorly capped cylinder; not averaged in test results

TABLE III
 CONCRETE AND EPOXY CYLINDER DATA--SPLIT-CYLINDER TESTS

Test Series	Specimen Designation	Length (in.)	Diameter (in.)	Max. Load (lbs.)	Splitting Tensile Strength (psi)	Comments
T-1	C1	5.97	2.97	18,175	655	
	C2	6.00	2.98	17,200	610	
	C3	5.99	2.98	19,575	700	
	E1	6.00	3.00	45,750	1,620	
	E2	6.00	2.96	46,750	1,675	
	E3	6.00	2.99	45,750	1,625	
T-2	C1	5.96	2.99	15,625	560	
	C2	5.87	3.03	17,200	615	
	C3	5.96	3.01	15,450	550	
	E1	5.96	3.00	48,400	1,725	
	E2	5.97	2.98	43,700	1,565	
	E3	5.98	3.00	45,000	1,600	
T-3	C1	6.05	2.97	14,750	525	
	C2	6.07	2.97	11,350	400	only $\frac{1}{2}$ cylinder split
	C3	6.07	2.95	12,225	435	only $\frac{1}{2}$ cylinder split
	E1	6.00	2.99	41,600	1,475	
	E2	6.00	2.98	40,200	1,430	
	E3	6.00	2.95	26,400	950	only $\frac{1}{2}$ cylinder split*

TABLE III (continued)

Test Series	Specimen Designation	Length (in.)	Diameter (in.)	Max. Load (lbs.)	Splitting Tensile Strength (psi)	Comments
T-4	C1	6.00	2.96	16,300	585	unusual fracture*
	C2	5.95	2.95	11,800	430	
	C3	6.00	2.96	16,350	585	
	E1	6.00	2.97	50,000	1,785	
	E2	5.98	2.98	50,250	1,795	
	E3	6.00	2.98	--	--	
T-5	C1	5.98	2.96	14,250	515	poorly cast specimen*
	C2	5.96	2.95	17,200	625	
	C3	6.00	2.97	18,750	670	
	E1	6.02	3.00	51,500	1,820	
	E2	6.00	3.00	50,000	1,770	
	E3	6.00	3.00	45,800	1,615	
T-6	C1	5.97	3.00	15,100	535	unusual fracture*
	C2	5.97	2.95	17,625	640	
	C3	5.97	2.95	19,600	710	
	E1	6.00	2.95	37,050	1,335	
	E2	6.00	2.95	49,000	1,760	
	E3	6.05	3.00	48,250	1,690	

*Not averaged in test results

- Notes: 1. Curing history as outlined in Section 2.1.3.
 2. All specimens tested eight days after being cast.
 3. Generally, 95-100% of the coarse aggregate in the fracture plane split.
 4. Unusual fracture or specimen defects are noted in the "Comments" above.

3.3 Test Beams

The beam specimens were tested in the test arrangement shown in Figures 10 and 11. Although the test shear span varied, the distance between the two loading jacks was always greater than the splice length. The data recorded during the test of each specimen are reproduced in Appendix D. Key details of all tests are presented in the following synopses.

(1) T-1-C: Test beam T-1-C, with a splice length of 12 inches, was tested with a shear span of 18 inches. Load increments of 1 kip were used until a load of 3 kips per jack (kpj) was applied. At this load, flexure cracks developed directly over the loading jacks. At a load of 3.25 kpj, flexure cracks were observed in the vicinity of the ends of the splices. Diagonal tension cracking began at a load of 5 kpj. At an applied jack force of 5.5 kpj, additional flexural cracking developed in the splice zone. Side split failure occurred at an applied load of 8.5 kpj. No horizontal* splitting of the concrete along the reinforcement plane was observed prior to failure.

*Splitting on the side of the beam in the splice zone along the plane of the tensile reinforcement.

(2) T-1-E: Test beam T-1-E, with $l_s = 12$ inches, was also tested with a shear span of 18 inches. Since the tensile strength of the epoxy concrete cylinders for this initial test series was approximately 2.5 times that of the concrete, a failure load in excess of 8.5 kpj was anticipated. At a load of 4 kpj, flexural cracking was evident over the loads and at the concrete-epoxy concrete interface. Diagonal tension cracks were observed at a load of 7 kpj. At an applied jack force of 10 kpj, bond splitting from the diagonal tension cracks was evident. At a load of 11.5 kpj, a flexure crack was seen in the epoxy concrete in the center of the splice zone. The formation of this crack was announced by a loud "pop." Bond/diagonal tension failure of the east end of the beam occurred at an applied load of 14.85 kips per jack.

(3) T-2-C: Beam T-2-C, with a splice length of 8 inches, was tested with a shear span of 24 inches. Flexural cracking over the loads and at the ends of the splices occurred at loads of 2.5 kpj and 3.0 kpj, respectively. Horizontal cracking in the splice zone began at a load of 4.5 kpj. As result of this cracking, the load reading dropped to 4.3 kpj. While attempting to reload the beam to 4.5 kpj, side split failure occurred.

(4) T-2-E: Beam T-2-E, with $l_s = 8$ inches, was also tested with a shear span of 24 inches. (Note: all subsequent test series were tested with a shear span of 24 inches.) Flexural cracking of the concrete over the loading jacks occurred at a load of 2.5 kpj. At an applied load of 5 kpj, diagonal tension cracking was noted. Cracking at the concrete-epoxy concrete interface occurred at a load of 9 kpj. At a load of 9.75 kpj, bond splitting began to develop from the diagonal tension cracks. The first crack in the epoxy concrete block, again announced by a loud "pop," occurred in the center of the splice zone at a load of 10.05 kpj. By the time the load had reached 11.4 kpj, an extensive bond/diagonal tension crack network had developed in the shear spans. A second crack in the epoxy concrete block over the east end of the splice zone occurred at a load of 12.75 kpj. Yielding of the tension steel was obvious at a load of 13.175 kips per jack. The load reading dropped to 12.65 kpj. At a load of 12.7 kpj, while attempting to reload the beam, a third crack in the epoxy concrete block developed near the west end of the splice zone. Loading was discontinued after repeated attempts to load the beam with more than 13.4 kips per jack. Due to yielding of the tension steel, a constant load could not be maintained above 12.6 kpj.

(5) T-3-C: This specimen had a lap splice length of 16 inches. Flexural cracks over the loading jacks and at ends of the splices occurred at loads of 2 kpj and 2.5 kpj, respectively. Additional flexure cracks were observed in the center portion of the splice zone at a load of 3.5 kpj. At an applied jack force of 5.25 kpj, face splitting began between the two splices (as opposed to directly over the splices). Horizontal cracking in the splice zone along the reinforcement plane was visible at a load of 5.5 kpj. Diagonal tension cracking began at a load of 6.0 kpj. At an applied load of 6.25 kpj, additional horizontal splitting was observed in the splice zone. Side split failure occurred at a load of 6.5 kips per jack. Face splitting (a single crack) was evident for approximately seventy percent of the splice length.

(6) T-3-E: Beam T-3-E, with $l_s = 16$ inches, developed flexural cracks over the loading jacks at a load of 4.0 kpj. At an applied load of 9.5 kpj, an extensive diagonal tension crack network was evident. The first crack in the epoxy concrete block occurred near the east end of the splice zone at a load of 11.5 kpj. Bond cracking began at a load of 12 kpj. At a load of 12.4 kpj, a second crack in the epoxy concrete block developed near the west end of the splice. The test was discontinued at a load of

12.975 kips per jack when it was obvious that the tension steel was yielding.

(7) T-4-C: A lap splice length of 12 inches was repeated in this test series using a shear span of 24 inches to avoid early bond failure as experienced in Test Series #1 in the epoxy beam. Flexure cracks over the loading jacks were noted at a load of 2.0 kpj. At a load of 3.5 kpj, flexural cracking in the splice zone was observed. Longitudinal cracking in the splice zone developed at a load of 5.25 kpj. Side split failure occurred at a load of 5.5 kips per jack.

(8) T-4-E: Beam T-4-E also had a lap length of 12 inches. Flexural cracks over the load points occurred at a load of 2.0 kpj. Cracking at the concrete-epoxy concrete interface was observed at a load of 5.5 kpj. At a load of 7.5 kpj, diagonal tension cracks began to form. Bond cracking from the diagonal tension cracks occurred at 8.5 kpj. The first crack in the epoxy concrete block occurred in the center of the splice zone at a load of 9.7 kpj. The second crack in the epoxy concrete block was detected at a load of 11.9 kpj. At a load of approximately 12.4 kpj, it was evident that the tension steel was yielding. Repeated attempts to reload the beam past 12.45 kpj were futile. Each time after reloading, the load would drop off to about 10.0 kpj. After repeated

loading, a bond/diagonal tension failure occurred in the west shear span of the beam.

(9) T-5-C: Beam T-5-C, with a splice length of 14 inches, followed the now familiar pattern of the previous concrete beam specimens. Horizontal cracking in the splice zone, however, began at the relatively low load of 3.5 kpj. Side split failure occurred at a load of 5.75 kips per jack.

(10) T-5-E: Test specimen T-5-E, with $l_s = 14$ inches, first cracked in the epoxy concrete block at a load of 9.85 kpj. A second crack in the center of the splice zone was detected at a load of 11.0 kpj. A diagonal tension failure of the east shear span of the beam occurred at a load of 12.5 kips per jack.

(11) T-6-C: For beam T-6-C, with a splice length of 6 inches, flexural cracking at the ends of the splices developed at a load of 3.0 kpj. Side split failure occurred at a load of 3.875 kips per jack with no prior indication of horizontal cracking in the splice zone.

(12) T-6-E: For this final test series, in hopes of obtaining a side split failure in the splice zone of an epoxy beam, test specimen T-6-E was cast with a 4-inch splice as opposed to the 6-inch splice used in the "companion" concrete test beam. At a

load of 3.0 kpj, flexural cracking was observed over the loading jacks. Flexural cracks at the concrete-epoxy concrete interface were noted at a load of 4.0 kpj. Little additional cracking was evident until side split failure occurred in the splice zone at an applied jack force of 11.0 kips per jack. Prior to actual failure, no flexural cracking was found in the epoxy concrete block. Failure was catastrophic with small chunks of the epoxy concrete over the bars being thrown more than a foot in the air above the beam. Failure occurred after the load had been applied and held for approximately 30 seconds.

Results of the beam specimen tests are summarized in Table IV.

The load values given in the table were obtained from the BLH C2P1 load cell and verified with readings from the load gauge on the hydraulic pump.

Moment values were computed from the load values and the respective beam shear span.

The steel stress at failure, f_s , was calculated as follows:

$$f_s = \frac{M}{A_s(jd)} \quad (3-1)$$

TABLE IV
TEST BEAM RESULTS

Test Beam Designation	Lap Splice (in.)	Ultimate Load (kips)	Ultimate Moment (kip-st)	Steel		Average Bond Stress u(calc) (psi)	Type Failure
				f_s (calc) (ksi)	Stress f_s (ksi)		
T-1-C	12.0	8.500	12.75	33.4	521.8	side split	
T-1-E	12.0	14.850 (11.500)*	22.28 (17.25)*	58.3 (45.2)*	910.9 (706.3)*	bond/diagonal tension	
T-2-C	8.0	4.500	9.00	23.6	553.1	side split	
T-2-E	8.0	13.400 (10.050)	26.80 (20.10)	70.2** (52.6)	1645.3 (1232.8)	yield	
T-3-C	16.0	6.500	13.00	34.0	398.4	side split	
T-3-E	16.0	12.975 (11.500)	25.95 (23.00)	67.9** (60.2)	795.7 (705.5)	yield	
T-4-C	12.0	5.500	11.00	28.8	440.6	side split	
T-4-E	12.0	12.450 (9.700)	24.90 (19.40)	65.3** (50.8)	1020.3 (793.8)	yield/bond/diagonal tension	
T-5-C	14.0	5.750	11.50	30.1	403.1	side split	
T-5-E	14.0	12.500 (9.850)	25.00 (19.70)	65.5** (51.6)	877.2 (691.1)	diagonal tension	
T-6-C	6.0	3.875	7.75	20.3	634.4	side split	
T-6-E	4.0	11.000 (11.000)	22.00 (22.00)	57.6 (57.6)	2700.0 (2700.0)	side split	

*Values contained in parenthesis reflect the state of the epoxy beam when the first crack in the epoxy block occurred.

**Yield stress is approximately 65.5 ksi.

wherein

M = actual bending moment

A_s = tension steel area (0.88 sq. in.), and

jd = distance between centroid of tension steel and line of action of resultant compression forces, also referred to as arm of internal couple.

The value for j was taken as 0.85, based upon the computed values of the transformed cross section (elastic behavior) and at tension failure for a concrete beam with the given test beam parameters listed below:

$$f'_c = 5100 \text{ psi}$$

$$f_y = 60,000 \text{ psi}$$

$$b = 5 \text{ inches}$$

$$d = 6\text{-}1/8 \text{ inches}$$

$$d' = 1\text{-}1/8 \text{ inches}$$

$$A_s = 0.88 \text{ square inches}$$

$$A_s' = 0.44 \text{ square inches}$$

Calculations for determining j are contained in Appendix C.

The calculated bond stress was determined from the following expression:

$$u = \frac{f_s d_b}{4l_s} \quad (3-2)$$

in which

f_s = steel stress as determined above,

d_b = bar diameter, and

l_s = splice length.

CHAPTER IV

DISCUSSION

4.1 Cylinder Test Results

The average splitting tensile strength for the concrete was determined to be 583 psi. The average split-cylinder tensile strength of the epoxy concrete was 1662 psi. In general, the tensile strength of the epoxy concrete was approximately 2.8 times that of the concrete.

The split-cylinder tensile strength of concrete has often been expressed as some constant times the square root of the concrete compressive strength. The relationship between concrete tensile strength and the square root of the concrete compressive strength based upon the average strengths obtained in this investigation is

$$\frac{f'_t}{\sqrt{f'_c}} = 8.17. \quad (4-1)$$

This is slightly higher than the 6.7 value indirectly used in ACI Standard 318-71 (2). It should be noted, however, that the split-cylinder test specimens were 3" x 6" cylinders instead of the more normal 6" x 12".

4.2 Concrete Test Beams

As anticipated, the predominant failure mode for the concrete test beams was side split failure. In each case, the progression toward splitting failure closely followed the normal progression for tension lap splices in a constant moment section as reported by ACI Committee 408 (3). The progressive sequence is as follows:

- (1) Premature flexure cracking usually occurs at each end of the splice.
- (2) Splitting starts from these end cracks and moves toward the center along the reinforcement plane.
- (3) Additional flexure cracks may form between the end cracks and splitting may develop from these flexure cracks also.
- (4) Failure usually occurs with sudden splitting of the remaining 20 to 40 percent of the splice length.

This failure sequence is illustrated by the series of photographs in Figures 13 through 16.

Figures 17 through 20 illustrate the side split failure mode in several of the concrete beams.

In one specimen, some face splitting did occur (Figure 21). The face splitting observed, however,

was not the characteristic splitting that might have been expected for a beam with two lap splices. Rather than two longitudinal cracks over the lapped bars, a single longitudinal crack occurred down the face of the beam over the clear space between the contact splices. The side splitting in the same test beam, T-3-C, is illustrated in Figure 22.

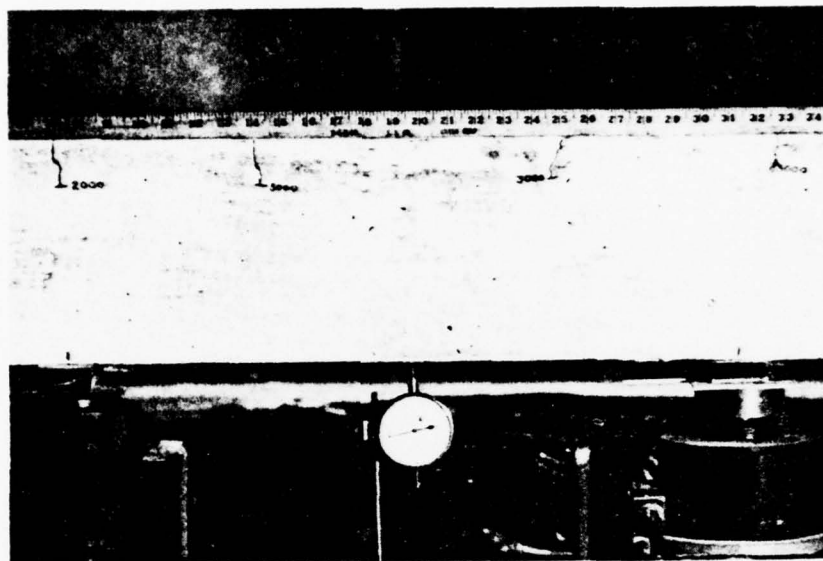

Fig. 13. Beam T-4-C. Splice Length = 12 inches. Load = 3 kpj. Flexure Cracks Develop Near Ends of Splices.



Fig. 14. Beam T-4-C. Load = 5.25 kpj. Horizontal Cracking Along Reinforcement Plane Begins.

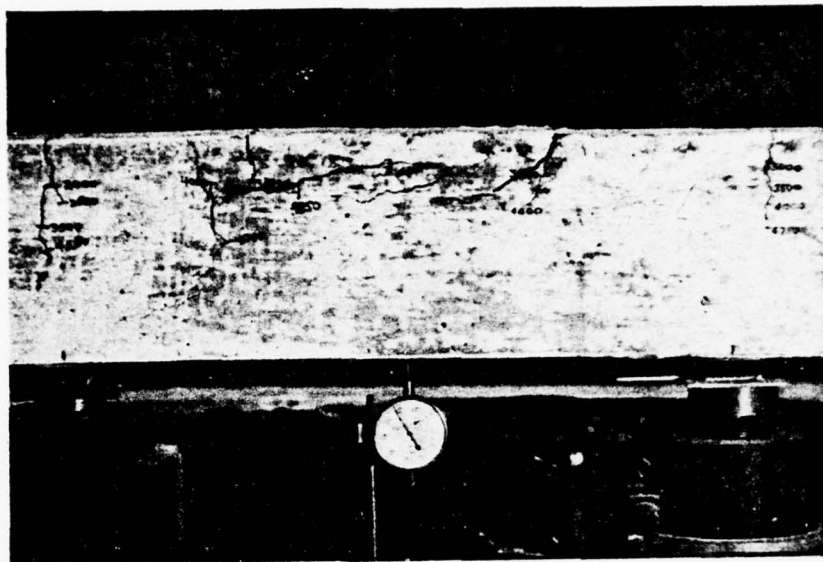

Fig. 15. Beam T-4-C. Load = 5.5 kpj. Side Split Failure Occurs.

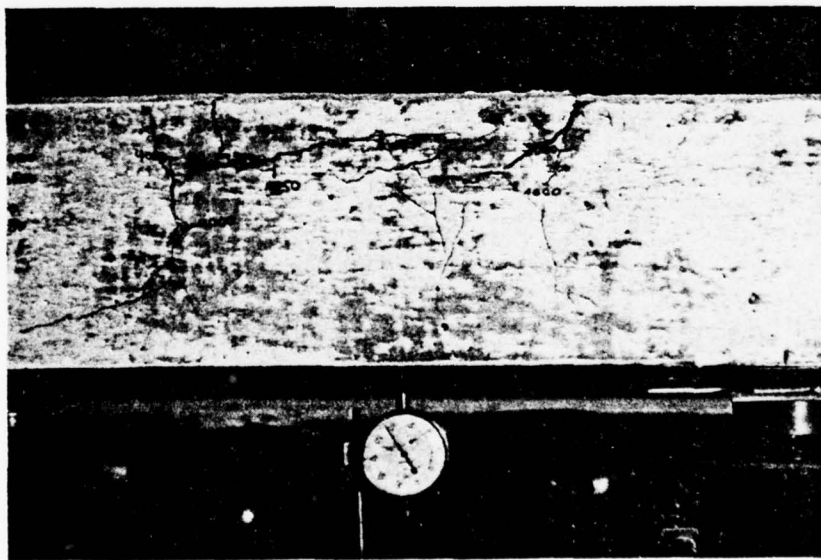

Fig. 16. Beam T-4-C. Load = 5.5 kpj. Close Up view of Side Split Failure.

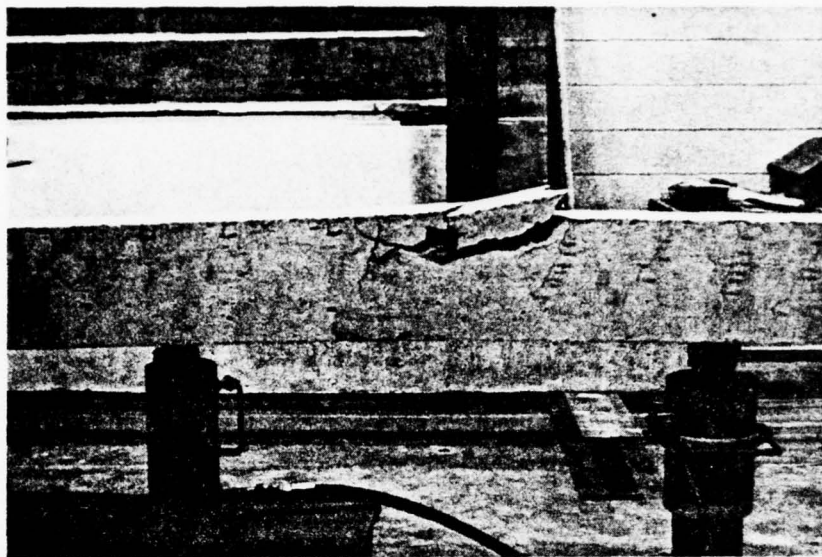

Fig. 17. Side Split Failure of T-1-C. Splice Length = 12 inches. Failure Moment = 12.75 kip-ft.



Fig. 18. Side Split Failure of T-3-C. Splice Length = 16 inches. Failure Moment = 13.0 kip-ft.

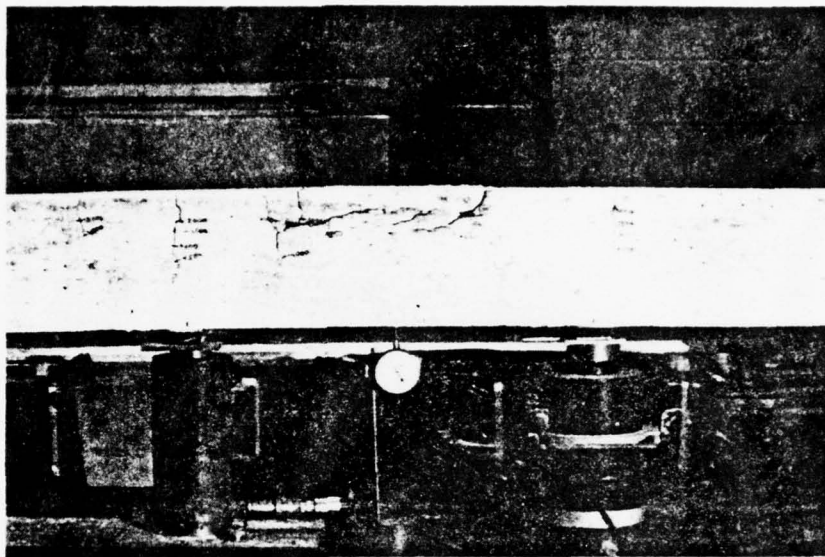

Fig. 19. Side Split Failure of T-4-C. Splice Length = 12 inches. Failure Moment = 11.0 kip-ft.

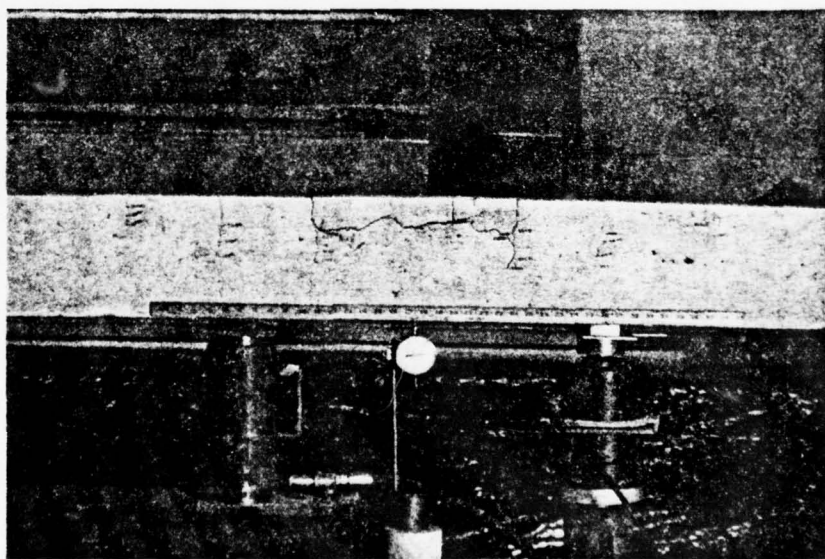

Fig. 20. Side Split Failure of T-5-C. Splice Length = 14 inches. Failure Moment = 11.5 kip-ft.

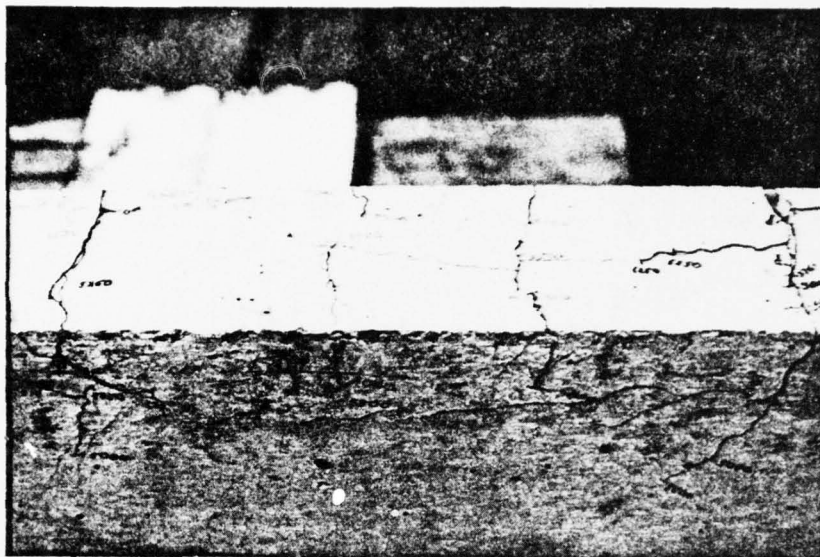

Fig. 21. Face Splitting in Test Beam T-3-C. Splice Length = 16 inches.

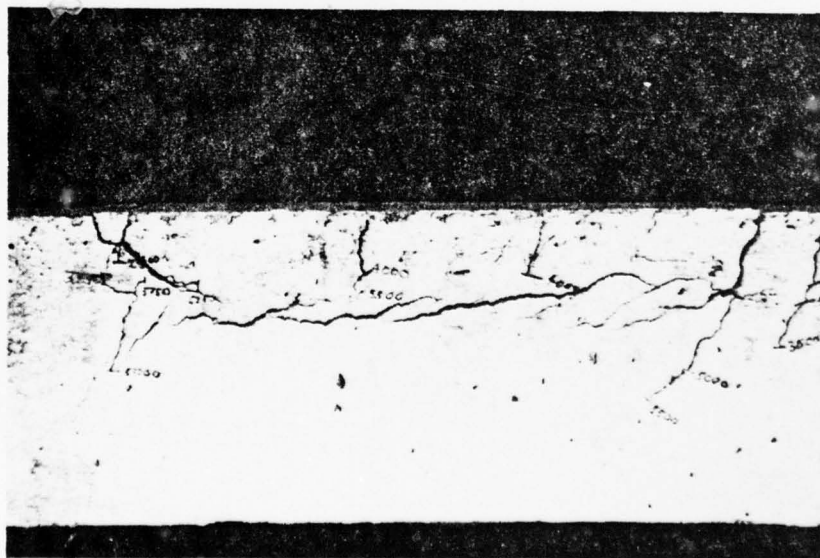

Fig. 22. Side View of Side Split Failure of T-3-C.

From the data obtained on the concrete test beams, the critical lap length required to develop the full tensile capacity of the steel can be predicted. The approach recently proposed by Orangun, Jirsa, and Breen (18) will be used.

By nonlinear regression analysis of test results of 62 beams, Orangun, et al., developed the following best-fit relationship:

$$u^*/\sqrt{f'_c} = 1.22 + 3.23C/d_b + 53.0d_b/\ell_s. \quad (1-7)$$

This equation is plotted in Figure 23 with d_b/ℓ_s as abscissae and $u/\sqrt{f'_c}$ as ordinates for C/d_b taken as 0.5/0.75, the values for the beams of this present study. Values of $u/\sqrt{f'_c}$ and corresponding values of ℓ_s/d_b for the six concrete beams tested in this investigation are plotted as discrete points on the figure. Orangun, et al., simplified the coefficients of their equation to obtain a recommended design equation

$$u_c/\sqrt{f'_c} = 1.2 + 3.0C/d_b + 50.0d_b/\ell_s. \quad (4-2)$$

A plot of this equation appears as the dashed line. Calculated values are tabulated in Table V.

Correlation between test results and both the "best-fit" and the simplified relationships developed by Orangun, Jirsa, and Breen is excellent. It is slightly better for the simplified equation, however.

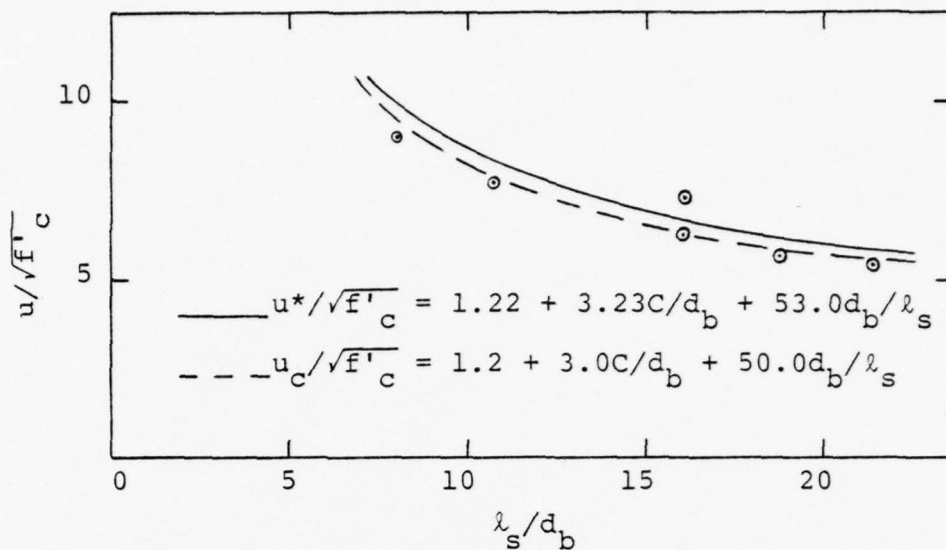

Fig. 23. Variation of $u/\sqrt{f'_c}$ with λ_s/d_b for $C/d_b = 2/3$.

TABLE V

COMPARISON OF CALCULATED BOND STRESS AND TEST VALUES

Test Beam	λ_s (in.)	f_s (test) (ksi)	u_t (test) (psi)	$\sqrt{f'_c}$ (psi)	$u_t/\sqrt{f'_c}$	$u^*/\sqrt{f'_c}$	$u_c/\sqrt{f'_c}$
T-1-C	12	33.4	521.8	5090	7.31	6.70	6.33
T-2-C	8	23.6	553.1	5032	7.80	8.35	7.89
T-3-C	16	34.0	398.4	5353	5.45	5.86	5.54
T-4-C	12	28.8	440.6	5050	6.20	6.70	6.33
T-5-C	14	30.1	403.1	5053	5.67	6.22	5.88
T-6-C	6	20.3	634.4	4957	9.01	10.01	9.45

From the simplified equation, the critical lap length required to develop the full tensile capacity of the reinforcing bars can be determined as shown in the following derivation:

From Eq. 1-3, the unit bond stress at $f_s = f_y$ is

$$u = \frac{f_y d_b}{4\lambda_d}$$

Therefore, dividing both sides by $\sqrt{f'_c}$ gives

$$u/\sqrt{f'_c} = \frac{f_y d_b}{4\lambda_d \sqrt{f'_c}}$$

Equating the right hand side of the equation above to Eq. 4-2 yields

$$\frac{f_y d_b}{4\lambda_d \sqrt{f'_c}} = 1.2 + 3C/d_b + 50d_b/\lambda_d$$

Solving for λ_d produces

$$\lambda_d = \frac{d_b \left[\frac{f_y}{4\sqrt{f'_c}} - 50 \right]}{[1.2 + 3.0C/d_b]} \quad (4-3)$$

If f_y is taken as 60,000 psi, $f'_c = 5100$ psi, $C/d_b = 2/3$, and $d_b = 0.75$, the actual development length required to develop f_y is 37.5 inches from Eq. 4-3.

For design purposes, Orangun, et al., recommend a capacity reduction factor of 0.8 to account for deviations in material properties and dimensional errors.

The design lap length needed for the beams investigated would then be $l_s = 37.5/0.8$ or $l_s = 46-7/8$ inches.

For $f_y = 65,000$ psi, the required development length would be 41.6 inches with a corresponding design splice length of 52.0 inches.

4.3 Epoxy Test Beams

The test results for the epoxy beams are summarized in Table IV along with those of the concrete beam specimens.

Considering the objective of this study, it was unfortunate that failure in the splice zone occurred in only one of the six epoxy beams tested. That failure took place suddenly in test specimen T-6-E which had a lap length of 4 inches. All other specimens failed after yielding of the tensile steel or by bond or diagonal tension failure outside the constant moment region at calculated steel stresses in excess of 57 ksi. Photographs of several epoxy beam failures and pertinent data are presented in Figures 24 through 31.

After the bond failure of test specimen T-1-E, the shear span for subsequent tests was changed from 18 to 24 inches. This change necessitated the use of external stirrups (Figures 32 and 33) for test beams

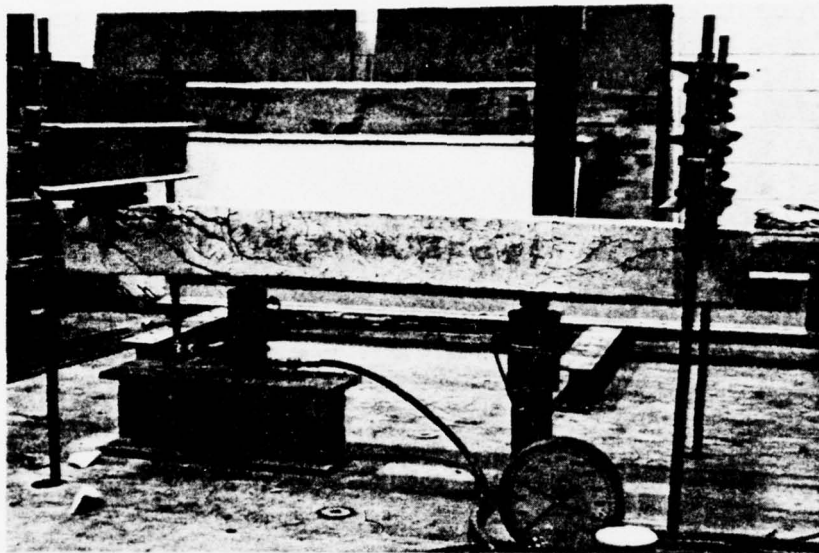

Fig. 24. Bond Failure of T-1-E. Splice Length = 12 inches. Failure Moment = 22.3 kip-ft.

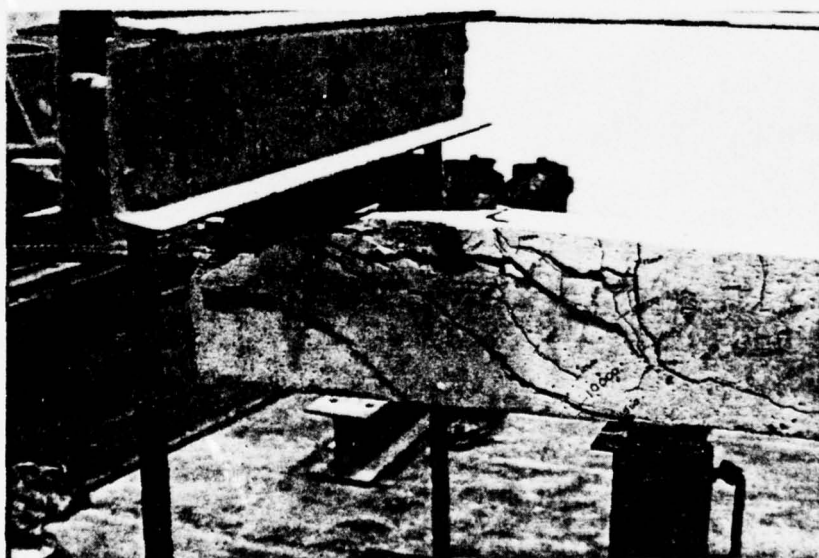

Fig. 25. Close Up of Bond Failure of T-1-E.

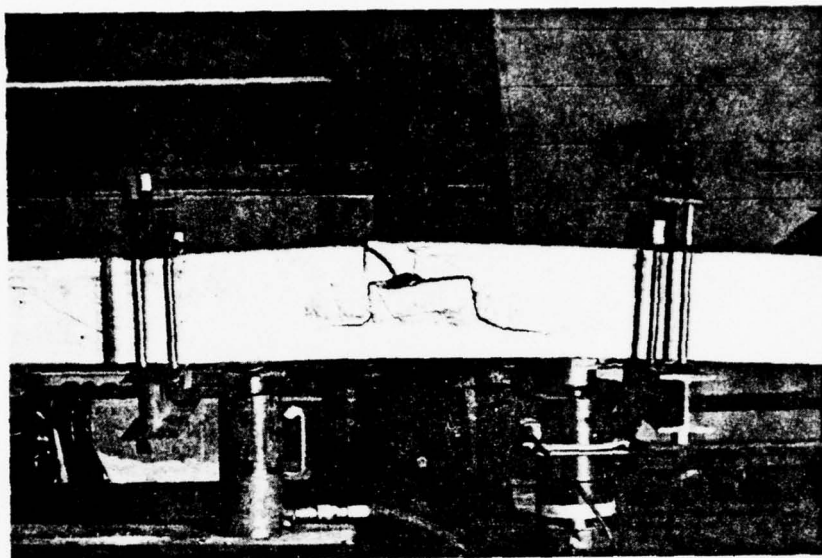

Fig 26. Failure in Test Specimen T-2-E After Yielding of the Tensile Reinforcement. Splice Length = 8 inches.

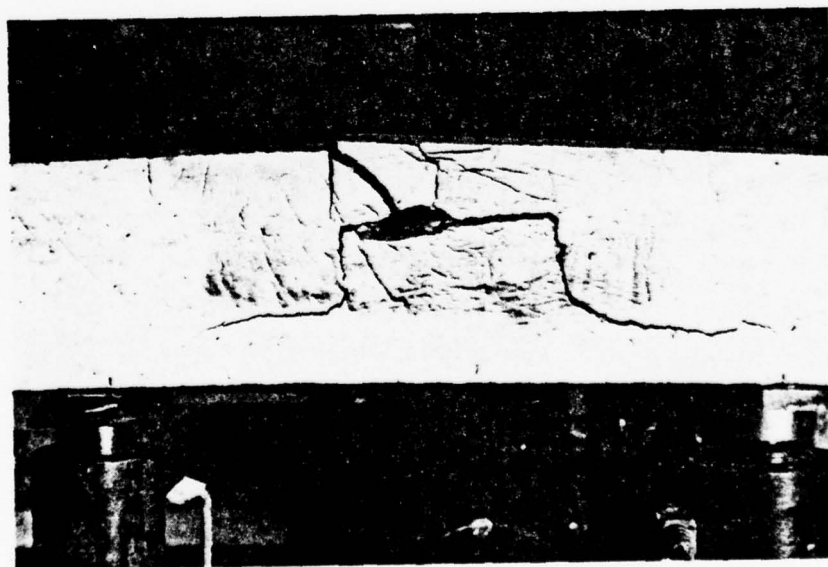

Fig. 27. Close Up of T-2-E at Failure.

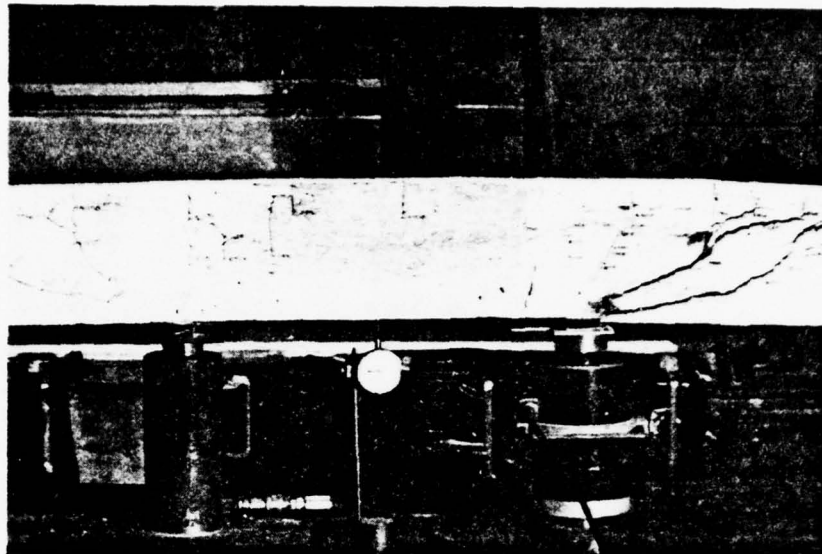

Fig. 28. Bond Failure of T-4-E. Splice Length = 12 inches. Failure Moment = 24.9 kip-ft. Yielding of Tension Steel Was Obvious Prior to Bond Failure.

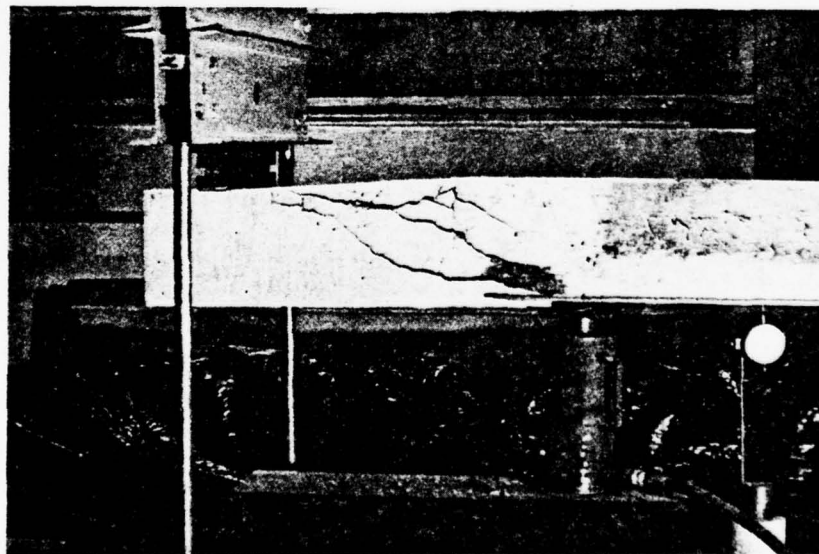

Fig. 29. Diagonal Tension Failure of T-5-E. Splice Length = 14 inches. Failure Moment = 25.0 kip-ft.

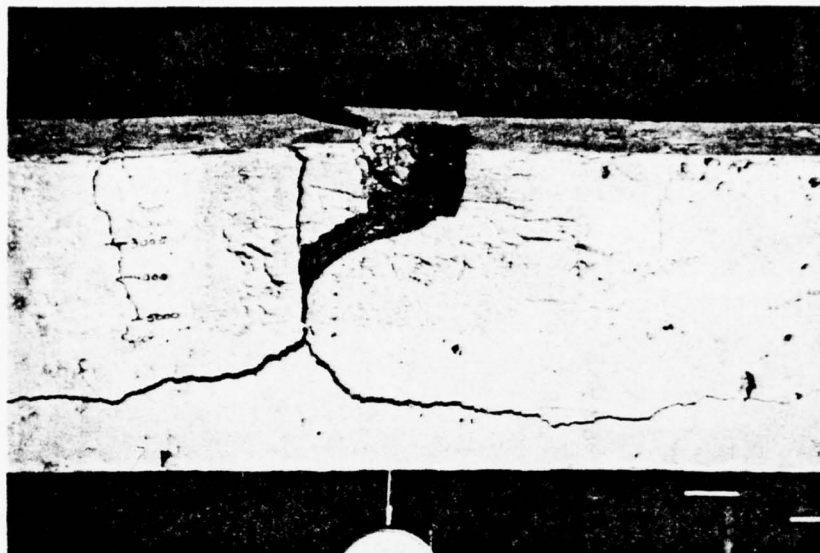

Fig. 30. Side Split Failure of T-6-E. Splice Length = 4 inches. Failure Moment = 22.0 kip-ft.

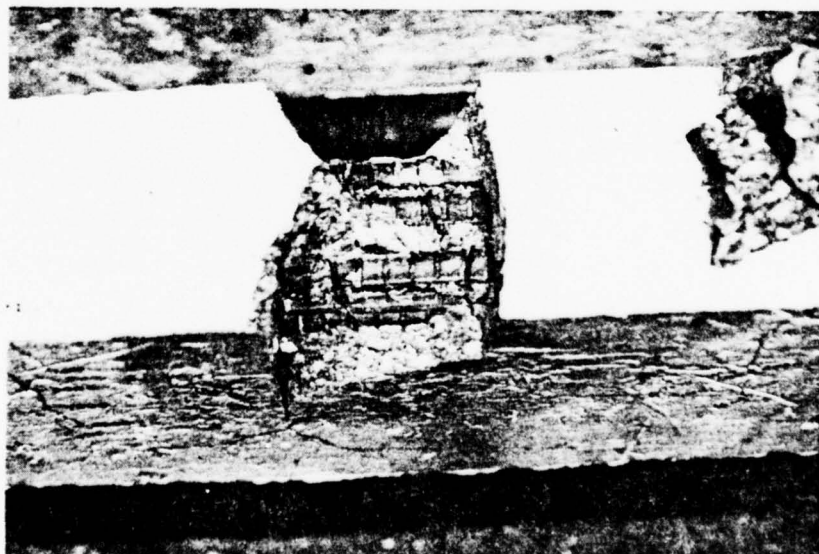

Fig. 31. Top View of T-6-E With Loose Material Removed. Note Ends of Splices.

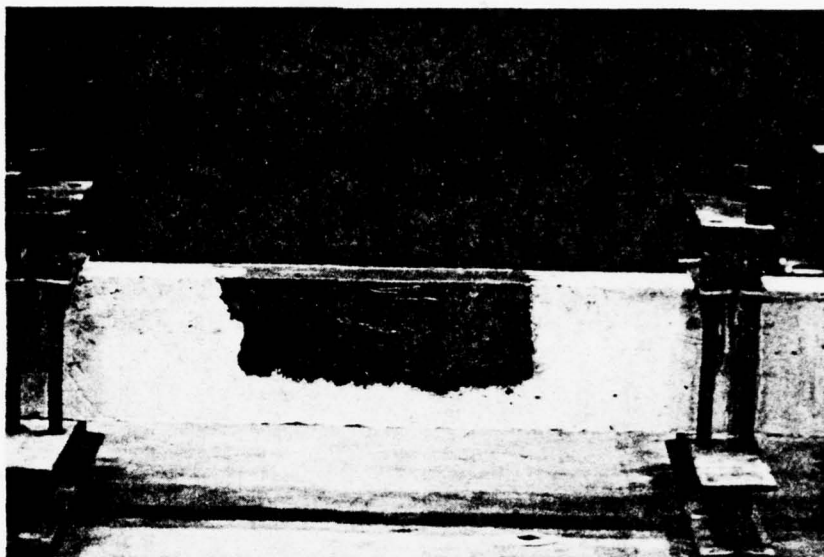

Fig. 32. Close Up of Test Specimen T-2-E Showing External Stirrups Outside Constant Moment Region. Epoxy Concrete Block Is Shown Before Whitewashing.

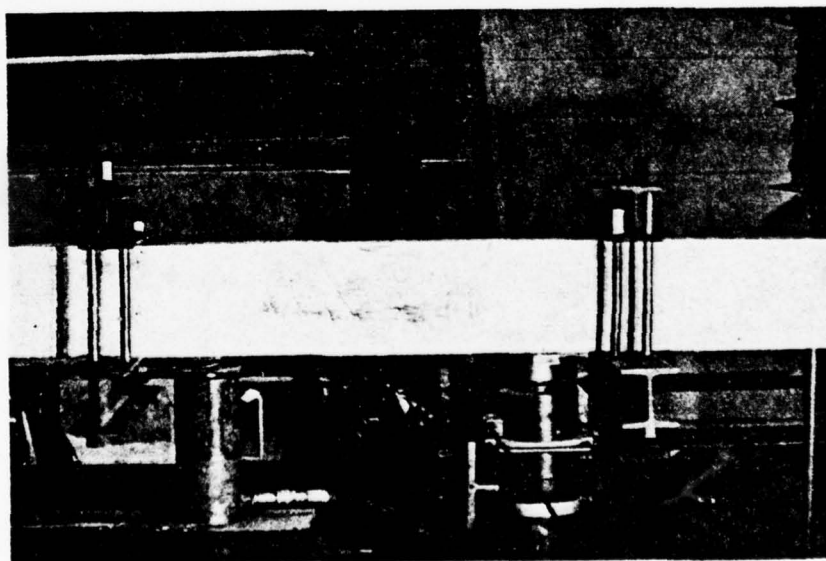

Fig. 33. T-2-E in Test Arrangement.

T-2-E and T-3-E which had already been cast with web reinforcement provided for only an 18-inch shear span. Test specimens T-4-E, T-5-E, and T-6-E, were cast with web reinforcement for the full 24-inch shear span. Consequently, external stirrups were not required for these beams.

From the test data obtained, the lap length required to develop a yield stress of 60 ksi in a #6 bar was determined to be between 4 and 8 inches. Since the calculated steel stress at failure in the 4-inch* splice beam was 57.6 ksi, and since the 8-inch splice beam reached yield stress ($f_y = 65.5$ ksi), the predicted critical lap length for 60 ksi steel would be close to 4 inches. It is the author's estimate that the critical lap length is approximately 4.5 inches.

4.4 Comparison of Concrete and Epoxy Test Results

As can be seen from the test results presented in the preceding sections, the beams which had an epoxy concrete block cast around the tension lap splices exhibited greater strength than the "pure" reinforced concrete beams.

In order to make a valid comparison of relative strengths, the results of Test Series #6 were used.

*The actual splice length measured after failure was 3.8 inches.

For a 4-inch splice, side split failure occurred in the epoxy beam when the calculated stress in the tensile reinforcement was 57.6 ksi. For a 6-inch splice, side split failure in the concrete occurred when f_s (calculated) was 20.3 ksi. The ultimate bond stress for $l_s = 4$ inches and $f'_c = 5100$ psi computed from the simplified equation of Orangun, et al., (Eq. 4-2) is 898 psi. This would develop a steel stress of 19,157 psi in a #6 bar. Based on these figures, the epoxy beam demonstrated 3.01 times the load carrying capacity of a comparable concrete beam with this splice length. This correlates well with the previous comparison of split-cylinder tensile strengths in which the epoxy concrete proved to be approximately 2.8 times as strong in tension as the concrete.

Since none of the other epoxy test beams failed in the splice zone at values of f_s less than f_y , the only obvious inference to be drawn from comparisons with the concrete specimens is that for a given splice length, the epoxy beam's load carrying capacity was much greater than that of the concrete beam.

From the analysis of the concrete test data, the required development length was predicted as 37.5 inches. The design length recommended by Orangun, Jirsa, and Breen in this case would be approximately

47 inches. The critical splice length predicted for the epoxy beam was 4.5 inches. The design length recommended for a beam with an epoxy concrete block cast around the lap splices, as a practical consideration, might be 12 inches. The net savings in steel by using an epoxy concrete block in this instance would be close to six feet per splice. A corresponding savings in design time and construction time is also a real possibility.

CHAPTER V

SUMMARY, CONCLUSIONS, AND RECOMMENDATIONS

5.1 Summary

The objective of this investigation was to compare the relative load-carrying capacity of concrete and epoxy-strengthened beams for varying lengths of reinforcement lap in a constant moment region. To evaluate splice strengths, six series of test beams and companion test cylinders were cast. Concrete compressive strength, concrete and epoxy system tensile strengths, and relative beam strengths were determined for each test series.

All beam specimens were tested over a span of six feet on the University of Colorado structural test floor. Beams were placed in the test arrangement and loaded tension side up to facilitate observation and recording of crack progression. Load was applied by means of two hydraulic jacks placed symmetrically beneath the test beam. Reactions were provided by use of steel double channels placed transversely on the test beams and secured to the test floor with tension tie rods. Roller arrangements were placed between the steel double channels and the tension side of the beam

to permit free rotation of the specimen during testing.

The predominant mode of failure in the concrete test beams was side split failure. The progressive failure of the concrete beams generally began with the formation of flexure cracks over the ends of the splices. From these end cracks, horizontal splitting along the reinforcement plane in the splice zone would develop. If additional flexural cracking occurred in the splice zone, horizontal cracking emanated from these flexure cracks also. Failure usually occurred suddenly with cracking over the remaining 20 to 40 percent of the length of the splice.

Only one of the epoxy-strengthened beams failed in the splice zone with f_s less than f_y in the tension reinforcement. That failure occurred in a test specimen with a lap length of four inches. The remaining five epoxy beams failed by yielding of the tension steel or by bond and diagonal tension outside the constant moment region.

A comparison of test results of the portland cement concrete beams with a recent proposal for prediction of critical lap length was made.

5.2 Conclusions

Based upon the data obtained during this investigation, the following conclusions can be drawn:

(1) The epoxy system used had a tensile strength approximately 2.8 times that of the concrete.

(2) The beams with an epoxy concrete block cast around the lap splices had considerably greater strength than the reinforced concrete beams for equal lengths of lap.

(3) Based on the results from the splice failure which occurred in one epoxy beam, splice strength seems to be proportional to the tensile strength of the material surrounding the splice.

(4) This limited investigation indicated substantial savings in steel when compared to a recent design proposal for conventional concrete recommended by Orangun, Jirsa, and Breen. Additionally, corresponding savings in design time and construction time are viewed as a real possibility.

(5) Test results from concrete beams correlated well with formulas derived by Orangun, Jirsa, and Breen from previous test data.

5.3 Recommendations for Future Study

Based upon the limited scope of this investigation and the encouraging results obtained, the following recommendations for future study are offered.

(1) Use of different epoxy systems in this type of application.

(2) Determination of the effects of bar size, amount of cover, and size of epoxy concrete block on the strength of the lap splice.

(3) Cost effectiveness of the use of epoxy in this application.

REFERENCES

1. ACI Committee 318. Building Code Requirements for Concrete (ACI 318-63). Detroit, American Concrete Institute, 1963, 144 pp.
2. ACI Committee 318. Building Code Requirements for Concrete (ACI 318-71). Detroit, American Concrete Institute, 1971. 78 pp.
3. ACI Committee 408. "Bond Stress--The State of the Art." Journal of the American Concrete Institute. Proceedings, Vol. 63 (November, 1966), pp. 1161-1190.
4. ACI Committee 503. Epoxies With Concrete. Detroit, American Concrete Institute, 1968. 140 pp.
5. _____ . "Use of Epoxy Compounds with Concrete." Journal of the American Concrete Institute. Proceedings, Vol. 70 (September, 1973), pp. 614-645
6. American Society for Testing and Materials. 1975 Annual Book of ASTM Standards, Part 14. Philadelphia, American Society for Testing and Materials, 1971, 690 pp.
7. Chamberlin, S.J. "Spacing of Spliced Bars in Tension Pull-Out Specimens." Journal of the American Concrete Institute. Proceedings, Vol. 49 (December, 1952), pp. 261-274.
8. _____ . "Spacing of Spliced Bars in Beams." Journal of the American Concrete Institute. Proceedings, Vol. 54 (February, 1958), pp. 689-697.
9. Chinn, James and Phil M. Ferguson, J. Neils Thompson. "Lapped Splices in Reinforced Concrete Beams." Journal of the American Concrete Institute. Proceedings, Vol. 52 (October, 1955), pp. 201-213.

10. Concrete Reinforcing Steel Institute and Western Concrete Reinforcing Institute. Manual of Standard Practice. Nineteenth edition. Chicago, Concrete Reinforcing Institute, 1968. 101 pp.
11. Ferguson, Phil M. Reinforced Concrete Fundamentals. Second edition. New York, London, Sydney, John Wiley & Sons, Inc., 1965. 718 pp.
12. Ferguson, Phil M. and Robert D. Turpin and J. Neils Thompson. "Minimum Bar Spacing as a Function of Bond and Shear Strength." Journal of the American Concrete Institute, Proceedings, Vol. 50 (June, 1954), pp. 869-887.
13. Ferguson, Phil M. and J. Neils Thompson. "Development Length of High Strength Reinforcing Bars in Bond." Journal of the American Concrete Institute, Proceedings, Vol. 59 (July, 1962), pp. 887-921.
14. Ferguson, Phil M. and John E. Breen. "Lapped Splices for High Strength Reinforcing Bars, [Part I]." Journal of the American Concrete Institute, Proceedings, Vol. 62 (September, 1965), pp. 1063-1077.
15. _____ . "Development Length for Large High Strength Reinforcing Bars, [Part II]." Supplement to Journal of the American Concrete Institute, Proceedings, Vol. 62 (1965), pp. 1013.
16. Lee, Henry and Kris Neville. Epoxy Resins. New York, Toronto, London, McGraw-Hill Book Company, Inc., 1957. 305 pp.
17. Miklofsky, Haaren A. and Michael J. Gonsior, John J. Santini. Further Studies of Epoxy Bonding Compounds. Washington, Highway Research Board of the Division of Engineering and Industrial Research, National Academy of Sciences, 1965. 117 pp.
18. Orangun, C.O. and J.O. Jirsa, J.E. Breen. "The Strength of Anchored Bars: A Reevaluation of Test Data on Development Length and Splices." Research Report 154-3F, Center for Highway Research, The University of Texas at Austin, January 1975. 78 pp.

19. _____ . "Reevaluation of Test Data on Development Length and Splices." Journal of the American Concrete Institute. Proceedings, Vol. 74 (March, 1977), pp. 115-122.
20. Portland Cement Association. Design and Control of Concrete Mixtures. Skokie, Portland Cement Association, 1968. 121 pp.
21. Skeist, Irving. Epoxy Resins. New York, Reinhold Publishing Corporation, 1958. 293 pp.
22. Wang, Chu-Kia and Charles G. Salmon. Reinforced Concrete Design. Second edition. New York and London, Intext Educational Publishers, 1973. 934 pp.

APPENDIX

APPENDIX A

NOMENCLATURE

- A_b = cross-sectional area of longitudinal steel bar,
inch²
- A_s = area of longitudinal tension reinforcement, inch²
- A_s' = area of longitudinal compression reinforcement,
inch²
- A_{tr} = cross-sectional area of transverse reinforcement
at a given spacing, s , per longitudinal bar,
inch²
- a = depth of equivalent rectangular stress block, inch
- b = width of compression face of member, inch
- C = the smaller of C_b or $(1/2)C_s$
- C_b = clear bottom cover over longitudinal bars, inch
- C_s = clear spacing between adjacent bars, inch
- C_s' = compressive force in compression reinforcement,
lbs. or kips
- C_1 = compressive force in concrete, lbs. or kips
- C_2 = compressive force in compression reinforcement,
lbs. or kips
- d = distance from extreme compression fiber to
centroid of tension reinforcement, inch
- d_b = diameter of longitudinal reinforcement, inch
- d' = distance from extreme compression fiber to
centroid of compression reinforcement, inch

- E_c = modulus of elasticity of concrete, psi
- E_s = modulus of elasticity of steel, psi
- f_{c1} = stress in compression reinforcement, psi
- f'_c = specified compressive strength of concrete, psi
- f_s = stress in the longitudinal tension reinforcement,
psi
- f'_t = splitting tensile strength of concrete, psi
- f_y = specified yield strength of longitudinal
reinforcement, psi
- f_{yt} = yield strength of transverse reinforcement, psi
- j = ratio of distance between compressive and tensile
force to effective depth
- l_c = critical lap length, inch
- l_d = development length, inch
- l_s = splice length, inch
- l = specimen length, foot or inch
- M = moment, ft-kips or inch-lbs
- M_u = ultimate moment, ft-kips or inch-lbs
- n = modular ratio, E_s/E_c
- P = load, lbs or kips
- P_u = ultimate load, lbs or kips
- s = effective spacing of transverse reinforcement,
inch
- T = tension force in tensile reinforcement, lbs or kips
- u = average bond stress, psi
- u_c = calculated average bond stress, psi, using Eq. 4-2

- u_t = average bond stress obtained in tests, psi
- u_u = ultimate bond stress, psi
- u^* = the average ultimate bond stress in splices for beams with constant moment over the splice length
- x = distance from extreme compression fiber to the neutral axis, inch
- V = shear force at the section considered
- ϵ_c = strain in the extreme concrete compression fiber
- ϵ_s = strain in the tensile reinforcement
- ϵ'_s = strain in the compression reinforcement
- β_1 = a factor (0.80 in this investigation)
- ϕ = a capacity reduction factor (0.80 in this investigation)

APPENDIX B

MIX DESIGNS

Concrete Mix Design

Cement: Martin Marietta brand, Type I Portland
Cement

Fine Aggregate: No. 100 to No. 4

Coarse Aggregate: No. 4 to $\frac{1}{2}$ "

Slump: 1" - 3"

Design Strength (f'_c): 4600 psi

Water/cement ratio: 0.41 lbs/lb

Batch yield: 6.3 cubic feet

<u>Material</u>	<u>Proportions by weight</u>	<u>% Absolute Volume</u>
Cement	1.00	15.2
Water	.41	19.5
Fine Agg.	1.75	31.4
Coarse Agg.	1.84	33.9

Results: f'_c = 5089 psi (average)

tensile strength = 583 psi (average)

Epoxy System Mix Design

Slump: <1"

Batch yield: .4 cubic feet

<u>Material</u>	<u>% by weight</u>	<u>% by volume</u>
Part A	9.0	10.75
Part B	7.6	10.75
Fine Agg.	41.7	37.6
Coarse Agg.	41.7	40.9
	100.0	100.0

Results: tensile strength = 1662 psi (average)

Aggregate Blends

Coarse Aggregate:

<u>Sieve size</u>	<u>Mix content (lbs/100 lbs)</u>	<u>% Passing</u>
#4	10	10
3/8 inch	45	55
1/2 inch	45	100

Fine Aggregate:

<u>Sieve size</u>	<u>Mix content (lbs/100 lbs)</u>	<u>% Passing</u>	<u>% Cumulative retained</u>
#4	10	100	0
#8	15	90	10
#16	30	75	25
#30	25	45	55
#50	20 (10)*	20	80
#100	0 (10)*	0 (10)*	100 (90)*
Fineness Modulus:			2.70 (2.60)*

*Denotes a change in the fine aggregate blend for Test Series #5 and #6.

APPENDIX C

SAMPLE CALCULATIONS

Determination of Ultimate Strength of
Concrete Beam Test Specimen

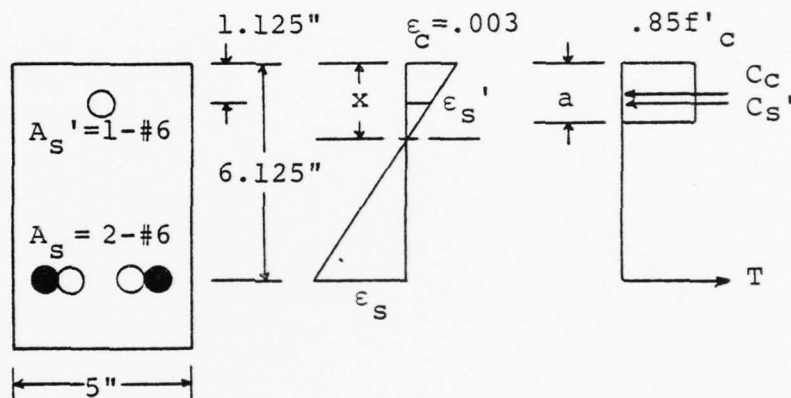

Given:	$f'_c = 5100 \text{ psi}$	$A_s = 0.88 \text{ inch}^2$
	$f_y = 60,000 \text{ psi}$	$A_s' = 0.44 \text{ inch}^2$
	$b = 5 \text{ inch}$	$\beta_1 = 0.80$
	$d = 6-1/8 \text{ inch}$	
	$d' = 1-1/8 \text{ inch}$	

If the compression steel does not yield, the location of the neutral axis can be determined as follows:

$$T = f_y A_s = 60(0.88) = 52.8 \text{ kips}$$

$$C_c = (0.85) f'_c (b) (a) = (0.85) (5.1) (5) (.80x)$$

$$= 17.34x \text{ kips}$$

$$C_s' = [29,000(.003/x)(x-1.125) - (.85)(5.1)](.44)$$

Equating $(C_c + C_s')$ to T and simplifying gives:

$$17.34x^2 - 16.43x - 43.07 = 0$$

The distance from the extreme compression fiber to the neutral axis is

$$x = 2.12 \text{ inch}$$

Therefore,

$$a = \beta_1 x = .80(2.12) = 1.7 \text{ inch}$$

Then

$$C_c = (.85)(5.1)(5)(1.7) = 36.85 \text{ kips}$$

$$\begin{aligned} \epsilon_s' &= (.003)(x - 1.125)/x \\ &= (.003)(2.12 - 1.125)/(2.12) \\ &= .0014 < \epsilon_y = .00207 \end{aligned}$$

$$\begin{aligned} C_s' &= [29(3)(2.12 - 1.125)/(2.12) - (.85)(5.1)].44 \\ &= 16.06 \text{ kips} \end{aligned}$$

$$C_c + C_s' = 36.85 + 16.06 = 52.91 \text{ kips} \approx 52.8 = T$$

$$\begin{aligned} \bar{M}_u &= C_c(6.125 - 1.7/2)/12 + C_s'(6.125 - 1.125)/12 \\ &= \frac{36.85(6.125 - .85)}{12} + \frac{16.06(5)}{12} \\ &= 22.89 \text{ kip-ft} \end{aligned}$$

If the shear span for the test beam is 2 feet, the ultimate load per jack is

$$\underline{P_u = 11.445 \text{ kips}}$$

If the shear span is 1.5 feet, the ultimate load per jack is

$$P_u = 15.26 \text{ kips}$$

The stress in the compression steel when the tension steel yields is

$$f_s' = 16.06 / .44 = 36.5 \text{ ksi} < f_y$$

Determination of "j" for

Test Beam at Tension Failure

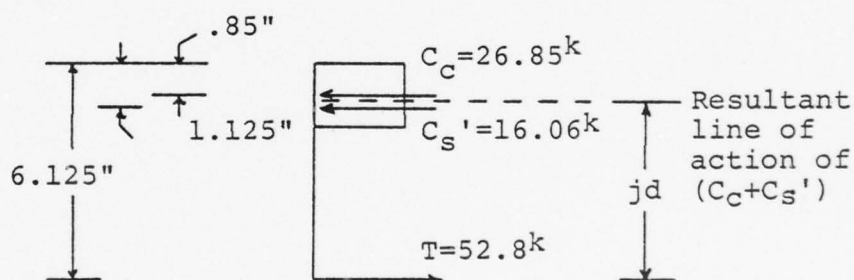

The location of the line of action of the resultant of the compressive forces can be determined by summing moments about the tensile force as shown below:

$$36.85(6.125 - .85) + 16.06(6.125 - 1.125) = (36.85 + 16.06)jd$$

AD-A051 241

COLORADO UNIV BOULDER DEPT OF CIVIL ENVIRONMENTAL AN--ETC F/G 11/2
USE OF EPOXY IN TENSION LAP SPLICES -- IMPACT ON DEVELOPMENT LE--ETC(U)
1977 W E BENEDICT

UNCLASSIFIED

NL

2 OF 2

AD
A051 241



END
DATE
FILMED
4-78
DDC

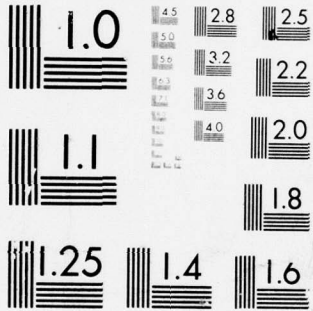

MICROCOPY RESOLUTION TEST CHART
 NATIONAL BUREAU OF STANDARDS-1963-A

Therefore

$$jd = 5.192 \text{ inch}$$

$$j = 5.192/6.125 \text{ or}$$

$$\underline{j = .848}$$

Determination of "j" from Transformed
Cross Section (Elastic Behavior)

An elastic analysis approach can be used since this investigation dealt with short-time loading only.

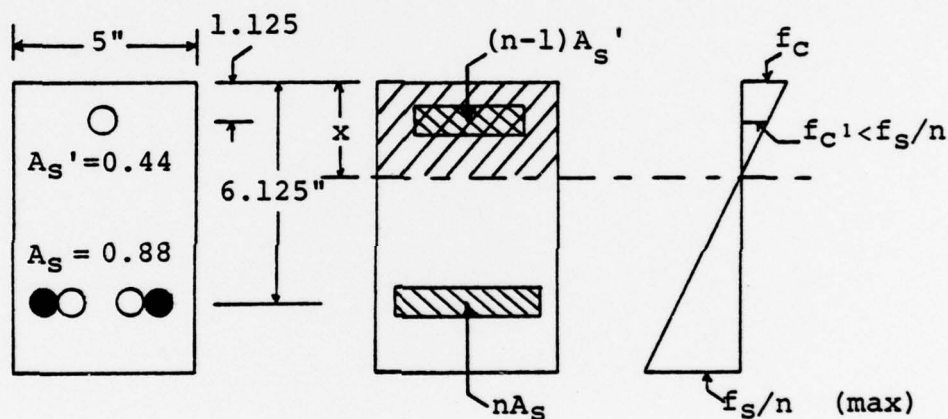

Given: $f'_c = 5100 \text{ psi}$

$$A_s = 0.88 \text{ inch}^2$$

$$f_y = 60,000 \text{ psi}$$

$$A'_s = 0.44 \text{ inch}^2$$

$$b = 5 \text{ inches}$$

$$E_s = 29,000 \text{ ksi}$$

$$d = 6.125 \text{ inches}$$

$$d' = 1.125 \text{ inches}$$

From the current ACI Code, $E_c = 57,000\sqrt{f'_c}$,
allowable $f_s = 24,000 \text{ psi}$, and allowable $f_c = .45f'_c$.
The modular ratio, in this case is $n = 7$.

To determine the location of the centroidal axis,

$$\frac{x}{2}(b)(x) + (n-1)A_s'(x-d') = n(A_s)(d-x)$$

Substituting the appropriate values yields the quadratic given below:

$$x^2 + 3.52x - 16.28 = 0$$

Therefore, $x = 2.64$ inches. From the stress diagram,

$$f_{c1} = (x - 1.125)(.45f'_c)/x = 1317 \text{ psi} < 24,000/7$$

Therefore, the trial transformed section is confirmed.

Then

$$C_1 = \frac{1}{2}f_c(b)(x) = 15.147 \text{ kips}$$

$$C_2 = (n-1)A_s'(f_{c1}) = 3.477 \text{ kips}$$

The location of the line of action of the compressive resultant can be determined as follows:

$$C_1(6.125 - x/3) + C_2(5) = (C_1 + C_2)jd$$

Therefore,

$$jd = 5.2 \text{ inches} \quad \text{and} \quad \underline{j = .849}$$

APPENDIX D

BEAM TEST DATA

The data recorded during testing of the beam specimens is contained in tabular form in this appendix. Load values were determined from the BHL C2P1 load cell and verified by readings from the load dial on the hydraulic pump. Deflection measurements were taken at midspan with a deflection gauge which gave readings as the center of the beam rose due to applied load.

TABLE VI
BEAM TEST DATA

TEST BEAM: T-1-C		
Design Splice Length: 12 inches Shear Span: 18 inches		
Load per jack (lbs)	Mid span Deflection (0.001 in.)	Comments
1,000	not measured	
2,000		
3,000		flexure cracks; directly over loading jacks (top only)
3,250		flexure cracks; vicinity of ends of splices
3,500		continuation of flexural cracks
3,750		
4,000		
4,250		
4,500		
4,750		
5,000		diagonal tension cracks initiated
5,250		
5,500		additional flexural cracks in splice zone
5,750		
6,000		
6,250		
6,500		
6,750		
7,000		
7,250		
7,500		

TEST BEAM: T-1-C (continued)

Load per jack (lbs)	Mid span Deflection (0.001 in.)	Comments
7,750	not measured	
8,000		
8,250		
8,500		FAILURE: side split; no horizontal splitting along plane of reinforcement observed at 8,250 lbs

TEST BEAM: T-1-E

Design Splice Length: 12 inches Shear Span: 18 inches

Load per jack (lbs)	Mid span Deflection (0.001 in.)	Comments
4,000	not measured	cracking at interface of epoxy system block and concrete; flexural cracks over loads
5,000		
6,000		cracks progressing down sides of beams
7,000		diagonal tension cracks begin
8,000		
9,000		
10,000		bond cracking develops from diagonal tension cracks
10,500		
11,000		
11,500		first crack in epoxy system block; flexure crack in center of splice zone; loud noise
12,000		
12,500		
13,000		
13,500		
14,000		
14,500		
14,850		FAILURE: bond/diagonal tension; east end of beam
		Actual Splice Length: 12.08 in.
		Actual Bottom Cover: 1.62 in.

TEST BEAM: T-2-C

Design Splice Length: 8 inches Shear Span: 24 inches

Load per jack (lbs)	Mid span Deflection (0.001 in.)	Comments
1,000	not measured	
2,000		
2,500		flexure cracks over loads
3,000		more flexure cracks; ends of splice
3,250		
3,500		
3,750		
4,000		crack widening particularly over loads
4,250		
4,500		lateral cracking in splice zone; load drops to 4,300 FAILURE; side split; failure occurred while attempting to reload to 4,500

TEST BEAM: T-2-E

Design Splice Length: 8 inches Shear Span: 24 inches

Load per jack (lbs)	Mid span Deflection (0.001 in.)	Comments
1,000	not measured	
2,000		
2,500		flexural cracks in concrete
3,000		
3,500		
4,000		
4,500		
5,000		one inch diagonal tension crack
5,500		
6,000		
6,250		
6,500		cracks widening
6,750		
7,000		
7,250		
7,500		
7,750		
8,000		
8,250		
8,500		
8,750		
9,000		cracking at epoxy system-concrete interface; cracks propogating down sides of beam
9,250		diagonal tension cracks developing
9,500		
9,750		bond splitting begins from diagonal tension cracks
10,050		first crack in epoxy system block; crack in center of splice zone; load drop to 9800

TEST BEAM: T-2-E (continued)

Load per jack (lbs)	Mid span Deflection (0.001 in.)	Comments
10,250	not measured	
10,500		
10,750		diagonal tension cracks continue to develop
11,000		
11,100		
11,200		
11,300		
11,400		diagonal tension-bond crack network enlarging
11,600		
11,700		
12,000		diagonal tension cracks widening
12,250		
12,500		
12,750		second epoxy system crack; east end of splice
13,000		new diagonal tension cracks in concrete
13,250		yield obvious; hard to reach 13,250; repeated pumping of hydraulic pump at 13,175; load drops to 12,650
13,400		third crack in epoxy at 12,700 over west end of splice; obvious yielding at approx. 13,150 range; loading stopped
		Actual Splice Length: 7.80 in.
		Actual Bottom Cover: 1.74 in.

TEST BEAM: T-3-C

Design Splice Length: 16 inches Shear Span: 24 inches

Load per jack (lbs)	Mid span Deflection (0.001 in.)	Comments
2,000	not measured	flexure cracks over loads; cracks continue down sides 1 inch-2 inches
2,500		flexure cracks over ends of splice
3,000		
3,250		
3,500		flexure cracks in center of splice zone
3,750		
4,000		
4,250		
4,500		
4,750		
5,000		
5,250		face splitting between two splices
5,500		horizontal cracking in splice zone along reinforcement plane
6,000		diagonal tension cracks developing
6,250		additional horizontal cracking in splice zone
6,500		FAILURE; side split; face splitting evident for approx. 70% of splice length

TEST BEAM: T-3-E

Design Splice Length: 16 inches Shear Span: 24 inches

Load per jack (lbs)	Mid span Deflection (0.001 in.)	Comments
2,000	not measured	
4,000		flexure cracks over loads
5,000		
6,500		
7,500		
8,500		
9,500		extensive diagonal tension crack network developing
10,000		
10,500		
11,000		
11,500		first crack in epoxy system block; crack near east end of splice
12,000		bond cracking develops
12,400		second crack in epoxy system block; crack inside west end of splice
12,500		
12,975		FAILURE; yielding of steel obvious; test stopped
		Actual Splice Length: 16.13 in.
		Actual Bottom Cover: 1.58 in.

TEST BEAM: T-4-C

Design Splice Length: 12 inches Shear Span: 24 inches

Load per jack (lbs)	Mid span Deflection (0.001 in.)	Comments
1,000		
2,000	.004	flexure cracks over load
3,000	.061	
3,500	.188	additional flexure cracks in splice zone
4,000	.215	
4,250	.228	
4,500	.242	cracks widening
4,750	.255	
5,000	.261	
5,250	.285	horizontal cracking in splice zone
5,500	.335	FAILURE; side split; load drops to 1,100
		Actual Splice Length: 12.05 in.
		Actual Bottom Cover: 1.62 in.

TEST BEAM: T-4-E

Design Splice Length: 12 inches Shear Span: 24 inches

Load per jack (lbs)	Mid span Deflection (0.001 in.)	Comments
2,000	.083	flexure cracks over loads
3,000		flexure cracks extend down sides of beam
4,000	.173	
5,000	.216	
5,500	.238	flexure crack at interface
6,000	.265	
6,500	.288	
7,000	.310	
7,500	.333	diagonal tension cracks begin to develop
8,000	.358	
8,500	.384	bond cracking begins
9,000	.388	
9,500	.406	bond cracking continues to develop
9,700	*	first crack in epoxy system block; flexure crack in center of splice zone
10,000	.408	
10,500	.410	
11,000	.415	interconnection of bond cracking
11,500	.415	
11,900	.419	second crack in epoxy block; flexure and side crack at east end of splice
12,000	.420	
12,450	.700	obvious yield at approx. 12,400; load drops to 10,550; reloaded to 12,350 followed by drop off again to 10,100

TEST BEAM: T-4-E (continued)

Design Splice Length: 12 inches Shear Span: 24 inches

Load per jack (lbs)	Mid span Deflection (0.001 in.)	Comments
12,450 (cont.)		FAILURE; bond and diagonal tension; west end of beam
		Actual Splice Length: 12.10 in.
		Actual Bottom Cover: 1.65 in.

*With first crack in epoxy system block, deflection guage apparently jammed; readings from this point on were not correct. Deficiency not observed until after 12,000 lbs. applied.

TEST BEAM: T-5-C

Design Splice Length: 14 inches Shear Span: 24 inches

Load per jack (lbs)	Mid span Deflection (0.001 in.)	Comments
2,000	.206	flexure cracks over loads
3,000	.253	flexure cracks over ends of splice
3,500	.278	horizontal cracking initiated
4,000	.298	
4,500	.318	
5,000	.340	
5,500	.362	
5,750	.376→.445	FAILURE; side split

Actual Splice Length:
14.20 in.

Actual Bottom Cover:
1.60 in.

TEST BEAM: T-5-E

Design Splice Length: 14 inches Shear Span: 24 inches

Load per jack (lbs)	Mid span Deflection (0.001 in.)	Comments
2,000	.084	
3,000	.124	flexure cracks over loads
4,000	.163	
5,000	.201	
6,000	.240	
7,000	.279	
8,000	.319	
9,000	.362	
9,500	.390	
9,850		first crack in epoxy system block
10,000	.428	
10,500	.455	
11,000	.480	second crack in epoxy system block; flexure crack in center of splice zone
11,500	.480*	
12,000	.480*	
12,500	.639→.731	FAILURE; diagonal tension; east end of beam
		Actual Splice Length: 14.25 in.
		Actual Bottom Cover: 1.64 in.

*Deflection guage stuck.

TEST BEAM: T-6-C

Design Splice Length: 6 inches Shear Span: 24 inches

Load per jack (lbs)	Mid span Deflection (0.001 in.)	Comments
2,000	.180	flexure cracking begins
2,500	.209	
3,000	.234	flexure cracks at end of splice zone
3,250	.251	
3,500	.265	
3,750	.280	
3,875	.355	FAILURE; side split; no obvious horizontal cracking prior to failure
		Actual Splice Length: 5.98 in.
		Actual Bottom Cover: 1.64 in.

TEST BEAM: T-6-E

Design Splice Length: 4 inches Shear Span: 24 inches

Load per jack (lbs)	Mid span Deflection (0.001 in.)	Comments
2,000	.128	
3,000	.276	flexure cracks over load
4,000	.324	flexure cracks at interface
5,000	.373	
5,500	.399	
6,000	.421	
6,500	.443	
7,000	.469	
7,500	.497	
8,000	.522	
8,500	.547	
9,000	.575	
9,500	.604	
10,000	.633	
10,500	.677	
11,000		FAILURE; side split; no indication of failure prior to its occurrence; loud noise upon failure; chunks of epoxy system over splice thrown approx. 1 ft. in air; catastrophic failure; failure occurred after load applied and held for approx. 30 seconds
		Actual Splice Length: 3.80 in.
		Actual Bottom Cover: 1.68 in.