

AD-A051 319

KAMAN AEROSPACE CORP BLOOMFIELD CONN
ADVANCED DEVELOPMENT OF A HELICOPTER ROTOR ISOLATION SYSTEM FOR--ETC(U)
DEC 77 R JONES
R-1396-2

F/G 1/3

DAAJ02-72-C-0082

UNCLASSIFIED

USAAMRDL-TR-77-238

NL

1 OF 3
AD
A051319





AD A 051319

USAAMRDL-TR-77-23B

12
B.S.



**ADVANCED DEVELOPMENT OF A HELICOPTER ROTOR ISOLATION
SYSTEM FOR IMPROVED RELIABILITY**

Volume II - Detailed Report

**Kaman Aerospace Corporation
Bloomfield, Connecticut 06002**

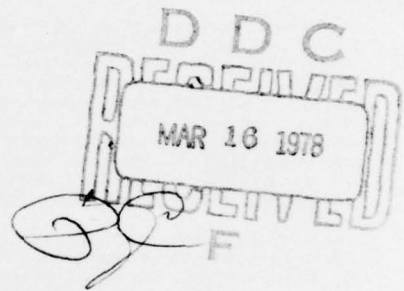

JUL FILE COPY

December 1977

Final Report for Period June 1972 - February 1976

Approved for public release;
distribution unlimited.

**Prepared for
APPLIED TECHNOLOGY LABORATORY
U. S. ARMY RESEARCH AND TECHNOLOGY LABORATORIES (AVRADCOM)
Fort Eustis, Va. 23604**

APPLIED TECHNOLOGY LABORATORY POSITION STATEMENT*

This report documents the culmination of a U.S. Army Air Mobility Research and Development Laboratory (USAAMRDL) search for an effective, lightweight, practical helicopter rotor isolation system. At the outset of this program, the challenge was to successfully flight-demonstrate an isolation system capable of isolating a helicopter's fuselage from vertical and inplane rotor excitation, while being sufficiently light in weight, small in size, and mechanically simple to warrant use in current or proposed new helicopters. This search, some ten years in duration, consisted of a series of investigations wherein consideration was given to both passive and active isolation concepts. For these reasons, it was deemed appropriate that USAAMRDL provide a program review to accompany this report. Your attention is invited to this program review which provides a "thumb-nail" sketch of these USAAMRDL-sponsored pursuits together with some observations regarding related corporate research and development activities within the helicopter industry. The results of this concluding effort are in two volumes: Volume I being a Summary Report; and Volume II details of the analyses and tests of this developmental program.

For many years, the vibration specification to which helicopters had been designed was MIL-H-8501A. A related specification, MIL-S-8698, "required" that suitable antivibration provisions be used in order for the developed helicopter to comply with MIL-H-8501. This had little meaning, for a viable isolation system concept did not exist. Invariably, for military helicopters, a Model Specification was negotiated between the user and the developer providing for a relaxed specification. The resultant deleterious effects of vibration are well documented.

In this developmental program, an isolation system employing the Kaman Dynamic Antiresonant Vibration Isolator (DAVI) was flight test demonstrated on an Army UH-1H helicopter. These results, as well as those by Bell and Boeing-Vertol, discussed in the program review, were most successful. The DAVI-modified UH-1H is estimated to save \$50 per flight-hour in parts and labor. If 1,000 UH-1's were retrofitted to achieve lower costs associated with volume production, the total cost of retrofitting is estimated to be \$7,000,000, whereas an annual savings of \$12,000,000 is forecast. Army development and implementation of a plan to retrofit its UH-1H fleet is recommended. The optimized antiresonant isolation systems developed by Bell and Boeing-Vertol for the Model 206A and BO-105, respectively, yield vibration levels below the more stringent requirements of the UTTAS and AAH. It is evident that antiresonant rotor isolation has considerable potential for future military and commercial helicopters. Isolation system performance, particularly weight penalty, will be even better if it is an integral part of the helicopter's development.

These combined Army-industry results should mark the beginning of a new era - an era wherein the Army and industry have matured so that rotor isolation can be proposed as an integral part of any new helicopter to be developed, confident that such a proposal will no longer be viewed as a sign of weakness or inability to design and deliver, without some form of a "crutch," a helicopter satisfying its vibration requirements. Instead, it is prudent recognition that today's helicopters experience long costly "cut and try" developmental programs to comply with challenging design specifications, and rotor isolation is recognized as a practical solution to the vibration challenge.

This ten-year program was conducted under the technical cognizance of Joseph H. McGarvey, Military Operations Technology Division.

*On 1 September 1977, after this report had been prepared, the name of this organization was changed from Eustis Directorate, U.S. Army Air Mobility Research and Development Laboratory to Applied Technology Laboratory, U. S. Army Research and Technology Laboratories (AVRADCOM).

DISCLAIMERS

The findings in this report are not to be construed as an official Department of the Army position unless so designated by other authorized documents.

When Government drawings, specifications, or other data are used for any purpose other than in connection with a definitely related Government procurement operation, the United States Government thereby incurs no responsibility nor any obligation whatsoever; and the fact that the Government may have formulated, furnished, or in any way supplied the said drawings, specifications, or other data is not to be regarded by implication or otherwise as in any manner licensing the holder or any other person or corporation, or conveying any rights or permission, to manufacture, use, or sell any patented invention that may in any way be related thereto.

Trade names cited in this report do not constitute an official endorsement or approval of the use of such commercial hardware or software.

DISPOSITION INSTRUCTIONS

Destroy this report when no longer needed. Do not return it to the originator.

UNCLASSIFIED

SECURITY CLASSIFICATION OF THIS PAGE (When Data Entered)

REPORT DOCUMENTATION PAGE		READ INSTRUCTIONS BEFORE COMPLETING FORM
1. REPORT NUMBER USAAMRDL-TR-77-23B	2. GOVT ACCESSION NO.	3. RECIPIENT'S CATALOG NUMBER
4. TITLE (and Subtitle) ADVANCED DEVELOPMENT OF A HELICOPTER ROTOR ISOLATION SYSTEM FOR IMPROVED RELIABILITY, VOLUME II, DETAILED REPORT.		5. TYPE OF REPORT & PERIOD COVERED Final Report - 6/72 to 2/76
7. AUTHOR(s) Robert Jones		6. PERFORMING ORG. REPORT NUMBER R-1396-2
9. PERFORMING ORGANIZATION NAME AND ADDRESS Kaman Aerospace Corporation Bloomfield, Connecticut 06002		8. CONTRACT OR GRANT NUMBER(s) DAAJ02-72-C-0082
11. CONTROLLING OFFICE NAME AND ADDRESS Applied Technology Laboratory, U. S. Army Research and Technology Laboratories (AVRADCOM) Fort Eustis, Virginia 23604		10. PROGRAM ELEMENT, PROJECT, TASK AREA & WORK UNIT NUMBERS 63204A 1F163204DB38/00 009 EK
14. MONITORING AGENCY NAME & ADDRESS (if different from Controlling Office) Final rept. Jun 72 - Feb 76		12. REPORT DATE December 1977
16. DISTRIBUTION STATEMENT (of this Report) Approved for public release; distribution unlimited.		13. NUMBER OF PAGES 251
17. DISTRIBUTION STATEMENT (of the abstract entered in Block 20, if different from Report)		15. SECURITY CLASS. (of this report) Unclassified
18. SUPPLEMENTARY NOTES Volume II of a two-volume report		15a. DECLASSIFICATION/DOWNGRADING SCHEDULE
19. KEY WORDS (Continue on reverse side if necessary and identify by block number)		
Rotor Isolation Helicopter Isolation Isolation	Vibration Isolation Antiresonant Isolation Reliability	Maintainability Vibration
20. ABSTRACT (Continue on reverse side if necessary and identify by block number) This report includes the results of the analytical and experimental phases of a helicopter rotor isolation reliability and maintainability (R&M) program on a UH-1 helicopter, which was modified through the addition of a Dynamic Antiresonant Vibration Isolator (DAVI). The final flight test phase demonstrated that the DAVI-modified vehicle had substantially lower vibration levels than the standard vehicle. Vertically,		

DDC
MAR 16 1978
RESOLVED
F

UNCLASSIFIED

SECURITY CLASSIFICATION OF THIS PAGE (When Data Entered)

404 362 AB

UNCLASSIFIED

SECURITY CLASSIFICATION OF THIS PAGE(When Data Entered)

20 (Continued)

the two-per-rev vibration level was reduced to less than one-fifth that of the standard vehicle through the transition speed range and less than one-half at high speeds. An R&M analysis indicated the Army could realize an annual cost savings of approximately \$12,000,000 if 1000 Army UH-1Hs were equipped with DAVI isolation systems. This savings is predicated on the following assumptions: (1) vibration-induced failures will be reduced in proportion to the vibration reduction afforded by the DAVI isolation system; and (2) the UH-1Hs are utilized at the rate of 20 flight-hours per month.

The reduction of the vibration level was achieved with an experimental DAVI isolation system weighing 2.31 percent of the 6600-pound design gross weight. Further refinements of this isolated system could reduce the weight to 1.27 percent of the design gross weight. For vehicles with higher predominant excitation frequencies than 10.8 Hertz for the UH-1H, the weight would be even less.

In the analytical phase, a dynamic analysis was done to determine the proper spring rates of the DAVI system to retain the same mounting points as the standard UH-1 isolation system and to retain dynamic characteristics and flying qualities similar to those of the UH-1H helicopter. Both static and dynamic stress analyses have shown that the DAVI and the structural modifications have adequate margins of safety and infinite life.

Component and system testing was done to substantiate the DAVI-isolated vehicle for flight. Component testing was done early in the program to determine the feasibility of the mechanical pivots and the elastomer selected for the design of the DAVI. System testing included a ground vibration survey of both the DAVI- and the standard-isolated vehicles, a proof test of the DAVI-modified vehicle, and a fatigue test of the DAVI isolation system.

The ground vibration survey showed that the DAVI-isolated system should give a substantial reduction in vibration as compared to the standard UH-1H helicopter. The proof tests showed that the DAVI-modified helicopter could withstand the 125 percent of limit load without failure or permanent set. A 100-hour fatigue test was completed on the DAVI system with no failure. This fatigue test was for 1.5 times the vibratory hub loads expected in flight.

Analysis of the results shows that the DAVI system has dynamic characteristics similar to the standard UH-1 helicopter and that the relative motion between fuselage and transmission is small. The angular misalignment of the engine driveshaft coupling is well within the allowable misalignment criteria.

UNCLASSIFIED

SECURITY CLASSIFICATION OF THIS PAGE(When Data Entered)

PREFACE

This program for flight testing a modified UH-1H helicopter with the Dynamic Antiresonant Vibration Isolator (DAVI) was performed by Kaman Aerospace Corporation, Division of Kaman Corporation, Bloomfield, Connecticut, under Contract No. DAAJ02-72-C-0082, for the U. S. Army Air Mobility Research and Development Laboratory, Eustis Directorate, Fort Eustis, Virginia.

The program was conducted under the technical direction of Mr. J. McGarvey, Military Operations Technology Division, USAAMRDL. At Kaman, Mr. H. Howes was Program Manager and Mr. R. Jones was Technical Monitor. Messrs J. Rembock and H. Cooke were responsible for the design and Mr. M. Tarricone for the structural analysis. In the test phases, Mr. E. Luff was responsible for the ground tests and Mr. F. Bill for the flight test phase. This testing was done under the supervision of Mr. A. D. Rita, Chief Flight Test Engineer.

Special acknowledgment is given to Bell Helicopter Corporation for their cooperation in furnishing reports, entering into discussions and giving recommendations for the design of the modified control system and of the magnitude of the main-rotor forces expected in flight.

TABLE OF CONTENTS

PREFACE 3

LIST OF ILLUSTRATIONS 8

LIST OF TABLES 14

ROTOR ISOLATION - USAAMRDL PROGRAM REVIEW 17

FLIGHT TEST 33

 CONFIGURATIONS 33

 CONDITIONS 37

 INSTRUMENTATION 39

 RESULTS 48

 One-Per-Rev Airframe Response 48

 Two-Per-Rev Airframe Response 57

 Four-Per-Rev Airframe Response 72

 Transmission Response 80

 Engine Response 86

 Relative Deflection/Coupling Misalignment 88

 RPM Sensitivity 96

 Rotor Blade Stresses 96

 Blade Out-of-Track 101

 Main Rotor Change 103

ISOLATION SYSTEM DESCRIPTION 113

 DESIGN PHILOSOPHY 113

 STANDARD UH-1H ISOLATION SYSTEM 115

 DAVI ISOLATION SYSTEM 115

 COMPARATIVE ANALYTICAL RESULTS 116

DESIGN 119

 CRITERIA 119

 Fuselage Structural Modification 119

 DAVI Isolators 120

 Control System 120

ACCESSION for	
NTIS	Write Section <input checked="" type="checkbox"/>
DDC	Buff Section <input type="checkbox"/>
UNANNOUNCED	<input type="checkbox"/>
JUSTIFICATION	
BY	
DISTRIBUTION/AVAILABILITY CODES	
Dist.	SPECIAL
A	

GENERAL ISOLATION SYSTEM DESCRIPTION	120
Standard UH-1H Isolation System	120
DAVI Isolation System	120
Transmission Installation	131
Description, Transmission-Mount DAVI	131
Description, Lift-Link DAVI	134
CONTROL SYSTEM DESCRIPTION	136
Standard UH-1H Control System	136
DAVI-Modified Control System	137
ANALYSIS	144
STRUCTURAL ANALYSIS	144
Loads Analysis	144
Static Structural Analyses	150
DAVI Vibratory Loads	150
Fatigue Analysis	150
FLYING QUALITIES ANALYSIS	161
OPERATING LIMITS OF THE DAVI-MODIFIED UH-1H	168
DAVI Travel Requirements	168
Flight Conditions	169
Hover - Collective Pull-Up Conditions	169
Trimmed Level Flight, Forward Speed Conditions	173
Trimmed Constant Bank Angle Turn Conditions	173
DAVI Deflection/Coupling Misalignment	177
GROUND TESTS	180
COMPONENT TESTS	180
Pivot Test	180
Lift-Link Tubular Mount	183
DAVI Tuning and Spring Rate Tests	183
SYSTEM TESTS	188
Endurance Test	188
Proof Test	195
Ground Vibration Survey	209
SYSTEM ANALYSES	221
PREDICTED VIBRATORY RESPONSES	221

MECHANICAL STABILITY	223
ROTOR-ENGINE COMPATIBILITY	228
RELIABILITY ANALYSIS	230
COST-EFFECTIVENESS	239
WEIGHT	245
CONCLUSIONS	247
RECOMMENDATIONS	248
REFERENCES	249

LIST OF ILLUSTRATIONS

<u>Figure</u>		<u>Page</u>
1	Two-Bladed Case.	21
2	Four-Bladed Case	21
3	Isolation vs Frequency Ratio	22
4	Early Version of Bell's Focused Pylon/Nodal Beam Isolation System.	26
5	Recent Version of Bell's Focused Pylon/Nodal Beam Isolation System.	26
6	Jet Ranger Flight Test Results	27
7	B0-105 Isolation System.	29
8	B0-105 Vibration Levels.	29
9	UH-1H Helicopter, Serial Number 66-1093.	34
10	Schematic of the Standard UH-1H Isolation System	35
11	Schematic of the UH-1H DAVI Isolation System	36
12	Accelerometer Locations.	42
13	Linear Potentiometer Locations - Main Transmission Mount Displacement.	43
14	Strain Gage Locations - Lower Transmission Support Plate Assembly	44
15	Accelerometer Installation - Engine.	45
16	Strain Gage Installation - Rotor Blades and Shaft.	46
17	Position Transducers - Pilot's and Copilot's Controls	47
18	One-Per-Rev Vertical Response of the 8250- Pound UH-1H Helicopter	49

LIST OF ILLUSTRATIONS (Continued)

<u>Figure</u>		<u>Page</u>
19	One-Per-Rev Vertical Response of the 9500-Pound UH-1H Helicopter.	50
20	One-Per-Rev Lateral Response of the 8250-Pound UH-1H Helicopter.	51
21	One-Per-Rev Lateral Response of the 9500-Pound UH-1H Helicopter.	52
22	One-Per-Rev Longitudinal Response of the 8250-Pound UH-1H Helicopter.	53
23	One-Per-Rev Longitudinal Response of the 9500-Pound UH-1H Helicopter.	54
24	One-Per-Rev Vertical Effectivity.	55
25	One-Per-Rev Lateral Effectivity	56
26	Two-Per-Rev Vertical Response of the 8250-Pound UH-1H Helicopter.	60
27	Two-Per-Rev Vertical Response of the 9500-Pound UH-1H Helicopter.	61
28	Two-Per-Rev Vertical Effectivity.	62
29	Two-Per-Rev Lateral Response of the 8250-Pound UH-1H Helicopter.	63
30	Two-Per-Rev Lateral Response of the 9500-Pound UH-1H Helicopter.	64
31	Two-Per-Rev Lateral Effectivity	65
32	Two-Per-Rev Longitudinal Response of the 8250-Pound UH-1H Helicopter.	66
33	Two-Per-Rev Longitudinal Response of the 9500-Pound UH-1H Helicopter.	67
34	Vibratory Response of the UH-1 Horizontal Stabilizer.	73
35	Four-Per-Rev Vertical Response of the 8250-Pound UH-1H Helicopter.	74

LIST OF ILLUSTRATIONS (Continued)

<u>Figure</u>		<u>Page</u>
36	Four-Per-Rev Vertical Response of the 9500-Pound UH-1H Helicopter.	75
37	Four-Per-Rev Lateral Response of the 8250-Pound UH-1H Helicopter.	76
38	Four-Per-Rev Lateral Response of the 9500-Pound UH-1H Helicopter.	77
39	Four-Per-Rev Longitudinal Response of the 8250-Pound UH-1H Helicopter	78
40	Four-Per-Rev Longitudinal Response of the 9500-Pound UH-1H Helicopter	79
41	One-Per-Rev Response of the Transmission.	83
42	Two-Per-Rev Response of the Transmission.	84
43	Four-Per-Rev Response of the Transmission	85
44	Transmission Mount Schematic.	89
45	Relative Deflection Between Transmission and Fuselage for the 8250-Pound Helicopter.	91
46	Relative Deflection Between the Transmission and Fuselage for the 9500-Pound Helicopter.	92
47	Transmission Mount Schematic.	94
48	Angular Misalignment of the Engine Drive Coupling in the DAVI-Modified UH-1H	95
49	Two-Per-Rev Vertical Response of the 9500-Pound DAVI Modified Vehicle	98
50	UH-1H Moment Distribution	99
51	Main Rotor Blade Parameters	100
52	One-Per-Rev Vertical Response of the DAVI-Modified Vehicle.	104

LIST OF ILLUSTRATIONS (Continued)

<u>Figure</u>		<u>Page</u>
53	One-Per-Rev Lateral Response of the DAVI-Modified Vehicle.	105
54	One-Per-Rev Longitudinal Response of the DAVI-Modified Vehicle	106
55	Two-Per-Rev Vertical Responses of the DAVI-Modified Vehicle	107
56	Two-Per-Rev Lateral Responses of the DAVI-Modified Vehicle	108
57	Two-Per-Rev Longitudinal Responses of the DAVI-Modified Vehicle	109
58	Four-Per-Rev Vertical Responses of the DAVI-Modified Vehicle	110
59	Four-Per-Rev Lateral Responses of the DAVI-Modified Vehicle	111
60	Four-Per-Rev Longitudinal Responses of the DAVI-Modified Vehicle	112
61	Original UH-1H Isolation System	121
62	Original UH-1H Structure (Isolator Area).	123
63	Rotor Isolation System UH-1H Modified	125
64	Forward Left DAVI Transmission Mount.	127
65	Modified Structure Rotor Isolation System	129
66	Schematic of Engine-Transmission.	132
67	DAVI Transmission Mount	133
68	Lift Link DAVI.	135
69	Original UH-1H Control System	139
70	UH-1H Isolated Controls Rotor Isolation Program	141
71	Sign Convention	145

LIST OF ILLUSTRATIONS (Continued)

<u>Figure</u>		<u>Page</u>
72	Transmission Mount Geometry.	146
73	Idealized Mounting Plane Geometry, Mount Spring Rates and Motions	147
74	Collective Control Schematic	152
75	Cyclic Control Schematic	153
76	Inertia Bars	159
77	UH-1H Trim Characteristics With Two Rotor Isolation Systems.	162
78	UH-1 Speed Stability With Standard Isolation and DAVI Isolation	163
79	Effect of DAVI Isolation on UH-1H Steady Sideslip.	164
80	Effect of Isolation System on Control Response	165
81	Operating Envelope, Bottoming Load Factor vs CG Station for the Hover-Collective Pull-Up Condition.	174
82	DAVI Load Vs CG Station - Right Fwd DAVI, Trimmed Level Flight Forward Speed Conditions.	175
83	Constant Bank Angle Turns @ 50-95 Knots Where the Operating Envelope is Imposed by DAVI Bottoming, CG and Power Limitations (8250 and 9140 Lb)	176
84	Pivot Test	182
85	DAVI Tuning Rig.	187
86	Schematic of Endurance Test Rig.	189
87	Endurance Rig.	190
88	Load Vectors for 100 Percent of the Limit Load	197
89	Schematic Diagram of Proof-Load Test	198

LIST OF ILLUSTRATIONS (Continued)

<u>Figure</u>		<u>Page</u>
90	Test Set-Up for DAVI Installation Proof Load Test.	199
91	Mid-Section Structure Location of Strain Gages for Proof Load Test.	200
92	Load Vectors for 70 Percent of the Limit Load.	202
93	Load Vectors for 125 Percent of the Limit Load	203
94	Strains From Transmission Support Plate.	204
95	Strains From Fuselage Gages.	205
96	Rosette Strain Gage No. 5, Measured Stresses	206
97	Proof Load Test of Modified Flight Controls.	207
98	Proof Load Test, Cyclic Controls	210
99	Proof Load Test, Collective Controls	211
100	Baseline Ground Vibration Survey Test Setup With UH-1H Helicopter in Position.	212
101	Vertical Response of the Tail for a Vertical Input at Main Rotor Hub.	214
102	Two-Per-Rev Vertical Response.	224
103	DAVI Isolator Functional Block Diagram	231
104	DAVI Isolator Reliability Block Diagram.	232

LIST OF TABLES

<u>Table</u>		<u>Page</u>
1	FLIGHT TEST CONDITIONS.	38
2	INSTRUMENTATION	40
3	ONE-PER-REV VIBRATORY RESPONSE OF THE 8250- POUND TEST VEHICLE FOR STEADY-STATE TURNS	58
4	ONE-PER-REV VIBRATORY RESPONSE OF THE 9500- POUND TEST VEHICLE FOR STEADY-STATE TURNS	59
5	TWO-PER-REV VIBRATORY RESPONSE FOR THE 8250- POUND TEST VEHICLE FOR STEADY-STATE TURNS	70
6	TWO-PER-REV VIBRATORY RESPONSE FOR THE 9500- POUND TEST VEHICLE FOR STEADY-STATE TURNS	71
7	FOUR-PER-REV VIBRATORY RESPONSE FOR THE 8250- POUND TEST VEHICLE FOR STEADY-STATE TURNS	81
8	FOUR-PER-REV VIBRATORY RESPONSE FOR THE 9500- POUND TEST VEHICLE FOR STEADY-STATE TURNS	82
9	VIBRATION RESPONSES OF THE TRANSMISSION FOR STEADY-STATE TURNS.	87
10	MEASURED DEFLECTION OF DAVI MOUNTS.	90
11	MEASURED COUPLING MISALIGNMENT.	97
12	ONE-PER-REV VIBRATORY RESULTS FOR THE OUT-OF-TRACK CONDITIONS	102
13	SPRING RATES OF THE UH-1 ISOLATION SYSTEM	115
14	DESIGN SPRING RATES OF THE DAVI ISOLATION SYSTEM.	117
15	CALCULATED NATURAL FREQUENCIES OF THE SYSTEMS	117
16	EFFECTIVE SPRING RATES OF THE STANDARD AND DAVI UH-1 ISOLATION SYSTEMS	118
17	DESIGN CRITERIA	119

LIST OF TABLES (Continued)

<u>Table</u>		<u>Page</u>
18	LOAD FACTORS, ANGULAR ACCELERATIONS, ROTOR LOADS AND MAST ROTOR TORQUE COMPONENTS FOR CRITICAL FLIGHT, LANDING AND CRASH CONDITIONS.	148
19	SUMMARY - LIMIT PYLON MOUNT LOADS	149
20	CONTROL SYSTEM LOADS.	151
21	SUMMARY OF MINIMUM MARGINS OF SAFETY.	154
22	DAVI INERTIA BAR LOADS.	159
23	SUMMARY OF FATIGUE ANALYSES	160
24	SUMMARY OF UH-1H STICK FIXED STABILITY WITH TWO ISOLATION SYSTEMS.	166
25	DAVI TRAVEL REQUIREMENTS.	168
26	MAXIMUM TRAVEL OF DAVI DESIGN	169
27	SUMMARY OF FLIGHT CONDITIONS.	170
28	CALCULATED DEFLECTION OF DAVI MOUNTS.	178
29	CALCULATED MISALIGNMENT OF THE COUPLING	179
30	GROUND TEST INSTRUMENTATION	181
31	PIVOT TEST.	183
32	AVERAGE DAVI SPRING RATES	184
33	STANDARD MOUNT SPRING RATES	185
34	DAVI TUNING	188
35	ROTOR TRIM FORCES	191
36	ENDURANCE RIG TWO-PER-REV RELATIVE MOTIONS.	193
37	ENDURANCE RIG TWO-PER-REV VIBRATORY MISALIGNMENT OF THE ENGINE DRIVE COUPLING.	194

LIST OF TABLES (Continued)

<u>Table</u>		<u>Page</u>
38	COMPARATIVE DAVI SPRING RATE.	195
39	PREDOMINANT NATURAL FREQUENCIES AND RESPONSES	215
40	PREDOMINANT VIBRATION LEVELS OF THE UH-1H HELICOPTER.	217
41	EXPECTED VERTICAL VIBRATION LEVELS OF THE UH-1H HELICOPTER AT 116 KNOTS	222
42	UNDAMPED NATURAL FREQUENCY.	226
43	NORMALIZED RESPONSE	227
44	SPRING RATE	228
45	DAVI FAILURE MODES AND EFFECTS ANALYSIS	234
46	ESTIMATED FAILURE RATE REDUCTION FOR DAVI-EQUIPPED UH-1H	241
47	ESTIMATED MAINTENANCE LABOR SAVINGS FOR DAVI-EQUIPPED UH-1H	243
48	ISOLATION SYSTEM WEIGHT	246

ROTOR ISOLATION - USAAMRDL PROGRAM REVIEW

This report represents the culmination of a U. S. Army Air Mobility Research and Development Laboratory (USAAMRDL) search for an effective, light weight, practical helicopter rotor isolation system. This search, some ten years in duration, consisted of a series of investigations wherein consideration was given to both passive and active isolation concepts. For these reasons, it was deemed appropriate that USAAMRDL provide a program review to accompany this report.

The sources, the problems, and the detrimental effects of high-level, low-frequency helicopter vibration are well known to the industry and the Army. The Army has long recognized the need for helicopter vibration reduction and, for many years, has sought to reduce vibration through research in rotor dynamics, structural dynamics, and vibration mitigation devices.

The major sources of these vibration problems are the rotor-induced shears and moments. These shears and moments produce a hub input at a frequency in the fixed system that is an integral multiple of the number of blades in the rotor system. The predominant excitation frequency is the n-th harmonic of an n-bladed rotor.

One means of vibration reduction, and perhaps the most viable near-term solution, is isolation of the complete fuselage from the rotor-induced forces - often referred to as rotor isolation. The Eustis Directorate, USAAMRDL, Fort Eustis, Virginia, subscribes to this viewpoint and has been sponsoring research in rotor isolation for the past ten years.

The concept of rotor isolation is not new. Conventional passive devices that isolate inplane rotor forces have been successfully incorporated into production helicopters for over fifteen years, the Army's UH-1 series helicopters being the most prominent case. The crux of helicopter rotor isolation is one of providing adequate low-frequency isolation without excessive relative displacement or loss of mechanical stability. Isolating the large vertical lifting forces of a helicopter rotor while maintaining a low relative displacement has precluded effective isolation in the vertical direction by conventional means. Three major analytical studies of isolating the fuselage from the rotor system were

conducted between 1957 and 1962 (References 1, 2, and 3). Reference 1, incidentally, is the earliest recorded investigation of vertical rotor isolation. All three studies reached the same basic conclusion: active systems were required to provide isolation in the vertical direction. Active devices require some form of external power (generally hydraulic, pneumatic, electric, or some combination of these), feedback loops employing servovalves, and electronic signal conditioning equipment. These systems lacked the simplicity and therefore the practicality, to warrant their use in retrofitting current helicopters. As a result, full-scale experimental demonstration of the feasibility of these systems was not initiated.

Thus, at the outset of this USAAMRDL program, initiated some ten years ago, the challenge was to successfully flight-demonstrate an isolation system capable of isolating a helicopter's fuselage from vertical and inplane rotor excitation while being sufficiently light in weight, small in size, and mechanically simple to warrant use in current or proposed new helicopters.

In 1965, the Army received favorable replies to a letter for Information and Planning soliciting the helicopter industry's opinion regarding the timeliness of a parametric study of helicopter rotor isolation feasibility. The consensus of these replies also concurred in the soundness of restricting such a study to the less complex rigid-body analyses for assessing the relative merits of isolation system concepts with confirmatory tests of the best performing systems to follow. As the result of a competitive procurement in 1966, two analytical studies (one active, the other passive) were initiated to investigate the feasibility of helicopter rotor isolation. The results of these studies are reported in References 4 and 5.

- ¹ Theobald and Jones, ISOLATION OF HELICOPTER ROTOR VIBRATION FORCES FROM THE FUSELAGE, Kaman Aircraft, Bloomfield, CT, WADC Technical Report 57-404, Wright Air Development Center, Dayton, OH, September 1957.
- ² Crede and Cavanaugh, FEASIBILITY STUDY OF AN ACTIVE VIBRATION ISOLATOR FOR A HELICOPTER ROTOR, Barry Wright Corp., WADC Technical Report 58-163, Wright Air Development Center, Dayton, OH, October 1958.
- ³ Smollen, Marshall and Gabel, A SERVO-CONTROLLED ROTOR VIBRATION ISOLATION SYSTEM FOR THE REDUCTION OF HELICOPTER VIBRATION, Institute of Aerospace Sciences Paper No. 62-34, New York, NY, January 1962.
- ⁴ Schuett, PASSIVE HELICOPTER ROTOR ISOLATION USING THE KAMAN DYNAMIC ANTIRESONANT VIBRATION ISOLATOR (DAVI), USAAMRDL Technical Report 68-46, Eustis Directorate, U. S. Army Air Mobility Research and Development Laboratory, Fort Eustis, VA, December 1968, AD 687324.
- ⁵ Calcaterra and Schubert, ISOLATION OF HELICOPTER ROTOR-INDUCED VIBRATIONS USING ACTIVE ELEMENTS, USAAMRDL Technical Report 69-8, Eustis Directorate, U. S. Army Air Mobility Research and Development Laboratory, Fort Eustis, VA, June 1969, AD 859806.

In Reference 4, rotor isolation in all directions was shown to be analytically feasible for "statistical" helicopters ranging in weight from 2,000 to 100,000 pounds. Since the n-th harmonic or n/rev of an n-bladed rotor is the predominant excitation frequency, antiresonant isolation appeared to be an ideal solution to helicopter rotor isolation. Using a unique passive isolator, the Dynamic Antiresonant Vibration Isolator (DAVI), conceptual arrangements were studied for isolating the fuselages of various size helicopters from their rotor and transmission or from their rotor, transmission, and engine. The DAVI is based on inertial coupling. By the adjustment of a weighted lever, it can be tuned to provide an antiresonance at the predominant excitation frequency. That is, at its tuned frequency (the n/rev), the force from the inertia bar cancels the spring force causing the isolated pivot (the transmission/fuselage attachment point) to be a node point, thereby providing virtually 100-percent isolation. Results indicated that a high isolation system stiffness was possible, thereby minimizing relative displacement and the attendant problems of engine drive coupling misalignment, undesirable control system inputs, and the potential loss of mechanical stability. Being passive, the DAVI didn't require external power or signal conditioning equipment. Furthermore, it was mechanically simple, could be small in size and in envelope requirements. Thus, it was potentially light in weight and amenable to isolation system/airframe integration.

Reference 5 presents the results of a study using a unidirectional active isolation system. In this study, an electrohydraulic isolator exhibiting narrow bandwidths of isolation at frequencies corresponding to the blade passage frequency and its second and third harmonics was used. Single rotor helicopters with gross weights of 2,000 pounds through 80,000 pounds and blade passage frequencies of 13.3 Hz through 26.6 Hz were considered. The system, being active, required external hydraulic and electrical power as well as electronic signal conditioning equipment. Based on some gross simplifying assumptions of the physical system, impressive vibration attenuation and displacement control were predicted with an associated high weight penalty (4-5 percent gross weight). The trend of these results shows that for the application of this isolator to configurations of lower blade-passage frequency than the 13.3 Hz studied, such as 10 Hz (typical of UH-1 and CH-47), both displacement and system weight would increase markedly. At 10 Hz blade passage frequency, relative displacement would double, and weight would increase to approximately 8 percent of gross weight. Also, the validity of this study was clouded by the simplifying assumptions. Chiefly, the isolator was interposed between the rotor and transmission and the rotor shaft was assumed to be capable of transmitting torque from the fuselage-mounted transmission to the rotor while allowing relative vertical displacement between the rotor and the fuselage. In addition, the analysis considered vertical excitation only. Due to these simplifying assumptions, together with the system's complexity and weight, USAAMRDL concluded that feasibility had not been established.

Upon completion of these feasibility studies, USAAMRDL sponsored two full-scale ground vibration tests to demonstrate the feasibility of isolation systems providing vertical and inplane rotor isolation. As with the feasibility studies, one effort was for an active system, the other for a passive system. The results of these feasibility demonstrations are reported in References 6 and 7.

In the experimental program of Reference 6, the DAVI, shown to be feasible in the earlier study, was tested. For this program, a 3-directional isolation system incorporating four DAVIs of a single size suitable for installation at the transmission/airframe interface in either a 6,500-lb or a 10,000-lb vehicle was designed. The DAVI spring elements provided torque restraint. Isolator parameters were not optimized for either gross weight or any rotor configuration. The test vehicle, a stripped UH-2 helicopter, was ballasted to 6,500 lb gross weight to simulate a UH-1 helicopter. The rotor and transmission were simulated by an upper body with proper weight and inertial characteristics. The free-flight condition was simulated by suspending the test vehicle from the rotor by a bungee and, in turn, suspending the fuselage from the upper body by the isolation system. Tests consisted of sequentially exciting the rotor hub with an electromechanical shaker in the vertical, lateral, and longitudinal directions. The levels of excitation were of sufficient magnitude to induce responses of approximately $\pm 2g$ throughout the unisolated aircraft. The frequency of excitation was varied to represent a two-, three-, and four-bladed helicopter. Excellent isolation and displacement control were attained, confirming earlier predictions. Results were particularly good for the three- and four-bladed configurations. At their predominant excitation frequencies (3/rev and 4/rev), the average isolation for the two cases was 90% and 70% in the vertical and inplane directions, respectively. For the two-bladed case, average isolation was 58% in both the vertical and inplane directions. The two-bladed results were good considering the difficulty of affording isolation for this configuration. To appreciate the difficulty, consider the following: (1) the predominant rotor excitation frequency (2/rev) is approximately 10 Hz while the 1/rev is very close at 5 Hz; (2) in order to preclude the occurrence of ground resonance for articulated-rotor cases, the isolation's natural frequency must be above the 1/rev frequency; and (3) the predominant fuselage response modes are close to the 1/rev excitation frequency. Because of the very close proximity of these fuselage and rotor excitation frequencies, the introduction of an

⁶ Jones, A FULL-SCALE EXPERIMENTAL FEASIBILITY STUDY OF HELICOPTER ROTOR ISOLATION USING THE DYNAMIC ANTIRESONANT VIBRATION ISOLATOR, USAAMRDL Technical Report 71-17, Eustis Directorate, U. S. Army Air Mobility Research and Development Laboratory, Fort Eustis, VA, June 1971, AD 729317.

⁷ von Hardenberg and Saltanis, GROUND TEST EVALUATION OF THE SIKORSKY ACTIVE TRANSMISSION ISOLATION SYSTEM, USAAMRDL Technical Report 71-38, Eustis Directorate, U. S. Army Air Mobility Research and Development Laboratory, Fort Eustis, VA, September 1971, AD 736347.

isolation system natural frequency in their midst makes the two-bladed configuration most difficult to isolate. The greater difficulty of the two-bladed application is graphically illustrated by the following two figures. In Figure 1, the classical transmissibility-versus-frequency curve is shown for a DAVI tuned to provide an antiresonance at the 2/rev excitation frequency. Transmissibility is defined as the ratio of response ($\pm g$'s) at the isolated side of the DAVI to that at the non-isolated side of the DAVI. For the above cited reasons, the DAVI resonant frequency is shown placed above 1/rev.

In contrast, Figure 2 shows a transmissibility curve for a DAVI tuned to provide antiresonance at the 4/rev excitation frequency with the resonant frequency again placed above 1/rev. Clearly, the four-bladed case with the broader spread between 1/rev and blade-passage frequency is more amenable to antiresonant isolation. In the four-bladed application, this "broad spread" not only allows the DAVI resonance to be placed well above the 1/rev, thereby precluding ground resonance, but also permits greater latitude or design freedom in its placement, thus avoiding structural resonances of the predominant fuselage response modes. More importantly, because it is at a higher frequency, the four-bladed application is less sensitive to damping. Damping has the effect of lowering the response at the resonant peak and reducing the isolation provided at antiresonance or within the antiresonant "bucket". Because of this and the ability to place the DAVI resonance sufficiently far from the 4/rev excitation frequency, a better, broader bandwidth (wider antiresonant bucket) may be realized. Figure 3 graphically illustrates the profound effects discussed above of blade-passage frequency and damping on isolation. The inset relates the physical significance of the frequency ratio to isolation system resonance, antiresonance, and blade-passage frequency. Clearly, for the 2-bladed UH-1 configuration where the frequency ratio $a/\Omega = 1.2$, isolation is most sensitive to damping and dynamically most challenging. From these results, it was concluded that the feasibility of the DAVI concept had been demonstrated.

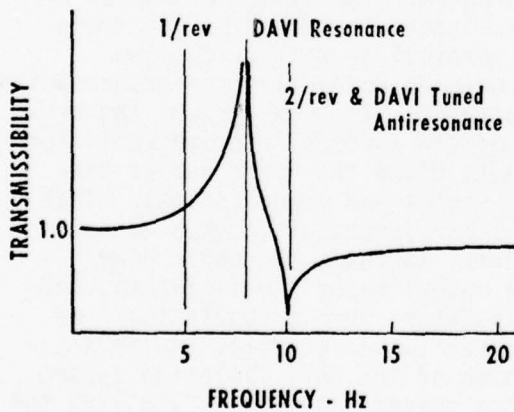

Figure 1. Two-Bladed Case

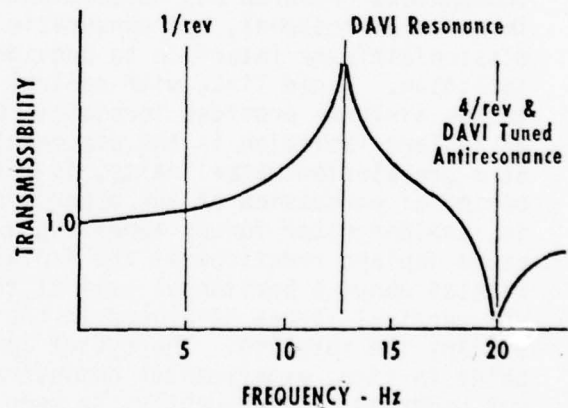

Figure 2. Four-Bladed Case

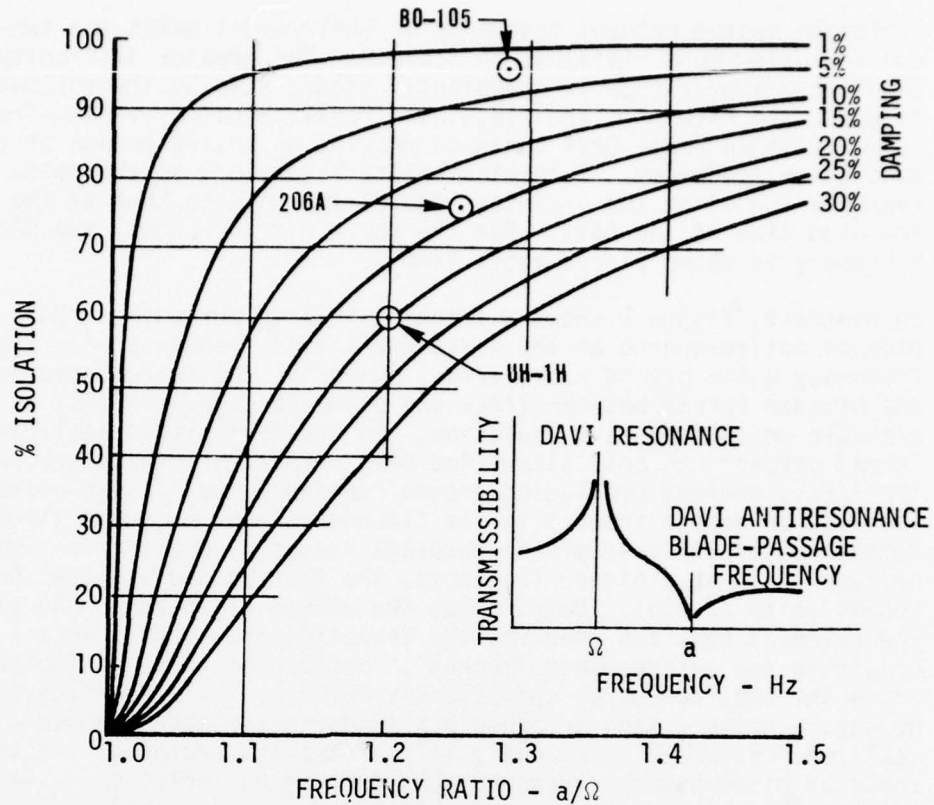

Figure 3. Isolation vs Frequency Ratio

The experimental results of an active isolation system on a six-bladed CH-53A helicopter are reported in Reference 7. Prior to USAAMRDL's support of this demonstration, Sikorsky Aircraft Corporation conducted a feasibility study of helicopter rotor isolation under their corporate independent research and development program. The system consisted of three unidirectional, hydropneumatic isolators installed at the transmission/airframe interface to provide vertical as well as inplane isolation. Rigid links with control rod-ends connecting the transmission to the airframe provided torsional restraint. In this system, the crux of inplane isolation is the placement of the vertically oriented isolators at a preselected waterline to, in effect, place the rotor hub at the center of percussion of the upper body (rotor and transmission). That is, inplane rotor forces appearing as shear forces at the hub do not cause inplane reactions at the isolators. Instead, the upper body rotates about a horizontal axis at the waterline of the isolators, and the vertical forces developed in the isolators form a couple that restrains the rotation. The system appeared to be feasible. At this point in time, experimental demonstration of the DAVI isolation system was underway. Consequently, to keep the competition "alive", giving the

Army the opportunity to more fully assess the merits of both passive and active isolation systems before committing Army funds to a more costly flight test demonstration, an experimental demonstration of Sikorsky's active isolation system was initiated. The six-bladed, 35,000-lb CH-53A was selected as the test vehicle. Ground vibration testing was conducted in a manner similar to that described above for the DAVI. Excellent isolation and displacement control were attained, confirming earlier predictions. At the predominant excitation frequency (6/rev), average isolation in the vertical and inplane directions were 68% and 71%, respectively. The system had an almost negligible power penalty (16 horsepower) that could be operated as an integral part of the 3,000-psi onboard hydraulic system. However, the isolation system was very complex and heavy - too much so to warrant retrofitting any current Army helicopter. A production isolation system weighing 370 pounds (1.1% GW) was projected for the 35,000-lb CH-53. This was possible only through extensive airframe structure and transmission housing modifications. Feasibility appeared to be limited to new helicopter designs, where the necessary design freedom for isolator placement and weight savings could be realized. In terms of isolation, complexity, and weight, this system appears best suited, if not limited, to large, multi-bladed helicopters. This is because of the following two reasons: First, the performance of a helicopter rotor isolation system is directly related to the number of rotor blades. Generally speaking, the more blades a helicopter rotor has, the less difficult it is to achieve effective isolation. This, of course, is because of the "spread" between 1/rev and blade-passage frequency, discussed above. Second, isolation system weight as a percentage of gross weight varies inversely with helicopter gross weight. Thus, for any given isolation system concept and comparable design requirements, the maximum weight penalty will be for the lowest gross weight vehicle. In addition to these practical constraints of system performance, complexity, and weight, the anticipated flight performance remains clouded. Specifically, the "focusing" parameters used in the ground vibration test were selected to best isolate inplane vibratory rotor shear forces. However, for an articulated rotor, vibratory hub moments, although not quite as important, are also of some concern. Furthermore, the focusing requirements for inplane hub shears and moments are not compatible. To isolate both requires some form of compromise to achieve a best net effect. The ground vibration test included hub shears only. Thus, the isolation system's performance in the presence of both hub shears and moments is unknown.

After the completion of these demonstrations, USAAMRD concluded that a passive isolation system, the DAVI, was the most promising. It not only performed well but would work on a broad range of helicopters, regardless of size or rotor type. Being mechanically simple, it was inherently reliable. Because it could be light in weight and small in size, it had

retrofit potential. Further, the DAVI concept had been well researched, and its development bore the least risk. For these reasons, USAAMRD selected the DAVI to be flight test demonstrated. The UH-1H was selected to be the test vehicle. The reasons for USAAMRD's selection follow:

(1) Availability - there were more UH-1 series helicopters in the Army inventory than any other type. Of these, the H model was the most recent.

(2) As noted above, UH-1 series helicopters employ an inplane isolation system. That is, they have the rotor and transmission mounted on elastomeric elements to minimize the transmission of inplane rotor-induced forces to the fuselage. The removal of this system would provide much of the space necessary for installing a new isolation system, thus requiring minimal structural modification and program cost.

(3) Rotor isolation is directed at one of the helicopter's most basic problems - vibration. The attenuation of vertical rotor-induced vibratory forces had remained elusive. For the UH-1 and AH-1 series helicopters, a rigid link connects the rotor and transmission to the fuselage. This link not only carries the static lift load but also transmits vertical vibratory forces directly from the rotor to the fuselage, causing fairly high vibration levels. Over the years, the gross weight of the UH-1 had grown from 6,600 to 9,500 lb, aggravating the situation. In 1967, the Bell Helicopter Company experimented with a servo-controlled hydraulic actuator (called an active lift link) to replace the rigid lift link. Flight test results were disappointing. Excellent isolation of 1/rev excitation was realized, but the isolation of the predominant 2/rev excitation met with only limited success. With these results, the Bell Helicopter Company's pursuits returned to techniques for arranging their passive isolators (called pylon focusing) to attenuate rotor-induced fuselage vibration. Only modest gains were realized over a protracted period of research. Thus, with retrofitting a possibility and the UH-1 experiencing a growing vibration deficiency when compared to Military Specifications, the choice of the UH-1H was well-founded.

(4) For the reasons discussed above, the two-bladed UH-1 represented, from the dynamic viewpoint, the most difficult case. Also, because of the UH-1's relatively low, 6,600-lb design gross weight, it presented a design challenge in terms of weight penalty.

Having selected a DAVI isolation system to be flight test demonstrated on a UH-1H helicopter, a six-phase program was planned. This program, documented in this report, consisted of the following:

PHASE 1 - Baseline flight vibration survey of the UH-1H demonstration vehicle.

PHASE 2 - Baseline ground vibration survey (shake test), including an assessment of the influence/effectiveness of the production inplane isolation system.

PHASE 3 - Isolation system design and analysis.

PHASE 4 - Fabrication of isolation system and aircraft modifications.

PHASE 5 - Confirmatory ground tests of modified vehicle including component tests, a 100-hour system endurance test, and a system proof test.

PHASE 6 - Flight test evaluation.

During the performance of the program reported on herein, two prime helicopter manufacturers, Bell Helicopter Company and Boeing Vertol, independently initiated and/or accelerated their research and development of rotor isolation systems. As stated above, isolation in the vertical direction is precluded by conventional means. Therefore, to achieve vertical isolation, both companies resorted to antiresonant systems that are intrinsically DAVI systems.

Bell Helicopter's approach has been to combine pylon focusing with antiresonant vibration isolators to achieve isolation in the inplane and vertical directions, respectively. The term "pylon" as used by Bell refers to the rotor and transmission. As previously stated in this program review, Bell Helicopter had been pursuing pylon focusing for many years, during which many kinematic arrangements were investigated. This work culminated in the development of a focused A-frame transmission mount for inplane isolation. In this arrangement, shown in Figure 4, the transmission is mounted by elastomeric bearings to two rigid A-frames longitudinally positioned along each side of the transmission. Each A-frame is "focused", strategically placing the pylon/A-frame mounting points so that the angular pitching response of the pylon is minimized and the inplane hub shears are reacted by a pair of vertically oriented couples at the base of each A-frame. Fuselage pitching moments due to inplane hub shear forces are offset or cancelled by opposing moments developed about the fuselage center of gravity by the pylon-restraint spring. This elastomeric spring (not shown in Figures) is installed beneath the transmission. The waterline location of the focal point, which is the pylon A-frame/mounting point, is a function of the stiffness of this spring, as well as the height of the A-frame. Vertical hub forces are transmitted directly through the A-frames to the nodal beams. Transmission torque is restrained by a pair of links connecting the lower transmission to the fuselage. Suitable rod-end type bearings are employed, allowing freedom of vertical motion without affecting nodalization. Figures 4 and 5 schematically illustrate how two nodal beam configurations respond to vertical excitation.

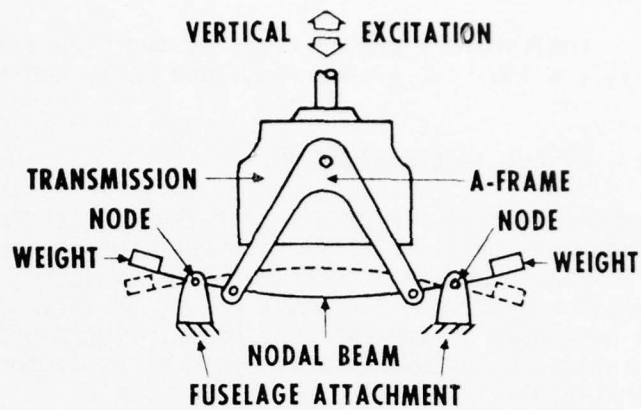

Figure 4. Early Version of Bell's Focused Pylon/Nodal Beam Isolation System

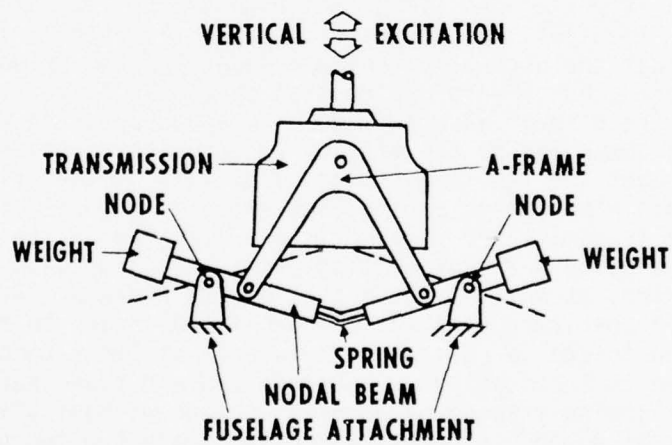

Figure 5. Recent Version of Bell's Focused Pylon/Nodal Beam Isolation System

As shown in these figures, each A-frame is mounted to a nodal beam to which the fuselage is also attached. These nodal beam attachments initially utilized dry-lubricated, TEFLON-type bearings, although more recently elastomeric bearings have also been employed. "Nodalizing" weights, secured to the ends of each nodal beam, "tune" the beam, causing each nodal beam/fuselage attachment point to be an antiresonance or node. Figure 4 is a schematic of Bell's earlier work on the Model 206A Jet Ranger, wherein the flexural elasticity of the beam served as the spring element. In subsequent developments, the "flexible" nodal beam has given way to a more rigid nodal beam with a discrete spring at its mid span. Figure 5 is a schematic of this latter development.

Bell Helicopter's results on the Jet Ranger were outstanding. These results, taken from Reference 8 and shown in Figure 6, show a very low, $+0.05 - .07g$ response throughout the speed range for $1.0g$ level flight. Although it is not shown in this figure, the standard Jet Ranger does have the classical roughness normally associated with low-speed transitional flight. This roughness has been eliminated by the isolation system's nodal beam.

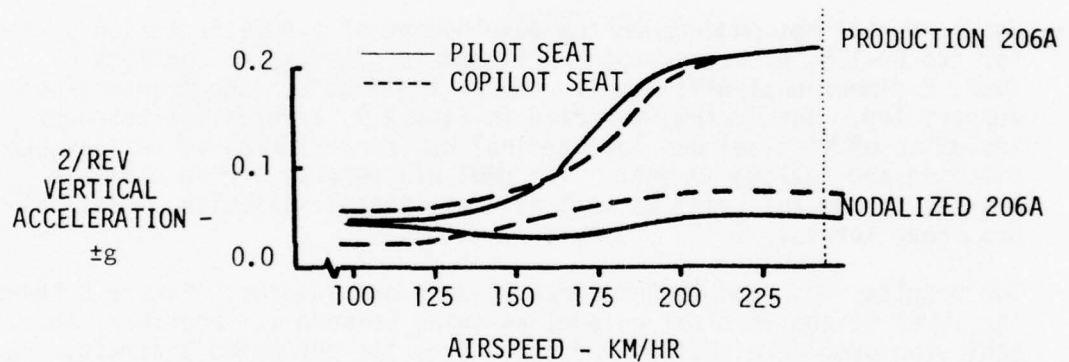

Figure 6. Jet Ranger Flight Test Results

⁸ Shipman, NODALIZATION APPLIED TO HELICOPTERS, Society of Automotive Engineers Paper Number 730893, Presented at National Aerospace Engineering and Manufacturing Meeting, Los Angeles, California, October 1973.

Nodal isolation systems, basically as illustrated in Figure 5, are in production on two models: the 214/A/B/C Tactical Transport and the 206L Long Ranger. Similar systems are under development for the YAH-63 Advanced Attack Helicopter and the Model 222 commercial light twin helicopter.

Pylon focusing, it should be noted, cannot be simultaneously achieved for the isolation of both inplane hub forces and hub moments. The requirements for each are incompatible. Bell Helicopter's focused pylon systems are for the isolation of inplane shear forces, since their rotor systems are teetered and hub moments are not developed. However, for "rigid-" and articulated-rotor systems, vibratory hub moments, as well as inplane shears, are of concern. If focusing is attempted for such a system, some trade-off or compromise between inplane and moment focusing would appear to be necessary to achieve the best results. To enhance handling qualities, control power, and pilot workload for teetered-rotor systems to be used in nap-of-the-earth maneuvers necessary for observation and attack missions, Bell Helicopter has done developmental work with the high energy rotor and flapping-moment hub-springs. Because of the hub-spring, these teetered-rotor systems "fall" into the "rigid-" and articulated-rotor category for pylon focusing purposes. Consequently, the development of an effective pylon focusing system for these vehicles that performs as well as ones for comparably sized teetered-rotor systems may prove to be very difficult.

Boeing-Vertol has undertaken the development of a DAVI isolation system for its BO-105, hingeless-rotor helicopter. The system consists of four, 2-dimensional DAVI mounts, one at the foot of each transmission support leg. The system, depicted in Figure 7, affords antiresonant isolation of vertical and longitudinal hub shear forces as well as hub pitching and rolling moments. The DAVI elastomeric spring elements provide torque restraint as well as conventional isolation of lateral hub shear forces.

The results, reported in Reference 9, were outstanding. Figure 8 shows the level-flight vertical g level as being between .01 and .05g, thus achieving over an eightfold reduction from the untreated aircraft. Again, as with Kaman and Bell, the roughness associated with transitional flight has been eliminated. The vibration levels during a normal approach and landing flare were also significantly reduced, by a factor of ten.

⁹ Ellis, Diamond and Fay, DESIGN DEVELOPMENT AND TESTING OF THE BOEING VERTOL/YUH-61A, American Helicopter Society Paper Number 1010, Presented at 32nd National Annual Forum, Washington, D.C., May 1976.

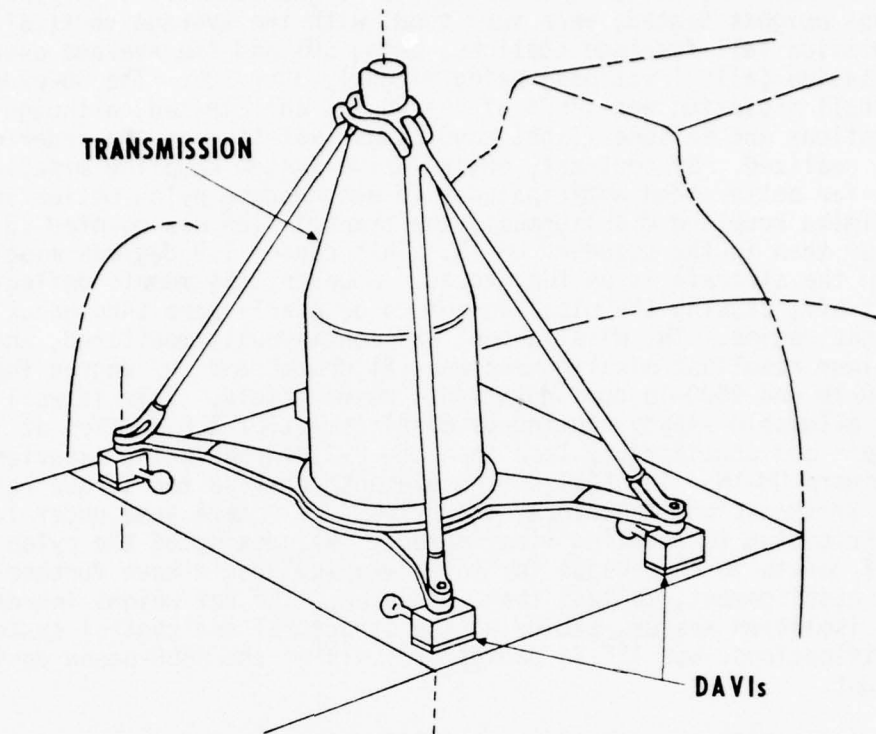

Figure 7. BO-105 Isolation System

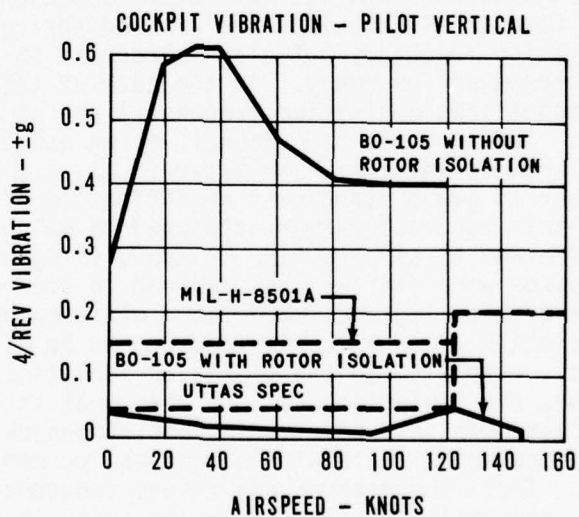

Figure 8. BO-105 Vibration Levels

Kaman's UH-1 results, considering all flight conditions for the two gross weights tested, were very good, with the average vertical 2/rev isolation (all fuselage stations) being 60% and the average overall isolation (all directions) being slightly over 50%. The 50-plus percent overall isolation was short of the 60-75% anticipated, although at some locations and in some flight conditions isolation on the order of 75-80% was realized. By contrast, engine/drive system coupling misalignment was far better than anticipated. To accommodate pylon motion yet minimize coupling misalignment, the transmission was mounted .3 inch lower than in the standard UH-1H. This causes 1.9 degrees misalignment when the aircraft is on the ground. However, the mounts deflect after lift-off, causing the misalignment to be nearly zero throughout the 1.0g flight regime. The misalignment was continuously monitored, and the maximum resultant misalignment was .81 degree and .97 degree for the 8250-lb and 9500-lb configurations, respectively. This is well within the allowable steady continuous misalignment of 2.0 degrees at 1100 horsepower; and considerably less than the 2-3 degrees being experienced in the standard UH-1H. The DAVI spring elements provide the torque restraint of the transmission; therefore, the pylon does rotate some under load, contributing to coupling misalignment. Reindexing of the pylon on the DAVI mounts to compensate for this "wrap-up" could have further reduced the misalignment, to less than .5 degree. The net weight increase for the isolation system, excluding the structural and control system modifications, was 125.85 pounds or 1.91% of the 6600-pound design gross weight.

In assessing these results, one should bear in mind that system optimization was never attempted. Some comments as to why the isolation results were not as good as anticipated and how these results could be improved, follow. A concern with any antiresonant rotor isolation system such as the DAVI is that it not only provides the desired antiresonance at the predominant excitation frequency but also introduces an "additional" pylon natural or resonant frequency. In the case of the UH-1, the 1/rev and the 2/rev (predominant excitation frequency) are at 5.4 Hz and 10.8 Hz, respectively. Ideally, the "additional" pylon natural frequency should be midway between the 1/rev and 2/rev (i.e., 7.9 Hz) - sufficiently removed from either to avoid structural amplification of any dynamic response. Under this contract, Kaman attempted to match existing UH-1H pylon-mount stiffnesses to simplify the system's integration task. The resultant stiffnesses were stiffer than desired in the vertical direction and softer in the torsional direction. These differences in stiffness caused the "additional" pylon natural frequency to be higher than desired (9.0 Hz vs 7.9 Hz), resulting in the vibration isolation provided. So, although very good, the isolation was less than what it might have been. Figure 3 best illustrates this point. The antiresonance, a , is 10.8 Hz, while the desired and actual natural frequencies, Ω , are 7.9 Hz and 9.0 Hz, respectively. Thus, the desired and actual frequency ratios, a/Ω , are 1.37 and 1.2, respectively. The isolation system has about 20% damping. At the respective frequency ratios for this amount of damping, it is seen in Figure 3 that nearly 80% isolation could have been

realized - significantly better than the approximately 60% actual. Eliminating the lift-link DAVI and incorporating a portion of its spring rate into the four remaining transmission-mount DAVIs should sufficiently alter the pylon stiffness and the "additional" natural frequency to significantly improve rotor isolation. An optimized four-point mounting system has a projected weight of 84.0 pounds, or 1.27% of the design gross weight.

In comparing Bell's results with Kaman's, one should do so while keeping in mind that these organizations conducted their developmental work under different circumstances and design constraints. Bell was optimizing a production system, whereas Kaman was demonstrating system feasibility. As for design constraints, Bell's Model 206A has a long engine-transmission drive shaft which, together with the low 2900-pound GW, is relatively insensitive to coupling misalignment. Thus, they could concentrate on isolation performance and be relatively free of deflection and misalignment worries. In contrast, the UH-1 has a short drive shaft for which coupling alignment is more sensitive to displacement. This and the fact that Kaman designed for operation at 9500-pound gross weight compounded their design challenge. Kaman placed primary emphasis on maintaining the UH-1H's dynamic characteristics to preclude, with minimal effort, the occurrence of dynamic problems, thereby simplifying the system's integration task. In so doing, Kaman somewhat inadvertently achieved exceptionally low coupling misalignment. The somewhat higher than desired pylon-mount stiffness, cited above, contributed to this low misalignment. Nonetheless, using hindsight, it is apparent that even the target pylon-mount stiffness could have been lower, yielding significantly better isolation while maintaining acceptable coupling misalignment.

Although there are presently no USAAMRDL plans regarding further rotor isolation work, investigations of multi-frequency antiresonant isolation concepts, pylon focusing techniques, and low damping elastomers specifically for low isolation systems are recognized as warranting consideration. Retrofitting Army UH-1Hs with an optimized DAVI isolation system is outside the purview of the USAAMRDL. Such a decision must trade-off the cost of retrofitting against the performance, comfort, reliability and maintainability benefits. A cursory estimate of the R&M benefits in terms of 1975 dollars is presented in this report. This estimate is predicated on a premise that is supported by the findings of Reference 10 that vibration-induced failures will be reduced in proportion to the vibration reduction afforded by the DAVI isolation system. Reference 10, incidentally, was a study of Sikorsky S-61 (Air Force H-3) helicopter squadrons with and without the Sikorsky-developed Bifilar Absorber. The results in themselves may not constitute a precise measure of the effect of vibration on R&M. However, San Francisco Oakland Airways, a

¹⁰ Veca, VIBRATION EFFECTS ON HELICOPTER RELIABILITY AND MAINTAINABILITY, Sikorsky Aircraft; USAAMRDL Technical Report 73-11, U. S. Army Air Mobility Research & Development Laboratory, Fort Eustis, Virginia, April 1973, AD 766307.

commercial carrier with many thousands of hours utilizing S-61's equipped with Bifilar Absorbers, reports similar results, lending credence to the premise. Returning to Kaman's R&M analyses, this estimate projects 52 to 67% reductions in the vibration-induced failure rates of fifteen sub-systems. A resultant 31.3% reduction in the total failure rate is estimated. This, in turn, corresponds to a projected total labor and repair parts savings of \$50.26 per flight-hour. According to Reference 11, the Army has 3208 UH-1H helicopters, of which 80.11% are actively deployed at a current utilization rate of 20 flight-hours per month. Assuming that 1000 aircraft were to be retrofitted, thereby achieving the benefit of the lower costs associated with volume production, the total cost of retrofitting is estimated to be approximately \$7,000,000. This is based on an estimated cost of about \$5,000 to modify each vehicle (\$5,000,000), in addition to a \$2,000,000 non-recurring developmental cost to optimize the envisioned DAVI system. In contrast, the annual savings would be \$12,000,000. Of this savings, \$9,600,000 could be realized from the reduced need for replacement parts; the remaining \$2,400,000 savings could be realized from the associated reduction in maintenance labor. This trade-off of R&M benefits versus retrofit costs might be summarized by saying that the entire cost to retrofit 1000 UH-1Hs could be recouped in the first seven months of operation. Based on these findings, the USAAMRDL recommends that the Army develop and implement a plan to retrofit its UH-1H fleet.

Undoubtedly, antiresonant isolation systems, whether called DAVIs, Nodal Beams or by some other label, have considerable potential for helicopter rotor isolation. The above-cited efforts, at Bell Helicopter and Boeing Vertol, attest to this. In fact, their vigorous efforts have brought antiresonant rotor isolation to fruition much sooner than could have been envisioned at the outset of this ten-year program, and certainly much sooner than if all the work had been conducted under Army sponsorship. Development of such isolation systems, including multi-frequency and multi-directional features, for future military and commercial helicopters is foreseen. Having sponsored the early research, "planting the seed" from which these concepts emerged, the USAAMRDL can view these recent developments with a sense of accomplishment. The initial goal of demonstrating the feasibility of isolating rotor-induced excitation in the vertical direction was not only accomplished, but a transfer of technology that increased the state of the art also took place, and this technology has already found its way into production systems.

¹¹ EXECUTIVE SUMMARY REPORT - UH-1H ASSESSMENT AND COMPARATIVE FLEET EVALUATION, USAAVSCOM Technical Report 75-3, U. S. Army Aviation Systems Command, St. Louis, Missouri, April 1975.

FLIGHT TEST

CONFIGURATIONS

The flight test phases of this program were conducted on an Army-furnished UH-1H helicopter, Serial No. 66-1093. The UH-1H helicopter has a single, two-bladed, semi-rigid, teetering, 48-foot-diameter main rotor that operates at a 100-percent rotor speed of 324 rpm. The helicopter used in this flight test program is shown in Figure 9. The standard UH-1H helicopter has a rotor isolation system as shown schematically in Figure 10. This is a five-point mounting system designed to isolate the fuselage from the inplane, two-per-rev vibratory forces of the main rotor. To achieve this isolation, each of the five tubular elastomeric mounts, four of which are located at the corners of the transmission and the fifth located on the aft section of the transmission at Butt Line 0, has a low vertical spring rate to give a low natural frequency in pitch and roll. Each of the four transmission mounts has a high inplane spring rate to react torque and to insure engine and rotor torsional compatibility. The fifth mount is pinned so that it does not react torque. The UH-1H has a rigid lift link to react the vertical load; therefore, no vertical isolation is achieved.

The baseline flight vibration data was obtained on the standard vehicle at the Experimental Flight Test Facilities of Kaman Aerospace Corporation by Kaman personnel between 3 October 1972 and 25 October 1972, involving seven flights covering 7.4 hours of rotor time. The complete description of this flight test phase and tabular documentation is given in Reference 12.

In order to insure minimum structural modifications and the integrity of similar load paths in the DAVI-modified UH-1H helicopter, the DAVI isolators were located at the same mounting points as in the standard system. Figure 11 shows a schematic of the DAVI system. In comparing the DAVI system with the standard system, it is seen that:

- (1) The standard four transmission mounts have been replaced with four two-dimensional DAVI mounts.
- (2) The standard fifth mount has been eliminated.
- (3) The standard lift link has been replaced by a unidirectional DAVI.

¹² Bill and Maier, UH-1H HELICOPTER, BASELINE FLIGHT VIBRATION - SUMMARY OF VIBRATION DATA, Kaman Report SMR-1006, Kaman Aerospace Corporation, Bloomfield, CT, October 1972.



Figure 9. UH-1H Helicopter, Serial Number 66-1093

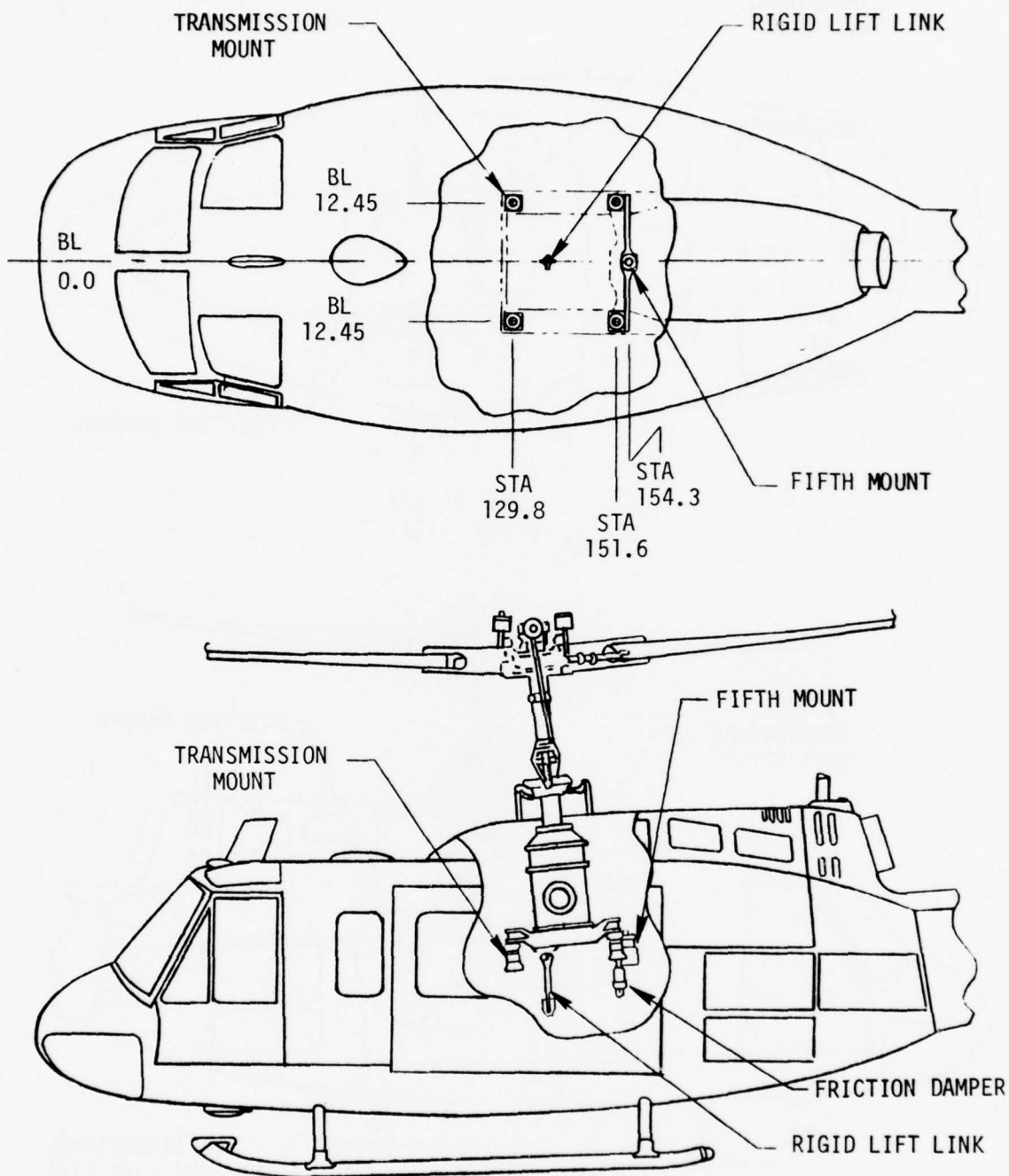

Figure 10. Schematic of the Standard UH-1H Isolation System

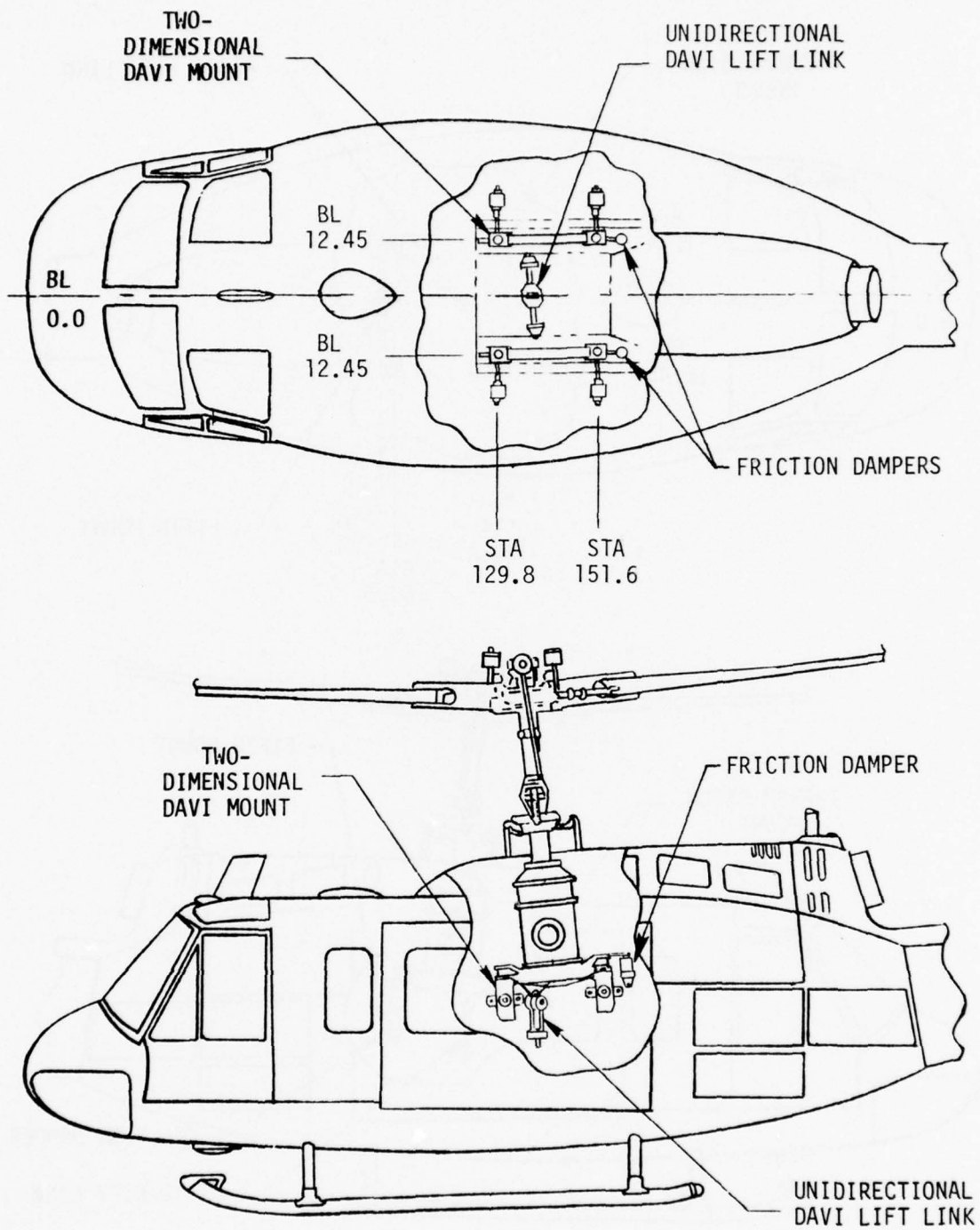

Figure 11. Schematic of the UH-1H DAVI Isolation System

Thus, in this DAVI system, antiresonant isolation is obtained in the vertical, longitudinal, and pitching directions; conventional isolation is obtained in the lateral direction; and a combination of conventional and antiresonant isolation is obtained in the rolling direction.

To achieve dynamic characteristics similar to those in the standard vehicle, the vertical and longitudinal spring rates of the transmission DAVIs were designed to give the same low natural frequencies in pitch and roll as the standard UH-1H. In the lateral direction, the spring rates were designed to give torsional restraints similar to those of the standard system. The unidirectional DAVI lift link, which is pinned at the transmission and fuselage, was designed to provide an overall system vertical spring rate to minimize relative deflection and engine drive shaft misalignment.

The buildup to the required flight conditions and the flight vibration data were obtained on this DAVI-modified UH-1H helicopter at the Experimental Flight Test Facilities of Kaman Aerospace Corporation by Kaman personnel between 3 July 1975 and 15 October 1975 including 34 flights covering 21.9 hours of rotor time. The complete description of this flight test phase and the tabular documentation of data are given in Reference 13.

CONDITIONS

Table 1 gives the flight test conditions of the DAVI-modified UH-1H helicopter. These flight conditions include the ground rev-up and envelope expansion to insure the safety of flight. All flight conditions, except ground rev-up, were done at 100-percent rotor rpm and center of gravity of 138 inches.

In Table 1, the envelope expansions (A through M) for the 8250-pound and 9500-pound gross weights were conducted with the standard friction dampers in the isolation system. Conditions N through U for the DAVI-modified vehicle were flown without the friction dampers, which was the anticipated final configuration based upon shake-test requirements. Additional flight conditions (J, N, and P) on the DAVI-modified vehicle were flown with a main rotor obtained from UH-1H helicopter Serial No. 68-14601 to evaluate the effects of a different main rotor on in-flight vibration levels.

¹³ Bill, UH-1H DAVI MODIFIED HELICOPTER, FLIGHT VIBRATION - SUMMARY OF VIBRATION DATA, Kaman Report SMR-1053, Kaman Aerospace Corporation, Bloomfield, CT, September 1975.

TABLE 1. FLIGHT TEST CONDITIONS

Test Ident	GW (lb)	Alt (ft)	Condition	Calibrated Airspeed (knots)
A	8250/9500	0	Rotor run up	Run-up to engine idle, 180 rotor rpm
B	8250/9500	0	Slow increase in rotor rpm to 294	Controls neutral, collective as required
C	8250/9500	0	Slow increase to flight rpm	Controls neutral, collective as required
D	8250/9500	0	Series of small, slow, cyclic inputs, collective as required	
E	8250/9500	0	Series of small, fixed amount of cyclic inputs, collective as required	
F	8250/9500	0	Ground stability check	
G	8250/9500	IGE/OGE	Hover	
H	8250/9500	IGE/OGE	Control inputs in hover	
I	8250/9500	500-1000	Envelope expansion	0-70
J	8250/9500	500-1000	Climbs and descends to maximum rate	70
K	8250/9500	500-1000	Autorotation and power recoveries	60-70
L	8250/9500	500-1000	Envelope expansion	0-116
M	8250/9500	2000	15, 30, 45 deg banked coordinated turns (R&L)	50 and 90
N	8250/9500	2000	Level flight	0, 20, 30, 40, 50, 60, 70, 80, 90, 100, 105, 110, 116
O	8250/9500	2000	Blade out-of-track level flight	100
P*	8250/9500	2000	45-deg left and 30-deg right coordinated turn	50 and 90
Q*	8250/9500	2000	30-40-deg/sec left turn	Hover
R*	9500	2000	Level flight	0, 20, 30, 40, 50, 60, 70, 80, 90, 100, 105, 110, 116
S*	9500	2000	Blade out-of-track	100
T*	9500	2000	45-deg left and 30-deg right coordinated turn	50 and 90
U*	9500	2000	30-40 deg/sec left turn	Hover

* Standard UH-1H and DAVI Modified UH-1H Test Conditions.

INSTRUMENTATION

Table 2 gives the instrumentation used in the flight test programs for both the standard and DAVI-modified UH-1H helicopter. Common instrumentation was used in both phases except where noted, where additional instrumentation was used on the DAVI-modified vehicle. Figure 12 shows the location of the fuselage accelerometers. It is these accelerometers that are used to determine the vibratory responses of the fuselage and that allow the comparison of the responses to determine the vibration reduction achieved with the DAVI isolation system.

Figure 13 shows the location of the nine linear potentiometers. The deflections obtained from these potentiometers were used to determine the relative deflection and rotation of the transmission with respect to the fuselage.

Figure 14 shows the location of the twelve strain gages on the lower transmission support-plate assembly. These strain gages were not calibrated but only used to get comparative strain measurements in the lower transmission support plate between the standard and the DAVI-modified UH-1H helicopter.

Figure 15 shows the six self-generating high-frequency accelerometers installed mutually perpendicular to each other, three on the engine inlet and three on the diffuser flange, for recording the engine response. These responses were recorded on a government-furnished, on-board Genisco Model 10-276 wide-band magnetic tape recorder. The data was reduced by Eustis Directorate.

Figure 16 shows the strain gage locations on the main rotor and shaft. The main rotor flatwise bending moments and drag-brace loads were recorded to get the effects of the DAVI isolation system on the rotor parameters as compared to the standard system, since the change in the isolation system could change the rotor impedance. Main rotor shaft torque was also recorded, primarily to determine the vibratory torque characteristics and the torsion compatibility of the systems.

Figure 17 shows the control position transducers. The control position and ship attitude were recorded to determine trim and to obtain the effects of the DAVI isolation system on trim.

The additional instrumentation incorporated in the DAVI-modified vehicle was primarily to monitor control loads in the modified control system and to monitor and determine engine coupling misalignment.

TABLE 2. INSTRUMENTATION

Fuselage Accelerometers (Figure 12)

1. Nose vertical, station 0.
2. Nose lateral, station 0.
3. Nose longitudinal, station 0.
4. Pilots area vertical, station 55.
5. Pilots area lateral, station 55.
6. Pilots area longitudinal, station 55.
7. Copilots area vertical, station 55.
8. Copilots area lateral, station 55.
9. Copilots area longitudinal, station 55.
10. Upper transmission housing vertical, station 140.
11. Upper transmission housing lateral, station 140.
12. Upper transmission housing longitudinal, station 140.
13. Center of gravity vertical, station 138.
14. Center of gravity lateral, station 138.
15. Center of gravity longitudinal, station 138.
16. Tail pylon vertical, station 485.
17. Tail pylon lateral, station 485.
18. Tail pylon longitudinal, station 485.

Transmission Linear Potentiometers (Figure 13)

1. Left forward transmission mount vertical.
2. Left forward transmission mount longitudinal.
3. Right forward transmission mount vertical.
4. Right forward transmission mount lateral.
5. Right forward transmission mount longitudinal.
6. Left aft transmission mount vertical.
7. Left aft transmission mount lateral.
8. Left aft transmission mount longitudinal.
9. Right aft transmission mount vertical.

Transmission Case Strain Gages (Figure 14)

- | | | |
|-----|---------|---|
| 1. | Gage 1 | Transmission support plate right aft ear. |
| 2. | Gage 2 | Transmission support plate right aft ear. |
| 3. | Gage 3 | Transmission support plate right aft ear. |
| 4. | Gage 4 | Transmission support plate right aft ear. |
| 5. | Gage 5 | Transmission support plate right aft ear. |
| 6. | Gage 6 | Transmission support plate right aft ear. |
| 7. | Gage 7 | Transmission support plate right forward ear. |
| 8. | Gage 8 | Transmission support plate right forward ear. |
| 9. | Gage 9 | Transmission support plate left forward ear. |
| 10. | Gage 10 | Transmission support plate left forward ear. |

TABLE 2 (Continued)

Transmission Case Strain Gages

11. Gage 11 Transmission support plate left aft ear.
12. Gage 12 Transmission support plate left aft ear.

Engine Accelerometers (Figure 15)

1. Inlet housing vertical.
2. Inlet housing lateral.
3. Inlet housing longitudinal.
4. Diffuser housing vertical.
5. Diffuser housing lateral.
6. Diffuser housing longitudinal.

Main Rotor and Shaft Parameters (Figure 16)

1. Main rotor shaft torque.
2. Main rotor drag brace.
3. Main rotor flatwise bending.

Control and Vehicle Position Indicators (Figure 17)

1. Collective stick.
2. Longitudinal cyclic stick.
3. Lateral cyclic stick.
4. Directional Pedal.
5. Pitch attitude gyro.
6. Roll attitude gyro.
7. Pitch attitude pendulum.

Additional Instrumentation for the DAVI Modified Vehicle

1. Collective control compensating rod strain gage.
2. Left-hand cyclic control compensating rod strain gage.
3. Right-hand cyclic control compensating rod strain gage.
4. Main rotor teeter angle.
5. Engine-transmission coupling vertical potentiometer.
6. Engine-transmission coupling lateral potentiometer.
7. 150 to 300°F temperature tapes on main driveshaft at engine output coupling and main transmission input coupling.
8. 150 to 300°F temperature tapes on tail rotor driveshaft coupling at main transmission.

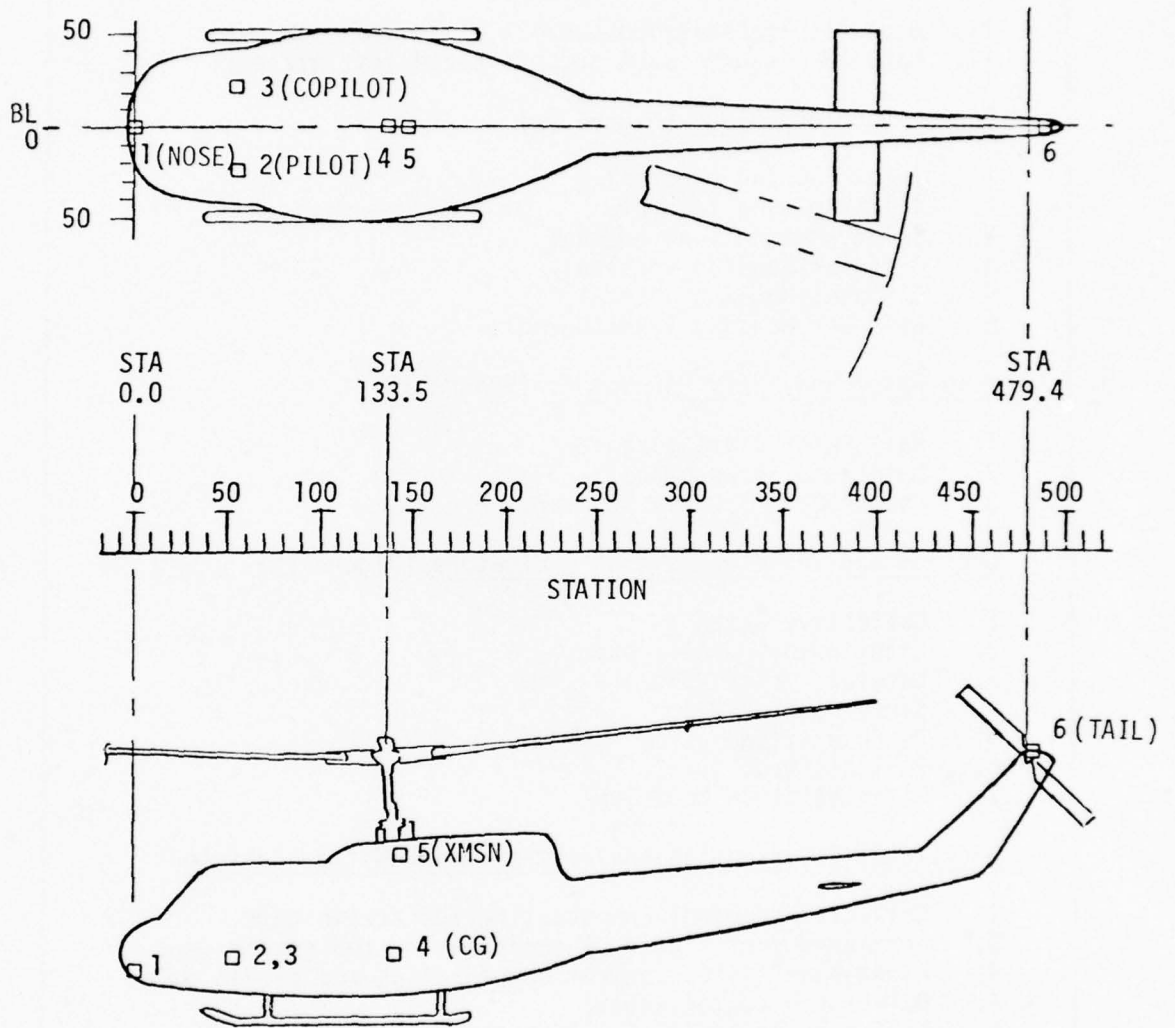

Figure 12. Accelerometer Locations

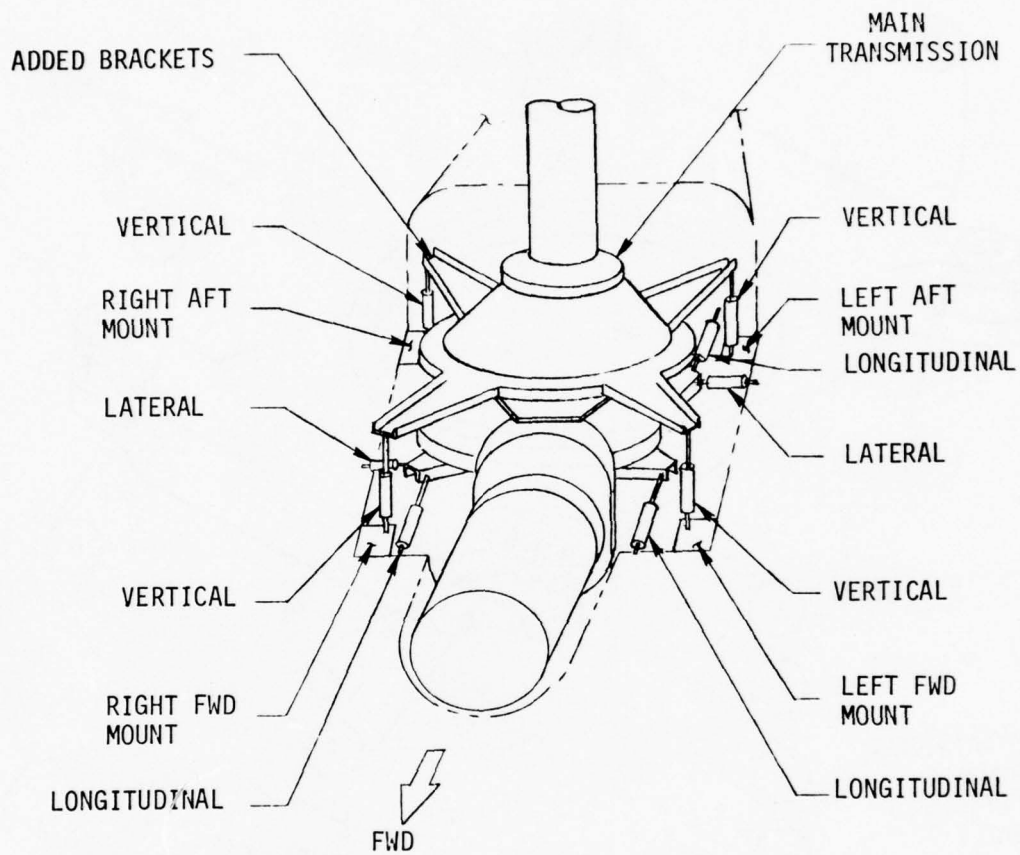

Figure 13. Linear Potentiometer Locations -
Main Transmission Mount
Displacement

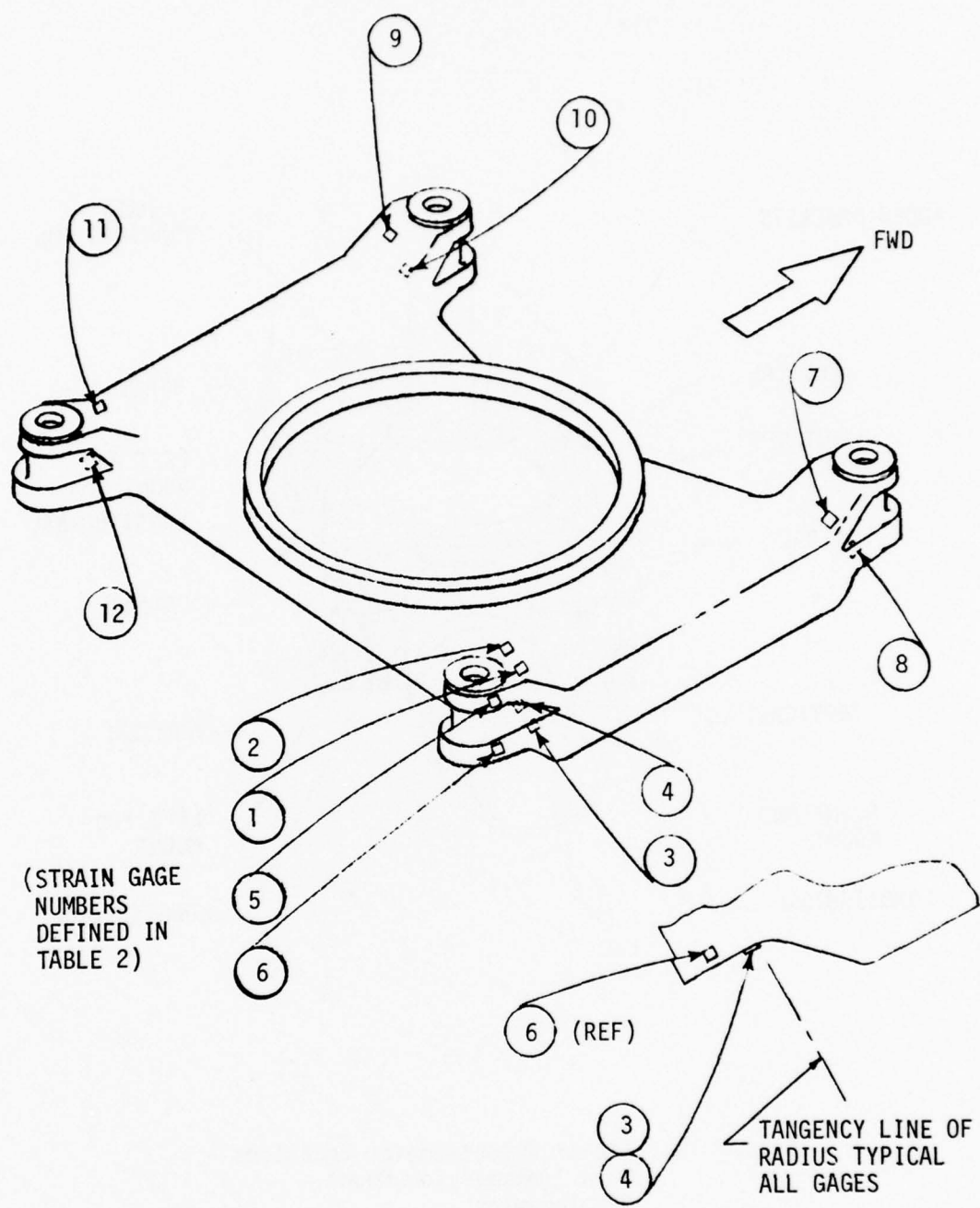

Figure 14. Strain Gage Locations - Lower Transmission Support Plate Assembly

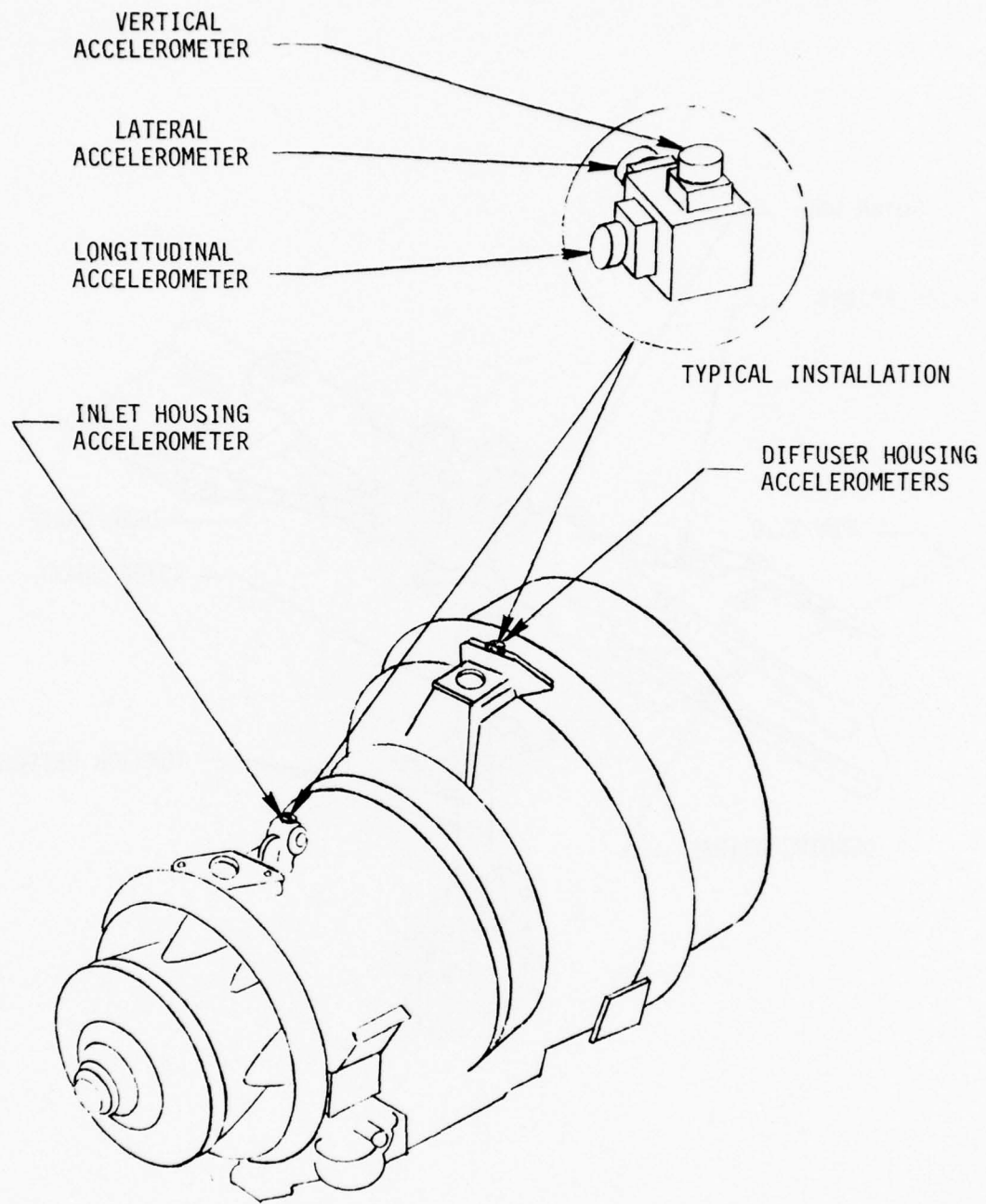

Figure 15. Accelerometer Installation - Engine

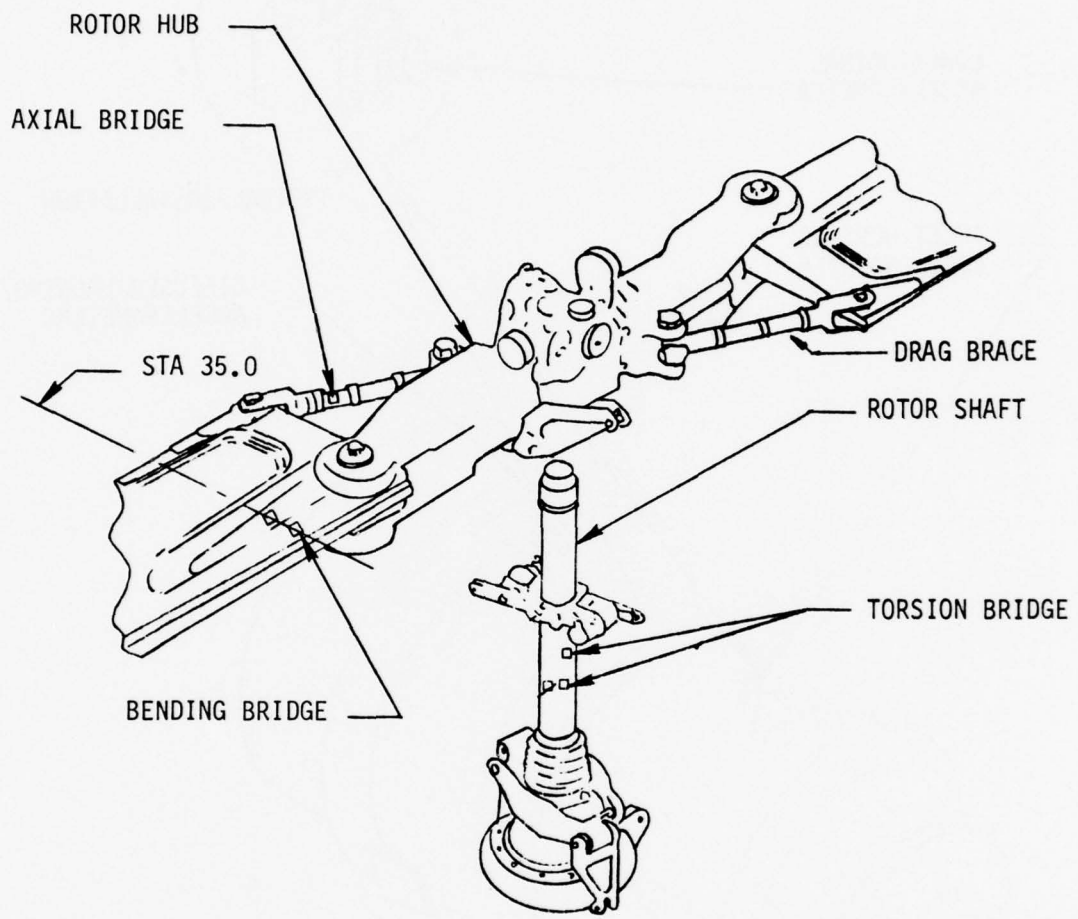

Figure 16. Strain Gage Installation - Rotor Blades and Shaft

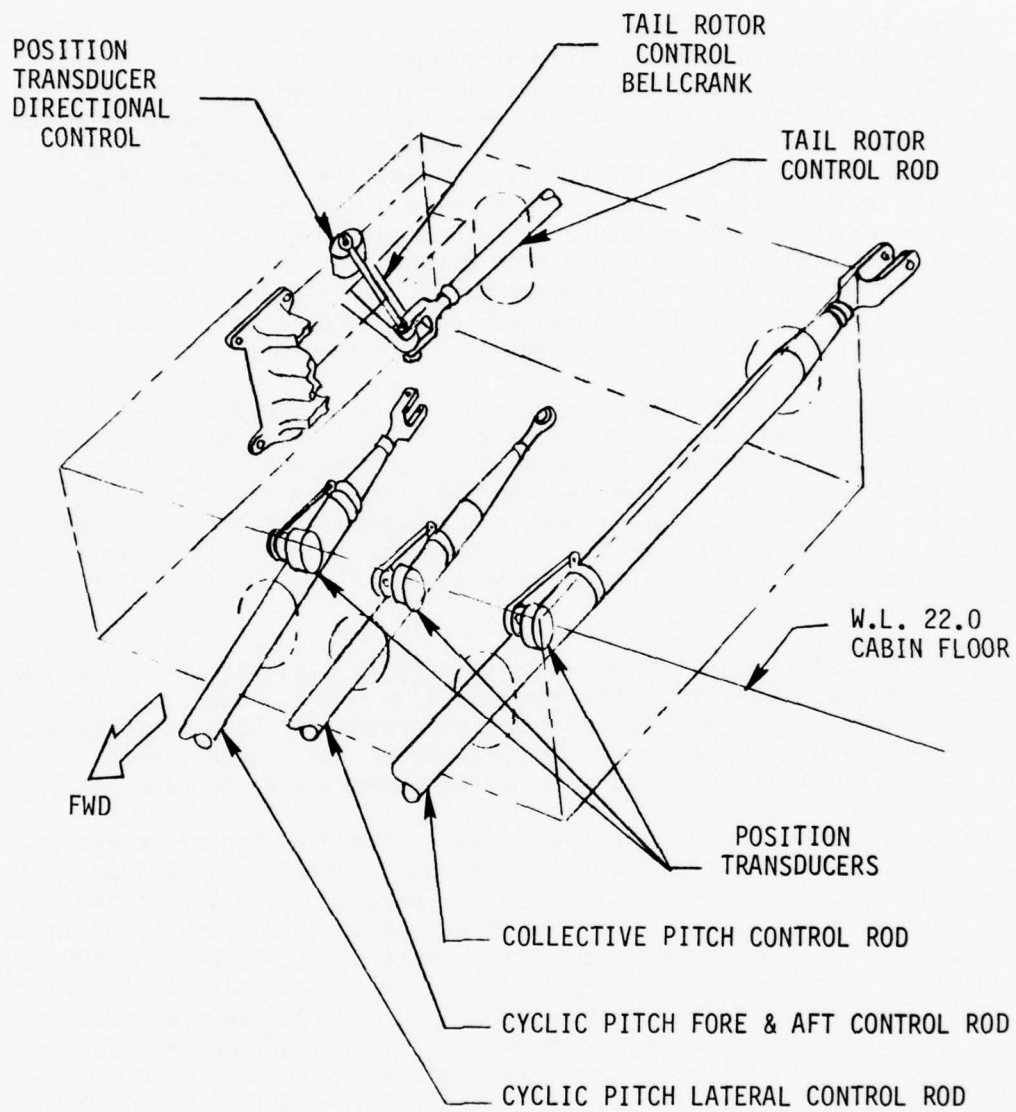

Figure 17. Position Transducers - Pilot's and Copilot's Controls

RESULTS

One-Per-Rev Airframe Response

Figures 18 through 25 show the one-per-rev responses and effectivities of the standard and DAVI isolated fuselages for straight and level flight. Figures 18 and 19 show the one-per-rev vertical response for the 8250- and 9500-pound vehicles, respectively. It is seen from these curves that the major vertical one-per-rev response is at the tail, which approaches .15g at 100 knots, and that the 9500-pound DAVI-modified vehicle at the higher speed has a lower response than the standard vehicle. The response at the center of gravity (cg) is essentially negligible for both configurations. In the forward sections of the vehicles, the vertical response of the standard vehicle is approximately .05g at 100 knots, and the DAVI-modified vehicle has a lower response at the higher speeds than the standard vehicle.

Figures 20 and 21 show the one-per-rev lateral responses for the 8250- and 9500-pound vehicles, respectively. It is seen from these curves that the largest fuselage responses occur at the nose and tail areas of the vehicles. It is further seen that both the standard and DAVI-modified UH-1H have similar response characteristics in these areas. At the pilot and copilot seats, the vibration level is approximately .05g at the higher speed for both the standard and DAVI-modified configurations.

Figures 22 and 23 show the one-per-rev longitudinal responses for the 8250- and 9500-pound vehicles, respectively. It is seen from these figures that, except at the tail, the responses for both configurations are negligible. At the tail, the response at the higher speeds is .05g to .075g with both configurations having essentially the same response.

In order to determine the effectiveness of the DAVI isolation system, the response at each station of the standard vehicle was divided by the response of the DAVI-modified vehicle. Therefore, the larger the ratio, the better the isolation. Figures 24 and 25 show the results of these calculations. These results are the average of the 8250- and 9500-pound vehicles. It is seen from these effectivity curves that, in the vertical direction, the DAVI system had a lower one-per-rev response in the low-speed regime, a higher response at mid-speed, and a lower response at the high-speed conditions than the standard vehicle. In the lateral direction, it is seen that the DAVI-modified system had a lower response in the low-speed regime, a higher response at mid-speed, and essentially the same response at high speed as the standard vehicle.

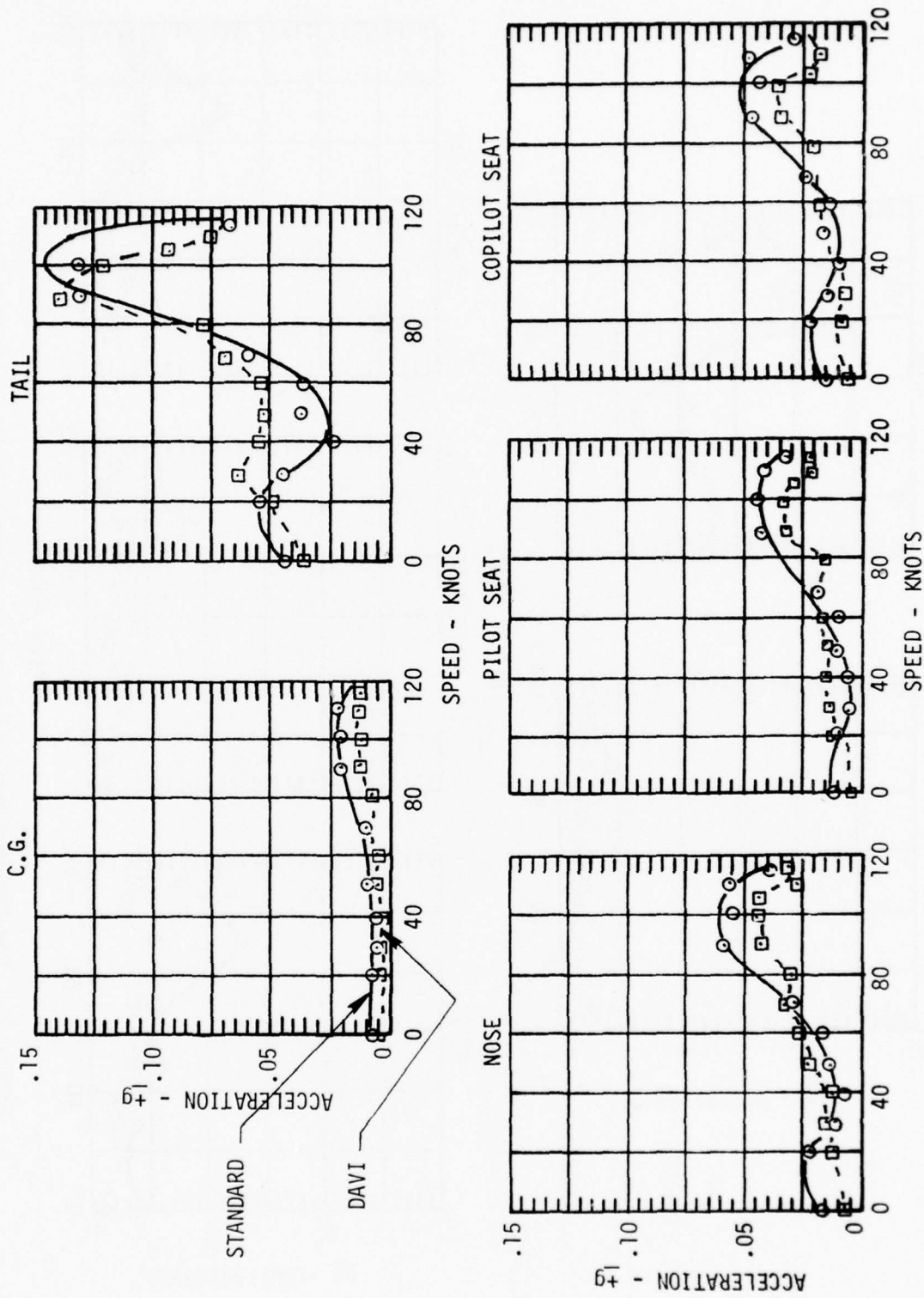

Figure 18. One-Per-Rev Vertical Response of the 8250-Pound UH-1H Helicopter

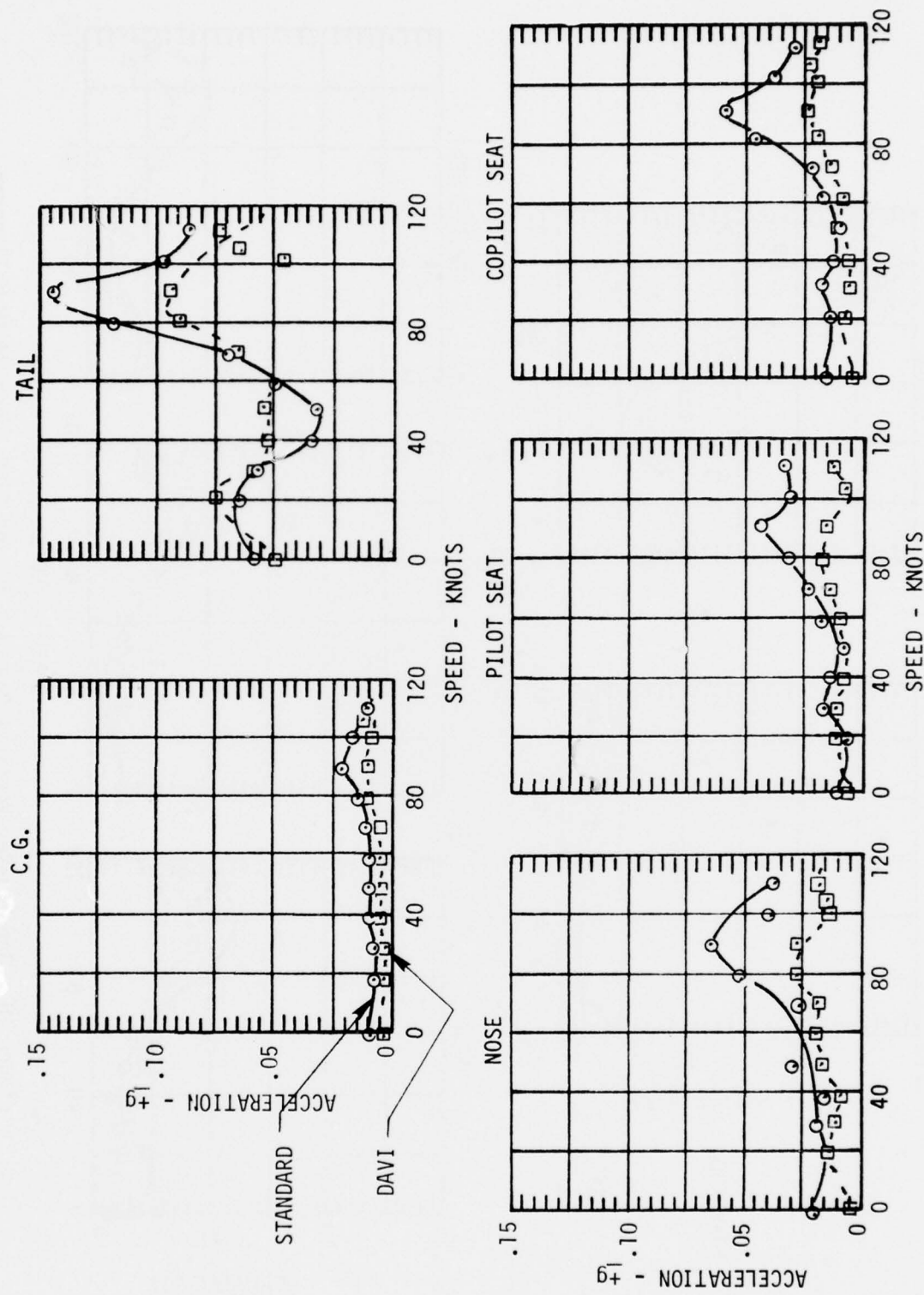

Figure 19. One-Per-Rev Vertical Response of the 9500-Pound UH-1H Helicopter

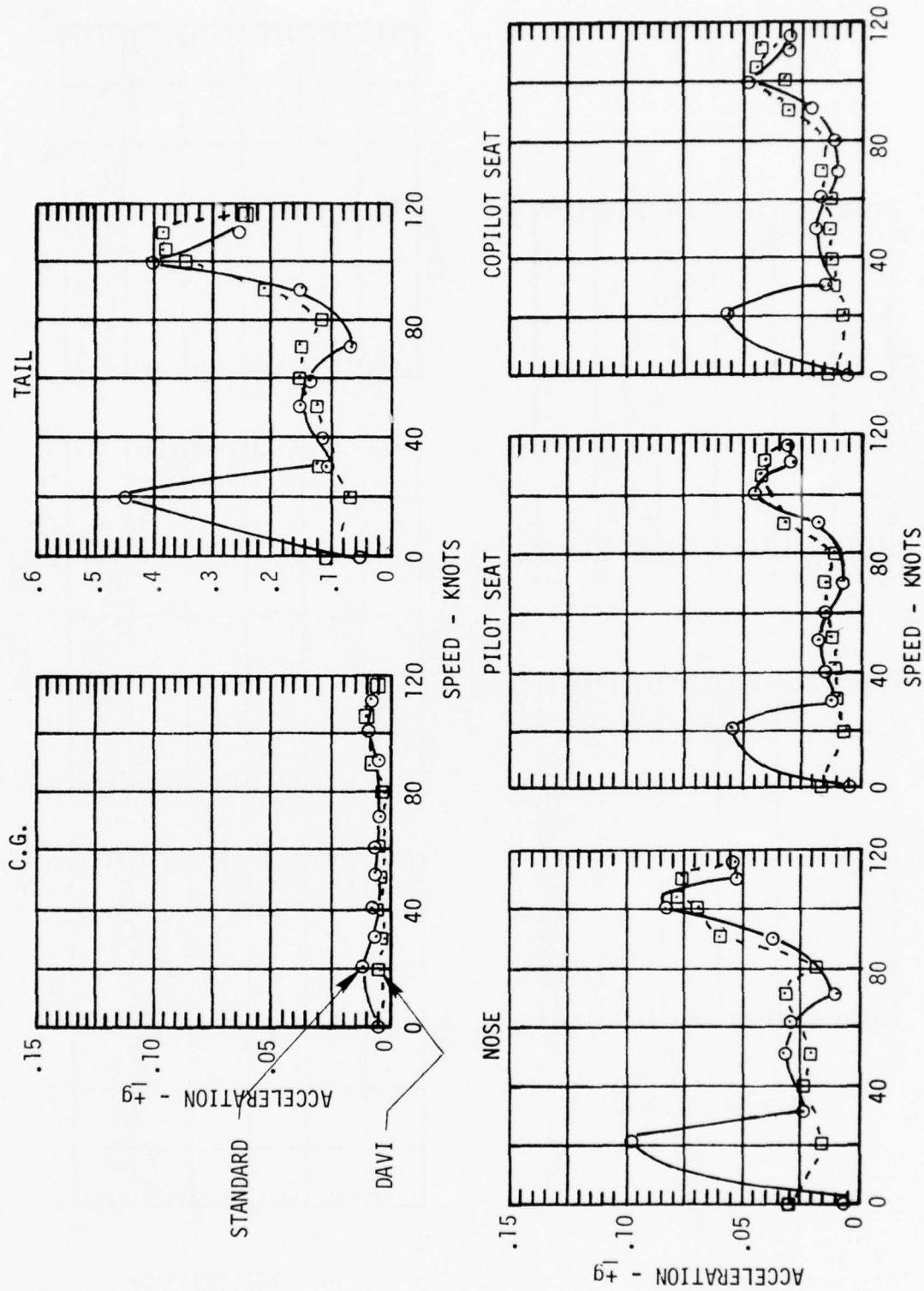

Figure 20. One-Per-Rev Lateral Response of the 8250-Pound UH-1H Helicopter

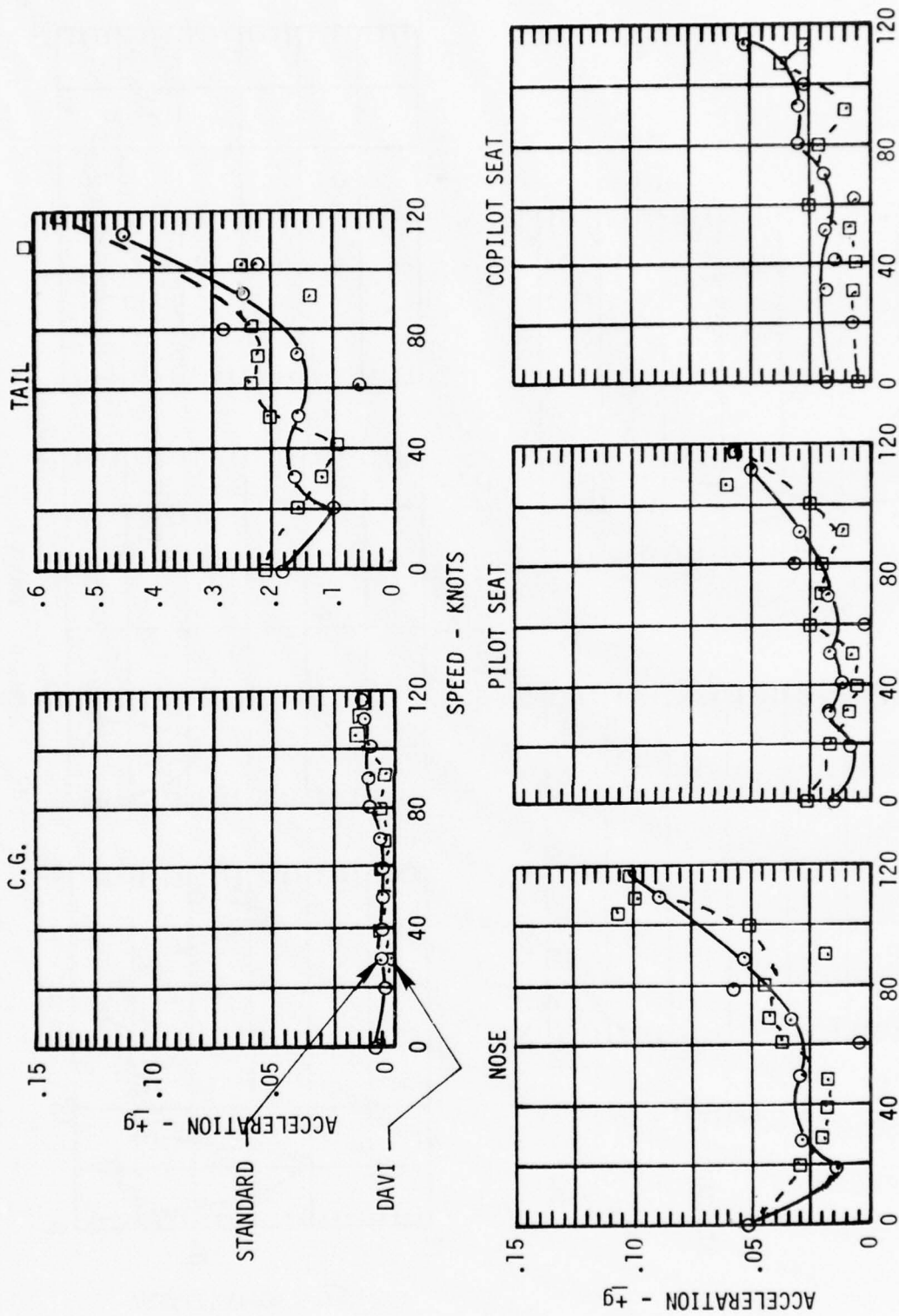

Figure 21. One-Per-Rev Lateral Response of the 9500-Pound UH-1H Helicopter

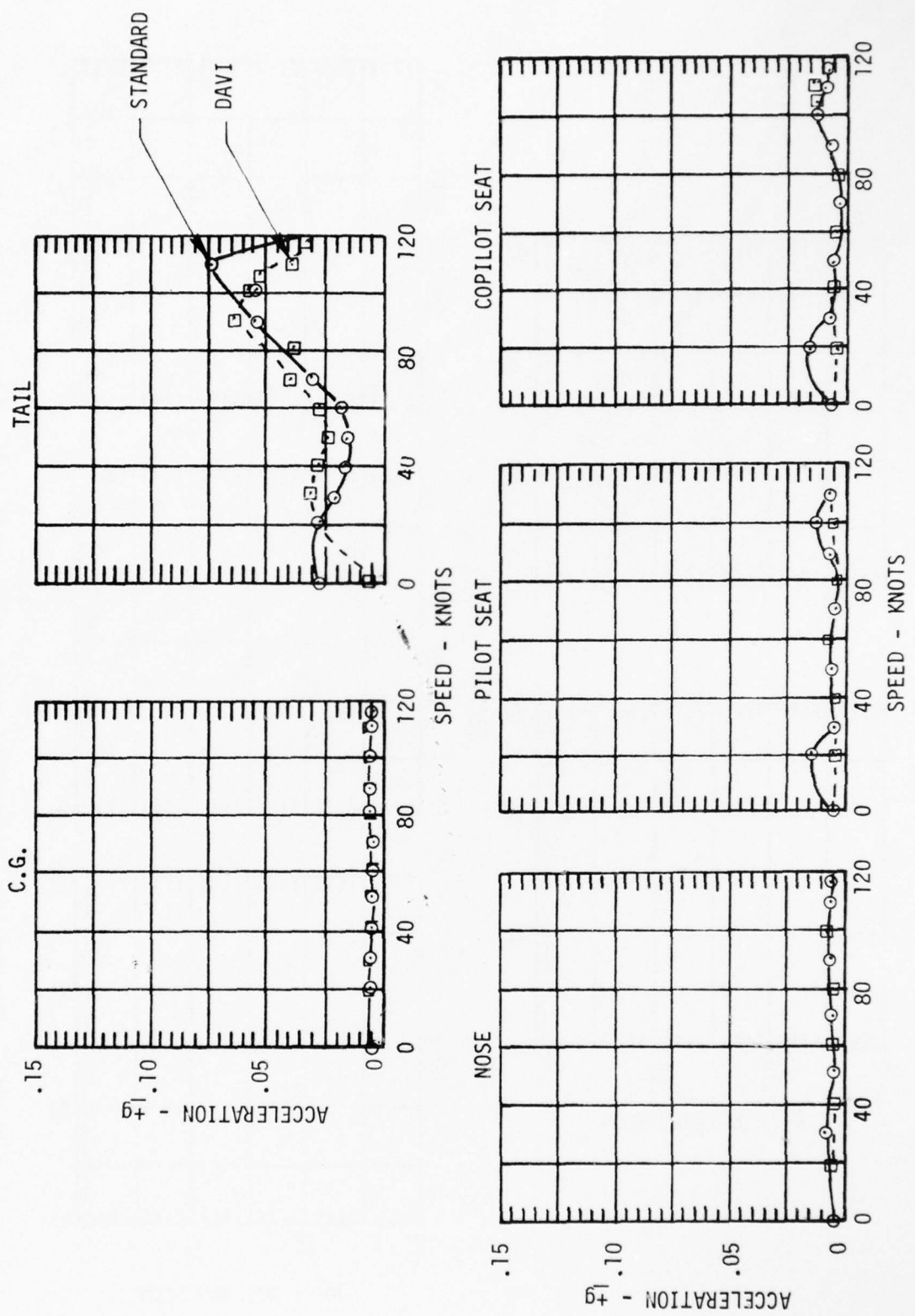

Figure 22. One-Per-Rev Longitudinal Response of the 8250-Pound UH-1H Helicopter

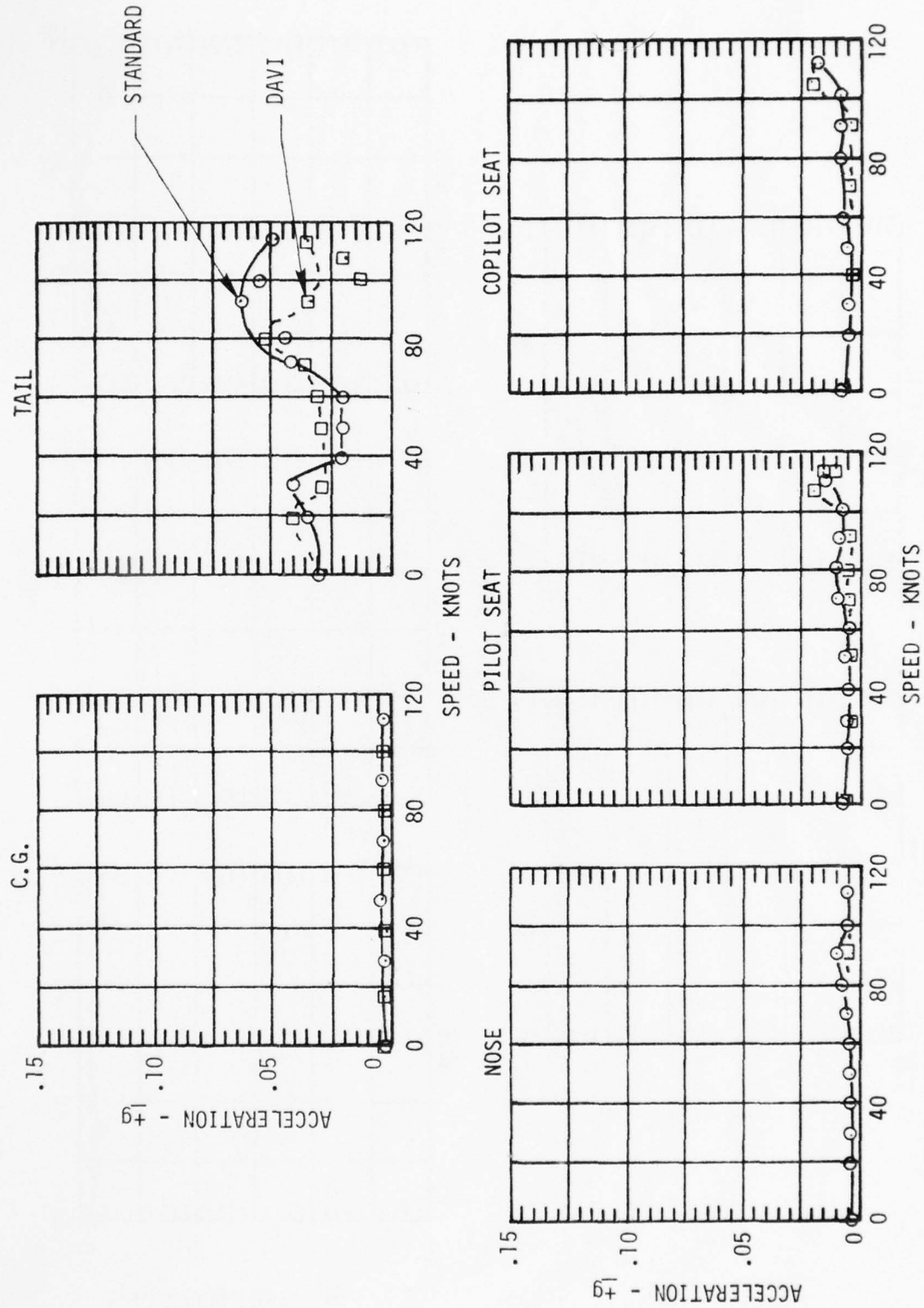

Figure 23. One-Per-Rev Longitudinal Response of the 9500-Pound UH-1H Helicopter

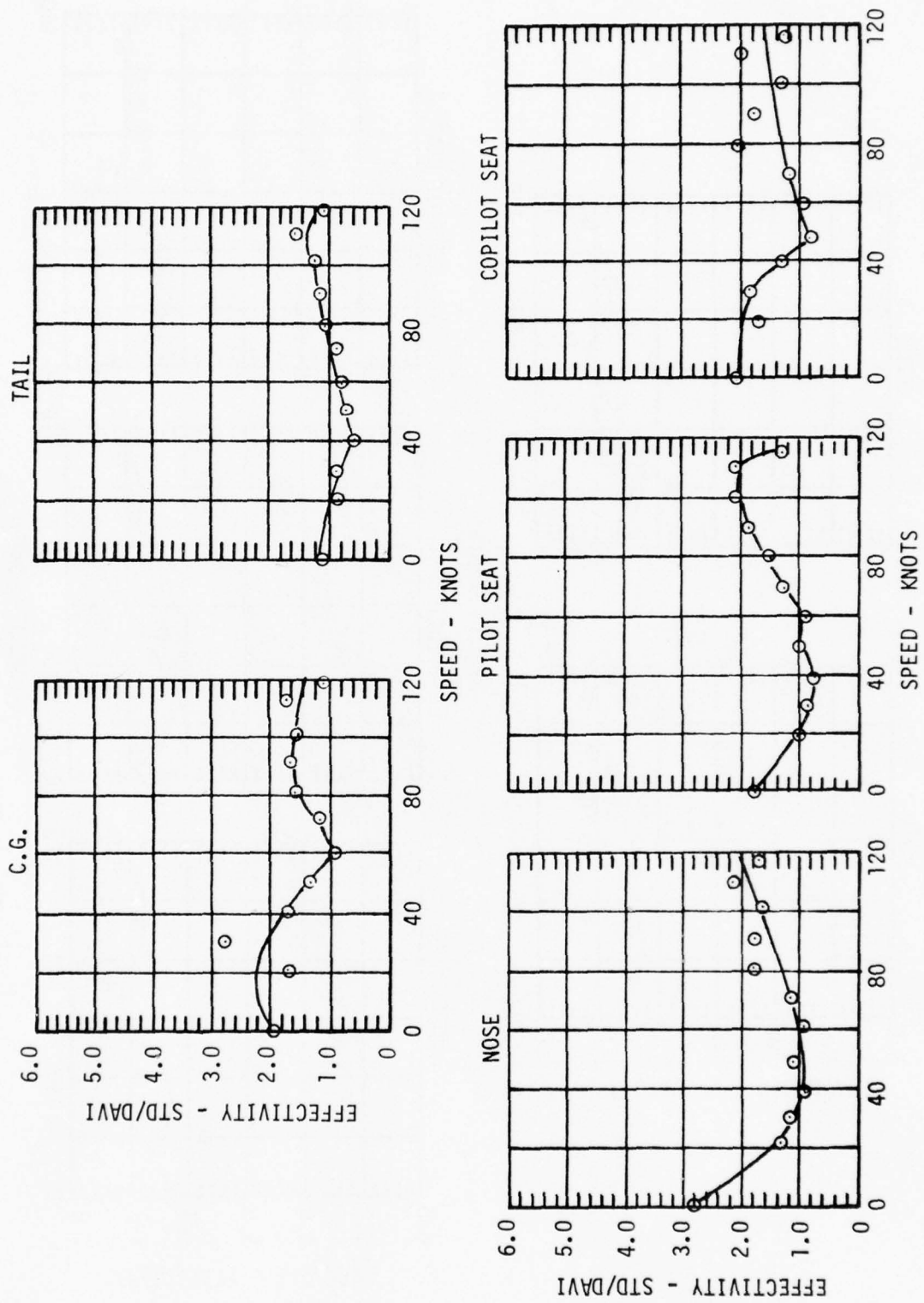

Figure 24. One-Per-Rev Vertical Effectivity

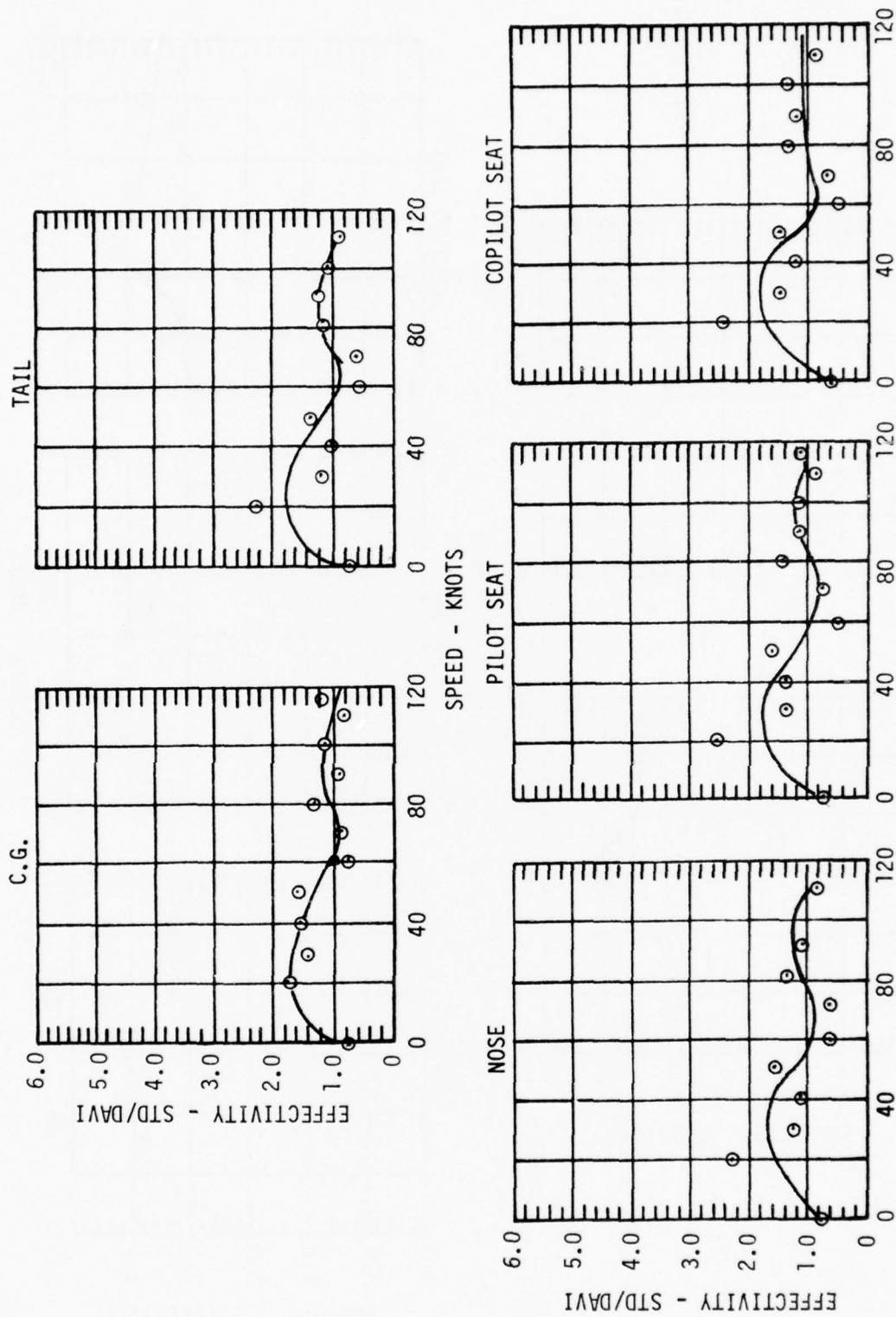

Figure 25. One-Per-Rev Lateral Effectivity

Tables 3 and 4 show the one-per-rev vibratory responses of the isolated fuselages of the 8250-pound and 9500-pound test vehicles, respectively, for the steady-state turn maneuvers. It is seen from Table 3 that the one-per-rev response of the fuselage for the DAVI-isolated 8250-pound vehicle is lower in all directions than the standard isolated vehicle for all of the steady-state maneuvers done.

In Table 4 it is seen that, for the 50-knot left turn and the 90-knot right turn, the DAVI-isolated vehicle has lower one-per-rev responses in most all directions and locations than the standard vehicle. For the hover right turn, the DAVI-isolated vehicle has the same or lower responses in the vertical and longitudinal directions. However, for the hover right turn, the DAVI-isolated vehicle has two to three times the lateral one-per-rev responses of the standard vehicle. This was the only flight condition, including level flight, where the DAVI-isolated vehicle had a substantially higher one-per-rev response than the standard vehicle. This difference can be attributed to different wind conditions and/or the difficulty of repeating a given flight condition, especially a maneuver.

Since the data show that the DAVI-modified vehicle has lower responses for one-per-rev excitation throughout most of the flight conditions, including steady-state maneuvers, it could be concluded that the DAVI-modified vehicle is less susceptible to one-per-rev than the standard system. However, the rotor system was retracked when reinstalled on the DAVI-modified vehicle; therefore, it is concluded that the DAVI-modified vehicle is no more susceptible to rotor tracking than the standard system.

Two-Per-Rev Airframe Response

Figures 26 through 33 show the two-per-rev responses and effectivities of the standard and the DAVI-modified UH-1H helicopter isolated fuselages for straight and level flight. Figures 26 and 27 show the two-per-rev vertical responses of the 8250- and 9500-pound vehicles, respectively. It is seen from these figures that a major reduction of the two-per-rev vertical response was achieved with the DAVI-modified vehicle as compared to the standard vehicle. It was expected that the greatest reductions would occur in the two-per-rev vertical response of the vehicle since the antiresonant frequency of the DAVI was tuned to this predominant two-per-rev excitation of the rotor. It is further seen that the greatest reduction occurred in the forward section of the vehicle; that is, the nose, pilot, and copilot areas. At the low transition speed, essentially no build-up of vibration occurred in the DAVI-isolated vehicle, the maximum vibration level being .05g in the nose, .03g in the pilot seat area, and .06g in the copilot seat area. At the higher forward speed, the vibration level of the DAVI-modified vehicle increased but was approximately one-half the level of the standard vehicle. It is also seen that the minimum vibration level of the forward section of the standard vehicle occurs at approximately 50 knots, whereas the same level on the DAVI-modified vehicle occurs at approximately 100 knots.

TABLE 3. ONE-PER-REV VIBRATORY RESPONSE OF THE 8250-POUND TEST VEHICLE FOR STEADY-STATE TURNS

Speed (Knots)	Trnsdcr Dir	Transducer Location and Magnitude - $\pm g$														
		Nose			Pilot Seat			Copilot Seat			CG			Tail		
		Std	DAVI	E*	Std	DAVI	E*	Std	DAVI	E*	Std	DAVI	E*	Std	DAVI	E*
0	VT	.022	.016	1.38	.017	.012	1.42	.019	.012	1.58	.012	.006	2.00	.064	.034	1.88
	LT	.044	.043	1.02	.025	.021	1.19	.026	.021	1.23	.008	.006	1.33	.122	.165	.73
	LONG	.010	.004	2.5	.006	.007	.86	.010	.007	1.43	.005	.003	1.67	.056	.029	1.93
50	VT	.047	.022	2.13	.003	.015	2.20	.040	.016	2.50	.016	.004	4.00	.114	.064	1.78
	LT	.025	.026	.96	.014	.013	1.07	.014	.013	1.08	.005	.003	1.67	.142	.141	1.01
	LONG	.006	.004	1.5	.004	.005	.80	.006	.005	1.20	.004	.002	2.00	.054	.030	1.8
50	VT	.042	.032	1.31	.029	.027	1.07	.036	.021	1.71	.013	.005	2.60	.076	.109	.70
	LT	.048	.020	2.4	.027	.010	2.7	.028	.012	2.33	.006	.005	1.20	.212	.100	2.12
	LONG	.005	.005	1.00	.007	.002	3.5	.009	.005	1.80	.004	.003	1.33	.055	.051	1.08
90	VT	.047	.025	1.88	.039	.016	2.44	.040	.024	1.67	.018	.010	1.80	.110	.086	1.29
	LT	.037	.025	1.48	.021	.014	1.50	.020	.011	1.62	.007	.004	1.75	.183	.125	1.48
	LONG	.006	.005	1.20*	.006	.005	1.20	.003	.004	2.00	.004	.002	2.00	.052	.031	1.68
90	VT	.043	.024	1.79	.034	.014	2.43	.037	.023	1.61	.017	.010	1.70	.090	.081	1.11
	LT	.054	.026	2.07	.029	.014	2.07	.030	.016	1.88	.007	.004	1.75	.281	.139	2.02
	LONG	.004	.004	1.00	.009	.005	1.80	.009	.006	1.50	.003	.002	1.50	.044	.042	1.05

* EFFECTIVITY - The standard vehicle response divided by the DAVI-modified vehicle response.

TABLE 4. ONE-PER-REV VIBRATORY RESPONSE OF THE 9500-POUND TEST VEHICLE FOR STEADY-STATE TURNS

Speed (Knots)	Dir	Trnsdcr Dir	Transducer Location and Magnitude - +g														
			Nose			Pilot Seat			Copilot Seat			CG			Tail		
			Std	DAVI	E*	Std	DAVI	E*	Std	DAVI	E*	Std	DAVI	E*	Std	DAVI	E*
0	RT	VT	.042	.018	2.33	.028	.026	1.07	.033	.005	6.6	.010	.004	2.5	.115	.114	1.01
		LT	.046	.117	.39	.027	.061	.44	.028	.065	.43	.012	.018	.67	.123	.359	.34
		LONG	.010	.006	1.66	.008	.015	.53	.011	.019	.58	.005	.003	1.67	.139	.085	1.63
50	RT	VT	.027			.024			.021			.006			.096		
		LT	.040			.021			.022			.006			.196		
		LONG	.005			.005			.007			.002			.057		
50	LFT	VT	.033	.021	1.57	.023	.020	1.15	.032	.013	2.46	.010	.004	2.5	.090	.089	1.01
		LT	.037	.025	1.48	.022	.013	1.69	.022	.013	1.69	.006	.007	.86	.169	.114	1.48
		LONG	.005	.004	1.25	.006	.003	2.00	.009	.006	1.50	.003	.003	1.00	.052	.045	1.16
90	RT	VT	.040	.025	1.60	.033	.024	1.38	.029	.018	1.61	.013	.008	1.63	.080	.095	.84
		LT	.057	.037	1.54	.034	.019	1.79	.034	.021	1.62	.007	.006	1.17	.254	.190	1.49
		LONG	.004	.004	1.00	.009	.010	.90	.012	.007	1.71	.003	.002	1.50	.040	.047	.85
90	LFT	VT	.025			.020			.020			.005			.084		
		LT	.025			.015			.016			.002			.139		
		LONG	.003			.004			.007			.002			.036		

* EFFECTIVITY - The standard vehicle response divided by the DAVI-modified vehicle response.

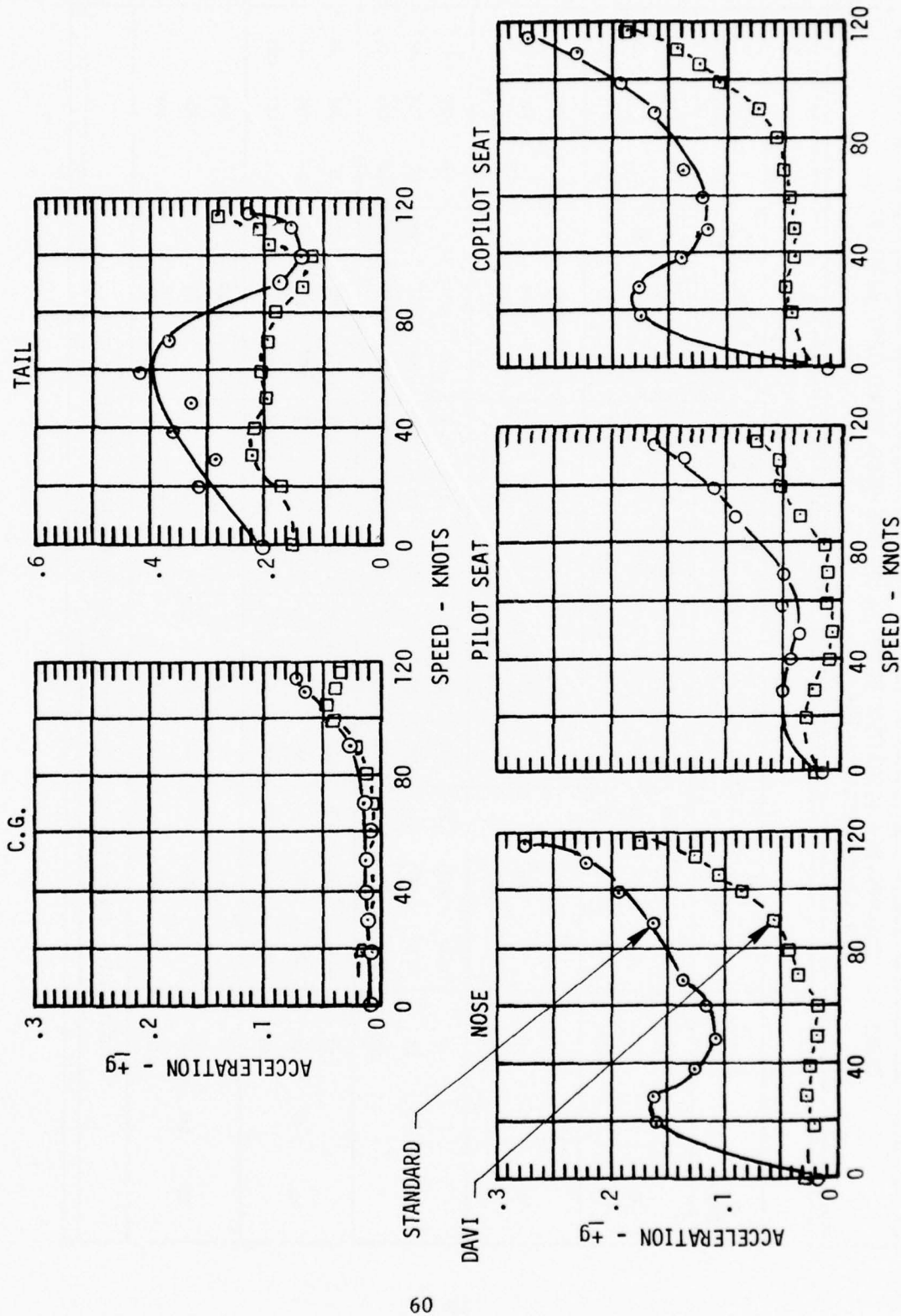

Figure 26. Two-Per-Rev Vertical Response of the 8250-Pound UH-1H Helicopter

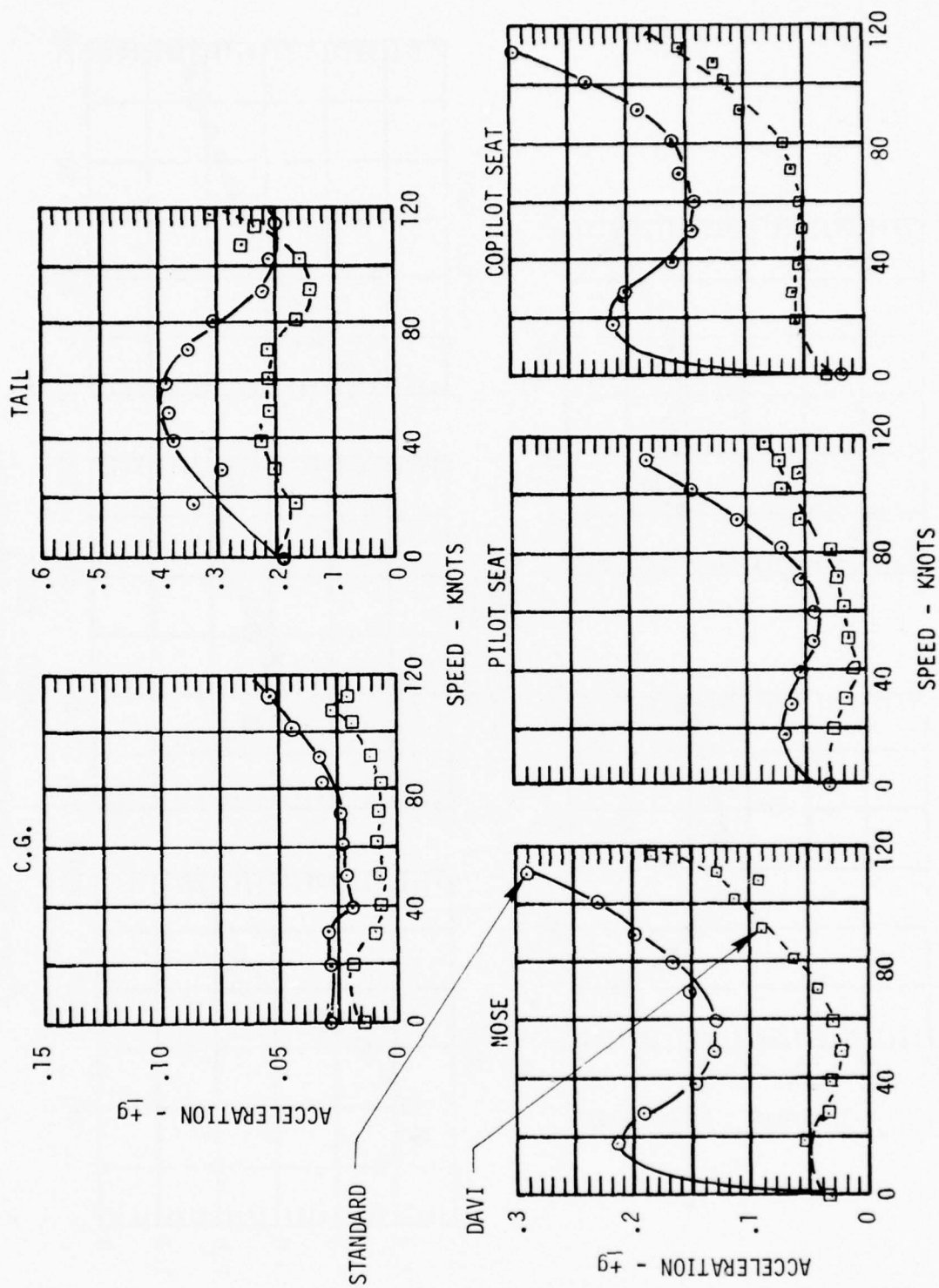

Figure 27. Two-Per-Rev Vertical Response of the 9500-Pound UH-1H Helicopter

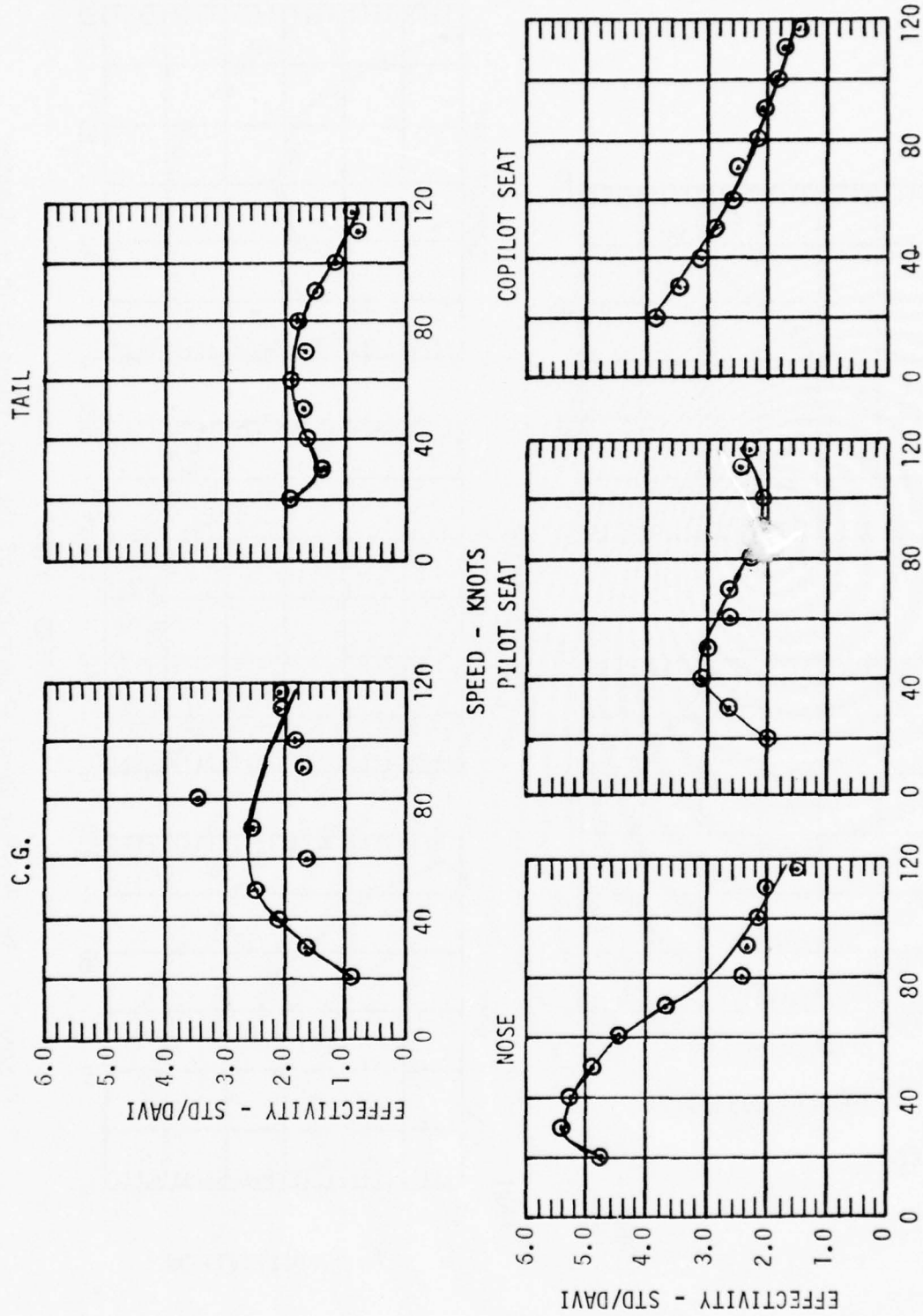

Figure 28. Two-Per-Rev Vertical Effectivity

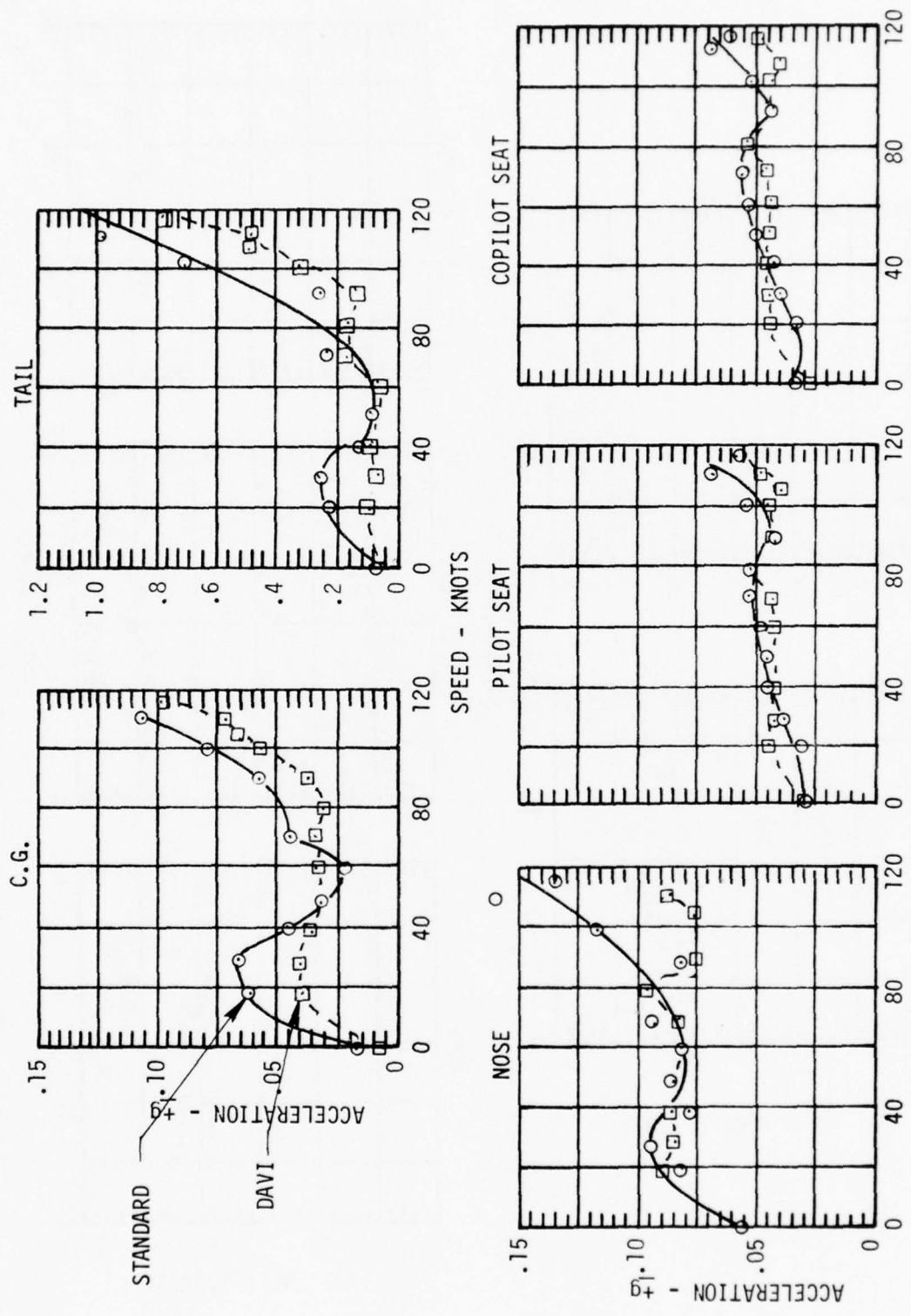

Figure 29. Two-Per-Rev Lateral Response of the 8250-Pound UH-1H Helicopter

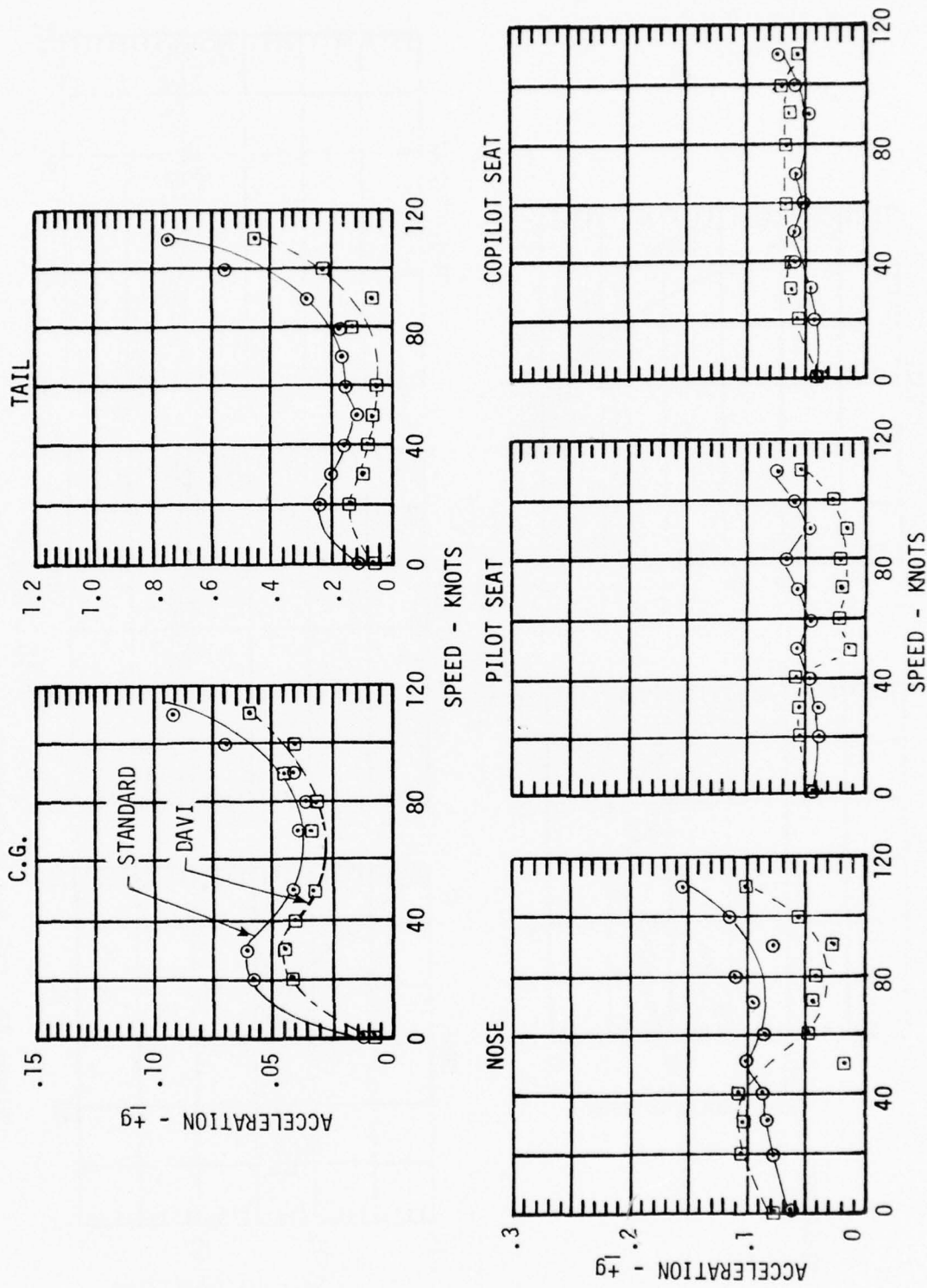

Figure 30. Two-Per-Rev Lateral Response of the 9500-Pound UH-1H Helicopter

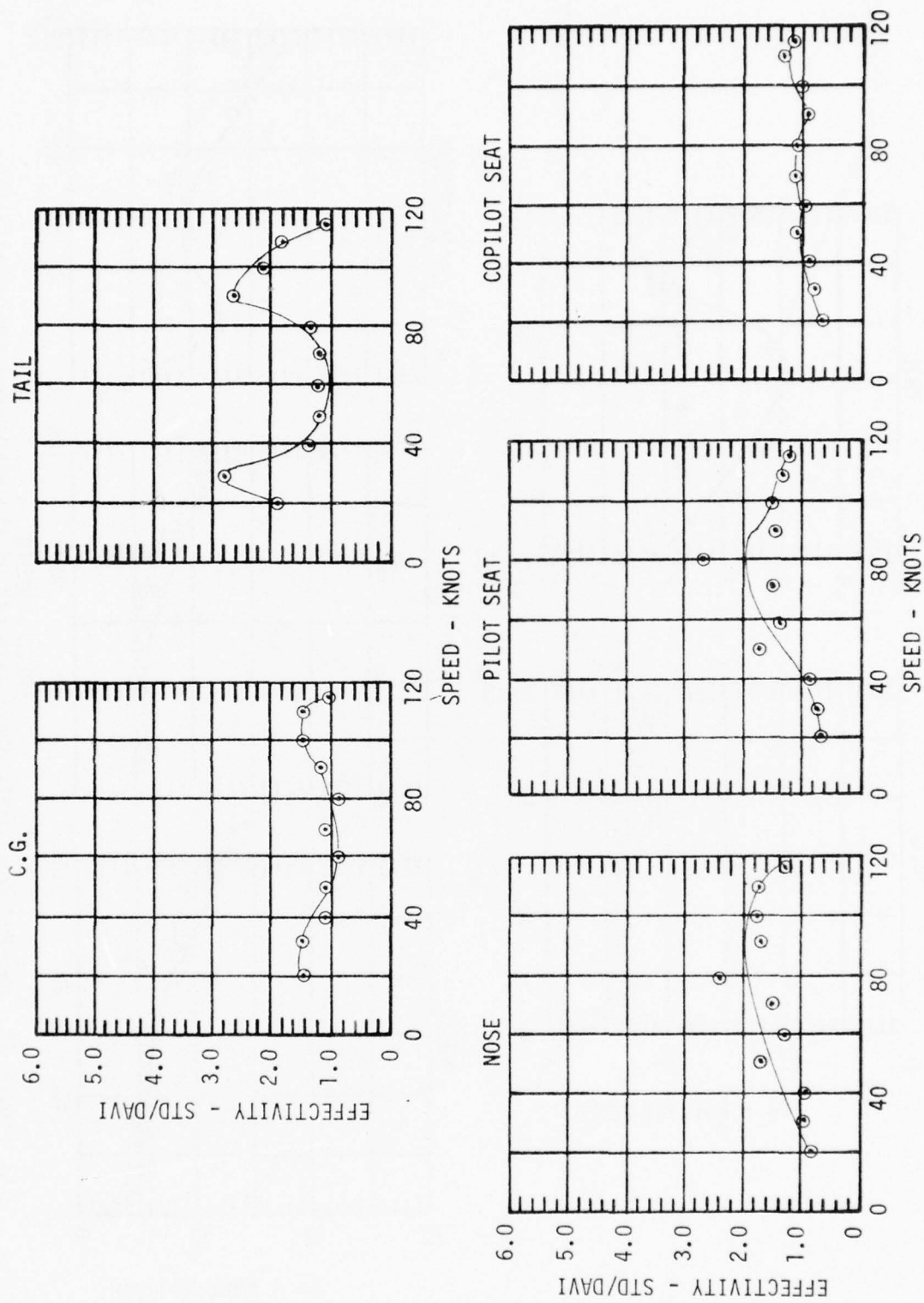

Figure 31. Two-Per-Rev Lateral Effectivity

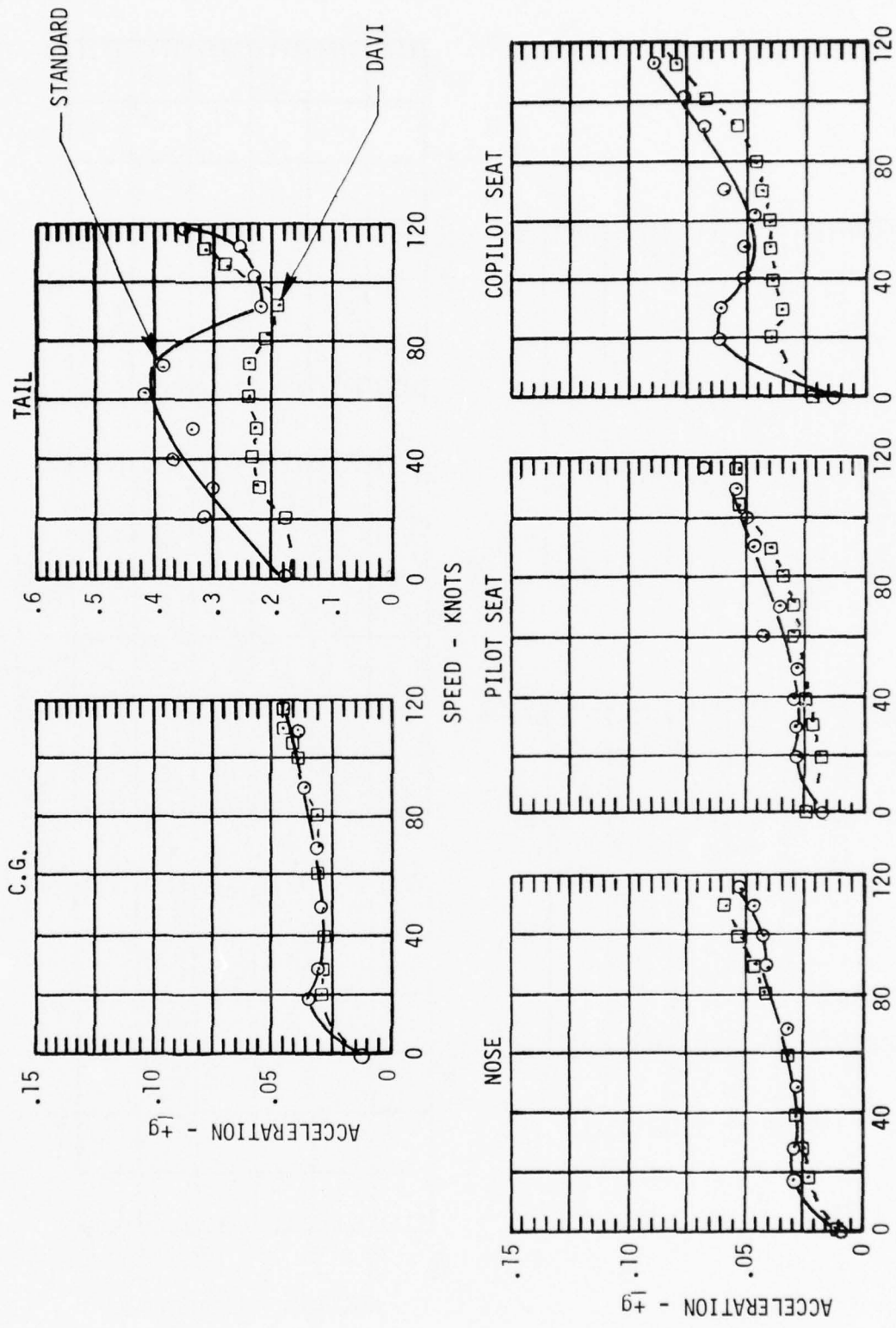

Figure 32. Two-Per-Rev Longitudinal Response of the 8250-Pound UH-1H Helicopter

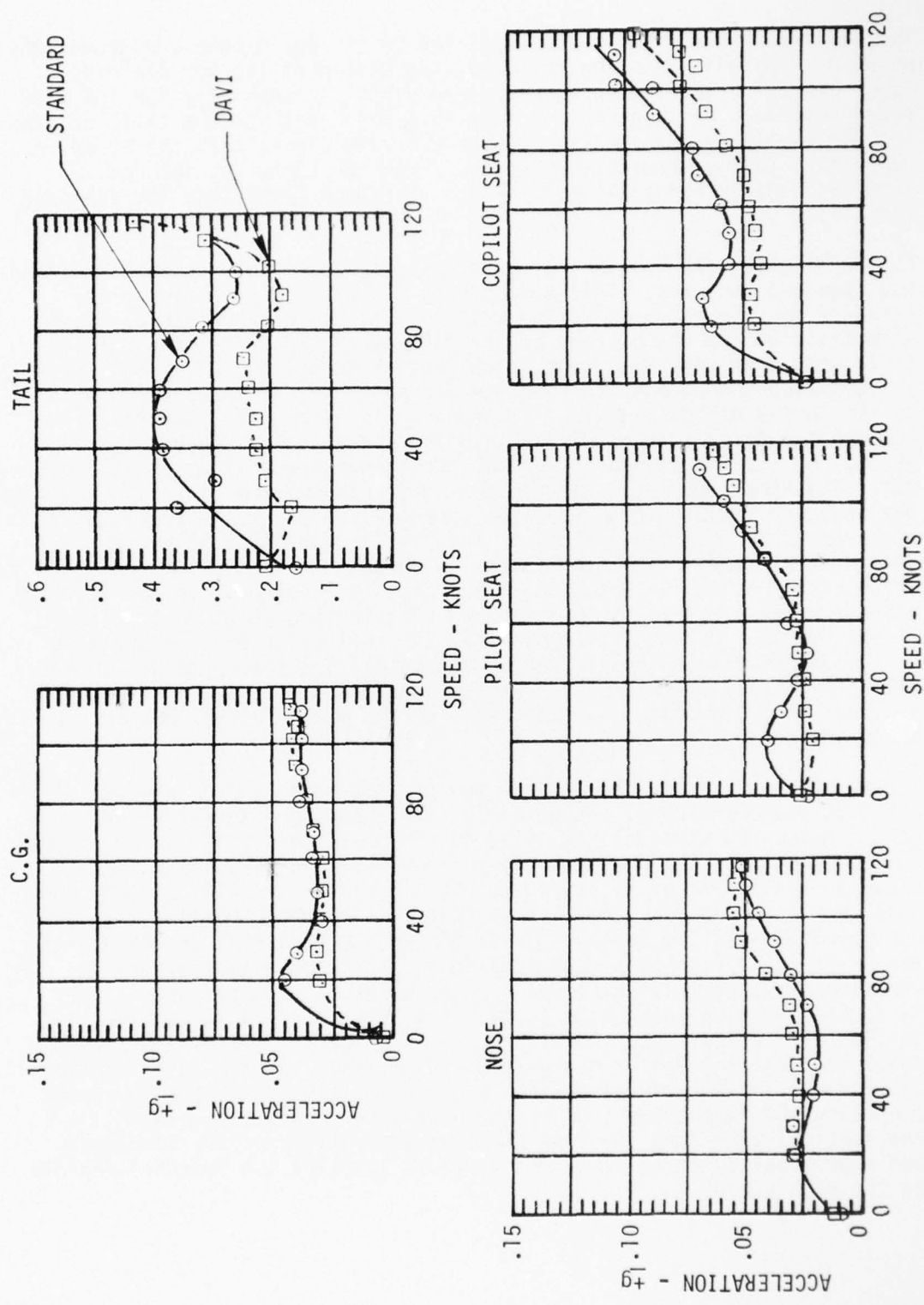

Figure 33. Two-Per-Rev Longitudinal Response of the 9500-Pound UH-1H Helicopter

The vertical two-per-rev response at the cg is low in both configurations. However, even with this low response, the DAVI-modified vehicle had a lower vibration level than the standard vehicle, especially for the 9500-pound vehicle. It is also seen from this data that for the tail location the DAVI-modified vehicle had a lower vibration level than the standard vehicle up to approximately 80 knots. From 100 knots up, the DAVI-modified vehicle had a slightly higher vibration level than the standard vehicle.

Figure 28 gives the two-per-rev vertical effectivity of the DAVI-modified and standard vehicles. This effectivity is obtained by dividing the standard vehicle response by the DAVI-modified vehicle response. These effectivities are the average of the 8250-pound and 9500-pound results. It is seen from this data that a substantial reduction in vibration level was achieved throughout the fuselage and over most of the speed regime by the DAVI-modified vehicle. At the nose location, the vibration level was reduced to less than 1/5 the standard level at low speed and to an average of 1/2 the standard level at the higher speed area. At the pilot seat, the vibration level was reduced to 1/2 to 1/3 the vibration level of the standard vehicle throughout the speed regime. For the copilot seat area, the DAVI-modified helicopter reduced the vibration level to 1/4 that of the standard vehicle at the low-speed area and 1/2 at the high-speed area. At the cg location, the vibration level was reduced to approximately 1/2 that of the standard vehicle throughout most of the flight regime. For the tail location, the vertical vibration obtained on the DAVI-modified vehicle was approximately 1/2 that obtained on the standard vehicle throughout the mid-speed range. A slight increase in tail vertical vibration was obtained with the DAVI-modified vehicle at 110 knots and above.

Figures 29 and 30 show the lateral two-per-rev response for the 8250- and 9500-pound vehicles, respectively. In comparing Figures 26 and 27 (the two-per-rev vertical responses of the UH-1H helicopter) with Figures 29 and 30, it is seen that the two-per-rev lateral vibration for the standard configuration is approximately .1g at the transition speed and reaching approximately .15g at high speed at the nose location. This is approximately 1/2 the vertical level of the standard configuration. At the pilot's and copilot's seat locations, the lateral two-per-rev vibration is .05g to .07g at all speeds, which is approximately 1/2 to 1/3 the vertical vibration level. The lateral cg vibration level is .06g at the low speed and .10g at the high speed. This is approximately twice the level of the vertical direction. At the tail location, the lateral two-per-rev vibration is approximately .2g at the low-speed condition and approaches 1.0g at the high-speed condition. This is 1/2 the vertical vibratory level of the standard vehicle at the low speed and approximately three times the vertical level of the standard vehicle at the high speed.

It is further seen from Figures 29 and 30 that the DAVI-modified vehicle had lower two-per-rev lateral vibration levels than the standard vehicle at most locations and throughout the speed range. The reductions obtained are shown in Figure 31. Figure 31 gives the two-per-rev lateral effectivities of the DAVI-modified and standard vehicles. These effectivities are obtained by dividing the standard vehicle responses by the DAVI-modified vehicle responses. These effectivities are the average of the 8250-pound and 9500-pound results. It is seen from this figure that at every location except the copilot seat some improvement in the lateral vibration level was achieved. At the copilot seat, the vibration level of .05g remained essentially the same.

Figures 32 and 33 show the longitudinal two-per-rev responses for the 8250- and 9500-pound vehicles, respectively. It is seen from these curves that in the nose, pilot, and cg locations, the DAVI-modified vehicle and the standard vehicle had similar responses. At the copilot seat location, a small reduction of the vibration level was achieved with the DAVI-modified vehicle throughout the speed range. The greatest reduction of the vibration level in the longitudinal direction was obtained at the tail location. In the low-speed and mid-speed ranges, the DAVI-modified vehicle reduced the vibration levels to approximately 1/2 the levels of the standard vehicle. At the high-speed conditions, the 8250-pound, DAVI-modified helicopter had a small increase in vibration levels compared to the standard vehicle; whereas, for the 9500-pound vehicle, the vibration level was slightly less for the DAVI-modified helicopter.

Tables 5 and 6 show the two-per-rev vibratory responses of the isolated fuselage of the 8250-pound and 9500-pound test vehicles, respectively, for the steady-state turn maneuvers. It is seen from these tables that for most every location and maneuver, the DAVI-modified vehicle had a lower two-per-rev vertical response than the standard vehicle.

For the hover turns for both gross weights and the 50-knot right turn for the 8250-pound vehicles, the DAVI-modified vehicle had lower responses in the lateral direction than the standard vehicle. However, for the remaining maneuvers, in general, the DAVI-modified vehicle had higher responses than the standard system. The longitudinal two-per-rev responses had similar trends as the lateral responses.

It is seen from a comparison of Tables 5 and 6 with Figures 26, 27, 29, and 30, that for the straight and level flight conditions, the DAVI-modified vehicle had greater buildups in response in maneuvers than the standard vehicle. The average buildups for both gross weights and for the 50-knot and 90-knot turns for the standard vehicle were only 8 percent greater vertically and 27 percent greater laterally than the straight and level results at these speeds. For the same conditions, the average buildups for the DAVI-modified vehicle were 73 percent greater vertically and 116 percent greater laterally than the straight and level results at these speeds. The reason for the greater percentage buildups in the DAVI-modified vehicle is unknown. Possibly the nonlinearities in the spring

TABLE 5. TWO-PER-REV VIBRATORY RESPONSE FOR THE 8250-POUND TEST VEHICLE FOR STEADY-STATE TURNS

Speed (Knots)	Trnsdcr Dir	Transducer Location and Magnitude - tg														
		Nose			Pilot Seat			Copilot Seat			CG			Tail		
		Std	DAVI	E*	Std	DAVI	E*	Std	DAVI	E*	Std	DAVI	E*	Std	DAVI	E*
0	VT	.085	.034	2.5	.060	.027	2.22	.058	.023	2.52	.028	.025	1.12	.155	.155	1.00
	LT	.060	.064	.94	.042	.034	1.23	.044	.023	1.91	.014	.014	1.00	.095	.062	1.53
	LONG	.027	.018	1.5	.034	.022	1.54	.044	.026	1.69	.017	.011	1.54	.143	.153	.93
50	VT	.095	.022	4.3	.013	.016	.81	.125	.049	2.55	.029	.006	4.83	.395	.215	1.84
	LT	.102	.082	1.24	.065	.046	1.41	.070	.048	1.45	.029	.035	.82	.066	.063	1.05
	LONG	.031	.032	.97	.037	.030	1.23	.051	.042	1.21	.039	.030	1.30	.398	.238	1.67
50	VT	.126	.049	2.57	.025	.076	.33	.153	.089	1.72	.049	.035	1.40	.432	.297	1.45
	LT	.120	.144	.83	.067	.085	1.02	.091	.090	1.01	.037	.045	.82	.061	.052	1.17
	LONG	.043	.040	1.00	.058	.042	1.38	.066	.046	1.43	.054	.041	1.32	.474	.347	1.36
90	VT	.169	.067	1.94	.091	.066	1.37	.168	.103	1.63	.032	.019	1.66	.197	.153	1.29
	LT	.101	.141	.72	.066	.078	.84	.067	.083	.81	.052	.067	.78	.232	.232	1.00
	LONG	.045	.062	.73	.052	.048	1.08	.075	.082	.91	.042	.050	.84	.224	.140	1.60
90	VT	.163	.077	2.11	.080	.050	1.6	.173	.112	1.54	.029	.010	2.9	.208	.232	.89
	LT	.081	.206	.39	.050	.095	.52	.052	.101	.51	.056	.052	1.08	.380	.214	1.78
	LONG	.044	.062	.70	.052	.057	.91	.072	.078	.92	.039	.054	.72	.245	.232	.84

* EFFECTIVITY - The standard vehicle response divided by the DAVI-modified vehicle response.

TABLE 6. TWO-PER-REV VIBRATORY RESPONSE FOR THE 9500-POUND TEST VEHICLE FOR STEADY-STATE TURNS

		Transducer Location and Magnitude - $\pm g$															
Speed (Knots)	Dir	Trnsdcr Dir	Nose			Pilot Seat			Copilot Seat			CG			Tail		
			Std	DAVI	E*	Std	DAVI	E*	Std	DAVI	E*	Std	DAVI	E*	Std	DAVI	E*
0	RT	VT	.131	.066	1.98	.062	.047	1.32	.112	.064	1.75	.035	.018	1.94	.347	.188	1.84
		LT	.070	.055	1.27	.045	.034	1.32	.049	.035	1.40	.036	.014	2.57	.100	.063	1.59
		LONG	.032	.024	1.33	.039	.031	1.25	.060	.035	1.71	.034	.010	3.4	.310	.235	1.32
50	RT	VT		.042		.056			.056				.022			.247	
		LT		.129		.076			.080				.043			.069	
		LONG		.038		.030			.053				.043			.250	
50	LFT	VT	.176	.098	1.80	.048	.028	1.71	.186	.154	1.21	.060	.027	2.22	.475	.361	1.32
		LT	.124	.158	.78	.090	.106	.84	.096	.112	.86	.046	.063	.73	.085	.137	.62
		LONG	.041	.061	.67	.060	.063	.88	.074	.081	.91	.058	.062	.93	.506	.429	1.20
90	RT	VT	.216	.137	1.50	.111	.080	1.39	.205	.141	1.45	.051	.024	2.13	.275	.216	1.27
		LT	.130	.156	.83	.017	.087	.88	.082	.092	.89	.065	.064	1.01	.220	.182	1.21
		LONG	.043	.059	.73	.051	.053	.96	.086	.090	.96	.047	.053	.89	.265	.224	1.18
90	LFT	VT		.157		.101			.155				.038			.240	
		LT		.160		.102			.107				.064			.128	
		LONG		.062		.065			.093				.061			.282	

* EFFECTIVITY - The standard vehicle response divided by the DAVI-modified vehicle response.

rates of the DAVI were greater than anticipated and an effective change in tuning occurred. However, it would be expected that, for the maneuver done, greater percentage buildups in standard vehicles would have occurred. Therefore, although the steady-state turns were to be the same, it was concluded that a more critical maneuver was done on the DAVI-modified vehicle than on the standard vehicle.

It is seen from Figures 26 through 33 that reductions in two-per-rev responses of the isolated fuselage were achieved with the DAVI isolation system. The greatest reductions occurred in the vertical response of the isolated fuselage in the low-speed flight regime. Although good reductions of vibration levels were obtained at high speed, the buildup in vibration levels at these speeds was similar in trend to the standard vehicle and was not expected. This vibration buildup with increasing forward flight speed led to the suspicion that some form of speed-sensitive aerodynamic excitation was acting on the fuselage. One possible explanation, later confirmed by tests on both standard and DAVI-modified vehicles, is two-per-rev angle-of-attack changes on the horizontal stabilizer producing significant two-per-rev vertical vibratory excitation on the tail boom above 80 knots.

The angle of attack of the UH-1 horizontal stabilizer versus speed is controlled by the position of the cyclic stick via an attachment to the swashplate. Thus, any relative vibratory motion of the transmission with respect to the fuselage could introduce vibratory pitch changes in the horizontal stabilizer, resulting in a vibratory force from the stabilizer. Figure 34 shows the vibratory pitch change measured on the DAVI-modified vehicle and a standard UH-1H helicopter, Serial No. 68-16401. It is seen from these pitch-change results that there was more scatter in the data for the standard vehicle than for the DAVI vehicle. However, the magnitude was essentially the same for both vehicles. From this vibratory pitch, the vibratory force from the horizontal stabilizer was calculated and is given in Figure 34.

It is seen from this figure that, at 80 knots, the force is approximately +5 pounds and, at 115 knots, the force is approximately +30 pounds. Although these forces are not of high magnitudes, because of the location of the horizontal stabilizer on the flexible tail boom, their effect is magnified, causing a high two-per-rev vibratory response.

Four-Per-Rev Airframe Response

Figures 35 through 40 show the four-per-rev response of the standard and DAVI-modified UH-1H helicopters for straight and level flight. Figures 35 and 36 show the four-per-rev vertical responses of the 8250- and 9500-pound vehicles, respectively. It is seen for the 8250-pound vehicles, that at the nose and pilot seat locations, the DAVI-modified vehicle had a slightly higher response at low speed and essentially the same response at high speed as the standard vehicle. At the copilot location and cg locations, the DAVI-modified vehicle had essentially a two-to-one reduction in vibration level at low speed and the same response at high speed as the standard vehicle. The tail vibration level

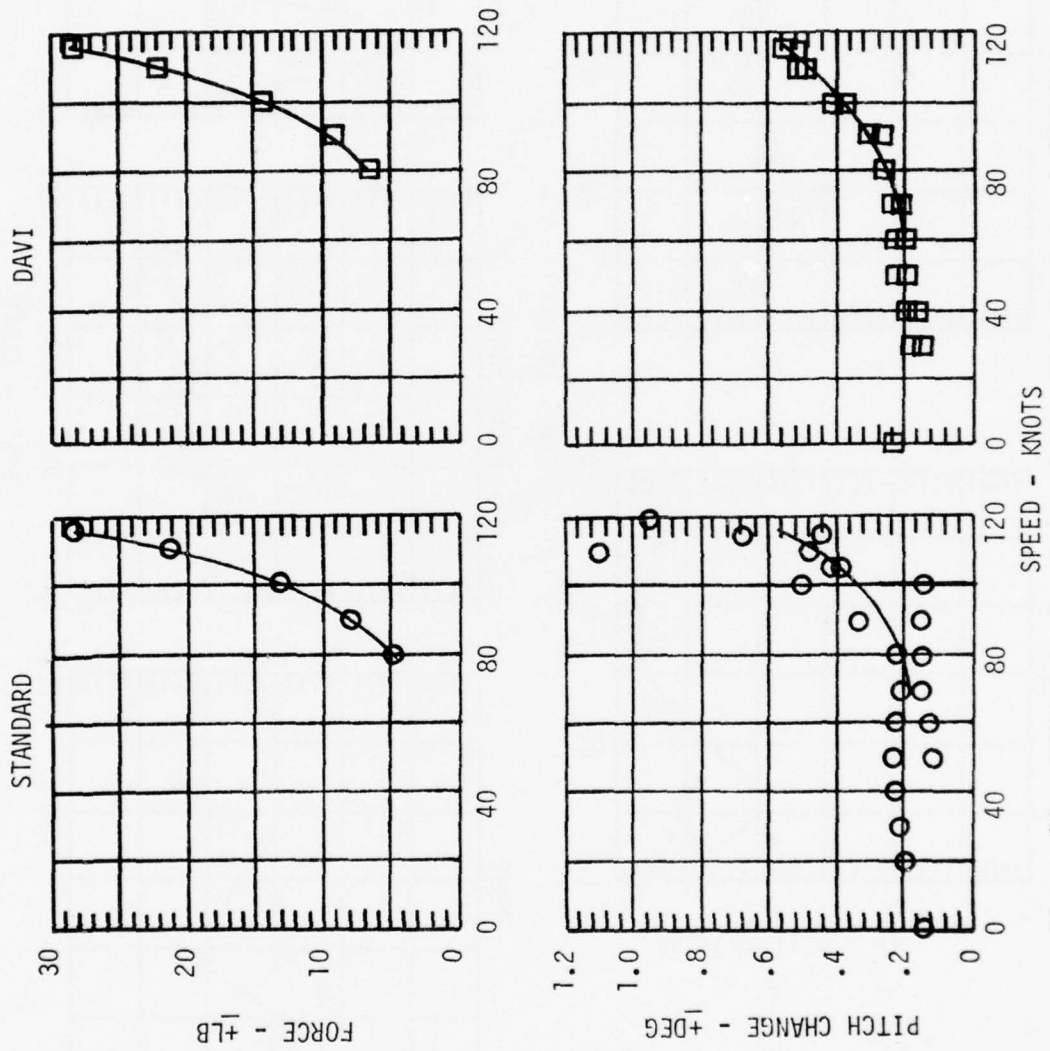

Figure 34. Vibratory Response of the UH-1 Horizontal Stabilizer

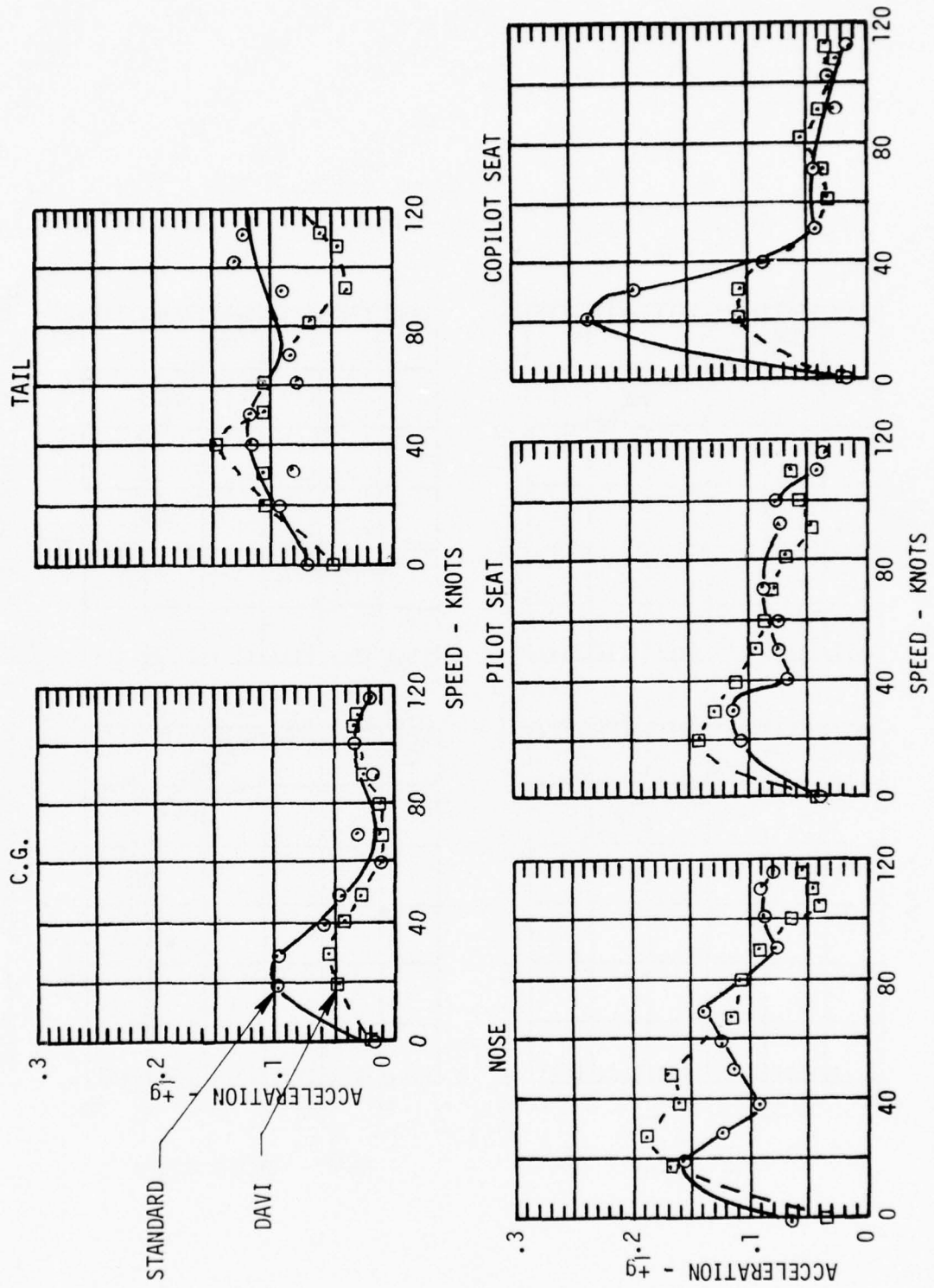

Figure 35. Four-Per-Rev Vertical Response of the 8250-Pound UH-1H Helicopter

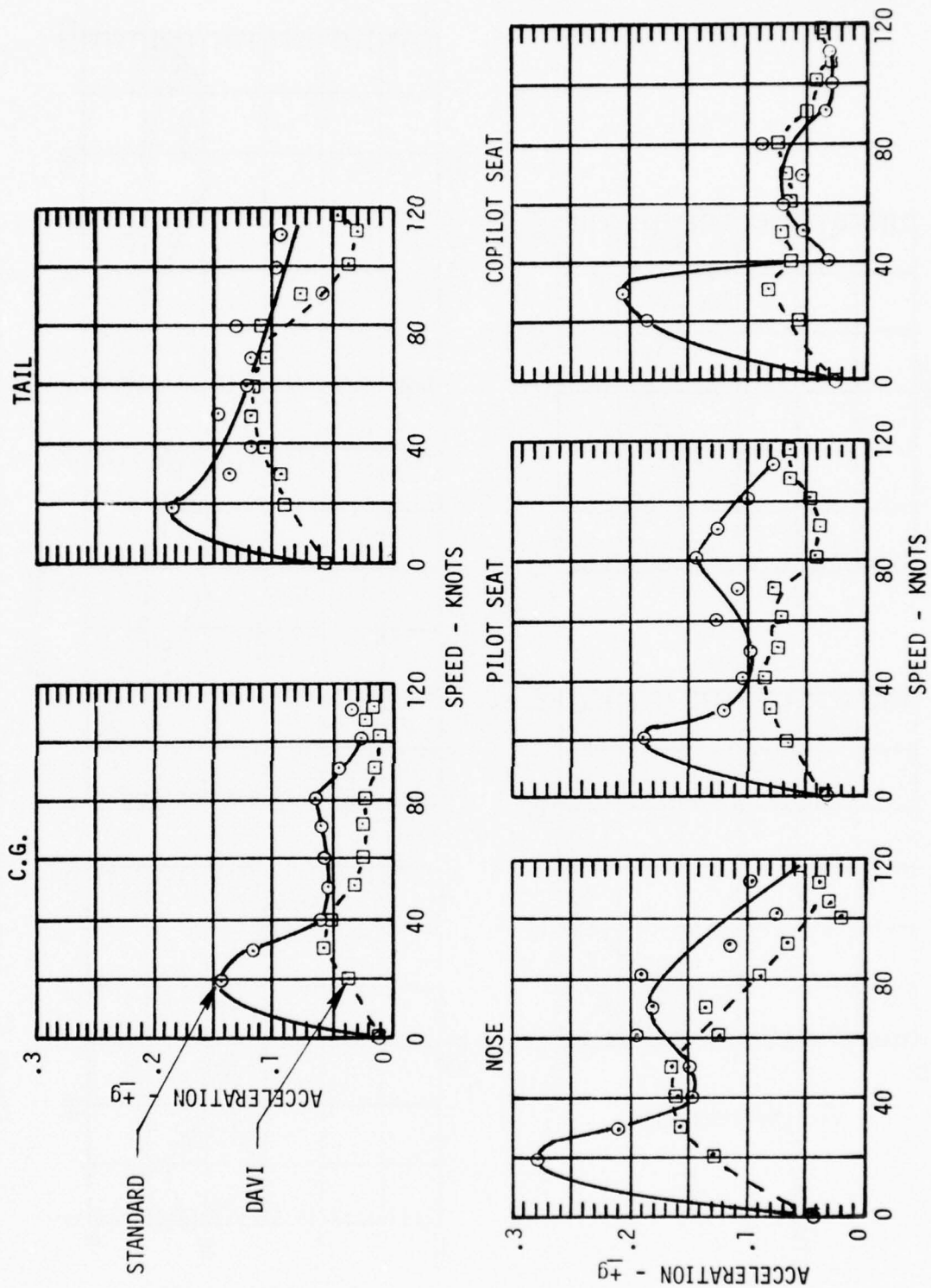

Figure 36. Four-Per-Rev Vertical Response of the 9500-Pound UH-1H Helicopter

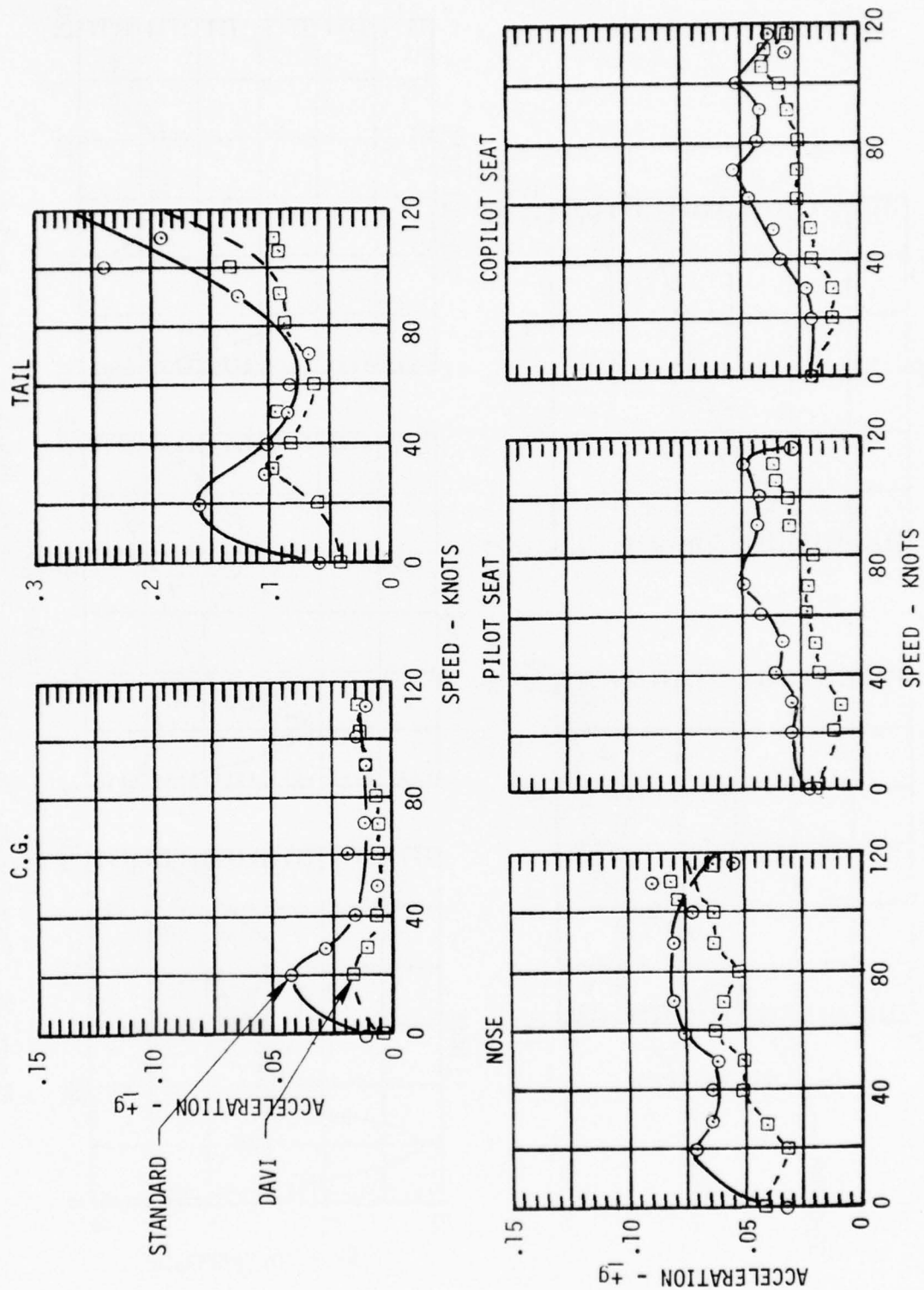

Figure 37. Four-Per-Rev Lateral Response of the 8250-Pound UH-1H Helicopter

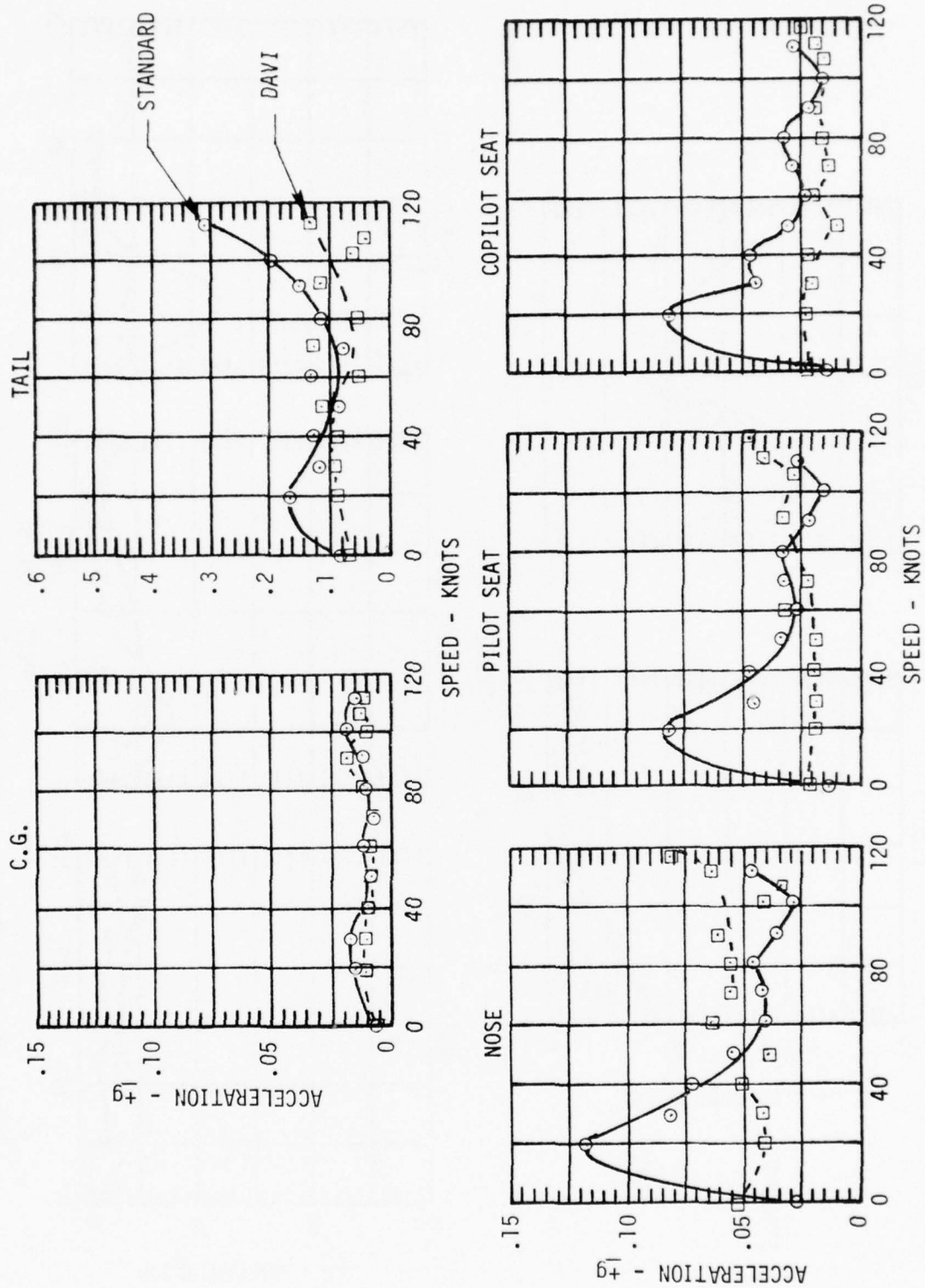

Figure 38. Four-Per-Rev Lateral Response of the 9500-Pound UH-1H Helicopter

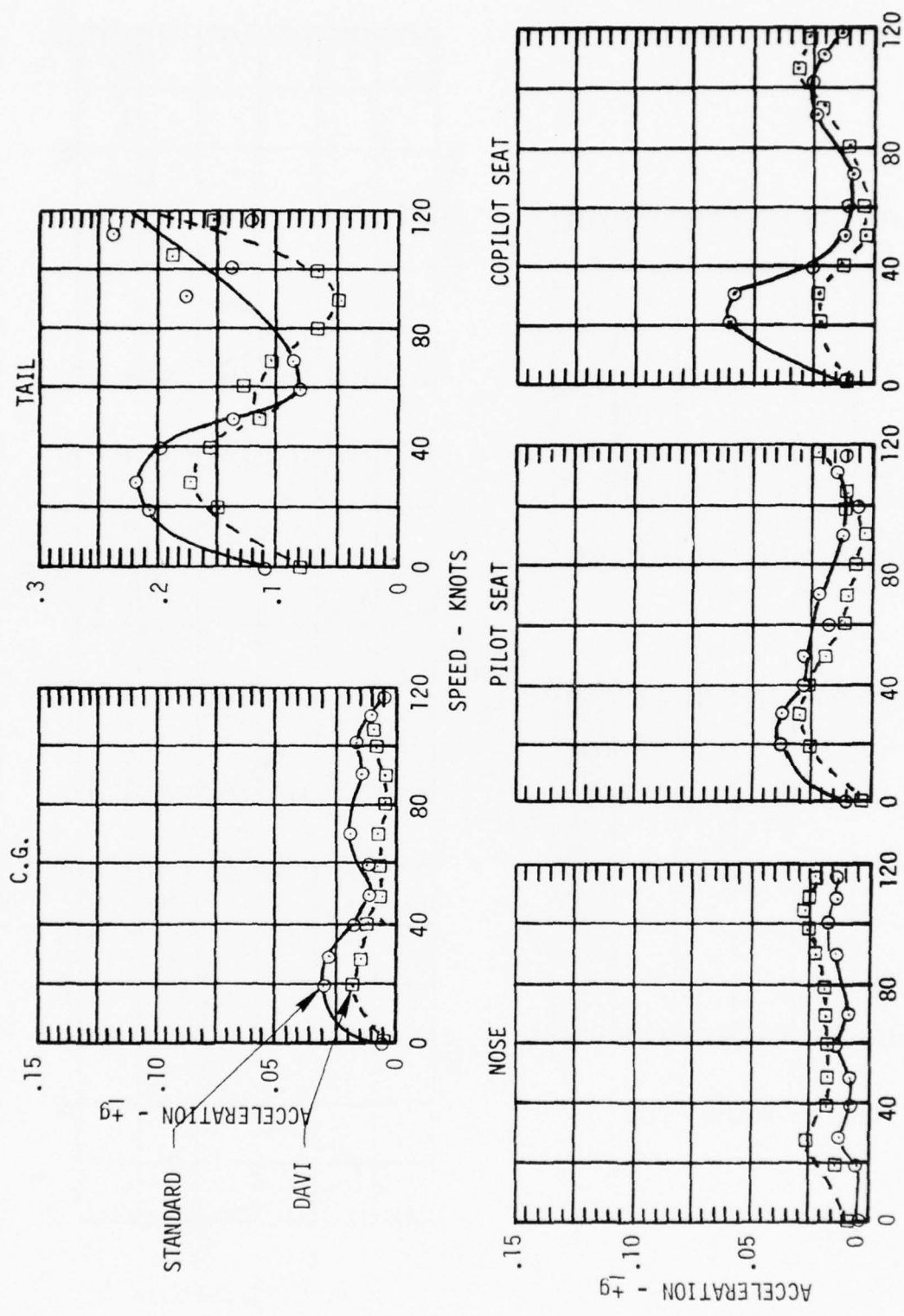

Figure 39. Four-Per-Rev Longitudinal Response of the 8250-Pound UH-1H Helicopter

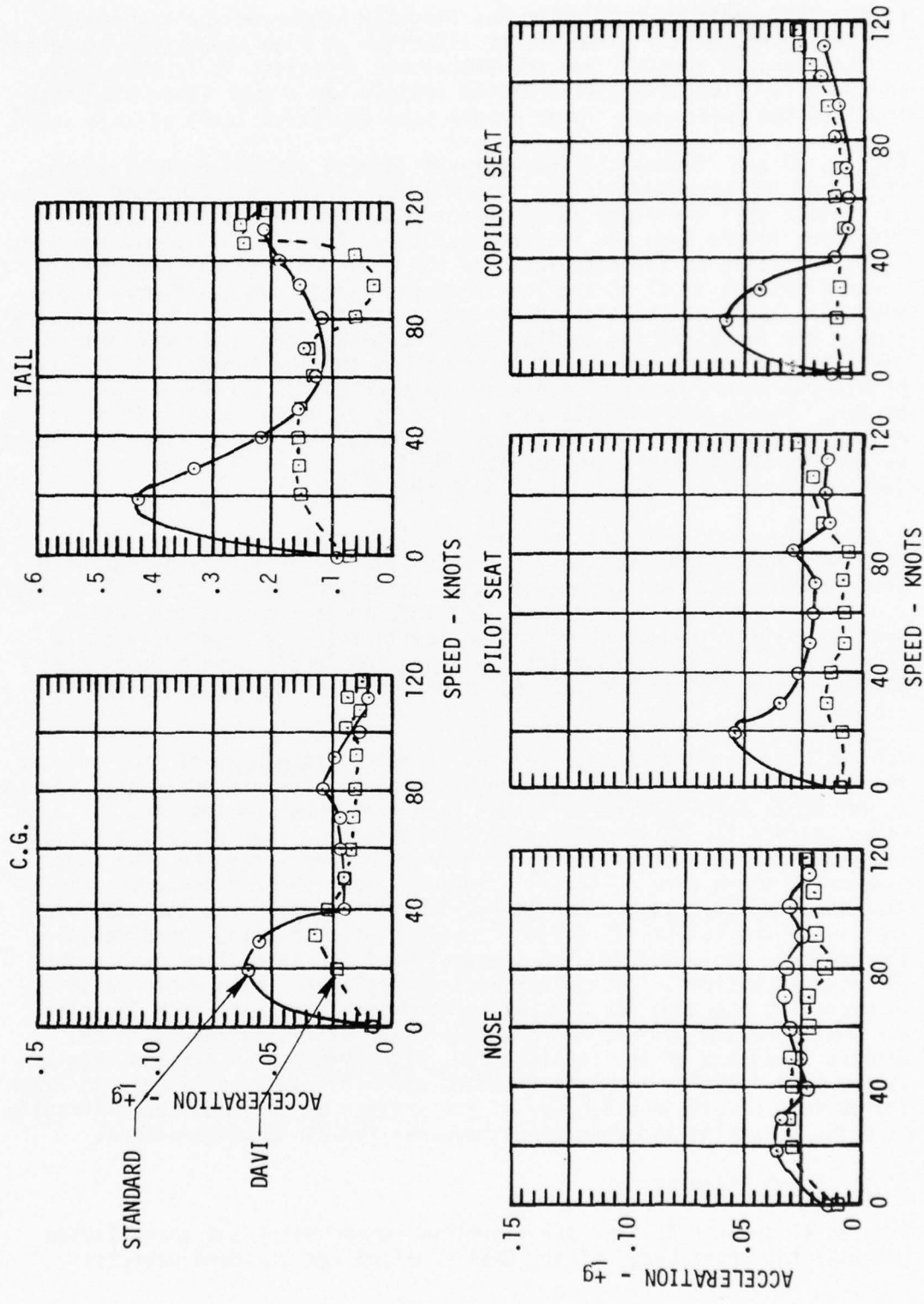

Figure 40. Four-Per-Rev Longitudinal Response of the 9500-Pound UH-1H Helicopter

of the DAVI-modified helicopter was slightly higher at the low speed but had approximately a two-to-one reduction at high speed when compared to the standard system. For the 9500-pound vehicles, it is seen that, at every location, the DAVI-modified vehicle had a much lower vibration level at low speed and a lower or the same vibration level at high speed.

Figures 37 and 38 show the four-per-rev lateral vibration level of the 8250- and 9500-pound vehicles, respectively. For the 8250-pound vehicle, it is seen that for every location the DAVI-modified vehicle had lower vibration levels than the standard vehicle. For the 9500-pound vehicle, it is seen that at the nose location the DAVI-modified vehicle had a lower vibration level at the low-speed conditions and a slightly higher vibration level at the high-speed conditions than the standard configuration. For the pilot and copilot seat locations, the DAVI-modified vehicle had substantially lower vibration levels at the low speeds and approximately the same vibration levels at the high speeds as the standard helicopter. The cg vibration level was extremely low for both configurations. At the tail location, the DAVI-modified vehicle had lower vibration levels at the low speeds and a two-to-one reduction in the vibration levels at the high speeds as compared to the standard vehicle.

Figures 39 and 40 show the four-per-rev longitudinal responses of the 8250- and 9500-pound vehicles, respectively. It is seen that for both gross weights and configurations, the vibration levels, except at the tail location, were usually less than .05g and, in most cases, the DAVI-modified vehicle had lower vibration levels than the standard vehicle. For the tail location, at which the vibration levels were higher, the DAVI-modified vehicle had a lower vibration level than the standard vehicle.

Tables 7 and 8 show the four-per-rev vibratory responses of the isolated fuselages of the 8250- and 9500-pound test vehicles, respectively, for the steady-state turn maneuvers. It is seen from these tables that for both gross weights the DAVI-modified vehicle had much lower vibration levels than the standard vehicle in hover turns. However, for the other turn maneuvers, there were no definite trends. For the 8250-pound vehicle, the DAVI-modified vehicle had lower vibration levels than the standard vehicle in the lateral direction. However, for the 9500-pound vehicle, the standard configuration had lower lateral vibration levels than the DAVI configurations. In the vertical direction for both gross weights, in averaging the data for the two forward speed turns at each location, the DAVI-modified vehicle had slightly lower vibration levels in the forward locations of the fuselage and slightly higher vibration levels at the tail location than the standard vehicle. It is difficult to reach any obvious conclusions because of the scatter of data and the difficulty of doing a precise and consistent maneuver for all configurations.

Transmission Response

Figures 41 through 43 show the vibratory responses of the transmission (nonisolated upper body) of the DAVI-modified and standard vehicles

TABLE 7. FOUR-PER-REV VIBRATORY RESPONSE FOR THE 8250-POUND TEST VEHICLE FOR STEADY-STATE TURNS

Speed (Knots)		Transducer Location and Magnitude - $\pm g$																	
		Trnsdcr Dir		Nose			Pilot Seat			Copilot Seat			CG			Tail			
		Dir	Dir	Std	DAVI	E*	Std	DAVI	E*	Std	DAVI	E*	Std	DAVI	E*	Std	DAVI	E*	
0	RT	VT	.106	.053	2.0	.084	.026	3.23	.066	.026	2.54	.027	.004	6.75	.074	.043	1.72		
		LT	.070	.035	2.0	.033	.015	2.20	.039	.017	2.29	.019	.004	4.75	.129	.070	1.84		
		LONG	.018	.007	2.6	.039	.004	9.75	.017	.007	2.42	.026	.006	4.33	.080	.043	1.86		
50	RT	VT	.184	.134	1.37	.108	.079	1.36	.087	.073	1.19	.055	.030	1.67	.111	.109	1.02		
		LT	.060	.026	2.30	.027	.071	2.45	.022	.014	2.00	.035	.015	2.33	.185	.084	2.20		
		LONG	.020	.015	1.33	.032	.015	2.13	.009	.009	1.00	.019	.013	1.46	.124	.121	1.02		
50	LFT	VT	.107	.135	.79	.079	.084	.94	.096	.094	1.02	.050	.067	.74	.077	.117	.66		
		LT	.046	.030	1.53	.034	.014	2.43	.037	.015	2.46	.025	.022	1.14	.077	.057	1.35		
		LONG	.009	.011	.82	.014	.020	.70	.020	.020	1.00	.021	.013	1.62	.072	.120	.6		
90	RT	VT	.101	.101	1.00	.089	.039	2.28	.013	.057	.23	.021	.031	.67	.067	.087	.77		
		LT	.081	.060	1.35	.043	.034	1.26	.041	.040	1.03	.026	.009	2.89	.184	.146	1.26		
		LONG	.016	.019	.84	.027	.004	6.75	.019	.016	1.19	.019	.006	3.17	.165	.119	1.38		
90	LFT	VT	.118	.114	1.03	.087	.061	1.43	.015	.073	.21	.025	.039	.64	.062	.092	.67		
		LT	.069	.057	1.21	.036	.027	1.33	.036	.030	1.20	.029	.010	2.90	.154	.131	1.17		
		LONG	.009	.017	.53	.020	.007	2.85	.010	.020	.50	.016	.007	2.29	.175	.102	1.72		

* EFFECTIVITY - The standard vehicle response divided by the DAVI-modified vehicle response.

TABLE 8. FOUR-PER-REV VIBRATORY RESPONSE FOR THE 9500-POUND TEST VEHICLE FOR STEADY-STATE TURNS

Speed (Knots)		Transducer Location and Magnitude - μg																	
		Trnsdcr Dir		Nose			Pilot Seat			Copilot Seat			CG			Tail			
				Std	DAVI	E*	Std	DAVI	E*	Std	DAVI	E*	Std	DAVI	E*	Std	DAVI	E*	
0	RT	VT	.123	.056	2.19	.109	.013	8.38	.112	.029	3.86	.053	.012	4.42	.118	.067	1.76		
		LT	.059	.032	1.84	.046	.017	2.70	.049	.023	2.13	.016	.010	1.60	.131	.054	2.43		
		LONG	.024	.013	1.85	.042	.010	4.2	.028	.005	5.6	.032	.010	3.2	.112	.097	1.15		
50	RT	VT	.094			.072			.059			.140							
		LT	.077			.035			.041			.102							
		LONG	.028			.006			.017			.162							
50	LEFT	VT	.108	.076	1.42	.084	.036	2.33	.127	.064	1.98	.071	.035	2.02	.081	.131	.62		
		LT	.065	.076	.86	.037	.040	.93	.040	.042	.95	.022	.018	1.22	.126	.136	.93		
		LONG	.015	.015	1.00	.012	.008	1.5	.021	.015	1.40	.034	.025	1.36	.085	.134	.63		
90	RT	VT	.206	.073	2.82	.176	.045	3.9	.097	.075	1.29	.092	.037	2.49	.060	.087	.69		
		LT	.044	.079	.56	.024	.037	.65	.023	.043	.53	.018	.008	2.25	.176	.115	1.53		
		LONG	.029	.019	1.52	.027	.011	2.45	.010	.021	.47	.036	.021	1.71	.108	.041	2.63		
90	LEFT	VT	.087			.025			.097			.124							
		LT	.096			.050			.054			.132							
		LONG	.017			.024			.021			.098							

* EFFECTIVITY - The standard vehicle response divided by the DAVI-modified vehicle response.

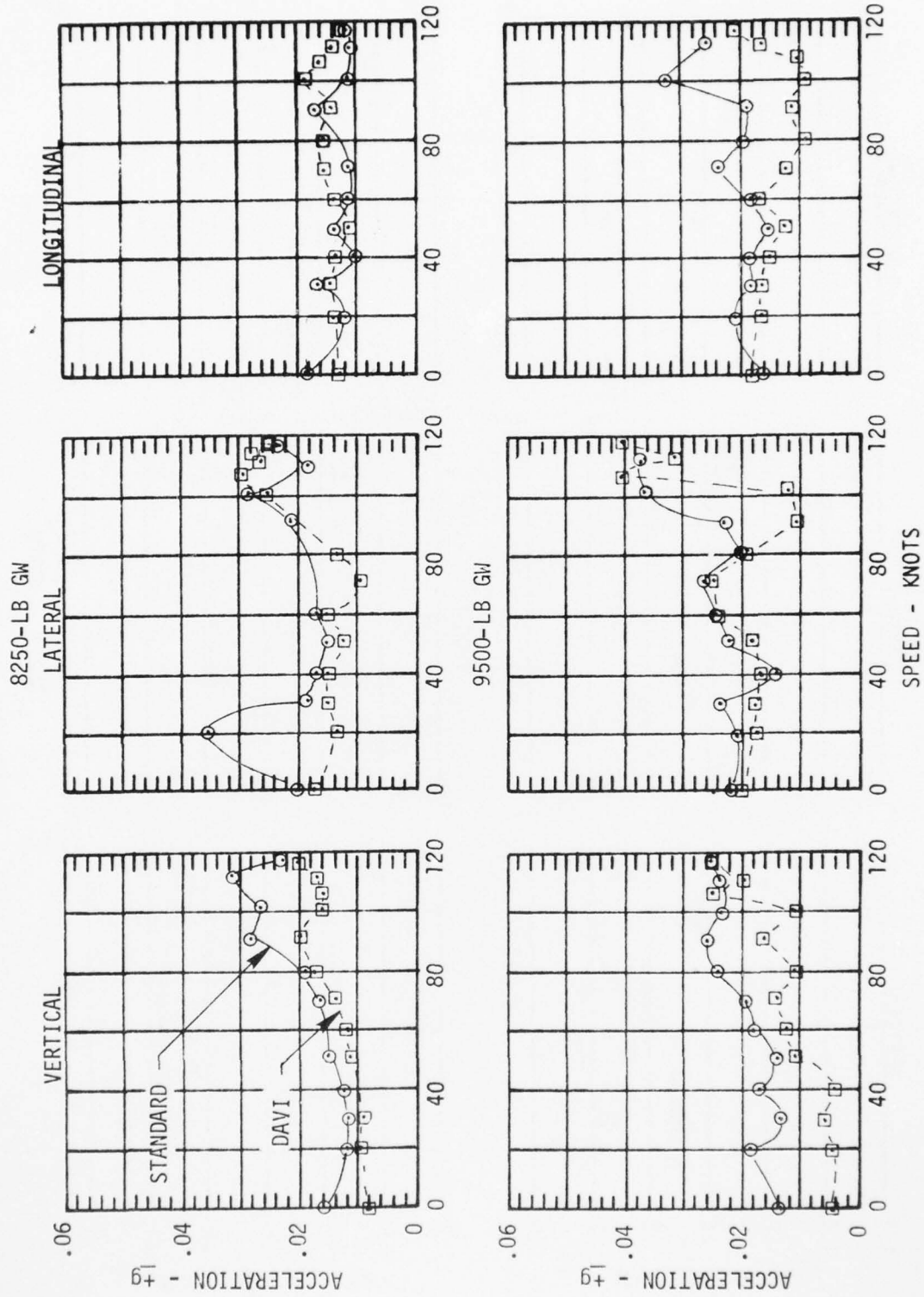

Figure 41. One-Per-Rev Response of the Transmission

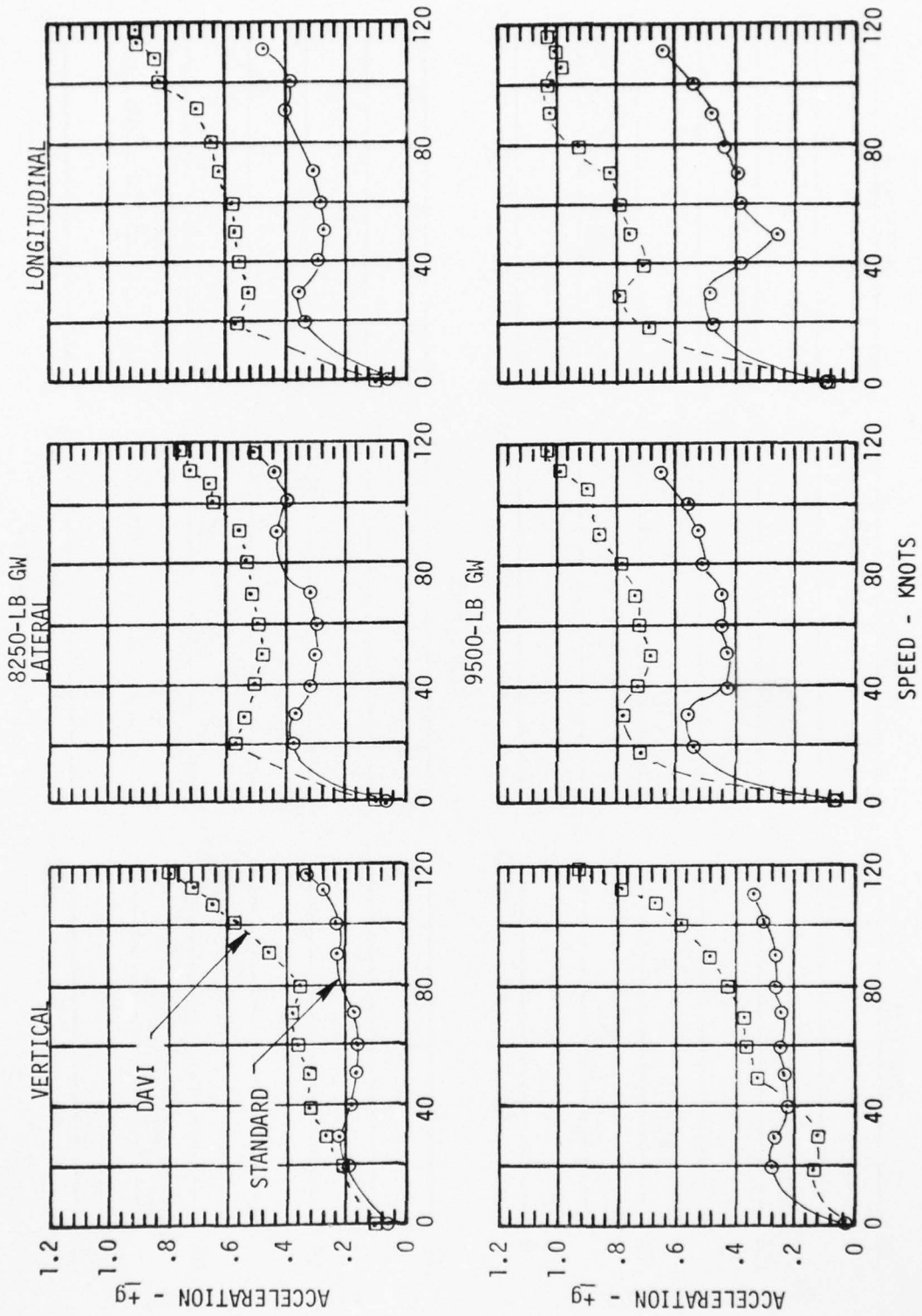

Figure 42. Two-Per-Rev Response of the Transmission

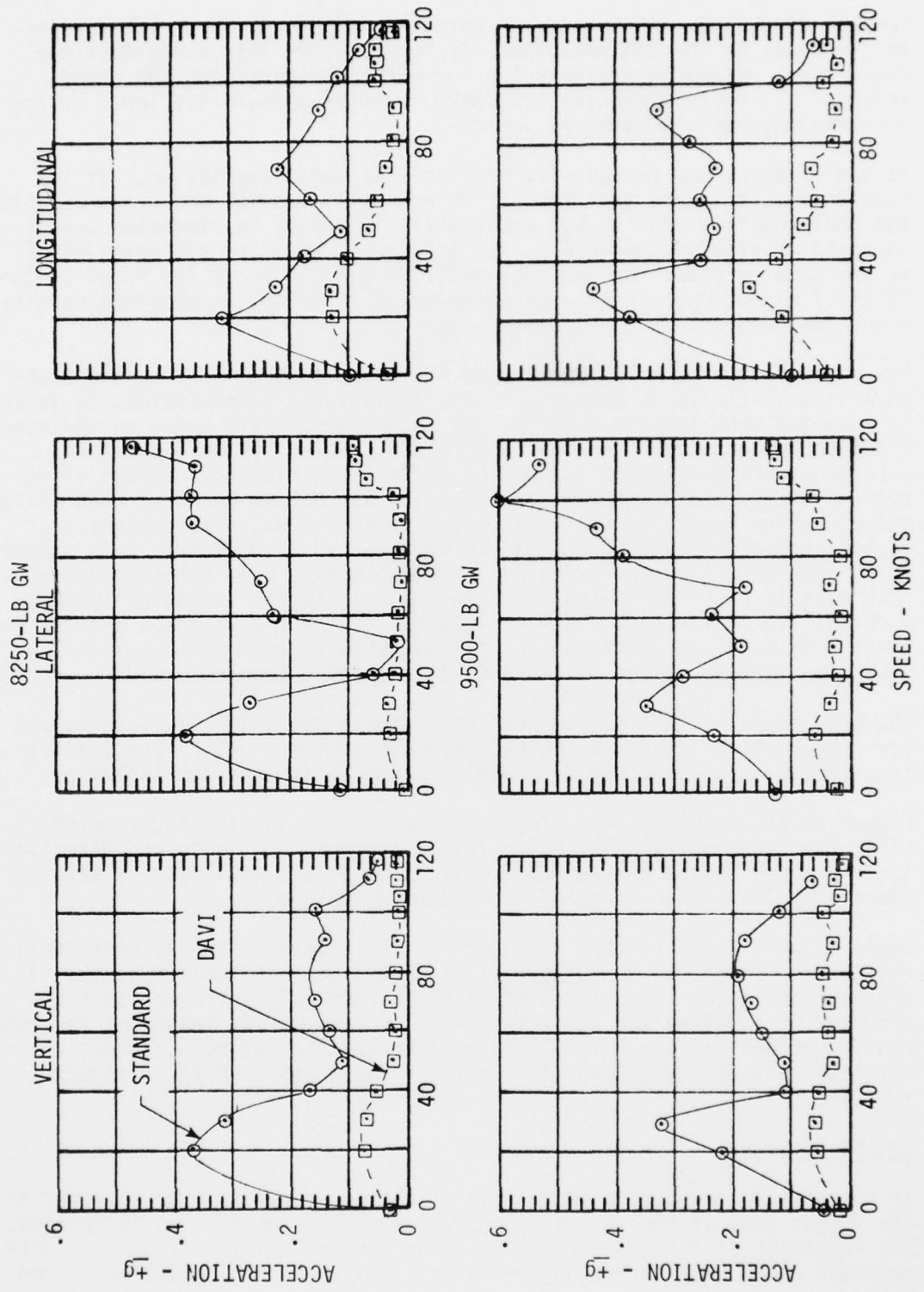

Figure 43. Four-Per-Rev Response of the Transmission

for all directions and both gross weights. Figure 41 shows the one-per-rev response of the transmission. It is seen from this curve that the one-per-rev responses are very low for both configurations and gross weights. In every direction, the DAVI-modified vehicle has lower or the same response as the standard vehicle.

Figure 42 shows the two-per-rev responses of the transmission. It is seen from this figure that for all directions of motion and gross weights the DAVI-modified vehicle had substantial increases in vibration levels as compared to standard vehicles. The only area where the vibration level is the same or lower for the DAVI-modified vehicle is at low speed in the vertical direction. This is also the speed at which the greatest vertical reduction occurred in the isolated fuselage.

For an antiresonant helicopter rotor isolation system in which the fuselage is essentially decoupled from the nonisolated transmission, it is to be expected that increases in the vibration levels will occur on the nonisolated transmission as compared to a nonisolated system. However, because of the relatively low weight of the transmission, a small vibration absorber attached to the transmission may be one means of controlling the vibration levels of the nonisolated transmission, if necessary. Further research and development may be required in this area. As stated in the USAAMRDL Program Review on rotor isolation, Bell Helicopter has had considerable experience with their antiresonant rotor isolation system - a derivative of the DAVI concept. Similar to the DAVI system, the transmission of Bell's isolated vehicles also exhibits higher two-per-rev vibration levels; but no deleterious effects have been observed.

The magnitudes of the longitudinal and lateral vibration level increases over those of the standard vehicle were not anticipated. These changes in vibration responses may indicate a change in inplane hub impedance.

Figure 43 shows the four-per-rev responses of the nonisolated transmission. It is seen from this curve that, for every condition and direction, the vibration levels of the DAVI-modified vehicle's transmission were substantially lower than those of the standard vehicle.

Table 9 shows the vibratory responses of the transmission for both configurations for steady state turns. It is seen from this table that the vibration levels for these types of maneuvers were similar to those that occurred in straight and level flight. The one-per-rev responses for both configurations are low. The DAVI-modified vehicle had much higher two-per-rev responses and much lower four-per-rev responses than the standard vehicle.

Engine Response

It was anticipated that a comparison of engine vibration data obtained in the flight test of the standard and DAVI-modified vehicles would be done. The responses of the accelerometers shown schematically in Figure 15 were recorded on an Army-furnished, on-board, Genisco Model 10-276, wide-band

TABLE 9. VIBRATION RESPONSES OF THE TRANSMISSION FOR STEADY-STATE TURNS

Speed	GW	One-Per-Rev						Two-Per-Rev						Four-Per-Rev					
		Vert.		Lat		Long.		Vert.		Lat		Long.		Vert.		Lat		Long.	
		Std	DAVI	Std	DAVI	Std	DAVI	Std	DAVI	Std	DAVI	Std	DAVI	Std	DAVI	Std	DAVI	Std	DAVI
0 Turn	8250	.018	.005	.026	.012	.033	.012	.096	.114	.143	.144	.181	.140	.133	.013	.327	.027	.218	.024
	9500	.032	.022	.044	.039	.052	.015	.183	.152	.328	.155	.348	.166	.216	.023	.537	.040	.427	.043
50 Right	8250	.024	.009	.019	.021	.022	.015	.196	.320	.419	.549	.330	.620	.161	.037	.189	.037	.152	.093
	9500	.013	.013	.023	.023	.015	.015	.490	.490	.808	.808	.898	.898	.075	.075	.057	.057	.098	.098
50 Left	8250	.019	.016	.022	.019	.018	.021	.186	.611	.408	.649	.350	.762	.156	.092	.040	.155	.228	.152
	9500	.017	.010	.017	.016	.016	.025	.266	.557	.581	1.355	.508	1.336	.169	1.03	.241	.056	.436	.189
90 Right	8250	.030	.008	.032	.019	.022	.022	.219	.518	.452	.817	.373	1.053	.138	.049	.387	.103	.153	.079
	9500	.020	.011	.031	.019	.031	.016	.303	.494	.639	1.039	.585	1.296	.217	.085	.592	.039	.357	.023
90 Left	8250	.028	.019	.023	.010	.017	.016	.233	.591	.427	.818	.393	.999	.167	.055	.408	.084	.214	.099
	9500	.017	.017	.012	.012	.009	.009	.494	.494	1.065	1.065	1.222	1.222	.100	.100	.055	.055	.072	.072

magnetic tape recorder. The data on the magnetic tapes was reduced at Eustis Directorate.

However, with this arrangement of reducing the data after the completion of the flight test, any error in data acquisition or instrumentation could not be corrected. Unfortunately, the 8250-pound data on the standard vehicle and the 9500-pound data on the DAVI-modified vehicle could not be used. Therefore, a valid comparison of engine vibration data could not be made.

Relative Deflection/Coupling Misalignment

One of the major concerns with respect to the vertical isolation of the fuselage from the rotor-induced forces is the relative deflections that occur between the fuselage and transmission due to steady-state loads. These relative deflections can induce engine drive coupling misalignment problems and undesirable control input problems. In order to determine the relative deflections in both the DAVI-modified vehicle and the standard vehicle, linear potentiometers were installed. Figure 13 shows a schematic of the linear potentiometers installed.

It is seen from this figure that four vertical, three longitudinal and two lateral potentiometers were used to record relative motion. Normally only six deflections are required to determine the rigid body angular and linear motions. However, the data obtained from the nine potentiometers were treated statistically to determine the three angular and three linear motions of the transmission with respect to the fuselage. From these data, system (pylon) relative motion and individual DAVI deflections were determined. The pylon relative motions were obtained for the center line of the main rotor shaft at the centroid of the potentiometers, which is 11.5 inches above the isolation system mounting plane (Point "A" on Figure 44).

The DAVI deflections are shown in Table 10. This tabulation, which is based on flight test results, consists of the vertical deflection of each DAVI; the average lateral deflection of the transmission-mount DAVIs; and the average longitudinal deflection of the transmission-mount DAVIs. It is seen from this table that none of the deflections obtained indicated any bottoming of the DAVIs.

Figures 45 and 46 show the results of the analysis of test data for the 8250-pound and 9500-pound vehicles, respectively. In Figure 45, it is seen for the relative torsional deflection of the system that the DAVI-modified vehicle had more torsional deflection, but the same trends-versus-speed as the standard system. The DAVI system was designed to have the same torsional restraints as the standard system; however, in static tests it was determined that the DAVI system was less stiff. Therefore, this increase in torsional deflection was expected. However, this decrease in torsional stiffness had no adverse effects on engine control requirements.

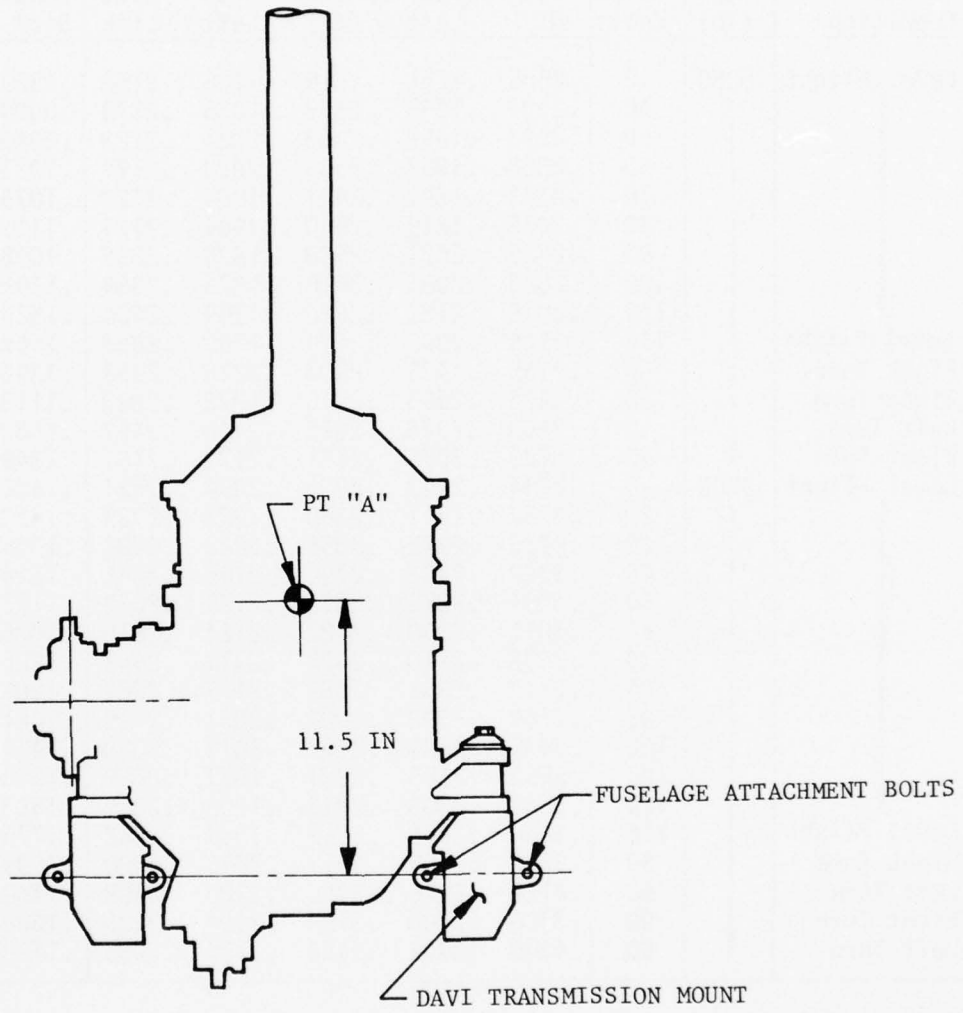

Figure 44. Transmission Mount Schematic

TABLE 10. MEASURED DEFLECTION OF DAVI MOUNTS

Condition	GW (lb)	SP Knots	Deflection - Inch						Long. Dir*	Lat Dir*
			Vertical Direction							
			Fwd Rt	Fwd Left	Aft Rt	Aft Left	Lift Link			
Level Flight ↓	8250 ↓	0	.2505	.1851	.1819	.1786	.2158	.1339	.1146	
		40	.2387	.1865	.2557	.2035	.2178	.0999	.0855	
		50	.2293	.1858	.2463	.2027	.2128	.0943	.1614	
		60	.2383	.1857	.2563	.2038	.2177	.1023	.1752	
		70	.2373	.1807	.2471	.1904	.2120	.1079	.0923	
		80	.2475	.1819	.2560	.1904	.2174	.1133	.0970	
		90	.2725	.2071	.2528	.1875	.2336	.1098	.0939	
		100	.2823	.2083	.2618	.1878	.2389	.1302	.1114	
		110	.3016	.2187	.2628	.1799	.2480	.1523	.1304	
		116	.3135	.2306	.2619	.1789	.2559	.1564	.1339	
		Level Flight	9500 ↓	0	.2165	.1475	.2908	.2218	.2053	.1393
Right Turn	50	.3433		.2995	.2410	.1972	.2893	.1113	.0952	
Right Turn	50	.2803		.2278	.2665	.2140	.2497	.1582	.1055	
Left Turn	90	.3723		.3025	.2871	.2173	.3107	.1349	.1154	
Level Flight	0	.2944		.2103	.2936	.2094	.2521	.1522	.1303	
↓	20	.3287		.2751	.2360	.1824	.2729	.1423	.1218	
	30	.2926		.2292	.2856	.2222	.2587	.1345	.1151	
	40	.3050		.2402	.2794	.2145	.2646	.1216	.1041	
	50	.3004		.2325	.2878	.2199	.2625	.1151	.0985	
	60	.3011		.2353	.2782	.2124	.2610	.1086	.0930	
	70	.2898		.2510	.2699	.2311	.2642	.1226	.1049	
	80	.3147	.2382	.2882	.2117	.2682	.1286	.1100		
	90	.3249	.2398	.2902	.2051	.2715	.1421	.1216		
	100	.3475	.2580	.2907	.2013	.2850	.1497	.1281		
	105	.3650	.2605	.2921	.1877	.2899	.1568	.1342		
	110	.3508	.2503	.2913	.1908	.2819	.1683	.1440		
Level Flight	116	.3640	.2506	.2967	.1834	.2862	.1775	.1519		
Right Turn	50	.3532	.2789	.3017	.2275	.3000	.1599	.1368		
Left Turn	50	.4129	.3345	.3068	.2283	.3405	.1480	.1267		
Right Turn	90	.3986	.2986	.3194	.2194	.3238	.1608	.1376		
Left Turn	90	.4309	.3309	.3124	.2124	.3438	.1428	.1222		

* Average absolute value of the deflection in the mounts in the longitudinal and lateral directions.

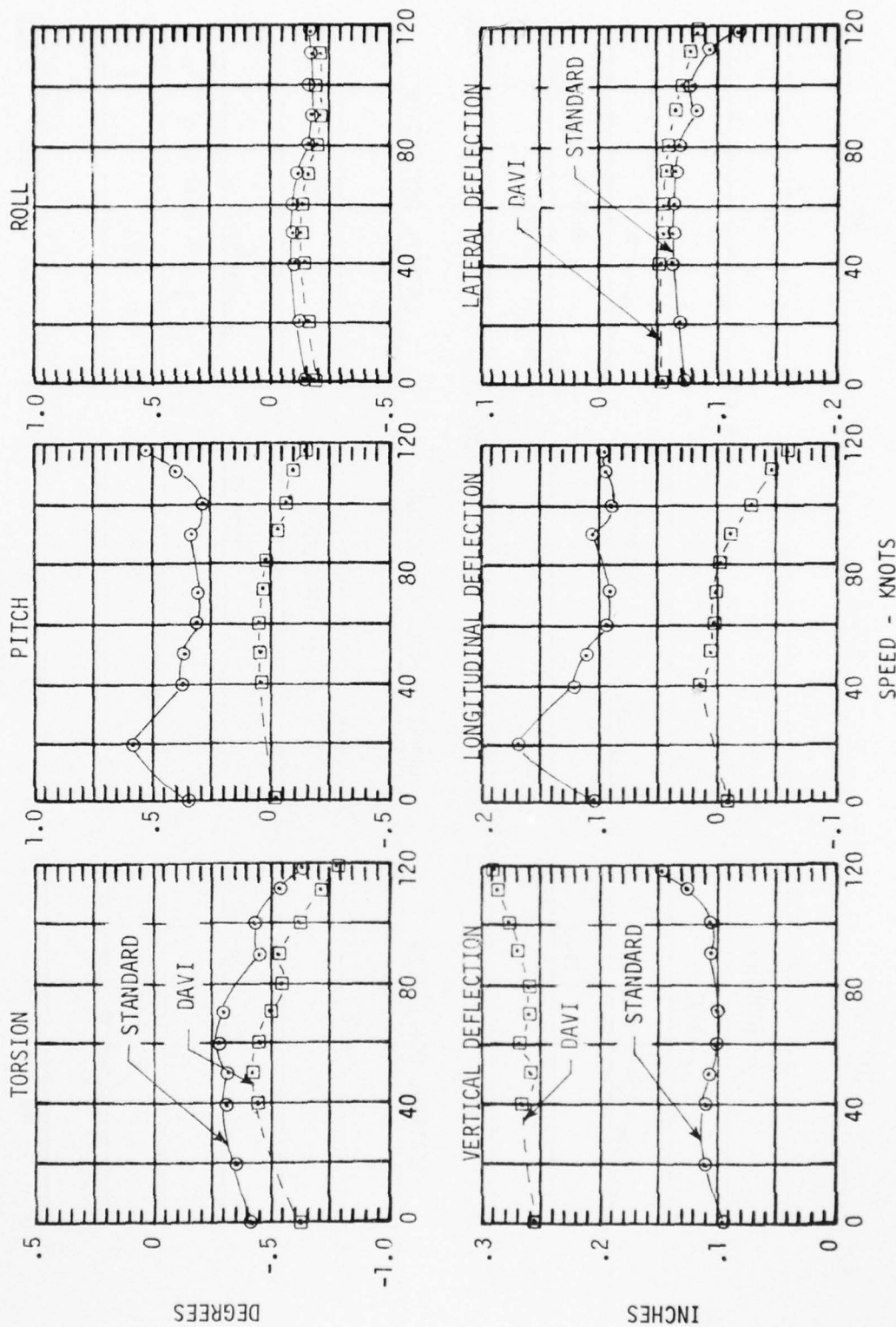

Figure 45. Relative Deflection Between Transmission and Fuselage for the 8250-Pound Helicopter

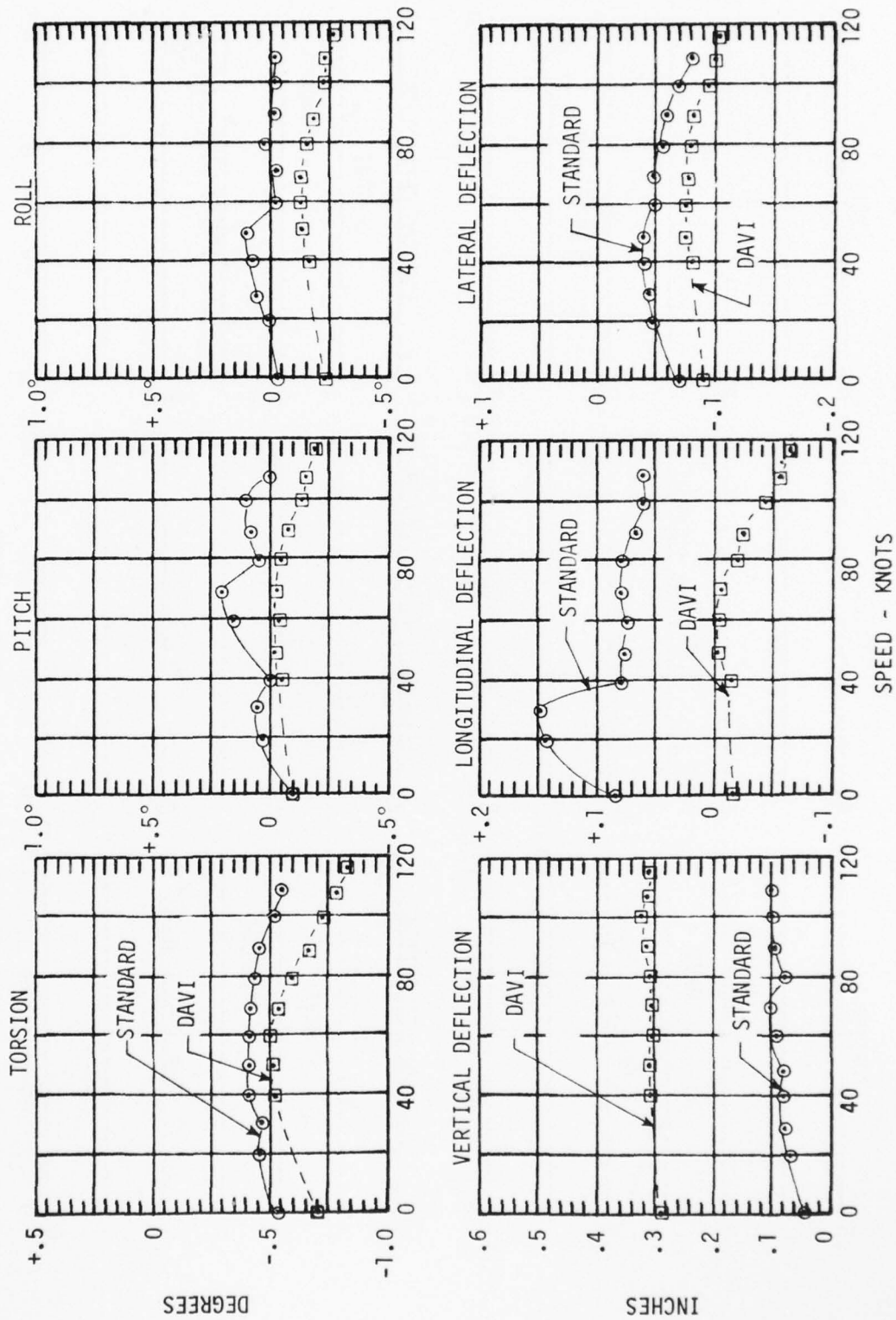

Figure 46. Relative Deflection Between the Transmission and Fuselage for the 9500-Pound Helicopter

It is also seen that there are differences in the deflections in the pitch and longitudinal directions between the DAVI and standard systems. The reason for this difference is the change in the effective center of rotation between the two systems. The standard isolation system has a stiff longitudinal spring rate and a rigid lift link; thus, the center of rotation for the steady loads is restrained to rotate in approximately the plane of the mounting system. The DAVI system has a soft longitudinal spring rate and a flexible lift link, and the center of rotation for steady loads is above the plane of the mounting system. Therefore, at the centroid of the potentiometer system, at which the deflections are referenced, the DAVI system would show smaller longitudinal deflections. In the roll and lateral directions, the angular and translational deflections are essentially the same for both configurations. This is to be expected since the DAVI system was designed to be similar to standard aircraft in this direction.

In the vertical direction, it is seen that the DAVI system had essentially three times the deflection of the standard system. Again, this is to be expected when a system that has vertical isolation is compared to a system without vertical isolation. However, the important criterion is what occurs in flight. It is seen that the DAVI system has essentially the same response-versus-speed as the standard system except for the initial displacement. This initial displacement is accounted for by the compensating control rods that are used to insure proper control input and by the misaligning of the engine drive coupling on the ground that was done to insure proper alignment for flight.

Figure 46 shows the relative deflection obtained between the transmission and the fuselage for the 9500-pound vehicle. It is seen from these results that essentially the same deflections and trends were obtained as for the 8250-pound vehicles.

In order to monitor coupling misalignment in flight, a vertical potentiometer and a lateral potentiometer were installed on the DAVI-modified vehicle at the transmission to engine drive coupling location and calibrated to give coupling misalignment. Figure 47 is a schematic of the engine-transmission installation identifying the instrumented coupling. This schematic also shows that for the unloaded system (zero thrust), the engine drive shaft is misaligned 1.9 degrees with respect to the standard system. This was accomplished by mounting the transmission .30 inch lower. As rotor thrust is applied, the pylon deflects upward and the angular misalignment approaches zero for 1.0g flight. Similarly, both the standard and the DAVI-modified UH-1H isolation systems are statically misaligned -.47 degree in the lateral direction. Figure 48 shows the results obtained for the measured misalignment of the coupling at the transmission. It is seen from these results that the vertical-misalignment-versus-speed was small, the maximum misalignment of 0.4 degree occurring at 116 knots for 8250-pound vehicle. The lateral misalignment was larger than the vertical misalignment. The maximum lateral misalignment, 0.95 degree, occurred at 116 knots for the 9500-pound helicopter. The maximum resultant misalignment was 0.81 degree and 0.97 degree for

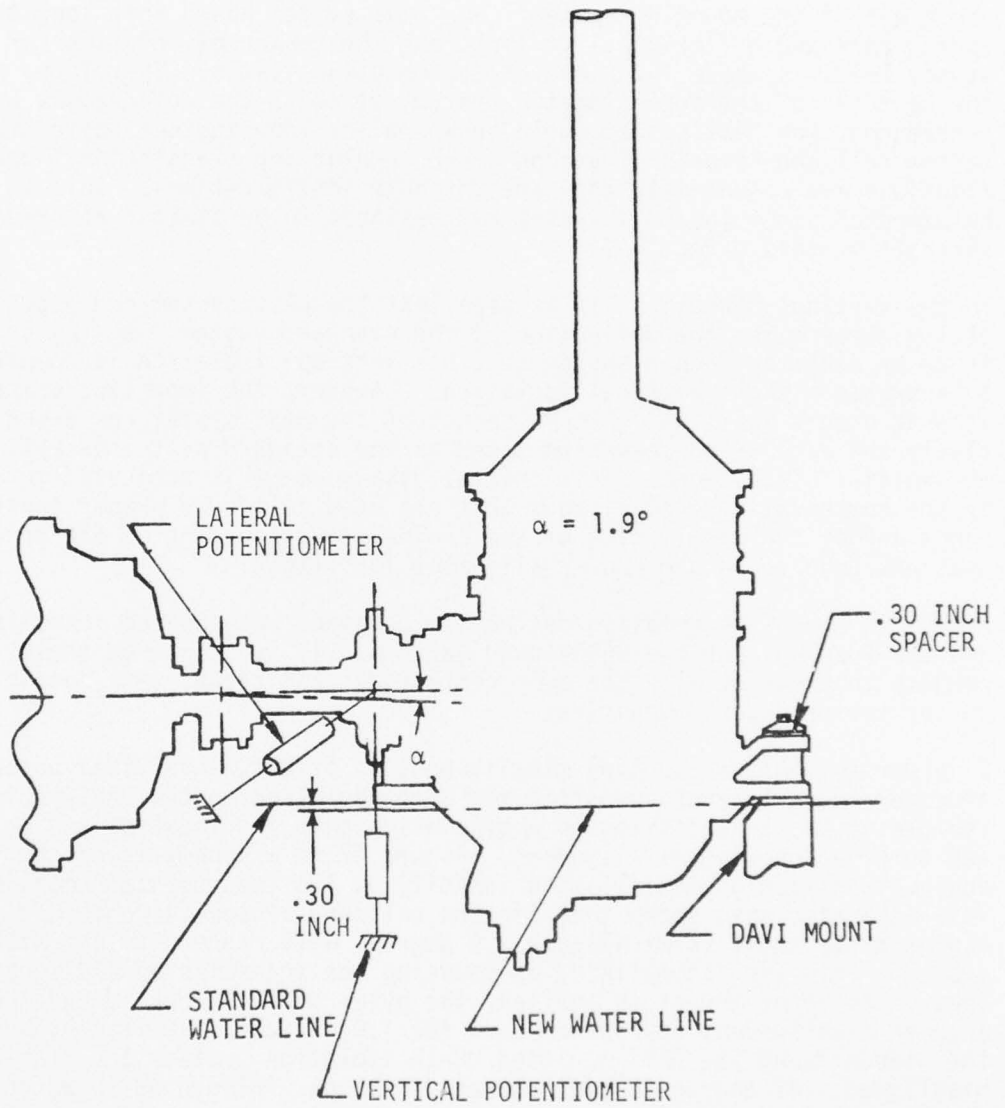

Figure 47. Transmission Mount Schematic

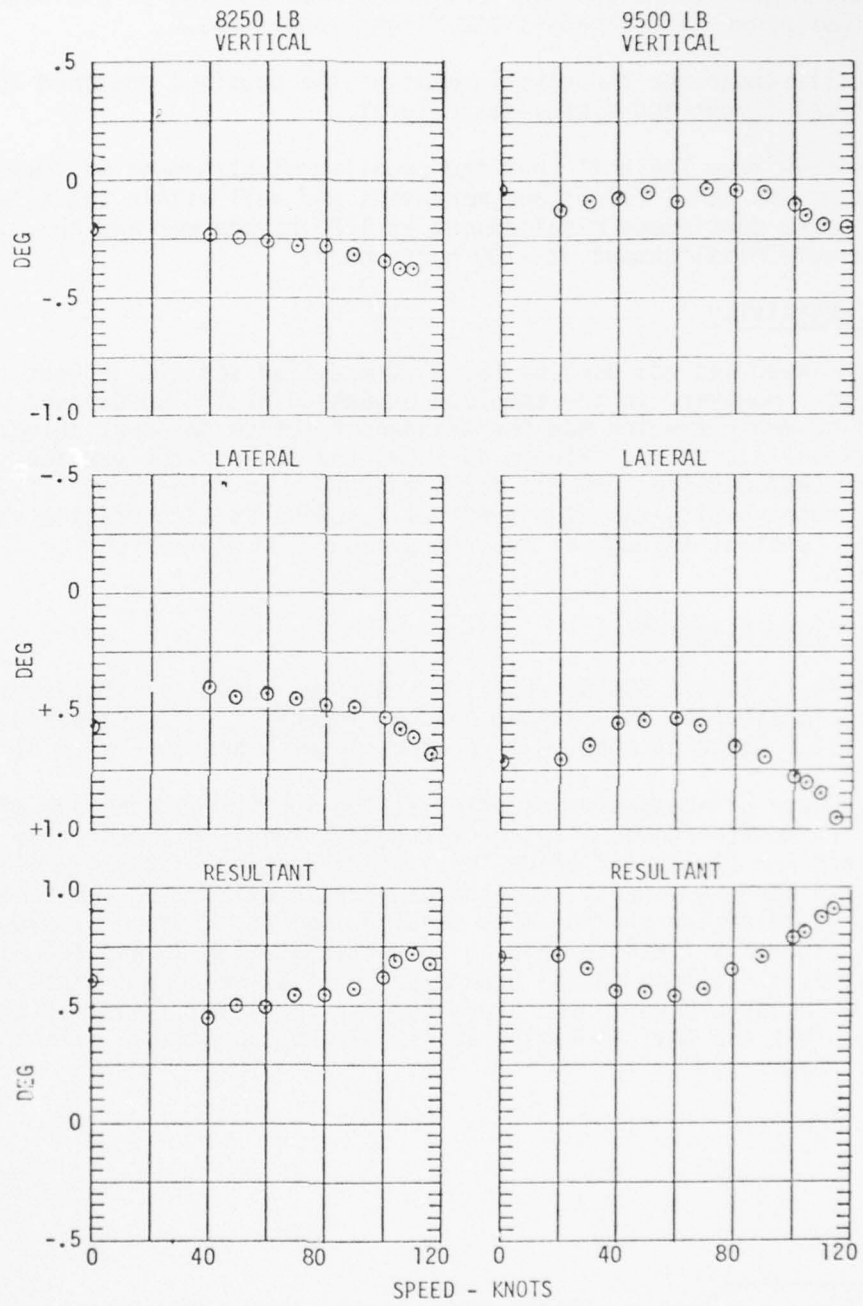

Figure 48. Angular Misalignment of the Engine Drive Coupling in the DAVI-Modified UH-1H

AD-A051 319

KAMAN AEROSPACE CORP BLOOMFIELD CONN
ADVANCED DEVELOPMENT OF A HELICOPTER ROTOR ISOLATION SYSTEM FOR--ETC(U)
DEC 77 R JONES
R-1396-2

F/6 1/3

DAAJ02-72-C-0082

NL

UNCLASSIFIED

USAAMRDL-TR-77-23B

2 OF 3
AD
A051319



OF 3
051319

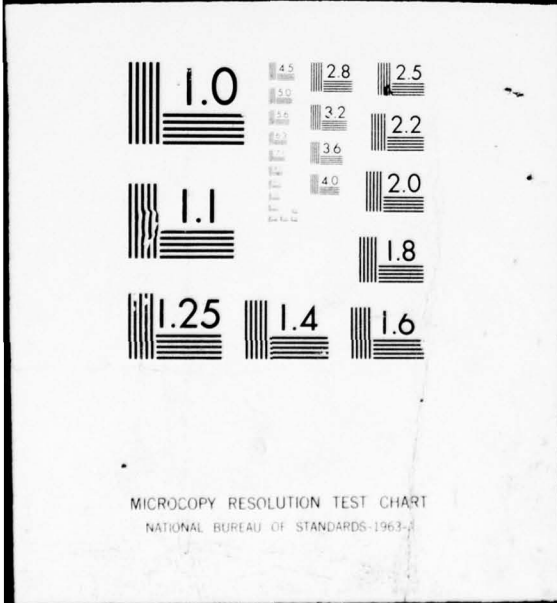

the 8250-pound and 9500-pound vehicles, respectively. This misalignment is well within the allowable continuous misalignment of 2.0 degrees at 1100 horsepower for steady-state flight conditions.

Table 11 summarizes the misalignment of the coupling obtained in straight and level flight and steady-state turns.

It is seen from Table 11 that the coupling misalignment was small for straight and level flight and maneuvers and well within the allowable 2.0-degree continuous misalignment at 1100 horsepower and the 3.0-degree two-minute misalignment at 1100 horsepower.

RPM Sensitivity

An rpm sweep was not done on the DAVI-modified vehicle without friction dampers. However, in the envelope expansion of the 9500-pound DAVI-modified vehicle which had the standard friction dampers, an rpm sweep was made at 70 knots. Figure 49 shows the two-per-rev vertical response of the DAVI-modified vehicle for a variation in rotor rpm. It is seen from these results that the vertical response at each station was essentially constant throughout the rpm sweep; little sensitivity with rpm is seen.

Rotor Blade Stresses

As shown in Figure 50, a reconstructed curve based on data extracted from Reference 14, the maximum bending moments for the standard UH-1H main rotor occur at station 0 for the flatwise and chordwise directions.

Strain gage bridges were installed at the sensitive locations of the rotor to monitor these stresses throughout the flight tests for the standard and DAVI-modified UH-1Hs. Blade station 35.0 was monitored for flatwise bending moments, and the drag brace axial load was monitored for the indication of chordwise bending moments. Figure 51 shows the total vibratory flatwise bending moment at Station 35 and the total vibratory axial load in the drag brace. It is seen from these results that no major change in the blade loading resulted. Thus, it is concluded that the DAVI isolation system has no appreciable effect on rotor blade loads.

¹⁴ Maloney and Akeley, DESIGN STUDY OF REPAIRABLE MAIN ROTOR BLADES, Kaman Aerospace Corporation; USAAMRDL Technical Report 72-12, U. S. Army Air Mobility Research and Development Laboratory, Fort Eustis, Virginia, July 1972, AD 749283.

TABLE 11. MEASURED COUPLING MISALIGNMENT

Condition	GW (lb)	Speed (kn)	Vertical (deg)	Lateral (deg)	Resultant (deg)	
Level Flight ↓	8250 ↓	0	-.21	.57	.61	
		40	-.24	.40	.47	
		50	-.25	.44	.51	
		60	-.26	.43	.50	
		70	-.28	.45	.53	
		80	-.28	.48	.56	
		90	-.32	.49	.58	
		100	-.34	.52	.62	
		110	-.36	.61	.71	
		116	-.38	.68	.78	
		Level Flight				
Right Turn		0	-.15	.65	.68	
		50	-.16	.52	.54	
Left Turn		50	-.35	.54	.64	
Right Turn		90	-.19	.60	.63	
Left Turn	8250	90	-.18	.64	.66	
Level Flight ↓	9500 ↓	0	-.03	.71	.71	
		20	-.13	.70	.71	
		30	-.09	.65	.66	
		40	-.07	.55	.55	
		50	-.05	.54	.54	
		60	-.09	.52	.53	
		70	-.04	.56	.56	
		80	-.05	.65	.65	
		90	-.06	.70	.70	
		100	-.10	.78	.79	
		105	-.15	.80	.81	
		110	-.18	.85	.87	
		116	-.20	.95	.97	
		Level Flight				
		Right Turn		0	-.23	.89
Right Turn		50	.07	.73	.73	
Left Turn		50	.04	.77	.77	
Right Turn		90	.08	.24	.26	
Left Turn	9500	90	-.01	.90	.90	

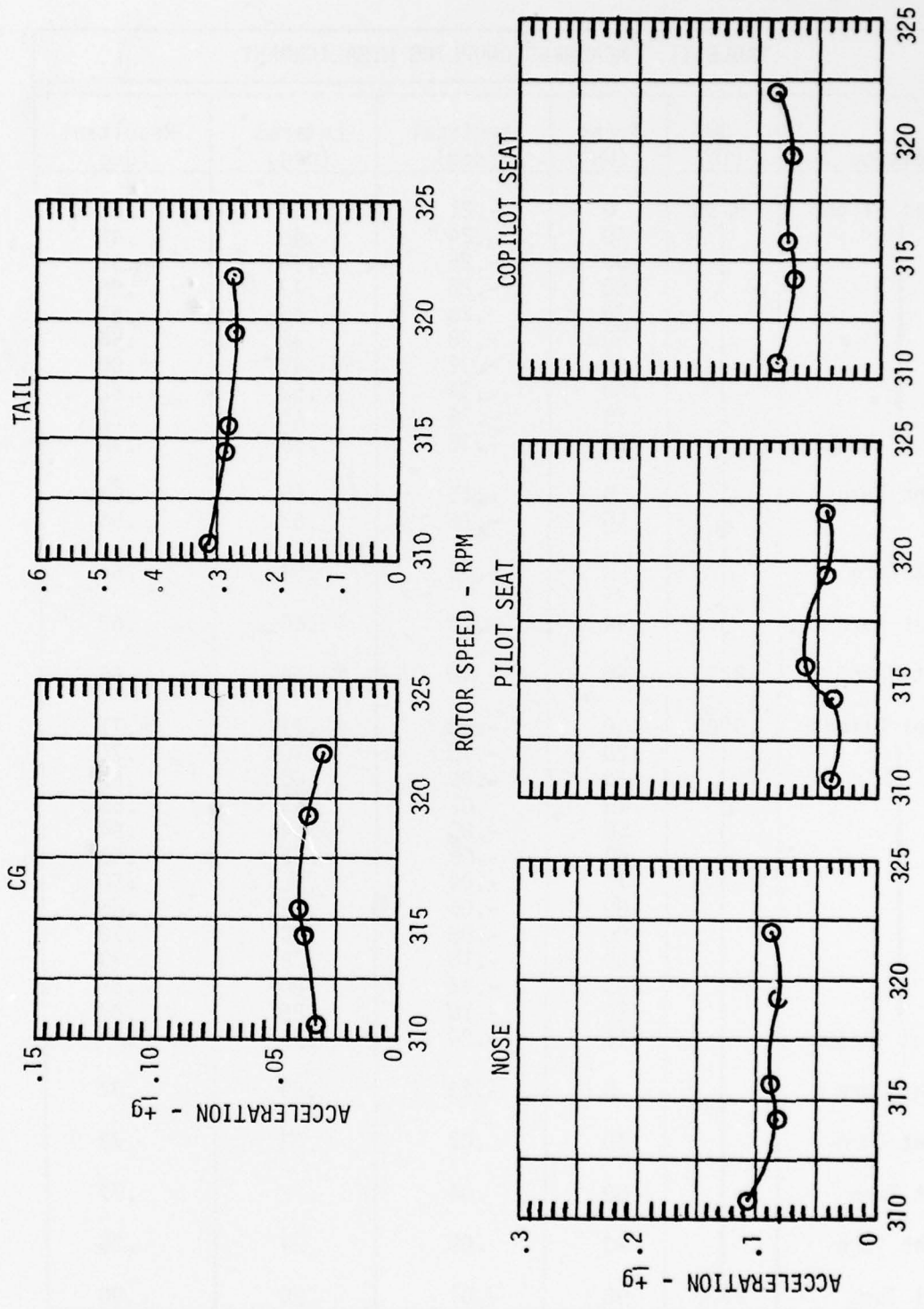

Figure 49. Two-Per-Rev Vertical Response of the 9500-Pound DAVI-Modified Vehicle

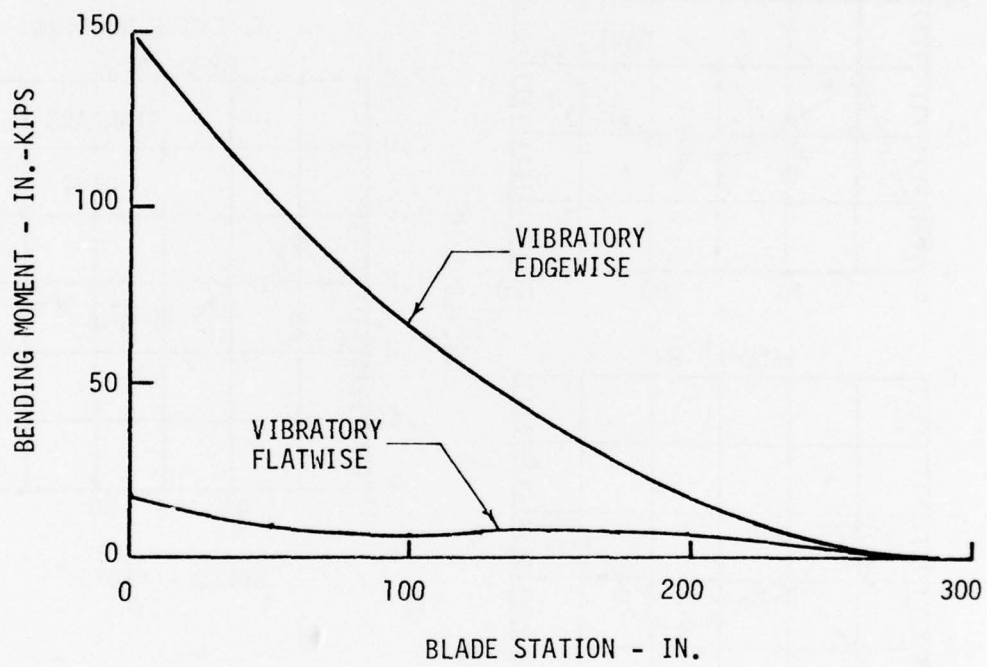

Figure 50. UH-1H Moment Distribution

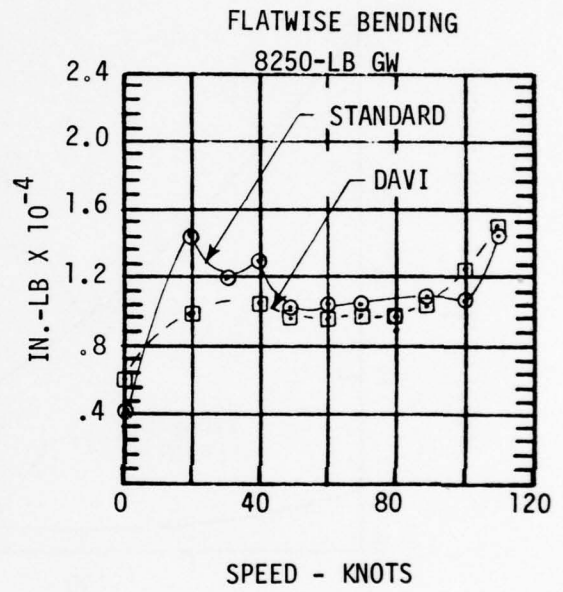
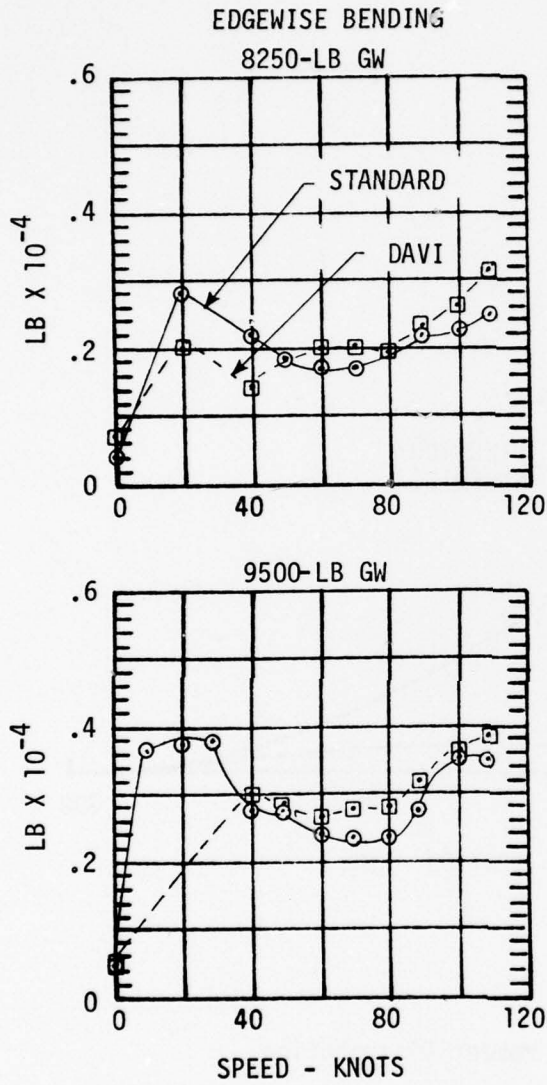

Figure 51. Main Rotor Blade Parameters

Blade Out-of-Track

A blade out-of-track test was done to determine the sensitivity of the DAVI isolation system to one-per-rev excitation. A similar blade out-of-track test was also done on the standard vehicle, and the responses of the vehicles were compared.

Blade out-of-track test for both configurations was accomplished by changing the length of the pitch link of the non-instrumented blade by one full turn so that the non-instrumented blade was high. No flagging of the rotor system was done to determine inches of out-of-track. Therefore, it is unknown if the blades had the same inches of out-of-track for both systems or the same magnitude of one-per-rev excitation. The rotor was retracted when installed on the DAVI system. This tracking was accomplished by a change in the blade tab setting, and in-track was established by pilot opinion. Therefore, it is unknown if the same pitch-link change on the rotor for both systems gave the equivalent amount of out-of-track.

Table 12 gives the one-per-rev responses of both systems for the out-of-track condition. For the DAVI-modified system, the 9500-pound gross weight vehicle was flown first, and a high level of one-per-rev vibration was obtained at 94 knots so that the pilot did not proceed to 100 knots. It is these values that are shown in the table for 100 knots. The 8250-pound vehicle was then flown, and a level of one-per-rev vibration was obtained at 84 knots so that the pilot did not proceed to 100 knots. The out-of-track condition was reduced to 1/2 turn, and data was obtained at 100 knots. Both values are shown in Table 12.

Based upon this data, the 8250-pound DAVI-modified vehicle appeared to be more susceptible to an out-of-track condition than the 9500-pound vehicle; whereas, as indicated by the data at 100 knots and by pilot opinion, the 9500-pound standard vehicle was more susceptible to an out-of-track condition than the 8250-pound vehicle.

It is seen from the data in Table 12 that the DAVI-modified system had a lower vibration level in hover for both gross weights than the standard system. However, at the 100-knot condition, a cross-over occurred and the DAVI system had a higher one-per-rev vibration level than the standard system. This cross-over with speed may be due to the changing of phases of the one-per-rev forcing functions or due to the fact that, because of the change in basic track of the two systems, the one turn of the pitch link did not give the same effective out-of-track.

Because of the many variables encountered in the out-of-track test it is impossible to draw valid conclusions.

TABLE 12. ONE-PER-REV VIBRATORY RESULTS FOR THE
OUT-OF-TRACK CONDITIONS

Transducer Location and Magnitude - +g													
Speed (knots)	GW	Trnsdcr Dir	Nose		Pilot Seat		Copilot Seat		C6		Tail		
			Std	DAVI	Std	DAVI	Std	DAVI	Std	DAVI	Std	DAVI	
0	8250	VT	.053	.015*/.032**	.030	.013/.034	.056	.007/.011	.013	.003/.009	.266	.043/.097	
		LT	.024	.015/.034	.017	.008/.021	.016	.008/.020	.010	.002/.003	.161	.050/.175	
		LONG.	.020	.005/.008	.012	.003/.008	.014	.004/.008	.012	.002/.008	.130	.021/.038	
0	9500	VT	.023	.021	.019	.019	.025	.013	.008	.005	.197	.117	
		LT	.129	.091	.074	.052	.076	.053	.015	.007	.530	.394	
		LONG.	.014	.010	.019	.014	.028	.020	.011	.008	.106	.056	
100	8250	VT	.173	.170*/.366**	.144	.134/.277	.129	.116/.239	.053	.051/.095	.498	.448/.904	
		LT	.077	.090/.204	.043	.047/.107	.043	.048/.113	.018	.010/.020	.393	.442/.962	
		LONG.	.026	.024/.052	.012	.022/.040	.013	.008/.023	.004	.004/.008	.209	.192/.411	
100***	9500	VT	.202	.328	.175	.266	.145	.227	.052	.093	.605	.893	
		LT	.129	.207	.071	.112	.073	.115	.021	.024	.625	1.066	
		LONG.	.032	.047	.023	.041	.022	.022	.007	.005	.245	.397	

* Data obtained with 1/2 turn out-of-track; 100 knots.

** Data obtained with 1 turn out-of-track; 84 knots.

*** Data obtained with 1 turn out-of-track; 94 knots.

Main Rotor Change

The main rotor and the hub from the UH-1H helicopter no. 68-14601, which had blade numbers TVA-4570 and A2 21080, was installed on Ship No. 66-1093, the test vehicle. The main reason for the change in rotors was to determine the effects of the change on vibration levels. Although no vibration data had been obtained on Ship No. 68-16401, in the opinion of the pilots, this rotor was a smoother rotor, especially in one-per-rev characteristics, than the rotor that came on Ship No. 66-1093. Figures 52 through 60 show the results of this comparison.

Figures 52 through 54 show the one-per-rev responses of the DAVI-modified vehicle where rotor A is the original rotor on Ship No. 66-1093, the test vehicle, and rotor B is the rotor from Ship No. 68-16401. It is seen from these figures that the DAVI-modified vehicle had a lower one-per-rev vertical response in hover and at high speeds with the original rotor than with the changed rotor. In the lateral direction, the vibratory responses of the DAVI-modified vehicle with these rotors were essentially the same. In the longitudinal direction, the vibratory response of the DAVI-modified vehicle with either rotor was negligible except at the tail location. At the tail location, the DAVI-modified vehicle had a lower response in hover and high speed with the original rotor than with the changed rotor.

Although the DAVI-modified vehicle with the changed rotor had a higher vertical one-per-rev response than the DAVI-modified vehicle with the original rotor, no tracking of the rotor was done. However, in the opinion of the pilots, the DAVI-modified vehicle with the changed rotor was less susceptible to one-per-rev variations.

Figures 55 through 57 show the two-per-rev responses of the DAVI-modified vehicle where rotor A is the original rotor and rotor B is the changed rotor. It is seen from these figures that in all directions and locations the DAVI-modified vehicle with either rotor had essentially the same responses.

Figures 58 through 60 show the four-per-rev responses of the DAVI-modified vehicle with rotor A and rotor B. It is seen from these figures that in all directions and locations similar four-per-rev responses were obtained. In the vertical direction, the DAVI-modified vehicle with the changed rotor did have lower responses at the low speed at the nose, pilot seat, and tail locations than the DAVI-modified vehicle with the original rotor.

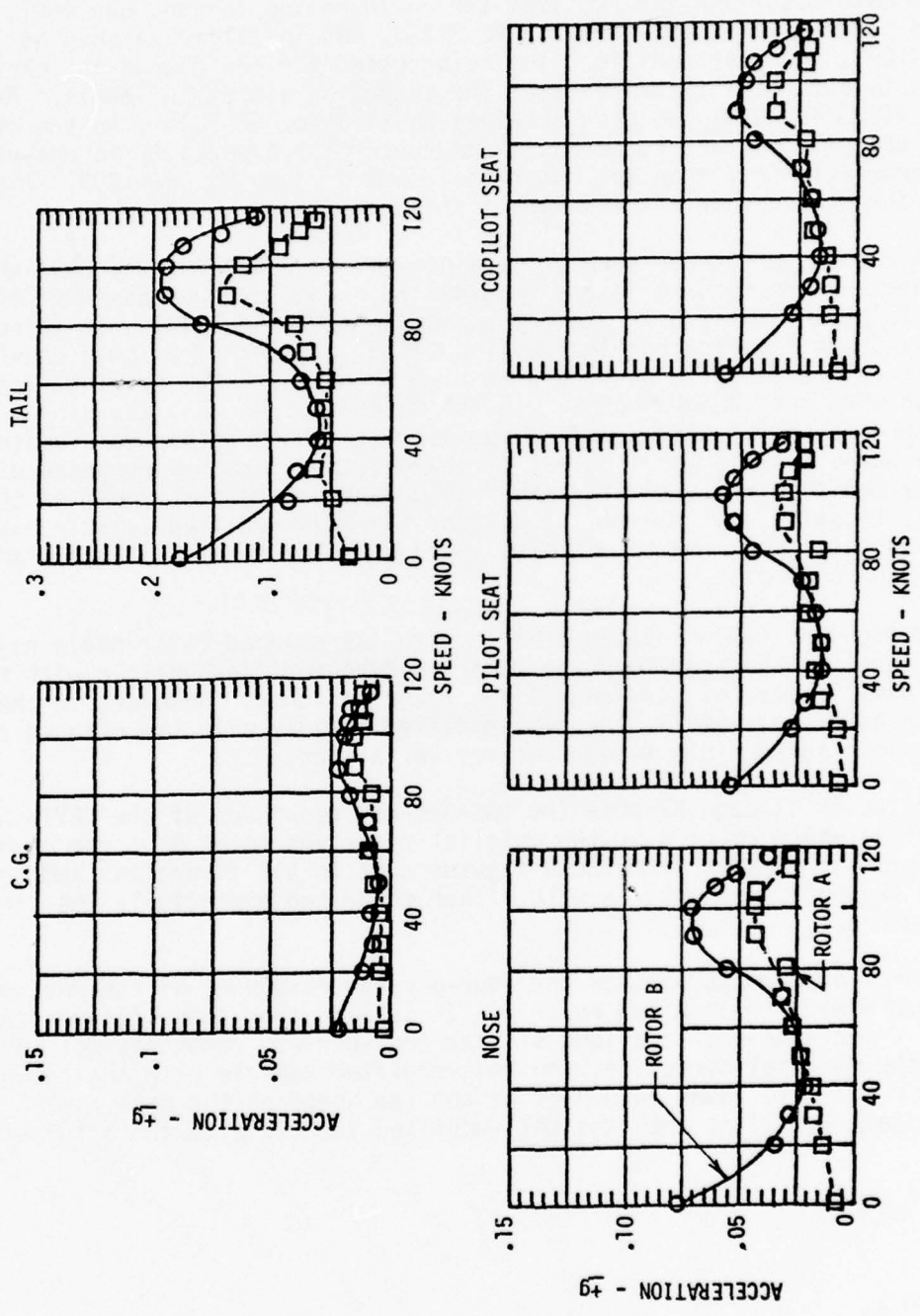

Figure 52. One-Per-Rev Vertical Response of the DAVI-Modified Vehicle

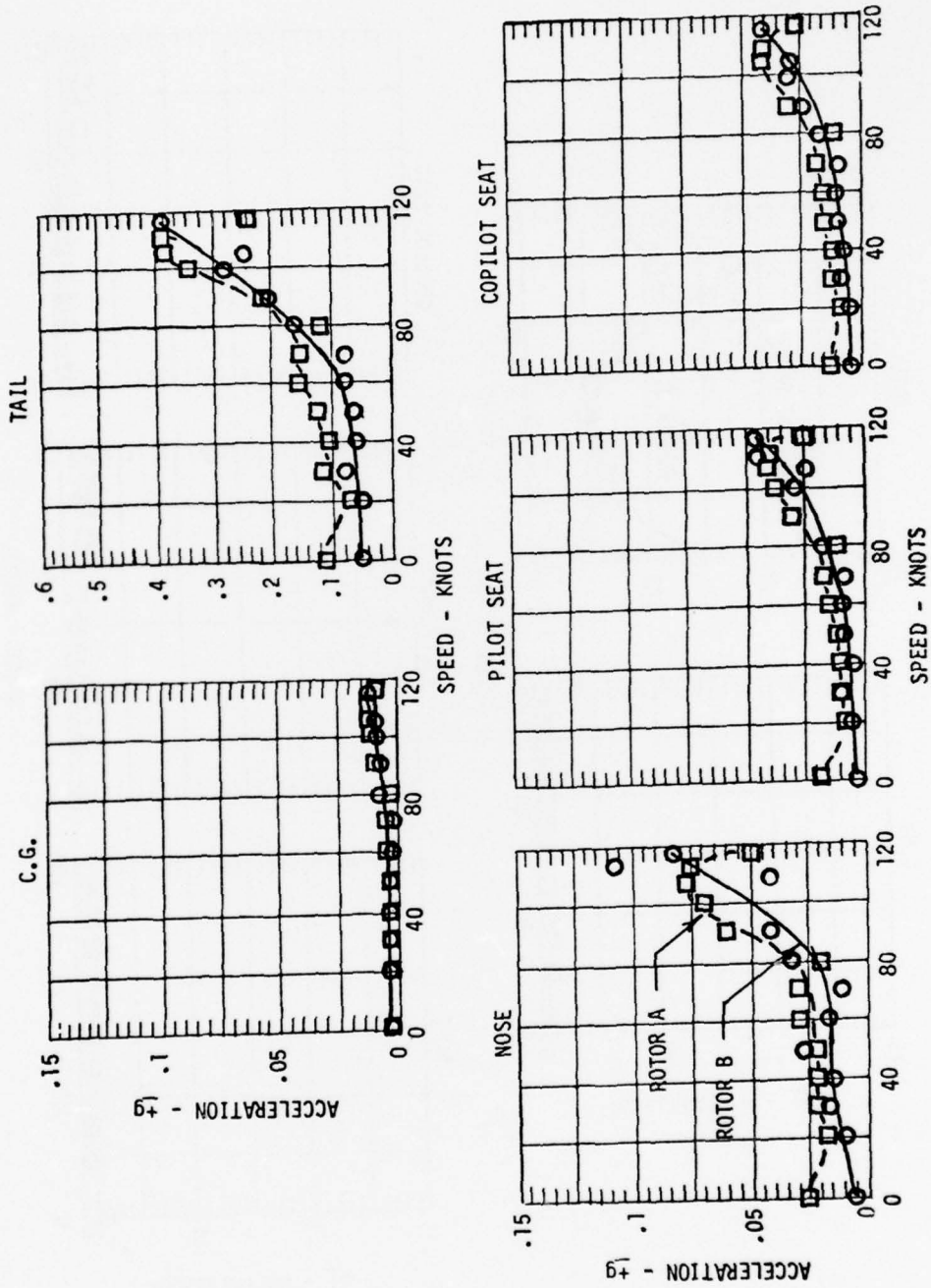

Figure 53. One-Per-Rev Lateral Response of the DAVI-Modified Vehicle

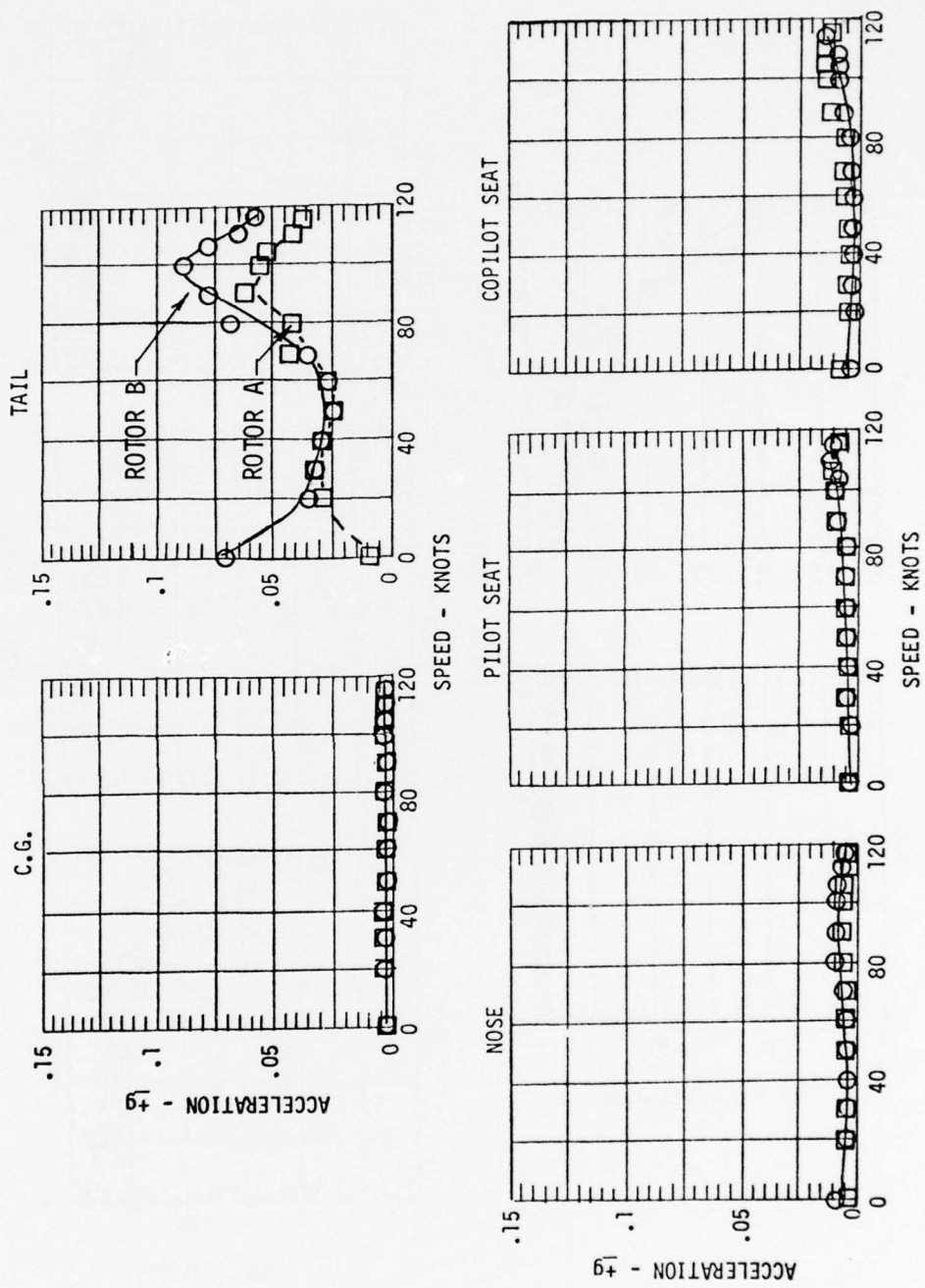

Figure 54. One-Per-Rev Longitudinal Response of the DAVI-Modified Vehicle

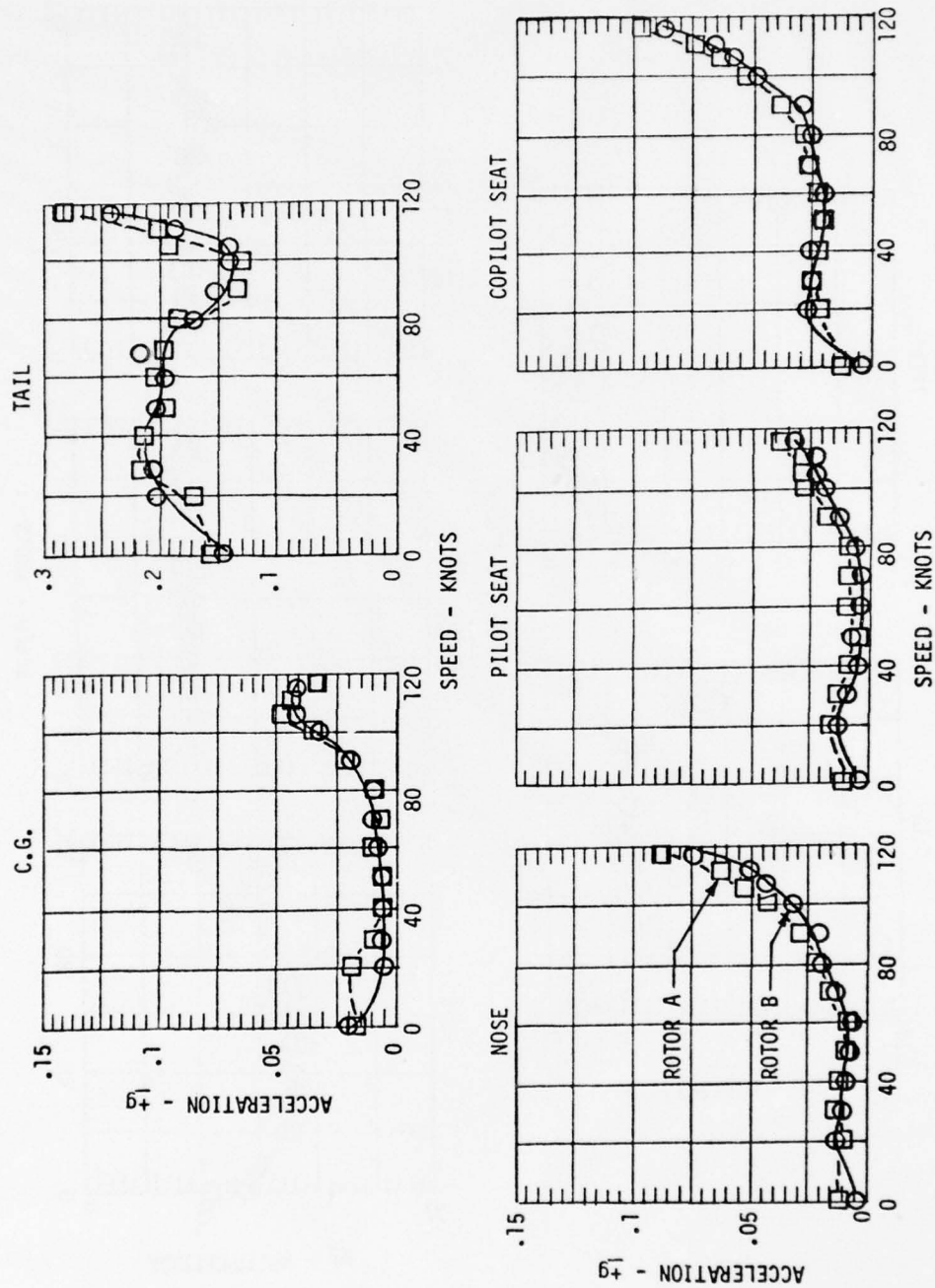

Figure 55. Two-Per-Rev Vertical Responses of the DAVI-Modified Vehicle

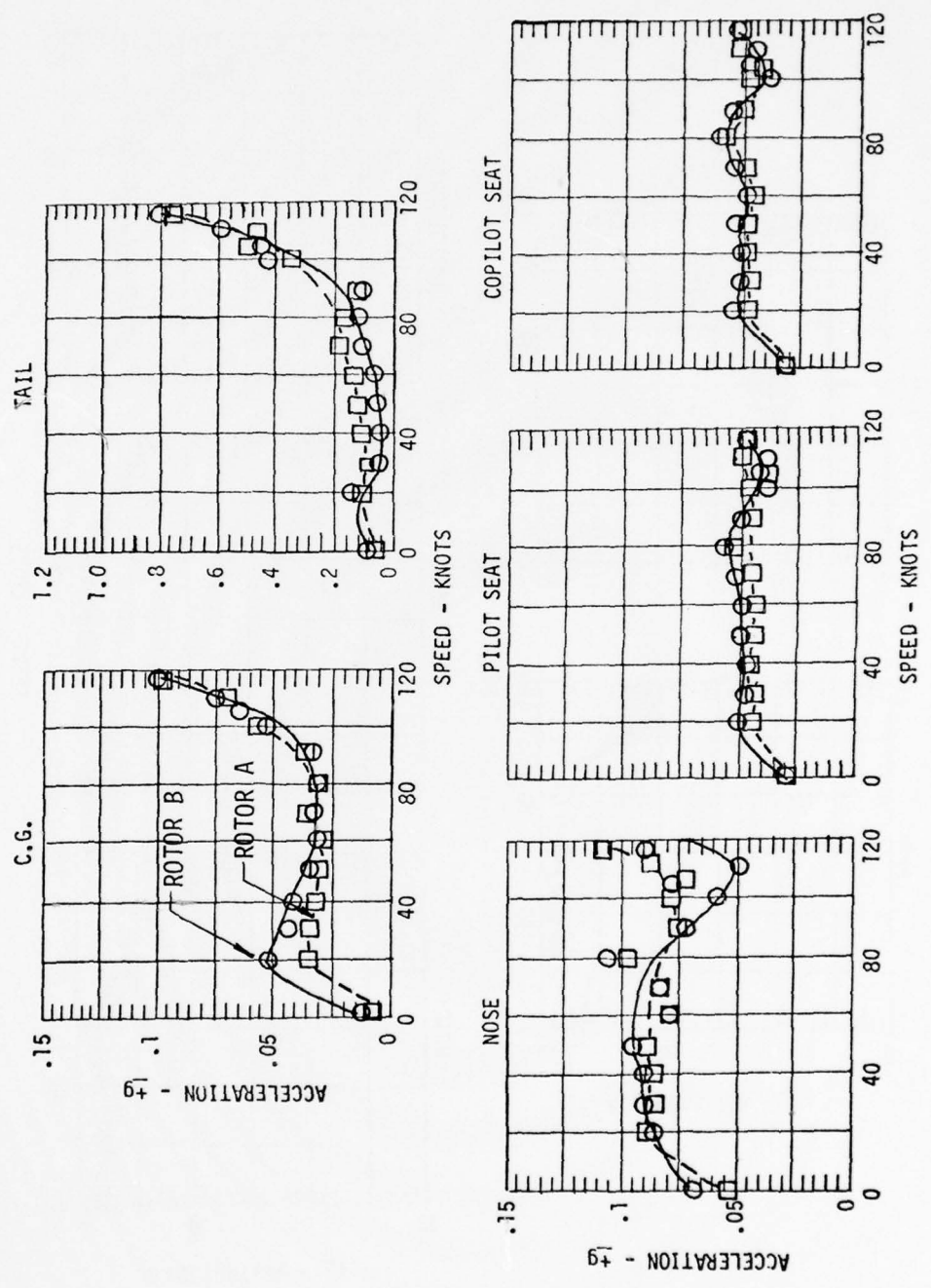

Figure 56. Two-Per-Rev Lateral Responses of the DAVI-Modified Vehicle

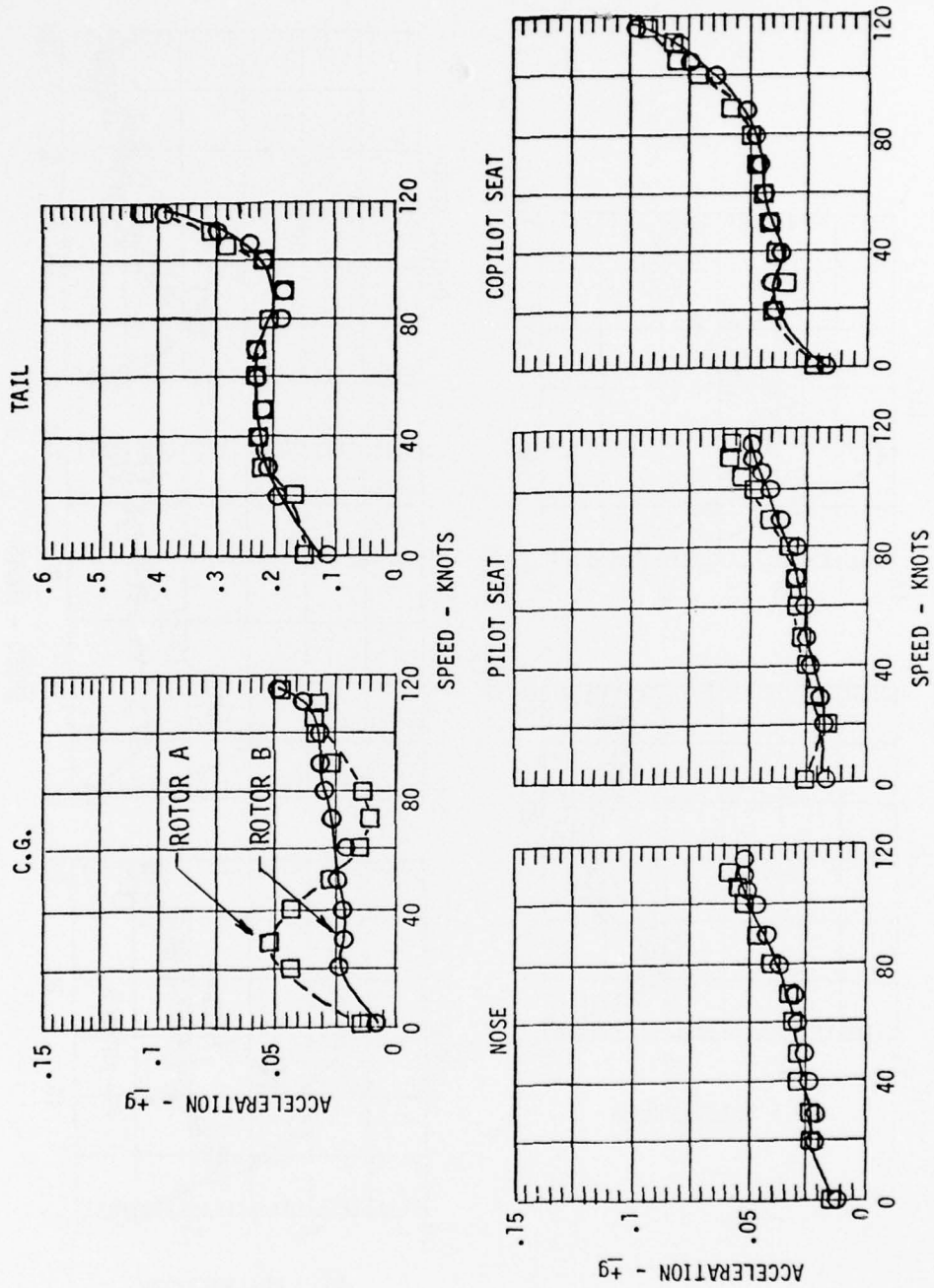

Figure 57. Two-Per-Rev Longitudinal Responses of the DAVI-Modified Vehicle

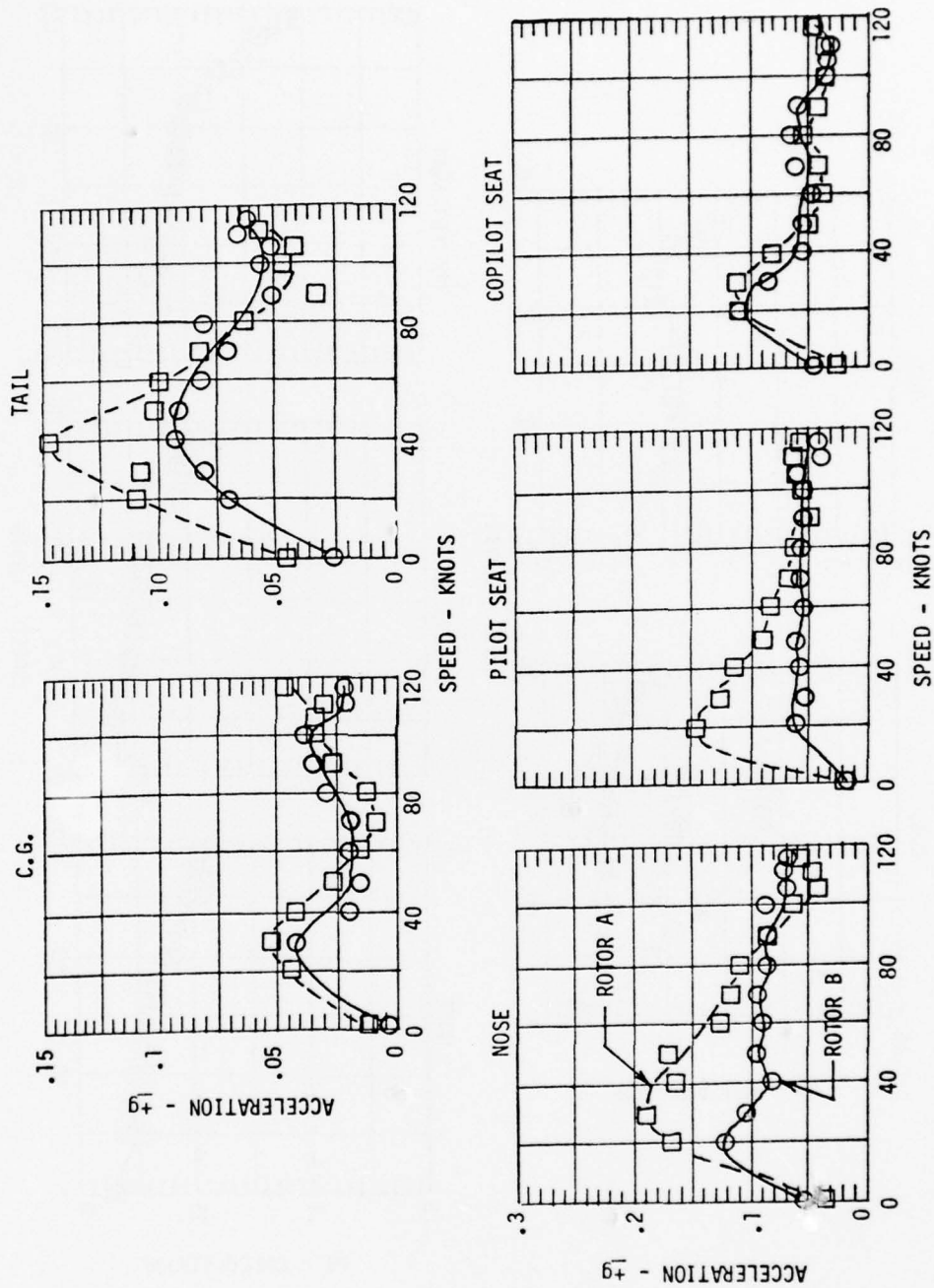

Figure 58. Four-Per-Rev Vertical Responses of the DAVI-Modified Vehicle

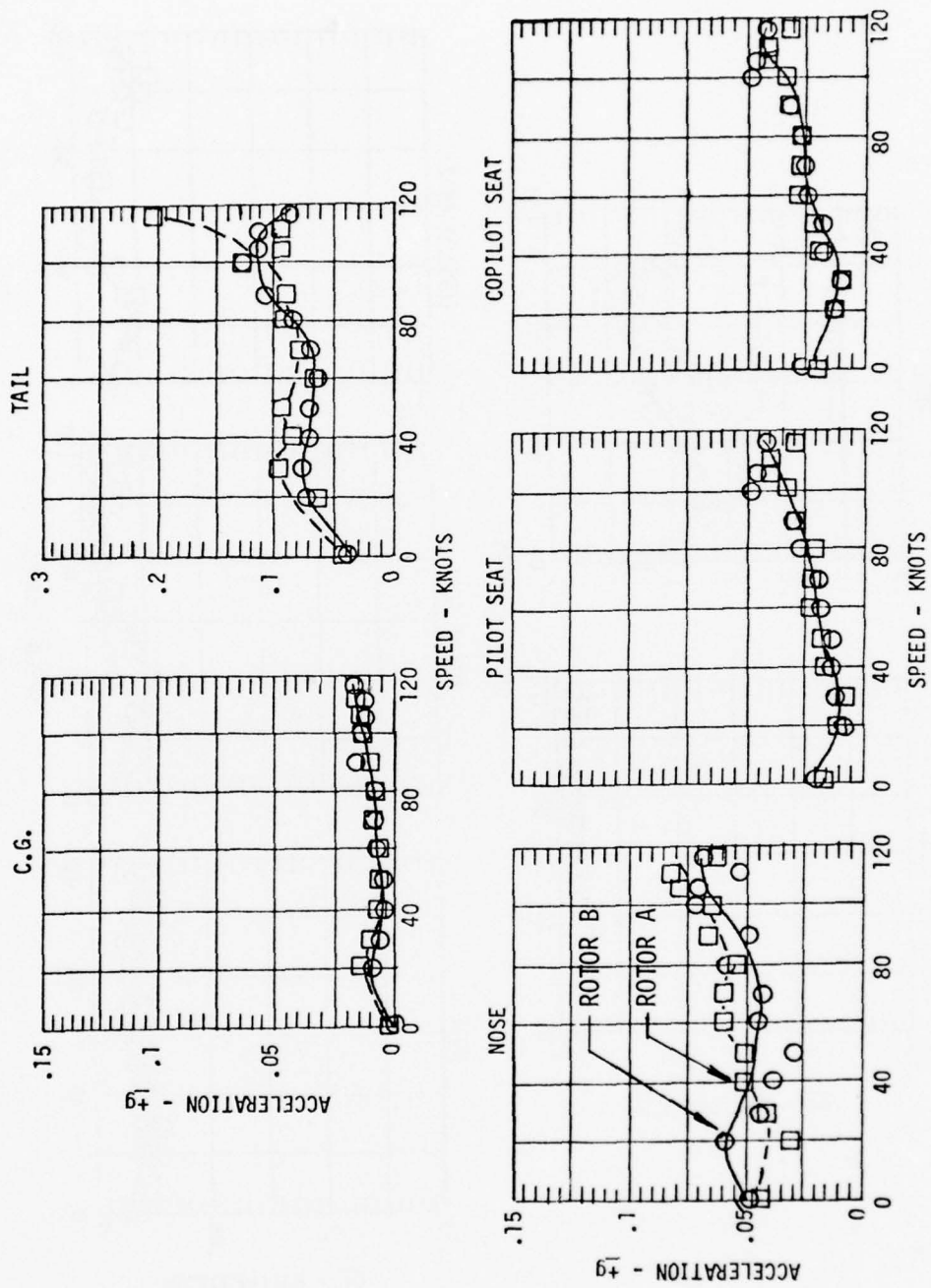

Figure 59. Four-Per-Rev Lateral Responses of the DAVI-Modified Vehicle

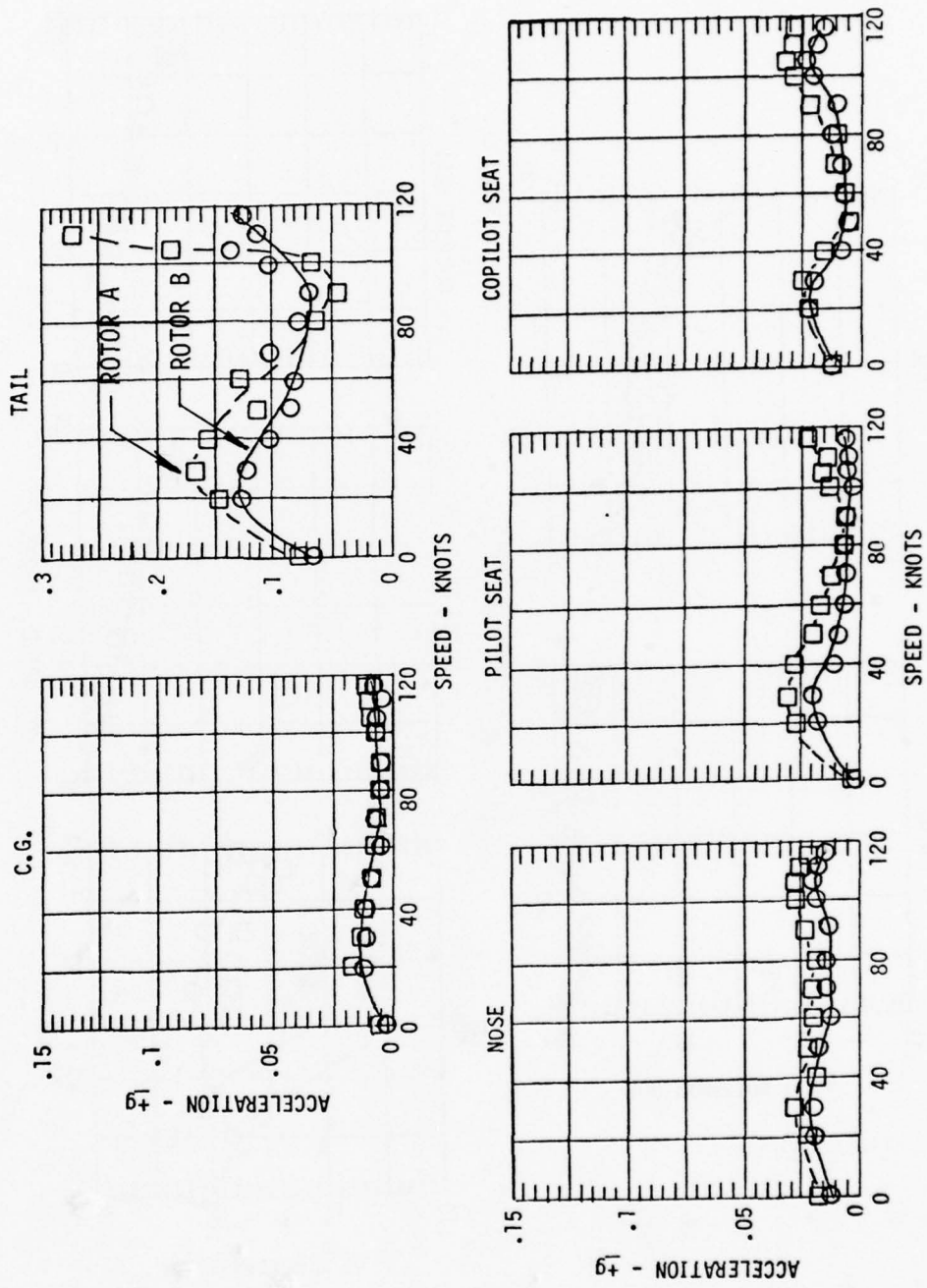

Figure 60. Four-Per-Rev Longitudinal Responses of the DAVI-Modified Vehicle

ISOLATION SYSTEM DESCRIPTION

DESIGN PHILOSOPHY

The ideal isolation system should isolate the fuselage for all six rigid-body modes of motion from the major rotor-induced n/rev excitaton. These six rigid body modes of motion are:

1. First mode of pitch and longitudinal translation
2. Second mode of pitch and longitudinal translation
3. First mode of roll and lateral translation
4. Second mode of roll and lateral translation
5. Vertical translation
6. Yaw

This can be accomplished with a conventional passive system by using a very soft spring rate. However, in the design of an isolation system, the following major problems must be considered:

1. Excessive Deflection
 - a. Drive system coupling problems
 - b. Flying quality problems
2. Mechanical Instability and Flywheel Resonance
3. Rotor, Transmission, Engine Torsional Instability

Depending upon the type of rotor system used, the priority of the above three problem areas may differ. However, excessive deflection is common to all. For example, the UH-1 helicopter has a predominant excitation frequency at 10.8 Hertz. To obtain vertical isolation at this 2/rev frequency and no amplification at 1/rev requires that a conventional isolation system have a static deflection of approximately 0.7 inch, which will give excessive deflection in maneuvers.

Mechanical instability is a coupling between the inplane blade motions and the inplane hub motions of the isolation system and/or of the helicopter on its landing gear. The center of mechanical instability, which is the point at which the instability is most critical, is given by the following relationship:

$$\omega_n + \omega_B = \Omega_{M.I.} \quad (1)$$

in which

ω_n = inplane natural frequencies of the isolation system and/or of the helicopter on its landing gear

ω_B = inplane blade natural frequencies

$\Omega_{M.I.}$ = rotor speed for center of mechanical instability

For semirigid rotor systems used on the UH-1 helicopter in which the inplane natural frequencies of the blades are above one-per-rev of the rotor speed, mechanical instability is not a problem. For fully articulated rotor systems, in which the natural frequency of the rigid mode of the blade due to lag-hinge offset is well below one-per-rev, either the isolation system must be designed to have natural frequencies above one-per-rev or damping must be used to control the instability.

For two-bladed helicopters, flywheel resonance can be a problem in that there is an unstable range associated with this phenomenon. Therefore, care must be taken in the design of the isolation system not only to prevent amplification at one-per-rev, but also to insure that there is no flywheel instability in the operating range of the rotor.

Also, the problem of rotor/engine torsional instability differs with the type of rotor system. This instability is a function of the torsional stiffness, the inplane damping of the rotor system and the engine fuel control. Although a fully articulated rotor system has a very low natural frequency in torsion due to the lag motion of the blades, it also has mechanical lag dampers in the system, which add stability. Therefore, control of this instability does not usually require a complex engine fuel-control system.

The semirigid or hingeless rotor system blades have very high inplane natural frequencies, but the system does not have mechanical lag dampers. However, the UH-1 has a long rotor driveshaft and, therefore, has a relatively soft spring rate in torsion. This, then, requires a very stiff isolation system in yaw to compensate for the shaft torsional spring rate. This type of rotor system usually requires a more complex engine fuel-control system to provide stability to achieve rotor/engine compatibility.

The UH-1 standard rotor isolation system is designed to be structurally rigid in the vertical direction, to be soft inplane to obtain two-per-rev isolation, and to have a flywheel resonance well below the rotor operating range. It is relatively stiff in the yaw mode for satisfactory rotor/engine stability.

The DAVI isolation system for the UH-1 has been designed to be relatively stiff in the vertical direction to minimize the excessive vertical deflection, and is designed to have identical characteristics in the in-plane and torsional directions to the standard UH-1 helicopter, to avoid any of the aforementioned problems.

STANDARD UH-1H ISOLATION SYSTEM

The UH-1H helicopter is presently isolated as shown schematically in Figure 10. This isolation system is a five-point mounting system designed to isolate the fuselage from the inplane forces of the rotor. Therefore, the five tubular elastomeric mounts are soft in the vertical direction, and the four transmission mounts are stiff inplane to react torque, while the fifth mount is pinned so that it does not react the torque. The UH-1 has a rigid lift-link to react the vertical load; thus no vertical isolation is achieved. Table 13 gives the known spring rates of the system.

TABLE 13. SPRING RATES OF THE UH-1 ISOLATION SYSTEM		
Mount	Spring Rate - Lb/In.	
	Vertical	Inplane
1, 2, 3, 4	4,500	25,500
5	3,200	0

DAVI ISOLATION SYSTEM

In order to insure the minimum structural modification and the integrity of similar load paths in the modified helicopter, one basic structural design ground rule was that the DAVI isolators should be located at the same mounting points as in the standard system. Preliminary analysis of various DAVI systems showed that a five-point DAVI isolation system gave the best results. Figure 11 shows a schematic of this system. In comparing this isolation system with the standard system, it is seen that:

1. The standard four transmission mounts are replaced with four two-dimensional DAVI mounts.
2. The standard fifth mount is eliminated.
3. The standard lift link is replaced by a unidirectional DAVI.

Thus, in this system, DAVI isolation is obtained in the vertical, longitudinal and pitching directions, conventional isolation is obtained in the lateral direction, and a combination of conventional and DAVI isolation is obtained in the rolling direction.

In approaching the task of modifying an existing, successful helicopter in which the dynamic characteristics are well known, it is best to have similar characteristics wherever possible in the modification. Therefore, two basic dynamic ground rules were followed:

1. The DAVI system was designed to have the same mechanical instability and flywheel resonance characteristics as the conventional system.
2. The torsional restraint of the DAVI system was designed to have characteristics similar to those of the standard system to insure rotor and engine torsional compatibility.

Table 14 shows the required spring rates of the DAVI system to achieve this design goal.

COMPARATIVE ANALYTICAL RESULTS

Table 15 gives the natural frequencies of both systems for the six rigid-body modes of motion. It is seen from Table 15 that, for the first rigid body modes of pylon pitching and rolling, the natural frequencies of the systems are essentially the same. Since it is these modes that determine the critical flywheel resonance and mechanical instability ranges, both systems should have similar dynamic characteristics. Also it is seen that the yawing frequencies of both systems are identical, and therefore, the torsional characteristics should be similar. The DAVI system did introduce natural frequencies between one-per-rev and two-per-rev for vertical translation, and the second mode of longitudinal translation and pitch. For the second mode of lateral translation and roll, both systems have a relatively high natural frequency.

In order to compare the relative stiffnesses of the mounting systems, effective spring rates of the system were calculated for longitudinal, lateral, vertical, pitching, rolling, and torsional directions. The longitudinal, lateral, and vertical spring rates are sums of the spring rates in the appropriate directions. The pitching spring rate was obtained about Butt Line 0, and the torsional spring rate is obtained about the centroid of the four transmission mounts. The spring rates, as given in Tables 13 and 14, were used in these calculations. Table 16 shows the results of these calculations.

TABLE 14. DESIGN SPRING RATES OF THE DAVI ISOLATION SYSTEM			
Mount	Spring Rate - Lb/In.		
	Vertical	Longitudinal	Lateral
Transmission (Four)	6,500	6,500	53,000
Lift Link	10,000	0	0

TABLE 15. CALCULATED NATURAL FREQUENCIES OF THE SYSTEMS		
Mode	Frequency - Hertz	
	Standard	DAVI
First Longitudinal Translation and Pitch	3.23	3.00
First Lateral Translation and Roll	3.61	4.01
Yaw	6.15	6.15
Vertical Translation	85.14	8.95
Second Longitudinal Translation and Pitch	41.97	9.34
Second Lateral Translation and Roll	42.85	59.67

TABLE 16. EFFECTIVE SPRING RATES OF THE STANDARD AND DAVI UH-1 ISOLATION SYSTEMS

Direction	Spring Rates	
	Standard	DAVI
Vertical	Structurally Rigid	36,000 lb/in.
Longitudinal	102,000 lb/in.	26,000 lb/in.
Lateral	102,000 lb/in.	212,000 lb/in.
Pitch	3,507,560 in.-lb/rad	3,484,520 in.-lb/rad
Roll	2,790,045 in.-lb/rad	4,030,065 in.-lb/rad
Torsion	27,928,875 in.-lb/rad	29,217,785 in.-lb/rad

It is seen from Table 16 that the DAVI system is softer in the vertical and longitudinal directions than the standard system. However, in the remaining four directions, the DAVI is as stiff or stiffer than the standard system.

DESIGN

CRITERIA

Fuselage Structural Modification

The design criteria used for the structural modification required for the installation of the DAVI system in the UH-1H helicopter were the same as used in the standard design. These critical flight conditions used for the design were obtained from References 15 and 16 and are given in Table 17.

TABLE 17. DESIGN CRITERIA	
Design Gross Weight: 6600 Pounds	
Condition No.	Maneuver
II	3.0 g Symmetrical Pull-Out, Forward CG
Vb	2.4 g Rolling Pull-Out, Tail Rotor Thrust Right, Forward CG
Vc	2.4 g Rolling Pull-Out, Tail Rotor Thrust Left, Forward CG
VI	1.0 g Yawing Maneuver, Forward CG
VIII	Level Landing With Drag, Limit Drop, Forward CG
XIV	Level Landing With Right Drift, Limit Drop, Forward CG
Crash Landing Conditions*	
Direction	Load Factor
Vertical	<u>+8.0</u> g (up and down)
Longitudinal	8.0 g (forward)
Lateral	<u>+8.0</u> g (left and right)
* For the above crash load factor criteria, no attempt shall be made to provide a non-yielding structure at 2/3 ultimate load.	

¹⁵ FUSELAGE STRUCTURAL ANALYSIS, VOLUMES I THROUGH IV, Bell Helicopter Company, Fort Worth, Texas, Bell Report 205-009-007, 28 February 1969.

¹⁶ EXTERNAL DESIGN LOADS, VOLUME III, Bell Helicopter Company, Fort Worth, Texas, Bell Report 205-099-006, 6 March 1969.

DAVI Isolators

The DAVI isolator components were designed to the Design Criteria given in Table 17, and the travel requirement within each DAVI mount before bottoming was determined for rotor load factors of 3.00g and -.5g, for the design gross weight of 6600 pounds and for a ramp of 0.6 second.

Control System

The original control system design change was limited to an idler system to permit the vertical travel requirements of the DAVI system. However, design review meetings between Kaman, Bell Helicopter Corporation, and the Army technical monitor developed the requirements to isolate the control system boost actuators by moving them to the transmission support base, thereby isolating vibratory control loads. No criteria were specified since the design was to be the same as an earlier Bell Helicopter experimental design. But, Bell Helicopter Corporation was only able to locate two drawings of the original design, so Kaman completed the remainder of the design to the original UH-1 Design Criteria in Table 17.

GENERAL ISOLATION SYSTEM DESCRIPTION

Standard UH-1H Isolation System

The standard UH-1 isolation system consists of five elastomeric mounts and a rigid lift link as shown schematically in Figure 10 and in more detail in Figures 61 and 62. Figure 61 shows the arrangement of the mount attachment to the transmission, and Figure 62 shows the mount attachment to the shelf structure of the fuselage. Conventional tubular elastomeric mounts are located at each transmission corner and a fifth conventional tubular mount is located at Butt Line 0. Each of these corner tubular mounts works in shear of the elastomer in the vertical direction and in compression in the longitudinal and lateral directions. The fifth mount works in shear in the vertical direction and is pinned in the lateral and longitudinal directions. The lift link is a rigid forged link, pinned at the transmission and fuselage attachments, and reacts most of the vertical load. The transmission pitches and rolls about or near the lift link attachments.

DAVI Isolation System

The revised DAVI isolation system is shown schematically in Figure 11 and in more detail in Figures 63, 64, and 65. Figure 63 shows the arrangement of the DAVI mount attachments to the fuselage. It is seen from this figure that the DAVI transmission mounts are at the same locations as in the standard system, the fifth mount has been eliminated, and the lift link has been replaced by a unidirectional DAVI. It is further seen that the friction dampers have been removed from under the aft transmission mounts, where they are located in the standard configuration, to aft of the mounts for the DAVI configuration. Also, to insure fore and aft crash integrity, fore and aft crash-restraint straps have been added between the outer housing of the DAVI, attached to the transmission, and the modified shelf structure of the fuselage.

BEST AVAILABLE COPY

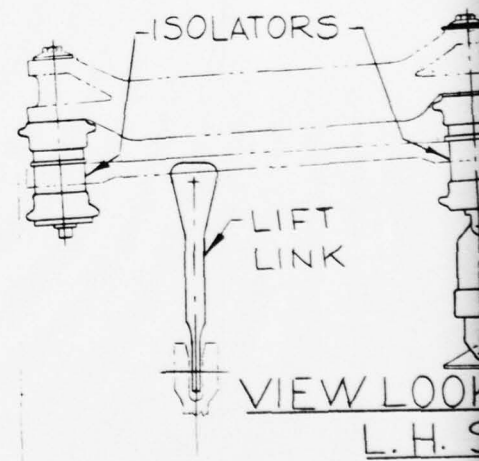
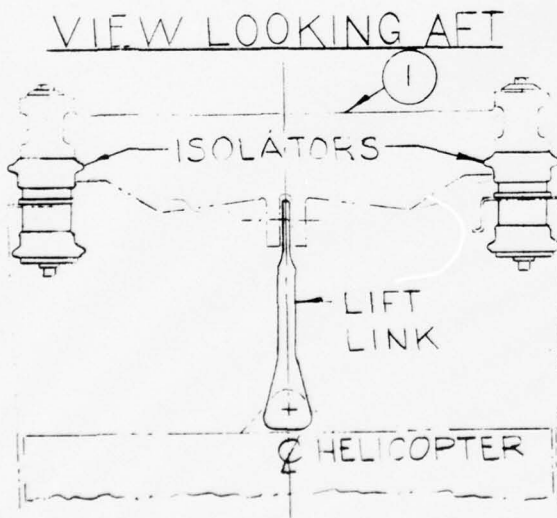
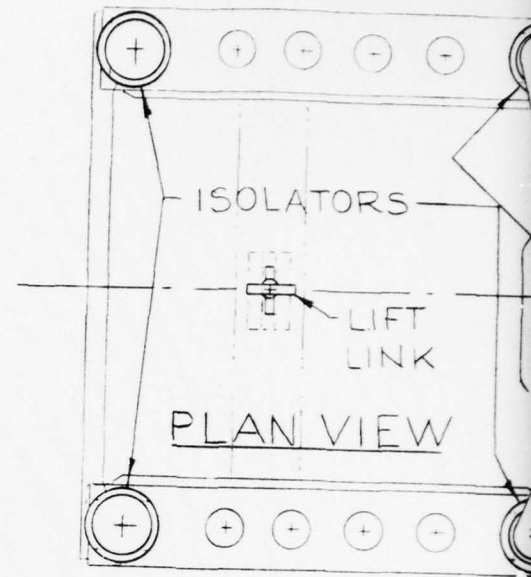
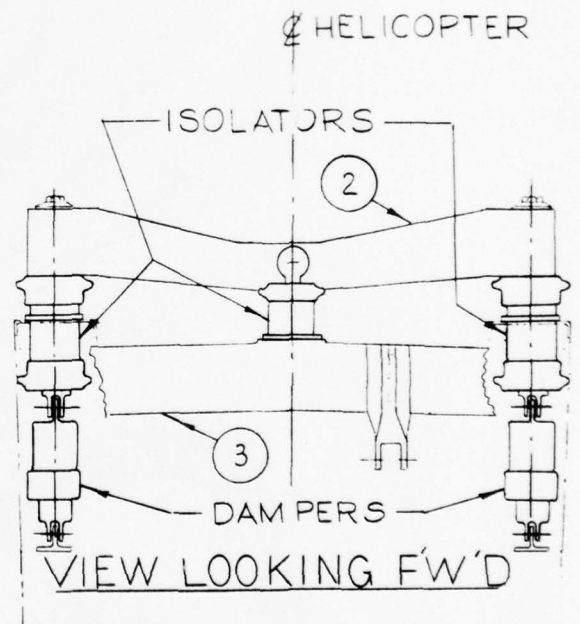
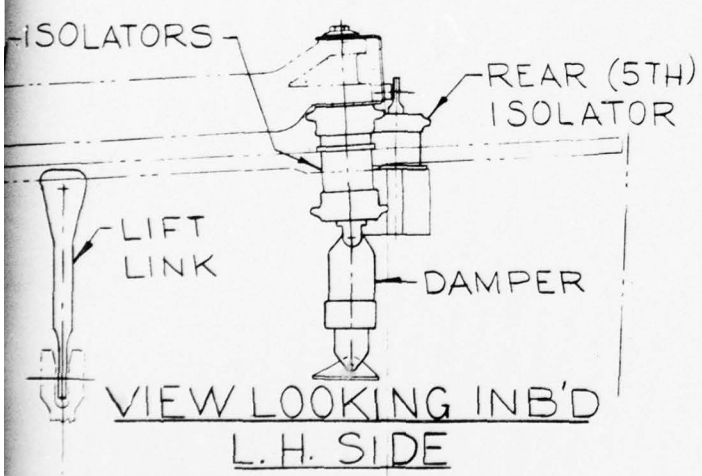
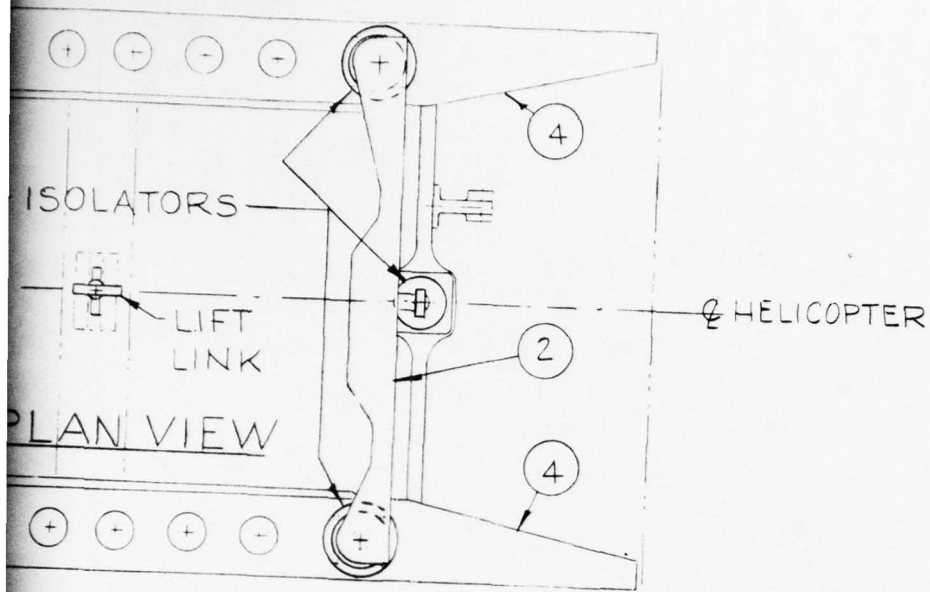

Figure 61. Original UH-1H Isolation System

21



BEST AVAILABLE COPY

BES

3

- ① TRANSMISSION MAIN SUPPORT
- ② SUPPORT-5TH MOUNT
- ③ FITTING - SUPPORT-5TH MOUNT
- ④ SILL STRUCTURE

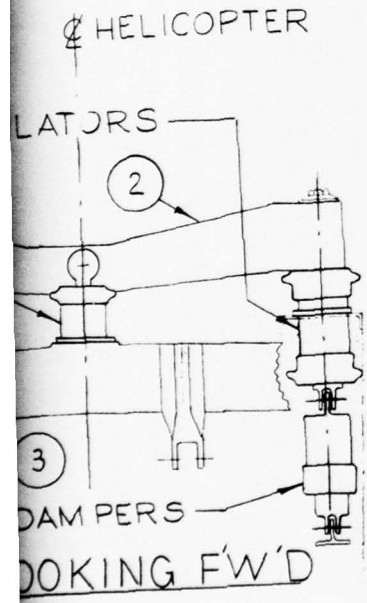

BEST AVAILABLE COPY

1
Preceding Page BLANK - NOT FILMED

BEST AVAILABLE COPY

ALL STRUCTURE SHOWN
OR MODIFIED

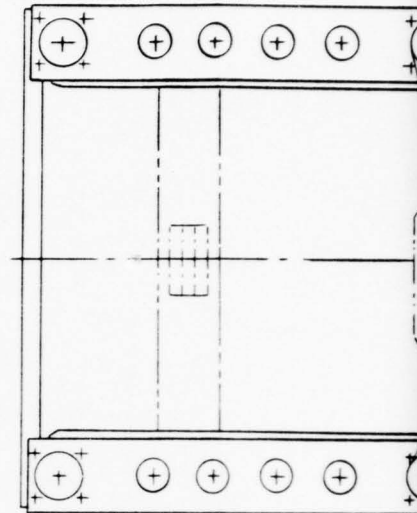

PLAN VIEW

VIEW LOOKING AFT

HELICOPTER

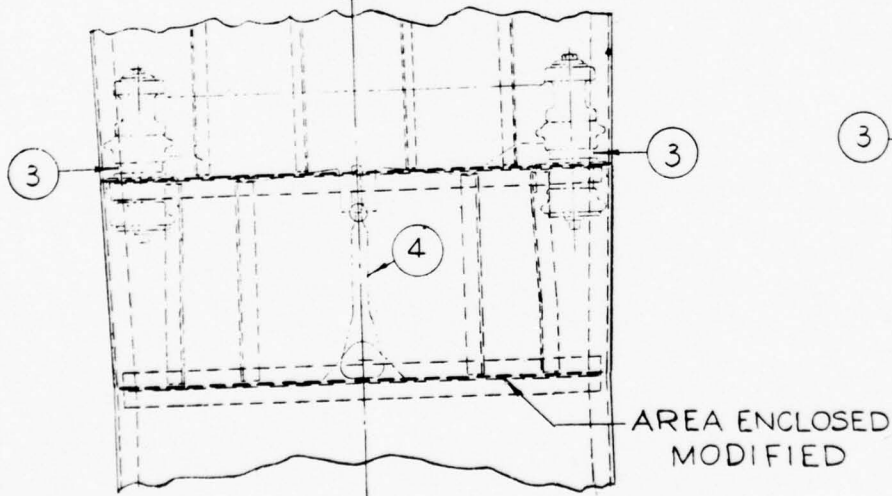

VIEW LOOKING L.H. SIDE

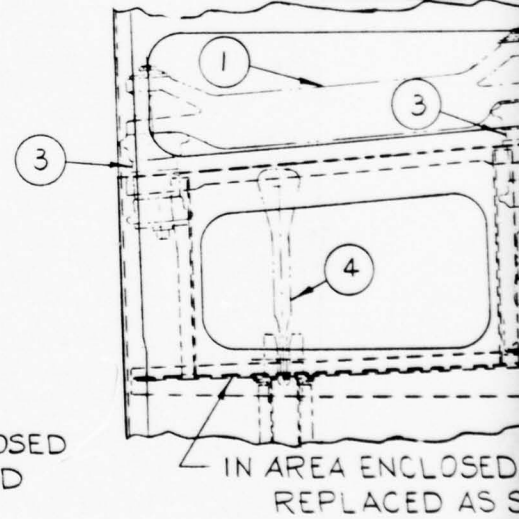
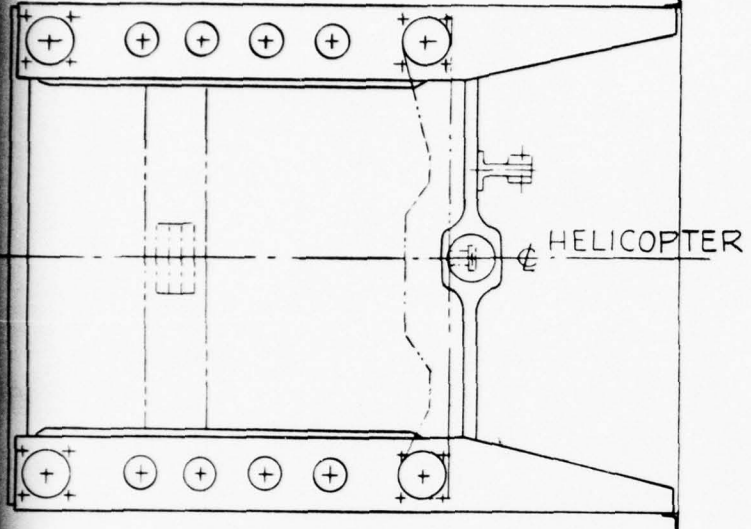

Figure 62. Original UH-1H Structure (Isolator Area)

BES

21

ALL STRUCTURE SHOWN REPLACED
OR MODIFIED



PLAN VIEW

VIEW LOOKING INB'D
L.H. SIDE

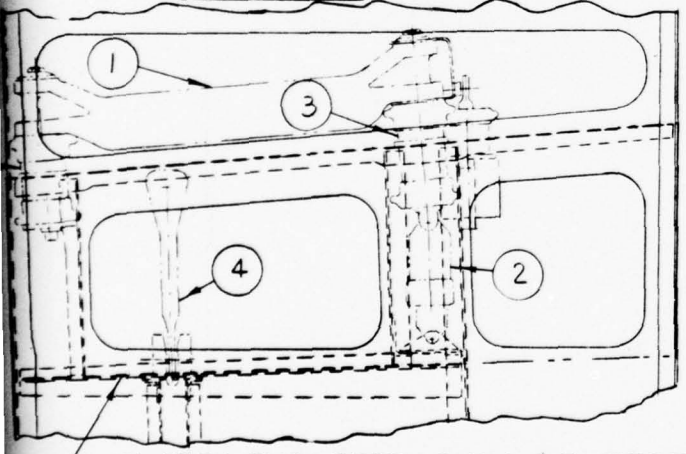

IN AREA ENCLOSED, SKIN & SUPPORTS
REPLACED AS SHOWN ON SH. 2

VIEW LOOKING F'WD

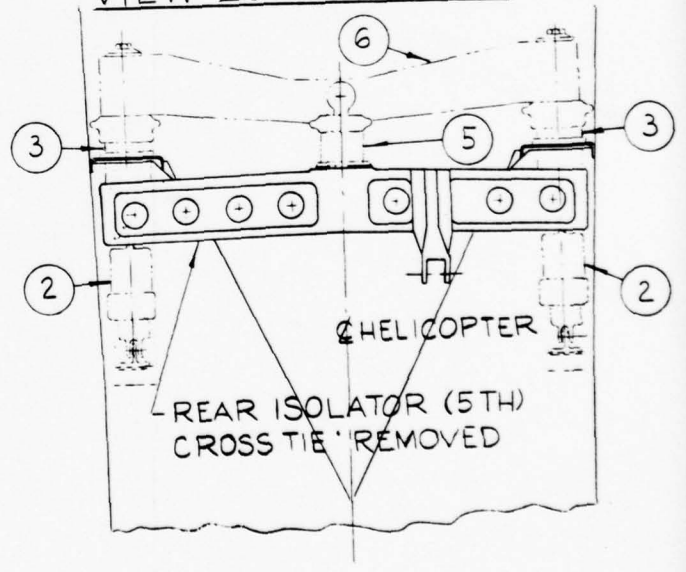

BEST AVAILABLE COPY

KING FWD

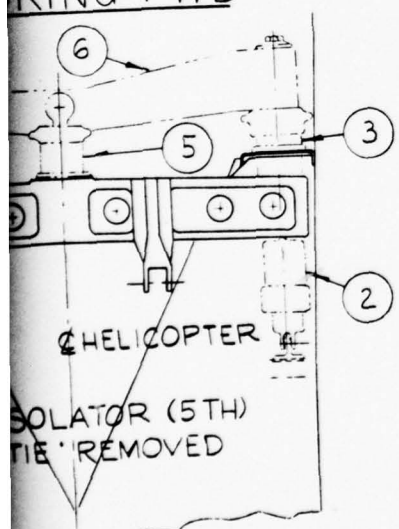

- ① TRANSMISSION MAIN SUPPORT
- ② DAMPER
- ③ ISOLATOR
- ④ LIFT LINK
- ⑤ REAR (5TH) ISOLATOR
- ⑥ SUPPORT-5T MOUNT

BEST AVAILABLE COPY

Preceding Page BLANK - NOT FILMED

* FORE & AFT
CRASH RESTRAINT

BEST AVAILABLE COPY

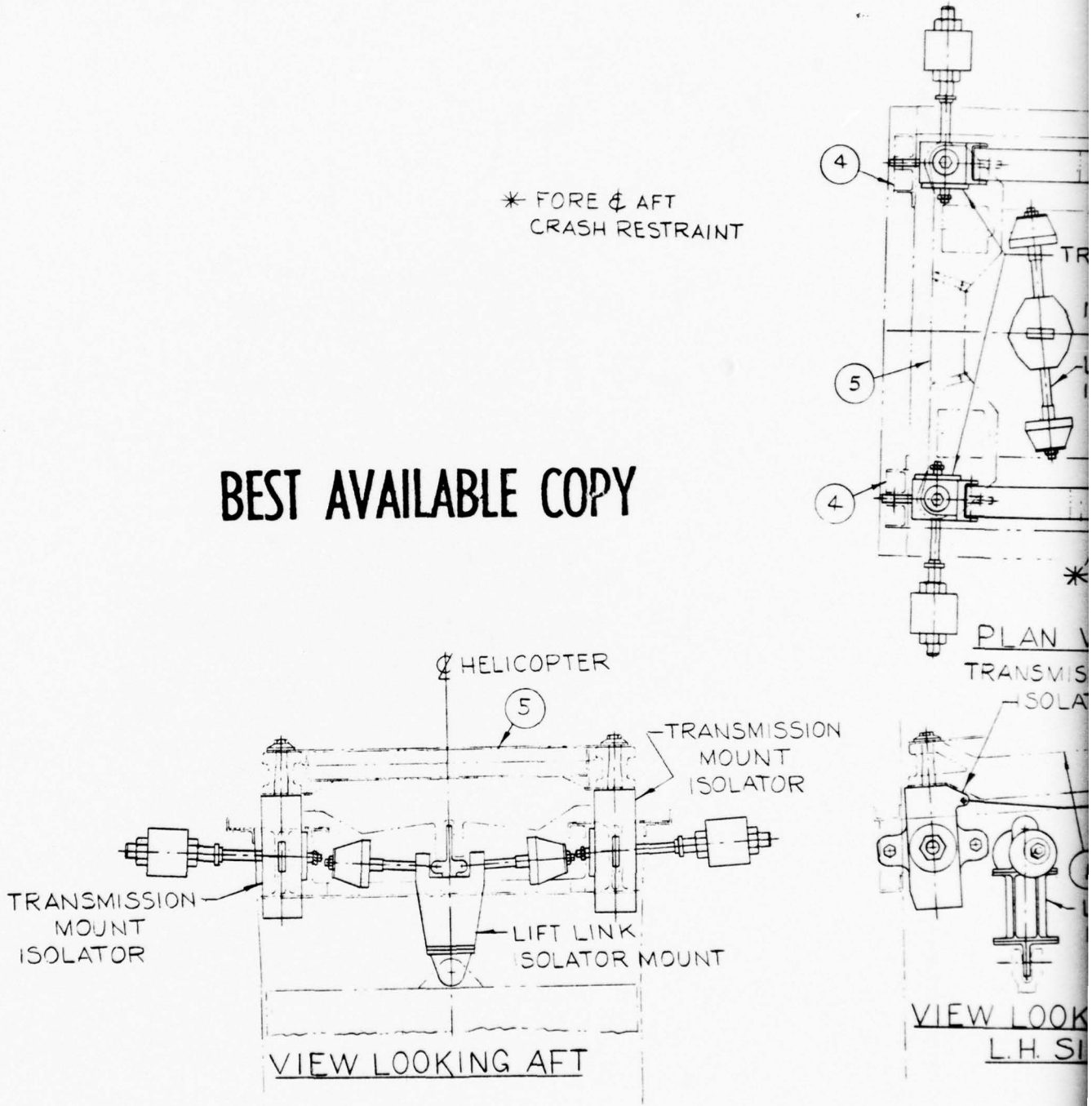
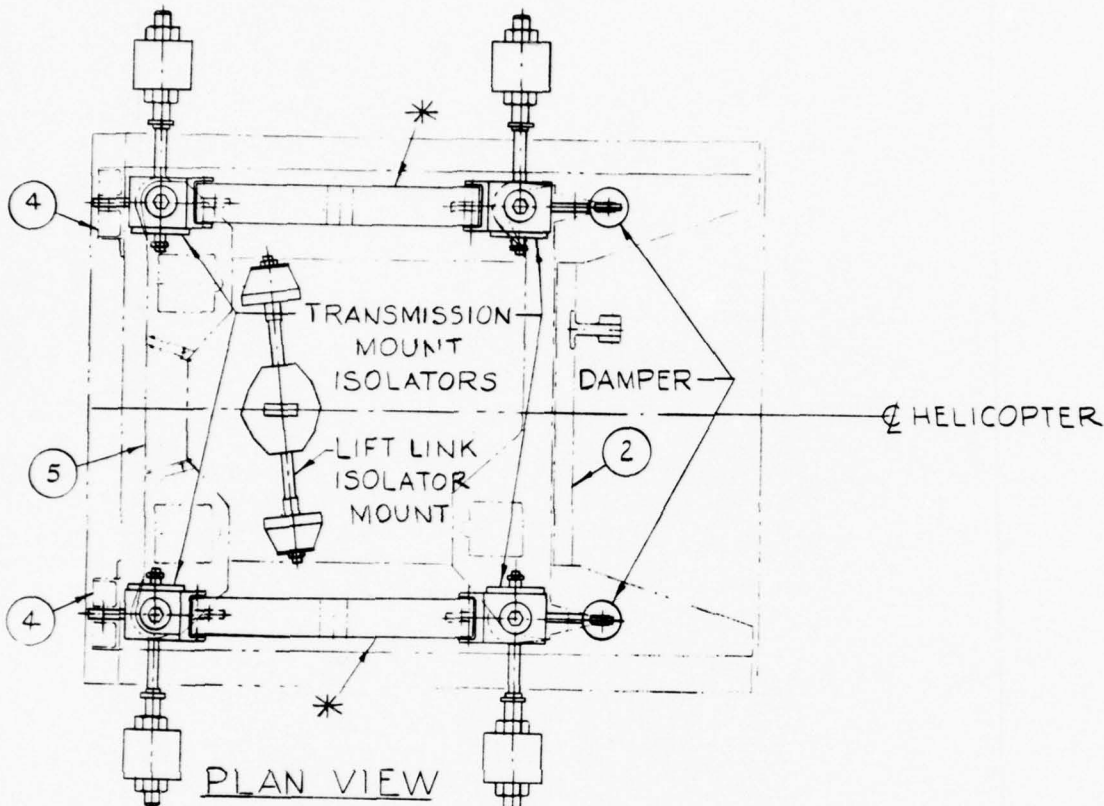

Figure 63. Rotor Isolation System UH-1H Modified

21



PLAN VIEW

TRANSMISSION MOUNT ISOLATORS

DAMPER

LIFT LINK ISOLATOR MOUNT

VIEW LOOKING INB'D L.H. SIDE

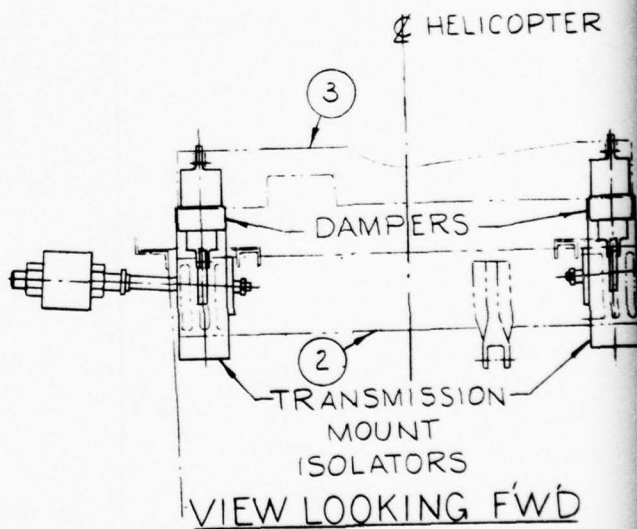

VIEW LOOKING FWD

BEST AVAILABLE COPY

- ① TRANSMISSION MAIN SUPPORT
- ② ISOLATOR SUPPORT, STRUCTURAL LATERAL TIE, STABILIZER CONTROL SUPPORT
- ③ COLLECTIVE SUPPORT BEAM
- ④ ISOLATOR SUPPORT FITTING
- ⑤ NEW LATERAL BEAM

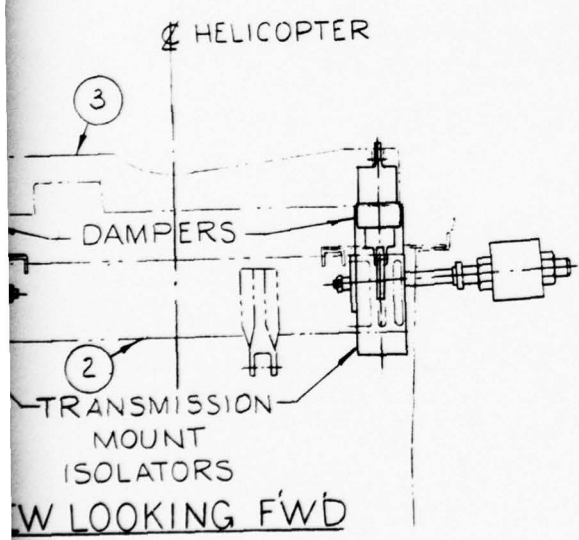

BEST AVAILABLE COPY

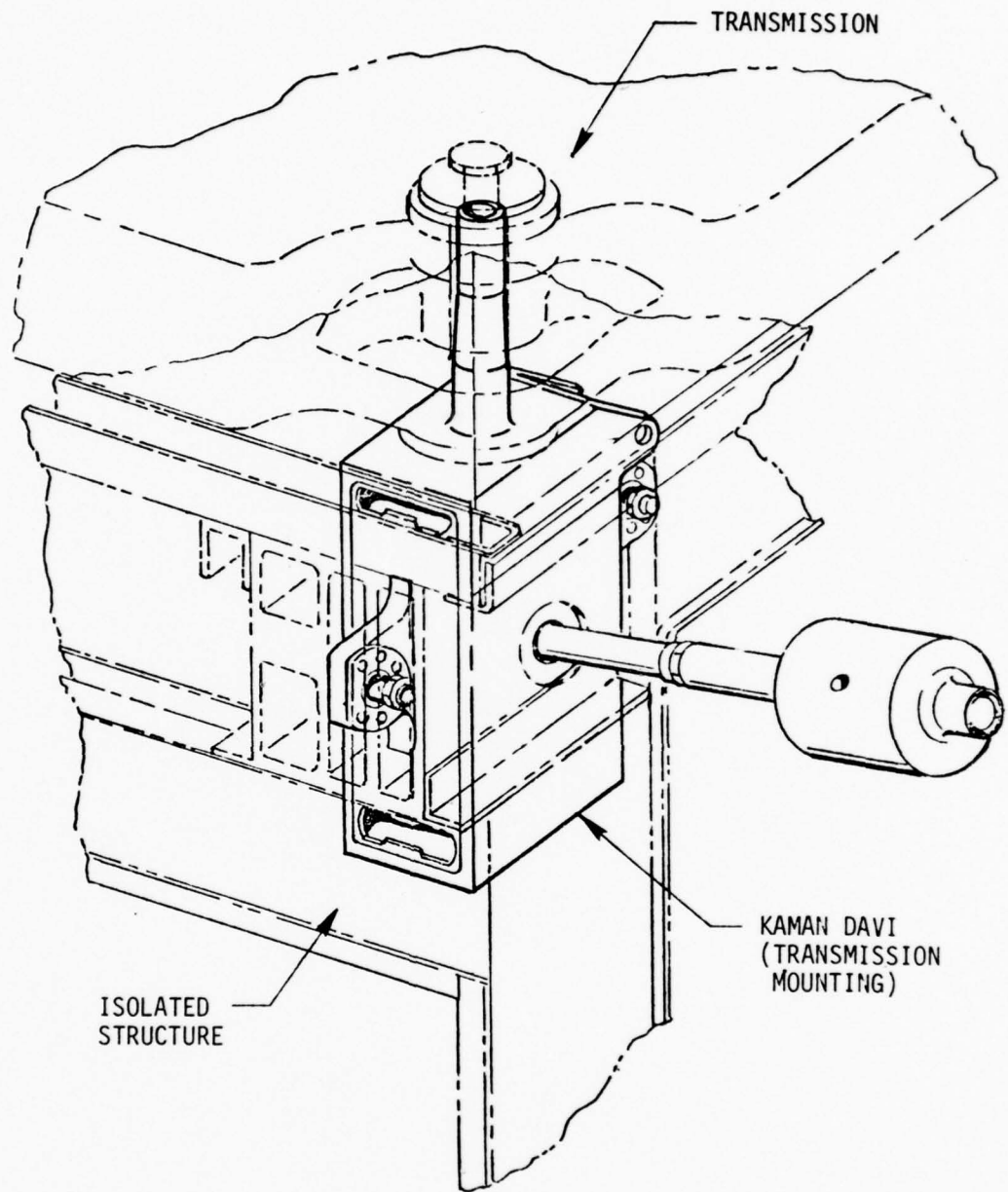

Figure 64. Forward Left DAVI Transmission Mount

NOT.
Preceding Page BLANK - FILMED

BEST AVAILABLE COPY

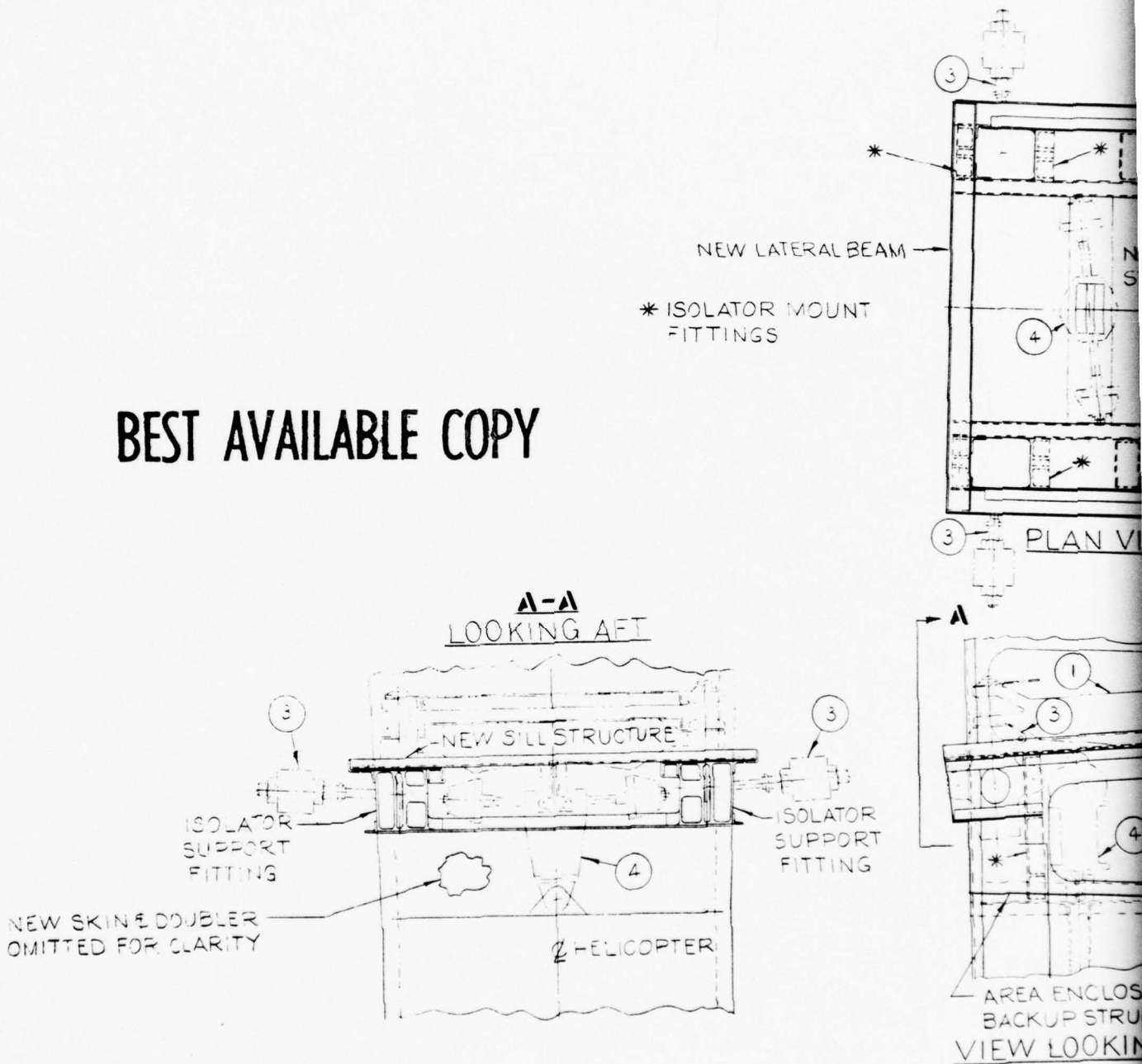
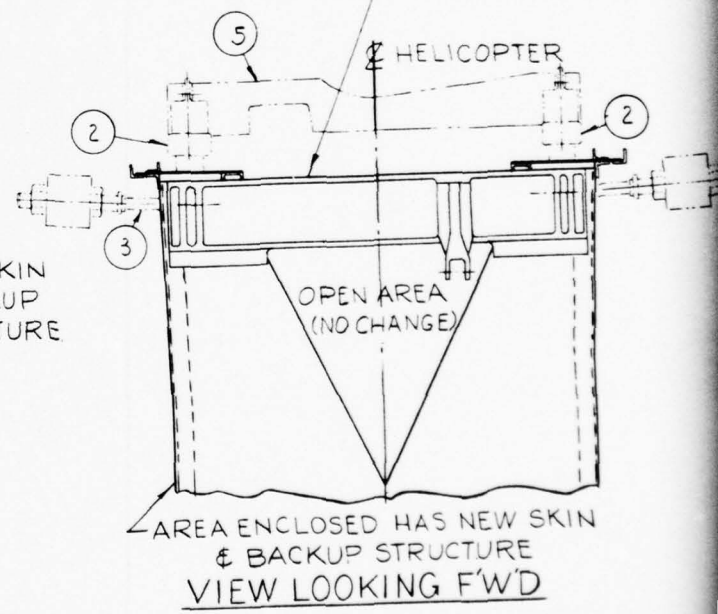
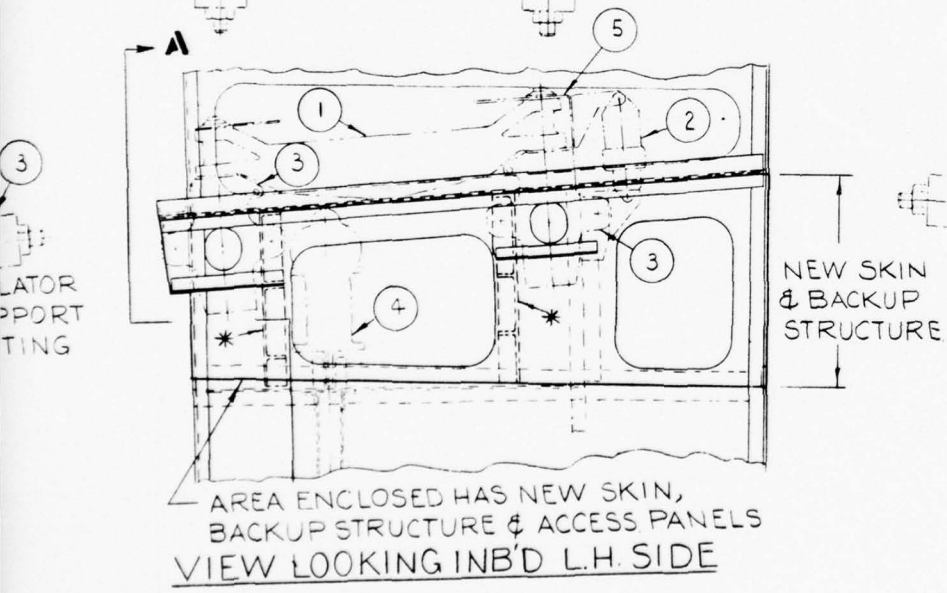
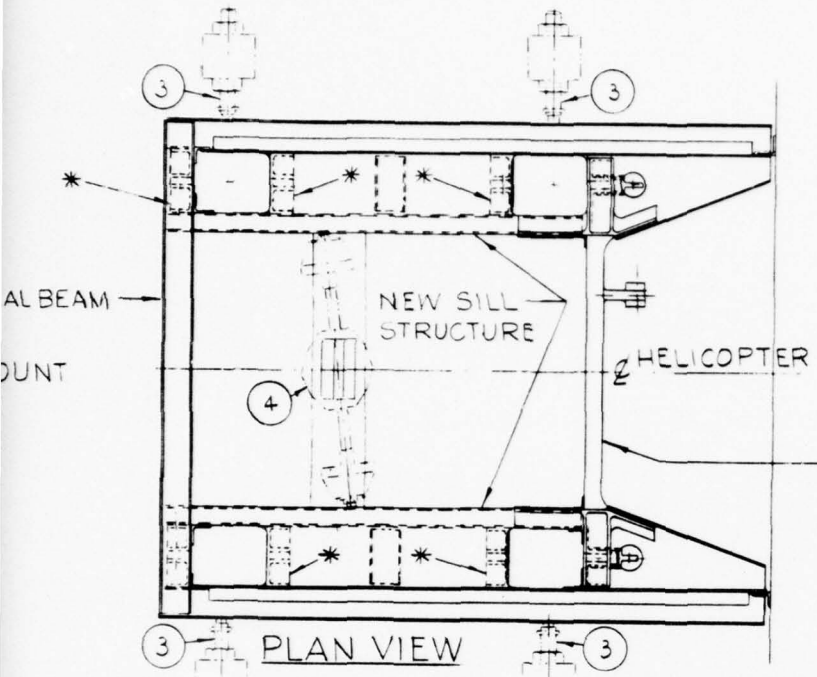

Figure 65. Modified Structure Rotor Isolation System

2



BEST AVAILABLE COPY

3

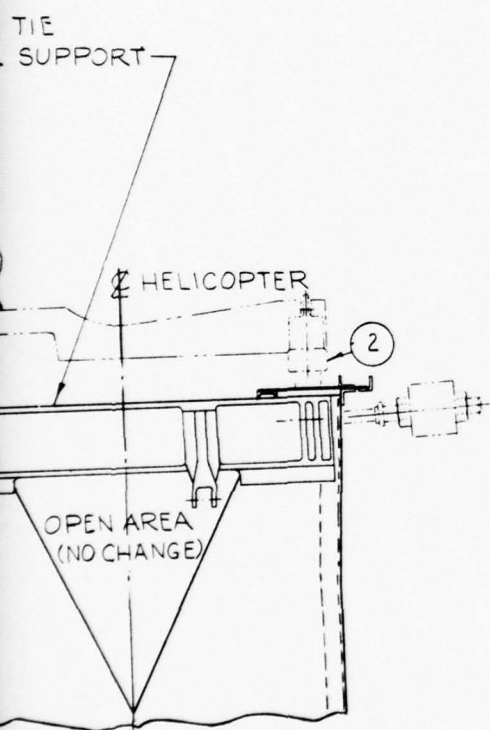

- ① TRANSMISSION MAIN SUPPORT
- ② DAMPER
- ③ TRANSMISSION MOUNT ISOLATOR
- ④ LIFT LINK ISOLATOR MOUNT
- ⑤ COLLECTIVE SUPPORT BEAM

ENCLOSED HAS NEW SKIN
BACKUP STRUCTURE
W LOOKING F'W'D

BEST AVAILABLE COPY

Figure 64 shows an isometric drawing of the DAVI installation. It is seen that the DAVI is retained in the transmission by a tapered machine shaft on the outer (nonisolated) housing and secured by a transmission mounting bolt. This retention is identical to that used in the standard configuration. The DAVI is attached to the fuselage by two machined ears, which are integral parts of the isolated plate and are used to retain the spherical bearings. The spherical bearings are attached to the modified structure by two structure mounting bolts. Spherical bearings are used to keep the isolated plate parallel to the outer (non-isolated) housing to minimize the moments and the torsional restraint of the elastomer.

Figure 65 shows the modified structure for the DAVI isolation system. This figure shows the new isolator mount fittings and the structural modification made on the test vehicle to accept the DAVI isolators. The load paths are similar to the standard system. Reinforcements have been added in some areas, and new bulkhead skins have been installed to allow the DAVI inertia bars to protrude.

Transmission Installation

As shown in Table 16, the DAVI isolation is softer in the vertical direction than the standard system; thus the DAVI system allows a greater static vertical movement of the transmission with respect to the fuselage than the standard vehicle. In order to compensate for this static motion and to insure engine driveshaft alignment, the transmission installation was lowered 0.3 inch relative to the (fuselage) transmission carry-through structure. In addition, the transmission carry-through structure had to be lowered with respect to the underside of the transmission to maintain the original clearance. This lowering of the transmission is illustrated in the schematic of the engine and transmission shown in Figure 66. It is seen from this schematic that, for the unloaded system, the engine driveshaft is misaligned 1.9 degrees with respect to the standard system, and as load is applied, the angular misalignment approaches zero. It is further seen that this .3-inch lowering of the transmission can be controlled by an appropriate combination of spacers. There is presently a .3-inch spacer between the upper face of the transmission main-support base and the transmission mounting bolt. If this .3-inch spacer is located between the lower face of the transmission support base and the upper face of the DAVI outer housing, the transmission location is identical to that of the standard system. Thus, by a proper combination of spacers, any desired location of the transmission from 0 (standard location) to .3-inch displacement can be obtained.

Description, Transmission-Mount DAVI

The three-view schematic of the DAVI transmission mount is shown in Figure 67. This mount is a two-dimensional DAVI and is oriented to give DAVI isolation in the vertical and longitudinal directions and

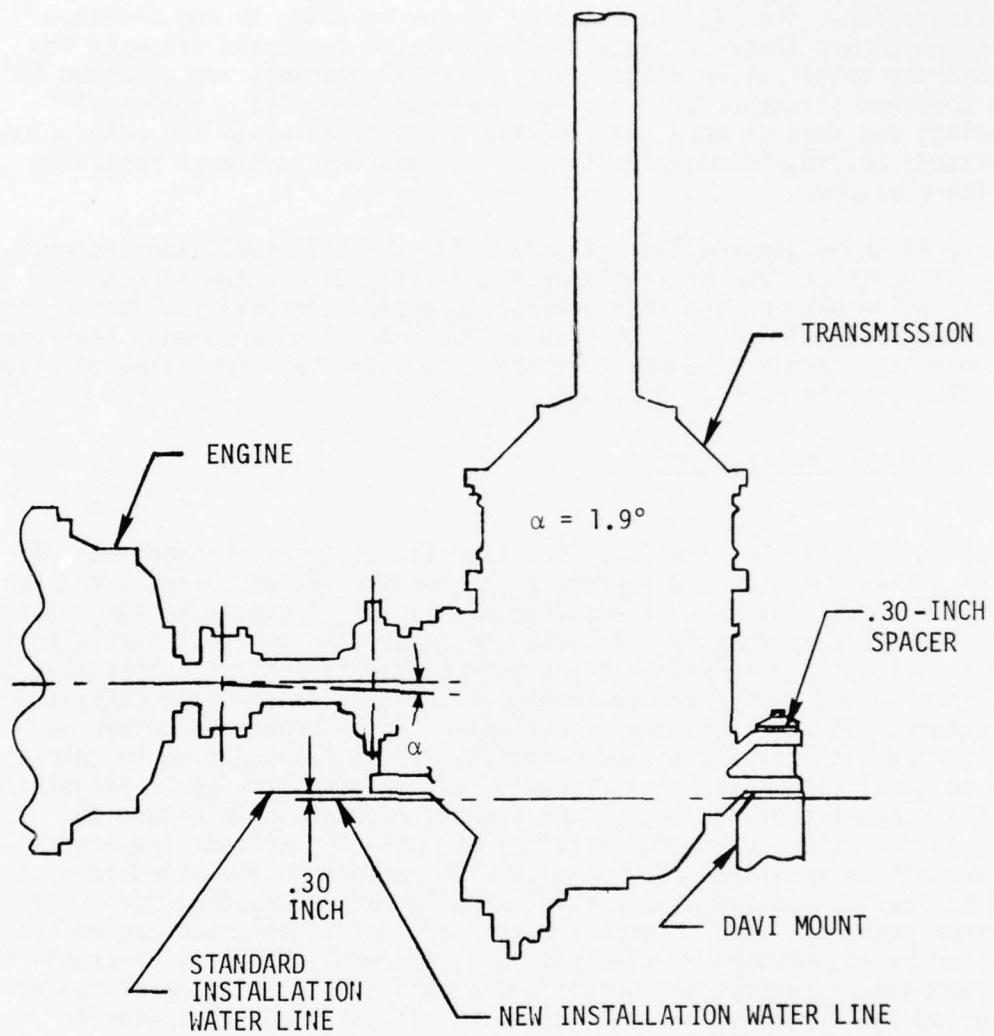

Figure 66. Schematic of Engine-Transmission

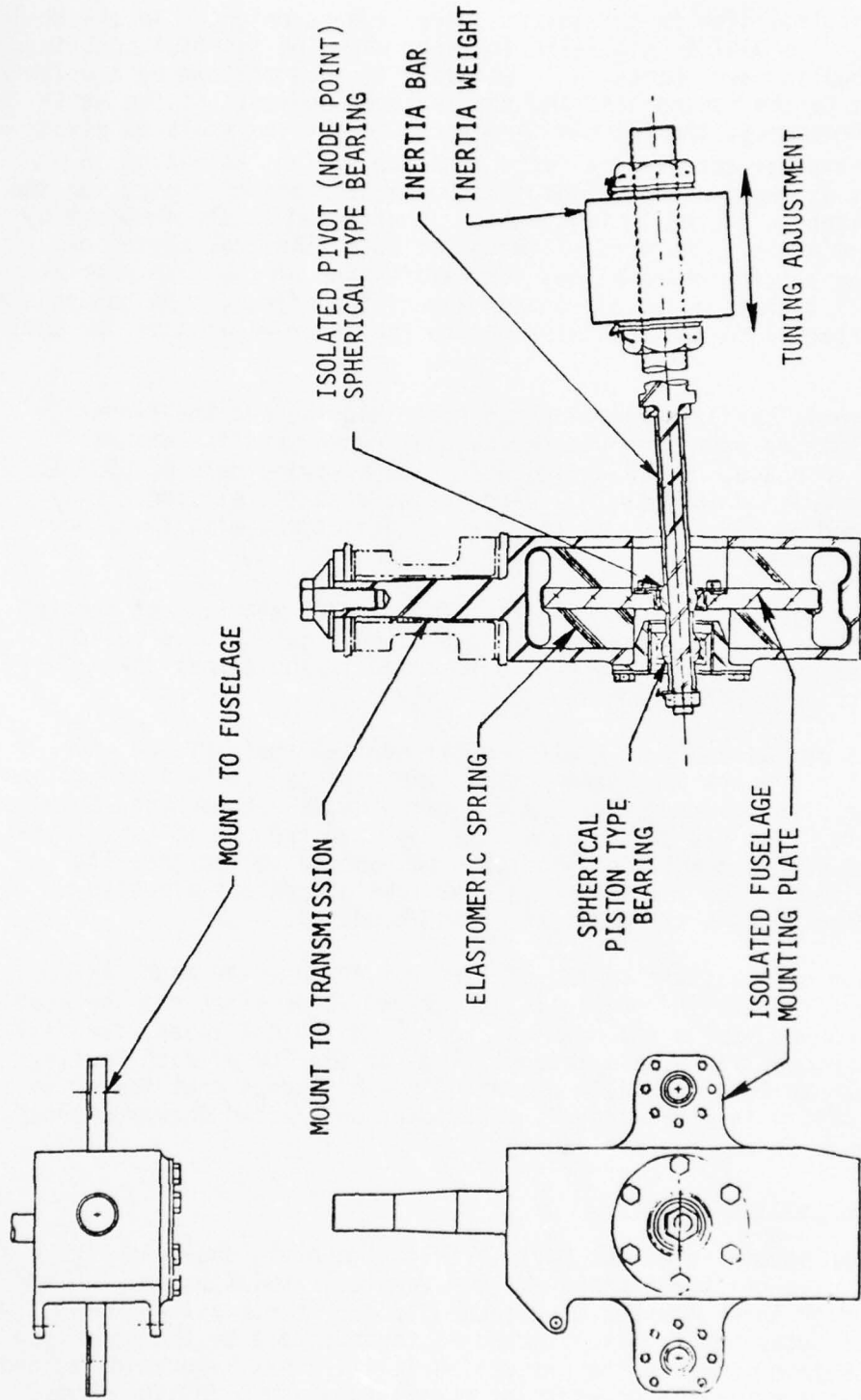

Figure 67. DAVI Transmission Mount

conventional isolation in the lateral direction as oriented in the UH-1H helicopter. The DAVI is a passive isolator based on inertial coupling. Inertial coupling and, hence, antiresonance is accomplished by a weighted bar pivoted to the nonisolated and the isolated bodies. At the antiresonance frequency, the inertia force produced at the isolated pivot of the inertia bar cancels the force from the spring, resulting in a nodal point at the isolated pivot. A spherical bearing is used for the isolated pivot in the UH-1H DAVI, which is attached to the fuselage by the isolated plate. The nonisolated pivot is a spherical piston or sliding type bearing which allows for compression of the elastomer for conventional isolation and eliminates any cosine effect. The nonisolated pivot is attached to the transmission via the outer housing of the DAVI mount.

The elastomeric spring separating the outer housing and the (inner) isolated plate is made from uncured natural rubber and is integrally vulcanized in place. It is designed to give a spring rate of 6500 lb/in. in the vertical and longitudinal directions, with the elastomer acting in shear, and 53,000 lb/in. in the lateral direction, with the rubber acting in compression.

The outer housing is an integral machining of 4340 steel, heat treated to 180,000 psi. The upper end of each housing consists of a solid tapered shaft which fits into and is fastened to the transmission lugs in a manner identical to the standard system.

The inertia bar assembly is a stepped cylindrical shaft fitted with three tubular spacers that sandwich the inner races of the isolated and nonisolated pivot bearings between a locking nut and a machined shoulder on the shaft. The basic inertia bar is machined from PH 15-5 stainless steel, hardened to condition H1150 and shot-peened to increase its endurance limit. The inertia weight and tubular spacers are also machined from PH 15-5 stainless steel and hardened.

In the event of a failure of the elastomeric spring, the mount assembly is inherently fail-safe for vertical and lateral loads since the isolated plate is trapped inside the housing. For longitudinal loads, the fail-safe feature consists of two integral lugs at the top of each housing which attach to longitudinally oriented "crash" straps that fasten to the upper sill - thus reacting forward loads on the two forward mounts and aft loads on the two aft mounts.

Description, Lift-Link DAVI

A three-view schematic of the DAVI lift link mount is shown in Figure 68. This mount is a unidirectional DAVI for vertical isolation only. The nonisolated or inner housing is attached to the transmission, while the isolated or outer housing is attached to the fuselage by the same type of spherical bearing used in the present UH-1 lift link. Two unidirectional inertia bars are used to prevent any moment unbalance. A hinge-type

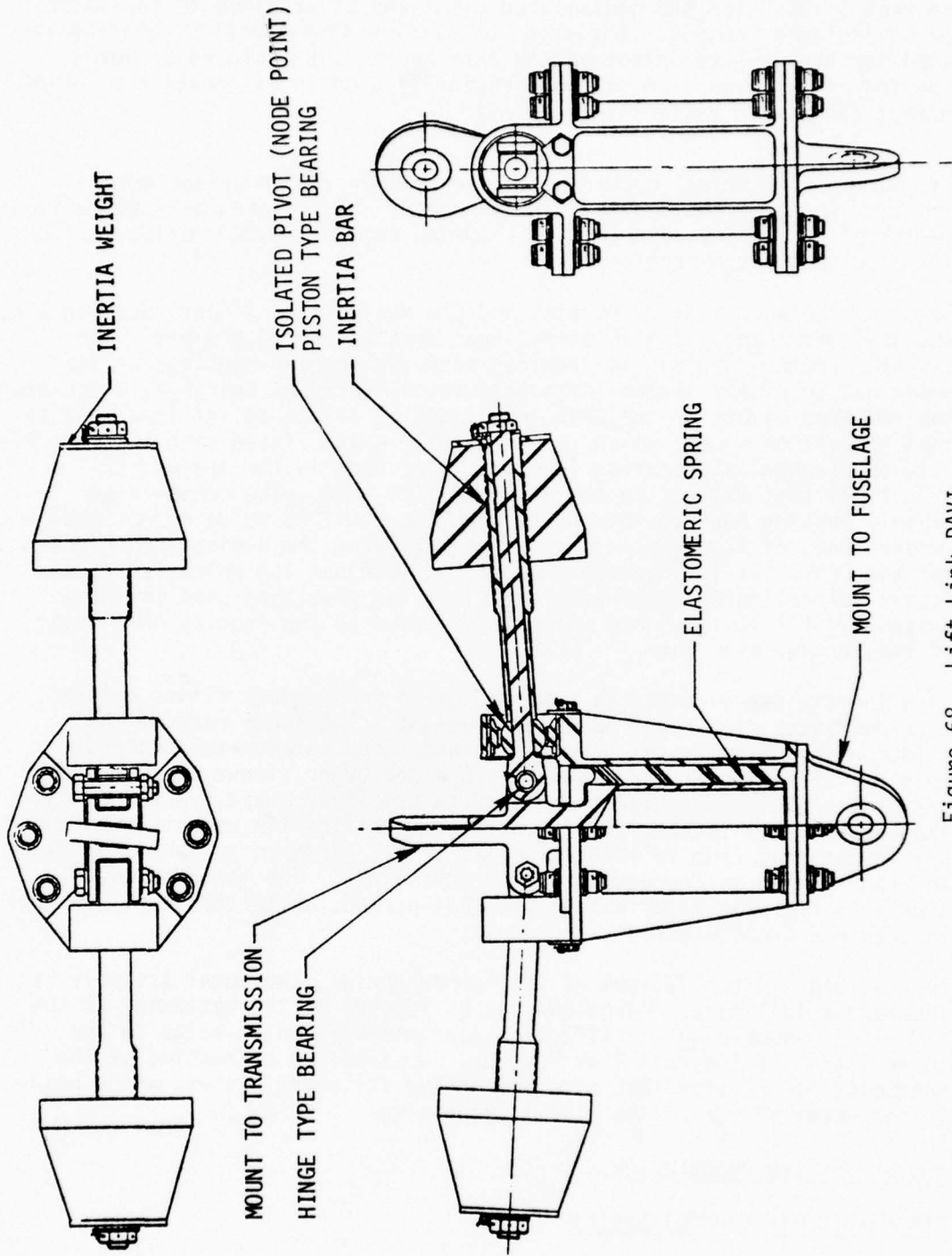

Figure 68. Lift Link DAVI

bearing is used for the nonisolated pivot and is attached to the inner or nonisolated housing. A piston- or sliding-type spherical bearing is used for the isolated pivot and is attached to the isolated or outer housing of the mount. A sliding bearing is used to eliminate the cosine effect for static deflection.

The hollow cylindrical rubber spring separating the inner and outer housings is made from uncured natural rubber and is integrally vulcanized in place. It is designed to give a spring rate of 10,000 lb/in. in the axial or vertical direction.

Both the isolated (outer) housing and the nonisolated (inner) housing are integral machinings of 4340 steel, heat treated to 180,000 psi. The isolated (outer) housing is provided with two bearing housings at its upper end to accept piston- or sliding-type spherical bearings, which are the isolated pivots of the DAVI. An integral flange at its lower end is used to bolt on a cap, which is essentially a lug fitted with a self-aligning (spherical) bearing (the same type used in the present UH-1 lift link) that fastens to the airframe lift beam. The nonisolated (inner) housing has two integrally machined clevises which accept the inboard ends of the inertia bars, thus providing the nonisolated pivots for the DAVI. At its uppermost end is an integral lug which is fitted with a self-aligning (spherical) bearing (the same type used in the present UH-1 lift link) and which is fastened to the lugs at the bottom of the transmission case.

Each inertia bar assembly is composed of an inner shaft fitted with a threaded outer sleeve and an inertia weight. The inner race of the sliding-type of spherical bearing is sandwiched between the inboard shoulder of the inner shaft and the threaded outer sleeve whose outboard end is loaded by a locking nut fitted to the inner shaft. A thread on the outer sleeve is provided for attaching the inertia weight. The inner bar is machined from PH 15-5 stainless steel, hardened to condition H1150 and shot-peened to increase its endurance limit. The threaded outer sleeve is the same material but not shot-peened, while the inertia weight is machined from tungsten.

In the event of the failure of the rubber spring, the mount assembly is inherently fail-safe. Down-load can be reacted by the bottoming of the lift link assembly on the lift link cap assembly, which bolts to the lower flange of the lift link housing. Up-load can be reacted by the bottoming of the lift link assembly on the fail-safe plates, which bolt to the upper flange of the lift link housing.

CONTROL SYSTEM DESCRIPTION

Standard UH-1H Control System

In the standard vehicle, the collective and cyclic boost actuators bypass the isolation system and are mounted directly to the fixed airframe

structure, thus transmitting vibratory control loads directly to the fuselage. The arrangement of the standard collective and cyclic boost control system is shown schematically in Figure 69.

DAVI-Modified Control System

In order to minimize the vibration in the fuselage due to the vibratory control forces, the collective and cyclic boost actuators have been located on the nonisolated transmission; thus the isolation of vibratory control loads as well as the vibratory rotor forces is achieved by DAVI isolation. This is shown schematically in Figure 70. If no other changes are made to the control system other than the relocation of the boost actuators to the transmission, the vertical motion of the transmission relative to the fuselage would cause corresponding motion in the control system, resulting in possible undesirable control inputs to the rotor as well as feedback to the stick. As seen in Figure 70, a parallel compensating idler linkage and compensation rods have been designed to essentially eliminate any control input due to relative motion of the transmission and fuselage, thus minimizing any vibratory control input or feedback to the stick.

The two cyclic boost actuators have been relocated to a welded steel beam that straddles the forward transmission lugs, while the collective boost actuator has been relocated to a welded steel beam that straddles the aft transmission lugs.

The new compensating linkage in the cyclic control system consists of pairs of compensating rods, idlers and idler support fittings. The upper end of each compensating rod is anchored to the underside of the welded steel cyclic support beam, which straddles the forward pair of transmission lugs. The lower end of each cyclic compensating rod, anchored to and acting in conjunction with the compensating idler, forms the new support for the original cyclic bellcrank. Each cyclic compensating idler support fitting is attached to the forward face of a new sheet-metal beam in the fuselage tub at W.L. 19.5 and F.S. 141.4, which straddles and attaches to the left and right main panel beams at B.L. 14.

The new compensating linkage in the collective control system consists of a single compensating rod, an idler and an idler support fitting. The upper end of the compensating rod is anchored to a steel weldment which attaches to the underside of the transmission by means of the oil sump mounting bolts. The lower end of the compensating rod, anchored to and acting in conjunction with the compensating idler, forms the new support for the original collective bellcrank. The collective compensating idler support fitting is attached to the aft face of the same new sheet-metal beam in the fuselage tub as the cyclic compensating idler support fitting.

A new compensating linkage has also been added for the droop compensator jack shaft, replacing the original forward support. This compensating linkage consists of a single compensating rod, an idler and an idler

BEST AVAILABLE COPY

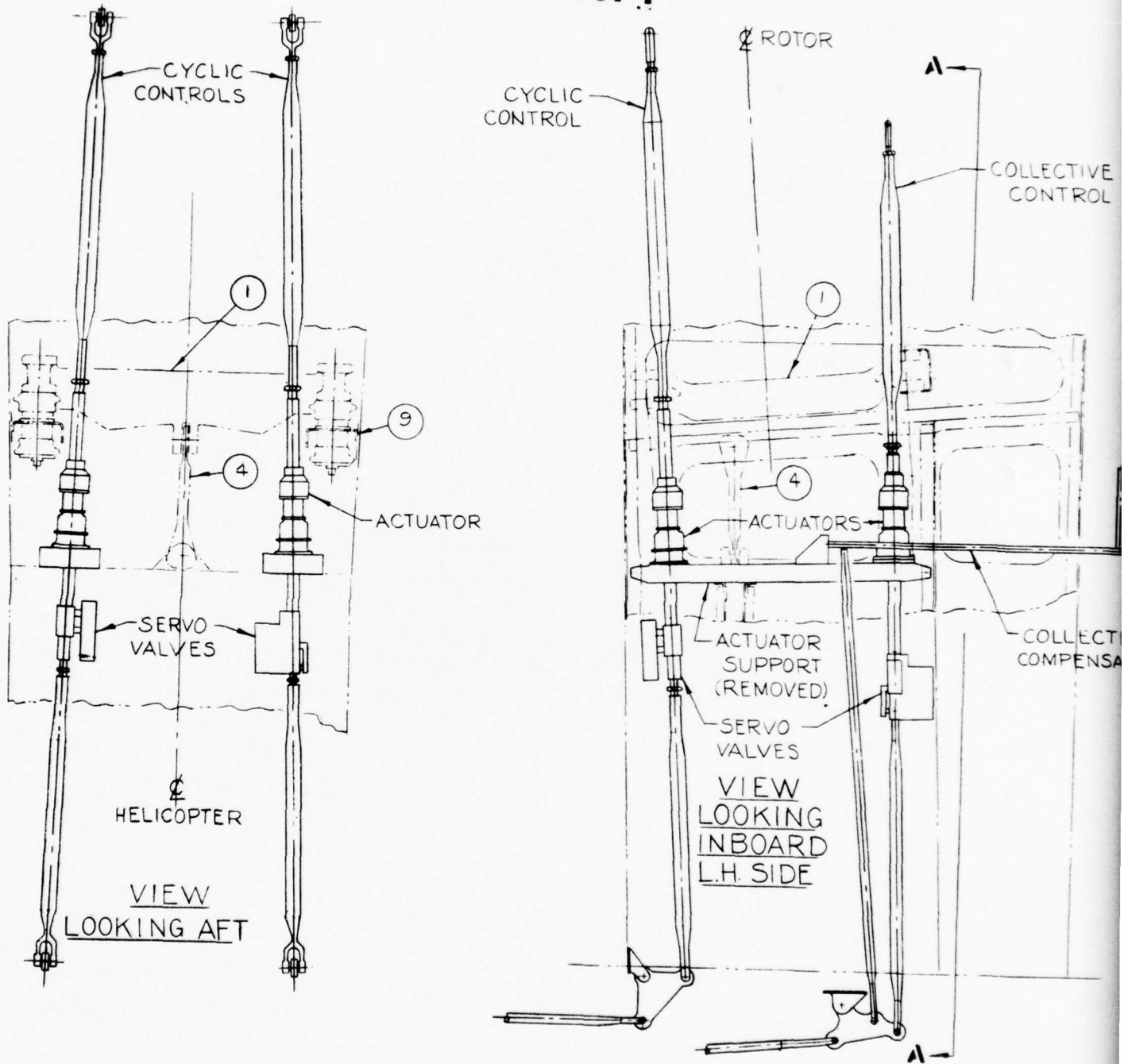
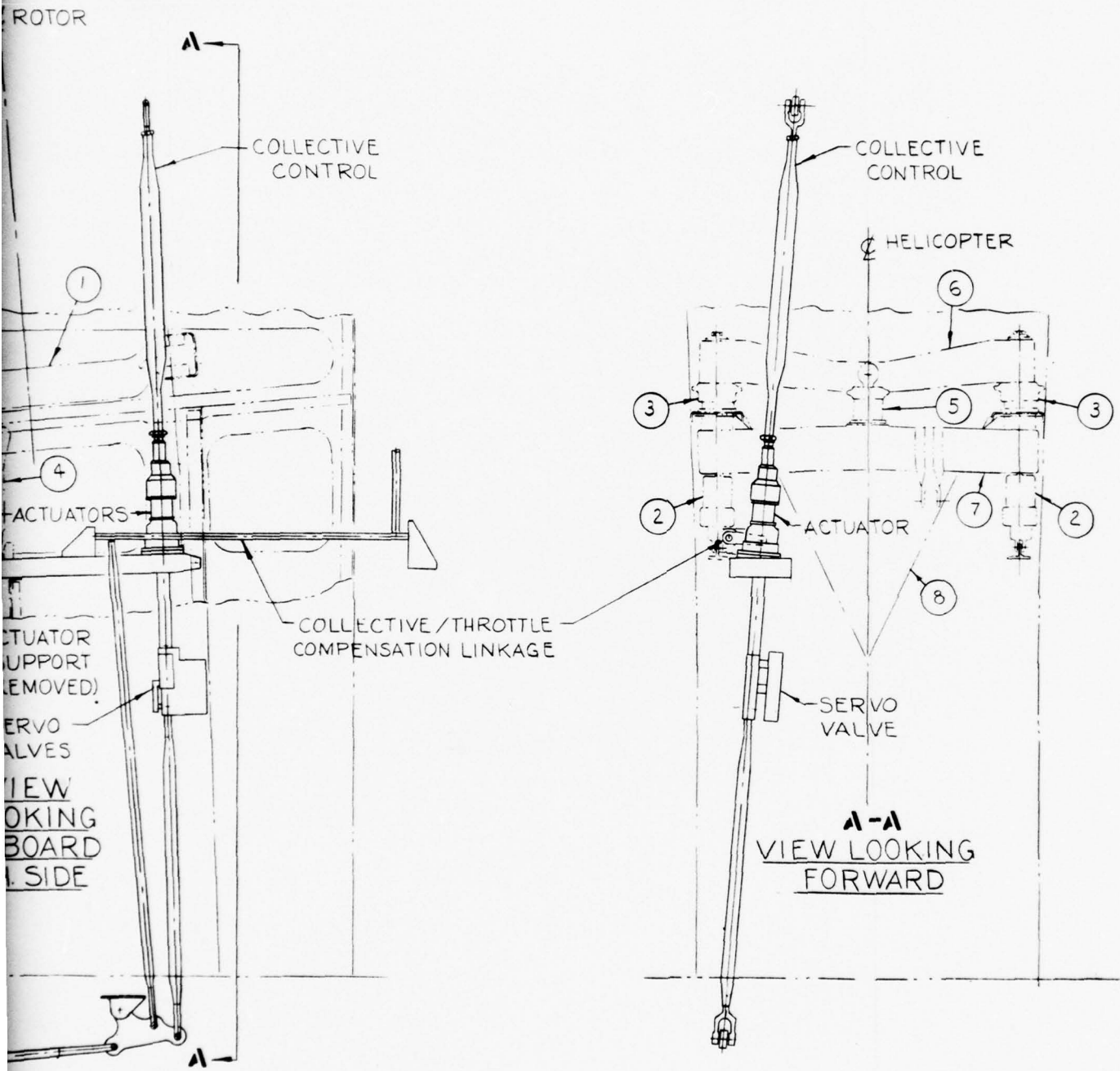

Figure 69. Original UH-1H Control System

2



- ① TRAN
- ② DAMP
- ③ ISOLA
- ④ LIFT
- ⑤ REAR
- ⑥ SUPP
- ⑦ FITTI
- ⑧ AFT C
- ⑨ SILL

BEST AVAILABLE COPY

3

CTIVE
ROL

ICOPTER

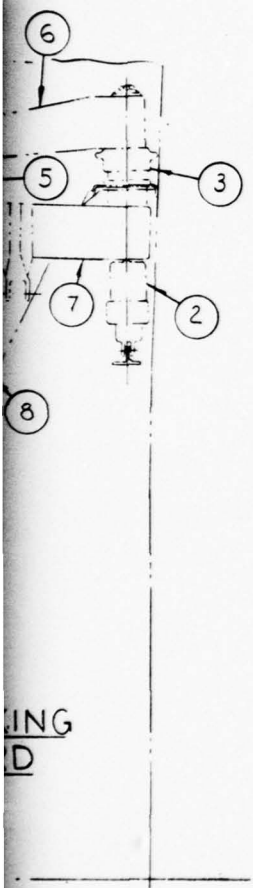

- ① TRANSMISSION MAIN SUPPORT
- ② DAMPER
- ③ ISOLATOR
- ④ LIFT LINK
- ⑤ REAR (5TH) ISOLATOR
- ⑥ SUPPORT-5TH MOUNT
- ⑦ FITTING - SUPPORT-5TH MOUNT
- ⑧ AFT CANTED BULKHEAD
- ⑨ SILL STRUCTURE

ING
D

BEST AVAILABLE COPY

BEST AVAILABLE COPY

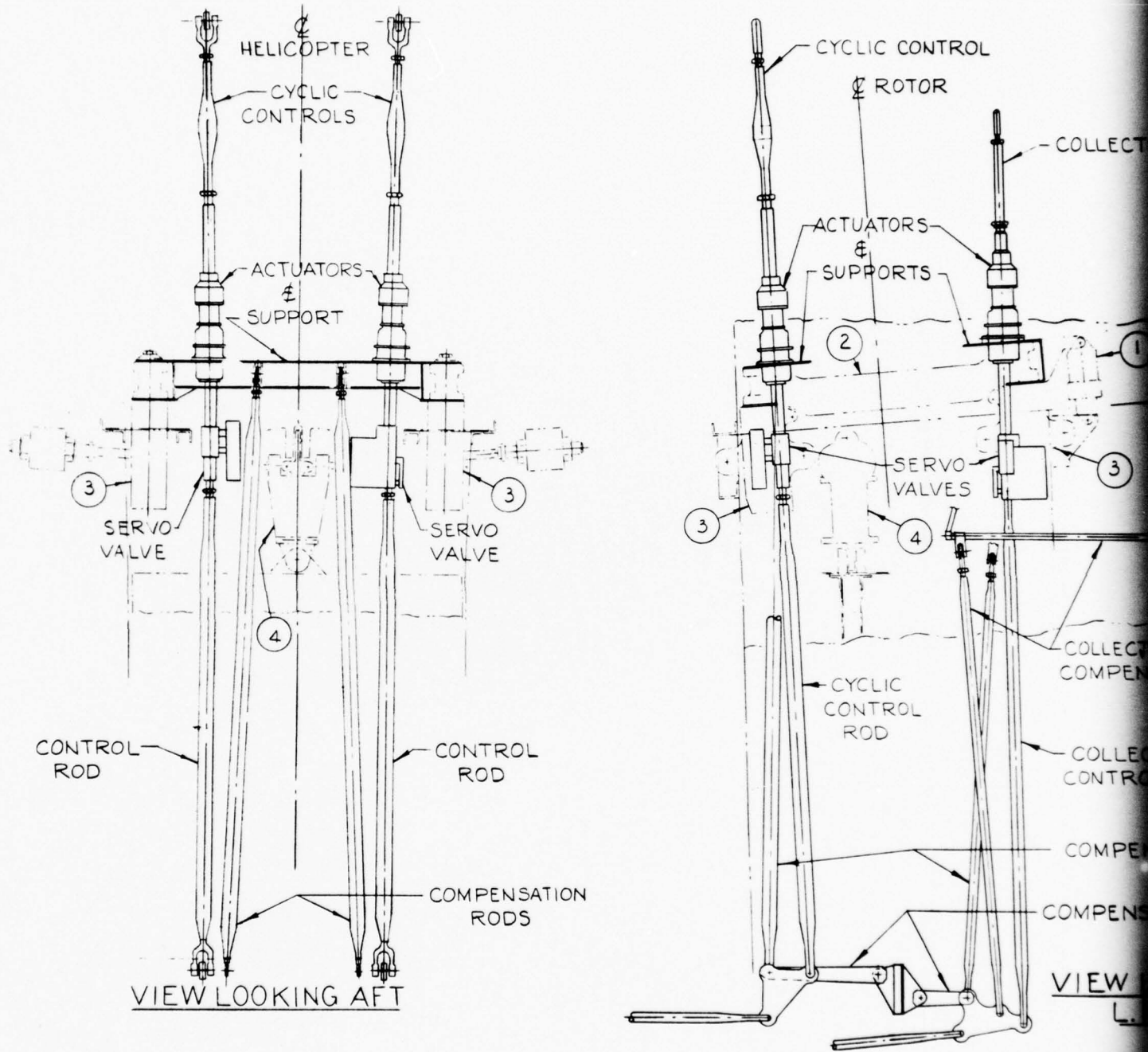
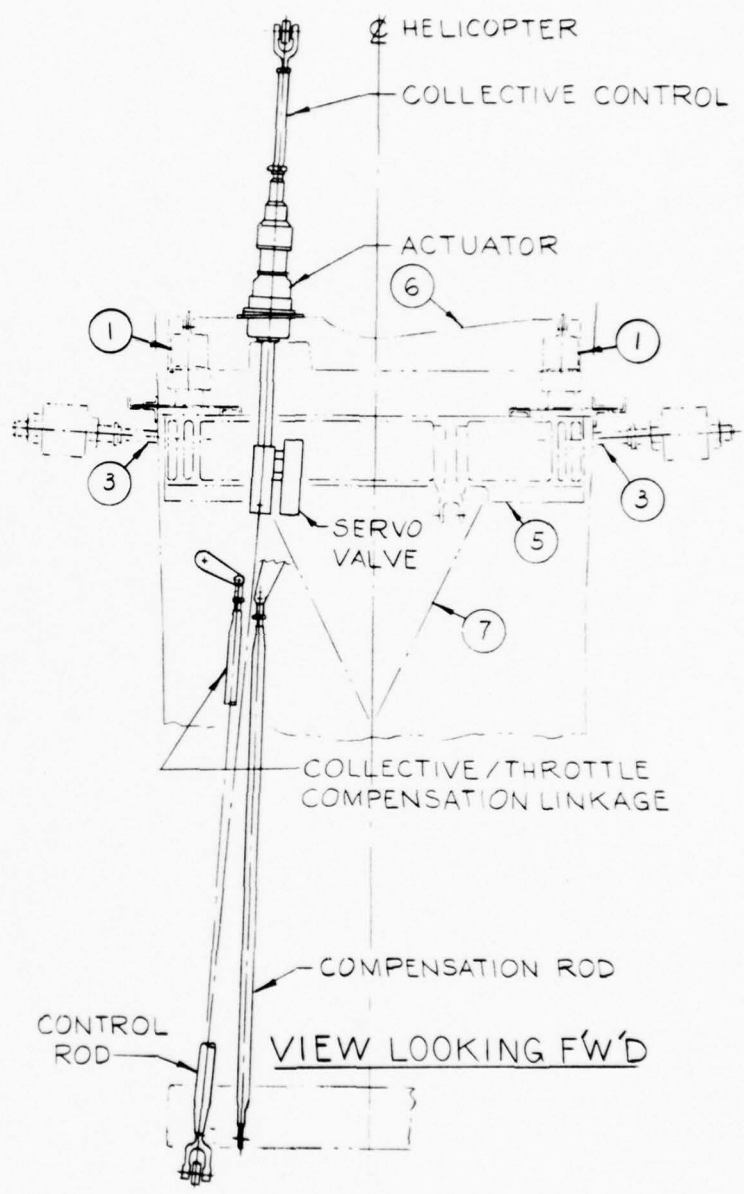
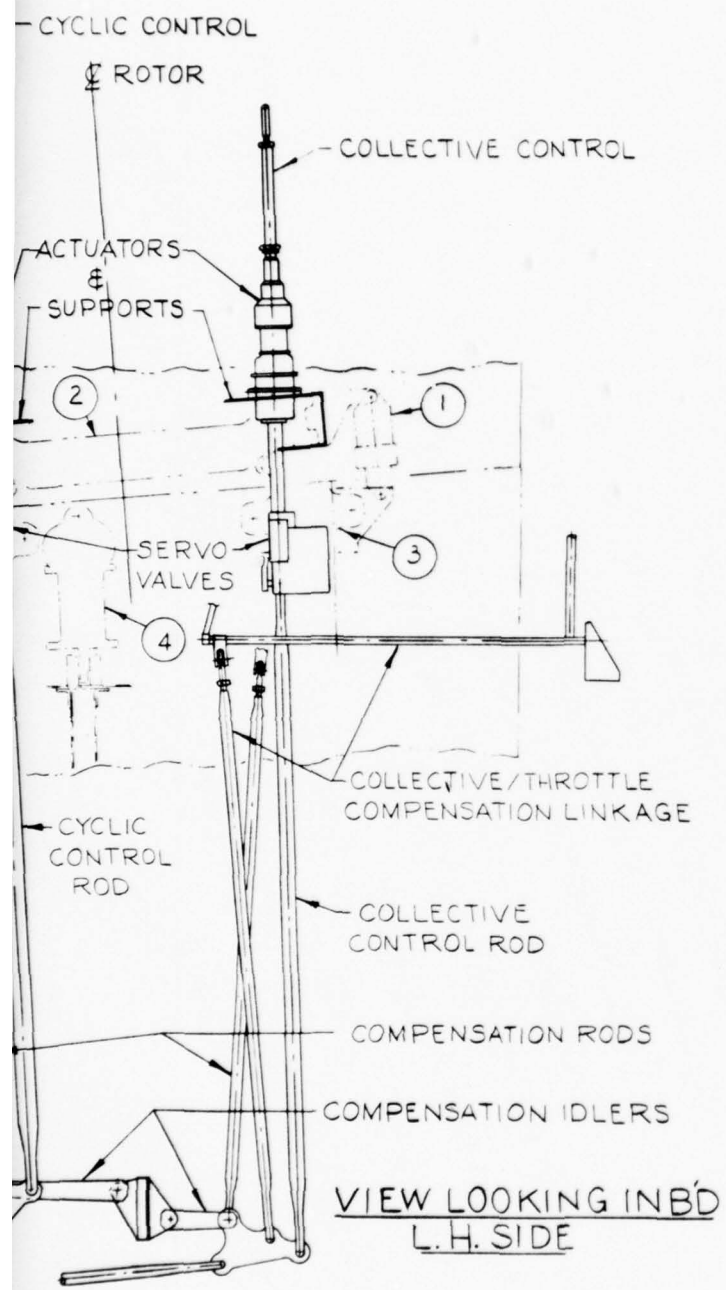

Figure 70. UH-1H Isolated Controls Rotor Isolation Program

2



BEST AVAILABLE COPY

3

HELICOPTER
COLLECTIVE CONTROL

ACTUATOR

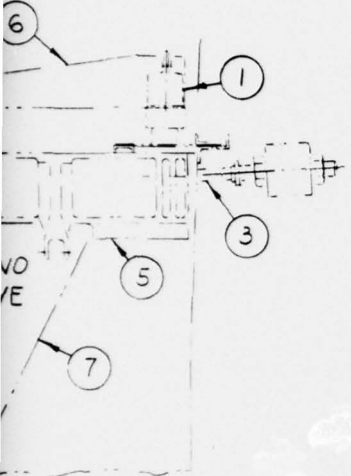

- ① DAMPER
- ② TRANSMISSION MAIN SUPPORT
- ③ TRANSMISSION MOUNT ISOLATOR
- ④ LIFT LINK ISOLATOR MOUNT
- ⑤ ISOLATOR SUPPORT, STRUCTURAL LATERAL TIE, STABILIZER CONTROL SUPPORT
- ⑥ COLLECTIVE SUPPORT BEAM
- ⑦ AFT CANTED BULKHEAD

CTIVE / THROTTLE
NSATION LINKAGE

PENSATION ROD

LOOKING FWD

BEST AVAILABLE COPY

support fitting. The idler and the idler support fitting are those of the collective compensating linkage, while the compensating rod is the same rod used in the original collective throttle linkage. The upper end of the compensating rod picks up the same crank on the jack-shaft as did the original control rod. The forward end of the jack-shaft is supported by an arm that rotates about a lateral axis, thus compensating for the longitudinal motion of the transmission. This arm is an integral part of the steel weldment under the transmission that is used for anchoring the upper end of the collective compensating rod.

The location of the cyclic and collective boost actuators required the following changes to the original control rods:

Collective Control Rod - This connects the collective servo valve to the bellcrank at W.L. 18.5. A length increase of 17.4 in. was obtained by lengthening the basic swaged-aluminum tube. The basic tubing diameter was increased from 7/8 to 1-1/8 in. O.D., while the wall thickness was unchanged.

Cyclic Control Rods - These connect the cyclic servo valves to the bellcranks at W.L. 19.5. A length increase of 16.0 in. was obtained by lengthening the basic swaged-aluminum tube. The basic tubing diameter was increased from 7/8 to 1-1/8 in. O.D., while wall thickness was unchanged.

Collective Servo Rod - This connects the upper end of the collective boost actuator to the collective lever assembly. A length decrease was obtained by shortening the basic swaged-aluminum tube.

Cyclic Servo Rods - These connect the upper ends of the cyclic boost actuators to the inner ring assembly. A length decrease was obtained by shortening the basic swaged-aluminum tube.

ANALYSIS

STRUCTURAL ANALYSIS

The same critical flight, landing and crash conditions used for the design of the UH-1H helicopter were used for the modified UH-1H, and in addition, a high gross weight steady-state 45-degree banked turn condition was included. Loads applied to the four transmission DAVIs and the lift link DAVI were then calculated, taking into account the new geometry, mounting arrangement, spring rates, motions, etc. The static load distribution throughout the carry-through structure was then determined, and this structure, together with the transmission mount and lift-link DAVIs, was stress analyzed. In addition, a fatigue analysis for the DAVI mounts was conducted for two critical vibratory (flight) conditions.

The same critical jam load conditions used for the UH-1H helicopter were used for the modified control system, and in addition, loads in the added linkages and parts (idlers, compensating rods, supports, etc) were calculated. Detailed static stress analyses were then conducted for the cyclic and collective control beams mounted on the transmission, the collective compensating rod support (mounted on the underside of the transmission), the cyclic and collective idlers, the idler supports, the support beam and attachments, and finally, the new and revised control rods. Figure 71 shows the sign convention used in this analysis. The detailed structural analysis is given in Reference 17.

Loads Analysis

Transmission mount loads were calculated for all critical conditions given in Table 17 and the additional condition of high gross weight (9142 lb) steady-state 45-degree bank turn. Figures 72 and 73 show the transmission mount geometry used in these calculations, and Table 18 shows the load factors, angular accelerations, rotor loads and mast rotor torque components for the critical conditions.

The loads shown in Table 18 were transposed to loads acting on the transmission at the DAVI locations. The results of this transformation are given in Table 19.

¹⁷ Tarricone, Mank and Hardersen, STRESS ANALYSIS: ISOLATION SYSTEM/ AIRFRAME AND CONTROL SYSTEM MODIFICATIONS FOR THE BELL UH-1H ROTOR ISOLATION PROGRAM, Kaman Aerospace Corporation, Bloomfield, CT, Kaman Report S-119, September 1973.

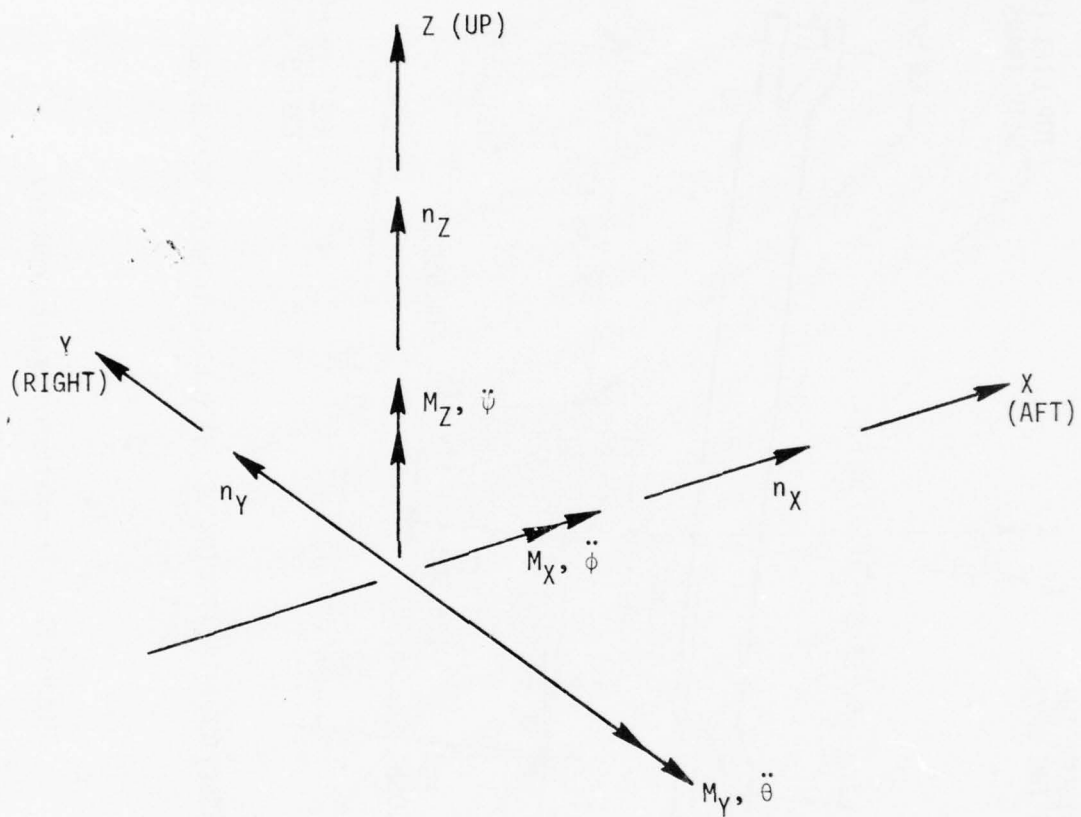

ALL FORCES, LOAD FACTORS, MOMENTS, ANGULAR ACCELERATIONS AND DIRECTIONS ARE POSITIVE AS SHOWN.

LEFT-HAND RULE FOR MOMENTS AND ANGULAR ACCELERATIONS.

Figure 71. Sign Convention

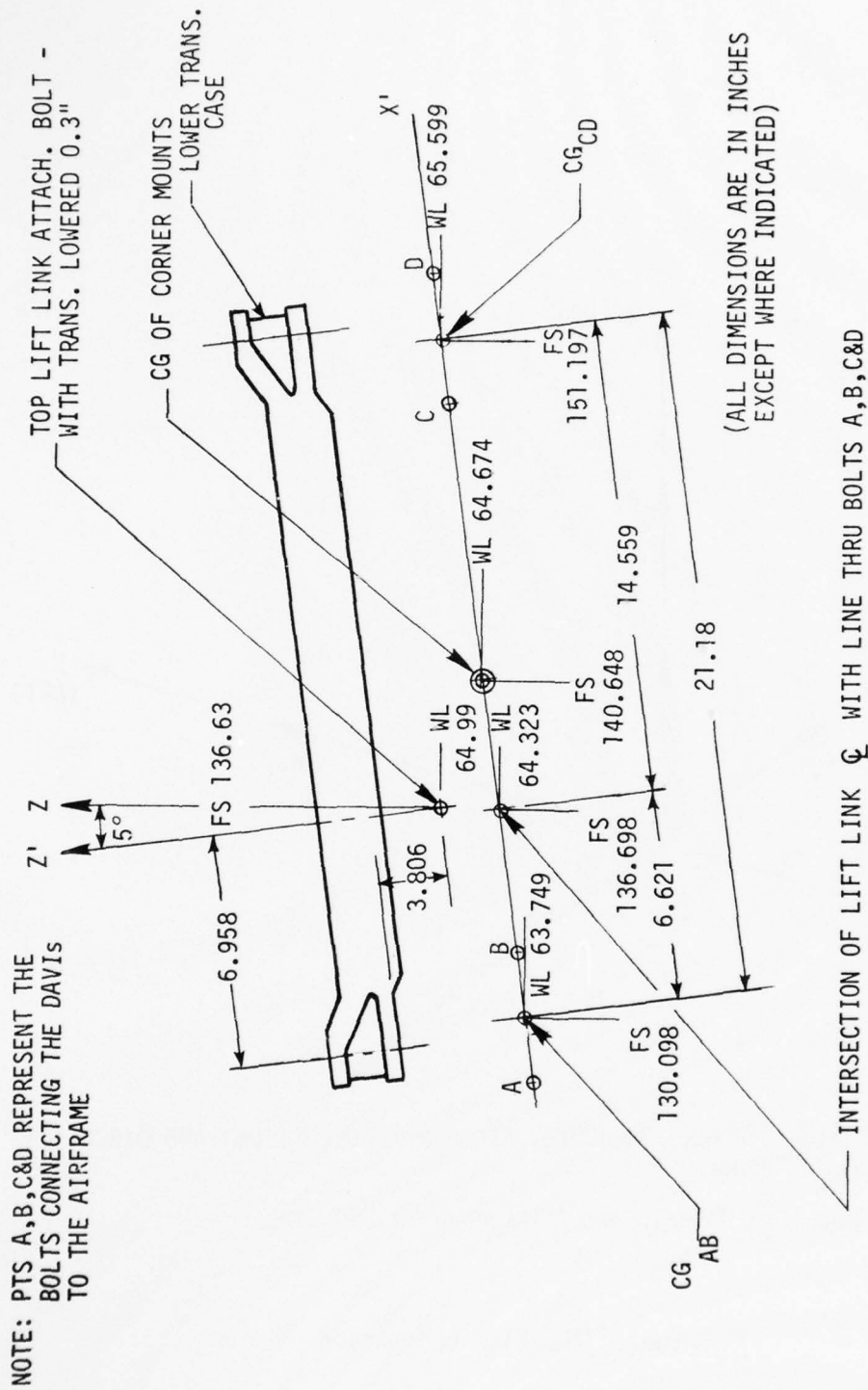
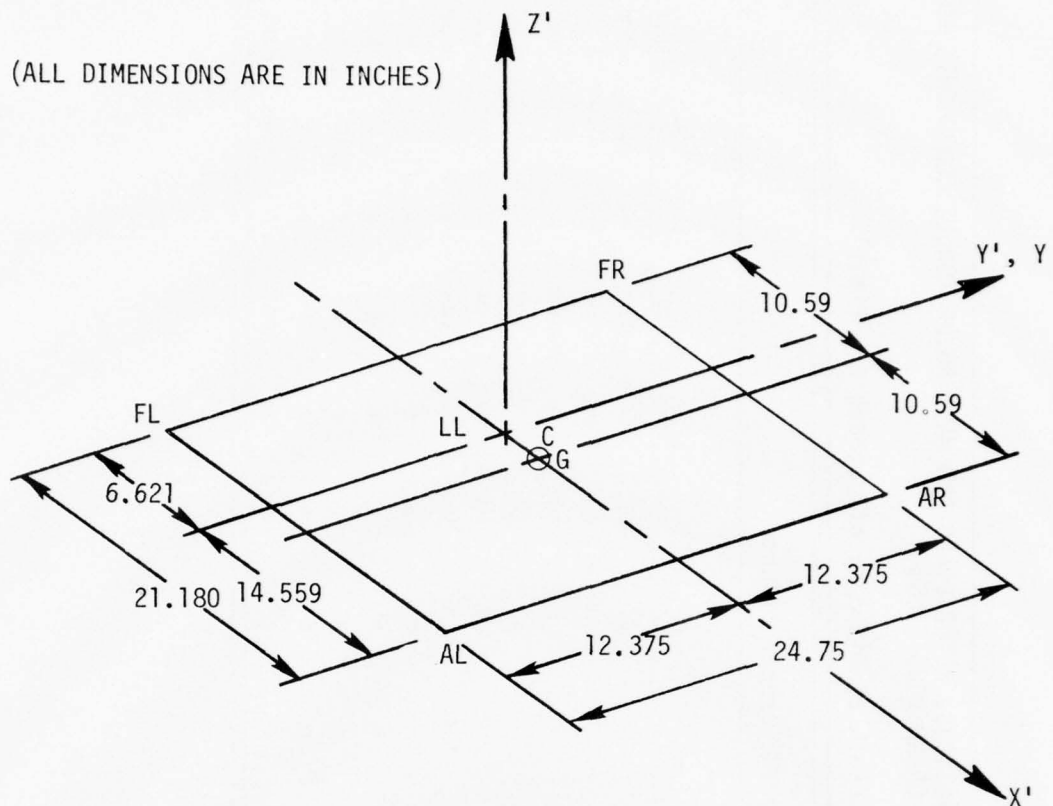

Figure 72. Transmission Mount Geometry



FL - FORWARD LEFT
 FR - FORWARD RIGHT
 AR - AFT RIGHT
 AL - AFT LEFT
 LL - LIFT LINK
 C_G - CENTROID OF 4
 CORNER MOUNTS

$$K_{Z'} = 6500\#/IN. = K_{X'}, K_{Y'} = 53,000\#/IN.$$

$$K_{Z'} = 10,000\#/IN.$$

AVAILABLE TRAVELS (FROM NEUTRAL)

CORNERS: UP: .462", DOWN: .316", FWD: 0.38", AFT: 0.38"
 LIFT LINK: UP: .34", DOWN: .22"

Figure 73. Idealized Mounting Plane Geometry, Mount Spring Rates and Motions

TABLE 18. LOAD FACTORS, ANGULAR ACCELERATIONS, ROTOR LOADS AND MAST ROTOR TORQUE COMPONENTS FOR CRITICAL FLIGHT, LANDING AND CRASH CONDITIONS
(Ultimate loads shown for crash conditions; all others are limit)

Helicopter Reference System

Condition	C.G. F.S.	n_x	n_y	n_z	$\ddot{\theta}$	$\ddot{\phi}$	$\ddot{\psi}$	F_{XR}	F_{YR}	F_{ZR}	D_R	T_{Mx} (in.-lb)	T_{Mz} (in.-lb)
II	130	0	0.03	3.00	-1.69	0	0	-1568	-341	20314	346	-14800	192400
Vb	130	0.35	-0.01	2.40	0	-0.11	-0.19	617	-668	17496	343	6740	192880
Vc	130	0.35	-0.02	2.40	0	2.27	3.86	617	500	17496	343	6740	192880
VI	130	0.14	0.44	0.99	0	0	0	-673	22	9433	328	-13750	192420
XIII	130	1.75	0	4.12	-4.60	0.21	0.04	165	-552	4400	0	7212	192865
XIV	130	0.03	-0.87	4.15	-0.42	14.44	2.14	165	-552	4400	0	7212	192865
8G Fwd Crash	-	8	0	0	0	0	0	0	0	0	0	0	0
8G Down Crash	-	0	0	8	0	0	0	0	0	0	0	0	0
8G Up Crash	-	0	0	-8	0	0	0	0	0	0	0	0	0
8G Side Crash	-	0	-8	0	0	0	0	0	0	0	0	0	0
45° Banked Turn	136.9	0.017	0	1.428	0	0	0	-640	-334	13144	0	-15888	192996

TABLE 19. SUMMARY - LIMIT[†] PYLON MOUNT LOADS*
(Loads shown are acting on the transmission)

Condition	Forward Left			Forward Right			Aft Left			Aft Right			Lift Link		
	R _x '	R _y '	R _z '	R _x '	R _y '	R _z '	R _x '	R _y '	R _z '	R _x '	R _y '	R _z '	R _x '	R _z '	R _{LL}
8G Fwd Crash	2470** 1004 _s	0	13013	2470** 1004 _s	0	13013	2470	0	-13952	2470	0	-13952	0	-13952	843
8G Side Crash	-5	-2944	-11457	5	-2944	11973	-5	-3000	-11457	5	-3000	11692	-3000	11692	-750
8G Down Crash	259	0	1905	259	0	1905	259	0	803	259	0	803	0	803	6427
8G Up Crash	-259	0	-2867	-259	0	-2867	-259	0	-1241	-259	0	-1241	0	-1241	-3627
II	427	-3746	-3119	-675	-3746	-2537	427	3940	-1558	-675	3940	-1558	4022	-675	-7642
	566	-4722	-4722	-814	-4722		566	4916	-814	-814	4916	-814	4916	-814	
Vb	140	-3704	-6321	-966	-3704	-7513	140	4022	1384	-966	4022	1384	4996	-966	-2772
	280	-4675	-4675	-1106	-4675		280	4998		-1106	4998			-1106	
Vc	139	-3895	-8912	-965	-3895	-6920	139	3807	1353	-965	3807	1353	3607	-965	-2772
	278	-4870	-4870	-1104	-4870		278	4782		-1104	4782		4782	-1104	
VI	516	-3696	-2236	-588	-3696	-1754	516	4012	-999	-588	4012	-999	4012	-588	-2474
	656	-4671	-4671	-728	-4671		656	4987		-728	4987		4987	-728	
XIII	971	-3715	-739	-135	-3715	-1143	971	4011	2046	-135	4011	2046	4011	-135	-108
	1111	-4691	-4691	-275	-4691		1111	4987		-275	4987		4987	-275	
XIV	552	-3413	2074	-576	-3413	-2342	552	4453	4305	-576	4453	4305	4453	-576	-100
	691	-4389	-4389	-715	-4389		691	5429		-715	5429		5429	-715	
45° Banked Turn	634	-3825	-2168	-486	-3825	-2709	634	3993	-1173	-486	3993	-1173	3993	-486	-3274
	774	-4801	-4801	-626	-4801		774	4969		-626	4969		4969	-626	

† Crash condition loads are ultimate.
* When double loads are shown, upper is with no torque factor and lower is with torque factor, except for 8G Fwd Crash - See ** below.
**2470# is load in mount, 1004_s is load in crash strap.

The design criteria for the cyclic and collective control systems are the same as those used by the Bell Helicopter Corporation. The summary of these loads is given in Table 20 and a schematic of the control system is given in Figures 74 and 75.

Static Structural Analyses

Detailed static stress analyses were done on all new and modified components of the test vehicle. These included analyses on the DAVI transmission mount, the crash-strap installation, the DAVI lift-link mount, the fittings and pylon mount carry-through structure, and the transmission case assembly. These analyses were based upon the loads given in Table 19.

A detailed static stress analysis was done on the cyclic and collective control modification. This analysis used the control jam loads given in Table 20.

The results of these analyses are given in Table 21. It is seen from these results that all components have positive margins of safety except the critical fastener, the door to bulkhead bolt (Milson Pan Head Sleeve Bolt - 1915 - 5-3), which has a negative margin of safety of 12 percent. This negative margin was considered to be conservative because all flight conditions include a torque factor of 1.25, and the loads used to analyze this fastener, located in bulkhead 129 below WL 54, were the higher loads associated with the local transmission support structure above WL 54. Further, the entire helicopter successfully passed a static test for a 45-degree banked turn - the most severe loading condition that would occur in the flight test phase.

DAVI Vibratory Loads

Two-per-rev hub vibratory forces were calculated for the UH-1H helicopter versus speed. These hub vibratory forces were then used in Kaman's twelve-degree-of-freedom rotor isolation program to determine DAVI vibratory loads. It was determined from this analysis that the maximum vibratory load for the DAVI transmission mounts would occur in the 116-knot flight condition, and the maximum vibratory load for the DAVI lift link mount would occur in the 70-knot flight condition. Table 22 gives the loads in the DAVI inertia bars for the respective maximum loading conditions, and Figure 76 indicates where these loads occur.

Fatigue Analysis

The loads given in Table 22 were used for the fatigue analysis on the DAVI mounts. The results of this analysis are given in Table 23. It is seen from this table that the vibratory stresses of all the components are within their respective endurance limits and infinite life can be expected. The DAVI mounts were subjected to a 100-hour endurance test to substantiate their fatigue characteristics for the flight-test program.

TABLE 20. CONTROL SYSTEM LOADS

Longitudinal Cyclic System				
Control Rods	Limit Load - Pounds			Jam Condition
	Stick Fwd	Stick Neut	Stick Aft	
LN & GH	379 569	358 537	370 555	One Pilot Effort 75% Two Pilot Effort
PQ & JK	406 609	390 585	399 599	One Pilot Effort 75% Two Pilot Effort
Lateral Cyclic System				
Control Rods	Limit Load - Pounds			Jam Condition
	Stick Left	Stick Neut	Stick Rt	
LN & GH	222 333	213 320	230 345	One Pilot Effort 75% Two Pilot Effort
PQ & JK	249 374	232 348	248 372	One Pilot Effort 75% Two Pilot Effort
Collective System				
Control Rods	Limit Load - Pounds			Jam Condition
	Stick Fwd	Stick Neut	Stick Aft	
JK	575 862	581 872	628 942	One Pilot Effort 75% Two Pilot Effort
LM	357 536	318 477	301 452	One Pilot Effort 75% Two Pilot Effort

CONTROLS INSTALLATION COLLECTIVE PITCH

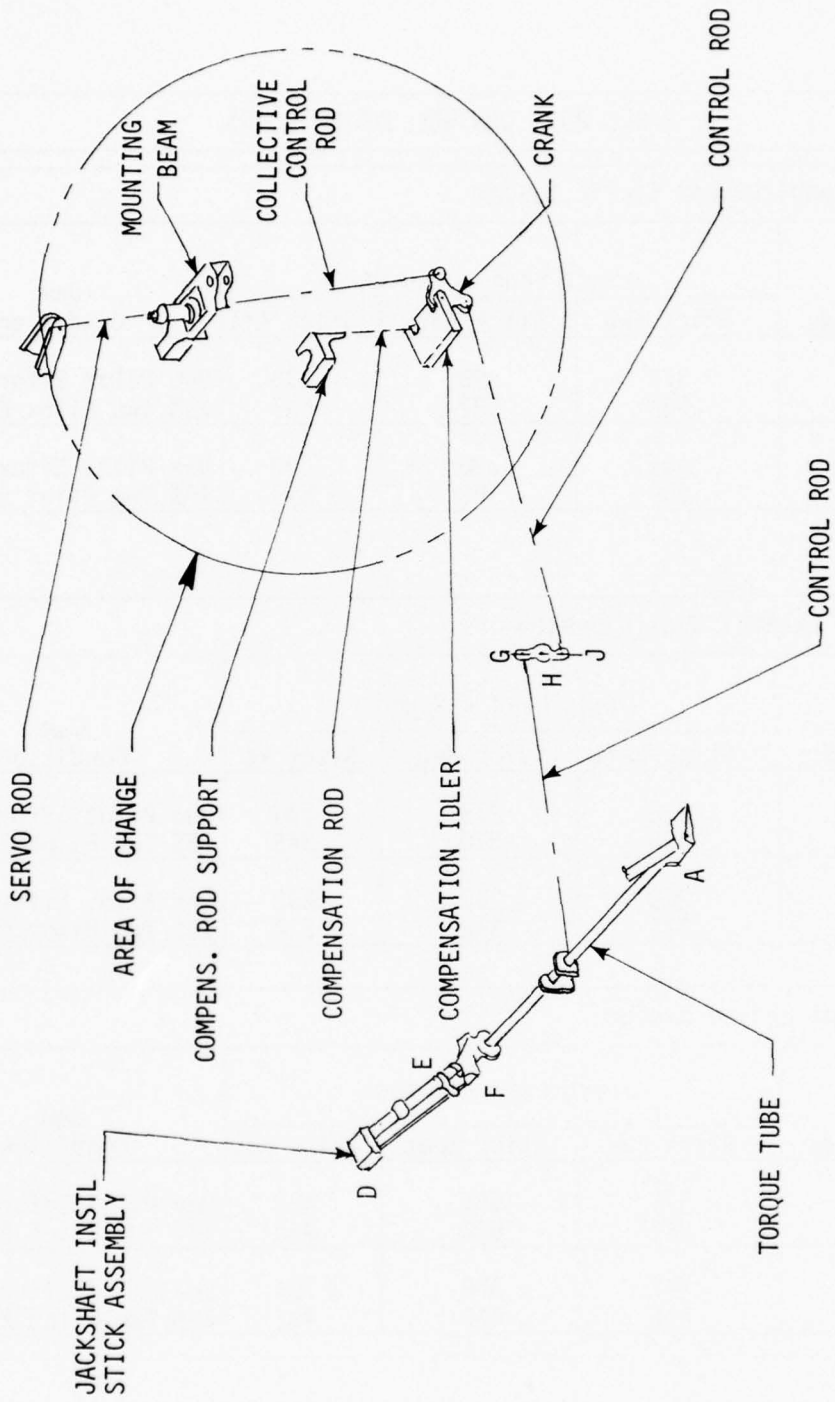
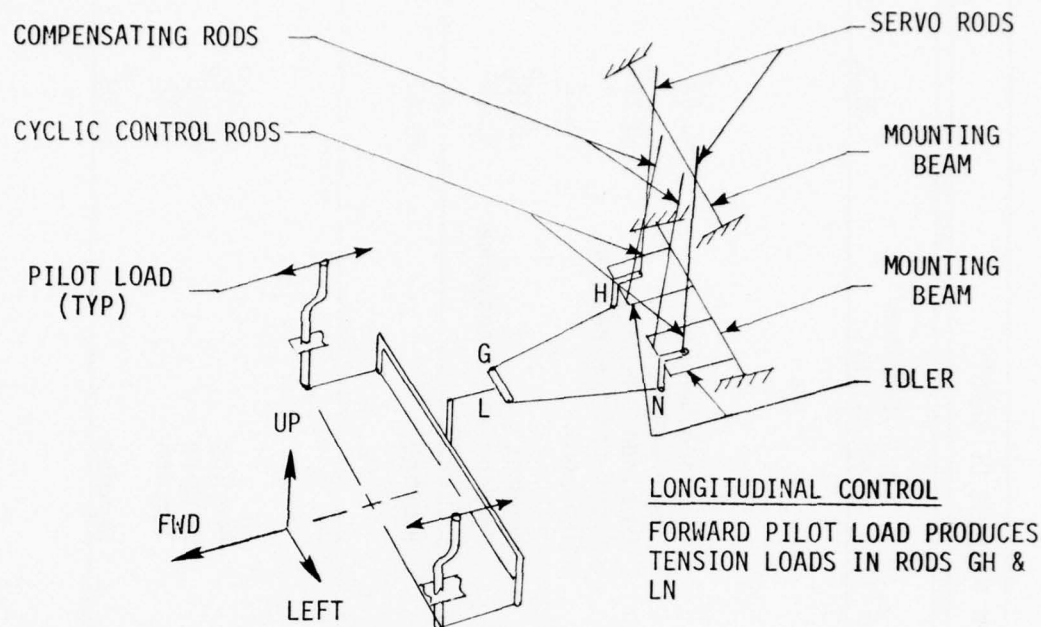

Figure 74. Collective Control Schematic



LATERAL CONTROL - LEFT PILOT LOAD PRODUCES COMPRESSION LOAD IN ROD GH AND TENSION LOAD IN ROD LN

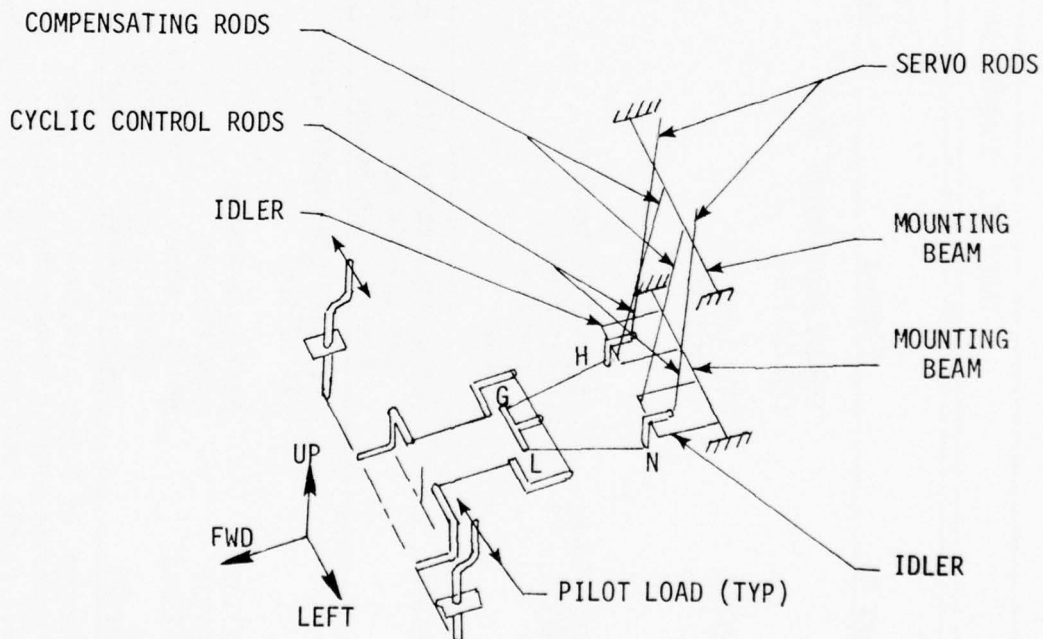

Figure 75. Cyclic Control Schematic

TABLE 21. SUMMARY OF MINIMUM* MARGINS OF SAFETY

Part No.	Element	Critical (1) Condition	Predicted Mode of Failure	M.S.
TRANSMISSION-MOUNT DAVI (XK 221101)				
XK 221115	DAVI Housing Spindle	Vc	Combined Bending, Shear and Tension	+0.04 ^P
	Top Plate	Vc	Combined Bending, Shear and Compression	+0.26 ^P
NAS 1229-10LW XK 221116	Attach Bolt to Trans Isolated Plate	Vc	Tension	+0.22
	Lug End	Vc	Bending	+0.18 ^P
	Lug	Vc	Bending and Transverse Lug Load	+0.28 ^P
XK 221014	CRASH STRAP INSTALLATION NAS 464 P3A Bolt & NAS 75-3-306 Spacer	8G Fwd Crash	Bending	+0.43
DAVI LIFT LINK MOUNT ASSY (XK 221106)				
XK 221130	Fail-Safe Plates	II	Bending	+0.19 ^P
XK 221134	Link Housing	II	Bending	+0.45 ^P
MS 21250-5	Bolts - Upper - Fail-Safe Plates to Link Housing	II	Tension	+0.92
XK 221132	Lower Cap Assy - Flange	II	Bending	+0.18 ^P

* Margins of Safety > +1.00 are not shown.
P Indicates plastic rather than elastic.
(1) All flight conditions are with torque factor.

TABLE 21 (Continued)

Part No.	Element	Critical Condition (1)	Predicted Mode of Failure	M.S.
	PYLON MOUNT CARRY-THRU STRUCTURE (XK 221003)			
XK 221004	Fitting - Fwd Support Fwd DAVI	Vc	Bending Shear	+0.50 ^P +0.40
MS 20426006 XK 221005	Inboard End (Angle Stub) Critical Attach Rivet Fitting - Aft Support Fwd DAVI	Vc Vc	Bending Torsion	+0.25 ^P +0.70
XK 221007	Critical Bending Section Critical Torsion Section Fitting - Aft DAVI & Aft Cant Bulk Support	Vb Vb	Bending Torsion	+0.24
MS 20470006	Critical Attach Rivet Upper Sill Fwd End	8G Fwd Crash	Shear	+0.39
205-030-163-185 & XK 221003-47	Lower Sill Inboard Cap Outboard Cap	Vb 8G Side Crash Vc	Crippling Crippling Crippling	+0.41 +0.61
3/16 Dia Hi-Lok Bolt XK 221011	Fastener - Clip to Lower Sill Lower Aft Door - Bulkhead 155-166, B.L. 14 Beam	Vc	Bearing	+0.34
Milson 1915-5 Steeve Bolt	Critical Panel Fastener	Vc	Bearing	+0.77

TABLE 21 (Continued)

Part No.	Element	Critical Condition (1)	Predicted Mode of Failure	M.S.
	PYLON MOUNT CARRY-THRU STRUCTURE (XK 221003) (Continued)			
205-030-708 & XK 221001 Rev A	Bulkhead Sta 129 - Fwd Cant, Center Fuselage	Vc	Tension	+0.14
205-030-163-101	Corner Cap Angle	Vc	Shear Crippling - Intercell	+0.12
205-030-872-47	Door - Facing	Vc	Interbolt Buckling	+0.26
"	Door - Edge	Vc	Bearing	-0.12
Milson Pan Head Sleeve Bolt - 1915-5-3	Critical Fastener - Door to Bulkhead	Vc		
205-030-953-25	Door Edge	Vc	Interbolt Buckling	+0.33
"	Critical Fastener - Door to Bulkhead	Vc	Bearing	+0.27
AW 525-10 Screw	Critical Fastener - XK 221020-11 Door to Bulkhead	Vc	Bearing	+0.40
MS 20426AD Rivet	Critical Fastener in 205-030-708-75 Support	Vc	Bearing	+0.10
205-030-919 & XK 221002	Bulkhead Sta 155 - Aft Cant, Center Fuselage Caps Web	XIV XIV	Crippling Shear	

TABLE 21 (Continued)

Part No.	Element	Critical (1) Condition	Predicted Mode of Failure	M.S.
	CYCLIC & COLLECTIVE CONTROL SYSTEM INSTALL. (XK 221201)			
XK 221202	Beam Assy - Fwd Cyclic Control Support			
	Lower End Plate	Longit Jam	Bending and Axial Load	+0.14 ^P
	Upper End Plate	Longit Jam	Bending and Axial Load	+0.21 ^P
	Vertical End Plate	Longit Jam	Bending and Torsion	+0.11
XK 221203	Beam Assy - Aft Collect. Control Cylinder Mounting			
	Upper End Plate	Collect. Jam	Bending and Torsion	+0.32
	Lower End Plate	Collect. Jam	Bending and Compression	+0.15
XK 221214	Support Assy - Collect. Compensat Rod Attach.			
AN 126012 Stud	Critical Fastener - Oil Pump Stud	Collect. Jam	Tension	+0.46
XK 221206	Idler Assy - Collective Control			
NAS 464 Bolt	Attach Bolt	Collect. Jam	Bending	+0.93 ^P
XK 221210	Collective Control Rod Assy			
	Column	Collect. Jam	Compression	+0.37
XK 221213	Cyclic Compensating Rod Assy			
	Column	Longit Jam	Compression	+0.47

TABLE 21 (Concluded)

Part No.	Element	Critical (1) Condition	Predicted Mode of Failure	M.S.
	SUPPORT INSTALLATION - CONTROLS, STA 141 (XK 221017)			
XK 221017-11 Lower	Beam Flange & Web as Tension Clip	Collect. Jam	Bending	+0.18
XK 221017-11 Upper Shur-Lok SL2-3-500-1SP Shur-Lok Honey- comb Panel Fastener	Attachment - XK 221017-19 Clip to 205-030-229 and 228 Panel	Cyclic Jam Collect. Jam	Bending Bond Shear	+0.87 +0.10

TABLE 22. DAVI INERTIA BAR LOADS				
DAVI Mount	Load			
	Non-Isolated Pivot-Transmission	Isolated Pivot (Fuselage)	Inertia Weight	
			Force	Moment
Transmission	+626 lb	+718 lb	+92 lb	+84 in.-lb
Lift Link	+172 lb	+204 lb	+32 lb	+11 in.-lb

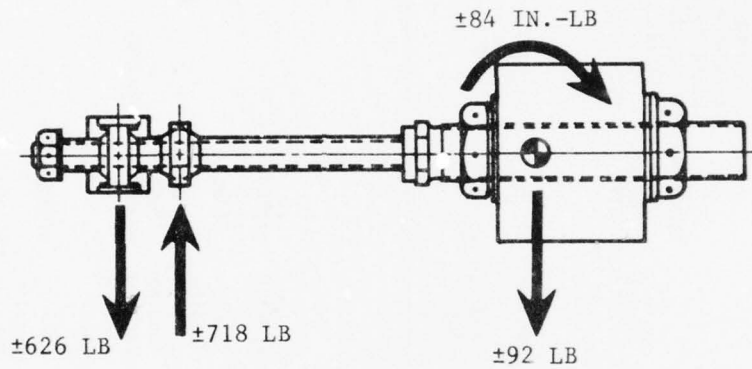

A. Transmission DAVI Inertia Bar

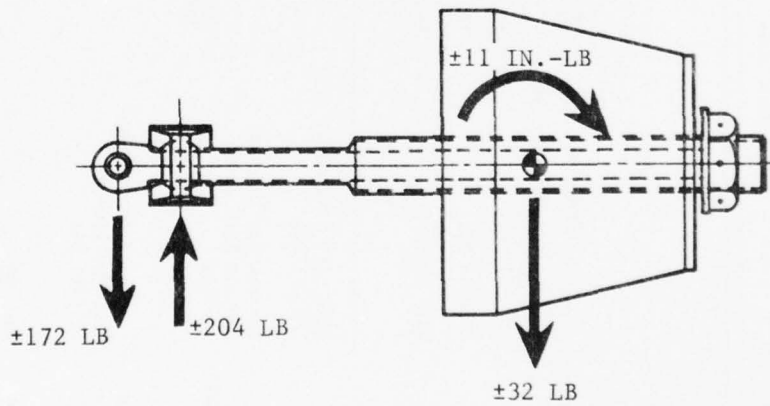

B. Lift Link DAVI Inertia Bar

Figure 76. Inertia Bars

TABLE 23. SUMMARY OF FATIGUE ANALYSES

Part No.	Element	Condition	Stress	Endurance Limit (psi)	Reduced Endurance Limit Due to Steady Stress (psi)	Notched Endurance Limit (psi)	Total Vibratory Stress (psi)	Life * (hr)
TRANSMISSION MOUNT DAVI (XK 221101)								
XK 221111	Inertia Bar	Level Flt 116K	Bending	+25000	+17600	-	+16656	∞
XK 221115	DAVI Housing	Level Flt 116K	Bending Plus Axial	+18000	-	+17200	+ 6565	∞
DAVI LIFT LINK MOUNT ASSY (XK 221106)								
MS 21250-5	Inertia Bar to Link Housing Assy Joint Bolt	Level Flt 70K	Bending	+18000	-	-	+12000	∞
XK 221129	Lug of Link Assy	"	Hoop Tension	+18000	-	+3400	+1140	∞
XK 221128	Lug of Inertia Bar	"	"	+18000	-	+4100	+1110	∞
XK 221127	Threaded Sleeve	"	Bending Plus Axial	+25000	+17600	+7200	+1765	∞
XK 221128	Inertia Bar	"	"	+25000	+17600	-	+3660	∞
XK 221134	Housing Lug	Level Flt 70K	Hoop Tension	+18000	-	+9000	+335	∞
	Bending Section	"	Bending	+18000	-	+9000	+1325	∞
* For straight and level flight. Fatigue damage was not estimated for maneuvers.								

FLYING QUALITIES ANALYSIS

A flying qualities analysis was done to determine if there were any appreciable changes due to the installation of the DAVI system and is reported in Reference 18. The evaluation compares trim and controllability, speed stability, characteristics in steady sideslip, response to controls in hover, and stick fixed stability of both systems.

Figure 77 shows the longitudinal trim and control requirements of the DAVI and standard systems. It is seen from this figure that there is no appreciable difference between the two systems, and it indicates no unacceptable reversals of stick gradient or other static flight characteristics due to the installation of the DAVI.

Speed stability is the initial tendency of the aircraft to maintain speed and is usually measured by the longitudinal stick motion required to adjust to a speed disturbance. Figure 78 shows the results of this analysis. It is seen that there is negligible difference between the speed stabilities of the two isolation systems.

Figure 79 shows the required pedal position and lateral stick positions for holding a steady slide slip for the DAVI and standard systems at 60 and 100 knots. It is seen from this figure that the static directional stability of the two systems at both speeds are not appreciably different.

The initial response of the helicopter to pitch and roll control in hovering flight is specified in MIL-11-8501A to be a function of control sensitivity and initial rotary damping. These requirements for the 8250-pound UH-1H are shown in Figure 80. The capabilities of the UH-1H for both the standard and DAVI system are indicated by the symbols. Figure 80 indicates a negligible difference in control sensitivity and damping between the two configurations.

Table 24 shows the results of the stick-fixed stability analysis. This table gives damping ratios, time to half or double amplitude of the oscillation, period and natural frequencies of the phugoid and short period modes in the longitudinal direction, and dutch roll and spiral divergence modes in the lateral direction.

¹⁸ Fitzpatrick, FLYING QUALITIES COMPARISON OF UH-1H WITH TWO ROTOR ISOLATION SYSTEMS, Kaman Aerospace Corporation, Bloomfield, CT, Kaman Report P-66, September 1974.

GW: 8250 LB
 CG: STATION 138.6
 SL: STANDARD DAY

--- DAVI
 --- STANDARD

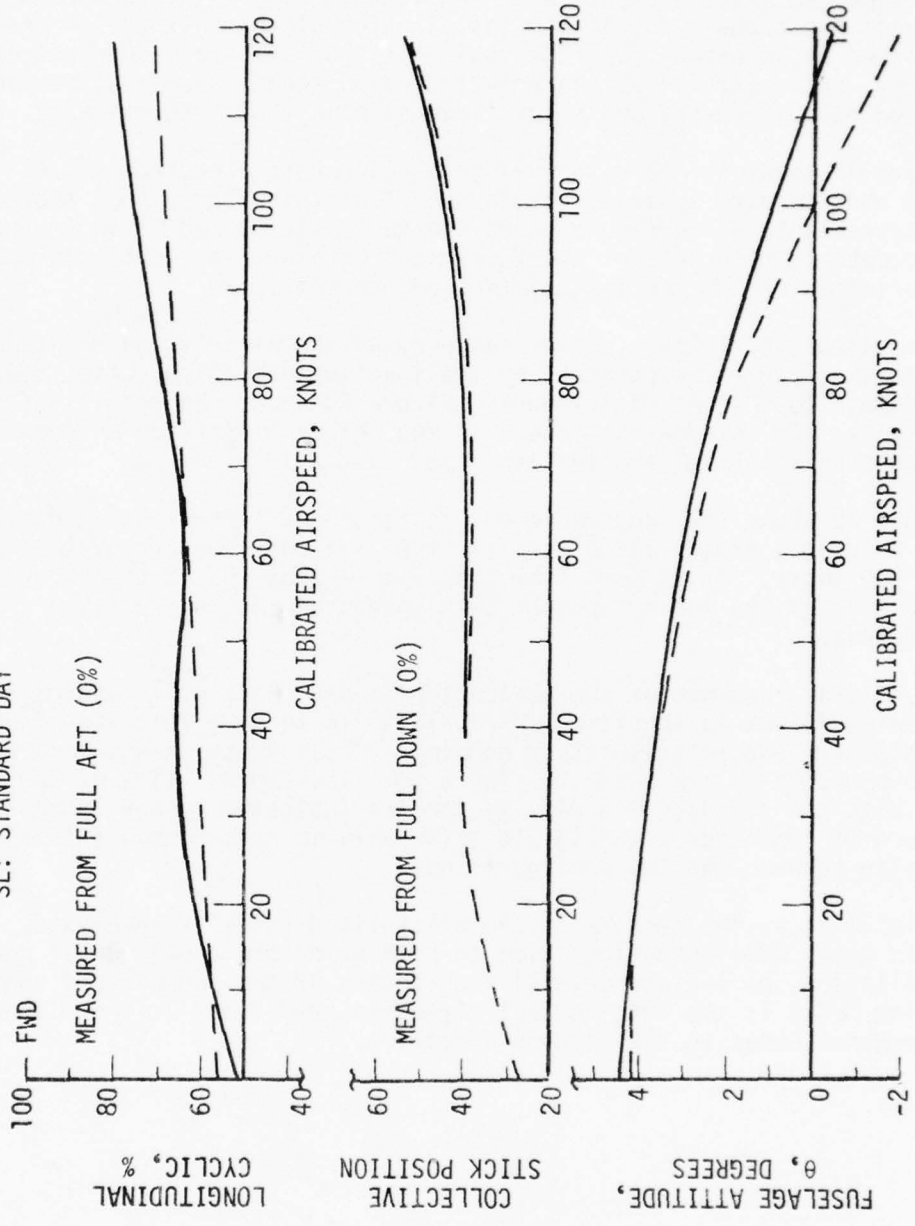

Figure 77. UH-1H Trim Characteristics With Two Rotor Isolation Systems

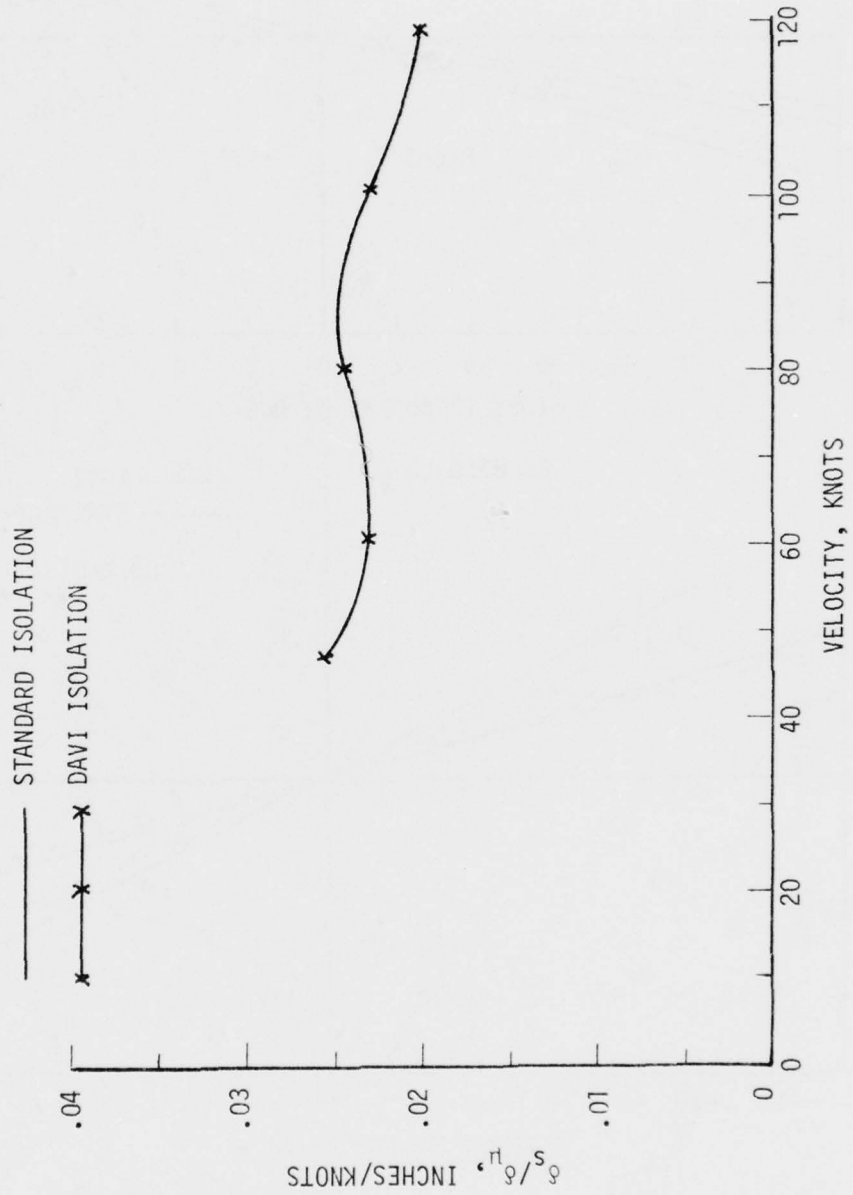

Figure 78. UH-1 Speed Stability With Standard Isolation and DAVI Isolation

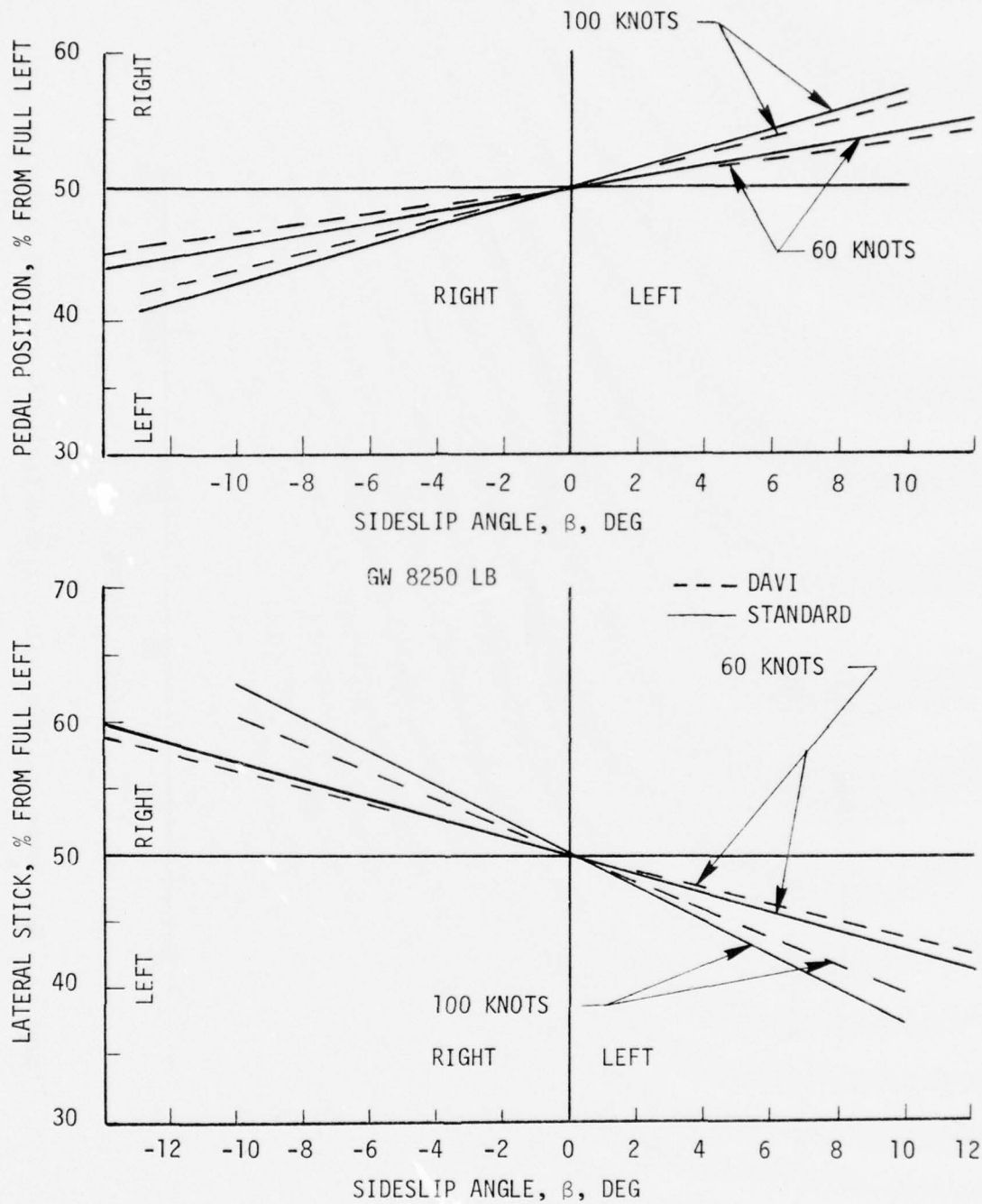

Figure 79. Effect of DAVI Isolation on UH-1H Steady Sideslip

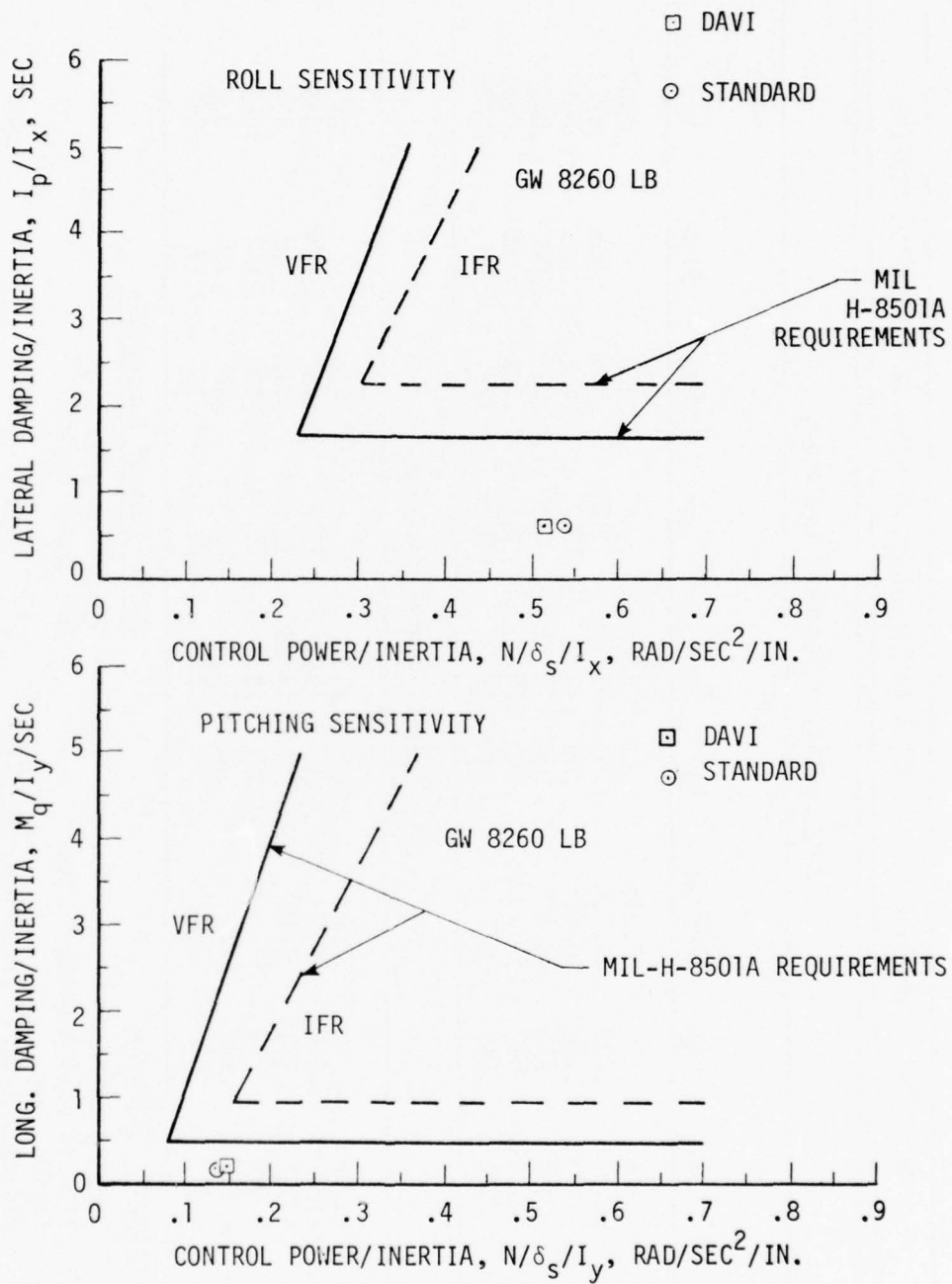

Figure 80. Effect of Isolation System on Control Response.

TABLE 24. SUMMARY OF UH-1H STICK FIXED STABILITY WITH TWO ISOLATION SYSTEMS

Longitudinal - Standard Isolators										
V (kt)	ζ_{PW}	ζ_{SP}	$t_{1/2xPH}$	t_{SP}	T_{PH}	T_{SP}	ω_{nPH}	ω_{nSP}	C_{PH}	C_{SP}
0	-.364	-	7.07*	1.37	25.0	-	.274	-	.040	-
47	-.154	.798	9.73*	1.07	13.75	12.88	.463	.808	.0727	.0777
60	-.149	.835	10.74*	.99	14.7	13.7	.432	.835	.068	.0732
80	-.055	.745	32.35*	.94	16.11	9.5	.39	.98	.062	.104
100	.0192	.647	113.5 sec	.89	19.7	6.8	.319	1.196	.0507	.145
119	.043	.615	58.7	.84	22.9	5.95	.27	1.34	.0436	.168
Longitudinal - DAVI Isolators										
0	-.358	-	7.1	1.35	24.6	-	.273	-	.040	-
47	-.22	.886	6.2	1.0	13.3	17.4	.487	.779	.075	.057
60	-.28	.974	5.15	.90	14.08	35.0	.466	.791	.071	.029
80	-.099	.798	17.1	.92	15.4	11.08	.408	.941	.065	.090
100	-.087	.794	21.3	.85	16.8	10.1	.37	1.02	.059	.099
119	-.11	.83	18.0	.79	17.9	10.7	.35	1.05	.056	.094
Definition of Symbols										
ζ	Damping Ratio									
$t_{1/2x}$	Time to Half Amplitude, Sec									
T	Period, Sec									
ω_n	Undamped Natural Frequency, Rad/Sec									
C	Damped Frequency, Cycles/Sec									
* Indicates Time to Double Amplitude										
Definition of Subscripts										
										PH
										SP
										Phugoid Mode
										Short Period

TABLE 24 (Concluded)

Lateral/Directional - Standard Isolators							
V (kt)	ζ_{DR}	$t_1/2x_{DR}$	$t_1/2$ S.Div	t_{DR}	ω_n_{DR}	C_{DR}	
0	-.1605	9.7*	1.45	14.3	.44	.07	
47	.49	1.2	2568.*	5.95	1.213	.168	
60	.342	1.35	16.2	4.47	1.50	.224	
80	.344	1.13	28.1	3.75	1.79	.267	
100	.273	1.188	16.8	3.05	2.14	.33	
119	.348	.90	145.0	3.00	2.23	.333	
Lateral/Directional - DAVI Isolators							
0	-.169	9.25	1.51	14.37	.444	.070	
47	.33	1.68	9.5	5.3	1.26	.189	
60	.334	1.41	13.1	4.52	1.47	.221	
80	.344	1.13	32.1	3.75	1.78	.266	
100	.345	1.00	53.3	3.31	2.02	.302	
119	.355	.90	73.5	3.08	2.18	.325	
Definition of Symbols							
ζ	Damping Ratio						
$t_1/2x$	Time to Half Amplitude, Sec						
T	Period, Sec						
ω_n	Undamped Natural Frequency, Rad/Sec						
C	Damped Frequency, Cycles/Sec						
*	Indicates Time to Double Amplitude						
Definition of Subscripts							
DR				Dutch Roll			
S.Div				Spiral Divergence			

It is seen from Table 24 that, for the phugoid mode, the damping ratios for the DAVI system are slightly less stable than for the standard system for all speeds except hover. However, the period and time to double amplitude are sufficiently large so that no significant deterioration in the aircraft handling qualities is expected. In the short period mode, the two systems show essentially the same times to half amplitude, although the DAVI system characteristics will be more favorable due to the longer period. In the lateral/directional sense, the damping ratios and periods of the Dutch roll mode are almost identical. Time to half amplitude in the spiral mode indicates that the aircraft with the standard system is slightly less stable than the DAVI system.

It can be concluded from the comparison of the results obtained for the DAVI and standard systems in this flying qualities analysis that the DAVI system does not appreciably change the flying qualities of the aircraft.

OPERATING LIMITS OF THE DAVI-MODIFIED UH-1H

DAVI Travel Requirements

The initial design criteria for the travel requirements of the DAVI were to withstand rotor load factors of +3.00g and -.5g for the design gross weight of 6600 pounds for a ramp of 0.6 second without bottoming. A transient analysis as a function of speed was done for vertical load factors. The load factor was reduced to stay within the stall limitations of the rotor. However, propulsive force versus speed was also considered. Table 25 shows the results of this analysis.

TABLE 25. DAVI TRAVEL REQUIREMENTS				
Velocity (knots)	Load Factor N_z	Travel - Inch		
		Forward	Lift Link	Aft
0	3.0	.7015	.4915	.0469
60	2.64	.5695	.4177	.0962
80	2.35	.4133	.3313	.1578
120	1.77	.2314	.2372	.2497
130	1.64	.1662	.2045	.2855
0	-.5	-.1167	-.0818	-.0078

It is seen from Table 25 that the forward transmission-mount DAVIs have the greatest travel requirement - .8182 inch (.7015 inch up and .1167 down). The travel requirement of the lift-link DAVI is .5733 (.4915 inch up and .0818 inch down).

In the actual travel designed into the DAVIs, essentially the total available travel was retained. However, the travel was intentionally biased by reducing the up travel and increasing the down travel to prevent bottoming in a hard landing. Table 26 shows the actual travels in the DAVIs.

TABLE 26. MAXIMUM TRAVEL OF DAVI DESIGN						
Location	Travel - Inch					
	Metal-to-Metal			Elastomer-to-Elastomer		
	Up	Down	Total	Up	Down	Total
Transmission	.582	.436	1.018	.462	.316	.778
Lift Link	.360	.240	.600	.340	.220	.560

It is seen from this table that the DAVIs have been designed to have rubber-to-rubber bottoming and not metal-to-metal. The maximum deflection is .778 inch in the transmission DAVIs and is .560 inch in the lift-link DAVI before elastomer-to-elastomer contact.

Flight Conditions

In order to determine the operating limits of the DAVI-modified UH-1H helicopter, rotor forces and moments were calculated for various gross weights and cg locations of the vehicle. The conditions calculated were for a collective pull-up hover maneuver, trimmed level flight, and constant bank angle turns. The criterion for flight limitation was the bottoming of any one DAVI. Table 27 gives a summary of these flight conditions.

Hover - Collective Pull-Up Conditions (V = 0 Knots)

A total of 21 conditions were considered, 12 at a gross weight of 6600 lb and 9 at 9140 lb. All cases were investigated for a most-forward, a mid and a most-aft cg (stations 130, 137 and 144). For the 6600-lb gross weight, helicopter vertical load factors of 1.0, 1.5, 2.0 and 3.0 were used; for the 9140-lb gross weight, 1.0, 1.25 and 1.5 were used. These conditions are given in Table 27.

TABLE 27. SUMMARY OF FLIGHT CONDITIONS

TABLE 27. SUMMARY OF FLIGHT CONDITIONS									
Condition	No.	GW (lb)	CG Sta	V (kt)	n _z	Rotor Hub Forces			Rotor Shaft Torque
						F _{XR} (lb)	F _{YR} (lb)	F _{ZR} (lb)	T _{in.-lb}
Hover, Collect. Pull-Up	1	6600	130	0	1.0	251	-201	6595	122550
	2	"	144	"	1.0	-901	-203	6538	122550
	3	"	137	"	1.0	-327	-203	6592	122550
	4	"	130	"	1.5	376	-302	9893	183825
	5	"	144	"	1.5	-1351	-304	9807	183825
	6	"	137	"	1.5	-491	-304	9888	183825
	7	"	130	"	2.0	502	-315	13190	192000
	8	"	144	"	2.0	-1802	-317	13076	192000
	9	"	137	"	2.0	-654	-317	13184	192000
	10	"	130	"	3.0	753	-315	19786	192000
	11	"	144	"	3.0	-2703	-317	19615	192000
	12	"	137	"	3.0	-982	-317	19776	192000
	13	9140	137	"	1.0	-448	-200	9131	122550
	14	"	137	"	1.25	-559	-250	11414	153187
	15	"	137	"	1.5	-671	-300	13687	183825
	16	"	130	"	1.0	345	-200	9133	122550
	17	"	130	"	1.25	432	-250	11417	153187
	18	"	130	"	1.5	518	-300	13700	183825
	19	"	144	"	1.0	-1232	-200	9056	122550
	20	"	144	"	1.25	-1540	-250	11321	133187
	21	"	144	"	1.5	-1848	-300	13585	183825
Trimmed Level Flight, Fwd Speed	22	8250	130	50	1.0	-45	-251	8407	89148
	23	"	130	65	1.0	-16	-260	8575	89532
	24	"	130	80	1.0	-78	-282	8760	98436
	25	"	130	95	1.0	-102	-332	9014	114672
	26	"	130	111	1.0	-160	-407	9404	140688
	27	"	138.5	50	1.0	-849	-148	8343	87792
	28	"	138.5	65	1.0	-785	-158	8352	87072
	29	"	138.5	80	1.0	-811	-172	8412	93772
	30	"	138.5	95	1.0	-802	-208	8509	108913
	31	"	138.5	111	1.0	-840	-257	8722	132144
	32	"	144	50	1.0	-1411	-73	8315	87720
	33	"	144	65	1.0	-1329	-83	8233	85884
	34	"	144	80	1.0	-1321	-94	8216	93012
	35	"	144	95	1.0	-1293	-119	8204	108276
	36	"	144	111	1.0	-1295	-156	8335	131844
	37	9140	130	50	1.0	-24	-297	9359	112308
	38	"	130	65	1.0	6	-303	9473	113676
	39	"	130	80	1.0	-25	-327	9586	115032

TABLE 27 (Continued)

Condition	No.	GW (lb)	CG Sta	V (kt)	n _z	Rotor Hub Forces			Rotor Shaft Torque
						F _{XR} (lb)	F _{YR} (lb)	F _{ZR} (lb)	T _{in.} -lb
Trimmed	40	9140	130	95	1.0	71	-385	9946	119352
Level	41	"	130	111	1.0	-129	-462	10320	123840
Flight,	42	"	138.5	50	1.0	-915	-178	9239	110868
Fwd	43	"	138.5	65	1.0	-848	-186	9245	110940
Speed	44	"	138.5	80	1.0	-856	-204	9332	111864
(Cont)	45	"	138.5	95	1.0	-867	-241	9437	113244
	46	"	138.5	111	1.0	-895	-297	9644	115728
	47	"	144	50	1.0	-1500	-96	9217	110604
	48	"	144	65	1.0	-1448	-100	9130	109560
	49	"	144	80	1.0	-1428	-113	9108	109296
	50	"	144	95	1.0	-1412	-139	9103	109236
	51	"	144	111	1.0	-1454	-177	9320	111840
Constant	52	8250	130	50	1.25	106	-389	10508	130392
Bank	53	"	130	65	1.25	150	-403	10731	129672
Angle	54	"	130	80	1.25	56	-389	10805	127212
Turns	55	"	130	95	1.25	-2	-433	11047	191252
	56	"	130	111	1.25	-52	-512	11377	165624
	57	"	138.5	50	1.25	-900	-237	10317	129036
	58	"	138.5	65	1.25	-871	-236	10402	121524
	59	"	138.5	80	1.25	-880	-249	10386	125784
	60	"	138.5	95	1.25	-915	-277	10588	136152
	61	"	138.5	111	1.25	-943	-324	10729	155832
	62	"	144	50	1.25	-1696	-116	10277	131412
	63	"	144	65	1.25	-1636	-118	10283	117832
	64	"	144	80	1.25	-1644	-123	10272	119868
	65	"	144	95	1.25	-1526	-160	10240	131616
	66	"	144	111	1.25	-1580	-191	10408	152580
	67	"	130	50	1.5	127	-558	12562	188820
	68	"	130	65	1.5	176	-549	12729	176964
	69	"	130	80	1.5	135	-550	12813	174480
	70	"	130	95	1.5	104	-631	13201	195468
	71	"	138.5	50	1.5	-1084	-335	12377	185364
	72	"	138.5	65	1.5	-974	-349	12460	173520
	73	"	138.5	80	1.5	-1000	-353	12519	170256
	74	"	138.5	95	1.5	-1024	-364	12559	170724
	75	"	144	50	1.5	-2042	-164	12545	190092
	76	"	144	65	1.5	-1887	-179	12298	173616
	77	"	144	80	1.5	-1896	-186	12310	165888
	78	"	144	95	1.5	-1792	-218	12266	169620

TABLE 27 (Concluded)

Condition	No.	GW (lb)	CG Sta	V (kt)	n _z	Rotor Hub Forces			Rotor Shaft Torque
						F _{XR} (lb)	F _{YR} (lb)	F _{ZR} (lb)	T _{in.-lb}
Constant	79	9140	130	50	1.25	76	-465	11636	157820
Bank	80	"	130	65	1.25	123	-459	11772	148692
Angle	81	"	130	80	1.25	85	-478	11922	153012
Turns	82	"	130	95	1.25	28	-528	12159	167808
(Cont)	83	"	138.5	50	1.25	-996	-292	11492	156624
	84	"	138.5	65	1.25	-936	-292	11486	146544
	85	"	138.5	80	1.25	-967	-301	11562	147792
	86	"	138.5	95	1.25	-995	-330	11692	157680
	87	"	144	50	1.25	-1792	-152	11491	158640
	88	"	144	65	1.25	-1697	-167	11397	146964
	89	"	144	80	1.25	-1722	-170	11357	146280
	90	"	144	95	1.25	-1752	-185	11449	152904
	91	"	144	111	1.25	-1732	-232	11441	177996
	92	"	130	50	1.38	111	-579	12832	194328
	93	"	130	65	1.42	172	-614	13180	196344
	94	"	130	80	1.42	133	-639	13574	199584
	95	"	130	95	1.35	61	-613	13100	191148
	96	"	138.5	50	1.39	-1122	-354	12693	193500
	97	"	138.5	65	1.47	-1113	-404	13423	202608
	98	"	138.5	80	1.44	-1090	-392	13177	188844
	99	"	138.5	95	1.41	-1083	-423	13126	195312
	100	"	144	50	1.37	-2076	-171	12675	192276
	101	"	144	65	1.43	-2016	-203	13005	189564
	102	"	144	80	1.45	-2012	-220	13065	189036
	103	"	144	95	1.44	-1956	-221	12889	176376

The operating envelope for this class of conditions is given in Figure 81. At each gross weight, the "do not exceed" load factor boundary (beyond which DAVI bottoming will occur) is made up of three intersecting lines. Each line represents bottoming for a particular DAVI location - forward right (FR), lift link (LL) and aft right (AR). The maximum limit load factor at weights greater than the basic structural design gross weight (6600 lb) is determined by multiplying the design limit load factor of 3.0 by the ratio of structural design gross weight to the gross weight in question. For example, the maximum permissible load factor at a gross weight of 9140 lb is:

$$n_z = 3.0 \times \frac{6600}{9140} = 2.17$$

Trimmed Level Flight, Forward Speed Conditions

A total of 30 conditions were considered - 15 at a gross weight of 8250 lb and 15 at 9140 lb. All cases were investigated for a forward, a mid and an aft cg (stations 130, 138.5 and 144), and with each cg, five forward speeds were used: 50, 65, 80, 95 and 111 knots. These conditions are given in Table 27.

After calculating loads at each DAVI location for the 30 conditions considered, it was found that no DAVI bottoming occurs within the cg limits specified for the two gross weights considered. Thus, the DAVI installation imposes no limitations on the UH-1H helicopter, as seen in Figure 82.

Trimmed Constant Bank Angle Turn Conditions

A total of 52 conditions were considered - 27 at a gross weight of 8250 lb and 25 at 9140 lb. All cases were investigated for a forward, a mid and an aft cg (stations 130, 138.5 and 144.0). At 8250 lb, five forward speeds were used at each of the three cg's, and load factors of 1.25 and 1.5 were considered for each forward speed except that only the 1.25-load factor was considered at the 111-knot forward speed. At 9140 lb, four forward speeds were used at each of the three cg's. A load factor of 1.25 and that load factor which would result in a rotor shaft torque requirement at or near the basic transmission power limitation of the UH-1H (192,000 inch-pounds) were considered at each forward speed. These conditions are given in Table 27.

The operating envelope for this class of conditions is given in Figure 83. At each gross weight, the "do not exceed" load factor boundary (beyond which DAVI bottoming will occur) is denoted by the sloping lines. The horizontal lines are dictated by the standard UH-1H transmission power limitation, which is 192,000 inch-pounds of shaft torque. Note that all speeds fit inside a band no wider than $n_z = 0.1$.

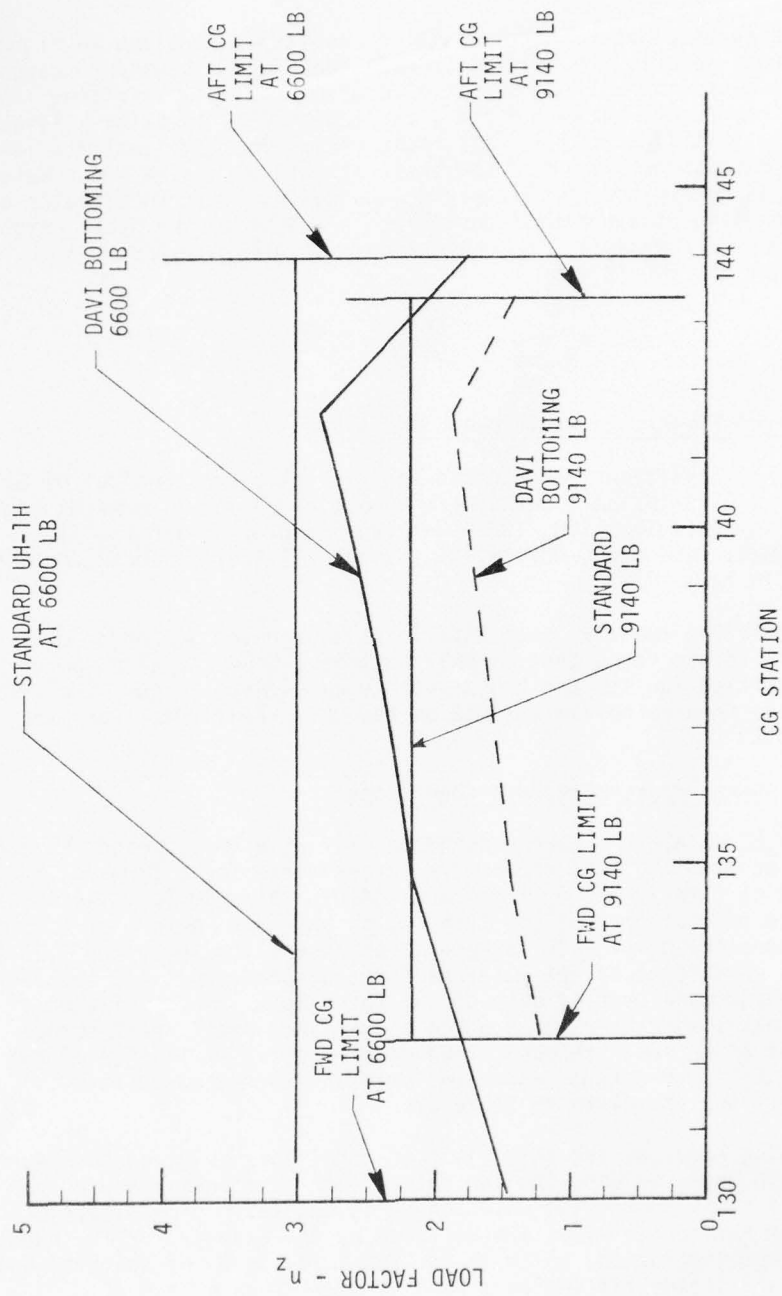

Figure 81. Operating Envelope, Bottoming Load Factor vs CG Station for the Hover-Collective Pull-Up Condition

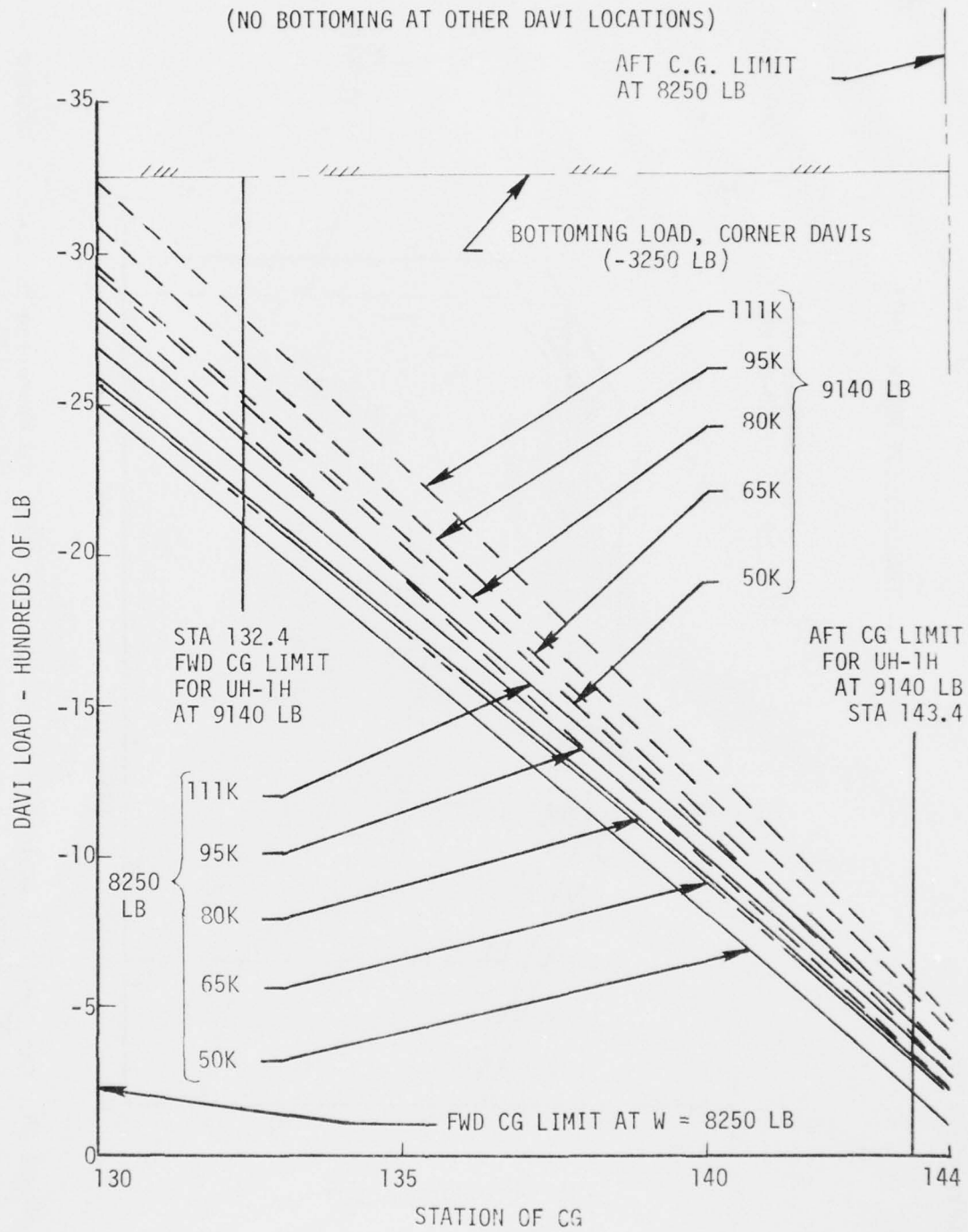

Figure 82. DAVI Load Vs CG Station - Right Fwd DAVI, Trimmed Level Flight Forward Speed Conditions

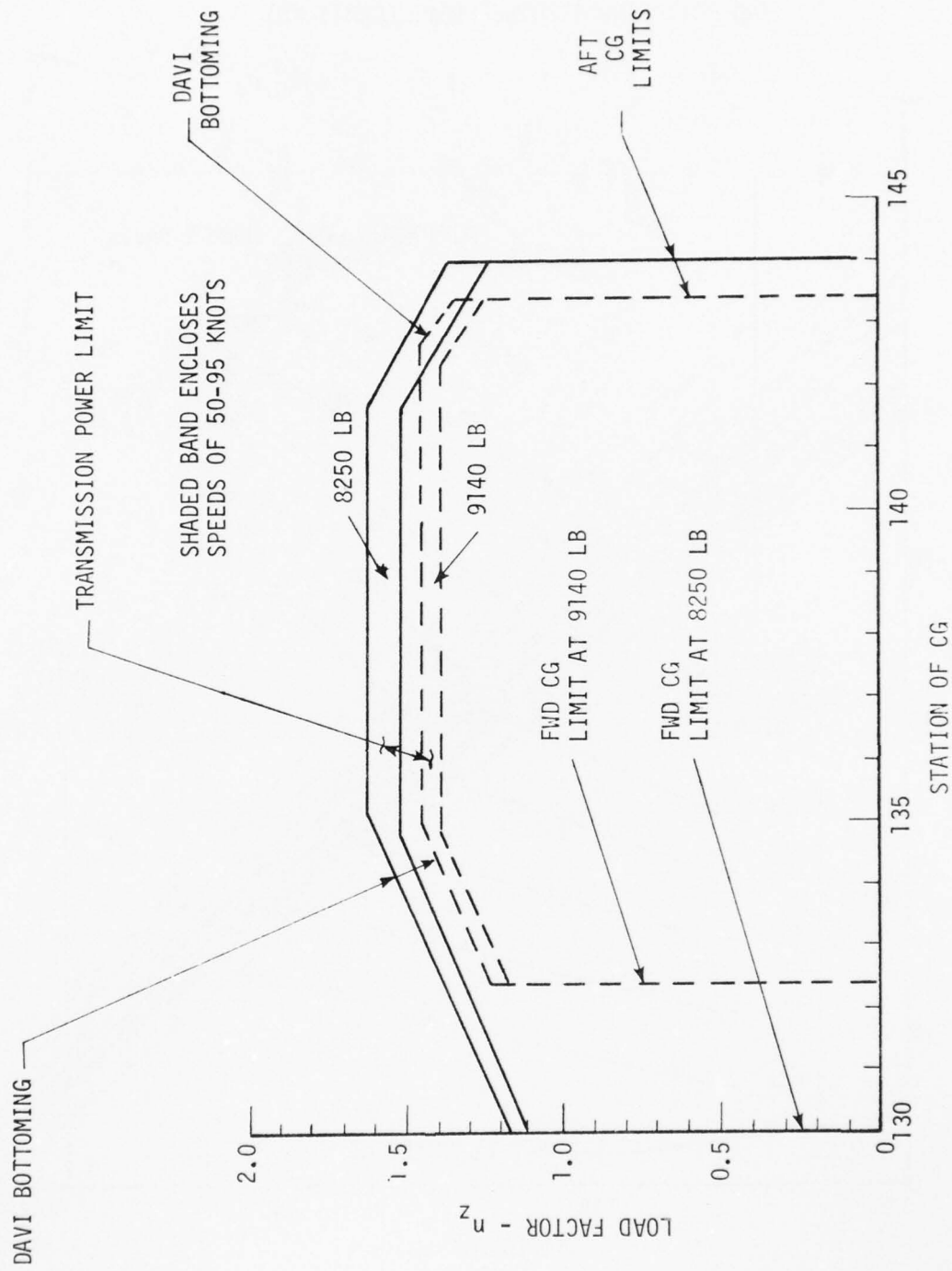

Figure 83. Constant Bank Angle Turns @ 50-95 Knots Where the Operating Envelope is Imposed by DAVI Bottoming, CG and Power Limitations (8250 and 9140 Lb)

DAVI Deflection/Coupling Misalignment

Using the flight conditions given in Figure 27, the deflections in the DAVI mounts were calculated. These deflections were calculated for the trim conditions expected in flight and were determined from the unloaded position (i.e., aircraft on the ground with zero rotor thrust). These deflections are given in Table 28.

It is seen from this table that the only significant deflection is in the vertical direction. The maximum vertical deflection obtained in flight is well within the designed bottoming limits of the DAVI.

To determine the effective misalignment of the coupling for these flight conditions, the results given in Table 28 were transformed to the coupling location and misalignment of the coupling was calculated. The calculations given in Table 29 have been corrected for the intentional misalignment of -1.98 degrees in the vertical and -.47 degree in the lateral direction.

It is seen from Table 29 that the calculated misalignment of the coupling is well within the allowable misalignment of the coupling of 2 degrees for 1100 horsepower.

TABLE 28. CALCULATED DEFLECTION OF DAVI MOUNTS

TABLE 28. CALCULATED DEFLECTION OF DAVI MOUNTS											
Condition			Deflection - Inch							Long.* Dir	Lat* Dir
			Vertical Direction					Lift Link			
			Fwd Rt	Fwd Left	Aft Rt	Aft Left	SP (kn)				
GW (lb)	SP (kn)	Fwd Rt	Fwd Left	Aft Rt	Aft Left	Lift Link	Long.* Dir	Lat* Dir			
Level Flt	8250	50	.092	.196	.199	.303	.178	.040	.034		
		65	.106	.213	.179	.285	.182	.037	.032		
		80	.098	.215	.181	.298	.182	.042	.036		
		95	.093	.233	.167	.307	.186	.049	.041		
		111	.078	.250	.191	.335	.163	.059	.051		
Turn		50	.140	.370	.204	.433	.275	.083	.071		
Turn		90	.131	.314	.178	.362	.237	.061	.052		
Level Flt	9140	0	.303	.252	.107	.158	.232	.055	.047		
		50	.108	.234	.210	.336	.203	.049	.042		
		65	.122	.252	.188	.318	.208	.050	.042		
		80	.120	.259	.186	.325	.210	.050	.043		
		95	.113	.271	.180	.338	.213	.051	.043		
	111	.103	.288	.175	.361	.218	.052	.044			
Turn		50	.146	.388	.213	.455	.288	.087	.074		
Turn		90	.148	.365	.188	.405	.269	.070	.060		

* Average absolute value of the deflection in the mounts in the longitudinal and lateral directions.

TABLE 29. CALCULATED MISALIGNMENT OF THE COUPLING

GW (lb)	Load Factor	Speed (kn)	Misalignment			
			Vertical (deg)	Lateral (deg)	Resultant (deg)	Longitudinal (in.)
9140	1.0	0	-1.598	-.265	1.620	+.086
9140	1.0	50	.077	-.231	.243	-.062
9140	1.0	65	-.165	-.205	.263	-.042
9140	1.0	80	-.138	-.216	.256	-.042
9140	1.0	95	-.115	-.289	.311	-.043
9140	1.0	111	-.039	-.378	.380	-.046
8250	1.0	50	-.038	-.068	.078	-.067
8250	1.0	65	-.273	-.063	.280	-.045
8250	1.0	80	-.185	-.12	.220	-.057
8250	1.0	95	-.172	-.226	.284	-.061
8250	1.0	111	-.120	-.381	.399	-.062
8250	1.5	50	.255	-.688	.733	-.049
8250	1.25	95	-.101	-.420	.741	-.037
9140	1.39	50	.364	-.752	.835	-.052
9140	1.25	95	.038	-.574	.575	-.031

GROUND TESTS

In order to qualify the DAVI system for flight, substantial testing of components and the complete system was done on the ground. Component testing was done early in the program to insure feasibility and confidence in the design, especially for the pivots selected for the DAVI. A component endurance test was done on a tubular mount to assist in the design of the actual lift-link DAVI. Upon fabrication of the DAVI mounts, they were tested statically to determine the spring rates of the mounts. The DAVIs were tuned individually to obtain an antiresonance at 10.8 Hertz.

The DAVI system was tested for 100 hours for endurance. The vehicle with the DAVI system was proof-tested to 1.25-limit load. Both the DAVI and the conventional systems were shake tested, and data was analyzed and compared. The same instrumentation was used where possible in the tests. Table 30 gives this instrumentation.

COMPONENT TESTS

Pivot Test

A pivot test was done to determine the feasibility and life of the spherical bearings selected for the DAVI design. Figure 84 is a photograph of the test setup. In this test, an actual inertia bar from a transmission DAVI was used to produce the appropriate loads on the isolated and non-isolated pivots. The isolated pivot was fixed to the structure of the test rig and was not permitted to translate. The non-isolated pivot was driven by an electric motor through a cam to produce a 0.1-inch translation of that pivot. The test was performed in steps so as to evaluate the fatigue strength of the inertia bar as well as to accelerate the bearing wear. Wear on the bearing was measured after 120 hours at normal load and at the termination of the test at 360 hours. The increase in pivot load was accomplished by an increase in frequency and not by an increase in inertia bar amplitude of motion. Table 31 gives the results of this test.

The bearing performed adequately at the end of the test, even though the composite liner was severely cracked, and no plastic flow or "pounding out" added to the clearance.

From the test results given in Table 31, analysis was performed to determine the wear life. For the purposes of analysis, it was assumed that the first 120 hours would represent a rapid wear-in phase and that the remaining 240 hours would represent a slower wear-out phase. In the first phase, .0014 inch of wear occurred, and in the second phase, .0028 inch of wear occurred. The life of the bearing was calculated to be 1231.4 hours.

TABLE 30. GROUND TEST INSTRUMENTATION

Accelerometers

1. Nose vertical, station 0.
2. Nose lateral, station 0.
3. Nose longitudinal, station 0.
4. Pilots area vertical, station 55.
5. Pilots area lateral, station 55.
6. Pilots area longitudinal, station 55.
7. Copilots area vertical, station 55.
8. Copilots area lateral, station 55.
9. Copilots area longitudinal, station 55.
10. Upper transmission housing vertical, station 140.
11. Upper transmission housing lateral, station 140.
12. Upper transmission housing longitudinal, station 140.
13. Center of gravity vertical, station 138.
14. Center of gravity lateral, station 138.
15. Center of gravity longitudinal, station 138.
16. Tail pylon vertical, station 485.
17. Tail pylon lateral, station 485.
18. Tail pylon longitudinal, station 485.

Linear Potentiometers

1. Left forward transmission mount vertical.
2. Left forward transmission mount longitudinal.
3. Right forward transmission mount vertical.
4. Right forward transmission mount lateral.
5. Right forward transmission mount longitudinal.
6. Left aft transmission mount vertical.
7. Left aft transmission mount lateral.
8. Left aft transmission mount longitudinal.
9. Right aft transmission mount vertical.

Transmission Case Strain Gages

- | | |
|-------------|---|
| 1. Gage 1 | Transmission support plate right aft ear. |
| 2. Gage 2 | Transmission support plate right aft ear. |
| 3. Gage 3 | Transmission support plate right aft ear. |
| 4. Gage 4 | Transmission support plate right aft ear. |
| 5. Gage 5 | Transmission support plate right aft ear. |
| 6. Gage 6 | Transmission support plate right aft ear. |
| 7. Gage 7 | Transmission support plate right forward ear. |
| 8. Gage 8 | Transmission support plate right forward ear. |
| 9. Gage 9 | Transmission support plate left forward ear. |
| 10. Gage 10 | Transmission support plate left forward ear. |
| 11. Gage 11 | Transmission support plate left aft ear. |
| 12. Gage 12 | Transmission support plate left aft ear. |

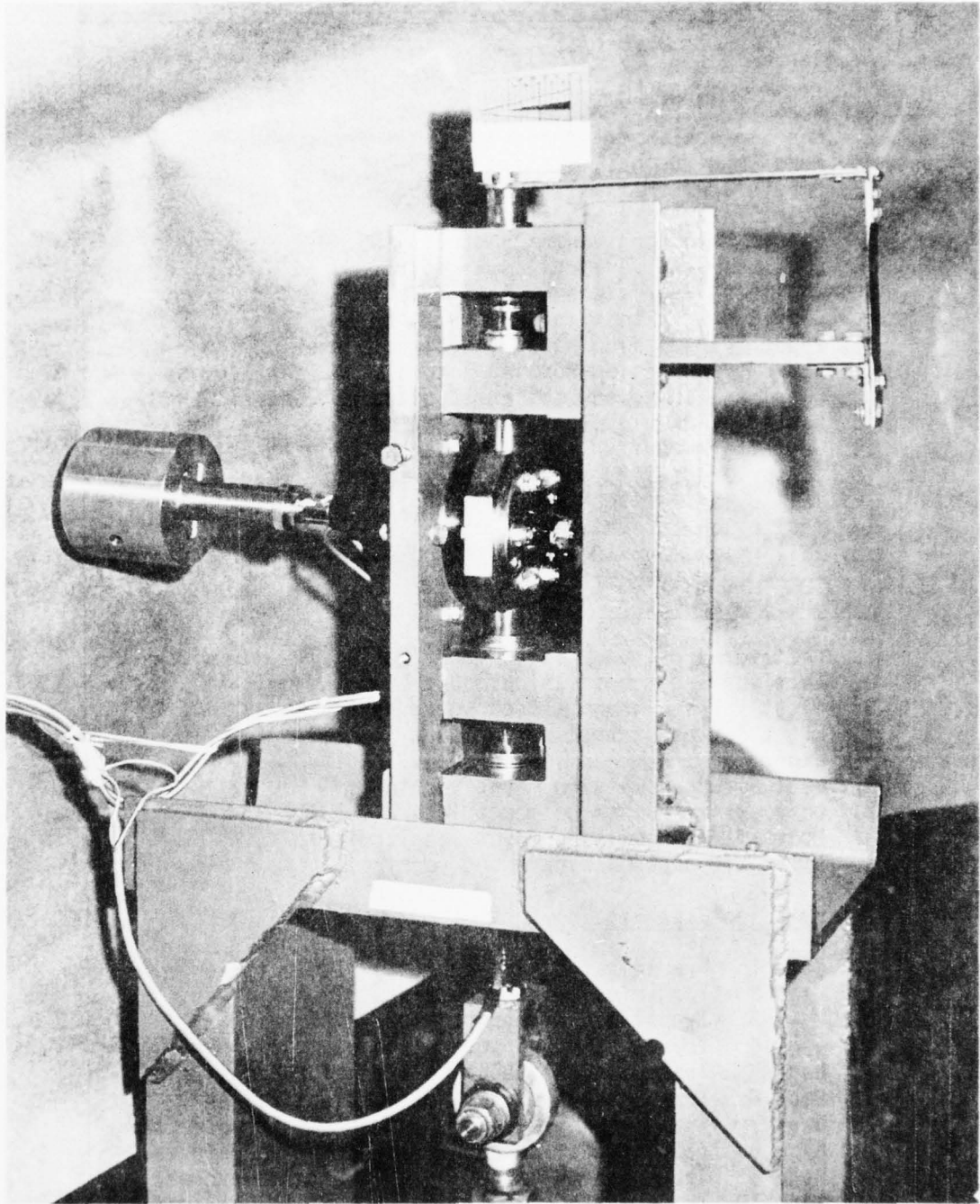

Figure 84. Pivot Test

TABLE 31. PIVOT TEST

Time (hr)	Frequency (Hz)	Amplitude (in.)	Cycles x 10 ⁶	Test Load (\pm lb)	Measured Wear (in.)
120.0	9.0	.1	3.888	618	.0014
150.9	9.0	.1	1.0	615	Not Meas
178.8	9.95	.1	.999	745	"
205.3	10.5	.1	1.001	855	"
230.6	10.95	.1	.997	1020	"
254.6	11.44	.1	.998	1180	"
279.5	11.69	.1	1.048	1350	"
333.4	11.89	.1	2.307	1265	"
360.0	12.09	.1	1.158	1287	.0042

Lift-Link Tubular Mount

A simulated lift-link DAVI natural rubber mount was fabricated and vulcanized at Kaman Aerospace Corporation. Testing was done on the same rig (Figure 84) as the pivot test. Testing was conducted at the two-per-rev frequency (10.8 Hertz) with an input load of +875 pounds at an amplitude of \pm .075 inch for 98.2 hours. Upon completion of this test, visual inspection showed no deterioration of the rubber. Final qualification of the mount, including inertia bars, was done in the 100-hour endurance test of the complete isolation system.

DAVI Tuning and Spring Rate Tests

Two UH-1 lift-link DAVIs and nine transmission-mount DAVIs were tested to determine their static spring rates and to tune each of the mounts to an antiresonance frequency of 10.8 Hertz. Static load versus deflection was measured for each mount. The basic static spring rate was obtained by applying loads from 0 to 3000 pounds for the lift-link DAVI and from 0 to 1500 pounds for the transmission DAVI. An effective dynamic spring rate (more representative of flight conditions) was obtained by preloading the mount to a representative steady load and very slowly applying representative cyclic flight loads. The results of these tests for the mounts selected for the UH-1 helicopter are given in Table 32.

TABLE 32. AVERAGE DAVI SPRING RATES

Mount	Direction	Static Spring Rate (lb/in.)	Dynamic Spring Rate		
			Preload (lb)	Cyclic Ld (lb)	Spring Rate (lb/in.)
Transmission	Vertical	6774	500	+100	7938
				+200	7621
				+300	7394
				+400	7164
Longitudinal	Lateral	6246			
		44100			
Lift Link	Vertical	6900	1000	+120	8200
				+240	7800
				+360	7600
			2000	+120	7900
				+240	7600
				+360	7350
System	Vertical*	33996	Dynamic Spring Rate - lb/in.		
			Minimum	Maximum	
	Longitudinal	24984	34810	39952	
	Lateral	176400	-	-	

* Static Spring Rate - (4)(6774) + 6900 = 33996 lb/in.
 Minimum Dynamic Spring Rate - (4)(6865) + 7350 = 34810 lb/in.
 Maximum Dynamic Spring Rate - (4)(7938) + 8200 = 39952 lb/in.

From Table 32 it is seen that, with the use of elastomeric springs, a variation in spring rate is obtained depending upon the static load and the magnitude of the vibratory load. The static spring rate of the transmission mount is 4.2 percent higher than the design goal of 6500 lb/in., and the DAVI lift link is 31 percent softer than the design goal of 10,000 lb/in. However, the system total static vertical spring rate is only 5.5 percent softer than the design goal of 36,000 lb/in. Further, using the maximum dynamic spring rate obtained in the testing, the DAVI transmission mount is 22.1 percent stiffer than the design goal of 6500 lb/in., and the DAVI lift link is 18 percent softer than the design goal of 10,000, but the system vertical spring rate is 11.0 percent stiffer than the design goal of 36,000 lb/in. Using the softest dynamic spring rate obtained in the test, the DAVI transmission mount is 5.8 percent stiffer than the design goal of 6500 lb/in., and the DAVI lift link is 26.5 percent softer than the design goal of 10,000 lb/in. However, the system vertical spring rate is only 3.3 percent softer than the design goal of 36,000 lb/in.

A similar static test was done on a standard mount used in the UH-1H helicopter; Table 33 gives the results of this test. This test was done in the vertical (shear) direction only.

TABLE 33. STANDARD MOUNT SPRING RATES			
Static Spring Rate (lb/in.)	Dynamic Spring Rate		
	Preload (lb)	Cyclic Load (lb)	Spring Rate (lb/in.)
4060	300	+100	5422
		+200	4813
4060	500	+100	5112
		+200	4737
		+300	4433
		+400	4285

It is seen from Table 33 that a variation of spring rate is obtained that depends upon the static load and the magnitude of the vibratory load. The static spring rate of this standard mount is 9.0 percent softer than the reported design spring rate of 4500 lb/in. The maximum dynamic spring rate is 20.4 percent stiffer than the desired spring rate of 4500 lb/in., and the minimum dynamic spring rate is 4.8 percent softer than the desired spring rate of 4500 lb/in. Based upon the measured static spring rate, the maximum dynamic spring rate is 33.5 percent stiffer; whereas, in the DAVI system, the maximum dynamic spring rate is 17.2 percent stiffer than the measured static spring rate.

Because of the variation in spring rate, all of the DAVI units were individually tuned as functions of the vibratory load. Figure 85 is a photograph of the tuning rig. For the tuning tests, the data acquisition and recording system included: a force gage between the output (isolated plate) of the DAVI and the stiff test rig for measuring output force; a potentiometer between the input (nonisolated housing) and the output (isolated plate) of the DAVI to measure deflection; an accelerometer on the nonisolated housing of the DAVI for measuring input accelerations; a force gage between the shaker and the nonisolated housing of the DAVI to measure input force; signal conditioners for force, displacement and acceleration signal amplification; Spectral Dynamics SD 1002E Automatic Mechanical Impedance System to process the data; and a Hewlett Packard Analog Recorder to record the data. The force excitation system consisted of an MB Electronics 500-pound capacity electromagnetic exciter and power amplifier system.

The procedure for tuning a DAVI was to obtain the in-phase component of the ratio of the output force to the displacement (displacement impedance) and/or the acceleration (acceleration impedance) for a sweep frequency from 5 to 15 Hertz, and then to move the inertia weight so that the impedance would be zero at 10.8 Hertz, i.e., the output force of the DAVI would be zero. Table 34 shows the results of these tuning tests for the DAVI mounts on the UH-1H helicopter.

It is seen from Table 34 that, as in the static spring rate tests, the tuning is a function of vibratory load. The DAVIs were tuned to 10.8 Hertz for the mid-vibratory force range, giving less than a 2-percent variation in tuning for the magnitude of vibratory force expected.

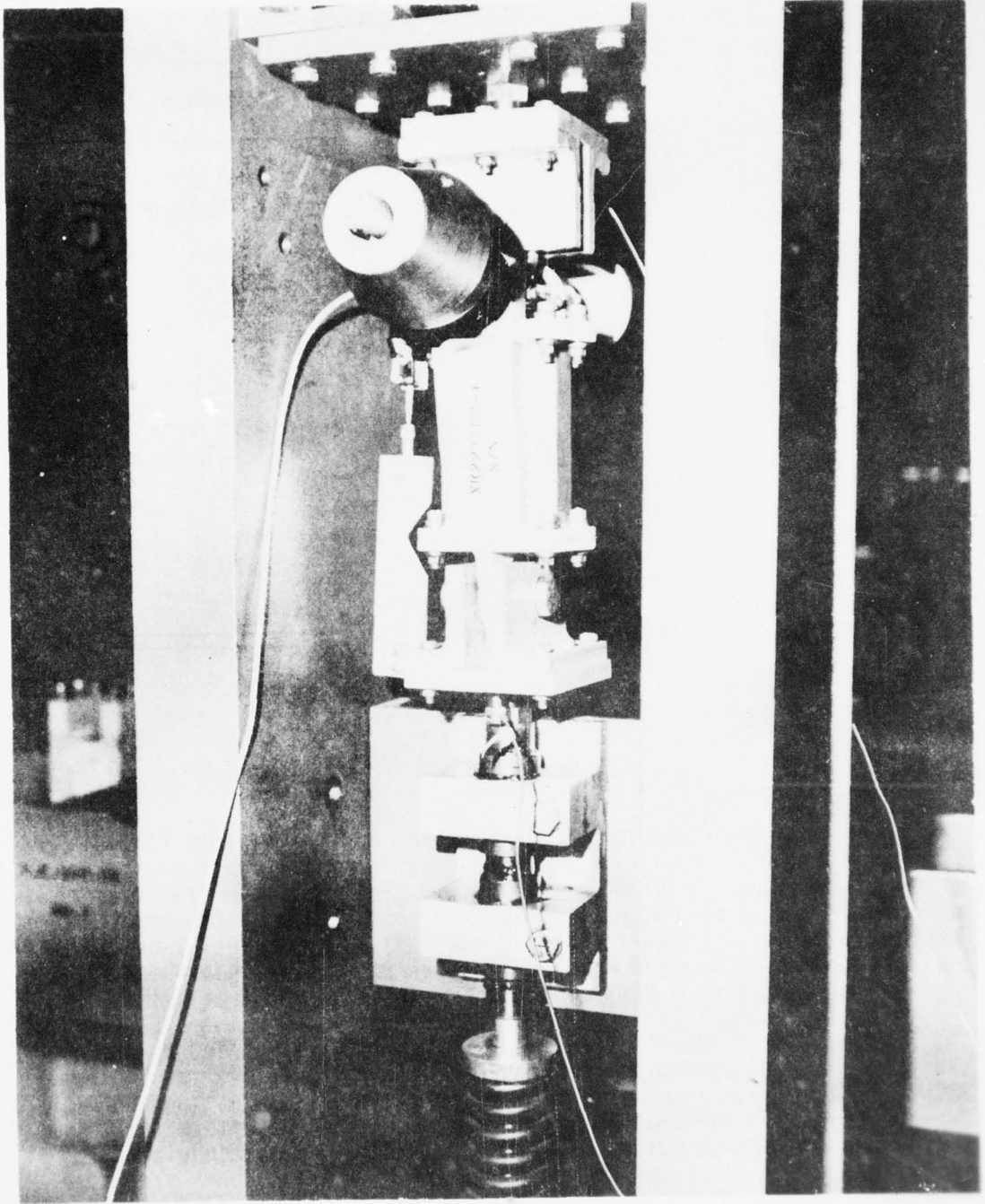

Figure 85. DAVI Tuning Rig

AD-A051 319

KAMAN AEROSPACE CORP BLOOMFIELD CONN
ADVANCED DEVELOPMENT OF A HELICOPTER ROTOR ISOLATION SYSTEM FOR--ETC(U)
DEC 77 R JONES DAAJ02-72-C-0082
R-1396-2 USAAMRDL-TR-77-238 NL

UNCLASSIFIED

3 OF 3
AD A051 319



END
DATE
FILMED
4-78
DDC



TABLE 34. DAVI TUNING

DAVI	Vibratory Force (lb)	Antiresonant Freq (Hz)
Trans #1	+100	11.0
	<u>+200</u>	10.8
Trans #2	+100	11.0
	<u>+200</u>	10.8
	<u>+300</u>	10.7
Trans #5	<u>+200</u>	10.6
	<u>+300</u>	10.2
Trans #9	+100	11.0
	<u>+200</u>	10.8
	<u>+300</u>	10.5
Lift Link #2	+120	11.0
	<u>+240</u>	10.8
	<u>+320</u>	10.6

SYSTEM TESTSEndurance TestTest Configuration

A 100-hour endurance test was conducted on the complete DAVI isolation system. Figures 86 and 87 show a schematic and a photograph of the test setup. As seen in the figures, a scrap UH-1H transmission and shaft and a dummy rotor assembly were installed with the complete DAVI isolation system and friction dampers on a rigid steel I-beam structure representing the fuselage. The transmission and I-beam structure was suspended on a soft bungee to simulate a free-free system.

The steady state 1g level-flight inplane forces were applied to the hub via loaded trays suspended by soft bungee and pulleys, and the 1g level-flight vertical force was achieved by appropriately ballasting the I-beam structure representing the fuselage. The steady-state torque was applied to the transmission case rather than the hub to minimize the restraint of the rotor and shaft. These forces on the lower structure (fuselage) were reacted by soft bungee attached to a fixed structure of the test bay area. Vertical, longitudinal and lateral vibratory forces

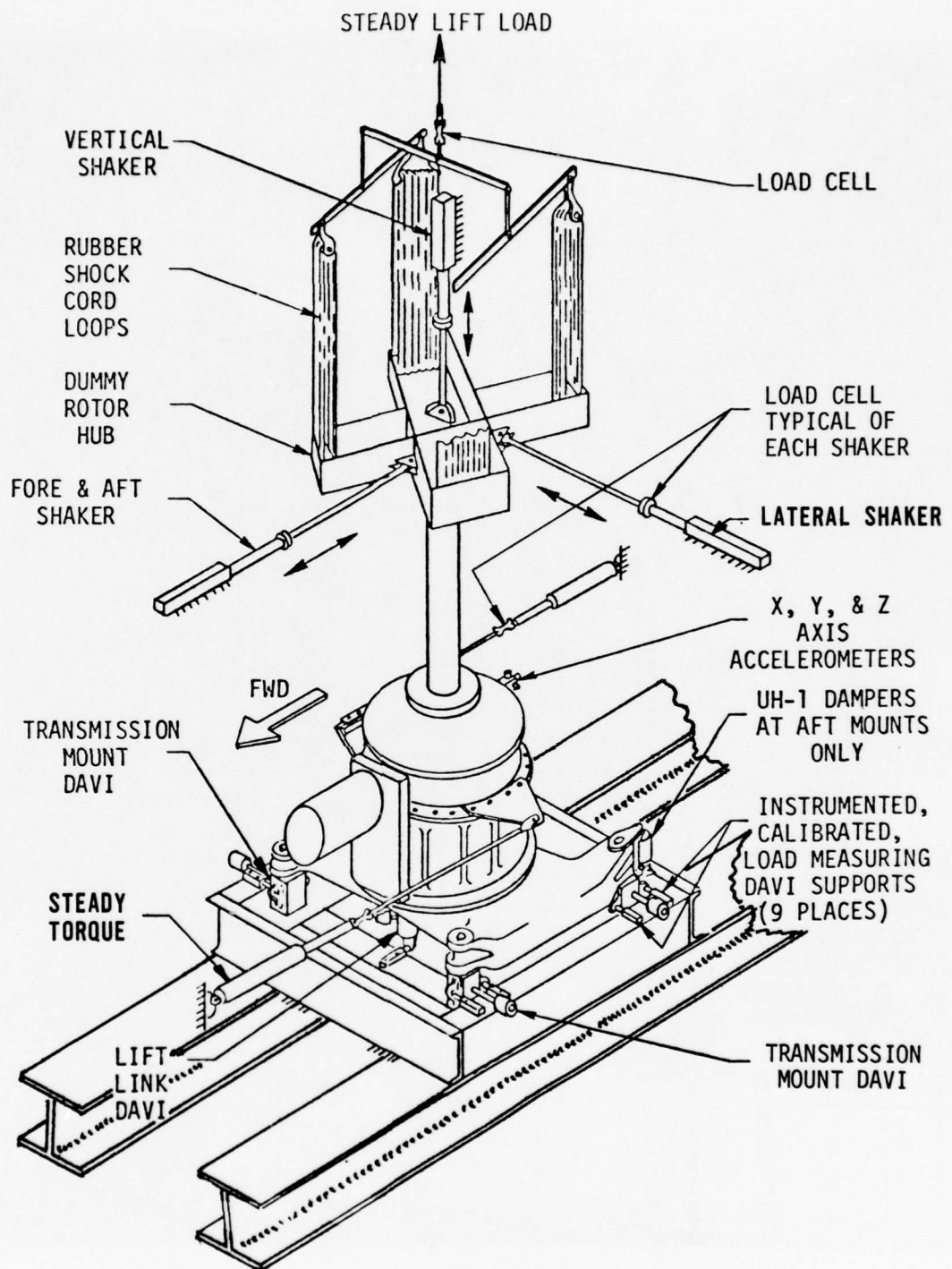

Figure 86. Schematic of Endurance Test Rig

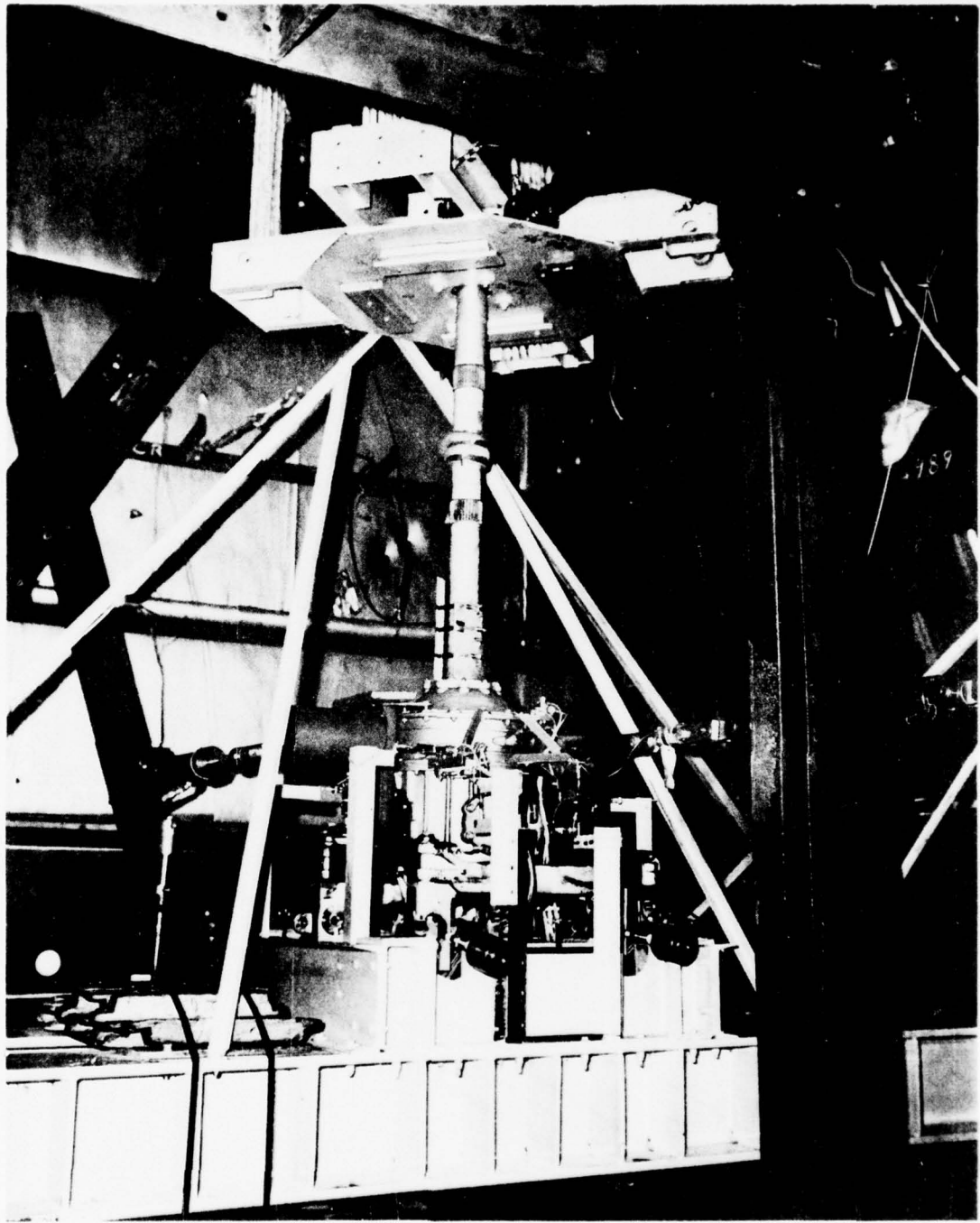

Figure 87. Endurance Rig

were applied at the hub by hydraulic shakers. The complete results of this test are given in Reference 19.

Test Conditions

This endurance test represented the high-speed flight condition of 116 knots for a 8250-pound UH-1H helicopter.

Table 35 gives the steady-state forces calculated for this flight condition. These forces are in the rotor mast reference axes.

TABLE 35. ROTOR TRIM FORCES		
Force/Moment	Magnitude	Direction
Longitudinal	20 lb	Positive Forward
Lateral	168 lb	Positive Left Looking Forward
Vertical	8900 lb	Positive Up
Torque	185,000 in.-lb	Positive Clockwise Looking Down

For the 8250-pound UH-1H helicopter, the expected hub vibratory forces at 116 knots are:

$$\begin{aligned}\text{Vertical Force} &= \underline{+990} \text{ lb} \\ \text{Longitudinal Force} &= \underline{+1650} \text{ lb} \\ \text{Lateral Force} &= \underline{+1525} \text{ lb}\end{aligned}$$

¹⁹ Luff, TEST RESULTS, FATIGUE TEST OF DAVI ROTOR ISOLATION MOUNTS FOR THE ARMY MODEL UH-1H HELICOPTER, Kaman Aerospace Corporation, Bloomfield, CT, Kaman Report T-585-1, August 1975.

It is these forces that were used for the basis of the endurance test. In order to determine the load factor to be used in this 100-hour test, an analysis was done: In this test, the total number of test cycles is 3.89×10^6 . Assuming that the test specimen is representative of those of mean strength and that the desired probability level for no failure is 0.9987 (for a +3 standard deviation from the mean where the fatigue strength at a specific fatigue life follows a normal distribution), and using the test point as a fatigue failure at 3.89×10^6 cycles, then

$$3\sigma = \bar{x} - x \quad (2)$$

where \bar{x} is the test load and x is the actual load.

For a test load of 1.5 times the actual load, then $x = 2/3 \bar{x}$ and

$$3\sigma = \bar{x}/3 \quad (3)$$

Since the coefficient of variation $C_v = \sigma/\bar{x}$, then $C_v = 1/9$.

The coefficient of variation is 11.1 percent. Fatigue-test experience at Kaman indicates that typical machined parts assemblies, such as the DAVI units, designed for fatigue give coefficients of variation of 10 percent. Thus, it was reasoned that a single test for 100 hours at 1.5 times the actual vibratory loads should be sufficient to assure that there will be no fatigue failure during the 20-hour flight test phase.

Other factors that contribute to the safety of flight conclusion are:

1. The test condition (116-knot trimmed-level flight at 8250 pounds) duplicates the flight vibratory hub loads for the critical vibratory flight condition to be flown during the 20 total hours of flight testing. It is envisioned that less than one hour will be spent in this condition.
2. The test conservatively put all the vibratory hub loads in phase - actual loads are not.

Therefore, for this endurance test, the following forces were applied at 10.8 Hertz (two-per-rev forcing frequency):

Vertical Force	=	<u>+1500</u> lb
Longitudinal Force	=	<u>+2475</u> lb
Lateral Force	=	<u>+2288</u> lb

During the first 28.2 hours of testing, the vertical force being applied by the shaker was harmonically analyzed. This analysis showed that, although the two-per-rev force was the predominant level, other higher harmonic force levels were being put into the structure. For a fatigue test, it is sufficient to insure that the peak-to-peak value at the desired frequency be maintained to obtain valid results. To be conservative and to ensure a higher two-per-rev force level, the vertical force was increased to ± 1800 lb and maintained throughout the remainder of the test.

Instrumentation

Instrumentation used in this test included the linear potentiometers, transmission case strain gages, and the upper transmission housing vertical, lateral, and longitudinal accelerometers given in Table 30. Additional instrumentation included three strain gage load cells between the hydraulic shakers and the hub attachment to measure the vertical, longitudinal and lateral vibratory force inputs. The vertical forces transmitted to the isolated I-beam structure were measured by gaged, calibrated, cantilever beams from the I-beams which support the DAVI isolators at the lugs through which they normally attach to the fuselage (see Figure 86) and by calibrated strain gages at the attachment of the friction dampers. Three vertical accelerometers were used on the I-beam structure, two located near the aft DAVI attachments and one located on the center line of the aft end of the I-beam structure.

Test Results

Data from the nine potentiometers were harmonically analyzed to determine the two-per-rev relative motion between the upper and lower bodies. These relative motions were obtained at the centroid of the potentiometers, which is 11.5 inches above the isolation system mounting (point "A" on Figure 44). Table 36 gives the results of the relative vibratory motion.

TABLE 36. ENDURANCE RIG TWO-PER-REV RELATIVE MOTIONS	
Direction	Magnitude
Vertical Translation	$\pm .0447$ inch
Longitudinal Translation	$\pm .06602$ inch
Lateral Translation	$\pm .0058$ inch
Angular Pitching	$\pm .248$ degree
Angular Rolling	$\pm .022$ degree
Angular Yawing	$\pm .011$ degree

It is seen from Table 36 that the vibratory relative deflections for all six directions are small. However, to determine the magnitude of the vibratory misalignment of the engine driveshaft, these motions were transformed to the engine drive coupling location on the transmission. Table 37 gives the results of this transformation.

TABLE 37. ENDURANCE RIG TWO-PER-REV VIBRATORY MISALIGNMENT OF THE ENGINE DRIVE COUPLING	
Direction	Magnitude
Vertical Translation and Pitching	$\pm .319$ degree
Lateral Translation and Yawing	$\pm .033$ degree
Resultant	$\pm .321$ degree
Longitudinal Translation	$\pm .041$ inch

It is seen from Table 37 that the apparent vibratory misalignment is small for the high vibratory load at the hub in this test.

Upon completion of the 100-hour endurance test, the critical parts of the DAVI mounts were inspected. All six inertia bars (four transmission-mount DAVI bars and two lift-link DAVI bars) were magnetic-particle inspected. Only one bar was found to have a crack indication. This was in the right-hand bar of the lift-link DAVI, in an area 2.45 inches from the tip where material had been machined out, prior to final assembly, to remove galled material which had been caused by the overlying sleeve being too tightly fitted during preliminary assembly.

All ten DAVI bearings were inspected and found to be in good condition with minimal signs of wear. The bearings had been lubricated once just prior to the 100-hour test by squirting them with a Teflon aqueous dispersion solution prepared by Kamatics.

The lift-link monoball bearing, which is a similar UH-1H part, which attaches the lift link to the main transmission and to the fuselage structure, was fretted. Fretting debris was noted in these bearings during the test. At the completion of the 100 hours, considerable effort was required to move the ball of the lower bearing. However, there was no indication of a failure of the ball.

The fretting of the subject bearing is typical of that noted in similar bearing tests of bearings operated at high loads for long periods of time. Further, if a similar type of test was made on a standard system, since no vertical isolation is achieved, the lift-link monoball would feel even higher vibratory loads.

Many small cracks and one long crack in the top outboard side of the left-hand forward DAVI elastomer were noted during and after the test. None of these cracks appeared to be very deep, and none appeared to propagate during the test. The lift-link elastomer was difficult to inspect, but the small part that could be seen appeared to be in good condition.

However, to determine whether these cracks affected the performance of the DAVIs, the two front DAVIs and the lift-link DAVI were checked for static vertical spring rates. The spring rates were determined to be very close to the spring rates recorded prior to the 100-hour test. Table 38 gives the results of the spring rate tests.

TABLE 38. COMPARATIVE DAVI SPRING RATE		
DAVI	Spring Rate Prior to Test	Spring Rate After 100 Hr Test
Right Forward Trans Mount DAVI	6563 lb/in.	6445 lb/in.
Left Forward Trans Mount DAVI	6510 lb/in.	6625 lb/in.
Lift-Link DAVI	7143 lb/in.	7090 lb/in.

The four transmission-mount DAVI spindles, which go through the transmission lugs, were DYE-CHEK'ed, and no crack indications were found. The results of the inspection showed that the DAVI system completed the 100-hour endurance test in good condition.

Proof Test

DAVI Installation Proof Load Test

Test Conditions - The test condition for the DAVI installation proof load test was based on a 45-degree banked turn at 50 knots airspeed (1.429 g normal load factor). The helicopter gross weight during that maneuver was 9142 pounds, with the center of gravity at fuselage station 137.0 and waterline 61.0. This low-speed, high-bank angle turn is the most critical flight condition to be encountered in the flight test program because, to maintain altitude for this type of maneuver, the

larger the bank angle the larger the helicopter vertical load (n_z). All other flight conditions are less severe.

Calculated flight loads for the test condition are shown in Figure 88. The test loading was designed to match the fuselage vertical shear and bending moment distributions as closely as possible in the centerbody area where the DAVIs are installed.

The proof load test was conducted to 125 percent of the limit loads shown. This overload was selected as being sufficiently high to ensure an adequate margin over the most severe flight-test condition anticipated without placing undue loads on structural areas that were not modified.

Test Setup - The test specimen used for this static proof load test is the same Army UH-1H helicopter, Serial No. 66-1093, which was used for all other phases of this program requiring the full-scale vehicle. For this test, the helicopter structural modifications and flight-control system modifications were complete, and the DAVI system that would be used for flight had been installed.

A dummy rotor hub was installed on the rotor mast. With calibrated load measuring links in the main rotor suspension, ballast was loaded into the helicopter. Using a ballast distribution as close as possible to that used during the baseline flight survey from which the test condition is derived, the weight measured 9135 pounds with the center-of-gravity at fuselage station 136.9. This was considered to be close enough to the desired condition of 9142 pounds at Station 137.

The specified forces were applied to the dummy rotor hub and to the airframe through a statically determined system of linkages consisting for the most part of steel straps connected to hydraulic actuators or steel cables connected to load trays. Figure 89 shows the system schematically, while Figure 90 is a photograph of the test setup. The applied forces were reacted against the structural test frame in which the helicopter was suspended.

Instrumentation - The instrumentation for the DAVI proof load test consisted of linear potentiometers and transmission case strain gages, as given in Table 30. Additional instrumentation included single and rosette-type strain gages on the fuselage structure in the main transmission support area. Figure 91 shows these locations. Also, four calibrated load measuring links were utilized in the loading apparatus, as shown in Figure 89, to measure applied loads.

Test Procedure - The proof load test was conducted by applying forces in incremental steps from an initial loading point. At each increment, the helicopter was in equilibrium and a set of instrumentation readings was taken. No problems were observed or indicated by the instrumentation, so the test progressed smoothly up to the maximum proof loading, which was 125 percent of limit load. Unloading was accomplished

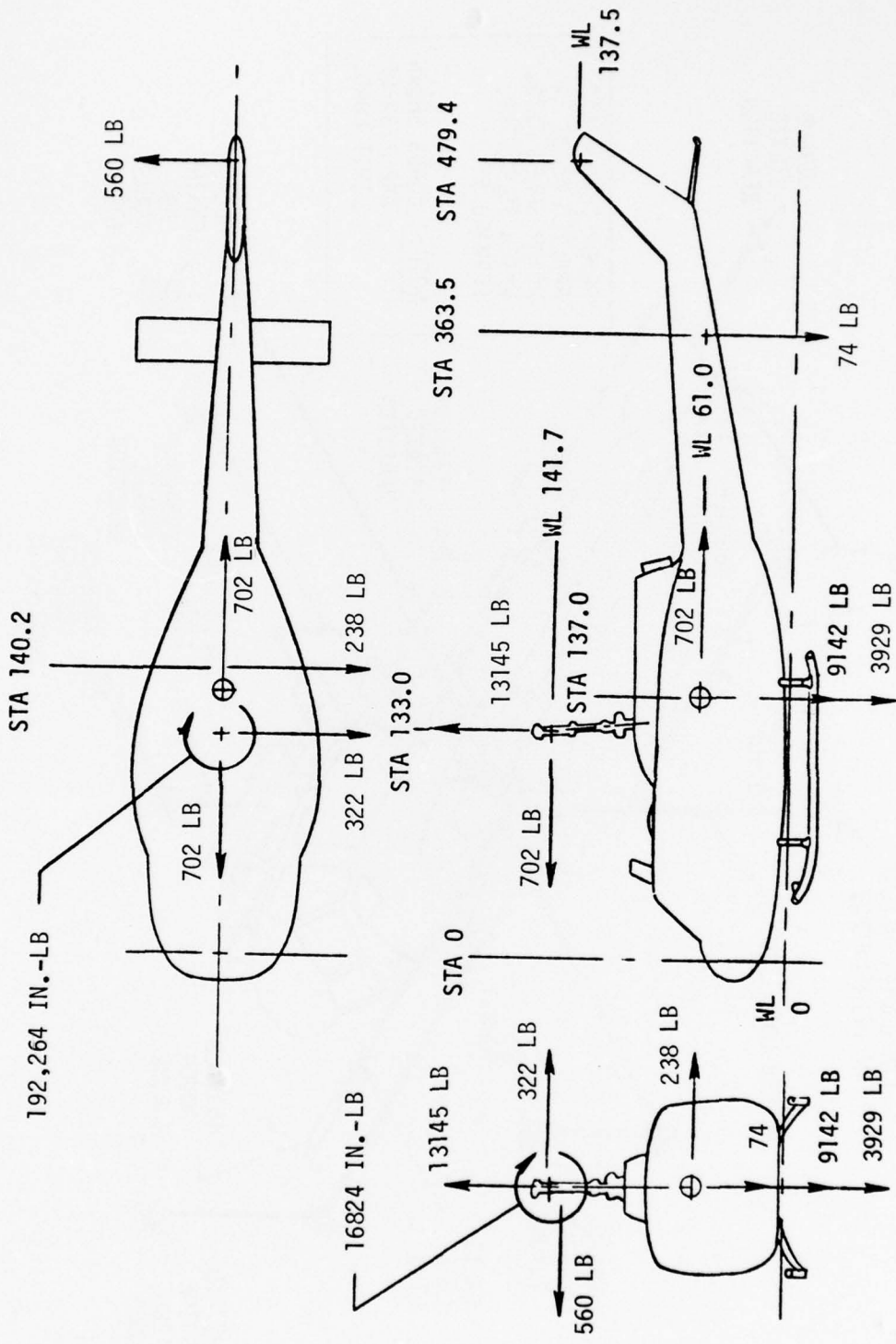

Figure 88. Load Vectors for 100 Percent of the Limit Load

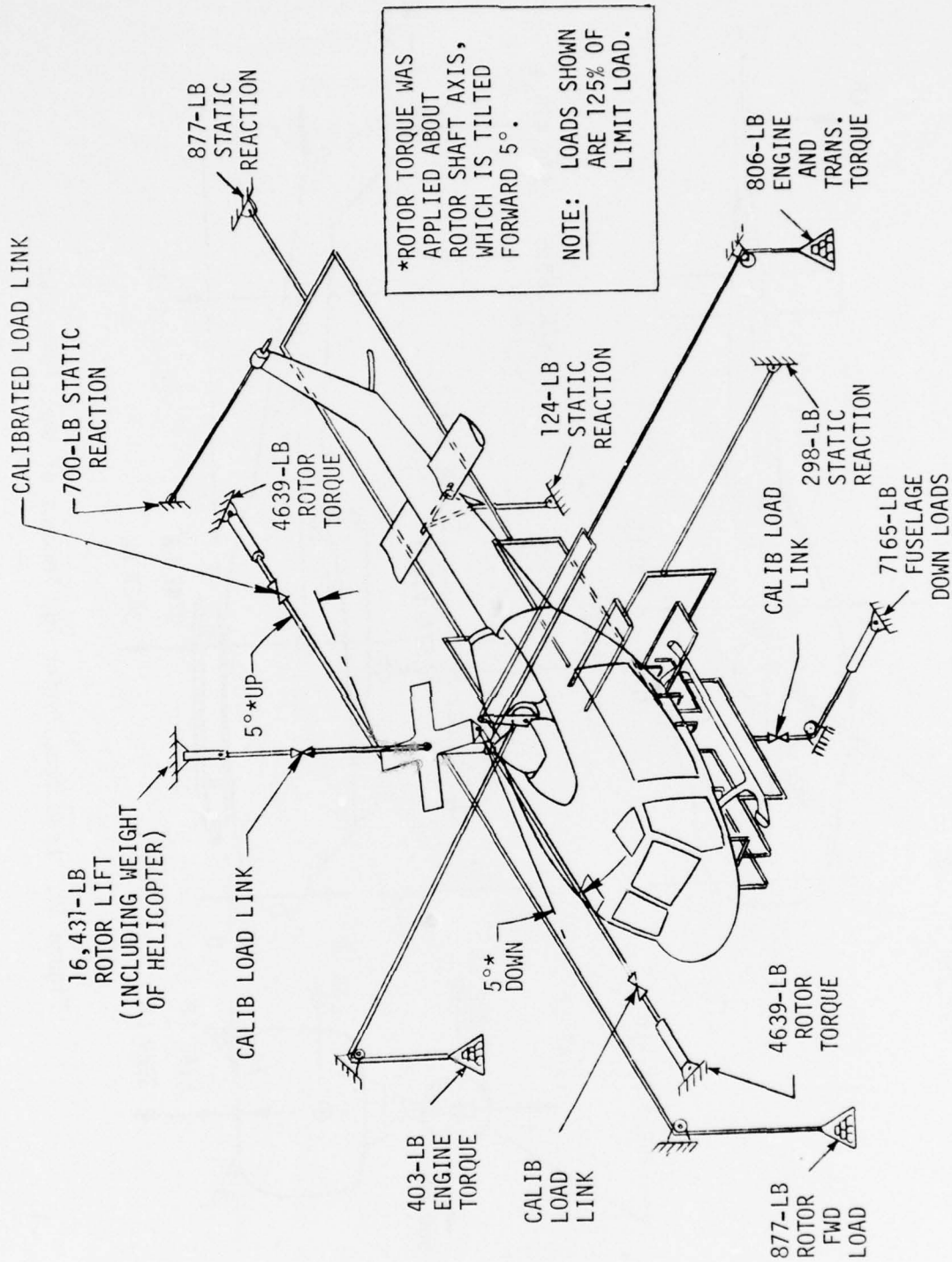

Figure 89. Schematic Diagram of Proof-Load Test

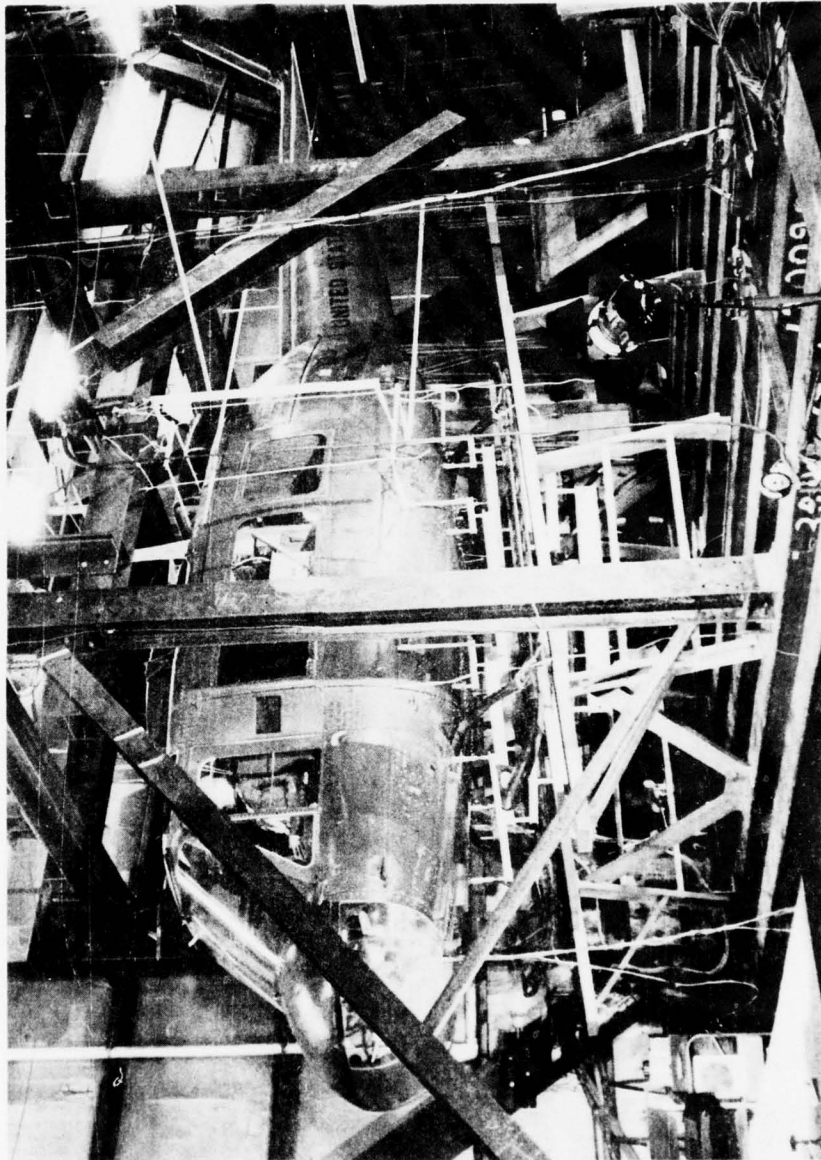
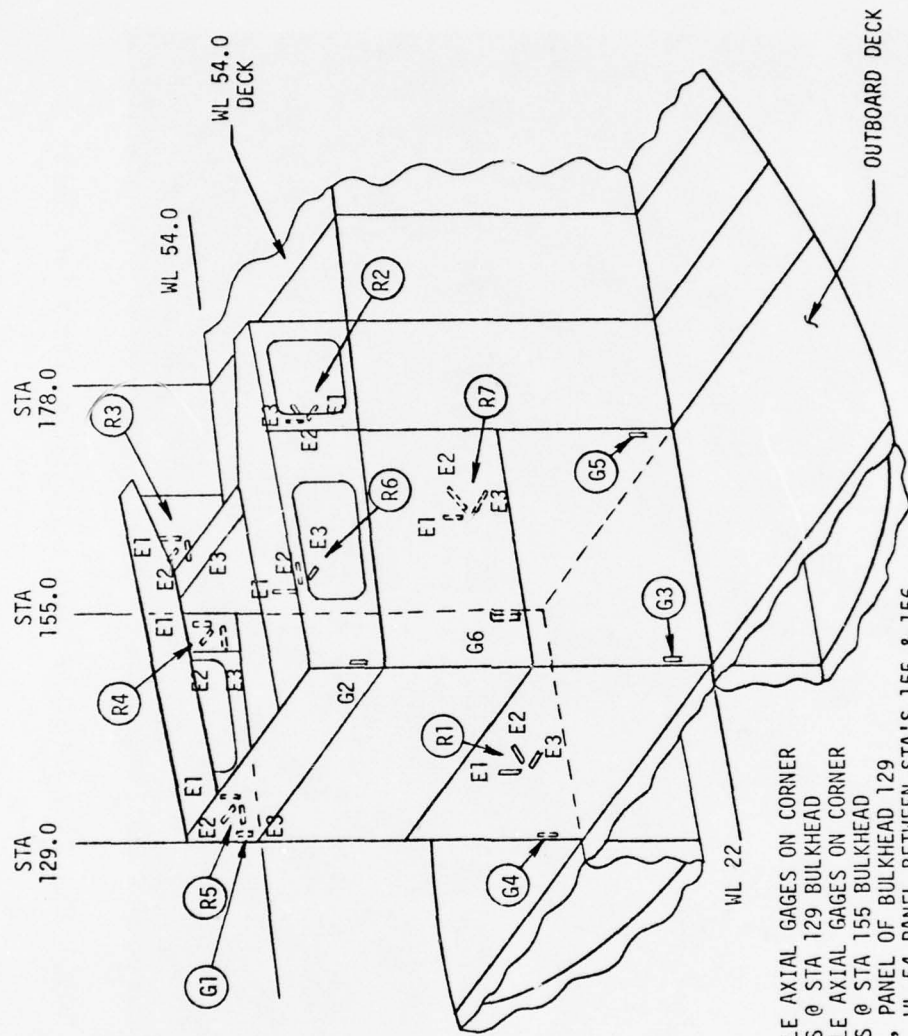

Figure 90. Test Setup for DAVI Installation Proof Load Test



- G1-G4: SINGLE AXIAL GAGES ON CORNER POSTS @ STA 129 BULKHEAD
- G5-G6: SINGLE AXIAL GAGES ON CORNER POSTS @ STA 155 BULKHEAD
- R1: ROSETTE, PANEL OF BULKHEAD 129
- R2: ROSETTE, WL 54 PANEL BETWEEN STA'S 155 & 156
- R3: ROSETTE, STRUCTURAL DOOR BETWEEN STA'S 155 & 156
- R4: ROSETTE, SIDE SKIN PANEL ABOVE WL 54, JUST FWD OF STA 155
- R5: ROSETTE, SIDE SKIN PANEL ABOVE WL 54, JUST AFT OF STA 12.9
- R6 & R7: BULKHEAD PANELS STA 159

Figure 91. Mid-Section Structure Location of Strain Gages for Proof Load Test

in the same increments of load as the loading, but instrumentation readings were taken only at 100 percent and at 70 percent of the limit load. The initial loading point, which was the baseline reference for all measurements during the test, was 70 percent of limit load. This is derived from the fact that the helicopter was ballasted to approximately 9142 pounds, which is 70 percent of the limit vertical-inertia load acting on the helicopter during the test condition maneuver.

Figure 92 shows the helicopter at 70 percent of the initial load, where the first set of instrumentation readings were taken, and Figure 93 shows the helicopter at 125 percent of the limit load.

Test Results - Figures 94, 95 and 96 show results typical of the strains and stresses obtained on the transmission support case and on the structure supporting the transmission in this proof test. It is seen from these low strains and stresses and from visual inspection of the structural panels, which showed no yielding, that the DAVI-modified helicopter withstood the application of the proof load (125 percent of limit load) without failure or permanent set.

Modified Flight Controls Proof Load Test

Test Condition - The loading conditions for the proof load test of the modified control system were the same as those used for the original control system.

The systems tested to 100-percent jam loads were the longitudinal-cyclic and the collective systems. A test of the lateral-cyclic system was not required since lateral-cyclic jam loads do not produce loads in the changed parts of the control system as large as those produced by longitudinal-cyclic jam loads.

Each system being tested was jammed, or locked against movement, as follows: the longitudinal-cyclic system was jammed at the swashplate, and the collective system was jammed at the "A" frame. The swashplate and the "A" frame were not installed on the helicopter, but instead, substitute fixtures, as shown in Figure 97, were installed to hold the control rods in the required position and to react the system-applied loads to the dummy rotor hub on the rotor mast. With the system thus jammed, the specified loads were applied to the control sticks in the cockpit. Each system was tested separately.

One-hundred-and-fifty-pound loads (.75 x 200 pounds) were simultaneously applied at the center of each longitudinal control stick handgrip, perpendicular to the centerline of the straight portion of the stick, and in a butt-line plane. The loads were applied in an aft direction starting with the sticks against the forward stops.

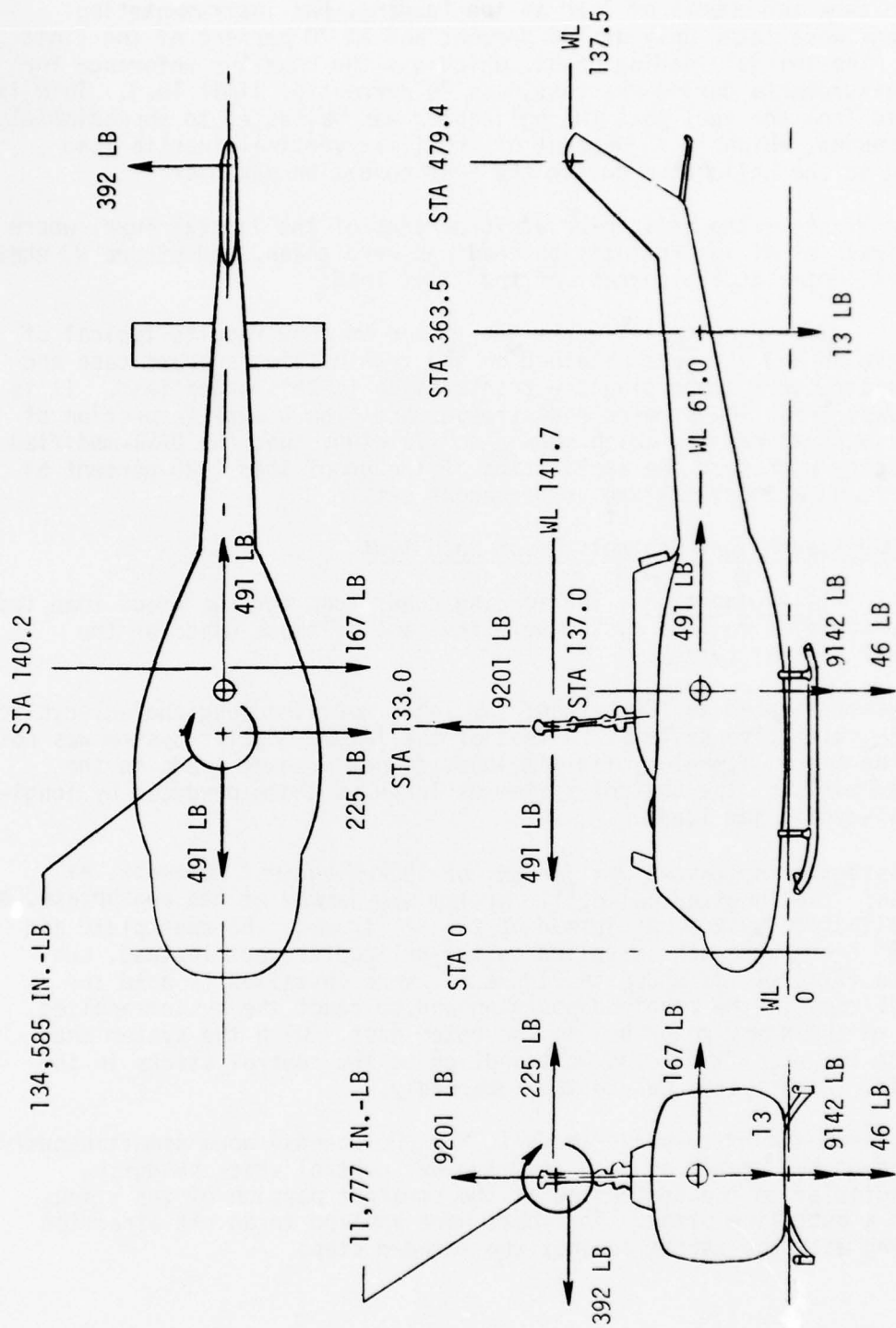

Figure 92. Load Vectors for 70 Percent of the Limit Load

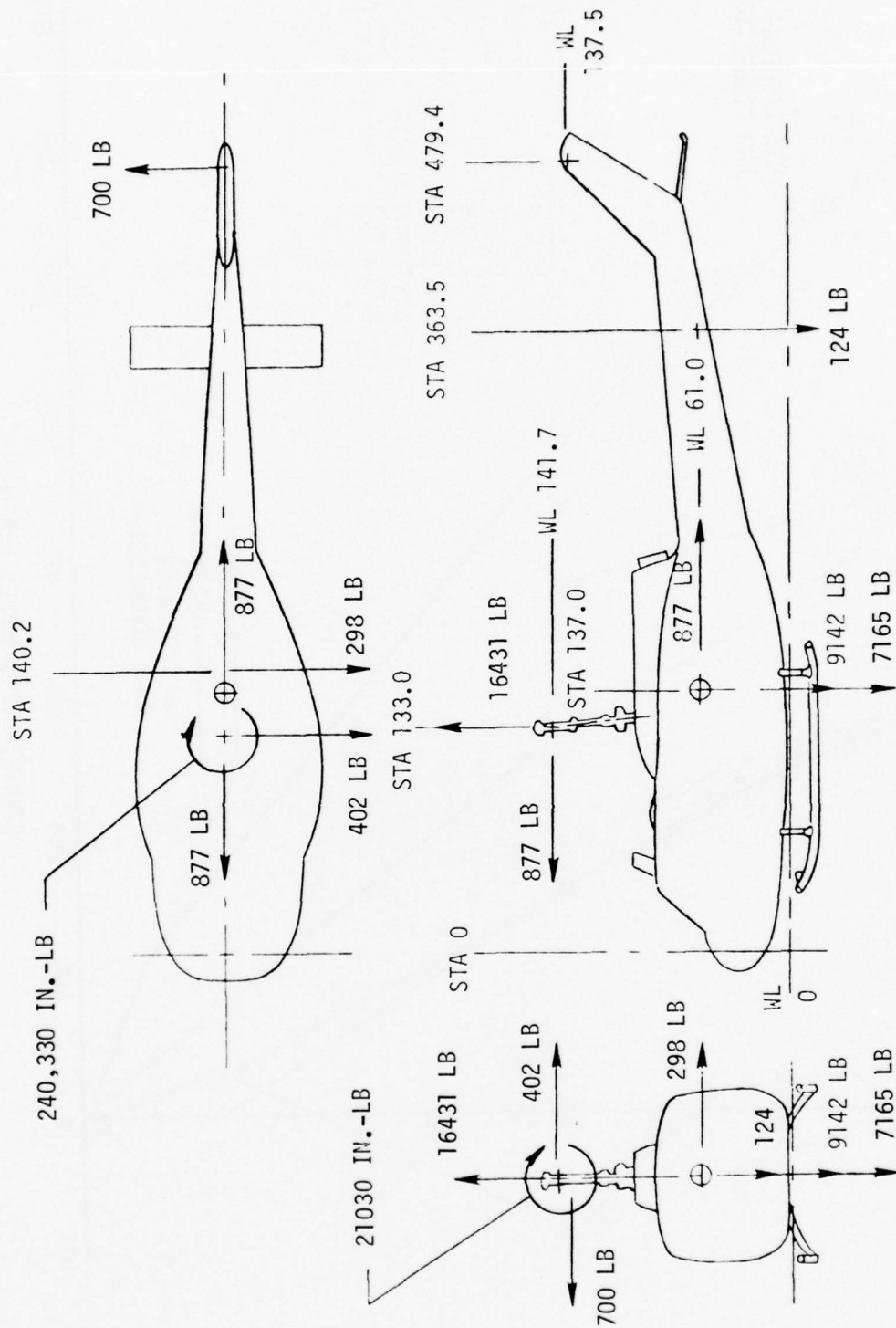

Figure 93. Load Vectors for 125 Percent of the Limit Load

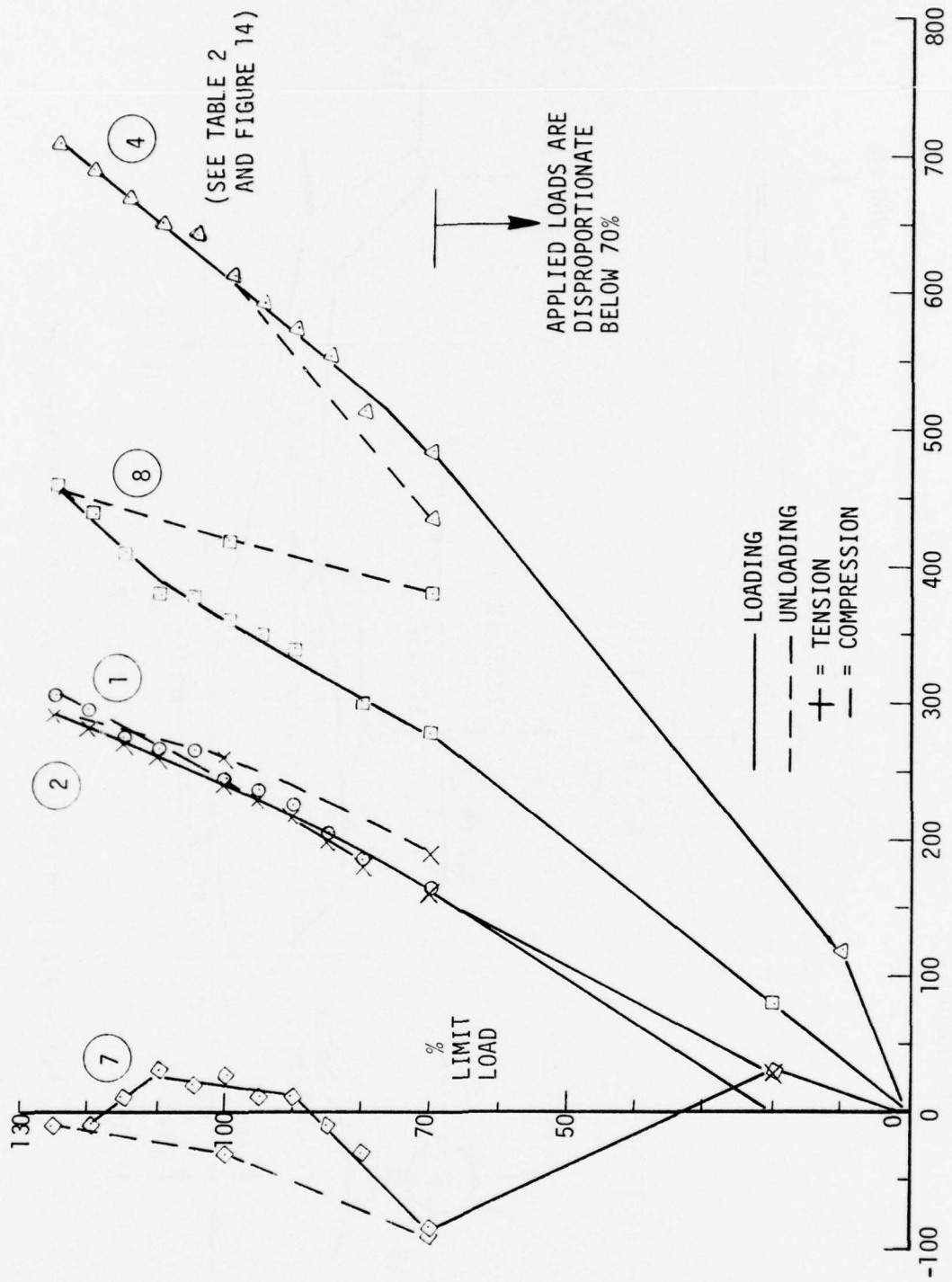

Figure 94. Strains From Transmission Support Plate

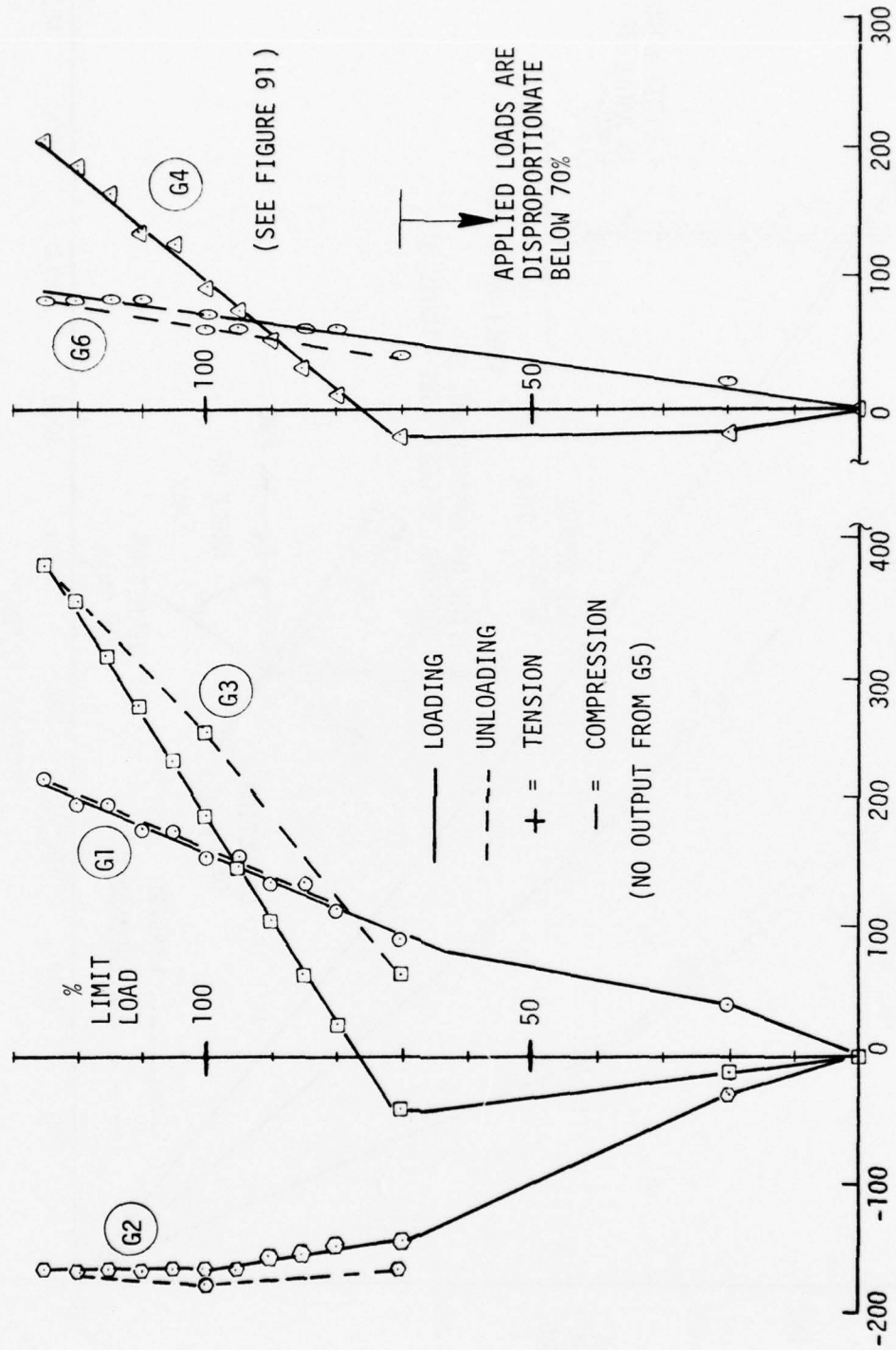

Figure 95. Strains From Fuselage Gages

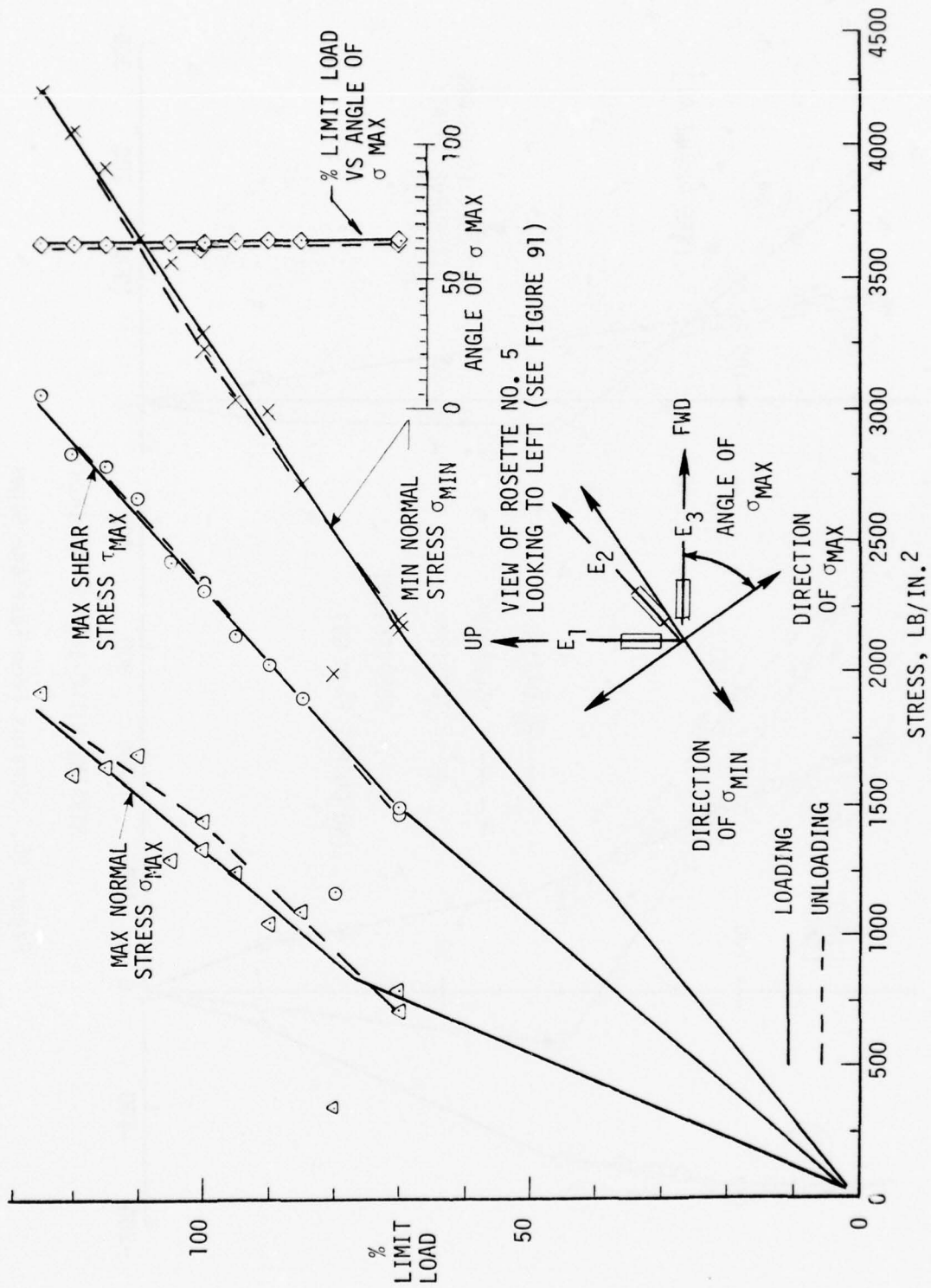

Figure 96. Rosette Strain Gage No. 5, Measured Stresses

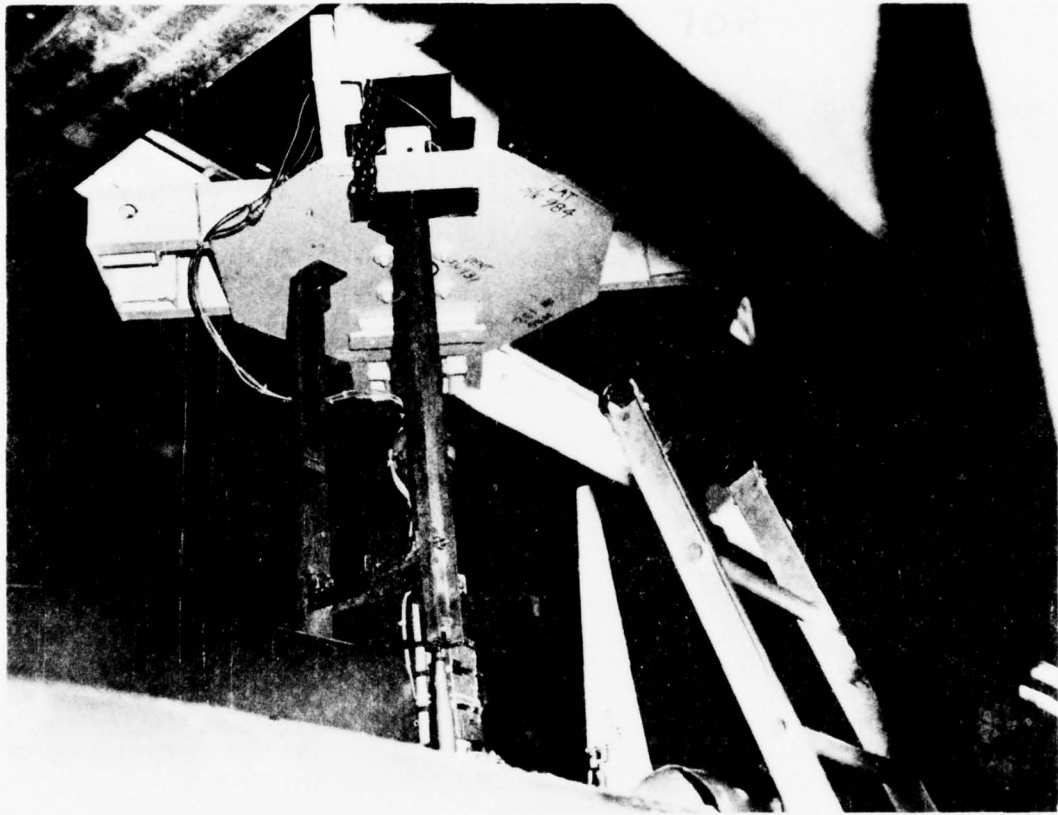

Figure 97. Proof Load Test of Modified Flight Controls

Loads of 112.5 pounds (.75 x 150 pounds) were applied simultaneously at the center of each collective control stick handgrip, perpendicular to the stick centerline, and in the plane of movement of the stick. The loads were applied in a forward direction starting with the sticks against the aft stops.

In order to correctly load the servo rods and the support beams which straddle the transmission, the pertinent control actuators were activated with hydraulic pressure throughout each test.

Test Setup - The helicopter was positioned on the safety cradle within the structural test frame, and the control system tests were conducted. During each control system test, the pertinent control system was jammed or locked to the dummy rotor hub through specially made struts, Figure 97. The collective system required a tension strut between the dummy rotor hub and the upper end of the collective control servo actuator, while the cyclic system required a pair of compression struts between the dummy rotor hub and the upper ends of the cyclic control servo actuators.

Continuous hydraulic pressure was applied to the pertinent servo actuators during each test to ensure the correct load in the actuators and the rods above and, therefore, in the actuator support beams as well. The helicopter hydraulic system pressure is 1000 psi, and this pressure was applied by a hand-operated wobble pump. Forces were applied to the control sticks through a system of light steel channels and steel cables. The application of force was accomplished by a turnbuckle attached to the structural test frame.

Instrumentation - The force applied to the control sticks was measured by a strain-gage-type calibrated link located at the force-application turnbuckle. The electrical output of the calibrated link was measured on an SR-4 Portable Strain Indicator.

Forces were measured in each of three control rods by an axial strain gage bridge mounted approximately in the center of each rod. Each bridge was calibrated prior to the test by applying a known axial force to the rod while reading the strain output.

Two single strain gages were applied to the left-hand lower lug of the cyclic control actuator support beam, XK 221202. The lug referred to is the one which engages the DAVI spindle through the transmission mounting foot. The gages were oriented to measure strain in the athwartship (lateral) direction.

Test Procedure - For each system being tested, the required control stick force was applied in incremental steps of 20 percent of the maximum proof load. At each step, the applied force and the servo actuator hydraulic pressure were maintained constant while strain and deflection readings were taken.

The maximum force that was applied was 100 percent of the specified jam load.

Strain and deflection readings were taken at 0 percent, 20 percent, 40 percent, 60 percent, 80 percent and 100 percent of the jam loads during loading, and at 20 percent during unloading.

Test Results - The modified control system withstood the application of the proof load without failure or permanent set.

Figures 98 and 99 are graphs of stick displacements and control rod loads obtained during the tests. The outputs from the two strain gages on the cyclic control actuator support beam were so low that they were not plotted. The complete results of the proof load test and control tests are given in Reference 20.

Ground Vibration Survey

Test Setup and Configurations

Ground vibration surveys were done on the UH-1H helicopter for four basic configurations. These configurations were:

1. Unmodified helicopter - conventional isolation
2. Rigid system - conventional system locked out
3. DAVI system with unmodified helicopter friction dampers
4. DAVI system without friction dampers.

Each configuration of the test vehicle was placed in the Kaman Structural Test Facility static test frame as shown in Figure 100. The main rotor and hub were replaced with a dummy hub that was equivalent in weight to the actual system, and the test vehicle was suspended at the hub by a soft bungee to simulate a free-free system. All configurations of the test vehicle were ballasted to 8250 pounds.

The shake tests for all configurations were done in a similar manner. For each, a frequency sweep was made from 2 Hertz to 25 Hertz for a force input at the main rotor hub in the vertical, longitudinal and lateral directions. The forces were applied independently and had approximately a 1000-pound magnitude except at resonance.

²⁰ Luff, TEST RESULTS - STATIC PROOF LOAD TEST OF A DAVI MODIFIED UH-1H HELICOPTER, Kaman Aerospace Corporation, Bloomfield, CT, Kaman Report T-626-1, April 1975.

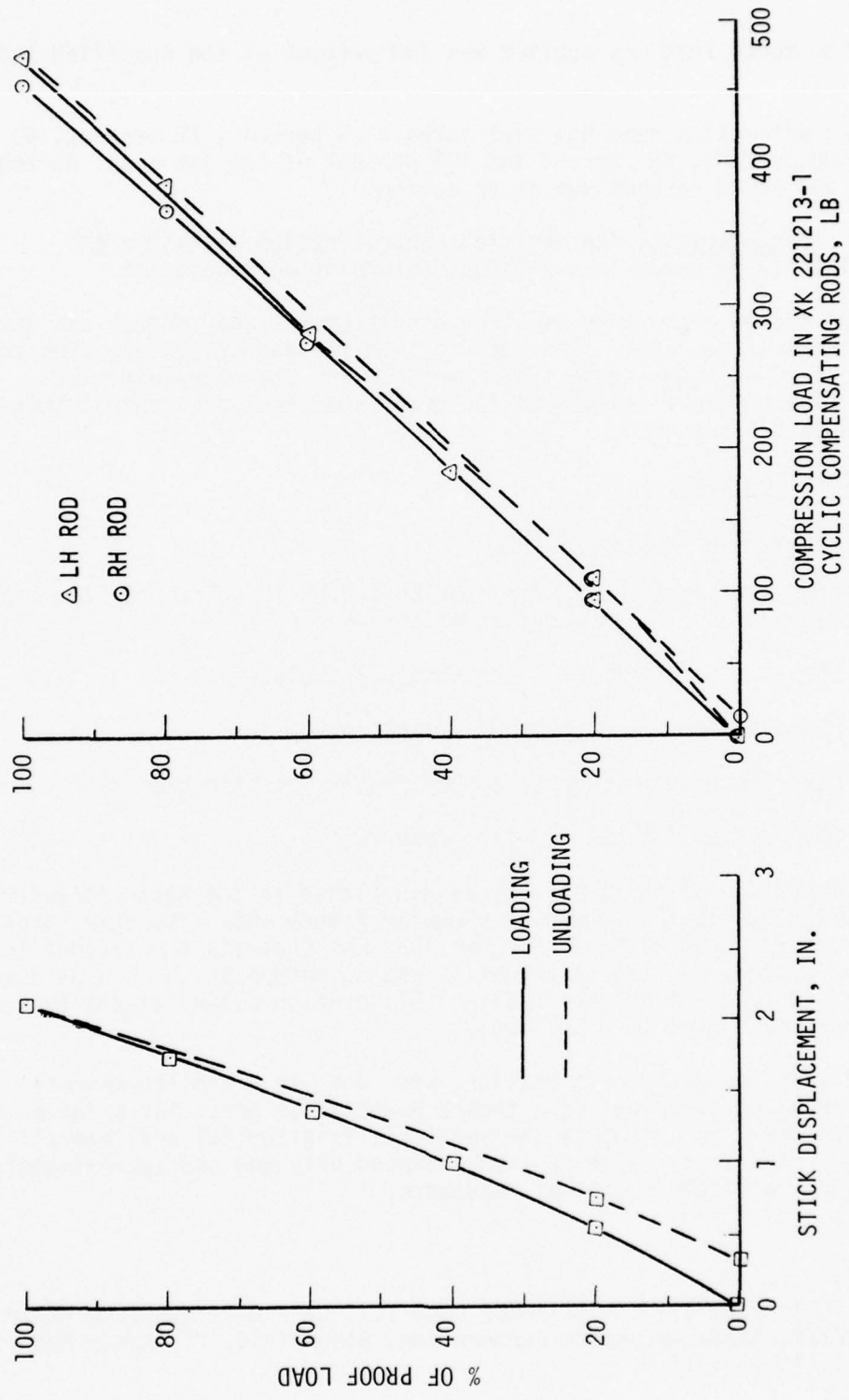

Figure 98. Proof Load Test, Cyclic Controls

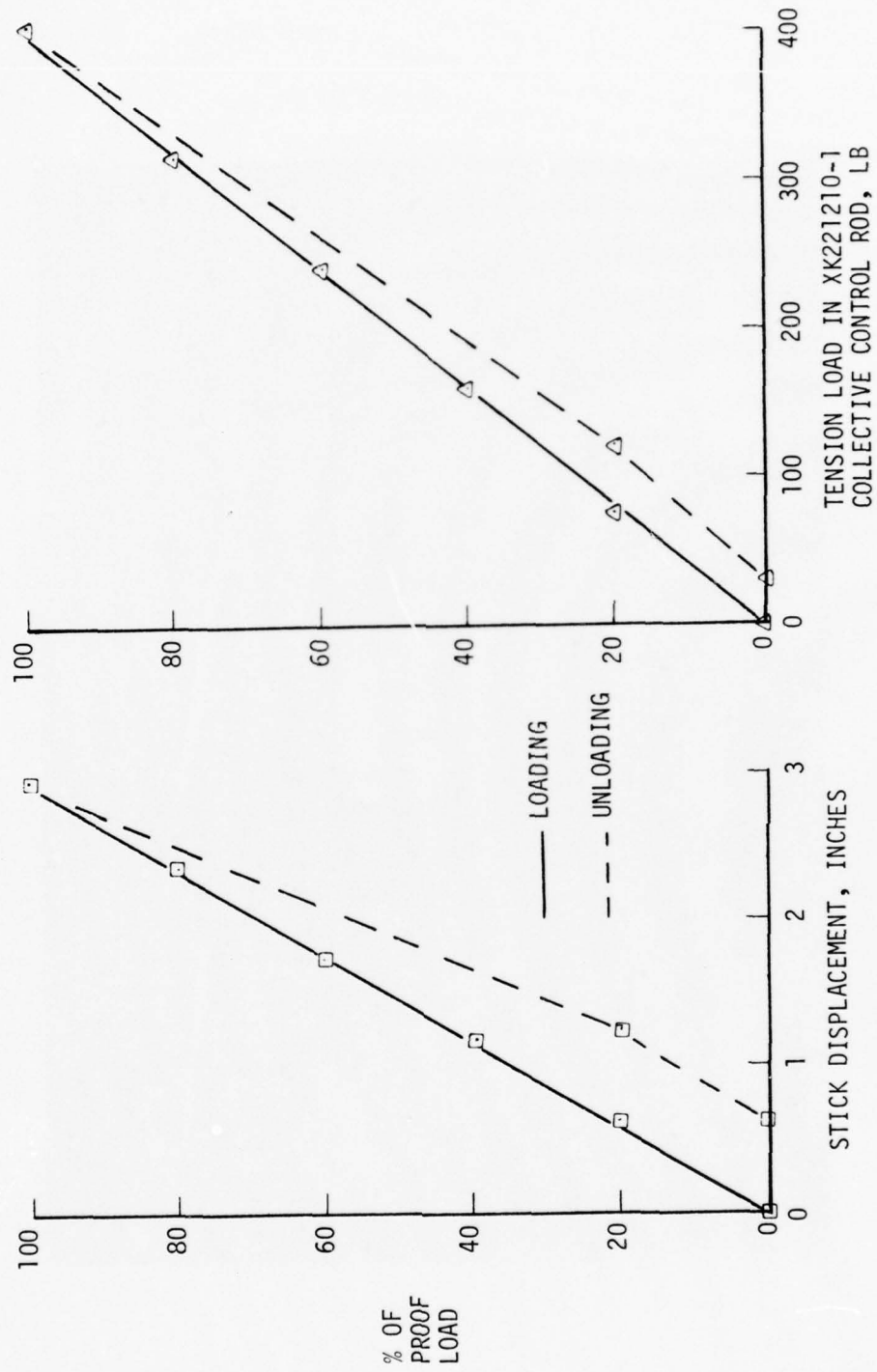

Figure 99. Proof Load Test, Collective Controls

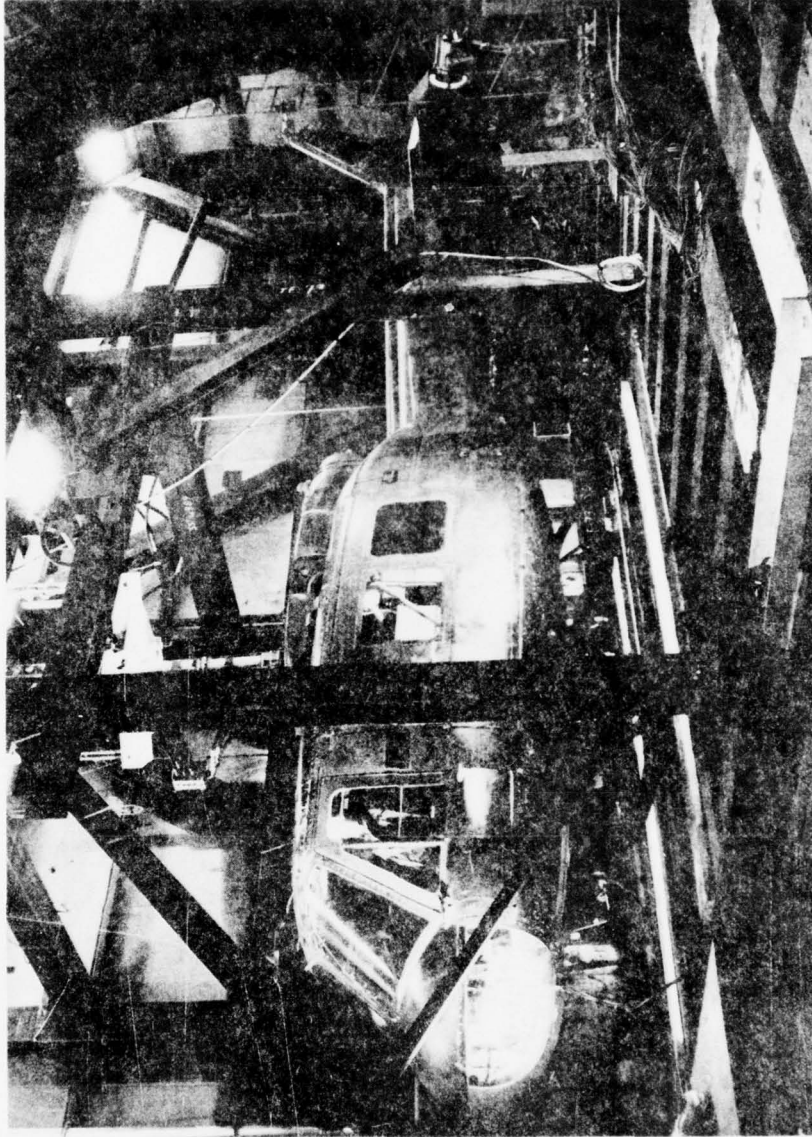

Figure 100. Baseline Ground Vibration Survey Test Setup With UH-1H Helicopter in Position

The instrumentation used in these tests was identical for all configurations. Table 30 gives the instrumentation used. The only additional instrumentation was three strain gage load cells between the hydraulic shakers and the hub attachments to measure the vertical, longitudinal and lateral vibratory force inputs.

Test Results

Figure 101 shows the typical absolute acceleration mobility (acceleration/1000 lb) versus the frequencies of three of the configurations tested. This figure shows the vertical response of the tail for a vertical excitation at the main rotor hub for the rigid, standard, and DAVI with friction damper systems. Table 39 gives the predominant natural frequencies and responses at the natural frequencies of the test vehicles.

The results, as given in Table 39, were obtained from the imaginary accelerations obtained in the frequency sweeps made on the three configurations. Natural frequencies and responses were obtained from the peak values of the imaginary accelerations. The responses are all normalized with respect to the vertical motion at the tail.

For the first set of natural frequencies, it is seen that the natural frequencies and responses of the DAVI (3.2 Hertz) and the standard (3.1 Hertz) systems are essentially the same. Response is primarily pitching motion of the fuselage with some vertical flexibility of the tail, and this response is due to the low frequency isolation of the rotor system from the fuselage. The response of the rigid system (4.8 Hertz) is similar to DAVI and conventional systems, and although the isolation system was locked out with solid aluminum mounts, the low frequency is probably due to the flexibility of the main rotor shaft.

For the second set of natural frequencies, it is seen that the natural frequencies and responses of the DAVI (4.2 Hertz) and the conventional (4.1 Hertz) systems are similar also. The response is primarily the rolling motion of the fuselage with lateral flexibility of the tail and is due to the low frequency isolation of the rotor systems from the fuselage. The response of the rigid system (5.6 Hertz) is similar to the DAVI and conventional systems, and the low frequency is probably due to the flexibility of the main rotor shaft.

For the next three sets of natural frequencies, all three configurations had essentially the same natural frequencies. For the 5.7-Hertz and 7.6-Hertz frequencies, the responses were mostly the lateral motion of the fuselage. The 7.6-Hertz frequency responses were nearly identical for all three configurations. For the 5.7-Hertz frequency response, the DAVI system appears to have more torsional coupling than either the rigid or conventional systems. The 6.5-Hertz frequency response is largely the vertical flexibility of the fuselage, and all three configurations give the same response.

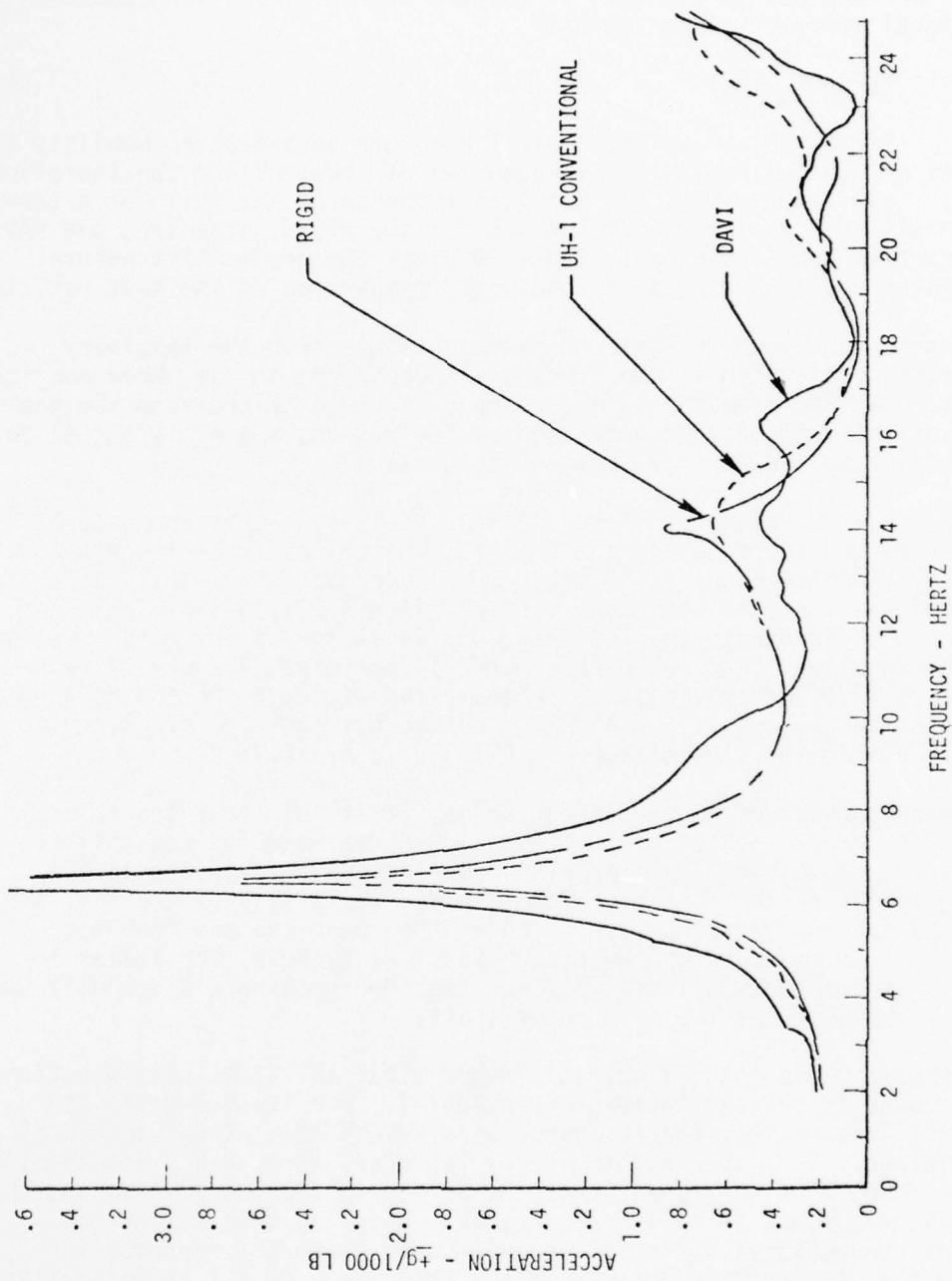

Figure 101. Vertical Response of the Tail for a Vertical Input at Main Rotor Hub

TABLE 39. PREDOMINANT NATURAL FREQUENCIES AND RESPONSES

Location		Normalized Responses and Natural Frequency - Hertz																		
		3.2	3.1	4.8	4.2	4.1	5.6	5.6	5.7	6.0	6.4	6.5	6.5	6.5	7.6	7.6	7.6	7.6	9.9	
Direction		DAVI	Conv	Rigid	DAVI	Conv	Rigid	DAVI	Conv	Rigid	DAVI	Conv	Rigid	DAVI	Conv	Rigid	DAVI	Conv	Rigid	DAVI
Nose	Vertical	-.28	-.30	-.08	-.29	-.24	-.30	.05	.56	.32	.29	.35	.33	-.07	.12	.05	-.07	.12	.05	.07
	Lateral	-	-	-	-.93	-.94	-2.15	-.39	3.85	4.55	-.02	-.04	-.03	-1.53	-1.33	-1.50	-1.53	-1.33	-1.50	-.02
	Longitudinal	.08	.07	.09	-.02	0	0	.06	0	-.02	.04	.05	.04	-.07	.10	.11	-.07	.10	.11	-.05
Pilot	Vertical	-.14	-.18	-.05	1.34	1.28	.38	-.21	.63	2.62	.12	.20	.18	-.56	-.57	-.81	-.56	-.57	-.81	-.07
	Lateral	.14	.11	.08	-.62	-.62	-1.33	-.36	-.51	2.34	-.01	-.03	-.03	-.68	-.61	-.63	-.68	-.61	-.63	-.01
	Longitudinal	-	-	-	-.23	.31	.42	.17	2.08	-.62	.01	.01	-	.31	.29	.33	.31	.29	.33	-.03
Co-Pilot	Vertical	-.20	-.18	-.07	-1.50	-1.91	-.85	.18	0	-2.25	.14	.22	.21	.52	.73	.83	.52	.73	.83	-.09
	Lateral	.13	.12	.09	-.58	-.57	-1.45	-.46	2.02	2.58	-.02	-.02	-.02	-.69	-.59	-.69	-.69	-.59	-.69	-.02
	Longitudinal	-	-	-	-.32	-.28	-.42	-.02	.64	.47	-.01	-.01	-.01	-.22	-.19	-.18	-.22	-.19	-.18	-.03
Trans	Vertical	-.03	-.17	-.04	.17	.21	.01	.21	-.19	-.46	-.08	-.06	-.08	-.03	-.02	-.01	-.03	-.02	-.01	1.20
	Lateral	-.18	-.13	.03	-.56	-.50	-.67	1.66	-1.41	-4.58	-.01	.01	.01	1.58	1.83	2.17	1.58	1.83	2.17	-
	Longitudinal	-	-	-	.09	-.09	.01	-.05	-.02	-.36	-.03	-.04	-.05	-.07	.02	.07	-.07	.02	.07	-.63
CG	Vertical	-.01	.06	-.02	-	.07	-	-.12	-.32	-	-.05	-.05	-.06	-.08	-.06	-.06	-.08	-.06	-.06	-.23
	Lateral	-.02	.01	-	-.41	-.55	-	.25	.62	-1.05	.01	-	-	.77	.73	.87	.77	.73	.87	-
	Longitudinal	.17	.14	.09	.06	.25	.15	-.05	-.03	.11	-	-.01	-.01	-.03	-.05	.05	-.03	-.05	.05	-.01
Tail	Vertical	1.00	1.00	1.00	1.00	1.00	1.00	1.00	1.00	1.00	1.00	1.00	1.00	1.00	1.00	1.00	1.00	1.00	1.00	1.00
	Lateral	-.03	.02	.14	-5.13	-5.56	-12.53	3.18	20.48	27.41	-.14	-.18	-.16	-5.64	-4.25	-5.08	-5.64	-4.25	-5.08	-.02
	Longitudinal	.48	.45	.48	-.14	.39	-11.00	.30	.62	.77	1.716	.52	.51	.37	.59	.57	.37	.59	.57	-.89

The 9.8-Hertz natural frequency and response was introduced due to the DAVI system vertical flexibility and is essentially the upper body motion relative to the fuselage with some vertical flexibility of the tail.

It is seen from these results that the DAVI did not alter any of the low frequency modes, which are essentially identical to those of the conventional system. The DAVI system, as expected, did introduce a new vertical mode well above the main rotor operating range of the UH-1 helicopter.

Table 40 shows the results obtained for the one-per-rev, two-per-rev, and four-per-rev excitation frequencies of the UH-1 helicopter. These results are for the vertical, longitudinal and lateral excitations at the hub and are in $\pm g/1000$ pounds.

It is seen in Table 40 that, for the vertical excitation, the vertical response with the DAVI system for the one-per-rev excitation is amplified somewhat at the nose and tail but is essentially the same as the standard UH-1 at the pilot and copilot stations. For the two-per-rev excitation, the DAVI system gives approximately a 2 to 1 reduction in vertical response of the vehicle except at the tail. For the four-per-rev excitation, the DAVI system has approximately a 2 to 1 reduction in vertical response of the vehicle at the nose and pilot seat stations and approximately the same levels at the remaining stations. In almost all cases, the DAVI system without the friction dampers gave lower vibration levels than with the dampers.

For the longitudinal excitation at the hub, it is seen from Table 40 that the DAVI system has lower responses for most directions of motion on the fuselage than either the rigid or conventional system for the one-per-rev and two-per-rev excitation frequencies. For the four-per-rev excitation frequency, the DAVI system has greater response than the conventional system and similar responses to the rigid system. In almost all cases, the DAVI system without friction dampers gave lower vibration levels than with the dampers.

For the lateral excitation at the hub, the DAVI system has lower response than the conventional and rigid systems for the one-per-rev excitation. For the two-per-rev excitation, the DAVI and conventional systems gave similar responses, both lower than the rigid system. For the four-per-rev excitation, the DAVI system has higher response than the conventional system and, in some locations, higher than the rigid system. In most cases, the DAVI system without dampers gave lower vibration levels than with the dampers.

In general, the DAVI system gives lower responses for the one-per-rev and two-per-rev excitations and higher responses for the four-per-rev excitation than the conventional system. There is apparently greater coupling between vertical and lateral motions than in either the conventional or rigid system. This may be due to the local structural modification made in the UH-1 for the installation of the DAVI system.

TABLE 40. PREDOMINANT VIBRATION LEVELS OF THE UH-1H HELICOPTER

		Vertical Excitation											
Transducer		One-Per-Rev (+g)				Two-Per-Rev (+g)				Four-Per-Rev (+g)			
Station	Direction	Rigid	Conv	Dampers	Without Dampers	Rigid	Conv	Dampers	Without Dampers	Rigid	Conv	Dampers	Without Dampers
Nose	Vertical	.304	.300	.365	.342	.104	.137	.076	.061	.207	.259	.142	.140
	Lateral	.035	.033	.058	.034	.015	.019	.008	.009	.047	.140	.154	.175
	Long.	.043	.041	.050	.047	.012	.012	.016	.009	.065	.069	.024	.081
Pilot	Vertical	.228	.225	.215	.251	.103	.121	.055	.065	.104	.236	.092	.091
	Lateral	.017	.014	.024	.007	.006	.006	.005	.002	.047	.056	.057	.048
	Long.	.008	.003	.005	.003	.025	.030	.019	.018	.086	.131	.055	.100
Co-Pilot	Vertical	.247	.241	.233	.232	.125	.141	.064	.063	.290	.316	.298	.172
	Lateral	.021	.016	.026	.016	.008	.012	.005	.006	.050	.049	.041	.095
	Long.	.009	.011	.015	.004	.023	.027	.015	.015	.105	.078	.087	.124
CG	Vertical	.083	.089	.080	.092	.075	.061	.053	.046	.210	.227	.258	.240
	Lateral	.002	-	.005	.003	.003	.003	.002	.003	.038	.060	.013	.023
	Long.	.002	.006	.008	.005	.014	.009	.007	.003	.019	.048	.052	.039
Tail	Vertical	.675	.581	.996	.726	.353	.367	.299	.208	.125	.285	.272	.289
	Lateral	.195	.164	.332	.193	.017	.021	.017	.016	.068	.131	.113	.203
	Long.	.278	.235	.407	.312	.389	.405	.306	.224	.050	.222	.110	.081

TABLE 40 (Continued)

Longitudinal Excitation													
Transducer		One-Per-Rev (+g)			Two-Per-Rev (+g)			Four-Per-Rev (+g)					
Station	Direction	Rigid	Conv	Dampers	Without Dampers	Rigid	Conv	Dampers	Without Dampers	Rigid	Conv	Dampers	Without Dampers
Nose	Vertical	.072	.012	.003	-	.159	.109	.058	.027	.099	.028	.113	.102
	Lateral	.157	.036	.073	.024	.006	.002	.008	.002	.094	.010	.024	.054
	Long.	.230	.090	.057	.053	.015	.017	.016	.017	.042	.002	.025	.033
Pilot	Vertical	.011	.037	.016	.007	.082	.052	.035	.016	.111	.014	.063	.069
	Lateral	.104	.002	.042	-	-	-	-	-	.044	.002	.008	.018
	Long.	.155	.044	.048	.041	.032	.029	.019	.015	.071	.007	.035	.042
Co-Pilot	Vertical	.034	.001	.008	-	.093	.062	.014	.004	.164	.008	.278	.249
	Lateral	.124	.029	.044	-	.001	.002	-	-	.036	.010	.042	.022
	Long.	.231	.086	.067	.039	.038	.032	.020	.016	.070	.006	.055	.053
CG	Vertical	.027	.036	.021	.010	.034	.027	.020	.005	.160	.021	.082	.095
	Lateral	.003	.001	.010	.001	.001	-	.008	.007	.030	.005	.041	.042
	Long.	.182	.072	.056	.049	.022	.021	.017	.016	.044	.004	.048	.056
Tail	Vertical	3.138	.981	.645	.533	.048	.029	.056	.006	.240	.029	.261	.301
	Lateral	1.092	.240	.478	.172	.003	.002	.021	.020	.152	.012	.101	.119
	Long.	1.543	.496	.370	.266	.062	.010	.062	.026	.085	.005	.094	.115

TABLE 40 (Concluded)

Lateral Excitation												
Transducer	One-Per-Rev (+g)			Two-Per-Rev (+g)			Four-Per-Rev (+g)			Without Dampers		
	Rigid	Conv	Dampers	Rigid	Conv	Dampers	Rigid	Conv	Dampers	Rigid	Conv	Dampers
Station Direction			Without Dampers			Without Dampers			Without Dampers			Without Dampers
Nose												
Vertical	.202	.036	.033	.033	.033	.033	.012	.005	.013	.022	.097	.215
Lateral	2.232	.322	.183	.161	.006	.006	.049	.018	.006	.006	.044	.052
Long.	.007	-	.007	.004	.001	.001	.005	.002	.001	.002	.017	.022
Pilot												
Vertical	.801	.103	.079	.045	.045	.045	.081	.041	.032	.021	.099	.052
Lateral	1.170	.194	.100	.080	.080	.080	.022	.008	.017	.017	.020	.070
Long.	.432	.058	.040	.001	.001	.001	.011	.006	-	-	.031	.025
Co-Pilot												
Vertical	1.169	.175	.128	.116	.116	.116	.091	.053	.026	.026	.082	.425
Lateral	1.319	.189	.109	.070	.070	.070	.023	.008	.017	.017	.016	.076
Long.	.447	.057	.033	.026	.026	.026	.003	.002	-	.003	.015	.077
CG												
Vertical	.009	.017	.006	-	-	-	.002	.002	.004	.002	.040	.047
Lateral	.017	.025	.021	.035	.035	.035	.051	.035	.039	.038	.037	.075
Long.	.161	.024	.006	-	-	-	.004	.003	.001	.002	.006	.036
Tail												
Vertical	.031	.083	.061	.037	.037	.037	.035	.024	.009	.022	.038	.163
Lateral	11.165	1.499	.745	.721	.721	.721	.153	.106	.110	.109	.074	.161
Long.	.158	.034	.040	.012	.012	.012	.025	.017	.006	.023	.041	.080

Also, the DAVIs for the UH-1 have been designed with spherical (rigid) bearings. Better high frequency (four-per-rev) isolation can be obtained with flexible pivots.

Also, the shake test was conducted with a lumped mass at the rotor head that was equivalent to the mass of the main rotor blades and hub, and also with a lumped mass for the tail rotor system. Therefore, the effects of main rotor and tail rotor impedance versus frequency are not included in the results. The effect of main rotor and tail rotor impedances could affect the results given in Table 40.

SYSTEM ANALYSES

PREDICTED VIBRATORY RESPONSES

In order to determine the expected vibration level in-flight, the vibratory forces were obtained from flight and shake-test data on the UH-1H helicopter. The forces were calibrated using the real and imaginary mobilities obtained in the shake test and using the real and imaginary responses obtained with respect to the rotor bopper in flight. The one-per-rev, two-per-rev and four-per-rev forces were calculated versus speed.

These forces were then applied to the measured mobilities of the rigid system, the DAVI with dampers, and the DAVI without dampers to obtain the expected vibration in flight. No effects of the change of the rotor impedance due to these configurations were considered. Table 41 shows the expected vertical vibration levels on the UH-1H at 116 knots. In this table, transmissibility (T) is obtained by dividing the isolated responses by the rigid responses.

For the one-per-rev excitation frequency, all configurations show low vibration levels, and the vibration levels throughout the ship except for the tail are essentially the same. At the tail location, the DAVI system shows a vibration level equivalent to that of the rigid system, whereas the conventional system shows a slight reduction.

For the two-per-rev excitation frequency, the DAVI system shows an excellent improvement over the rigid and conventional systems. In the forward sections of the fuselage, the nose and pilot seat have approximately one-fifth the vibration levels and the copilot seat has approximately one-third the vibration level of the rigid system. At the tail, the DAVI system and conventional system have about the same vibration levels with only a slight improvement over the rigid system.

For the four-per-rev excitation frequency, the rigid system has lower vibration levels than either the conventional or DAVI system. The DAVI system shows an increase in vibration levels at the copilot seat location and a decrease in vibration levels at the tail location over the conventional isolation systems.

TABLE 41. EXPECTED VERTICAL VIBRATION LEVELS OF THE UH-1H HELICOPTER AT 116 KNOTS

One-Per-Rev (+g)							
Transducer	Rigid	Conv	T*	DAVI			
				Dampers	T*	Without Dampers	T*
Nose	.032	.040	1.25	.044	1.38	.041	1.28
Pilot	.037	.031	.84	.026	.70	.030	.81
Copilot	.018	.030	1.67	.027	1.50	.027	1.50
CG	.012	.012	1.00	.009	.75	.011	.92
Tail	.094	.067	.71	.125	1.33	.093	.99
Two-Per-Rev (+g)							
Nose	.321	.273	.85	.075	.23	.007	.02
Pilot	.341	.164	.48	.063	.18	.047	.14
Copilot	.264	.273	1.08	.097	.37	.086	.33
CG	.060	.073	1.22	.069	1.15	.045	.75
Tail	.276	.230	.83	.246	.89	.187	.68
Four-Per-Rev (+g)							
Nose	.024	.070	2.9	.055	2.3	.056	2.3
Pilot	.019	.038	2.0	.011	.58	.010	.52
Copilot	.032	.008	.25	.117	3.7	.091	2.8
CG	.010	.02	2.0	.019	1.9	.021	2.1
Tail	.026	.107	4.0	.055	2.1	.071	2.7
* T - Transmissibility = Response Ratio $\left(\frac{\text{Conventional System}}{\text{Rigid System}}\right)$ or $\left(\frac{\text{DAVI System}}{\text{Rigid System}}\right)$							

Figure 102 shows the two-per-rev vertical-response-versus-speed expected in flight for all configurations. It is seen in this figure that at the nose location of the vehicle the DAVI system gives a much lower vibration level than either the conventional or rigid systems throughout the speed range. At the pilot seat location, the DAVI and conventional systems have similar vibration levels at the low speeds, both systems much lower than the rigid system. At the higher speeds, the DAVI system has a vibration level one-third that of the conventional system and less than one-fifth the level of the rigid system. At the copilot station, the DAVI system has a much lower vibration level than either the conventional or the rigid system throughout the speed range. The DAVI system shows the least decrease in vibration level over the conventional and rigid system at the tail locations. However, at the 60-knot speed condition, there is a 2-to-1 reduction over the rigid system for the DAVI without dampers. In most cases, the DAVI without dampers had the lowest vibration levels.

From the results obtained on the shake test and the calculated expected vibration levels, the DAVI system did reduce the two-per-rev vibration levels substantially. Since the DAVI system without dampers did give the lowest vibration levels, this was considered the final configuration for the DAVI-modified vehicle.

MECHANICAL STABILITY

The UH-1 helicopter has well known dynamic characteristics. In order to minimize costs in analysis and test, the DAVI-modified UH-1 system was designed to have inplane and torsional dynamic characteristics similar to those of the unmodified vehicle to insure freedom from mechanical instability and to insure rotor, transmission, and engine torsional compatibility.

Mechanical instability is coupling between the inplane blade motions and the inplane hub motions of the isolated helicopter and/or of the helicopter on its landing gear. The center of mechanical instability, which is the rotor speed at which the instability is most critical, is given by the following relationship:

$$\omega_n + \omega_B = \Omega_{M.I} \quad (4)$$

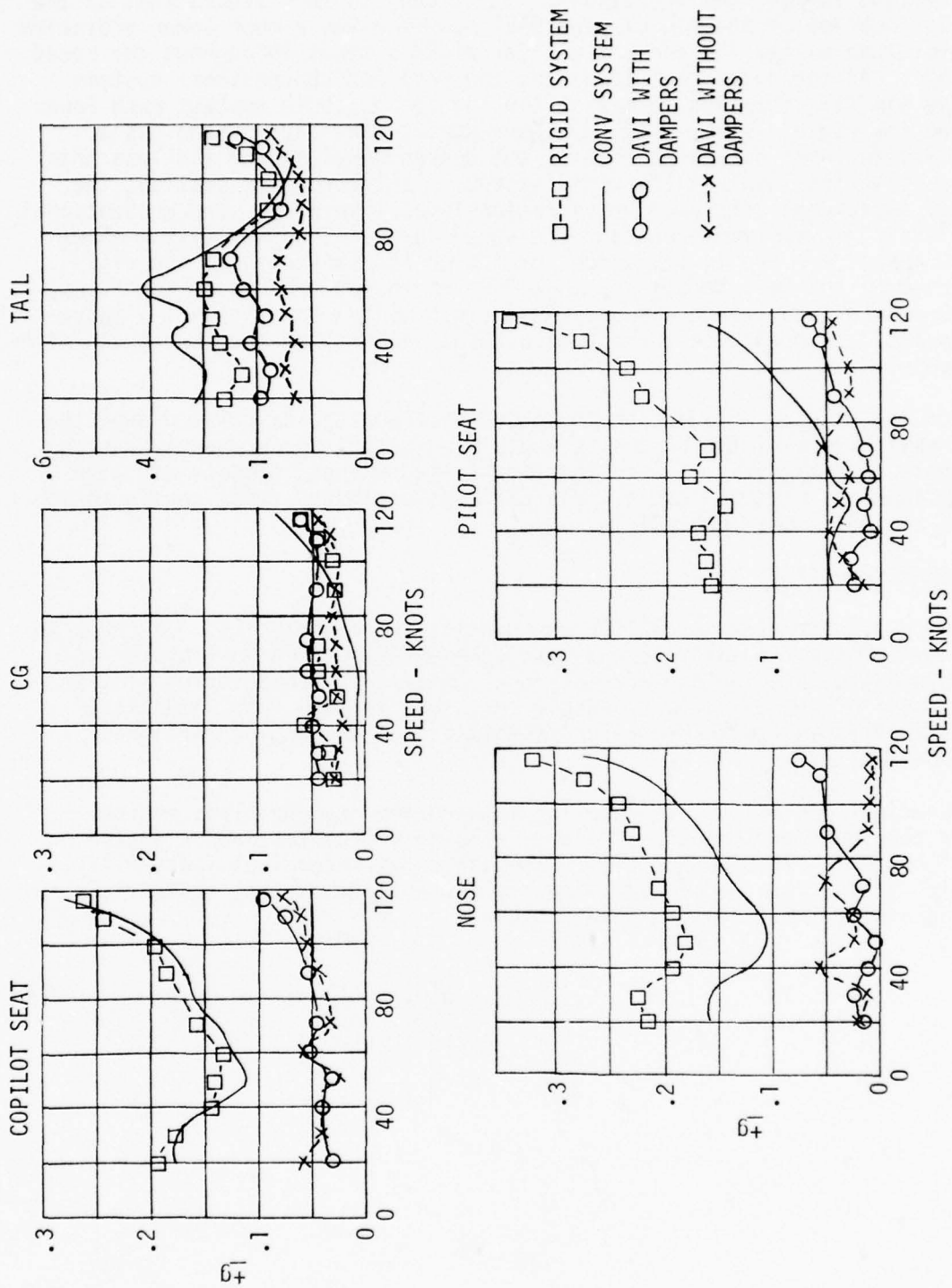

Figure 102. Two-Per-Rev Vertical Response

in which

ω_n = inplane natural frequencies of the isolation system and/or of the helicopter on its landing gear

ω_B = inplane blade natural frequencies

$\Omega_{M.I.}$ = rotor speed for center of mechanical instability

For two-bladed helicopters, flywheel resonance can be a problem. The characteristics of this form of instability are one-per-rev response in the fixed system and inplane divergence of the blades.

The range of instability can be calculated from the following equation (Reference 21), which is modified for a hingeless inplane rotor system:

$$\left[\left(1 - \frac{\Omega^2}{\omega_h^2} \right) \frac{\omega_B^2}{\omega_h^2} - 2 \frac{m_e}{M_e} \frac{\Omega^4}{\omega_h^4} \right] \left[1 - \frac{\Omega^4}{\omega_h^4} \right] = 0 \quad (5)$$

where

Ω - rotor speed, rad/sec

ω_h - natural frequency of the inplane hub motion including the blades as a lumped mass of the hub, rad/sec

ω_B - natural frequency of the blade as a cantilever in rotation, rad/sec

m_e - effective mass of the blade in the first cantilever bending mode, slugs

M_e - effective mass of the hub including the mass of the blades, slugs

An inspection of the equation shows that the upper limit of this flywheel resonance is the natural frequency of the inplane hub motions. The standard UH-1 helicopter has been designed to have a low inplane frequency (below one-per-rev) to isolate two-per-rev vibratory hub loads and to avoid significantly amplifying the one-per-rev loads.

²¹ Coleman and Feingold, THEORY OF SELF-EXCITED MECHANICAL OSCILLATIONS OF HELICOPTER ROTORS WITH HINGED BLADES, NACA TN 3844, Langley Aeronautical Laboratory, Langley Field, VA, February 1957.

In order to achieve similar dynamic characteristics in the DAVI-modified UH-1H, the isolation system was designed to give the same low inplane natural frequencies. However, rather than comparing calculated natural frequencies, the best comparison can be made from the shake test of the unmodified and DAVI-modified UH-1H helicopter. Table 42 gives the results of the analysis of the shake test results in which structural damping (g) and undamped resonances were obtained.

It is seen from Table 42 that, for the longitudinal and lateral directions, essentially the same natural frequencies were obtained in all three configurations. The upper limit of flywheel resonance is, therefore, the same for all three configurations.

TABLE 42. UNDAMPED NATURAL FREQUENCY				
Configuration	Direction			
	Longitudinal		Lateral	
	Undamped Natural Frequency	Structural Damping g	Undamped Natural Frequency	Structural Damping g
Standard	3.1 Hertz	.172	4.1 Hertz	.183
DAVI With Friction Dampers	3.2 Hertz	.147	4.2 Hertz	.182
DAVI Without Friction Dampers	2.8 Hertz	.134	4.2 Hertz	.182

Table 43 gives the normalized responses of these three configurations at or near the natural frequency of the low-longitudinal and pitching modes.

The responses in Table 43 were normalized to the vertical response at the tail. It is seen from this table that, for the three configurations, the responses are essentially identical, and the DAVI modification did not change the dynamic characteristics of this mode. Therefore, the flywheel resonance and the mechanical instability characteristics of the DAVI-modified UH-1 should be the same as those for the standard vehicle.

TABLE 43. NORMALIZED RESPONSE

Location	Direction	Longitudinal Shake			Lateral Shake		
		Std	DAVI	DAVI	Std	DAVI	DAVI
			With Dampers	Without Dampers		With Dampers	Without Dampers
Nose	Vertical	-.30	-.28	-.27	-.24	-.29	-.16
	Lateral	-	-	-	-.94	-.93	-.84
	Long.	.07	.08	.08	-	-.02	-
Pilot	Vertical	-.18	-.14	-.11	1.28	1.34	1.17
	Lateral	-	-	-	-.62	-.62	-.41
	Long.	.11	.14	.15	.31	-.23	-
Copilot	Vertical	-.18	-.20	-.18	-1.91	-1.50	-1.69
	Lateral	-	-	-	-.57	-.58	-.56
	Long.	.12	.13	.11	-.28	-.32	-.25
Trans	Vertical	-.17	-.03	-.13	.21	.17	.17
	Lateral	-	-	-.04	-.50	-.56	-.29
	Long.	-.13	-.18	-.26	-.09	.09	.15
CG	Vertical	.06	-.01	-	.07	-	-
	Lateral	.01	-.02	-	-.55	-.41	-.42
	Long.	.14	.17	.17	.25	.06	.02
Tail	Vertical	1.00	1.00	1.00	1.00	1.00	1.00
	Lateral	.02	-.03	.03	-5.56	-5.13	-5.69
	Long.	.45	.48	.46	.39	-.14	-.06

ROTOR-ENGINE COMPATIBILITY

A detailed analysis of the rotor engine dynamics was not done. The primary variables in this type of analysis are the main rotor, drive system and power turbine equivalent inertias, the stiffness of the shafting and transmission systems mounting, the fuel control parameters and the component damping.

In the modification of the UH-1H helicopter, the only components to be changed were the isolation system and the structure supporting the isolation system. To insure similar dynamic characteristics, the torsional restraint of the DAVI isolation was designed to have the same torsional restraint as the unmodified UH-1H helicopter. In the UH-1H standard system, the torque is reacted by the radial spring rate of the tubular mount, thus giving identical spring rates in the longitudinal and lateral directions. In the two-dimensional DAVI isolation system in which the shear spring rate (longitudinal direction) is much softer than the compressive spring rate (lateral direction), the torque is reacted primarily by the compressive spring rate. To insure similar torsional restraint, the elastomeric spring rate of the DAVI in compression was designed to be 2.3 times stiffer than that of the standard mount.

The DAVI mount and the standard mount were statically tested to determine the spring rate. Table 44 shows the results of this test. The first column shows the static spring rates obtained for loads from 0 to 3000 pounds, and the second column shows the spring rates obtained by preloading the mounts to 3000 pounds and slowly oscillating the static test machine +500 pounds.

Mount	No Preload	3000 Lb Preload
DAVI	47,058 lb/in.	52,630 lb/in.
Standard	21,429 lb/in.	24,690 lb/in.

With reference to the spring rates as measured on the standard mount, the desired spring rates of the DAVI mount should be approximately 49,000 lb/in. to 56,700 lb/in. The actual measurement of the DAVI mount was within 5 to 8 percent of the design goal.

In order to further check the torsional restraint of the standard and DAVI isolation systems on the UH-1H helicopter, the torsional deflections of the transmission with respect to the fuselage were obtained in the flight of the standard UH-1H and in the proof test of the DAVI-isolated UH-1H.

Recordings of the nine potentiometers listed in Table 2 were resolved to give vertical, lateral, longitudinal, roll, pitch, and yaw deflections of the transmission, with respect to the fuselage. For the standard UH-1H, the yaw or torsional deflection of the mount with respect to the fuselage was determined to be 0.624 degree at 116 knots. The calculated rotor torque at this speed is 167,000 in.-lb. This gives an effective torsional spring rate of 267,628 in.-lb/deg for the standard UH-1H helicopter.

In the proof test of the DAVI-isolated vehicle, 134,585 in.-lb and 192,264 in.-lb of torque were applied for the 70-percent and 100-percent limit loads, respectively. The torsional deflections were determined to be 0.537 degree and 0.779 degree, respectively, or an average spring rate of 248,672 in.-lb/deg. This is 7 percent softer than the standard UH-1H system.

These tests show that the standard and DAVI-modified UH-1H helicopters have essentially the same torsional restraints. Therefore, the engine and rotor dynamic characteristics should be similar.

RELIABILITY ANALYSIS

The purpose of the DAVI reliability analysis is to locate any critical failure areas of the design that would have serious effects on mission success and crew safety, and to direct appropriate attention toward improving the reliability of these critical design areas for future designs or for the modification of the existing experimental design. This is accomplished by a failure modes and effects analysis (FMEA), which is a qualitative reliability technique for systematically analyzing each possible failure mode within a hardware system design and identifying the effect of the failure on that system, the mission and the personnel.

The DAVI functional block diagram is shown in Figure 103, and the DAVI reliability block diagram is shown in Figure 104. These diagrams aid in isolating and itemizing those components whose successful performance is critical to the proper operation of the DAVI design. A detailed list of these critical components follows:

Transmission DAVI Isolators

- N-1 Transmission Case Mounting
- N-2 Rubber Spring
- N-3 Pivot Bearing
- N-4 Inertia Arm
- N-5 Inertia Weight
- I-1 Isolated Fuselage Mounting
- I-2 Pivot Bearing

Lift-Link DAVI Isolator

- N-1 Upper Attachment (Nonisolated)
- N-2 Rubber Spring
- N-3 Pivot Bearing (2)
- N-4 Inertia Arm (2)
- N-5 Inertia Weight (2)
- I-1 Lower Attachment (Isolated)
- I-2 Pivot Bearing (2)

Although the designs of these components differ somewhat for the DAVI transmission isolators and the DAVI lift link, the components are functionally identical. Therefore, a failure modes and effects analysis has been performed which is applicable to both DAVI isolator and DAVI lift-link components.

The FMEA evaluates each of the critical components in turn to establish possible modes of failure, the causes of failure, the effects of failures on operation of the DAVI unit, and qualitative estimates of the criticality of the failure to safety and mission success. A subjective classification of the expected probability of failure is also given for

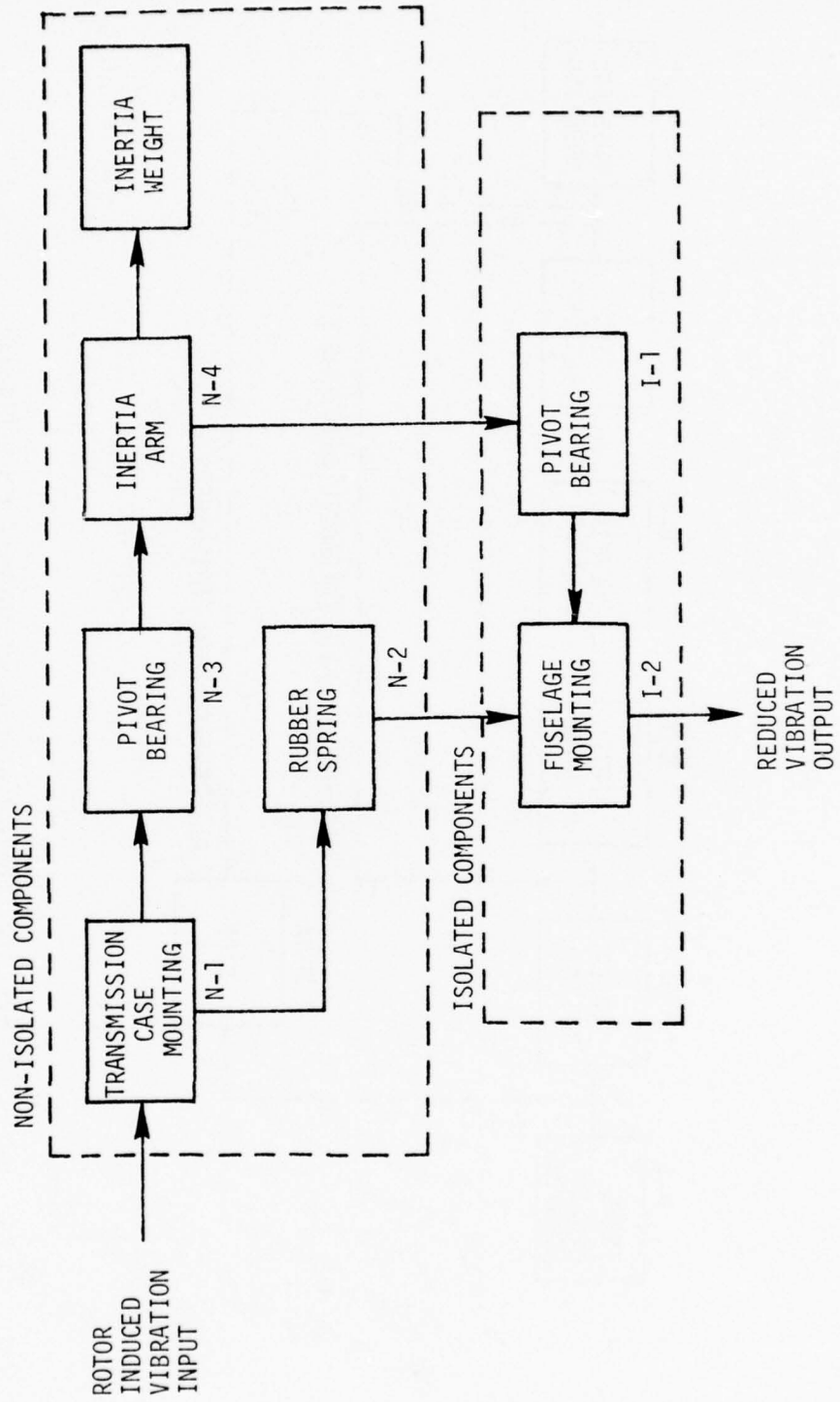

Figure 103. DAVI Isolator Functional Block Diagram

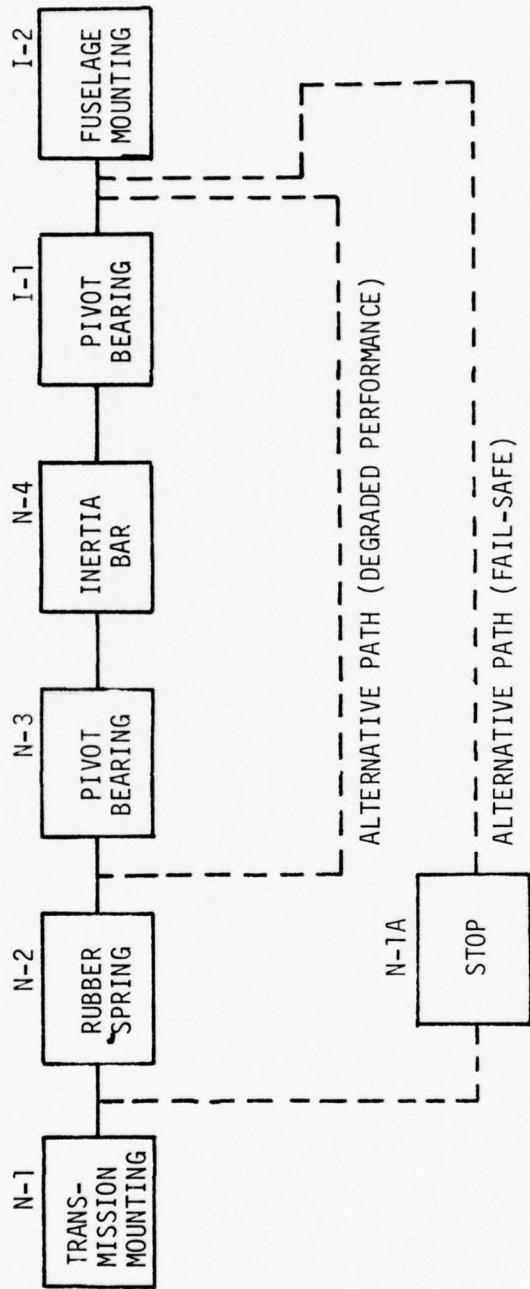

Figure 104. DAVI Isolator Reliability Block Diagram

each component evaluated. The failure criticality category and probability classification codes used are defined as follows:

Failure Criticality Categories

Category I: Negligible - Any nuisance failure not serious enough to be classified in a higher category that is not expected to result in personnel injury or aircraft system damage but will require corrective action during routine preventive maintenance.

Category II: Marginal - Any failure that is expected to degrade performance or result in degraded operation which can be counteracted or controlled without injury to personnel or major aircraft system damage. It requires special operation techniques or alternative modes of operation that could be tolerated throughout a mission but should be corrected immediately upon completion of the mission.

Category III: Critical - Mandatory Abort - Any failure that is expected to result in complete loss of function and cause personnel injury/hazard or major aircraft system damage, or which will require immediate corrective action for personnel or aircraft system survival.

Category IV: Catastrophic - Any single failure which is expected to cause death or severe injury to personnel or loss of the aircraft system.

Failure Probability Classes

Class A: Probability of failure is not remote.

Class B: Probability of failure is remote.

Class C: Parts subject to rare, random failures.

Class D: Parts not expected to fail in service.

The detailed results of the DAVI failure modes and effects analysis are tabulated in Table 45.

TABLE 45. DAVI FAILURE MODES AND EFFECTS ANALYSIS

Nonisolated Mounting to Transmission				
Assumed Failure	Cause	Failure Effects	Failure Category	Reliability Class
Broken Mounting Bolt	Fatigue	Complete loss of DAVI unit function	III	D
Crack/Fracture in Attachment to Transmission	Fatigue	Complete loss of DAVI unit function	III	D
Crack/Fracture in Upper Corner of Cage	Fatigue	Degradation in isolation	II	C
Crack/Fracture in Lower Corner of Cage	Fatigue	Minimal degradation in isolation, could lead to loss of fail-safe feature if rubber springs failed	II	C
Crack/Fracture in Cage at Bearing	Fatigue	Degradation in isolation, could lead to rubber spring failure or loosening of bearing	II	C
Fracture at Fail-Safe Stops	Fatigue from pounding	Secondary failure, possible only if rubber springs fail, would cause complete loss of DAVI unit function	III	D
Broken Mounting Bolt	Fatigue	Degradation in isolation with possible bottoming against stop	II	D
Crack/Fracture at Bolt Hole	Fatigue	Degradation in isolation	II	D

TABLE 45 (Continued)

Rubber Springs					
Assumed Failure	Cause	Failure Effects	Failure Category	Reliability Class	
Deterioration	Fatigue aging, oil leakage, corrosive elements	Degradation in isolation; could lead to more serious spring failure and loss of isolation	I	A	
Tear	Fatigue, under-strength material	Significant loss of isolation; could lead to complete spring shear and total loss of isolation	II	B	
Shear	Overload, under-strength material	Complete loss of isolation; isolated mounting bottoms against transmission case mounting longitudinal stop	III	C	
Bond Failure	Overload, under-strength bonding	Complete loss of isolation; isolated mounting bottoms against transmission case mounting longitudinal stop	III	C	

TABLE 45 (Continued)

Pivot Bearings

Assumed Failure	Cause	Failure Effects	Failure Category	Reliability Class
Wear, Mechanical	Contact between bearing surfaces during use	Results in excessive bearing slop and gradual degradation in isolation	I	A
Wear, Fretting	Contact between bearing surfaces during use	Bearing surfaces become scored and metal particles break loose, resulting in gradual degradation in isolation	I	B
Wear, Galling	Contact between bearing surfaces during use	Bearing surfaces become rough, causing bearing to function erratically and resulting in degradation in isolation	II	C
Sticking	Wear particles from bearing surfaces; foreign matter contamination	Bearing functions intermittently, resulting in degradation in isolation	II	C
Jamming	Severe galling at bearing surfaces; foreign matter contamination	Bearing seizes and ceases to function, resulting in loss of isolation or failure of the inertia bar and degradation in isolation	III	C

TABLE 45 (Concluded)

Inertia Bar				
Assumed Failure	Cause	Failure Effects	Failure Category	Reliability Class
Bent	Fatigue, under-strength material	Inertia bar may become detuned, resulting in some degradation in isolation; possible interference between weight and adjacent structure	II	C
Broken	Fatigue, under-strength material	Degradation in isolation, particularly at tuned frequency. Broken bar may interfere with other aircraft systems	III	D
Wear at Bearing Interface	Fatigue, under-strength material	Bar becomes loose in pivot bearings; possibly some degradation in isolation	I	C
Broken Retaining Nut	Fatigue, under-strength material	Bar becomes loose and may separate from pivot bearings; degradation in isolation results. Separated bar may interfere with other aircraft systems	III	D

The most probable DAVI-isolator failures are predicted to be in the rubber springs and pivot bearings, with deterioration or wear of these components being judged the most likely failure modes. Failures of this type are not serious and can be corrected during routine maintenance. For this reason, they have been assigned a Category I criticality code. Of all the assumed spring and bearing failures, only bond failure and shear of the rubber spring and a jammed bearing are considered serious enough to warrant a Category III criticality code and to require a mandatory abort; however, none of these failures appears to be very probable. In addition, these are likely to be sequential failures that occur after one of the less serious initial failures is allowed to progress without corrective action being taken. Thus, the need for strict inspection and maintenance procedures to prevent serious failures is obvious.

The only other component failures assigned a Category III criticality code are not expected to occur during the service life of the isolation system, and therefore, they have been given the lowest probability of failure classification, Class D. None of the assumed failures for any of the DAVI components appears serious enough to cause the catastrophic loss of the aircraft.

The DAVI design concept is simple and reliable, and incorporates a fail-safe feature. If a serious spring failure occurs, the isolated fuselage mounting would be restrained by the stops of the nonisolated transmission mounting, both of which are primary structures, thus preventing a total separation. However, such a failure is very likely to cause a mandatory abort due to the high level of vibration transmitted to the fuselage through the primary structure, although rubber-to-rubber stops are provided.

The reliability of the DAVI pivot bearings is enhanced somewhat by the fact that the pilots do not take any static loads, all of the steady loads being reacted by the rubber springs. The failure of bearings in the DAVI inertia coupling subassembly is most likely to result in performance degradation and hence a degradation in vibration isolation. A failure of this type is not expected to require a mission abort, since no interruption of the primary load path and no destructive resonances are likely.

In comparing the conventional UH-1H isolation system with the DAVI system, any differences in overall reliability would result primarily from differences in their respective parts. Since both the conventional and DAVI isolators use many common functional elements, there are actually only very slight differences in the two designs. Both employ rubber springs incorporated in fail-safe mounting arrangements so that there is little difference in this functional area. Both employ bearings; however, the increased number of bearings used in the DAVI isolator systems is expected to account for any differences in reliability that might exist between the two.

From a safety of flight viewpoint, the additional bearings of the DAVI system do not present a serious problem. Wear is the most probable cause of bearing failure, but with proper inspection and maintenance, very few serious bearing failures are likely to occur. However, when such failures do occur, the most likely effect on the DAVI system is degradation in vibration isolation, which does not represent a critical situation.

In summary, any decrease in isolation system reliability for the DAVI design compared to the conventional UH-1 isolator design, relative to mission performance, is expected to be minimal and should be no more than a minor offset compared to the gain in overall aircraft reliability resulting from reduced rotor induced vibration.

COST-EFFECTIVENESS

Vibration is known to be one of the major contributors to helicopter equipment failures, its impact varying with such factors as the type of equipment, the location of the equipment on the aircraft, and the method of isolation. Although the relationship between vibration and equipment failure has not been investigated thoroughly, one earlier study conducted for the Army by Sikorsky Aircraft, Reference 10, estimated that failure rates were reduced as much as 48 percent as a result of incorporating bifilar vibration absorbers on USAF H-3 helicopters.

Data recorded during the flight test of a DAVI-equipped UH-1H has shown that 2-per-rev vertical vibrations are reduced by 52 to 74 percent depending on location aboard the aircraft. If the correlation between vibration level and failure rate can be estimated for the various aircraft subsystems, as is assumed in this analysis and in Reference 10, then the experimentally measured vibration reductions for the DAVI-equipped UH-1 helicopter can be applied to UH-1 historical maintenance data to estimate corresponding reductions in aircraft failure rate and maintenance man-hour requirements at all maintenance levels. The resultant labor and repair parts dollar cost savings over the aircraft life cycle can also be estimated.

No cost categories other than maintenance labor and parts have been evaluated in the analysis. However, a number of other cost elements would be reduced indirectly by the potential improvement in reliability allowed by the DAVI system. These include depot pipeline spares cost, spares inventory cost, and spares packaging and shipping costs. Although consideration of these cost elements was not possible within the scope of the analysis, they are expected to have a significantly smaller impact on maintenance cost savings than labor and repair parts costs. An increase in aircraft availability can also be expected as a result of less frequent maintenance requirements. The cost savings associated with increased availability would also require a more detailed analysis than is possible at this time.

¹⁰ Veca

The failure rate reduction predicted for the UH-1H with a DAVI system installed is shown in Table 46. The percent reduction in vibration-induced failures for each of the fifteen subsystems of the UH-1H has been estimated from the DAVI/UH-1H flight test data. The data was recorded at five locations within the aircraft, and the vibration reduction indicated for each subsystem has been estimated based on the subsystem's location in the aircraft relative to the data recording stations. Only 2-per-rev vibration levels in the vertical plane have been considered in this analysis. Percentage reductions in vibration levels for the DAVI-equipped UH-1H compared to an unmodified UH-1H are average values calculated for aircraft gross weights of 8250 and 9500 pounds over the speed range from 20 to 110 knots.

The failure distribution for each UH-1H subsystem is given in Table 46 for six cause categories. This data has been extracted from 3-M maintenance records of U. S. Marine Corps UH-1E aircraft covering a total of 61,838 flight hours over a two-year period. As indicated in the footnotes of Table 46, the failure distributions for some of the failure cause categories were estimated using the same ratios from equivalent data on the H-2 aircraft. This was done only for those cause categories not reported in the UH-1E 3-M data. Only two of the six cause categories, failure of common hardware and primary failure, are considered to be influenced by vibration level. The remaining four categories are essentially independent of vibration and, therefore, cannot be reduced by reducing vibration.

Since the relationship between vibration and subsystem failures has never been thoroughly investigated, best-guess estimates of the percentages of vibration induced failures were made for the common hardware and primary failure categories for each UH-1H subsystem, and these are also shown in Table 46. The failure rate reduction for each of the two affected failure cause categories is calculated from the percent reduction in vibration-induced failures, the percent of total failures in each of the two categories, the percent of failures in each category that are vibration induced, and the total failure rate. The sum of the failure rate reductions for the two categories considered is the total failure rate reduction. For example, the reduction in airframe vibration induced failures determined from the DAVI/UH-1H flight test data is 61 percent. The failure rate reduction for common airframe hardware failures, $R_{CH/AF}$, is then

$$R_{CH/AF} = 0.61 \times (\% \text{ total failures in common hardware category}) \\ \times (\% \text{ common hardware failures that are vibration induced}) \\ \times (\text{total failure rate})$$

TABLE 46. ESTIMATED FAILURE RATE REDUCTION FOR DAVI-EQUIPPED UH-1H

Subsystem	% Reduction in Vibration Induced Failures(1)	UH-1 Failure Distribution - Percent							Estimated % Vibr. Induced			Total Failure Rate(2)	Failure Rate Reduction	Percent Reduction
		Maintenance or Operator Error(2)	Weather/Environment(2)	Failure of Common(3) Hardware(4)	Failure Due to External Causes(3)	Secondary Failure/Normal Wear(3)	Primary Failure(3)(4)	Common Hardware	Primary Failure					
Airframe	61	1.5	1.7	14.2	0.3	0.1	82.2	30	80	.0815	.0348	42.7		
Fuselage Compartment	52	2.7	2.6	12.3	-	0.1	82.3	30	10	.0106	.0007	6.4		
Landing Gear	60	2.0	0.9	6.0	0.4	0.7	90.0	30	10	.0087	.0006	6.9		
Flight Controls	60	3.1	2.9	5.3	-	-	88.7	30	50	.0635	.0175	27.6		
Power Plant	52	1.7	4.1	10.1	0.4	0.4	83.3	30	20	.0816	.0094	10.3		
Drives	46	3.7	3.9	13.2	0.3	-	78.9	30	20	.0422	.0024	5.8		
Electr. Power	64	0.6	3.6	10.4	-	-	85.4	30	30	.0257	.0057	18.4		
Lighting	52	1.2	1.0	7.3	0.3	-	90.2	30	90	.0335	.0173	51.6		
Hydraulic Power	60	2.9	7.7	11.9	-	-	77.5	30	50	.0168	.0043	25.4		
Fuel System	52	0.6	3.3	10.4	0.2	0.2	85.3	30	50	.0082	.0020	24.1		
Utilities	60	2.4	6.6	11.2	-	-	79.6	30	40	.0113	.0024	21.2		
Instruments	67	2.0	1.3	7.8	0.2	0.4	88.3	30	60	.0451	.0168	37.1		
ASE	67	-	2.8	2.8	-	0.5	93.9	30	70	.0012	.0005	44.7		
Communications	64	1.3	1.6	6.2	-	0.4	90.5	30	70	.1495	.0024	41.7		
Navigation	64	1.0	1.8	4.3	0.1	0.6	92.2	30	70	.0535	.0251	42.2		
										.6390	.1959	31.3		

(1) Based on UH-1/DAVI test data and relative location of subsystems on the aircraft.
 (2) Taken directly from 3-M data for the UH-1.
 (3) Estimates based on H-2 helicopter data.
 (4) Only failures assumed to be affected by vibration levels.

$$\begin{aligned} \text{or } R_{\text{CH/AF}} &= 0.61 \times 0.142 \times 0.30 \times 0.0815 \\ &= 0.0021 \text{ failures per flight hour} \end{aligned}$$

Similarly, the failure rate reduction for airframe primary failures, $R_{\text{PF/AF}}$, is

$$\begin{aligned} R_{\text{PF/AF}} &= 0.61 \times 0.822 \times 0.80 \times 0.0815 \\ &= 0.0327 \text{ failures per flight hour} \end{aligned}$$

The total airframe subsystem failure rate reduction, $R_{\text{T/AF}}$, is then

$$\begin{aligned} R_{\text{T/AF}} &= R_{\text{CH/AF}} + R_{\text{PF/AF}} = 0.0348 \text{ failures/FH, or, as the percent} \\ \text{reduction in airframe failure rate, } R_{\text{T/AF}}(\%) &= R_{\text{T/AF}}/0.0815 = 42.7\% \end{aligned}$$

The calculated total failure rate reductions are given in Table 46 for each UH-1H subsystem and for the aircraft as a whole, and they are also presented as the percent reduction in total failure rate. The overall failure rate reduction for the DAVI-equipped UH-1H aircraft is estimated to be 31.3 percent.

Note that in calculating the estimated reduction in failure rate for the drive subsystem, the failure rate reported in the UH-1E 3-M data for the main transmission was not included in the analysis since it is on the non-isolated side of the DAVI system. It should be noted also that the DAVI isolators are more complex in design than the standard UH-1H mounts. It appears likely, therefore, that the DAVI isolators would experience a higher failure rate, thereby counteracting the slight reduction in the drive subsystem failure rate estimated in Table 46. Although this possibility is recognized, the magnitude of the failure rate increase contributed by the DAVI isolators has not been evaluated.

The estimated labor cost savings resulting from the reduced failure rates are given in Table 47. Man-hour-per-flight-hour savings have been calculated from the maintenance action rate and the man-hours per action, also derived from the 3-M data, and the percent failure rate reduction shown in Table 46. The percent reduction calculated for on-aircraft failures has been applied directly to the repair frequency at the two higher maintenance levels. Dollar-per-flight-hour savings are calculated on the basis of \$11.50 per labor hour at the organizational and intermediate levels and \$12.75 per hour at the depot level. These rates were obtained by escalating estimated 1970 labor rates by 5 percent per year through 1975.

TABLE 47. ESTIMATED MAINTENANCE LABOR SAVINGS FOR DAVI-EQUIPPED UH-1H

Subsystem	Labor Rate: \$11.50/Hr										Labor Rate: \$11.50/Hr										Labor Rate: \$12.75/Hr									
	Organizational										Intermediate										Deyot									
	Maint. Action Rate(2)	Man-Hrs Per Action(2)	Reduction in Fail Rate	Man-Hrs/Flt-Hr	Savings Dollars/Flt-Hr	Maint. Action Rate(2)	Man-Hrs Per Action(2)	Reduction in Fail Rate	Man-Hrs/Flt-Hr	Savings Dollars/Flt-Hr	Maint. Action Rate(2)	Man-Hrs Per Action(2)	Reduction in Fail Rate	Man-Hrs/Flt-Hr	Savings Dollars/Flt-Hr	Maint. Action Rate(2)	Man-Hrs Per Action(3)	Reduction in Fail Rate	Man-Hrs/Flt-Hr	Savings Dollars/Flt-Hr	Total Dollar Savings/Flt-Hr									
																						0.0815	2.7	42.7	0.939	1.08	0.0015	30.7	42.7	0.197
Airframe Compartment	.0105	1.1	6.4	.0007	.01	.0010	2.5	6.4	.0002	0.01	.0010	2.5	6.4	.0002	0.01	.0010	2.5	6.4	.0002	0.01	0.01									
Landing Gear	.0087	4.4	6.9	.0026	.03	.0004	23.8	6.9	.0007	0.01	.0004	23.8	6.9	.0007	0.01	.0004	23.8	6.9	.0007	0.01	0.04									
Flight Controls	.0635	2.9	27.6	.0308	.58	.0125	1.1	27.6	.0038	.04	.0125	1.1	27.6	.0038	.04	.0125	1.1	27.6	.0038	.04	0.65									
Power Plant	.0816	2.5	10.3	.0210	.24	.0156	4.6	10.3	.0074	.09	.0156	4.6	10.3	.0074	.09	.0156	4.6	10.3	.0074	.09	0.34									
Drives	.0423	3.4	5.8	.0083	.10	.0106	1.5	5.8	.0009	.01	.0106	1.5	5.8	.0009	.01	.0106	1.5	5.8	.0009	.01	0.11									
Electrical Power	.0257	1.7	18.4	.0080	.09	.0159	9.4	18.4	.0275	.32	.0159	9.4	18.4	.0275	.32	.0159	9.4	18.4	.0275	.32	0.42									
Lighting	.0168	2.0	51.6	.0207	.24	.0109	2.4	51.6	.0135	.16	.0109	2.4	51.6	.0135	.16	.0109	2.4	51.6	.0135	.16	0.41									
Hydraulic Power	.0082	2.4	25.4	.0047	.05	.0009	2.2	25.4	.0002	.01	.0009	2.2	25.4	.0002	.01	.0009	2.2	25.4	.0002	.01	0.10									
Fuel System	.0113	2.4	21.2	.0057	.07	.0007	1.0	21.2	.0001	0.01	.0007	1.0	21.2	.0001	0.01	.0007	1.0	21.2	.0001	0.01	0.07									
Utilities	.0451	1.4	44.7	.0234	.27	.0189	1.0	44.7	.0070	.08	.0189	1.0	44.7	.0070	.08	.0189	1.0	44.7	.0070	.08	0.37									
Instruments	.0012	1.4	41.7	.0008	.01	.0008	1.6	41.7	.0006	.01	.0008	1.6	41.7	.0006	.01	.0008	1.6	41.7	.0006	.01	0.02									
ASE	.1495	1.5	41.7	.0935	1.08	.1134	3.3	41.7	1.1560	1.79	.1134	3.3	41.7	1.1560	1.79	.1134	3.3	41.7	1.1560	1.79	3.59									
Communications	.0595	1.6	42.2	.0402	.46	.0387	3.3	42.2	1.0539	1.62	.0387	3.3	42.2	1.0539	1.62	.0387	3.3	42.2	1.0539	1.62	3.59									
Navigation				.3828	4.41																1.43									
																						8.94								

(1) Based on UH-1/DAVI test data and relative location of subsystems on the aircraft.

(2) Taken directly from 3-M data for the UH-1.

(3) Estimates based on H-2 helicopter data.

(4) Only failures assumed to be affected by vibration levels.

As an example, the labor cost savings at the organizational level, $\Delta C_{OL/AF}$, resulting from reduced airframe maintenance is

$$\Delta C_{OL/AF} = (\text{Maintenance action rate}) \times (\text{Man-hours per action}) \\ \times R_{T/AF}(\%) \times (\text{Organizational labor rate})$$

or

$$\Delta C_{OL/AF} = .0815 \times 2.7 \times .427 \times \$11.50/\text{hr} \\ = \$1.08 \text{ per flight hour.}$$

The airframe labor cost savings at the intermediate level, $\Delta C_{IL/AF}$, is

$$\Delta C_{IL/AF} = .0015 \times 30.7 \times .427 \times \$11.50/\text{hr} \\ = \$0.23 \text{ per flight-hour}$$

Since the airframe cost savings at the depot level, $\Delta C_{DL/AF}$, is negligible,

$$\Delta C_{DL/AF} = 0.$$

The total airframe labor cost savings for all maintenance levels is

$$\Delta C_{TL/AF} = \Delta C_{OL/AF} + \Delta C_{IL/AF} + \Delta C_{DL/AF} \\ = 1.08 + 0.23 + 0 = \$1.31 \text{ per flight hour}$$

The overall labor cost saving for the DAVI-equipped UH-1H has been estimated to be \$8.94 per flight hour in 1975 dollars, as shown in Table 47.

An estimate of repair parts savings can be made based on the UH-1H parts usage rate and the estimated overall percent failure rate reduction. U. S. Army data for Republic of Vietnam experience for various helicopters indicates a repair parts usage rate of \$132 per flight hour for the UH-1H in field operations, Reference 22. For the 31.3-percent failure rate reduction given in Table 46, the estimated repair parts savings, excluding the cost of repairable end items, is \$41.32 per flight hour. The total maintenance labor and repair parts savings for a DAVI-equipped UH-1H is, therefore, \$50.26 per flight hour.

Based on an average utilization of 20 flight hours per aircraft per month, the annual maintenance labor and repair parts saving would be 12 million dollars per 1000 aircraft; 9.9 million dollars of this 12 million is in repair parts saving.

²² U. S. Army Aviation Planning Manual, FM 101-20, August 1968.

WEIGHT

In this program to determine the feasibility of DAVI rotor isolation, finding the minimum weight in the DAVI isolation system was not a primary design objective. The following discussion develops a weight prognosis for an optimized system.

Table 48 gives the weight breakdown of the DAVI system and the weight removed from the standard system. The weight is given for the isolators, the structural modifications for the installation of the isolators, and the controls. The weight penalty in the controls is primarily due to the forward and aft beams for the support of the controls. These beams were designed for ease of fabrication rather than minimum weight.

Table 48 shows that the DAVI system and the structural modification weighed 2.31 percent of the 6600-pound design gross weight of the UH-1H helicopter, and the total system, including the control modification, weighed 3.15 percent of the 6600-pound vehicle.

Although weight could have been saved in this prototype DAVI system with a more efficient design, the greatest reduction could be achieved by a change in the concept of the existing design. The present lift-link DAVI inertia bars weigh 24.93 pounds. This compares to 10.81 pounds for the inertia bar weight of the transmission DAVI. The spring rates of these two DAVIs are essentially the same, and the increased weight requirements of the inertia bar of the lift-link DAVI are due to the small cg distance of the bar from the pivots. By incorporating the spring rate of the lift-link DAVI in the transmission DAVIs to maintain the present overall vertical spring rate, the lift-link DAVI could be eliminated. The inertia bar weight of the transmission DAVI would become 13.51 pounds. This four-point DAVI system would weigh 113.32 pounds. Subtracting the weight of the standard system, the weight increase would be 84.05 pounds.

Based upon these calculations and concepts for further refinements, an optimized four-point DAVI isolation system for the UH-1 helicopter, not requiring structural or control system modifications, could be designed for 84 pounds or 1.27 percent of the design gross weight.

For other helicopter configurations of higher gross weights and/or higher n-per-rev predominant frequencies, in which lower inertia weights could be utilized to obtain the proper antiresonant frequencies, lower percentages of the design gross weights would be feasible.

TABLE 48. ISOLATION SYSTEM WEIGHT

Number	Item	Unit Weight	Weight
DAVI ISOLATION SYSTEM			
4	Transmission-Mount DAVI	29.69	118.76
1	Lift-Link DAVI	36.36	36.36
Subtotal			155.12
STANDARD ISOLATION SYSTEM			
1	Lift-Link	2.13	2.13
4	Transmission Mounts	4.41	17.64
1	Fifth Mount	4.25	4.25
1	Support Beam, Fifth-Mount	5.25	5.25
Subtotal			29.27
Net Weight Increase, DAVI Isolation System			125.85
STRUCTURAL MODIFICATIONS			
Structure Added			53.27
Structure Removed			26.42
Net Weight Increase, Structural Modifications			26.85
CONTROL MODIFICATIONS			
Controls Added			
Fwd, and Aft Beam			43.34
Rods, Cranks, and Idlers			28.42
Subtotal			71.76
Controls Removed			16.83
Net Weight Increase, Control Modifications			54.93
Total Weight Increase, Isolation System, Structural and Control System Modifications			207.63

CONCLUSIONS

From the results of this flight test program on a DAVI-modified vehicle, in which substantial reduction in vibration level was obtained as compared to a standard UH-1H helicopter, it is concluded that:

1. Rotor isolation using the Dynamic Antiresonant Vibration Isolator reduced vibration significantly, which can be projected into significant operational cost savings. In addition, the large reduction in vibration was attained on a helicopter that already had a conventional vibration reduction system installed.
2. Flying qualities of the UH-1H helicopter were not affected by DAVI rotor isolation.
3. Excessive deflection did not occur and misalignment of the engine drive coupling is not a problem.
4. A DAVI isolation system can be designed to insure freedom from mechanical instability and to insure engine-rotor torsional compatibility.
5. Damping in the DAVI isolation must be low to insure low vibration levels.
6. A DAVI rotor isolation system can be designed to be 1.27 percent or less of the gross weight of the helicopter.
7. Reduction in operational costs in the field can be achieved because of the low vibration levels.

RECOMMENDATIONS

Because of the success of this program, this contractor recommends a continued effort in research and development for rotor isolation and related areas. These recommendations are:

1. Flight testing be continued on the existing modified vehicle to determine improvements in design and to achieve even lower levels of vibration. This flight test program should include at least:
 - (a) The determination of the effects of the vibratory forces from the horizontal stabilizer on the vibration level of the modified vehicle.
 - (b) An assessment of the value of a four-point DAVI system, where lift-link DAVI is not used, for reducing vibration levels.
 - (c) The reorientation of the standard friction dampers to a longitudinal direction to determine the effects on the flying qualities and the vibration levels of the modified vehicle.
2. Several UH-1H vehicles should have the DAVI rotor isolation system installed for evaluation by Army personnel in the field. This evaluation should concentrate on documenting the effects of reducing vibration on pilot fatigue and R&M.
3. Although not necessarily associated with rotor isolation, the present DAVI-modified helicopter is an ideal vehicle to determine the effects of hub impedance on rotor loads. It is therefore recommended that several settings of the tuning weights be done and a shake test performed to determine the hub impedance with these known impedances. A flight test can be done to determine the effects of hub impedance on rotor loads.
4. Because of the wide use of elastomers for isolation (as in both DAVI and standard systems) and in the rotor heads for effective hinges, a better understanding of the damping, and the static and dynamic spring of elastomers is required. It is highly recommended that further research be done to determine these characteristics and that a design manual or charts be developed.

REFERENCES

1. Theobald and Jones, ISOLATION OF HELICOPTER ROTOR VIBRATION FORCES FROM THE FUSELAGE, Kaman Aircraft, Bloomfield, CT, WADC Technical Report 57-404, Wright Air Development Center, Dayton, OH, September 1957.
2. Crede and Cavanaugh, FEASIBILITY STUDY OF AN ACTIVE VIBRATION ISOLATOR FOR A HELICOPTER ROTOR, Barry Wright Corp., WADC Technical Report 58-163, Wright Air Development Center, Dayton, OH, October 1958.
3. Smollen, Marshall and Gabel, A SERVO-CONTROLLED ROTOR VIBRATION ISOLATION SYSTEM FOR THE REDUCTION OF HELICOPTER VIBRATION, Institute of Aerospace Sciences Paper No. 62-34, New York, NY, January 1962.
4. Schuett, PASSIVE HELICOPTER ROTOR ISOLATION USING THE KAMAN DYNAMIC ANTIRESONANT VIBRATION ISOLATOR (DAVI), USAAMRDL Technical Report 68-46, Eustis Directorate, U. S. Army Air Mobility Research and Development Laboratory, Fort Eustis, VA, December 1968, AD 687324.
5. Calcaterra and Schubert, ISOLATION OF HELICOPTER ROTOR-INDUCED VIBRATIONS USING ACTIVE ELEMENTS, USAAMRDL Technical Report 69-8, Eustis Directorate, U. S. Army Air Mobility Research and Development Laboratory, Fort Eustis, VA, June 1959, AD 859806.
6. Jones, A FULL-SCALE EXPERIMENTAL FEASIBILITY STUDY OF HELICOPTER ROTOR ISOLATION USING THE DYNAMIC ANTIRESONANT VIBRATION ISOLATOR, USAAMRDL Technical Report 71-17, Eustis Directorate, U. S. Army Air Mobility Research and Development Laboratory, Fort Eustis, VA, June 1971, AD 729317.
7. von Hardenberg and Saltanis, GROUND TEST EVALUATION OF THE SIKORSKY ACTIVE TRANSMISSION ISOLATION SYSTEM, USAAMRDL Technical Report 71-38, Eustis Directorate, U. S. Army Air Mobility Research and Development Laboratory, Fort Eustis, VA, September 1971, AD 736347.
8. Shipman, NODALIZATION APPLIED TO HELICOPTERS, Society of Automotive Engineers Paper Number 730893, Presented at National Aerospace Engineering and Manufacturing Meeting, Los Angeles, California, October 1973.
9. Ellis, Diamond and Fay, DESIGN DEVELOPMENT AND TESTING OF THE BOEING VERTOL/YUH-61A, American Helicopter Society Paper Number 1010, Presented at 32nd Annual National Forum, Washington, D.C., May 1976.

REFERENCES (Continued)

10. Veca, VIBRATION EFFECTS ON HELICOPTER RELIABILITY AND MAINTAINABILITY, Sikorsky Aircraft; USAAMRDL Technical Report 73-11, U. S. Army Air Mobility Research and Development Laboratory, Fort Eustis, VA, April 1973, AD 766307.
11. EXECUTIVE SUMMARY REPORT - UH-1H ASSESSMENT AND COMPARATIVE FLEET EVALUATION, USAAVSCOM Technical Report 75-3, U. S. Army Aviation Systems Command, St. Louis, MO, April 1975.
12. Bill and Maier, UH-1H HELICOPTER, BASELINE FLIGHT VIBRATION - SUMMARY OF VIBRATION DATA, Kaman Report SMR-1006, Kaman Aerospace Corporation, Bloomfield, CT, October 1972.
13. Bill, UH-1H DAVI MODIFIED HELICOPTER, FLIGHT VIBRATION - SUMMARY OF VIBRATION DATA, Kaman Report SMR-1053, Kaman Aerospace Corporation, Bloomfield, CT, September 1975.
14. Maloney and Akeley, DESIGN STUDY OF REPAIRABLE MAIN ROTOR BLADES, Kaman Aerospace Corporation; USAAMRDL Technical Report 72-12, U. S. Army Air Mobility Research and Development Laboratory, Fort Eustis, VA, July 1972, AD 749283.
15. FUSELAGE STRUCTURAL ANALYSIS, VOLUMES I THROUGH IV, Bell Helicopter Company, Fort Worth, TX, Bell Report 205-009-007, 28 February 1969.
16. EXTERNAL DESIGN LOADS, VOLUME III, Bell Helicopter Company, Fort Worth, TX, Bell Report 205-099-006, 6 March 1969.
17. Tarricone, Mank and Hardersen, STRESS ANALYSIS: ISOLATION SYSTEM/ AIRFRAME AND CONTROL SYSTEM MODIFICATIONS FOR THE BELL UH-1H ROTOR ISOLATION PROGRAM, Kaman Aerospace Corporation, Bloomfield, CT, Kaman Report S-119, September 1973.
18. Fitzpatrick, FLYING QUALITIES COMPARISON OF UH-1H WITH TWO ROTOR ISOLATION SYSTEMS, Kaman Aerospace Corporation, Bloomfield, CT, Kaman Report P-66, September 1974.
19. Luff, TEST RESULTS, FATIGUE TEST OF DAVI ROTOR ISOLATION MOUNTS FOR THE ARMY MODEL UH-1H HELICOPTER, Kaman Aerospace Corporation, Bloomfield, CT, Kaman Report T-585-1, August 1975.
20. Luff, TEST RESULTS - STATIC PROOF LOAD TEST OF A DAVI MODIFIED UH-1H HELICOPTER, Kaman Aerospace Corporation, Bloomfield, CT, Kaman Report T-626-1, April 1975.

REFERENCES (Continued)

21. Coleman and Feingold, THEORY OF SELF-EXCITED MECHANICAL OSCILLATIONS OF HELICOPTER ROTORS WITH HINGED BLADES, NACA TN 3844, Langley Aeronautical Laboratory, Langley Field, VA, February 1957.
22. U. S. Army Aviation Planning Manual, FM 101-20, August 1968.

78