

AD-A051 524

NAVY ELECTRONICS LAB SAN DIEGO CALIF
SONAR RAW DATA RECORDING SYSTEM.(U)
JUN 55 F A STEINER
NEL-TM-117

F/G 17/1

UNCLASSIFIED

NL

1 of 1
AD
A051524



END
DATE
FILMED
4 -78
DDC

~~CONFIDENTIAL~~
UNCLASSIFIED

MOST Project - 3

NE 050632

SUBTASK 1

PROBLEM NEL E3-1a

technical memorandum no. 117

4040

AD A 051524

11
16 June 55

14
NEL-TM-117

9
Technical memo

1
D D C
REPRODUCED
MAR 21 1978
REGULATED
A

6
SONAR RAW DATA RECORDING SYSTEM.

10
F. A. Steiner

2123

12
24 p1

AD No. 117
DDC FILE COPY

This document contains information affecting the national defense of the United States within the meaning of the Espionage Laws, Title 18, U.S.C. Sections 793 and 794, the transmission or the revelation of its contents in any manner to an unauthorized person, is prohibited by law. Extracts from this publication may be made to facilitate the preparation of other Department of Defense Publications. It is forbidden to make extracts for any other purpose without the specific approval of the Chief of the Bureau of Ships, except as provided for in the U.S. Navy Security Manual for Classified Matter.

U.S. Navy Electronics Laboratory, San Diego 52, California

650218-0171

DISTRIBUTION STATEMENT A
Approved for public release;
Distribution Unlimited

~~CONFIDENTIAL~~
UNCLASSIFIED

DOWNGRADED AT 3-YEAR INTERVALS 23
DECLASSIFIED AFTER 12 YEARS
DOD DIR 5200.10

253 550

alt

117

AP-13

UNCLASSIFIED

SONAR RAW DATA RECORDING SYSTEM

By
F. A. Steiner

INTRODUCTION

ADDITIONAL FOR	WRITE SECTION	<input checked="" type="checkbox"/>	<input type="checkbox"/>	<input type="checkbox"/>
RTIS	BUC	JUSTIFICATION	DISTRIBUTION AVAILABILITY CODES	
UNAR-ORIGINEE			DIRL AVAIL. and or SPECIAL	
see Steiner on file			A	

This memorandum describes a proposed system for the recording and playback of sonar data. This proposal has grown out of instrumentation requirements for NEL studies on sonar target classification cues and is being published at this time to make it available to NEL personnel developing sonar raw data recording equipment and to the BUSHIPS Interlaboratory Committee on Sonar Raw Data Recording. Further distribution outside this Laboratory is not anticipated.

A recorder-playback system capable of recording sonar signals and associated data for subsequent playback into sonar receiving equipment is urgently needed for sonar research, development, evaluation, and training.* Equipment for such recording should be capable of operation on as many of the sonar systems currently in use by the Fleet as is possible and provide as complete data as is practicable. Wide dynamic range, frequency stability, gain stability, and versatility are the most significant design criteria.

Equipment for recording sonar signals should obtain the signals in as raw form as practical, i.e., as soon after transduction as possible, to prevent prejudice of data by shipboard sonar and operator. Equipment should retain as much doppler information as possible for application to sonar processing equipments such as the RRI and ACIM now under development.

DESIGN CRITERIA

High frequency stability to retain doppler information is necessary in that doppler frequency shifts of the order of 5 cps are considered significant. Dynamic range approaching 120 decibels will be necessary, but since recorders are limited to a range of 50 to 70 decibels, compression of early reverberation will be achieved by time varied gain amplifiers. Compression on the order of 40 to 70 decibels can be achieved. The sonars for which this system is designed to operate should include SQS-4, SQS-10, SQS-11, QHB and QJB,

* See R.S.Gales "Requirements for the Recording of Sonar Data," Proc. of Dept. of Defense Symposium on Magnetic Recording, Fifth Symposium on Acoustics in Air, Conf. Session held 14 Oct. 1953, 31 Jul. 1954

UNCLASSIFIED

~~SECRET~~
UNCLASSIFIED

whose operating frequencies (Table 1) are between 14 and 25.5 kilocycles and whose video azimuth sweep rates in the case of the scanning sonars are 29.2 and 150 cycles per second. As sweep stability has been found to be a problem, sweep will be recorded on an independent channel, in order to get adequate bandwidth and amplitude stability in the order of .1%.

<u>SONAR</u>	<u>PRIMARY FREQUENCY</u>	<u>BANDWIDTH</u>	<u>SWEEP FREQUENCY</u>	<u>CHANNELS</u>
SQS 4	14 kilocycles	.72 kilocycles	150 cycles/second	3
SQS 10	20 "	1.05 "	150 "	3
SQS 11	25.5 "	1.2 "	150 "	3
QHB a	25.5 "	1.0 "	29.2 "	2
QHB c	25.5 "	1.2 "	150 "	2
QHB d	20 "	1.05 "	150 "	2
QHB 4	25.5 "	1.0 "	29.2 "	2
QJB	24 "	3.0 "	-	2

Table 1

Other data to be recorded will include commentary on sonar operation, audio train signal, gyro compass signal, log signal, and their reference.

FUNCTIONAL DESCRIPTION

Recording System

A functional block diagram of the recording system based on spectral assignments shown in Fig. 1, is shown in Fig. 3. The sonar frequency signals from respective scanning switches are fed to bridging pre-amplifiers (1) to provide medium level at low impedance. Band pass filters (2), and variable attenuators (3) control bandwidth and overall level. The signal is then fed to linear mixers (4) in which a pilot tone (5) is introduced to provide a reference for subsequent compression-expansion operations. This composite signal is then fed to the variable gain amplifier (6) controlled by control signal generator (7). This control signal follows the necessary time function to provide proper compression of the high amplitude reverberation,

UNCLASSIFIED ~~SECRET~~

CONFIDENTIAL

and is initiated by the keying pulse of the sonar. The compressed composite signal is now fed to a threshold amplifier (8), whose function is to indicate to the operator when signals exceed the maximum usable level. In the case of the sonar audio recording channel, a transfer switch is introduced following the threshold amplifier and will, during the time of the transmitted signal, feed that signal through fixed attenuator (11), variable attenuator (3), and pilot tone mixer (4). This transfer switch (10) must act sufficiently slowly that interruptions in the pilot tone can be detected later to key the monitor oscilloscope sweep. The sonar frequency signals in all channels are fed at this point to heterodyne mixers (12) and mixed with heterodyne oscillator signals to be described later, fed to band pass filters (16), amplifiers (17), and normaled to blanking switches (21) in the case of video channels, and directly in the case of the audio channel to mixers (22) where synchro information on high frequency carriers is introduced. The signal is then fed to limiters (23) and thence to recorder channels.

With respect to the heterodyne oscillator signal fed to heterodyne mixers (12), two options appear, one of which provides frequency stabilization which will in part cancel the speed variations of the recorder. This stabilization technique is discussed in detail on page 7. In the case where the stabilization is not required, the translator oscillator (13), whose frequency differs from the sonar primary frequency by 5 kilocycles, is fed to the heterodyne mixers (12) directly. However, in the case where stabilization is desired, this oscillator provides a signal whose Nth harmonic differs from the sonar frequency by approximately 5 kilocycles (see Fig. 4), but whose nth harmonic is approximately 10 kilocycles. This oscillator is fed to harmonic generator (14) and through band pass filters (15, 19) in order to provide these harmonics. The nth

CONFIDENTIAL

harmonic, being near 10 kilocycles, is mixed linearly in optional linear mixers (18), following amplifiers (17) and fed through band pass filters (20) to mixers (22).

Audio train, gyro compass, log, and reference signals are introduced at mixers (22). These are provided as follows: train signal as synchro orders at 1x and 36x are fed to synchro repeaters (37) and mechanically coupled to 1x and 11x resolvers (38), whose output is phase referenced to the gyro power signal. Likewise, the gyro compass signal is so resolved. The log signal is provided as 1x synchro order fed to synchro repeater mechanically coupled to 1x resolver in the same manner. These 1x and 11x signals and their reference are fed to 6 variable attenuators (39) and heterodyne mixers (40) fed from master oscillators (41) as shown in the block diagram. The signals are then band passed and fed in pairs to mixers (22).

A special channel for video sweep and commentary is provided. The video sweep signal on one branch of the three phase signal from the sweep generator is fed to the variable attenuator (24) and is fed to the mixing system together with the commentary as provided from microphone (25) audio pre-amplifier (26), band pass filter (27), variable attenuator (28), and amplifier (29). (Option A) If the sweep frequency is within the response range of the recorder these signals may be simply mixed linearly in mixer (32) and recorded directly. If, however, the sweep rate is too low for direct recording, it can be used (Option B) to frequency modulate (31) a carrier in the region above voice frequencies (4000 to 15,000) and then mixed. If greater stability is necessary the deviation due to the recording medium can be reduced by (Option C) controlling the frequency modulator (31) by an oscillator (33) and a harmonic of this oscillator also mixed in mixer (40)

CONFIDENTIAL

to be used for frequency control at playback. Pulse position modulation* (Option D) has been proposed for this channel, and its properties should be investigated.

The recorder proposed is an Ampex 307-4 with one possible modification. In case the pulse position modulation option is used, where the tape must be saturated, the bias supplied to the 4th channel recording head must be eliminated. If direct recording of the sweep is used, equalization in this channel down to 150 cps will be necessary. Otherwise, the recorder is as supplied by the manufacturer.

Playback System

The playback system is shown in block diagram form in Fig. 4. At the playback outputs of the recorder, band pass filters (43, 44, 45) divide the signals according to their respective frequency channels and in the case of frequency stabilization, the additional band pass filters are required. (46) The signals from band pass filters (43, 44) being those at the upper end of the spectrum which were the carrier channels of synchro information, are amplitude detected (47), low passed (48), amplified (50), and fed to servo motors (51) which are mechanically coupled to synchro generators (52) which restore the audio train, gyro compass, and log repeater synchro orders. Band pass filters (45) separate the sonar information channels and are fed to amplifiers (53) and heterodyne mixers (54), where sonar frequency is restored in the following manner: In the case where the frequency stabilization option was not used, the master oscillator (55) provides a signal at a frequency equal to the sonar frequency plus

* The pulse phase system of magnetic recording - Stancil Hoffman Corporation

CONFIDENTIAL

5 kilocycles for heterodyning the 5 KC recorded signal to restore the original sonar frequency. In the case of the frequency stabilization option, the output of band pass filter (46) is fed to a frequency divider (56) through band pass filter (57) to an heterodyne mixer (58), mixed with signal from master oscillator (59) whose frequency is that of the former sonar principal frequency, and a difference frequency is fed through band pass filter (60) to heterodyne mixer (54), restoring the original sonar frequency. This signal is band passed through filters (61, 62) to separate the pilot tone from the sonar information signal. The pilot tone from band pass filter (62) is amplitude detected in detector (63) and fed to the variable gain amplifier (64) as a control signal to restore the original dynamic range. In the case of the sonar audio channel, the discontinuities in the pilot tone are detected by a differentiator (65) and fed to a trigger circuit, which operates a transfer switch or gate (66) to provide the transmitted signal to an oscilloscope for monitoring. The output of the variable gain amplifier as provided to transfer switch (66) during the remainder of the time is fed through band pass filter (67) and amplifier (68) into the sonar receiver at the time of playback. The video channels are likewise fed from the variable gain amplifiers (64) through band pass filters (67) and amplifiers (68) to their respective video receiver channels.

The treatment of video sweep and commentary at the time of playback again has four options. The sweep and commentary channels are separated and fed respectively to a sweep generator (80) through variable attenuator (79) and to power amplifier (82) and loudspeaker (83), thru variable attenuator (81). The separation is accomplished in the mixed case (Option A) by band pass filters (70, 71), in the case of frequency modulation (Option B) by band pass filters (70, 71) and the sweep fed through

CONFIDENTIAL

a frequency discriminator (72); in the case of controlled frequency modulation (Option C) by band pass filters (70, 71, 73) with the frequency control signal from band pass filter (73) to a frequency dividing binary scaler (74) through band pass filter (75) and mixed (76) with the output of oscillator (77) to provide the frequency control in frequency discriminator (72A) through band pass filters (70, 78); in the case of Pulse Position modulation (Option D) the signals are separated in the pulse position demodulator (69).

The frequency stabilization technique

The frequency stabilization option mentioned briefly earlier is described in detail in the following. In order that signal frequency modulation induced by wow and flutter of tape recorders may be effectively cancelled, a technique has been devised whereby the frequency variations due to these phenomena are eliminated at the fundamental frequency and are arithmetically proportional to the deviations from the fundamental in the wide band. To do this, the sonar frequency is translated to a carrier at approximately 5 kilocycles by an oscillator whose frequency is an integral multiple or sub-multiple of this number, approximately 5 kilocycles. In this manner a frequency control signal, which is an exact harmonic of the principal frequency recorded, can be also recorded and used to provide a beat frequency at playback, whose frequency deviations are identical to, but in a negative sense, from those of the principal frequency. (See Fig. 2). The second harmonic is used in this case because simple binary scalars are available, which have high dependability and stability and can be used to provide halved frequencies. The fact that the bandwidth of the signal recorded does not exceed $2\frac{1}{2}$ kilocycles makes isolation of the principal signal and its second harmonic, that is, 5 kilocycles plus or minus $2\frac{1}{2}$ kilocycles and 10 kilocycles, both practical and effective.

CONFIDENTIAL

The provision of the 5 kilocycle signal and the properly related harmonic is accomplished by providing a master oscillator and harmonic generator through band pass filters, one feeding the heterodyne mixer a frequency differing from the principal frequency by approximately 5 kilocycles, and the other feeding the linear mixer later in the circuit with the 10 kilocycle or second harmonic signal. This provides two signals on the same channel harmonically related as nearly as possible, one of which contains frequency deviation carrying the doppler, as well as amplitude information present in the transducer output. These two signals are fed to the recorder where speed changes (from wow and flutter) introduce proportional frequency changes in each signal. The frequency control signal, being twice the frequency of the principal information signal but with very narrow bandwidth, can be simply divided by a binary scaler, providing a signal at the same frequency as the principal signal, and with identical frequency deviation due to speed changes. The frequency control signal is fed to another heterodyne mixer together with the output of an oscillator set to the original sonar primary frequency, providing a difference signal. This difference signal has deviations inversely proportional to the changes in speed and when mixed with the principal signal in a third heterodyne mixer, provides the original sonar frequency with deviations due to speed changes cancelled exactly and doppler deviations increased in proportion to such speed changes.

This will be a powerful tool to the development of high frequency stability if such is necessary. Since the speed stability of tape recorders on an unstable platform is not yet thoroughly determined, it is currently unknown if such techniques must be incorporated into this sonar raw data recording system.

ELEMENTARY DESCRIPTION

Recording

1. Pre-amplifiers providing low noise and wide dynamic range are used to bridge the scanning switch outputs and provide medium signal level for transmission to subsequent equipment. Input impedance must be high enough not to load the scanning switch circuits and load impedance should be 600 ohms to feed band pass filters. Input signals have a dynamic range of 120 decibels above a few (1 to 10) microvolts noise level. Gain must be sufficient to minimize effects of noise pickup in subsequent circuits, and the pass band is 10 to 30 kilocycles.
2. Band pass filters at 600 ohms eliminate noise outside the pass band of the pre-amplifiers and should provide optimum loading.
3. Variable attenuators in the form of 600 ohm T-pads or similar units are used to provide signal level control for all subsequent equipments in the frequency range of 10 to 30 kilocycles.
4. Pilot tone mixers should provide linear mixing with a minimum of inter-modulation products. The input impedance should be 600 ohms for the sonar signal channel and as required for the pilot generator and load as required for the variable gain amplifier.
5. Pilot tone generator is an oscillator whose frequency is 1000 cycles removed from the translator oscillator frequency to provide a 1 kilocycle pilot tone. This should be a plug-in unit since the translator oscillator frequency varies for different sonars. (All other units described heretofore are universal to all sonars discussed in this paper.)
6. Variable gain amplifiers are provided to give sufficient compression of dynamic range that recorders with 50 decibel range can handle the

CONFIDENTIAL

output signals. The gain is time varied according to a capacitor resistor decay as found in the following unit.

7. Control signal generator provides a signal as a function of time after transmitted or keying pulse to decrease the gain of variable gain amplifiers as much as 40 decibels at the time of transmitted pulse and approaching normal gain in an adjustable time of the order of 1 to 5 seconds.
8. The threshold amplifier is a device which provides a signal to an indicator circuit at such times as the principal signal excursion exceeds pre-set thresholds.
9. Indicator for above amplifier in the form of meter or lamp to indicate to operator signals approaching within safe limits of maximum, and in excess of maximum modulation.
10. Transfer switch which connects transmitted signal to input of heterodyne mixer during the time transmitted signal is present.
11. Fixed attenuator to provide transmitted signal at medium level for application to heterodyne mixers.
12. Heterodyne mixer accepting sonar signal and signal from band pass filter (15) to produce approximately 5 kilocycle signal for recording.
13. Translator oscillator is part of a plug-in unit providing heterodyne beat frequency (See Fig. 2)
14. Harmonic generator used in conjunction with above oscillator when frequency stabilization option is used.
15. Band pass filter in conjunction with frequency stabilization option to provide proper harmonic for heterodyne mixer (12).
16. The band pass filter to eliminate higher intermodulation products from heterodyne mixer.
17. Amplifier to compensate for the attenuation of band pass filters and

CONFIDENTIAL

other elements and to provide isolation

18. Linear mixer to mix the output of band pass filter (20) with heterodyned sonar signal from amplifier (17).
19. Band pass filter to extract the proper harmonic of translator oscillator for frequency control system. Pass band of approximately 200 cycles.
20. Band pass filter to eliminate intermodulation products from output of mixer (18). (Plug in.)
21. Blanking switch shorts out the output from video channels during transmitted signal.
22. Linear mixer for the addition of servo information to the three sonar information channels.
23. Limiter to limit excursion of heterodyned sonar signal within the dynamic range of the recorder.
24. Variable attenuator on one channel of the video sweep as provided to the deflection coils for the overall control of the level in this channel.
25. Microphone for pickup of commentary.
26. Audio pre-amplifier.
27. Band pass filter for voice frequencies 300 to 3000 cps impedance as required.
28. Variable attenuator to control level of commentary signal.
29. Amplifier to provide necessary level to modulator or mixer for recording of commentary.
30. Pulse phase modulator as described by Mr. George W. Downes, in his paper "The pulse phase system of magnetic recording," published by Stancil Hoffman Corporation, if adequate.
31. Frequency modulator for video sweep signal if pulse position modulation is found inadequate.

CONFIDENTIAL

32. Linear mixer for combination of frequency modulated video sweep signal and commentary for the recorder.
33. Reference oscillator for frequency control if necessary in the video sweep frequency modulation system.
34. Harmonic generator for frequency stabilization of video sweep recording channel.
35. Band pass filter to select proper harmonic from (34) for frequency modulator control.
36. Same as 35 for playback control.
37. Synchro repeaters accepting servo command signals and converting them to shaft position.
38. Resolvers, accepting servo shaft position and converting to phase modulation of 60 cycle reference signal.
39. Variable attenuator for control of level of 60 cycle resolver signal.
- 40A. Heterodyne mixers accepting 60 cycle resolver signal and 12 kilocycle signal from oscillator (41A) to provide amplitude modulated carrier for addition to sonar signal channels at mixer (22).
- 40B. Heterodyne mixer as above with the exception that the oscillator signal is 14 kilocycles.
- 41A. 12 kilocycle oscillator to provide carrier for heterodyne mixers (40A).
- 41B. 14 kilocycle oscillator to provide carrier for heterodyne mixers (40B).
- 42A. Band pass filters 200 cycles wide centered at 12 kilocycles.
- 42B. Band pass filters 200 cycles wide centered at 14 kilocycles.

Playback

43. Band pass filters 200 cycles wide centered at 12 kilocycles to separate 60 cycle phase modulated servo information.
44. Same as above except centered at 12 kilocycles.
45. Band pass filters from 300 to 8000 cps to separate mixed sonar infor-

CONFIDENTIAL

- mation signal and pilot tone from other circuits on the same channel.
46. Band pass filters 2 kilocycles wide centered at 10 kilocycles to separate frequency control signal from other signals on the same channel.
 47. Amplitude detector for 60 cycle phase modulated servo information.
 48. 60 cycle low pass filter.
 49. Variable attenuators for the control of signal level through amplifiers (50) to servo motors (51).
 50. Amplifiers provide sufficient power for 60 cycle servo motors (51).
 51. Servo motors to provide shaft position from phase modulated synchro information channels to synchro generators.
 52. Synchro generators to reproduce synchro orders for sonar equipment.
 53. Amplifiers to provide high signal level necessary for heterodyne mixer operation.
 54. Heterodyne mixer to restore original sonar frequency signals from the translated carrier.
 55. Master oscillator to provide signal necessary for above translation if no frequency stabilization is used.
 56. Frequency divider to restore fundamental from recorded second harmonic of control frequency.
 57. Band pass filter to achieve approximate sine wave form to above signal.
 58. Heterodyne mixers receiving 5 kilocycle frequency stabilization signal from band pass filters (57) and master control frequency from oscillator (59) to provide difference frequency 5 kilocycles below principal sonar frequency.
 59. Master oscillator operating at sonar primary frequency. (Plug in unit)

CONFIDENTIAL

60. Band pass filter centered 5 kilocycles below sonar primary frequency to eliminate side bands from beat frequency signal in restoration by addition in heterodyne mixer (54) of original sonar signal. (Plug in unit)
61. Band pass filter centered at sonar primary frequency and 600 cycles wide. (Plug in unit)
62. Band pass filter centered at 1 kilocycle 100 cycles wide to separate pilot tone.
63. Amplitude detector to provide gain control signal from pilot tone amplitude.
64. Variable gain amplifier whose gain is determined as an inverse function of pilot tone amplitude.
65. Differentiating amplifier in sonar audio channel only to indicate absence of pilot tone for use by transfer switch to separate transmitted pulse and to provide keying pulse.
66. Transfer switch for output of variable gain amplifier from playback circuit to oscilloscope for monitoring transmitted signal, pulse, and wave form.
67. Band pass filter to eliminate harmonic distortion products from variable gain amplifier in playback circuit.
68. Variable attenuator to provide proper signal level in playback circuit.
69. Pulse phase demodulator to restore video sweep signal and commentary if pulse position modulation (Option D) was used.
70. Band pass filter for separation of frequency modulated signal to restore video sweep signal.
71. Band pass filter to separate commentary which was recorded clear in mixer (32), and fed to variable attenuator (81) and amplifier (82) for reproduction.

CONFIDENTIAL

72. Frequency discriminator for restoration of video sweep signal.
73. Band pass filter for separation of frequency control signal from oscillator (33) in the case of frequency controlled frequency modulation for video sweep recording. (Option C)
74. Frequency divider (Binary scaler) for frequency stabilization of video sweep signal channel.
75. Band pass filter to restore sine wave from output of binary scaler.
76. Heterodyne mixer for frequency control of stabilized playback circuit.
77. Highly stable control oscillator for stabilization.
78. Band pass filter to eliminate other intermodulation products from heterodyne mixer (76).
79. Variable attenuator to control the level of video sweep signal supplied to the sweep generator.
80. Sweep generator for reproduction of three phase sweep signal from single phase sweep as recorded.
81. Variable attenuator for control of level feeding commentary playback.
82. Power amplifier for playback of commentary.
83. Loudspeaker for playback of commentary.

FIGURE 1
 SPECTRAL ASSIGNMENTS

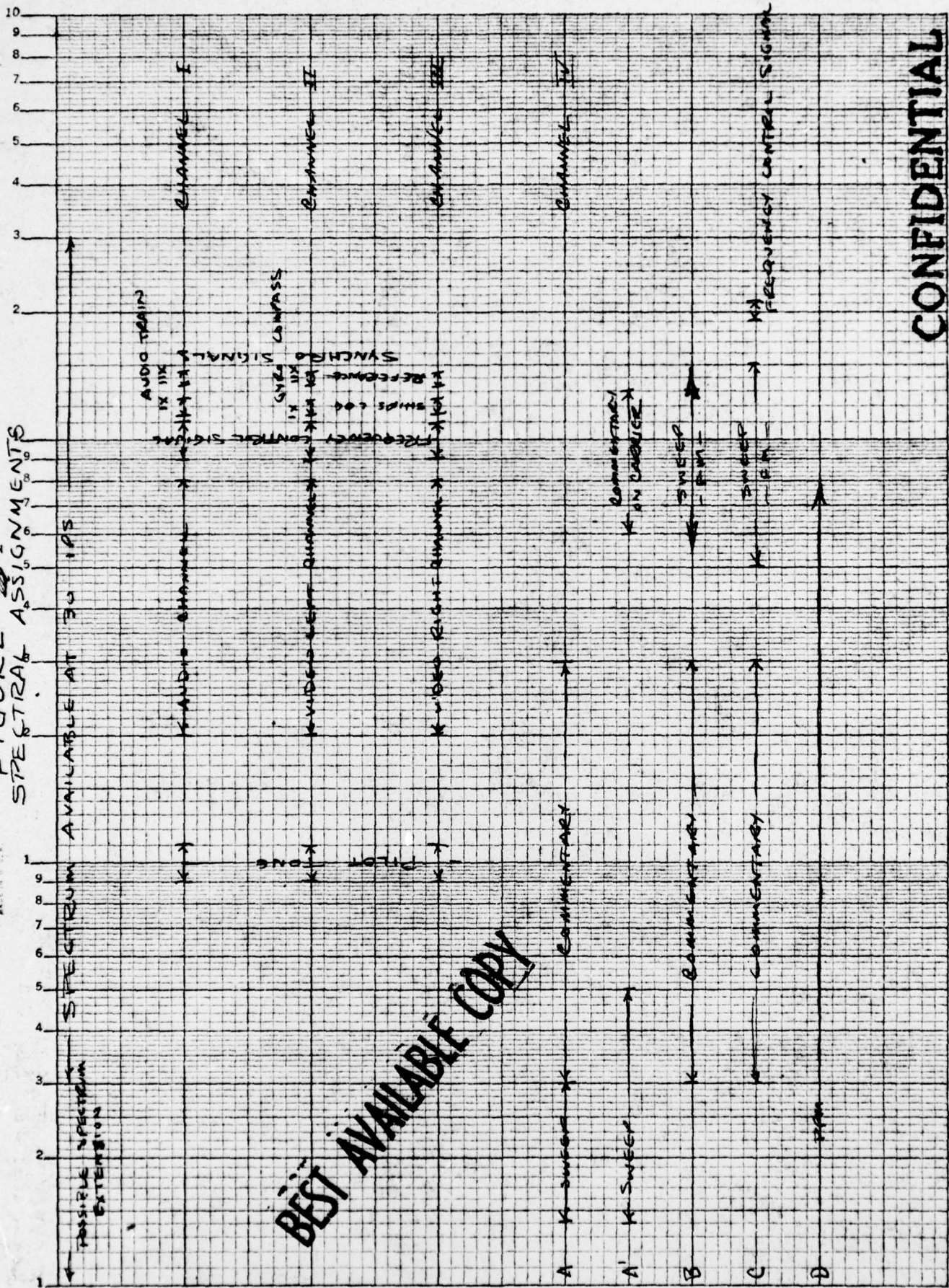

BEST AVAILABLE COPY

CONFIDENTIAL

CO DE 2123 100KC
 7 DEC 54

100C

1000

100

OPTIONS

CONFIDENTIAL

Primary Frequency	(F_s)	14 kc	20 kc	24 kc	25.5 kc
Signal Carrier	(F_r)	4.67 "	5 "	4.8 kc	5.1 "
Beat Frequency	(F_o')	9.33 "	15 "	19.2 "	20.4 "
Oscillator Frequency	(F_o)	9.33 "	5 "	9.6 "	10.2 "
$N (F_o'/F_o)$		1	3	2	2
Control Frequency	(F_r')	9.33 "	10 "	9.6 "	10.2 "
$n (F_r'/F_o)$		1	2	1	1
Amount of Doppler	D				
Fractional increase in tape speed	S				

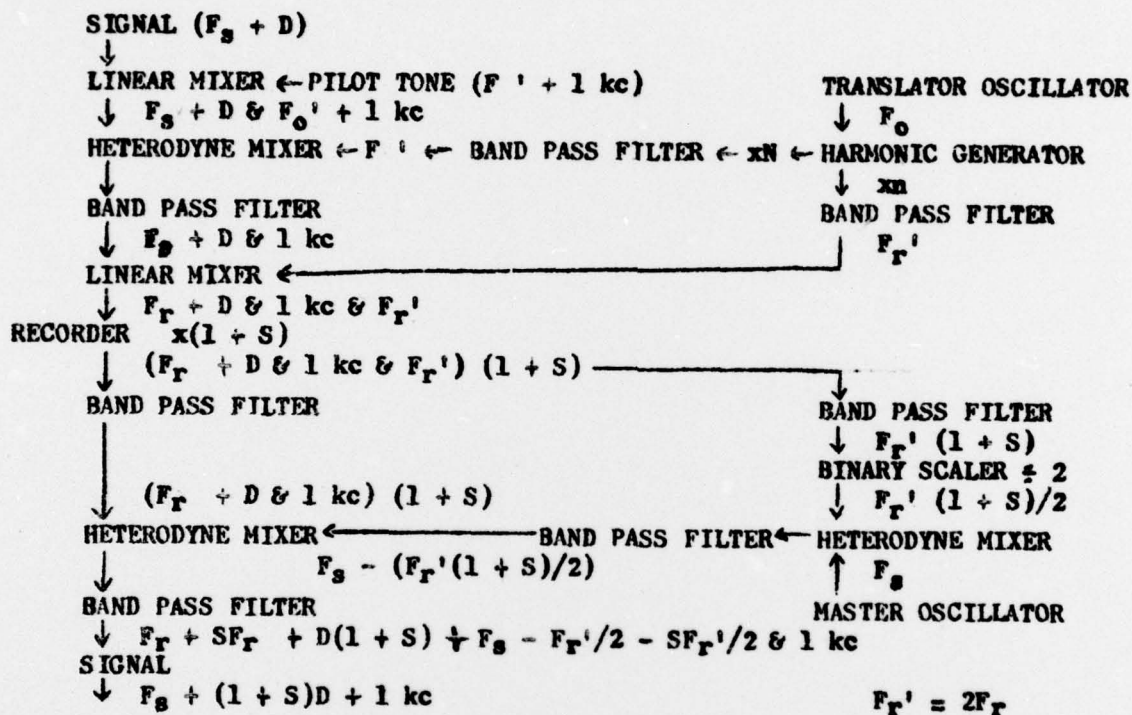

FREQUENCY STABILIZATION

Figure 2

BEST AVAILABLE COPY

Confidential

~~SECRET~~ UNCLASSIFIED
SONAR RAW DATA RECORDING SYSTEM - RECO

BEST AVAILABLE COPY

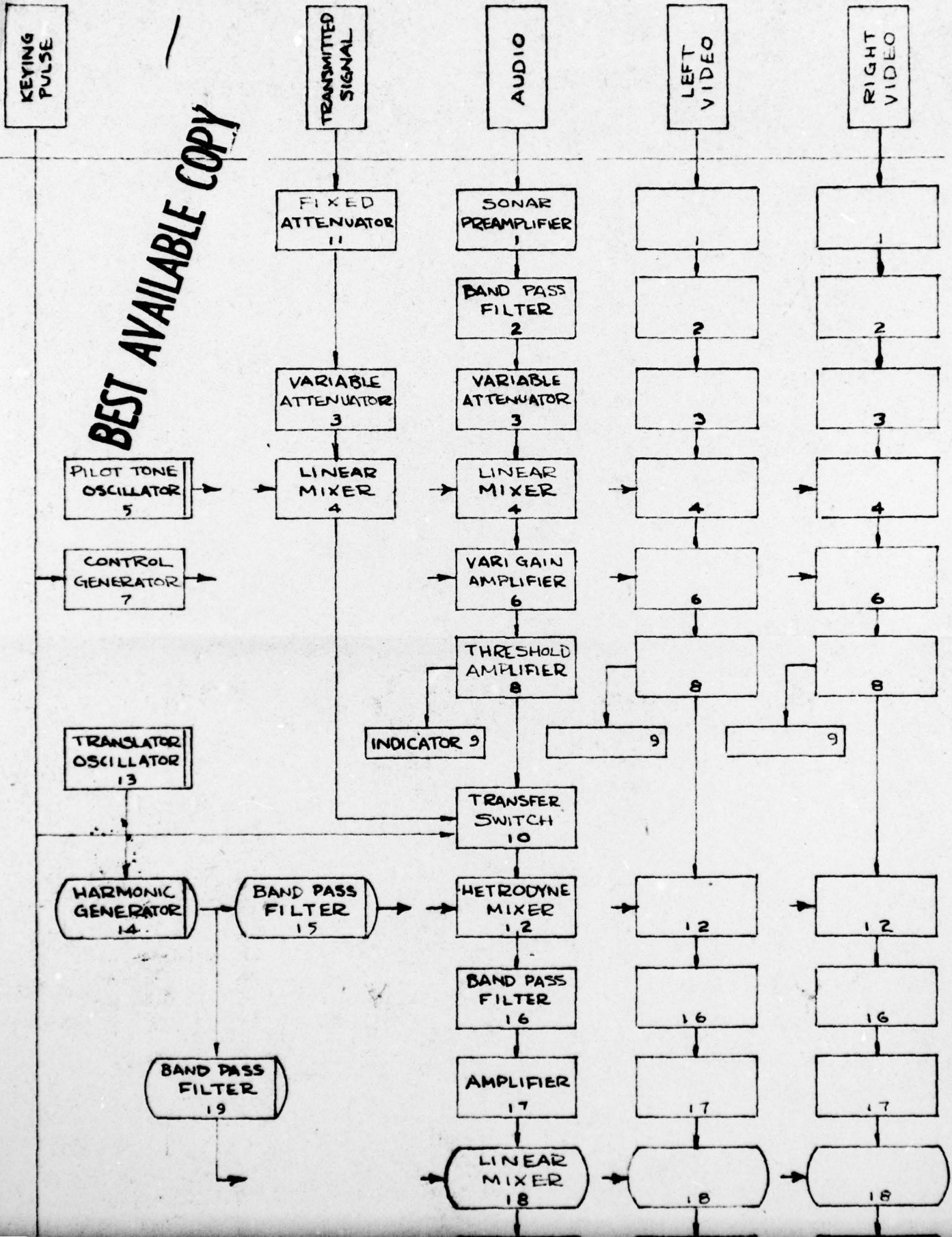

RECORDING BLOCK DIAGRAM

2

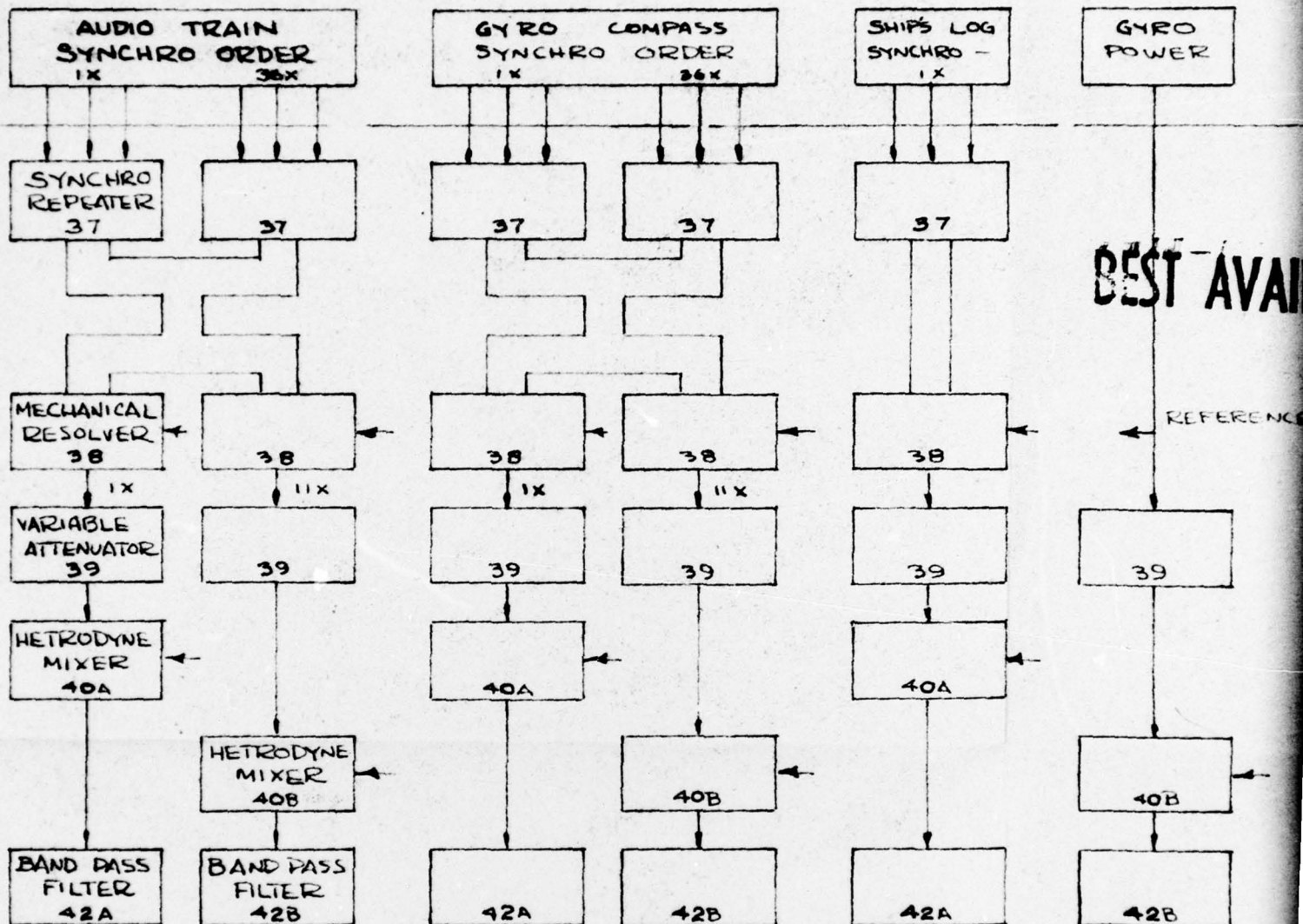

BEST AVAILABLE COPY

1 3

BEST AVAILABLE COPY

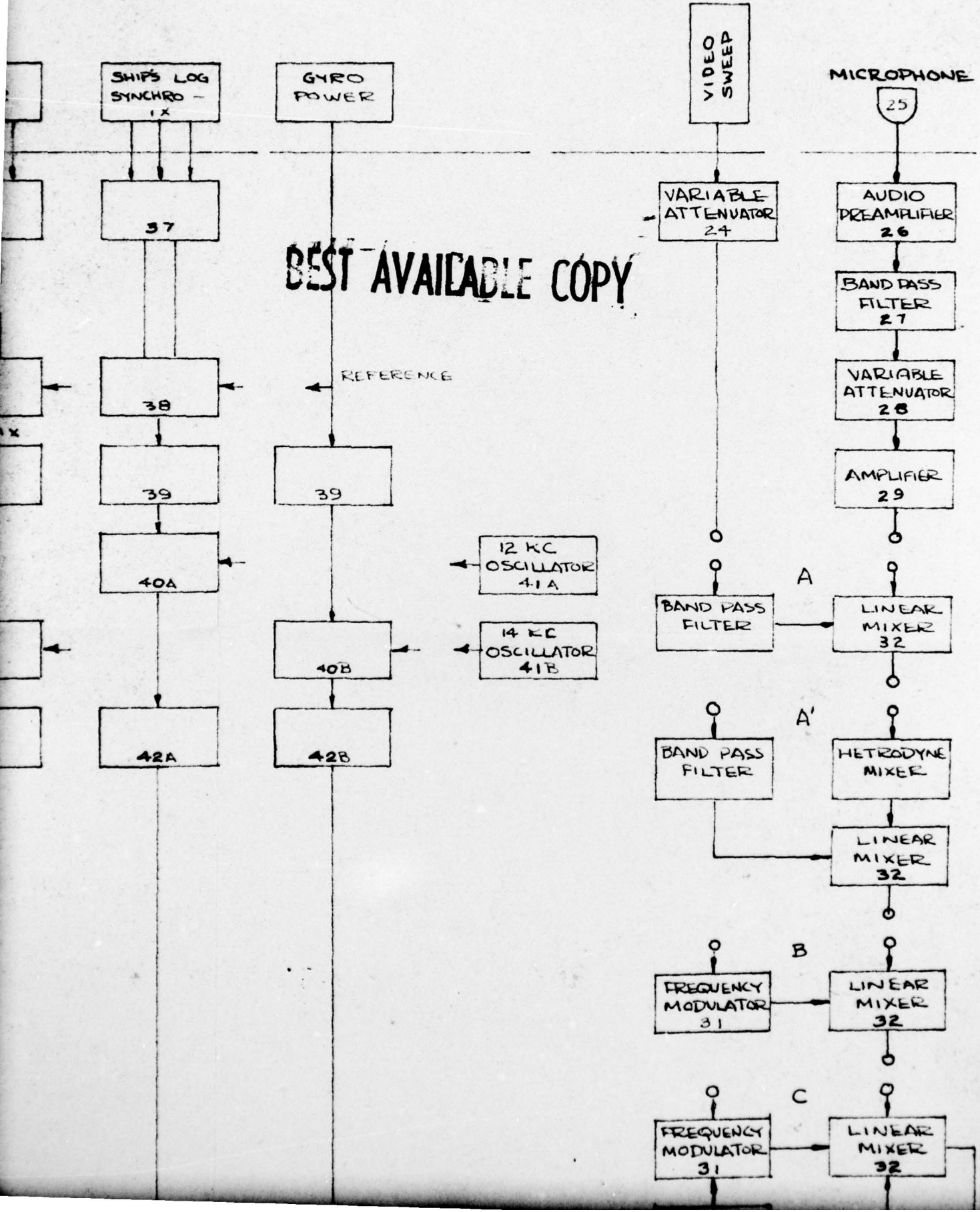

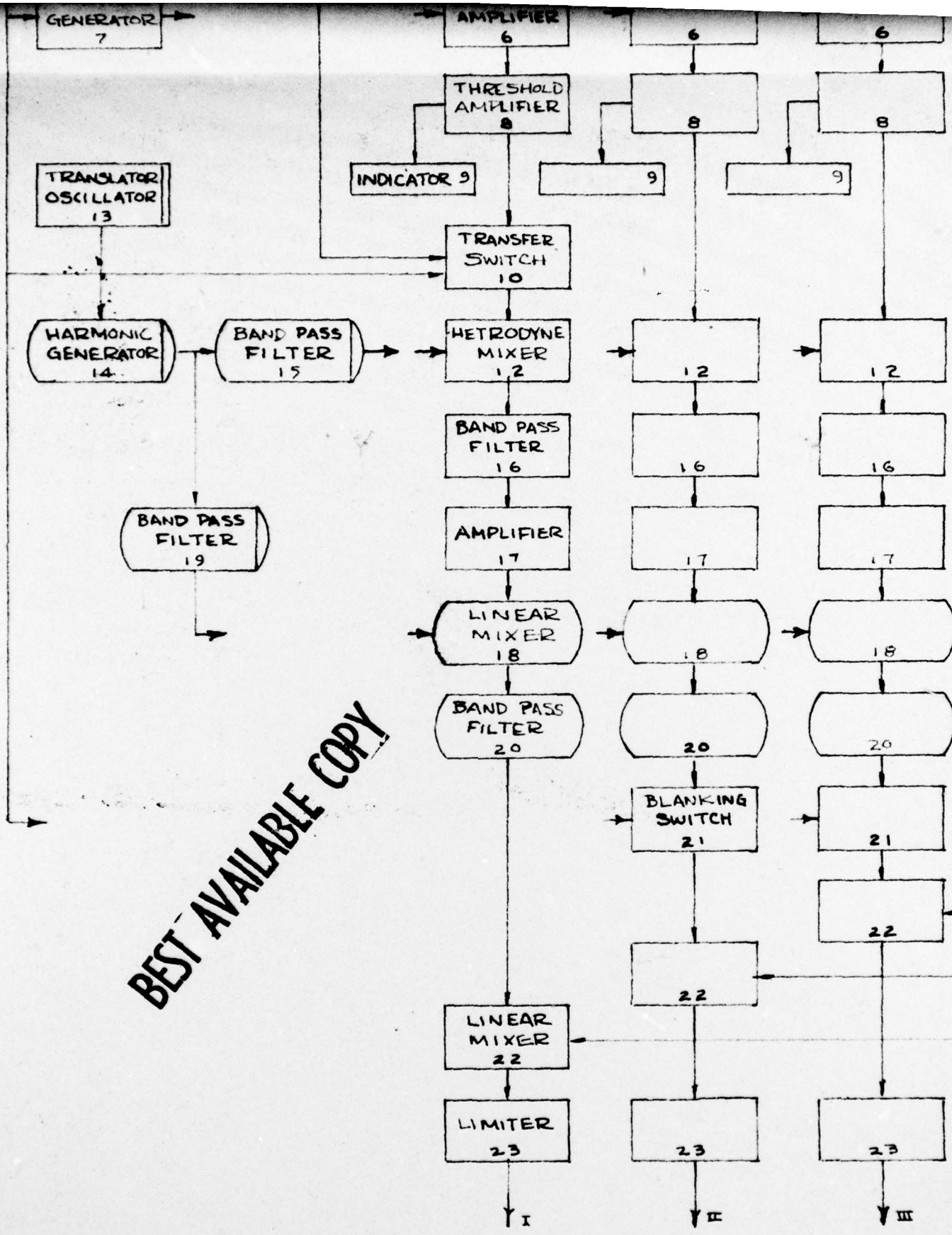

BEST AVAILABLE COPY

TO RECORDER - AMPEX 307-4

H

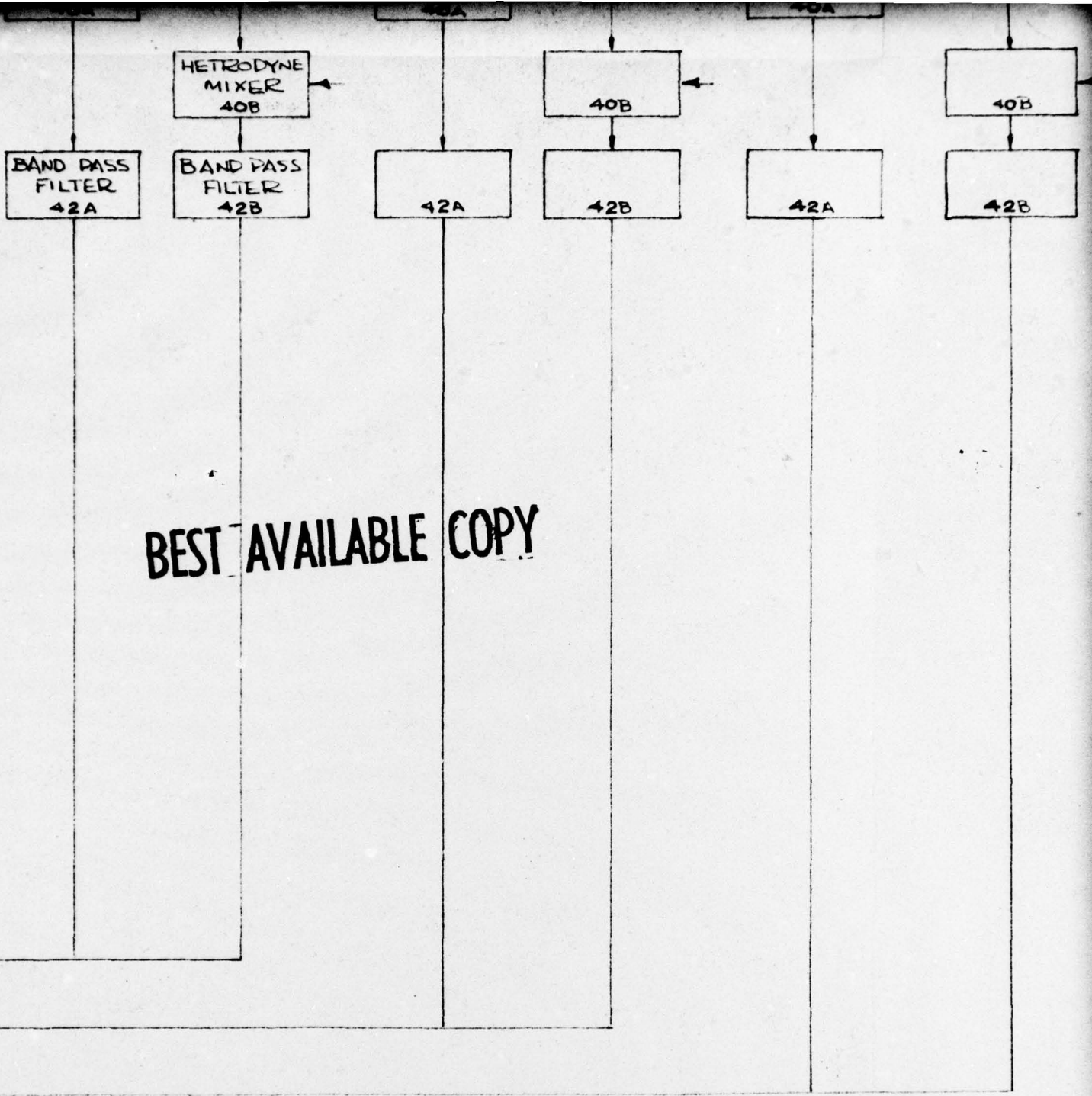



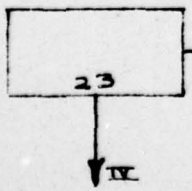

BEST AVAILABLE COPY

BEST A

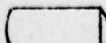

LEGEND

-  ELEMENT
-  PLUG IN
-  OPTIONAL ELEMENT
-  PLUG IN OPTIONAL ELEMENT
-  SIGNAL
-  MECHANIC

007-4

1
D

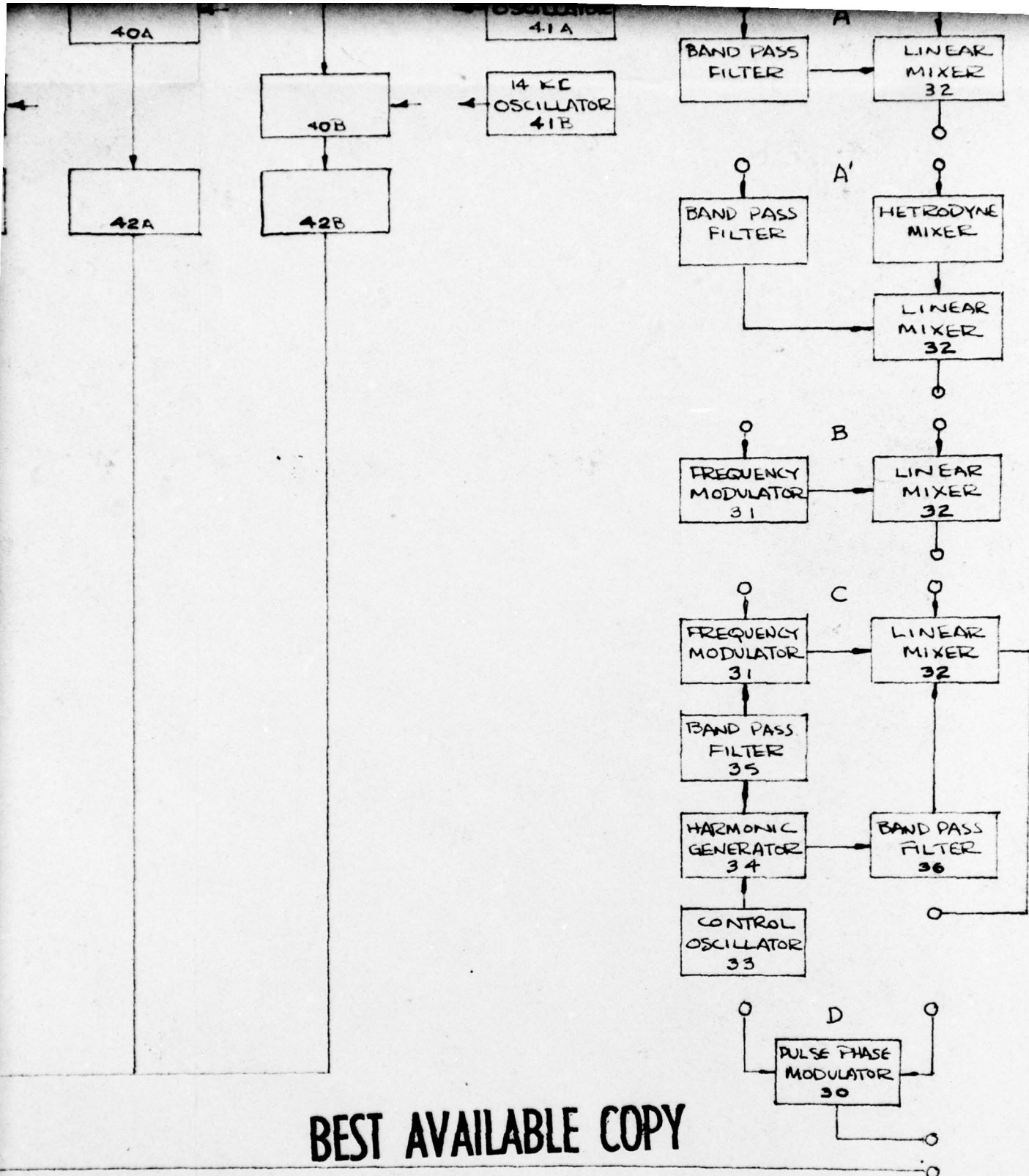

BEST AVAILABLE COPY

LEGEND

- ELEMENT → SIGNAL COUPLING
- PLUG IN [Wavy Line] MECHANICAL COUPLING
- OPTIONAL ELEMENT
- PLUG IN OPTIONAL ELEMENT

~~UNCLASSIFIED~~

Figure 3

CODE 2123
23 NOV 54

SONAR RAW DATA RECORD

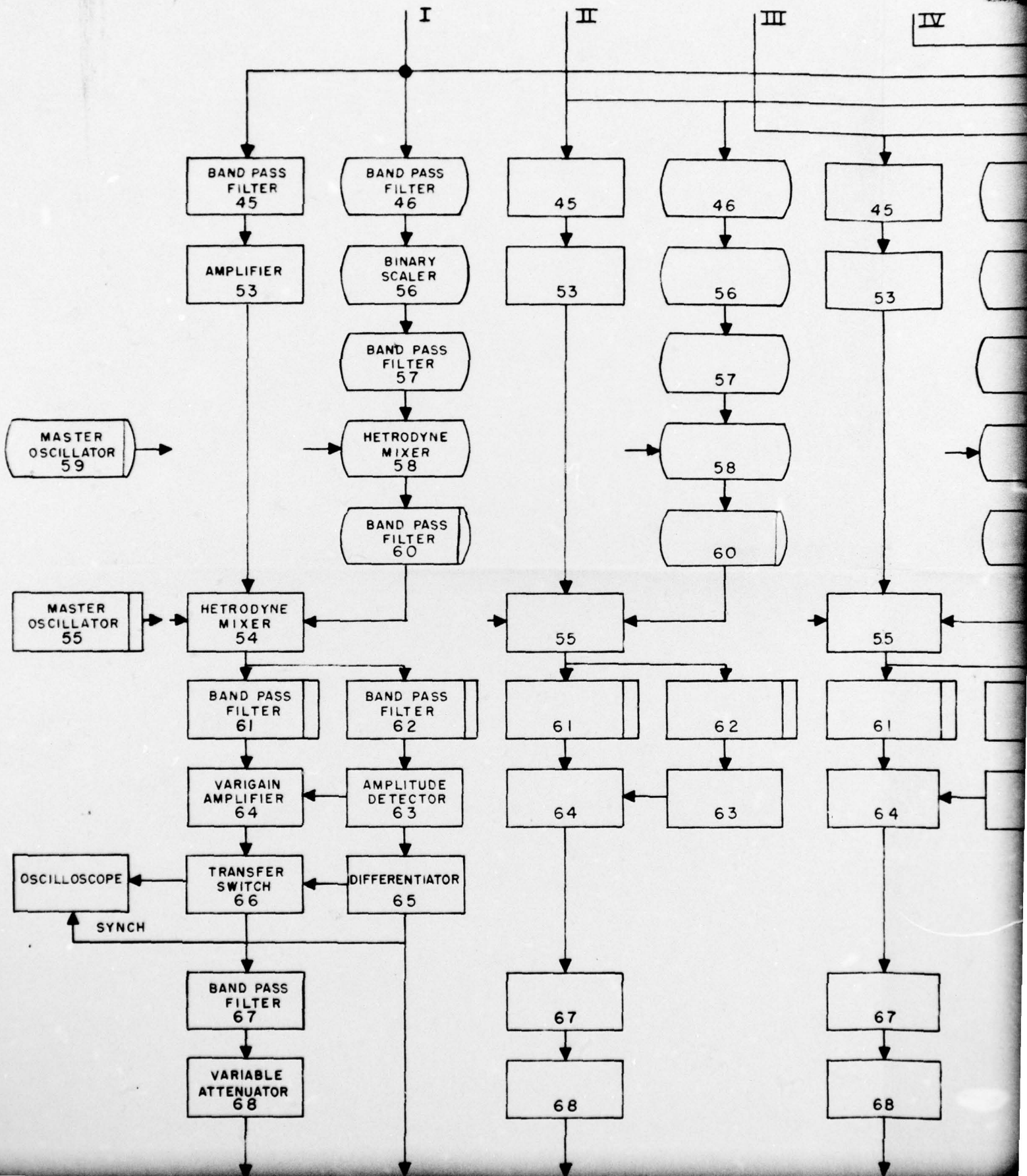

RECORDING SYSTEM - PLAYBACK BLOCK DIAGRAM

2
UNCLASSIFIED

IV

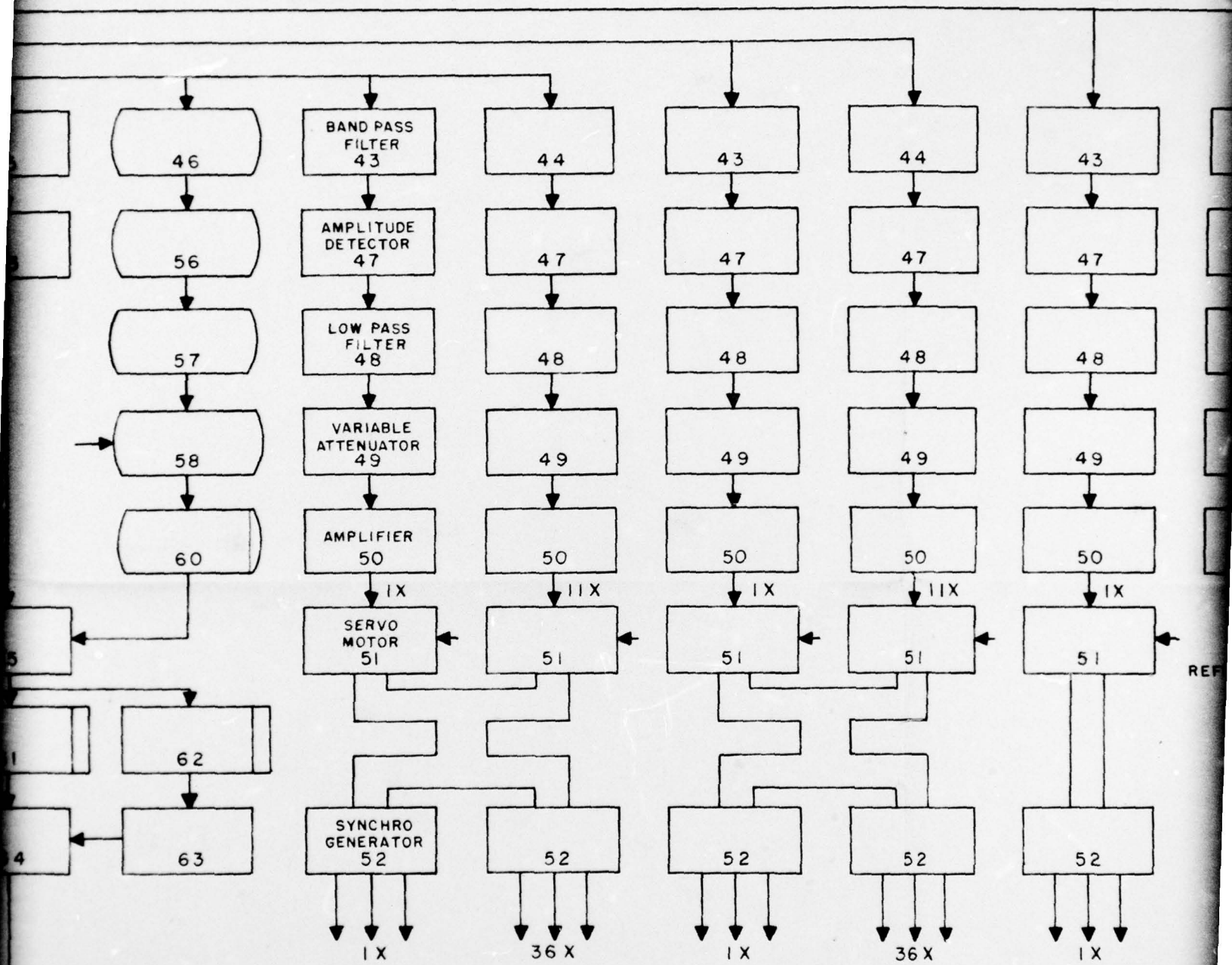

**AUDIO TRAIN
SYNCHRO ORDER**

**GYRO COMPASS
SYNCHRO ORDER**

**SHIPS LOG
SYNCHRO ORDER**

57
58

BLOCK DIAGRAM

3

CLASSIFIED

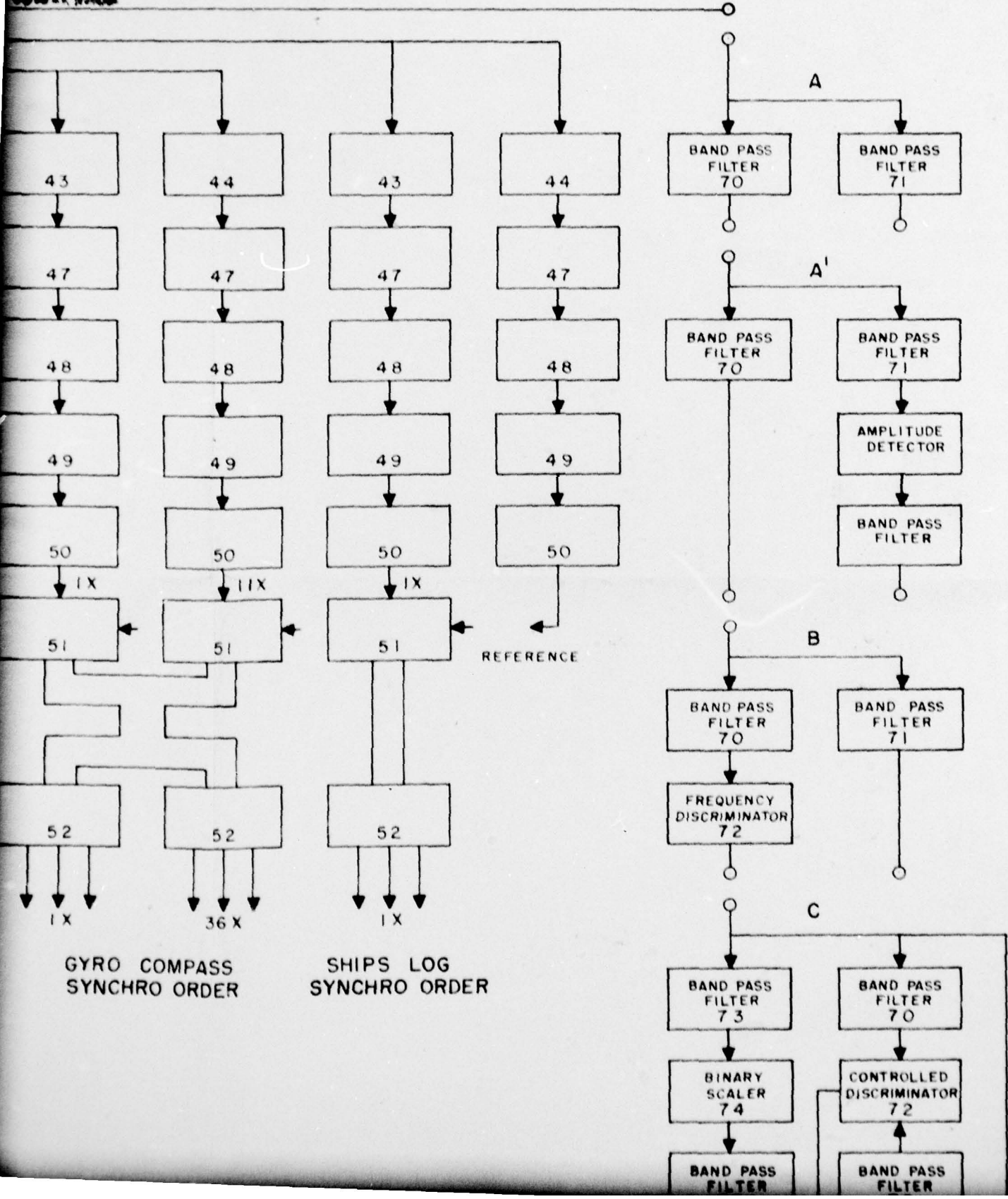

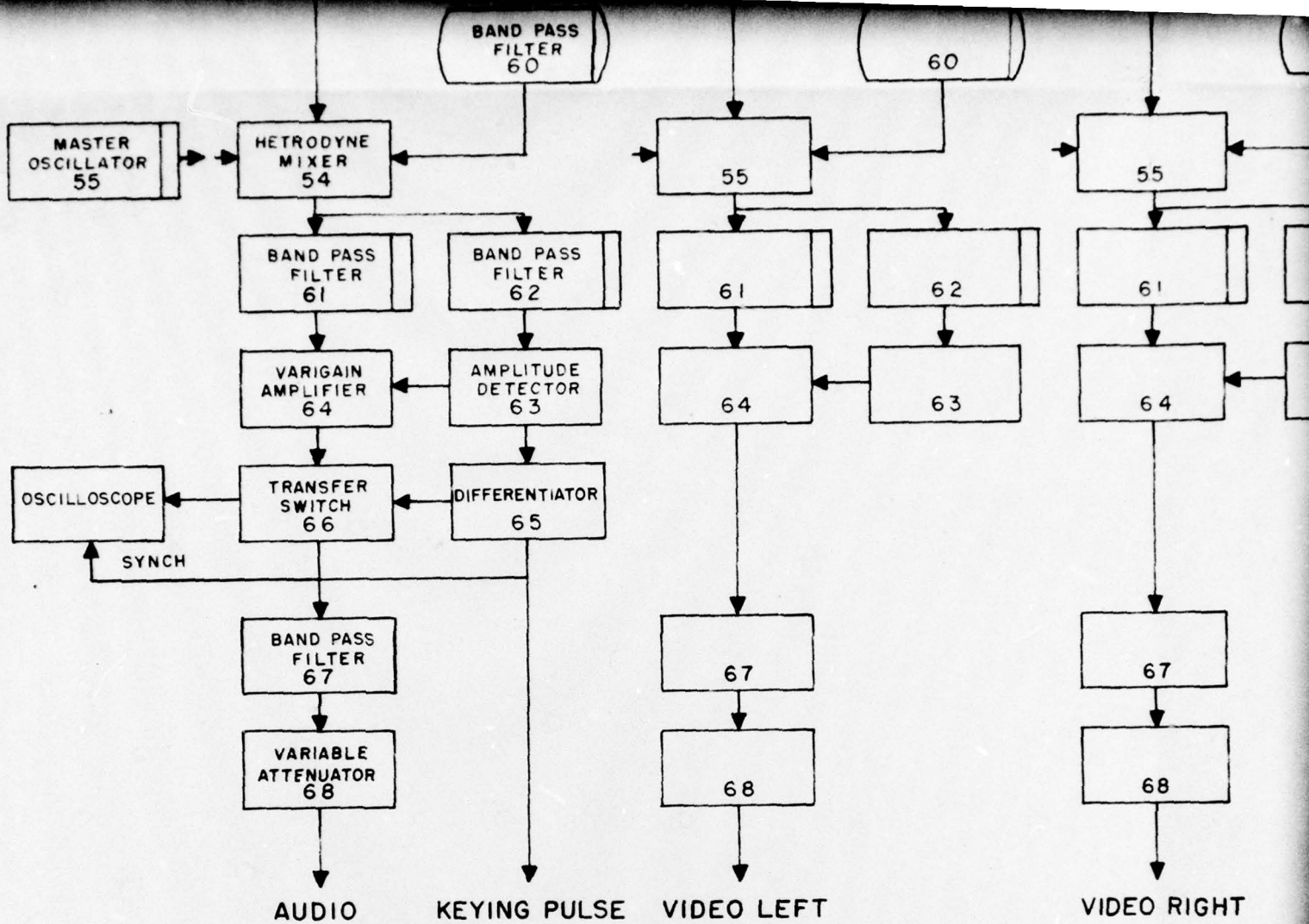

4

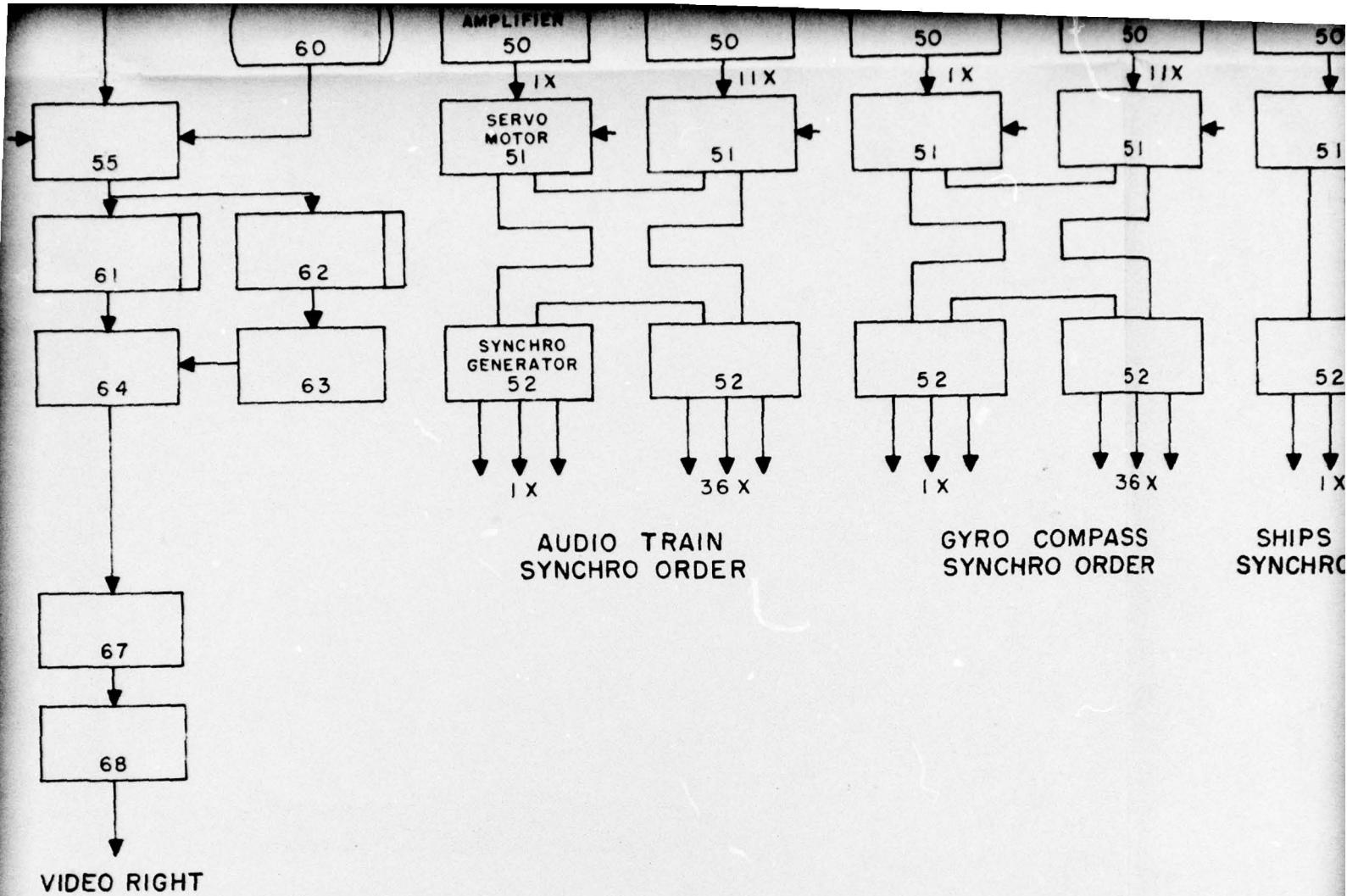

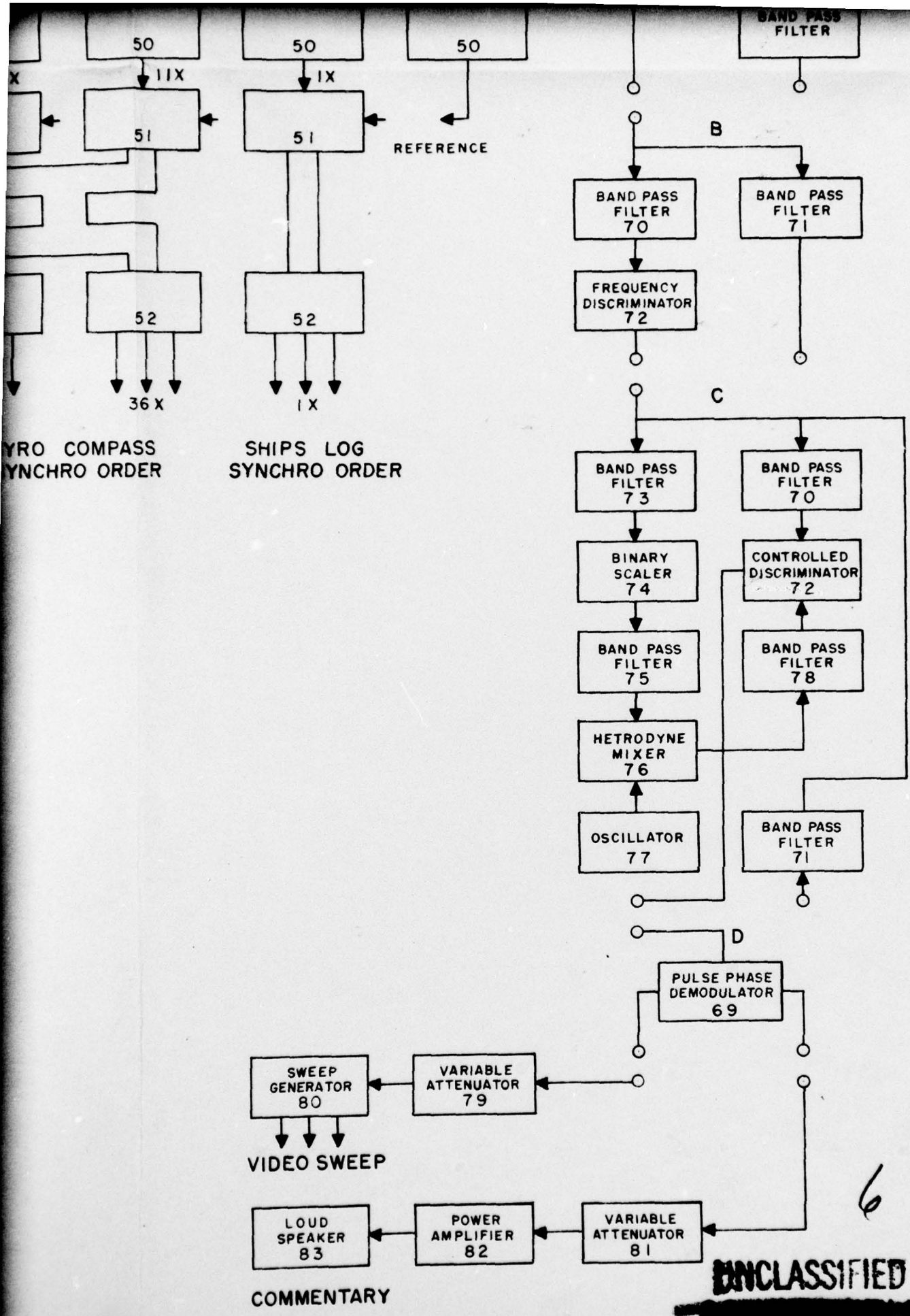

6

UNCLASSIFIED

Figure 4