

AD-A051 926

HONEYWELL INC ST PETERSBURG FL AVIONICS DIV F/G 17/2
ATEC DIGITAL ADAPTATION STUDY, DEVELOPMENT AND FIELD EVALUATION--ETC(U)
JAN 78 T J CAMPBELL, W F ACKER, C L CHRISTNER F30602-75-C-0282
1077-14813-VOL-2 RADC-TR-77-431-VOL-2 NL

UNCLASSIFIED

1 of 4
AD
A051926



AD A 051926

2
NW

RADC-TR-77-431, Volume II (of three)
Final Technical Report
January 1978



ATEC DIGITAL ADAPTATION STUDY, Development and Field
Evaluation - Digital Automated Technical Control

Mr. T.J. Campbell
Dr. W.F. Acker
Mr. C.L. Christner

Mr. D.T. Doyle
Mr. W.M. Goldstein
Mr. R.L. Tufaner

Honeywell Inc.

AD No. _____
DDC FILE COPY

DDC
RECEIVED
MAR 30 1978
F

Approved for public release; distribution unlimited.

BEST AVAILABLE COPY

ROME AIR DEVELOPMENT CENTER
Air Force Systems Command
Griffiss Air Force Base, New York 13441

Because of the size of this report, it has been divided into three volumes. Volume I contains Sections 1 through 5. Volume II contains Section 6. Volume III contains Section 7 and Appendices A and B.

The quality of copy of test data and/or results is the best available. The reproduction was the original copy which cannot be duplicated or better copy produced. The test data is not of the highest printing quality but because of economical consideration, it was determined in the best interest of the government that it be used in this publication.

This report has been reviewed by the RADC Information Office (OI) and is releasable to the National Technical Information Service (NTIS). At NTIS it will be releasable to the general public, including foreign nations.

RADC-TR-77-431, Volume II (of three) has been reviewed and is approved for publication.

APPROVED:

Arnold E. Argenzia
ARNOLD E. ARGENZIA
Project Engineer

APPROVED:

Fred I. Diamond
FRED I. DIAMOND
Technical Director
Communications and Control Division

FOR THE COMMANDER:

John P. Huss
JOHN P. HUSS
Acting Chief, Plans Office

If your address has changed or if you wish to be removed from the RADC mailing list, or if the addressee is no longer employed by your organization, please notify RADC (DCLD) Griffiss AFB NY 13441. This will assist us in maintaining a current mailing list.

Do not return this copy. Retain or destroy.

UNCLASSIFIED

SECURITY CLASSIFICATION OF THIS PAGE (When Data Entered)

REPORT DOCUMENTATION PAGE		READ INSTRUCTIONS BEFORE COMPLETING FORM
1. REPORT NUMBER 18 17 RADCTR-77-431 -Vol-II (of three)	2. GOVT ACCESSION NO.	3. RECIPIENT'S CATALOG NUMBER
4. TITLE (and Subtitle) 6 ATEC DIGITAL ADAPTATION STUDY, Development and Field Evaluation - Digital Automated Technical Control,	5. TYPE OF REPORT & PERIOD COVERED Final Technical Report, Mar 1977 - Aug 1977	6. PERFORMING ORG. REPORT NUMBER 34 1077-14813-Vol-2
7. AUTHOR(s) 10 Mr. T.J. Campbell , Mr. D.T. Doyle Mr. W.F. Acker , Mr. W.M. Goldstein Mr. C.L. Christner , Mr. R.L. Tufaner	8. CONTRACT OR GRANT NUMBER(s) 15 F30602-75-C-0282	
9. PERFORMING ORGANIZATION NAME AND ADDRESS Honeywell Inc./Avionics Division 13350 U.S. Highway 19 St. Petersburg FL 33733	10. PROGRAM ELEMENT, PROJECT, TASK AREA & WORK UNIT NUMBERS 33126F 21550101	
11. CONTROLLING OFFICE NAME AND ADDRESS Rome Air Development Center (DCLD) Griffiss AFB NY 13441	12. REPORT DATE 71 Jan 1978	13. NUMBER OF PAGES 318
14. MONITORING AGENCY NAME & ADDRESS (if different from Controlling Office) Same	15. SECURITY CLASS. (of this report) UNCLASSIFIED 15a. DECLASSIFICATION/DOWNGRADING SCHEDULE N/A	
16. DISTRIBUTION STATEMENT (of this Report) Approved for public release; distribution unlimited.		
17. DISTRIBUTION STATEMENT (of the abstract entered in Block 20, if different from Report) Same		
18. SUPPLEMENTARY NOTES RADC Project Engineer: Arnold E. Argenzia (DCLD) (See reverse)		
19. KEY WORDS (Continue on reverse side if necessary and identify by block number) Performance Assessment, Fault Isolation, and Trend Analysis (PA/FI/TA) in Digital Transmission Systems ATEC (Automatic Technical Control) Applicability for PA/FI/TA in the FKV Digital Transmission System Sudden Service Failure Sensing System (SSFSS)		
20. ABSTRACT (Continue on reverse side if necessary and identify by block number) Subsequent to the completion of the feasibility phase of the ATEC Digital Adaptation Study, existing ATEC hardware and software was adapted or developed to provide Performance Assessment (PA), Fault Isolation (FI) and Trend Analysis for the FKV type digital transmission systems. The resulting DATEC system was then field tested using the facilities of the digital transmission test bed located at Ft. Huachuca, Arizona. The purpose of the field evaluation was to confirm the basic concepts, exercise and test the developed hardware		

DDC
MAR 30 1978
FBI

393 215

403 190

EB

UNCLASSIFIED

SECURITY CLASSIFICATION OF THIS PAGE(When Data Entered)

and software, and verify DATEC's capabilities to accomplish PA/FI/TA in the operational environment of an operating digital transmission system. These DATEC capabilities are directed towards the centralized nodal monitoring of numerous digital transmissions links.

The DATEC field evaluation confirmed both the practicality and advantages inherent in automated digital system monitoring, insofar as enabling the centrally located controller to performance assess, trend analyze and fault isolate the digital transmission system for numerous failure occurrences and patterns and system parameter degradation. DATEC enables technicians to monitor in-service system parameters thereby enhancing system performance and allowing more efficient utilization of maintenance resources.

Block 18. (Continued)

Because of the size of this report, it has been divided into 3 volumes:

Volume I contains Sections 1 through 5.

Volume II contains Section 6.

Volume III contains Sections 7 and Appendices A and B.

ACCESSION for	_____
NTIS	<input checked="" type="checkbox"/>
DDC	<input type="checkbox"/>
UNANIMATED	<input type="checkbox"/>
JUSTIFICATION	<input type="checkbox"/>
BY	DISTRIBUTION/INITIALS
Dist	_____
A	_____

UNCLASSIFIED

SECURITY CLASSIFICATION OF THIS PAGE(When Data Entered)

Section 6

FIELD TEST RESULTS RELATIVE TO STATEMENT OF WORK REQUIREMENTS

GENERAL

This section is essentially reproduced from Section III of the test report for the Field Test and Evaluation phase of the ATEC Digital Adaptation program. The data taken from the test scenarios has been included with this section to provide a convenient reference.

SUMMARY

The primary objective of the field tests, as stated in the Statement of Work (S.O.W.) for the ATEC Digital Adaptation Study, was *to give the DATEC system a detailed shakedown via operational testing so that its feasibility and its potential use in an operational digital system, as typified by the FKV system, could be determined*. In a more explicit manner, the S.O.W. breaks down the primary objective into 23 separate evaluation items. The purpose of Paragraph 6.1 of this section of the test report is to list each of these items (tasks) individually along with substantiating data or other material relating to the topic, not only to more clearly demonstrate compliance with the S.O.W., but also to present in the most straightforward manner the advantages (and disadvantages) of the DATEC system with respect to program requirements.

Preceding the list of 23 evaluation items and providing a quick reference summary of S.O.W. compliance, is a matrix relating each evaluation item to the validation test or test scenario in which it was addressed. This matrix is presented as Table 6-1.

Also included in this section are comments specifically addressing a number of software related tasks delineated in Paragraph 4.1.12.10.4 of the S.O.W. These comments may be found in Paragraph 6.2.

Finally, Paragraph 6.3 of this section is concerned with several additional items suggested by RADC for consideration.

BACKGROUND

The operational Field tests which were conducted were divided into two distinct categories. The first phase dealt with a quantitative check of the DATEC system; that is, in the operational communication system environment, known perturbations were

introduced to elicit measurable and expected results. These tests validated the basic requirements imposed on DATEC as a monitoring system and verified DATEC/communication system interface compatibility. The second phase of testing dealt with the more subjective aspects of evaluating the DATEC system relative to its utility and effectiveness as a monitoring system. In order to more accurately assess these aspects, among which was the man-machine relationship, the tests were conducted in a series of scenarios with site operational personnel (Tech Controllers) operating as the Nodal Controllers. Again, perturbations to the communication system were introduced, with the emphasis in this case on realism, and for the purpose of exploiting the capabilities of the DATEC system relative to Performance Assessment, Fault Isolation and Trend Analysis.

References are made in this section to field test System Simulation Scenario test data to illustrate certain aspects of DATEC evaluation. This data is included throughout this section as explained below. These scenarios involved a simulated anomaly or multiple anomalies to the communication system. Tech controllers from the service, working in pairs, were at the nodal control position at Ft. Huachuca. The tech controllers had received several hours of briefing on DATEC equipment, its relationship to the communication system, use of the different displays and the method of calling up displays via the keyboard.

One or more perturbations were introduced to the communication system by Honeywell personnel during each scenario. A predetermined procedure was used. The time of each perturbation introduction was noted on the procedure sheets. The tech controllers - one of which was in command the other in charge of making notations and keeping records - logged their entries on a DATEC System Evaluation Worksheet. To help document their activities, they made printouts of various displays which they considered pertinent during conduction of the scenarios. The excerpts, then, consist of matter taken from these procedures, worksheets, and printouts which are considered appropos for illustration purposes.

6.1 VALIDATION/EVALUATION CRITERIA LIST

This section presents detailed discussions of 23 specific items delineated in the S.O.W. for consideration during the field test phase of the ATEC Digital Adaptation Study. Although a number of the items are closely related, each is treated separately in an effort to demonstrate complete compliance with the S.O.W.

As a summary guide, the matrix shown in Table 6-1, following, gives a cross reference between the S.O.W. requirements paragraph number (4.1.12.7.1 through 4.1.12.7.23); the paragraphs of this section addressing the particular S.O.W. requirement; the Validation Test/Simulation Scenario addressing the S.O.W. requirement; and the field test report paragraph number in Section II of that report where the Validation Test/Simulation Scenario data may be found.

TABLE 6-1. DATEC FIELD TEST AND EVALUATION CROSS REFERENCE MATRIX

Para Ref		Evaluation Tasks Specified by the Statement of Work	Validation Tests		Simulation Scenarios																										
Statement of Work	Test Report		A	B	C	D	E	F	G	H	I	J	K	L	M	N	O	P	Q	R	S	T	U	V	W	X	Y	Z			
			2.3.1	2.3.2	2.3.3	2.3.4	2.3.5	2.3.6	2.3.7	2.3.8	2.3.9	2.4.1	2.4.2	2.4.3	2.4.4	2.4.5	2.4.6	2.4.7	2.4.8	2.4.9	2.4.10	2.4.11	2.4.12	2.4.13	2.4.14	2.4.15	2.4.16	2.4.17	2.4.18		
		<p>Validation Tests: SSFSS, Alarms, and Two-State Parameters; RSL Margin and Availability; Maintenance Voltages; TIMB1 Framing Error Rates and Reframe; 4000 and Control Rate; Error Rate, Availability and Control Rate; Baseband Eye Monitor Parameters; Correlative Parameters; VF Channel Measurements; Operation with Degraded Conditions; Link RF Fading (Propagation); Single Receiver Fade; 3. Simultaneous Deep Fade; Receiver Noise Figure Degradation - A vs B; Transmitter Output Power Problem; Antenna Misalignment; High Level RX Failure - Power Supply; 1. TX Failure; 2. Transist. Antenna Only at Sibyl; TI-4000 Multiple Maintenance Error - SBL; Low Level RX Failure - Power Supply; High Level RX Failure - Power Supply; RFI at Baseband Level; RFI Above Reference; RFI at Baseband Level; Multiple Link Equipment Failures; TI-4000 Framing Error Equipment Failure; TIMB1 Framing Error Equipment Failure; User Equipment Degradation Without Channel Simulator; High Channel Simulator; Low Level RX Failure, Power Supply, RMA; TI-4000 Framing Error Equipment Failure, RMA; TIMB1 Framing Error Equipment Failure, RMA; High Level RX Failure, Power Supply, RMA; High Level RX Failure, Power Supply, SBL; Operation Under Degraded Conditions; Higher RX Failure, TIMB1 Channel Card; Unrelated Multiple Failures, 1; Unrelated Multiple Failures, 2; Special RSL Long Term Test.</p>																													
		Field Test Report Paragraph Containing Detailed Test Data																													
4.1.12.7.1	6.1.1	The Parameters/Alarms Monitored for CPMS.	X	X	X	X	X	X	X	X	X	X	X	X	X	X	X	X	X	X	X	X	X	X	X	X	X	X	X	X	
4.1.12.7.2	6.1.2	The DATEC software adaptation requirements specified in Paragraphs 1.3 through 1.3.1.4 of Annex 2 of the S.O.W.	X	X	X	X	X	X	X	X	X	X	X	X	X	X	X	X	X	X	X	X	X	X	X	X	X	X	X	X	
4.1.12.7.3	6.1.3	The hardware adaptation requirements specified in Paragraphs 1.2 through 1.2.2.9 of Annex 2 of the S.O.W.		X	X	X	X	X	X	X	X	X	X	X	X	X	X	X	X	X	X	X	X	X	X	X	X	X	X	X	
4.1.12.7.4	6.1.4	The DATEC capability to accomplish sudden service failure sensing, omnistratometric monitoring, and nodal control monitoring.	X	X	X	X	X	X	X	X	X	X	X	X	X	X	X	X	X	X	X	X	X	X	X	X	X	X	X	X	
4.1.12.7.5	6.1.5	The DATEC performance in both the active scan and the special request modes of operation.	X	X	X	X	X	X	X	X	X	X	X	X	X	X	X	X	X	X	X	X	X	X	X	X	X	X	X	X	
4.1.12.7.6	6.1.6	The DATEC capability to accomplish the proposed CPMS functions, to provide this information in a timely manner, to achieve and maintain the performance objectives of the FKV type system.	X	X	X	X	X	X	X	X	X	X	X	X	X	X	X	X	X	X	X	X	X	X	X	X	X	X	X	X	
4.1.12.7.7	6.1.7	The DATEC capability to facilitate CPMS procedures.	X	X	X	X	X	X	X	X	X	X	X	X	X	X	X	X	X	X	X	X	X	X	X	X	X	X	X	X	
4.1.12.7.8	6.1.8	The adequacy, effectiveness, and feasibility of the DATEC system concept and its components in monitoring, testing, analyzing, presenting, and reporting CPMS information.	X	X	X	X	X	X	X	X	X	X	X	X	X	X	X	X	X	X	X	X	X	X	X	X	X	X	X	X	
4.1.12.7.9	6.1.9	The accuracy, reliability, utility, and completeness of the data queries, analyses, summaries, and output displays.	X	X	X	X	X	X	X	X	X	X	X	X	X	X	X	X	X	X	X	X	X	X	X	X	X	X	X	X	
4.1.12.7.10	6.1.10	The accuracy, reliability, and utility of the DATEC measurements relative to circuits of different qualities, i.e., determine the operational scope of the DATEC measurements.							X													X									
4.1.12.7.11	6.1.11	The accuracy, reliability, and utility of the performance assessment/trend analysis capabilities to resolve degradations.	X	X								X	X	X	X	X	X	X	X	X	X	X	X	X	X	X	X	X	X	X	
4.1.12.7.12	6.1.12	The fault location times as affected by DATEC.										X																			
4.1.12.7.13	6.1.13	The output data relative to its utility in optimizing preventative maintenance schedules and the maintenance effort of the FKV type equipment.	X	X						X			X	X	X	X	X	X	X	X	X	X	X	X	X	X	X	X	X	X	
4.1.12.7.14	6.1.14	The ability of DATEC to provide sufficient information to determine the proper thresholds for alarm/parameter indicators.	X	X	X	X	X	X	X	X	X										X										
4.1.12.7.15	6.1.15	The recommended sample rates for the most effective use of DATEC.										X																			
4.1.12.7.16	6.1.16	The communications system operations during degraded/normal operating conditions of the DATEC system.								X																					
4.1.12.7.17	6.1.17	The DATEC system operations during degraded conditions of both the communications system and the DATEC system.								X																					
4.1.12.7.18	6.1.18	The capability of DATEC to recover from a power loss.																													
4.1.12.7.19	6.1.19	The ability of nodal site to obtain information on parameters/alarms monitored at the remote site.	X	X	X	X	X	X	X	X					X	X	X	X	X	X	X	X	X	X	X	X	X	X	X	X	
4.1.12.7.20	6.1.20	The effects of DATEC caused by degradation or total outage of the transmission link connecting the DATEC with the remote site DATEC equipments.	X								X																				
4.1.12.7.21	6.1.21	The man-machine interface and if the interface can be easily accomplished in the operational environment, and if it is presented in a format that is useful to operational personnel.									X	X	X	X	X	X	X	X	X	X	X	X	X	X	X	X	X	X	X	X	
4.1.12.7.22	6.1.22	The ability to use DATEC without the support of on-site computer software personnel.									X	X	X	X	X	X	X	X	X	X	X	X	X	X	X	X	X	X	X	X	
4.1.12.7.23	6.1.23	The ease with which data base changes most frequently required during operation can be accomplished.																													

6.1.1 The Parameters/Alarms Monitored for CPMAS

Following is a list of the parameters and alarms monitored by DATEC along with an associated list of CRT display pages where these parameters/alarms are displayed.

TABLE 6-2. PARAMETERS/ALARMS MONITORED FOR CPMAS

<u>Parameter/Alarm</u>	<u>CRT Display Page</u>
<u>Radio:</u>	
RSL Margin	Link Status, Page 1; Link Performance Assessment (P.A.), Page 1
RSL Availability	Link P.A., Page 1
Eye Margin	Link Status, Page 1; Link P.A., Page 1
Eye Availability	Link P.A., Page 1
Eye Amplitude (dBm)	Link Status, Page 1
Eye Hits	Link Status, Page 1; Link P.A., Page 1
Eye Voltage (Dispersion Vdc)	Link P.A., Page 2
Derived BER	Link Status, Page 1
Receiver Squelch	Link Status, Page 1; Link P.A., Page 2
Maintenance Voltages (+24 Vdc, -20 Vdc; RX A only)	Maintenance Voltages
Radio RX (Major Alarm)	System Overview*
TX Problem	System Overview; Link Status, Page 1*
RX Problem	System Overview; Link Status, Page 1*
TX In-Service	Link Status, Page 1*

* Also displayed on Alarm Scanner and Alarm Display.

TABLE 6-2. PARAMETERS/ALARMS MONITORED FOR CPMAS (Continued)

<u>Parameter/Alarm</u>	<u>CRT Display Page</u>
<u>Radio: (Continued)</u>	
RX In-Service	Link Status, Page 1*
Maintenance	System Overview; Link Status, Page 1*
<u>T1-4000:</u>	
Frame Error Rate (FER)	Link Status, Page 1; Link P.A., Page 3
FER Availability	Link P.A., Page 3
Control Reframe	Link Status, Page 1; Link P.A., Page 3
Maintenance Voltages (+5 Vdc, -6 Vdc; A MUX only)	Maintenance Voltages
Switch Major (Alarm)	System Overview; Link Status, Page 1*
Switch Minor (Alarm)	System Overview; Link Status, Page 1*
Major (Alarm)	System Overview; Link Status, Page 1*
TX In-Service	Link Status, Page 1*
RX In-Service	Link Status, Page 1*
Maintenance	System Overview; Link Status, Page 1*
<u>CY-104:</u>	
Channel (VF Level and Signal/Noise Ratio)	Link Status, Page 2
Service (Alarm)	Link Status, Page 2*
Remote (Alarm)	Link Status, Page 2*
Maintenance	System Overview; Link Status, Page 2*

* Also displayed on Alarm Scanner and Alarm Display.

TABLE 6-2. PARAMETERS/ALARMS MONITORED FOR CPMAS (Continued)

<u>Parameter/Alarm</u>	<u>CRT Display Page</u>
<u>TlWB1:</u>	
FER	Link Status, Page 2; Line P.A., Page 4
Reframe	Link Status, Page 2; Link P.A., Page 4
Maintenance Voltages (+15 Vdc, -9 Vdc)	Maintenance Voltages
Office (Alarm)	System Overview; Link Status, Page 2*
<u>Site:</u>	
Flood (Simulated Alarm)	System Overview; Link Status, Page 2*
<u>Correlated Parameters:</u>	
BER Correlation	Link Status, Page 1
Control Reframe/Squelch	Link P.A., Page 3
Control Reframe/Hit	Link P.A., Page 3
Link Availability	Link P.A., Page 2

*Also displayed on Alarm Scanner and Alarm Display.

Verification of the above listed parameters and alarms with regard to their presence and/or accuracy was accomplished in the validation phase of field tests. Refer to the individual validation test results in Section II of the Field Test and Evaluation Report.

With respect to the utility and effectiveness of these particular alarms and parameters that were selected for use in monitoring the Ft. Huachuca-to-Site Sibyl digital transmission test link, it is not practical to discuss them all, but several samples of alarms and of different parameter types will be taken from test scenarios.

Following the examples above are several remarks regarding the completeness of the alarms/parameters monitored for CPMAS and some considerations for improvement.

Any scenario involving loss of service created by a major alarm condition in any of the communication system elements was immediately recognized by the tech controllers. In the first examples taken from Appendix P conducted on 6 June 1977, illustrating one of the major equipment alarm conditions, a fuse was removed from TlWB1 at Ft. Huachuca (HUA) at 0857 hours. The tech controller's

PROCEDURE	DATE	TIME
P1. At ^{HVA} SBL , remove the CONV fuse on the Power and Alarm panel of the TLWB1. Record the time.	6-6-77	0857
P2. At completion of the test, replace fuse in TLWB1 equipment.	6-6-77	0920

CONDUCTED BY C. L. Christner 6-6-77
 OBSERVED BY _____

DATEC SYSTEM EVALUATION WORKSHEET

OBSERVANCE (key points only)	PRINTOUT REF (ATTACH)	DATE	TIME
Start new day, with all systems on "A", and all fivers.. Systemdata attached.////RR	1-4/6 June 77	6/6	0850
CRT display shows RED flag on TLWEL both here and a t SEL..Chking further ATT.////RR	5/6 June 77		0857
Problem isolated to bad TLWEL here a t HUA, caused by +15 and +12 Vdc pwr supply...Maintenance a dvsd to chker the TLWEL (here at HUA).////RR	6/6 June 77		0903
Problem Resolved.....Isolated to blown fuse in the TLWEL at HUA.. Maintenance replaced same and all fivers A TT.....////RR	6/6 June 77		0910
<p>TECH CONTROLLER <u>DBS.</u></p> <p>OBSERVED BY <u>(P)</u></p>			

6 JUNE #2

AS-2

		LINK STATUS		TIME 157/0342:19	
	CY-104.....	TIWBI.....	
		HUA	SBL	HUA	SBL
ALARM	SERVICE	.	.	OFFICE	.
	REMOTE	.	.		.
STATUS	MAINT	.	.	MAINT	.
PARAMETER	CHANNEL	.	.	FER <1.0E-6	<1.0E-6
		.	.	REFRAME	.
SITE ALARMS	ENTRY	.	.		
	FIRE	.	.		
	AC PWR	.	.		
	BATTERY	.	.		
	W.A. PR	.	.		
	W.G. HV	.	.		
	FLOOD	.	.		

PAGE 2

IQ-006

		LINK PERFORMANCE ASSESSMENT - RADIOS						TIME 157/0343:12	
		LAST SCAN	LAST HR MEAN	LAST 24 HR MEAN	LAST 24 HR DEV	LAST 30 DAYS MEAN	LAST 30 DAYS DEV	LAST 30 MTHS MEAN	LAST 30 MTHS DEV
HUA	RSLMAR	30.778	29.097	29.417	.98489	29.669	0.0	-----	DB
A	EYEMAR	15.014	15.014	9.2879	.53255	9.4032	0.0	-----	DB
	RSLAVL	1.0000	1.0000	1.0000	-----	1.0000	-----	-----	RATE
	EYEA VL	1.0000	1.0000	1.0000	-----	1.0000	-----	-----	RATE
	EYEHIT	0.0	0.0	.02960	.12316	.11355	0.0	-----	/SC
HUA	RSLMAR	29.094	28.168	29.651	3.1601	29.577	0.0	-----	DB
B	EYEMAR	3.0369	3.0369	-----	-----	4.3615	2.2521	-----	DB
	RSLAVL	1.0000	1.0000	0.9970	-----	.96622	-----	-----	RATE
	EYEA VL	1.0000	1.0000	-----	-----	0.9968	-----	-----	RATE
	EYEHIT	.14133	.14133	-----	-----	5.3953	5.6949	-----	/SC
SBL	RSLMAR	39.250	39.187	39.614	3.0482	40.778	0.0	-----	DB
A	EYEMAR	13.369	11.755	12.678	1.0145	12.896	0.0	-----	DB
	RSLAVL	1.0000	1.0000	1.0000	-----	1.0000	-----	-----	RATE
	EYEA VL	1.0000	1.0000	.95783	-----	1.0000	-----	-----	RATE
	EYEHIT	.01169	.00584	5.0724	17.184	.00095	0.0	-----	/SC
SBL	RSLMAR	35.000	35.611	34.429	3.3400	35.794	0.0	-----	DB
B	EYEMAR	9.2973	9.2973	12.572	1.7866	12.917	0.0	-----	DB
	RSLAVL	1.0000	1.0000	1.0000	-----	1.0000	-----	-----	RATE
	EYEA VL	1.0000	1.0000	.98795	-----	1.0000	-----	-----	RATE
	EYEHIT	0.0	0.0	8.4244	28.091	.00690	0.0	-----	/SC

6 JUNE #3

MAC-3-01-06 LINK PERFORMANCE ASSESSMENT - RADIOS TIME 157/0844:14

	LAST SCAN	LAST HR MEAN	LAST 24 HR MEAN	LAST 24 HR DEV	LAST 30 DAYS MEAN	LAST 30 DAYS DEV	LAST 30 MTHS MEAN	LAST 30 MTHS DEV	
HUA EYEVOL	-3.6200	-3.6200	-4.1290	.05764	-4.1199	0.0			VLTS
RXSQH	0.0	0.0	1.0000		0.0				RTE
HUA EYEVOL	-4.7700	-4.7700			-4.5289	.22754			VLTS
B RXSQH	0.0	0.0			11.000				RTE
HUA LNKAVL	1.0000	1.0000	1.0000		0.0966				RTE
SBL EYEVOL	-3.7600	-3.9050	-3.3287	.11569	-3.8016	0.0			VLTS
A RXSQH	0.0	0.0	9.0000		0.0				RTE
SBL EYEVOL	-4.1300	-4.1300	-3.8506	.24086	-3.8006	0.0			VLTS
B RXSQH	0.0	0.0	4.0000		0.0				RTE
SBL LNKAVL	1.0000	1.0000	1.0000		1.0000				RTE

AS-1 LINK PERFORMANCE ASSESSMENT - T1-4000 TIME 157/0845:06

	LAST SCAN	LAST HR MEAN	LAST 24 HR MEAN	LAST 24 HR DEV	LAST 30 DAYS MEAN	LAST 30 DAYS DEV	LAST 30 MTHS MEAN	LAST 30 MTHS DEV	
HUA FER	1.0E-15	3.3E-17			1.7E-10				RTE
A FERAVL	1.0000	1.0000			1.0000				RTE
CRFRM	0.0	0.0			1.3333	.94281			RTE
CR/SQH	0.0	0.0			0.0				RTE
CR/HIT	0.0	0.0			0.0				RTE
HUA FER	1.0E-15	6.7E-17	1.4E-18						RTE
A FERAVL	1.0000	1.0000	1.0000						RTE
CRFRM	0.0	0.0			4.0000	3.2660			RTE
CR/SQH	0.0	0.0			0.0				RTE
CR/HIT	0.0	0.0			0.0				RTE
SBL FER	1.0E-15	1.0E-16	6.3E-9		5.1E-10				RTE
A FERAVL	1.0000	1.0000	1.0000		1.0000				RTE
CRFRM	0.0	0.0	6.0000		1.0000	0.0			RTE
CR/SQH	0.0	0.0	4.0000		0.0				RTE
CR/HIT	0.0	0.0	5.0000		0.0				RTE
SBL FER	5.2E-10	1.7E-11	3.9E-6						RTE
B FERAVL	1.0000	1.0000	1.0000						RTE
CRFRM	0.0	0.0	4.0000		1.0000	0.0			RTE
CR/SQH	0.0	0.0	3.0000		0.0				RTE
CR/HIT	0.0	0.0	3.0000		0.0				RTE

6 JUNE # 4

IQ-007

LINK PERFORMANCE ASSESSMENT - TIWBI								TIME 151/0846:08	
		LAST SCAN	LAST HR MEAN	LAST 24 HR MEAN	LAST 24 HR DEV	LAST 30 DAYS MEAN	LAST 30 DAYS DEV	LAST 30 DAYS MEAN	LAST 30 DAYS DEV
H	FER	1.2E-14	1.2E-15	7.5E-9	-----	1.0E-10	-----	-----	-----
	RFRM	0.0	0.0	9.0000	-----	12.000	0.0	-----	-----
SBL	FER	1.2E-14	4.0E-16	-----	-----	1.2E-9	-----	-----	-----
	RFRM	0.0	0.0	-----	-----	2.0000	2.1602	-----	-----

MAC-3-07-12

MAINTENANCE VOLTAGES - HUA										TIME 151/0847:00		
NO.	NAME	VOLTS	C	RH	AH	CG	AL	RL	MEAN	DEV	INITIAL	DATE
01	TIWBI+15	15.6	G	16.5	15.7	15.0	14.2	13.5	15.5	.043		153/0907
02	TIWBI+12	12.4	G	13.2	12.6	12.0	11.4	10.8	12.4	.008		153/0907
03	T14000+5	4.96	G	5.50	5.25	5.00	4.75	4.50	4.95	.002		153/0907
04	T14000-6	-6.08	G	-5.40	-5.70	-6.00	-6.30	-6.60	-6.08	0		153/0907
05	RADIO+24	24.0	G	26.4	25.2	24.0	22.3	21.6	23.9	.014		153/0907
06	RADIO-20	-19.9	G	-18.0	-19.0	-20.0	-21.0	-22.0	-19.9	.010		153/0907

MAINTENANCE VOLTAGES - SBL										TIME 151/0847:34		
NO.	NAME	VOLTS	C	RH	AH	CG	AL	RL	MEAN	DEV	INITIAL	DATE
01	TIWBI+15	15.2	G	16.5	15.7	15.0	14.2	13.5	15.1	.016		153/0911
02	TIWBI+12	12.3	G	13.2	12.6	12.0	11.4	10.8	12.3	.007		153/0911
03	T14000+5	4.95	G	5.50	5.25	5.00	4.75	4.50	4.95	0		153/0911
04	T14000-6	-6.04	G	-5.40	-5.70	-6.00	-6.30	-6.60	-6.04	.004		153/0911
05	RADIO+24	24.1	G	26.4	25.2	24.0	22.3	21.6	24.1	.004		153/0911
06	RADIO-20	-20.1	G	-18.0	-19.0	-20.0	-21.0	-22.0	-20.1	2.3E		153/0911

AS-1

SYSTEM OVERVIEW

TIME 15170357:59

	HUA	SBL
RADIO A	.	.
B	.	.
MUX SW	.	.
A	.	.
B	.	.
CY104	.	.
	.	.
	.	.
	.	.
	.	.
	.	.
	.	.
TIWBI	.R01<><>01R.	.
	.	.
.....		
TELEMETRY.	.	.
SITE	.	.

#5, 6 June 77

IQ 37	LINK STATUS		TIME 15170359:27
CY-104.....	TIWBI.....
	HUA	SBL	HUA SBL
ALARM	SERVICE	.	OFFICE * . *
	REMOTE	.	.
		.	.
STATUS	MAINT	.	MAINT
		.	.
PARAMETER	CHANNEL	.	FER <1.0E-6 <1.0E-6
		.	REFRAME
		.	.
SITE	ENTRY	.	
ALARMS	FIRE	.	
	AC PWR	.	
	BATTERY	.	
	W.A. PR	.	
	W.G. HV	.	
	FLOOD	.	

MAC-I-18-23

MAINTENANCE VOLTAGES - HUA

TIME 157/0913:50

NO.	NAME	VOLTS	C	RH	AH	CG	AL	RL	MEAN	DEV	DATE
01	TIWB1+15	.066	R	16.5	15.7	15.0	14.2	13.5	0.0E	0.0E	153/0907
02	TIWB1+12	.070	R	13.2	12.6	12.0	11.4	10.8	0.0E	0.0E	153/0907
03	TI4000+5	4.96	G	5.50	5.25	5.00	4.75	4.50	0.0E	0.0E	153/0907
04	TI4000-6	-6.08	G	-5.40	-5.70	-6.00	-6.30	-6.60	0.0E	0.0E	153/0907
05	RADIO+24	23.9	G	26.4	25.2	24.0	22.8	21.6	0.0E	0.0E	153/0907
06	RADIO-20	-19.9	G	-18.0	-19.0	-20.0	-21.0	-22.0	0.0E	0.0E	153/0907

#6, 6 June 77

MAC-I-18-23

MAINTENANCE VOLTAGES - HUA

TIME 157/0910:23

NO.	NAME	VOLTS	C	RH	AH	CG	AL	RL	MEAN	DEV	DATE
01	TIWB1+15	15.4	G	16.5	15.7	15.0	14.2	13.5	0.0E	0.0E	153/0907
02	TIWB1+12	12.4	G	13.2	12.6	12.0	11.4	10.8	0.0E	0.0E	153/0907
03	TI4000+5	4.95	G	5.50	5.25	5.00	4.75	4.50	0.0E	0.0E	153/0907
04	TI4000-6	-6.08	G	-5.40	-5.70	-6.00	-6.30	-6.60	0.0E	0.0E	153/0907
05	RADIO+24	23.9	G	26.4	25.2	24.0	22.8	21.6	0.0E	0.0E	153/0907
06	RADIO-20	-19.9	G	-18.0	-19.0	-20.0	-21.0	-22.0	0.0E	0.0E	153/0907

log and supporting display page printouts indicate immediate recognition of the problem on the System Overview Display; verification of the T1WB1 Office Alarm on Link Status, Page 2; and final fault isolation to the T1WB1 power supply utilizing the HUA Maintenance Voltage display.

Illustrating the usefulness of the Maintenance and in-service status indications in providing insight into operational problems, Appendix O scenario, 2 June 1977 is used. This scenario simulates a failure resulting from human error. At Site Sibyl (SBL), the T1-4000 A Maintenance switch is placed ON, and at the same time the XFER to STDB switch on the RX switch module is operated. This signifies the intent by SBL personnel to perform maintenance on the T1-4000 A unit. The tech controller is alerted as will be noted by his log entry at 1347. He uses Maintenance and In-Service information available to him on the System Overview and Link Status, Page 1, displays. At 1350, simulating the maintenance error, the Interface card is extracted from the Standby T1-4000 causing a loss of service. The problem was then quickly isolated using major alarm information on the System Overview and Link Status displays.

Although both are radio parameters, RSL Margin and Eye Margin are used to isolate different kinds of problems which have similar effects on the communication system. As an example of the utility of these two parameters, consider Appendix L, scenario conducted on 8 June 1977. In this scenario, an attenuator in the IF circuit of the "A" radio receiver was used to cause noise figure degradation. In order to prevent the attenuation added to the IF from causing a lower RSL, the AGC from RX A was disconnected from the DATEC monitor point. The monitor point for "A" AGC was then jumpered to the monitor point for "B" AGC. The result is then a degraded noise figure, but no reduction in RSL Margin. The problem was correctly pinpointed to the A receiver by using primarily the Link Status, Page 1, and Link P.A., Page 1 displays.

Utilization of the RSL Margin parameter is clearly illustrated in the Appendix N scenario. This is a two-part test which deals with simulated antenna malalignment. Through the use of attenuators in the waveguides, faulty alignment of just the Transmit/RX A antenna or of both the antennas in the space diversity system may be simulated. Tech Controller work sheets dated 6/1/77 and 6/3/77 illustrate use of the Link P.A., Page 1, display, which has all four RSL Margins (HUA A and B, and SBL A and B) displayed to distinguish between the two types of problems-- single antenna malalignment or both antennas (or tower) malaligned.

As a final example of parameter usefulness, Appendix U scenario, 10 June 1977, depicts use of Frame Error Rate (FER) in fault isolation. An excessively high FER is noted as indicated by the 0807 entry in the Tech Controller's log. The fact that RSL and Eye Margins remain high, point to the High Level Multiplexer as the discrepant area.

PROCEDURE	DATE	TIME
01. At SRL, perform the following steps: <ul style="list-style-type: none"> o Place T1-4000 A MAINT switch on the MAINTENANCE panel of the ARS rack ON. e Place the XPER to STDE switch up on the T1-4000 4034 RX Switch module. • Pull the 4091 Interface Unit from the standby T1-4000. 	6-2-77	1345 1345 1350
02. At completion of test, restore the equipment to baseline configuration.	6-2-77	1420

CONDUCTED BY

P. J. Christy

6-2-77

OBSERVED BY

OBSERVANCE (key points only)	PRINTOUT REF (ATTACH)	DATE	TIME
Awaiting test "3" ...//RR			1300
At 1328, showed amber condition on HVA TL1E1 due to ERR and Reframe... No other indication of problem..ATT, display shows clear.. Will await further events before running any further checks...//RR	11/2 June 77		1345
From CRT display, looks like S L pulling maint on "A" side of TL4000.. He now in service on the "B" side...//RR	12/2 June 77		1347
Now showing on CRT, that "B" side of TL4000 at SBL has failed...chkng with them now...//RR	12/2 June 77		1353
Requested maint at SBL to switch back to "A" side of TL-4000, to restore service, attempting to isolate prob. with "B" side ATT...//RR	13/2 June 77		1358
Requested maint at SBL chker out "B" side of TL-4000... Unable to determine what actually is wrong with it...//RR			1410
Problem resolved.. Maint at SEL pulled wrong module ???//RR ///Replaced same...//RR	14/2 June 77		1420
<p>TECH CONTROLLER _____</p> <p>OBSERVED BY _____</p>			

#11 2 June '61

AS-1			SYSTEM OVERVIEW	TIME 153/1328:29
RADIO A	HUA	SBL		
B	.	.		
MUX SW	.	.		
A	.	.		
B	.	.		
CY104	.	.		
	.	.		
	.	.		
	.	.		
	.	.		
	.	.		
	.	.		
	.	.		
	.	.		
	.	.		
	.	.		
T1WB1	.A01<	.		
	.	.		
	.	.		
TELEMETRY.			
SITE	:	:	:	

IQ-005		LINK STATUS	TIME 153/1329:24
	CY-104.....T1WB1.....
		HUA SBL	HUA SBL
ALARM	SERVICE	.	OFFICE
		.	.
	REMOTE	.	.
		.	.
		.	.
STATUS	MAINT	.	MAINT
		.	.
PARAMETER	CHANNEL	.	FER 2.7E-5 R.<1.0E-6
		.	REFRAME *
		.	.
SITE ALARMS	ENTRY	.	
	FIRE	.	
	AC PWR	.	
	BATTERY	.	
	N.A. PR	.	
	V.G. HV	.	
	FLOOD	.	

PAGE 2

MUX SW B
A
B
CY104

~~#12~~ 12
2 June 77

TIWBI

TELEMETRY.

SITE
MAC-1-13-17

LINK STATUS
.....T1-4000.....
HUA SBL

TIME 153/1350:00
.....RADIO.....
HUA SBL

ALARM	SW MAJOR	.	.	TX PROB	.	.
	SW MINOR	.	*	RX PROB	.	.
	MAJOR
STATUS	TX IN SVC	A	A	TX IN SVC	A	A
	RX IN SVC	A	B	RX IN SVC	A	A
	MAINT	.	A	MAINT	.	.
PARAMETER	FER	<1.0E-7	<1.0E-7	RX SQUELCH	.	.
	CRFRM	.	.	RSL MARGIN	27.486	40.444
				EYE MARGIN	9.4021	12.573
	BER COR	NO DATA	NO DATA	EYE AMPL	-8.8065	-8.9677
				EYE HITS	0.0	0.0
				DER BER	2.2E-11	4.7E-13

PAGE 1

MAC-3-13-17

SYSTEM OVERVIEW

TIME 153/1353:24

RADIO A
B
MUX SW A
B
CY104

TIWBI

MAJOR ALARM

TELEMETRY.

SITE

#13 2 June 77

MAC 5-13-17

		LINK STATUS		TIME 153/1358:52	
	T1-4000.....	RADIO.....	
		HUA	SBL	HUA	SBL
ALARM	SW MAJOR
	SW MINOR
	MAJOR	.	B	.	.
STATUS	TX IN SVC	A	A	A	A
	RX IN SVC	A	A	A	A
	MAINT
PARAMETER	FER	<1.0E-7	<1.0E-7	.	.
	CRFRM
	BER COR	NO DATA	NO DATA	.	.
				TX PROB	.
				RX PROB	.
				TX IN SVC	A
				RX IN SVC	A
				MAINT	.
				RX SQUELCH	.
				RSL MARGIN	29.615 . 40.444
				EYE MARGIN	9.6090 . 12.573
				EYE AMPL	-8.8065 . -8.9677
				EYE HITS	9.7280 R. . 0.0
				DER BER	1.7E-11 . 4.7E-13

PAGE 1

AS-1

		LINK STATUS		TIME 153/1411:03	
	T1-4000.....	RADIO.....	
		HUA	SBL	HUA	SBL
ALARM	SW MAJOR
	SW MINOR
	MAJOR	.	B	.	.
STATUS	TX IN SVC	A	A	A	A
	RX IN SVC	A	A	A	A
	MAINT
PARAMETER	FER	<1.0E-7	<1.0E-7	.	.
	CRFRM
	BER COR	NO DATA	NO DATA	.	.
				TX PROB	.
				RX PROB	.
				TX IN SVC	A
				RX IN SVC	A
				MAINT	.
				RX SQUELCH	.
				RSL MARGIN	29.167 . 40.222
				EYE MARGIN	9.7148 . 12.573
				EYE AMPL	-8.8965 . -8.9677
				EYE HITS	0.0 . 0.0
				DER BER	1.5E-11 . 4.7E-13

PAGE 1

#14
2 June 77

MAC-3-07-12

		LINK STATUS		TIME 153/1420:58	
	TI-4000.....	RADIO.....	
		HUA	SBL	HUA	SBL
ALARM	SW MAJOR
	SW MINOR
	MAJOR
STATUS	TX IN SVC	A	A	A	A
	RX IN SVC	A	A	A	A
	MAINT
PARAMETER	FER	<1.0E-7	<1.0E-7	.	.
	CRFRM
	BER COR	NO DATA	NO DATA	.	.
				RSL MARGIN	27.390 . 42.222
				EYE MARGIN	9.7148 . 12.573
				EYE AMPL	-8.8065 . -8.9677
				EYE HITS	0.0 . 0.0
				DER BER	1.5E-11 . 4.7E-13
					PAGE 1

PROCEDURE	DATE	TIME
<p>L1. At HUA, connect attenuators (X1 and X10) between Equalizer and IF in RX A as shown in Figure L-1.</p>		
<p>L2. With power off the radio and DATEC equipment at HUA, de solder the AGC A lead coming from the radio to the Analog Scanner at Analog Scanner TB1-13. Connect a jumper wire between TB1-13 and 18. Reapply power; put equipment into operation.</p>		
<p>L3. Introduce attenuation at the approximate rate of ^{two} one dB every 5 minutes. Do not drop below squelch threshold. Record time when each addition of attenuation is made:</p>		
<p>NOTE: Start with attenuator set to 25 dB</p>	<p>6/8/77</p>	<p>1240 1245 1248 1252 1258 1304 1310</p>
<p>L4.) Restore equipment to base line condition at completion of test.</p>	<p>6/8/77</p>	<p>1336</p>
<p>CONDUCTED BY <u>C. L. Christy 6-8-77</u></p>		
<p>OBSERVED BY _____</p>		

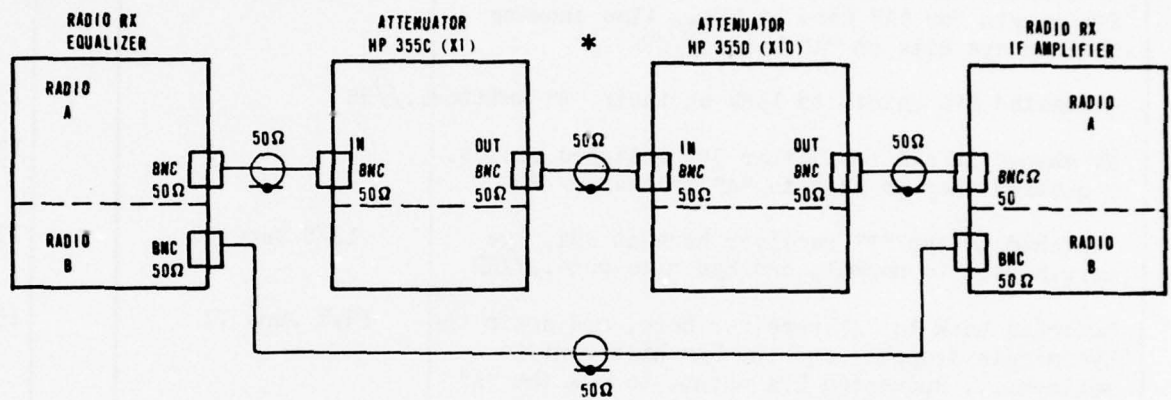

* ALTERNATE ATTENUATORS WHICH MAY BE USED: -
WEINSCHL ENGINEERING, MODEL 933

Figure L-1. Test Configuration,
Receiver A Versus B Noise Degradation

OBSERVANCE (key points only)	PRINTOUT REF (ATTACH)	DATE	TIME
Systems green ATT....///RR		6/8	1235
CRT display shows the "B" radio at SBL in amber condition...///RR	10/8 June 77		1251
LS, pg # 1 now shows a drastic drop in the Eye margin here at HUA.. also showing Amber for Eye hits here at HUA.. Chking further.///RR	10/8 June 77		1255
LP display now shows further degradation in the Eye margin for "A" here at HUA.. Also showing Maximum eye hits on "A" here...///RR	11/8 June 77		1304
Requested SBL maint. to lock on their "B" xmitter...///RR			1305
No change in status, after SBL switched radios. Requested they go back to "A" xmitter...///RR			1325
Switched to the "B" receiver here at HUA, Eye margin back to normal, and Eye hits gone...///RR	12/8 June 77		1331
Switched back to "A" receiver here, and again the Eye margin dropped, and the Eye hits went to maximum.... Requested HUA maint, to chk the "A" receiver... Switched back to "B" receiver to restore service.///RR	13/8 June 77		1335
Maintenance advsd they replaced the IF in the "A" receiver, and that it is now good...After chking, found that still seeing maximum eye hits and turned the receiver back to maint...///RR			1345
Maintenance advsd they re-aligned the IF, and "A" now looking good..Switched system back to the "A" side and all fivers..RR			1355
Problem isolated to bad IF within the "A" receiver at HUA.. Maintenance replaced same...///RR			
<p>NOTE: Amber condition at SBL, noted at 1252, appeared to be caused by a drop in the "B" RSL margin.. This however cleared within approx 5 minutes, and did not affect the system..///RR</p>			
TECH CONTROLLER _____			
OBSERVED BY _____			
		244	

MAS

SYSTEM OVERVIEW

TIME 159/1251:53

	HUA	SBL
RADIO A	.	.
B	.	.
MUX SW	.	.
A	.	.
B	.	.
CY104	.	.
	.	.
	.	.
	.	.
	.	.
TIWBI	.	.
	.	.
TELEMETRY.
SITE	.	.

>SA.

#10 8 June 77

IQ-007

LINK STATUS

TIME 159/1255:08

.....TI-4000.....

.....RADIO.....

		HUA	SBL		HUA	SBL
ALARM	SW MAJOR		.	TX PROB		.
	SW MINOR		.	RX PROB		.
	MAJOR		.			.
STATUS	TX IN SVC	A	.	TX IN SVC	A	A
	RX IN SVC	A	.	RX IN SVC	A	A
	MAINT		.	MAINT		.
PARAMETER	FER	<1.0E-7	.	RX SQUELCH		.
	CRFRM		.	RSL MARGIN	29.423	. 40.444
			.	EYE MARGIN	4.2393	. 13.714
	BER COR	NO DATA	.	EYE AMPL	-3.8065	. -8.9677
			.	EYE HITS	.59244	A. 0.0
			.	DER BER	3.7E-9	. 9.7E-14

PAGE 1

11 8 June 27

MAC-1-08-10		LINK PERFORMANCE ASSESSMENT - RADIOS						TIME 159/1304:31		
	LAST SCAN	LAST HR	LAST 24 HR	LAST 24 HR	LAST 30 DAYS	LAST 30 DAYS	LAST 30 MTHS	LAST 30 MTHS		
		MEAN	MEAN	DEV	MEAN	DEV	MEAN	DEV		
F	RSLMAR 34.000	29.956	6.1862	11.083	25.066	9.1740	-----	-----	DB	
A	EYEMAR-5.1056	8.6336	.38853	5.8017	9.1217	4.2871	-----	-----	DB	
	RSLAVL 1.0000	1.0000	.36145	-----	.84815	-----	-----	-----	RATE	
	EYEA VL 0.0	1.0000	.35878	-----	.85143	-----	-----	-----	RATE	
	EYEHIT 364.09	.29622	178.34	109.27	33.108	66.134	-----	-----	/SC	
HUA	RSLMAR 28.932	29.133	32.494	1.7115	30.682	2.0236	-----	-----	DB	
B	EYEMAR 5.5670	5.6637	9.8185	2.5079	6.5218	2.7858	-----	-----	DB	
	RSLAVL 1.0000	1.0000	0.9959	-----	.98701	-----	-----	-----	RATE	
	EYEA VL 1.0000	1.0000	1.0000	-----	0.9978	-----	-----	-----	RATE	
	EYEHIT 0.0	0.0	0.0	0.0	4.1507	4.9477	-----	-----	/SC	
SBL	RSLMAR 41.667	38.903	38.538	1.1887	39.132	1.1168	-----	-----	DB	
A	EYEMAR 13.714	13.714	13.544	.34402	12.769	.56043	-----	-----	DB	
	RSLAVL 1.0000	1.0000	1.0000	-----	1.0000	-----	-----	-----	RATE	
	EYEA VL 1.0000	1.0000	1.0000	-----	0.9956	-----	-----	-----	RATE	
	EYEHIT 0.0	0.0	.01710	.07455	3.0423	4.0440	-----	-----	/SC	
SBL	RSLMAR 35.583	33.527	33.857	.77144	34.701	.86241	-----	-----	DB	
B	EYEMAR 14.660	14.421	13.562	.38009	12.334	1.5540	-----	-----	DB	
	RSLAVL 1.0000	1.0000	1.0000	-----	1.0000	-----	-----	-----	RATE	
	EYEA VL 1.0000	1.0000	1.0000	-----	0.9957	-----	-----	-----	RATE	
	EYEHIT 0.0	0.0	0.0	0.0	1.6863	3.3690	-----	-----	/SC	

131°
 90° to 180°
 of SOL

1325Z

BEST AVAILABLE COPY

#12 8 June 77

MAC-1-08-10 LINK PERFORMANCE ASSESSMENT - RADIOS TIME 152/1318:25

		LAST SCAN	LAST HR	LAST 24 HR	LAST 30 DAYS	LAST 30 DAYS	LAST 30 DAYS	
			MEAN	MEAN	MEAN	MEAN	MEAN	
HJA	RSLMAR	22.423	29.896	6.1996	11.111	25.466	9.1744	DB
A	EYEMAR	18.962	3.1252	.38853	5.8017	9.1217	4.2671	DB
	RSLAVL	1.0000	1.0000	.34025		.84815		RATE
	EYEA VL	0.0	.66667	.35878		.85143		RATE
	EYEHIT	364.00	121.56	178.34	192.27	33.198	66.134	/SC
HJA	RSLMAR	26.625	27.745	32.488	1.7229	33.622	2.3236	DB
B	EYEMAR	11.562	11.562	9.8185	2.5081	6.5213	2.7853	DB
	RSLAVL	1.0000	1.0000	0.0253		.93731		RATE
	EYEA VL	1.0000	1.0000	1.0000		0.0273		RATE
	EYEHIT	0.0	0.0	0.0	0.0	4.1507	4.9477	/SC
SBL	RSLMAR	32.750	32.750	38.634	1.1282	32.132	1.1168	DB
A	EYEMAR	13.714	13.714	13.584	.31364	12.769	.56043	DB
	RSLAVL	1.0000	1.0000	1.0000		1.0000		RATE
	EYEA VL	1.0000	1.0000	1.0000		0.0256		RATE
	EYEHIT	0.0	0.0	.01719	.07455	3.4423	4.0444	/SC
SBL	RSLMAR	33.455	33.455	33.080	.75331	34.701	.86241	DB
B	EYEMAR	14.661	14.421	13.562	.38009	12.334	1.5540	DB
	RSLAVL	1.0000	1.0000	1.0000		1.0000		RATE
	EYEA VL	1.0000	1.0000	1.0000		0.0257		RATE
	EYEHIT	0.0	0.0	0.0	0.0	1.6863	3.3690	/SC

MAS LINK STATUS TIME 159/1331:45

.....T1-4000.....

		HJA	SBL		HJA	SBL
ALARM	SW MAJOR		.	TX PROB		.
	SW MINOR		.	RX PROB		.
	MAJOR		.			.
STATUS	TX IN SVC	A	A	TX IN SVC	A	A
	RX IN SVC	A	A	RX IN SVC	B	A
	MAINT		.	MAINT		.
PARAMETER	FER	<1.0E-7	<1.0E-7	RX SQUELCH		.
	CRFRM		.	RSL MARGIN	29.453	.38.100
	BER COR	NO DATA	.NO DATA	EYE MARGIN	5.5670	.13.714
				EYE AMPL	-9.0741	-.8.9355
				EYE HITS	0.0	.0.0
				DER BER	1.1E-9	.9.7E-14

PAGE 1

#13 8 June 27

MAS

LINK STATUS
.....T1-4000.....
HUA SBL

TIME 159/1333:19
.....RADIO.....
HUA SBL

ALARM	SW MAJOR	.	.	TX PROB	.	.
	SW MINOR	.	.	RX PROB	.	.
	MAJOR
STATUS	TX IN SVC	A	A	TX IN SVC	A	A
	RX IN SVC	A	A	RX IN SVC	A	A
	MAINT	.	.	MAINT	.	.
PARAMETER	FER	<1.0E-7	<1.0E-7	RX SOUQLCH	.	*
	CRFRM	.	.	RSL MARGIN	26.610	38.600
	BER COR	NO DATA	NO DATA	EYE MARGIN	-10.776	13.714
				EYE AMPL	-8.5484	-8.9355
				EYE HITS	364.09	0.0
				DER BER	1.1E-9	9.7E-14

PAGE 1

MAS

LINK STATUS
.....T1-4000.....
HUA SBL

TIME 159/1335:12
.....RADIO.....
HUA SBL

ALARM	SW MAJOR	.	.	TX PROB	.	.
	SW MINOR	.	.	RX PROB	.	.
	MAJOR
STATUS	TX IN SVC	A	A	TX IN SVC	A	A
	RX IN SVC	A	A	RX IN SVC	B	A
	MAINT	.	.	MAINT	.	.
PARAMETER	FER	<1.0E-7	<1.0E-7	RX SOUQLCH	.	*
	CRFRM	.	.	RSL MARGIN	28.447	38.600
	BER COR	NO DATA	NO DATA	EYE MARGIN	5.5670	13.714
				EYE AMPL	-9.0741	-8.9355
				EYE HITS	0.0	0.0
				DER BER	1.1E-9	9.7E-14

PAGE 1

PROCEDURE	DATE	TIME
<u>Reciprocal Path Problem</u>		
N1. Insert 10dB of attenuation between equalizer and IF in the A and B receivers at both HUA and SBL. <i>(Accomplished by inserting 10dB of attenuation in both transmit and RX A waveguides @ SBL)</i>	6-3-77	0845
<u>Transmit Antenna Only at Sibyl</u>		
N2. Insert 10dB of attenuation between equalizer and IF in the A and B receivers at HUA and the D receiver only at SBL. <i>(Accomplished by inserting 10dB of attenuation in transmit waveguide @ SBL)</i>	6-1-77	0832
N3. Restore equipment to baseline configuration	6-1-77	0900
	6-3-77	1015
CONDUCTED BY	<i>A. L. Christy</i> 6-1-77 / 6-3-77	
OBSERVED BY	_____	

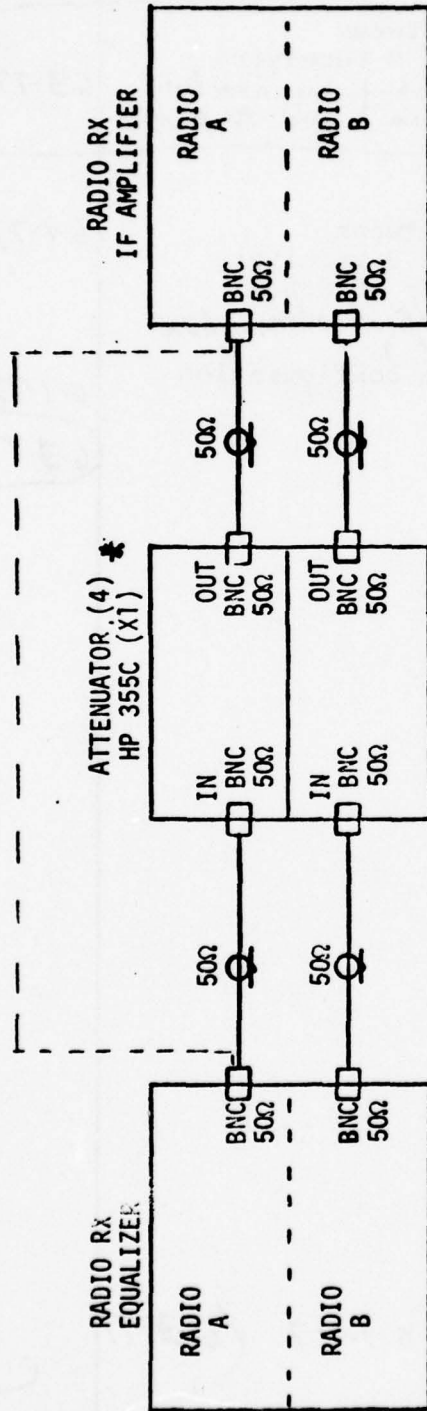

NOTE: Simultaneously at both HUA and SBL for step N1.
Both receivers at HUA and B receiver only at SBL for step N2.

Figure N-1. Test Configuration, Antenna Misalignment

* Alternate attenuators which may be used :-
WEINSCHEL ENGINEERING, Model 933.

DATEC SYSTEM EVALUATION WORKSHEET

OBSERVANCE (key points only)	PRINTOUT REF (ATTACH)	DATE	TIME
Collecting system data, and checking EPL thresholds on "A" and "B" regions at HUA....//RR No alarms or faulty indications are present...//RR	L-3/1 June 77	6/1	0830
Showing Ctl Refrm on TL000, and Refrm on TL01 at SEL....//RR			0833
Showing at SEL, amber on TL01 and TL000, and at HUA amber on both radio recvr...B recvr at SEL also amber....//RR			0835
SEL margin at HUA is amber...Reframes on TL01 at SEL cleared...//RR			0836
SEL on both "A" & "B" at HUA are amber...//RR Suspect output cur prob at SEL.. Chking further....//RR			0838
SEL on both recves at HUA still down.. Also showing low SEL on "B" radio at SEL...??//RR	6/1 June 77		0845
Based on 0845 entry, appears to be antenna alignment at SEL...System is operating on space diversity, so alignment problem appears to be the cause of problem...//RR//transmit antenna at SEL...//RR Test # 1 for today complete...//RR			0851
<p>TECH CONTROLLER _____</p> <p>OBSERVED BY _____</p>			

RADIO A
 B
 UX SW
 A
 B
 CY104

#1
 1 June 77

TIWBI

TELEMETRY.

SITE

BEM-3-M0-12

LINK STATUS

TIME 152/0811:23

.....TI-4000.....
 HUA SBL

.....RADIO.....
 HUA SRL

ALARM

SW MAJOR
 SW MINOR

.
 .

TX PROB
 RX PROB

.
 .

STATUS

MAJOR
 TX IN SVC
 RX IN SVC

A . A
 A . A

TX IN SVC
 RX IN SVC

A . A
 A . A

PARAMETER

MAINT
 FER
 CRFRM

<1.0E-7 . <1.0E-7
 .

MAINT
 RX SQUELCH

.
 .

BER COR

NO DATA .NO DATA

RSL MARGIN 29.936 . 41.444
 EYE MARGIN 9.6090 . 13.714
 EYE AMPL -8.8065 . -8.9355
 EYE HITS 0.0 . .00449
 DER BER 1.7E-11 . 9.7E-14

PAGE 1

#AS

LINK STATUS

TIME 152/0812:33

.....CY-104.....

.....TIWBI.....

ALARM	SERVICE	HUA	SBL	OFFICE	HUA	SBL
	REMOTE
STATUS	MAINT	.	.	MAINT	.	.
PARAMETER	CHANNEL	.	.	FER <1.0E-6	.	<1.0E-6
		.	.	REFRAME	.	.
SITE ALARMS	ENTRY	.	.			
	FIRE	.	.			
	AC PWR	.	.			
	BATTERY	.	.			
	W.A. PR	.	.			
	W.G. HV	.	.			
	FLOOD	.	.			

PAGE 2

#2 1JUN77

AS-2

LINK PERFORMANCE ASSESSMENT - RADIOS

TIME 152/0814:11

		LAST SCAN	LAST HR MEAN	LAST 24 HR MEAN	LAST 30 DAYS DEV	LAST 30 DAYS MEAN	LAST 30 DAYS DEV	LAST 30 MTHS MEAN	LAST 30 MTHS DEV	
HUA	RSLMAR	29.615	29.776	-----	-----	-----	-----	-----	-----	DB
A	EYEMAR	9.6093	9.6090	-----	-----	-----	-----	-----	-----	DB
	RSLAVL	1.0000	1.0000	-----	-----	-----	-----	-----	-----	RATE
	EYEA VL	1.0000	1.0000	-----	-----	-----	-----	-----	-----	RATE
	EYEHIT	0.0	0.0	-----	-----	-----	-----	-----	-----	/SC
HUA	RSLMAR	30.846	31.095	-----	-----	-----	-----	-----	-----	DB
B	EYEMAR	4.1460	-----	-----	-----	-----	-----	-----	-----	DB
	RSLAVL	1.0000	1.0000	-----	-----	-----	-----	-----	-----	RATE
	EYEA VL	1.0000	-----	-----	-----	-----	-----	-----	-----	RATE
	EYEHIT	293.09	-----	-----	-----	-----	-----	-----	-----	/SC
SBL	RSLMAR	41.444	41.444	-----	-----	-----	-----	-----	-----	DB
A	EYEMAR	13.714	13.714	-----	-----	-----	-----	-----	-----	DB
	RSLAVL	1.0000	1.0000	-----	-----	-----	-----	-----	-----	RATE
	EYEA VL	1.0000	1.0000	-----	-----	-----	-----	-----	-----	RATE
	EYEHIT	0.0449	0.0449	-----	-----	-----	-----	-----	-----	/SC
SBL	RSLMAR	34.200	34.200	-----	-----	-----	-----	-----	-----	DB
B	EYEMAR	14.065	-----	-----	-----	-----	-----	-----	-----	DB
	RSLAVL	1.0000	1.0000	-----	-----	-----	-----	-----	-----	RATE
	EYEA VL	1.0000	-----	-----	-----	-----	-----	-----	-----	RATE
	EYEHIT	0.0	-----	-----	-----	-----	-----	-----	-----	/SC

MAC-1-07-12

LINK PERFORMANCE ASSESSMENT - RADIOS

TIME 152/0815:37

		LAST SCAN	LAST HR MEAN	LAST 24 HR MEAN	LAST 24 HR DEV	LAST 30 DAYS MEAN	LAST 30 DAYS DEV	LAST 30 MTHS MEAN	LAST 30 MTHS DEV	
HUA	EYEVOL	-4.1000	-4.1000							VLTS
A	RXSQH	0.0	0.0							RTE
HUA	EYEVOL	-4.7200	-4.7200							VLTS
B	RXSQH	0.0	0.0							RTE
HUA	LNKAVL	1.0000	1.0000							RTE
SBL	EYEVOL	-3.7300	-3.7300							VLTS
A	RXSQH	0.0	0.0							RTE
SBL	EYEVOL	-3.7000								VLTS
B	RXSQH	0.0	0.0							RTE
SBL	LNKAVL	1.0000	1.0000							RTE

#3
1 JUN 77

IQ-005

LINK PERFORMANCE ASSESSMENT - T1-4000

TIME 152/0816:51

		LAST SCAN	LAST HR MEAN	LAST 24 HR MEAN	LAST 24 HR DEV	LAST 30 DAYS MEAN	LAST 30 DAYS DEV	LAST 30 MTHS MEAN	LAST 30 MTHS DEV	
HUA	FER	1.0E-15	3.3E-17							RTE
A	FERAVL	1.0000	1.0000							RTE
	CRFRM	0.0	0.0							RTE
	CR/SQH	0.0	0.0							RTE
	CR/HIT	0.0	0.0							RTE
HUA	FER	1.0E-15								RTE
B	FERAVL	1.0000								RTE
	CRFRM	0.0	0.0							RTE
	CR/SQH	0.0	0.0							RTE
	CR/HIT	0.0	0.0							RTE
SBL	FER	1.0E-15	3.3E-17							RTE
A	FERAVL	1.0000	1.0000							RTE
	CRFRM	0.0	0.0							RTE
	CR/SQH	0.0	0.0							RTE
	CR/HIT	0.0	0.0							RTE
SBL	FER	1.0E-15								RTE
B	FERAVL	1.0000								RTE
	CRFRM	0.0	0.0							RTE
	CR/SQH	0.0	0.0							RTE
	CR/HIT	0.0	0.0							RTE

4 1 June 77

AS-2

LINK PERFORMANCE ASSESSMENT - TIWBI								TIME 152/0818:00	
	LAST SCAN	LAST HR MEAN	LAST 24 HR MEAN	LAST 24 HR DEV	LAST 30 DAYS MEAN	LAST 30 DAYS DEV	LAST 30 MTHS MEAN	LAST 30 MTHS DEV	
HUA FER	1.2E-14	8.0E-16	-----	-----	-----	-----	-----	-----	RTE
RFRM	0.0	0.0	-----	-----	-----	-----	-----	-----	RTE
SBL FER	1.2E-14	4.0E-16	-----	-----	-----	-----	-----	-----	RTE
RFRM	0.0	0.0	-----	-----	-----	-----	-----	-----	RTE

MAS

MAINTENANCE VOLTAGES - HUA										TIME 152/0819:24	
NO.	NAME	VOLTS	C	RH	AH	CG	AL	RL	MEAN	DEV	INITIAL DATE
01	TIWBI+15	15.6	G	16.5	15.7	15.0	14.2	13.5	0.0E	0.0E	152/0812
02	TIWBI+12	12.4	G	13.2	12.6	12.0	11.4	10.8	0.0E	0.0E	152/0812
03	TI4000+5	4.96	G	5.50	5.25	5.00	4.75	4.50	0.0E	0.0E	152/0812
04	TI4000-6	-6.08	G	-5.40	-5.70	-6.00	-6.30	-6.60	0.0E	0.0E	152/0812
05	RADIO+24	23.9	G	26.4	25.2	24.0	22.8	21.6	0.0E	0.0E	152/0812
06	RADIO-20	-19.9	G	-18.0	-19.0	-20.0	-21.0	-22.0	0.0E	0.0E	152/0812

#5 1 June 77

MAS	MAINTENANCE VOLTAGES - SBL										TIME 152/0820:28
NO.	NAME	VOLTS	C	RH	AH	CG	AL	RL	MEAN	DEV	INITIAL DATE
01	TIWB1+15	15.2	G	16.5	15.7	15.0	14.2	13.5	0.0E	0.0E	000/0000
02	TIWB1+12	12.3	G	13.2	12.6	12.0	11.4	10.8	0.0E	0.0E	000/0000
03	TI4000+5	4.95	G	5.50	5.25	5.00	4.75	4.50	0.0E	0.0E	000/0000
04	TI4000-6	-5.33	G	-5.40	-5.70	-6.00	-6.30	-6.60	0.0E	0.0E	000/0000
05	RADIO+24	24.0	G	26.4	25.2	24.0	22.8	21.6	0.0E	0.0E	000/0000
06	RADIO-20	-20.1	G	-18.0	-19.0	-20.0	-21.0	-22.0	0.0E	0.0E	000/0000

-2

		LINK PERFORMANCE ASSESSMENT - RADIOS					TIME 152/0845:19		
	LAST SCAN	LAST HR MEAN	LAST 24 HR MEAN	LAST 24 HR DEV	LAST 30 DAYS MEAN	LAST 30 DAYS DEV	LAST 30 MTHS MEAN	LAST 30 MTHS DEV	
JA	RSLMAR	19.879	25.204						DB
3	EYEMAR	8.9786	9.4698						DB
	RSLAVL	1.0000	1.0000						RATE
	EYEAVL	1.0000	1.0000						RATE
	EYEHIT	0.0	0.0						/SC
JA	RSLMAR	21.746	26.346						DB
3	EYEMAR	3.4940	3.2517						DB
	RSLAVL	1.0000	1.0000						RATE
	EYEAVL	1.0000	1.0000						RATE
	EYEHIT	.14133	.07664						/SC
BL	RSLMAR	40.222	41.400						DB
3	EYEMAR	13.597	13.714						DB
	RSLAVL	1.0000	1.0000						RATE
	EYEAVL	1.0000	1.0000						RATE
	EYEHIT	0.0	.00150						/SC
BL	RSLMAR	24.583	32.224						DB
3	EYEMAR	13.943	13.890						DB
	RSLAVL	1.0000	1.0000						RATE
	EYEAVL	1.0000	1.0000						RATE
	EYEHIT	1.0969	.54844						/SC

#7 1 June 77

15

		LINK PERFORMANCE ASSESSMENT - RADIOS					TIME 152/0956:54		
	LAST SCAN	LAST HR MEAN	LAST 24 HR MEAN	LAST 24 HR DEV	LAST 30 DAYS MEAN	LAST 30 DAYS DEV	LAST 30 MTHS MEAN	LAST 30 MTHS DEV	
JA	RSLMAR	28.873	29.411	24.153	0.0				DB
	EYEMAR	15.254	13.703	9.3733	0.0				DB
	RSLAVL	1.0000	1.0000	1.0000					RATE
	EYEAVL	1.0000	1.0000	1.0000					RATE
	EYEHIT	0.0	0.0	0.0	0.0				/SC
JA	RSLMAR	30.276	30.641	25.324	0.0				DB
3	EYEMAR	9.8217	9.7950	3.3417	0.0				DB
	RSLAVL	1.0000	1.0000	1.0000					RATE
	EYEAVL	1.0000	1.0000	1.0000					RATE
	EYEHIT	0.0	.01800	.03759	0.0				/SC
BL	RSLMAR	31.455	36.394	40.144	0.0				DB
3	EYEMAR	13.369	13.187	13.714	0.0				DB
	RSLAVL	1.0000	1.0000	1.0000					RATE
	EYEAVL	1.0000	1.0000	1.0000					RATE
	EYEHIT	0.0	0.0	.00112	0.0				/SC
BL	RSLMAR	29.538	34.639	31.347	0.0				DB
3	EYEMAR	12.800	13.566	14.090	0.0				DB
	RSLAVL	1.0000	1.0000	1.0000					RATE
	EYEAVL	1.0000	1.0000	1.0000					RATE
	EYEHIT	0.0	0.0	.21938	0.0				/SC

PROCEDURE	DATE	TIME
<u>Reciprocal Path Problem</u>		
N1. Insert 10dB of attenuation between equalizer and IF in the A and B receivers at both HUA and SBL. <i>(Accomplished by inserting 10dB of attenuation in both transmit and RX H waveguides @ SBL)</i>	6-3-77	0845
<u>Transmit Antenna Only at Sibyl</u>		
N2. Insert 10dB of attenuation between equalizer and IF in the A and B receivers at HUA and the B receiver only at SBL. <i>(Accomplished by inserting 10dB of attenuation in transmit waveguide @ SBL)</i>	6-1-77	0832
N3. Restore equipment to baseline configuration	6-1-77	
	6-3-77	1015
CONDUCTED BY	<u>C. L. Christner</u> 6-3-77 16-3-77	
OBSERVED BY	_____	

DATEC SYSTEM EVALUATION WORKSHEET

OBSERVANCE (key points only)	PRINTOUT REF (ATTACH)	DATE	TIME
Awaiting test ATT..Systems clear..System data attached../////RR	1-5/3 June 77	6/3	0807
CRT showing Red on FSL margin here at HUA.. A lso showing A mber conditions on both "A" & "B" ra dios here and on "B" at SBL..//RR	6/3 June 77		0847
Now showing Amber on SEL FSL margin...//RR	7/June 77		0855
Requested maint a t SBL chker his antenna align- ment..//RR	8/3 June 77		0902
System fivers att, SEL maint corrected prob..//RR	8/3 June 77		0908
TECH CONTROLLER _____			
OBSERVED BY _____			

#1 3 June 77

MAC-1-07-12	SYSTEM OVERVIEW		TIME 154/0752:19
	HUA	SBL	
RADIO A	.	.	
B	.	.	
MUX SW	.	.	
A	.	.	
B	.	.	
CY104	.	.	
	.	.	
	.	.	
	.	.	
	.	.	
TIWBI	.	.	
	.	.	
	.	.	
TELEMETRY.	
SITE :	:	:	

AS-1	LINK STATUS				TIME 154/0753:13
TI-4000.....	RADIO.....		
	HUA	SBL	HUA	SBL	
ALARM	SW MAJOR	.	TX PROB	.	
	SW MINOR	.	RX PROB	.	
	MAJOR	.		.	
STATUS	TX IN SVC	A . A	TX IN SVC	A . A	
	RX IN SVC	A . A	RX IN SVC	A . A	
	MAINT	.	MAINT	.	
PARAMETER	FER	<1.0E-7	RX SQUELCH	.	
	CRFRM	.	RSL MARGIN	28.873 . 42.000	
	BER COR	NO DATA	EYE MARGIN	9.5055 . 12.914	
		NO DATA	EYE AMPL	-8.8065 . -8.0677	
			EYE HITS	0.0 . 0.0	
			DER BER	2.0E-11 . 3.0E-13	
				PAGE 1	

#2 3 June 77

IQ-005

LINK STATUS

TIME 154/0754:04

.....CY-104.....

.....TIWBI.....

ALARM	SERVICE	HUA	SBL	OFFICE	HUA	SBL
	REMOTE
STATUS	MAINT	.	.	MAINT	.	.
PARAMETER	CHANNEL	.	.	FER <1.0E-6	<1.0E-6	.
		.	.	REFRAME	.	.
SITE ALARMS	ENTRY	.	.			
	FIRE	.	.			
	AC PWR	.	.			
	BATTERY	.	.			
	W.A. PR	.	.			
	W.G. HV	.	.			
	FL(X)D	.	.			

PAGE 2

MAC-1-13-17

LINK PERFORMANCE ASSESSMENT - RADIOS

TIME 154/0754:56

	LAST SCAN	LAST HR MEAN	LAST 24 HR MEAN	LAST 24 HR DEV	LAST 30 DAYS MEAN	LAST 30 DAYS DEV	LAST 30 MTHS MEAN	LAST 30 MTHS DEV	
HUA RSLMAR	28.873	29.970	29.655	.90374	-----	-----	-----	-----	DB
A EYEMAR	9.5055	9.4796	9.3995	.41433	-----	-----	-----	-----	DB
RSLAVL	1.0000	1.0000	1.0000	-----	-----	-----	-----	-----	RATE
EYEA VL	1.0000	1.0000	1.0000	-----	-----	-----	-----	-----	RATE
EYEHIT	0.0	.00298	.11860	.50575	-----	-----	-----	-----	/SC
HUA RSLMAR	30.683	31.797	29.480	8.5086	-----	-----	-----	-----	DB
B EYEMAR	2.4979	2.1163	4.0945	3.4159	-----	-----	-----	-----	DB
RSLAVL	1.0000	1.0000	.96491	-----	-----	-----	-----	-----	RATE
EYEA VL	1.0000	1.0000	.99301	-----	-----	-----	-----	-----	RATE
EYEHIT	1.4667	.09493	4.2647	13.853	-----	-----	-----	-----	/SC
SBL RSLMAR	42.000	40.257	40.790	.76406	-----	-----	-----	-----	DB
A EYEMAR	12.914	12.914	12.895	.45695	-----	-----	-----	-----	DB
RSLAVL	1.0000	1.0000	1.0000	-----	-----	-----	-----	-----	RATE
EYEA VL	1.0000	1.0000	1.0000	-----	-----	-----	-----	-----	RATE
EYEHIT	0.0	0.0	.00009	.00323	-----	-----	-----	-----	/SC
SBL RSLMAR	36.667	36.500	35.763	1.0725	-----	-----	-----	-----	DB
B EYEMAR	13.482	13.170	12.905	.52788	-----	-----	-----	-----	DB
RSLAVL	1.0000	1.0000	1.0000	-----	-----	-----	-----	-----	RATE
EYEA VL	1.0000	1.0000	1.0000	-----	-----	-----	-----	-----	RATE
EYEHIT	0.0	0.0	.00721	.03257	-----	-----	-----	-----	/SC

3 3 June 77

AS-2

		LINK PERFORMANCE ASSESSMENT - RADIOS					TIME 154/0756:03		
	LAST SCAN	LAST HR MEAN	LAST 24 HR MEAN	DEV	LAST 30 DAYS MEAN	DEV	LAST 30 MTHS MEAN	DEV	
HUA EYEVOL	-4.1100	-4.1125	-4.1202	.03912	-----	-----	-----	-----	VLTS
A RXSQH	0.0	0.0	0.0	-----	-----	-----	-----	-----	RTE
HUA EYEVOL	-4.8300	-4.8733	-4.4945	1.0209	-----	-----	-----	-----	VLTS
B RXSQH	0.0	0.0	3.0000	-----	-----	-----	-----	-----	RTE
HUA LNKAVL	1.0000	1.0000	0.9964	-----	-----	-----	-----	-----	RTE
SBL EYEVOL	-3.8000	-3.8000	-3.8017	.04023	-----	-----	-----	-----	VLTS
A RXSQH	0.0	0.0	0.0	-----	-----	-----	-----	-----	RTE
SBL EYEVOL	-3.7500	-3.7775	-3.8015	.04972	-----	-----	-----	-----	VLTS
B RXSQH	0.0	0.0	0.0	-----	-----	-----	-----	-----	RTE
SBL LNKAVL	1.0000	1.0000	1.0000	-----	-----	-----	-----	-----	RTE

G0IHUA

#4 3 June 77

MAS LINK PERFORMANCE ASSESSMENT - T1-4000 TIME 154/0810:41

		LAST SCAN	LAST HR MEAN	LAST 24 HR MEAN	LAST 30 DAYS DEV	LAST 30 MTHS MEAN	LAST 30 MTHS DEV	
HUA	FER	1.0E-15	3.3E-16	3.9E-16	-----	-----	-----	RTE
A	FERAVL	1.0000	1.0000	1.0000	-----	-----	-----	RTE
	CRFRM	0.0	0.0	2.0000	-----	-----	-----	RTE
	CR/SQH	0.0	0.0	0.0	-----	-----	-----	RTE
	CR/HIT	0.0	0.0	0.0	-----	-----	-----	RTE
HUA	FER	1.0E-15	3.3E-17	-----	-----	-----	-----	RTE
B	FERAVL	1.0000	1.0000	1.0000	-----	-----	-----	RTE
	CRFRM	0.0	1.0000	3.0000	-----	-----	-----	RTE
	CR/SQH	0.0	0.0	0.0	-----	-----	-----	RTE
	CR/HIT	0.0	0.0	0.0	-----	-----	-----	RTE
SBL	FER	1.0E-15	3.0E-16	1.5E-8	-----	-----	-----	RTE
A	FERAVL	1.0000	1.0000	1.0000	-----	-----	-----	RTE
	CRFRM	0.0	0.0	1.0000	-----	-----	-----	RTE
	CR/SQH	0.0	0.0	0.0	-----	-----	-----	RTE
	CR/HIT	0.0	0.0	0.0	-----	-----	-----	RTE
SBL	FER	5.2E-10	1.7E-11	3.9E-6	-----	-----	-----	RTE
B	FERAVL	1.0000	1.0000	1.0000	-----	-----	-----	RTE
	CRFRM	0.0	0.0	1.0000	-----	-----	-----	RTE
	CR/SQH	0.0	0.0	0.0	-----	-----	-----	RTE
	CR/HIT	0.0	0.0	0.0	-----	-----	-----	RTE

TQ-008 LINK PERFORMANCE ASSESSMENT - TIWBI TIME 154/0801:36

		LAST SCAN	LAST HR MEAN	LAST 24 HR MEAN	LAST 30 DAYS DEV	LAST 30 MTHS MEAN	LAST 30 MTHS DEV	
HUA	FER	1.2E-14	4.0E-15	3.0E-9	-----	-----	-----	RTE
	RFRM	0.0	1.0000	1.000	-----	-----	-----	RTE
SBL	FER	1.2E-14	4.0E-15	4.7E-15	-----	-----	-----	RTE
	RFRM	0.0	0.0	1.0000	-----	-----	-----	RTE

#5 3 June 77

MAC -13-17

MAINTENANCE VOLTAGES - S2L

TIME 154/0002:21

NO.	NAME	VOLTS	C	RH	AH	CG	AL	RL	MEAN	DEV	INITIAL	DATE
01	TIWB1+15	15.1	G	16.5	15.7	15.0	14.2	13.5	15.1	.020		153/0911
02	TIWB1+12	12.3	G	13.2	12.6	12.0	11.4	10.8	12.3	.007		153/0911
03	T14000+5	4.95	G	5.50	5.25	5.00	4.75	4.50	4.95	0		153/0911
04	T14000-6	-6.05	G	-5.40	-5.70	-6.00	-6.30	-6.60	-6.04	.004		153/0911
05	RADIO+24	24.1	G	26.4	25.2	24.0	22.8	21.5	24.1	.010		153/0911
06	RADIO-20	-20.1	G	-18.0	-19.0	-20.0	-21.0	-22.0	-20.1	1.6E		153/0911

MAC-3-18-23

MAINTENANCE VOLTAGES - HUA

TIME 154/0003:18

NO	NAME	VOLTS	C	RH	AH	CG	AL	RL	MEAN	DEV	INITIAL	DATE
01	TIWB1+15	15.6	G	16.5	15.7	15.0	14.2	13.5	15.5	.046		153/0907
02	TIWB1+12	12.4	G	13.2	12.6	12.0	11.4	10.8	12.4	.017		153/0907
03	T14000+5	4.96	G	5.50	5.25	5.00	4.75	4.50	4.95	.006		153/0907
04	T14000-6	-6.08	G	-5.40	-5.70	-6.00	-6.30	-6.60	-6.08	0		153/0907
05	RADIO+24	24.0	G	26.4	25.2	24.0	22.8	21.6	23.9	.026		153/0907
06	RADIO-20	-19.9	G	-18.0	-19.0	-20.0	-21.0	-22.0	-19.9	.009		153/0907

LINK STATUS
T1-4000.....
 HUA SBL

TIME 154/0347:49
RADIO.....
 HUA SBL

	SW MAJOR	.	.	TX PROB	.
ALARM	SW MINOR	.	.	RX PROB	.
	MAJOR	.	.		.
STATUS	TX IN SVC	A	A	TX IN SVC	A . A
	RX IN SVC	A	A	RX IN SVC	A . A
	MAINT	.	.		.
PARAMETER	FER	<1.0E-7	<1.0E-7	RX SQUELCH	.
	CRFRM	.	.	RSL MARGIN	16.540 . 32.071
				EYE MARGIN	9.6393 . 12.459
	BER COR	NO DATA	NO DATA	EYE AMPL	-8.8365 . -8.2677
				EYE HITS	0.0 . 0.0
				DER BER	1.7E-11 . 5.5E-13

PAGE 1

6
3 June 27

IQ-008

SYSTEM OVERVIEW

TIME 154/0349:00

	HUA	SBL
RADIO A	.AI<	.
RADIO B	.AS<	>SA.
MUX SW	.	.
A	.	.
B	.	.
CY104	.	.
.	.	.
.	.	.
.	.	.
.	.	.
.	.	.
.	.	.
.	.	.
.	.	.
.	.	.
TIWB1	.	.
.	.	.
.	.	.
TELEMETRY.	.	.
.	.	.
SITE	.	.

MAC-3-18-23

MAINTENANCE VOLTAGES - SBL

TIME 154/0303:37
 INITIAL

NO.	NAME	VOLTS	C	RH	AH	CG	AL	RL	MEAN	DEV	DATE
31	TIWB1+15	15.2	G	16.5	15.7	15.0	14.2	13.5	15.1	.019	153/0911
32	TIWB1+12	12.3	G	13.2	12.6	12.0	11.4	10.8	12.3	.037	153/0911
33	T14000+5	4.95	G	5.50	5.25	5.00	4.75	4.50	4.95	.010	153/0911
34	T14000-6	-6.04	G	-5.40	-5.70	-6.00	-6.30	-6.60	-6.04	.004	153/0911
35	RADIO+24	24.1	G	26.4	25.2	24.3	22.8	21.6	24.1	.010	153/0911
36	RADIO-27	-20.1	G	-18.0	-19.0	-20.3	-21.0	-22.0	-20.1	.010	153/0911

MAC-3-07-12

LINK STATUS
.....TI-4000.....
HUA SBL

#7
3 June 77

TIME 154/0855:49
.....RADIO.....
HUA SBL

ALARM	SW MAJOR	.	.						
	SW MINOR	.	.						
	MAJOR	.	.						
STATUS	TX IN SVC	A	.	A	TX IN SVC	A	.	A	
	RX IN SVC	A	.	A	RX IN SVC	A	.	A	
	MAINT	.	.		MAINT	.	.		
PARAMETER	FER	<1.0E-7	.	<1.0E-7	RX SQUELCH	.	.		
	CRFRM	.	.		RSL MARGIN	16.944	R.	30.182	A
	BER COR	NO DATA	.	NO DATA	EYE MARGIN	9.6090	.	12.459	
					EYE AMPL	-8.8065	.	-8.9677	
					EYE HITS	0.0	.	0.0	
					DER BER	1.7E-11	.	5.5E-13	

PAGE 1

AS-2

LINK PERFORMANCE ASSESSMENT - RADIOS

TIME 154/0857:21

		LAST SCAN	LAST HR MEAN	LAST 24 HR MEAN	LAST 24 HR DEV	LAST 30 DAYS MEAN	LAST 30 DAYS DEV	LAST 30 MTHS MEAN	LAST 30 MTHS DEV	
HUA	RSLMAR	16.944	26.490	20.669	.88694	-----	-----	-----	-----	DB
A	EYEMAR	9.6090	9.3738	9.4032	.40560	-----	-----	-----	-----	DB
	RSLAVL	1.0000	1.0000	1.0000	-----	-----	-----	-----	-----	RATE
	EYEA VL	1.0000	1.0000	1.0000	-----	-----	-----	-----	-----	RATE
	EYEHIT	0.0	0.0	.11355	.49520	-----	-----	-----	-----	/SC
HUA	RSLMAR	19.355	28.422	29.577	8.3423	-----	-----	-----	-----	DB
B	EYEMAR	1.8693	3.3048	4.0121	3.3673	-----	-----	-----	-----	DB
	RSLAVL	1.0000	1.0000	.96622	-----	-----	-----	-----	-----	RATE
	EYEA VL	1.0000	1.0000	0.9932	-----	-----	-----	-----	-----	RATE
	EYEHIT	.14400	.08640	4.0908	13.586	-----	-----	-----	-----	/SC
SBL	RSLMAR	30.182	39.868	40.778	.75007	-----	-----	-----	-----	DB
A	EYEMAR	12.459	12.545	12.896	.44646	-----	-----	-----	-----	DB
	RSLAVL	1.0000	1.0000	1.0000	-----	-----	-----	-----	-----	RATE
	EYEA VL	1.0000	1.0000	1.0000	-----	-----	-----	-----	-----	RATE
	EYEHIT	0.0	0.0	.00095	.00374	-----	-----	-----	-----	/SC
SBL	RSLMAR	24.417	32.474	35.794	1.0606	-----	-----	-----	-----	DB
B	EYEMAR	13.255	13.210	12.917	.51850	-----	-----	-----	-----	DB
	RSLAVL	1.0000	1.0000	1.0000	-----	-----	-----	-----	-----	RATE
	EYEA VL	1.0000	1.0000	1.0000	-----	-----	-----	-----	-----	RATE
	EYEHIT	0.0	0.0	.00690	.03188	-----	-----	-----	-----	/SC
K11		1.0000	1.0000	.96622	-----	-----	-----	-----	-----	

#8
3 June 77

IQ-008

		LINK STATUS T1-4000		TIME 154/0900:21 RADIO	
		HUA	SBL	HUA	SBL
ARM	SW MAJOR
	SW MINOR
	MAJOR
STATUS	TX IN SVC	A	A	A	A
	RX IN SVC	A	A	A	A
	MAINT
PARAMETER	FER	<1.0E-7	<1.0E-7	.	.
	CRFRM
	BER COR	NO DATA	NO DATA	19.369 A	30.182 A
				9.6090	12.459
				-8.8065	-8.9677
				0.0	0.0
				1.7E-11	5.5E-13

MAS

		LINK STATUS T1-4000		TIME 154/0906:15 RADIO	
		HUA	SBL	HUA	SBL
ALARM	SW MAJOR
	SW MINOR
	MAJOR
STATUS	TX IN SVC	A	A	A	A
	RX IN SVC	A	A	A	B
	MAINT
PARAMETER	FER	<1.0E-7	<1.0E-7	.	.
	CRFRM
	BER COR	NO DATA	NO DATA	29.423	35.500
				9.7148	13.028
				-8.8065	-8.9677
				0.0	0.0
				1.5E-11	5.5E-13

IQ-008

		LINK STATUS T1-4000		TIME 154/0908:44 RADIO	
		HUA	SBL	HUA	SBL
ALARM	SW MAJOR
	SW MINOR
	MAJOR
STATUS	TX IN SVC	A	A	A	A
	RX IN SVC	A	A	A	A
	MAINT
PARAMETER	FER	<1.0E-7	<1.0E-7	.	.
	CRFRM
	BER COR	NO DATA	NO DATA	29.423	30.500
				9.7148	12.800
				-8.8065	-8.9677
				0.0	0.0
				1.5E-11	3.5E-13

PROCEDURE	DATE	TIME
U1. Install the Frame Bit Error Generator (FBEG) between the radio and TI-4000 in the RX base-band input line at SBL.	6/10/77	
U2. With the selector switch of the FBEG set to NARROW, momentarily depress the pushbutton switch several times (3-5). Repeat this operation at a rate of approximately once every 5 minutes. Record the time when each operation is performed.		0800
Perturbation No. 1		0800
" " 2		0804
" " 3		0808
" " 4		0812
" " 5		0816
" " 6		0820
" " 7		0824
" " 8		
" " 9		
" " 10		
COMPLETE		0850
U3. When test is completed, restore equipment to baseline configuration.		
CONDUCTED BY <i>T. Campbell</i> 6/10/77		
OBSERVED BY _____		

DATEC SYSTEM EVALUATION WORKSHEET

Page 1

OBSERVANCE (key points only)	PRINCIPAL REF (ATTACH)	DATE	TIME
All systems clear...Base Line data...//cs	1-4/ 10June 77	10/6 6/10	0750
CRT systems Overview indicates a problem with SBL's TL-4000 mux..bad FER...//dg	5/10June 77 6/10 June		0807
Check ra dio RSL's, Maint voltages a ppeared OK. Request Maint switch TL-4000 recv "A" to recv "B".			082 0
System is good with the "B" mux recv ...asked maint to check SBL's tl-4000 "A " recv...//dg		6/10	0830
Maint advised there was a bad "A" recv card in the TL-4000 at SBL. Switched"A" recv back on line. System clear....//dg		6/10	0840
<hr/> Problem isolated to bad recv card in TL-4000 at SBL.			
There wa s a distinnt disadvantage in not being able to have both FER's of both recvs of the TL-4000 while in monitor immediate. Only the recv mux on line wa s updated.cs			
NOTE: ther were erroneous FF FER displays for the XX "B" mux, problem turned over to the soft ware personel..cs		6/10	0845
The problem with the erroneous FER displays on the "B" mux at SBL appears/appeared to be within the DATEC equipment...However, this clea red up before it could be isolated...The monitoring system now appears to be functioning properly..Will continue to monitor this to see if it appears again...//RR			
TECH CONTROLLER	<u>DBL</u>		
OBSERVED BY	<u>CHS</u>		

1 10 June 77

MAC-3-07-12

SYSTEM OVERVIEW

TIME 16170734:49

	HUA	SBL
RADIO A	.	.
B	.	.
MUX SW	.	.
A	.	.
B	.	.
CY104	.	.
	.	.
	.	.
	.	.
	.	.
	.	.
T1WB1	.	.
	.	.
	.	.
TELEMETRY.
SITE	.	.

AS-2

LINK STATUS

TIME 16170734:55

.....T1-4000.....

.....RADIO.....

		HUA	SBL		HUA	SBL
ALARM	SW MAJOR		.	TX PROB		.
	SW MINOR		.	RX PROB		.
	MAJOR		.			.
STATUS	TX IN SVC	A	A	TX IN SVC	A	A
	RX IN SVC	A	A	RX IN SVC	A	A
	MAINT		.			.
PARAMETER	FER	<1.0E-7	<1.0E-7	RX SQUELCH		.
	CRFM		.	RSL MARGIN	34.332	37.533
	RER COR	NO DATA	NO DATA	EYE MARGIN	13.432	14.304
				EYE AMPL	-8.8065	-9.0000
				EYE HITS	0.0	0.0
				DR BER	1.4E-13	4.3E-14

270

PAGE 1

BEST AVAILABLE COPY

BEST AVAILABLE COPY

#2 10 June 77

10-305		LINK STATUS		TIME 16170739:48	
	CY-104.....	TIME.....	
		HUA	SBL	HUA	SBL
ALARM	SERVICE
	REMOTE
STATUS	MAINT
PARAMETER	CHANNEL	.	.	PER <1.0E-6	<1.0E-6
		.	.	REFRA 4E	.
SITE ALARMS	ENTRY	.	.		
	FIRE	.	.		
	AC PAR	.	.		
	BATTERY	.	.		
	N.A. PR	.	.		
	N.G. HV	.	.		
	FLOOD	.	.		

PAGE 2

MAC-1-01-06		LINK PERFORMANCE ASSESSMENT - RADIOS						TIME 16170739:59	
		LAST SCAN	LAST HR	LAST 24 HR	LAST 30 DAYS	LAST 30 DAYS	LAST 30 MTHS	LAST 30 MTHS	
			MEAN	MEAN	DEV	MEAN	DEV	MEAN	DEV
HUA	RSLMAR	30.333	29.879	29.972	.48665	25.589	8.4563	-----	DB
A	EYEMAR	13.482	13.715	13.443	.22197	9.4929	4.9902	-----	DB
	RSLAVL	1.0000	1.0000	1.0000	-----	.37494	-----	-----	RATE
	EYEA VL	1.0000	1.0000	1.0000	-----	.87130	-----	-----	RATE
	EYEHIT	0.0	0.0	0.0	0.0	31.435	60.488	-----	ZSC
HUA	RSLMAR	27.516	27.306	27.285	1.3210	30.241	2.0940	-----	DB
B	EYEMAR	5.8569	6.2250	6.3604	.75243	6.4459	2.5487	-----	DB
	RSLAVL	1.0000	1.0000	1.0000	-----	.98842	-----	-----	RATE
	EYEA VL	1.0000	1.0000	1.0000	-----	3.9983	-----	-----	RATE
	EYEHIT	0.0	0.0	.61455	2.1336	3.7895	4.5883	-----	ZSC
SBL	RSLMAR	37.500	37.643	36.269	2.4525	39.053	1.0347	-----	DB
A	EYEMAR	14.300	14.065	13.581	.45742	12.913	.60520	-----	DB
	RSLAVL	1.0000	1.0000	1.0000	-----	1.0000	-----	-----	RATE
	EYEA VL	1.0000	1.0000	1.0000	-----	4.9266	-----	-----	RATE
	EYEHIT	0.0	0.0	.00066	.00211	2.8971	3.7059	-----	ZSC
SBL	RSLMAR	32.333	32.483	32.220	1.2777	34.472	.93899	-----	DB
B	EYEMAR	13.831	13.831	13.460	.49666	12.544	1.4944	-----	DB
	RSLAVL	1.0000	1.0000	1.0000	-----	1.0000	-----	-----	RATE
	EYEA VL	1.0000	1.0000	1.0000	-----	0.0966	-----	-----	RATE
	EYEHIT	0.0	0.0	.00028	.00099	1.4062	3.1386	-----	ZSC
PI		1.0000	1.0000	1.0000	-----	1.0000	-----	-----	011 1.0000 1

#3 10 June 77

	LAST SCAN	LAST HR MEAN	LAST 24 HR MEAN	DEV	LAST 30 DAYS MEAN	DEV	LAST 30 MTHS MEAN	DEV	
HUA EYEVOL	-3.7500	-3.7300	-3.7398	.07930	-4.1448	.41597	-----	-----	VLFS
A RXSQH	0.0	0.0	0.0	-----	6.0000	-----	-----	-----	RTE
HUA EYEVOL	-4.4700	-4.4325	-4.4147	.09514	-4.3948	.23963	-----	-----	VLFS
B RXSQH	0.0	0.0	0.0	-----	12.000	-----	-----	-----	RTE
HUA LNKAVL	1.0000	1.0000	0.9964	-----	0.9992	-----	-----	-----	RTE
SBL EYEVOL	-3.6800	-3.7000	-3.6657	.37496	-3.7942	.06527	-----	-----	VLFS
A RXSQH	0.0	0.0	0.0	-----	13.000	-----	-----	-----	RTE
SBL EYEVOL	-3.7200	-3.7200	-3.7345	.10055	-3.8310	.14175	-----	-----	VLFS
B RXSQH	0.0	0.0	0.0	-----	3.0000	-----	-----	-----	RTE
SBL LNKAVL	1.0000	1.0000	1.0000	-----	1.0000	-----	-----	-----	RTE
N11	0.0	0.0	0.0	-----	13.000	-----	-----	-----	P01SBLP11-3.7

	LAST SCAN	LAST HR MEAN	LAST 24 HR MEAN	DEV	LAST 30 DAYS MEAN	DEV	LAST 30 MTHS MEAN	DEV	
HUA FER	1.0E-15	2.3E-16	2.4E-16	-----	5.5E-8	-----	-----	-----	RTE
A FERAVL	1.0000	1.0000	1.0000	-----	1.0000	-----	-----	-----	RTE
CRFRM	0.0	0.0	0.0	-----	3.3333	2.6874	-----	-----	RTE
CR/SQH	0.0	0.0	0.0	-----	1.0000	-----	-----	-----	RTE
CR/HIT	0.0	0.0	0.0	-----	2.0000	-----	-----	-----	RTE
HUA FER	1.0E-15	3.3E-17	1.4E-18	-----	1.4E-12	-----	-----	-----	RTE
B FERAVL	1.0000	1.0000	1.0000	-----	1.0000	-----	-----	-----	RTE
CRFRM	0.0	0.0	1.0000	-----	2.3333	2.6487	-----	-----	RTE
CR/SQH	0.0	0.0	0.0	-----	1.0000	-----	-----	-----	RTE
CR/HIT	0.0	0.0	0.0	-----	1.0000	-----	-----	-----	RTE
SBL FER	1.0E-15	2.3E-16	7.9E-6	-----	4.0E-7	-----	-----	-----	RTE
A FERAVL	1.0000	1.0000	1.0000	-----	1.0000	-----	-----	-----	RTE
CRFRM	0.0	0.0	1.0000	-----	1.6667	2.2111	-----	-----	RTE
CR/SQH	0.0	0.0	0.0	-----	4.0000	-----	-----	-----	RTE
CR/HIT	0.0	0.0	0.0	-----	5.0000	-----	-----	-----	RTE
SBL FER	5.2E-10	6.0E-9	-----	-----	1.3E-7	-----	-----	-----	RTE
B FERAVL	1.0000	1.0000	-----	-----	1.0000	-----	-----	-----	RTE
CRFRM	0.0	0.0	1.0000	-----	1.6667	1.4625	-----	-----	RTE
CR/SQH	0.0	0.0	0.0	-----	3.0000	-----	-----	-----	RTE
CR/HIT	0.0	0.0	0.0	-----	3.0000	-----	-----	-----	RTE

#4 10 June 77

MAC-1-07-12 LINK PERFORMANCE ASSESSMENT - TIWB1 TIME 161/0744:11

		LAST SCAN	LAST HR MEAN	LAST 24 HR MEAN	LAST 24 HR DEV	LAST 30 DAYS MEAN	LAST 30 DAYS DEV	LAST 30 MTHS MEAN	LAST 30 MTHS DEV	
HUA FER		1.2E-14	3.2E-15	.00014	-----	1.4E-7	-----	-----	-----	RTE
RFRM		0.0	0.0	3.0000	-----	5.8333	4.1399	-----	-----	RTE
SBL FER		1.2E-14	2.8E-15	.00019	-----	3.2E-6	-----	-----	-----	RTE
RFRM		0.0	0.0	1.0000	-----	3.3333	2.8674	-----	-----	RTE

A5-1 MAINTENANCE VOLTAGES - HUA TIME 161/0745:03

NO.	NAME	VOLTS	C	RH	AH	CG	AL	RL	MEAN	DEV	INITIAL DATE
01	TIWB1+15	15.5	G	16.5	15.7	15.0	14.2	13.5	14.9	3.09	153/0907
02	TIWB1+12	12.4	G	13.2	12.6	12.0	11.4	10.8	11.9	2.46	153/0907
03	T14000+5	4.96	G	5.50	5.25	5.00	4.75	4.50	4.95	.008	153/0907
04	T14000-6	-6.08	G	-5.40	-5.70	-6.00	-6.30	-6.60	-6.08	3	153/0907
05	RADIO+24	24.0	G	26.4	25.2	24.0	22.8	21.6	23.9	.029	153/0907
06	RADIO-20	-19.9	G	-18.0	-19.0	-20.0	-21.0	-22.0	-19.9	.006	153/0907

A52 @49HUAD0101D05TIWB1+15 D16 15.5D

2
46028 16.5 15.7 15.0 14.2 13

NO.	NAME	VOLTS	C	RH	AH	CG	AL	RL	MEAN	DEV	INITIAL DATE
01	TIWB1+15	15.2	G	16.5	15.7	15.0	14.2	13.5	15.2	.013	153/0911
02	TIWB1+12	12.3	G	13.2	12.6	12.0	11.4	10.8	12.3	.011	153/0911
03	T14000+5	4.95	G	5.50	5.25	5.00	4.75	4.50	4.95	.009	153/0911
04	T14000-6	-6.04	G	-5.40	-5.70	-6.00	-6.30	-6.60	-6.03	.005	153/0911
05	RADIO+24	24.1	G	26.4	25.2	24.0	22.8	21.6	24.1	.005	153/0911
06	RADIO-20	-20.1	G	-18.0	-19.0	-20.0	-21.0	-22.0	-20.1	0	153/0911

5/10 JUNE 77

```

AS-1
RADIO A      HUA      SBL      SYSTEM OVERVIEW      TIME 16170347:38
  B          .          .
MUX SW A      .          .
  A          .          >IA.
  B          .          .
CY104        .          .
              .          .
              .          .
              .          .
              .          .
              .          .
              .          .
TIWB1        .          .
              .          .
              .          .
TELEMETRY. . . . .
SITE         .          .
    
```

```

MAC-1-07-12          LINK STATUS          TIME 16170314:34
                       . . . . . TI-4000 . . . . .          . . . . . RADIO . . . . .
                       HUA      SBL          HUA      SBL
ALARM    SW MAJOR      .          .          TX PROB
          SW MINOR     .          .          RX PROB
          MAJOR        .          .
STATUS   TX IN SVC     A      .      A      TX IN SVC     A      .      A
          RX IN SVC     A      .      A      RX IN SVC     A      .      A
          MAINT         .          .
PARAMETER FER          <1.0E-7 . 1.0E-5 A  RX SQUELCH     .          *
          CRFRM        .          .          RSL MARGIN     29.936 . 40.556
          BER COR      NO DATA . 6.950/ R  EYE MARGIN     13.331 . 13.527
          .          .          EYE AMPL       -3.8365 . -9.0000
          .          .          EYE HITS       1.0 . 1.1
          .          .          DER BER        8.4E-14 . 1.2E-13
          .          .          PAGE 1
    
```

6/10 JUNE 79

D01HUAD?y0-008

		LINK PERFORMANCE ASSESSMENT - RADIOS							TIME	161
		LAST SCAN	LAST HR MEAN	LAST 24 HR MEAN	LAST 24 HR DEV	LAST 30 DAYS MEAN	LAST 30 DAYS DEV	LAST 30 MTHS MEAN	LAST 30 MTHS DEV	
HUA	EYEVOL	-3.7300	-3.7300	-3.7381	.07886	-4.1448	.41897	-----	-----	VLTS
A	RXSQH	0.0	0.0	0.0	-----	6.0000	-----	-----	-----	RTE
HUA	EYEVOL	-4.4700	-4.4700	-4.4129	.09423	-4.3948	.23963	-----	-----	VLTS
B	RXSQH	0.0	0.0	0.0	-----	12.000	-----	-----	-----	RTE
HUA	LNKAVL	1.0000	1.0000	0.9965	-----	0.9992	-----	-----	-----	RTE
SBL	EYEVOL	-3.7400	-3.7400	-3.6649	.37485	-3.7942	.06527	-----	-----	VLTS
A	RXSQH	0.0	0.0	1.0000	-----	13.000	-----	-----	-----	RTE
SBL	EYEVOL	-3.7700	-3.7700	-3.7329	.10036	-3.8310	.14178	-----	-----	VLTS
B	RXSQH	0.0	1.0000	0.0	-----	8.0000	-----	-----	-----	RTE
SBL	LNKAVL	1.0000	1.0000	1.0000	-----	1.0000	-----	-----	-----	RTE

MAC-3-16-17

		LINK PERFORMANCE ASSESSMENT - T1-4000							TIME	161/0837:32
		LAST SCAN	LAST HR MEAN	LAST 24 HR MEAN	LAST 24 HR DEV	LAST 30 DAYS MEAN	LAST 30 DAYS DEV	LAST 30 MTHS MEAN	LAST 30 MTHS DEV	
HUA	FER	1.0E-15	6.7E-17	2.4E-10	-----	5.5E-8	-----	-----	-----	RTE
A	FERAVL	1.0000	1.0000	1.0000	-----	1.0000	-----	-----	-----	RTE
	CRFRM	0.0	0.0	0.0	-----	3.3333	2.6874	-----	-----	RTE
	CR/SQH	0.0	0.0	0.0	-----	1.0000	-----	-----	-----	RTE
	CR/HIT	0.0	0.0	0.0	-----	9.0000	-----	-----	-----	RTE
HUA	FER	1.0E-15	3.3E-17	1.4E-18	-----	1.4E-19	-----	-----	-----	RTE
B	FERAVL	1.0000	1.0000	1.0000	-----	1.0000	-----	-----	-----	RTE
	CRFRM	0.0	0.0	1.0000	-----	2.8333	2.6087	-----	-----	RTE
	CR/SQH	0.0	0.0	0.0	-----	1.0000	-----	-----	-----	RTE
	CR/HIT	0.0	0.0	0.0	-----	1.0000	-----	-----	-----	RTE
SBL	FER	2.2E-6	7.3E-8	3.9E-6	-----	4.0E-7	-----	-----	-----	RTE
A	FERAVL	1.0000	1.0000	1.0000	-----	1.0000	-----	-----	-----	RTE
	CRFRM	0.0	0.0	1.0000	-----	1.6667	2.2111	-----	-----	RTE
	CR/SQH	0.0	0.0	0.0	-----	4.0000	-----	-----	-----	RTE
	CR/HIT	0.0	0.0	0.0	-----	5.0000	-----	-----	-----	RTE
SBL	FER	5.2E-10	6.0E-9	-----	-----	1.3E-7	-----	-----	-----	RTE
B	FERAVL	1.0000	1.0000	-----	-----	1.0000	-----	-----	-----	RTE
	CRFRM	0.0	0.0	1.0000	-----	1.1667	1.4625	-----	-----	RTE
	CR/SQH	0.0	0.0	0.0	-----	3.0000	-----	-----	-----	RTE
	CR/HIT	0.0	0.0	0.0	-----	3.0000	-----	-----	-----	RTE

During the scenarios a few omissions were noted of certain alarms/parameters which would have made the monitoring facility more complete or effective; these will be discussed. Also, in discussions with tech controllers during and following the scenario test phase, they expressed preferences regarding the parameters available for monitoring. Their remarks provided first hand user information giving insight into the completeness of the alarm/parameter list.

One of the Tech Controller comments arising from the System Simulation Scenarios dealt with the inclusion of local and remote alarm information in the CRT displays. This feature is presently included in the CY-104 alarms, i.e., Service and Remote. However, because of the way these two alarms are brought out of the CY-104, the effectiveness is negated. Both Service and Remote alarms originate via the operation of one relay, K1, within the Power and Alarm Unit of the CY-104. Therefore, if a local Service alarm has been generated, a Remote alarm is generated also. An outgoing alarm is transmitted to the far-end and results in a Service alarm at that site, and therefore, also a Remote alarm for the reason just given. The result, then, is that a local alarm at Ft. Huachuca, for example, will cause not only a Remote alarm at Site Sibyl, but a Service alarm at Sibyl and a Remote alarm at Ft. Huachuca as well. This shortcoming stems from the fact that the signal that drives the Remote Alarm Indicator on the Power and Alarm Unit of the CY-104 is inaccessible for DATEC monitoring because of TEMPEST restrictions. This aspect was discussed during the study phase for ATEC Digital Adaptation (Refer to Volume I of Final Report for ATEC Digital Adaptation Study - Report No. 476-13656).

For the Ft. Huachuca demonstration, only 6 maintenance voltages at each site were selected: two voltages from the "A" radio transceiver, two from the "A" T1-4000 multiplexer and two from the T1WB1. To provide complete monitoring, all secondary derived voltages should be monitored along with the prime dc voltage (-48V) to the communication system.

Present DATEC configuration provides for 7 site alarms:

- Entry
- Fire
- AC Power
- Battery
- Waveguide Pressure
- Waveguide Humidity
- Flood

Since no sensors/transducers were available either at Ft. Huachuca or Site Sibyl, a switch was provided to simulate one of the site alarms-- again, just for demonstration purposes. These alarms can provide very useful information. Had there been sensors for two particular functions during field tests, they would have served to prevent undesirable situations and in one instance would

have called attention to an overheating condition, in the AN/FRC-162 Radio, which eventually led to burn-out and catastrophic damage to a power supply unit. The other alarm which would have been useful was the AC Power monitor. There were numerous momentary outages of primary ac power at both Ft. Huachuca and at Site Sibyl. Power supply circuits in the AN/FRC-162 Radio were such that secondary dc supplies did not fully recover following resumption of normal line voltage levels. They remained at about half their normal voltages, causing continued loss of service. Site alarms, then, are definitely needed. A survey of a particular site should be made, and once the elements to be monitored are chosen, the only remaining task is one of providing the necessary sensors and interface with DATEC equipment.

Another parameter should be considered for Trend Analysis (TA). There is presently no CY-104 alarm/parameter monitored and trended on a long-term basis which provides information relative to service history. The CY-104 Service Alarm could be used for this purpose in much the same manner as FER is used in the FER Available TA parameter. This would involve only software changes to incorporate.

The Tech Controllers were in general agreement that one parameter, BER Correlation, which is the difference between the log of T1-4000 FER and the log of BER derived from the baseband Eye by the BEM, provided no additional information which would be useful in fault recognition or isolation. They felt that FER and the Eye parameters such as Eye Margin, Derived BER and Hits, were sufficient relative to alarming and trending.

6.1.2 The Pate Software Adaptation Requirements Specified In Paragraphs 1.3 through 1.3.1.4 of Annex II of the S.O.W.

The following matrix in Table 6-3 shows each S.O.W. section number and description followed by the PATE files or new software modules that satisfies the requirement. Also shown is a description of the way that the test data validates the requirement. The appendices under Validation refer to appendices in the Field Test Plan and Procedures document, dated 24 March 1977. Module names and their place in the software hierarchy can be obtained from Figures 6-11 through 6-15 in Paragraph 6.2.1.

6.1.3 The Hardware Adaptation Requirements Specified in Paragraphs 1.2 through 1.2.2.9 of Annex II of the S.O.W.

Compliance with each of these requirements was verified during in-plant tests of the DATEC equipment. Although not specifically addressed in the Field Test Plan/Procedures, compliance with the above paragraphs of the S.O.W. is implicit in the usage and proper operation of the hardware adaptations throughout all phases of the field test program. The field tests, specifically the System Simulation Scenarios, provided assessment of the operational

TABLE 6-3. DATEC SOFTWARE S.O.W. COMPLIANCE MATRIX

<u>S.O.W. Section No.</u>	<u>Description</u>	<u>Satisfied by Module(s)</u>	<u>Validation</u>
1.3.1.1	Addition to PATE operator interaction	PATE File \$SPCS	Presence of test data in Section II
1.3.1.2	Modify PATE DLC routines for MAC/MAD communication	PATE File \$SPNIS replaced by file \$SDL	Presence of test data in Section II
1.3.1.3	Addition of Nodal Control Monitoring task	1.0 - Task Name - NS	Presence of test data in Section II
1.3.1.3.1	Command Selection	1.1, 1.1.1 PATE IQCS Task	Observation of Scan Sequence during testing
1.3.1.3.2	Command Transmission and Reception	1.2.1, 1.3.1, 1.4.1, 1.4.2, 1.4.3, 4.11, 4.16	Presence of test data in Section II
1.3.1.3.3	Response Error checking	1.4.6, 4.9, 4.11	In-Plant Test H Field Test observation
1.3.1.3.4	Results Processing	1.4, 1.4.5, 1.5	See detail below
1.3.1.3.4 (a)	Process Major Alarm Scan Data	1.2	Validation Test Appendix A
1.3.1.3.4 (b)	Transfer and Alarm Summary Data to Site Data Base	1.3	Validation Test Appendix A
1.3.1.3.4 (c)	Calculate Site Parameters	1.5	See below
1.3.1.3.4 (c1)	RSL and RSL Availability	1.5.1	Validation Test Appendix B
1.3.1.3.4 (c2)	T1-4000 Frame Errors	1.5.9	Validation Test Appendix E
1.3.1.3.4 (c3)	T1-4000 Reframes	1.5.8	Validation Test Appendix E
1.3.1.3.4 (c4)	Eye Noise, Eye Amplitude, Eye Hits	1.5.2, 1.5.3, 1.5.4	Validation Test Appendix F

TABLE 6-3. DATEC SOFTWARE S.O.W. COMPLIANCE MATRIX (Cont)

<u>S.O.W. Section No.</u>	<u>Description</u>	<u>Satisfied by Module(s)</u>	<u>Validation</u>
1.3.1.3.4 (c5)	TlWBl Frame Errors	1.5.6	Validation Test Appendix D
1.3.1.3.4 (c6)	TlWBl Reframes	1.5.5	Validation Test Appendix D
1.3.1.3.4 (c7)	RSL/Noise Changed Link Availability	1.5.11	Validation Test Appendix G
1.3.1.3.4 (c8)	Reframes/Receiver to Squelch	1.5.7, 1.5.8	Validation Test Appendix G
1.3.1.3.4 (c9)	Reframes/Eye Hits	1.5.8	Validation Test Appendix G
1.3.1.3.4 (c10)	Error Rate Availability	1.5.9	Validation Test Appendix E
1.3.1.3.4 (c11)	Derived BER	1.5.2	Validation Test Appendix F
1.3.1.3.4 (d)	Determine BER	4.8, 4.8.1	Validation Tests B,C,D,E,F,G
1.3.1.3.4 (e)	Determine Parameter Statistics	4.8, 4.8.2, 4.8.3, 4.8.4, 4.8.5, 4.8.6, 4.8.7, 4.8.8, 4.8.9, 4.8.10	In-Plant Tests B,D,E,F,G Validation Tests B and D
1.3.1.3.5	Output Processing	1.6	See below
1.3.1.3.5 (a)	System Overview	1.6.1, 1.6.6	Validation Tests
1.3.1.3.5 (b)	Link Status - Page 1	1.6.2, 1.6.6	Validation Tests
1.3.1.3.5 (c)	Link Status - Page 2	1.6.3, 1.6.6	Validation Tests
1.3.1.3.5 (d)	Link PA - Page 1	1.6.4	Validation Tests
1.3.1.3.5 (e)	Link PA - Page 2	1.6.4	Validation Tests

TABLE 6-3. DATEC SOFTWARE S.O.W. COMPLIANCE MATRIX (Cont)

<u>S.O.W. Section No.</u>	<u>Description</u>	<u>Satisfied by Module(s)</u>	<u>Validation</u>
1.3.1.3.5 (f)	Link PA - Page 3	1.6.4	Validation Tests
1.3.1.3.5 (g)	Link PA - Page 4	1.6.4	Validation Tests
1.3.1.3.5 (h)	Maintenance Voltages	1.5.10, 1.6.5, 2.4, 2.5	Validation Tests
1.3.1.4	Nodal Control Operator Interaction	2.0	See below
1.3.1.4 (a)	Link Performance Assessment	2.1	Validation Tests and Scenarios NC, LP, 1, $\left\{ \begin{array}{l} 1 \\ 2 \end{array} \right\}$ Command $\left\{ \begin{array}{l} 3 \\ 4 \end{array} \right\}$
1.3.1.4 (b)	Display Link Status	2.2	Validation Tests System Scenarios NC, LS, 1, $\left\{ \begin{array}{l} 1 \\ 2 \end{array} \right\}$ Command $\left\{ \begin{array}{l} 1 \\ 2 \end{array} \right\}$
1.3.1.4 (c)	Display Site Parameters (Maintenance Voltages)	2.3	Validation Test C System Scenarios NC, MV $\left\{ \begin{array}{l} \text{HUA} \\ \text{SBL} \end{array} \right\}$ Command
1.3.1.4 (d)	Access Alarm Thresholds	2.13, 2.13.1, 2.13.2	Software Log 466 Pages 3, 7, 11, 39, 40, 41 NC, AC, SA $\left\{ \begin{array}{l} \text{HUA} \\ \text{SBL} \end{array} \right\}$ NC, AC, AT, N Commands

TABLE 6-3. DATEC SOFTWARE S.O.W. COMPLIANCE MATRIX (Cont)

<u>S.O.W. Section No.</u>	<u>Description</u>	<u>Satisfied by Module(s)</u>	<u>Validation</u>
1.3.1.4 (e)	Change Alarm Thresholds	2.14, 2.14.1, 2.14.2	Software Log 466 Pages 3,7,11,39, 40,41 Data entered with Change Commands NC,CH,SA {HUA SBL NC,CH,AT,N In-Plant Test Report Section III
1.3.1.4 (f)	Add to Alarm Library	2.14, 2.14.2	Software Log 466 Pages 3,7,11,39, 40,41 Data entered with Change Commands NC,CH,AT,N
1.3.1.4 (g)	Delete from Alarm Library	2.14, 2.14.2	See 1.3.1.4(f)
1.3.1.4 (h)	List Alarm Library	2.13, 2.13.2	Same as 1.3.1.4(f) NC,AC,AT,N Command
1.3.1.4 (i)	Tag Parameters for Statistics	1.14, 2.14.1	In-Plant Test Report Section III Presence of Trending Data in Section II
1.3.1.4 (j)	Reset Parameter Statistics	2.14, 2.14.4 Data Base Generator Program	In-Plant Test Report Section III Field Validation Tests required clearing before test
1.3.1.4 (k)	Return to Normal Nodal Control Scan	2.6	The use of NC,RN: NC,SN Commands

validity of the hardware adaptations; not only from the standpoint of correct or accurate operation, but also with respect to utility or effectiveness.

To best illustrate how the BEM and EPUT were used as effective tools in CPMAS operations, consider the following two test scenarios. The first is a scenario from Appendix R, 13 June 1977, wherein EYE parameters were caused to degrade as a result of abnormal RFI which was introduced at the in-service radio receiver waveguide. Note that the tech controller was able to identify the source of the problem through the use of EYE parameters, Margin and Hits, as processed by the BEM, before it had progressed to the point where BER was excessively degraded. (Derived BER was 1.0×10^{-7} and Tl-4000 FER was still less than 10^{-7} .)

The second scenario (Appendix U', 20 June 1977), illustrating use of the EPUT, was one of many wherein EPUT processed data was utilized in problem identification and isolation. In this case Tl-4000 frame errors counted by the EPUT (from which FER is computed by the PATE), and transient Tl-4000 control reframes latched by the EPUT were used to pinpoint the fault to the "A" multiplexer.

As a result of observing the equipment in operation during test scenarios and from comments from the tech controllers, there was a hardware change made to the EPUT to increase its effectiveness. It was noted in such scenarios as that of Appendix K that occasionally, depending upon the point in the scan, a radio receiver squelch induced by momentarily closing a waveguide shutter would not be displayed following the succeeding scan. The time base (i.e., sample period) of the EPUT was two minutes. The normal scan period (i.e., time between CRT display updates) was between 3-1/2 and 4 minutes. It was therefore possible for the EPUT to latch a transient event, time-out in 2 minutes, and then clear itself by the time it was sampled again by the nodal controller. The occurrence of the transient event was therefore lost. An optimum time base to assure that no data is lost would be slightly less than the normal scan time. The time period chosen was 3-1/2 minutes. Field modification of the EPUT was a relatively simple matter of changing time base strapping on the Command printed circuit board assembly. This is documented in the Ft. Huachuca and Sibyl Hardware Log Books (Pages 2 and 1 respectively).

This modification, however, had its disadvantages too. It slowed down fault isolation. Increasing the time base from 2 minutes to 3-1/2 minutes slows down the process of determining what a frame error rate is, for instance. A dual time base-- 3-1/2 minutes during normal scan and a shorter period during fault isolation procedures-- was considered. This is covered in greater depth in Paragraph 6.1.15 of this section.

PROCEDURE	DATE	TIME															
<p>R1. At the HUA in-service receiver waveguide, using the HP 570-30 Directional Coupler and HP 620B SHF Signal Generator, apply the following frequencies (deviation from center received frequency) at the levels and for the period of time indicated:</p>	6-13-77																
<table border="0"> <thead> <tr> <th><u>Frequency (Rec'd Freq.)</u></th> <th><u>Level</u></th> <th><u>Time</u></th> </tr> </thead> <tbody> <tr> <td>+ 3.15 MHz</td> <td>-20, -30 & -40dBm0</td> <td>TBD</td> </tr> <tr> <td>3.15 MHz</td> <td>-20, -30 & -40dBm0</td> <td>"</td> </tr> <tr> <td>+ 6.3 MHz</td> <td>-20, -30 & -40dBm0</td> <td>"</td> </tr> <tr> <td>- 6.3 MHz</td> <td>-20, -30 & -40dBm0</td> <td>"</td> </tr> </tbody> </table>		<u>Frequency (Rec'd Freq.)</u>	<u>Level</u>	<u>Time</u>	+ 3.15 MHz	-20, -30 & -40dBm0	TBD	3.15 MHz	-20, -30 & -40dBm0	"	+ 6.3 MHz	-20, -30 & -40dBm0	"	- 6.3 MHz	-20, -30 & -40dBm0	"	
<u>Frequency (Rec'd Freq.)</u>	<u>Level</u>	<u>Time</u>															
+ 3.15 MHz	-20, -30 & -40dBm0	TBD															
3.15 MHz	-20, -30 & -40dBm0	"															
+ 6.3 MHz	-20, -30 & -40dBm0	"															
- 6.3 MHz	-20, -30 & -40dBm0	"															
<p>R2. At the completion of step R1, restore equipment to baseline configuration.</p>																	
<p>R3. At HUA, using an HP 606B (or equivalent) test oscillator and the summing amp (a special piece of test equipment) configured as shown in Figure R-1, apply the following frequencies at the levels and for the period of time indicated:</p>																	
<table border="0"> <thead> <tr> <th><u>Frequency</u></th> <th><u>Level</u></th> <th><u>Time</u></th> </tr> </thead> <tbody> <tr> <td>1.544MHz</td> <td>-20 and -30dBm0</td> <td>TBD</td> </tr> <tr> <td>3.088MHz</td> <td>-20 and -30dBm0</td> <td>"</td> </tr> <tr> <td>6.176MHz</td> <td>-20 and -30dBm0</td> <td>"</td> </tr> <tr> <td>12.352MHz</td> <td>-20 and -30dBm0</td> <td>"</td> </tr> </tbody> </table>	<u>Frequency</u>	<u>Level</u>	<u>Time</u>	1.544MHz	-20 and -30dBm0	TBD	3.088MHz	-20 and -30dBm0	"	6.176MHz	-20 and -30dBm0	"	12.352MHz	-20 and -30dBm0	"		
<u>Frequency</u>	<u>Level</u>	<u>Time</u>															
1.544MHz	-20 and -30dBm0	TBD															
3.088MHz	-20 and -30dBm0	"															
6.176MHz	-20 and -30dBm0	"															
12.352MHz	-20 and -30dBm0	"															
<p>R4. At the completion of step R3, restore equipment to baseline configuration.</p>																	
<p>CONDUCTED BY <u>C. L. Christy</u> 6-13-77</p> <p>OBSERVED BY _____</p>																	

6-13-77

<u>Frequency (Rec'd Freq.)</u>	<u>Level</u>	<u>Time</u>
+ 3.15 MHz	-20, -30 & -40dBm0	TBD
3.15 MHz	-20, -30 & -40dBm0	"
+ 6.3 MHz	-20, -30 & -40dBm0	"
- 6.3 MHz	-20, -30 & -40dBm0	"

-60dBm 0920
-55 0925
-50 0930
-45 0934
-43 0940
-40V 0945

CONDUCTED BY C. L. Christy 6-13-77

OBSERVED BY _____

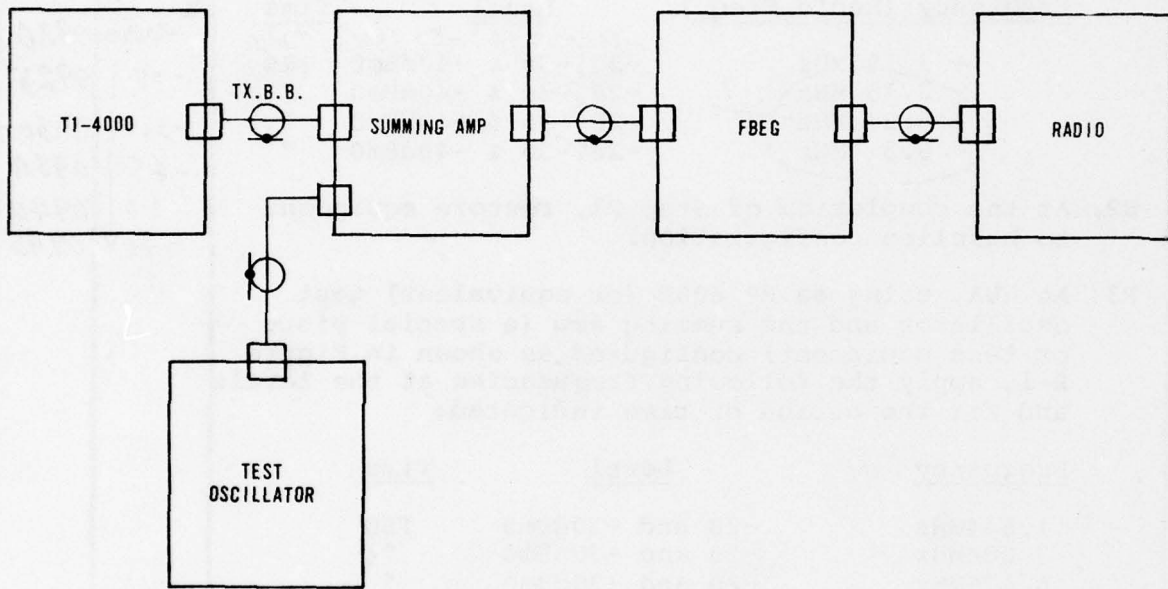

Figure R-1. Test Configuration, RFI at Baseband Level

DATEC SYSTEM EVALUATION WORKSHEET 13 June 77, Pg # 1

OBSERVANCE (key points only)	PRINTOUT REF (ATTACH)	DATE	TIME
Starting new day, with all systems green, and systems da ta attached...///RR	1-4/13 June 77	6/13	0750
Noticed audible alarm (radio), and system switched to "B" recvr here a t HUA...A lso a re on "B" a t SBL...investigating furter ATT...///RR			0851
Back on "A" systems both at HUA & SBL...CRT overview display now indicates the "B" Recvr as amber at HUA...Checking ATT...///RR			0906
LP display, Pg 1 indicates that the "B" Recv RSL marging at a -9..Chking ATT...///RR			0908
Requested maint at HUA check the B" recvr (Front end)...///RR			0910
Systems green again. Maint a dvsd they had a cable off the "B" recvr...///RR.///This was a CWC type problem...///RR			0914
XXXX Link Status display shows low eye margin on HUA rec, Parameter table shows rapid drop in eye margin...Tblshg to locate/isolate pblm.../ph	5/13 June 1977		0940
XXXX Requested maint to swap to "b" rcvr at HUA. .../ph			0943
Swap ba ck to "A" recv at HUA.../cs			0950
Request maint switch SBL's Tx from "A" to "B" Tx./cs			0952
XXXX Suspected rfi on rec from SBL, Maint checking../ph			0959
SBL ha s new XMTR up for testing requested that they s hut down XMTR to see if it is causing RFI ../ph			1002
SBL shut down test XMTR, eye margin data, returned to normal...pblm logged as RFI caused by test XMTR at SBL..../ph			1006
All systems clear at this time../ph			1010
SBL changed back to their "A" transmitter../ph			1014
Trouble caused by a Test XMTR at SBL Site, causing RFI on HUA Rec...			
TECH CONTROLLER _____			
OBSERVED BY _____			

#2 13 June 77

IQ-006 LINK STATUS TIME 164/0753:49
CY-104..... TIMEBI.....
 HUA SRL HUA S3L

ALARM	SERVICE	.	OFFICE	.
	REMOTE	.		.
STATUS	MAINT	.	MAINT	.
PARAMETER	CHANNEL	.	FER <1.0E-6	<1.0E-6
		.	REFRAME	.
SITE ALARMS	ENTRY	.		
	FIRE	.		
	AC PWR	.		
	BATTERY	.		
	W.A. PR	.		
	W.G. HV	.		
	FLOOD	.		

PAGE 2

IAC-1-07-12 LINK PERFORMANCE ASSESSMENT - RADIOS TIME 164/0754:49

		LAST SCAN	LAST HR MEAN	LAST 24 HR MEAN	LAST 24 HR DEV	LAST 30 DAYS MEAN	LAST 30 DAYS DEV	LAST 30 MTIS MEAN	LAST 30 MTIS DEV	
HUA	RSLMAR	30.111	30.195	30.283	.61913	27.134	7.2426			DB
A	EYEMAR	13.369	13.369	13.314	.14364	10.638	3.6644			DB
	RSLAVL	1.0000	1.0000	1.0000		.92543				RATE
	EYEAVL	1.0000	1.0000	1.0000		.91882				RATE
	EYEHIT	0.0	0.0	0.0	0.0	21.872	51.255			ZSC
HUA	RSLMAR	32.018	31.962	31.226	.70834	30.131	2.0384			DB
B	EYEMAR	11.562	11.739	11.616	.32999	7.4473	2.8355			DB
	RSLAVL	1.0000	1.0000	1.0000		.92303				RATE
	EYEAVL	1.0000	1.0000	1.0000		0.9961				RATE
	EYEHIT	0.0	0.0	0.0	0.0	3.7335	4.6243			ZSC
SBL	RSLMAR	30.375	38.822	36.908	1.2709	35.230	1.4460			DB
A	EYEMAR	13.831	13.585	13.477	.28421	13.113	.57164			DB
	RSLAVL	1.0000	1.0000	1.0000		1.0000				RATE
	EYEAVL	1.0000	1.0000	1.0000		0.9980				RATE
	EYEHIT	0.0	0.0	.00100	.00480	1.9380	3.3159			ZSC
SBL	RSLMAR	34.600	33.640	32.051	.92983	33.673	1.3611			DB
B	EYEMAR	13.714	13.748	13.369	.19941	12.819	1.2813			DB
	RSLAVL	1.0000	1.0000	1.0000		1.0000				RATE
	EYEAVL	1.0000	1.0000	1.0000		0.9980				RATE
	EYEHIT	0.0	0.0	0.0	0.0	.93943	2.6463			ZSC
K11	1.0000	1.0000	1.0000		.09338					L11

BEST AVAILABLE COPY

3 13 June 77

AS-2

		LINK PERFORMANCE ASSESSMENT - RADIOS						TIME 161707:3:36		
		LAST SCAN	LAST HR MEAN	LAST 24 HR MEAN	LAST 24 HR DEV	LAST 30 DAYS MEAN	LAST 30 DAYS DEV	LAST 30 DAYS MEAN	LAST 30 DAYS DEV	
HJA	EYEVOL	-3.7600	-3.7600	-3.7649	.01256	-4.0235	.31962	-----	-----	VLIS
	RXSQH	0.0	0.0	0.0	-----	7.0000	-----	-----	-----	RTE
HJA	EYEVOL	-3.9200	-3.9040	-3.8973	.02956	-4.3096	.25981	-----	-----	VLIS
B	RXSQH	0.0	0.0	0.0	-----	12.0000	-----	-----	-----	RTE
HJA	LNKAVL	1.0000	1.0000	1.0000	-----	0.9985	-----	-----	-----	RTE
SBL	EYEVOL	-3.7200	-3.7325	-3.7573	.02432	-3.7640	.01216	-----	-----	VLIS
A	RXSQH	0.0	0.0	0.0	-----	14.0000	-----	-----	-----	RTE
SBL	EYEVOL	-3.7300	-3.7100	-3.7601	.01137	-3.8024	.12208	-----	-----	VLIS
B	RXSQH	0.0	0.0	0.0	-----	9.0000	-----	-----	-----	RTE
SBL	LNKAVL	1.0000	1.0000	1.0000	-----	1.0000	-----	-----	-----	RTE

IO-008

		LINK PERFORMANCE ASSESSMENT - FI-1000						TIME 161707:2:40		
		LAST SCAN	LAST HR MEAN	LAST 24 HR MEAN	LAST 24 HR DEV	LAST 30 DAYS MEAN	LAST 30 DAYS DEV	LAST 30 DAYS MEAN	LAST 30 DAYS DEV	
HJA	FER	1.0E-15	3.0E-16	4.2E-16	-----	5.5E-3	-----	-----	-----	RTE
A	FERAVL	1.0000	1.0000	1.0000	-----	1.0000	-----	-----	-----	RTE
	CRFRM	0.0	0.0	0.0	-----	2.5555	2.5868	-----	-----	RTE
	CR/SQH	0.0	0.0	0.0	-----	1.0000	-----	-----	-----	RTE
	CR/HIT	0.0	0.0	0.0	-----	2.0000	-----	-----	-----	RTE
HJA	FER	1.0E-15	3.3E-17	1.4E-18	-----	1.0E-17	-----	-----	-----	RTE
B	FERAVL	1.0000	1.0000	1.0000	-----	1.0000	-----	-----	-----	RTE
	CRFRM	0.0	0.0	0.0	-----	2.2222	2.3465	-----	-----	RTE
	CR/SQH	0.0	0.0	0.0	-----	1.0000	-----	-----	-----	RTE
	CR/HIT	0.0	0.0	0.0	-----	1.0000	-----	-----	-----	RTE
SBL	FER	1.0E-15	2.7E-16	4.2E-16	-----	5.3E-7	-----	-----	-----	RTE
A	FERAVL	1.0000	1.0000	1.0000	-----	1.0000	-----	-----	-----	RTE
	CRFRM	0.0	0.0	0.0	-----	1.7778	2.1209	-----	-----	RTE
	CR/SQH	0.0	0.0	0.0	-----	1.0000	-----	-----	-----	RTE
	CR/HIT	0.0	0.0	0.0	-----	5.0000	-----	-----	-----	RTE
S	FER	5.2E-10	5.2E-11	2.0E-12	-----	1.3E-7	-----	-----	-----	RTE
B	FERAVL	1.0000	1.0000	1.0000	-----	1.0000	-----	-----	-----	RTE
	CRFRM	0.0	0.0	0.0	-----	1.5555	2.4662	-----	-----	RTE
	CR/SQH	0.0	0.0	0.0	-----	3.0000	-----	-----	-----	RTE
	CR/HIT	0.0	0.0	0.0	-----	3.0000	-----	-----	-----	RTE

#4 13 June 77

MAS LINK PERFORMANCE - SENSORT - TIRMI TIME 16470304:51

		LAST SCAN	LAST HR	LAST 24 HR	LAST 30 DAYS	LAST 3 MONTHS	
		MEAN	MEAN	DEV	MEAN	DEV	MEAN DEV
HJA	FER	1.2E-14	4.0E-15	5.1E-15	4.2E-5		RTE
	RFRM	0.0	0.0	0.0	5.4441	3.9441	RTE
SBL	FER	1.2E-14	3.6E-15	5.1E-15	1.1E-5		RTE
	RFRM	0.0	0.0	0.0	3.4441	3.1096	RTE

IQ-005 MAINTENANCE VOLTAGES - HJA TIME 16470311:40

NO.	NAME	VOLTS	C	RH	AH	CG	AL	RI	MEAN	DEV	INITIAL	DATE
01	T1WB1+15	15.5	G	16.5	15.7	15.0	14.2	13.5	15.5	.040		153/0907
02	T1WB1+12	12.4	G	13.2	12.6	12.0	11.4	10.8	12.4	.037		153/0907
03	T14000+5	4.96	G	5.50	5.25	5.00	4.75	4.50	4.95	.003		153/0907
04	T14000-6	-6.08	G	-5.40	-5.70	-6.00	-6.30	-6.60	-6.08	.009		153/0907
05	RADIO+24	24.0	G	26.4	25.2	24.0	22.8	21.6	23.9	.015		153/0907
06	RADIO-20	-19.0	G	-13.0	-19.0	-20.0	-21.0	-22.0	-19.9	.014		153/0907

MAS MAINTENANCE VOLTAGES - SBL TIME 16470302:51

NO.	NAME	VOLTS	C	RH	AH	CG	AL	RI	MEAN	DEV	INITIAL	DATE
01	T1WB1+15	15.2	G	16.5	15.7	15.0	14.2	13.5	15.2	.009		153/0911
02	T1WB1+12	12.3	G	13.2	12.6	12.0	11.4	10.8	12.3	.012		153/0911
03	T14000+5	4.95	G	5.50	5.25	5.00	4.75	4.50	4.95	.004		153/0911
04	T14000-6	-6.05	G	-5.40	-5.70	-6.00	-6.30	-6.60	-6.04	.004		153/0911
05	RADIO+24	24.1	G	26.4	25.2	24.0	22.8	21.6	24.1	.012		153/0911
06	RADIO-20	-20.1	G	-13.0	-19.0	-20.0	-21.0	-22.0	-20.1	2.4E		153/0911

BEST AVAILABLE COPY

5/13 Jun 77

! NC, AC, SS, HUA
 PAMETER ?9

T1 PERIOD ?H
 01 3.4940 17 OMIT 33 OMIT
 02 11.341 18 OMIT 34 OMIT
 03 13.255 19 OMIT
 04 OMIT 20 OMIT
 05 OMIT 21 OMIT
 06 OMIT 22 OMIT
 07 OMIT 23 OMIT
 08 OMIT 24 OMIT
 09 OMIT 25 OMIT
 10 OMIT 26 OMIT
 11 OMIT 27 OMIT
 12 OMIT 28 OMIT
 13 OMIT 29 OMIT
 14 OMIT 30 OMIT
 15 OMIT 31 OMIT
 16 OMIT 32 OMIT

TIME PERIOD ?

MAC-1-08-10

LINK STATUS
T1-4000.....
 HUA SBL

TIME 164/0941:15
RADIO.....
 HUA SBL

ALARM SW MAJOR
 SW MINOR
 MAJOR
 STATUS TX IN SVC
 RX IN SVC
 MAINT
 PARAMETER FER
 CRFRM
 BER COR

.
 .
 .
 A . A
 A . A
 .
 .
 <1.0E-7 .<1.0E-7
 .
 NO DATA .NO DATA

TX PROB
 RX PROB
 .
 .
 .
 TX IN SVC A . A
 RX IN SVC A . A
 MAINT
 .
 RX SQUELCH
 RSL MARGIN 30.980 . 36.400
 EYE MARGIN 2.0490 . 13.331
 EYE AMPL -8.8065 . -8.2355
 EYE HITS 0.0 . 0.0
 DER BER 2.2E-8 . 8.4E-14
 PAGE 1

MAC-1-08-10

LINK STATUS
T1-4000.....
 HUA SBL

TIME 164/0942:48
RADIO.....
 HUA SBL

ALARM SW MAJOR
 SW MINOR
 MAJOR
 STATUS TX IN SVC
 RX IN SVC
 MAINT
 PARAMETER FER
 CRFRM
 BER COR

.
 .
 .
 A . A
 A . A
 .
 .
 <1.0E-7 .<1.0E-7
 .
 NO DATA .NO DATA

TX PROB
 RX PROB
 .
 .
 .
 TX IN SVC A . A
 RX IN SVC A . A
 MAINT
 .
 RX SQUELCH
 RSL MARGIN 30.980 . 36.400
 EYE MARGIN 2.0490 . 13.331
 EYE AMPL -8.8065 . -8.2355
 EYE HITS 1.1211 A . 0.0
 DER BER 1.1211 A . 0.0

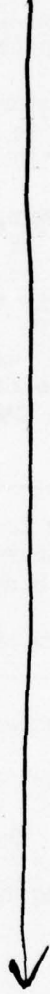
PROCEDURE	DATE
U1. Install the Frame Bit Error Generator (FBEG) between the radio and TI-4000 in the RX base-band input line at SBL <i>HUA</i> .	6-20-77 0800
U2. With the selector switch of the FBEG set to NARROW, repeatedly depress the pushbutton switch several times (3-5). Repeat this operation at a rate of approximately once every 5 minutes. Record the time when each operation is performed.	
<p style="text-align: center;">Perturbation No. 1</p>	0840
<p style="text-align: center;">" " 2</p>	0843
<p style="text-align: center;">" " 3</p>	0846
<p style="text-align: center;">" " 4</p>	0850
<p style="text-align: center;">" " 5</p>	
<p style="text-align: center;">" " 6</p>	
<p style="text-align: center;">" " 7</p>	
<p style="text-align: center;">" " 8</p>	
<p style="text-align: center;">" " 9</p>	
<p style="text-align: center;">" " 10</p>	
<p><i>Requested to switch to B MUX @ 0851</i></p>	
U3. When test is completed, restore equipment to baseline configuration.	
CONDUCTED BY <u>C. L. Christy</u> 6-20-77 OBSERVED BY _____	

DATEC SYSTEM EVALUATION WORKSHEET 20 June 77 Pg # 1

OBSERVANCE (key points only)	PRINTOUT REF (ATTACH)	DATE	TIME
Starting new day, with systems green, and data attached.////RR	1-4/20 June 77	6/20	0845
Overview display indicates the "A " mux at HUA is amber...Letting another scan go thru before doing anything.////RR	5/20 June 77		0846
Link status display indicates the problem with the "A" mux is FER....Requested maint switch HUA to the "B" recv mux.////RR	6/20 June 77		0850
On "B" mux, recv at HUA, and display indicates this is also bad.....However, this could be old data so have to wait for another scan before we can decide if there is any problem with the "B" mux.////RR	7/20 June 77		0857
"B" mux has now cleared, and service appears to be restored....Advised maint to check the "A" mux, Recv at HUA.////RR	8/20 June 77		0900
Problem isolated to bad Recv "A " mux at HUA.. maint advsd problem with the "Recv time base"... System back on the "A " mux ATT.////RR			0913
Displays used.....			
<ol style="list-style-type: none"> 1. System overview 2. Link status Pg #1 			
<p>Note: The length of time required to determine if the "B" mux was good (after putting it on line) was lengthy, due to the scanning sequence/time.////RR</p>			
TECH CONTROLLER	<u></u>		
OBSERVED BY	<u>cm5</u>		

SYSTEM OVERVIEW

*200830
June 77*

RA) A	HUA	SBL
	B	.	.
MUX	SW	.	.
	A	.	.
	B	.	.
CY104		.	.
		.	.
		.	.
		.	.
TIWBI		.	.
		.	.
TELEMETRY		
SITE	:	:	:

Page 1 / 20 June 77

MAS

LINK STATUS
.....T1-4000.....

TIME 17170830:58
.....RADIO.....

		HUA	SBL		HUA	SBL
ALARM	SW MAJOR		.	TX PROB		.
	SW MINOR		.	RX PROB		.
	MAJOR		.			.
STATUS	TX IN SVC	A	.	TX IN SVC	A	A
	RX IN SVC	A	.	RX IN SVC	A	A
	MAINT		.	MAINT		.
PARAMETER	FER	<1.0E-7	.	RX SQUELCH		.
	CRFRM		.	RSL MARGIN	33.405	. 38.200
			.	EYE MARGIN	13.255	. 13.142
	BER COR	NO DATA	.	EYE AMPL	-8.8065	.-8.9677
			.	EYE HITS	0.0	. 0.0
			.	BER BER	1.9E-13	. 2.2E-13
			.			PAGE 1

AS-2

LINK STATUS

TIME 171/0831:45

.....CY-104.....

.....TIWBI.....

		HUA	SBL		HUA	SBL
ALARM	SERVICE	.	.	OFFICE	.	.
	REMOTE
STATUS	MAINT	.	.	MAINT	.	.
PARAMETER	CHANNEL	.	.	FER <1.0E-6	.	<1.0E-6
		.	.	REFRAME	.	.
SITE ALARMS	ENTRY
	FIRE
	AC PWR
	BATTERY
	W.A. PR
	W.G. HV
	FLOOD

PAGE 2

2/20 June 77

HAC-1-07-12

LINK PERFORMANCE ASSESSMENT - RADIOS

TIME 171/0833:07

		LAST SCAN	LAST HR	LAST 24 HR	LAST 30 DAYS	LAST 30 MTHS		
			MEAN	MEAN	MEAN	MEAN	MEAN	DEV
HUA	RSLMAR	33.405	33.256	36.443	0.0	26.777	11.109	----- DB
A	EYEMAR	13.255	13.312	.82140	0.0	11.226	2.9630	----- DB
	RSLAVL	1.0000	1.0000	1.0000	-----	.95173	-----	----- RATE
	EYEA VL	1.0000	1.0000	.66667	-----	.94581	-----	----- RATE
	EYEHIT	0.0	0.0	0.0	0.0	13.514	39.726	----- /SC
HUA	RSLMAR	31.597	31.956	33.898	0.0	27.441	9.5415	----- DB
B	EYEMAR	6.4465	6.4243	9.6676	0.0	7.3166	2.6224	----- DB
	RSLAVL	1.0000	1.0000	1.0000	-----	.99139	-----	----- RATE
	EYEA VL	1.0000	1.0000	1.0000	-----	0.9945	-----	----- RATE
	EYEHIT	.01191	.01191	.29773	0.0	2.8437	5.4650	----- /SC
SBL	RSLMAR	38.000	38.767	39.877	0.0	37.772	2.3974	----- DB
A	EYEMAR	13.142	12.857	11.805	0.0	12.695	2.3493	----- DB
	RSLAVL	1.0000	1.0000	1.0000	-----	.93386	-----	----- RATE
	EYEA VL	1.0000	1.0000	1.0000	-----	1.0967	-----	----- RATE
	EYEHIT	0.0	0.0	0.0	0.0	2.1319	3.5179	----- /SC
SPT	RSLMAR	36.889	37.111	36.667	0.0	33.542	2.5534	----- DB
	EYEMAR	13.028	13.028	12.971	0.0	13.293	1.1823	----- DB
	RSLAVL	1.0000	1.0000	1.0000	-----	.93386	-----	----- RATE
	EYEA VL	1.0000	1.0000	1.0000	-----	1.0987	-----	----- RATE
	EYEHIT	0.0	0.0	.43600	0.0	.53641	2.3368	----- /SC

MAS

LINK PERFORMANCE ASSESSMENT - RADIOS										TIME
										171/0334:04
		LAST SCAN	LAST HR MEAN	LAST 24 HR MEAN	LAST 24 HR DEV	LAST 30 DAYS MEAN	LAST 30 DAYS DEV	LAST 30 MTHS MEAN	LAST 30 MTHS DEV	
HUA	EYEVOL	-3.7700	-3.7650	-5.4767	0.0	-3.9024	.34784	-----	-----	VLTS
A	RXSQH	0.0	0.0	1.0000	-----	29.000	-----	-----	-----	RTE
HUA	EYEVOL	-4.4100	-4.4050	-4.1050	0.0	-4.2700	.24702	-----	-----	VLTS
B	RXSQH	0.0	0.0	1.0000	-----	39.000	-----	-----	-----	RTE
HUA	LNKAVL	1.0000	1.0000	1.0000	-----	.09115	-----	-----	-----	RTE
SBL	EYEVOL	-3.7800	-3.8050	-3.9000	0.0	-3.7337	.43502	-----	-----	VLTS
A	RXSQH	0.0	0.0	0.0	-----	20.000	-----	-----	-----	RTE
SBL	EYEVOL	-3.7900	-3.7900	-3.7950	0.0	-3.6915	.21301	-----	-----	VLTS
B	RXSQH	0.0	0.0	0.0	-----	15.000	-----	-----	-----	RTE
SBL	LNKAVL	1.0000	1.0000	1.0000	-----	0.0093	-----	-----	-----	RTE

3/20 June 77

IQ-005

LINK PERFORMANCE ASSESSMENT - T1-4000										TIME
										171/0835:13
		LAST SCAN	LAST HR MEAN	LAST 24 HR MEAN	LAST 24 HR DEV	LAST 30 DAYS MEAN	LAST 30 DAYS DEV	LAST 30 MTHS MEAN	LAST 30 MTHS DEV	
HUA	FER	5.7E-16	3.3E-17	2.4E-10	-----	5.5E-8	-----	-----	-----	RTE
A	FERAVL	1.0000	1.0000	1.0000	-----	1.0000	-----	-----	-----	RTE
	CRFRM	0.0	2.0000	2.0000	-----	3.8750	4.4704	-----	-----	RTE
	CR/SQH	0.0	0.0	1.0000	-----	22.000	-----	-----	-----	RTE
	CR/HIT	0.0	0.0	0.0	-----	18.000	-----	-----	-----	RTE
HUA	FER	5.7E-16	6.7E-17	8.3E-18	-----	4.2E-19	-----	-----	-----	RTE
B	FERAVL	1.0000	1.0000	1.0000	-----	1.0000	-----	-----	-----	RTE
	CRFRM	0.0	1.0000	2.0000	-----	3.3750	3.9031	-----	-----	RTE
	CR/SQH	0.0	0.0	1.0000	-----	18.000	-----	-----	-----	RTE
	CR/HIT	0.0	0.0	0.0	-----	9.0000	-----	-----	-----	RTE
SBL	FER	5.7E-16	6.7E-17	9.7E-18	-----	8.5E-7	-----	-----	-----	RTE
A	FERAVL	1.0000	1.0000	1.0000	-----	1.0000	-----	-----	-----	RTE
	CRFRM	0.0	1.0000	0.0	-----	1.6875	2.1130	-----	-----	RTE
	CR/SQH	0.0	0.0	0.0	-----	7.0000	-----	-----	-----	RTE
	CR/HIT	0.0	0.0	0.0	-----	5.0000	-----	-----	-----	RTE
SBL	FER	3.0E-10	1.7E-11	1.3E-11	-----	1.3E-7	-----	-----	-----	RTE
B	FERAVL	1.0000	1.0000	1.0000	-----	1.0000	-----	-----	-----	RTE
	CRFRM	0.0	1.0000	0.0	-----	1.5000	1.8708	-----	-----	RTE
	CR/SQH	0.0	0.0	0.0	-----	6.0000	-----	-----	-----	RTE
	CR/HIT	0.0	0.0	0.0	-----	3.0000	-----	-----	-----	RTE

LINK PERFORMANCE ASSESSMENT - TTTT

		LINK PERFORMANCE ASSESSMENT - TTTT						TIME 1712006:05	
		LAST SCAN	LAST HR	LAST 24 HR		LAST 30 DAYS		LAST 30 DAYS	
			MEAN	MEAN	DEV	MEAN	DEV	MEAN	DEV
HL	FER	6.0E-15	8.4E-16	1.5E-2	-----	1.1E-5	-----	-----	-----
	RFR4	4.3	2.0000	2.0000	-----	6.1250	5.9674	-----	-----
SRL	FER	6.9E-15	8.0E-16	1.2E-16	-----	1.5E-5	-----	-----	-----
	RFR4	0.3	1.0000	0.0	-----	3.1675	4.0325	-----	-----

4/20 June 77

MAINTENANCE VOLTAGES - HIA

		MAINTENANCE VOLTAGES - HIA										TIME 1712006:59	
		VOLTS	C	RH	AH	CG	AL	RL	MEAN	DEV	INITIAL	DATE	
01	T1WB1+15	15.6	G	16.5	15.7	15.0	14.2	13.5	15.6		0	153/0987	
02	T1WB1+12	12.4	G	13.2	12.6	12.4	11.4	11.8	12.4		0	153/0987	
03	T14000+5	4.95	G	5.50	5.25	5.00	4.75	4.50	4.96		0	153/0987	
04	T14000-6	-6.00	G	-5.40	-5.70	-6.00	-6.30	-6.60	-6.00		0	153/0987	
05	RADIO+24	23.9	G	26.4	25.2	24.1	22.8	21.6	23.9		0	153/0987	
06	RADIO-20	-19.9	G	-18.0	-19.0	-20.4	-21.0	-22.0	-19.9		0	153/0987	

MAINTENANCE VOLTAGES - SRL

		MAINTENANCE VOLTAGES - SRL										TIME 1712007:45	
		VOLTS	C	RH	AH	CG	AL	RL	MEAN	DEV	INITIAL	DATE	
01	T1WB1+15	15.1	G	16.5	15.7	15.0	14.2	13.5	15.1		0	153/0911	
02	T1WB1+12	12.3	G	13.2	12.6	12.0	11.4	11.8	12.3		0	153/0911	
03	T14000+5	4.95	G	5.50	5.25	5.00	4.75	4.50	4.95		0	153/0911	
04	T14000-6	-6.05	G	-5.40	-5.70	-6.00	-6.30	-6.60	-6.05		0	153/0911	
05	RADIO+24	24.3	G	26.4	25.2	24.0	22.8	21.6	24.0		0	153/0911	
06	RADIO-20	-20.1	G	-18.0	-19.0	-20.0	-21.0	-22.0	-20.1		0	153/0911	

#5
20 June 77

```
AS-2
RA.  A
    B
MUX SW
  A
  B
CY104

TINBI

TELEMETRY.
SITE
```

```
      HUA      SBL
      .        .
      .        .
      .AI<     .
      .        .
      .        .
      .        .
      .        .
      .        .
      .        .
      .        .
      .AI<     .
      .        .
      .        .
```

SYSTEM OVERVIEW

TIME 17170343:14

```
AS-2
RADIO A
    B
MUX SW
  A
  B
CY104

TINBI

TELEMETRY.
SI
```

```
      HUA      SBL
      .        .
      .        .
      .AI<     .
      .        .
      .        .
      .        .
      .        .
      .        .
      .        .
      .        .
      .        .
      .        .
      .        .
```

SYSTEM OVERVIEW

TIME 17170346:16

#6 20 June 77

IQ-008

LINK STATUS
.....T1-4000.....
HUA SBL

TIME 171/0517:01
.....RADIO.....
HUA SBL

ARM	SW MAJOR	.	TX PROB	.
	SW MINOR	.	RX PROB	.
	MAJOR	.		.
STATUS	TX IN SVC	A . A	TX IN SVC	A . A
	RX IN SVC	A . A	RX IN SVC	A . A
	MAINT	.	MAINT	.
PARAMETER	FER	1.2E-6 R.<1.0E-7	RX SQUELCH	.
	CRFRM	* .	RSL MARGIN	33.405 . 37.000
			EYE MARGIN	13.142 . 12.914
	BER COR	6.7436 R.NO DATA	EYE AMPL	-8.8307 .-8.2077
			EYE HITS	3.4 . 3.4
			DER BER	2.2E-13 . 3.0E-13

PAGE 1

IQ-005

SYSTEM OVERVIEW

TIME 171/0512:07

	HUA	SBL
RADIO A	.	.
B	.	.
MUX SV	.R<>	.
A	.AS<	.
B	.	.
CY1/4	.	.
	.	.
	.	.
	.	.
	.	.
	.	.
	.	.
	.	.
	.	.
	.	.
TELEMETRY.	.	.
SECS	.	.

#7 28 June 77

MAC-3-01-06

SYSTEM OVERVIEW

TIME 17170854:58

	HUA	SBL
RADTO A	.	.
B	.	.
MUX SW	.R<>	.
A	.AS<	.
B	.AI<	.
CY104	.	.
	.	.
	.	.
	.	.
	.	.
	.	.
	.	.
	.	.
	.	.
	.	.
	.	.
TTWB1	.A01<	.
	.	.
	.	.
TELEMETRY.	
	.	.
SITE	.	.

AS-2

LINK STATUS

TIME 17170857:51

	HUA	SBL	RADIO
ALARM	SW MAJOR	.	.
	SW MINOR	*	.
	MAJOR	.	.
STATUS	TX IN SVC	A	A
	RX IN SVC	B	A
	MAINT	.	.
PARAMETER	FER	9.7E-6 R.<1.0E-7	.
	CRFRM	*	.
	BER CR	7.7018 R.NO DATA	.
	TX PROB	.	.
	RX PROB	.	.
	TX IN SVC	A	A
	RX IN SVC	A	A
	MAINT	.	.
	RX SQUELCH	.	.
	RSL MARGIN	33.524	38.200
	EYE MARGIN	13.369	12.687
	EYE AMPL	-8.8065	-8.9677
	EYE HITS	0.0	0.0
	DER BER	1.6E-13	4.0E-13

PAGE 1

#8 28 June 77

AS-2

LINK STATUS
T1-4000.....
 HUA SBL

TIME 17170359:20
RADIO.....
 HUA SBL

LARM	SW MAJOR	*	.	TX PROB	.	
	SW MINOR	.	.	RX PROB	.	
	MAJOR	.	.		.	
STATUS	TX IN SVC	A	.	TX IN SVC	A	A
	RX IN SVC	B	.	RX IN SVC	A	A
	MAINT	.	.	MAINT	.	
PARAMETER	FER	<1.0E-7	.	RX SQUELCH	.	
	CRFRM	.	.	RSL MARGIN	33.524	. 38.270
	BER COR	NO DATA	.	EYE MARGIN	13.360	. 12.687
		NO DATA	.	EYE AMPL	-8.9965	. -8.9677
			.	EYE HITS	0.0	. 0.0
			.	OPR BER	1.6E-13	. 4.0E-13

PAGE 1

AS

SYSTEM OVERVIEW

TIME 171703 M:10

	HUA	SBL
RADIO A	.	.
B	.	.
RX SW	.R<>	.
A	.AS<	.
3	.	.
CY104	.	.
	.	.
	.	.
	.	.
	.	.
	.	.
	.	.
	.	.
TELEMETRY.	.	.
SI :	.	.

There were also hardware changes made to the BEM Active Coupler (BAC) and to the BEM itself during the field test phase. The gain of the BAC was originally designed to accommodate a baseband composite RMS level of -7 dBm (determined during an early site survey) so as to provide a nominal 0.309 volt RMS to the BEM input circuits. A 100 ohm potentiometer was used to adjust for slight variations around the -7 dBm level. When the field tests began, however, it was noted that the baseband level was set in the receiver to -9 dBm. The 100 ohm potentiometer was, therefore, changed to 500 ohms to provide a wider range of gain adjust.

Further changes were made to the BAC and to the BEM to assure compatibility of the BEM with the DR8A baseband monitor point. Following are those changes and the reasons for them:

<u>Unit</u>	<u>Change</u>	<u>Reason</u>
BAC	Input resistance from 75 ohms to 560 ohms	Obtain the correct input voltage level to the BAC amplifier.
BEM	Xtal frequency in Receive Input Unit from 12.5533 MHz to 6.2765 MHz; tuning coil from 7 - 14 μ H to 14 - 28 μ H	Input to BEM is either the in-phase or quadrature signal from DR8A which is 6.3 MHz
BEM	Output filter added to Dispersion Voltage output to MAC	Smooth out (average) dispersion voltage changes due to PLL lock-up state changes in demodulator of DR8A
BEM	Voltage divider which sets threshold window for Hits changed to effectively narrow the window.	To maintain the same relative Hit count under similar RSL conditions. Since system had higher BER with DR8A and also more hits, the Hit window was narrowed such that amber and red thresholds related to nominal DR8A operation as they did for nominal AN/FRC-162 operation.

As a supplement to the Validation tests and System Simulation Scenarios which were conducted during field tests, additional data was collected to show correlation of BEM derived bit error rate (BER) with that measured using a BER tester. This was done when the AN/FRC-162 radio was being used and again later when the DR8A radio was in service. This data, shown in Tables 6-4 and 6-5 indicates correlation well within one order of magnitude which was the design goal for the BEM. Table 6-6 presents data that was taken during in-plant tests of the BEM, and is included here to show correlation down to a BER in the order of 10^{-9} .

TABLE 6-4. BEM DER BER VERSUS MEASURED BER, AN/FRC-162

<u>DER BER</u>	<u>BER (Meas)</u>	<u>RSL (dBm, Ref)</u>
7.3 x 10 ⁻¹³	<10 ⁻⁸	-37
1.7 x 10 ⁻¹²	<10 ⁻⁸	-46
2.0 x 10 ⁻¹²	<10 ⁻⁸	-57
1.4 x 10 ⁻¹¹	<10 ⁻⁸	-62
9.3 x 10 ⁻¹⁰	<10 ⁻⁸	-68
2.1 x 10 ⁻⁹	<10 ⁻⁸	-70
2.6 x 10 ⁻⁷	9.0 x 10 ⁻⁸	-72
1.3 x 10 ⁻⁶	3.0 x 10 ⁻⁶	-73
3.9 x 10 ⁻⁵	2.7 x 10 ⁻⁵	-74
2.0 x 10 ⁻⁴	1.3 x 10 ⁻⁴	-75
4.9 x 10 ⁻⁴	5.3 x 10 ⁻⁴	-76
9.4 x 10 ⁻⁴	1.6 x 10 ⁻³	-77

TABLE 6-5. BEM DER BER VERSUS MEASURED BER, DR8A

<u>DER BER</u>	<u>BER (Meas)</u>	<u>RSL (dBm, Ref)</u>
3.1×10^{-10}	$<10^{-8}$	-75
1.4×10^{-9}	$<10^{-8}$	-80
2.8×10^{-9}	$<10^{-8}$	-82
6.9×10^{-9}	3.0×10^{-8}	-84
1.3×10^{-8}	4.0×10^{-8}	-85
3.0×10^{-8}	6.0×10^{-8}	-86
4.0×10^{-8}	1.2×10^{-7}	-87
1.9×10^{-7}	4.6×10^{-7}	-88
7.4×10^{-7}	1.3×10^{-6}	-89
5.0×10^{-6}	5.0×10^{-6}	-90
5.4×10^{-6}	1.3×10^{-5}	-91
2.7×10^{-4}	4.5×10^{-5}	-92
9.6×10^{-4}	2.0×10^{-4}	-93

TABLE 6-6. BEM DER BER VERSUS MEASURED BER, LABORATORY

<u>DER BER</u>	<u>BER (Meas)</u>
7.8×10^{-11}	7.5×10^{-10}
2.0×10^{-10}	6.1×10^{-10}
7.8×10^{-9}	8.0×10^{-9}
1.3×10^{-7}	6.6×10^{-8}
6.6×10^{-6}	5.1×10^{-6}
4.3×10^{-5}	3.8×10^{-5}
5.7×10^{-4}	5.3×10^{-4}

6.1.4 The DATEC Capability to Accomplish Sudden Service Failure Sensing (SSFSS), Omnistratametric Monitoring, and Nodal Control Monitoring

The SSFSS function was fully validated by Appendix A Procedures during the validation phase of field tests (refer to Section II, of the Field and Evaluation Report). If a major alarm signifying loss of service occurs, it is sensed and displayed on the Alarm Scanner at the site and at the nodal control Alarm Display within four seconds. The top or primary CRT display for major alarm monitoring is the System Overview page, which is the "home" or starting position for nodal control monitoring. Within 30 seconds after occurrence, a major alarm will be displayed on the System Overview; the highest alarm (in terms of the communication system hierarchy) at a particular site will be blinking. Omnistratametric monitoring is available at the System Overview in the form of hard equipment alarms and parameter alarms, and expands into the lower display pages (Link Status, Link P.A. and Maintenance Voltages) where key parameters from all levels of the communication system are alarmed and trended. Section II of the field test report deals with the quantitative aspects of this subject. The following examples-- excerpts from the System Simulation Scenarios-- were chosen to illustrate the feasibility of nodal control and the effectiveness of omnistratametric monitoring.

The best example to illustrate complete monitoring through all levels of the communication system is a scenario involving problems at all levels. Appendix EE was intended to test DATEC's effectiveness as a tool in recognizing and isolating multiple, unrelated failures. Note that the problems were first observed at the System Overview level and then traced downward through the lower tier displays to their source. In a particular example, the scenario conducted on 21 June 1977, a total of 4 separate, unrelated problems were identified and isolated in a period of approximately 20 minutes.

Another scenario which presented a wide range of problems for the Tech Controller to solve was Appendix FF. The tech controller accurately notes in the scenario on 20 June 1977 that he could not have isolated all the faults using the System Overview; however, it will be noted that this display was frequently used as a starting point in problem isolation and presented a good overall picture of the link's operational status at any given time as the scenario progressed. It proved useful, then, in the process of nodal control.

6.1.5 The DATEC Performance in Both the Active Scan and the Special Request Modes of Operation



In addition to the active or normal scan mode of operation, there are two other modes that can be entered via operator interaction. These are Monitor Immediate and Self-Test.

UNRELATED MULTIPLE FAILURES-1

PROCEDURE	DATE	TIME
EE1. At SBL, insert 10dB of attenuation in the A receiver waveguide attenuator.	6-21-77	1558
EE2. At SBL, inject ≈ 6 T1-4000 frame errors every 2-4 minutes using the FBEG. This is to be done with the NORMAL T1-4000 in service.		
EE3. At HVA, disable the NORMAL T1-4000 Channel 7 XMIT card by breaking the card edge connections to the cardrest.		
EE4. At HVA, inject a $2600 \text{ Hz} \pm 10 \text{ Hz}$ at -20 dBm ; also inject $1000 \text{ Hz} \pm 10 \text{ Hz}$ at -44 dBm .		
EE5. At HVA, remove the CONV. fuse from the TIWB1.		
EE6. Upon completion of the test, return all conditions to normal.		

CONDUCTED BY C L Christy 6-21-77
 OBSERVED BY _____

DATEC SYSTEM EVALUATION WORKSHEET 21 June 77 , Pg # 5

OBSERVANCE (key points only)	PRINTOUT REF (ATTACH)	DATE	TIME
Systems again Green...////RR		6/21	1540
System overview indicates Amber Inservice radio at SBL...../ph	9/21 June 77		1557
Link status page one indicates amber RSL on SBL rec..../ph	9/21 June 77		1558
TLWBL HUA?SEL in red att..../ph	10/21 June 77		1559
Request that maint pull in house loop on the TLWBL at HUA and SEL..../ph			1600
Maint advise KHUA has a bad TLWBL..../ Still xx showing low RSL on the "A" Radio at SEL../cs			1602
Request SEL lock on his "B" Radio Rx, RSL problem on "A" Rx...Maint cont work on HUA's TL WBL../cs	11/21 June 77		1605
Maint replace blown fuse on TLWBL at HUA.,, still xx have a major alarm on same../cs	12/21 June 77		1606
SEL had a bad IF in their "A" Rx is being worked on now../Request Maint at SBL and HUA replace both Rx and Tx cards in the TL-4000 mux			1609
Major alarm on TLWBL at HUA is cleared,,have an amber Rx on "B" radio at HUA../cs..Amber condition caused by low eye margin../cs	12/21 June 77		1612
Maint advise bad Tx channel card at HUA and was replaced,,, also showing an amber con on the "A" mux at SEL../cs			1618
Amber con on the TL-4000 ca used by xxx a bad Rx card at SBL ../cs			1621
<p>Problems Isolated Too:</p> <ol style="list-style-type: none"> 1. Blown fuse on the TLWBL at HUA 2. Bad IF in the "A" Recvr at SBL 3. Bad Xmit chnl card (chnl 7) on TL-4000 at HUA 4. Bad Recv common card in the TL-4000 at SBL 			
<p>Displays deemed useful</p> <ol style="list-style-type: none"> 1. System Overview (initial indication) 2. Link Status, Pg # 1 3. Link Performance, Pg # 1 			
TECH CONTROLLER			
OBSERVED BY			

MAS
 RADIO A
 HUA
 SBL
 >IA
 CY104
 TIWBI
 TELEMETRY.
 SITE

SYSTEM OVERVIEW

TIME 172/1557:35

#9 21 June 77

MA-2

LINK STATUS

TIME 172/1553:56

	TI-4000.....		MAJOR ALARM	RADIO.....	
		HUA	SBL			HUA	SBL
ALARM	SW MAJOR		.				
	SW MINOR		.				
	MAJOR		.				
STATUS	TX IN SVC	A	A	TX IN SVC	A	A	
	RX IN SVC	A	A	RX IN SVC	A	A	
	MAINT		.	MAINT		.	
PARAMETER	FER	<1.0E-7	<1.0E-7	RX SQUELCH		.	
	CRFRM		.	RSL MARGIN	33.048	28.417	A
	BER COR	NO DATA	NO DATA	EYE MARGIN	12.346	12.459	
				EYE AMPL	-8.9677	-8.9355	
				EYE HITS	0.0	0.0	
				DER BER	6.2E-13	5.5E-13	

UNRELATED MULTIPLE PROBLEMS, 2

PROCEDURE	DATE	TIME
FF1. At SBL, fail TX A by disconnecting the XMIT pilot at J105/P105 cable connector.	6-20-77	1322
FF2. At SBL, insert 10dB attenuation in the B waveguide attenuator.		1322
FF3. At SBL, remove the fuse from the STBY TI-4000.		1322
FF4. At SBL, using the FBEG in the SHORT mode insert \approx 6 frame errors every 2-4 minutes		
FF5. At SBL, remove the Channel 7 Receive Card from the TI-4000 A unit		1328
FF6. At HVA, place the B Transceiver in Maintenance (Lock RX on A)		1336
FF7. At HVA, insert 33dB atten. in the "A" IF attenuator inserted between the Equalizer and the IF amp.		1336
FF8. At HVA, inject $F_0 + 6.3$ MHz into both the "A & B" receivers. Set the level to -50dBm.		
FF9. At SBL, connect one side of CY-104 Channel 1 Receive filter, FL-1 to ground.		
FF10. Upon completion of testing return the equipment to NORMAL configuration.		1402

Requested switchover to A mux @ 1340 - replaced fuse @ that time.
 Reconnected p.c.s/p.c.s @ 1342. Removed attenuation from B waveguide at 1348.

CONDUCTED BY

C. L. Christy 620-77

OBSERVED BY

Removed atten. from A RX @ HVA at 1402

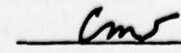
OBSERVANCE (key points only)	PRINTOUT REF (ATTACH)	DATE	TIME
Systems again Green...///RR		6/20	1245
Overview indicates problems with "A" radio at SBL, "B" mux at SEL, and also shows both radios at HUA amber...Displays indicate that the TL-4000 is Red...///RR	15/20 June 77		1322
Requested maint at SBL, switch to their "A" mux (to restore service)...///RR			1326
A gain requested maint at SEL switch to their "A" mux...not done as yet....They advsd that they had blown fuse in "B" mux, causing this to go red...They replaced same....			1336
Requested SBL check their "A" Xmitter as display shows it bad...Also requested they check output power on "B" xmtr, as our RSL is low...They advsd they back on "A" mux ATT...///RR	17/20 June 77 18/20 June 77		1337
SBL maint advsd of brkn wire on the "A" Xmitter and they repaired same.. and placed the "A" Xmitter on the air...///RR	19/20 June 77		1343
Requested SBL checker their antenna alignment due to low RSL'S on both at HUA, and on "B" a t SBL.....They also advsd tha t the "B" xmtr had output pwr problem, which they corrected...//RR			1346
Maint advsd no problem with antenna's...Showing RED Flag on the TLWBL, here andx at SBL..Requested both HUA and SBL place the TLWBL in loop to chker out...///RR			1353
Maint advs both TLWBL loops good...Requested they check chnl cards on the TL4000 for the TLWBL chnl...//RR	20/20 June 77		1355
Chnls on TL4000 at HUA good, requested SBL chk his chnls...///RR			1357
SBL maint advs he had bad recv chnl on his TL-4000 replaced card...///Also, ATT requested HUA maint check the "A" recvr as still showing low RSL...//RR	21/20 June 77		1359
Maint advsd of bad IF in "A" recvr at HUA, repaired same and back on line...///RR			1402
Systems all clear and green...///RR			1413
<p style="text-align: right;">CONT ON PAGE # 5</p> <p>TECH CONTROLLER <u></u></p> <p>OBSERVED BY <u></u></p>			

AD-A051 926

HONEYWELL INC ST PETERSBURG FL AVIONICS DIV
ATEC DIGITAL ADAPTATION STUDY, DEVELOPMENT AND FIELD EVALUATION--ETC(U)
JAN 78 T J CAMPBELL, W F ACKER, C L CHRISTNER F30602-75-C-0282

F/G 17/2

UNCLASSIFIED

1077-14813-VOL-2

RADC-TR-77-431-VOL-2



NL

2 of 4
AD
A051926



DATEC SYSTEM EVALUATION WORKSHEET

20 June 77, Pg # 5

OBSERVANCE (key points only)	PRINTOUT REF (ATTACH)	DATE	TIME
<p>PROBLEMS ISOLATED TO (cont frm pg # 4)</p> <ol style="list-style-type: none"> 1. Bad "A" Recv radio at HUA (bad IF) 2. Bad "A" xmittr radio at SBL (Brkn wire) 3. Bad "B" xmittr at SBL (low output pwr) 4. Blown fuse in "B" mux at SBL 5. Bad recv chnl card on TL-4000 at SBL 			
<p>Most useful displays....</p> <ol style="list-style-type: none"> 1. LS, Pg # 1 2. LP, Pg # 1 3. LS, Pg # 2 <p>NOTE: Although the overview was useful in initially showing there were problems, I don't feel I could have isolated these problems by just using the OverView...///RR</p> <p>TECH CONTROLLER <u></u></p> <p>OBSERVED BY <u></u></p>			

#16 20 June 77

MA			SYSTEM OVERVIEW	TIME 171/1327:14
	HUA	SBL		MAJOR ALARM
RADIO A	.AI<	<SR.		
B	.AS<	>SA.		
MUX SW	.	<>R.		
A	.AI<	.		
B	.	<>R.		
CY104	.	.		
	.	.		
	.	.		
	.	.		
	.	.		
	.	.		
	.	.		
	.	.		
	.	.		
	.	.		
	.	.		
	.	.		
	.	.		
	.	.		
TIWBI	.AØI<	.		
	.	.		
TELEMETRY.		
SITE	.	.		

MA-2			SYSTEM OVERVIEW	TIME 171/1331:24
	HUA	SBL		MAJOR ALARM
RADIO A	.AI<	<SR.		
B	.AS<	>SA.		
MUX SW	.	<>R.		
A	.	.		
B	.	<>R.		
CY104	.	.		
	.	.		
	.	.		
	.	.		
	.	.		
	.	.		
	.	.		
	.	.		
	.	.		
	.	.		
	.	.		
	.	.		
	.	.		
	.	.		
	.	.		
	.	.		
	.	.		
TIWBI	.RØI<><>ØIR.	.		
	.	.		
TELEMETRY.		
SITE	.	.		

AS-2

LINK STATUS

TIME 171/1334:20

.....T1-4000.....

.....RADIO.....

		HUA	SBL		HUA	SBL
ALARM	SW MAJOR	.	*	TX PROB	.	A
	SW MINOR	.	*	RX PROB	.	A
	MAJOR	.	B		.	
STATUS	TX IN SVC	A	B	TX IN SVC	A	B
	RX IN SVC	A	B	RX IN SVC	A	A
	MAINT	.	.	MAINT	.	.
PARAMETER	FER	<1.0E-7	.00017 R	RX SQUELCH	.	.
	CRFRM	.	*	RSL MARGIN	18.113 R.	40.773
	BER COR	NO DATA	. 8.5506 R	EYE MARGIN	15.290	. 12.637
				EYE AMPL	-9.3704	-.8.9677
				EYE HITS	0.0	. 0.0
				DER BER	1.0E-15	. 4.0E-13

PAGE 1

#17 20 June 77

MA-2

SYSTEM OVERVIEW

TIME 171/1340:30

MAJOR ALARM

	HUA	SBL
RADIO A	.RS<	<SR.
B	.AI<	>SA.
MUX SW	.	.
A	.	.
B	.	.
CY104	.	.
	.	.
	.	.
	.	.
	.	.
	.	.
	.	.
TINBI	.RM1<>>31R.	.
	.	.
TELEMETRY.	.	.
S E	.	.

AS-2		LINK PERFORMANCE ASSESSMENT - RADIOS					TIME 171/1342:38		
	LAST SCAN	LAST HR MEAN	LAST 24 HR MEAN	LAST 24 HR DEV	LAST 30 DAYS MEAN	LAST 30 DAYS DEV	LAST 24 MTHS MEAN	LAST 24 MTHS DEV	
HUA	RSLMAR-9.0000	15.222	32.774	2.0000	27.258	1.947	-----	-----	DB
	EYEMAR 15.290	14.329	12.915	4.2686	16.985	3.8315	-----	-----	DB
	RSLAVL 0.0	.71429	1.0000	-----	.95196	-----	-----	-----	RATE
	EYEA VL 1.0000	1.0000	.97436	-----	.94553	-----	-----	-----	RATE
	EYEHIT 0.0	0.0	9.2710	12.160	12.712	30.671	-----	-----	/SC
HUA	RSLMAR 21.044	26.308	32.214	.79179	27.383	9.3573	-----	-----	DB
B	EYEMAR 3.9786	8.3161	6.8315	1.2755	7.3391	2.5446	-----	-----	DB
	RSLAVL 1.0000	1.0000	1.0000	-----	.92143	-----	-----	-----	RATE
	EYEA VL 1.0000	1.0000	1.0000	-----	1.0246	-----	-----	-----	RATE
	EYEHIT 0.0	.0956	.05286	.10960	3.6265	5.3731	-----	-----	/SC
SBL	RSLMAR 43.778	43.286	39.297	.67077	37.851	2.3474	-----	-----	DB
A	EYEMAR 12.687	12.762	12.615	.33211	12.675	2.2423	-----	-----	DB
	RSLAVL 1.0000	1.0000	1.0000	-----	.93393	-----	-----	-----	RATE
	EYEA VL 1.0000	1.0000	1.0000	-----	0.9967	-----	-----	-----	RATE
	EYEHIT 0.0	0.0	0.0	4.3	2.0365	3.4495	-----	-----	/SC
SBL	RSLMAR 28.933	34.613	37.399	.68436	33.725	2.5847	-----	-----	DB
B	EYEMAR 12.573	12.573	13.143	.15000	13.283	1.1471	-----	-----	DB
	RSLAVL 1.0000	1.0000	1.0000	-----	.95323	-----	-----	-----	RATE
	EYEA VL 1.0000	1.0000	1.0000	-----	0.9987	-----	-----	-----	RATE
	EYEHIT 0.0	0.0	.00600	.01342	.54592	1.9797	-----	-----	/SC

#18 20 June 77

MA-2	SYSTEM OVERVIEW		TIME 171/1344:29
	HUA	SBL	MAJOR ALARM
RADIO A	.RS<	.	
B	.AI<	>SA.	
MUX SA	.	.	
A	.	.	
B	.	.	
CY104	.	.	
	.	.	
	.	.	
	.	.	
	.	.	
	.	.	
T1WB1	.R01<>>01R.	.	
	.	.	
TELEMETRY.	.	.	
SITE	.	.	

BEST AVAILABLE COPY

#19 20 June 77

1A-2 SYSTEM OVERVIEW TIME 171/1359:13

	INIA	SBL	MAJOR BLA
RADIO A	.AS<	.	
B	.	>SA.	
WIA S1	.	.	
A	.	.	
B	.	.	
CY104	.	.	
	.	.	
	.	.	
	.	.	
	.	.	
	.	.	
T1B1	.R41<><>.R1R.	.	
	.	.	
TELEMETRY.
SITE	.	.	.

MAC-1-18-23 MAINTENANCE VOLTAGES - HV TIME 171/1359:40

NO.	NAME	VOLTS	C	RH	AH	CS	AL	RL	MEAN	DEV	INITIAL	DATE
01	T1B1+15	15.6	G	16.5	15.7	15.3	14.2	13.5	15.5	.321		153/1987
02	T1B1+12	12.3	G	13.2	12.6	12.0	11.4	10.8	12.3	.387		153/1987
03	T14000+5	4.94	G	5.50	5.25	5.00	4.75	4.50	4.95	.381		153/1987
04	T14000-6	-5.08	G	-5.40	-5.70	-6.00	-6.30	-6.60	-5.63			153/1987
05	RADIO+24	23.9	G	25.4	25.2	24.7	22.8	21.6	23.9	.321		153/1987
06	RADIO-24	-19.2	G	-18.0	-19.0	-20.0	-21.0	-22.0	-19.0	.095		153/1987

BEST AVAILABLE COPY

#20 20 Jun 77

MA-1-18-23

		LINK STATUS		TIME 171/1351:41	
	CY-194.....	TIME.....	
		HJA	SBL	HJA	SBL
ALARM	SERVICE	.	.	OFFICE	* . *
	REMOTE	.	.		.
STATUS	MAINT	.	.	MAINT	.
PARAMETER	CHANNEL	.	.	FER	.01953 R. .01953 R
		.	.	REFRAME	* . *
SITE ALARMS	ENTRY	.	.		
	FIRE	.	.		
	AC PWR	.	.		
	BATTERY	.	.		
	W.A. PR	.	.		
	W.G. HV	.	.		
	FLOOD	.	.		

PAGE 2

MA-2

		LINK STATUS		TIME 171/1356:25	
	T1-4000.....		MAJOR ALARM	
		HJA	SBLRADIO.....	
		HJA	SBL	HJA	SBL
ALARM	SW MAJOR	.	.	TX PROB	.
	SW MINOR	.	.	RX PROB	.
	MAJOR	.	.		.
STATUS	TX IN SVC	A	A	TX IN SVC	A . B
	RX IN SVC	A	A	RX IN SVC	B . A
	MAINT	.	.	MAINT	.
PARAMETER	FER	.03162 R.	<1.0E-7	RX SQUELCH	.
	CRFRM	*	*	RSL MARGIN	30.927 . 40.773
				EYE MARGIN	8.9786 . 12.687
	BER COR	10.579 R.	NO DATA	EYE AMPL	-9.5556 . -8.9677
				EYE HITS	0.0 . 0.0
				DER BER	4.3E-14 . 4.0E-13

PAGE 1

#21 20 June 77

```

      MAS
      SBL
RADIO A  HHA  .AS<
  B      .
MUX SW   .
  A      .AI<
  B      .
CY104    .
        .
        .
        .
        .
        .
        .
        .
        .
        .
        .
TIMBI    .A01< >01A.
        .
        .
.....
TELEMETRY.
SITE     .      .      .

```

SYSTEM OVERVIEW

```

      SBL
RADIO A  HHA  .
  B      .
MUX SW   .
  A      .AI<
  B      .
CY104    .
        .
        .
        .
        .
        .
        .
        .
        .
        .
        .
TIMBI    .      .>01A.
        .
        .
.....
TELEMETRY.
SITE     .      .      .

```

SYSTEM OVERVIEW

TIME 17171402:20

The Monitor Immediate mode was implemented just prior to field tests and replaced another similar mode called Temporary Scan, which was in use during in-plant tests at Honeywell. This mode features an abbreviated scan which monitors only those parameters selected by the operator in the nodal command statement entered via the keyboard. Proper operation of this mode was verified by the validation test procedures of Appendix B of the Field Test Plan and Procedures. During System Simulation Scenarios, it proved to be a very effective and time-saving tool which the tech controllers used extensively. It was very useful in verifying hard communication system failures as opposed to momentary transients which might have appeared on the CRT display during normal scanning. For a radio parameter derived from the Baseband Eye Monitor, it would take between 7 and 8 minutes for such a condition to clear. In the Monitor Immediate mode, eye parameters can be rescanned in a matter of seconds.

Appendix N, 14 June 1977, simulating malalignment of both antennas at Sibyl, serves as one example of the usefulness of this mode. Observing Link P.A., Page 1, while in Monitor Immediate, gave the Tech Controller an almost real-time picture of the problem.

Another example of use of the Monitor Immediate mode was illustrated during conduction of an Appendix U scenario on 8 June 1977. In this case the parameters being monitored (RSL Margin and Eye Margin), were not the source of the problem; however, by being able to use Monitor Immediate mode and get quick updates, the tech controller was able to determine this without having to wait for the normal scan to update the parameters.

Use of the Self-TEst mode was not written into the Field Test Plan/Procedures document. This was an oversight. This mode of operation, however, was put to use several times during the field test phase of the program. In this mode, the MAC, EPUT, or BEM units may be individually addressed while in Operator Interaction and commanded to enter the self-test mode. The unit is caused to act upon stimuli generated internally in place of active data input, and to output a known result. The unit is then queried by the nodal control software and caused to transmit its data in the same manner as it would during a normal scan. The results-- GO or NO GO-- are then displayed on the CRT display.

Although there were no tests written into the Test Plan/Procedures document to demonstrate the Self-Test mode, there are nevertheless entries made on the DATEC System Evaluation Worksheets by the tech controllers and also Hardware Log entries which document use of this mode. The examples chosen in this instance involves test of the MAC unit at Site Sibyl which did not respond properly during the Normal Scan mode at the start of operations on 24 June. The DATEC System Evaluation Worksheets and Logbook entries indicating this are shown on pages 337, 338 and 339.

PROCEDURE	DATE	TIME
<p><u>Reciprocal Path Problem</u></p> <p>N1. Insert 10dB of attenuation between equalizer and IF in the A and B receivers at both HUA and SBL. <i>(Accomplished by introducing 10dB of attenuation in both TX and RX A waveguides at SIBYL)</i> <u>Transmit Antenna Only at Sibyl</u></p> <p>N2. Insert 10dB of attenuation between equalizer and IF in the A and B receivers at HUA and the B receiver only at SBL.</p> <p>N3. Restore equipment to baseline configuration</p> <p><i>Requested to lock on B TX @ HUA.</i></p> <p>CONDUCTED BY <u>C. L. Christies</u> 6-14-77</p> <p>OBSERVED BY _____</p>	6-14-77	1047

DATEC SYSTEM EVALUATION WORKSHEET

Page 3 14 June 77

OBSERVANCE (key points only)	PRINTOUT REF (ATTACH)	DATE	TIME
All systems green ./cs		6/14	1033
Degraded RSLs at SBL on both radios... Request maint switch to "B" Tx at HUA./cs	9/14 JUNE 77		1049
RSLs at HUA are also low... Fade seems independent of TXs... HUA going back to "A" Tx../cs	10/14 JUNE 77		1052
PROBLEM DUE TO FAST FADING IN BOTH DIRECTIONS LONG DURATION			1053
Request maint look into problem of low RSL... they advise that SBL was aligning both antennas at the same time.. request that they leave the antennas alone. ./cs	10/14 JUNE 77		1054
Problem cleared .			1102
Problem isolated to antenna alignment at SBL.			
Displays deemed most useful...			
<p>1) LS. page 1</p> <p>2) LP page 1 (MI was useful for fast update of RSLs)</p>			
<p>TECH CONTROLLER <u><i>R</i></u></p> <p>OBSERVED BY <u><i>CMS</i></u></p>			

#9 14 June 77

IO-006

		LINK STATUS		TIME 165/1133:15	
	TI-4000.....	RADIO.....	
		HUA	SBL	HUA	SBL
ALARM	SW MAJOR	.	.	TX PROB	.
	SW MINOR	.	.	RX PROB	.
	MAJOR	.	.		.
STATUS	TX IN SVC	A	A	TX IN SVC	A
	RX IN SVC	A	A	RX IN SVC	A
	MAINT	.	.	MAINT	.
PARAMETER	FER	<1.0E-7	<1.0E-7	RX SQUELCH	.
	CRFRM	.	.	RSL MARGIN	34.775 . 37.174
	BER COR	NO DATA	NO DATA	EYE MARGIN	13.831 . 12.334
				EYE AMPL	-8.8065 . -8.9355
				EYE HITS	0.0 . 0.0
				DER BER	3.4E-14 . 3.5E-13

PAGE 1

MAS

		LINK STATUS		TIME 165/1048:43	
	TI-4000.....	RADIO.....	
		HUA	SBL	HUA	SBL
ALARM	SW MAJOR	.	.	TX PROB	.
	SW MINOR	.	.	RX PROB	.
	MAJOR	.	.		.
STATUS	TX IN SVC	A	A	TX IN SVC	A
	RX IN SVC	A	A	RX IN SVC	A
	MAINT	.	.	MAINT	.
PARAMETER	FER	<1.0E-7	<1.0E-7	RX SQUELCH	.
	CRFRM	.	.	RSL MARGIN	30.889 . 27.455 A
	BER COR	NO DATA	NO DATA	EYE MARGIN	13.597 . 12.233
				EYE AMPL	-8.8065 . -8.9677
				EYE HITS	0.0 . 0.0
				DER BER	1.2E-13 . 7.3E-13

PAGE 1

BEST AVAILABLE COPY

BEST AVAILABLE COPY

#10 14 June 77

IQ-005

		LINK PERFORMANCE ASSESSMENT - RADIOS						TIME 165/1049:47		
		LAST	LAST 24 HR			LAST 30 DAYS		LAST 30 MTHS		
		SCAN	MEAN	MEAN	DEV	MEAN	DEV	MEAN	DEV	
HUA	RSLMAR	30.889	30.843	30.102	1.0384	27.695	6.6582	-----	-----	DB
A	EYEMAR	13.597	13.467	12.877	1.0429	11.058	3.4363	-----	-----	DB
	RSLAVL	1.0000	1.0000	1.0000	-----	.94172	-----	-----	-----	RATE
	EYEAVL	1.0000	1.0000	1.0000	-----	.93539	-----	-----	-----	RATE
	EYEHIT	0.0	0.0	5.2767	17.098	18.384	46.963	-----	-----	/SC
HUA	RSLMAR	28.058	30.094	25.750	7.3045	29.804	2.3211	-----	-----	DB
B	EYEMAR	5.9534	5.9534	6.6790	3.1434	7.7781	2.8328	-----	-----	DB
	RSLAVL	1.0000	1.0000	0.9966	-----	0.9938	-----	-----	-----	RATE
	EYEAVL	1.0000	1.0000	1.0000	-----	0.9955	-----	-----	-----	RATE
	EYEHIT	0.0	0.0	8.2610	21.003	4.0603	4.8525	-----	-----	/SC
SBL	RSLMAR	27.455	34.232	38.813	1.3072	38.153	1.3333	-----	-----	DB
A	EYEMAR	12.233	13.281	13.459	.35297	13.175	.53384	-----	-----	DB
	RSLAVL	1.0000	1.0000	1.0000	-----	1.0000	-----	-----	-----	RATE
	EYEAVL	1.0000	1.0000	1.0000	-----	0.9985	-----	-----	-----	RATE
	EYEHIT	0.0	0.0	16.238	51.564	2.3326	3.5727	-----	-----	/SC
SBL	RSLMAR	24.083	31.252	34.067	.85813	33.564	1.3180	-----	-----	DB
B	EYEMAR	12.800	12.800	13.396	.33560	12.925	1.1839	-----	-----	DB
	RSLAVL	1.0000	1.0000	1.0000	-----	1.0000	-----	-----	-----	RATE
	EYEAVL	1.0000	1.0000	1.0000	-----	0.9984	-----	-----	-----	RATE
	EYEHIT	0.0	0.0	0.3817	.23112	.77622	2.4187	-----	-----	/SC

MAC-1-01-02

		LINK PERFORMANCE ASSESSMENT - RADIOS						TIME 165/1051:25		
		LAST	LAST 24 HR			LAST 30 DAYS		LAST 30 MTHS		
		SCAN	MEAN	MEAN	DEV	MEAN	DEV	MEAN	DEV	
HUA	RSLMAR	21.109	30.843	30.102	1.0384	27.695	6.6582	-----	-----	DB
A	EYEMAR	13.597	13.467	12.877	1.0429	11.058	3.4363	-----	-----	DB
	RSLAVL	1.0000	1.0000	1.0000	-----	.94172	-----	-----	-----	RATE
	EYEAVL	1.0000	1.0000	1.0000	-----	.93539	-----	-----	-----	RATE
	EYEHIT	0.0	0.0	5.2767	17.098	18.384	46.963	-----	-----	/SC
HUA	RSLMAR	18.458	30.094	25.750	7.3045	29.804	2.3211	-----	-----	DB
B	EYEMAR	5.9534	5.9534	6.6790	3.1434	7.7781	2.8328	-----	-----	DB
	RSLAVL	1.0000	1.0000	0.9966	-----	0.9938	-----	-----	-----	RATE
	EYEAVL	1.0000	1.0000	1.0000	-----	0.9955	-----	-----	-----	RATE
	EYEHIT	0.0	0.0	8.2610	21.003	4.0603	4.8525	-----	-----	/SC
SBL	RSLMAR	27.455	34.232	38.813	1.3072	38.153	1.3333	-----	-----	DB
A	EYEMAR	10.809	12.804	13.459	.35297	13.175	.53384	-----	-----	DB
	RSLAVL	1.0000	1.0000	1.0000	-----	1.0000	-----	-----	-----	RATE
	EYEAVL	1.0000	1.0000	1.0000	-----	0.9985	-----	-----	-----	RATE
	EYEHIT	0.0	0.0	16.238	51.564	2.3326	3.5727	-----	-----	/SC
SBL	RSLMAR	24.083	31.252	34.067	.85813	33.564	1.3180	-----	-----	DB
	EYEMAR	12.800	12.800	13.396	.33560	12.925	1.1839	-----	-----	DB
	RSLAVL	1.0000	1.0000	1.0000	-----	1.0000	-----	-----	-----	RATE
	EYEAVL	1.0000	1.0000	1.0000	-----	0.9984	-----	-----	-----	RATE
	EYEHIT	0.0	0.0	0.3817	.23112	.77622	2.4187	-----	-----	/SC

PROCEDURE	DATE	TIME
U1. Install the Frame Bit Error Generator (FBEG) between the radio and T1-4000 in the RX base-band input line at SEL.	6-8-77	
U2. With the selector switch of the FBEG set to NARROW, momentarily depress the pushbutton switch several times (3-5). Repeat this operation at a rate of approximately once every 5 minutes. Record the time when each operation is performed.	6-8-77	
Perturbation No. 1		0938
" " 2		0943
" " 3		0947
" " 4		0952
" " 5		0958
" " 6		1010
" " 7		1018
" " 8		1025
" " 9		1030
" " 10		1033
" " 11		1036
" " 12		1038
U3. When test is completed, restore equipment to baseline configuration.	6-8-77	
" " 13		1041
" " 14		1045
" " 15		1048
CONDUCTED BY <u>P. L. Christy</u> 6-8-77		
OBSERVED BY _____		

DATEC SYSTEM EVALUATION WORKSHEET 8 June 77 Pg # 1

OBSERVANCE (key points only)	PRINTOUT REF (ATTACH)	DATE	TIME
Starting 8 June 77, with systems green, and data attached...///RR	1-4/8 June 77	6/8	0910
RT display shows Amber in-service for the MUX at SBL...Isolating problem ATT...////RR	5/8 June 77	6/8	0940
Link Status display shows FER Amber and BER COR Red at SBL.../PH	5/8 June 77 6/8 June 77	6/8	0942
After accessing the system statistics for SBL. found RSL Margin droppped 5 db, Eye margin dropped 1 db over the last hour..../PH	7/8 June 77	6/8	0950
Mux amber cleared and TLWB1 at SBL in amber att, Still trying to isolate pblm.../ph	8/8 June 77	6/8	1000
Still trying to isolate cause of RSL and Eye Margin drop..Watching RSL/Eye data on Monitor Immediate, slowly dropping.../ph		6/8	1030
Both TL-4000 and TLWB1 alarms have cleared off the system overview, but FER is still high and listed in the Amber zone on the Link Status display, also the BER COR is still in the Red zone. Suspect problem is at SBL but have not isoltaed as yet./ph	9/8 June 77	6/8	1045
Requested SRL Maint switch Mux to the "B" rcvr. This cleared the Amber and Red off the SBL Mux and the Link Status Display./ph		6/8	1050
SRL Changed out Rcv unit card on the TL-4000 Mux and Switched back to the "a" mux./ph		6/8	1055
Problem cleared and logged as a bad RCV Card in the TL-4000 Mux at SBL, replaced.../ph		6/8	1105
<p>TECH CONTROLLER _____</p> <p>OBSERVED BY _____</p>			

#1 8 June 77

10-007			SYSTEM OVERVIEW	TIME 15070921:37
RADIO A	HUA	SBL		
B	.	.		
MX SW	.	.		
A	.	.		
B	.	.		
CY144	.	.		
	.	.		
	.	.		
TIWBI	.	.		
	.	.		
TELEMETRY		
SITE	:	:		

AS-2			LINK STATUS	TIME 15070922:34
NO RESPONSE.		TI-4000.....RADIO.....
ALARM	SW MAJOR		HUA	SBL
	SW MINOR	.		
	MAJOR	.		
STATUS	TX IN SVC	A	A	
	RX IN SVC	A	A	
	MAINT	.	.	
PARAMETER	FER	<1.0E-7	<1.0E-7	
	CRFRM	.	.	
	BER COR	NO DATA	.NO DATA	
				TX PROB
				RX PROB
				TX IN SVC
				RX IN SVC
				MAINT
				RX SQUELCH
				RSL MARGIN 34.133 . 39.500
				EYE MARGIN 11.562 . 14.660
				EYE AMPL -8.8065 . -8.9677
				EYE HITS 0.0 . 0.0
				DER BER 1.7E-12 . 2.5E-14
				PAGE 1

#2 8 June 77

LINK STATUS

TIME 150/0924:14

.....CY-104.....

.....TIMBI.....

ALARM	SERVICE	HUA	SBL	OFFICE	HUA	SBL
	REMOTE
STATUS	MAINT	.	.	MAINT	.	.
PARAMETER	CHANNEL	.	.	FER <1.0E-6	.	<1.0E-6
		.	.	REFRAME	.	.
SITE	ENTRY	.	.			
ALARMS	FIRE	.	.			
	AC PWR	.	.			
	BATTERY	.	.			
	W.A. PR	.	.			
	W.G. HV	.	.			
	FL(XD)	.	.			

PAGE 2

IQ-005

LINK PERFORMANCE ASSESSMENT - RADIOS

TIME 150/0925:59

		LAST SCAN	LAST HR MEAN	LAST 24 HR MEAN	LAST 24 HR DEV	LAST 30 DAYS MEAN	LAST 30 DAYS DEV	LAST 30 MTHS MEAN	LAST 30 MTHS DEV	
HUA	RSLMAR	34.133	2.9833	6.7219	11.491	29.652	.21836	-----	-----	DB
A	EYEMAR	11.562	-7.2484	1.6522	6.7311	10.989	2.3534	-----	-----	DB
	RSLAVL	1.0000	.20000	.42642	-----	1.0000	-----	-----	-----	RATE
	EYEAVL	1.0000	.25000	.43066	-----	1.0000	-----	-----	-----	RATE
	EYEHIT	0.0	227.56	165.38	115.41	.04112	.04319	-----	-----	/SC
HUA	RSLMAR	34.713	34.459	32.274	1.9129	31.234	2.0800	-----	-----	DB
B	EYEMAR	10.462	10.462	10.219	2.2531	5.5974	2.3209	-----	-----	DB
	RSLAVL	1.0000	1.0000	.99245	-----	.98505	-----	-----	-----	RATE
	EYEAVL	1.0000	1.0000	1.0000	-----	0.9971	-----	-----	-----	RATE
	EYEHIT	0.0	0.0	2.6006	11.336	4.5383	5.4634	-----	-----	/SC
SBL	RSLMAR	39.500	40.127	33.716	1.0960	39.237	1.2267	-----	-----	DB
A	EYEMAR	14.660	14.629	13.432	.22425	12.611	.51716	-----	-----	DB
	RSLAVL	1.0000	1.0000	1.0000	-----	1.0000	-----	-----	-----	RATE
	EYEAVL	1.0000	1.0000	1.0000	-----	1.0000	-----	-----	-----	RATE
	EYEHIT	0.0	0.0	.01713	.07455	3.7936	4.1931	-----	-----	/SC
SBL	RSLMAR	33.364	33.300	33.591	.00691	34.973	.73836	-----	-----	DB
B	EYEMAR	14.421	14.421	13.434	.20247	12.059	1.6250	-----	-----	DB
	RSLAVL	1.0000	1.0000	1.0000	-----	1.0000	-----	-----	-----	RATE
	EYEAVL	1.0000	1.0000	1.0000	-----	0.9941	-----	-----	-----	RATE
	EYEHIT	0.0	0.0	0.0	0.0	2.1079	3.6463	-----	-----	/SC

04 14-1-11-10A04

0000AC-1-31-06A 0

#3 8 June 77

MAC-1-07-12

LINK PERFORMANCE ASSESSMENT - RADIOS

TIME 159/0928:51

	LAST SCAN	LAST HR MEAN	LAST 24 HR MEAN	LAST 24 HR DEV	LAST 30 DAYS MEAN	LAST 30 DAYS DEV	LAST 30 MTHS MEAN	LAST 30 MTHS DEV	
HUA EYEVOL	-3.7900	-6.0322	-5.0005	.72816	-3.9761	.20880	-----	-----	VLTS
A RXSQH	0.0	0.0	5.0000	-----	1.0000	-----	-----	-----	RTE
H EYEVOL	-4.0200	-4.0200	-4.0490	.21777	-4.4673	.22405	-----	-----	VLTS
B RXSQH	0.0	0.0	0.0	-----	11.000	-----	-----	-----	RTE
HUA LNKAVL	1.0000	1.0000	1.0000	-----	0.9986	-----	-----	-----	RTE
SBL EYEVOL	-3.6500	-3.6525	-3.7547	.02505	-3.8295	.04657	-----	-----	VLTS
A RXSQH	0.0	0.0	0.0	-----	11.000	-----	-----	-----	RTE
SBL EYEVOL	-3.6700	-3.6700	-3.7544	.01766	-3.9836	.14636	-----	-----	VLTS
B RXSQH	0.0	0.0	0.0	-----	6.0000	-----	-----	-----	RTE
SBL LNKAVL	1.0000	1.0000	1.0000	-----	1.0000	-----	-----	-----	RTE

MAS

LINK PERFORMANCE ASSESSMENT - T1-4000

TIME 159/0930:07

	LAST SCAN	LAST HR MEAN	LAST 24 HR MEAN	LAST 24 HR DEV	LAST 30 DAYS MEAN	LAST 30 DAYS DEV	LAST 30 MTHS MEAN	LAST 30 MTHS DEV	
HUA FER	1.0E-15	7.3E-6	1.3E-6	-----	1.8E-10	-----	-----	-----	RTE
A FERA VL	1.0000	1.0000	1.0000	-----	1.0000	-----	-----	-----	RTE
CRFRM	0.0	4.0000	7.0000	-----	1.5000	.86603	-----	-----	RTE
CR/SQH	0.0	0.0	1.0000	-----	0.0	-----	-----	-----	RTE
CR/HIT	0.0	2.0000	6.0000	-----	0.0	-----	-----	-----	RTE
HUA FER	1.0E-15	6.7E-17	1.4E-18	-----	-----	-----	-----	-----	RTE
B FERA VL	1.0000	1.0000	1.0000	-----	-----	-----	-----	-----	RTE
CRFRM	0.0	0.0	2.0000	-----	3.5000	2.9580	-----	-----	RTE
CR/SQH	0.0	0.0	1.0000	-----	0.0	-----	-----	-----	RTE
CR/HIT	0.0	0.0	1.0000	-----	0.0	-----	-----	-----	RTE
SBL FER	8.8E-8	8.8E-9	3.0E-8	-----	1.3E-7	-----	-----	-----	RTE
A FERA VL	1.0000	1.0000	1.0000	-----	1.0000	-----	-----	-----	RTE
CRFRM	0.0	0.0	0.0	-----	2.5000	2.2913	-----	-----	RTE
CR/SQH	0.0	0.0	0.0	-----	4.0000	-----	-----	-----	RTE
CR/HIT	0.0	0.0	0.0	-----	5.0000	-----	-----	-----	RTE
SBL FER	5.2E-10	1.7E-11	3.9E-6	-----	-----	-----	-----	-----	RTE
B FERA VL	1.0000	1.0000	1.0000	-----	-----	-----	-----	-----	RTE
CRFRM	0.0	0.0	0.0	-----	1.7500	1.4790	-----	-----	RTE
CR/SQH	0.0	0.0	0.0	-----	3.0000	-----	-----	-----	RTE
CR/HIT	0.0	0.0	0.0	-----	3.0000	-----	-----	-----	RTE

#4 8 JUNE 77

MAS

LINK PERFORMANCE ASSESSMENT - TIWBI										TIME 159/0931:17	
		LAST SCAN	LAST HR	LAST 24 HR	LAST 30 DAYS	LAST 30 DAYS	LAST 30 MTHS	LAST 30 MTHS			
		MEAN	MEAN	DEV	MEAN	DEV	MEAN	DEV			
HUA	FER	1.2E-14	8.9E-6	3.8E-6	-----	3.5E-10	-----	-----	-----	-----	RTE
	RFRM	0.0	5.0000	3.0000	-----	6.0000	4.7434	-----	-----	-----	RTE
SR	FER	1.2E-14	2.8E-15	4.2E-15	-----	3.2E-6	-----	-----	-----	-----	RTE
	RFRM	0.0	0.0	5.0000	-----	3.5000	3.2016	-----	-----	-----	RTE

IQ-008

MAINTENANCE VOLTAGES - HJA										TIME 159/0932:22	
NO.	NAME	VOLTS	C	RH	AH	CG	AL	RL	MEAN	DEV	INITIAL DATE
01	TIWBI+15	15.5	G	16.5	15.7	15.0	14.2	13.5	15.5	.037	153/0907
02	TIWBI+12	12.4	G	13.2	12.6	12.0	11.4	10.8	12.4	.019	153/0907
03	T14000+5	4.95	G	5.50	5.25	5.00	4.75	4.50	4.94	.012	153/0907
04	T14000-6	-6.08	G	-5.40	-5.70	-6.00	-6.30	-6.60	-6.08	0	153/0907
05	RADIO+24	23.9	G	26.4	25.2	24.0	22.8	21.6	23.9	.030	153/0907
06	RADIO-20	-19.9	G	-18.0	-19.0	-20.0	-21.0	-22.0	-19.9	.005	153/0907

MA 3-01-06

MAINTENANCE VOLTAGES - SBL										TIME 159/0933:28	
NO.	NAME	VOLTS	C	RH	AH	CG	AL	RL	MEAN	DEV	INITIAL DATE
01	TIWBI+15	15.2	G	16.5	15.7	15.0	14.2	13.5	15.1	.016	153/0911
02	TIWBI+12	12.3	G	13.2	12.6	12.0	11.4	10.8	12.3	0	153/0911
03	T14000+5	4.95	G	5.50	5.25	5.00	4.75	4.50	4.95	0	153/0911
04	T14000-6	-6.05	G	-5.40	-5.70	-6.00	-6.30	-6.60	-6.04	.006	153/0911
05	RADIO+24	24.1	G	26.4	25.2	24.0	22.8	21.6	24.1	.014	153/0911
06	RADIO-20	-20.1	G	-18.0	-19.0	-20.0	-21.0	-22.0	-20.1	1.6E	153/0911

5/8

MAC-1-07-12

SYSTEM OVERVIEW

TIME 150/0941:56

	HUA	SBL
RADIO A	.	.
B	.	.
MUX SW	.	.
A	.	>IA.
B	.	.
CY104	.	.
	.	.
	.	.
	.	.
	.	.
	.	.
TIWBI	.	.

TELEMETRY.

SITE	:	:	:
MAS	:	:	:

LINK STATUS
PI-4000.....

	HUA	SBL
--	-----	-----

TIME 150/0942:50
RADIO.....

	HUA	SBL
--	-----	-----

ALARM	SW MAJOR		.
	SW MINOR		.
	MAJOR		.
STATUS	TX IN SVC	A	A
	RX IN SVC	A	A
	MAINT		.
PARAMETER	FER	<1.0E-7	1.3E-7 A
	CRFRM		.
	BER COR	NO DATA	6.5459 R

TX PROB		.
RX PROB		.
		.
TX IN SVC	A	A
RX IN SVC	A	A
MAINT		.
RX SQUELCH		.
RSL MARGIN	29.615	37.600
EYE MARGIN	12.687	14.182
EYE AMPL	-3.8065	-3.0677
EYE HITS	0.0	0.0
DER BER	4.0E-13	5.1E-14

PAGE 1

6/8

IQ-008		LINK PERFORMANCE ASSESSMENT - T1-4000						TIME 150/0944:47		
		LAST SCAN	LAST HR MEAN	LAST 24 HR MEAN	LAST 30 DAYS DEV	LAST 30 DAYS MEAN	LAST 30 MTHS DEV	LAST 30 MTHS MEAN	LAST 30 MTHS DEV	
H	FER	1.0E-15	7.3E-6	1.3E-6	-----	1.8E-10	-----	-----	-----	RTE
A	FERAVL	1.0000	1.0000	1.0000	-----	1.0000	-----	-----	-----	RTE
	CRFRM	0.0	4.0000	7.0000	-----	1.5000	.86603	-----	-----	RTE
	CR/SQH	0.0	0.0	1.0000	-----	0.0	-----	-----	-----	RTE
	CR/HIT	0.0	2.0000	6.0000	-----	0.0	-----	-----	-----	RTE
HJA	FER	1.0E-15	6.7E-17	1.4E-18	-----	-----	-----	-----	-----	RTE
B	FERAVL	1.0000	1.0000	1.0000	-----	-----	-----	-----	-----	RTE
	CRFRM	0.0	0.0	2.0000	-----	3.5000	2.9580	-----	-----	RTE
	CR/SQH	0.0	0.0	1.0000	-----	0.0	-----	-----	-----	RTE
	CR/HIT	0.0	0.0	1.0000	-----	0.0	-----	-----	-----	RTE
SBL	FER	1.8E-7	1.8E-8	3.0E-8	-----	1.3E-7	-----	-----	-----	RTE
A	FERAVL	1.0000	1.0000	1.0000	-----	1.0000	-----	-----	-----	RTE
	CRFRM	0.0	0.0	0.0	-----	2.5000	2.2913	-----	-----	RTE
	CR/SQH	0.0	0.0	0.0	-----	4.0000	-----	-----	-----	RTE
	CR/HIT	0.0	0.0	0.0	-----	5.0000	-----	-----	-----	RTE
SBL	FER	5.2E-10	1.7E-11	3.9E-6	-----	-----	-----	-----	-----	RTE
B	FERAVL	1.0000	1.0000	1.0000	-----	-----	-----	-----	-----	RTE
	CRFRM	0.0	0.0	0.0	-----	1.7500	1.4790	-----	-----	RTE
	CR/SQH	0.0	0.0	0.0	-----	3.0000	-----	-----	-----	RTE
	CR/HIT	0.0	0.0	0.0	-----	3.0000	-----	-----	-----	RTE

7/8

NC, AC, SS, SBL

PARAMETER ?1

TI	PERIOD ?H			
01	37.700	17	OMIT	33 OMIT
02	37.600	18	OMIT	34 OMIT
03	38.100	19	OMIT	
04	39.500	20	OMIT	
05	39.875	21	OMIT	
06	39.250	22	OMIT	
07	39.500	23	OMIT	
08	39.875	24	OMIT	
09	41.667	25	OMIT	
10	41.222	26	OMIT	
11	OMIT	27	OMIT	
12	OMIT	28	OMIT	
13	OMIT	29	OMIT	
14	OMIT	30	OMIT	
15	OMIT	31	OMIT	
16	OMIT	32	OMIT	

TIME PERIOD ?

NC, AC, SS, SBL

PARAMETER ?9

TIME PERIOD ?H			
01	13.831	17	OMIT
02	14.182	18	OMIT
03	14.660	19	OMIT
04	14.542	20	OMIT
05	14.421	21	OMIT
06	14.895	22	OMIT
07	OMIT	23	OMIT
08	OMIT	24	OMIT
09	OMIT	25	OMIT
10	OMIT	26	OMIT
11	OMIT	27	OMIT
12	OMIT	28	OMIT
13	OMIT	29	OMIT
14	OMIT	30	OMIT
15	OMIT	31	OMIT
16	OMIT	32	OMIT

TIME PERIOD ?

9/8

MAS

LINK PERFORMANCE ASSESSMENT - TIWBI							TIME 159/1005:51	
	LAST SCAN	LAST HR MEAN	LAST 24 HR MEAN	DEV	LAST 30 DAYS MEAN	DEV	LAST 30 MTHS MEAN	DEV
HUA FER	1.2E-14	8.9E-6	3.8E-6	-----	3.5E-10	-----	-----	-----
RFRM	0.0	5.0000	3.0000	-----	6.0000	4.7434	-----	-----
SBL FER	2.2E-6	1.1E-7	4.2E-15	-----	3.2E-6	-----	-----	-----
RFRM	0.0	0.0	5.0000	-----	3.5000	3.2016	-----	-----

NC, AC, SS, SBL

PARAMETER ?23

TIME PERIOD ?H			
01	2.0800	17	OMIT
02	1.0200	18	OMIT
03	1.2E-8	19	OMIT
04	1.2E-8	20	OMIT
05	1.2E-8	21	OMIT
06	1.2E-8	22	OMIT
07	1.2E-8	23	OMIT
08	1.2E-8	24	OMIT
09	1.2E-8	25	OMIT
10	1.2E-8	26	OMIT
11	1.2E-8	27	OMIT
12	OMIT	28	OMIT
13	OMIT	29	OMIT
14	OMIT	30	OMIT
15	OMIT	31	OMIT
16	OMIT	32	OMIT
		33	OMIT
		34	OMIT

TIME PERIOD ?

OBSERVANCE (key points only)	PRINTOUT REF (ATTACH)	DATE	TIME
Starting new day, with a problem with the MAC at SRL..Honeywell is working on it..Seems we getting constant 0 voltage readings from their MAC.. This was found by using the MAC Self Test..//RR	//RR	6/24	0745
Honeywell advs that they have to go to SRL, and swap out the MAC with the one from here at HUA. they will than bring the one from SRL here to attempt to repair..Appears we will conduct no testing on the system, till at least late this afternoon...//RR			0825

TECH CONTROLLER _____

OBSERVED BY _____



Handwritten signature in cursive script, appearing to be 'R. P.', written over two horizontal lines.

DATE 5-2-77

TEST NO. _____
DEV. NO. _____
PAGE _____ OF _____

1

LOG INITIATED 5-2-77 1300 HRS

1.) 6-6-77, ^{1300 HRS} — EPVT counters for T1-4000 FER (A&B) not resetting to zero — they reset to +0.5 volt. Could not find problem immediately — since it does not affect the test scenarios, ~~nothing~~ problem will be worked on part time basis. c/c.

6-14-77, 0940 HRS.
2.) BEM (A) HITS observed to change erratically when monitored in MI scan. Problem was isolated to the No. 2 scanner card for channels 10-19 by card substitution. The No. 4 scanner card ^(which is unused) was interchanged with the No. 2 card & problem was resolved. The No. 2 (bad) card will be brought down from SIBYL for problem investigation on the next trip up there. c/c.

3.) 6-16-77, 1100.
Changed strapping in EPVT Command Card to 3 1/2 minutes (See HUA Hardware Log ⁶⁻¹⁵⁻⁷⁷ for reason) c/c.

4.) 6-24-77, 0815
Was running long-term RSL during previous night — when we tried to correlate statistics file with recorder traces, it was noted that for the last 8-10 hrs, both ~~HUA~~ A & B RSL @ SBL were reading -3 dB RSL MARGIN. A MAC self test at SBL failed. Unit returned all zeros for self test voltage measurements. TJC took MAC from HUA to SBL in order to swap them out & bring MAC previously @ SBL to HUA so that we ³³⁸ could isolate the fault.

DATE 6-24-77

TEST NO. _____
DEV. NO. _____
PAGE _____ OF _____

6-24-77 entry cont'd: —
By the time TJC reached SBL, the MAC there was operating. He was told by site personnel that when they first entered the van it was very warm. (Air conditioner had been turned off the previous evening). Since the unit now passed local self test, the MAC originally @ SBL was left there since it would have meant re-strapping to swap the two MACs. etc.

5) 7-21-77 1600 HRS — Made changes to babbling in both vans to switch over to ARSA radio. Made same changes to BAC & BEM that were made @ HVA. (see HVA HADR LOG - entry 9, page 3) etc.

6.1.6 The DATEC Capability to Accomplish the Proposed CPMAS Functions, to Provide this Information in a Timely Manner to Achieve and Maintain the Performance Objectives of the FKV Type System

The validation tests of Appendices A through H of the Field Test Plan/Procedures document verified that all CPMAS functions were performed by the DATEC system as proposed. These functions were listed in Paragraph 6.1.1 of this section.

DATEC, being a passive monitoring system, cannot in itself achieve the performance objectives of an FKV type system. However, as was demonstrated throughout the System Simulation Scenarios, it is an effective tool in maintaining those objectives once obtained. The primary performance objective for the digital transmission system at Ft. Huachuca (which typifies the FKV system) is a bit error rate (BER) of $<1 \times 10^{-7}$. BER is derived by the BEM by processing signal-to-noise relationship at the baseband between the radio and high level MUX. Although not directly measured, this derived BER correlates well with BER measured by a BER tester. This was verified during BEM calibration operations required for site data base generation and later following the System Simulation Scenarios with the AN/FRC-162 radio before starting tests with the DR8A radio. This data is presented in Paragraph 6.1.3 of this section. This data shows correlation for BER $>1 \times 10^{-7}$. Correlation through two more orders of magnitude (1×10^{-9}) was demonstrated during final developmental testing of the BEM in-plant. This data may also be found in Paragraph 6.1.3 Derivation of BER values below 10^{-9} was obtained using the somewhat involved procedure presented in great detail in Section 3 of this report.

BEM derived BER is especially useful in early recognition of degrading bit error rate performance at the T1-4000 level because, on a single scan basis, error rates can be detected which are much lower than that which can be measured by monitoring the T1-4000 frame bit errors. With an EPUT sample time of 3-1/2 minutes for frame errors, the resolution (or lowest FER measurable) for a single scan is 5×10^{-8} . However, the resolution improves when this parameter is trended over a period of time. For example, a one hour T1-4000 FER sample has a threshold of approximately 3×10^{-9} . On a long-term basis, then, the FER parameter can be used to detect degradation of BER toward the 10^{-7} performance objective provided the rate of degradation is gradual.

Radio link problems, which if allowed to deteriorate, could cause system performance objectives to degrade beyond acceptable limits, can be detected at an early stage by observing the parameter, RSL Margin. Data taken during BEM calibration (previously mentioned in this section) indicated that at the PCM threshold,

which was at least 35 dB below the mean RSL for the Ft. Huachuca-Sibyl link with the AN/FRC-162 in-service, the system BER was still less than 10^{-8} . Problems involving degradation of RSL were readily identified by the technical controllers during the System Simulation Scenarios well before they reached the PCM threshold. Examples of the manner in which this parameter, RSL Margin, and the BEM derived BER were used to maintain the system performance objective follow. A clear illustration of the use of the T1-4000 parameter, FER, for this purpose does not exist because, as will be discussed in greater detail in subsequent paragraphs, the long-term trend analysis capabilities of DATEC were not utilized in this regard during field tests. The first example involves use of the BEM parameters Eye Margin and DER BER in a timely manner to resolve a developing problem before the 1×10^{-7} system BER objective was exceeded. As will be further discussed in Paragraph 6.1.14, the amber threshold for Eye Margin was changed to coincide with a DER BER of 1×10^{-9} . This was done subsequent to this scenario. The technical controller recognized the problem anyway, but the alarm flag made it more effective for later scenarios. This example, taken from an Appendix R scenario, 13 June 1977, RFI and Abnormal Interference, was previously used to illustrate a point in Paragraph 6.1.3. Reference should be made to the technical controller's comments and the display printouts.

Another good example of the use of Eye parameters to maintain good system operation is the Appendix L scenario conducted on 8 June 1977. (Refer to pages 242 through 248 in Paragraph 6.1.1). Note that the problem has been detected by Eye Margin and Hits while DER BER is still only about 10^{-9} . Note also that FER is still less than the threshold, 1×10^{-7} .

The last example illustrates use of the RSL parameter in a scenario (Appendix M, 14 June 1977) simulating a transmitter output power problem at Ft. Huachuca. In this example, the fault has been found and corrected before DER BER reached 10^{-12} .



6.1.7 The DATEC Capability to Facilitate CPMAS Procedures

CPMAS requirements address those measurements and data analysis tasks needed to support the digital communications system performance requirements. The monitoring system requirements and monitor point identification which form the baseline for the DATEC system have been discussed previously in this and other reports and will not be covered here. Instead, the emphasis will be focused on DATEC's ability to make easier, the CPMAS monitoring and measurement procedures.

The DATEC system was developed to function as a data measurement, analysis and reporting system which would aid the technical controller in assessing, correcting, and trending the performance of the digital transmission system under his control. More specifically, the DATEC system should be

PROCEDURE	DATE	TIME
<p>M1. With power off the radio and DATEC equipment at HUA, desolder the AGC B lead coming from the radio to the Analog Scanner at Analog Scanner TB1-18. Connect a jumper wire between TB1-13 and 18. Re apply power; put equipment into operation.</p> <p>M2. Using attenuator installed in transmitter waveguide at HUA, introduce attenuation at the approximate rate of 2dB every 5 minutes. Record the time as each dB of attenuation is introduced.</p> <p style="text-align: center;"> -1dB -2 -2dB -4 -3dB -6 -4dB -8 -5dB -10 -6dB -12 -7dB -14 -8dB -16 -9dB -18 -10dB -20 -11dB -22 -12dB -24 -13dB -26 -14dB -28 -15dB -30 -16dB -32 -17dB -34 -18dB -36 -19dB -38 -20dB -40 </p> <p>Requested to lock on B TX @ HUA @ 1027 Removed attenuation at that time. Switched back to A TX @ 1032.</p>	<p>6-14-77</p> 	<p>1016 1020 1024</p>
<p>M3. Restore equipment to baseline configuration.</p> <p>CONDUCTED BY <u>C. L. Christner</u> 6-14-77</p> <p>OBSERVED BY _____</p>		

DATEC SYSTEM EVALUATION WORKSHEET 14 June 77, Pg # 2

OBSERVANCE (key points only)	PRINTOUT REF (ATTACH)	DATE	TIME
All systems green.../cs		6/14	1015
Link Status indicates SBL's "A" radio recvr has gone amber, so has "B" radio recvr...cs	7/ 14 June 77		1020
Request maint go to "B" transmit radio at HUA ..cs	8/ 14 June 77		1027
SBL's RSL are good ..,Request maint check HUA's "A" Tx output power... it is OK.../cs			1030
Back on "A" radioTx at HUA...it is good... maint a dvise problem was MW amp in Tx.../cs			1032
<hr/>			
Problem was isolated to a bad Tx at HUA..			
Displays deemed useful are:			
1) LS page 1			
2) LP page 1			
TECH CONTROLLER			
OBSERVED BY			

7 14 June 77

	MAS	T1-4000.....		LINK STATUS	RADIO.....	
	HUA	SBL	HUA	SBL	HUA	SBL	HUA	SBL
ALARM	SW MAJOR	.			TX PROB	.		
	SW MINOR	.			RX PROB	.		
	MAJOR	.				.		
STATUS	TX IN SVC	A	A		TX IN SVC	A	A	
	RX IN SVC	A	A		RX IN SVC	A	A	
	MAINT	.	.		MAINT	.	.	
PARAMETER	FER	<1.0E-7	<1.0E-7		RX SQUELCH	.	.	
	CRFRM	.	.		RSL MARGIN	31.278	30.000 A	
	BER COR	NO DATA	NO DATA		EYE MARGIN	13.369	12.573	
					EYE AMPL	-3.8765	-3.9355	
					EYE HITS	0.0	0.0	
					DER BER	1.6E-13	4.7E-13	

PAGE 1

IQ-005

LINK PERFORMANCE ASSESSMENT - RADIOS										TIME 165/1026:12	
		LAST SCAN	LAST HR	LAST 24 HR	LAST 30 DAYS	LAST 30 DAYS	LAST 30 DAYS	LAST 30 DAYS	LAST 30 DAYS	LAST 30 DAYS	
			MEAN	MEAN	DEV	MEAN	DEV	MEAN	DEV		
HUA	RSLMAR	31.278	30.898	30.102	1.0334	27.695	6.6532				DB
A	EYEMAR	13.369	13.369	12.877	1.0429	11.058	3.4363				DB
	RSLAVL	1.0000	1.0000	1.0000		.94172					RATE
	EYEA VL	1.0000	1.0000	1.0000		.93537					RATE
	EYEHIT	0.0	0.0	5.2767	17.008	18.334	48.263				ZSC
HUA	RSLMAR	32.281	32.105	25.750	7.3045	29.804	2.3211				DB
B	EYEMAR	5.9534	5.9534	6.6790	3.1434	7.7781	2.8824				DB
	RSLAVL	1.0000	1.0000	0.9956		0.9933					RATE
	EYEA VL	1.0000	1.0000	1.0000		0.9955					RATE
	EYEHIT	0.0	0.0	3.2613	21.003	4.0648	4.8525				ZSC
SBL	RSLMAR	30.001	34.493	33.313	1.3072	38.158	1.3803				DB
A	EYEMAR	12.573	13.931	13.452	.85227	13.175	.50384				DB
	RSLAVL	1.0000	1.0000	1.0000		1.0000					RATE
	EYEA VL	1.0000	1.0000	1.0000		0.9995					RATE
	EYEHIT	0.0	0.0	16.238	51.564	2.0325	3.5727				ZSC
SBL	RSLMAR	27.545	31.668	34.767	.85813	23.564	1.3193				DB
B	EYEMAR	12.800	12.300	13.395	.83563	12.925	1.1809				DB
	RSLAVL	1.0000	1.0000	1.0000		1.0000					RATE
	EYEA VL	1.0000	1.0000	1.0000		0.9984					RATE
	EYEHIT	0.0	0.0	.13317	.23112	.71629	2.4187				ZSC

BEST AVAILABLE COPY

8 14 June 77

MAC-3-01-02

LINK STATUS
..... 11-4000

TIME 165/1430:04
..... RADIO

		HUA	SBL		HUA	SBL
ALARM	SW MAJOR	.	.	TX PROB	.	.
	SW MINOR	.	.	RX PROB	.	.
	MAJOR	.	.			
STATUS	TX IN SVC	A	A	TX IN SVC	B	A
	RX IN SVC	A	A	RX IN SVC	A	A
	MAINT	.	.	MAINT	.	.
PARAMETER	FERR	1.0E-7	<1.0E-7	RX SQUELCH	.	.
	CRFRM	.	.	RSL MARGIN	30.778	38.100
	BER COR	NO DATA	NO DATA	EYE MARGIN	13.369	12.459
				EYE AMPL	-3.8765	-3.9355
				EYE HITS	0.0	0.0
				DER BER	1.6E-13	5.5E-13

PAGE 1

MAC-3-01-02

LINK PERFORMANCE ASSESSMENT - RADIO

TIME 165/1431:10

		LAST SCAN	LAST HR MEAN	LAST 24 HR MEAN	LAST 24 HR DEV	LAST 30 DAYS MEAN	LAST 30 DAYS DEV	LAST 30 DAYS MEAN	LAST 30 DAYS DEV	
HUA	RSLMAR	30.778	30.831	30.102	1.0334	27.695	6.8502	30.778	6.8502	DB
A	EYEMAR	13.369	13.369	12.877	1.0429	11.053	3.4363	13.369	3.4363	DB
	RSLAVL	1.0000	1.0000	1.0000	-----	.94172	-----	1.0000	-----	RATE
	EYEAFL	1.0000	1.0000	1.0000	-----	.93539	-----	1.0000	-----	RATE
	EYEHIT	0.0	0.0	0.2767	17.096	19.234	44.263	0.0	-----	ZSC
HUA	RSLMAR	32.018	32.098	25.759	7.3545	29.894	2.3011	32.018	2.3011	DB
B	EYEMAR	5.9534	5.9534	6.6724	3.1434	7.7781	2.8028	5.9534	2.8028	DB
	RSLAVL	1.0000	1.0000	1.0000	-----	0.9933	-----	1.0000	-----	RATE
	EYEAFL	1.0000	1.0000	1.0000	-----	1.0000	-----	1.0000	-----	RATE
	EYEHIT	0.0	0.0	0.2613	21.003	4.0603	4.8525	0.0	-----	ZSC
SBL	RSLMAR	33.103	34.493	33.613	1.3072	33.151	1.3033	33.103	1.3033	DB
A	EYEMAR	12.459	13.441	13.459	.35297	13.175	.53364	12.459	.53364	DB
	RSLAVL	1.0000	1.0000	1.0000	-----	1.0000	-----	1.0000	-----	RATE
	EYEAFL	1.0000	1.0000	1.0000	-----	1.0000	-----	1.0000	-----	RATE
	EYEHIT	0.0	0.0	15.253	51.564	2.1326	3.8727	0.0	-----	ZSC
SBL	RSLMAR	35.503	31.660	34.867	.85813	30.564	1.3100	35.503	1.3100	DB
	EYEMAR	12.800	12.800	13.396	.33567	12.925	1.1849	12.800	1.1849	DB
	RSLAVL	1.0000	1.0000	1.0000	-----	1.0000	-----	1.0000	-----	RATE
	EYEAFL	1.0000	1.0000	1.0000	-----	1.0000	-----	1.0000	-----	RATE
	EYEHIT	0.0	0.0	1.0017	.23112	.77329	2.4100	0.0	-----	ZSC

BEST AVAILABLE COPY

evaluated by its ability to accomplish performance assessment, fault isolation and trend analysis of a digital transmission system for it is in the accomplishing of these objectives that the net worth of the system can be judged for making the CPMAS procedures easier.

The performance assessment task requires the technical controller to determine the operating communications system characteristics including some measure of system and equipment operating margin. Using only standard measuring equipment, the technical controller would be able to measure the receiver automatic gain control voltage and from that determine the received signal level and operating or fade margin. He would not be able to make any assessment of the digital multiplexer operating performance other than to verify that there are presently no alarm conditions. The DATEC system accomplishes performance assessment by measuring system and equipment performance indicators thereby making easier the technical controller's job. In addition to assuming the RSL measurement task already discussed, the DATEC system also gathers performance data relative to the quality of the received signal, and its operating margin, by analyzing the radio baseband signal for values of eye margin, eye amplitude, and derived system bit error rate. Multiplexer performance is measured by monitoring the frame error rate and resynchronization activity on both the high and low level multiplexer. Using this information the technical controller can function in the capacity of a nodal controller, one who is responsible for the proper operation of multiple sites, both manned and unmanned. The usefulness and effectiveness of this approach was demonstrated during the scenario evaluations wherein the technical controller looked first to the system overview display to notify him of degraded conditions within his nodal area. The fact that only two sites (one link) were involved in the testing in no way diminishes the observed effectiveness of the system overview display. Time after time as shown on the worksheets in Appendices U' (20 June), L (20 June), and R (21 June) the system overview was judged effective in alerting the technical controller to system performance degradations. Once alerted to a link problem the technical controller moved to the link status display where he was provided alarm, status and parameter information directly usable in determining the source of the problem. Once again, the technical controller worksheets attest to the usefulness of the link status displays in Appendices L (14 June), M (14 June), and DD (9 June).

There can be little doubt, then, that the DATEC system facilitates CPMAS procedures in performance assessment measurements by enabling the technical controller to function as a nodal controller thereby assuming the responsibility of accomplishing performance assessment for a number of sites.

DATEC SYSTEM EVALUATION WORKSHEET 20 June 77 Pg # 1



OBSERVANCE (key points only)	PRINTOUT REF (ATTACH)	DATE	TIME
Starting new day, with systems green, and data attached.////RR	1 1-4/20 June 77	6/20	0845
Overview display indicates the "A" mux at HUA is amber...Letting another scan go thru before doing anything...////RR	5/20 June 77		0846
Link status display indicates the problem with the "A" mux is FER....Requested maint switch HUA to the "B" recv mux.////RR	6/20 June 77		0850
On "B" mux, recv at HUA, and display indicates this is also bad....However, this could be old data so have to wait for another scan before we can decide if there is any problem with the "B" mux...////RR	7/20 June 77		0857
"B" mux has now cleared, and service appears to be restored....Advised maint to check the "A" mux, Recv at HUA.....////RR	8/20 June 77		0900
Problem isolated to bad Recv "A" mux at HUA.. maint advsd problem with the "Recv time base"... System back on the "A" mux ATT...////RR			0913
Displays used.....			
1. System overview			
2. Link status Pg #1			
Note: The length of time required to determine if the "B" mux was good (after putting it on line) was lengthy, due to the scanning sequence/time...////RR			
TECH CONTROLLER <u></u>			
OBSERVED BY <u>CM5</u>			

DATEC SYSTEM EVALUATION WORKSHEET 20 June 77, Pg # 3

OBSERVANCE (key points only)	PRINTOUT REF (ATTACH)	DATE	TIME
Systems Green...////RR		6/20	1030
Display shows amber on the TL4000 and TLWBI at HUA...//RR (Overview)	11/20 June 77		1059
Both above amber conditions cleared, and overview shows no problem...////RR			1103
Based on above, checked link status (suspected recvr squelch), and this showed the "B" recvr in service at HUA...////RR	12/20 June 77		1104
LP indicated "A" radio was good...no indication as to why the switch to "B" was made...////RR Also requested maint. switch the system back to the "A" Recvr...They advsd it would not swtch...//RR	13/20 June 77		1106
Requested maint at HUA check the "A" Rcvr..and they indicated they had a problem with it...//RR			1111
Maint advsd they had a noisy "A" Recvr...//RR all systems normled...////RR			1132
<hr/>			
Problem isolated to noisy "A " Recvr at HUA...			
Displays usefyl////			
1. Overview			
2. LP Pg # 1			
Comment: Page 14 to day indicates the Rx was bad ("A") at HUA fifteen minutes after the actual problem started. can't explain the long delay.../cs	14/20 June 77		
TECH CONTROLLER <u>CMS</u>			
OBSERVED BY <u>P</u>			

DATEC SYSTEM EVALUATION WORKSHEET

21 June 1977/pg #3

OBSERVANCE (key points only)	PRINTOUT REF (ATTACH)	DATE	TIME
systems green...//RR		6/21	1300
System overview show amber on the REC "A" mux and TLWBL..../ph	#5/21 June 1977		1310
Request maint switch from "A" to "B" rec mux at HUA....and check out the "A" mux for framing error tpls..../ph			1312
Maint advise that "A" mux is good, when we shifted to the "B" mux all amber conditions cleared...advised maint to switch to "A" mux. maint advise possible cause of framing errors was a clean-up team working in and around the mux may have jarred something..../ph			1315
SBL "B" radio in amber on system overview, reason unknown..asked SBL to check his radio,../ph	6/7/21 June 1977		1316
Link performance indicates both eye margins are low on SBL rec..../ph			1320
Requested that SBL check out for any interference on his rec.../ph			1325
Maintenance advises that he is send the interference on his transmitter, he switched to the "B" transmitt e r while he is working on the "A"...../ph			1328
Dis lays used: System overview Link Status Link performance (Most Help)			
TECH CONTROLLER 			
OBSERVED BY 			

DATEC SYSTEM EVALUATION WORKSHEET 14 June 77, Pg # 1

OBSERVANCE (key points only)	PRINTOUT REF (ATTACH)	DATE	TIME
All Sy stems are green and/or normal...//./cs Displays indicate the RSL margin at HUA is beginning to degrade...//RR	1-4/ 14 June 77	6/14	0741 0831
System at HUA switched to the "B" recvr..No indication as to why...//RR	5/14 June 77		0839
Attempted to manually switch the recv at HUA back to the "A" recvr...unable to do this...//RR			0845
Locked HUA Recv on the "B" recvr...Requested maint check out the "A" recvr..See RSL margin degraded, and also see the Eye margin on the "A " recvr degrading...//RR	5-6/14 June 77		0854
Maint advsd they had a bad IF int the "A" Recv.. The "A" recvr now back on line and fivers...//RR			0910
Problem resolved:::::Bad IF within the "A " Recvr at HUA...//RR			
Following displays were useful in tracing the problem.... 1....LS Pg # 1 2....LP Pg # 1			
NOTE: Displays indicating faulty Eye data on "A" ra dio at SEL...Turned over to maint to check the system...//RR			0925
NOTE: Honeywell advsd appears to be a bad relay card in the EPUT scanner at SEL.. They swapped with a spare...//RR/Eye hits clear, however now showing bad Eye Amplitude..Honeywell still checking ...//RR			0953
Problem cleared by Honeywell...//cs			1015
TECH CONTROLLER <u></u>			
OBSERVED BY <u>CMS</u>			

DATEC SYSTEM EVALUATION WORKSHEET 14 June 77, Pg # 2

OBSERVANCE (key points only)	PRINTOUT REF (ATTACH)	DATE	TIME
All systems green.../cs		6/14	1015
Link Status indicates SEL's "A" radio recvr has gone amber, so has "B" radio recvr...cs	7/ 14 June 77		1020
Request maint go to "B" transmit radio at HUA ..cs	8/ 14 June 77		1027
SEL's RSL are good ..,Request maint check HUA's "A" I Tx output power... it is OK.../cs			1030
Back on "A" radioTx at HUA...it is good... maint a dvise problem was MW amp in Tx.../cs			1032
<hr/> Problem was isolated to a bad Tx at HUA..			
Displays deemed useful are:			
1) LS page 1 2) LP page 1			
TECH CONTROLLER <u></u>			
OBSERVED BY <u>cms</u>			

DATEC SYSTEM EVALUATION WORKSHEET 9 June 77 Pg # 1

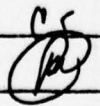
OBSERVANCE (key points only)	PRINTOUT REF (ATTACH)	DATE	TIME
Starting new day, with systems data atchd.//RF	1-4/9 June 77	6/9	0900
CRT display indicates Major Alarm, TLWB1 at HUA and SBL appear not to be passing traffic.//cs	5-/9 June 77		0918
Check link status of TLWB1 and get alarm indication, check maint voltages at HUA and SBL appear good.//cs	6/ 9 June		0925
Link SMI Status Now indicates bad recv on TLWB1 at HUA...SBL recv shows excellent.//cs	7/ 9June		0935
Link Performance assessment indicates good TL-4000,.. in house loopback on TLWB1 is good.//cs	8/ 9June 77		0938
Request loop back of SBL's TLWB1, Checks GOOD... Suspect bad recv channel in HUA's TL-4000 or bad transmit channel in SBL's TL-4000. Turn over in house problem to maintenance first.//cs			0942
Maintenance informs that there was a bad recv card in TL-4000, was replaced, framing error rate back to normal.//cs	9/ 9June 77		0951
Problem isolated to be bad TL-40000 RCV card. /cs			
TECH CONTROLLER _____ OBSERVED BY _____			

Next in the list of CPMAS requirements is the ability to perform fault isolation. This task is currently performed by the technical controller wherein he uses equipment alarms to isolate failures. This procedure limits the technical controller to addressing only those fault conditions which result in an equipment alarm and places the isolation of degraded equipment and system performance, with accompanying intermittent problems, beyond the reach of the technical controller using standard measuring equipment and techniques.

The DATEC system provides the technical controller with alarm information thereby enabling him to perform fault isolation within his nodal responsibility. It also provides him with parameter information thereby enhancing not only his fault isolating capability, but also providing him the ability to effectively execute degradation isolation. The usefulness and effectiveness of fault isolation was demonstrated throughout the system scenario evaluation. Appendices N, P and U, excerpts of which appear throughout this section, illustrate the technical controller utilization of the DATEC system in resolving system and equipment problems. An illustration of the effectiveness of identifying and correcting system degradations before they became system failures is shown in Appendix L (14 June) where technical controller corrective action was initiated prior to the point at which the degradation would have been identifiable as a system fault. The timely identification and resolution of system faults and degradations, as evidenced by the scenario results, serves to confirm the ability of the DATEC system to facilitate CPMAS procedures by making easier and more effective the technical controller's job of fault and degradation isolation.

The inclusion of trend analysis as a CPMAS requirement is to be viewed as an extension of the performance assessment function already discussed, for it is through long term trending of key performance assessment parameters that DATEC could make possible a reduction in manpower and the unmanning of sites. Looking first at the counterpart of trending in the field today, we see that while attempts have been made in the past to collect long term data, the data has often been regarded as highly suspect as to its validity and usefulness mainly because of the man in the loop which means that the data collection and reduction is not always adequate and sufficient due to human errors. DATEC field testing and scenario evaluation did not address the question of long term trend analysis in great detail, but one scenario (Appendix S, Special RSL Long Term Test) was included to specifically illustrate at least some aspects of the utility of long term (in this case - hours) trend analysis. Data from this scenario is presented in graph form in Figures 6-1 through 6-6 . This data shows at a glance the correlation and interaction

PROCEDURE	DATE	TIME
L1. At HUA, connect attenuators (X1 and X10) between Equalizer and IF in RX A as shown in Figure L-1.	6-14-77 ATC	0750
L2. With power off the radio and DATEC equipment at HUA, do solder the AGC A lead coming from the radio to the Analog Scanner at Analog Scanner TB1-13. Connect a jumper wire between TB1-13 and 18. Reapply power; put equipment into operation.		0751
L3. Introduce attenuation at the approximate rate of one ^{two} dB every 5 minutes. Do not drop below squelch threshold. Record time when each addition of attenuation is made:		
STARTING WITH 10 ¹⁵ dB:		
	-1dB -2	0755
	-2dB -4	0800
	-3dB -6	0805
	-4dB -8	0810
	-5dB -10	0815
	-6dB -12	0820
	-7dB -14	0825
	-8dB -16	0830
	-9dB -18	0840
	-10dB -20	0850
	-11dB -22	
	-12dB -24	
	-13dB -26	
	-14dB -28	
	-15dB -30	
	-16dB -32	
	-17dB -34	
	-18dB -36	
	-19dB -38	
	-20dB -40	
	-21dB	
	-22dB	
	-23dB	
	-24dB	
	-25dB	
L4.) Restore equipment to base line condition at completion of test.		
CONDUCTED BY <u>C. L. Christner</u> 6-14-77		
OBSERVED BY _____		

DATEC SYSTEM EVALUATION WORKSHEET 14 June 77, Pg # 1

OBSERVANCE (key points only)	PRINTOUT REF (ATTACH)	DATE	TIME
All Sy stems are green and/or normal...//./cs Displays indicate the RSL margin at HUA is beginning to degrade...//RR	1-4/ 14 June 77	6/14	0741
System at HUA switched to the "B" recvr..No indication as to why...//RR	5/14 June 77		0831
Attempted to manually switch the recv at HUA back to the "A" recvr...unable to do this...//RR			0839
Locked HUA Recv on the "B" recvr...Requested maint check out the "A" recvr..See RSL margin degraded, and also see the Eye margin on the "A " recvr degrading...//RR	5-6/14 June 77		0845
Maint advsd they had a bad IF int the "A" Recv.. The "A" recvr now back on line and fivers...//RR			0854
Problem resolved:::::Bad IF within the "A " Recvr at HUA...//RR			0910
<hr/> <p>Following displays were useful in tracing the problem....</p> <p>1....LS Pg # 1 2....LP Pg # 1</p> <p>NOTE: Displays indicating faulty Eye data on "A" ra dio at SBL...Turned over to maint to check the system...//RR</p> <p>NOTE: Honeywell advsd appears to be a bad relay card in the EPUT scanner at SBL.. They swapped with a spare...//RR/Eye hits clear, however now showing bad Eye Amplitude..Honeywell still checking ...//RR</p> <p>Problem cleared by Honeywell...//cs</p>			
TECH CONTROLLER			0925
OBSERVED BY	CMS		0953
			1015

```

MAS
RA. 0 A
      B
MUX SW
      A
      B
CY104

TIWB1

TELEMETRY.
SITE

```

SYSTEM OVERVIEW

TIME 165/0742:19

Page 1 / 14 June 77

AS-2

LINK STATUS

TIME 165/0743:11

	T1-4000.....	RADIO.....	
		HUA	SBL	HUA	SBL
ALARM	SW MAJOR	.	.	TX PROB	.
	SW MINOR	.	.	RX PROB	.
	MAJOR	.	.		.
STATUS	TX IN SVC	A	A	TX IN SVC	A A
	RX IN SVC	A	A	RX IN SVC	A A
	MAINT	.	.	MAINT	.
PARAMETER	FER	<1.0E-7	<1.0E-7	RX SQUELCH	.
	CRFRM	.	.	RSL MARGIN	29.487 . 40.556
	BER COR	NO DATA	NO DATA	EYE MARGIN	13.369 . 12.914
				EYE AMPL	-8.8065 . -9.0741
				EYE HITS	0.0 . 0.0
				DER BER	1.6E-13 . 3.0E-13

PAGE 1

BEST AVAILABLE COPY

MAS	LINK STATUS	TIME 165/0714:23
CY-104.....TIME1.....
	HUA SBL	HUA SBL
ALARM	SERVICE	OFFICE
	REMOTE	
STATUS	MAINT	MAINT
PARAMETER	CHANNEL	FER <1.0E-6
		REFRAME <1.0E-6
SITE ALARMS	ENTRY	
	FIRE	
	AC PWR	
	BATTERY	
	W.A. PR	
	N.G. HV	
	FLOOD	

2 / 14 June 77

10-007	LINK PERFORMANCE ASSE	NT - RADIOS	TIME 165/0745:30
	LAST LAST HR LAST 24 HR	ST 30 DAYS LAST 30 MTHS	
	SCAN AN MEAN DEV	AN DEV MEAN DEV	
HUA	RSLMAR 22.437 2 36 30.346 .66225	449 6.9754	----- DB
A	EYEMAR 13.369 1 28 12.647 1.7949	203 3.5695	----- DB
	RSLAVL 1.0000 1 00 1.0000	-----	----- RATE
	EYEAVL 1.0000 1 00 0.9933	22835	----- RATE
	EYEHIT 0.0 0 0 5.3825 17.073	19.584 49.266	----- /SC
HUA	RSLMAR 27.843 21 79 25.776 7.4342	30.239 1.2699	----- DB
B	EYEMAR 5.1807 5 24 6.9377 3.8304	7.8934 3.3995	----- DB
	RSLAVL 1.0000 1 00 0.9934	0.9939	----- RATE
	EYEAVL 1.0000 1 00 0.9867	0.9966	----- RATE
	EYEHIT 0.0 0 0 11.067 24.393	0.3601 4.5277	----- /SC
SBL	RSLMAR 40.556 38 34 38.799 1.2932	38.091 1.4336	----- DB
A	EYEMAR 12.914 13 17 13.520 .34644	13.142 .54955	----- DB
	RSLAVL 1.0000 1 00 1.0000	1.0000	----- RATE
	EYEAVL 1.0000 1 00 1.0000	0.9983	----- RATE
	EYEHIT 0.0 0 0 3.2155 37.979	1.7443 3.1994	----- /SC
B	RSLMAR 33.636 32 97 34.016 .21702	33.520 1.3755	----- DB
	EYEMAR 13.482 13 44 13.438 .83309	12.876 1.2276	----- DB
	RSLAVL 1.0000 1 00 1.0000	1.0000	----- RATE
	EYEAVL 1.0000 1 00 1.0000	0.9983	----- RATE
	EYEHIT 0.0 0 0 .08134 .22675	.34547 2.5253	----- /SC

IC 008

		LINK PERFORMANCE ASSESSMENT - RADIOS						TIME 165/0747:45		
		LAST SCAN	LAST HR MEAN	LAST 24 HR MEAN	LAST 24 HR DEV	LAST 30 DAYS MEAN	LAST 30 DAYS DEV	LAST 30 MPH MEAN	LAST 30 MPH DEV	
HUA	EYEVOL	-3.7600	-3.7750	-3.7312	.33837	-4.0050	.36952	-----	-----	VLIS
A	RXSQH	0.0	0.0	6.0000	-----	3.0000	-----	-----	-----	RTE
HUA	EYEVOL	-4.5400	-4.5450	-4.3741	.40326	-4.2616	.27684	-----	-----	VLIS
B	RXSQH	0.0	0.0	5.0000	-----	12.000	-----	-----	-----	RTE
HUA	LNKAVL	1.0000	1.0000	.28033	-----	4.0000	-----	-----	-----	RTE
SBL	EYEVOL	-3.8000	-3.7775	-3.6605	.27574	-3.7633	.36840	-----	-----	VLIS
A	RXSQH	0.0	0.0	1.0000	-----	14.000	-----	-----	-----	RTE
SBL	EYEVOL	-3.7500	-3.7533	-3.6788	.27160	-3.7084	.11742	-----	-----	VLIS
B	RXSQH	0.0	0.0	1.0000	-----	9.0000	-----	-----	-----	RTE
SBL	LNKAVL	1.0000	1.0000	1.0000	-----	1.0000	-----	-----	-----	RTE

3 / 14 June 77

IC-005

		LINK PERFORMANCE ASSESSMENT - CI-4001						TIME 165/0748:47		
		LAST SCAN	LAST HR MEAN	LAST 24 HR MEAN	LAST 24 HR DEV	LAST 30 DAYS MEAN	LAST 30 DAYS DEV	LAST 30 MPH MEAN	LAST 30 MPH DEV	
HUA	FER	1.0E-15	3.0E-16	2.0E-9	-----	5.5E-9	-----	-----	-----	RTE
A	FERAVL	1.0000	1.0000	1.0000	-----	1.0000	-----	-----	-----	RTE
	CRFRM	0.0	0.0	7.0000	-----	2.3000	2.5710	-----	-----	RTE
	CR/SQH	0.0	0.0	4.0000	-----	1.0000	-----	-----	-----	RTE
	CR/HIT	0.0	0.0	2.0000	-----	2.0000	-----	-----	-----	RTE
HUA	FER	1.0E-15	3.3E-17	-----	-----	2.0E-10	-----	-----	-----	RTE
B	FERAVL	1.0000	1.0000	1.0000	-----	1.0000	-----	-----	-----	RTE
	CRFRM	0.0	0.0	6.0000	-----	2.0000	2.2238	-----	-----	RTE
	CR/SQH	0.0	0.0	4.0000	-----	1.0000	-----	-----	-----	RTE
	CR/HIT	0.0	0.0	2.0000	-----	1.0000	-----	-----	-----	RTE
SBL	FER	1.0E-15	2.7E-16	3.9E-6	-----	5.3E-7	-----	-----	-----	RTE
A	FERAVL	1.0000	1.0000	1.0000	-----	1.0000	-----	-----	-----	RTE
	CRFRM	0.0	0.0	4.0000	-----	1.6000	2.1541	-----	-----	RTE
	CR/SQH	0.0	0.0	0.0	-----	4.0000	-----	-----	-----	RTE
	CR/HIT	0.0	0.0	0.0	-----	5.0000	-----	-----	-----	RTE
SBL	FER	5.2E-10	5.2E-11	1.2E-11	-----	1.3E-7	-----	-----	-----	RTE
B	FERAVL	1.0000	1.0000	1.0000	-----	1.0000	-----	-----	-----	RTE
	CRFRM	0.0	0.0	5.0000	-----	1.0000	1.9105	-----	-----	RTE
	CR/SQH	0.0	0.0	0.0	-----	3.0000	-----	-----	-----	RTE
358	CR/HIT	0.0	0.0	0.0	-----	3.0000	-----	-----	-----	RTE

BEST AVAILABLE COPY

4 / 14 June 77

AS-2 LINK PERFORMANCE ASSESSMENT - TIWBI TIME 165/0749:50

	LAST SCAN	LAST HR MEAN	LAST 24 HR MEAN	LAST 24 HR DEV	LAST 30 DAYS MEAN	LAST 30 DAYS DEV	LAST 30 MTHS MEAN	LAST 30 MTHS DEV	
HUA FER	1.2E-14	4.0E-15	5.0E-15	-----	4.9E-6	-----	-----	-----	RTE
RFRM	0.0	0.0	8.0000	-----	4.5000	4.0311	-----	-----	RTE
SBL FER	1.2E-14	3.6E-15	4.7E-5	-----	1.0E-5	-----	-----	-----	RTE
RFRM	0.0	0.0	7.0000	-----	3.1000	3.4771	-----	-----	RTE

IQ-006 MAINTENANCE VOLTAGES - 4JA TIME 165/0753:30

NO.	NAME	VOLTS	C	RH	AH	CG	AL	RL	MEAN	DEV	INITIAL DATE
01	TIWBI+15	15.5	G	16.5	15.7	15.0	14.2	13.5	15.5	.043	153/0907
02	TIWBI+12	12.4	G	13.2	12.6	12.0	11.4	10.8	12.4	.012	153/0907
03	T14000+5	4.96	G	5.50	5.25	5.00	4.75	4.50	4.95	.007	153/0907
04	T14000-6	-6.08	G	-5.40	-5.70	-6.00	-6.30	-6.60	-6.08	.002	153/0907
05	RADIO+24	24.0	G	26.4	25.2	24.0	22.3	21.6	23.9	.030	153/0907
06	RADIO-20	-19.9	G	-18.0	-19.0	-20.0	-21.0	-22.0	-19.9	.014	153/0907

BEM-3-M0-I2 MAINTENANCE VOLTAGES - SBL TIME 165/0751:36

NO.	NAME	VOLTS	C	RH	AH	CG	AL	RL	MEAN	DEV	INITIAL DATE
01	TIWBI+15	15.1	G	16.5	15.7	15.0	14.2	13.5	15.1	.060	153/0911
02	TIWBI+12	12.3	G	13.2	12.6	12.0	11.4	10.8	12.3	.010	153/0911
03	T14000+5	4.95	G	5.50	5.25	5.00	4.75	4.50	4.94	.004	153/0911
04	T14000-6	-6.06	G	-5.40	-5.70	-6.00	-6.30	-6.60	-6.06	.015	153/0911
05	RADIO+24	24.1	G	26.4	25.2	24.0	22.3	21.6	24.1	.012	153/0911
06	RADIO-20	-20.1	G	-18.0	-19.0	-20.0	-21.0	-22.0	-20.1	.014	153/0911

BEST AVAILABLE COPY

#5 14 June 77

IQ-005

		LINK STATUS		TIME 165/0331:34	
	T1-4000.....	RADIO.....	
		HUA	SBL	HUA	SBL
LARM	SW MAJOR	.	.	TX PROB	.
	SW MINOR	.	.	RX PROB	.
	MAJOR	.	.		
STATUS	TX IN SVC	A	A	TX IN SVC	A
	RX IN SVC	A	A	RX IN SVC	A
	MAINT	.	.	MAINT	.
PARAMETER	FER	<1.0E-7	<1.0E-7	RX SQUELCH	.
	CRFRM	.	.	RSL MARGIN	27.390 . 36.700
	BER COR	NO DATA	NO DATA	EYE MARGIN	13.369 . 13.331
				EYE AMPL	-8.9677 . -8.9355
				EYE HITS	0.0 . 0.0
				DER BER	1.6E-13 . 8.4E-14
					PAGE 1

AS-2

		LINK PERFORMANCE ASSESSMENT - RADIOS						TIME 165/0333:03	
		LAST SCAN	LAST HR	LAST 24 Hr	LAST 30 DAYS	LAST 30 MTHS	MEAN	DEV	
		MEAN	MEAN	DEV	MEAN	DEV			
HUA	RSLMAR	27.390	27.794	30.260	.79673	27.449	6.9354	-----	DB
A	EYEMAR	13.369	12.876	12.624	1.7938	10.903	3.5695	-----	DB
	RSLAVL	1.0000	1.0000	1.0000	-----	.93454	-----	-----	RATE
	EYEA VL	1.0000	1.0000	0.9935	-----	.92835	-----	-----	RATE
	EYEHIT	0.0	0.0	5.3325	17.073	19.684	49.066	-----	ZSO
HUA	RSLMAR	28.835	29.109	25.552	7.3253	30.239	1.9649	-----	DB
B	EYEMAR	5.5670	5.6153	6.6551	3.7117	7.0934	3.4005	-----	DB
	RSLAVL	1.0000	1.0000	0.9935	-----	0.9939	-----	-----	RATE
	EYEA VL	1.0000	1.0000	.9367	-----	0.9266	-----	-----	RATE
	EYEHIT	0.0	0.0	11.368	24.398	3.3601	4.5271	-----	ZSO
SBL	RSLMAR	36.700	38.250	33.814	1.2952	33.391	1.4336	-----	DB
A	EYEMAR	13.482	13.685	13.511	.84534	13.142	.54950	-----	DB
	RSLAVL	1.0000	1.0000	1.0000	-----	1.0000	-----	-----	RATE
	EYEA VL	1.0000	1.0000	1.0000	-----	0.9983	-----	-----	RATE
	EYEHIT	0.0	0.0	0.2155	37.073	1.7443	3.1090	-----	ZSO
SBL	RSLMAR	32.750	33.371	33.995	.92691	23.520	1.3750	-----	DB
	EYEMAR	14.421	14.421	13.422	.82657	12.576	1.9276	-----	DB
	RSLAVL	1.0000	1.0000	1.0000	-----	1.0000	-----	-----	RATE
	EYEA VL	1.0000	1.0000	1.0000	-----	0.9983	-----	-----	RATE
	EYEHIT	0.0	0.0	.13434	.22675	.84542	2.5063	-----	ZSO

#6 14 June 77

		LINK STATUS		TIME 165/0339:46	
	TI-4000.....	RADIO.....	
		HUA	SBL	HUA	SBL
ALARM	SW MAJOR	.	.	TX PROB	.
	SW MINOR	.	.	RX PROB	.
	MAJOR	.	.		
STATUS	TX IN SVC	A	A	TX IN SVC	A
	RX IN SVC	A	A	RX IN SVC	A
	MAINT	.	.	MAINT	.
PARAMETER	FER	<1.0E-7	<1.0E-7	RX SQUELCH	.
	CRFRM	.	.	RSL MARGIN	20.094 . 37.200
				EYE MARGIN	6.0500 . 13.482
	BER COR	NO DATA	NO DATA	EYE AMPL	-9.0741 . -8.9355
				EYE HITS	0.0 . 0.0
				DER BER	8.5E-13 . 1.4E-13

PAGE 1

10-1-18-23		MAINTENANCE VOLTAGES - HUA							TIME 165/0347:55		
									INITIAL		
NO.	NAME	VOLTS	C	RH	AH	CG	AL	RL	MEAN	DEV	DATE
01	TIWB1+15	15.6	G	16.5	15.7	15.0	14.2	13.5	15.5	.043	153/0907
02	TIWB1+12	12.4	G	13.2	12.6	12.0	11.4	10.8	12.4	.012	153/0907
03	TI4000+5	4.96	G	5.50	5.25	5.00	4.75	4.50	4.95	.037	153/0907
04	TI4000-6	-6.08	G	-5.40	-5.70	-6.00	-6.30	-6.60	-6.08	.002	153/0907
05	RADIO+24	24.0	G	26.4	25.2	24.0	22.8	21.6	23.9	.030	153/0907
06	RADIO-20	-19.9	G	-18.0	-19.0	-20.0	-21.0	-22.0	-19.9	.014	153/0907

10-1-08-10		LINK PERFORMANCE ASSESSMENT - RADIOS					TIME 165/0351:59		
		LAST SCAN	LAST HR	LAST 24 HR	LAST 30 DAYS	LAST 30 MTHS			
		MEAN	MEAN	DEV	MEAN	DEV	MEAN	DEV	
HUA	RSLMAR	25.116	27.531	37.260	.79673	27.449	6.9354	-----	DB
A	EYEMAR	6.3500	12.687	12.624	1.7093	10.908	3.5695	-----	DB
	RSLAVL	1.0000	1.0000	1.0000	-----	.93454	-----	-----	DB

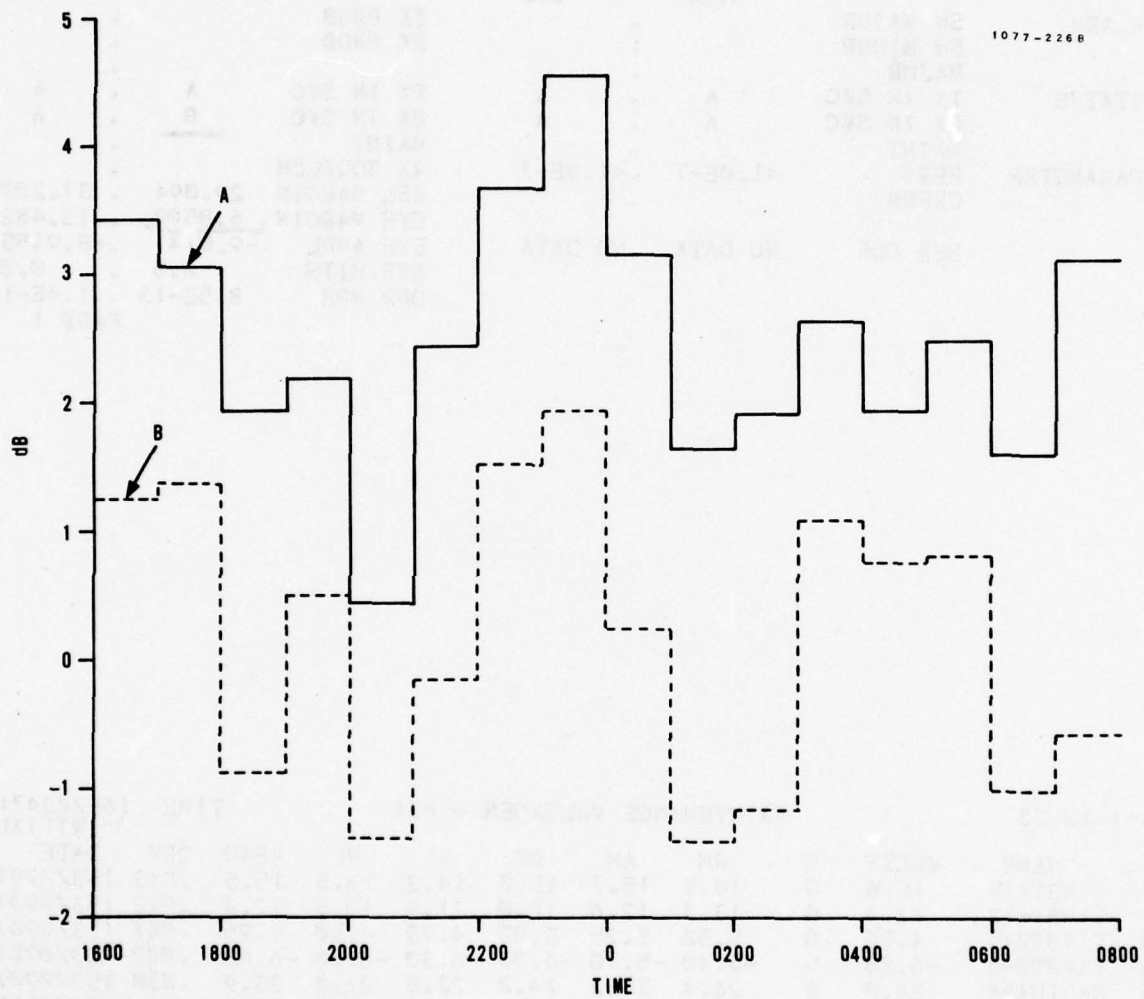

FIGURE 6-1. RSL MARGIN

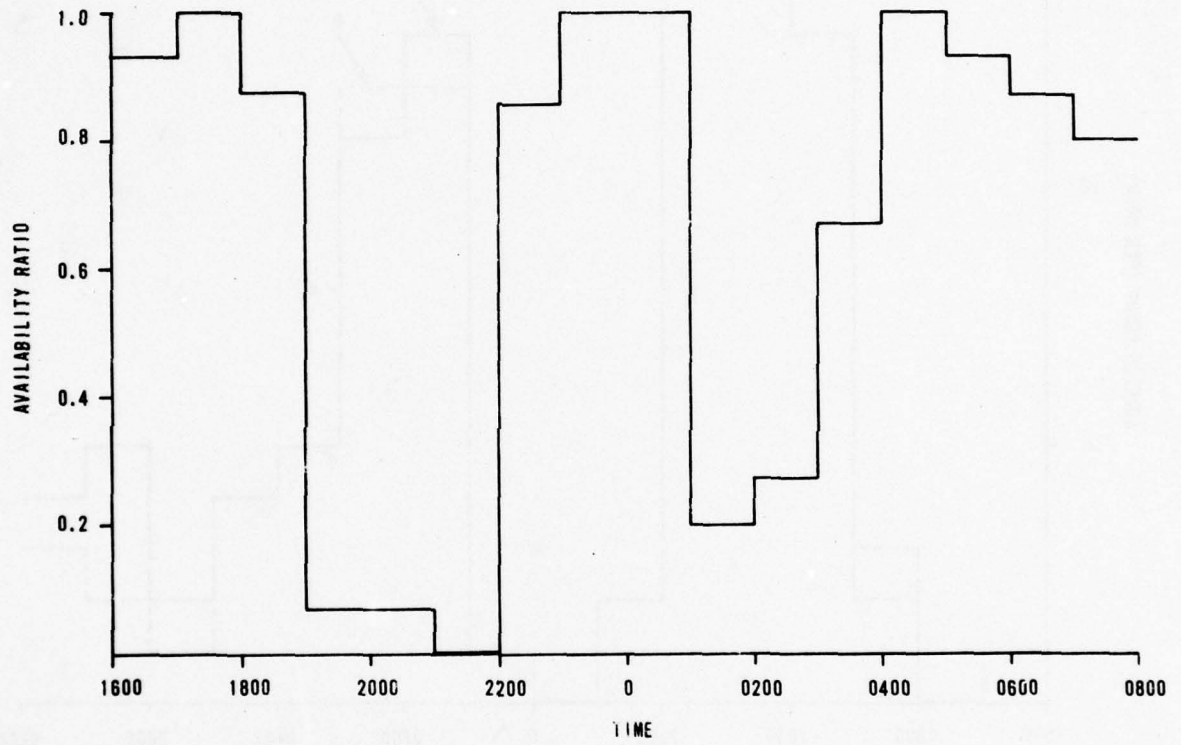

FIGURE 6-2. LINK AVAILABILITY

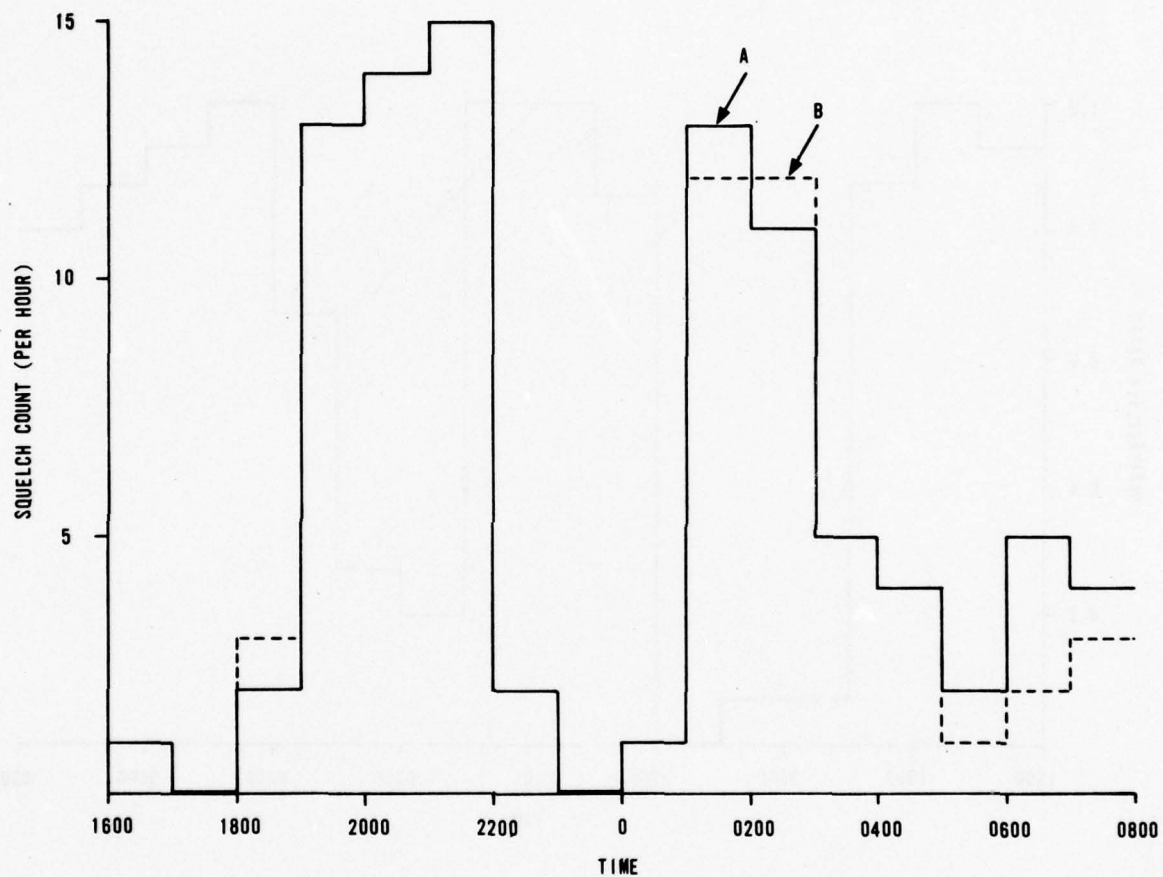

FIGURE 6-3. RECEIVER SQUELCH

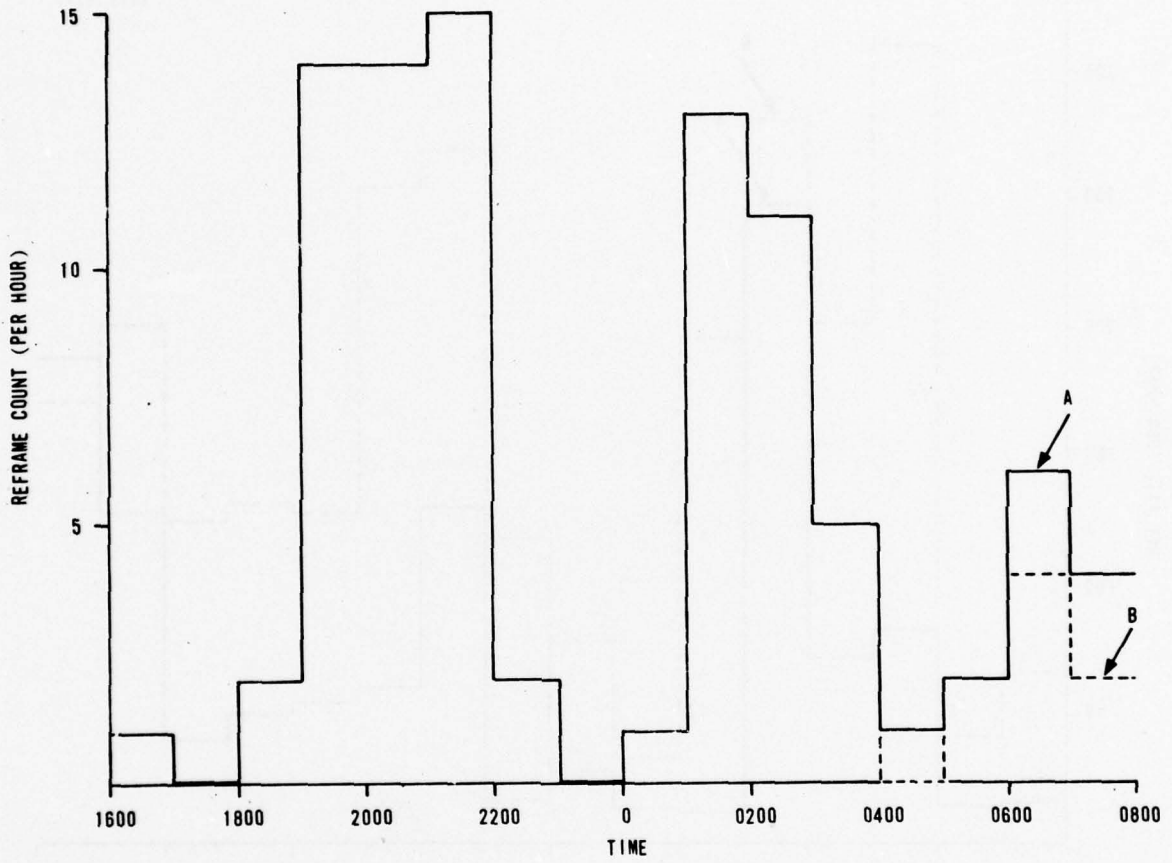

FIGURE 6-4. CONTROL REFRAMES (T1-4000)

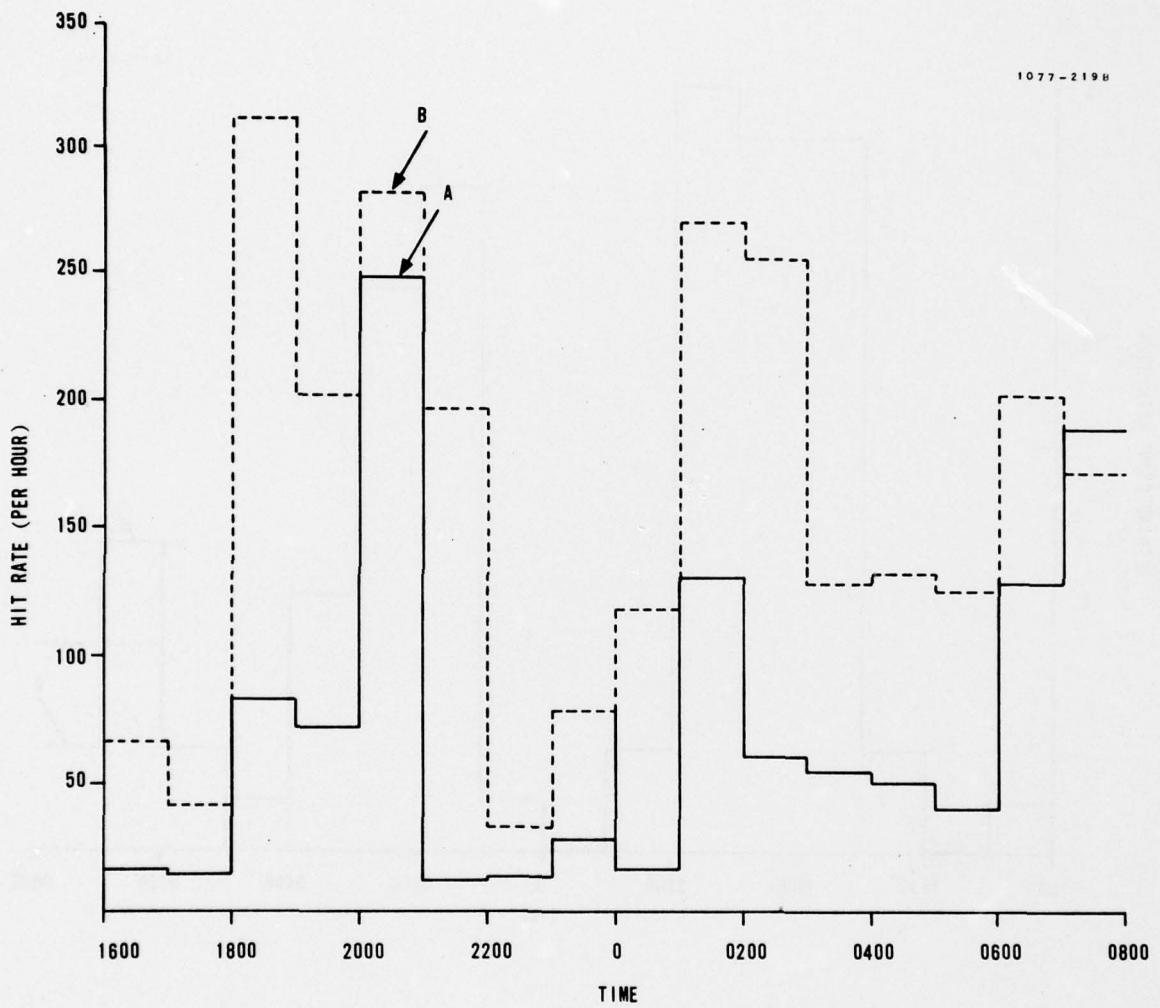

FIGURE 6-5. EYE HITS

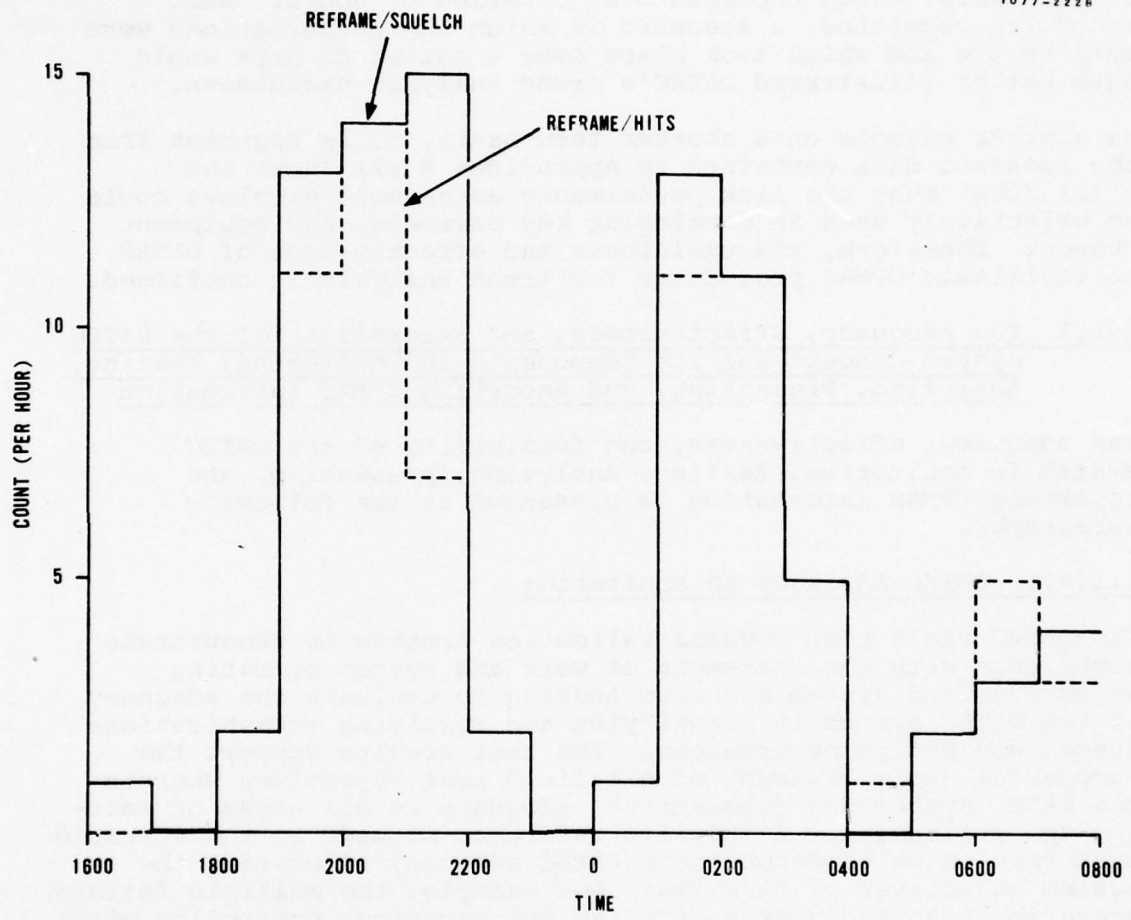

FIGURE 6-6. REFRAME CORRELATION COUNT.

of key parameters over the 16 hour period the scenario was conducted. Even this scenario does not fully exploit the potential advantages of long term trending relative to manpower requirements. It does serve to point out clearly the cause and effect relationships which occurred over a period of hours. Had schedules permitted, a scenario in which the perturbations were more subtle and which took place over a matter of days would have better illustrated DATEC's trend analysis usefulness.

As another example on a shorter term basis, it is apparent from the scenario data contained in Appendices R (21 June) and N (21 June) that the link performance assessment displays could be effectively used in developing key parameter and equipment trends. Therefore, the usefulness and effectiveness of DATEC to facilitate CPMAS procedures for trend analysis is confirmed.

6.1.8 The Adequacy, Effectiveness, and Feasibility of the DATEC System Concept and its Components in Monitoring, Testing, Analyzing, Presenting, and Reporting CPMAS Information

The adequacy, effectiveness, and feasibility of the DATEC system in monitoring, testing, analyzing, presenting, and reporting CPMAS information is presented in the following paragraphs.

6.1.8.1 DATEC Adequacy in Monitoring

The DATEC field test covered validation testing to demonstrate compliance with the statement of work and system operating objectives and system scenario testing to evaluate the adequacy of the DATEC system in identifying and resolving communications system and equipment problems. The test results support the successful accomplishment of all field test objectives wherein the DATEC system was demonstrated adequate in all areas of testing and evaluation. A specific reference is made to the scenario test results which demonstrate DATEC adequacy in meeting the system objectives of PA/FI/TA. For example, the multiple failure scenario in Appendix EE confronted the technical controller with a cross section of problem types addressing both hard equipment failures and more subtle equipment degradation. The technical controllers were able to resolve the problems in a straightforward manner using the DATEC system alarm and parameter information. Furthermore, the technical controllers stated near the end of the test program that they could think of no other alarms or monitor points which should be added to DATEC to improve the system adequacy in monitoring for PA/FI/TA.

6.1.8.2 DATEC Adequacy in Testing

The DATEC system adequacy in testing addresses the DATEC capability to accomplish communications system and equipment testing in both a sufficient and accurate manner as to provide the

PROCEDURE	DATE	TIME															
<p>R1. At the HUA in-service receiver waveguide, using the HP 570-30 Directional Coupler and HP 620B SHF Signal Generator, apply the following frequencies (deviation from center received frequency) at the levels and for the period of time indicated:</p> <table border="1"> <thead> <tr> <th>Frequency (Rec'd Freq.)</th> <th>Level</th> <th>Time</th> </tr> </thead> <tbody> <tr> <td>+ 3.15 MHz</td> <td>-20, -30 & -40dBm0</td> <td>TBB</td> </tr> <tr> <td>- 3.15 MHz</td> <td>-20, -30 & -40dBm0</td> <td>"</td> </tr> <tr> <td>+ 6.3 MHz</td> <td>-20, -30 & -40dBm0</td> <td>"</td> </tr> <tr> <td>- 6.3 MHz</td> <td>-20, -30 & -40dBm0</td> <td>"</td> </tr> </tbody> </table>	Frequency (Rec'd Freq.)	Level	Time	+ 3.15 MHz	-20, -30 & -40dBm0	TBB	- 3.15 MHz	-20, -30 & -40dBm0	"	+ 6.3 MHz	-20, -30 & -40dBm0	"	- 6.3 MHz	-20, -30 & -40dBm0	"		
Frequency (Rec'd Freq.)	Level	Time															
+ 3.15 MHz	-20, -30 & -40dBm0	TBB															
- 3.15 MHz	-20, -30 & -40dBm0	"															
+ 6.3 MHz	-20, -30 & -40dBm0	"															
- 6.3 MHz	-20, -30 & -40dBm0	"															
<p>R2. At the completion of step R1, restore equipment to baseline configuration.</p>																	
<p>R3. At HUA, using an HP 606B (or equivalent) test oscillator and the summing amp (a special piece of test equipment) configured as shown in Figure R-1, apply the following frequencies at the levels and for the period of time indicated:</p>	<p>6-21-77</p>																
<table border="1"> <thead> <tr> <th>Frequency</th> <th>Level</th> <th>Time</th> </tr> </thead> <tbody> <tr> <td>1.544MHz</td> <td>-20 and -30dBm0</td> <td>TBD</td> </tr> <tr> <td>3.088MHz</td> <td>-20 and -30dBm0</td> <td>"</td> </tr> <tr> <td>6.176MHz</td> <td>-20 and -30dBm0</td> <td>"</td> </tr> <tr> <td>12.352MHz</td> <td>-20 and -30dBm0</td> <td>"</td> </tr> </tbody> </table>	Frequency	Level	Time	1.544MHz	-20 and -30dBm0	TBD	3.088MHz	-20 and -30dBm0	"	6.176MHz	-20 and -30dBm0	"	12.352MHz	-20 and -30dBm0	"	<p>6-21-77</p>	<p>1240 -40 1255 -30 1305 -25 1312 -20</p>
Frequency	Level	Time															
1.544MHz	-20 and -30dBm0	TBD															
3.088MHz	-20 and -30dBm0	"															
6.176MHz	-20 and -30dBm0	"															
12.352MHz	-20 and -30dBm0	"															
<p>R4. At the completion of step R3, restore equipment to baseline configuration.</p>		<p>1328</p>															
<p>CONDUCTED BY <u>C. J. Christy</u> 6-21-77</p> <p>OBSERVED BY _____</p>																	

DATEC SYSTEM EVALUATION WORKSHEET

21 June 1977/pg #3

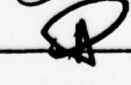
OBSERVANCE (key points only)	PRINTOUT REF (ATTACH)	DATE	TIME
systems green...//RR		6/21	1300
System overview show amber on the REC "A" mux and TLWBL..../ph	#5/21 June 1977		1310
Request maint switch from "A" to "B" rec mux at HUA....and check out the "A" mux for framing error tbls..../ph			1312
Maint a dvise that "A" mux is good, when we shifted to the "B" mux all amber conditions cleared...advised maint to switch to "A" mux. maint advise possible cause of framing errors was a clean-up team working in and around the mux may have jarred something..../ph			1315
SBL "B" radio in amber on system overview, reason unknown..asked SBL to check his radio,..//ph	6/7/21 June 1977		1316
Link performance indicates both eye margins are low on SBL rec..../ph			1320
Requested that SBL check out for any interference on his rec..../ph			1325
Maintenance advises that he is send the interference on his transmitter, he switched to the "B" transmittte r while he is working on the "A"...../ph			1328
Dis lays used: System overview Link Status Link performance (Most Help)			
TECH CONTROLLER			
OBSERVED BY			

PROCEDURE	DATE	TIME
<p><u>Reciprocal Path Problem</u></p> <p>N1. Insert 10dB of attenuation between equalizer and IF in the A and B receivers at both HUA and SBL.</p>		
<p><u>Transmit Antenna Only at Sibyl</u></p> <p>N2. Insert 10dB of attenuation between equalizer and IF in the A and B receivers at HUA and the B receiver only at SBL. <i>(Accomplished by inserting 10dB of attenuation in transmit waveguide @ SBL)</i></p> <p>N3. Restore equipment to baseline configuration</p>	<p>6-21-77</p>	<p>1100 1100 1109</p>
<p>CONDUCTED BY <u>C. L. Christner</u> 6-21-77</p> <p>OBSERVED BY _____</p>		

DATEC SYSTEM EVALUATION WORKSHEET 21 June 77, Pg # 2

OBSERVANCE (key points only)	PRINTOUT (ATTACH)	DATE	TIME
<p>Systems again Green...///RR</p> <p>SYNXX Maint advised they are taking control of the system cause something wrong....</p> <p>System returned to Control...all green....</p> <p>System overview shows Amber Inservice on the "A" rcvr at HUA and Amber Standby on the "B" radio rcvr at HUA..../pjh</p> <p>Link performance displays show low rec rsl on both ra dios at HUA..../ph</p> <p>Requested SBL switch to the "B" transmitter to HUA..../pjh</p> <p>RSL continues to drop...SBL switched back to "A" xmtr..../pjh</p> <p>REquested maint have SBL check out their transmit antenna to HUA.../pjh</p> <p>Maint advised SBL transmit antenna off alignment, antenna team corrected to restore service...</p> <p>All systems good att..../pjh</p>	<p>3/21 June 1977</p> <p>4/21 June 1977</p>	<p>6/21</p>	<p>0930</p> <p>1034</p> <p>1055</p> <p>1100</p> <p>1102</p> <p>1103</p> <p>1106</p> <p>1108</p> <p>1110</p> <p>1111</p>
<p>Displays Used....</p> <ol style="list-style-type: none"> 1. System overview 2. Link Status 3. Link performance (Best for this problem) <p>TECH CONTROLLER _____</p> <p>OBSERVED BY _____</p>			

#1/2 June 17

IQ-005

		LINK PERFORMANCE ASSESSMENT - RADIOS						TIME 172/1102:53		
		LAST SCAN	LAST HR	LAST 24 HR	LAST 30 DAYS	LAST 30 DAYS	LAST 30 MTHS	LAST 30 MTHS		
			MEAN	MEAN	DEV	MEAN	DEV	MEAN	DEV	
HUA	RSLMAR	20.473	29.176	29.080	5.6110	27.369	10.649	-----	DB	
A	EYEMAR	12.346	12.233	10.499	2.7539	10.969	2.9468	-----	DB	
	RSLAVL	1.0000	1.0000	.95876	-----	.95222	-----	-----	RATE	
	EYEA VL	1.0000	1.0000	.96078	-----	.94612	-----	-----	RATE	
	EYEHIT	0.0	0.0	7.4687	19.879	12.749	37.582	-----	/SC	
HUA	RSLMAR	22.648	30.455	31.586	1.4104	27.611	9.1418	-----	DB	
B	EYEMAR	5.6637	5.7023	5.6673	1.8493	7.7197	2.5145	-----	DB	
	RSLAVL	1.0000	1.0000	1.0000	-----	.99167	-----	-----	RATE	
	EYEA VL	1.0000	1.0000	1.0000	-----	0.9947	-----	-----	RATE	
	EYEHIT	0.0	0.0	.06810	.07394	3.4285	5.2951	-----	/SC	
SBL	RSLMAR	38.200	38.543	39.315	.42963	37.956	2.3217	-----	DB	
A	EYEMAR	12.005	11.963	12.948	.31634	12.688	2.1798	-----	DB	
	RSLAVL	1.0000	1.0000	1.0000	-----	.98436	-----	-----	RATE	
	EYEA VL	1.0000	1.0000	1.0000	-----	0.9970	-----	-----	RATE	
	EYEHIT	0.0	0.0	0.0	0.0	1.3950	3.3337	-----	/SC	
SBL	RSLMAR	35.833	35.734	37.502	1.3026	33.937	2.6584	-----	DB	
B	EYEMAR	12.005	12.005	13.105	.16601	13.274	1.1154	-----	DB	
	RSLAVL	1.0000	1.0000	1.0000	-----	.98436	-----	-----	RATE	
	EYEA VL	1.0000	1.0000	1.0000	-----	0.9987	-----	-----	RATE	
	EYEHIT	0.0	0.0	.30126	.30356	.47788	1.9274	-----	/SC	

IQ-006

		LINK PERFORMANCE ASSESSMENT - RADIOS						TIME 172/1107:17		
		LAST SCAN	LAST HR	LAST 24 HR	LAST 30 DAYS	LAST 30 DAYS	LAST 30 MTHS	LAST 30 MTHS		
			MEAN	MEAN	DEV	MEAN	DEV	MEAN	DEV	
HUA	RSLMAR	13.896	18.896	23.742	5.5029	27.369	10.649	-----	DB	
A	EYEMAR	12.346	12.233	10.499	2.7539	10.969	2.9468	-----	DB	
	RSLAVL	1.0000	1.0000	.95652	-----	.95222	-----	-----	RATE	
	EYEA VL	1.0000	1.0000	.96078	-----	.94612	-----	-----	RATE	
	EYEHIT	0.0	0.0	7.4687	19.879	12.749	37.582	-----	/SC	
HUA	RSLMAR	21.044	21.044	31.372	1.4196	27.611	9.1418	-----	DB	
B	EYEMAR	5.6637	5.7023	5.6673	1.8493	7.7197	2.5145	-----	DB	
	RSLAVL	1.0000	1.0000	1.0000	-----	.99167	-----	-----	RATE	
	EYEA VL	1.0000	1.0000	1.0000	-----	0.9947	-----	-----	RATE	
	EYEHIT	0.0	0.0	.06810	.07394	3.4285	5.2951	-----	/SC	
SBL	RSLMAR	38.700	38.562	39.315	.42963	37.956	2.3217	-----	DB	
A	EYEMAR	12.005	11.963	12.948	.31634	12.688	2.1798	-----	DB	
	RSLAVL	1.0000	1.0000	1.0000	-----	.98436	-----	-----	RATE	
	EYEA VL	1.0000	1.0000	1.0000	-----	0.9970	-----	-----	RATE	
	EYEHIT	0.0	0.0	0.0	0.0	1.3950	3.3337	-----	/SC	
SBL	RSLMAR	27.182	34.665	37.502	1.3026	33.937	2.6584	-----	DB	
B	EYEMAR	11.562	11.734	13.105	.16601	13.274	1.1154	-----	DB	
	RSLAVL	1.0000	1.0000	1.0000	-----	.98436	-----	-----	RATE	
	EYEA VL	1.0000	1.0000	1.0000	-----	0.9987	-----	-----	RATE	
	EYEHIT	0.0	0.0	.30126	.30356	.47788	1.9274	-----	/SC	

technical controller the information he needs to maintain the digital transmission system performance requirements. The field testing addressed testing adequacy in two ways. First, the DATEC validation testing confirmed the basic measurement accuracy. Second, the DATEC scenario testing addressed the sufficiency of the measurements performed to enable the technical controller to maintain the communications system. Test results support the adequacy of DATEC in both the measurement accuracy and sufficiency areas.

Specific reference is made to Paragraph 6.1.3, wherein additional testing was performed to further evaluate the accuracy of the baseband eye monitor derived bit error rate and the event per unit time monitor measured multiplexer frame error rate when compared to the actual T1 bit error rate measured using a standard laboratory type bit error rate measuring set. The test results confirmed the accuracy and sufficiency in testing the communications system for BER.

6.1.8.3 Adequacy in Analyzing

The DATEC adequacy in analyzing the monitored data addresses two areas of the system performance. First, the adequacy in analyzing the data as it relates to the accuracy of the data analysis. Second, the adequacy in analyzing the data as it relates to the sufficiency of the data analysis. The validation test results in Appendices A through J of the Field Test and Evaluation Report address, in detail, the accuracy of the data analysis.

Particular attention was paid to the data processing and accuracy required in the data conversion and trending algorithms. The validation test data supports the adequacy of the monitor data analysis. The adequacy in data analysis, as it relates to sufficiency, is illustrated by the system scenario evaluation test results in Appendices K through FF, the excerpts of which are included throughout this section.

6.1.8.4 DATEC Adequacy in Presenting/Reporting

The DATEC system adequacy as it relates to the presenting and reporting of data addresses the CRT displays and formats. The technical controllers made repeated reference throughout the system scenario testing to the usefulness of the system overview display and the link status displays. See the scenario worksheets in Appendix DD for examples of such comments. The technical controllers recommended a different format for the system overview display when the system is used to monitor more than six sites. The proposed display content would remain essentially unchanged except for the addition of digroup and link identification numbers.

HIGHER MUX FAILURE, TIWBI CHANNEL CARD

PROCEDURE

DD1. At HVA, disable the NORMAL TI-4000 Channel 7 RCV. card by breaking the card edge connections to the card nest.

6-16-77 1107

DD2. At the completion of the test, reinsert the Channel 7 card into the card nest.

1124

Requested TIWBI loopback @ HVA & SBL @ 1113.

Normalled everything @ 1124

CONDUCTED BY

C. L. Christy 6-16-77

OBSERVED BY

DATEC SYSTEM EVALUATION WORKSHEET 16 June 77, Pg # 2

OBSERVANCE (key points only)	PRINTOUT REF (ATTACH)	DATE	TIME
Systems again Green...////RR		6/16	1100
CRT (overview) display indicates the TLWBL is RED Flagged, both at HUA and SBL...//RR	6/16 June 77		1107
Requested HUA maint pull in-house loop on the TLWBL...A lso requested they have SBL do same...//RR Maint voltages at HUA checked good...//RR			1112
Maint voltages at SBL check good also...In-house loop on the TLWBL at HUA is good...//RR			1114
Maint advsd that the in-house loop at SBL is good also...Requested SBL maint loop the TL-4000 chnl back to us...//RR			1120
Chnl loop frm SRM bad..Requested maint check chnk cards both here and at SBL...//RR			1123
Maint advsd that there was a bad recv chnl card on TL-4000 at HUA.. Maint replaced same...//RR			1125
<hr/>			
Problem isolated to bad recv chnl card in TL-4000 at HUA...//RR			
Displayse deemed useful.....			
<ol style="list-style-type: none"> 1. Systems overview 2. Link Status Pg # 2 			
<p>TECH CONTROLLER _____</p> <p>OBSERVED BY _____</p>			

#6 16 June 77

MA-2			SYSTEM OVERVIEW		TIME 16771133:17
	HUA	SBL		MAJOR ALARM	
RADIO A	.	.			
B	.	.			
MU. SW	.	.			
A	.	.			
B	.	.			
CY104	.	.			
	.	.			
	.	.			
	.	.			
	.	.			
	.	.			
	.	.			
	.	.			
	.	.			
TI 1	.RDI<>>MIR.	.			
	.	.			
	.	.			
TELEMETRY.			
SITE	.	.			

AE			LINK STATUS		TIME 16771139:05
		CY-104.....	TINDI.....
		HUA	SBL		HUA
ALARM	SERVICE	.	.	OFFICE	* . *
		.	.		.
	REMOTE	.	.		.
		.	.		.
STATUS	MAINT	.	.	MAINT	.
		.	.		.
PARAMETER	CHANNEL	.	.	ERR <1.0E-6	<1.0E-6
		.	.	REFFAYE	.
		.	.		
SITE	ENTRY	.	.		
ALARMS	FIRE	.	.		
	AC PHR	.	.		
	BATTERY	.	.		
	H.A. PR	.	.		
	T.O. HV	.	.		
	FLOOD	.	.		

PAGE 0

6.1.8.5 DATEC Effectiveness in Monitoring

Monitoring is defined to be the continual scanning, analysis, and reporting of system alarm and monitor points. This was the underlying design objective of the DATEC system. The successful demonstration of this capability was threaded throughout the field test results. In fact, the starting point for each of the scenarios was to place the DATEC system in the normal scan mode and wait until the system overview display alerted the technical controller to a system problem. There can be no doubt in the effectiveness of the DATEC monitoring function.

6.1.8.6 DATEC Effectiveness in Testing

The DATEC system effectiveness in testing addresses the usefulness of the measured data in allowing the technical controller to satisfy the performance requirements of the digital transmission system. The scenario test results in Appendices K through FF referred to in this section, demonstrate the usefulness of the measured parameters.

6.1.8.7 DATEC Effectiveness in Analysis

The DATEC system validation test results in Appendices A, B and E illustrate the system effectiveness in monitored data analysis and the resultant trend analysis of the monitored parameters. In each case the computer clock was moved ahead in order to move the data through the trend analysis tables. Using the acquired data, the effectiveness of the computer program in accomplishing the data reduction and trend analysis was confirmed.

6.1.8.8 DATEC Effectiveness in Presenting/Reporting

The DATEC effectiveness in the presenting and reporting of data was demonstrated by the system scenario evaluation testing and the technical controller comments as to the usefulness of the system overview and link status displays referenced on the technical controller worksheets (see pages 347 through 352).

6.1.8.9 DATEC Feasibility in Monitoring

The DATEC feasibility in monitoring CPMAS requirements was confirmed throughout the system scenario tests. The DATEC monitoring function is the foundation upon which the alarms and parameter data information collection process is built for it is the scanning, data analysis, and reporting of the measured information to the technical controller that enables him to maintain the required system performance. The feasibility of DATEC to perform monitoring was successfully accomplished for all alarms and parameters.

6.1.8.10 DATEC Feasibility in Testing

The DATEC feasibility in testing CPMAS requirements was confirmed by the validation test results in Appendices A through J of the Field Test and Evaluation Report. The validation tests addressed all the alarm and monitor point measurements required to monitor the digital transmission system. The successful execution of the validation testing demonstrated DATEC's feasibility in testing for CPMAS information.

6.1.8.11 DATEC Feasibility in Analyzing

The DATEC feasibility in analyzing data for CPMAS information was demonstrated throughout the field testing by the continual updating of monitored parameters. Test data illustrating the feasibility of DATEC data analysis is contained in the validation Appendices A through J in the Field Test and Evaluation Report.

6.1.8.12 DATEC Feasibility in Presenting/Reporting

The DATEC system feasibility in presenting and reporting CPMAS information is demonstrated by the usefulness of the CRT displays during the system scenario evaluation testing. Reference to the CRT display usefulness is addressed on the technical controller scenario worksheets wherein, taken collectively, it was stated that the system overview and link status displays were judged most useful followed by the link performance displays for certain classes of system degradation. Therefore, the feasibility of the CRT displays was successfully demonstrated, not only in their generation, but also in their application or usefulness in helping the technical controller accomplish the system goals of PA/FI/TA.

6.1.9 The Accuracy, Reliability, Utility, and Completeness of the Data Queries, Analyses, Summaries, and Output Displays

The accuracy, reliability, utility and completeness of the data queries, analyses, summaries, and output displays are addressed in the following paragraphs.

6.1.9.1 Accuracy Versus Data Queries and Analysis

The DATEC accuracy of data queries and analysis are documented in the validation test results in Appendices A through J. The test results document DATEC accuracy capabilities in the areas of monitor point data acquisition and its subsequent analysis. The demonstrated tolerances on voltage measurements were within the requirement of ± 1 percent. The demonstrated tolerances on derived parameters like BER and FER were within the requirement of ± 1 order of magnitude.

6.1.9.2 Accuracy of Summaries and Output Displays

The DATEC accuracy of summaries and output displays addresses the capability of DATEC to process the monitored data in such a manner as to enable the parameter value and trend analysis information to be a faithful reproduction of the actual data as it was collected by the monitor system. This faithful reproduction capability was confirmed as a part of the validation testing wherein the testing centered upon a cause and effect relationship for fault occurrence and measured value. The accuracy was confirmed by comparing DATEC measured values against those obtained using laboratory equipment (i.e., voltmeters) and then performing the computer analysis function by hand in order to make a direct comparison of the measured value accuracy to that presented on the CRT display. The DATEC system satisfactorily satisfied all accuracy and reporting tests performed during the field test.

6.1.9.3 Reliability of Data Queries, Analyses, Summaries, and Output Displays

The DATEC reliability as it applies to data queries, analyses, summaries and output displays addresses the usefulness and effectiveness of the DATEC monitored data in allowing the technical controller to accomplish PA/FI/TA on the digital transmission system. The system scenario test results in Appendices K through FF which appear throughout this section illustrate in the majority of cases that the technical controller was able to successfully execute the system scenario given the DATEC performance data. Examples exist, however, where the particular system degradation remained unconfirmed as to cause and effect in some instances. For example, Appendix K, the RF fade scenario, presented problems for the technical controllers when it addressed a single receiver RF fade.

This problem was particularly troublesome because the radio would switch to the standby unit upon the first occurrence of a single receiver fade thereby causing future fades to go unnoticed unless the technical controller happened to refer to the link performance assessment display for radio performance. Using this example, the reliability of the data queries and analysis was unaffected, however, the summaries and output displays failed in a few instances to adequately display to the technical controller the system problem. This apparent deficiency is easily resolved, however, by adding either more information to the system overview display or by placing alarm thresholds on the trend analysis information.

6.1.9.4 Utility of the Data Queries, Analyses, Summaries and Output Displays

The DATEC utility of the data queries, analyses, summaries, and output displays was one of the major items considered and evaluated during the field test. It was for this very purpose that the system evaluation scenarios were structured to include experienced technical controllers as part of the test team. In determining the utility of the DATEC system the technical controllers were given simulated link and equipment problems and then using the DATEC system they proceeded to identify and resolve the communications system fault or degradation. The test results in Appendices K through FF illustrate the utility of the data queries, analyses, summaries and output displays in the execution by the technical controllers of the system evaluation scenarios.

Specific reference is made to Appendix DD test scenario executed on 16 June wherein the system overview display alerted the technical controller to a problem in the TLWBI multiplexer. Through the use of the DATEC system, augmented by the results of equipment switchovers by maintenance, the technical controller was successful in identifying the problem as a failure in the Channel 1 receive card in the TI-4000 multiplexer thereby demonstrating the utility of the data queries, analyses, summaries and output displays. (Refer to pages 379 through 381.)

6.1.9.5 Completeness of Data Queries and Analyses

The DATEC completeness of data queries and analyses is demonstrated by the validation test results in Appendices A through J, and the comments from the technical controllers at the conclusion of the test program when they said that they felt the DATEC monitor point selection (data queries) and subsequent data processing was adequate to enable the technical controller to accomplish PA/FI/TA of the digital transmission system.

6.1.9.6 Completeness of Summaries and Output Displays

The DATEC completeness of summaries and output displays is illustrated by the successful execution of the system scenario evaluations in Appendices K through FF. The technical controllers were critical, however, of the format chosen for the system overview and link status displays. They made specific reference to the need for a different system overview format when monitoring more than six sites. It was also suggested that the link status display be reformatted. The recommended format changes are discussed in Paragraph 6.3.2.2.

6.1.10 The Accuracy, Reliability, and Utility of the DATEC Measurements Relative to Circuits of Different Qualities, (i.e., Determine the Operational Scope of the DATEC Measurements)

Throughout the rest of this report, the discussions regarding PA/FI/TA pertain mainly to digital circuit qualities, and there are numerous examples to illustrate DATEC's utility and effectiveness in this area. One capability of DATEC which has not been discussed in much detail is the IQCS measurement made on the VF channels of the CY-104.

The DATEC system uses the PATE configured as an ISVF (in-service voice frequency) monitor for making in-service channel measurements. The DATEC selected VF channel measurements are those of average power level and 2600 Hz signal to noise. These measurements are made on those channels which are selected for scanning by DATEC. The complete ISVF in-service measurement capability, including a channel spectrum plot, is available using operator interaction (Monitor Immediate) on those channels connected to DATEC or on any other VF channel by connecting it to DATEC through the patch panel on the PATE equipment rack.

The validation test in Appendix H addressed the DATEC VF measurement capability by performing measurements on both 1000 Hz and 2600 Hz tones. The system was demonstrated as being able to accurately measure both average levels and 2600 Hz signal to noise ratios.

The system scenario evaluation testing which addressed VF channel measurements is in Appendix W. The scenario execution as accomplished by the tech controllers on 9 June 1977, demonstrated the reliability and utility of the measurement data in identifying and correcting VF channel problems. The scenario execution made use of the DATEC monitor immediate capability to identify the channel problems using the measured data and VF spectrum plot. Having access to the complete ISVF measurement and analysis capability provided a valuable tool in further analyzing the channel level problems.

In order to further evaluate the DATEC capability relative to circuits of different qualities, additional VF channel testing was performed using a VF channel simulator on loan from RADC.

The channel simulator was connected to Channel 1 of the CY-104. The purpose of the test was to see if the ISVF, which is designed for in-service measurements only, could be useful in identifying VF channel problems other than those affecting average level or 2600 Hz signal to noise ratio. The channel simulator provided the capability of injecting broadband noise, impulse noise, phase hits, and phase jitter onto a VF channel.

PROCEDURE	DATE	TIME
W1. Connect the Hip 654 test oscillator to the HDA CY-104, channel number 1.	6/9/77	1455
W2. Set the level at the channel input to -20dBm0 at 2600 Hz \pm 10 Hz.		1455
W3. After 10 minutes reduce the level of the 2600 Hz tone by 10dB and continue to reduce the signal level at a rate of 5dB per 5 minutes until a total of 40dB attenuation is introduced. This corresponds to a signal level of -60dBm0. Record the time each increment of attenuation is introduced.		1505
<p style="text-align: center;">10dB 15dB 20dB 25dB 30dB 35dB 40dB 45dB 50dB 55dB 60dB</p>	<p style="text-align: center;">PROB. IDENTIFIED AFTER 10 dB DROP IN 2600 Hz SIG. LEVEL</p>	1505
W4. Set the test oscillator signal level to -13dBm at the channel input at 1000 Hz \pm 10 Hz.	6/9/77	1535
W5. After 10 minutes increase the signal level by 3dB and continue to increase the signal level by 1dB every 5 minutes until the signal level is +12dBm0. Record the time the signal level is increased.		1545
<p style="text-align: center;">3dB 4dB 5dB 6dB 7dB 8dB 9dB 10dB 11dB 12dB</p>	<p style="text-align: center;">PROB IDENTIFIED AFTER 3dB INCREASE IN 1000 Hz SIG. LEVEL.</p> <p style="text-align: right;">COMPLETED</p>	1600
CONDUCTED BY <u>T. Connolly 6/9/77</u>		
OBSERVED BY <u>✓</u>		

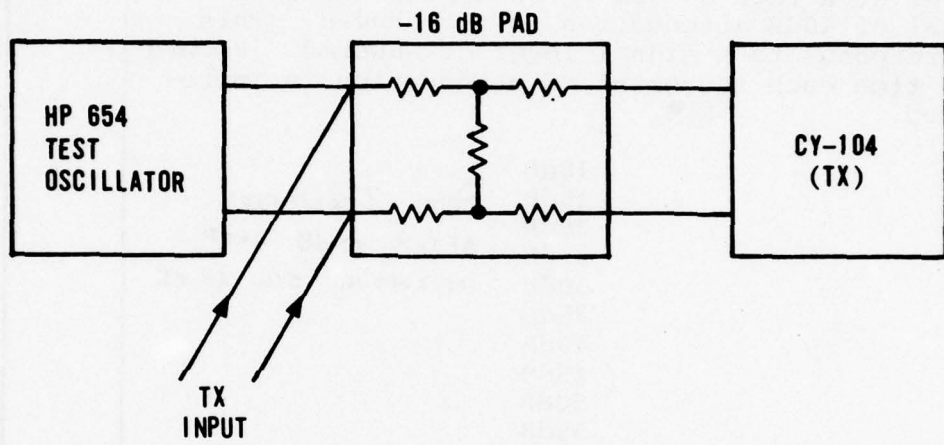



Figure W-1. Test Configuration,
User VF Channel Degradation

DATEC SYSTEM EVALUATION WORKSHEET
9 June 1977

Page #4

OBSERVANCE (key points only)	PRINTOUT REF (ATTACH)	DATE	TIME
All stat & sys clear		6/9	1500
System overview shows problem on the CY104 (Amber) .../ph	19/9	6/9	1503
Link status shows amber channel on the CY104 at HUA...Trying to isolate problem.../ph	19/9	6/9	1505
After using "G1" and getting channel stats, found that the rec channel one at HUA, S/N was in amber, advised maint to check out channel.../ph	20/9	6/9	1506
66			
The GI dump proves to be a fast and efficient way of locating particular problems within the channel on the CY104 (SO FAR ???)			
Maintenance advises that there was a bad rec channel on the CY104 at HUA/Replaced...ph			1510
END PART I			
All systems Clear		6/9	1546
Link Status and System Overview indicate CY 104 3 in amber...//cs	21/ 9June 77		1548
GI Channel Scan indicated HUA had a hot transmit, on channel 1. from user, requested user check his level, he adjusted his levels and problem cleared at 1558...//cs	22/ 9June 77		1550
problem was hot customer level.			
System Overview inconjunction with the GI Channel Scan program were highly effective in problem isolation./cs			
TECH CONTROLLER 			
OBSERVED BY 			

20/9 June 77

AL SN+31.1 S 160/1506 0006
Av 3.9 FR+2604 CN-45.0 SN+31.1AL WF-44.6 NC+15.8
VU-13.8 PA+00.6 MI+00.1 M5+00.1 FR+2604 SW+0072

SPECTRUM 6----5----4----3----2----1----0----1

01 -64.7
02 -63.9
03 -64.0
04 -63.1
05 -63.0
06 -62.5
07 -62.5
08 -63.6
09 -51.4*****
10 -45.9*****
11 -51.9*****
12 -62.6
13 -59.6*
14 -60.8
15 -64.7
16 -63.2
17 -62.8
18 -63.3
19 -64.0
20 -63.4
21 -62.1
22 -62.3
23 -62.8
24 -56.9**
25 -20.5*****
26 -13.9*****
27 -19.4*****
28 -54.4***
29 -61.8
30 -63.3
31 -64.3
32 -64.0
33 -64.0
34 -65.3
35 -66.1
36 -65.6
37 -68.5
38 -70.7
39 -71.3
40 -70.9

#21 9 June 77

MAS	LINK STATUS		TIME 160/154
CY-104.....	TIWBI.....
	HUA	SBL	HUA SBL
ALARM	SERVICE	.	OFFICE
	REMOTE	.	
STATUS	MAINT	.	MAINT
PARAMETER	CHANNEL 01A	.	FER <1.0E-6
		.	REFRAME
SITE ALARMS	ENTRY	.	
	FIRE	.	
	AC PWR	.	
	BATTERY	.	
	W.A. PR	.	
	W.G. HV	.	
	FLOOD	.	

PAGE 2

IQ-006	SYSTEM OVERVIEW		TIME 160/1548:51
	HUA	SBL	
RADIO A	.	.	
B	.	.	
MUX SW	.	.	
A	.	.	
B	.	.	
CY104	.A01>	.	
	.	.	
	.	.	
	.	.	
	.	.	
TIWBI	.	.	
	.	.	
TELEMETRY.	
SITE	.	.	

#22 9 June 77

61

160/1550

1c 1550 MT.NO=00 MODE= 02

CY-104...HUA...CH'S..1&13

AH AV-10.6 IT 160/1550 0005

AV-10.6AH FR+1004 CN-84.5 SN+73.8 WF-74.6 HD+69.3

VJ-10.6 PA+00.0 M1+00.3 M5+00.0 FR+1004 SN+0072

SPECTRUM 6-----5-----4-----3-----2-----1-----0-----1

- 01 -73.2
- 02 -93.1
- 03 -93.1
- 04 -93.1
- 05 -93.1
- 06 -76.7
- 07 -67.1
- 08 -54.9***
- 09 -17.2*****
- 10 -10.7*****
- 11 -16.2*****
- 12 -53.7****
- 13 -66.8
- 14 -75.7
- 15 -93.1
- 16 -93.1
- 17 -93.1
- 18 -93.1
- 19 -93.1
- 20 -93.1
- 21 -93.1
- 22 -93.1
- 23 -93.1
- 24 -93.1
- 25 -93.1
- 26 -93.1
- 27 -93.1
- 28 -93.1
- 29 -93.1
- 30 -79.9
- 31 -93.1
- 32 -93.1
- 33 -93.1
- 34 -93.1
- 35 -93.1
- 36 -93.1
- 37 -93.1
- 38 -93.1
- 39 -93.1
- 40 -93.1

The test results showed that the ISVF was very effective in measuring stationary perturbations (except phase jitter) but that its usefulness in catching transient events, like impulse noise, is dependent upon the ISVF taking a channel signal sample coincident with the transient event occurrence in order for the ISVF to be effective in detecting the perturbation.

The test results are included as a part of this write-up for reference. The testing addressed the DATEC measured VF channel performance during induced perturbations of broadband noise, impulse noise, phase hits, and phase jitter. A summary of the test results is presented in Table 6-7.

The test results demonstrate the need to be able to make a comprehensive set of VF measurements on selected channels. This can be easily accomplished by using the PATE configured as an I/OSVF instead of its current ISVF configuration. The test results also illustrate the usefulness of the spectrum plot in analyzing VF channel problems like increasing PCM quantizing noise, which would be readily apparent as a reduction in the signal to noise ratio.

6.1.11 The Accuracy, Reliability, and Utility of the Performance Assessment/Trend Analysis Capabilities to Resolve Degradations

Relative to the accuracy and reliability of DATEC's performance assessment and trend analysis (PA/TA) capabilities, this was verified during the validation phase of field tests. The key performance indicators such as RSL Margin, the Eye parameters-- Eye Margin and Derived Bit Error Rate-- and the T1-4000 and T1WB1 Frame Error Rate parameters were thoroughly checked with regard to alarming and trending. The parameter trending software algorithm was verified for the three basic types of parameters: value, ratio, and count, through the "last 30 mths" columns of the Link Performance Assessment display (see in particular the field test data for Appendices B and D in Section II of the Field Test and Evaluation Report).

Except for the scenario of Appendix S, Special RSL Long Term Test, there were no tests conducted wherein degradation to the communication system was monitored over a relatively long period of time (that is, hours or days). There were, however, several scenarios which provide good examples of how-- even on a short term basis-- the tech controllers were able to utilize DATEC's PA/TA capabilities to resolve degradations. These examples address primarily the utility aspect of this topic; however, reliability is also demonstrated if it is considered that almost 60 scenarios were conducted over a 2-1/2 month period of time, wherein the PA/TA capabilities of DATEC were relied upon by the tech controllers to resolve degradations. The consistency which was displayed throughout this phase of field tests with regard to problem detection and isolation underscores the dependability of these DATEC capabilities.

TABLE 6-7. DATEC MEASURED VF CHANNEL PERFORMANCE

<u>Test Description</u>	<u>Case No.*</u>	<u>Test Results</u>
1. Baseline Test. 1000 Hz Tone at -13 dBm	1	Established baseline for comparison.
2. Impulse noise added to baseline. Impulse rate is 10/sec.	2 ₁	VF channel analysis shows presence of noise in the channel. Signal type is identified as wideband noise.
	2 ₂	VF channel analysis shows no presence of noise. Signal type is identified as a test tone. This illustrates the problem of trying to catch a transient event using a one-time sampled measurement device.
		<u>NOTE:</u> This measurement is normally performed by counting amplitude hits over several minutes as in the I/OSVF.
3. Phase hits and phase jitter added to baseline. Phase hit control was set to maximum and phase jitter was set to 60 Hz at 30 degrees.	3	VF channel analysis shows no presence of either phase hits or phase jitter. It is not surprising that the ISVF does not detect phase hits and phase jitter, it does not contain the required processing circuitry. These measurements are performed by the I/OSVF.
4. Broadband noise added to baseline.	4	VF channel analysis clearly identifies broadband noise since this type of interference is stationary and easily detected.

* See following data display printouts.

CASE 1

VF CHANNEL TESTING

IQ, MI, 6, 0, 3

G AV-13.1 TT 131/1340 0006
 AV-13.1G FR+0097 CN-48.7 SN+35.6 WF-38.9 HD+44.7
 VU-13.1 PA+01.0 MI+00.2 M5+00.0 FR+0097 SW+0071
 VIJ-13.1 PA+01.0 SN+0071 FR+0097 M5+00.0

SPECTRUM 6----5----4----3----2----1----0----1

- 01 -38.2*****
- 02 -49.9*****
- 03 -55.4***
- 04 -56.7**
- 05 -59.9*
- 06 -60.3
- 07 -60.4
- 08 -57.2**
- 09 -18.8*****
- 10 -13.1*****
- 11 -19.6*****
- 12 -57.7**
- 13 -57.4**
- 14 -53.2*
- 15 -61.9
- 16 -62.6
- 17 -61.9
- 18 -62.3
- 19 -61.5
- 20 -57.8**
- 21 -60.7
- 22 -62.9
- 23 -63.1
- 24 -63.0
- 25 -63.7
- 26 -58.5*
- 27 -57.6**
- 28 -62.0
- 29 -62.7
- 30 -63.9
- 31 -62.3
- 32 -61.5
- 33 -60.9
- 34 -62.0
- 35 -63.0
- 36 -65.0
- 37 -67.2
- 38 -69.6
- 39 -73.8
- 40 -69.6

G AV-13.1 TT 131/1341 0006
 AV-13.1G FR+0097 CN-49.3 SN+35.6 WF-39.4 HD+45.3
 VU-13.1 PA+01.0 MI+00.3 M5+00.0 FR+0097 SW+0071
 VIJ-13.1 PA+01.0 SN+0071 FR+0097 M5+00.0

SPECTRUM 6----5----4----3----2----1----0----1

- 01 -38.3*****
- 02 -48.9*****
- 03 -55.3***
- 04 -57.0**
- 05 -59.6*
- 06 -60.7

CASE 2.

IQ, MI, 6, 0, 3

AV-13.1 N 181/1343 0006
AV-13.1 PA+05.7 CN-13.2 FN-13.1 WF-13.1
VU-13.0 PA+05.7 MI+00.9 M5+00.2 FR+0097 SW+0076
VU-13.0 PA+05.7 SW+0076 FR+0097 M5+00.2

SPECTRUM 6----5----4----3----2----1----0----1

01 -37.8*****
02 -43.3*****
03 -43.0*****
04 -43.2*****
05 -43.3*****
06 -43.9*****
07 -44.8*****
08 -45.4*****
09 -18.7*****
10 -13.1*****
11 -19.5*****
12 -53.0***
13 -54.2***
14 -56.3**
15 -60.9
16 -59.4*
17 -57.3**
18 -56.6**
19 -54.8***
20 -53.7***
21 -55.5***
22 -56.1**
23 -55.7***
24 -55.1***
25 -57.4**
26 -56.5**
27 -57.5**
28 -62.0
29 -63.5
30 -63.9
31 -53.0
32 -61.6
33 -59.2*
34 -60.5
35 -64.5
36 -64.3
37 -66.7
38 -67.9
39 -70.3
40 -70.4

9 AV-13.1 TF 181/1343 0006
AV-13.16 FR+0097 CN-49.3 SN+66.7 WF-38.2 HD+44.7
VU-13.3 PA+05.3 MI+01.2 M5+00.3 FR+0097 SW+0071
VU-13.0 PA+05.3 SN+0071 FR+0097 M5+00.3

CASE 2.

SPECTRUM 6----5----4----3----2----1----0----1

01 -38.0*****
02 -49.2*****

93 -55.7 ***
94 -56.1 **
95 -59.8 *
96 -59.3
97 -59.6 *
98 -56.7 **
99 -18.7 *****
100 -13.1 *****
11 -19.5 *****
12 -57.2 **
13 -57.7 **
14 -52.1 *
15 -52.1
16 -52.3
17 -53.4
18 -53.6
19 -59.4
20 -57.0 **
21 -61.0
22 -62.0
23 -60.3
24 -53.3
25 -62.8
26 -53.6 *
27 -57.3 **
28 -61.4
29 -54.0
30 -53.5
31 -63.4
32 -62.7
33 -62.9
34 -63.4
35 -63.6
36 -65.3
37 -67.9
38 -63.1
39 -62.5
40 -70.0

BEST AVAILABLE COPY

CASE 3

IQ, MI, 6, 0, 3

G AV-13.1 TI 181/1345 0036
AV-13.16 FR+0097 CN-48.6 SN+35.5 WF-38.7 ND+44.0
VJ-13.1 PA+01.0 MI+00.2 MS+00.1 FR+0097 SW+0071
VU-13.1 PA+01.0 SN+0071 FR+0097 MS+00.1

SPECTRUM 6----5----4----3----2----1----0----1

01 -38.0*****
02 -48.3*****
03 -55.7***
04 -57.5**
05 -58.7*
06 -59.5*
07 -60.8
08 -56.1**
09 -13.3*****
10 -13.1*****
11 -12.6*****
12 -57.5**
13 -57.3**
14 -58.4*
15 -62.2
16 -62.4
17 -62.4
18 -61.2
19 -63.3
20 -58.7*
21 -63.4
22 -61.2
23 -61.6
24 -63.6
25 -62.4
26 -58.9*
27 -57.3**
28 -62.6
29 -64.2
30 -63.1
31 -62.7
32 -62.6
33 -61.5
34 -61.7
35 -62.6
36 -63.7
37 -67.1
38 -67.7
39 -71.9
40 -73.5

BEST AVAILABLE COPY

CASE 4

IQ, MI, 6, 0, 3

AV-11.9 NH 181/1346 0006
AV-11.9 PA+06.6 PI-05.4 R1+01.8
VU-11.7 PA+06.6 M1+02.4 M5+00.8 FR+0996 SW+0774
VU-11.7 PA+06.6 SW+0774 FR+0996 M5+00.8

SPECTRUM 6-----5-----4-----3-----2-----1-----0-----1

01 -34.7*****
02 -33.8*****
03 -32.7*****
04 -31.7*****
05 -32.0*****
06 -31.4*****
07 -31.6*****
08 -32.5*****
09 -13.3*****
10 -13.1*****
11 -19.4*****
12 -33.1*****
13 -32.2*****
14 -30.0*****
15 -30.6*****
16 -31.7*****
17 -31.2*****
18 -31.0*****
19 -31.3*****
20 -31.0*****
21 -32.1*****
22 -31.4*****
23 -31.6*****
24 -32.2*****
25 -32.3*****
26 -31.4*****
27 -30.0*****
28 -30.0*****
29 -31.4*****
30 -31.4*****
31 -31.7*****
32 -32.3*****
33 -33.1*****
34 -33.3*****
35 -34.3*****
36 -37.0*****
37 -41.5*****
38 -50.2*****
39 -55.9*****
40 -63.4

AV-11.9 NH 181/1347 0006

181/1347 MI. 40=00 MODE= 00

The first two examples were taken from Appendix L scenario, Receiver Noise Figure Degradation - A Versus B, conducted on the 8th of June (see pages 242 through 248), and 14th of June (see pages 354 through 361).

Another illustration of degradation recognition may be found in the test data for Appendix R scenario, RFI and Abnormal Interference, conducted on 13 June 1977 (see pages 283 through 290). Note in this particular scenario that the problem is further identified through use of the display of the hourly statistics file for Receiver A Eye Margin at Ft. Huachuca.

6.1.12 The Fault Location Times as Affected by DATEC

No test scenarios were written especially to demonstrate this facet of DATEC's capability, primarily for one reason. The DATEC system provides the nodal controller with a number of fault detection and isolation capabilities for which there is no manual equivalent. It would be a simple matter then to choose one or more of this type of system anomaly and write scenarios which illustrate this lack of manual capability. Correspondingly, the fault location times would be tremendously impacted by DATEC. Depending on the subtleness of some of the anomalies, they could go unrecognized indefinitely without the use of DATEC.

It is acknowledged that for some types of problems such as those involving hard equipment failures, especially in those cases resulting in loss of service, the communication system is suitably alarmed (either audibly or visually) such that the tech controller receives warning within seconds of a failure. Reaction time in these instances would be comparable if manual versus DATEC-aided isolation was considered.

To illustrate the type of problems which could go unnoticed under manual surveillance for long periods or indefinitely, and the usefulness of DATEC relative to detection and isolation of such anomalies, the following test data is offered.

The test scenario of Appendix L simulated a receiver whose noise figure was steadily degrading. In this scenario conducted on 8 June 1977 (see pages 242 through 248), the tech controller was able to trace the problem using the Eye parameters, Margin and Hits. At the time that he requested Maintenance to lock on the B receiver and check the A receiver at Ft. Huachuca, the system BER was still good. There would have been no warning of this type of problem if the tech controller had been unaided by DATEC until disruption of service when the baseband had degenerated far enough to cause MUX errors and switching. None of the daily, weekly or monthly preventive maintenance checks would have detected this.

6.1.13 The Output Data Relative to its Utility in Optimizing Preventative Maintenance Schedules and the Maintenance Effort of the FKV Type Equipment

At Ft. Huachuca and Site Sibyl radio checks are made at daily, weekly and monthly intervals for preventative maintenance purposes. The check lists for these operations are shown in Figures 6-7, 6-8, and 6-9.

Of these operations, some may be directly accomplished by DATEC, others are effectively checked by inference from data that is measured by DATEC. Power supply voltages may be directly measured via the analog scanners and MAC units. For the field tests, only a few voltages were randomly selected for demonstration purposes. In an actual installation, all key power supply voltages should be monitored.

AGC voltage is another directly measurable quantity. After appropriate conversion, it is displayed as the more useful parameter, RSL Margin, that is, the margin between actual RSL and the PCM threshold, -71 dBm.

Other items such as proper transmit power and frequency, receiver frequency and pilot levels may be verified by inference from the general "health" of the link as noted by observing other DATEC monitored parameters. The best example of this is transmit power. Because a total picture of the operational status of a link is made available to the nodal controller by DATEC, such a problem can be easily detected and isolated. The Appendix M scenario, Transmitter Power Output Problems, was included in the field tests to illustrate this facility. Data for the 14 June execution of this scenario is included in pages 342 through 345.

In this example, the RSL pattern at Site Sibyl was the key. Since it is possible to detect gradual degradation of RSL over a period of time using the trend analysis capability of DATEC, this information can be used for preventive maintenance purposes, before service is disrupted.

Obviously, DATEC cannot generate a curve of RSL versus AGC. However, the purpose of getting this information on a monthly basis is primarily to detect degradation or shifts in receiver performance. As just pointed out, this information is available in DATEC and is continually being updated. The fact that data of this type is being continually monitored and updated points out another aspect of DATEC's usefulness. The purpose of a preventive maintenance program is to check potential problem areas with the objective of detecting degradations which could lead to major problems such as loss of service or even catastrophic failure. Hopefully, the preventive maintenance schedule is such that these degradations are caught as they are

WEEKLY DATA SHEET (DEB)

EQUIPMENT	SERIAL NR	MODEL (e.g. Preproduction)
MANUFACTURER SITE	ORDER NR N/A	SPECIFICATION NR N/A
TYPE OF TEST AN/FRC 162-165 WEEKLY CHECKLIST		SPECIFICATION PARAGRAPH N/A

Test Jack	Z	Unbal or Bal	Brdg or Term	Nor Level	1st Week	2nd Week	3rd Week	4th Week	5th Week
-----------	---	--------------------	--------------------	--------------	-------------	-------------	-------------	-------------	-------------

TRANSCEIVER A

J1-A PCM	75	Unbal	Term	-46dBm					
J1-A Pilot	75	Unbal	Term	-70dBm					
J2-A SerChan	75	Unbal	Term	-59dBm					
J25-A Pilot	75	Unbal	Term	-70dBm					
J58-A PCM	75	Unbal	Term	-17dBm					
J58-A Pilot	75	Unbal	Term	-41dBm					
J58-A SerChan	75	Unbal	Term	-30dBm					

TRANSCEIVER B

J1-A PCM	75	Unbal	Term	-46dBm					
J1-A Pilot	75	Unbal	Term	-70dBm					
J2-A SerChan	75	Unbal	Term	-59dBm					
J25-A Pilot	75	Unbal	Term	-70dBm					
J58-A PCM	75	Unbal	Term	-17dBm					
J58-A Pilot	75	Unbal	Term	-41dBm					
J58-A SerChan	75	Unbal	Term	-30dBm					

WECO JACKFIELD

J36	600	Bal	Brdg	-7dBm					
J12	600	Bal	Brdg	0dBm					
J14	75	Unbal	Term	-15dBm					
J16	600	Bal	Term	-5dBm					

ANCILLARY CARD CAGE

A S/L/S -2.00V				-2VDC					
B S/L/S -2.00V				-2VDC					

REMARKS (1) Inject a 1MHz test tone in J24 at +2.5 dBm.
 (2) The distand end inject a 1MHz test tone in J24 at +2.5 dBm.
 (3) Inject a 5KHz test tone in J15 at -15dBm.
 (4) The distand end inject a 5KHz test tone in J15 at -15dBm.
 (5&6) The distand end inject a 2KHz test tone in J15 at -15dBm.
 (7) Not in service.

DATE	PAGE NR	SIGNATURE	TABLE
------	---------	-----------	-------

Note! Enter Actual Reading in Blanks

MONTHLY DATA SHEET (DEB)

EQUIPMENT		SERIAL NR		MODEL (e.g. Preproduction)				
MANUFACTURER		ORDER NR		SPECIFICATION NR				
SITE		N/A		N/A				
TYPE OF TEST		AN/FRC 162-165 Monthly Checklist		SPECIFICATION PARAGRAPH				
				N/A				
					Month	Month	Month	Month
Test Jack								
TRANSCEIVER A								
Coaxial Coupler	Freq							
	PWR							
WaveGuide Coupler (at top of radio)	Freq							
	PWR							
TRANSCEIVER B								
Coaxial Coupler	Freq							
	PWR							
WG Coupler (at top of radio)	Freq							
	PWR							
ANCILLARY CARD CAGE								
Pilot OSC	Freq							
F.M. Subcarrier	Freq							
AGC VOLTAGE VS RSL								
Attach charts to rear of data sheet								
REMARKS								
DATE	PAGE NR	SIGNATURE					TABLE	

Note! Enter Actual Reading in Blanks

developing. The obvious problem is that if some electronic function is going to degrade, it is not going to do so on any particular schedule. A component in the IF strip could start to fail the day after an RSL versus AGC curve was generated as part of monthly preventive maintenance.

With respect to the utility of DATEC's output data relative to optimizing preventative maintenance schedules, it may be said that there would be no fixed schedule regarding the checks that are now being made. Using the performance assessment and trend analysis capabilities of DATEC, degradations would be automatically detected and alarmed upon. Taking units off-line for replacement or repair would be accomplished when a function had degraded to an alarm state. This first level of alarm condition (amber) would naturally be chosen such that it was reached before service had degraded below link performance objectives.

See also Paragraph 6.2.1 for further discussion of this topic as it relates to manning structure.

6.1.14 The Ability of DATEC to Provide Sufficient Information to Determine the Proper Thresholds for Alarm/Parameter Indicators

Alarm thresholds are normally based upon expected performance and then adjusted as required from long-term trend analysis data. The situation at the test link between Ft. Huachuca and Site Sibyl used during these field tests were slightly different. The initial thresholds were established based on expected performance of the equipment or characteristics of the link (medium); but the adequacy of the chosen thresholds was gauged primarily on how well they served the purpose during the System Simulation Scenarios. In either case, there is sufficient data provided to optimize the thresholds. Following is a discussion of how the alarm thresholds were established for the various types of parameters and the considerations that were given relative to their adequacy.

RSL Margin. The site data base tables for RSL versus AGC were developed from actual measurements taken at the site. RSL Margin is the difference between RSL and -71 dBm, the PCM threshold. From observation of the RSL Margin parameters at Ft. Huachuca and Site Sibyl, mean values were chosen as a baseline. It was noted that under normal weather conditions RSL Margin would vary from 1 to 2 dB from these mean values. The amber flag threshold was chosen (somewhat arbitrarily) as 6 dB below the mean value for each radio at each site. The red flag threshold was selected (in an equally arbitrary manner) at 12 dB below the mean. These thresholds were established as they were not because of any significant change in communication systems performance as the threshold values were crossed, but rather to call attention to the fact that RSL Margin was deviating further

and further from the expected link performance. Crossing thresholds, then, merely alerted the operator that received signal levels were not as they should be, based on nominal operation.

The usefulness of these thresholds was displayed in a very practical manner on at least one occasion. At 1445 hours on 15 June 1977, it was noted that RSL Margin for the B receiver at Ft. Huachuca and for the A and B receivers at Sibyl were all approximately 8 dB lower than the baseline values. A sustained wind of about 20 mph was blowing outside (at the Ft. Huachuca antenna tower) at the time. A check of the tower revealed that a flexible waveguide feeding the transmit antenna had split.

Eye Margin and Derived BER (DER BER). These two parameters are covered together because they are both derived from the same input-- eye dispersion voltage-- and because they are both correlated with each other and with measured BER. The amber threshold originally chosen for DER BER was 1×10^{-7} . The amber threshold for Eye Margin was that value of margin corresponding to the Eye Dispersion voltage that resulted in the 1×10^{-7} DER BER value. The red thresholds were based on a dispersion voltage which resulted in a 1×10^{-5} DER BER. The 1×10^{-7} BER is the minimum performance objective for an FKV type link. As the test scenario phase of field tests progressed, it was noted that there was sufficient sensitivity and resolution in the BEM derived parameters to warrant tightening the thresholds for DER BER to 1×10^{-9} and 1×10^{-7} for amber and red, respectively. Eye Margins were correspondingly changed. This resulted, in those scenarios featuring use of Eye parameters, in detection and isolation of perturbations introduced to the communication system before those perturbations induced bit error rates in excess of 1×10^{-7} (see example in Paragraph 6.1.3).

Eye Amplitude. This is another BEM derived parameter which is a negative dc voltage proportional to the RMS baseband power level into the Baseband Active Coupler. Nominally the level at this point is -9 dBm. In both radios tested, a special monitor point for this parameter was provided. This voltage was noted during data base generation for the AN/FRC-162 radio to be relatively stable, and did not vary more than a few tenths of a dB from nominal. The amber and red threshold levels were set at ± 0.75 dB from nominal and ± 1.5 dB from nominal, respectively. Examination of data taken throughout the remaining phases of field tests indicated that the Eye Amplitude parameter remained constant for the radios at both sites. Based on these observations, the thresholds could have been set tighter-- say ± 0.5 dB for amber and ± 1.0 dB for red.

Eye Hits. Hits are 3-level partial response errors which are counted by the self-contained EPUT in the BEM. The actual output from the BEM is a negative dc voltage proportional to Eye Hits. Design of the hit counter function in the BEM is such that it begins to detect hits when the Baud error rate reaches 10^{-12} . The hits counting function and the BER as derived by the dispersion meter within the BEM may or may not correlate depending upon the type of noise present. Transient occurrences such as deep fades that cause simultaneous squelches of both receivers will result in a hit count, whereas the DER BER parameter, derived from dispersion voltage, may show no perturbation, depending upon when the dispersion voltage was sampled. The Eye Hits parameter, then, is most useful in detection of transient type disturbances.

The thresholds for Eye Hits were chosen as 0.0222/sec and 1.888/sec for amber and red, respectively. Considering the bit rate of 12.5 Mb/s, this corresponds roughly to 10^{-9} and 10^{-7} bit error rates. These thresholds are more or less arbitrary. It was noted at the start of field tests under normal weather conditions and with no perturbations being deliberately introduced to the communication system, that no hits were ever recorded. Two hits per BEM 90-second sample period, which is what the amber threshold of 0.0222/sec is, therefore seemed to be a logical initial selection. Subsequent field test operations involving the AN/FRC-162 radio did not yield any additional data that warranted changing the thresholds.

It will be noted from examination of the field test scenario data that the Eye Hits parameter never was used in a quantitative manner, but as an indicator of some transient disorder, which as mentioned previously, is its primary function. An example of this may be found in the data from Appendix K, 7 June 1977, a scenario in which single path deep fade was simulated.

When DATEC was tested in conjunction with the DR8A radio, some adjustments to both the Eye Hits parameter thresholds and to the BEM hardware itself were required. The hardware changes are discussed in paragraph 6.1.3 of this section. The threshold changes were required for the same reason, higher system BER, to remain compatible with the level of performance of the communication system. Thresholds chosen for operation with this radio were 8.53 hits/sec and 136 hits/sec for amber and red, respectively. This is roughly equivalent to 10^{-7} and 10^{-5} error rates.

No System Simulation Scenarios were conducted that involved transient perturbations wherein fault detection and isolation might have been facilitated through use of the Eye Hits parameter.

AD-A051 926

HONEYWELL INC ST PETERSBURG FL AVIONICS DIV
ATEC DIGITAL ADAPTATION STUDY, DEVELOPMENT AND FIELD EVALUATION--ETC(U)
JAN 78 T J CAMPBELL, W F ACKER, C L CHRISTNER F30602-75-C-0282

F/G 17/2

UNCLASSIFIED

1077-14813-VOL-2

RADC-TR-77-431-VOL-2

NL

3 of 4
AD
A051926



BEST AVAILABLE COPY

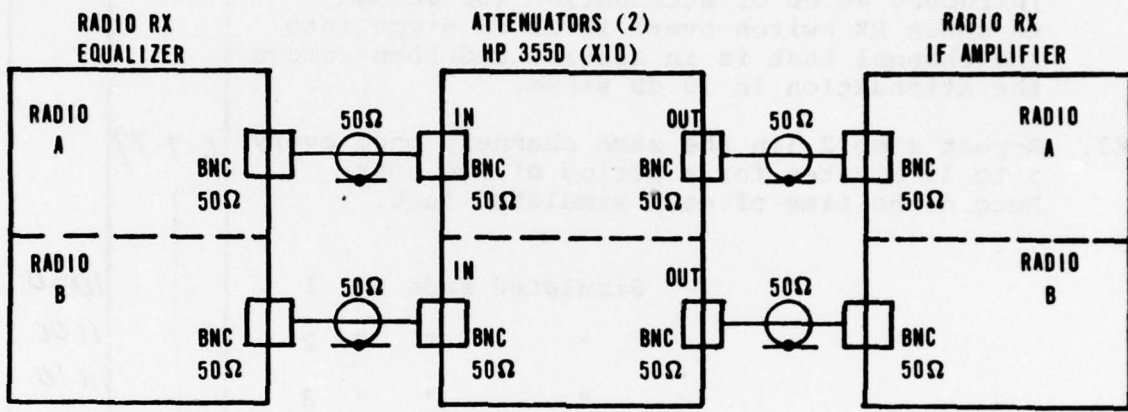

PROCEDURE	DATE	TIME
<p>K1. At HUA, connect attenuators (X10) between Equalizer and IF in RX A and RX B as shown in Figure K-1.</p> <p><u>Single Receiver Fade: -</u></p>	6-7-77	
<p>K2. In period of approximately 4 seconds: Introduce 40 dB of attenuation (or enough to cause RX switch over) in 10 dB steps into the channel that is in service and then remove the attenuation in 10 dB steps.</p>	6-7-77	
<p>K3. Repeat step 2 (In the same channel) once every 5 to 10 minutes for a period of one hour. Record the time of each simulated fade.</p>	6-7-77	
<p>Simulated Fade No. 1</p>		1050
<p>" " " 2</p>		1100
<p>" " " 3</p>		1110
<p>" " " 4</p>		1120
<p>" " " 5</p>		1130
<p>" " " 6</p>		1240
<p>" " " 7</p>		1250
<p>" " " 8</p>		1300
<p>" " " 9</p>		1310
<p>" " " 10</p>		1320
<p>" " " 11</p>		1330
<p>" " " 12</p>		1340
<p>BREAK FOR LUNCH MAINT. ADVISED TO CHECK A RX @ HUA</p>	<p>→</p>	
<p>CONDUCTED BY <u>C. L. Christy</u> 6-7-77</p> <p>OBSERVED BY _____</p>		<p>Y</p>



* Alternate attenuators which may be used:
Weinschel Engineering, Model 933

Figure K-1. Test Configuration, Link RF Fading

DATEC SYSTEM EVALUATION WORKSHEET

OBSERVANCE (key points only)	PRINTOUT REF (ATTACH)	DATE	TIME
System Clear		6/7	1020
Radio switched from "A" to "B" receiver, Link Performance print-out shows LINK eye hits on "A" Receiver only, Receiver "B" was good at all times, suspect problems on "A" receiver....	12/7	6/7	1100
Turned problem to maint		6/7	1130
Maint advs there is nothing wrong with the recvr, continuing to try and isolate the problem.. Still have problem with switching to "B" here at HUA...///RR			1320
Based upon Eye hits noted, squechles, and ESL margin drop noted on "A" recvr, during the past hour, believe the problem to be caused by single path fast fading, affecting only the "A" recvr..possibly interference of some kind. No other conclusions can be drawn ATT...///RR			1400
<p>Believe that if the hourly display could be held instead of being dumped into the daily data, after the end of each hour, the problem could have been isolated sooner...If we could arrange the system to only kick out the bottom scan on each parameter, into the daily readout, and keep all others, we would have much more info readily available to us...///RR ///</p>			
TECH CONTROLLER			
OBSERVED BY			

12/7

IQ-008

LINK PERFORMANCE ASSESSMENT - RADIOS

TIME 153/1140:32

		LAST SCAN	LAST HR MEAN	LAST 24 HR MEAN	LAST 24 HR DEV	LAST 30 DAYS MEAN	LAST 30 DAYS DEV	LAST 30 MINS MEAN	LAST 30 MINS DEV	
HUA	RSLMAR	29.936	26.676	29.142	1.1411	29.652	.21836	-----	-----	DB
A	EYEMAR	13.369	13.278	10.628	2.0067	10.989	2.3534	-----	-----	DB
	RSLAVL	1.0000	.92857	1.0000	-----	1.0000	-----	-----	-----	RATE
	EYEA VL	1.0000	1.0000	1.0000	-----	1.0000	-----	-----	-----	RATE
	EYEHIT	293.00	58.618	.72133	.05226	.04112	.04319	-----	-----	ZSC
HUA	RSLMAR	29.453	29.291	33.802	1.3026	30.284	2.0800	-----	-----	DB
B	EYEMAR	5.7603	9.7464	9.1157	1.9932	5.5974	2.3299	-----	-----	DB
	RSLAVL	1.0000	.92857	1.0000	-----	.98535	-----	-----	-----	RATE
	EYEA VL	1.0000	1.0000	1.0000	-----	0.9971	-----	-----	-----	RATE
	EYEHIT	0.0	52.013	.00125	.00219	4.5383	5.4634	-----	-----	ZSC
SBL	RSLMAR	38.500	39.102	37.585	.94111	39.237	1.2267	-----	-----	DB
A	EYEMAR	13.142	13.096	13.146	.44232	12.611	.51716	-----	-----	DB
	RSLAVL	1.0000	1.0000	1.0000	-----	1.0000	-----	-----	-----	RATE
	EYEA VL	1.0000	1.0000	1.0000	-----	0.9940	-----	-----	-----	RATE
	EYEHIT	0.0	0.0	.00155	.00347	3.7086	4.1931	-----	-----	ZSC
SBL	RSLMAR	32.333	32.365	33.788	1.0273	34.973	.73836	-----	-----	DB
B	EYEMAR	13.831	13.419	13.452	.31095	12.059	1.6250	-----	-----	DB
	RSLAVL	1.0000	1.0000	1.0000	-----	1.0000	-----	-----	-----	RATE
	EYEA VL	1.0000	1.0000	1.0000	-----	0.9941	-----	-----	-----	RATE
	EYEHIT	0.0	0.0	.00024	.00054	2.1079	3.6468	-----	-----	ZSC

Frame Error Rate (FER - Tl-4000 and TlWB1). Thresholds for this parameter were chosen in much the same manner as those for Eye Hits. With the communication system operating under normal conditions, no frame errors were detected from either multiplexer. The initial thresholds for frame error count (for both Tl-4000 and TlWB1) were selected as 2 errors per EPUT sample period for amber and 13 for red. This converts to frame error rates of 1.7×10^{-7} (amber) and 1.1×10^{-6} (red) for the Tl-4000; and 2.1×10^{-6} (amber) and 1.4×10^{-5} (red) for the TlWB1.

As with Eye Hits, FER was not used during the test scenarios in a strictly quantitative manner. The thresholds as they were set proved to be useful in fault detection and isolation and could be used as shown in the example below from an Appendix U scenario to catch a developing failure.

Note that the FER discrepancy at Sibyl was first recognized when it was actually in the order of 10^{-7} (see Tech Controller's comment at 0942, 8 June 1977, on page 327).

Since the thresholds were used in a more-or-less qualitative fashion, they were not changed from their initial values when the EPUT time base was changed from 2 minutes to 3-1/2 minutes, midway through the System Simulation Scenario test phase, as previously discussed in paragraph 6.1.3. The tech controllers continued to use the original limits and were just as effective in isolating faults.

Maintenance Voltage. The thresholds for Maintenance Voltages were set for in-plant tests at ± 5 percent from nominal for amber and ± 10 percent from nominal for red. At the start of field tests it was noted that all the voltages that were monitored (6 for each site) except one, the +15 volt power supply for the TlWB1 at Ft. Huachuca, were in the green (no alarm) condition and remained very stable. The TlWB1 +15 volt supply was amber. The equipment manual tolerance for this supply was the same as the DATEC amber tolerance, ± 5 percent. It was recognized prior to the start of field tests that it was not feasible to change the communication equipment power supplies incrementally to simulate gradual degradation. Power supplies were disabled completely for the tests either by removal of fuses or opening of circuit breakers. The point here is that analytically derived thresholds for Maintenance Voltage for field tests held little significance, and were in fact not required. For this reason, the tolerances originally chosen for in-plant tests were not changed for the field tests.

From examination of the field test data, it was noted that all power supplies with the exception of the TLWB1 supply previously mentioned were stable to well within 5 percent. The TLWB1 supply varied as much as 12 percent from nominal. No anomalies in operation of the low level MUX were noted which might have been correlated with the +15 volt power supply discrepancy, but as mentioned in previous paragraphs of this section, use of DATEC's long-term trend analyses capabilities was not a primary objective for the field tests; therefore, there may have been instances that were missed. The information for such a correlation to be made was available, nevertheless, on the Link Performance Assessment displays for the TLWB1 and for the Maintenance Voltages, and if examined over a period of time could have been used in making the decision to either retain the thresholds as originally established or perhaps loosen them.

6.1.15 The Recommended Sample Rates for the Most Effective Use of DATEC

In any discussion regarding monitoring of communication systems for the purposes of performance assessment, fault isolation, and trend analysis, the subject of scan time (or sample rate) is sure to evoke the most--and diverse--comment. Discussions with the tech controllers participating in the System Simulation Scenarios proved to be no exception. They all mentioned at one time or another that they felt scan times should be shorter. The merits of higher sample rates will be discussed subsequently, but some comment should be made at this point regarding the tech controllers' views and the circumstances involved during conduction of the scenarios that might have influenced their thinking with respect to this subject.

The System Simulation Scenarios were written and conducted in such a manner that their average duration was less than one hour. The perturbations that were introduced into the communication systems yielded realistic system responses, but as an expedient in getting as much data as possible, the faults were introduced over a period of minutes. Within 15 minutes to a half hour after the tech controllers had obtained their baseline data for an "all green" system operating in the normal manner, the perturbation(s) would be introduced. Except for a test such as that in Appendix S, Special RSL Long Term Test, long term performance assessment and trend analysis was not a part of the scenario objectives. These CPMAS functions were considered, but on a short term basis.

Essentially, then, the tech controllers were in a fault isolation mode from the outset of each scenario. It is quite natural that once a problem is recognized, it is desirable to get as much data as possible in the shortest period of time as possible, in order to isolate the cause and initiate remedial action. Electronic design has progressed to the point today where what we consider to be a reasonable period of time is "instantaneously".

To put the subject of scan time in its proper perspective, a scenario such as that in Appendix L--Receiver Noise Figure Degradation A versus B--should have been conducted such that the simulated degradation to the radio receiver took place over a period of days or even weeks. This would probably have come closer to simulating an anomaly created by an aging component, for instance. Since problems of this type do not cause loss of service--or for that matter even significantly degraded operation--immediately, present scan times might even be considered short.

It is acknowledged that scan times of three and one-half to four minutes for most parameters and seven to eight minutes for BEM processed eye parameters is lengthy if loss of service is involved. However, as was discussed in paragraph 6.1.4, loss

of service alarm information is processed separately from parameters via the SSFSS function, and is available to the operator within seconds of occurrence. Once the operator is alerted via the major alarm and associated minor alarms and two-state status information, he may then enter Monitor Immediate mode and examine parameters in the problem area with an update rate limited only by the hardware processor. For all parameters but two available in Monitor Immediate, this scan rate is just a few seconds. For FER and BEM processed Eye Hits data, the update times are three and one-half minutes and one and one-half minutes, respectively. These times are both established by EPUT sample time bases. (The BEM has a self-contained EPUT function dedicated to Hit counting.) The three and one-half minutes time base for the EPUT which processes frame errors was discussed in paragraph 6.1.3. That time base was changed from two minutes to three and one-half minutes during the Field Test program to match up better with the nodal control scan time to prevent loss of latched transient data. This time base should not be changed; however, a shorter time base for use during Monitor Immediate is a practical suggestion and is feasible. This applies to both the external EPUT and the EPUT function in the BEM. The shorter time bases could be mechanized by using the self-test time bases which are just seconds in duration.

As just stated, the EPUT time bases could be shortened for Monitor Immediate mode and thus improve the fault isolation function, but the DATEC system in its present configuration is not totally ineffective in this respect. Consider the test scenario of Appendix EE, Unrelated Multiple Failures-1, conducted on 29 June 1977. In this scenario 8, unrelated failures were induced in the communication system by perturbations introduced over a period of 34 minutes. The tech controllers isolated these faults in a period of 80 minutes--an average of 10 minutes per fault. Or, consider the data for this scenario conducted on 21 June, (see pages 305 through 310) when only four faults were induced. Total time to isolate these faults was 23 minutes--or between five and six minutes per fault.

UNRELATED MULTIPLE FAILURES - 1

PROCEDURE	DATE	TIME
EE1. AT SBL, INSERT 10 DB OF ATTENUATION IN THE A RECEIVER WAVE GUIDE ATTENUATOR	6/29	0838
EE2. AT SBL, INJECT ≈ 6 TI-4000 FRAME ERRORS EVERY 2-2 MINUTES USING THE FBEG. THIS IS TO BE DONE WITH THE NORMAL TI-4000 IN SERVICE.		0836
EE3. AT HUA, DISABLE THE NORMAL TI-4000 CHANNEL 7 XMIT CARD BY BREAKING THE CARD EDGE CONNECTIONS TO THE CARD WOST.		0852
EE4. AT HUA, REMOVE A SHORT CIRCUIT AT 20dB; INJECT INJECT $1000 \text{ Hz} \pm 10 \text{ Hz}$ AT 20 dBm.		0854
EE5. AT HUA, REMOVE THE CONN FUSE FROM THE TIWB1.		0841
EE6. UPON COMPLETION OF THIS TEST, RETURN ALL CONDITIONS TO NORMAL.		
EE6. AT HUA INSERT 40DB OF ATTENUATION IN THE RECEIVER A 70MHZ IF ATTENUATOR.		0843
EE7. AT HUA, INSERT 20 DB OF ATTENUATION IN THE TX WAVEGUIDE.		0844
EE8. UPON COMPLETION OF THE TEST, RETURN ALL CONDITIONS TO NORMAL.		
EE9. SHUT PATH WAVEGUIDE SWITCHES @ SBL @ 0910 ^{per-101} 0922 REQUESTED TO CHECK SWS ALIGNMENT @ 0840 REMOVED ATTENUATION @ 0845 REQUESTED TO XFER TO TXMIT @ SBL @ 0848 REQUESTED ANTENNA ALIGNMENT ON TX WAVE @ 0857 REMOVED LET @ 0858 REQUESTED CHECKOUT OF A 2'X @ HUA @ 0857 EE9 REQUESTED @ 0910		0910
CONDUCTED BY <u>Dr. Thomas Day</u>		
OBSERVED BY _____		

DATEC SYSTEM EVALUATION WORKSHEET

29 June 1977 Pg # 1

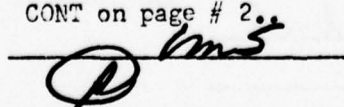
OBSERVANCE (key points only)	PRINTOUT REF (ATTACH)	DATE	TIME
Start new day with systems Green...///RR		6/29	0830
Overview showing the "A" radio recvr and TLWBL at SBL amber...///RR //Showing the "A" RSL at SBL down in the amber region...///RR	1/29 June 77		0840
Requested SBL chker their "A" Recvr antenna Alignment...///RR	1/29 June 77		0843
Overview now showing the "A" Recvr at HUA Red.. also showing a major alarm on the TLWBL's here and at SBL...Requesting in-house loops on the TLWBL's both at HUA and SBL...///RR			0844
Display now showing our "B" Recvr amber also..RR LP displays indicates RSL on both recvrs at HUA very low...///RR//Requesting SBL swap to their "B" radio xmitter...///RR	2/29 June 77		0845
Maint advsd the "A" Recvr antenna at SBL was out of alignment..They say this has been corrected...//RR			0848
SBL now on his "B" mitter ...///RR			0849
Display now showing low RSL on all four RECVERS (SBL and HUA)...///RR	SBL and 3/29 June 77		0851
Maint advs that SBL TLWBL is good,,, the one at HUA is bad and turned to maint ATT...///RR			0853
Maint advs of a blown fuse in the TLWBL here at HUA.. Replaced same...//RR			0854
Requesting SBL chker their Xmit antenna alignment...//RR			0856
SBL alignment good..Requesting HUA chk our xmit antenna alignment...Also requesting maint at HUA chk our "A" Recvr...///RR	3/29 June 77		0857
Maint at HUA advs our xmit antenna was misaligned.. This has been corrected...///RR			0900
Maint advs the "A" Recvr at HUA had bad IF amp.. Replaced same...//RR			0901
RSL's in both directions have stabilized, and are in the Green...///RR//Overview a gain showing a major alarm on both TLWBL's...///RR//Also showing a xmit chnl problem on our CY-104...///RR			0903
TECH CONTROLLER	CONT on page # 2..		
OBSERVED BY			

DATEC SYSTEM EVALUATION WORKSHEET 29 June 77 Pg # 2

OBSERVANCE (key points only)	PRINTOUT REF (ATTACH)	DATE	TIME
Cont from Pg # 1...///RR		6/29	0903
TLWBL's check good...Had maint swap chnl cards on the TL-4000 and the alarms on the TLWBL cleared.. maint chking cards ATT...///RR			0906
Gl display indicates hot levels from our sub, on the CY-104 chnl.....Requesting maint chker this out...///RR	4/29 June 77		0909
Overview now showing both Recvrs at HUA RFD Flagged... also showing our mux red (due probably to Recvrs..) Maint advsd of hot levels from sub on CY-104 and this has been corrected...///RR	5/29 June 77		0911
Telemetry down at SBL...///RR	5/29 June 77		0912
Displays indicating a problem with both Recvrs at HUA (voltages are good) but display says they are bad..Turned both to maint A TT...///RR			0916
Maint advs both Recvrs at HUA are Good...///RR			0918
Having maintnt at SBL chk out their Radio mitters...///RR	6/29 June 77		0919
Ma int advs SBL has had a pwr flop...///RR			0921
Maint advs SBL back up ATT..They went down at 0910...///RR			0922
A ll major and hard alarms cleared...only parameter alarms remain..waiting for display to update...///RR			0926
Due to low eye margin, requesting maint at HUA chk our "B" ra dio recvr...///RR	6/29 June 77		0930
Maint says the "B" recvr good...///RR			0931
Parameter alarms at HUA have clared...Rema ing are parameter alarms at SBL...waiting for display updates...///RR			0934
Due to eye hits on the "A" recvr at SBL, requesting they lock on their "B" radio recvr...Also requesting they but their "A" radio mitter back in service...///RR	7/29 June 77		0942
LS display indicating our Eye amplitude on the "A " recv in the Red...///RR	7/29 June 77		0944
Requesting SBL go back to "E" radio mitter and check their "A" transceiver...///RR			0947
CONT on pg # 3			
TECH CONTROLLER _____	<i>cm5</i>		
OBSERVED BY _____	<i>P</i>		

OBSERVANCE (key points only)	PRINTOUT REF (ATTACH)	DATE	TIME
Cont from pg # 2..//RR (good) Maint advs the "A" transceiver at SEL ..They also advs that eye hits at SBL caused by xmit baseband problem at HUA.. Honeywell now taking control to trblshoot an apparent problem at SEL..//RR		6/29	0947 0956
<hr/> Problems isolated to:			
<ol style="list-style-type: none"> 1. Transmit baseband problem at HUA. 2. "A" recvr antenna alignment at SBL. 3. Blown fuse in TLWBL at HUA 4. Xmit antenna at HUA misaligned. 5. Bad IF a mp in "A" recvr at HUA. 6. Hot customer levels on CY-104 at HUA. 7. Pwr flop at SEL. 8. Bad chnl cards on TL-4000 at HUA. 			
Displays used..			
<ol style="list-style-type: none"> 1. Lp-1 2. Ls-1 3. Overview (for problem indicator.) 			
TECH CONTROLLER <u> CMS </u>			
OBSERVED BY <u> (P) </u>			

#2
29 June 77

IQ-006

SYSTEM OVERVIEW

TIME 180703:14:11

	HUA	SBL
RADIO A	.RS<	>IA.
B	.AI<	.
MUX SW	.	.
A	.	>IA.
B	.	.
CY104	.	.
	.	.
	.	.
	.	.
	.	.
T1WB1	.R01<><>01R.	.
	.	.

MAJOR ALARM

TELEMETRY.

SITE
AS-1

		LINK PERFORMANCE ASSESSMENT - RADIOS				TIME 180703:14:55
	LAST SCAN	LAST HR MEAN	LAST 24 HR MEAN	LAST 30 DAYS DEV	LAST 30 MINS MEAN	DEV
HUA	RSLMAR-2.6322	-2.6322	33.443	0.0	-----	DB
A	EYEMAR 13.023	13.028	13.401	0.0	-----	DB
	RSLAVL 0.0	0.0	1.0000	-----	-----	RATE
	EYEA VL 1.0000	1.0000	1.0000	-----	-----	RATE
	EYEHIT 0.0	0.0	0.0000	0.0	-----	%SC
HUA	RSLMAR 11.382	11.382	23.813	0.0	-----	DB
B	EYEMAR 7.2400	6.0731	-----	-----	-----	DB
	RSLAVL 1.0000	1.0000	0.9375	-----	-----	RATE
	EYEA VL 1.0000	1.0000	-----	-----	-----	RATE
	EYEHIT 0.0	0.0000	-----	-----	-----	%SC
SBL	RSLMAR 28.917	28.917	38.425	0.0	-----	DB
A	EYEMAR 11.672	12.191	-----	-----	-----	DB
	RSLAVL 1.0000	1.0000	1.0000	-----	-----	RATE
	EYEA VL 1.0000	1.0000	-----	-----	-----	RATE
	EYEHIT 0.0	0.0	-----	-----	-----	%SC
SBL	RSLMAR 36.111	36.111	36.076	0.0	-----	DB
B	EYEMAR 12.346	12.638	-----	-----	-----	DB
	RSLAVL 1.0000	1.0000	1.0000	-----	-----	RATE
	EYEA VL 1.0000	1.0000	-----	-----	-----	RATE
	EYEHIT 259.45	41.350	-----	-----	-----	%SC

#3
29 June 77

III 12>ZLN=t LINK PERFORMANCE ASSESSMENT - RADIOS TIME 13/0350:14

		LINK PERFORMANCE ASSESSMENT - RADIOS				MAJOR ALARM			
		LAST 24 HR	LAST 24 HR	LAST 24 HR	LAST 3 DAYS	LAST 3 DAYS	LAST 3 DAYS	LAST 3 DAYS	
		SCAN	MEAN	MEAN	MEAN	DEV	MEAN	DEV	
HUA	RSLMAR	-2.6322	-2.6322	33.443	0.0	-----	-----	-----	DB
A	EYEMAR	13.023	13.023	13.471	0.0	-----	-----	-----	DB
	RSLAVL	0.0	0.0	1.0000	-----	-----	-----	-----	RATE
	EYEA VL	1.0000	1.0000	1.0000	-----	-----	-----	-----	RATE
	EYEHIT	0.0	0.0	0.0000	0.0	-----	-----	-----	/SC
HUA	RSLMAR	11.382	11.382	23.813	0.0	-----	-----	-----	DB
B	EYEMAR	7.2401	6.0731	-----	-----	-----	-----	-----	DB
	RSLAVL	1.0000	1.0000	0.93750	-----	-----	-----	-----	RATE
	EYEA VL	1.0000	1.0000	-----	-----	-----	-----	-----	RATE
	EYEHIT	0.0	0.0000	-----	-----	-----	-----	-----	/SC
SBL	RSLMAR	19.989	24.403	33.425	0.0	-----	-----	-----	DB
A	EYEMAR	11.781	11.781	12.191	0.0	-----	-----	-----	DB
	RSLAVL	1.0000	1.0000	1.0000	-----	-----	-----	-----	RATE
	EYEA VL	1.0000	1.0000	1.0000	-----	-----	-----	-----	RATE
	EYEHIT	0.29333	0.29333	0.0	0.0	-----	-----	-----	/SC
SBL	RSLMAR	16.667	26.389	36.076	0.0	-----	-----	-----	DB
B	EYEMAR	12.346	12.630	-----	-----	-----	-----	-----	DB
	RSLAVL	1.0000	1.0000	1.0000	-----	-----	-----	-----	RATE
	EYEA VL	1.0000	1.0000	-----	-----	-----	-----	-----	RATE
	EYEHIT	289.45	41.350	-----	-----	-----	-----	-----	/SC

IQ-007

LINK STATUS TIME 19/0357:01

		LINK STATUS		RADIO	
	TI-4000.....	RADIO.....	
		HUA	SBL	HUA	SBL
ALARM	SW MAJOR
	SW MINOR
	MAJOR
STATUS	TX IN SVC	A	A	A	B
	RX IN SVC	A	A	B	A
	MAINT
PARAMETER	FER	<4.9E-3	0.00162 R	.	.
	CRFRM	.	*	.	.
	BER COR	NO DATA	0.0015 R	.	.
				RX SQUELCH	.
				RSL MARGIN	9.7500 R. 12.000 R
				EYE MARGIN	5.7600 . 11.781
				EYE AMPL	-11.286 ? -5.0077
				EYE HITS	0.0 . 0.29333 A
				DER BER	9.3E-10 . 1.3E-12

PAGE 1

#45
29 June 77

!

130/0908

130/0908 MT.NO=00 MODE=00

CY-104...HUA...CH'S..1&13

RH AV-03.1 TT 180/0908 0005
AV-03.1RH FR+0097 CN-56.4 SN+53.3 WF-55.4 HD+52.6
VH-03.1 PA+00.0 M1+00.2 M5+00.0 FR+0097 SN+007.0

SPECTRUM 6---5---4---3---2---1---0---1

01 -66.8
02 -80.1
03 -87.1
04 -84.1
05 -87.1
06 -73.0
07 -63.0
08 -50.1*****
09 -08.8*****
10 -03.1*****
11 -09.5*****
12 -51.1*****

180/0908 MT.NO=00 MODE=00

!

#5 29 June 77

```
MAC-3-07-12          SYSTEM OVERVIEW          TIME 18070939:
HUA                   SBL
RADIO A               .RS<                .
                   .RI<                .
MUX SW B              .R<>                .
A                     .R<>                >IA.
B                     .
CY104                 .A01>               .
                   .
                   .
                   .
                   .
                   .
                   .
                   .
                   .
                   .
T1WB1                 .R01<> >01A.
                   .
                   .
.....
TELEMETRY.           .
SITE                 .
```

```
MAC-3-13-17         SYSTEM OVERVIEW          TIME 18070911:49
HUA                   SBL
RADIO A               .RS<                .
                   .RI<                .
MUX SW B              .R<>                .
A                     .R<>                >IA.
B                     .R<>                .
CY104                 .A01>               .
                   .
                   .
                   .
                   .
                   .
                   .
                   .
                   .
                   .
T1WB1                 .R01<> >01A.
                   .
                   .
.....
TELEMETRY.           .
SITE                 .
```

#6
29 June 77

IQ-008

LINK PERFORMANCE ASSESSMENT - RADIOS TIME 180/0919:20
MAJOR ALARM

	LAST SCAN	LAST HR MEAN	LAST 24 HR MEAN	DEV	LAST 30 DAYS MEAN	DEV	LAST 30 MTHS MEAN	DEV	
HUA	RSLMAR-9.0000	2.3955	33.443	0.0	-----	-----	-----	-----	DB
A	EYEMAR 13.023	13.028	13.401	0.0	-----	-----	-----	-----	DB
	RSLAVL 0.0	.20000	1.0000	-----	-----	-----	-----	-----	RATE
	EYEA VL 1.0000	1.0000	1.0000	-----	-----	-----	-----	-----	RATE
	EYEHIT 0.0	0.0	.00883	0.0	-----	-----	-----	-----	/SC
HUA	RSLMAR-9.0000	10.428	28.813	0.0	-----	-----	-----	-----	DB
B	EYEMAR-29.100	-5.0628	6.0731	0.0	-----	-----	-----	-----	DB
	RSLAVL 0.0	.80000	.93750	-----	-----	-----	-----	-----	RATE
	EYEA VL 0.0	.66667	1.0000	-----	-----	-----	-----	-----	RATE
	EYEHIT 0.0	0.0	.08390	0.0	-----	-----	-----	-----	/SC
SBL	RSLMAR 39.000	31.701	38.425	0.0	-----	-----	-----	-----	DB
A	EYEMAR 11.781	11.781	12.191	0.0	-----	-----	-----	-----	DB
	RSLAVL 1.0000	1.0000	1.0000	-----	-----	-----	-----	-----	RATE
	EYEA VL 1.0000	1.0000	1.0000	-----	-----	-----	-----	-----	RATE
	EYEHIT .29333	.29333	0.0	0.0	-----	-----	-----	-----	/SC
SBL	RSLMAR 36.111	31.333	36.076	0.0	-----	-----	-----	-----	DB
B	EYEMAR 13.028	13.028	12.633	0.0	-----	-----	-----	-----	DB
	RSLAVL 1.0000	1.0000	1.0000	-----	-----	-----	-----	-----	RATE
	EYEA VL 1.0000	1.0000	1.0000	-----	-----	-----	-----	-----	RATE
	EYEHIT 289.45	41.350	-----	-----	-----	-----	-----	-----	/SC

MAC-1-07-12

LINK PERFORMANCE ASSESSMENT - RADIOS TIME 180/0930:32

	LAST SCAN	LAST HR MEAN	LAST 24 HR MEAN	DEV	LAST 30 DAYS MEAN	DEV	LAST 30 MTHS MEAN	DEV	
HUA	RSLMAR 32.340	10.937	33.443	0.0	-----	-----	-----	-----	DB
A	EYEMAR 15.254	14.141	13.401	0.0	-----	-----	-----	-----	DB
	RSLAVL 1.0000	.42857	1.0000	-----	-----	-----	-----	-----	RATE
	EYEA VL 1.0000	1.0000	1.0000	-----	-----	-----	-----	-----	RATE
	EYEHIT 0.0	0.0	.00883	0.0	-----	-----	-----	-----	/SC
HUA	RSLMAR 30.033	16.029	28.813	0.0	-----	-----	-----	-----	DB
B	EYEMAR-29.100	-5.0628	6.0731	0.0	-----	-----	-----	-----	DB
	RSLAVL 1.0000	.85714	.93750	-----	-----	-----	-----	-----	RATE
	EYEA VL 0.0	.66667	1.0000	-----	-----	-----	-----	-----	RATE
	EYEHIT 0.0	0.0	.08390	0.0	-----	-----	-----	-----	/SC
SBL	RSLMAR 38.400	33.041	38.425	0.0	-----	-----	-----	-----	DB
A	EYEMAR 12.346	12.064	12.191	0.0	-----	-----	-----	-----	DB
	RSLAVL 1.0000	1.0000	1.0000	-----	-----	-----	-----	-----	RATE
	EYEA VL 1.0000	1.0000	1.0000	-----	-----	-----	-----	-----	RATE
	EYEHIT 364.00	132.19	0.0	0.0	-----	-----	-----	-----	/SC
SBL	RSLMAR 36.111	32.289	36.076	0.0	-----	-----	-----	-----	DB
B	EYEMAR 12.000	12.014	12.633	0.0	-----	-----	-----	-----	DB
	RSLAVL 1.0000	1.0000	1.0000	-----	-----	-----	-----	-----	RATE
	EYEA VL 1.0000	1.0000	1.0000	-----	-----	-----	-----	-----	RATE
	EYEHIT 289.45	41.350	-----	-----	-----	-----	-----	-----	/SC

#7
29 June 77

FROM MAC-qAC-		LINK PERFORMANCE ASSESSMENT - RADIOS								TIME
		LAST SCAN	LAST HR MEAN	LAST 24 HR MEAN	24 HR DEV	LAST 30 DAYS MEAN	30 DAYS DEV	LAST 30 DAYS MEAN	30 DAYS DEV	
HUA	RSLMAR	32.240	32.240	23.521	9.9216					DB
A	EYEMAR	15.254	14.141	13.401	0.0					DB
	RSLAVL	1.0000	1.0000	.33333						RATE
	EYEA VL	1.0000	1.0000	1.0000						RATE
	EYEHIT	0.0	0.0	.00000	0.0					/SC
HUA	RSLMAR	22.957	22.957	23.297	5.5167					DB
B	EYEMAR	3.0472	-1.7851	6.0731	0.0					DB
	RSLAVL	1.0000	1.0000	.01667						RATE
	EYEA VL	1.0000	.75000	1.0000						RATE
	EYEHIT	0.0	1.0	.00000	0.0					/SC
SBL	RSLMAR	33.700	33.004	33.425	0.0					DB
A	EYEMAR	12.346	12.004	12.191	0.0					DB
	RSLAVL	1.0000	1.0000	1.0000						RATE
	EYEA VL	1.0000	1.0000	1.0000						RATE
	EYEHIT	364.02	102.19	0.0	0.0					/SC
SBL	RSLMAR	35.033	32.000	36.076	0.0					DB
B	EYEMAR	13.362	13.066	12.639	0.0					DB
	RSLAVL	1.0000	1.0000	1.0000						RATE
	EYEA VL	1.0000	1.0000	1.0000						RATE
	EYEHIT	0.0	0.0	41.350	0.0					/SC

MAC-3-01-06

		LINK STATUS		TIME 180/0944:00	
	T1-4000.....	RADIO.....	
		HUA	SBL	HUA	SBL
ALARM	SW MAJOR	.	.		
	SW MINOR	.	.		
	MAJOR	.	.		
STATUS	TX IN SVC	A	A	A	A
	RX IN SVC	A	A	A	B
	MAINT
PARAMETER	FER	<4.9E-3	.00127 R		
	CRFRM	.	*		
	BER COR	NO DATA	.INVL		
				RX SQUELCH	
				RSL MARGIN	32.240 . 35.033
				EYE MARGIN	15.254 . 13.362
				EYE ANPL	-11.048 R.-0.0077
				EYE HITS	0.0 . 0.0
				BER BER	1.2E-14 . 6.2E-13

6.1.16 The Communication System Operations During Degraded/
Normal Operating Conditions of the DATEC System

Appendix J of the Field Test Plan/Procedures document addressed this item specifically. All DATEC monitor point connections to the communication system are either to relay contacts which are provided for this purpose or are effectively bridge-on type connections. In the latter case, to assure that in the event the active monitoring circuits in DATEC should short to ground for some reason, isolation resistors are provided to limit current to a value which will not degrade the operation of the communication system. The procedures of Appendix J verified the fail-safe aspects of monitor circuits falling into this latter category. Results of these tests indicated that when simulated failures were made to occur in the various monitoring functions of DATEC, the communication system continued to operate without alarm or degradation.

Normal operation of the communication system prior to degrading the DATEC system (i.e., normal operating conditions of the DATEC system) was verified during the initial steps of Appendix J.

The procedure and data collected during this field test is included on pages 429 through 453 following.

APPENDIX J

OPERATION WITH DEGRADED CONDITIONS

1. PURPOSE

The purpose of this test is two-fold: (1) to demonstrate what effect, if any, a degraded DATEC System has on a normally operating communication system, and (2) to demonstrate operation of the DATEC system when both DATEC and communication system are in degraded condition.

2. BACKGROUND

All DATEC connections, with the exception of power supply voltages, Baseband Eye Monitor (BEM) Couplers and Event Per Unit Time (EPUT) Remote Buffers, are to relay contacts in the communication system. No adverse effects can be caused by DATEC degraded operation for relay contact monitoring, therefore; the first part of this test will address only the active signals monitored by DATEC to demonstrate what effect on a normally operating communication system, degradation of DATEC will have.

All power supply voltages are monitored through a series resistance. In those cases where scaling is required, there is also a shunt resistor forming a voltage divider. Failure will be simulated by shorting the monitored side of the series resistor to ground.

The baseband Eye Monitor connection is to the AN/FRC-162 RCV LO LVL output via the Baseband Active Coupler. Failure will be simulated by removal of power from the Coupler.

EPUT Remote Buffers connect directly to T1-4000 and T1WB1 logic signals. The buffers present a minimum impedance of 10,000 ohms. Failure will be simulated by removal of power from the Buffer.

The second phase of this test will deal with situations wherein both the communication system and DATEC are degraded.

Because of the complexity involved, the most likely candidate for DATEC degradation/failure is the nodal control function consisting of the ADDS console, H-316R computer and Disc. Failure in this area eliminates the facility of automatically scanning and displaying (via CRT) site status. However, there are several ways (work-around-methods) of collecting and displaying data which may be employed while repair work is being done on the nodal controller. Although the automatic collection and display of alarms via the nodal controller has been lost, the SSFSS is fully operative. Local hardware display

of both nodal and remote alarms will be demonstrated. Use of the MAC in the local mode and use of the TermiNet printer patched into the 150 Baud party line to control and collect/display data via the Measurement and Acquisition Control (MAC) will be demonstrated.

If the EPUT fails, there is no backup mode; therefore, data such as BEM parameters, T1-4000 and T1WB1 frame errors and reframes, and radio receiver squelch information will be lost. However, the EPUTS have a local self-test function and modular construction which will provide quick fault isolation and repair capability.

If a BEM fails, baseband quality data (Dispersion, Hits and Eye Amplitude voltages) for the radio involved will be lost; however, the basic fault detection/isolation indications such as alarms and the remaining equipment parameters are intact.

Failure of an Alarm Scanner means that part or all of the hard equipment alarms and two-state status indication for that particular scanner is lost, but the PATE can still analyze parameter data and display alarm threshold violations. Local self-test and modular construction facilitate fault isolation/repair.

Loss of an Analog Scanner means that part or all of the voltage measurements routed via that scanner will be lost, but hard equipment alarms and two-state status information is still available. Like the Alarm Scanner and EPUT, local self-test and modular construction facilitates fault isolation/repair.

If a MAC fails, remote automatic parameter scanning capability is lost, but via Analog Scanner local control, the voltage(s) to be monitored may be selected and are available at the measurement bus jacks of the Jack Panels. Also BEM Dispersion voltage and Eye Amplitude are available at the front panel of the BEM. Demonstration of the former will be made during the test.

If the Master Alarm Display (MAD) is inoperative, no alarm or two-state status information is available to the PATE (from either site), and therefore CRT display of this data is lost. However, alarm/two-state status information may be observed locally at each site on the Alarm Scanners, and this information (for both sites) is displayed at the nodal Alarm Displays, as will be demonstrated during the test.

Finally, failure of the modems used for telemetry will be considered. Tests will show retention of fault detection/isolation capability even though one of the two modems is lost. First, the 150 baud unit will be removed and fault detection/isolation will be illustrated using only hard equipment alarm/two-state status information. Then, with only the 75 Baud unit disabled, fault detection/isolation will be demonstrated using parameter information conveyed via the 150 Baud modem.

3. OBJECTIVE

The objective of this test is to demonstrate that degraded conditions of the DATEC equipment will not interfere with normal operation of the communication equipment; and further, that even though in a degraded state, it is possible to use DATEC to fault detect and isolate degradation of the communication system.

PROCEDURE	REQUIREMENT	TOLERANCE	PASS	FAIL
J1. Verify that link status is normal (i.e., no equipment alarms; no perturbations being introduced).	All communication equipment indications normal	---	✓	
J2. At ADDS, enter NC, SN. After 9 minutes observe SYSTEM OVERVIEW.	No alarms at DATEC Alarm Scanners, Alarm Displays or MAD. No alarms	---	✓	
J3. At ADDS, enter NC, LS, 1, 1. Observe LINK STATUS, PAGE 1.	No alarms; all parameters in green flag range.	---	✓	
J4. At ADDS, enter NC, LS, 1, 2. Observe LINK STATUS, PAGE 2.	No alarms; all parameters in green flag range.	---	✓	
J5. At ADDS, enter NC, MV, HUA. Observe MAINTENANCE VOLTAGES-HUA. Record the value of the TLWB1 +15 Vdc displayed.	All voltages normal; flag status green (G). NOTE: TLWB1 +15V MAINT VOL. READS 16.7 (R) - THIS IS OUT-OF-TOL BECAUSE THE TLWB1 SUPPLY ITSELF IS HIGH. SEE NOTE IN STEP 7 BELOW.	---	✓	
J6. At ADDS, enter NC, MV, SBL. Observe MAINTENANCE VOLTAGES-SBL.	All voltages normal; flag status green (G)	---	✓	
J7. At HUA EPUT, connect a jumper wire from TBL-81 to TBL-83, and a DVM to read TLWB1 +15 Vdc. (High to TBL-84; low to TBL-83)	DVM reads +15 Vdc 16.64 V. Note: TLWB1 +15 VOLT POWER SUPPLY IS OUT-OF-TOLERANCE SHOULD BE +15±0.75 VOLTS CJC	+1 V	✓	
J8. At ADDS, enter NC, SN. Wait 5 minutes; observe SYSTEM OVERVIEW.	No alarms in TLWB1 field	---	✓	
<u>TEST ACCEPTANCE</u>				
HONEYWELL		DATE		
GOVERNMENT		DATE		

J3

IQ-007

LINK STATUS
.....T1-4000.....
HUA SBL

TIME 001/0122:53
.....RADIO.....
HUA SBL

ALARM

SW MAJOR
SW MINOR
MAJOR

.
.
.

TX PROB
RX PROB

.
.
.

STATUS

TX IN SVC
RX IN SVC
MAINT

A
A
.

A
A
.

TX IN SVC
RX IN SVC
MAINT

A
A
.

A
A
.

PARAMETER

FER
CRFRM

5.3E-7

. 1.0E-15

BER COR DIF

5.1913

.-2.1335

RX SQUELCH
RSL MARGIN
EYE MARGIN
EYE AMPL
EYE HITS
DER BER

37.462
10.679
-7.0982
0.0
5.0E-12

. 39.500
. 13.482
.-9.0741
. 0.0
. 1.4E-13

PAGE 1

J4

IQ-008

LINK STATUS
.....CY-104.....
HUA SBL

TIME 001/0123:35
.....T1WB1.....
HUA SBL

ALARM SERVICE

REMOTE

STATUS MAINT

PARAMETER CHANNEL

SITE ALARMS
ENTRY
FIRE
AC PWR
BATTERY
W.A. PR
W.G. HV
FL(X)D

OFFICE

MAINT

FER 1.2E-14 1.2E-14
REFRAME

PAGE 2

J5

AS-1

MAINTENANCE VOLTAGES - HUA

TIME 001/0124:09

NO.	NAME	VOLTS	C	RH	AH	CG	AL	RL	MEAN	DEV	INITIAL DATE
01	TIWB1+15	16.7	R	16.5	15.7	15.0	14.2	13.5			
02	TIWB1+12	12.4	G	13.2	12.6	12.0	11.4	10.8			
03	T14000+5	4.90	G	5.50	5.25	5.00	4.75	4.50			
04	T14000-6	-6.08	G	-5.40	-5.70	-6.00	-6.30	-6.60			
05	RADIO+24	24.0	G	26.4	25.2	24.0	22.8	21.6			
06	RADIO-20	-19.9	G	-18.0	-19.0	-20.0	-21.0	-22.0			

J-6

MAC-3-07-12

MAINTENANCE VOLTAGES - SBL

TIME 001/0125:09

NO.	NAME	VOLTS	C	RH	AH	CG	AL	RL	MEAN	DEV	INITIAL	DATE
01	TIWBI+15	15.1	G	16.5	15.7	15.0	14.2	13.5				
02	TIWBI+12	12.3	G	13.2	12.6	12.0	11.4	10.8				
03	TI4000+5	4.94	G	5.50	5.25	5.00	4.75	4.50				
04	TI4000-6	-6.03	G	-5.40	-5.70	-6.00	-6.30	-6.60				
05	RADIO+24	24.1	G	26.4	25.2	24.0	22.8	21.6				
06	RADIO-20	-20.1	G	-18.0	-19.0	-20.0	-21.0	-22.0				

J-8

BEM-1-M0-12

SYSTEM OVERVIEW

TIME 001/0128:30

RADIO A
B
MUX SW
A
B
CY104

HJA

SBL

TIWB1

TELEMETRY

SITE

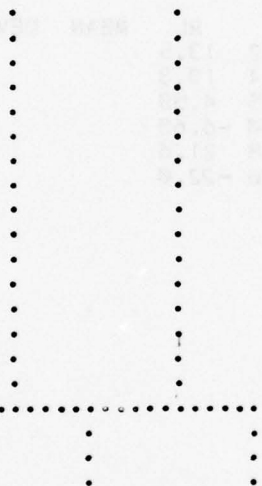

PROCEDURE	REQUIREMENT	TOLERANCE	PASS	FAIL
J9. At ADDS, enter NC, LS, 1, 2. Observe LINK STATUS, PAGE 2.	No alarms in TLWB1 field	---	✓	
J10. At ADDS, enter NC, MV, HUA Observe MAINTENANCE VOLTAGES HUA	In TLWB1 +15 Vdc field: $\frac{\text{VALUE}}{0.0} \frac{C}{R}$	+0.2 V	✓	
J11. Remove jumper wire installed in step 7.	---	---	---	
J12. After determining which radio is in-service at HUA, remove power to the Baseband Active Coupler in that channel.	---	---	---	
J13. At ADDS, enter NC, SN. When EPUT-1-0 appears in upper left corner of CRT display, interrupt scan and enter NC, LS, 1, 1. Observe LINK STATUS, PAGE 1. Also, note condition of the TL-4000 channel in service.	No equipment or parameter alarms in TL-4000 field of LINK STATUS, PAGE 1. Front panel indications of in-service TL-4000 are normal	---	✓	
J14. Restore power to Baseband Active Coupler.	---	---	---	
J15. At HUA remove power from EPUT Buffer Boxes, #1, #2 and #4.	---	---	---	
<u>TEST ACCEPTANCE</u>				
HONEYWELL		DATE		
GOVERNMENT		DATE		

J-9

MAC-3-01-06

LINK STATUS
.....CY-104.....
HUA SBL

TIME 001/0129:41
.....TIWBI.....
HUA SBL

ALARM SERVICE

OFFICE

REMOTE

STATUS

MAINT

MAINT

PARAMETER

CHANNEL

FER 1.2E-14 . 1.2E-14
REFRAME

SITE ALARMS

ENTRY
FIRE
AC PWR
BATTERY
W.A. PR
W.G. HV
FLOOD

PAGE 2

J-10

MAC-1-18-23

MAINTENANCE VOLTAGES - HUA

TIME 001/0131:33

NO.	NAME	VOLTS	C	RH	AH	CG	AL	RL	MEAN	DEV	INITIAL	DATE
01	T1WB1+15	0	R	16.5	15.7	15.0	14.2	13.5				
02	T1WB1+12	12.4	G	13.2	12.6	12.0	11.4	10.8				
03	T14000+5	4.96	G	5.50	5.25	5.00	4.75	4.50				
04	T14000-6	-6.08	G	-5.40	-5.70	-6.00	-6.30	-6.60				
05	RADIO+24	24.0	G	26.4	25.2	24.0	22.8	21.6				
06	RADIO-20	-19.9	G	-18.0	-19.0	-20.0	-21.0	-22.0				

213

MAC-3-01-06

LINK STATUS
.....T1-4000.....
HUA SBL

TIME 001/0145:20
.....RADIO.....
HUA SBL

ALARM	SW MAJOR	.	.	TX PROB	.	.
	SW MINOR	.	.	RX PROB	.	.
	MAJOR
STATUS	TX IN SVC	A	.	TX IN SVC	A	.
	RX IN SVC	A	.	RX IN SVC	A	.
	MAINT	.	.	MAINT	.	.
PARAMETER	FER	1.0E-15	.	RX SQUELCH	.	.
	CRFRM	.	.	RSL MARGIN	37.337	.
				EYE MARGIN	15.290	.
	BER COR DIF	1.9E-6	.	EYE AMPL	-17.000	.
				EYE HITS	0.0	.
				DER BER	1.0E-15	.
						2.2E-13

PAGE 1

PROCEDURE	REQUIREMENT	TOLERANCE	PASS	FAIL
<p>J16. At ADDS, enter NC, SN. When EPUT-1-0 appears in upper left corner of CRT display, interrupt scan and enter NC, LS, 1, 1. Observe LINK STATUS, PAGE 1. Also note condition of the Tl-4000 channel in service.</p>	<p>No equipment alarms in Tl-4000 field of LINK STATUS, PAGE 1. Front panel indications of in-service Tl-4000 are normal</p>	---	✓	
<p>J17. At ADDS, enter NC, LS, 1, 2. Observe LINK STATUS, PAGE 2. Also note condition of TLWBL</p>	<p>No OFFICE alarm in TLWBL field of LINK STATUS, PAGE 2. Front panel indications of TLWBL are normal</p>	---	✓	
<p>J18. Restore power to HUA EPUT Buffer Boxes.</p>	---	---	---	---
<p>J19. At HUA, perform the following steps:</p> <ul style="list-style-type: none"> • Turn ADDS console power OFF. • Place H-316R MA-SI-RUN switch in SI (center) position. • At PATE Jack Panel, connect patch cords between "TN" and "232" (top and bottom row of jacks); between "188" on top row and "MAC" on bottom row; 	---	---	---	---
TEST ACCEPTANCE				
HONEYWELL				DATE
GOVERNMENT				DATE

J-17

MAC-3-01-06

LINK STATUS
.....CY-104.....
HUA SBL

TIME 001/0200:17
.....TIWBI.....
HUA SBL

ALARM SERVICE

REMOTE

STATUS MAINT

PARAMETER CHANNEL

SITE ALARMS
ENTRY
FIRE
AC PWR
BATTERY
W.A. PR
W.G. HV
FL(X)D

OFFICE

MAINT

FER 2.2E-6
REFRAME * 1.2E-14

PAGE 2

PROCEDURE	REQUIREMENT	TOLERANCE	PASS	FAIL
<p>J19. (Cont'd)</p> <p>and between "MAC" on top row and "188" on bottom row.</p>	<p>At HUA note the following: Audible alarm actuates SBL Alarm Display - • TIWBI LED (blinking) • MAJOR ALARM lamp ON • ALARM lamp ON • NON ACK lamp ON MAD (Alarm Scanner Column 2) - • MAJOR ALARM lamp ON • ALARM lamp ON • NON ACK lamp ON</p>	<p>--- --- --- --- --- --- ---</p>	<p>✓ ✓ ✓ ✓ ✓ ✓ ✓</p>	
<p>J20. At SBL pull CONV fuse from TIWBI</p>				
<p>J21. Turn HUA MAD POWER switch OFF</p>	<p>Audible alarm still operating All SBL Alarm Display indications remain as in step 20.</p>	<p>---</p>	<p>---</p>	<p>---</p>
<p>J22. Turn HUA MAD POWER switch ON.</p>		<p>---</p>	<p>---</p>	<p>---</p>
<p>J23. Turn audible alarm off; momentarily depress ACK pushbutton on SBL Alarm Display</p>		<p>---</p>	<p>---</p>	<p>---</p>
<p>TEST ACCEPTANCE -</p>				
<p>HONEYWELL</p>				<p>DATE</p>
<p>GOVERNMENT</p>				<p>DATE</p>

PROCEDURE	REQUIREMENT	TOLERANCE	PASS	FAIL
<p>J24. At TermiNet printer, verify that unit is ON LINE, Rate switch is set to LOW, Rate Transparency is OFF; then at keyboard enter:</p> <p>Control S 3 D 1 / 1 8 / 1 9 / G</p>	<p>Terminet prints: 0018 0 V 0019 0 V</p>	<p>+0.2 V ±0.2 V</p>	<p>✓ ✓</p>	
<p>J25. At SBL, replace CONV fuse in TLWB1</p>	<p>---</p>	<p>---</p>	<p>---</p>	<p>---</p>
<p>J26. At the SBL MAC panel:</p> <ul style="list-style-type: none"> Place MAC CONTROL SELECT switch to the left (PANEL ONLY) position Under SCANNER CONTROL, depress CONNECT push-button switch and set in an ADDRESS of 18. 	<p>MAC ANALOG MEASUREMENT reads +07.500 VOLTS lamp ON</p> <p>1152</p>	<p>+0.5 V ---</p>	<p>✓ ✓</p>	<p>---</p>
<p><u>TEST ACCEPTANCE</u></p>				
<p>HONEYWELL _____ DATE</p>				
<p>GOVERNMENT _____ DATE</p>				

J-24

3D1/18/19\G
0018 +00.032V
0019 +00.031V \~

J-29
5/18/77

3D1/18/18\G#
3D1/18/19\G
0018 +07.55V
0019 +06.18V \u

PROCEDURE	REQUIREMENT	TOLERANCE	PASS	FAIL
<p>J26. (Cont'd)</p> <ul style="list-style-type: none"> Under FUNCTION, depress DC pushbutton switch. 	<p>MAC ANALOG MEASUREMENT reads ^{+6.18} +6.000 VOLTS lamp ON</p>	<p>+0.75 V ---</p>	<p>✓</p>	<p>---</p>
<p>J27. Change MAC ADDRESS to 19</p>	<p>---</p>	<p>---</p>	<p>---</p>	<p>---</p>
<p>J28. Place MAC CONTROL SELECT switch to the right position.</p>	<p>Terminet prints: 0018 +07.50V 0019 +06.00V</p>	<p>+0.5 V +0.4 V ---</p>	<p>✓ ✓</p>	<p>---</p>
<p>J29. At Terminet keyboard, make same entry as in step 24.</p>	<p>---</p>	<p>---</p>	<p>---</p>	<p>---</p>
<p>J30. At HUA remove patchcards from Jack Panel, turn ADDS console ON, return Terminet switches to original positions before step 24, initialize H-316R computer, and turn the Audible Alarm switch ON.</p>	<p>---</p>	<p>---</p>	<p>---</p>	<p>---</p>
<p>J31. At SBL, turn ^{disconnect rear} MAC Power Panel; supply POWER switch OFF.</p>	<p>---</p>	<p>---</p>	<p>---</p>	<p>---</p>
<p>TEST ACCEPTANCE</p>				
<p>HONEYWELL</p>		<p>DATE</p>		
<p>GOVERNMENT</p>		<p>DATE</p>		

PROCEDURE	REQUIREMENT	TOLERANCE	PASS	FAIL
<p>J32. Drop the front, hinged panel of the SBL EPUT, place the LOCAL-REMOTE switch in the LOCAL position, set in address 18 and momentarily depress the EXEC pushbutton switch. Using a DVM, read the voltage at the "AT" jack of the SBL Jack Panel.</p>	<p>DVM reads +7.50 Vdc ^{+7.56}</p>	<p>±0.5 V</p>	<p>✓</p>	
<p>J33. At SBL EPUT, place the LOCAL-REMOTE switch in the REMOTE position; close and secure the front panel.</p>	<p>---</p>	<p>---</p>	<p>---</p>	<p>---</p>
<p>J34. Place the SBL MAC Power supply switch ON.</p>	<p>---</p>	<p>---</p>	<p>---</p>	<p>---</p>
<p>J35. At SBL, pull the 150 BAUD modem card.</p>	<p>---</p>	<p>---</p>	<p>---</p>	<p>---</p>
<p>J36. At the SBL Maintenance Panel, place the SITE ALARM switch ON.</p>	<p>At HUA note the following: Audible alarm actuates SBL Alarm Display - . SITE LED (blinking) . MAJOR ALARM lamp ON . ALARM lamp ON . NON ACK lamp ON MAD (Alarm Scanner column 2) - . MAJOR ALARM lamp ON . ALARM lamp ON . NON ACK lamp ON</p>	<p>---</p>	<p>✓ ✓ ✓ ✓ ✓ ✓ ✓</p>	<p>---</p>
<p>TEST ACCEPTANCE _____</p>				
<p>HONEYWELL _____ DATE</p>				
<p>GOVERNMENT _____ DATE</p>				

✓ HUA
 (see hardware
 List, Item
 6 -
 etc)

PROCEDURE	REQUIREMENT	TOLERANCE	PASS	FAIL
J37. Turn audible alarm off; momentarily depress ACK pushbutton on SBL Alarm Display	---	---	---	---
J38. At ADDS, enter NC, SN. Wait 30 seconds, then observe SYSTEM OVERVIEW.	TELEMETRY SITE HUA <u>SBL</u> R R	---	✓	---
J39. At SBL, replace the 150 BAUD modem card, pull the 75 BAUD card and place the SITE ALARM switch on the Maintenance Panel OFF.	---	---	✓	---
J40. At SBL, momentarily close the RADIO RX A waveguide shutter, then momentarily close the RADIO RX B waveguide shutter.	---	---	✓	---
J41. At ADDS, enter NC, SN. When MAC-1-07-12 appears in upper left corner of CRT display, interrupt scan and enter NC, LS, 1, 1. Observe LINK STATUS, PAGE 1.	In RADIO field: PARAMETER RX SQUELCH HUA <u>SBL</u> *	---	✓	---
J42. Restore equipment to base-line configuration.	---	---	✓	---
<u>TEST ACCEPTANCE</u>				
<u>HONEYWELL</u>		<u>DATE</u>		
<u>GOVERNMENT</u>		<u>DATE</u>		

JAI
5/18/77

AS-1

LINK STATUS

TIME 001/0218:13

.....Ti-4000.....

MAJOR ALARM

.....RADIO.....

		HUA	SBL
ALARM	SW MAJOR	.	.
	SW MINOR	.	.
	MAJOR	.	.
STATUS	TX IN SVC	A	A
	RX IN SVC	A	A
	MAINT	.	.
PARAMETER	FER	1.0E-15	1.0E-15
	CRFRM	.	.
	BER COR DIF	-3.5830	-.2.3382

	HUA	SBL
TX PROB	.	.
RX PROB	.	.
TX IN SVC	A	A
RX IN SVC	A	A
MAINT	.	.
RX SQUELCH	.	*
RSL MARGIN	37.462	36.900
EYE MARGIN	10.899	13.142
EYE AMPL	-7.0882	-9.0741
EYE HITS	0.0	0.0
DER BER	3.8E-12	2.2E-13

PAGE 1

6.1.17 The DATEC System Operations During Degraded Conditions of Both the Communications System and the DATEC System

The latter part of Appendix J of the Field Test Plan/Procedures document demonstrates the capability of DATEC to provide information to the operator responsible for nodal control that will allow him to detect and isolate communication system faults even though one or more of the DATEC functions is degraded or inoperable. Below is a table which summarizes the procedures of Appendix J relative to this subject which should serve to guide the reader with regard to: (1) the intent of the various steps, and (2) evaluation of the test output data.

<u>Operation</u>	<u>Expected Results</u>	<u>Purpose of Demonstration</u>
J19. ADDS is turned off; computer is halted; patch TermiNet to PATE "Party Line".	No automatic scan or CRT readout.	Simulates loss of computer.
J20. Pull CONV. fuse from T1WB1.	Fails T1WB1. SBL alarm Display, MAD and audible alarm all give indication of major alarm.	With DATEC in degraded condition, fault detection and isolation information is still given when Communication system is placed in degraded condition.
J21. Turn HUA MAD power switch off.	Disables MAD.	With DATEC in a further state of degradation, the alarm display and audible alarm give detection/isolation information.
J24. Command code entered via TermiNet keyboard.	Printout of T1WB1 Maintenance voltages.	Without the use of the computer, it is still possible to fault isolate--in this case, to a module within the faulty communication system unit at a remote site.
J26, J27. MAC at SBL placed in PANEL mode; T1WB1 voltages are selected.	Readout of T1WB1 voltages.	Demonstrates still another means of getting information relative to communication system operation.
J29. Same as step J24.	Same as step J24.	Verifies that fault has been repaired.

<u>Operation</u>	<u>Expected Results</u>	<u>Purpose of Demonstration</u>
J31. MAC at SBL is disabled.	Prevents MAC from automatically processing EPUT data.	Further degradation of DATEC.
J32. EPUT placed in local mode; TlWBl voltage is selected.	Readout of TlWBl voltage.	Demonstrates still another means of getting information relative to communication system operation.
J35. Pull 150 BAUD modem card at SBL.	Disables 150 BAUD telemetry line from SBL.	Simulates loss of that part of telemetry which handles parameter data.
J36. Place SITE ALARM switch ON at SBL.	Simulates site alarm. SBL Alarm Display, MAD and audible alarm all give indication of major alarm.	Demonstrates that even with half of telemetry system down, fault detection and isolation information is still available regarding anomaly at remote site.
J39. Replace 150 BAUD modem card at SBL; remove 75 BAUD card.	Disables 75 BAUD telemetry line from SBL.	Simulates loss of that part of telemetry which handles hard alarm and two-state status information.
J40. Momentarily close waveguide shutters at SBL.	Causes momentary receiver squelches; squelch displayed on Link Status display, page 1.	Demonstrates that even with half of telemetry system down, fault detection and isolation information is still available regarding anomaly at remote site.



In addition to the validation test of Appendix J, System Simulation Scenarios were conducted with tech controllers using Appendix CC procedures demonstrating use of DATEC in a degraded condition. The tech controllers were given a short course of instruction in the use of the TermiNet patched into the PATE party line prior to conduction of these scenarios. At the start of each scenario, the computer was placed in Single Instruction mode to simulate PATE failure, and then subsequently a fault or faults were caused in the communication system. The scenario performed on 6 June 1977 illustrates the use of the TermiNet with the computer inoperative to detect a fault by issuing an alarm summary command, and then to further isolate the cause to the fuse in the Power and Alarm module of the TlWBl at Site Sibyl by examining maintenance voltages.

An example of multiple problem detection and isolation is illustrated by using data from the Appendix CC scenario conducted on 27 June 1977.

OPERATION UNDER DEGRADED CONDITIONS.
 COMM. SYS: TIWBI FUSE AT SBL; DATEC: COMPUTER DOWN.

PROCEDURE	DATE	TIME
CC1. AT HUA PLACE THE COMPUTER IN THE SINGLE INSTRUCT MODE. THIS SIMULATES A COMPUTER FAILURE.		
CC2. AT SBL, REMOVE THE CONV fuse on the POWER AND ALARM PANEL OF THE TIWBI. RECORD THE TIME.	6/6/77	0930
CC3. AT COMPLETION OF THE TEST REPLACE fuse IN TIWBI EQUIPMENT.		1015
CONDUCTED BY <u>T. J. Campbell 6/6/77</u> OBSERVED BY _____		

DATEC SYSTEM EVALUATION WORKSHEET

OBSERVANCE (key points only)	PRINTOUT REF (ATTACH)	DATE	TIME
Systems clear ATT....//RR		6/6	0924
Computer failed at ADU indicates a fault with the TLWBL, either here or at SBL.. Have patched the TN into the MAC, and attempting to isolate the problem..//RR	7/6 June 77		1015 1020
TN printouts indicate a fault with the pwr supply on the TLWBL at SBL, for the +15 and +12 Vdc supply.. indications are that there is no problem at HUA....Have notified maint. at SBL to chk their TLWBL...//RR	8/6 June 77		1125
Problem isolated to faulty fuse on the TLWBL at SBL.. Maintenance replaced same, and all systems clear...//RR			1135
Computer back in service ATT...//RR			1147
TECH CONTROLLER			
OBSERVED BY			
	457		

#7

6 June 27

ID118\GX

ID1/18\G

0018 +07.79V \

ID1/19\G

0019 +06.22V \

3DI18

3DI/18/23\G

0018 +00.032V

0019 +00.032V

0020 +04.96V

0021 -06.06V

0022 +08.04V

0023 -06.71V \z

11252

11\G

2M\G

W J
6 June 27

2A1\G

0000000000 0000000000 0000000000 0000000000 0000000000\%

2A2\G

0001000000 0000000000 0000000000 0000000000 0000000000\%

1D1/04\G#

0018 +00.032V \0

3D1/18\G

0019 +00.032V \1 3D1/19\G

0020 +04.96V \ 3D1/20\G

OPERATION UNDER DEGRADED CONDITIONS

PROCEDURE	DATE	TIME
CC1. AT HUA, PLACE COMPUTER IN SINGLE INSTRUCT MODE.	6/27	0845
CC2. AT HUA, CLOSE HUA RX A WAVEGUIDE SHUTTER.		0846
CC3. AT COMPLETION OF TEST OPEN WAVEGUIDE SHUTTER AND RESTART COMPUTER.		0842
CC4. Pull Fuse on TMS1 @ HUA CY-104		0859
CC5. PLACE LOOP SWITCH ON @ HUA		0905

CONDUCTED BY D. Thomas Day
 OBSERVED BY _____

6.1.18 The Capability of DATEC to Recover from a Power Loss

Although a test procedure was written (Appendix I) to demonstrate DATEC's capability to recover from a power loss, this test was not intentionally performed during field tests at Ft. Huachuca. Recovery from power loss was demonstrated several times during in-plant checkout tests of DATEC. Although unplanned, this capability was utilized at least on one occasion while at Ft. Huachuca during storm activity. This is recorded in the software log by an entry on 19 July 1977 (see page 463). As the entry notes, the DATEC system recovered in an orderly manner and normal scanning was resumed.

DATE _____

TEST NO. _____

DEV. NO. _____

PAGE _____ OF _____

POWER FAILURE DUE TO STORM AT 1442 HRS, 19 JUL 77
 CRT WENT BLANK, COMPUTER WENT INTO POWER-FAIL
 RECOVERY ROUTINE - BACK ON THE AIR AT 1443 HRS
 WITH SCREEN BEING PRINTED AND SCAN CONTINUING
 AT POINT OF INTERRUPT. POWER-FAIL ROUTINE
 WORKS FINE.

20 JULY 77 - WEDNESDAY

START-UP PROCEDURE DID NOT SHOW THE PROMPT CHARACTER
 ON THE ADDS CRT. COMPUTER WAS LOOPING ABOUT 14554.
 THE ADDS WAS NOT RECEIVING FROM THE COMPUTER.
 THE EIA/CL CONNECTOR ON BACK-SIDE OF ADDS WAS LOOSE.
 TIGHTENED CONNECTOR ... BACK TO NORMAL ...

21 JULY 77 - THURSDAY

PH, TN \$SMST3 4.25.3 ALREADY DOCUMENTED ON HIPO
 AND PLAYSCRIPT.

```

21474 LDA 21625 → JMP 21727
21727 CRA
21730 STA 21743 CHEX
21731 LDA 21635
21732 JMP 21475

21537 LDAx 21636 → JMP 21733
21733 LDAx 21636
21734 STA 21743 CHEX = NON-ZERO
21735 JMP 21540
21617 CRA → JMP 21736
21736 LDA 21743 CHEX
21737 SNE
21740 JMP 21621 (RTMX)
21741 CRA
21742 JMPx 21456
21743 0 BSE FOR CHEX
  
```

PATCH TO INSURE
 THAT THE BEM
 SELF TEST VOLTAGE
 TOLERANCES ARE
 CHECKED

6.1.19 The Ability of Nodal Site to Obtain Information on Parameters/Alarms Monitored at the Remote Site



This aspect of DATEC's capabilities was repeatedly demonstrated throughout all phases of the field tests. This is indicated in the test data for the validation portion of field tests as will be noted in Section II of the Field Test and Evaluation Report. Also, the capability of DATEC to provide information at the nodal site regarding the remote site even though in a degraded condition was addressed in paragraph 6.1.17 of this section.

The usefulness of this capability is most apparent in data taken from the System Simulation Scenarios. Two examples, Appendix N (7 June) and Appendix BB (21 June), follow. A third example, Appendix O (2 June) may be found on pages 236 through 241. The tech controllers' own remarks indicate this most clearly. Note in the Appendix BB scenario that although pulling the fuse from the T1-4000A unit at Ft. Huachuca results in alarms at both Ft. Huachuca and Site Sibyl, the fault was correctly isolated through the use of additional information from the remote site; i.e., T1-4000 maintenance voltages.

PROCEDURE	DATE	TIME
<u>Reciprocal Path Problem</u>		
N1. Insert 10dB of attenuation between equalizer and IF in the A and B receivers at both HUA and SBL.		
<u>Transmit Antenna Only at Sibvl</u>		
N2. Insert 10dB of attenuation between equalizer and IF in the A and B receivers at HUA and the B receiver only at SBL.	6-7-77	0843
<i>(Accomplished by inserting 10dB of attenuation in transmit waveguide @ SBL)</i>		
N3. Restore equipment to baseline configuration	6-7-77	0906
CONDUCTED BY <u>C L Christy</u> 6-7-77		
OBSERVED BY _____		

7 June 77 Pg # 1

DATEC SYSTEM EVALUATION WORKSHEET

OBSERVANCE (key points only)	PRINTOUT REF (ATTACH)	DATE	TIME
Start new day with all systems clear, and system data attached...////PR	1-4/7 June 77	6/7	0840
CRT display shows Amber on both "A" & "B" radio here at HUA...Also showing RFD FLAG on the RSL margin here at HUA...////PR	5/7 June 77		0848
Displays now showing Amber for "B" radio at SBL also...LP display indicates RSL margin for both "A" & "B" radios at HUA, and for "E" radio at SBL have dropped drastically...////PR	6-7/7 June 77		0900
Have requested SBL maintenance check his antenna alignment, as indications are that this is cause of degrading RSL margins...////PR			0905
Problem isolated/solved..SBL maintenance re-aligned his antenna set-up....////PR	8/7 June 77		0911
<p>TECH CONTROLLER </p> <p>OBSERVED BY </p>			

2 7 June 77

10-005

LINK STATUS

TIME 1537452:30

.....CY-104.....

.....E191.....

ALARM	SERVICE	HUA	SRL	OFFICE	HUA	SBL
	REMOTE					
STATUS	MAINT			MAINT		
PARAMETER	CHANNEL			FBR <1.0E-6	<1.0E-6	
				REFRAME		
SITE ALARMS	ENTRY					
	FIRE					
	AC PWR					
	BATTERY					
	W.A. PR					
	W.G. HV					
	FLOOD					

PAGE 2

MAC-1-01-06

LINK PERFORMANCE ASSESSMENT - RADIOS

TIME 1537453:30

	LAST SCAN	LAST HR	MEAN	DEV	LAST 24 Hr	MEAN	DEV	LAST 30 DAYS	MEAN	DEV	LAST 30 MINS	MEAN	DEV	
HUA RSLMAR	29.103	29.519	29.525	.71764	29.694	.23740								DR
A EYEMAR	14.300	14.300	9.5761	.49295	11.235	2.5725								DR
RSLAVL	1.0000	1.0000	1.0000		1.0000									RATE
EYEAVL	1.0000	1.0000	1.0000		1.0000									RATE
EYEHIT	0.0	0.0	.02439	.05565	.74772	.74809								ZSC
HUA RSLMAR	32.013	33.156	33.821	1.5369	29.132	.53211								DR
B EYEMAR	12.459	12.459	6.3744	1.7527	4.3615	2.2521								DR
RSLAVL	1.0000	1.0000	1.0000		.93273									RATE
EYEAVL	1.0000	1.0000	1.0000		.9968									RATE
EYEHIT	0.0	0.0	.56056	1.1174	5.3953	5.6949								ZSC
SBL RSLMAR	37.700	38.200	37.200	.49161	39.860	.61219								DR
A EYEMAR	13.482	13.482	13.039	.40993	12.443	.49446								DR
RSLAVL	1.0000	1.0000	1.0000		1.0000									RATE
EYEAVL	1.0000	1.0000	1.0000		0.9935									RATE
EYEHIT	0.0	.00231	12.136	24.273	1.6931	2.3595								ZSC
SBL RSLMAR	31.400	32.958	34.331	.26134	35.278	.51504								DR
A EYEMAR	13.040	13.452	13.419	.32655	11.525	1.4311								DR
RSLAVL	1.0000	1.0000	1.0000		1.0000									RATE
EYEAVL	1.0000	1.0000	1.0000		1.0035									RATE
EYEHIT	0.0	0.0	.70829	.80053	2.5184	3.2597								ZSC
LII	1.0000	1.0000	1.0000		0.9958									

#3 7 June 77

IQ-006 LINK PERFORMANCE ASSESSMENT - RADIOS TIME 158/0332:54

	LAST SCAN	LAST HR MEAN	LAST 24 HR MEAN	LAST 24 HR DEV	LAST 30 DAYS MEAN	LAST 30 DAYS DEV	LAST 30 DAYS MEAN	LAST 30 DAYS DEV	
HUA EYEVOL	-3.6800	-3.6800	-4.0947	.45251	-3.9563	.23783	-----	-----	VLTS
A RXSQH	0.0	0.0	0.0	-----	1.0000	-----	-----	-----	RTE
HUA EYEVOL	-3.8400	-3.8400	-4.3712	.18345	-4.5289	.22754	-----	-----	VLTS
B RXSQH	0.0	0.0	0.0	-----	11.000	-----	-----	-----	RTE
HUA LNKAVL	1.0000	1.0000	1.0000	-----	0.9984	-----	-----	-----	RTE
SBL EYEVOL	-3.7500	-3.7500	-3.7892	.93590	-3.8451	.04378	-----	-----	VLTS
A RXSQH	0.0	0.0	2.0000	-----	9.0000	-----	-----	-----	RTE
SBL EYEVOL	-3.7100	-3.7350	-3.7560	.02840	-3.9271	.14494	-----	-----	VLTS
B RXSQH	0.0	0.0	2.0000	-----	4.0000	-----	-----	-----	RTE
SBL LNKAVL	1.0000	1.0000	1.0000	-----	1.0000	-----	-----	-----	RTE

M -1-07-12 LINK PERFORMANCE ASSESSMENT - TI-4000 TIME 158/0333:38

	LAST SCAN	LAST HR MEAN	LAST 24 HR MEAN	LAST 24 HR DEV	LAST 30 DAYS MEAN	LAST 30 DAYS DEV	LAST 30 DAYS MEAN	LAST 30 DAYS DEV	
HUA FER	1.0E-15	1.3E-16	2.4E-10	-----	1.7E-10	-----	-----	-----	RTE
A FERAVL	1.0000	1.0000	1.0000	-----	1.0000	-----	-----	-----	RTE
CRFRM	0.0	0.0	2.0000	-----	1.3333	.94281	-----	-----	RTE
CR/SQH	0.0	0.0	0.0	-----	0.0	-----	-----	-----	RTE
CR/HIT	0.0	0.0	0.0	-----	0.0	-----	-----	-----	RTE
HUA FER	1.0E-15	6.7E-17	1.4E-13	-----	-----	-----	-----	-----	RTE
B FERAVL	1.0000	1.0000	1.0000	-----	-----	-----	-----	-----	RTE
CRFRM	0.0	0.0	2.0000	-----	4.0000	3.2660	-----	-----	RTE
CR/SQH	0.0	0.0	0.0	-----	0.0	-----	-----	-----	RTE
CR/HIT	0.0	0.0	0.0	-----	0.0	-----	-----	-----	RTE
SBL FER	8.8E-3	1.2E-8	4.0E-6	-----	7.2E-10	-----	-----	-----	RTE
A FERAVL	1.0000	1.0000	1.0000	-----	1.0000	-----	-----	-----	RTE
CRFRM	0.0	0.0	3.0000	-----	2.3333	2.6247	-----	-----	RTE
CR/SQH	0.0	0.0	0.0	-----	4.0000	-----	-----	-----	RTE
CR/HIT	0.0	0.0	0.0	-----	5.0000	-----	-----	-----	RTE
SBL FER	5.2E-10	1.7E-11	3.0E-6	-----	-----	-----	-----	-----	RTE
B FERAVL	1.0000	1.0000	1.0000	-----	-----	-----	-----	-----	RTE
CRFRM	0.0	0.0	2.0000	-----	1.6667	1.6997	-----	-----	RTE
CR/SQH	0.0	0.0	0.0	-----	3.0000	-----	-----	-----	RTE
CR/HIT	0.0	0.0	0.0	-----	3.0000	-----	-----	-----	RTE

#4 7 June 77

AS-1

LINK PERFORMANCE ASSESSMENT - TIW31										TIME 153/0334:28	
		LAST SCAN	LAST HR MEAN	LAST 24 HR MEAN	LAST 24 HR DEV	LAST 30 DAYS MEAN	LAST 30 DAYS DEV	LAST 30 DAYS MEAN	LAST 30 DAYS DEV		
HUA	FER	1.2E-14	4.0E-16	1.6E-15	-----	3.5E-13	-----	-----	-----	RTE	
	RFRM	0.0	0.0	3.0000	-----	7.0000	5.0000	-----	-----	RTE	
SBL	FER	1.2E-14	7.2E-8	9.5E-5	-----	1.2E-9	-----	-----	-----	RTE	
	RFRM	0.0	2.0000	6.0000	-----	2.0000	2.1602	-----	-----	RTE	

IO-007

MAINTENANCE VOLTAGES - HUA										TIME 153/0335:29	
NO.	NAME	VOLTS	C	RH	AH	CG	AL	RL	MEAN	DEV	INITIAL DATE
01	TIWBI+15	15.6	G	16.5	15.7	15.0	14.2	13.5	15.5	.023	153/0337
02	TIWBI+12	12.4	G	13.2	12.6	12.0	11.4	10.8	12.4	.010	153/0337
03	TI4000+5	4.96	G	5.50	5.25	5.00	4.75	4.50	4.94	.004	153/0337
04	TI4000-6	-6.08	G	-5.40	-5.70	-6.00	-6.30	-6.60	-6.08	0	153/0337
05	RADIO+24	24.0	G	26.4	25.2	24.0	22.3	21.6	23.9	.014	153/0337
06	RADIO-20	-19.9	G	-18.0	-19.0	-20.0	-21.0	-22.0	-19.9	.003	153/0337

WAC-1-13-17

MAINTENANCE VOLTAGES - SBL										TIME 153/0336:15	
NO.	NAME	VOLTS	C	RH	AH	CG	AL	RL	MEAN	DEV	INITIAL DATE
01	TIWBI+15	15.2	G	16.5	15.7	15.0	14.2	13.5	15.1	.021	153/0311
02	TIWBI+12	12.3	G	13.2	12.6	12.0	11.4	10.8	12.3	.005	153/0311
03	TI4000+5	4.95	G	5.50	5.25	5.00	4.75	4.50	4.95	0	153/0311
04	TI4000-6	-6.04	G	-5.40	-5.70	-6.00	-6.30	-6.60	-6.04	.003	153/0311
05	RADIO+24	24.0	G	26.4	25.2	24.0	22.3	21.6	24.1	.011	153/0311
06	RADIO-20	-20.1	G	-18.0	-19.0	-20.0	-21.0	-22.0	-20.1	0	153/0311

#15 7 June 77

IQ-005			SYSTEM OVERVIEW	TIME 15-27-1648:04
	HUA	SBL		
RADIO A	.AI<	.		
B	.AS<	.		
MUX SW	.	.		
A	.	.		
B	.	.		
CY104	.	.		
	.	.		
	.	.		
	.	.		
	.	.		
	.	.		
	.	.		
TIWBI	.	.		
	.	.		
	.	.		
TELEMETRY.		
	.	.		
SITE	.	.		

MAS			LINK STATUS		TIME 15-27-1649:16
		TI-4000.....	RADIO.....
		HUA	SBL		HUA SBL
ALARM	SW MAJOR	.	.		TX PROB
	SW MINOR	.	.		RX PROB
	MAJOR	.	.		
STATUS	TX IN SVC	A	A		TX IN SVC
	RX IN SVC	A	A		RX IN SVC
	MAINT	.	.		MAINT
PARAMETER	FER	<1.0E-7	<1.0E-7		RX SQUELCH
	CRFRM	.	.		RSL MARGIN
	BER COR	NO DATA	NO DATA		EYE MARGIN
					EYE AMPL
					EYE HITS
					DER BER

#6 7 June 77

AS-2		LINK PERFORMANCE ASSESSMENT - RADIOS						TIME 1547100:44	
	LAST SCAN	LAST HR MEAN	LAST 24 HR MEAN	DEV	LAST 30 DAYS MEAN	DEV	LAST 30 DAYS MEAN	DEV	
HUA	RSLMAR	13.113	26.140	29.524	.67129	29.694	.23740	-----	DB
A	EYEMAR	13.369	13.600	13.251	1.7150	11.235	2.6725	-----	DB
	RSLAVL	1.0000	1.0000	1.0000	-----	1.0000	-----	-----	RATE
	EYEA VL	1.0000	1.0000	1.0000	-----	1.0000	-----	-----	RATE
	EYEHIT	0.0	0.0	.72133	.05226	.04772	.04809	-----	/SC
HUA	RSLMAR	23.040	30.330	33.733	1.4543	29.132	.63211	-----	DB
B	EYEMAR	11.562	11.784	7.3052	2.6253	4.3615	2.2521	-----	DB
	RSLAVL	1.0000	1.0000	1.0000	-----	.93273	-----	-----	RATE
	EYEA VL	1.0000	1.0000	1.0000	-----	0.9965	-----	-----	RATE
	EYEHIT	0.0	0.0	.46713	1.3412	5.6953	5.6949	-----	/SC
SBL	RSLMAR	37.500	37.233	37.366	.58344	39.860	.67219	-----	DB
A	EYEMAR	13.369	14.329	13.113	.40907	12.443	.47446	-----	DB
	RSLAVL	1.0000	1.0000	1.0000	-----	1.0000	-----	-----	RATE
	EYEA VL	1.0000	1.0000	1.0000	-----	0.9935	-----	-----	RATE
	EYEHIT	0.0	0.0	10.115	22.614	1.6931	2.3895	-----	/SC
SBL	RSLMAR	33.545	33.639	34.077	.75517	35.273	.60504	-----	DB
B	EYEMAR	13.597	13.597	13.450	.31228	11.595	1.6311	-----	DB
	RSLAVL	1.0000	1.0000	1.0000	-----	1.0000	-----	-----	RATE
	EYEA VL	1.0000	1.0000	1.0000	-----	0.9935	-----	-----	RATE
	EYEHIT	0.0	0.0	.00024	.00054	2.8104	3.9697	-----	/SC
VII	1.0000	1.0000	1.0000	-----	0.9936	-----	-----	-----	1.4

HIGH LEVEL MUX FAILURE - POWER SUPPLY (SBL)

PROCEDURE	DATE	TIME
BB1. At SBL, remove the LINE fuse from the Power and Alarm module of the NORMAL T1-4000. Record the time.	6-21-77	0906
BB2. At completion of the test, replace fuse in T1-4000 equipment.	6-21-77	0913

CONDUCTED BY

C. L. Christner 6-21-77

OBSERVED BY _____

DATEC SYSTEM EVALUATION WORKSHEET 21 June 77, Pg # 1

OBSERVANCE (key points only)	PRINTOUT REF (ATTACH)	DATE	TIME
Starting new day, with systems green.////RR		6/21	0900
Over shows major alarm for Tl-4000 switch, here and at SBL.....Also showing "A" mux red.//RR	1/21 June 77		0906
Alarms at HUA cleared...Still showing alarms on the "A" mux at SBL.....//RR			0908
System up on "B" mux at SBL...MV display indicates that SBL haveing problem with pwr supply on his "A " mux....Requested maint at SBL check this.//RR	2/21 June 77		0910
S ystems again green, back on the "A" systems.. Ma int at SBL replaced blown fuse...//			0914
System now showing amber on in-service mux's both here at SBL...Awaiting an update on the CRT.//RR			0916
CRT now shoing Green on all mux's....The parameter alarm apparently caused by switching back to the "A" mux at SBL...////RR			0926
<hr/>			
Problem isolated to a blown fuse in the "A" mux (Tl-4000) at SBL....//RR			
Displays deemed useful			
1. System overview (to initally identify problem...			
2. MI ta ble for MV at SBL (to identify exactly what was wrong with the mux at SBL)...//RR			
TECH CONTROLLER	<i>CMS</i>		
OBSERVED BY	<i>P</i>		

#2
21 June 77

MAC-3-01-06		LINK STATUS				TIME 172709 8:46			
	T1-4000.....			RADIO.....			
		HJA		SBL		HJA		SBL	
ALARM	SW MAJOR	IN PROB	.	.	.
	SW MINOR	.	.	*	.	IN PROB	.	.	.
	MAJOR	.	.	A
STATUS	TX IN SVC	A	.	B	.	TX IN SVC	A	.	A
	RX IN SVC	A	.	B	.	RX IN SVC	A	.	A
	MAINT	MAINT	.	.	.
PARAMETER	FER	<1.0E-7	.	<1.0E-7	.	RX SQUELCH	.	.	.
	CRFRA	RFL MARGIN	31.273	.	38.133
	BER COR	NO DATA	.	NO DATA	.	EYE MARGIN	0.6532	.	12.134
			.		.	EYE AMPL	-1.2677	.	-3.2885
			.		.	EYE HITS	3.1	.	0.3
			.		.	CLR BER	5.93-11	.	2.57-13

PAGE 1

MAC-3-18-23		MAINTENANCE VOLTAGES - 53E										TIME 172709 8:32	
NO.	NAME	VOLTS	C	RH	AH	CG	AL	RI	BEAT	DEV	INITIAL	DATE	
01	T1W81+15	15.2	G	15.5	15.7	15.0	14.2	13.5	15.1	.019	15370911	15370911	
02	T1W81+12	12.3	G	13.2	12.6	12.3	11.4	10.3	12.3	.003	15370911	15370911	
03	T14000+5	.324	R	5.50	5.25	5.45	4.75	4.50	4.95	.002	15370911	15370911	
04	T14000-6	-.001	R	-5.40	-5.70	-6.00	-6.30	-6.60	-6.04	.004	15370911	15370911	
05	RADIO+24	24.1	G	26.4	25.2	24.4	22.3	21.6	24.1	.356	15370911	15370911	
06	RADIO-20	-20.1	G	-15.0	-19.0	-20.4	-21.0	-22.0	-20.1	.012	15370911	15370911	

0246028 16.5 15.7 15.0 14.2 13.5 058 15.1 .013 1537091100102545T111418 T1

33SYSTEM OVERVIEWRADIO A BIS. .C 150 CF. .E 150X 5WEL.

6.1.20 The Effects on DATEC Caused by Degradation or Total Outage of the Transmission Link Connecting the PATE with the Remote Site DATEC Equipments

The DATEC system has a built-in test routine which checks the validity of data being transmitted from the remote site. The purpose of this test is to reject (i.e., not use) data which may be incorrect and to alert the operator of the fact that questionable data is being received at the PATE. If for some reason the transmission link degrades to the point that the command sent by the PATE to a remote site is not "echoed back" correctly, the data requested is not processed and an error message such as "MAX RETRANS" or "NO RESPONSE" is generated as well as an alarm asterisk in the Telemetry Field on the System Overview display. See paragraph 6.1.2 of this section for further discussion of this feature.

During special tests which were performed to obtain bit error rate (BER) correlation data with DATEC connected first to the Collins AN/FRC-162 radio and then to the AVANTEK DR8A radio, it was noted that the telemetry link remained intact even though the received signal level had dropped to such a value as to cause error rates greater than 10^{-2} . At this point, reframes on the T1-4000 and T1WB1 were noted, but the built-in-test routine described in the preceding paragraph detected no telemetry transmission errors. Table 6-8 is a summary of results obtained when tests were conducted first on the 150 Baud telemetry link and then on the 75 Baud link.

An example of the effects of DATEC caused by degradation or total outage of the transmission link was obtained during performance of the System Test Scenario of Appendix T on 8 June 1977. In this test, damage to Site Sibyl equipment by an assumed lightning strike was simulated. Increasing degradation was simulated by adding attenuation in the transmit waveguide at Sibyl at the rate of 2 dB per minute. Note from the computer printout at 1509 hours that valid Maintenance Voltage data is being received from Site Sibyl one minute before the link went completely off the air as noted by squelches on both A and B receivers at Ft. Huachuca. Note also from the next printout made following the link (and therefore telemetry) outage which shows the error message "NO RESPONSE" as a result of the query for MAC voltages 1 through 6 at Sibyl (MAC-3-01-06). Finally, observe that the telemetry is in alarm ("R") condition in the printout made at 1519 and the Radio RX alarm (RI< opposite RADIO A and RS< opposite RADIO B) under HUA has been activated.

TABLE 6-8. TELEMETRY PERFORMANCE EVALUATION

Conditions: Reduce RSL, SBL to HUA (RX A)
 Normal RSL, HUA to SBL
 Receiver locked to RX A at HUA:
 Squelch set to minimum

150 B/S Telemetry Evaluation:

<u>Status</u> <u>(Telemetry from SBL)</u>	<u>RSL Margin (HUA)</u>	<u>System BER</u>
OK	-5.28 dB	8.6×10^{-4}
OK	-6.8 dB	3.2×10^{-3}
OK	-8.dB	2.6×10^{-2}
OK	<-9.0 dB	Loss of Sync

75 B/S Telemetry Evaluation:

<u>*SBL Alarm Scanner Operation</u>	<u>RSL Margin (HUA)</u>
OK (No false alarms)	6.7 dB
OK (No false alarms)	0.17 dB
OK (No false alarms)	-6.2 dB
OK (No false alarms)	-9.0 dB

*TlWB1 alarm was activated to confirm proper operation

PROCEDURE	DATE	TIME																
<p>At SBL, with power off, before scenario begins, perform the following steps (refer to figure T-1 for special test equipment installation information):</p> <ul style="list-style-type: none"> • Install the Frame Bit Error Generator (FBEG) in transmit baseband between the T1-4000 and radio. • Install attenuators (x 10) between equalizer and IF in both A and B receivers. Set attenuators to 0dB. • Change wiring of SITE ALARM switch at MAINTENANCE panel in SBL ARS rack from the DATEC Flood alarm monitor line to the Battery alarm monitor. <i>Insert wire from AS 132-19 to TP2-127, (2) and jumper between TR2-106 & T52-129.</i> 																		
<p>T1. At some time after scenario starts, interrupt or in some way turn off power to all equipment, communication and DATEC, at SBL; record time. Leave off for 10 seconds. While power is off, place SITE ALARM switch on MAINTENANCE panel in SBL ARS rack ON.</p>	6-8-77	14 36																
<p>T2. After 10 seconds have elapsed, turn all power at SBL back on; restore all communications equipment to normal operation, then insert 10 dB of attenuation in the receiver that is in service. Perform this step as quickly as possible.</p>	6-8-77	1436																
<p>T3. For the next 15 to 20 minutes periodically depress the pushbutton switch on the FBEG with the selector switch set to NARROW. (The rate should be one occurrence every two to three minutes). Record the time each perturbation is introduced.</p>																		
<table border="0"> <tr> <td style="padding-right: 20px;">Perturbation No.</td> <td>1</td> </tr> <tr> <td style="padding-right: 20px;">"</td> <td>2</td> </tr> <tr> <td style="padding-right: 20px;">"</td> <td>3</td> </tr> <tr> <td style="padding-right: 20px;">"</td> <td>4</td> </tr> <tr> <td style="padding-right: 20px;">"</td> <td>5</td> </tr> <tr> <td style="padding-right: 20px;">"</td> <td>6</td> </tr> <tr> <td style="padding-right: 20px;">"</td> <td>7</td> </tr> <tr> <td style="padding-right: 20px;">"</td> <td>8</td> </tr> </table>	Perturbation No.	1	"	2	"	3	"	4	"	5	"	6	"	7	"	8		
Perturbation No.	1																	
"	2																	
"	3																	
"	4																	
"	5																	
"	6																	
"	7																	
"	8																	
<p>T4. In a period of approximately 4 seconds, introduce in both receivers at SBL enough attenuation to drive both receivers below the switchover point;</p>		1458																
<p>CONDUCTED BY <u>C. L. Christy</u> 6-8-77</p>																		
<p>OBSERVED BY _____</p>																		

PROCEDURE	DATE	TIME
<p>then remove the attenuation just introduced. (The receiver not in service at the completion of this step should have 10dB of attenuation still inserted.</p> <p>T5. At SBL, introduce maximum attenuation using the attenuator installed in the transmitter waveguide.</p> <p>T6. At completion of this scenario, restore all equipment to baseline configuration.</p>	<p>START</p> <p>LINK DOWN</p>	<p>1459</p> <p>1510</p>
<p>CONDUCTED BY <u>C. J. Christy</u></p> <p>OBSERVED BY _____</p>	<p>6-8-77</p>	

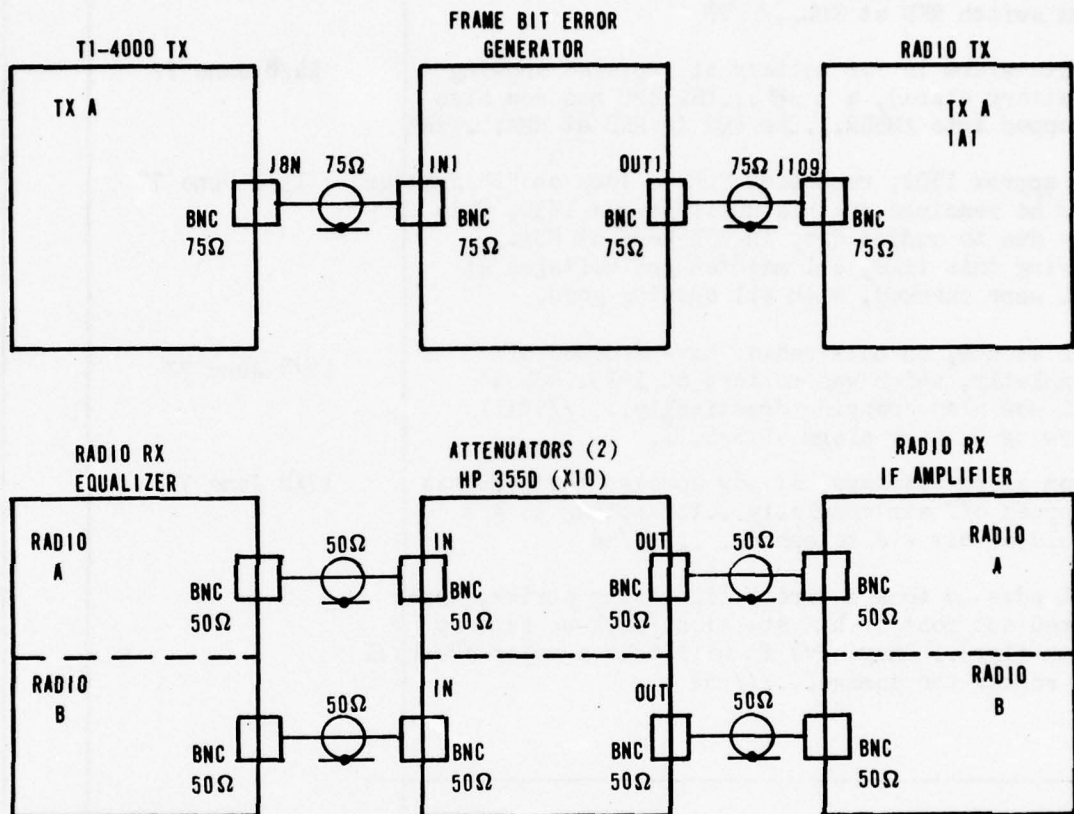

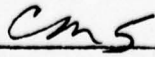

Figure T-1. Test Configuration,
Multiple Link Equipment Failures

OBSERVANCE (key points only)	PRINTOUT REF (ATTACH)	DATE	TIME
<p>All systems green att...///RR CRT display (overview) shows a RED FLAG at SBL for site alarm, also showing "A" radio Amber and Aux switch RED at SBL...///RR</p>	<p>14/8 June 77</p>	<p>6/8</p>	<p>1407 1442</p>
<p>Site alarm is for battery at SBL (also showing battery alarm), at SBL...RSL SBL has now also dropped into AMBER...The FER is RED at HUA...//RR</p>	<p>14/8 June 77</p>		<p>1445</p>
<p>At approx 1502, requested SBL to lock on "B" transmitter, and he remained on this until approx 1530. This was due to sudden drop in RSL here at HUA... During this time, all maintenance voltages at SBL were checked, with all showing good.</p>	<p>15/8 June 77</p>		<p>1530 1504</p>
<p>RSL at HUA, on both radios have dropped off completely, which was noticed at 1515..RSL at SBL now also dropping drastically....//Still showing battery alarm at SBL....</p>	<p>16/8 June 77</p>		<p>1515</p>
<p>From alarm displays, it now appears that SBL has dropped off air completely...Attempting to get ahold of him via telephone.....//RR</p>	<p>17/8 June 77</p>		<p>1519</p>
<p>SBL advs he took a direct lightning strike, which wiped out most of his station (back-up battery bank also).. They advs it will take a major overhaul to repair the damage...//RRR</p>			<p>1525</p>
<p>TECH CONTROLLER OBSERVED BY</p>	<p> </p>		

MAC-1-07-12

MAINTENANCE VOLTAGES - SBL

TIME 159/1454:10

NO.	NAME	VOLTS	C	RH	AH	CG	AL	RL	MEAN	DEV	DATE
N	NAME	VOLTS	C	RH	AH	CG	AL	RL	MEAN	DEV	DATE
01	T1WB1+15	15.2	G	16.5	15.7	15.0	14.2	13.5	15.1	.009	153/0911
02	T1WB1+12	12.3	G	13.2	12.6	12.0	11.4	10.8	12.3	.002	153/0911
03	T14000+5	4.95	G	5.50	5.25	5.00	4.75	4.50	4.95	.002	153/0911
04	T14000-6	-6.04	G	-5.40	-5.70	-6.00	-6.30	-6.60	-6.04	.002	153/0911
05	RADIO+24	24.1	G	26.4	25.2	24.0	22.8	21.6	24.1	.009	153/0911
06	RADIO-20	-20.1	G	-18.0	-19.0	-20.0	-21.0	-22.0	-20.1	1.2E	153/0911

15/18 June 77

AS-2

LINK STATUS

TIME 159/1458:44

	T1-4000.....	RADIO.....	
		HUA	SBL	HUA	SBL
ALARM	SW MAJOR
	SW MINOR	*	.	.	.
	MAJOR
STATUS	TX IN SVC	B	A	A	A
	RX IN SVC	A	A	A	A
	MAINT
PARAMETER	FER	<1.0E-7	<1.0E-7	.	.
	CRFRM
	BER COR	NO DATA	NO DATA	28.873	28.583 A
				12.450	15.200
				4.7787	0.0
				5.5E-13	1.0E-15
					PAGE 1

16 / 8 June 77

MA-2 MAINTENANCE VOLTAGES - SBL TIME 159/1509:06

NO.	NAME	VOLTS	C	RH	AH	CG	AL	MAJOR ALARM		INITIAL	
								RL	MEAN	DEV	DATE
01	TIWB1+15	15.2	G	16.5	15.7	15.0	14.2	13.5	15.1	.009	153/0911
02	TIWB1+12	12.3	G	13.2	12.6	12.0	11.4	10.8	12.3	0	153/0911
03	TI4000+5	4.95	G	5.50	5.25	5.00	4.75	4.50	4.95	0	153/0911
04	TI4000-6	-6.04	G	-5.40	-5.70	-6.00	-6.30	-6.60	-6.04	.002	153/0911
05	RADIO+24	24.0	G	26.4	25.2	24.0	22.3	21.6	24.1	.009	153/0911
06	RADIO-20	-20.1	G	-18.0	-19.0	-20.0	-21.0	-22.0	-20.1	1.2E	153/0911

MAC-3-01-06 LINK PERFORMANCE ASSESSMENT - RADIOS TIME 159/1515:34
NO RESPONSE.

	LAST SCAN	LAST HR MEAN	LAST 24 HR MEAN	LAST 24 HR DEV	LAST 30 DAYS MEAN	LAST 30 DAYS DEV	ALARM	MST 30 MTHS	MEAN	DEV	
HUA	RSLMAR-2.0575	-2.0575	7.7003	12.642	25.066	9.1740					DB
A	EYEMAR-28.609	5.5808	-3.5421	4.5658	9.1217	4.2871					DB
	RSLAVL 0.0	0.0	.39113		.84815						RATE
	EYEAVL 0.0	.83333	.35338		.85143						RATE
	EYEHIT 364.09	61.478	192.80	94.110	33.108	66.134					/SC
HUA	RSLMAR-4.2703	-4.2703	32.300	2.1344	30.682	2.0236					DB
R	EYEMAR 13.028	8.5843	9.8703	2.4385	6.5218	2.7858					DB
	RSLAVL 0.0	0.0	1.0000		.93701						RATE
	EYEAVL 1.0000	1.0000	1.0000		0.9978						RATE
	EYEHIT 169.30	42.325	0.0	0.0	4.1507	4.9477					/SC
SBL	RSLMAR 26.182	35.040	38.767	1.0381	39.132	1.1163					DB
A	EYEMAR 15.290	14.745	13.601	.31575	12.769	.56043					DB
	RSLAVL 1.0000	1.0000	1.0000		1.0000						RATE
	EYEAVL 1.0000	1.0000	1.0000		0.9956						RATE
	EYEHIT 0.0	0.0	.01857	.07305	3.0423	4.0440					/SC
SBL	RSLMAR 8.3571	31.085	33.856	.77255	34.701	.86241					DB
B	EYEMAR 15.290	14.551	13.649	.44282	12.334	1.5540					DB
	RSLAVL 1.0000	1.0000	1.0000		1.0000						RATE
	EYEAVL 1.0000	1.0000	1.0000		0.9957						RATE
	EYEHIT 0.0	.02880	0.0	0.0	1.6563	3.3690					/SC

MA-2

SYSTEM OVERVIEW

TIME 159/1519:31

	HUA	SBL
RA 0 A	.RI<	>IA.
B	.RS<	>SA.
MUX SW	.R<>	.
A	.R<>	.
B	.R<>	.
CY104	.	.
	.	.
	.	.
	.	.
	.	.
	.	.
	.	.
TIWBI	.R01<>	.
	.	.
	.	.
TELEMETRY.	R	R
SITE :	:	R

MAJOR ALARM

17/8 June 77

IQ-005

LINK STATUS

TIME 159/1521:26

	TI-4000.....		RADIO.....	
		HUA	SBL		HUA	SBL
ALARM	SW MAJOR	*	.	TX PROB	.	.
	SW MINOR	*	.	RX PROB	AB	.
	MAJOR	AB	.		.	.
STATUS	TX IN SVC	B	.	A	.	R
	RX IN SVC	A	.	A	.	A
	MAINT
PARAMETER	FER	<1.0E-7	.	<1.0E-7	.	.
	CRFRM	*
	BER COR	NO DATA	.	NO DATA	.	.

RSL MARGIN	-2.0575	R.	26.182	A
EYE MARGIN	-28.699	R.	15.290	
EYE AMPL	-8.0323	A.	-3.9677	
EYE HITS	364.09	R.	1.3	
DER BER	.00100	R.	1.0E-15	

PAGE 1

6.1.21 The Man-Machine Interface and if the Interface Can Be Easily Accomplished in the Operational Environment, and If It Is Presented In a Format that Is Useful to Operational Personnel

The ease with which the System Simulation Scenarios test phase was started and the manner in which the scenarios were conducted throughout this phase of field tests present solid evidence of a compatible man-machine interface. The three tech controllers who originally started the scenarios received about one day of training from Honeywell personnel and then were allowed about one day of "hands-on" familiarization by themselves using a notebook of Honeywell prepared procedures. From that point on they were essentially on their own and received minimal help from Honeywell personnel - none while a particular scenario was in progress. After the scenario test phase had started, two additional tech controllers joined the group. These two received only an hour or two of indoctrination from Honeywell; the rest of their training was on-the-job, working with the more experienced tech controllers.

As the tech controllers gained experience they began to use more than just the conventional displays (i.e., System Overview, Link Status, Link Performance Assessment and Maintenance Voltages) in the normal scan mode to isolate and verify problem areas. They were becoming proficient in the use of the Monitor Immediate scan mode; in use of the CY-104 VF IQCS scan/display and in calling up parameter statistics tables to check past performance. The 29 June 1977 scenario data from Appendix EE illustrates the use of a number of different displays in a multiple failure scenario in which eight separate problems were found (refer to pages 417 through 427). The ease and speed with which various displays were interpreted is apparent. All the faults were traced in approximately 80 minutes.

Appendix R scenario, performed on 13 June 1977, involved introduction of an interfering frequency at the in-service receiver waveguide at Ft. Huachuca - a difficult problem to trace. Printouts from this scenario shown on pages 283 through 290 illustrate use of the Monitor Immediate mode and parameter tables to pinpoint the cause by studying its effects.

Although the tech controllers learned quickly to use the various tools that are available and put them to efficient use in solving problems as the above two scenarios illustrate, they still had suggestions for improvements to format:

1. FER data for the standby T1-400 should be available as well as the in-service unit on the Link Status display. The reason for this was to be able to assess the status of the standby unit before switching it on-line. This information was not added to the Link Status display as that would have meant a significant software change.

It was added, however, to the Monitor Immediate mode. Update time is still dependent on the sample time base of the EPUT. A special, shorter, time base for use in the Monitor Immediate mode was discussed in paragraph 6.1.5.

2. Another improvement that was suggested involved identifying on the Link Status and Link Performance Assessment displays the radio being monitored relative to Eye data. Only the A or B radio at a given site is monitored each scan. Each radio is therefore monitored once every other scan; or in this case once every seven to eight minutes. The Monitor Immediate mode takes care of this deficiency to some extent. If eye parameters are being examined to the extent that this rate of update becomes a significant factor, then the nodal controller is most likely in a maintenance or troubleshooting mode. The tech controller then has the option of going to the Monitor Immediate mode wherein the update rate of Eye parameters is limited only by the BEM. This amounts to a few seconds for Eye Margin, Eye Amplitude, Derived BER and Eye Voltage (dispersion voltage) and 90 seconds for Eye Hits. The feasibility of shortening the sample time for Eye Hits while in the Monitor Immediate mode was also discussed in paragraph 6.1.5.
3. Probably the most significant changes suggested were in the System Overview and Link Status displays. This was previously mentioned in paragraph 6.1.9.6. The display formats that the tech controllers recommended are shown there.

6.1.22 The Ability to Use DATEC Without the Support of On-Site Computer Software Personnel

The two Air Force tech controllers and Army personnel who were to evaluate the DATEC system were given a one day lecture and another day of hands-on experience to become familiar with the equipment and operator interaction commands. They were given a handout showing how to use all operator commands. Honeywell software personnel were available during this training period to answer questions and demonstrate the use of commands when requested. All personnel involved picked up the ability to operate the system within two to three hours of training. This included system start up, accessing and changing the data base, and bringing up the system displays.

During the running of the system scenarios, software personnel were not in the presence of the tech controllers. The system was run entirely by the tech controllers. After the first two weeks, they conducted operations from another building containing only the ADDS and TermiNet equipments. The software personnel assisted in running the scenarios from the equipment building and were available in case of system failure. Software and hardware personnel could monitor the tech controllers progress through a second ADDS terminal located in the equipment

building. There were only two instances during the month of evaluation in which Honeywell offered assistance to the tech controllers:

1. Appendix BB, 2 June 1977 - High Level MUX Failure, Power Supply - SBL. It was observed during the running of this test that the tech controllers were bringing up displays before the data displayed could be updated as a result of the perturbation. This is illustrated on Page 2 of this test, dated 2 June 1977. The controllers assumed that the maintenance voltages were good because they had not been updated yet. It takes approximately four minutes to update these voltages after starting the scan. At the completion of this test the controllers were given a detailed description of the relationship between the scanning process and the parameter value updates. This cleared up the misunderstanding.
2. Use of Overview Display. This instance is closely related to (1) above. It was observed early in the scenario processing that the controllers were rapidly jumping from one display to another in an attempt to find the problem. By doing this, they were interrupting the scan and therefore no parameters were being updated. The reason that this was being done was that, having been forewarned that a problem existed, they instantly went into a maintenance or fault isolation mode. This is not the intent of the nodal control concept. A meeting was held on 16 June 1977 in which it was suggested that for each scenario the overview display be brought up and used for detection of link problems. Once this display points out a problem, then the other displays can be used to isolate the problem to the equipment level at a site. Following this meeting, as the test results show, the controllers became more organized in their DATEC system usage.

HIGH LEVEL MUX FAILURE - POWER SUPPLY (SBL)

PROCEDURE	DATE	TIME
BB1. At SBL, remove the LINE fuse from the Power and Alarm module of the NORMAL T1-4000. Record the time.	6-2-77	1053
BB2. At completion of the test, replace fuse in T1-4000 equipment.	6-2-77	1125
CONDUCTED BY <u>C. L. Christy</u> 6-2-77 OBSERVED BY _____		

DATEC SYSTEM EVALUATION WORKSHEET 2 June 77 Pg #2

OBSERVANCE (key points only)	PRINTOUT REF (ATTACH)	DATE	TIME
A waiting tst # 2...////RR			1032
CRT shows alarms at 65.. appears he has switched to " " side of T14000.also showing SE Minor alarm at SEL..	9/2 June 77		1054
Have cheked all other displays including voltage and all appears fivers.. Still showing SEL on the "B" side of T14000... Unsure A TT why he has switched Requesting maintenance there to chker out.////RR			1118
Honeywell advsd that we shud be able to isolate further, so did a re-run of displays, and on this one, the +5 and -6 Vdc pwr spply at SEL appear bad. Advsd maint of this... NOTP... These did not appear bad on the first two (2) runs of the maintenance voltages...////RR	10/2 June 77		1125
Problem resolved.. SEL corrected trbls with pwr supplies.. Still don't know why CRT did not display problem originally...////RR			1126

TECH CONTROLLER



OBSERVED BY

TIWB1

TELEMETRY.

SITE

#10

2 June 77

AS-1

LINK STATUS
.....T1-4000.....
HUA SBL

TIME 153/1108:10
.....RADIO.....
HUA SBL

ALARM	SW MAJOR	.	.	TX PROB	.	.
	SW MINOR	.	*	RX PROB	.	.
	MAJOR	.	A		.	.
STATUS	TX IN SVC	A	.	B	TX IN SVC	A . A
	RX IN SVC	A	.	B	RX IN SVC	A . A
	MAINT	.	.	MAINT	.	.
PARAMETER	FER	<1.0E-7	.	<1.0E-7	RX SQUELCH	.
	CRFRM	.	.	.	RSL MARGIN	29.487 . 41.333
	BER COR	NO DATA	.	NO DATA	EYE MARGIN	10.789 . 12.459
					EYE AMPL	-8.8065 . -8.9677
					EYE HITS	0.0 . 0.0
					DER BER	4.4E-12 . 5.5E-13

MAC -18-23

MAINTENANCE VOLTAGES - SBL

TIME 153/1119:18

NO.	NAME	VOLTS	C	RH	AH	CG	AL	RL	MEAN	DEV	INITIAL	DATE
01	TIWB1+15	15.2	G	16.5	15.7	15.0	14.2	13.5	15.2	0	153/0911	
02	TIWB1+12	12.3	G	13.2	12.6	12.0	11.4	10.8	12.3	0	153/0911	
03	T14000+5	.375	R	5.50	5.25	5.00	4.75	4.50	4.95	0	153/0911	
04	T14000-6	.007	R	-5.40	-5.70	-6.00	-6.30	-6.60	-6.04	0	153/0911	
05	RADIO+24	24.1	G	26.4	25.2	24.0	22.8	21.6	24.1	0	153/0911	
06	RADIO-20	-20.1	G	-18.0	-19.0	-20.0	-21.0	-22.0	-20.1	0	153/0911	

6.1.23 The Ease with which Data Base Changes Most Frequently Required During Operation Can Be Accomplished

In the DATEC system, the operator has been given the ability to observe the contents of the data base with the access command. In order to change it or to enter new data, he must use the change command. The data base items that can be changed are listed below in the order of frequency of change.

- a. Alarm thresholds
- b. Site alarm trend table
- c. System statistics
- d. Site thresholds

The alarm thresholds are a set of nine numbers as shown in Figure 6-10. They are used by the alarm module to determine a specified parameter's alarm color. This is done by determining where the parameter's value falls with respect to the threshold values. The hysteresis areas were incorporated to prevent alarm flicker or the oscillation of alarm color due to slight variations in parameter value. If a parameter's value falls in a hysteresis area, its alarm color is set to the color from which it came.

The DATEC system is presently capable of storing 140 sets of alarm thresholds. To change the thresholds, the operator merely types in the following command:

```
!NC,CH,AT,n
```

Where n represents the set of thresholds desired. The computer responds with:

```
ENTER ITEM NUMBER
```

The operator is now expected to enter a number from 1 to 9 representing one of the threshold values that he wishes to change. Upon entering this number, the computer responds with:

```
ENTER FLOATING POINT VALUE
```

The operator must then respond with the threshold value. The computer continues requesting the item number and value until the operator terminates the process by entering a "NEW LINE" character in response to the item number request.

This command was used more frequently than any other data base command. It was used to set up the validation test thresholds, the system scenario thresholds and the DR8A radio thresholds. As seen from its structure, it is very easy to learn and use. A complete set of thresholds can be entered in approximately two minutes.

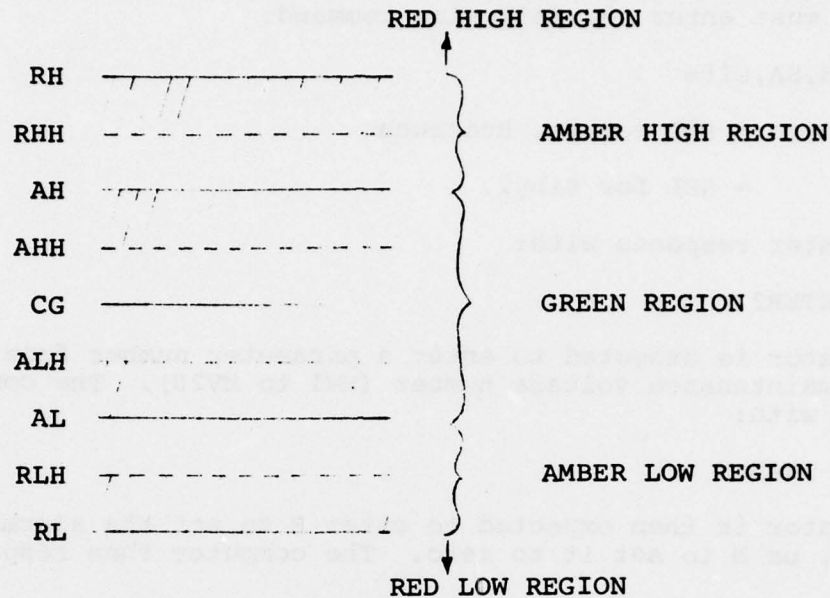

FIGURE 6-10. ALARM THRESHOLDS

Parameters can be enabled or disabled for alarming and trending in the DATEC system. This is done by changing the Site Alarm Trend table which contains three pieces of information for each parameter.

1. Alarm enable bit. This bit is set to 1 to enable a parameter for alarming and to 0 to disable alarming.
2. Alarm threshold indicator. This is a number from 1 to 140 indicating the alarm threshold set to be used for alarming.
3. Trend enable level. This is a two bit field indicating the type of trending to be performed on a parameter. It can have the following values.
 - 0 = No trending
 - 1 = Compute last hour, last 24 hours, last 30 days, last 30 months sums only.
 - 2 = Compute mean and standard deviation for the same time periods as in 1.
 - 3 = Compute sums for last hour and last 24 hours. Compute mean and standard deviation for last 30 days and last 30 months.

In order to enable a parameter for alarming and trending, the operator must enter the following command:

```
!NC,CH,SA,site
```

Where: site = HUA for Ft. Huachuca
= SBL for Sibyl.

The computer responds with:

```
PARAMETER?
```

The operator is expected to enter a parameter number from 1 to 39 or a maintenance voltage number (MV1 to MV20). The computer responds with:

```
ALARM ENABLE E/N
```

The operator is then expected to enter E to set the alarm enable bit to 1, or N to set it to zero. The computer then responds with:

```
ALARM THRESHOLD INDICATOR?
```

The operator must enter a number from 1-140 indicating the set of thresholds desired. The computer then responds with:

```
TREND ENABLE LEVEL?
```

The operator is then expected to enter a number from 0 to 3. Following this entry, the parameter question again appears. This process is repeated until all desired parameters are set up.

The structure of this command is seen to be quite simple. It leads the operator through the entry process requiring little or no knowledge of how the command works. This command was used in setting up the data base for the validation tests, system scenarios and DR8A radio tests. Examples of its use are contained in the software log books 1159 and 466 included as Addendum to the Field Test and Evaluation Report. Both the HUA and SBL site alarm trend tables can be set up in approximately 30 minutes. Single parameter changes can be made in less than a minute.

The trend algorithm keeps statistics for the last hour, last 24 hours, last 30 days and last 30 months. Up to 34 current values, 24 hourly values, 30 daily values and 30 monthly values are maintained as historical data. The operator can look at this history by entering the following command:

```
!NC,AC,SS,site
```

Where: site = HUA for Ft. Huachuca
= SBL for Sibyl.

The computer responds with:

PARAMETER?

The operator responds with the parameter number (1-39) or a maintenance voltage number (MV1-MV20). The computer responds with:

TIME PERIOD?

The operator is expected to enter:

- H - For hourly values
- D - For last 24 hours values
- M - For last 30 days values
- T - For last 30 months values

The computer then prints out the historical data requested.

This command was used extensively by the tech controllers during the system scenario tests. They used it to track the history of a parameter to determine if it was degrading during the course of the relatively short scenarios.

The site thresholds table contains the thresholds used in computing RSL Availability, Eye Availability, Hit Counts and FER Availabilities. The operator can change this table by entering:

!NC,CH,ST,site

Where: site = HUA for Ft. Huachuca
= SBL for Sibyl.

The computer responds with:

ENTER ITEM NUMBER

The operator is expected to enter a number from 1-8 representing the A or B threshold for the parameter mentioned above. The computer responds with:

ENTER FLOATING POINT VALUE

The operator is expected to enter the new threshold value.

This command was never used during validation or system scenario testing. It was used only to change thresholds when the DR8A radio testing was done.

6.2 SPECIAL SOFTWARE CONSIDERATIONS

The S.O.W. for the ATEC Digital Adaptation Study delineated several tasks/considerations in Paragraph 6.2.1 associated specifically with software. Inputs for this section were derived in large part from entries in software log books, observations made during field tests, and discussions with the technical controllers who took part in the System Simulation Scenarios. These specific items are addressed in the following subparagraphs.

6.2.1 Visibility of the Software Program Codes Logic/Structure, and Whether the Structure Will Allow Quick Isolation of Software Problems

Software Structure

The Digital ATEC software was designed using a top-down approach in which the statement of work was used to define some initial functions. Each of these functions was in turn further refined which resulted in the definition of additional functions of a simpler nature. The refining process continued until a set of basic functions were defined. The modules shown in Figures 6-11 through 6-15 were developed to implement those functions. These hierarchy diagrams give an accurate description of the software structure. One can determine what functions are performed by a module by observing the row of blocks immediately below the single defining block. For instance, the nodal control scan module (module 1.0) does the following:

1. Select monitor point (module 1.1).
2. Input major alarm summary data (module 1.2).
3. Input alarm summary data (module 1.3).
4. Input MAC voltage data (module 1.4).
5. Compute, alarm, trend parameters (module 1.5).
6. Output display (module 1.6).
7. Initialize baseband eye monitor (module 1.7).

Although the hierarchy diagrams give a good indication of the software organization, they tell nothing about data flow. This is accomplished by means of a HIPO diagram. One of these exists for each module described in the hierarchy diagrams. The HIPO diagram describes what the module does and shows the inputs used and outputs generated. As an example, the HIPO for module 1.3 is shown in Figure 6-16.

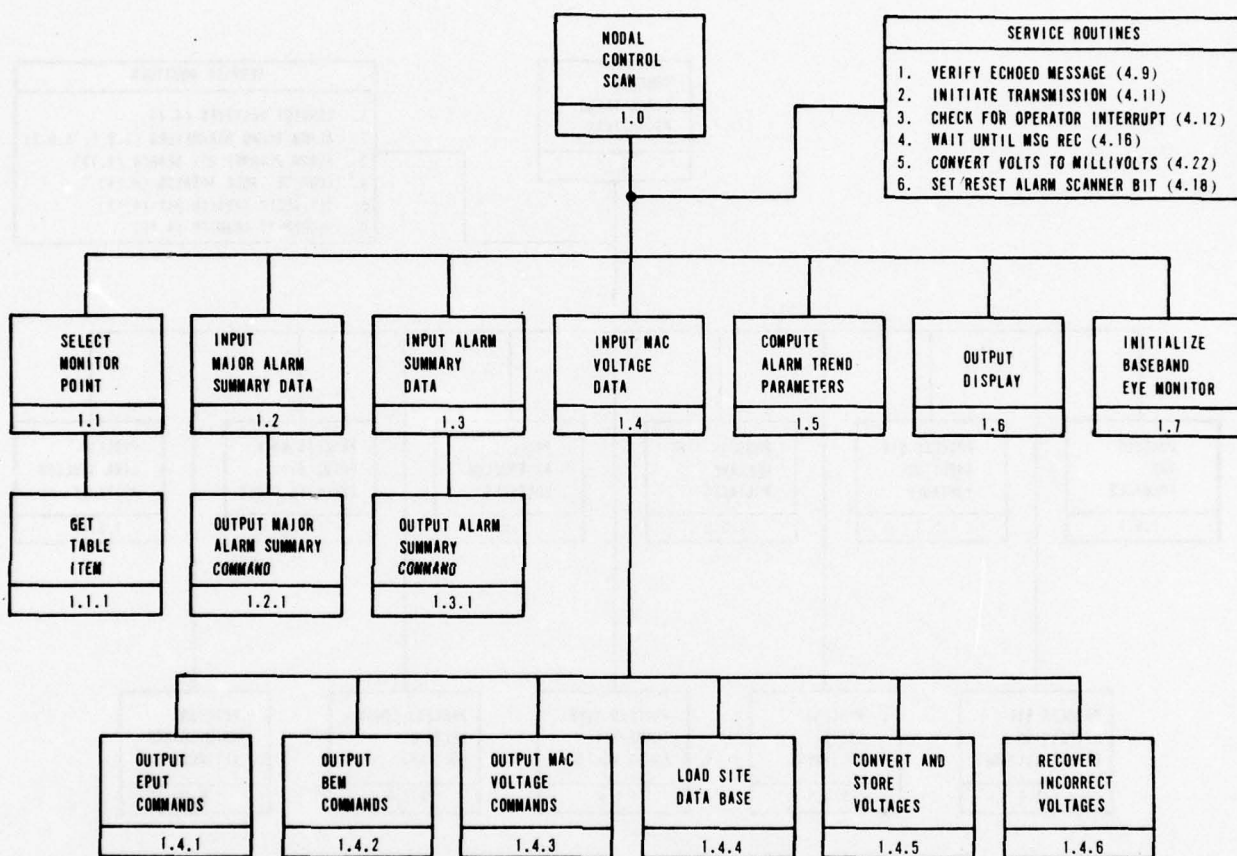

FIGURE 6-11. NODAL CONTROL SCAN HIERARCHY

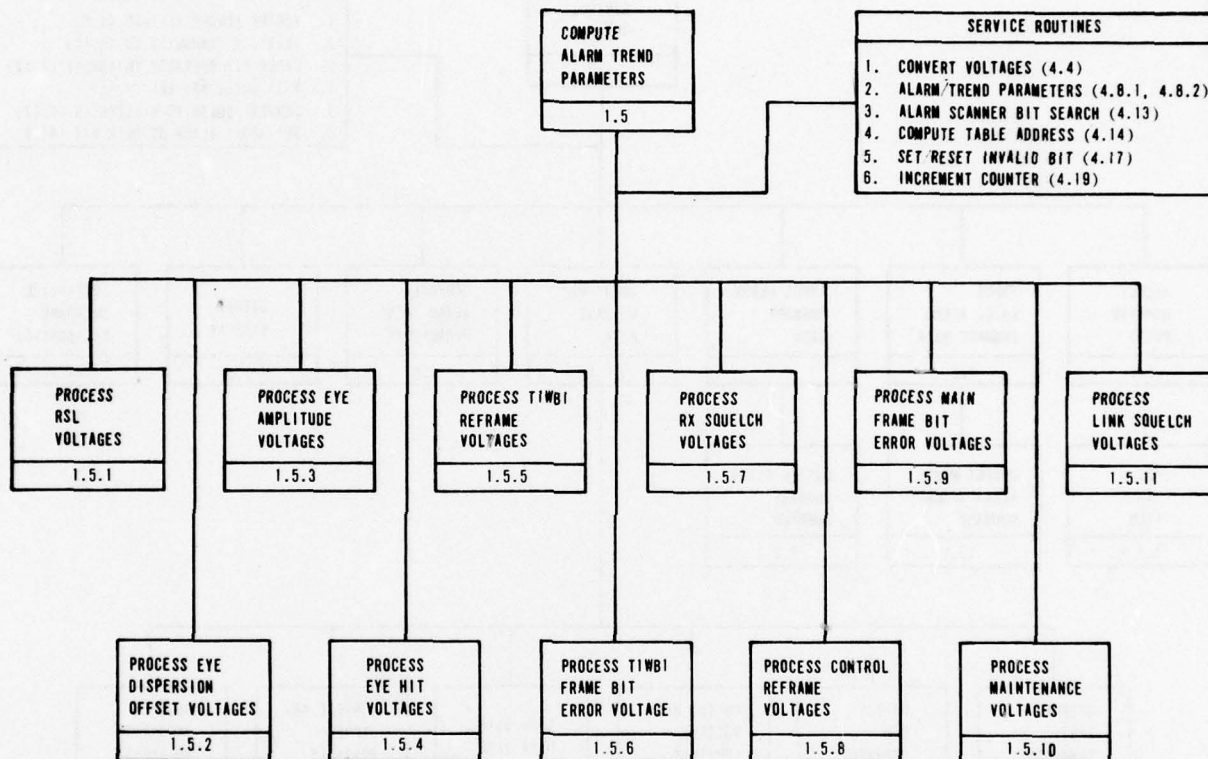

FIGURE 6-12. COMPUTE/ALARM/TREND PARAMETER HIERARCHY

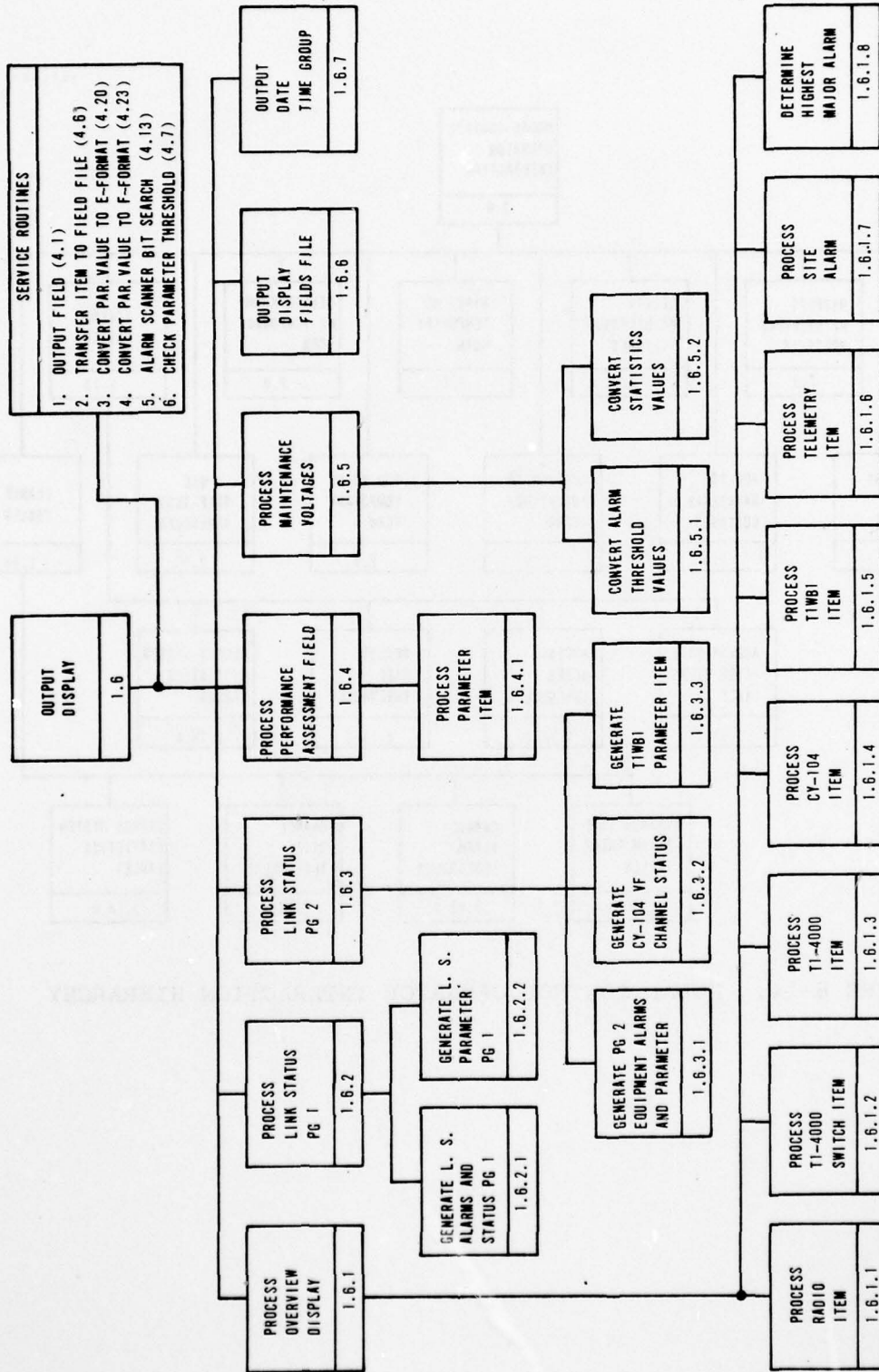

FIGURE 6-13. OUTPUT DISPLAY HIERARCHY

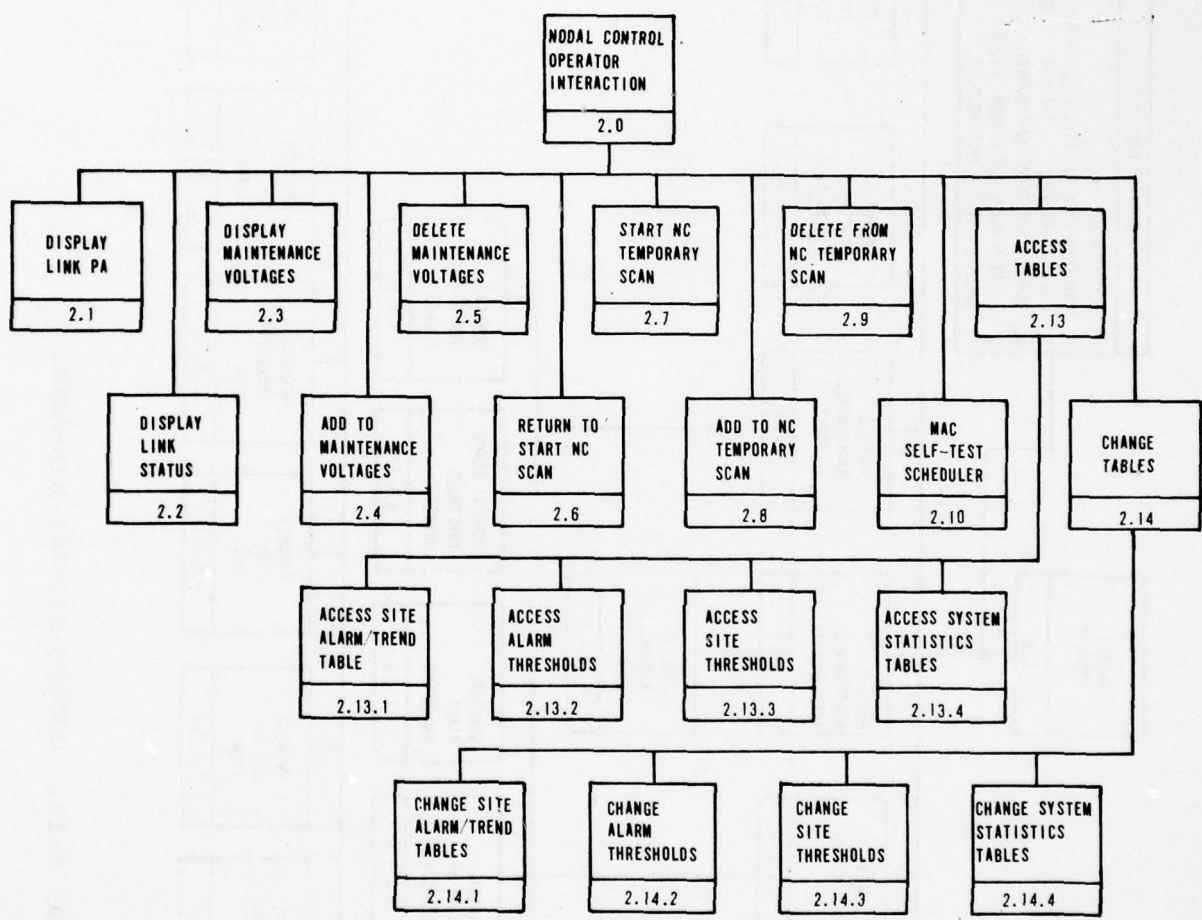

FIGURE 6-14. NODAL CONTROL OPERATOR INTERACTION HIERARCHY

AD-A051 926

HONEYWELL INC ST PETERSBURG FL AVIONICS DIV F/G 17/2
ATEC DIGITAL ADAPTATION STUDY, DEVELOPMENT AND FIELD EVALUATION--ETC(U)
JAN 78 T J CAMPBELL, W F ACKER, C L CHRISTNER F30602-75-C-0282
1077-14813-VOL-2 RADC-TR-77-431-VOL-2 NL

UNCLASSIFIED

4 of 4
AD
A051926



END
DATE
FILMED
5 - 78
DDC

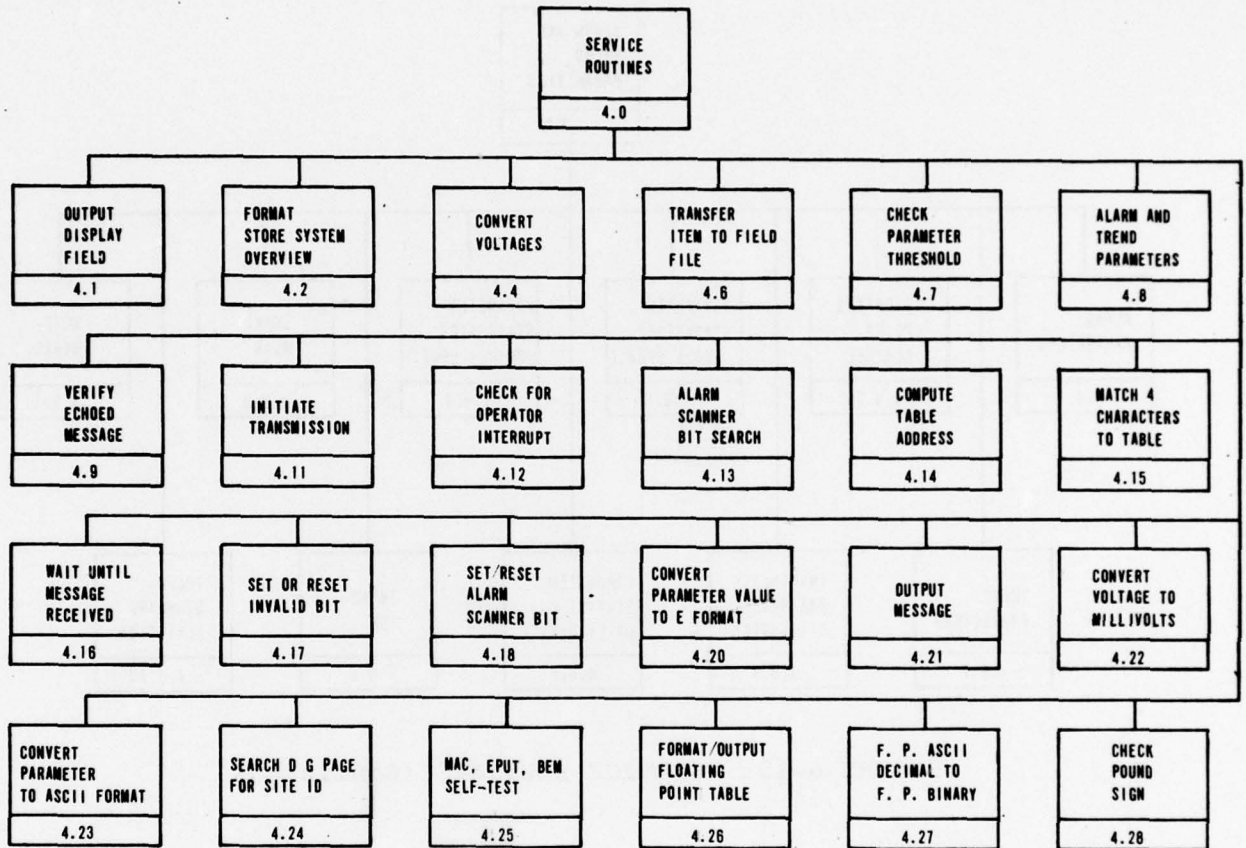

FIGURE 6-15. SERVICE ROUTINES

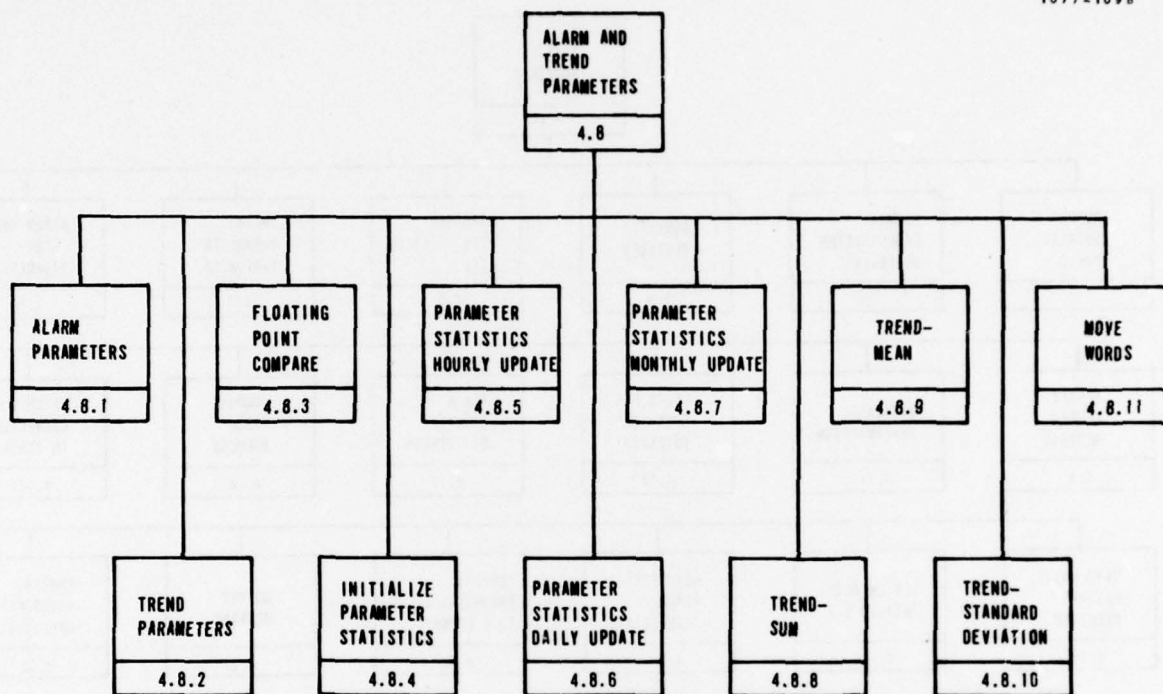

FIGURE 6-15. SERVICE ROUTINES (Continued)

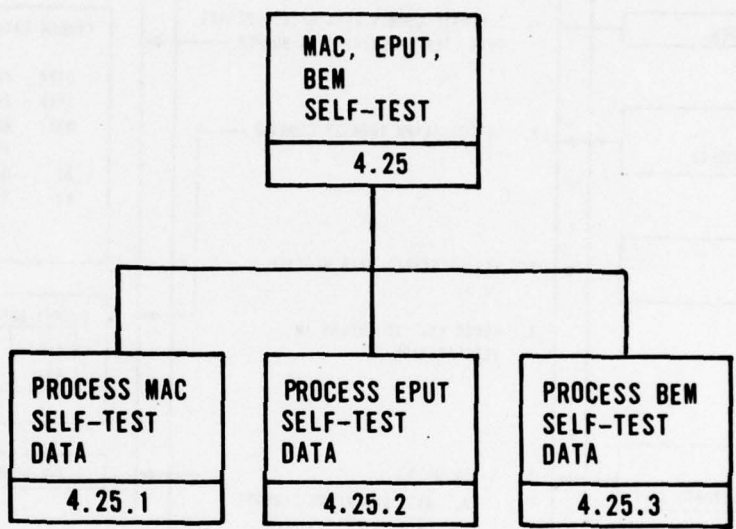

FIGURE 6-15. SERVICE ROUTINES (Continued)

HIPO NO.: 1.3

AUTHOR: DTD

DATE: 7/27/76

1077-227H

TITLE: Input Alarm Summary Data

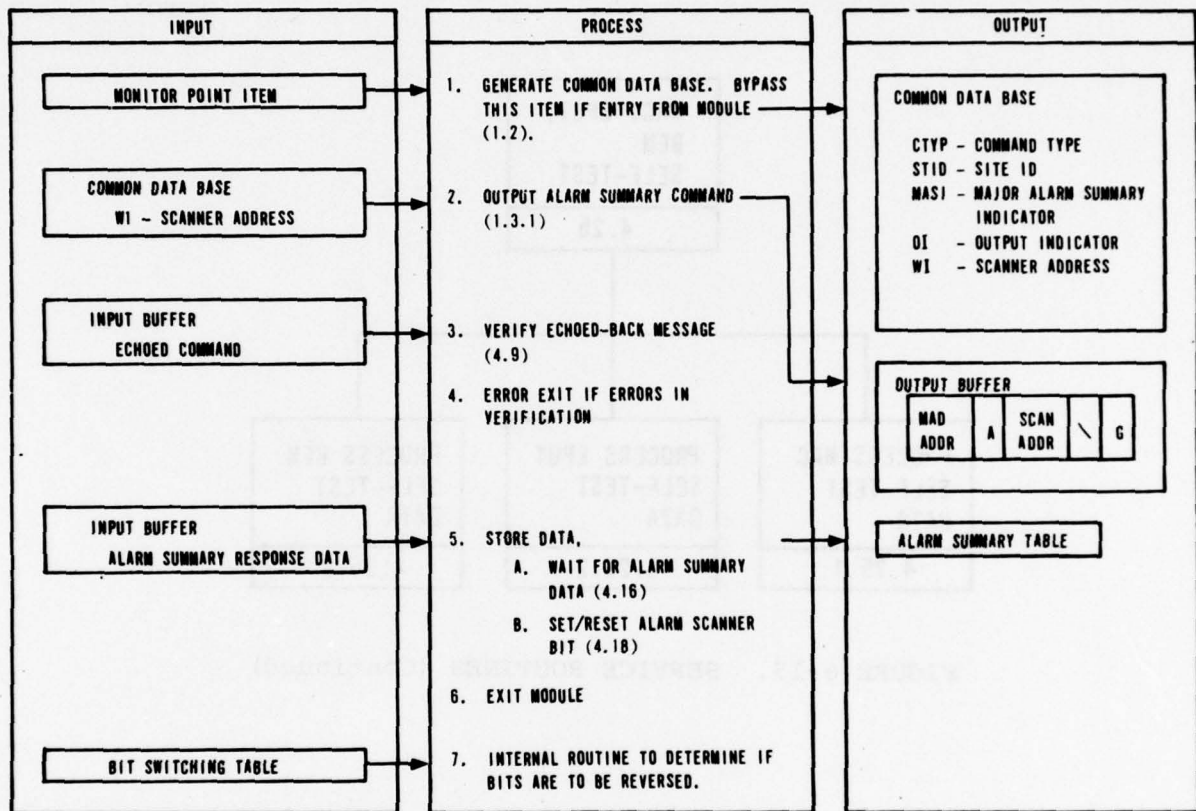

FIGURE 6-16. HIPO DIAGRAM

The software and data structure described in the hierarchy and HIPO diagrams allow for quick isolation of software problems. As an example, Figure 6-17 summarizes the HIPOs for the nodal control scan module (1.0). The input modules (1.1 through 1.4) get data from the monitoring devices (MAD, MAC and IQCS) and store it in the alarm scanner table, the site voltage table and the VF table. The processing modules (1.5) use the data in these tables for computing, trending and alarming parameters. The results of this processing is stored in the parameter value table, statistics tables, and alarm trend tables, respectively. The display modules use all the above tables for creating display presentations. By having a set of tables between the input, processing and display modules, one merely has to interrogate the tables to isolate the set of modules causing the problem. The logic used in this process is described in the following example of "Pseudo Code".

If alarm scanner problem

 If alarm scanner table tracks alarms

 check display modules

 Else

 check alarm scanner input modules.

If parameter value problem

 If voltage in site voltage table does not agree with observed

 check voltage input modules

 Else

 If parameter value agrees with computed value

 check display modules

 Else

 check processing modules.

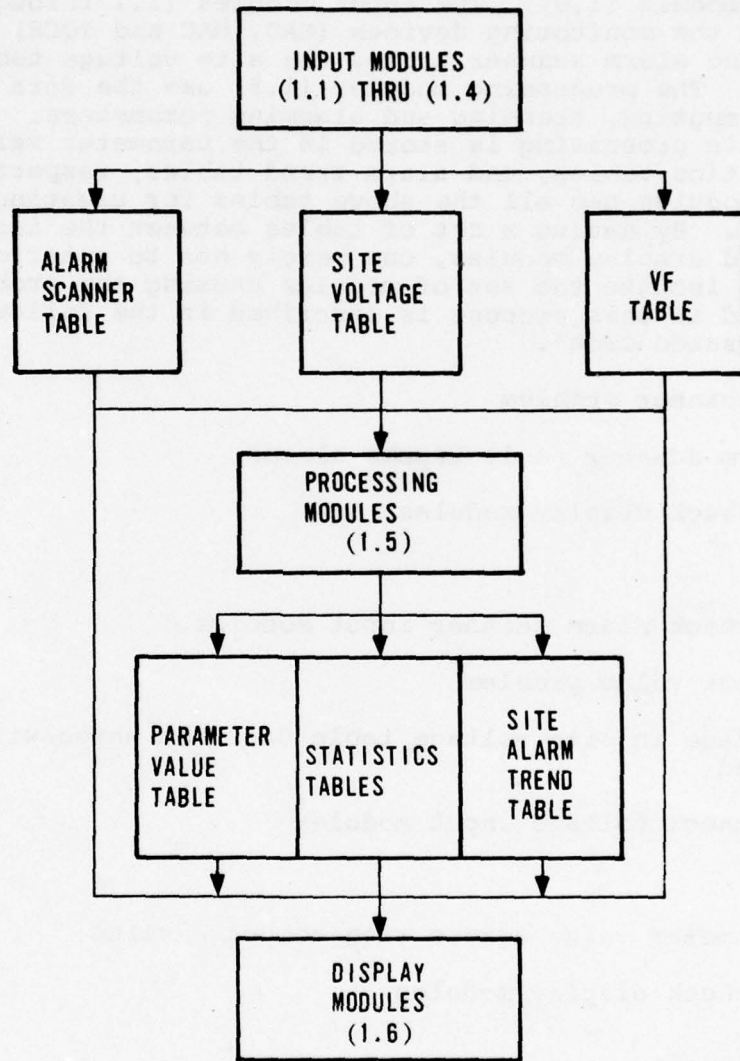

FIGURE 6-17. NODAL CONTROL SCAN MODULE

6.2.2 Adequacy of Software Debugging Aids to Provide Information that is Useful in Error Detection and Tracing

Software Development and Debugging

The PATE system has 16,384 words of core storage. Approximately half of this is used by the PATE executive and associated software. This code is in core all the time and is known as resident core. The remaining 8K of core is available for applications programs. If an application requires more than 8K it must be partitioned into 8K sections, each being brought into core and executed in a sequential manner.

The digital ATEC software requires more than 8K to satisfy all its requirements. It was partitioned as follows:

1. Nodal Control Scan Task. Module 1.0, associated modules, service routines and PATE utility routines.
2. Nodal Control Operator Interaction. Module 2.0, associated modules, service routines and PATE utility routines.
3. Output Display Task. Module 1.6, associated modules, service routines and PATE utility routines.
4. DATEC Self-Test Task. Modules 4.25, 4.25.1, 4.25.2, 4.25.3, service routines and PATE utility routines.
5. Data Base Generation Program. A utility routine that allows accessing and changing floating point numbers.

Each of these tasks is represented by a punched paper tape which can be loaded onto the PATE disk by means of the TermiNet tape reader. These tapes are generated in the software development facility (SDF) in the plant at Honeywell. This development process is illustrated in Figure 6-18.

Each module is coded, punched on cards (1) and placed in a library of source files on the disk (2) in the SDF. Once a source file is on disk, it can be changed or corrected by entering correction cards (3) on to a disk update file (4). This file is in turn used by the source update program (5) to modify the disk source file (2).

The assembler program (6) reads a specified source file (2) and generates an object file (7) which can be read by the loader. It also generates a program listing of the specified module which is kept in a binder for reference purposes.

After all modules making up a task are in the object file state, a paper tape can be generated. This is done by entering a card deck (10) of source file names making up the task. The

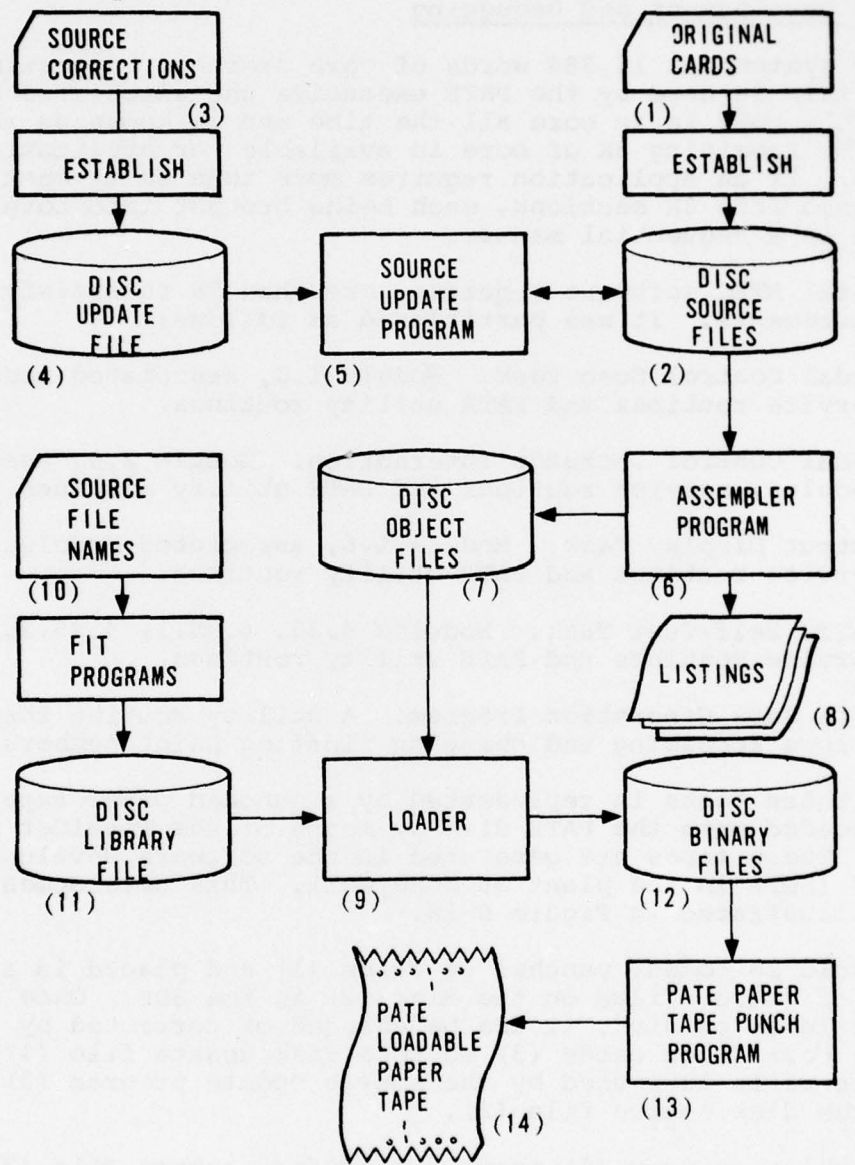

FIGURE 6-18. SOFTWARE DEVELOPMENT PROCESS

fit programs search all source files in this list to determine their respective sizes and generates a disk library file (11) consisting of the object file names in the order that they are to be loaded. This file is ordered by the fit programs so as to minimize cross sector linkages. The loader program (9) loads the object files (7) as specified by the disk library file (11). The output of this loading process is a binary file (12) placed on the disk. The data in this file is in core image format which can now be read by the PATE paper tape punch program.

The debugging process used on the host computer both in-plant and in the field is shown in Figure 6-19.

The paper tapes generated in the SDF are loaded onto the PATE disk by means of the termiNet loader program (1). Corrections can be made to the PATE disk without new tape generation by means of the Patch program (2). With this program, a programmer can bring a task into core, make changes to it and have it written back to disk. This provides a rapid means of making module changes and testing them on the host computer. Once a change is made in this manner, the task on the disk is no longer the same as the paper tape that was originally loaded. During debug the programmer therefore records all patches in a software log book (5) specifying the module name and task name. If for any reason a task is destroyed on the disk the programmer just reloads the paper tape and reenters all patches recorded in the log book to recover.

During in-plant debugging when the SDF was in close proximity, one or two pages of patches were accumulated in the log book before the source files were updated and new tapes generated. In general, programmers tended to keep paper tapes as current as possible.

Debugging in the field was handled a little differently since the SDF was not available. The patch program was used extensively to make corrections and modifications. These were carefully recorded in the software log book. In addition, a disk backup system was used. The PATE disk has a fixed disk and a removable disk. These two packs contain the same information. When a task is patched it is written to both the fixed and removable disks. A three disk cycle was used to save information and provide backup capability. After patching a task the removable disk is taken off the drive and replaced by the oldest disk in the cycle. The disk utility program (4) is then used to copy the fixed to the removable. If the disk was ever destroyed, the latest backup could be used to restore the system.

The software development and debugging procedures described were quite effective in both in-plant and field checkout. They were simple to use and learned in a minimum amount of time by new programmers. The many software improvements, some quite

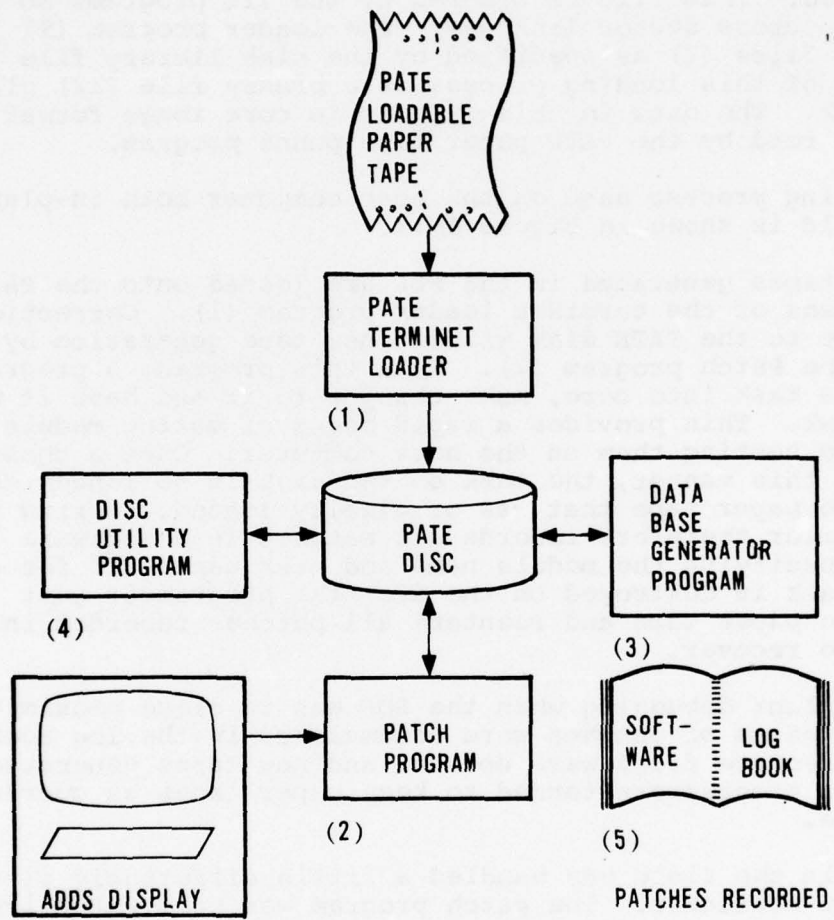

FIGURE 6-19. IN-PLANT AND FIELD CHECKOUT PROCESS

extensive, would not have been possible without these techniques. During the length of testing at Ft. Huachuca, there was no time lost because of software problems. This can be directly attributed to the debugging and backup procedures used.

6.2.3 Usefulness of Error Messages and Diagnostics that are Provided When the System Fails

The PATE and Digital ATEC software was designed to prevent catastrophic software problems due to system failures. These problems usually occur because of the inability of the software to respond to bad data entered as a result of system failures. Data is input to the Digital ATEC software through the data line controller (DLC) representing MAC/MAD inputs, the ADDS/TERMINET in the form of operator interaction and program loading, and the disk representing task loading and data file input. The software has provided protection in all these input areas as follows:

1. Data Line Controller. The upper left hand corner of the ADDS display has been reserved for the scan status and error messages. During the scanning process the latest command is printed on line one and line two shows the results of the command. No printouts indicates no problems. The message MAX RETRANS indicates that the command was transmitted three times due to garbled data or error responses from the MAC or MAD before going to the next command. The message NO RESPONSE indicates that expected data has not been received.

These messages proved to be quite useful during field testing. The line one message gave the operators an indication of where the system was in the scanning process and if a message occurred on line two it usually indicated that the device commanded was inoperative. It is important to note that the presence of an error message did not halt the software, cause it to go into an infinite loop, or allow bad data to enter the data base. The problem is merely noted and then the next command is selected.

2. ADDS/TERMINET. Data is entered through the ADDS during operator interaction. The error messages were found to be adequate during operator inputs. The most common message was ERROR. Although this is a general message meaning that the command was entered incorrectly, it was observed that the operators had no problems determining their errors when it occurred. The next most common error was FLOATING POINT VALUE IN ERROR, which usually meant that the decimal point was left out in entering floating point data.

At no time during field test did an erroneous input by the operator cause catastrophic software problems. There was one minor problem encountered when the new Monitor

Immediate code was entered in the field. The operator entered a starting item that was greater than the ending item which caused Monitor Immediate to go into an infinite loop. This was corrected in the field.

3. Disk. Software tasks and data are constantly being loaded into core from the disk and updated data bases are being written to disk during normal operating conditions. If the disk fails software must be available to prevent corrupted data from entering memory or being written to disk. The PATE operating system provides for disk error detection by checking the disk hardware status after each read or write operation. If an error occurs, the software attempts to recover by copying the fixed disk to the removable. If this cannot be done, the message ERROR DURING COPY is printed and the operator is given the choice of repeating the operation or fixing the disk. This error message occurred twice during field testing. Once when a software bug caused the disk to be reformatted, and a second time when the disk failed. The disk diagnostics were run for the disk failure and pointed out that the disk was experiencing sector mismatches. This eventually led to replacement of an option card in the disk.

6.2.4 Ease With Which Software is Debugged Both On-Site and at the Honeywell Plant

There were a total of 54 software and data base changes made during field test operations. Only nine of these changes were because of bugs. The rest were either to improve the existing software or to add a new feature that was overlooked in the original design.

Following is a description of the nine software bugs and how they were isolated and corrected.

Bug No. 1. Bad eye hits calculation. This bug was manifested as an eye hit value on the link status display that was grossly higher than expected. The debugging technique described in Paragraph 6.2.1 was used to isolate the problem to the calculation modules, in particular, module 1.5.4 (Process Eye Hit Voltages). In checking the calculation of the eye hit rate, it was found that the time base constant for the BEM EPUT was entered as an integer number instead of floating point. This was corrected with the use of the data base generator program (DB). The bug was detected and corrected within 10 minutes.

Bug No. 2. Loss of hourly statistical data when new day begins. This bug was detected while observing the statistics collected during an overnight test run. It was noticed that the RSL scan count was normally 15 or 16 for each hour in a 24 hour period except for the hour just after midnight. Its value for this hour was one. This immediately led one to believe that there was a problem in the trending module in the area of determining when an hour had elapsed. By tracing through the hierarchy and HIPO diagrams, it was found to be module 4.8.2. The problem was corrected by using the PATCH routine. It took approximately one hour to detect and correct the problem and another 24 hours test run to verify the fix.

Bug No. 3. Erroneous data printed during access of system statistics. This bug was detected while accessing system statistics with operator interaction. It was observed that when the hourly, daily, monthly or 30 month values were requested a second time for the same parameter that they would be different from the first. By tracing through the hierarchy diagram for nodal control operator interaction, it was found that module 2.13.4 performed the function of accessing system statistics. In checking the code it was found that the parameter number was not being reinitialized properly for multiple requests for the same parameter. The module was corrected with the patch routine. This problem was detected and corrected in approximately 25 minutes.

Bug No. 4. Incorrect Eye B Availability calculation. This bug was detected when it was noticed on the Link Performance Assessment display, Page 1, that the Eye Availability for the B radios at both sites did not change when expected. The isolation technique previously described was used to determine that the display modules were at fault. It was found in tracing through the hierarchy diagram for module 1.6 that module 1.6.4 processes the Link Performance Assessment display. It was found upon inspection that the display generator table driving the module had incorrect pointers to the B Eye Availability parameters. The correction was made with the patch routine. Total time to isolate and correct the problem was approximately 10 minutes.

Bug No. 5. Alarm color not determined properly. This bug was detected when it was observed on the Link Status display, Page 1, that the alarm color for the Eye Amplitude parameter was not being determined properly. This parameter used alarm threshold number 14. Other parameters with threshold indicators less than 14 were being alarmed properly. Since there are 14 sets of alarm thresholds per disk page, it was concluded that there was probably an error in the disk page number calculation in module 4.8.1 (ALARM PARAMETERS). This proved to be true upon further investigation. The problem was corrected with the patch routine. The total time to detect the problem, correct it and verify the fix was approximately 45 minutes.

Bug No. 6. Clobbered disk problem. This problem was detected as disk errors during normal operation. Attempts to restart the system failed, indicating that the disk had been clobbered. The system could be restored only by copying the fixed disk to the removable. The problem first appeared to be intermittent in nature, but upon further investigation of memory when the problem occurred it was found that module 1.0 was in core and that the trending module (4.8.2) was the last module called. It was finally determined that the problem occurred when the current day and time were less than the start day and time for statistics. Knowing this, the problem could be made to occur at any time. By using the patch program to place halts in the program flow, the problem was finally traced to two modules (4.8.9, TREND MEAN, and 4.8.10, TREND STANDARD DEVIATION) which had improper returns in an area of code entered as a result of the problem perturbation. The detection and correction of this problem took approximately two hours after it could be made to occur at will.

Bug No. 7. Computer halt problem. This bug was detected when the computer halted in the floating point multiply routine. This is a PATE routine used in ATEC software. It was found that the routine was coded to halt when an underflow condition occurred in the floating point accumulator. This was changed using the patch routine to return a zero instead of halting. The time to detect and correct the problem was approximately 15 minutes.

Bug No. 8. Improper maintenance voltages. This bug was detected when it was observed that the maintenance voltages for the T1-4000 were not being updated on the Maintenance Voltages display when fuses were pulled while the T1WB1 and radio voltages were changing as expected. The isolation technique previously described was used to determine that the problem was in the calculation modules (module 1.5.10, Process Maintenance Voltages). It was found that the data base file that drives this module had some incorrect pointers. These were changed with the patch program and the problem cleared. The total time required to isolate and correct the problem was 20 minutes.

Bug No. 9. Improper conversion. This bug was detected as an improper conversion of the floating point availability values. The conversion module 4.23 is supposed to convert to 5 significant figures. It was observed that values greater than 0.99328 were only being carried out to four significant figures. The problem was traced to an inaccurate conversion constant. This problem was detected and corrected within approximately 45 minutes.

6.2.5 Meantime for Detection/Isolation of Software Errors

The following is a summary of the approximate times for detection/isolation of software errors previously discussed in Paragraph 6.2.4:

<u>*Bug No.</u>	<u>Time to Detect/Isolate (Minutes)</u>
1	3
2	20
3	15
4	3
5	20
6	80
7	10
8	13
9	10

This results in a meantime for detection/isolation of 19 minutes for each software error.

6.2.6 Meantime to Modify the Code When Corrective Action is Required

Following is a summary of the times required to modify code when corrective action was required as a result of the software errors previously discussed in Paragraph 6.2.4:

<u>*Bug No.</u>	<u>Time Required to Correct (Minutes)</u>
1	7
2	40
3	10
4	7
5	25
6	40
7	5
8	7
9	35

This results in a meantime for code modification of 20 minutes for each software error.

* No. assigned in Paragraph 6.2.4.

6.2.7 Extent to Which Software Modification and Checkout is Required

Following is a summary of the modifications made to the software and bugs found and corrected. A description of the change and a reference to the software data book (included as Addendum 2 to the Field Test and Evaluation Report) containing the actual patch is given. Those items marked with an asterisk (*) are the software bugs found.

FIELD CHANGES TO DATEC SOFTWARE AND DATA BASE

1. Modified data base (DG, PD) to accommodate alarm scanner hardware change. (18, 19, 20, 21 switched to 20, 21, 18, 19) Data Book 1159, page 87.
2. Patched operator interaction (CN) to allow scanning during LPA and maintenance displays. Schedules NT following OD. Patched TV to bypass operator interrupt code. Data Book 1159, page 88.
3. Provided flashing major alarm indication and audible alarm at the ADDS whenever major alarm is detected. Data Book 1159, page 89.
4. Patched TV to output a "format off" character (2378) whenever output display task is entered. Data Book 1159, page 90.
5. Patched NS to bypass display update for LPA and Maintenance Voltage displays. Data Book 1159, page 90.
6. Changed conversion factors in PD file for radio voltages from 0.004 to 0.003. Data Book 1159, page 90.
7. Changed name of maintenance voltage No. 2 to "T1WB1+12" for both HUA and SBL. Data Book 1159, page 91.
8. Changed low end of conversion table No. 1 from 0 to 11.587E-9 so that FER for 0 counts will come out 1.0E-15. Data Book 1159, page 91.
9. Eliminated Temporary Scan and added code to NS and CN to provide a Monitor Immediate capability. Data Book 1159, pages 94, 95, 96, 97.
- *10. Corrected eye hits bug by changing BEMN from integer 90 to floating point 90. Data Book 1159, page 95.
11. Changed units on LPA page 2 to VLTS in base display file, DF. Data Book 1159, page 98.
12. Entered Dispersion Voltage versus DER BER tables for HUA and SBL (Tables 8, 9, 14, 15). Data Book 466, page 1.

13. Set up IQCS monitor table for channels 5, 6, 7, 8. Data Book 466, page 1.
14. Entered RSL versus DBM tables for HUA and SBL (Tables 10, 11 4, 5). Data Book 466, page 1.
15. Modified alarm threshold No. 3 for +12 volt threshold. Data Book 466, page 1.
- *16. Corrected trending bug in NS. Data Book 466, page 2.
17. Set up Data Base for tests B, D and E. Data Book 466, pages 2, 3, 4, 5.
- *18. Corrected access statistics bug in CN. Was not reloading page for multiple parameters. Data Book 466, page 5.
19. Set up data base for test F. Data Book 466, page 6.
20. Entered new Table 6 (Dispersion Voltage to Eye Margin). Modified EDIS to accommodate new Table 6. Data Book 466, page 7.
21. Modified PD file to reference only Table 6 for Eye Margin. Data Book 466, page 7.
- *22. Corrected data base bug in DG file. Pointer to B Eye Availability was incorrect, HUA and SBL. Data Book 466, page 8.
- *23. Corrected bug in alarming module. Was computing page number incorrectly when loading alarm thresholds. Data Book 466, page 8.
24. Set up data base for test G. Data Book 466, page 9.
25. Patched TV to wait after display update to allow operator to print local without problem. Data Book 466, page 10.
26. Patched resident core (RC) to set a flag for the above patch when control W is entered at the keyboard. Data Book 466, page 10.
27. Set up data base for test J. Data Book 466, page 11.
28. Rearranged Monitor Immediate table. Data Book 466, page 12.
29. Patched resident core to provide enable/disable capability on ADDS major alarm audible alarm. Modified NS patch to check enable/disable flag before sounding alarm. Data Book 466, page 13.

30. Patched BEM self-test (TN) to print "90 sec time delay". Data Book 466, page 14.
31. Eliminated "DIF" from "BER COR DIF" field on Link Status, Page 1 display (DF base display). Data Book 466, page 14.
32. Modified Link Status, Page 1 and 2 displays to output "<1.0E-7" in FER field for T1-4000 and "<1.0E-6" in T1WB1 FER field when applicable. Also output "NO DATA" in "BER COR" field. Data Book 466, pages 15 and 16.
33. Set up data base for System Simulation Scenarios. Data Book 466, page 17.
34. Patched NS to alarm but not trend if reframe occurs. Data Book 466, page 18.
35. Patched TV to output 0 if maintenance voltage less than 10^{-5} , Data Book 466, page 19.
36. Patched TV to bypass outputting alarm data when "NO DATA" printed. Data Book 466, page 19.
37. Patched NS to clear major alarms (bits 1 through 5) before major alarm summary. Data Book 466, page 20.
- *38. Corrected trending bug in NS. Two routines (TMN and TSDV) omitted IRS before returning. Data Book 466, page 21.
39. Patched NS to output warning message if operator loads resident core without setting time. Data Book 466, page 21.
40. Changed IQCS scan table to eliminate major alarm summary. Data Book 466, page 22.
- *41. Corrected bug in NS (MS22 routine) that caused halt if underflow occurred. Data Book 466, page 22.
- *42. Corrected bug in PD file to reference correct maintenance bits. Data Book 466, page 23.
43. Patched TV and CN to insure that the requested site is continually updated on the Maintenance Voltage display. Data Book 466, page 23.
44. Patched NS to OR (i.e., if any channel amber or red) IQCS channel measurements together for LS, Page 2 field. Data Book 466, page 24.
45. Revised statistics patch to correctly calculate hours elapsed since start of statistics. Data Book 466, page 25.

46. Patched TV to reset FLG1 for "NO DATA" print out if "INVLD" exit taken. Data Book 466, page 26.
47. Patched NS to omit in-service check on T1-4000 when in Monitor Immediate mode. Data Book 466, page 26.
48. Changed item 5 of Monitor Immediate table to perform major alarm summary after voltage measurement. Data Book 466, page 27.
49. Changed end point in Table I (Voltage to Mean Count) to reflect new EPUT time base. Data Book 466, page 27.
50. Changed alarm threshold No. 13 (Eye Margin threshold). Data Book 466, page 27.
51. Revised patches on pages 15 and 16, Data Book 466 to reflect increased EPUT time base (from 120 to 210 seconds). Data Book 466, page 28.
- *52. Corrected bug in conversion routine %SPARC that would not create 5 significant digits for numbers greater than 0.99328. Data Book 466, page 28.
53. Changed operator interaction scheduler to schedule NC to resume scan when time out occurs. Data Book 466, page 29.
54. Patched statistics to retain data points used to compute hourly means. Data Book 466, page 30.

6.2.8 Degree to Which the Software is Machine Dependent

The Digital ATEC software is written in machine language and is therefore restricted to the 316 computer. It should be pointed out though, that because of the highly visible documentation provided through the use of structured programming techniques, it would be a fairly easy job to provide the nodal control capability in a higher order language.

6.3 ADDITIONAL EVALUATION CONSIDERATIONS

In addition to those items specifically delineated in the S.O.W. which were to have been addressed during field test operations, there were several other topics recommended by RADC for consideration. These topics fall primarily into two groups. The first is directed toward the impact upon skill levels or manning which DATEC might have. The second group is concerned primarily with certain aspects of DATECs output display formats.

6.3.1 Manning Structure

One of the objectives of the DATEC field test was to examine the manning structure required to support a DATEC monitored PCM system cluster. Key manning questions directed towards this area are as follows:

- In what manner can the DATEC system save O&M personnel?
- Assuming some stations were unmanned, determine if and what additional skills or extra manning would be needed at a manned facility providing control of the unmanned site.
- What complement of "five-level" technicians (Air Force Specialty Code Experience Level-5) would be needed to support a total nodal jurisdiction with 16 subordinate stations connected to it?

These questions are addressed in detail below.

6.3.1.1 DATEC System Versus O&M Personnel Requirements

The use of remote monitoring and assessment equipment such as DATEC will result in O&M personnel savings. This is supported by several facts:

- a. Due to accurate on-site monitoring and remoting of System/ Equipment parameters and status information to a centralized nodal control station, the need for manning of remote facilities is greatly reduced. This is not totally facilitated by the advent of DATEC but represents a general improvement in facility state of the art equipment design and reliability. This general improvement is enhanced by DATEC allowing the reduction in support manning as discussed below.
- b. Since facility performance information is centrally collected and trend analyzed at the nodal control station, the O&M support personnel resources (Maintenance and Operations) can be collected and more efficiently centralized for dispatch to the remote sites as required.
- c. Through the use of trend analysis techniques some scheduled maintenance routines at remote sites can be eliminated or their frequency decreased thus reducing maintenance dispatch personnel requirements.

For example, a hypothetical maintenance routine (Preventive Maintenance Instruction) number 31R5-2FRC163-WC-X, Instruction 3.1, may require 1.6 hours per radio rack each week to perform. The objective of the PMI is to measure all power supply voltages in the radio rack, to ensure they are within tolerance. With

16 sites and 2 radio racks per site, this would be 16 x 2 x 1.6, or 51.2 manhours per week just to measure the power supplies.

DATEC could measure all power supply voltages each maintenance scan, and analyze them against tolerance objectives. In addition, trend limits are established to detect variations that can lead to radio failure. This further reduces routine frequency/manpower requirements as the maintenance dispatch takes on the actual Radio MTBF performance. Dispatch, travel and on-site maintenance time could be reduced to 1/4 its current practice.

A case in point is the maintenance support time required for the unmanned facility at Christmas Common England. The AN/GRC-185 radio requires 120 scheduled manhours monthly and results in four 60-mile round trips requiring 2.4 hours each to and from the dispatch center at Hillingdon. This results in a total of 129.6 scheduled manhours per month. DATEC type monitoring could reduce this total to 33 scheduled manhours a month, eliminating the need for scheduled weekly routine trips to measure voltages and so forth. It is realized that the GRC-185 is an older radio with a lower MTBF than that predicted for the AN/FRC-162 and 163, but is used here only as an example.

6.3.1.1.1 Summary

The field test demonstrated DATEC's ability to measure, collect and analyze system/equipment parameters and status information. The manpower savings that can be recognized through automated instrumentation is not that demonstrable due to the lack of established performance data, maintenance routines and manning data for DEB-FKV facilities. In the maintenance area alone, it can be assumed that based on current maintenance and manning practices that the need for manpower can be reduced as facilities are installed for unattended operation.

This assumption is based on the willingness of the services to allow instrumentation and remote monitoring of facilities/equipment parameters to replace the existing scheduled maintenance approach.

In the technical control area, it has been estimated* that a 20 percent reduction in control personnel can be recognized through automating technical control functions. This figure includes the addition of ATEC operations personnel (Sector & Nodal), and is supportive to the Defense Communications Engineer Center estimates contained in DCEC Technical Note 5-75.

* ATEC Cost-Effectiveness Analysis, Honeywell ID Project F8545, Ewing, R.D., Peters, G.L., Tufaner, R.L. Systems Research Center, 7 March 1977.

6.3.1.2 Additional Manning - Skills Requirements

With the unmanning of some subordinate sites, and the centralization of both operational and maintenance functions at the nodal location, additional personnel will be required to support the unmanned facilities. It is not the objective of this discussion to provide a detail manning standard for the 16 station node, but to provide a general synopsis of manning and skill considerations.

- a. ATEC Maintenance. As a minimum, two ATEC maintenance technicians will be required per node. Their duties include the support and maintenance of the nodal equipment and remote station equipment. The geographical size and separation of the 16 stations within the node may require additional personnel. This may result in the creation of dispatch work centers at selected non-nodal sites to support unmanned facilities which are geographically too far from the nodal station to offer responsive maintenance support.
- b. Equipment Maintenance (AFSC 304XX-FC2659D). The number of radio wideband maintenance personnel required to support the 16 station node fall under the same geographical constraints addressed above, and are difficult to predict. The lack of DEB-FKV performance data or an appropriate manning standard for that type of equipment further complicates the prediction task. Based on past manning practices, and ignoring geographical constraints, it is recommended that 0.75 man authorization be added to the nodal maintenance workcenter for each unmanned site support. Minimum dispatch workcenter manning is two technicians (as per AFCSR26-3, Manpower Standards, 15 May 1975). It should be noted that geographical separation, travel time, and mission response may require increasing the recommended man authorization to as high as 1.35 man authorization per unmanned site.

6.3.1.3 Five-Level Technician Requirements

"Five-level" skill technician manning throughout the technical control and radio maintenance career field is approximately 52 percent (average) the total manning authorization for the given Air Force specialty code (AFSC). It is recommended that this mix be continued and applied to the total manning requirements derived in 6.3.1.2 above.

6.3.2 DATEC Output Display Considerations

This second group of items addresses three questions regarding DATEC's output displays:

- How might a particular display provide indications of escalating troubles?
- How may DATEC displays be adjusted or modified so that they can be restructured in a manner to suit the needs of a maintenance technician, a technical controller, or a squadron level management control function?
- How may DATEC be adjusted to total link outages such that a cascade of alarms will not occur?

6.3.2.1 Escalating Troubles

The System Overview display provides all the information that is required to detect and trace a developing problem. Any abnormal condition of the equipments in operation on a link will be reported on this display. Only discrepant status is displayed. If there are no problems, there are no entries in any of the fields. A parameter which is out of tolerance is indicated by an "A" (amber) flag symbol in the field of the discrepant equipment. A hard alarm, indicating that a particular piece of equipment has failed preset limits within the device itself, is indicated by a "R" (red) flag symbol. An escalating problem, then, might start out as a degrading parameter which would first receive an "A" notation. When the problem developed to the point that equipment operation was severely impaired and an alarm was generated by that equipment, the status flag would change to "R". A few examples of this were obtained during field tests. There were not too many because generally, when the amber condition was noted on the System Overview display, the technical controllers went immediately to a lower display such as Link Status or Link Performance Assessment in attempting to isolate the cause. One good illustration, however, of an escalating trouble was noted in the Appendix U scenario conducted on 20 June 1977 (refer to pages 291 through 300). In this scenario, frame errors are caused in both the T1WB1 and T1-4000 by blanking the received baseband from the radio using a special piece of test equipment. The length of the blanking pulse and therefore the severity of the problem could be varied. As will be noted, from the two System Overview displays printed out at 0843 and 0846, the problem is severe enough to cause a parameter (FER) alarm by exceeding preset limits in DATEC software. The next two displays printed out at 0847 and 0852 indicate that the problem has now progressed to the point that an equipment alarm (T1-4000 Switch Major) has occurred and the amber flag on System Overview has changed to red.

6.3.2.2 Modification of DATEC Displays to Meet Functional Needs

Figures 6-20 and 6-21 illustrate recommended System Overview and Link Status displays that satisfy technical controller's needs. These were described in the trip report on testing the Digital Automated Technical Control at Fort Huachuca dated 9 August 1977 written by 1st Lt. Chris M. Sandifer and T. Sgt. Robert R. Reinke. These displays could be implemented quite easily with the Digital ATEC software principally due to its modular design. Figure 6-22 shows the data structure of the output display software. The software is driven by two disk files, the display generator file and the display fields file. The display generator file contains all information required by the software to generate the fields for a particular display. The display fields file contains the fixed and variable fields that actually make up the display. When a display is generated, the applicable processing software reads the records from the display generator file to determine where to find data in the data base for generating the display fields. Once they are generated, they are written into the variable fields of the display fields file. This file is then read and transferred to the ADDS CRT by the software. In order to restructure a display, it involves only restructuring the order of data in the two disk files. If new fields are desired, it involves entering new data in the files and writing new software for generating the new field.

With similar information from maintenance or squadron level management personnel, displays satisfying their requirements could be implemented in a similar manner.

6.3.2.3 Display Adjustment to Prevent Alarm Cascading

Currently, DATEC software reports all alarms received from a MAD and blinks the highest major alarm received. If a total link outage occurs, what will be seen on the overview display will be a blinking Rx problem for the radio and red alarms for the MUX switch, the T1-4000, the T1WB1 and the CY-104. It is a trivial problem to modify the overview display processing modules to refrain from processing the lower level equipment fields if a Radio Rx major alarm occurs. This modification requires less than 10 words of code.

<u>SCAN NO.</u>	<u>SYSTEM OVERVIEW</u>			<u>TIME</u>	
<u>LINK NO.</u>	<u>RADIO</u>	<u>HIGH LEVEL MUX</u>	<u>LOW LEVEL MUX</u>	<u>SITE</u>	<u>TELEMETRY</u>
Mxxxx					
Mxxxx					
Mxxxx					
Dxxxx					
Txxxx					
Sxxxx					

FIGURE 6-20. RECOMMENDED OVERVIEW DISPLAY

<u>SCAN NO.</u>	<u>Mxxxx LINK STATUS</u>				<u>TIME</u>
	<u>RADIO</u>		<u>T1-4000</u>		
	<u>SITE #1</u>	<u>SITE #2</u>	<u>SITE #1</u>	<u>SITE #2</u>	
Tx A			Tx PROB		
Rx A			Rx PROB		
Tx B			Sw MAJOR		
Rx B			Sw MINOR		
			MAJOR		
Rx SQUELCH			Tx IN SVC		
RSL MARGIN A			Rx IN SVC		
RSL MARGIN B			MAINT		
Tx EYE MARGIN A			XMIT FER A		
Rx EYE MARGIN A			RCV FER A		
			CRFRM A		
Tx EYE MARGIN B			XMIT FER B		
Rx EYE MARGIN B			RCV FER B		
			CRFRM B		

FIGURE 6-21. RECOMMENDED LINK STATUS DISPLAY

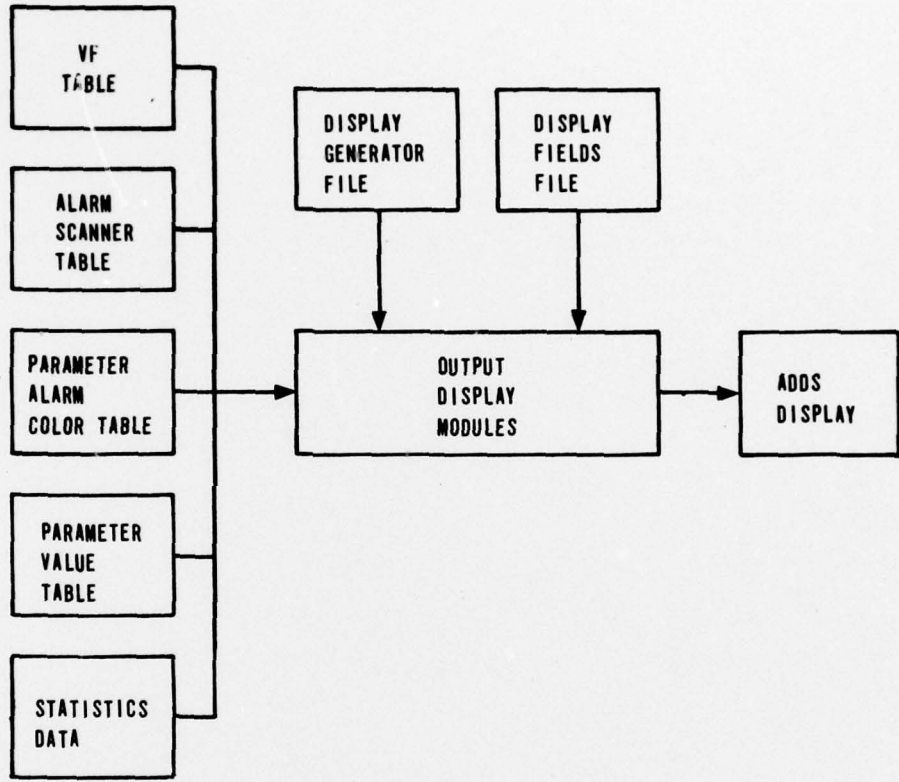

FIGURE 6-22. OUTPUT DISPLAY SOFTWARE/DATA STRUCTURE