

①

AD A051953

FOREIGN TECHNOLOGY DIVISION



MEANS OF DEFENSE FROM PRODUCTION NOISE

by

A. S. Palashevskaya

DDC
RECEIVED
MAR 30 1978
RECEIVED
F

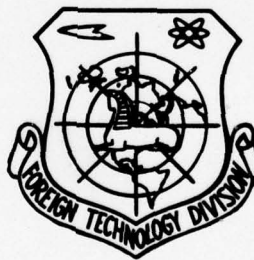

Approved for public release;
distribution unlimited.

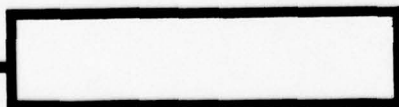

TABLE OF CONTENTS

U. S. Board on Geographic Names Transliteration System and Russian and English Trigonometric Functions.....	11
Preface.....	2
Introduction.....	5
Physical Nature of Sound (Noise).....	8
Physiological Effect of Industrial Noise of the Human Organism.....	31
Production Conditions.....	60
Instruments Procedure of the Measurement of Production Noise.....	73
Normalization of Noise Level in Production.....	85
Collective and Individual Protective Means from Production Noise.....	91
Technical Requirements with Respect to Noise Abatement of New Machines and Mechanisms.....	157
Technical Specifications of the Planning of Noisy Productions.....	163
References.....	183

U. S. BOARD ON GEOGRAPHIC NAMES TRANSLITERATION SYSTEM

Block	Italic	Transliteration	Block	Italic	Transliteration
А а	А а	A, a	Р р	Р р	R, r
Б б	Б б	B, b	С с	С с	S, s
В в	В в	V, v	Т т	Т т	T, t
Г г	Г г	G, g	У у	У у	U, u
Д д	Д д	D, d	Ф ф	Ф ф	F, f
Е е	Е е	Ye, ye; E, e*	Х х	Х х	Kh, kh
Ж ж	Ж ж	Zh, zh	Ц ц	Ц ц	Ts, ts
З э	З э	Z, z	Ч ч	Ч ч	Ch, ch
И и	И и	I, i	Ш ш	Ш ш	Sh, sh
Й й	Й й	Y, y	Щ щ	Щ щ	Shch, shch
К к	К к	K, k	Ъ ъ	Ъ ъ	"
Л л	Л л	L, l	Ы ы	Ы ы	Y, y
М м	М м	M, m	Ь ь	Ь ь	'
Н н	Н н	N, n	Э э	Э э	E, e
О о	О о	O, o	Ю ю	Ю ю	Yu, yu
П п	П п	P, p	Я я	Я я	Ya, ya

*ye initially, after vowels, and after ъ, ь; e elsewhere.
When written as ë in Russian, transliterate as yë or ë.

RUSSIAN AND ENGLISH TRIGONOMETRIC FUNCTIONS

Russian	English	Russian	English	Russian	English
sin	sin	sh	sinh	arc sh	sinh ⁻¹
cos	cos	ch	cosh	arc ch	cosh ⁻¹
tg	tan	th	tanh	arc th	tanh ⁻¹
ctg	cot	cth	coth	arc cth	coth ⁻¹
sec	sec	sch	sech	arc sch	sech ⁻¹
cosec	csc	csch	csch	arc csch	csch ⁻¹

Russian English

rot curl
lg log

Page 1.

MEANS OF DEFENSE FROM PRODUCTION NOISE.

A. S. Palashevskaya.

Page 2.

In pamphlet is determined the local and common/general/total effect of noise on the human organism, is given the concept of "threshold of audibility", "pain threshold", a logical-hygienic boundary of auditory perceptions, and also are given the maximum permissible norms of the peak values of noise for different frequencies in production locations and design bureau.

Special attention is devoted to the description of organizational, technical, health and hygiene measures and means of collective and individual protection, which lower the harmful effect

of the different production noise sources on the human organism.

Pamphlet is intended for the wide circle of the technical engineering workers of enterprises.

Page 3.

PREFACE.

The level of production noise is one of the most important indices of the standard of production.

However, frequently to a reduction in the production noise in number of the branches of the industry of proper attention it is not given. Mechanical engineers insufficiently utilize in the constructions of machines new natural and artificial nonsonorous materials, the noiseless energy sources and other means, which are found in the order of contemporary science and engineering. As a result the mechanisms become themselves the sources of the emergence of the high-frequency production noise which, acting on the organism of worker, are caused occupational diseases.

To fight with production noise pay great attention many medical institutions.

In the institute of the hygiene of work and occupational diseases of the Academy of medical sciences of the USSR, is carried out composite research on the physical nature of production noise and acoustic laws, which explain the physiological and psychological effect of noise on the human organism. Are reveal/detected and are studied the basic reasons for the noise formation of separate aggregate/units in production, is determined communication/connection of the audio frequencies of the production spectrum with technical reasons, are develop/processed measures for the elimination of the reasons for sound formation and propagation of emission/radiation.

On the basis of the data of physiological investigations of the safety of acoustic perception, the institute produces the estimation of effectiveness of the utilized in industry and newly developed/processed attachments for the protection of the organ/controls of audition, and also are estimated the results of the execution of different technical and sanitation measures.

Large work on research on the physiology of auditory organ/control fulfilled the blade of eye/ear, throat and nose, led by Prof. V. I. Voyachek (military medical academy), which determined role and the value of the common/general/total auditory-perception

function of organism, air and bone conduction of auditory perception, and also the role of diffuse ability and electrical phenomena, occurring with sonic perception.

Page 4.

Works on fight with production noise are carried out also in the scientific research institute in honor of Erisman, in the physical institute of the AS USSR, the institutes of industrial safety measures VTsSPcrs [All-Union Central Trade-Union Council] and its branches.

In the Leningrad institute of industrial safety measures (LIOT) are designed the instruments for level measurement of noise and its analysis under production conditions, are developed effective organizational and technical recommendations regarding fight with production noise, and also "time/temporary sanitary norms and rules on the limitation of noise in production".

The academy of architecture of the USSR and the academy of municipal services solve the problem of the rational acoustics of the special-purpose buildings, and also work on the projects of the reconstruction of habitable and industrial buildings for the target/purpose of an increase in them vibration- soundproofing.

Measures for noise abatement are develop/processed also by different boards, organizations and enterprises.

But the separate branches of machine-building continue to pour as before into production the flows of the mechanisms, which are intense noise sources.

This position it is not possible to consider normal.

The future of machine-building - these are the noiseless or low-noise mechanisms, which eliminate the harmful effect of noise on man.

Page 5.

INTRODUCTION.

The disturbance/perturbation of the atmosphere in nature occurs as a result of a change in its temperature, heating either the coolings,, which is accompanied by the movement of the masses of air, or as speaking, in the appearance of the wind. Depending on the amount of the perturbation impetus, of the masses of air can be

soundless and imperceptible, if the length of its wave is great, but can be converted into the wind, the storm, hurricane, cyclone with electrical discharges and the unrolling/reelings of thunder, with rain or cloudbursts or the snow blizzards and other known to us atmospheric phenomena.

The perception of these atmospheric changes is received by us through sense organs. In particular clearly we distinguish the initial and final stages of separate phenomena, transitions from one phase to the next.

Sound transmission is connected also with formation/education in the atmosphere of the air waves which transfer sound from its source to the auditory organ/control of man - to eye/ear.

The sounds, which exceed the loudness level of normal human speech (shout, command/crew, collapse in mountains, waterfall, storm, etc.), affect the central nervous system of man, causing the appropriate conditioned reflex.

The noise of contemporary production generally considerably exceeds the loudness level of human voice, and by separate productions it exceeds even the boundaries of the physiological abilities of the organ/control of audition, leading to its depletion,

to regeneration and even ossification, but in certain cases for its instantaneous destruction, i.e., for final hearing loss.

However, noise exerts harmful effect not only on the organ/control of audition, but also on entire human organism. People, working under conditions of large production noise, usually complain to rapid fatigability, a headache, a reduction in the productivity, an involuntary increase of the reject in work. Practice shows that simultaneously with the advent of symptoms enumerated above occurs a series of functional changes from the internal organ/controls of the man: cardiovascular, digestive and other systems and the organ/controls, it would seem, not having direct/straight relation to the organ/controls of audition.

Page 6.

Is explained this by the destructive effect of production noise on cerebral cortex - the central organ/control of nervous system, which is higher leader and the distributor of all functions of the human organism.

This circumstance causes and especially emphasizes entire importance and the seriousness of fight with production noise.

PHYSICAL NATURE OF SOUND (NOISE).

The effect of perturbing force on solid, liquid or gaseous elastic body causes the mechanical oscillation/vibrations of particles within its substance. The fluctuations of particles in the form of emission/radiation are transferred to the ambient air medium and frequently are the reason for emergence and propagations in free-air conditions of the elastic air waves, received by us as sound.

This phenomenon is more easily present on any system of small mass and large elasticity: tuning fork, the rule, stopped up into jaws, to the stretched string, which under the effect of jerk/impulse, shock or another perturbing force, as a result of its elasticity long time continue to accomplish the so-called natural or free oscillations.

Equal in magnitude perturbing forces are caused in the body of the fluctuation of the determined force and frequency. With an increase in the perturbing force, increases the intensity of oscillations.

Equal in magnitude perturbing forces are caused in the body of the fluctuation of the determined force and frequency. With an increase in the perturbing force, increases the intensity of oscillations.

An increase in the mass of substance or a decrease in the elasticity of system reduces natural frequency and, on the contrary, with a decrease in the mass and an increase in the elasticity frequency grow/rises.

The three-dimensional/space propagation of acoustic waves in the atmosphere depends on the ratio of the size/dimensions of emitter to wavelength. The emission/radiation of material fluctuations by the source of small in comparison with the wavelength of size/dimension occurs in the form of spherical or spherical waves.

The oscillatory motions of the plate, stopped up into jaws and given into action by free play to one side, create the directed air waves, exiting/waste from its oscillating edge in the form of sector or hemispheres. The sound of large intensity with the shortest wavelength is headed by the narrow beam, called plane wave.

Acoustic wave is formed under conditions of the air medium with pressure in one atmosphere.

In all cases air wave consists of two periodic layers: the condensed under effect of pressure, caused by oscillatory motion, and rarefied.

The graphically oscillatory motion of air wave is depicted in the form of the sinusoid on which it is possible to determine the basic physical parameters of wave (Fig. 1).

The amplitude of oscillation is greatest of deviation from quiescent point. The amplitude of oscillation is measured in millimeters and indicates the greatest increase of air pressure Δp , of the emergent under action mechanical impulse.

Page 7.

Air pressure Δp is a difference between the actual pressure of acoustic wave p and the atmospheric pressure p_0 .

The unit of the measurement of sound pressure bar is equal approximately to one millionth of atmospheric pressure or pressures in 1 dynes on 1 cm² of surface.

Graphic sound pressure Δp is equal to amplitude a , and therefore it they frequently call the amplitude of sound pressure.

Wavelength λ - the distance between two symmetrically arranged/located points of the adjacent acoustic waves, which made one complete cycle.

Period T - time for which was made one complete cycle of oscillation/vibration.

Frequency of acoustic wave - a quantity of periods, which were repeated for one second.

Unit of the measurement of frequency - hertz (Hz). Hertz is equal to one oscillation/vibration per second.

The oscillations of the air wave, which are repeated per second are not less than 16 and not more than 20,000 times, they transfer the sound of the vibrating body, which recovers by the organ/control of the audition of man. This range of the oscillations of air wave he is called audio-frequency range, and air wave by acoustic wave.

A quantity of oscillations determines the tone of sound.

If the reverberating body accomplishes not more than 100 oscillations per second, sound is obtained low (anechoic). With an increase in the number of oscillations, the sound acquires higher (whistling) tone.

Intensity or sound intensity in the source of its formation/education depends on the mass of the reverberating body and spread/scope, which arose in it under the effect of shock or another stimulating effort/force.

Intensity - concept physical, that gives estimation of sound intensity according to energy content which will bear the air or acoustic wave.

As the unit of intensity, measurement is accepted quantity of the ergs of energy, elapsing 1 s through 1 cm² of the surface, perpendicular to the direction of sound. Intensity is measured in erg/cm²/s, dyn/cm² or in W/cm².

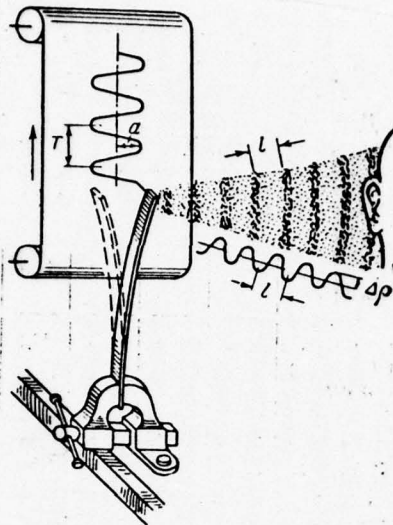

Fig. 1. formation of oscillatory motion and its parameters. a is amplitude of the oscillation of acoustic wave, Δp - the amplitude of sound pressure, T - the period of oscillation, l - wavelength.

Page 8.

Theoretically the motion of acoustic wave is infinite, but practical its energy is expend/consumed on the overcoming of the internal friction of particles and air resistance, to acoustic radiation it is converted into heat. With the removal/distance of acoustic wave from sound sources, increases its acoustic field, but

simultaneously decreases its energy.

The intensity of acoustic wave decreases inversely proportional to the square of distance from source, i.e., with an increase in the distance double, triple, four times sound intensity decreases respectively four, nine, sixteen times.

With very short waves sound, possessing the highest energy, it is spread by the almost nondivergent sonic ray/beam, retaining energy in the center of beam. For this reason high sounds are well audible only against emitter, on the side from emitter their audibility is insignificant.

The length of acoustic wave is a value that depends on frequency. Than is more frequency, those is shorter wavelength. With the smallest number of oscillations, the length of air wave has maximum value (Table 1).

Therefore high-frequencies sound they are called short-wave, and low-frequencies sound - long-wave.

Sound is spread through all bodies - solid, liquid or gaseous, but at different rate.

The velocity of propagation of acoustic wave or the vibrational speed of the particle motion of this medium is called the speed of sound v . It depends on the module/modulus of elasticity and density of medium c and does not depend on intensity or frequency sound source.

For each this medium (by gaseous, liquid or solid) under identical conditions the speed of sound is constant value. The velocity of propagation of acoustic wave in the different media with $t = 0^{\circ}\text{C}$ is represented in Table 2.

The vibrational speed of movement of the particles of air or another gaseous or liquid medium is measured in meters per second.

During a change in the atmospheric pressure, the speed of sound does not change, since simultaneously and proportionally is changed the density of the medium.

With an increase in the temperature, the speed of sound increases, since air density decreases and the speed of the motion of its particles grow/rises.

Table 1.

(1) Частота в гц	50	100	200	300	500	1000	2000	3000	5000	10 000
(2) Длина вол- ны ($t=20^{\circ}\text{C}$) в см	680	340	170	113	68	34	17	11,3	6,8	3,4

Key: (1). Frequency in Hz. (2). Wavelength ($t = 20^{\circ}\text{C}$) in cm.

Page 9.

The product of the density of medium c by the speed of propagation of sound v calls the specific acoustical resistance of the medium.

The unit of the measurement of the specific acoustical resistance of acoustic ohm is expressed in $\text{g/cm}^2/\text{s}$. In Table 3 shown acoustical resistance of the different media.

Specific acoustic resistance as index of density determines the sound-insulating properties of materials.

Noise and some of its laws.

Sound (or the sounds, formed by the periodic sinusoidal oscillations of the reverberating regular body, for example tuning fork) is received by eye/ear as idle time or the so-called musical sound, the tone.

Pitch of tone is determined by the frequency of sound.

Table 2.

(1) Среда	(2) Плотность ρ г/см ³	(3) Скорость распро- странения звука v м/сек
(4) Воздух	0,001205	332
(5) Пресная вода	1,0	1430
(6) Резина	0,92	54
(7) Войлок в несжатом виде	0,6	530
(8) Пробка	0,24	500
(9) Песок	1,6	2000
(10) Кирпич	1,8	3600
(11) Гранит	2,7	3900
(12) Свинец	11,3	1322
(13) Сталь	7,8	5000
(14) Стекло	3,0	5200

Key: (1). Medium. (2). Density ρ g/cm³. (3). Speed of propagation of sound v m/s. (4). Air. (5). Fresh water. (6). Rubber. (7). Felt in uncompressed form. (8). Plug. (9). Sand. (10). Brick. (11). Granite. (12). Lead. (13). Steel. (14). Glass.

Table 3.

(1) Среда	(2) Сопротивление в акустических омах	(3) Среда	(4) Сопротивление в акустических омах
(3) Воздух	43	(4) Пробка	120 000
(5) Водород	11	(6) Резина	5 000
(7) Вода	150 000	(8) Войлок в несжа- том виде	32 000
(9) Стекло	1 200 000	(10) Кирпич	647 000
(11) Сталь	3 900 000	(12) Песок	320 000

Key: (1). Medium. (2). Resistance in acoustic ohms. (3). Air. (4). Plug. (5). Hydrogen. (6). Rubber. (7). Water. (8). Felt in uncompressed form. (9). Glass. (10). Brick. (11). Steel. (12). Sand.

Page 10.

The which surround us reverberating real object/subjects accomplish complex oscillations. For example, in string or plate with shock, besides basic oscillation in the place of application of force on the adjacent and more removed sections also arise waves, but the more high frequency which are superimposed on basic oscillations, they interact with them.

The fundamental tone is always accompanied by a series of other

tones which are called overtones, i.e., by higher tones.

Pure/clean sound to obtain is very difficult.

If frequencies of overtones are multiple to fundamental frequency, then such overtones call musical or harmonic tones. They paint complex tone and they give to it the so-called "velvety" timbre.

during the complex oscillations of bodies, appear also many nonharmonic, not multiple to the fundamental tone, overtones. If they considerably differ in height/altitude from the fundamental tone, then sound acquires sharp "metallic" timbre.

The irregular combination of the complex tones, which simultaneously proceed from working instruments, the colliding metal, machine tools or mechanisms, he is called production noise.

In physical concept production noise is the complex tone, consisting of the large number of sounds of simple tones and overtones of different height/altitude, force and direction. Between their parameters - by frequency, by the amplitude of sound pressure, by intensity - there is no any communication/connection, but all the oscillations as a whole bear irregular and unstable character.

Contemporary production consists of a whole series of the complex processes, fulfilled with the aid of machine tools, machines and other mechanisms whose work is accompanied by the intense production noise.

For reasons for emergence, they distinguish:

a) the impact noise, which appears during the execution of impact technological processes (in forging, forging, the straightening of metallic sheets, tinsmithing works, riveting, the work of knockout machine tools, weaving and shoe machines, of tumbling barrels, etc.);

b) the mechanical noise, which appears as a result of friction of node/units and parts of mechanisms at idle and working course (in catching of toothed wheelss, in the work of cam/catch/jaws, valves, crank gears, etc.), and also with the malfunctions of mechanisms, as a result of eccentricity, internal slants, the inaccuracies of assembly or wear of parts (here enter cutting forces, torsional oscillations, the clank of metallic parts, materials and articles);

c) the aerodynamic or hydraulic noise, which appears at high

speeds of the flow of air or liquid, with abrupt changes in the direction (flow about the blade/vanes, on edges, with rotations or the overcoming of any obstructions), during pressure change (during compression, expansion, with explosive-formation/education, during a change in temperature, etc.).

Page 11.

Any noise or complex sound can be decomposed and presented graphically in the form of its component simple sounds with the indication of frequency and intensities of each of them.

The graphic representation of the composition of production noise he is called noise spectrum.

Noise spectrum makes it possible to judge the character of sound source and its frequency composition, to determine the most harmful sounds and their localization helps to solve the question concerning the measures of fight.

Any noise has its, characteristic for it spectrum. The noise spectrum of forging shop will differ from the noise of machine shop, and the noise of compressor differ from noise and smithy and machine shop.

The acoustic waves, which proceed from different sources, but unidirectional and which coincide in their phases, they are summarized; having accurately opposite direction, with identical intensity and the amplitude when the apex/vertex of sinusoid coincides with the deepening of another phase, they are liquidated; those who are converging at an angle or not cophasal affect each other, they store/added up partially, as algebraically, and "mask" common/general/total background noise. This phenomenon he is called interference (Fig. 2).

Common/general/total noise level for many sources only insignificantly differs from the highest its components, but sometimes it is less them precisely on the strength of the resultant action of interference.

With two the noise sources of the equal to intensity, common/general/total noise level increases (Table 4).

Total noise levels from identical sources at the equidistant from them point are given in Table 5.

With removal/distance from sources, the noise is

attenuate/weakened.

When, in the large location, several identical sources of noise are present, near each of them, predominates its inherent noise.

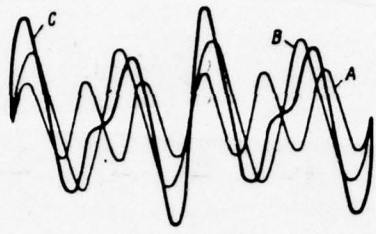

Fig. 2. Interference of sound (algebraic addition). A, B - curved of sound vibrations, C - the resulting curve.

Table 4.

(1) Разница в дБ	0	1	2,5	4	6	8	10	12	16	20
(2) Добавка к уровню одного источника в дБ	3	2,5	2,0	1,5	(3) Практически можно не принимать во внимание					(4) Звук маскируется

Key: (1). Difference in dB. (2). Addition to the level of one source in dB. (3). Virtually it is possible not to take into consideration. (4). Sound is masked.

Acoustic waves, as light, can be scattered in the environment.

The acoustic waves, which appear indoor, which has four walls, ceiling and sex/floor, achieving the enclosing construction, they can be reflected from its surface partially or completely (Fig. 3), to be refracted during transition of one medium to another, to be absorbed by the new medium or to penetrate through it, and also to affect the elastic system as mechanical impulse, to transfer by it its energy - to be for it perturbing force and to become the reason for the emergence of new mechanical or acoustic elastic waves (Fig. 4).

Encountering in way barrier/obstacle, acoustic wave is reflected at an angle, equal to the angle of its incidence/drop and which lies at one with it plane. Sonic ray/beams after the first reflection are distributed on entire location, then they are reflected again, they are accumulated in the point, symmetrical with respect to starting point, they are reflected again and so many times until sound consumes entire its energy and will not go out slowly after the multiple repetition of its way. The continuation of sounding after the cessation of sounding he is called reverberation.

Table 5.

(1) Число источников	1	2	3	4	5	6	8	10	20	30	40	100
(2) Добавка к уровню од- ного источника в дБ	0	3	5	6	7	8	9	10	13	15	16	20

Key: (1). Number of sources. (2). Addition to the level of one source in dB.

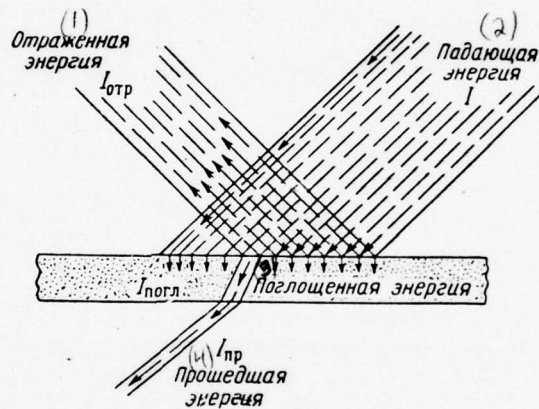

Fig. 3. Circuit of reflection, absorption and passages of the sound through the obstruction.

Key: (1). Reflected energy. (2). Incident energy. (3). Absorbed energy. (4). Come energy.

Page 13.

The greater the intensity and is above the frequency of acoustic wave, the greater time of its fading. Reflection coefficient characterizes the conservation of energy of sound. The duration of time during which (after the cessation of the sounding of source) the energy of sound descends to threshold of audibility, he is called reverberation time.

The lesser the size/dimensions of location, the greater number of reflections and, consequently, also absorptions occurs in time unit, the faster attenuates noise.

Maximum sound absorption occurs at the medium frequencies between 150 and 4800 Hz. With an increase in the frequency, the absorption increases absolutely, but it decreases relatively. The absorption coefficient characterizes the energy loss of sound.

The structure of the material of enclosure/protection is always capable of resisting energy of acoustic wave (large either numerous pores, cracks, slots, opening/apertures or the low acoustical resistance), and acoustic wave passes through it.

During transition of one medium to another (for example, from metal into air, from air into liquid) occurs refraction or the refraction of acoustic wave. In this case, the sines of the angles of incidence and refraction are related between themselves as speeds of sound in the appropriate media.

To the passage of the sound through any medium, just as on the reflection of sound, is spent the part of sound energy.

The coefficient of sound conduction indicates, what part of sound energy is transferred through enclosure/protection.

The sum of the coefficients of sound reflection, sound absorption and sound conduction is equal to unit.

If acoustic wave encounters in its way window, ventilation unit, opening/aperture, then, in passing by through it, it becomes source for the formation/education of the new sound wave. If obstruction (screen), net in the way of the propagation of acoustic wave, has small size/dimensions, then acoustic wave flows about the it. If obstruction large of size/dimensions, then is acoustic wave, flowing it, it can be divided into two hose/pipes which subsequently they can

merge, after leaving for screen the area of silence or sound shadow. The higher the intensity of acoustic wave or the lesser the obstruction, the shorter there will be the sound shadow. This phenomenon he is called diffraction.

Sound is spread not only in air. the more intense way of sound propagation is a transmission of the oscillations, caused by the vibration of the reverberating body, by percussion devices, by walking, transport, in the form of the material or solid sound, spread through partition/baffles and overlaps (Fig. 4), especially during incorrect arrangement/permutation of equipment (Fig. 5), and also the penetration of sounds into building from the side (Fig. 6). Such sound transmissions they occur the more completely than the tight connection of the parts of the construction and than nearer among themselves the value of the acoustical resistance of the conjugated/combined materials.

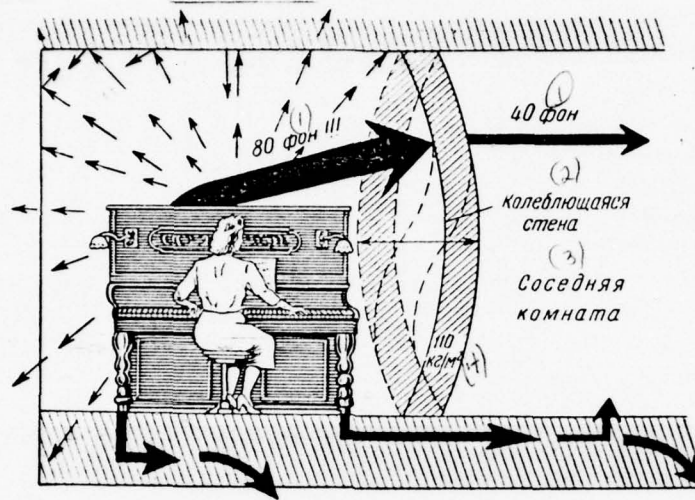

Fig. 4. Propagation and the penetration of sonic ray/beam and vibration through partition/baffles and overlaps.

Key: (1). background. (2). Oscillating wall. (3). Adjacent room. (4).

kg/m².

Page 14.

PHYSIOLOGICAL EFFECT OF INDUSTRIAL NOISE ON THE HUMAN ORGANISM.

The auditory function of organism is the function of complex. It consists of the basic organ/control of audition and which amplify sonic perception perceptions through bone and the skin integument of body.

In the structure of the basic organ/control of the perception of sound - eye/ear - are distinguished three principal parts:

a) extrinsic eye/ear (Fig. 7) consisting of the pinna and the external auditory passage, which is finished with the eardrum;

b) the middle ear (Fig. 8) with the grafted to the eardrum three nuclei, which transmit its oscillations to the inner ear, by hammer, by anvil and stirrup and with the short tube, called the eustachian

tube, which connects the internal cavity of the eardrum with upper part the swallows (closed in its lower part eustachian tube is opened slightly with ingestion, as a result of which entering into it in this case air equalizes air pressure within the middle ear with ambient pressure);

c) the inner ear or labyrinth, that consists of three semicircular canals and the snail/cochlea. Labyrinth is wholly filled by liquid/fluid (endolymph). Snail/cochlea is divided by "basic diaphragm/membrane" to two "floor".

Page 15.

Diaphragm/membrane consists of several thousands of nerve fibers of different length and thickness, collected in the form of the peculiar, gradually increased keyboard whose each key (receptor) is tuned to its peculiar singular to them received sound.

The eardrum, possessing elasticity, it acts as pressure unit of acoustic wave.

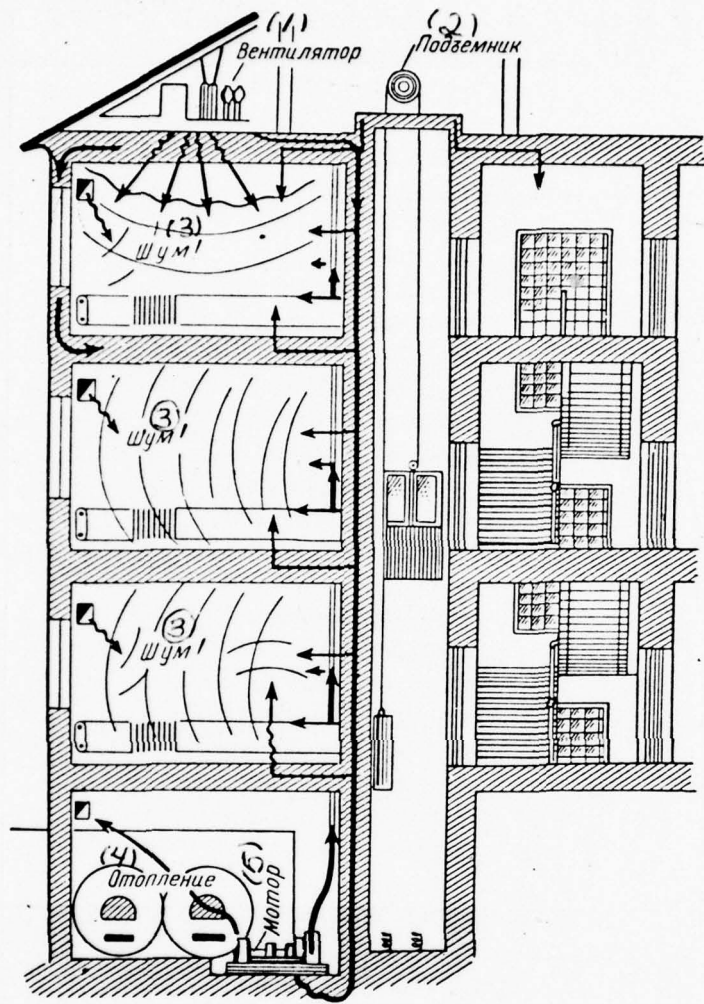

Fig. 5.

Fig. 5. Sound propagation on building during incorrect arrangement/permutation of equipment.

Key: (1). Fan. (2). Lift. (3). Noise. (4). heating. (5). Motor.

Page 16.

The acoustic waves, caught by extrinsic eye/ear, cause the oscillations of the eardrum and connected with it auditory nuclei, which lean on the most sensible diaphragm of oval fenestra in the inner ear, which lies on liquid/fluid of labyrinth. Under oval fenestra is located second circular fenestra also tightened by diaphragm. When the diaphragm of oval fenestra is drawn in, the diaphragm of circular fenestra is stuck out, allowing for liquid/fluid of labyrinth, by that not yielding to compression, to accomplish oscillations.

Auditory nuclei, transferring acoustic waves, they modify them: the amplitude of their oscillations is decreased, and force of pressure is increased, which contributes to reduction into the fluctuation of liquid/fluid of snail/cochlea. Frequency in this case remains invariable/unchanged.

Receptors, obtaining periodic momentum/impulse/pulses, they guide them on centripetal nerve fibers to the auditory center of the cortex of major cerebral hemispheres for response reaction (vocal, motor, etc.).

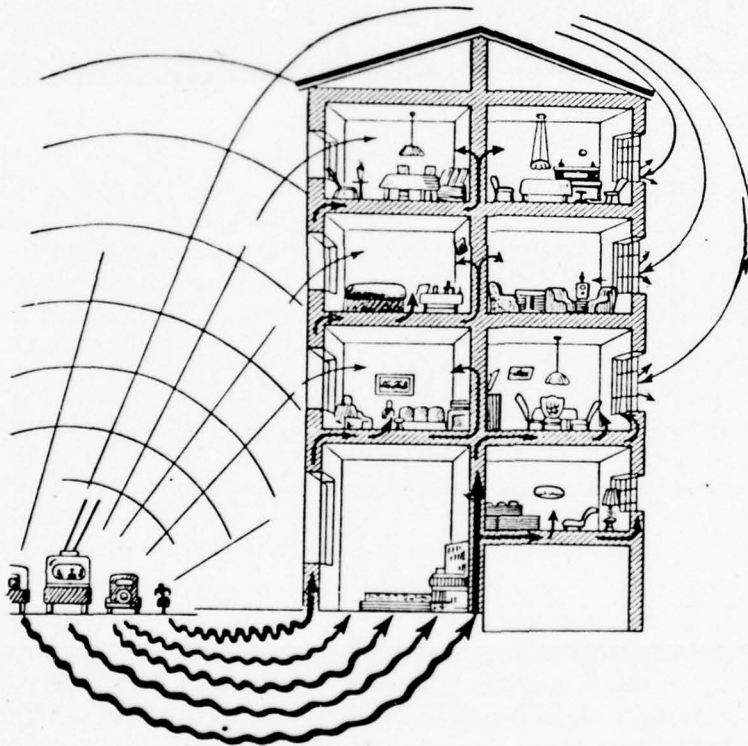

Fig. 6.

Fig. 6. Penetration of sounds into building from the side.

Page 17.

Acoustic wave (low frequency), besides extrinsic and middle ear, can penetrate the inner ear to the snail/cochlea through the temporal bone (bone conduction).

The auditory perception, obtained on the basis of cochlear reception, is amplified because of diffuse sonic reception (vibration-tactile perception), that is the property of all living cells, especially the cells of the surface integuments of organism, which possess this property, although by unevenly distributed in the different areas of skin integument.

Diffuse sonic receptor is the residual substance of the perception of the auditory perceptions of the primary living organism which, until now, has been preserved in man. From diffuse sonic reception the momentum/impulse/pulses go over the filaments of spinal cord to the visual mounds where they are contacted with cochlear ways and amplify sonic perception.

Cochlear sonic receptor is more advanced, it obtains auditory

perceptions by means of air and bone- cranial conductivity.

The range of sensitivity of hearing aid is extremely great. Eye/ear receives as sound of the oscillations whose frequencies cover area from 16 to 22000 Hz in children and to 16000-18000 Hz in adult people.

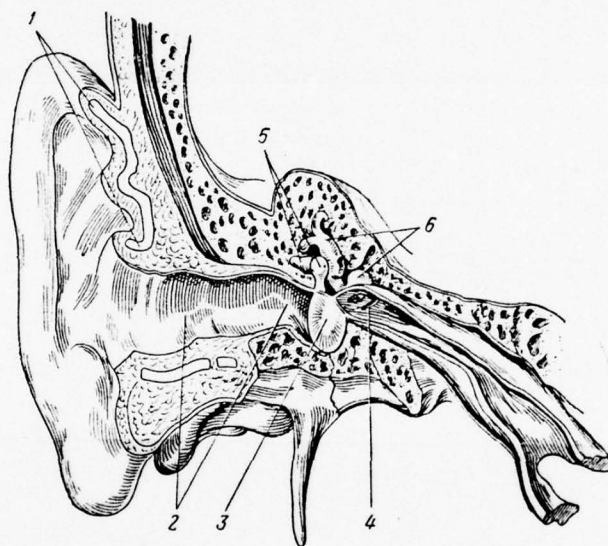

Fig. 7. Extrinsic eye/ear. 1 - gravel of the pinna, 2 - extrinsic auditory passage, 3 - the eardrum, 4 - eustachian tube, 5 - the inner

ear, 6 - the middle ear.

Page 18.

Frequency is received by man as pitch of tone. The greater the frequency, the higher the tone of audible sound.

Low bass sounds have frequencies from 30 to 300-400 Hz, average/mean - from 400 to 800-1000 Hz, high - above 1000 Hz.

The capability of eye/ear for a comparative evaluation of two simple sounds, not differing by height, is established/installed already from 0.30/o to 10/o (1000 osc./s it is possible to differ from 1003 osc./s or 100 osc./s from 101 osc./s for bass tones).

The components of industrial noise, which have the frequencies, which correspond to musical tones, are transferred by man considerably more easily.

Acoustic wave in order to affect the auditory organ/control, must possess the determined intensity. The range of intensity of acoustic wave, perceived by eye/ear, between its extreme values by height is distinguished approximately into a million of millions

once. This range he is called intensity level.

For a perception very low on frequency (to 64 Hz) and high (above 15000 Hz) sounds, i.e., extreme values on the threshold of audibility range, intensity must reach almost 90 dB. With removal/distance from the outer limits of audibility range, the sounds begin to be received at the lower value of intensity. Is most wide the auditory sensation area of sounds approximately 1000 Hz in frequency. At this frequency the sounds are audible at intensity from 0.1 to 10^{13} dB.

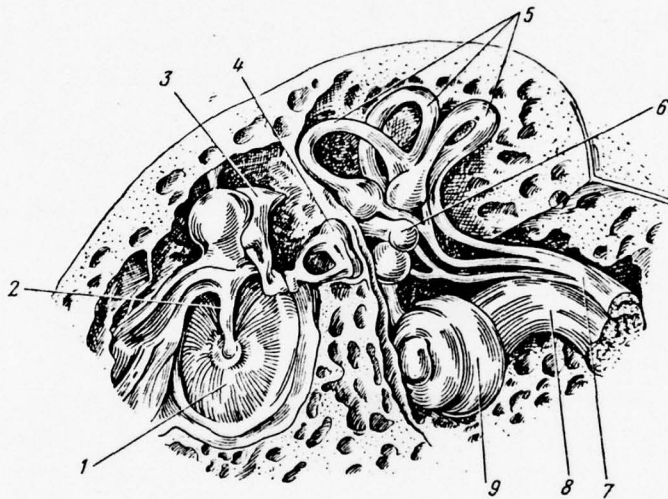

Fig. 8. More average/mean and inner ear. 1 - the eardrum, 2 - the grafted to it nuclei (melleus), 3 are an anvil, 4. striving, 5. semicircular canals, 6. otolith apparatus, 7 and 8 - the nerves, exiting/waste from semicircular canals and snail/cochlea to cerebral

cortex, 9 - snail/cochlea.

Page 19.

Minimum sound intensity, which in state to perceive eye/ear, is called threshold of audibility.

Threshold of audibility - phenomenon is subjective. It changes many times depending on the state of the auditory function, age and other factors.

Thus, for instance, threshold of audibility for a tone in 1000 Hz for a normal audition must have intensity, equal to 0.001 bar or 0.000001 atm., with light/lung deafness is necessary already strengthening sound intensity to 0.1 bar, which corresponds to an increase of sound pressure 100 times, but energy 10000 times, i.e., threshold of audibility in this case higher than normal.

Threshold of audibility is determined with the aid of standard. As standard is accepted the standard tone in 1000 Hz at the minimum value of intensity, which is compared with the zero level of comparison.

As the zero level of comparison, is conditionally accepted standard tone into 1000 Hz, equal in the units of sound energy 10^{-9} erg/cm²/s or 10^{-16} W/cm², and in unity of sound pressure 0.000204 g/s²/cm or $2 \cdot 10^{-4}$ bar.

The zero level of comparison lie/rests below the audibility range of man and is starting point from which subsequently are conducted all readings of acoustic values.

Standard sound is fed to auditory organ/control with a slow increase in the intensity until in man appears the first perception of audibility. Thus is establish/installated threshold of audibility.

The difference between the zero level of comparison and threshold of audibility is measured in decibels and indicates the degree of hearing loss. The lesser this value, the earlier will appear the perception of the audibility, the acute/sharper the audition.

The action of noise with an intensity of 130 dB for man completely sound/healthy, with normal audition coincides with pain threshold, a further increase in the intensity produces morbid perceptions and can cause the sonic injury: the break of the eardrum, the atrophy of audition, the state of depression, behind which hides

itself the action on central nervous system, effect on the involuntary musculature of body and the psychics of man.

In some people the full/total/complete absence of the perception of sounds, or the upper boundary of the region of audibility, lie/rests below pain threshold. This phenomenon is connected with the premature ossification of the eardrum. Especially frequently this phenomenon is observed in persons, long time of those who were worked under conditions of high-frequency noise.

^T
The sound intensity level in range of audibility between threshold of audibility and pain threshold it is possible to measure in W/cm^2 , in energy units - ergs (work, produced force into 1 dyne in way in 1 cm) or in the units of sound pressure in bars (pressure with force into 1 dyne on 1 cm^2 of surface).

Page 20.

The sound intensity level or intensity level changes in geometric progression and grow/rises by jumps from the zero level of comparison 10^{13} or 10,000,000,000,000 times.

^H
However, virtually manipulations with multiple-valued numerals are inconvenient and, furthermore, completely they do not correspond

to the physiological perception of sound vibrations, which would hinder/hamper judgment about physical phenomenon from physiological positions. This all the more correctly since the audition within audibility range catches an increase in the sound intensity, differing from the preceding/previous perception to 260/o.

The identical growth of volume is noted by the organ/control of audition only in such a case, when sound intensity changes into the identical number once, and not to some number of ones.

For this reason for the measurement of the sound intensity or its intensity level, is introduced the logarithmic scale, in which each step/stage differs from preceding/previous and that which follows 10 times. This relationship/ratio is named bel. Bel indicates that in how often the unknown sound intensity I exceeds initial value I_0 . But since $\log_{10} 10^1 = 1$, $\log_{10} 100 (10^2) = 2$ $\log_{10} 1,000,000 (10^6) = 6$, this indicates that the first sound exceeds another by 1; 2 or 6 bel. Therefore the graphic scale of decibels has equal intervals and indicates that in how often, the measured value of intensity is greater than the zero level of comparison.

In practice for the measurement of sound intensity, are accepted smaller unit, decibel, equal to 0.1 bels.

The calculation of intensity level is conducted by the formulas

$$\beta = \lg \frac{I}{I_0} \text{ bel or } \beta = 10 \lg I/I_0 \text{ dB,}$$

where I is a sound intensity;

I_0 - a zero level of comparison.

The product of intensity or sound intensity by the number of oscillations per second creates volume of sound. Volume - concept physical ¹.

FOOTNOTE ¹. The unit of the measurement of volume gro is conditional. For initial value for it, is accepted the loudness level of sound 40 background, which approximately corresponds to the volume of whisper at a distance 0.3 m. 1 gro corresponds to the introduced outside boundary unit of the measurement of volume, i.e., sleep. ENDFOOTNOTE.

The perception of volume the organ/control of the audition of man is characterized by from this concept, since to each frequency corresponds its amplitude of sound pressure. The amplitude of sound pressure varies from 1 millionth of millimeter to 2 cm, and the

absolute value of sound pressure from 10^{-10} to 10^{-3} dyn/cm² or from $2 \cdot 10^{-6}$ to 3000 bar. The eardrum and those who were grafted to it of from within the nucleus middle ear under the influence on them of acoustic wave are converted it, decreasing the wave amplitude and increasing pressure. Low-pitched sound influence the perception of high-pitched sound. Therefore under the simultaneous influence on the eye/ear of several simple tones of different frequency and equal to intensity audible sounds do not present the sum of the volumes of these sounds, but is created qualitatively the new value, which has purely physiological value - loudness level.

Page 21.

Loudness level is the resulting quantity of the physiological perception of the sounds of different volume.

The comparison of the loudness level of sound with the standard sounds with a frequency of 1000 Hz makes it possible to reveal/detect/expose equally loud sounds which can be depicted graphically. ^Tthe physiological equality of the perception of the volume of different sounds is establish/installed only for audition.

For level measurement of volume is establish/installed physiological unit background, the corresponding to the uniform

growth of volume and indicating, how much measured volume is greater than the zero level of comparison. Volume grow/rises in the arithmetical progression.

The loudness level of the sound above threshold of audibility to pain threshold subjectively grow/rises 130 times.

The loudness level of the simple tone can be defined and as intensity, expressed in dB above threshold of audibility for a given frequency.

The dependence between volume and intensity in different areas is expressed both the e: 1 (Table 6).

The range of intensity, received by the organ/control of the audition of man, are placed into 13 bels or 130 dB.

On the given diagram (Fig. 9) are plotted/applied the physical and physiological quantities of sound or noise and equal loudness contour, arrange/located within auditory sensation area.

In the different questions of applied acoustics there is practical interest in a comparatively narrow frequency band: in speech we are encountered the sounds from 50-5000 Hz, where

60% of energy of human voice falls on area below 500 Hz, and about 85% of energy - to area to 1000 Hz.

Table 6.

(1) Сила звука		(4) Отношение интенсивностей	(1) Сила звука		(4) Отношение интенсивностей
(2) бел	10 lg ₁₀ (3) дцб		(2) бел	10 lg ₁₀ (3) дцб	
0	(5) 0 (порог слышимости)	1	7	70	10 ⁷
			8	80	10 ⁸
1	10	10 ¹	9	90	10 ⁹
2	20	10 ²	10	100	10 ¹⁰
3	30	10 ³	11	110	10 ¹¹
4	40	10 ⁴	12	120	10 ¹²
5	50	10 ⁵	13	130	10 ¹³
6	60	10 ⁶			

Key: (1). sound intensity. (2). bel. (3). dB. (4). Ratio of intensities. (5). threshold of audibility.

Page 22.

In the range from 1000 to 4000 Hz, the eye/ear functions in the best way. ^M Maximum sensitivity is arrange/located near 1000 Hz. Downward

from 800 Hz and upward from 6000 Hz the sensitivity of audition weakens, gradually disappearing with the approach to the boundary of audibility range.

On threshold of audibility, the eye/ear capably of catching the light/lung rustle of leaves, the flight of dixa midge, the beating of pulse, i.e., the volume, approximately equal to one millionth of atmospheric pressure, and the same eye/ear receives the noise of working motor approximately into 5000 bars or the sound artillery shot into 5 million bar.

Frequency variations with a of are less than 20 Hz, which lie/rests below the boundary of audibility (subsonic oscillations) or higher than the boundary of audibility (ultrasonic vibrations), they emit sound which objectively exist, but by the organ/control of the audition of man they are no longer received. the auditory organ/control of man does not hear the sound of Galton's whistle, which has 35,000 osc./s, whereas the eye/ear of dog, which has wider audibility range both in the area of low and in the range high frequencies, it receives. In many insect and animals, the audibility range is wider than in man, since for them the perception of infrasounds or ultrasounds has biological value and it is prepared by the centuries-old evolution of their organ/control of audition.

Direct effect on the organ/control of the audition of man, both infrasounds and the ultrasounds, it is detrimental.

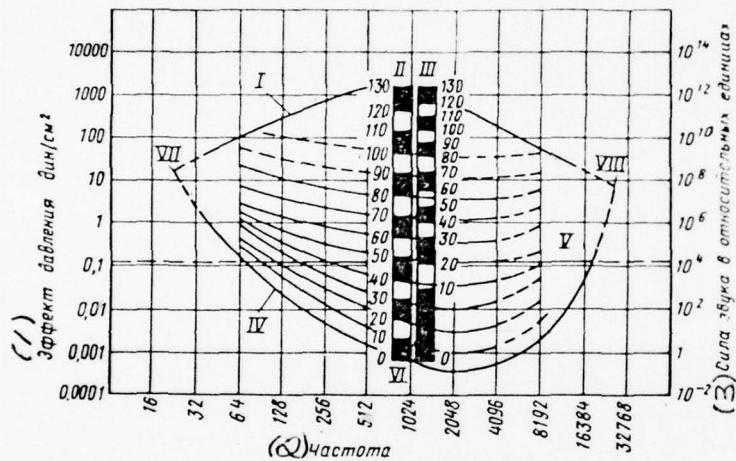

Fig. 9. Audibility range. I - pain threshold, II - the scale of decibels, III - the scale of volumes, IV - threshold of audibility, V - equal loudness contour, VI - the zero level of comparison, VII - lower boundary of audibility, VIII - upper boundary of audibility.

Key: (1). Effect of pressure dyne/cm². (2). Frequency. (3). sound intensity in relative units.

Page 23.

According to the data of the French scientists, working in the domain of definition of the degree of the physiological effect of noise on the organism of man ("Medecine aeronautique", 1955, No 4, pg. 309-356), the noise of approximately 150 dB for man is not borne. An increase in the intensity of the acoustic wave, directed toward metallic plate, to 180 dB, causes fatigue of metals. The ramjet/direct-flow air intensity waves with an of 190 dB cause the static damages: warping sutures, the escape of rivets, the destruction of metallic plate.

Thus, eye/ear plays the role of delicate apparatus, accurately reacting to negligibly small changes in the parameters of acoustic wave and which realizes a direct coupling of the human organism with the external world. At the basis of the work of hearing aid, lie/rest the laws of acoustics.

Is given below the table of the loudness levels, which are encountered in the daily life which can serve for the approximate determination of the loudness level of other noise sources as method of comparison (Table 7).

The degree of the stimulating noise effect depends on many reasons: the intensity of acoustic wave, frequency of oscillations, duration and regularity of its action.

Table 7.

(1) Источник шума	(2) Уровень громкости, дБ
(3) Шелот (тихий)	10
(4) Шелот средней громкости	20
(5) Биение сердца (у грудной клетки)	15
(6) В квартире с толстыми стенами ночью	15—20
(7) Тикание настольных часов на расстоянии 0,5 м	30
(8) В квартире днем (проникновение внешнего шума)	32—50
(9) Радио (тихая передача)	40
(10) Обычный разговор	60—65
(11) Шум учреждения	65—70
(12) Громкий разговор	70—75
(13) Пишущая машинка без подкладки	70
(14) Пишущая машинка с подкладкой войлока	60—62
(15) Радио (громкая передача)	80
(16) Шумовой фон в городе ночью	38—40
(17) Оживленная улица с трамваем	80—90
(18) В вагоне метро	80—90
(19) На платформе метро при проходе поезда	97
(20) Мотоцикл без глушителя	102
(21) Шум самолета в 5 м от винта	130

Key: (1). Noise source. (2). Loudness level, dB. (3). Whisper (calm). (4). Whisper of average/mean volume. (5). Beating of heart (of chest). (6). In apartment with thick walls at night. (7). Tick of clocks at a distance 0.5 m. (8). In apartment daytime (penetration of ambient noise). (9). Radios (calm transmission). (10). Usual conversation. (11). Noise of institution. (12). Loud conversation. (13). Typewriter without block/backing. (14). Typewriter with the block/backing of felt. (15). Radios (loud transmission). (16). Noise background in city at night. (17). Lively street with streetcar. (18). In the car of the metro. (19). On the platform of the metro with the passage of train. (20). Motorcycle without silencer. (21). Noise of aircraft 5 m of screw/propeller.

Page 24.

The question concerning which of the indicated reasons is most harmful,, until now, is not explained. It is known that the industrial noise acts on central nervous system and, consequently, also not entire human organism. As a result of its action, changes blood pressure, are disturbed the functions of heart, digestive organ/controls, appears nausea, vertigo and the whole series of other phenomena in organism, the speakers about the damage of normal state and calling supplementary energy consumption not for development and

vital activity of organism, but for the overcoming of the harmful effect of noise, on the self-defense of organism.

The high-frequency noises, i.e., such in composition of which predominate the sounds of high frequency more harmful, rather than low-frequency noises. Noise with an intensity of 120-130 dB causes a loss of efficiency of work on 40-60%, it retards the reaction of man to sound signals, attenuate/weakens attention, it contributes to an increase in the traumatism and occupational diseases.

Experiment shows that the tired eye/ear completely of sharpness perception does not reduce. Each time remains the minimum dose of "residual strain", sharpness decreases hardly by noticeable doses, and the time, necessary for the reduction of the normal functions of auditory organ/control, once from time grow/rises.

The prolonged action of high noise on the organ/controls of man is led to their regeneration, the appearance of a defective hearing, which converts to deafness.

The adverse effect of noise affects the workers already the first year of work and begins from the blunting of the audibility of various frequencies (most frequently in the range of the perception of frequencies from 2048 to 4096 Hz) in the basic curl of

snail/cochlea, and then it is spread to upper curl - the place of the application/appenrix of the effect of the waves, which go across the bone and the body.

A reduction in the normal threshold of audibility to 4 years comprises, i.e., 35 dB, to 6 years - 50 dB and to 8 years - 82 dB.

From the viewpoint of physiological, it is distinguished:

a) the local action of acoustic wave on the organ/control of the audition of man, including on his vestibular part;

b) the effect common/general/total - on central nervous system, and through it and on the more distant from eye/ear organ/controls.

Acoustic wave can apply injury to auditory organ/control both during air and during the bone passage of sound for snail/cochlea.

Injury can be acute/sharp, when damage in eye/ear occurs into very short intervals of time, very frequently for fractions of a second, as they speak "with lightning speed", and also chronic under the prolonged action of the industrial noise when damage is done gradually and is detected after the irreversible regeneration of the organ/control of audition and disorder of other functions of organism.

Page 25.

Acute/sharp injuries occur under the effect of the powerful aperiodic oscillations of the air medium, which traumatize the eardrum and the middle ear, or the periodic oscillations, which possess large intensity and which act on hearing aid for all its extent/elongation, i.e., without depending on the selective sensitivity of snail/cochlea to different frequencies.

The limit after which the sound or noise has their invariable/unchanged adverse effect on the human organism with the phenomena of residual action, includes the ability of the organ/control of audition for adaptation, i.e., for the perception of the sounds, which exceed harmless. But it is necessary to keep in mind that this ability of the organ/control of audition is very limited and does not exceed 10 dB. Furthermore, it is necessary to assume that the adaptation more concerns the conversion of sound pressure, i.e., the volume of auditory perception, since hearing aid to this conversion is adapted by nature.

The state of the audition of man is determined with the aid of the electro-acoustic instrument of audiometer (Fig. 10). Instrument

consists of the generator, which gives sinusoidal stress, regulable with respect to frequency, attenuator (divider/denominator), the exit voltage, calibrated completely in dB, and telephone or dynamics, calibrated completely by the special instrument, called "artificial eye/ear".

To the eye/ear of that investigated through the telephone, feed the sounds of different intensity, gradually it increasing, and, after grasping the onset of audibility, they note readings. Then they transfer/convert to the measurement of sensitivity in the range of other frequencies according to the established/installed scale.

The obtained results of measurements depict on audiogram and on a difference in the values establish the degree of deviation of audition from norm.

^F
for obtaining the data on the state of audition with high accuracy (to 2-3 dB) in the laboratory of LIOT is applied following method.

Investigation is conducted in the special sound and vibration-insulated room. ^I
instruments and investigator are arrange/located in adjacent room. Communication/connection with tested is maintained by indicating lights. Sounding can be

momentum/impulse/pulses on increasing or that which damps. The compound of these conditions with vocal reinforcement (according to the method of Prof. A. G. Ivanov- Ivanova-Smole's physiologo) makes it possible to obtain a precise representation of the state of audition.

The obtained results are checked by the perception of the intelligibility of speech.

The analysis of the state of audition with the aid of tuning fork, pocket watches, speech less it is in a whisper accurately, since it depends on many conditions which can lead to errors. ^Aare applied they only when instruments and experimenter's is absent, large experience.

The most accurate result can be obtained under laboratory conditions or the special chambers after the repeated removal/taking of readings. In such cases the audiogram is constructed according to average data.

The quantitative estimation of hearing loss is determined in decibels.

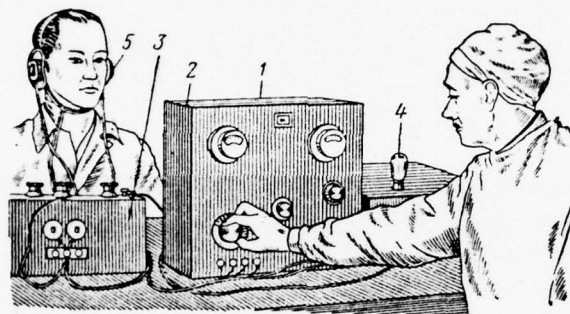

Fig. 10. Audiometry. 1 - audiometer, 2 - buzzer interrupter, 3 - rheostat, 4 - neon tube/lamp, 5 - telephone.

Page 26.

PRODUCTION CONDITIONS.

Noise level in production changes between separate shops between very wide limits depending on the character of installed equipment, its power, technology, time of connection/inclusion and disconnection of aggregate/units; an increase in the velocity even of one of the aggregate/units or a change in loading shop each time are led to a change in the composition of noise.

Furthermore, one should remember that and within the shop of noise at different points it can be different, since each source forms its noise zone (Fig. 11 and 12). Measures for a reduction in the noise are oriented precisely to isolated points.

The estimation of production conditions of work from the viewpoint safety and of industrial sanitation technique is produced

on obtaining of the following data:

a) the determination of the intensity level of noise (in dB) in shop and of separate aggregate/units;

b) the determination of the loudness level of the noise (in fon);

c) of the composition of the noise spectrum and development/detection of its harmful components;

d) the establishment of localization of the components of noise from sources.

The graphic representation of the intensity level of the components of production noise is different: the spectrum can be continuous, when in production noise enter components different closely spaced and to the frequency, and discrete (intermittent), that release from the overall zone of the noise of the intensity of tone components.

On one graph it is possible to compare several spectra. Along the axis of abscissas, divided to octaves or band, are set aside the frequencies of the simple tones, while along the axis of ordinates -

their amplitudes in relative values of noise intensity, directly counted off according to the scale of the output meter of the filter or in the absolute values of noise levels with respect to the geometric mean frequencies of the bands of analyzer or filter.

Page 27.

The determination of noise spectrum somewhat is complicated in the presence of periodic momentum/impulse/pulses, and also low-frequency components (vibration), not recording by sonic microphones, but having very large value during the determination of noise source.

This noise can be reveal/detected only by capacitor microphone with oscillograph.

Research on the spectra makes it possible to separate/liberate its basic components from the secondary, to determine most harmful and thereby to reveal/detect the reasons for their emergence, and consequently, the way of a reduction in noise and even structural/design estimation of mechanism.

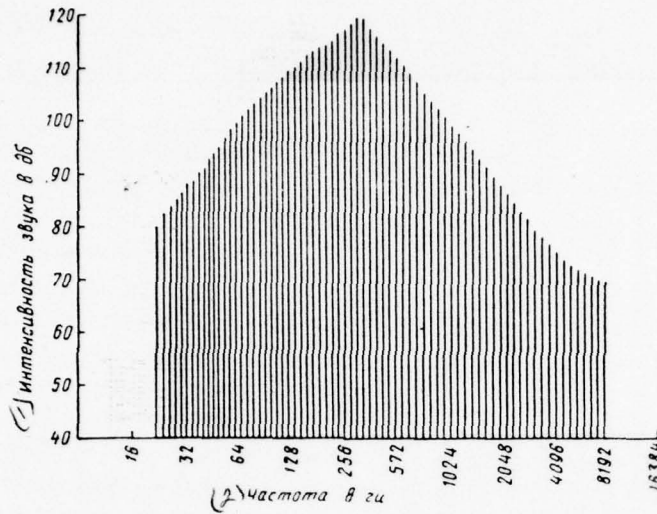

Fig. 11. Noise zone of tumbling barrel with electric motor.

Key: (1). Sound intensity in dB. (2). Frequency in Hz.

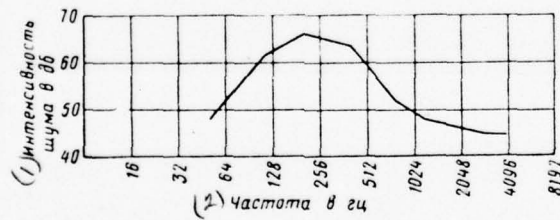

Fig. 12. Noise spectrum gasoline-engine saw.

Key: (1). Noise intensity in dB. (2). Frequency in Hz.

Page 28.

Table 8 gives the exemplary/approximate level of production noise, measured in shops with the predominance of the noise of impact character.

The noise spectrum of impact character (Fig. 13) is moved to the left, to the side of low frequencies (from 1 to 2400 Hz). This is the noise of large intensity and high loudness level.

The sounds of the low-frequency spectrum create the perception of touch and pressure not only in eye/ear, but are felt also with skin can lead in the forward direction of acoustic wave to the lightning breakage of the eardrum - to hearing loss.

The production noise spectrum of machine shops (Fig. 14 and Table 9) is distributed over a wide range of frequencies (from 20 to 8192 Hz). The large part of the components is arranged/located to the right in the range of average and high frequencies (from 200 to 5000 Hz). In the spectrum is noted the noise of all parts of the mechanism.

Negligibly small deviations in the size/dimensions of the parts of machine tool or aggregate/unit are reflected in the composition of noise.

Table 8.

① Наименование цеха или производства	② Интенсивность шума дб	③ Наименование цеха или производства	④ Интенсивность шума дб
⑤ Кузнечный	98	④ Обрубочное отделение литейного цеха	99—115
⑤ Удар молота по стальной плите	113—114	⑥ Очистные барабаны литейного цеха	108—113
⑦ Штамповочный	112	⑨ Пилонасекательные станки	110—115
⑧ Гвоздильный	98	⑪ Выколотка	98
⑩ Клепальный	117	⑬ Медницкий цех	102
⑫ Котельный	99	⑭ Галтовочный барабан	120

Key: (1). Designation of shop or production. (2). Intensity of noise dB. (3). Forging. (4). Chopping department/separation of foundry shop. (5). Blow of hammer on steel plate/slab. (6). The tumbling barrels of foundry shop. (7). Stamping. (8). Nailmaking. (9). file cutters. (10). Riveting. (11). Knockout. (12). Boiler room. (13). copper smithy shop. (14). The tumbling barrel.

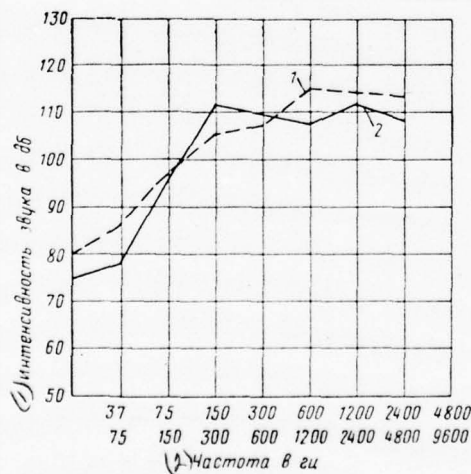

Fig. 13.

Fig. 13. Noise spectrum of impact character. 1 - the assembly of metal structures (stump of the welded joint by pneumatic chisel, 2 - stamping room.

Key: (1) - Sound intensity in dB. (2) - Frequency in Hz.

Page 29.

For different flaw/defects during the manufacture of mechanisms, is characteristic the determined noise: with the inaccurately carried out space of linking of gears, is noted the humming of variable force, with the incorrect geometric form of profile of the tooth of gears, is heard out the knock, which fluctuates noise it is the consequence of eccentricity of gears, etc.

Loudness level is masked because of low-pitched sound. In spite of the presence of high-frequency components the common/general/total noise level in machine shops is 85-90 dB.

The intensity level of aerodynamic noise is given in Table 10.

In the composition of aerodynamic noise spectrum, enter the noises of wide frequency band with the isolation/liberation of the

separate sharp components of the large intensity and unpleasant tone, which frequently reach pain threshold (Fig. 15 and 16).

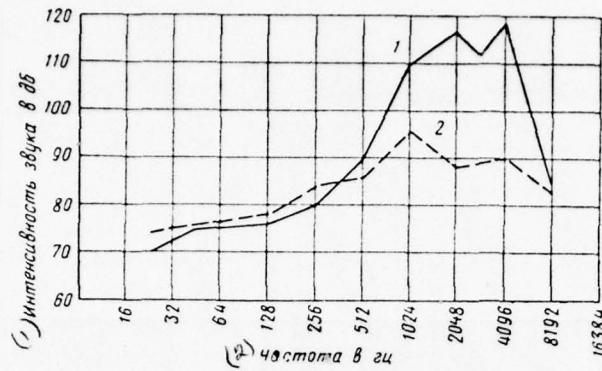

Fig. 14. Noise spectrum of machine shop. 1 - drilling, stripping, polishing, 2 - turning.

Key: (1). Sound intensity in dB. (2). Frequency in Hz.

Table 9.

Станок	Интенсивность шума дб	Станок	Интенсивность шума дб
Обдирочный	95—105	Шлифовальный	105
Токарный	93—96	Оплеточный	106
Сверлильный (Пневматик*)	114	Подiroвальные бара- баны	108
Строгальный	97		

Key: (1). Machine tool. (2). Intensity of noise dB. (3). Stripping. (4). Polishing. (5). Turning. (6). Braiding. (7). Boring (" pneumatic tire"). (8). Burnishing barrels. (9). Planing.

DOC = 7723¹⁶403

PAGE ~~34~~ 70

Page 30.

In certain cases noise source can become the resonance -
phenomenon of a marked increase in the amplitude of the oscillation
of the body, caused by the effect of external forces during the phase
coincidence of its own and external acoustic wave.

Table 10.

(1) Наименование цеха или производства	(2) Уровень интенсивности шума дБ
(3) Турбокомпрессорные залы	118
(4) Вентиляторы центробежные	105
(5) Компрессорная станция	110
(6) Пневматическая развальцовка	106—110
(7) Котельная (форсунка)	100

Key: (1). Designation of shop or production. (2). Intensity level of noise dB. (3). Turbocompressor halls. (4). Fans are centrifugal. (5). Compressor station. (6). Pneumatic rolling-out. (7). Boiler room (injector).

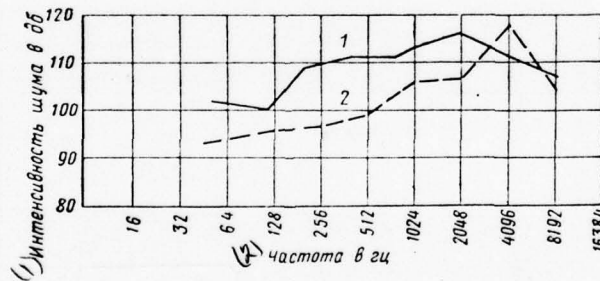

Fig. 15. Aerodynamic noise spectrum. 1 - welding set; 2 - bench of the blasting of the blades by airstream with a velocity of of 140

m/s.

Key: (1). Noise intensity in dB. (2). Frequency in Hz.

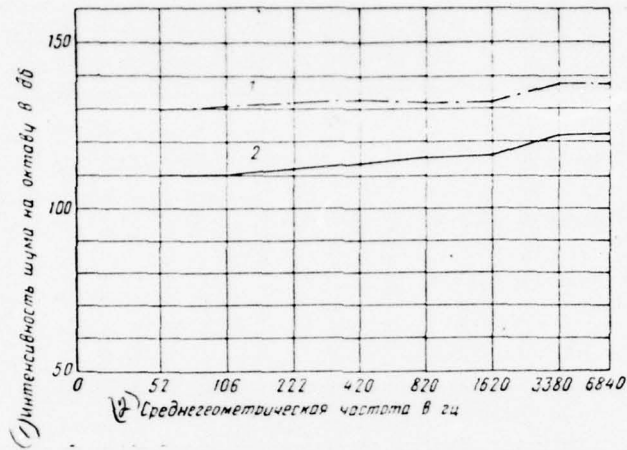

Fig. 16. Noise spectrum of centrifugal compressor. 1 - the cabin/compartment of testing, 2 - exhaust.

Key: (1). Noise intensity to octaves in dB. (2). Geometric mean frequency in Hz.

Page 31.

INSTRUMENTS PROCEDURE OF THE MEASUREMENT OF PRODUCTION NOISE.

For the measurement of the quantitative value of the intensity level or loudness level of production noise in shop or on work area, and also the noise, created by separate aggregate/unit or another primary source, to evaluate the effectiveness of measures or determination of the conformity of actual loudness level permissible is applied movable objective inspector audio-noise meter ShI-53.

The audio-noise meter ShI-53, designed in the Leningrad institute of the protection of labor (designer eng. Yu. M. Il'yashuk), makes it possible to measure the loudness levels from 55 background and are above, the intensity level of noise from 55 to 140 dB and noise level from 3-2500 gro.

The appearance of audio-noise meter with the removed cap/cover is given in Fig. 17.

Microphone 1 is built in into front panel 2, on which are arrange/located the needle indicator of output/yield 3; the knob/button of the connection/inclusion of feeding; the knob/stick of 4 switches, which realize/accomplishes shift of the frequency characteristics of audio-noise meter - switching the level through 20 dB and checking of the anode and filament voltage of lamps. On panel

is located the seat/socket for calibrating the strengthening from the grid/network of alternating current and the chrome-plated screw/propellers, which cover access to the splines of the control of filament voltage.

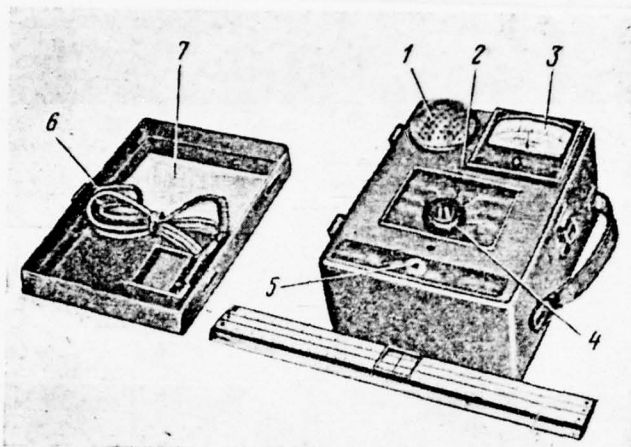

Fig- 17. Movable objective noise-survey meter SHI-53. 1 - microphone, 2 - front panel, 3 - the needle indicator of output/yield, 4 - the selector knob of the frequency characteristics of audio-noise meter (switching the level through 20 dB), 5 - the seat/socket of calibration, 6 - gauging cord, 7 - conversion table from loudness level to the scale of natural volume.

Page 32.

In the removable cover of cover, in special seat/sockets, are packed the screwdriver and gauging cord 6 with plug and the branching/fork in which is built in the divider/denominator. In cap/cover is fastened table 7 for transition from loudness level to

the scale of natural volume.

The principle of the work of audio-noise meter, in general terms, consists of following (Fig. 18).

Microphone converts sound vibrations into voltage. This voltage enters the entrance of special amplifier. Amplifier consists of 4 cascade/stages on lamps 1B1P and 2P1P (miniature finger pentodes) with feeding from two small dry cells (battery from hearing aids). It has two frequency characteristics: plane, or linear, for the measurement of sound intensity in all operating range of levels and for level measurement of volume from 80 background is above and the second, that corresponds to the sensitivity of human eye/ear on loudness level 70 background.

Standard microphone of the type of MD-35 is built in into front panel.

The needle indicator has a scale, calibrated completely within limits 25 dB (from -5 to +20 dB). On section from 0 to +20 dB, the scale is uniform. A change in the sensitivity is produced by the jumps through 20 dB. Reading of audio-noise meter is determined by the addition of readings of switch and the rifleman/gunners of indicator (if rifleman/gunner it is arrange/located more to the right

zero) or by the subtraction of readings of arrow/pointer from readings of switch (if rifleman/gunner does not reach to scale zeros)..

The translation/conversion of loudness level into the scale of natural volume is produced on the table, strengthened to cap/cover.

Audio-noise meter is calibrated from the grid/network of alternating current, it is simple in control, has weight 3.2 kg and small dimensions (200 x 160 x 110). It is regulated by the simple switching of characteristic.

Audio-noise meter determines the sound pressure level at the particular point. Several measurements of noise at different points is determined the average value of the common/general/total sound energy of noise source. Along with the inspection of source and its subjective audition, the sum of these data is sufficient for the overall estimation of noise and determination of the ways of its weakening.

For the establishment of the qualitative-quantitative estimation of frequency components in the composition of noise to objective audio-noise meter, are connected the instruments for automatic analysis - analyzers or octave band-passs filter.

For relieving the noise spectrum under production conditions, is applied the portable band frequency analyzer of LIOT of the construction of eng. Yu. M. Il'yashuk (Fig. 19), in whom are used the so-called active or electronic filters RC. Analyzer requires the amplifier as which is utilized the audio-noise meter ShI-53. The frequency characteristics of analyzer are analogous to the characteristics of spectrometer.

Page 33.

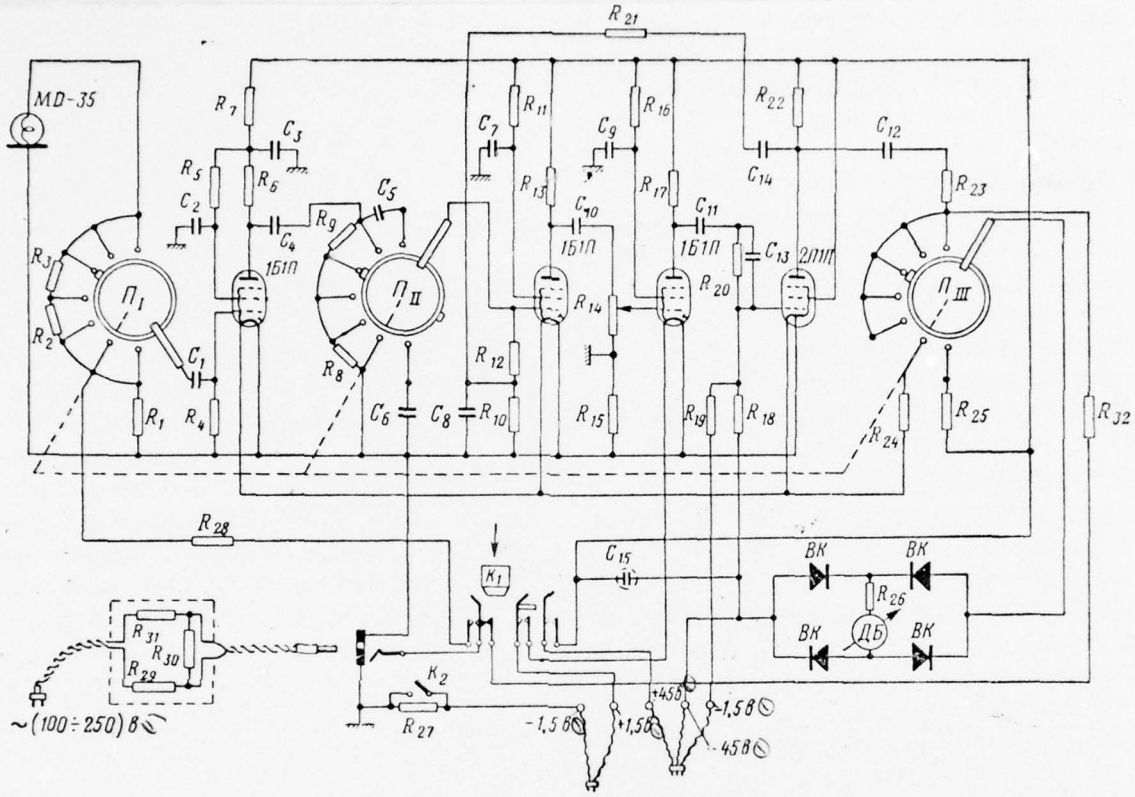

Fig. 18. Circuit of audio-noise meter of ShI-53.

Key: (1) . V.

Page 34.

Working frequency band of the instrument from 36 to 10,000 Hz.

Instrument has 25 adjacent bands with a width of into one third of octave.

Instrument consists of two mutually detuned frequency-selective amplifiers and the output stage with the indicator whose scale is thoroughly calibrated within limits 30 dB. The exchange of passbands is realize/accomplished by switching condenser/capacitors and resistances in block RC.

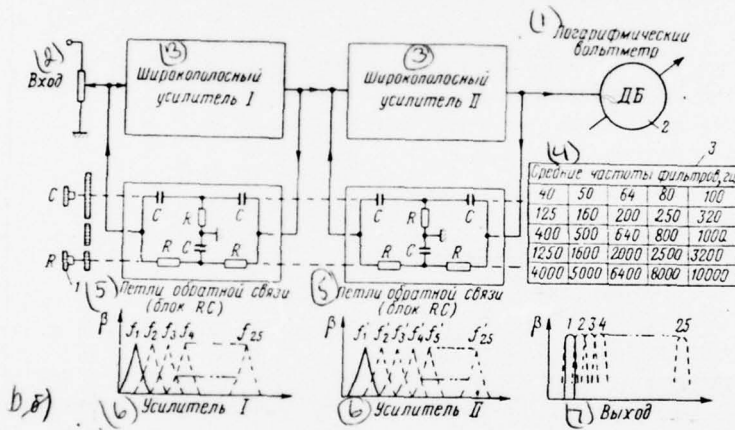
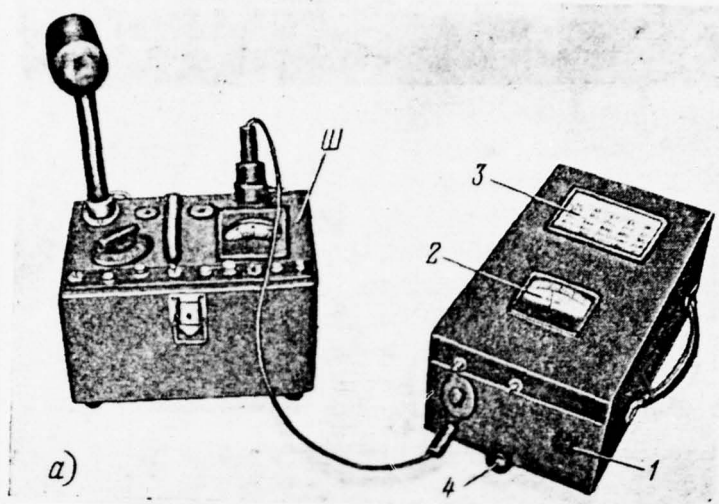

Fig. 19. Frequency analyzer of LIOT. a) are general view, b) - block diagram. 1 - the paired switch, 2 - output meter with the scale on 30 dB, 3 - frequency scale, 4 - the knob/stick of the start of instrument and the check of the supplies of power, Sh - audio-noise

meter.

Key: (1). Logarithmic voltmeter. (2). Entrance. (3). Wideband amplifier. (4). The medium frequencies of filters, Hz. (5). Loops of feedback (block RC). (6). Amplifier. (7). Output/yield.

Page 35.

In work rotates one selector knob alone of bands and each time they are record/written reading output meter.

For the acceleration of the process of the analysis of noise, the recording of readings of audio-noise meter can be produced by an instrument-automatic recorder of Neumann and then be transferred to graph. Thus are determined the relative noise levels in each of the bands. The obtained values are related to the geometric mean frequencies of passbands, given in Table 11.

With absence of portable instruments for the measurement of characteristics and analysis of noises during the different mode/conditions of the work of aggregate/units, it is possible to become district sanitary-epidemiological station or to write noise with the aid of portable magnetic recorder with the subsequent

treatment of the recordings under laboratory conditions. Is especially convenient this method during the study of rapidly changing and short-term noises.

Entire/all metering equipment (audio-noise meters, analyzers, etc.) must periodically, is not thinner than one times per annum, to be checked and to be calibrated in special acoustic laboratories and to tested.

The measurement of noise must be produced on work areas.

In shops with the even distribution of noisy equipment common/general/total noise level is measured at two points according to the longitudinal axis of location at a distance of one third from transverse walls and height/altitude 1.5 m of sex/floor.

In shops with the concentrated arrangement/permutation of noisy mechanisms - at a distance 1 m of mechanism from noise source and height/altitude 1.5 m of sex/floor. In the cabin/compartments of observation and in the locations, which do not have noisy equipment, in the middle of location, at height/altitude 1.5 m of sex/floor.

Table //.

1) Пределы частот октавной полосы гц	2) Средние геометрические частоты гц	1) Пределы частот октавной полосы гц	2) Среднегеометрические частоты гц
37,5—75	50	50—100	75
75—150	100	100—200	150
150—300	200	200—400	300
300—600	400	400—800	600
600—1200	800	800—1600	1200
1200—2400	1600	1600—3200	2400
2400—4800	3200	3200—6400	4800
4800—9600	6400	6400—12 800	9600

Key: (1). Frequency limits of the octave band Hz. (2). Geometrical mean frequencies Hz.

Page 36.

Of the holes of channels, which publish noise in the atmosphere:

a) at a distance 1 m of the edge of the hole of channel in output plane;

b) at four points around the building from which is derived the channel, at a distance 10 m of the walls of building and height/altitude 1.5 m of the earth/ground.

In the calm production locations where the noise level does not exceed 75 dB, one should conduct the measurements only of loudness level in backgrounds without the construction of noise spectrum.

NORMALIZATION OF NOISE LEVEL IN PRODUCTION.

According to work, conditions to completely eliminate the harmful effect of noise is impossible. It is necessary to conduct active fight for reduction in the noise and the limitation of acceptable noise levels in production for the target/purpose of the protection of the organ/control of audition from regeneration and destruction.

The "time/temporary sanitary norms and the rules on the limitation of noise in production", affirmed GGSII of the USSR on 9 February 1956 (No 205-56), establish/install the permissible boundary/interface of noisiness for the existing types of mechanisms and technological processes taking into account realization under production conditions of the now known technically attained measures for a reduction in the noise.

Gradation of the harmfulness of production noise it is expressed during the determination of the classes of noise, for each of which is establish/installated its tolerance level (Table 12).

Supplementary necessary conditions to the indicated tolerance levels and the spectra is the intelligibility of speech, which must be satisfactory under conditions of the noises of all three classes, namely: the multiple-digit numbers, pronouncing the voice of normal volume, must be good audible at a distance 1.5 m of speaker.

Table 12.

(1) Класс шума	(2) Характеристика шума	(3) Допустимый уровень шума дБ
(4) Первый	(5) Низкочастотные шумы (шум тихоходных агрегатов неударного действия, шумы, проникающие сквозь звукоизолирующие преграды — стены, перекрытия, кожухи) — наибольшие уровни в спектре расположены ниже частоты 300 гц, выше которой уровни понижаются (не менее чем на 5 дБ на октаву)	90—100
(6) Второй	(7) Среднечастотные шумы (шумы большинства машин, станков и агрегатов неударного действия) — наибольшие уровни в спектре расположены ниже частоты 800 гц, выше которой уровни понижаются (не менее чем на 5 дБ на октаву)	85—90
(8) Третий	(9) Высокочастотные шумы (звенящие, шипящие и свистящие шумы, характерные для агрегатов ударного действия, потоков воздуха и газа, агрегатов, действующих с большими скоростями) — наибольшие уровни в спектре расположены выше частоты 800 гц	75—85

Key: (1). Class of noise. (2). Characteristic of noise. (3).

Acceptable noise level dB. (4). The first. (5). Low-frequency noises (noise of the slow aggregate/units of unstressed action, the noises, which penetrate through sound insulating barrier/obstacles - wall, overlaps, jackets) - the greatest levels in the spectrum are arranged/located below the frequency 300 Hz higher than which levels are depressed (not less than on 5 dB to octave). (6). The second. (7). Middle frequency noises (noises of the majority of machines, machine tools and aggregate/units of unstressed action) - the greatest levels in the spectrum are located lower than the frequency 800 Hz, higher than which levels are depressed (not less than on 5 dB to octave). (8). The third. (9). High-frequency noises (ringing,

sibilant and whistling noises, characteristic for the aggregate/units of percussion, the air flows and gas, aggregate/units, which effect at high speeds) - the greatest levels in the spectrum are located are higher than the frequency 800 Hz.

Page 37.

If of 50 named numbers more than 40 are taken correctly, then intelligibility is considered satisfactory and this noise does not exceed permissible.

For the calm production locations, arrange/located in the territory of plant, design bureaus, office and administrative locations in private and windows the level of permissible noise level, which penetrates into this location from other production locations, it must not exceed 50 backgrounds of outside dependence on its frequency composition.

Procedure of the determination of acceptable noise level from the curve/graph of norms.

After measuring the common/general/total level of noise strength in decibels with the aid of objective audio-noise meter and the frequency noise spectrum in decibels with the aid of audio-noise meter and the connected to it filter one should construct from measurement data noise spectrum on tracing paper to the scale, identical to the graph of norms (Fig. 20), for which:

a) to plot along the axis of abscissas the geometric mean frequencies of filter (from Table 11);

b) on the ordinates of graph, corresponding to geometric mean frequencies, to plot down from zero decibels the measured values of the noise levels in bands.

Note. For zero decibels, it is possible to accept greatest of the measured levels in the spectrum and to set aside the difference between the greatest, levels in the spectrum and by the remaining levels in spectrum bands.

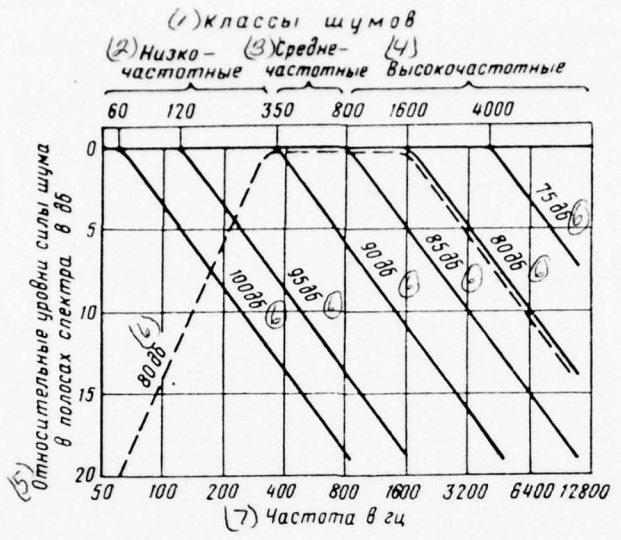

Fig. 20. Acceptable noise levels in production for noises of different classes (graph of norms).

Key: (1). Classes of noises. (2). Low-frequency. (3). Middle frequency. (4). High-frequency. (5). Relative levels of noise strength in spectrum bands in dB. (6). dB. (7). Frequency in Hz.

Page 38.

The graph of norms is combined with the constructed graph of noise spectrum by the imposition of tracing paper on graph (see Fig. 20).

Noise is considered permissible, if the line, spectrum envelope of noise, it does not fall to more than 3 db outside boundary line of the graph of norms, which corresponds to the measured by audio-noise meter common/general/total level of noise strength.

COLLECTIVE AND INDIVIDUAL PROTECTIVE MEANS FROM PRODUCTION NOISE.

Transfer/converting to the practical measures of fight with production noise, one should say that its success will depend in large measure on its organization.

The present effective fight, which guarantees lowest possible noise levels in production, must begin considerably earlier than the

launching/starting of new shops and production, earlier than the issue of machine tools and mechanisms. In this case to the development of the combat means, it is necessary to draw the technical-engineering workers of the design and planning organizations of the machine building industry, technologists and specialists, who participate in the creation of constructions and the composition of projects, and also the representatives of the organizations, which confirm new constructions and projects.

In the effective shops and productions, the noise abatement must be done simultaneously with the different in character noise sources, which are already located in the flow of production.

Measures for fight with production noise it is accepted to divide into three categories:

1) measure for a decrease in the level of production noise to the maximum permissible norms in the effective shops;

2) technical requirements with respect to noise abatement of new machines and mechanisms;

3) the technical specifications of the planning of noisy productions.

AD-A051 953

FOREIGN TECHNOLOGY DIV WRIGHT-PATTERSON AFB OHIO
MEANS OF DEFENSE FROM PRODUCTION NOISE, (U)
JAN 78 A S PALASHEVSKAYA
FTD-ID(RS)T-2316-77

F/G 6/10

UNCLASSIFIED

2 OF 2

AD
A051 953



NL



END
DATE
FILMED
4-78
DDC

Measures for a decrease in the level of production noise to the maximum permissible norms in the effective shops in each individual case must be defined after the visual inspection of mechanism both in that which effects and in the inactive state, and also after obtaining of the acoustic examination/inspection of production conditions of this work area, shop, production and analysis of the components of noise. Only in this case the determination of reasons will be considerably lighten and the measures, directed toward the liquidation of these reasons, will bring the greatest results.

Measures for a reduction in the production noise in active shops.

In all production locations where the noise levels on work areas exceed permissible, must be accepted measures for insulation/isolation of noise source, prevention of the propagation of vibration and its emission/radiation, for sound absorption by special devices.

The sources sharply emitted noise (mechanisms, installations, aggregate/units, processes) must be insulated by means of their conclusion/derivation into separate locations or by the installation of special dense wooden or brick partition/baffles with the transference of control panel for partition/baffle.

Brick partition/baffle into one brick gives a reduction in the noise to 43 dB, and in one and one-half brick - to 49 dB¹.

FOOTNOTE ¹. The effect of the sound-proofing devices and all measures is given on actual measurements after implementation. For varied conditions and with the different by execution the effect can be changed within limits of ± 3 dB. ENDFOOTNOTE.

If it is not possible to insulate noise sources, one should establish/install near them the soundproofed cabin/compartments for servicing personnel with control panel and inspection window (two- or by the three-layered pressurized/sealed glazing).

The wooden tightly closed cabin/compartament decreases noise by 30-40 dB.

Test benches for small engines insulate by the special sound-proofing chambers from dense tree on to glue (without the application/use of nails) wall thickness from 20 to 25 mm. This chamber decreases noise by 18.5-20 dB. The sound-proofing chamber can be double from intermediate air interlayer without facing and with the lower covering from sound-absorbing material; there can be the chambers and the special constructions (Fig. 21).

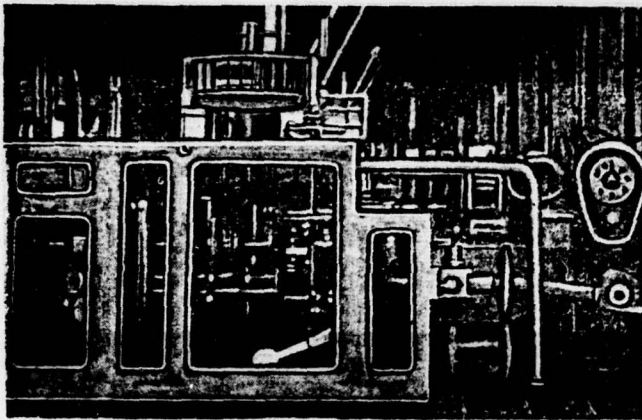

Fig. 21. Jacket of special construction with glazing for packing automatic machine.

Page 40.

As sound-absorbent materials for the walls, the overlaps, the chambers, the chests, jackets, etc., one should apply material without pores, with high acoustical resistance and the coefficient of sound absorption, which does not exceed 0.10/0. To such materials they are related:

a) brickwork into half-brick (12 cm). plastered from two sides by cement mortar, decreases noise by 46 dB;

b) concrete and the reinforced concrete with a cast thickness of 80 mm - decreases noise by 44 dB;

c) the same thickness of 110 mm - decreases noise by 47 dB;

d) double wall of two layers of gypsum plate/slabs 8 cm in thickness, placed close, decreases noise by 44 dB;

e) the same with interval/gap in 6 cm - decreases noise by 49 dB;

f) the same with interval/gap in 10 cm - decreases noise by 51 dB;

g) wall from pine wood panels 4 cm in thickness, plastered by calciferous-gypsum solution/opening, decreases noise by 30 dB;

h) the cork board with a thickness of 50 mm - decreases noise by 20 dB;

i) plywood with a thickness of 3.2 mm - lowers noise to 17 dB;

j) glass mirror with a thickness of 3-4 mm - lowers noise to 28 dB.

As sound-absorbings material for an internal facing, is applied hair felt - with layer 25 mm, it gives supplementary reduction of noise on 7.1 dB, with layer in 50 mm a reduction increases to 10.5 dB; are applied also cotton, oakum, asbestos, the slag cotton and another sound-absorbings material.

Sound-absorbing material is held from within by fine/thin wire gauze, the perforated/punched cardboard or the perforated/punched plywood, which are fastened to internal wall short, those who not pass through wood screws.

The double chamber design, coated by sound-absorbing material, decreases noise to 47 dB.

For convenience in the operation, the chamber can be carried out number system by lift inspection window, with the hermetically built-in two-layer glazing, which rests in all places of joint on sound-absorbing packing of felt or rubber.

Sound-proofing effect of inspection window with single glazing 16 dB, number system by double glazing - 20-30 dB.

The chambers for the aggregate/units, which require free air circulation, can have branch connections, included in ventilation system, or diversion/taps in the form of the pipes of varying section, directed to sex/floor or ceiling.

Sand-blast cabinet from gland (number system by the rubber hoses for a work within it) for purification/cleaning of parts, coated with inside technical felt under metal grid, decreases noise level to 33-35 dB.

The noise of the engines of separate assemblies or parts of aggregate/unit is decreased by means of insulation/isolation by their metal casing (Fig. 22).

Jackets are manufactured of of 2-3 millimetric iron of welded construction with dense fastening to supporting/reference wooden plate/slab or the flange through the insulating greased packing. This jacket decreases noise to 15-18 dB.

Page 41.

It can be made in the form of housing of veneer with 2- or 3- layer metallic or wooden inserted panels instead of the walls with packing of technical felt.

Jacket for insulation/isolation of tone noises (crushers, ball mills, etc.) can be made of two layers of a 10-millimetric plywood with that laid between them by the tightly connected and riveted on welds linoleum with a thickness of 5 mm, by plywood or plug plate. This jacket raises the effect of a reduction in the noise to 25 dB and more.

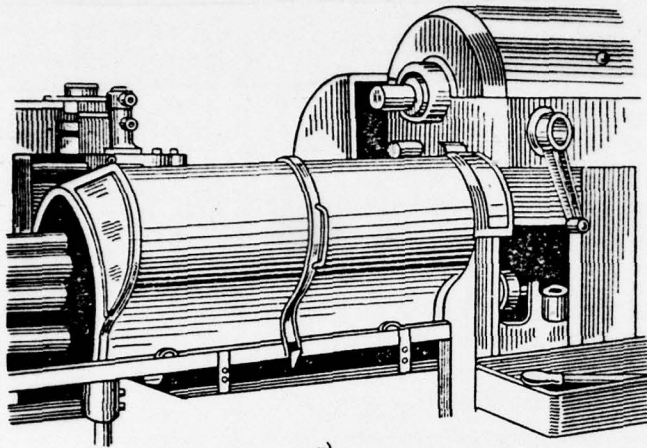

a)

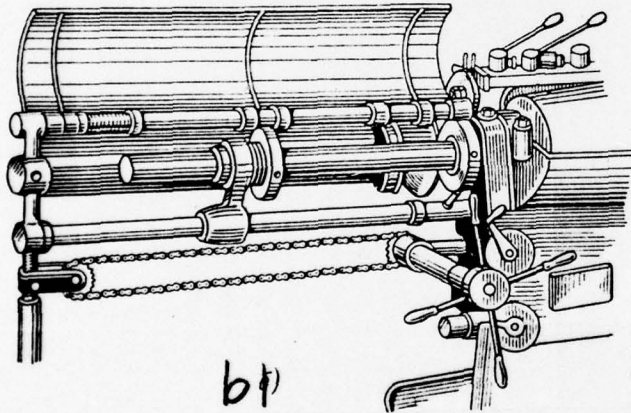

b)

Fig. 22. Machine tools with noise-reducing hinged/reversible jackets.
a) Device with enclosed casings, b) machine tool with
hinged/reversible jackets.

Page 42.

Jacket can be hinged/reversible, on loops, hangers, etc. In all cases the supressing ability of jacket will depend on the seal of structure and its fastening (Fig. 23).

Insulation/isolation of the tumbling barrels, ore crushers, spherical grinder, etc. can be realized by the device of special chests with individual sections.

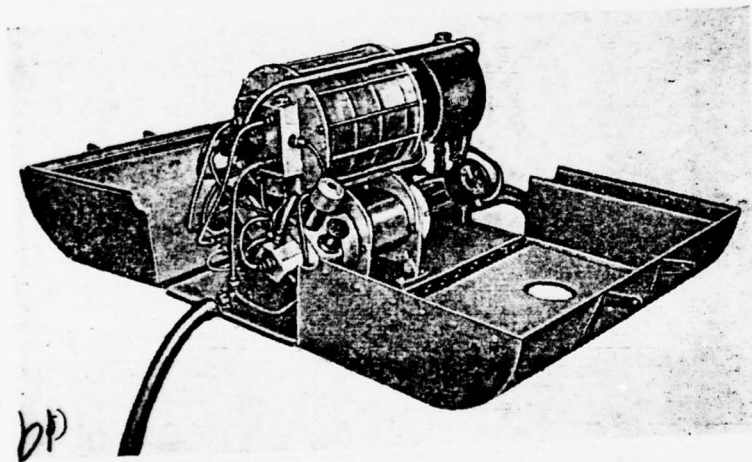
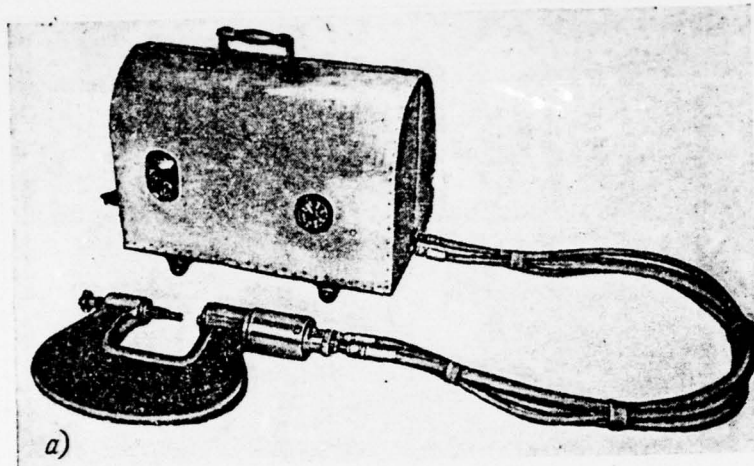

Fig. 23. Pneumatic aggregate/unit PGA-6 with hinged/reversible jacket to movable riveting presses. a) in running order, b) in nonoperating state.

Page 43.

Chests can be manufactured according to the type of the chambers with dense single either double door or lift cap/cover. Within the chest of a sufficient size/dimension, is installed the foundation, drives and another necessary equipment. This device of single chest provides a reduction in the noise to 20-35 dB, and double with the sound-absorbing facing - to 50 dB.

Furthermore, the tumbling barrel can be dressed into "jacket" from sheet rubber with the sheathing/skin of surface by the strips of wood, which tightly press jacket by bands or clamps (tie pieces) over entire drum surface.

A reduction in the noise of the tumbling barrels (in foundry shops) is achieved by installation within their second grid from armored plate/slabs with the air seal in 2-3 cm. Simultaneously from the external drum surface is placed the layer of rubber, strengthened with the aid of transverse continuous block/backings under metallic belt/zones.

The impact noises, accompanied by powerful shaking and vibration of aggregate/unit (hammers, hot-die-forging, forging pneumatic, knockout or landing/heading automatic machines) and by the emission/radiations of powerful air waves, require special measures for the prevention/warning of the propagation of vibration to vibration insulating parts of the construction and beyond the limits of machine tool.

As the vibration-isolating materials it is possible to apply:

a) rubber porous, soft, in the form of ribbed slabs or plate/slabs with holes; rubber of average hardness; rubber of special types;

b) plug natural or plug grit in the form of plate/slabs;

c) felt soft; felt rigid pressed and felt with the layer of plug;

d) mineral felt on the bituminous bonding agent, manufactured in the form of the fabrics with a thickness of 3-5 cm, by the width of 1.5-2 m and by the length of 3 m;

e) the asbestos-cement plate/slabs with a thickness of 3 cm from

the mixture of 50o/o asbestos and 50o/o of cement, dissolved by water;

f) plate/slab from mineral plug 3 cm in thickness, manufactured from the slag cotton with the treatment by emulsion;

g) wood-fiber boards 2.5 cm in thickness, manufactured from production wastes of wood pulp at paper and pasteboard factories.

Packing of felt under machines it follows periodically - through 2-3 years, and rubber after 4-6 years - to replace new.

Remaining materials as more to strut can be replaced with necessity.

The prevention/warning of the propagation of vibration beyond the limits of impact constructions (hammers forging, knockout machines, etc.) is achieved by the device of the attenuating foundations (Fig. 24). For powerful assemblies the foundations work into the earth/ground to 900-1000 mm and more.

Page 44.

Into the bottom of the coated with brick planking, it is filled and

is tamped layer of sand or gravel above which along foundation are laid cross ties at a distance 300-400 mm one from another and on them, rests concrete foundation. Above concrete cushion with the poured in it bolts for fastening of the foundation of machine tool, is laid a layer of mineral felt on bituminous bonding agent 15 cm in thickness and oaken block/backing 70-100 mm in thickness, that corresponds by area to the basis/base of machine tool.

Machine tool can be establish/installed and to the spring or rubber fenderings (Fig. 25) of welded construction (construction of spring shock absorbers is developed LIOT, and two-spring with rubber packings - NISO).

During the assembly of machine tool on shock absorbers for the target/purpose of the prevention/warning of sound emission by foundation level it is required to bring under the basis/base of machine tool with two-layer sound-absorbing packing of of wood-fiber or cork board and rubber (Fig. 26).

Under knob/caps or nuts of mounting bolts, which strengthen machine tool to foundation, it is necessary to place rubber and metallic washers, and to pain - to put on rubber tube or to leave air gap. Fastening must rigid link aggregate/unit number system with foundation to avoid emergence and transmission of vibration.

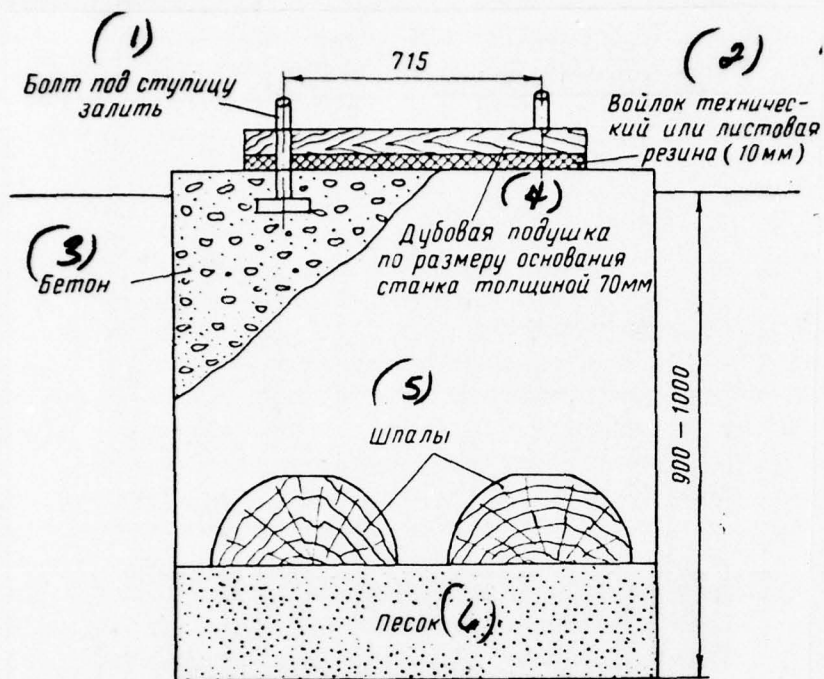

Fig. 24. Foundation of knockout machine tool BSh.

Key: (1). Bolt under hub/boss to pour. (2). Felt technical or sheet rubber (10 mm). (3). Concrete. (4). Oak cushion according to the size/dimension of the basis/base of machine tool 70 mm in thickness. (5). Cross ties. (6). Sand.

Page 45.

In the places of the greatest emission/radiation of vibration by

machine tool - on arm, thinning projections, indentations, legs, struts, the escapes of design, receiving shocks, to all metallic "waists" for a decrease in radiating surface of machine tool or attachment one should install with interference circular rubber sleeves, clutches, beaker/sleeves or tighten the closely fitted layer of rubber, pressing it by wooden or metallic washer and fastening by tightening bolts or clamps (Fig. 27).

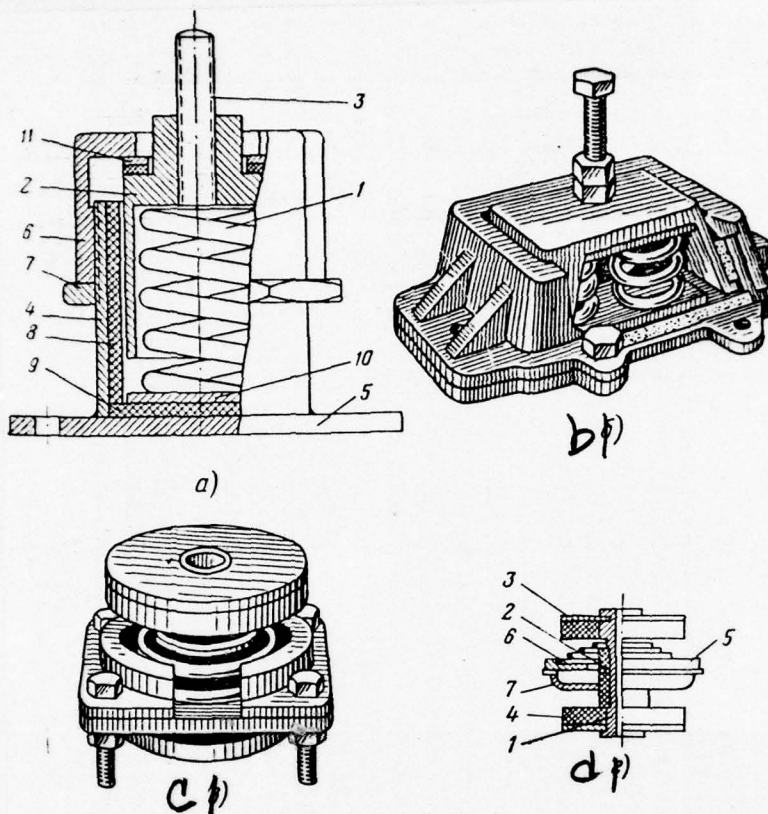

Fig. 25. Vibration-damping supports. Constructions of spring shock absorbers. a) Shock absorber LIOT. 1 - cylindrical spring, 2 - supporting/reference machine tool, 3 - the fastening bolt, 4 - housing, 5 - area/site, 6 - nut for preliminary tightening, 7 - nut lock, 8 - bushing of rubber, 9 - the cushion of rubber or plug, 10 - supporting metallic disk, 11 - metallic and rubber washers. b) two-spring shock absorber with rubber packing. c and d - general view and the cut/section of an equifrequent shock absorber of the type NISO-B. 1 - strut-bushing, 2 - rubber tube, 3 - washer, 4 - buffer, 5 - basis/base, 6 - exponential spring 7 - cover plate.

Page 46.

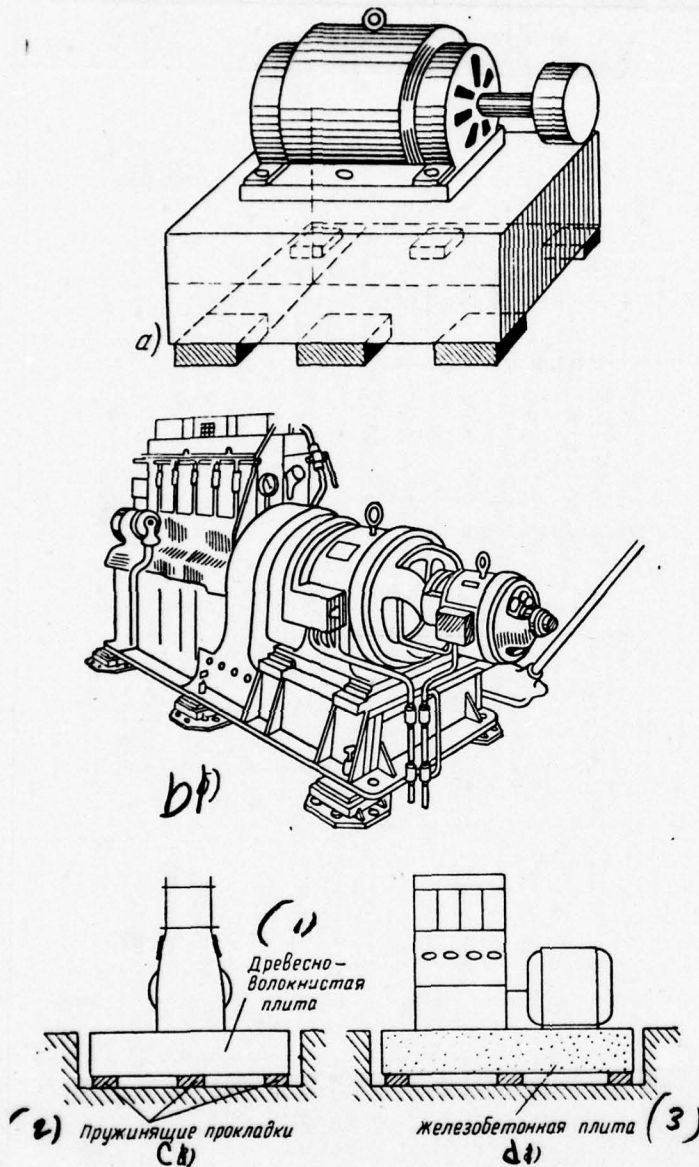

Fig. 26. Vibration damping elastic and spring cushions. a—the mounting method of machines on cushions, b—an example of the setting up of generator on spring shock absorbers, c and d - combination of

plate/slab and machine is establish/installed to resilient mountings.

Key: (1). Wood-fibrous plate/slab. (2). Spring packing. (3). reinforced concrete plate/slab.

Page 47.

Tool making tables, the joiners benches, carrying large impact load, one should cover/coat the top with linoleum, fiberglass, plastic or polychlorovinyl plates, fastening them to edges of the table narrow (10 x 10 mm) corner angle from the tin plate.

Under entire that installed on tables or joiners benches tool making tools and trueing attachment of iron sheets, their bending by hand on plate/slab, rail or the stream of square section/cut, with knockout on figure models, anvils or in jaws under the basis/base of the attachment between the plate/slab and the machine tool, and also under the washers of the fastening bolts should place two-layered attenuating lining from sheet of asbestos and mineral felt on bituminous basis/base or from rubber (Fig. 28).

During working of large metallic planes or cavity articles (boilers, the cisterns, the containers and other large-size

capacitance/capacities from sheet metal) by means of pneumatic riveting, which creates high noise level both within the capacitance/capacity and snaruji, the resources of attenuation are difficult.

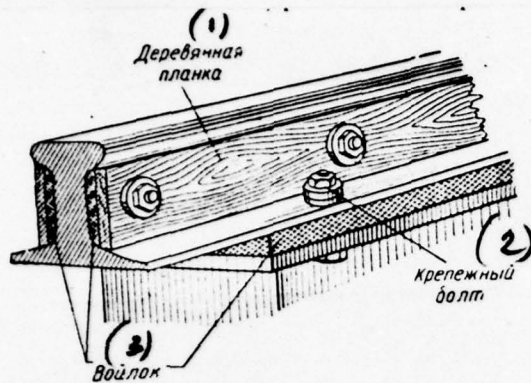

Fig. 27. Damping packings in thinning of rail (felt is held by wooden washer and bolts).

Key: (1). Wood plate/bar. (2). Fastening bolt. (3). Felt.

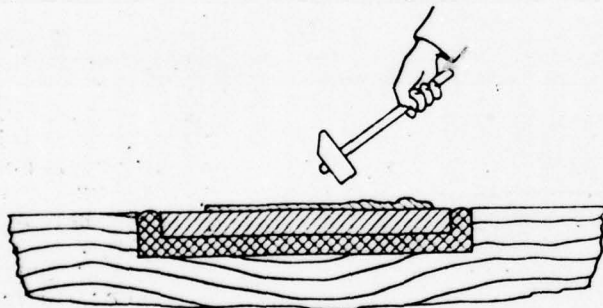

Fig. 28. Damping packings under straightening plate/slab.

Page 48.

As the most rational resource in such cases can serve the coating of

an entire surface of article with several layers of varnish or latex (synthetic rubber), which after drying in the open air will leave on metallic surface fine/thin (to 1 mm), but having large coefficient of friction, and consequently, vibration-damping film of artificial coating, which does not mix work.

As the resource, which reduces the plane of the emission/radiation of air waves and absorbing them, can serve the application/use of panels (of type of blankets) from the double layer of ATIMKh-15, cotton with the fire-resistant impregnation with antipyrine (OP) and coated from upper side of dressed linen ANZH or AM 100-OPZ with dense surface film. Such panels are opened according to the size/dimensions of article, are face/trimmed on edges by the weld of overlock or with knee to another side to 15-20 cm (Fig. 29).

When article is very great, is manufactured several panels of small size/dimensions (4 x 4 or 4 x 5 m) and they throw them on the plane of article, overlapping each other. If necessary to free place for the treatment of panel it is easy to move.

The same panel, double (inside by oil cloth surface) for the absorption of high-pitched sound, can be hung up along great capacities. If workers are located within machined capacitance/capacity, then panel they hang up in it along diagonal.

Noise from the shock of instrument in the work of slotting and knockout machine tools can be lowered by means of attachment on bracket (higher than the instrument) with the aid of the clamping collar of rubber beaker/sleeve 2-3 mm in long lower than cutting or working edge of instrument.

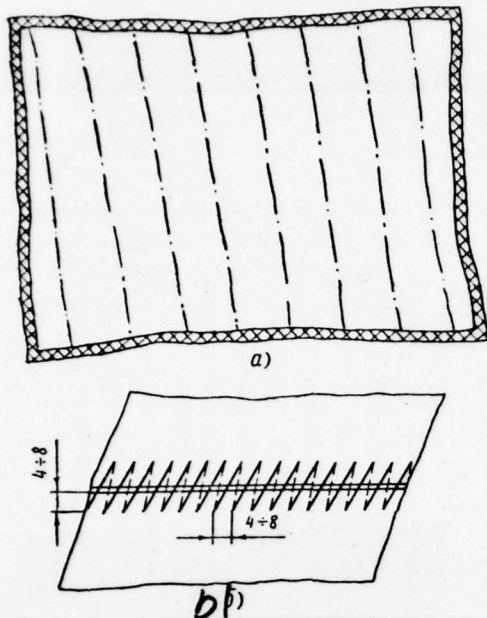

Fig. 29. Sound-absorbing panel. a) the weld of overlock, b) weld in the sites of joint.

Page 49.

the mechanical noise, which appears in the work of mechanisms on idle or working course (in catching of toothed wheels, in the work of cam/catch/jaws, from the shocks of pushers on valve stems, from the work of crankgear), of automatic machines on the manufacture of parts cutting, etc., and also with technical shortcomings in the mechanisms (into the result of eccentricity, internal slants,

incorrectness of assembly or wear of parts) is decreased by the way:

a) the elimination of technical defects and malfunctions in mechanisms;

b) testing undercarriages, their fastening and correctness of assembly;

c) the elimination of play, slants, lack of balance of motion work and their correct fixation, decrease in the range of oscillation;

d) timely repair and the replacements of the worn out parts;

e) the replacement of serrated straight-toothed wheels with gears with herringbone tooth;

f) increase of the width of gears;

g) the selection of the relationship/ratio of the teeth of gears;

h) the replacement of metallic gears and their alternating coupling with serrated oscillations from nonsonorous materials:

fibrolite, ebonite, Textolite, plastic, artificial leather, etc;

i) the regular lubrication of motion work;

j) the replacement of transmission drive by electric motors;

k) the application/use of the sound-proofing hinged/reversible jackets in noisiest locations (reduction, chain/catenary, belt, etc. transmissions);

l) of the automation of the supply of material;

m) systematic planned supervision after the state of the stock of machine tools in operation.

A reduction in the noise, which appears from the cutting forces, is achieved by lubrication (oil, emulsion) or by the execution of works in oil baths.

Much higher noise appears during the mechanized, and also hand finishing of articles made of the alloyed or light alloys, with alternating/variable section/cut, internal projections or cavities, the center-of-gravity disturbance and other deviations from norm. For the limitation of their vibration treatment it is necessary to do in

attachments, creating the densest adjoining to the attachment of radiating surface of part. If attachment is not closed entire radiating surface of part, then it one should tighten by the steel clamps of various forms and size/dimensions (place), by the equipped sectors from rubber or bituminized felt, strengthened from inside of clamp on the recessed into material rivets or the bolts, which emerge outside. The tension of clamps (Fig. 30a) is regulated by tightening bolts. A quantity of clamps is determined by the size/dimensions of article.

Also descends the sounding of steel tubes during their internal treatment (Fig. 30b).

Page 50.

During the external working of ducts, the limitation of the propagation of vibration and sound emission is achieved by driving in inside the ducts of wooden plugs with rubber packing, and also spacers with the spiral control of pressing rubber or felt interlayers against the internal surface of duct. During the treatment of edge or it is end duct it is possible to utilize an external and internal method of silencing.

Parts with alternating/variable section/cut or the special

consumption/production/generation of the complex configuration, which have sharp and thinned strongly vibrating cell/elements (blade/vane of turbines, the blade wheel of compressor, etc.), require special attachments for the vibration damping of these cell/elements - the setting up of a clamp-vibration damper, packing, clutches, the belt/zones, developed/processed usually in connection with place by way of working invention.

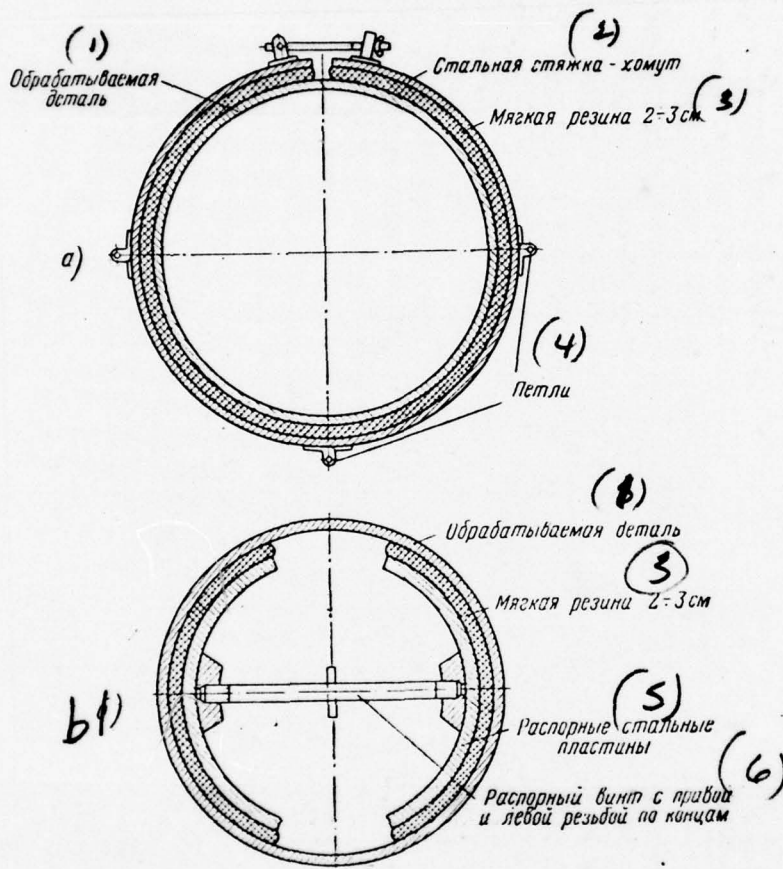

Fig. 30. Clamps (a) and internal spacing (b) during processing of ducts and different capacitance/capacities.

Key: (1). Machined part. (2). Steel tie piece - clamp. (3). Soft rubber 2-3 cm. (4). Loops. (5). Spacer steel plates. (6). Spacer screw/propeller with right and left-handed thread on ends.

Page 51.

One Of the specimen/samples of this clamp it is represented in Fig. 31.

The treatment of rounds of large length of automatic-revolver machine tools, which creates noise to 94-97 dB, is produced in special attachment - the directing ducts, coated from internal and face with the nonsonorous vibration-damping materials, or in the attachment, which consists of the ducts between which is placed the spring with the alternating/variable diameter of turns either with the filling of interval/gap by dry sand or with the filling of it with viscous fluid. The position of internal tube in this case is detented by rubber or wooden rings.

A reduction in the noise, produced by instrument, depends not only on lubrication, but also on the state of the instrument: from its timely replacement, sharpening, etc.

Pneumatic tool (pneumatic drills, pneumatic hammers, pneumo-cutters, etc.), the considerable noise created on leaving of

exhaust air (to 117 dB), at plants usually alter, equipping it with special silencers - the closed chambers for the expansion of the jet of the compressed air to its output/yield in the atmosphere (Fig. 32).

As this chamber it is possible to utilize also a cavity within housing. The best solution is the device of the chamber in the body of the housing of knob/stick (of shaft) with 12-15 additionally drilled outlets into 1.5-2 mm for a free air outlet to bit or milling cutter (Fig. 33). To lower the noise of the working shocks of pneumatic hammers thus far did not manage.

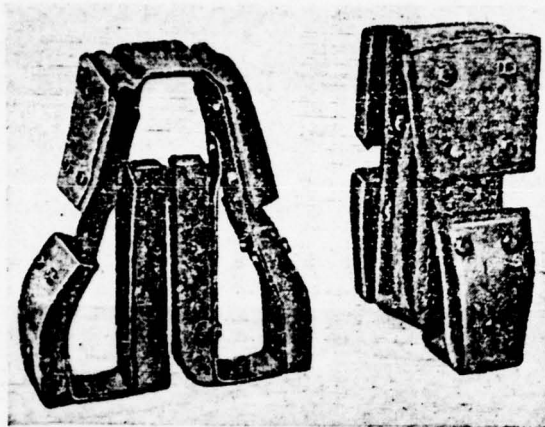

Fig. 31. Vibration dampers (clamps for blade wheel of compressor).

Page 52.

To a decrease in the level of production noise contribute also the preventive/warning inspection of attachments, testing stability and the elimination of the vibration of metallic parts by means of the stiffening of construction, the application/use of sound-insulating packing, lugs, sectors (prevent/warning emission/radiation and noise propagation), an increase in the density of the adjoining of article, reliability of fastening article, etc.

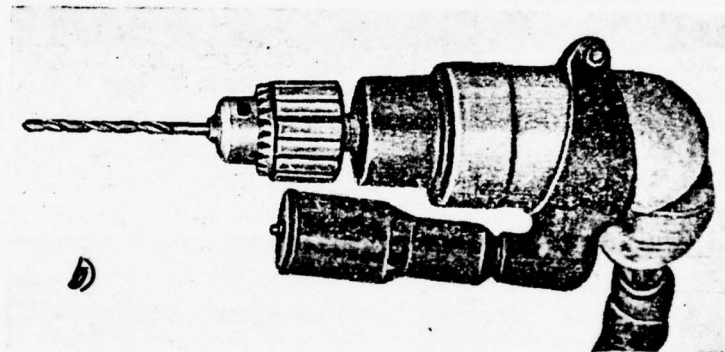
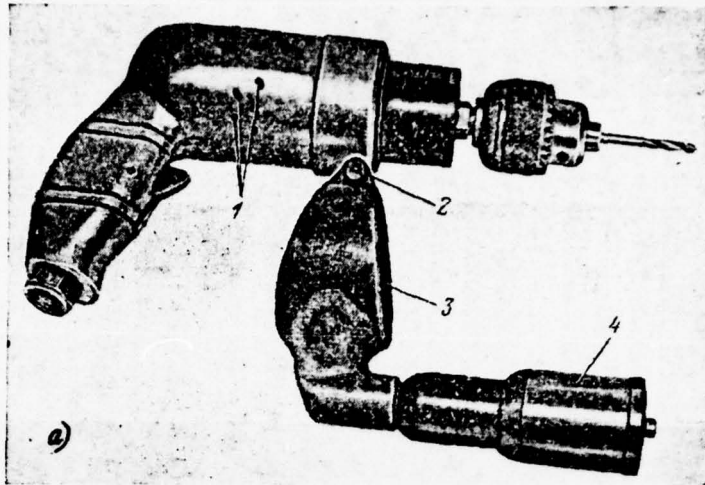

Fig. 32. Noiseless drill with removable silencing chamber: a) to assembly, b) in assembled form. 1 - hole for the admission of exhaust air into the chamber, 2 - tightening bolt, 3 - clamping collar

(binding band), 4 are silencing chamber.

Page 53.

The aerodynamic or hydraulic noise, which appears at high velocities of the flow of air, gas or liquids, during abrupt changes in the direction (during the flow about the blade/vanes on edges with rotations, the overcoming of obstructions) is somewhat decreased by the careful perfecting of the edges of fairings, increase in the evenness of junctions and change in the direction of flows, elimination of obstructions or imparting to them streamlined shapes.

Considerably reduces noise the device of the mechanical air outlet from sound source, if sound appears in the limited space. Thus, for instance, air outlet from under the jackets of the circular and saw bands through ventilation together with the distance/removal of dust contributes to a reduction in the noise.

Jet/reactive noise of continuous spectrum, which includes the sounds of all frequencies, more easily in all water curtain.

From the effect of the intense air wave of the time/temporary aerodynamic noise source, it is possible to be shielded by the

setting up before the worker of shield or partition/baffles with sound-absorbing facing.

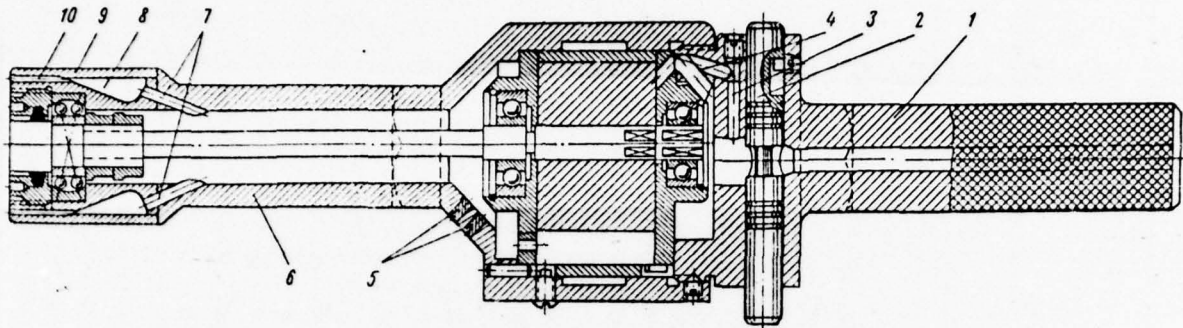

Fig. 33. Noiseless pneumatic drill with internal chamber: 1 - rear housing, 2 - valve, 3 - hole, 4 - wall of air chamber (removed), 5 - air holes in old construction of drill (are riveted), 6 - front/leading body, 7 - hole into air chamber, 8 - silencing chamber of noise, 9 - bushing, pressed to lever, 10 - new outlets.

Page 54.

The noise of ventilation systems can be considerably lowered during the execution of the comparatively simple measures:

a) during the elimination of technical shortcomings and malfunctions in the construction of fan and its conclusion into the

sound-insulating chamber;

b) during the motor installation on the durable weighted foundation (frame from channel bars, adjustable on sandy soil either the concrete cushion) or on the cushions (Fig. 34);

c) during static and dynamic balance, the elimination of eccentricities, lack of order of engine;

d) during the setting up of jacket on engine with its dense fastening for the frame through vibration-insulating packing;

e) with testing of methods and resources of fastening and insulation/isolation of air ducts, the renewal of asbestos and rubber packing, dense tightening and fastening by clamps (Fig. 35);

f) during testing of the soundness of air ducts, with connection of welds by electric welding, during setting up of flange joints with the sealing packing, air tubes and branch connections of rubberized fabric;

g) with the external soundproofing of air ducts by asbestos;

h) with the device of silencers in air ducts (facing and

shielding);

i) during setting up during the drawing of supplementary fan.

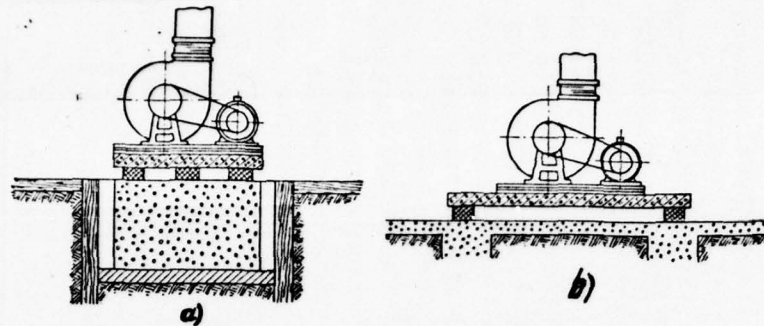

Fig. 34. Setting up of fans: a) on foundation in soil, b) during overlap.

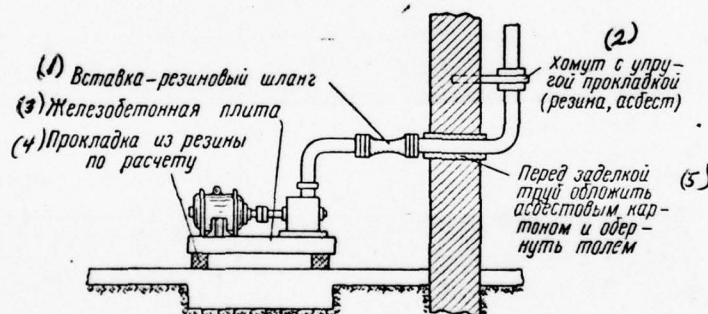

Fig. 35. Insulation/isolation of conduit/manifolds of fan from structure.

Key: (1). Inset is the rubber hose. (2). Clamp with the cushion (rubber, asbestos). (3). Reinforced concrete plate/slab. (4). Packing of rubber according to calculation. (5). Before the framing of ducts to assess by asbestos board and to wrap up roofing paper.

Page 55.

For special ventilation installations with the diameter of air ducts, which exceeds usual size/dimensions, one should apply the facing of the internal surfaces of air ducts by sound-absorbings material with a thickness from 2.5 to 10 cm (hair or mineral felt), that are held in mesh metal frames or by the fastened in thrust perforated/punched plywood, by transverse racks or interbracings (see Fig. 30b).

It is possible to apply also shell of the internal surfaces of air ducts by the acoustic slabs of a proper radius or configurations, fabricated and those who are assembled according to place. Slabs are connected with the aid of damp/crude accoustic plastering or adhere in to the walls of air duct by hot bitumen.

In the especially wide channels where the acoustic facing of walls proves to be insufficient, in the channel of air duct, are hung

the sound-absorbing plate/slabs and are establish/installed the shields from pumice or slag concrete, manufactured on metallic or lumber.

The setting up of shields or the suspension/mounting of plate/slabs must be subordinated to the requirement for the creation of the greatest number of bends in the direction of acoustic wave, possible elongation of its way between the sound-absorbing obstructions.

For large air ducts are applied the silencers lamellar with internal voids and bilateral facing. Their effectiveness - from 28 to 72 dB (see Fig. 37).

Are applied also the sections of honeycomb silencers with the sound-absorbing facing, which consist of the separate extended lacunar cells 10 x 10 cm by which overlaps the cross section of air duct and divide air flow to separate hose/pipes (see Fig. 36).

For a reduction in the noise of high frequencies (noise in the air ducts of fans, exhaust of engine, issue steam, etc.) are applied chamber silencers (see Fig. 38) with different type by shields (lamellar, cellular/honeycomb, honeycomb silencers). For powerful noises with continuous spectrum preferably the combination of

sound-filters and shields. For the damping of noise from issue, the pair from the narrow slot of nozzle is manufactured special iron box with the internal filling of interval/gap with mineral wool. This silencer decreases noise to 50 dB.

The noise of low frequencies, which appears during the expansion of gases and pulsation of exhaust pressure, descends with the aid of the acoustic filter-resonators, which have the built-in chambers with acoustic facing, in section/cut sweep of air duct 2-3 times (see Fig. 39), the allow/assuming series connection chambers.

The selection of silencer is determined by the value of required noise reduction and by the gas pressure after bleeder.

The noise, which appears during pressure change from compression during the suction of air, is decreased by applying the capacitive filter-silencers in the places of air intake. The places of air intake in this case they will be carried to the side.

Page 56.

In rotor-pressure system of air intake, one should remove also the mechanical noise of gear drive, interfering of rotors against each other, etc.

During the combined setting up from several uniform or diverse silencers, a reduction in the noise is equal to the sum of the reductions, obtained from each silencer.

Honeycomb silencers are manufactured in the form of separate cells with length 1-2 m. Each cell has the wire framework/body, turned by the sound-absorbing matte finish from felt with a thickness about 2-2.5 cm. Cells tightly are placed in series, they are bound by wire and are moved in into air duct or channel (Fig. 36). Effectiveness of honeycomb silencers from 33 dB - 82 dB.

Honeycomb silencers are manufactured also in the form of the cast sections from porous materials (Pumzolite, slag gypsum, etc.). Wall thickness in this case is not less than 2.5-3 cm.

Lamellar silencers consist of a series of the sound-absorbing plates, manufactured from porous plate materials or the sound-absorbing matte finishes (mineral felt), strengthened from all sides on wooden basis/base (Fig. 37).

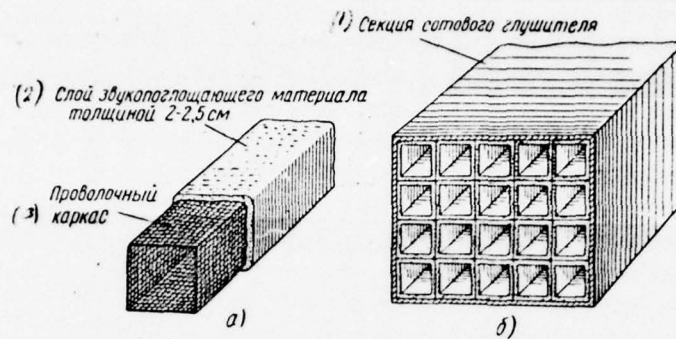

Fig. 36. Honeycomb silencers.

Key: (1). Section of honeycomb silencer. (2). Layer of sound-absorbing material with a thickness of 2-2.5 cm. (3). Wire framework/body.

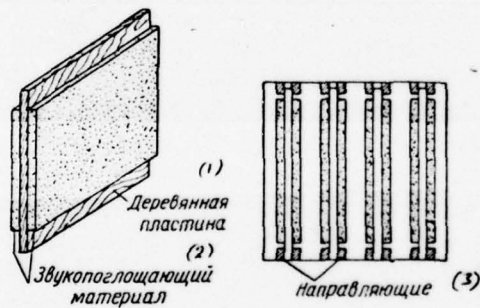

Fig. 37. Lamellar silencer.

Key: (1). Wooden plate. (2). Sound-absorbing material. (3). Directing.

Page 57.

The prepared plates are assembled on sections in lumber with the aid of guide bars of cassettes and are established/installed in the form of shields. For an increase in their absorptive power, the wooden basis/base of framework/body is made in the form of hollow box (air chamber).

Chamber silencers with internal shields are constructed according to different circuits (Fig. 38). Shields are faced by the mineral felt, fastened to basis/base with the aid of wire gauze.

For the damping of air or gas of motion above 6-7 m/s in speed transverse shields in the chambers they do not establish/install, being limited only laterally. All internal surfaces are faced by sound-absorbing material.

Acoustic filters are manufactured in the form of the hollow chambers, 2-3 times of those exceeding the section/cut of air duct (Fig. 39). The chambers are connected in the section on several of

pieces or are arranged/located along the way of the air duct through the determined (1-2 m) distances. In acoustic filters by sound-absorbing material are faced not the chambers, but their connecting channels. Acoustic filters are capable of attenuate/weakening the fluctuations of one or several frequency regions, suppressing and reflecting of driver with the frequencies of outside these regions. This property of filters is regulated by the size/dimensions of the chambers which are selected for a section virtually.

As sound-absorbing material one should apply porous and bulk materials.

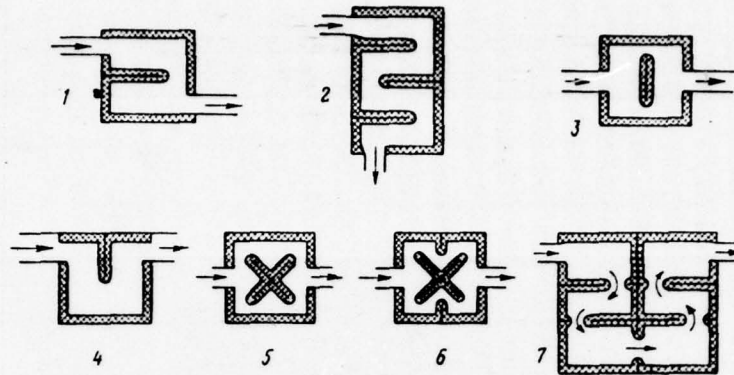

Fig. 38. Circuit of chamber silencers with shields.

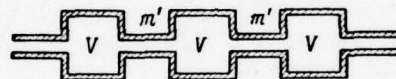

Fig. 39. Acoustic filter for low frequencies.

Page 58.

Especially high percentage of sound absorption have materials with the fibrillar structure of the structure of cells (with the internal voids through which they pass the finest fibrils):

a) felt construction with a thickness of 1.25 cm at average and high frequencies gives sound absorption to 45-52o/o;

b) the same, by the thickness of 5 cm, greatest sound absorption 69-67o/o gives at frequencies from 500-1000 Hz;

c) the same, by the thickness of 7.5 cm greatest sound absorption 66-77o/o gives at frequencies from 250-500 Hz;

d) the asbestos felt with a thickness of 1 cm absorbs sound to 32-25o/o at medium frequencies from 500-1000 Hz;

e) the glass-felt with a thickness of 3 cm gives 81o/o of sound absorption for the frequencies, close to 1000 Hz;

f) the slag cotton with a thickness of 10 cm also gives highest sound absorption 70-69o/o for a frequency 1000-2000 Hz;

g) the asbestos wool with a thickness of 10 cm after iron sheet with holes in 4 mm, the space of perforation 30 mm gives sound absorption to 70o/o at frequencies in 500 Hz;

h) panels of Bekesh 1 x 4 (linen on cotton) with a thickness of 4 cm they give sound absorption 80-81o/o at frequencies 125-250 Hz.

Of the holes of air ducts, which emerge into the corridors, one should establish/install the sound-proofing valves.

Of outlet above the corridor, is made special suspension with the hermetically closed hatch.

Between floors overlaps one should make heavier by filling.

A decrease in the resonance noise, which appears during fluctuations in elastic constructions during agreement with the vibrations of the external or internal sonic exciters, which increase the amplitude of oscillation, is achieved by a change in the speed or operating cycles of the aggregate/unit, calling resonance, by a change in the angle of incidence in its acoustic wave, by an increase in the rigidity or by an increase in the massiveness of the resounding part.

By the considerable on effectiveness resource of a reduction in the noise indoor is also the coating of the internal surface of walls, ceilings and farm/trusses the sound-absorbing compositions. For this purpose are applied porous acoustic plasterings, plate materials, the slag cotton, felt, asbestos grit, wood filings, etc.

In the metalworking shops the plastering will be deposited directly to the walls, pre-covered with the layer of cement plastering with a thickness about 10 mm.

The even damp/cruider layer of cement plastering is closed by the layer of acoustic plastering with a thickness in 25 mm. Acoustic plastering is manufactured as follows: construction slag or pumice is ground by hand or on mill and is sifted on grid with cells into 3 or 4 mm. Removed slag thoroughly is mixed with dry cement and fills with water before uniform moistening.

Page 59.

To one square meter of wall, it is required for 19.2 parts of the slag, 4.8 parts of the cement, 3.2 parts of water or 28.8 parts of the pumice, 7.2 parts of cement and 7.2 parts of the water.

The facing of the walls of the smithy, foundry, molding, chopping, stamping and other shops with the low-frequency noise of impact character it is better to produce with ready acoustic slabs. Plate/slabs are fastened to wall to hot bitumen or cement mortar.

As material for the manufacture of plate/slabs serves the solution/opening in proportions indicated above which is discharged into the forms with a depth of 25 mm, are aligned in them and through several minutes is sprinkled by water.

Plate/slabs are dried in air at temperature of 18-20°C during 2-3 days.

Iron farm/trusses and other metal constructions are cover/coated from pulverizer with the liquid mixture of the milled asbestos, glue and cement in proportion 4:1:1, by the dilute water to the required consistency.

Dampings one or of several tone sounds it is possible to attain by the device of the resonance systems, which consist of numerous separate resonators.

Resonators are clay or cups with narrow throat in the form of cylindrical and another form of cavities (Fig. 40).

Integral cavities are incorporated into walls and are filled to 1/3 by different sound-absorbings material: ash, by charcoal, by cake pumice, by graphite, etc.

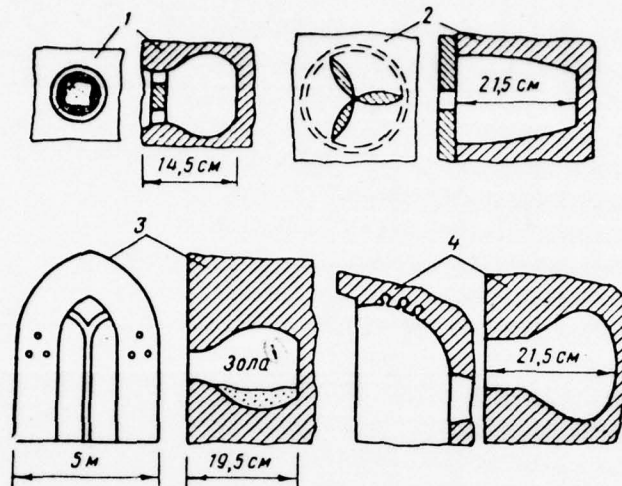

Fig. 40. Resonance sound absorbers of various forms: 1 - with square wooden plug in throat of resonator, 2 - with 3-lobe oaken plug, 3 - arrangement of resonators on wall of door, 4 - arrangement of resonators on arch/summit.

Key: (1). Ash.

Page 60.

Outlet of resonator is closed by the sound-transmitting material, and above - by the figure wooden plug of the square or other form, which

has holes for the penetration of air wave inside resonator (Fig. 41).

External resonators are made in the form of the mesh incomplete cylinders with the open lateral surface in which is fastened a series of disks from plywood on long legs, and they are hung near walls.

The loop branching in air ducts, which raise the distance, passable by acoustic wave to the odd number of halflengths of the wave of the suppressed tone, are also resonators and suppress noise.

In practice usually is applied the combination of the resonators of various forms. The system of resonators it is possible "to tune" for the frequencies, close to resonance, for absorption one or of several unpleasant sounds.

In locations with the noise of very high tones (in the shops of working light alloys, on the sections of testing and inspection/acceptances of signals or with the noise of aerodynamic origin) is made the soft facing of the surfaces of location in connection with the air damping. For this, according to the size/dimensions of each wall and ceiling, is made the wooden frame with a depth of 4-5 cm with transverse or longitudinal racks approximately through 1.5 m. Each frame is faced by the panel of the corresponding to it size/dimension (Fig. 42).

Form board is made of 2-3 layers of the material ATIMKh-15, rarely it is quilted and outside is covered by flannel. The edges of panel are face/trimmed by the weld of overlock (see Fig. 29). Such panels are tightened to the frames which then are establish/installed to ceiling and to walls. Hems in such locations are cover/coated first with one layer ATIMKh-15, and by the then carpet material ATIMK art. 131 (aircraft cover).

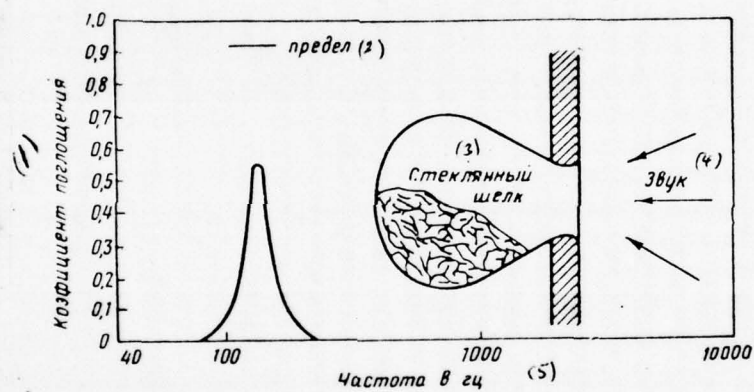

Fig. 41. Sound absorption by resonator sound absorber.

Key: (1). Absorption coefficient. (2). limit. (3). Glass silk. (4). Sound. (5). Frequency in Hz.

Page 61.

The depth of frame is determined depending on the frequency components of noise and can be from 2.5 to 10 cm.

The lower than the frequency, facts deeper must be frame (at frequency from 350 to 20 Hz the depth of frame must be from 6 to 10 cm, at medium frequencies from 350-1000 Hz, the depth from 4-6 cm, at high frequencies - is below).

Very high walls and the ceilings of special locations face for the sound absorption of the wide spectrum by felt, mineral or slag wool, asbestos, which are held on the surfaces of location by metal by grids or the perforated/punched (area of holes must not exceed 0.2 areas of material) sheets of plywood.

For an increase in the sound absorption the upholstering of walls with the aid of walls and the perforated/punched plywood one should alternate. This facing can be produced directly on wall, but for strengthening of its absorptive power, can it is fastened also to frames. In that case sound-absorbing material (felt, etc.) is placed

between two structural/design layers (grid) and is nailed to frame by nails.

For a reduction in the noise from in-plant transport, must be observed following:

a) rail tracks must be placed to the elastic vibration-insulating basis/base, and the joints of rails are to be welded;

b) the bridge fabric of the main roads, which pass on the territory of enterprise, must be cover/coated with asphalt; along the sides of the road should be provided for are sound-insulating green cultivations from the trees of leafy or coniferous rock/species.

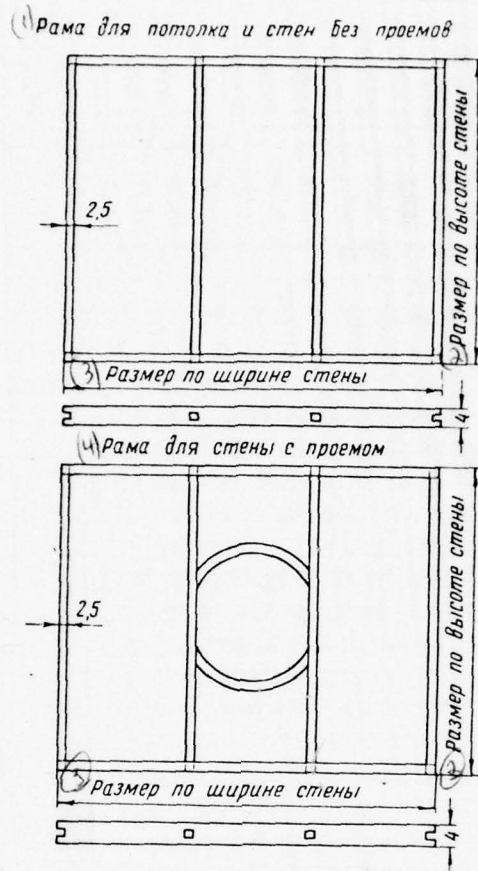

Fig. 42. Frame of air chamber for sound absorption.

Key: (1). Frame for a ceiling and walls without apertures. (2). Size/dimension on the height/altitude of wall. (3). Size/dimension in the width of wall. (4). Frame for a wall with aperture.

Page 62.

Individual protective means from noise.

Conducting of measures indicated above does not eliminate the need of applying individual attachments for the protection of the organ/controls of audition. The application/use of individual attachments serves the target/purpose of the weakening of acoustic wave by reflection and sound absorption of different frequency and intensity and thereby of a change in the noise spectrum, which reaches the organ/control of audition by sonic or bone reception. This eliminates the threat of the mechanical damage of the organ/controls of audition, it contributes to the weakening of the irritating noise effect on central nervous system, to decrease in the fatigue and to the prevention of emergence and developments of occupational disease.

The harmful effect of noise gave rise to the numerous forms of individual attachments for the protection of the organ/controls of the audition: internal plug/silencers from different materials (for the external auditory pass), antiphones, earphones, filters, helmets, caps, ties, and so forth from the different materials. However, the

hygienic and acoustic qualities of the resources of individual protection under conditions of contemporary production proved to be insufficient.

By the author is proposed the new form of the attachment for the protection of the organ/control of audition PAS-80 (Fig. 43), which consists of the pair of the plug/silencers, connected by cross connections of tape/strip (galenite) rubber, covering not only the pinna but also the located beyond it sound-transmitting part of the skull (temporal bone).

Each plug/silencer is two-layered: its upper part is pressed from the vinyl chloride plate with a thickness of 1.5 mm, which has the coefficient of reflection $\alpha = 0.7-0.85$, with its preheating to $110-125^\circ$; the second - from cardboard, who gives a reduction in the noise in the range of low frequencies on 28-33 dB. between them is made the packing of oakum (having the fibrillar structure of structure) or of felt (with the coefficient of absorption $\tau = 0.5-0.65$), impregnated with paste of wax and technical vaseline in equal portions (with the coefficient of absorption $\tau = 0.8-0.96$). For an internal facing is applied the silk low-napped velvet, which has air micropores.

Regulating units make it possible to achieve the uniform and

dense adjoining of attachment on the outline/contour of head.

Attachment sharply changes the character of production noise, it eliminates high-pitched sound, which effect on man on any level of production noise, it protects from the breakage of the eardrum, it does not allow/assume throughout workday of the appearance of "noise" in ears, fatigue, headaches, vertigoes, feelings of depression, i.e., create normal working order.

Attachment PAS-80 does not have metallic parts and provides the normal position of the pinna without pressure and any pains. It satisfies also aesthetical (does not deform of face and head) and hygienic (it is cleaned by fleece with gasoline or eau de Cologne) requirements, has weight 105-175 g.

Page 63.

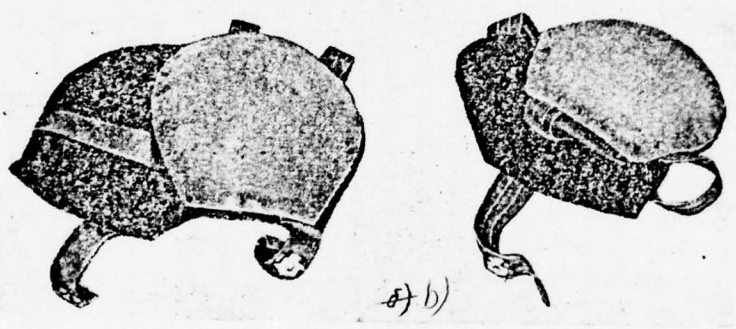
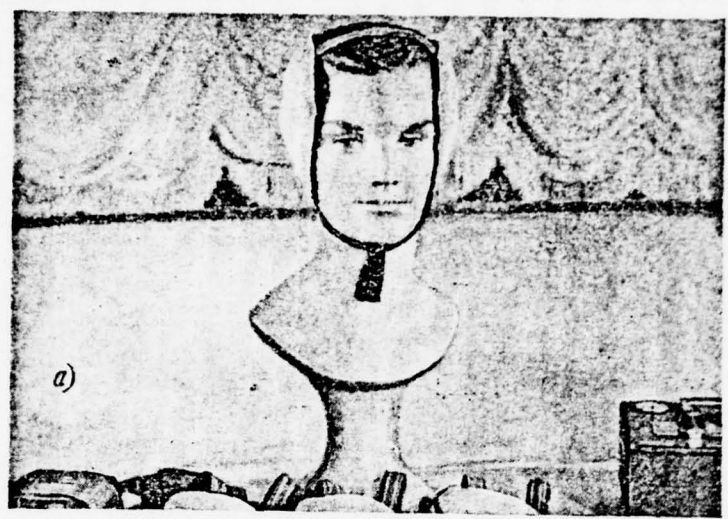

Fig. 43. Attachment for the individual protection of the organ/controls of audition PAS-80. a) in operating position, b) out-of-service.

Page 64.

The results of testing the suppressing properties of PAS-80 on thresholds of auditory sensitivity are represented in Table 13.

During correct control of the density of the adjoining of attachment, its suppressing ability is raised (Fig. 44).

Note. A change in the number of plug/silencer depends on a change in the filler between its gas inclusions.

Table 13

(2) № заглушки	(1) Частота в гц									
	125	250	500	1000	2000	3000	4000	6000	8000	10 000
	(3) Заглушение в дб									
ПАС-1	39	36	35	32	28	32	39	51	48	43
ПАС-2	39	36	32	25	27	31	41	53	55	49
ПАС-3	38	35	28	27	33	38	51	56	54	38
ПАС-4	32	30	22	21	25	30	48	50	50	40
ПАС-5	38	36	30	23	25	24	38	48	41	32
ПАС-6	41	39	33	28	28	29	37	23	23	38
ПАС-7	38	32	27	25	29	35	46	54	47	40

Key: (1). plug/silencer. (2). Frequency in Hz. (3). Damping in dB.

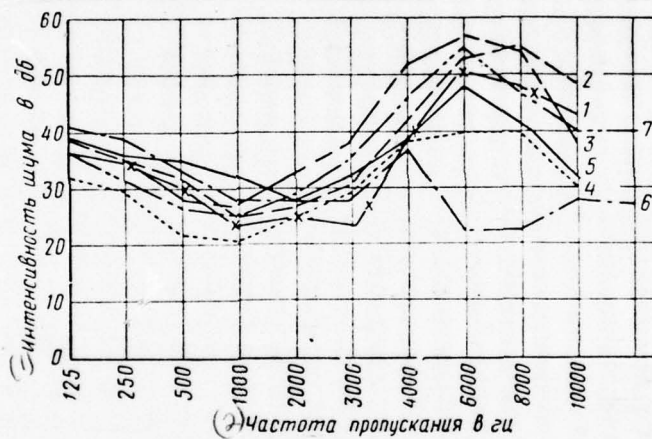

Fig. 44. Average result of testing the suppressing ability of PAS-80 on the thresholds of auditory sensitivity.

Key: (1). Noise intensity in dB. (2). Frequency of transmission in Hz.

Page 65.

Reduction in the noise in design bureaus, laboratories and office locations.

In the calm specially equipped with soundproofing and sound absorption locations of nonproductive designation/purpose (design bureaus, laboratories, etc.) the common/general/total maximum permissible noise level must not exceed 50 backgrounds. For the prevention/warning of the disturbance/breakdown of silence in such locations, it follows:

- a) to equip doors with springs with pneumatic regulator;
- b) to cover sex/floor or passes or cloth strips of carpet;
- c) to place rubber points to the supports (leg) of the moved furniture or inventory (chairs, movable joiners benchhes, benches, Kuhlmanns, etc.) or to cover with rubber the small wheels of legs;

d) to establish/install the noisy equipment of laboratory in the chambers or the vitrified cabinets with sliding doors;

e) to replace ejector settings up with ventilation system;

f) to lay plates from the hair felt among table and instruments, attachments, typewriter, etc.;

g) to mute telephone bells;

h) to conduct the service calls at half-voice, at a distance between collocutors on are more than 1 m.

After selection of one or the other resource of a reduction in the noise for each work area, is develop/processed working project by the efforts of engineering and technical personnel of this enterprise or special organization.

Measures for fight with production noise are included in the plan/layout for the organizational and technical measures of plant for the nearest period (subsequent quarter, year) and are checked by all collective of enterprise.

For the purpose of a reduction in the production noise should to

be carried out the reconstruction of the existing shops of special designation/purpose on the projects, developed by appropriate organizations.

TECHNICAL REQUIREMENTS WITH RESPECT TO NOISE ABATEMENT OF NEW MACHINES AND MECHANISMS.

The review of construction and the development of new noiseless or low-noise models of mechanisms must begin from research on the spectrum the bag of the effective specimen/samples, establishment of the reasons for emergence and emission/radiation of acoustic waves and determination of technical requirements for the construction.

The common/general/total level of the noisiness of machine tools, machines and production aggregate/units must not exceed 50 dB.

The common/general/total noise level of mechanism must be brought in into log book.

As beginning in the use of intact reserves and possibilities of a reduction in machinery noise one should count:

- a) the correct selection of the schematic of mechanism;
- b) the replacement of reciprocating motion of parts by rotary motions;
- c) the replacement of the percussion of parts and assemblies unstressed;
- d) a decrease in the tolerances and clearances in the articulation of parts;
- e) the careful balancing of all driving parts of aggregate/unit;

Page 66.

- f) the replacement of the machining of the parts of mechanisms by the manufacture of them by pressure casting, precision casting, investment casting and by other new technological methods of production;
- g) the replacement of metallic bearings by bearings from plastics or the pressed wood;
- h) the replacement of antifriction bearings by slide bearings;

- i) the coupling of metallic parts with parts from the nonsonorous materials: plastic, ebonite, fibrolite, Textolite, etc.;
- j) the replacement of narrow straight-toothed gears by wide with the herringbone or oblique arrangement of teeth, for an increase in the evenness of transmission;
- k) the selection of the number of teeth in accordance with musical intervals;
- l) insulation/isolation of the noisy assemblies of aggregate/unit (gear reducers, the chain, serrated and other transmissions, the colliding parts of engine) by means of conclusion into special bellows with the structural/design cavities, filled with damping materials (oil, the slag cotton, asbestos grit, etc.);
- m) the replacement of gear reducers by hydraulic reducers, the chain/catenary either gear drives - by frictional or hydraulic;
- n) the insertion of the noisy assemblies of aggregate/unit to oil baths;

o) the careful assembly of aggregate/unit, the exception/elimination of slants, eccentricity, etc;

p) the application/use between the parts of packing (impregnated cardboard, plug, asbestos, rubber) and of spring damping washers in the places of flexible members;

q) the automation of launching/starting, stop and machine-tool control;

r) an all possible decrease in the surface of the reverberating parts of the mechanism;

s) sound-proofing of the internal surfaces of the housing of noisy aggregate/units by acoustic facing (nailmaking, braiders, machine tools for working of hour stones, diesel and electric motors);

t) the facing of the external surface of the housing of the aggregate/unit, cap/covers, jackets and other exteriors by spackle, by paint and varnish for a reduction in the radiating capacity;

u) the provision for a mechanism with the assembly of the rapidly worn parts and with command on correct operation.

For the prevention/warning of the appearance of jolts and and noise-formation after arrangement/permutation and equipment installation in shop, it is necessary:

a) the arrangement/permutation of noisy aggregate/units and entire relating to them equipment to produce in separate locations, after the sound-proofing partition/baffles, in the chambers, the chests, the sections, which allow/assume control by aggregate/unit and observation of its work;

Page 67.

b) each mechanism, calling jolts, to establish/install in individual foundation with damping packings or to the spring shock absorbers with sound-insulating block/backing under basis/base;

c) during assembly to establish/install personal responsibility for correct fixation of mechanisms, for density and reliability of fastening undercarriages, bolted joints, etc., for the elimination of overhanging and eccentricity;

d) all aggregate/units, which create excessive noise as a result

of vortex formation or exhaust of air and gases (fans, blowers, pneumatic ejectors, internal combustion engines, etc.) to supply with special silencers with the outlet of the exhaust gas or air into ventilation systems or special boxes;

e) during the assembly of ventilation systems to observe all requirements, provided for in Section 6 of "measure for a reduction in the production noise in the effective shops";

f) in the places of a change in the direction of conduit/manifold to make the smooth rotations (during a change in the section/cut expansion angle must be not above 8-12° and welds must be without projections and projecting edges).

In the avoidance of the growth/build-up, not substantiated by the need for production noise, one should periodically reexamine existing technology:

a) noisy technological processes to replace noiseless (forging and stamping - by pressure, straightening/trimming - by rolling, riveting - by electric welding, pneumatic riveter - hydraulic, impact - press, nail-making machine - nail presses and so forth);

b) employ new types of technological working: electric-spark, anode-mechanical, chemical, ultrasonic, thermal, and so forth;

- c) to select least noisy equipment and instrument;
- d) to develop/process technical requirements by the new types of automatic or machinery and instrument;
- e) to develop/process the special sound-deadening attachments, creating the stability of parts during working and reliable attachment on machine tool or bench, that eliminate sound formation.

TECHNICAL SPECIFICATIONS OF THE PLANNING OF NOISY PRODUCTIONS.

1. All productions and shops must be classed according to loudness level (harmfulness).

The permissible loudness level of noise of outside production must not exceed 50 dB by day and 40 dB at night.

2. All enterprises and shops where is exceeded permissible loudness level, must be arrange/located in areas or places, which make it possible to observe established/installed sanitary zone of protection (breakage) from habitable structures and at noise productions and shops (Fig. 45).

Page 68.

3. Productions or settings up, which create intense noise above 130 dB and having free exhaust, must be arrange/located outside urban feature, at a distance of several kilometers (according to calculation) from nearest residential area from leeward relative to prevailing winds of side.

4. Noisy shops or productions (nailmaking, rock-breaking, etc.) must be concentrated in one place and be arrange/located in territory of plant from lee side (Fig. 46).

5. Structures of noisy production shops must be placed by end-type facade or at an angle not more than 30° to other shops.

6. Noisy shops or productions must be encircled by greenery (see Fig. 46).

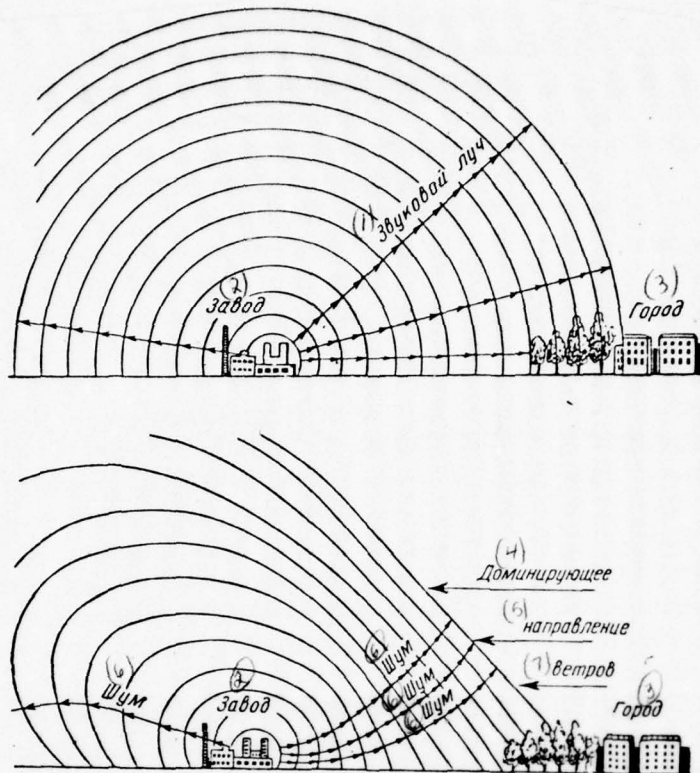
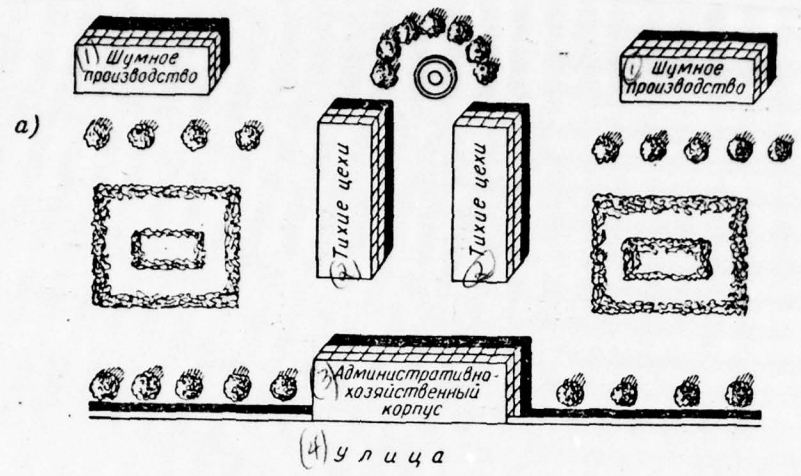

Fig. 45. Circuit of the arrangement of plant of outside city.

Key: (1). Sonic ray/beam. (2). Plant. (3). City. (4). Prevailing.
 (5). direction. (6). Noise. (7). Winds.

Page 69.



б)

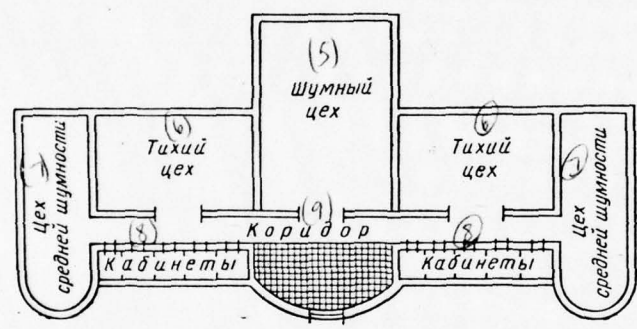

в)

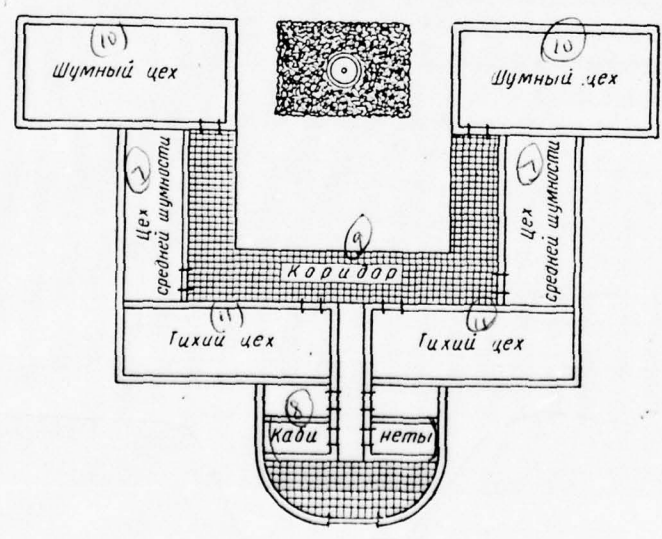

Fig. 46.

Fig. 45. In-plant planning of noisy productions. a, c) correct planning; b) incorrect planning.

Key: (1) - Noisy production. (2) - Calm shops. (3) - Administrative-economic housing. (4) - Street. (5) - Noisy shop. (6) - Technical shop. (7) - Shop of average noisiness. (8) - Offices. (9) - Corridor. (10) - Noisy shop. (11) - Calm shop.

Page 70.

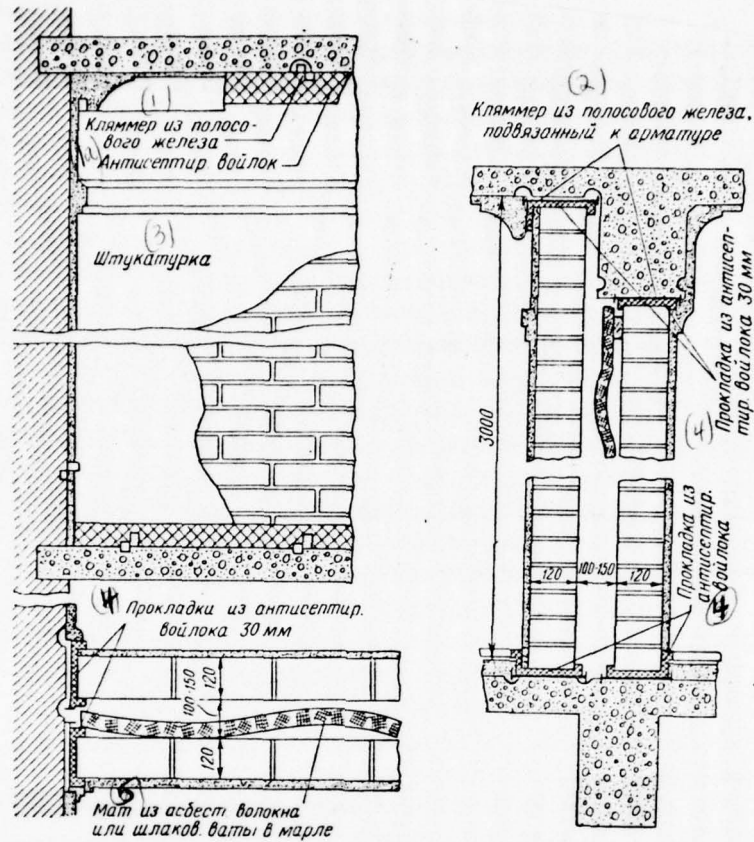

Fig. 47. Double partition/baffle with the layer of air and sound-absorbing material.

Key: (1). Clinch rivet from strip iron. (1A). Felt antisepticization. felt. (2). Clinch rivet from strip iron, tied up to fittings. (3). Plastering. (4). Packing of antisepticization of felt. (5). Matte finish from asbestos. filament or the slags. of cotton in gauze.

Page 71.

7. Structural/design parts of noisy shops and productions must be design/projected with thickened, heterogeneous multilayer walls, which have air and attenuating layers, winding channels, built-in resonance sound absorbers, sonic filters and so forth (Fig. 47 and 48).

8. Must be provided for internal of facing of walls by acoustic plastering on concrete or felt or by special acoustic plate/slabs from gypsum-asbestos or slag concrete.

9. Structural/design couplings of junctions of walls, weeding, partition/baffles must be provided for with vibration-isolating and sound-absorbing packing (Fig. 49, 50, 51, and 52).

10. Overlaps must be provided for weighted multilayer or special (floating) construction (see Fig. 51).

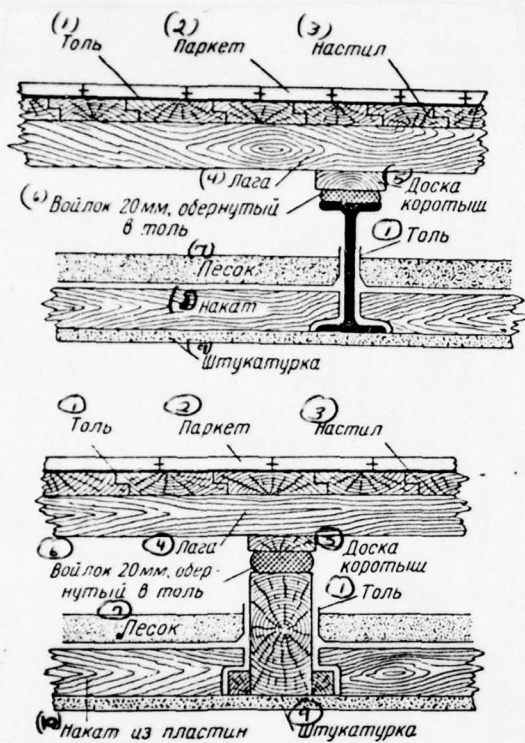
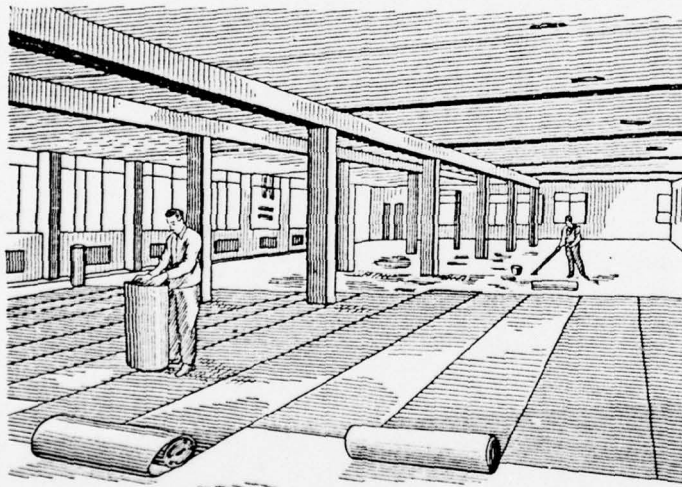
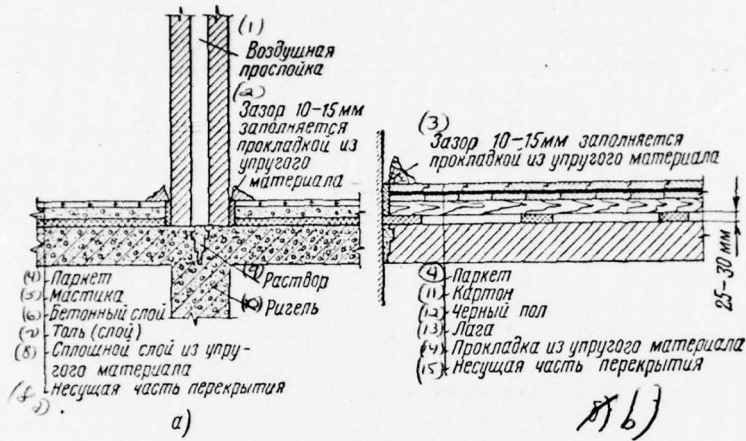

Fig. 48. Arrangement/permutation of the cushions in overlaps.

Key: (1). Roofing. (2). Parquet. (3). Flooring. (4). Log. (5). Panel bolster. (6). Felt 20 mm, put in order into mole. (7). Sand. (8). Counterrecoil. (9). Plastering. (10). Counterrecoil from plates.

Fig. 49. Floating enclosure/protections.

Key: (1). felt. (2). felt sex/floor. (3). Rabitz wire netting. (4). It is reinforced. detonation. (5). Springs. (6). Plastering. (7). vertical constructions. (8). Thermo-Izol. (9). Spring. (10). Cement filling. (11). Metals the logs of spring. (12). Thermo-insulation/insulating filling. (13). Channel bar. (14). Holders. (15). Spring. (16). Channel bar. (17). Construction of spring. (18). holder. (19). Load. (20). Plate/slab from slag wool. (21). Plinth. (22). Working diagram of spring suspension. (23). Black/ferrous sex/floor. (24). Pure/clean sex/floor. (25). felt. (26). Pure/clean sex/floor. (27). Pergamyn. (28). Thermo-Izol. (29). Black/ferrous sex/floor. (30). Cement filling. (31). Bitumen is pergamyn. (32). Thermal insulation. (33). Brace. (34). Logs cement filling. (35). Parts of the packing of the floating sex/floor.



вс)

Fig. 50. Construction of those who float weeding. a) on continuous elastic support, b) on logs with the cushions, c) the sound-proofing

packing.

Key: (1). Air layer. (2). gap 10-15 mm is filled with packing of elastic material. (3). Clearance 10-15 mm is filled with packing of elastic material. (4). Parquet. (5). Mastic. (6). Concrete layer. (7). Roofing (layer). (8). dense layer from elastic material. (8a). The backbone of the overlap. (9). Solution/opening. (10). Cross bar. (11). Cardboard. (12). Black/ferrous sex/floor. (13). Log. (14). Packing of elastic material. (15). The backbone of the overlap.

Page 74.

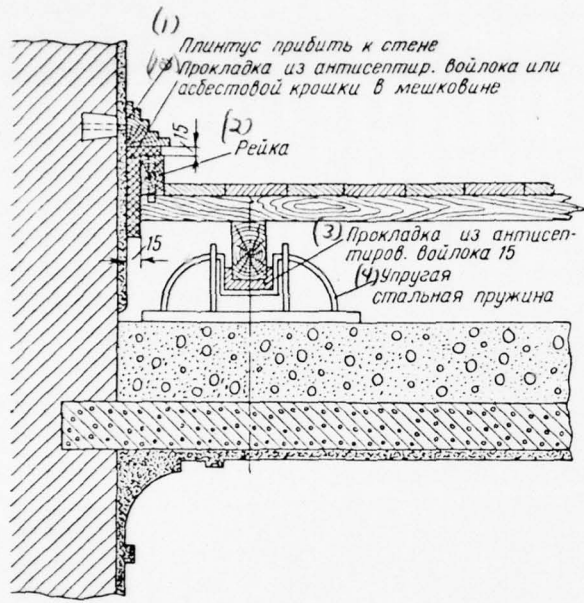

Fig. 51. Part of contiguity to the wall of the floating overlap.

Key: (1). Plinth drive against wall. (1A). Packing of antisepticized felt or asbestos grit in sacking. (2). Rack. (3). Packing of antisepticized felt 15. (4). Elastic steel spring.

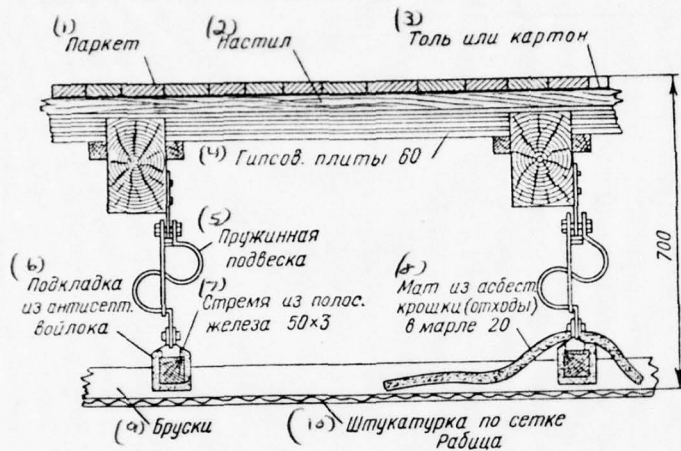

Fig. 52. Suspension ceiling during spring suspensions.

Key: (1). Parquet. (2). Flooring. (3). Roofing or cardboard. (4). Gypsums. of plate/slab 60. (5). Spring suspension. (6). Block/backing from the anti-septa. of felt. (7). Striving from the bands. of iron of 50 X 3. (8). Matte finish from asbestos grit (departure/withdrawals) in gauze 20. (9). Bars. (10). Plastering on the Rabits wire netting.

Page 75,

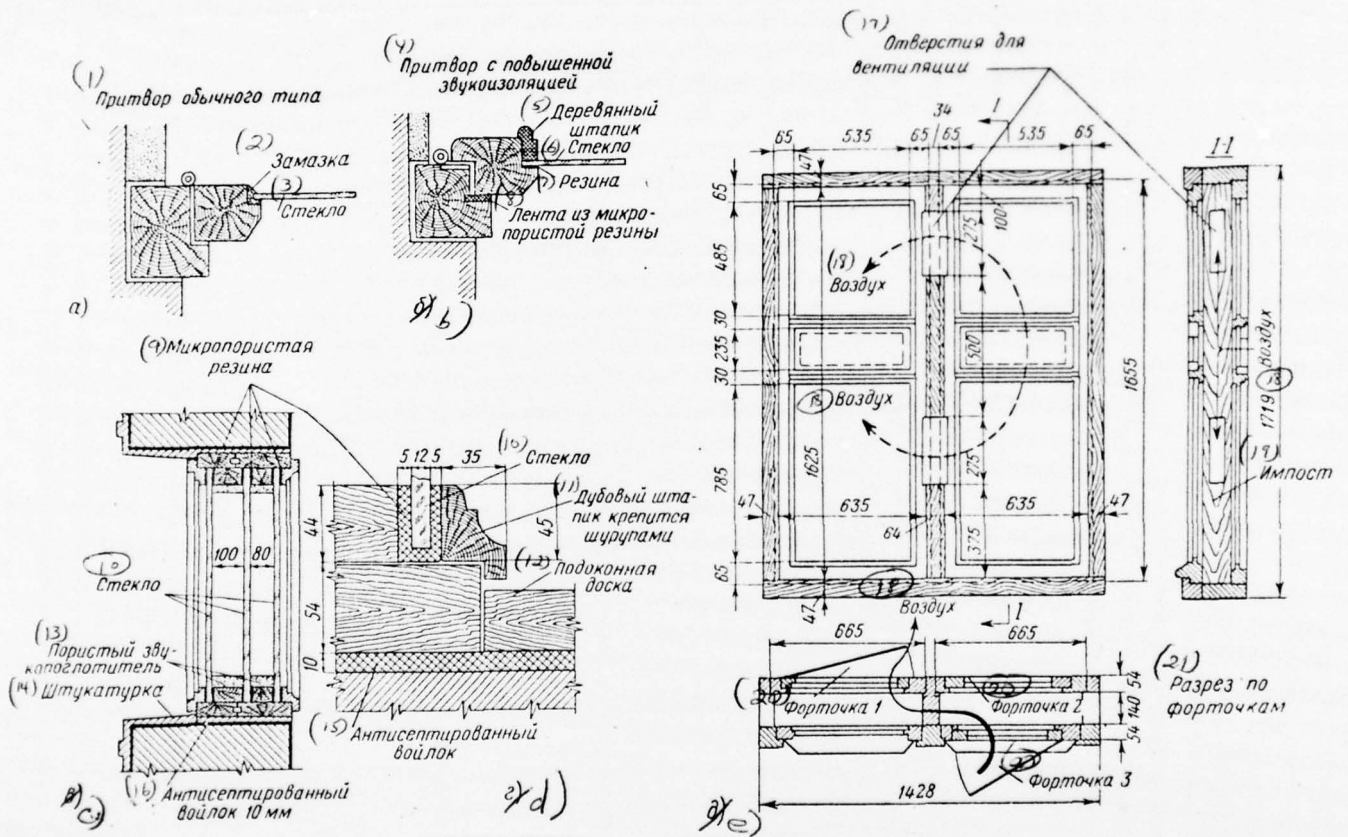

Fig. 53. Window with increased insulation/isolation. a and b) locking, open/disclosed windows, c) nonopen/disclosed inspection windows with high soundproofing, d) the fastening of glass, e) the open/disclosed noise-reducing construction.

Key: (1). Normal-type locking. (2). Cement. (3). Glass. (4). Locking with the increased soundproofing. (5). Wooden molding/bar. (6). Glass. (7). Rubber. (8). Film/strip from microporous rubber. (9). Microporous rubber. (10). Glasses. (11). Oak molding/bar is fastened with wood screws. (12). Window stool panel. (13). Porous sound absorber. (14). Plastering. (15). Disinfected felt. (16). Disinfected felt 10 mm. (17). Holes for ventilation. (18). Air. (19). Impost. (20). Window (21). Cut/section on forms.

Page 76.

11. Quantity of apertures in noisy shops must be strictly limitedly:

a) light apertures must be provided for with multilayer glazing (air gaps) and insulation/isolation of glass from material of frame and, consequently, also from walls (Fig. 53);

b) for door apertures must be provided for dense massive doors with packing within hair felt (Fig. 54) or with hinged/reversible plate/bar for closing of slot between sex/floor and door in the absence of threshold (Fig. 55).

12. Packing of sanitary-engineering equipment and communications of shops (water-conducting, heating or sewers, assembly of lighting system, radio, etc.) must be fulfilled with pressurized/sealed framing of holes according to entire thickness of walls (see Fig. 35).

13. Construction projects must be confirmed in division of hygiene of work of Ministry of Public Health of USSR in accordance with recommendations of institute of hygiene of work and occupational diseases AMS [Academy of Medical Sciences] of USSR.

14. Construction work must be fulfilled in strict conformity with project.

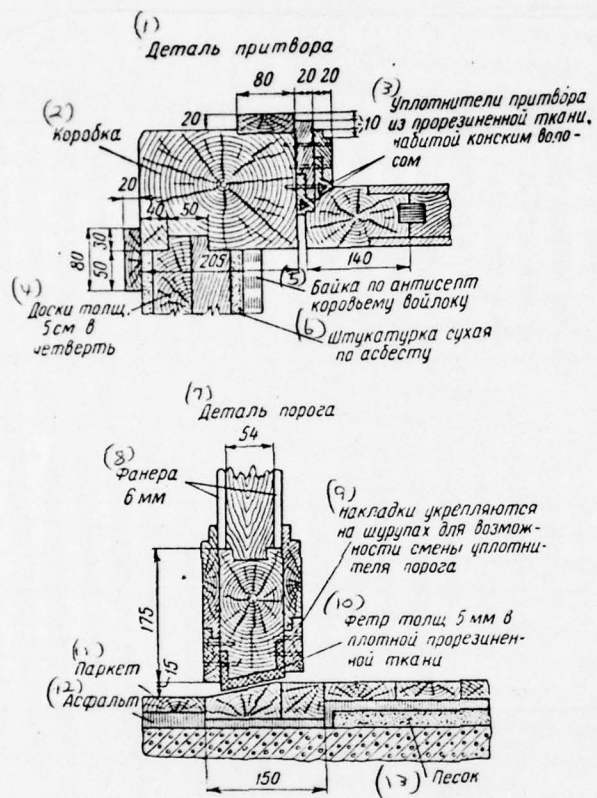

Fig. 54. Door with the condensed locking.

Key: (1). Part of locking. (2)- shell. (3). Sealers of locking from the rubberized fabric, packed with horse hair. (4). Panels of thicknesses 5 cm into fourth. (5). Flannelette on of anti-septa

bovine felt. (6). Plastering is dry on asbestos. (7). Part of threshold. (8). Plywood 6 mm. (9). Cover plates are fastened on wood screws for the possibility of the exchange of the sealer of threshold. (10). Felt of thicknesses 5 mm in the dense rubberized fabric. (11). Parquet. (12). Asphalt. (13). Sand.

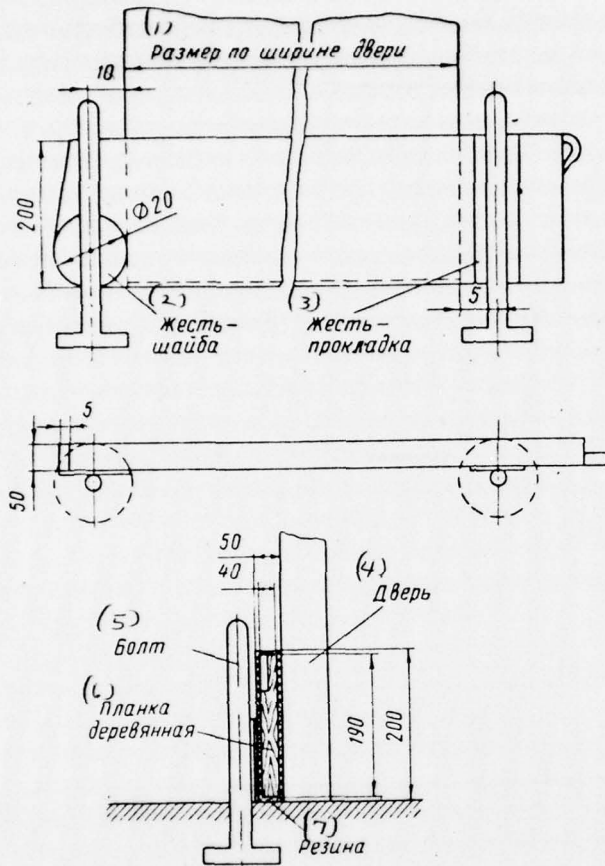

Fig. 55. The flap for a door without threshold.

Key: (1). Size/dimension in the width of door. (2). rigid washer.
 (3). rigid lining. (4). Door. (5). Bolt. (6). Planck is wooden. (7).
 Rubber.

Page 78.

REFERENCES.

Acoustic materials and their application/use, Stroyizdat, 1946.

S. P. Alekseyev, S. I. Vorobyev and V. L. Zharinov.
Soundproofing in building, Stroyizdat, 1949.

M. D. Genkin. Ways of a reduction in the noise of gears, the
"herald of machine-building", 1952, No 5-7.

A. Kauffmann and U. Schmidt. Sound suppressors of automobile
engines, ONTI, 1936.

T. A. Orlova. Noise and fight with it in production, the
institute of the sanitary education of the Ministry of Public Health
of the USSR, 1957.

S. N. Rzhevkin. Resonance sound absorption, about the
possibility of obtaining the large coefficients of sound absorption

DOC = 7723¹⁶407

PAGE ~~20~~ 184

with the aid of the system of resonators, the PAS of the USSR, Vol.
XVIII, 1938, NO 1.

I. I. Slavin. Production noise and fight with it, Profizdat,
1955.

DISTRIBUTION LIST

DISTRIBUTION DIRECT TO RECIPIENT

ORGANIZATION	MICROFICHE	ORGANIZATION	MICROFICHE
A205 DMATC	1	E053 AF/INAKA	1
A210 DMAAC	2	E017 AF/ RDXTR-W	1
B344 DIA/RDS-3C	8	E404 AEDC	1
C043 USAMIA	1	E408 AFWL	1
C509 BALLISTIC RES LABS	1	E410 ADTC	1
C510 AIR MOBILITY R&D LAB/FIO	1	E413 ESD	2
C513 PICATINNY ARSENAL	1	FTD	
C535 AVIATION SYS COMD	1	CCN	1
		ETID	3
C591 FSTC	5	NIA/PHS	1
C619 MIA REDSTONE	1	NICD	5
D008 NISC	1		
H300 USAICE (USAREUR)	1		
P005 ERDA	1		
P055 CIA/CRS/ADD/SD	1		
NAVORDSTA (50L)	1		
NASA/KSI	1		
AFIT/LD	1		