

AD-A051 967

AIRESEARCH MFG CO OF ARIZONA PHOENIX
EVALUATION OF A PRESSURIZED AIR START SYSTEM FOR ADVANCED ARMY --ETC(U)
NOV 77 J A RHODEN
41-1810A

F/G 21/5

DAAJ02-77-C-0007

NL

UNCLASSIFIED

USAAMRDL-TR-77-46

1 OF 2
AD
A051 967



AD A 051967

USAAMRDL-TR-77-46

121
54



**EVALUATION OF A PRESSURIZED AIR START SYSTEM
FOR ADVANCED ARMY HELICOPTERS**

AiResearch Manufacturing Company of Arizona
402 S. 36th Street
Phoenix, Arizona 85034

DDC FILE COPY

November 1977

Final Report

DDC
MAR 28 1978
F

Approved for public release;
distribution unlimited.

Prepared for
APPLIED TECHNOLOGY LABORATORY
U. S. ARMY RESEARCH AND TECHNOLOGY LABORATORIES (AVRADCOM)
Fort Eustis, Va. 23604

APPLIED TECHNOLOGY LABORATORY POSITION STATEMENT

This report provides a reasonable insight into the advantages and disadvantages of the PASS if installed in a single- or twin-engine powered helicopter. Drawings that describe the PASS components are included to give the reader a better understanding of the system. Life-Cycle Cost data has been generated and should be used with caution while being careful to define the anticipated Aircraft Usage Rate of Flight hours per month. Data is included for usage rates of 30 to 120 hours per month for all systems considered.

Mr. Paul Chesser of the Propulsion Technical Area, Technology Applications Division, served as Project Engineer for this effort.

DISCLAIMERS

The findings in this report are not to be construed as an official Department of the Army position unless so designated by other authorized documents.

When Government drawings, specifications, or other data are used for any purpose other than in connection with a definitely related Government procurement operation, the United States Government thereby incurs no responsibility nor any obligation whatsoever; and the fact that the Government may have formulated, furnished, or in any way supplied the said drawings, specifications, or other data is not to be regarded by implication or otherwise as in any manner licensing the holder or any other person or corporation, or conveying any rights or permission, to manufacture, use, or sell any patented invention that may in any way be related thereto.

Trade names cited in this report do not constitute an official endorsement or approval of the use of such commercial hardware or software.

DISPOSITION INSTRUCTIONS

Destroy this report when no longer needed. Do not return it to the originator.

UNCLASSIFIED

SECURITY CLASSIFICATION OF THIS PAGE (When Data Entered)

| 18. REPORT DOCUMENTATION PAGE | | READ INSTRUCTIONS BEFORE COMPLETING FORM | |
|--|---|--|---|
| 1. REPORT NUMBER USAAMRDL TR-77-46V | 2. GOVT ACCESSION NO. | 3. RECIPIENT'S CATALOG NUMBER | 9. TYPE OF REPORT & PERIOD COVERED Final Technical Report |
| 6. TITLE (and Subtitle) EVALUATION OF A PRESSURIZED AIR START SYSTEM FOR ADVANCED ARMY HELICOPTERS | | 10. PERFORMING ORG. REPORT NUMBER 41-1816A | 11. CONTRACT OR GRANT NUMBER (if any) DAAJ02-77-C-0007 new |
| 7. AUTHOR(s) J. A. Rhoden | 12. CONTROLLING OFFICE NAME AND ADDRESS Applied Technology Laboratory Research and Technology Laboratories (AVRADCOM), FORT EUSTIS, VIRGINIA 23604 | 13. PROGRAM ELEMENT, PROJECT, TASK AREA & WORK UNIT NUMBER 62209A IL262209AH76 | 14. REPORT DATE Nov 1977 |
| 14. MONITORING AGENCY NAME & ADDRESS (if different from Controlling Office) | 15. DISTRIBUTION STATEMENT (of this Report) Approved for public release; distribution unlimited. | 16. DISTRIBUTION STATEMENT (of the abstract entered in Block 20, if different from Report) | 17. SUPPLEMENTARY NOTES |
| 19. KEY WORDS (Continue on reverse side if necessary and identify by block number) PRESSURIZED AIR START SYSTEM ADVANCED ARMY HELICOPTER STUDY PROGRAM | | 15a. DECLASSIFICATION/DOWNGRADING SCHEDULE Unclassified | |
| 20. ABSTRACT (Continue on reverse side if necessary and identify by block number) This report presents the results of an evaluation of a pressurized air start system (PASS) for advanced Army helicopters. PASS is a new concept for starting gas turbine propulsion engines that currently use electric starters in conjunction with nickel-cadmium batteries. PASS is a stored energy start system using air as the working fluid. In addition to starting the engine by pressurized air, the engine can be started using pneumatic ground carts or bleed air from another engine. | | | |

DDC
APPROVED
MAR 28 1978
F

DD FORM 1473 JAN 73

EDITION OF 1 NOV 65 IS OBSOLETE

UNCLASSIFIED

SECURITY CLASSIFICATION OF THIS PAGE (When Data Entered)

404 796

self

UNCLASSIFIED

SECURITY CLASSIFICATION OF THIS PAGE (When Data Entered)

Block 20 (contd)

The study included a design evaluation of a PASS for both single- and twin-engine helicopters. In addition, a comparison of a PASS and an equivalent electric start system was made on the basis of performance, weight, reliability, maintainability, vulnerability, and life-cycle cost. The logistics of operating the PASS using current and planned ground support equipment was studied.

The results of the comparison indicated that PASS offers the following improvements over electric starting:

- o Engine start times can be reduced significantly;
- o System weight is lower;
- o Maintenance requirements can be reduced;
- o Reliability is improved significantly; and
- o Life-cycle cost can be reduced 30 to 40 percent ↑

| | |
|-------------------------------------|---|
| ACCESSION for | |
| NTIS | Write Section <input checked="" type="checkbox"/> |
| DDC | B. Section <input type="checkbox"/> |
| UNANNOUNCED | |
| JUSTIFICATION | |
| BY | |
| DISTRIBUTION/AVAILABILITY STATEMENT | |
| Date | |
| A | |

UNCLASSIFIED

SECURITY CLASSIFICATION OF THIS PAGE (When Data Entered)

SUMMARY

This report presents the results of an evaluation of a Pressurized Air Start System (PASS) for advanced Army helicopters. PASS is a new concept for starting gas turbine propulsion engines that currently use electric starters in conjunction with nickel-cadmium batteries.

The Pressurized Air Start System includes an air turbine starter mounted on the engine, an air storage (pressure vessel) and control module, and a recharge compressor located remotely in the aircraft. The starting energy is stored in the pressure vessel. After the start has been made, the compressor uses bleed air from the main engine as the power source for recharging the pressure vessel.

In addition to starting from stored energy, the engine can be started using compressed air from a pneumatic ground cart or bleed air from the other engine in a twin-engine helicopter. The starter has both a high- and a low-pressure connection for operation with the various power sources.

The evaluation was conducted for both single- and twin-engine helicopters. The single-engine helicopter considered utilized the T700-GE-700 engine rated at 1543 shp. The twin-engine helicopter considered utilized the TSE1035 designed in response to the Army's solicitation for an 800-shp Advanced Technology Demonstrator Engine and is a typical advanced 800-shp engine for this study.

The study program included evaluation of the following tasks:

- Design
- Maintenance
- Reliability
- Life-Cycle Cost
- Logistics
- Vulnerability

A comparison was made of a PASS with an electric start system for each engine.

The results of the evaluation are summarized below:

Weight

| Engine | System weight (lb) | | Weight savings with PASS (lb) |
|--------------------|--------------------|----------------|-------------------------------|
| | PASS | Electric start | |
| Single T700-GE-700 | 157 | 238 | 81 |
| Twin TSE1035 | 128 | 147 | 19 |

Performance

| Engine | Time to accelerate to starter cutout speed (sec) | |
|-------------|--|----------------|
| | PASS | Electric start |
| T700-GE-700 | 8.8 | 25.7 |
| TSE1035 | 5.9 | 16.1 |

Note: Based on sea level -25°F static design conditions.

Maintenance

| Engine | Maintenance man-hours per 1000 flight hours | |
|-----------------------|--|----------------|
| | PASS | Electric start |
| Single T700-GE-700 | 12.91 | 33.14 |
| Twin TSE1035 | 13.72 | 16.73 |

Reliability

| Engine | Average system MTBF | |
|-----------------------|---------------------|----------------|
| | PASS | Electric start |
| Single T700-GE-700 | 564 | 37 |
| Twin TSE1035 | 478 | 94 |

Life-Cycle Cost

| Engine | 10-year life-cycle cost for 700 aircraft (millions of 1977 dollars) | |
|-----------------------|---|----------------|
| | PASS | Electric start |
| Single T700-GE-700 | 19.15 | 32.44 |
| Twin TSE1035 | 23.86 | 31.60 |

Vulnerability

| Engine | Total possible system area exposed to ballistic impact (sq in.) | |
|-----------------------|---|----------------|
| | PASS | Electric start |
| Single T700-GE-700 | 1285 | 558 |
| Twin TSE1035 | 1039 | 492 |

As shown, the PASS offers significant improvement over the electric start system in all of the parameters except vulnerability.

In addition to presenting the results of the study, Appendix A of this report presents a summary of the AiResearch company-sponsored PASS Research and Development Program. This program has been active since 1974 and has included the experimental development of components for an APU starting system as well as main propulsion engines.

PREFACE

This report was prepared by AiResearch Manufacturing Company of Arizona. The work was accomplished under Contract DAAJ02-77-C-0007 with the Eustis Directorate, U.S. Army Air Mobility Research and Development Laboratory, * Ft. Eustis, Virginia. Mr. J. A. Rhoden was the principal investigator for the program for AiResearch. The Contracting Officer's Technical Representative (COTR) was Mr. Paul Chesser.

The author wishes to acknowledge contributions made to this program by the many individuals at AiResearch, particularly Mr. R. H. Larson.

The author also wishes to acknowledge the contribution of data from the following companies: Bell Helicopter, Division of Textron; Vertol Division, Boeing Company; Sikorsky Aircraft; General Electric Company, Lynn, Massachusetts; MC Division of Kelsey-Hayes; Valcor Engineering Corporation; Gulton Industries/Engineered Magnetics Division; and Structural Composites Industries, Inc.

*On 1 September 1977, the Eustis Directorate, U.S. Army Air Mobility Research and Development Laboratory was redesignated the Applied Technology Laboratory, U.S. Army Research and Technology Laboratories (AVRADCOM).

TABLE OF CONTENTS

| | PAGE |
|---|------|
| SUMMARY | 3 |
| PREFACE | 7 |
| INTRODUCTION | 16 |
| DISCUSSION OF STUDY TASKS | 19 |
| TASK I - DESIGN | 19 |
| SYSTEM OPERATION | 22 |
| PRESSURE VESSEL SIZING | 24 |
| AIR TURBINE STARTER PERFORMANCE CHARACTERISTICS | 30 |
| DESCRIPTION OF PASS COMPONENTS | 35 |
| PASS COMPONENT WEIGHTS | 55 |
| PASS INSTALLATION CHARACTERISTICS | 55 |
| PASS COMPARISON WITH ELECTRIC START SYSTEM | 65 |
| TASK II - MAINTENANCE | 77 |
| TASK III - RELIABILITY | 82 |
| TASK IV - LIFE-CYCLE COST INVESTIGATION | 89 |
| LIFE-CYCLE COST EQUATIONS AND VARIABLES | 95 |
| TASK V - LOGISTICS | 102 |
| PNEUMATIC GROUND CARTS | 102 |
| BACKUP RECHARGE EQUIPMENT | 103 |
| GROUND COMPRESSOR UNITS | 108 |
| PORTABLE GAS SERVICING UNITS | 111 |
| HAND CRANK WITH ON-BOARD COMPRESSOR | 112 |
| TASK VI - VULNERABILITY | 115 |
| CONCLUSIONS | 120 |
| RECOMMENDATIONS | 122 |
| APPENDIXES | |
| A SUMMARY OF AIRESEARCH COMPANY-SPONSORED PASS RESEARCH AND DEVELOPMENT PROGRAM | 123 |
| B DRAWINGS | 163 |

Preceding Page BLANK -

LIST OF ILLUSTRATIONS

| <u>FIGURE</u> | | <u>PAGE</u> |
|---------------|--|-------------|
| 1 | PASS block diagram | 17 |
| 2 | PASS system schematic (single-engine) . . . | 20 |
| 3 | PASS system schematic (twin-engine) | 21 |
| 4 | PASS starting data for General Electric T700-GE-700 engine | 26 |
| 5 | PASS starting data for TSE1035 engine . . . | 27 |
| 6 | Starting torque and speed requirements, sea level static conditions, T700-GE-700 engine | 28 |
| 7 | Estimated starting characteristics, TSE1035 engine | 29 |
| 8 | PASS starting characteristics, T700-GE-700 engine | 31 |
| 9 | PASS starting characteristics, TSE1035 engine | 32 |
| 10 | Air turbine starter Model ATS18-3 | 34 |
| 11 | Generalized performance of air turbine starter, Part 3505380 - high-pressure mode of operation | 36 |
| 12 | Generalized performance of air turbine starter, Part 3505380 - low-pressure mode of operation | 37 |
| 13 | Generalized performance of air turbine starter, Part 3505386 - high-pressure mode of operation | 38 |
| 14 | Generalized performance of air turbine starter, Part 3505386 - low-pressure mode of operation | 39 |
| 15 | Moisture removal system | 42 |
| 16 | Schematic of recharge compressor | 44 |
| 17 | Compressor bleed-air requirements | 46 |
| 18 | Compressor recharge characteristics, T700-GE-700 engine | 47 |

LIST OF ILLUSTRATIONS (CONTD)

| <u>FIGURE</u> | | <u>PAGE</u> |
|---------------|---|-------------|
| 19 | Compressor recharge characteristics, TSE1035 engine | 48 |
| 20 | Cross section of air turbine starter . . . | 50 |
| 21 | Airflow path - air turbine starter | 51 |
| 22 | Monopole pickup configuration | 53 |
| 23 | PASS system schematic (single-engine) . . . | 58 |
| 24 | PASS system schematic (twin-engine) | 59 |
| 25 | Single-engine PASS installation | 60 |
| 26 | Battery and conditioner dimensions | 64 |
| 27 | Electric start system - single-engine aircraft | 66 |
| 28 | Electric start system - twin-engine aircraft | 67 |
| 29 | Electric start analysis - T700-GE-700 engine | 68 |
| 30 | Generalized performance - Model GE 2CM272A1 electric starter | 70 |
| 31 | Discharge characteristics - 22-AH Ni-Cd battery | 71 |
| 32 | Electric start analysis - TSE1035 engine | 72 |
| 33 | Generalized performance - AiResearch Model 519802-4 electric starter | 73 |
| 34 | Life-cycle cost versus aircraft usage rate for single T700-GE-700 engine | 92 |
| 35 | Life-cycle cost versus aircraft usage rate for twin TSE1035 engines | 93 |
| 36 | Type A/M32A-60A ground power unit | 104 |
| 37 | Ground power unit, gas turbine powered . . . | 105 |
| 38 | PASS recharge characteristics with MIL-C-52037 compressor | 109 |

LIST OF ILLUSTRATIONS (CONTD)

| <u>FIGURE</u> | | <u>PAGE</u> |
|---------------|---|-------------|
| 39 | PASS recharge characteristics with MIL-C-52477 compressor | 110 |
| 40 | Estimated cranking capability, average man | 113 |
| 41 | Filament-wound pressure vessels after 0.30-caliber gunfire test | 117 |
| A-1 | Air vane starter operation | 131 |
| A-2 | Development test vane motor | 132 |
| A-3 | Exploded view of air vane starter | 133 |
| A-4 | Air vane starter rotor and vanes | 134 |
| A-5 | Schematic arrangement of pneumatic amplifier | 136 |
| A-6 | Pneumatic amplifier, pneumatically driven | 138 |
| A-7 | Flywheel test rig for air vane starter testing | 139 |
| A-8 | Model GTCP36-50 APU demonstrator test setup, pressurized air start system | 140 |
| A-9 | Air vane starter installed on Model GTCP36-50 APU | 141 |
| A-10 | Model JFS190 APU demonstrator test setup, pressurized air start system | 142 |
| A-11 | Model JFS190 APU demonstrator test setup, pressurized air start system | 143 |
| A-12 | Model JFS190 APU demonstrator test setup, pressurized air start system | 144 |
| A-13 | Candidate starter configuration | 147 |
| A-14 | Turbine and reduction gearing of starter Model ATSl8-3 | 149 |
| A-15 | Compressor drive options | 153 |
| A-16 | Schematic of PASS compressor | 155 |
| A-17 | Breadboard PASS compressor | 156 |
| A-18 | Weight comparison of cylindrical pressure vessels | 158 |

LIST OF ILLUSTRATIONS (CONCLUDED)

| <u>FIGURE</u> | | <u>PAGE</u> |
|---------------|--|-------------|
| A-19 | Schematic diagram of the PASS pressure regulator and shutoff valve | 160 |
| A-20 | Comparison of experimental bottle blowdown test data with isentropic expansion | 161 |
| A-21 | Blowdown through constant area orifice test setup | 162 |
| | | |
| B-1 | Primary pressure vessel/mainfold assembly (3400 in. ³) | 163 |
| B-2 | Reserve pressure vessel/manifold assembly (3400 in. ³) | 165 |
| B-3 | Solenoid shutoff valve | 167 |
| B-4 | Air turbine starter | 169 |
| B-5 | Starter control valve | 171 |
| B-6 | Recharge compressor | 173 |
| B-7 | Primary pressure vessel/manifold assembly (1000 in. ³) | 175 |
| B-8 | Reserve pressure vessel/manifold assembly (1000 in. ³) | 177 |
| B-9 | Solenoid shutoff valve | 179 |
| B-10 | Air turbine starter | 181 |

LIST OF TABLES

| <u>TABLE</u> | | <u>PAGE</u> |
|--------------|--|-------------|
| 1 | SUMMARY OF ENGINE STARTING CHARACTER- ISTICS | 33 |
| 2 | LIST OF PASS COMPONENT DRAWINGS | 40 |
| 3 | WEIGHT SUMMARY OF PRESSURIZED AIR START SYSTEM FOR THE T700-GE-700 ENGINE | 56 |
| 4 | WEIGHT SUMMARY OF PRESSURIZED AIR START SYSTEM FOR THE TSE1035 ENGINE | 57 |
| 5 | PNEUMATIC LINE LENGTHS AND SIZES FOR PASS INSTALLATION | 62 |
| 6 | PERFORMANCE COMPARISON PASS AND ELECTRIC START SYSTEM | 74 |
| 7 | WEIGHT SUMMARY OF PASS AND ELECTRIC START, SINGLE T700-GE-700 ENGINE | 75 |
| 8 | WEIGHT SUMMARY OF PASS AND ELECTRIC START, TWIN TSE1035 ENGINES | 76 |
| 9 | SCHEDULED MAINTENANCE OF PRESSURIZED AIR START SYSTEM | 78 |
| 10 | UNSCHEDULED MAINTENANCE OF PRESSURIZED AIR START SYSTEM | 79 |
| 11 | SCHEDULED MAINTENANCE OF ELECTRIC START SYSTEM | 80 |
| 12 | UNSCHEDULED MAINTENANCE OF ELECTRIC START SYSTEM | 80 |
| 13 | MAINTENANCE COMPARISON - PASS AND ELECTRIC START SYSTEM | 81 |
| 14 | RELIABILITY COMPARISON - PASS AND ELECTRIC START SYSTEM | 82 |
| 15 | PROJECTED RELIABILITY OF PRESSURIZED AIR START SYSTEM | 83 |
| 16 | PROJECTED RELIABILITY OF ELECTRIC START SYSTEM | 84 |
| 17 | FAILURE MODES AND EFFECTS ANALYSIS OF PRESSURIZED AIR START SYSTEM | 86 |

LIST OF TABLES (CONCLUDED)

| <u>TABLE</u> | | <u>PAGE</u> |
|--------------|--|-------------|
| 18 | LIFE-CYCLE COST COMPARISON | 89 |
| 19 | LIFE-CYCLE COST SUMMARY FOR 120 FLIGHT HOURS PER MONTH (1977 DOLLARS) | 90 |
| 20 | LIFE-CYCLE COST SUMMARY FOR 30 FLIGHT HOURS PER MONTH (1977 DOLLARS) | 91 |
| 21 | SUMMARY OF CONSTANTS USED IN LIFE-CYCLE COST ANALYSIS | 94 |
| 22 | QUALITATIVE COMPARISON OF ADDITIONAL LIFE- CYCLE COST PARAMETERS | 96 |
| 23 | DISPOSITION OF FAILED COMPONENTS OF ELECTRIC START SYSTEM | 99 |
| 24 | DISPOSITION OF FAILED COMPONENTS OF PRESSURIZED AIR START SYSTEM | 100 |
| 25 | BATTERY REPAIR COST DATA | 101 |
| 26 | SUMMARY OF PNEUMATIC GROUND CART STARTING ANALYSIS WITH T700-GE-700 ENGINE AND STARTER, PART 3505380 | 106 |
| 27 | SUMMARY OF PNEUMATIC GROUND CART STARTING ANALYSIS WITH TSE1035 ENGINE AND STARTER, PART 3505386 | 107 |
| 28 | PASS RECHARGE CAPABILITY WITH PORTABLE GAS SERVICING UNITS | 111 |
| 29 | BALLISTIC IMPACT ANALYSIS, PRESSURIZED AIR START SYSTEM | 116 |
| 30 | AREA EXPOSED TO BALLISTIC IMPACT COMPARISON | 119 |
| A-1 | PASS START MOTOR EVALUATION FOR APU'S . . . | 129 |
| A-2 | COMPARISON OF STARTER CHARACTERISTICS . . . | 148 |
| A-3 | RESULTS OF PERFORMANCE TESTING AIR TURBINE STARTER MODEL ATs18-3 MODIFIED FOR PARTIAL- ADMISSION | 151 |
| A-4 | PASS COMPRESSOR EVALUATION | 152 |

INTRODUCTION

The PASS concept is illustrated by the block diagram of Figure 1. The system uses an air starter mounted on the propulsion engine starter pad. This starter is similar to that currently in use on the Utility Tactical Transport Aircraft (UTTAS) and the Advanced Attack Helicopter (AAH). The power supply for the starter is contained in the air storage (pressure vessel) module. The control module regulates the air pressure to the starter and contains the necessary components for controlling the operation of the system. A piston compressor is used to recharge the pressure vessel after the engine has been started.

The study program described in this report was based on expanding an initial preliminary study conducted by AiResearch as a portion of a company-sponsored research and development program. The preliminary study included primarily weight and performance comparison with an electric start system. The more detailed evaluation described in this report includes:

- Design for both single- and twin-engine aircraft
- Maintenance
- Reliability
- Life-Cycle Cost
- Logistics
- Vulnerability

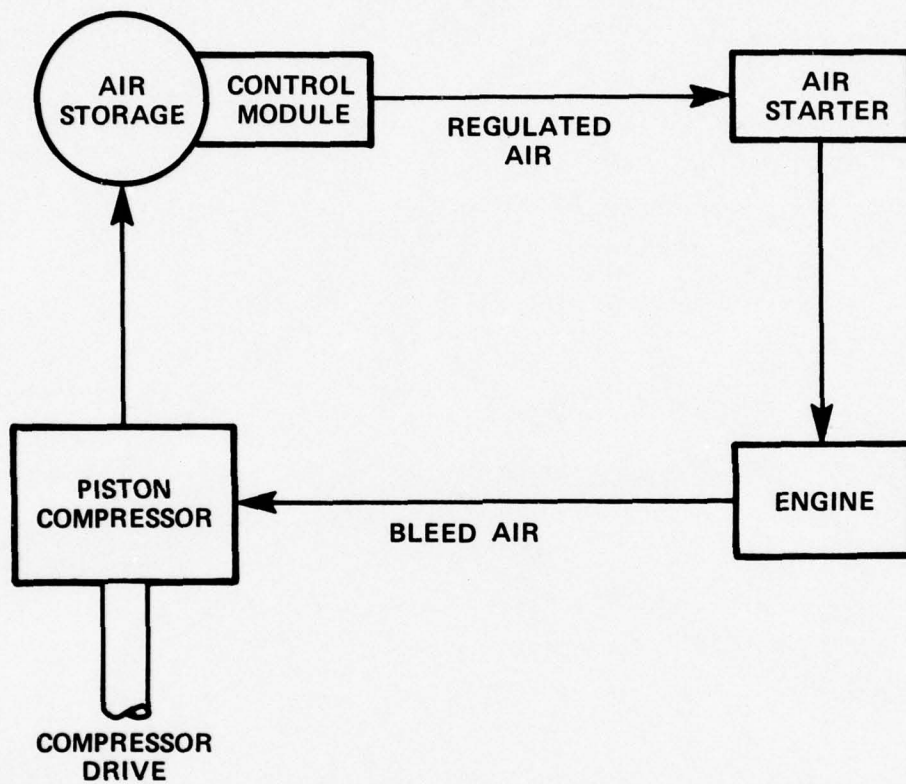
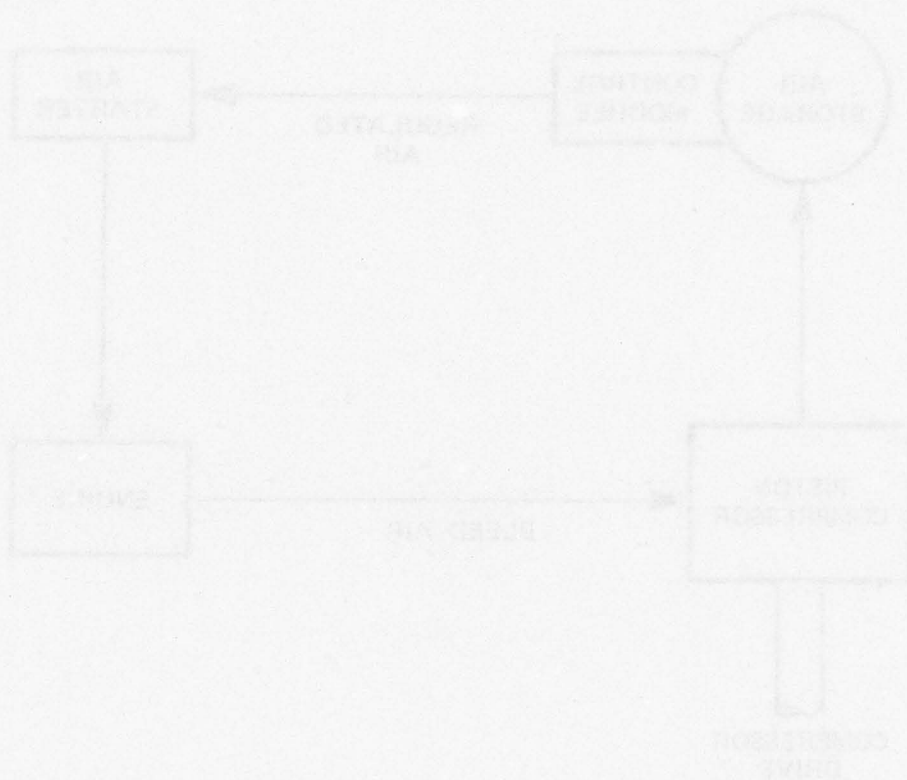

Figure 1. PASS block diagram.

In addition to presenting the results of these studies, a description of the activities conducted under the AiResearch company-sponsored research and development program is presented in Appendix A.



DISCUSSION OF STUDY TASKS

The results of an evaluation of the study program are presented in the following paragraphs. A discussion is presented for each of the study tasks defined in the USAAMDRL Statement of Work.

TASK I - DESIGN

A design study of the pressurized air start system for single- and twin-engine helicopter installations was conducted. The single-engine aircraft was based on the T700-GE-700 engine, and the twin-engine aircraft was based on an advanced 800-shp engine (AiResearch Model TSE1305). Although the AiResearch TSE1035 is not an existing engine, detailed aerodynamic and mechanical design studies of this engine have been conducted. The starting characteristics, applicable to this study, were estimated based on the thermodynamic unbalanced torque calculation and measured drag data from other similar AiResearch engines.

The PASS configurations selected for evaluation are shown in Figures 2 and 3, which show the single- and twin-engine systems, respectively. These configurations were established based on the results of previous studies conducted under the AiResearch company-sponsored PASS Research and Development Program. A summary of the company-sponsored program is presented in Appendix A.

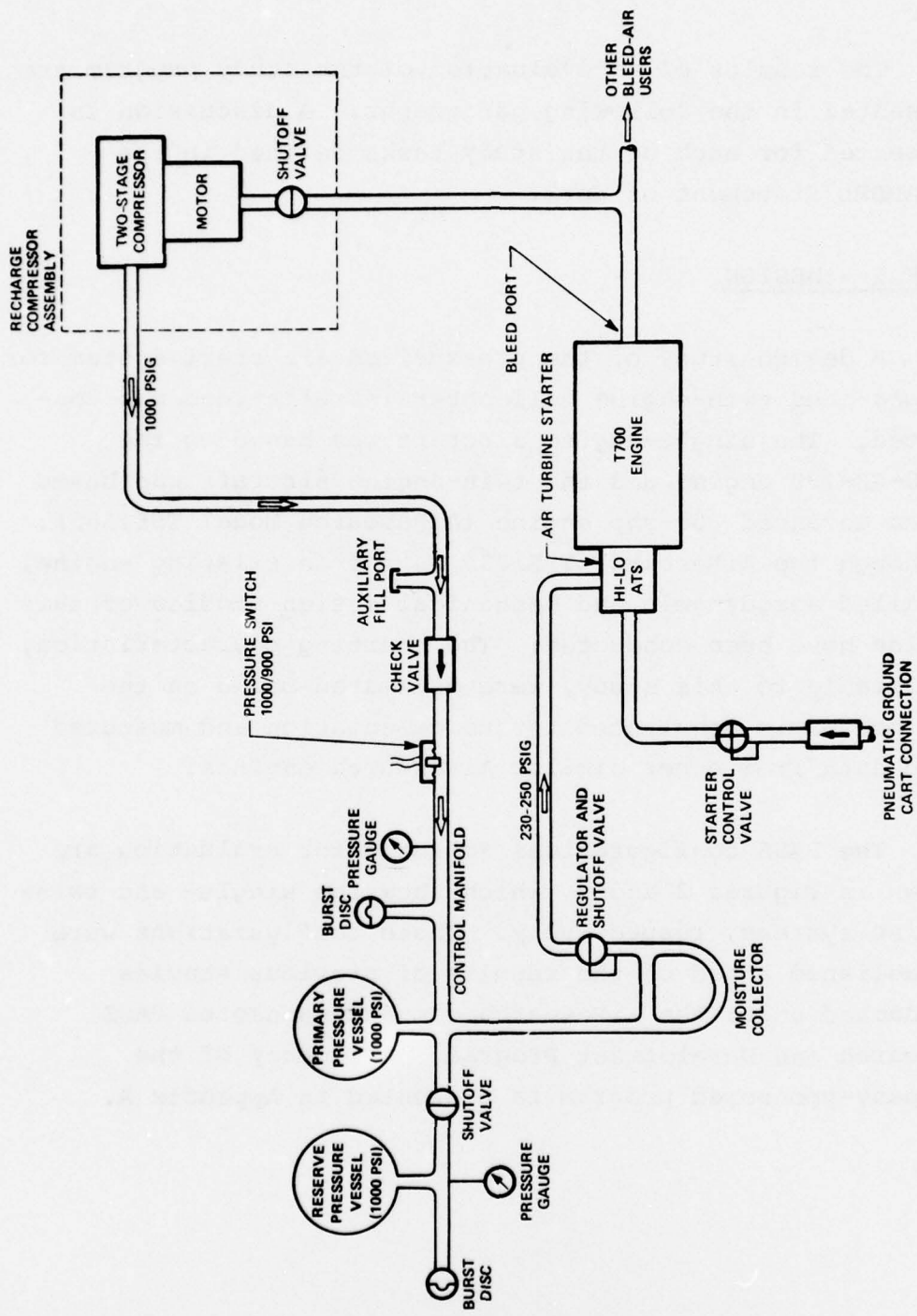

Figure 2. PASS system schematic (single-engine).

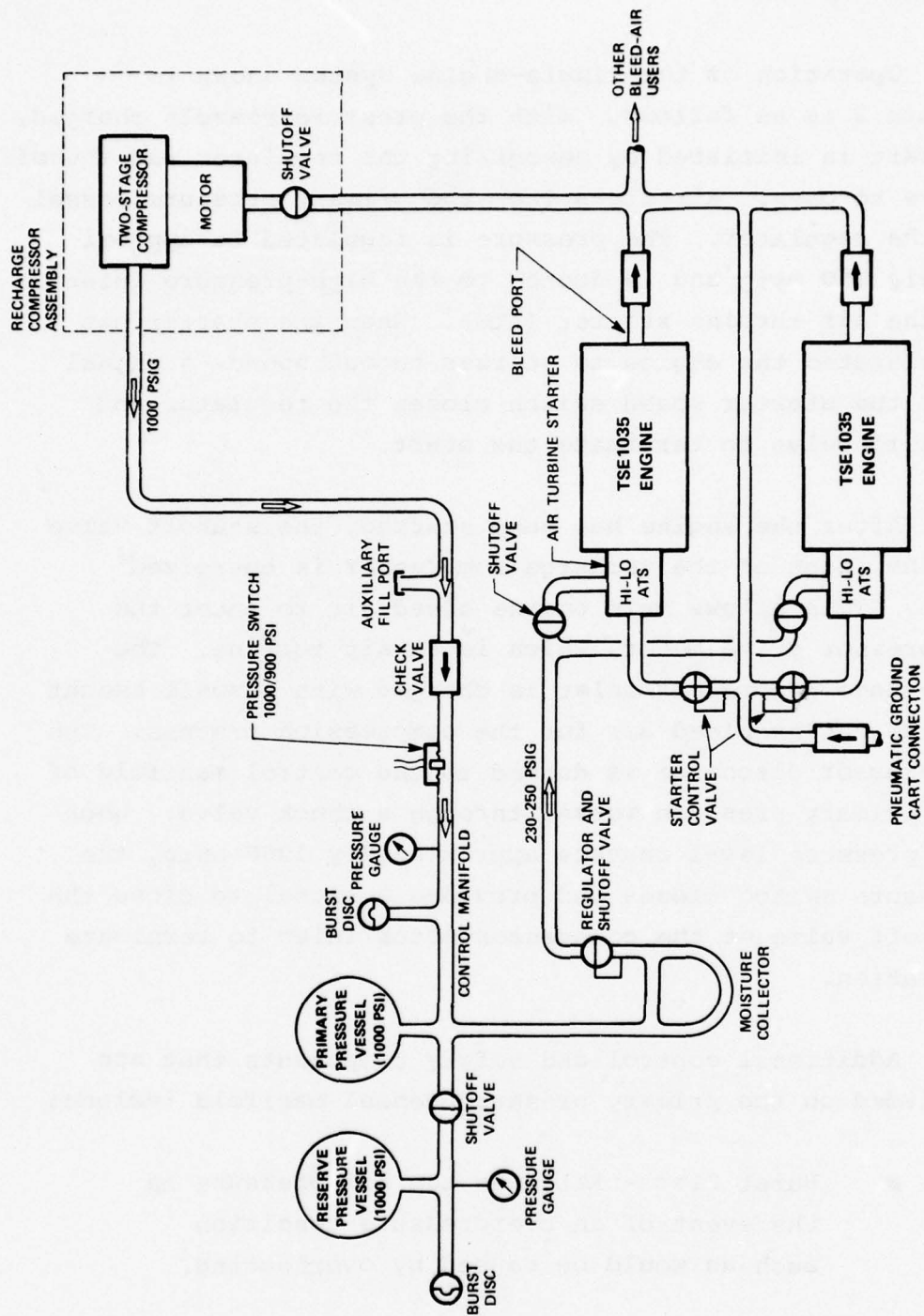

Figure 3. PASS system schematic (twin-engine).

SYSTEM OPERATION

Operation of the single-engine system shown in Figure 2 is as follows. With the pressure vessels charged, a start is initiated by energizing the regulator and shutoff valve to open. Air flows from the primary pressure vessel to the regulator. The pressure is regulated to approximately 250 psig and is ducted to the high-pressure inlet of the air turbine starter (ATS). When the starter has accelerated the engine to starter cutout speed, a signal from the starter speed switch closes the regulator and shutoff valve to terminate the start.

After the engine has been started, the shutoff valve at the inlet of the recharge compressor is energized open. This allows main engine bleed air to enter the compressor drive motor, which is an air turbine. The two-stage compressor inlet is charged with a small amount of the engine bleed air for the compression process. The compressor discharge is ducted to the control manifold of the primary pressure vessel through a check valve. When the pressure level reaches approximately 1000 psig, the pressure switch closes and provides a signal to close the shutoff valve at the compressor motor inlet to terminate operation.

Additional control and safety components that are included on the primary pressure vessel manifold include:

- Burst Disc - Relieves the air pressure in the event of an overpressure condition such as would be caused by overheating.

- Pressure Gauge - Allows monitoring system pressure for maintenance.
- Auxiliary Fill Port - A connection to attach a portable ground air compressor or gas servicing unit to pressurize the system in the event of leakage or maintenance action requiring servicing.
- Moisture Collector - A small reservoir to collect moisture and discharge it during the start cycle to prevent any accumulation that may freeze in low-temperature environments.

In addition to the primary pressure vessel, a reserve pressure vessel is attached to the primary vessel through a shutoff valve. This unit provides a redundant start capability to the system. This unit is normally isolated from the system by the shutoff valve and, in the event of leakage in the primary, the shutoff valve is opened to pressurize the system for a start. The reserve pressure can also be used simultaneously with the primary for operation at extreme low temperatures (below -25°F). The reserve pressure vessel also includes a pressure gauge and a burst disc.

In addition to using the PASS air supply for starting, the engine can be started using a low-pressure pneumatic ground cart. When the pneumatic ground cart is attached to the aircraft, air flows through the starter control

valve to the low-pressure inlet of the air turbine starter. In the event the ground cart pressure is too high, the starter control valve will regulate the starter inlet pressure (40 psig) to prevent applying excessive torque to the engine.

Operation of the twin-engine aircraft system (see Figure 3) is identical to the single-engine aircraft system except as follows: Select the engine to be started using the PASS air supply system and initiate start. After this engine has been started using the PASS, the other engine is started by cross-bleeding the operating engine to the low-pressure inlet of the starter. The starter control valve in this system controls both cross-bleed and pneumatic ground cart operation.

Since both air turbine starters are supplied from a common pressure supply in the high-pressure start mode, shutoff valves are included in the high-pressure line to select the appropriate starter.

PRESSURE VESSEL SIZING

The air storage requirements for starting the T700-GE-700 and TSE1035 engines were determined by using an AiResearch computer program that simulates the blowdown characteristics of the pressure vessel and regulator valve, the starter performance characteristics, and the engine starting characteristics. The pressure vessel sizing was based on a design requirement of providing two engine starts (one from each pressure vessel) at an

ambient temperature of -25°F at sea level ambient pressure. For the analysis, it was assumed that the pressure vessel was charged to 1000 psig at an ambient temperature of 59°F and then soaked to the -25°F condition.

The results of the pressure vessel sizing analysis are shown below:

| Engine | Required pressure vessel size for one start at sea level -25°F | Pressure vessel dimensions | |
|-------------|--|----------------------------|----------|
| | | Diameter | Length |
| T700-GE-700 | 3400 cu in. | 13.0 in. | 33.0 in. |
| TSE1035 | 1000 cu in. | 8.9 in. | 22.7 in. |

The effect of ambient temperature on pressure vessel sizing is shown in Figures 4 and 5 for the T700-GE-700 and TSE1035 engines, respectively. As shown in these figures, with the pressure vessels sized to provide two starts (one from each unit), the engines can be started below -65°F by using both pressure vessels simultaneously. This precludes any special winterization requirements for the system.

The engine starting characteristics used for this analysis are shown in Figures 6 and 7. The T700-GE-700 engine data was supplied to AiResearch by General Electric. The starting characteristics of the TSE1035 engine were estimated by AiResearch.

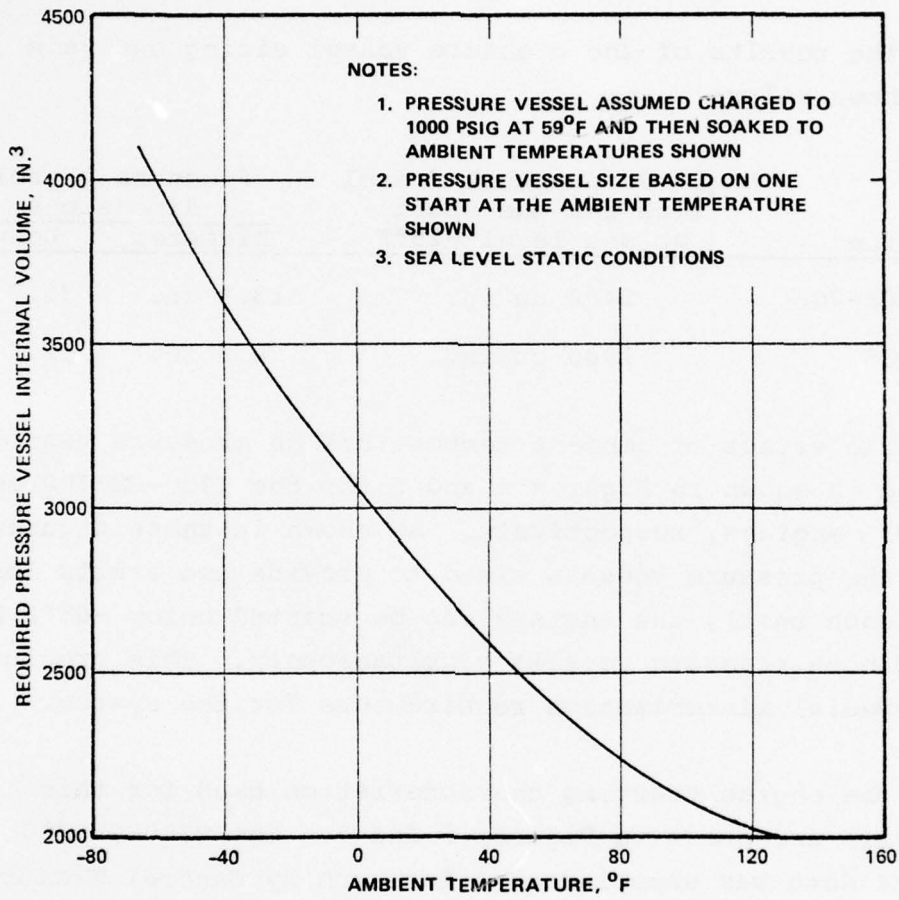

Figure 4. PASS starting data for General Electric T700-GE-700 engine.

NOTES:

1. PRESSURE VESSEL ASSUMED CHARGED TO 1000 PSIG AT 59°F AND THEN SOAKED TO AMBIENT TEMPERATURES SHOWN
2. PRESSURE VESSEL SIZE BASED ON ONE START AT THE AMBIENT TEMPERATURE SHOWN
3. SEA LEVEL STATIC CONDITIONS

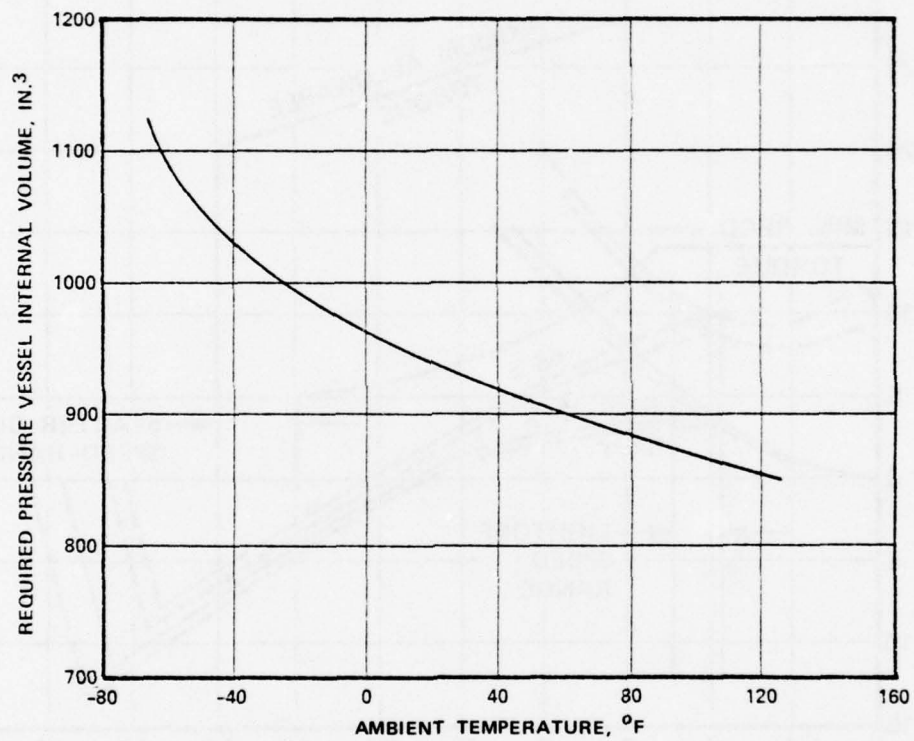

Figure 5. PASS starting data for TSE1035 engine.

- SEA LEVEL
- ENGINE INERTIA = 0.106 SLUG-FT²

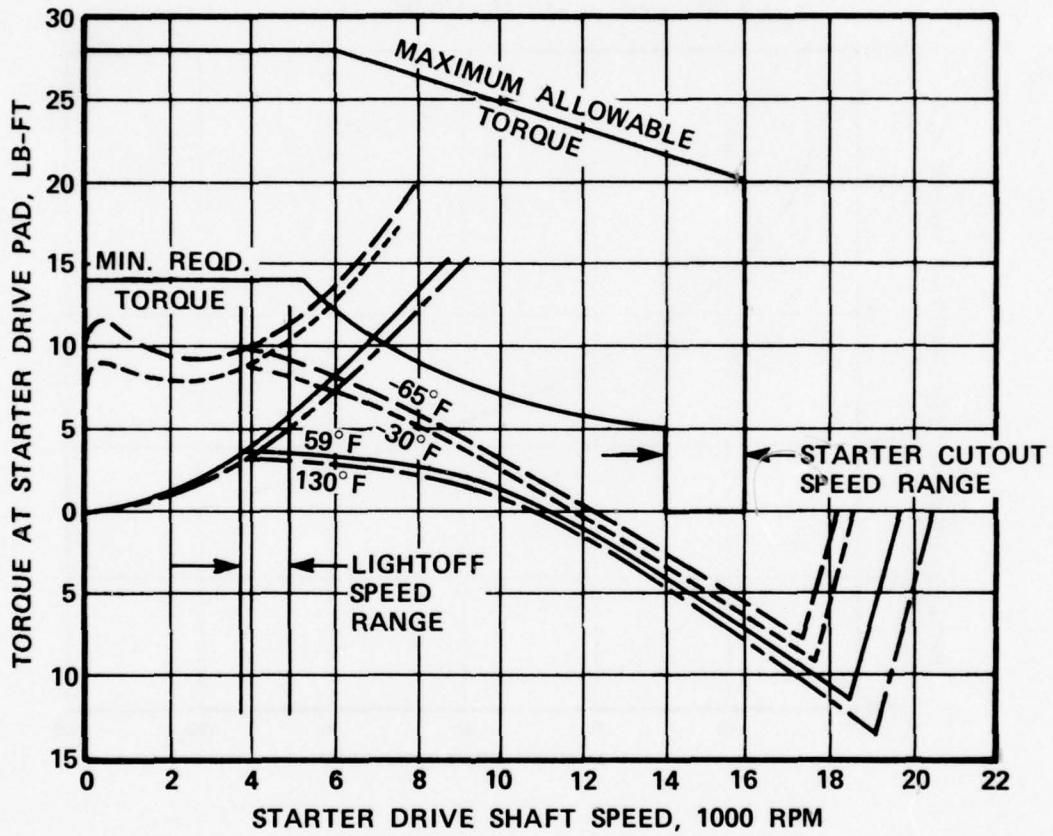

Figure 6. Starting torque and speed requirements, sea level static conditions, T700-GE-700 engine.

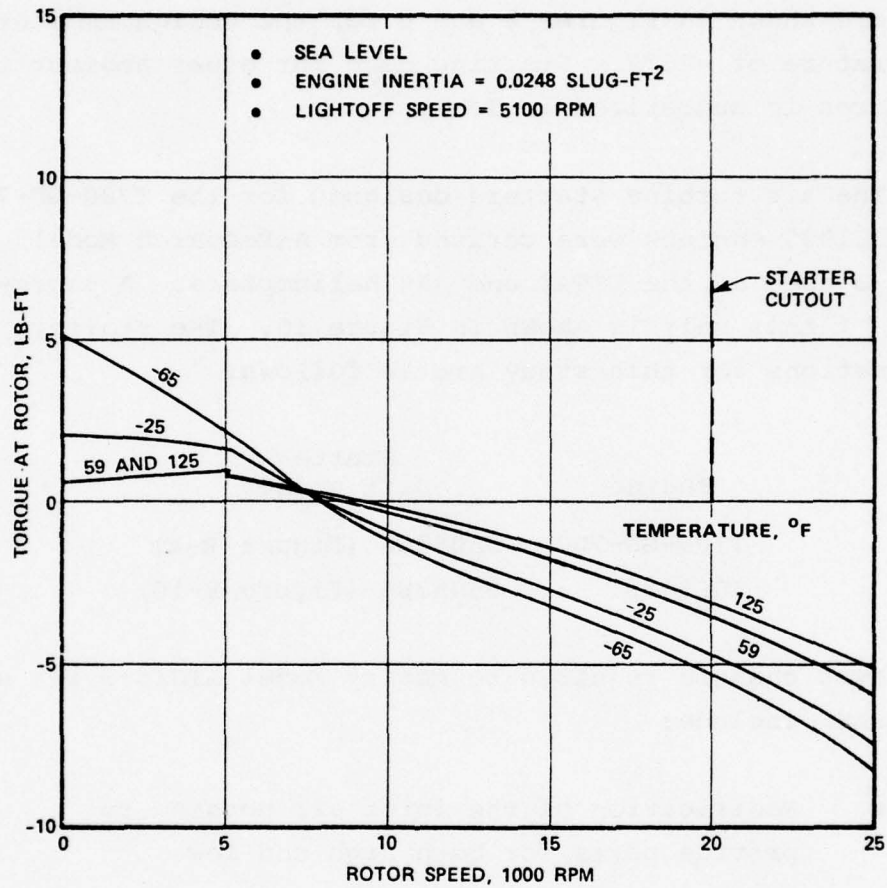

Figure 7. Estimated starting characteristics, TSE1035 engine.

AIR TURBINE STARTER PERFORMANCE CHARACTERISTICS

The starting characteristics of the engines when operated with the air turbine starters in the high-pressure mode are shown in Figures 8 and 9 for the design ambient temperature of -25°F . Starting data for other ambient temperatures is summarized in Table 1.

The air turbine starters designed for the T700-GE-700 and TSE1035 engines were derived from AiResearch Model ATSl8-3 used on the UTTAS and AAH helicopters. A photograph of this unit is shown in Figure 10. The starter designations for this study are as follows:

| <u>Engine</u> | <u>Starter part number</u> |
|---------------|--------------------------------|
| T700-GE-700 | 3505380 (Figure B-4) |
| TSE1035 | 3505386 (Figure B-10) |

The basic changes required to modify Model ATSl8-3 for use with PASS include:

- Modification of the inlet air housing to provide ports for both high and low pressure.
- Redesign of the turbine stator for the partial admission nozzles.
- Reduction gearbox modified to change turbine to output shaft gear ratio from 6.6 to 4.5.

NOTES:

1. SEA LEVEL STATIC CONDITIONS
2. AMBIENT TEMPERATURE = -25°F
3. PERFORMANCE SHOWN IS FOR OPERATION WITH A 3400 IN.^3 PRESSURE VESSEL CHARGED TO 1000 PSIG AT 59°F AND SOAKED TO -25°F
4. ENGINE ROTOR INERTIA = 0.106 SLUG-FT^2 REFERENCE AT STARTER DRIVE SHAFT
5. REGULATOR VALVE SETTING = 235 PSIG
6. TIME TO MINIMUM CUTOUT SPEED = 8.8 SEC
7. TIME TO ENGINE IDLE = 16.2 SEC

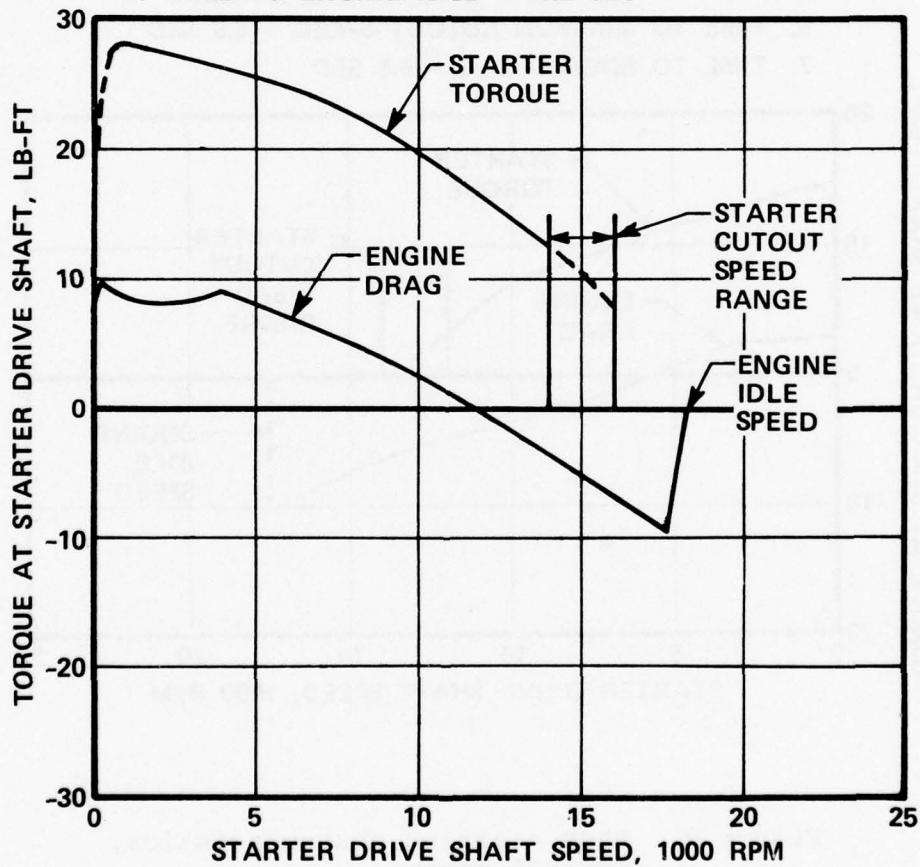

Figure 8. PASS starting characteristics, T700-GE-700 engine.

NOTES:

1. SEA LEVEL STATIC CONDITIONS
2. AMBIENT TEMPERATURE = -25°F
3. PERFORMANCE SHOWN IS FOR OPERATION WITH A 1000 IN.³ PRESSURE VESSEL CHARGED TO 1000 PSIG AT 59°F AND SOAKED TO -25°F
4. ENGINE ROTOR INERTIA = 0.051 SLUG-FT² REFERENCED AT STARTER DRIVE SHAFT
5. REGULATOR VALVE SETTING = 235 PSIG
6. TIME TO MINIMUM CUTOUT SPEED = 5.9 SEC
7. TIME TO ENGINE IDLE = 9.6 SEC

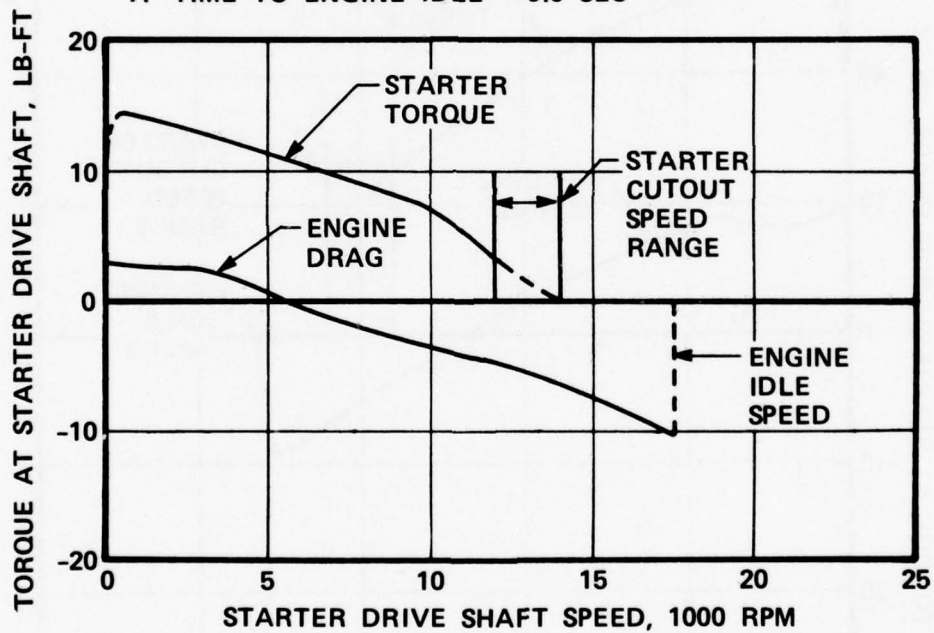

Figure 9. PASS starting characteristics, TSE1035 engine.

TABLE 1. SUMMARY OF ENGINE STARTING CHARACTERISTICS.

| Engine | Ambient temperature (°F) | Pressure vessel volume (in. ³) | Time to minimum cutout speed (sec) | Time to engine idle speed (sec) |
|-------------|--------------------------|--|------------------------------------|---------------------------------|
| T700-GE-700 | 125 | 3400 | 6.8 | 14.4 |
| | 59 | 3400 | 7.2 | 15.1 |
| | -25 | 3400 | 8.8 | 16.2 |
| | -65 | 6800 | 9.4 | 17.7 |
| TSE1035 | 125 | 1000 | 5.6 | 10.0 |
| | 59 | 1000 | 5.6 | 9.7 |
| | -25 | 1000 | 5.9 | 9.6 |
| | -65 | 2000 | 6.3 | 9.3 |

NOTES:

- 1 Performance shown based on pressure vessels charged to 1000 psig at 59°F and soaked to ambient temperatures shown.
- 2 Sea level static conditions.
- 3 Regulator setting = 235 psig.



Figure 10. Air turbine starter Model ATSl8-3.

The generalized performance characteristics of the modified starter configurations are shown in Figures 11 through 14. The data shown is for high- and low-pressure operation.

The performance characteristics of the starters when operated in the low-pressure mode (air supply from pneumatic ground cart) are presented in the discussion of Task V - Logistics.

DESCRIPTION OF PASS COMPONENTS

The drawings that describe the PASS components are listed in Table 2.

Pressure Vessel/Manifold Assembly

The pressure vessel/manifold assembly includes the air bottle for storage of the starting air and the associated control components. The pressure vessel is a filament-wound composite unit with an aluminum liner. This design was selected for the helicopter applications due to its low weight characteristics compared to a metallic pressure vessel and the inherent resistance to shattering when impacted with gun fire.

Although the normal charge pressure is 1000 psig, the pressure vessel is rated to 1600 psig working pressure to allow charging at -65°F and increasing the ambient temperature to +160°F. The pressure vessel is designed to withstand a proof pressure of 2660 psig and a burst pressure of 3520 psig in accordance with the design factors over maximum working pressure per MIL-T-25363.

NOTES:

1. P_1 = STARTER INLET TOTAL PRESSURE, PSIA
2. P_2 = STARTER DISCHARGE STATIC PRESSURE, PSIA
3. N = STARTER OUTPUT SHAFT SPEED, RPM
4. τ = STARTER OUTPUT SHAFT TORQUE, LB-FT
5. W = STARTER AIRFLOW, LB PER MIN
6. T_1 = STARTER INLET TOTAL TEMPERATURE, DEG R
7. STARTER GEAR RATIO = 4.5

$$W \sqrt{\theta_1} / \delta_1 = 2.52$$

$$\theta_1 = T_1 / 518.7$$

$$\delta_1 = P_1 / 14.7$$

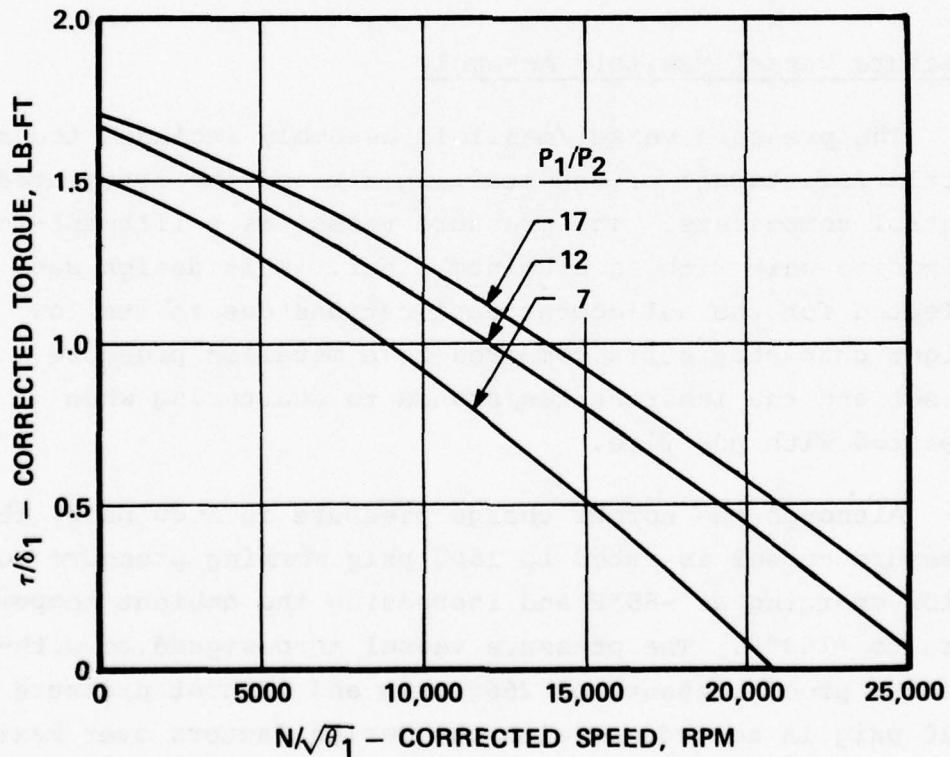

Figure 11. Generalized performance of air turbine starter, Part 3505380 - high-pressure mode of operation.

NOTES:

1. P_1 = STARTER INLET TOTAL PRESSURE, PSIA
2. P_2 = STARTER DISCHARGE STATIC PRESSURE, PSIA
3. N = STARTER OUTPUT SHAFT SPEED, RPM
4. τ = STARTER OUTPUT SHAFT TORQUE, LB-FT
5. W = STARTER AIRFLOW, LB PER MIN
6. T_1 = STARTER INLET TOTAL TEMPERATURE, DEG R
7. STARTER GEAR RATIO = 4.5

$$W \sqrt{\theta_1} / \delta_1 = 13.5$$

$$\theta_1 = T_1 / 518.7$$

$$\delta_1 = P_1 / 14.7$$

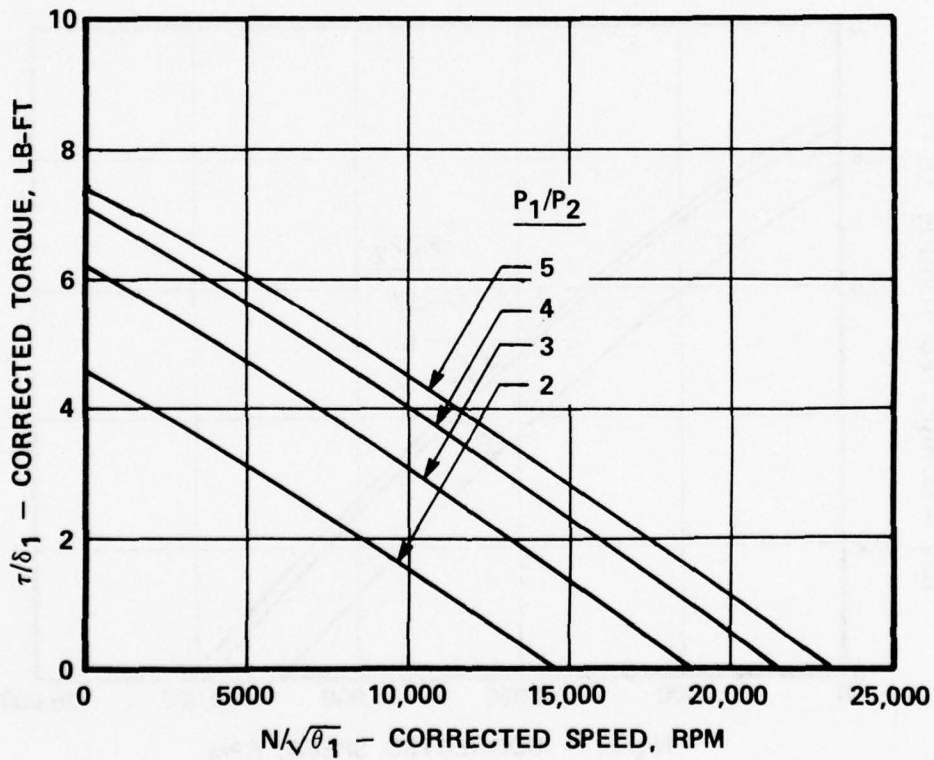

Figure 12. Generalized performance of air turbine starter, Part 3505380 - low-pressure mode of operation.

NOTES:

1. P_1 = STARTER INLET TOTAL PRESSURE, PSIA
2. P_2 = STARTER DISCHARGE STATIC PRESSURE, PSIA
3. N = STARTER OUTPUT SHAFT SPEED, RPM
4. τ = STARTER OUTPUT SHAFT TORQUE, LB-FT
5. W = STARTER AIRFLOW, LB PER MIN
6. T_1 = STARTER INLET TOTAL TEMPERATURE, DEG R
7. STARTER GEAR RATIO = 4.5

$$W \sqrt{\theta_1/\delta_1} = 1.27$$

$$\theta_1 = T_1/518.7$$

$$\delta_1 = P_1/14.7$$

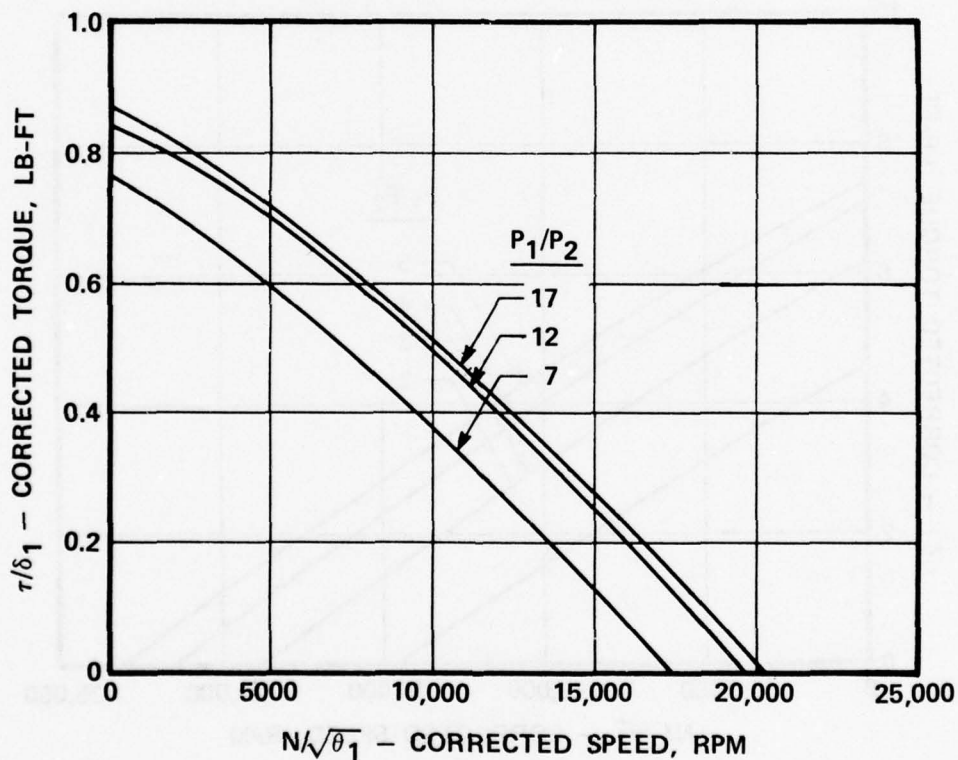

Figure 13. Generalized performance of air turbine starter, Part 3505386 - high-pressure mode of operation.

NOTES:

1. P_1 = STARTER INLET TOTAL PRESSURE, PSIA
2. P_2 = STARTER DISCHARGE STATIC PRESSURE, PSIA
3. N = STARTER OUTPUT SHAFT SPEED, RPM
4. τ = STARTER OUTPUT SHAFT TORQUE, LB-FT
5. W = STARTER AIRFLOW, LB PER MIN
6. T_1 = STARTER INLET TOTAL TEMPERATURE, DEG R
7. STARTER GEAR RATIO = 4.5

$$W \sqrt{\theta_1} / \delta_1 = 10.5$$

$$\theta_1 = T_1 / 518.7$$

$$\delta_1 = P_1 / 14.7$$

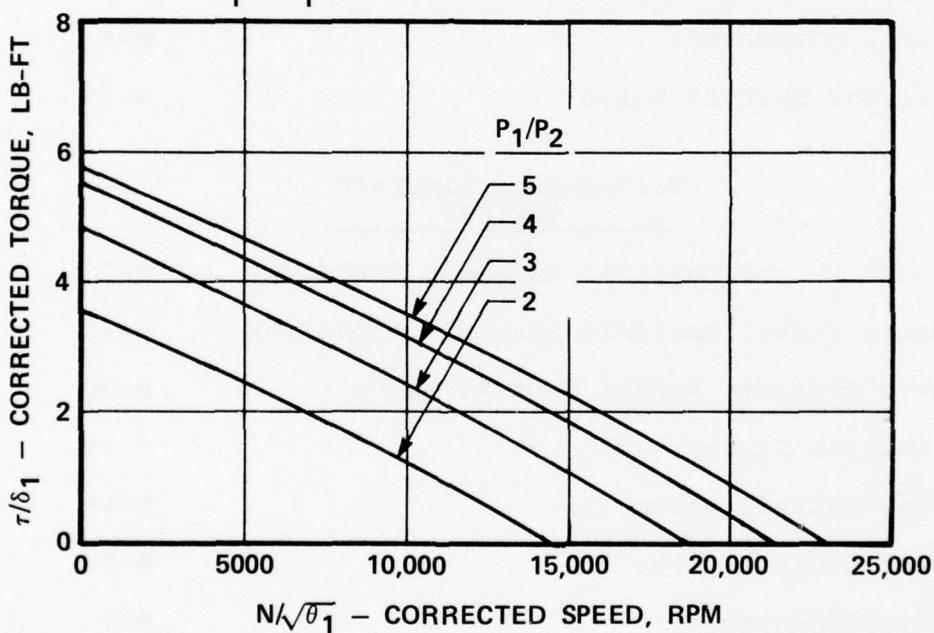

Figure 14. Generalized performance of air turbine starter, Part 3505386 - low-pressure mode of operation.

TABLE 2. LIST OF PASS COMPONENT DRAWINGS.

| Component | Figure** number |
|---|--------------------|
| <u>Single-Engine Aircraft</u> <u>T700-GE-700</u> | |
| Pressure Vessel/Manifold Assembly (Primary) | B-1 |
| Pressure Vessel/Manifold Assembly (Reserve) | B-2 |
| Reserve Pressure Vessel Shutoff Valve | B-3* |
| Air Turbine Starter | B-4 |
| Starter Control Valve | B-5 |
| Recharge Compressor | B-6 |
| Compressor Shutoff Valve | B-3* |
| <u>Twin-Engine Aircraft</u> <u>TSE1035</u> | |
| Pressure Vessel/Manifold Assembly (Primary) | B-7 |
| Pressure Vessel/Manifold Assembly (Reserve) | B-8 |
| Reserve Pressure Vessel Shutoff Valve | B-9* |
| Air Turbine Starter (2) | B-10 |
| Starter Shutoff Valve (2) | B-9* |
| Starter Control Valve (2) | B-5 |
| Recharge Compressor | B-6 |
| Compressor Shutoff Valve | B-3* |

* Common parts.

** These figures are attached at the end of the report.
as Appendix B.

The control manifold assembly is attached to the outlet of the pressure vessel as illustrated on the outline drawing. The control manifold includes the moisture collector and provides mounting provisions for the following control components.

- Ground service fill valve
- Burst disc
- Pressure gauge
- Recharging check valve
- Recharging pressure switch
- Pressure regulating and shutoff valve

Connections are also provided for the supply line from the recharge compressor and reserve pressure vessel.

The outlet of the pressure regulating and shutoff valve mates with a 1.0-inch (MS33656E16) line size for the T700-GE-700 engine and with a 3/4-inch (MS33656E12) line for the TSE1035 engine.

The pressure vessel/manifold assembly includes a moisture removal system to prevent entrained moisture in the compressed air from accumulating in the pressure vessel. The moisture removal system is illustrated schematically in Figure 15. During an engine start cycle, any entrained moisture in the bottle is siphoned to a moisture collector using a flexible tube that is internal to the unit. Due to the pressure drop across the neck of the bottle, the higher pressure in the bottle forces any liquid through the siphon tube. The moisture will pass through the regulator and shutoff valve and on to the air turbine starter.

SYSTEM ARRANGEMENT

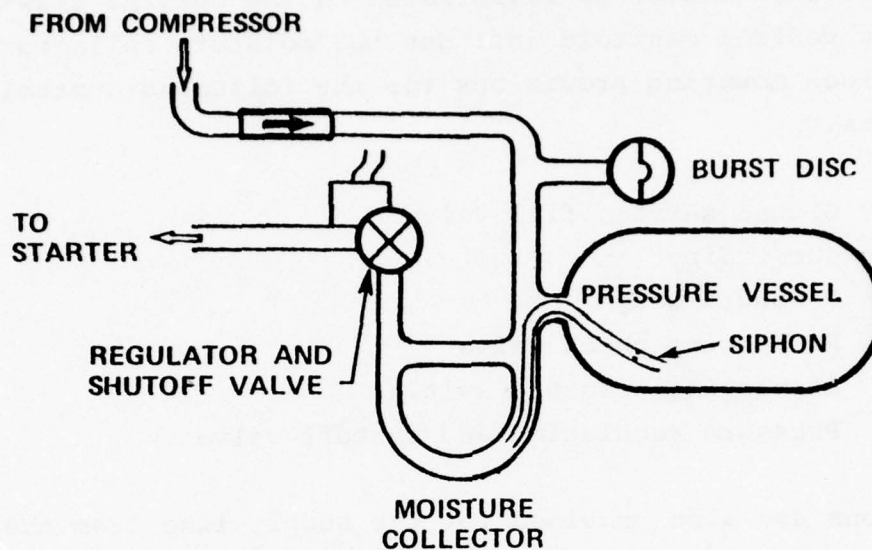

SYSTEM OPERATION

- ENTRAINED MOISTURE FROM COMPRESSED AIR COLLECTS IN PRESSURE VESSEL AND MOISTURE COLLECTOR DURING RECHARGE CYCLE
- MOISTURE IS SIPHONED FROM PRESSURE VESSEL TO COLLECTOR AND DISCHARGES TO STARTER WHEN REGULATOR AND SHUTOFF VALVE IS OPENED
- DUAL FLOW PATH TO VALVE PRECLUDES BLOCKAGE DUE TO FREEZING

Figure 15. Moisture removal system.

The moisture collector is located to trap any liquid that does not expel during the start cycle. This prevents entrained water from freezing on the valve seat when operated at low temperatures. A redundant flow path to the regulator is also provided in the event water does freeze in the collector.

Reserve Pressure Vessel/Manifold Assembly

The reserve pressure vessel is identical to the primary unit except the manifold that attaches to the outlet requires only a pressure gauge and burst disc. The outlet connection mates with the reserve pressure vessel shutoff valve. The shutoff valve is a normally closed, solenoid-operated valve requiring 28-vdc electrical power for operation.

Recharge Compressor

The recharge compressor is a two-stage piston compressor driven by an air turbine. The compressor is illustrated schematically in Figure 16. The two compressor cylinders are opposed 180 degrees and driven by a crankshaft through connecting rods and wrist pins. A two-mesh spur gearbox is attached to the compressor crankshaft to reduce the speed of the air turbine from 60,000 to 4000 rpm at the crankshaft. The bearings, gears, and cylinder walls are lubricated by a splash-type oil sump.

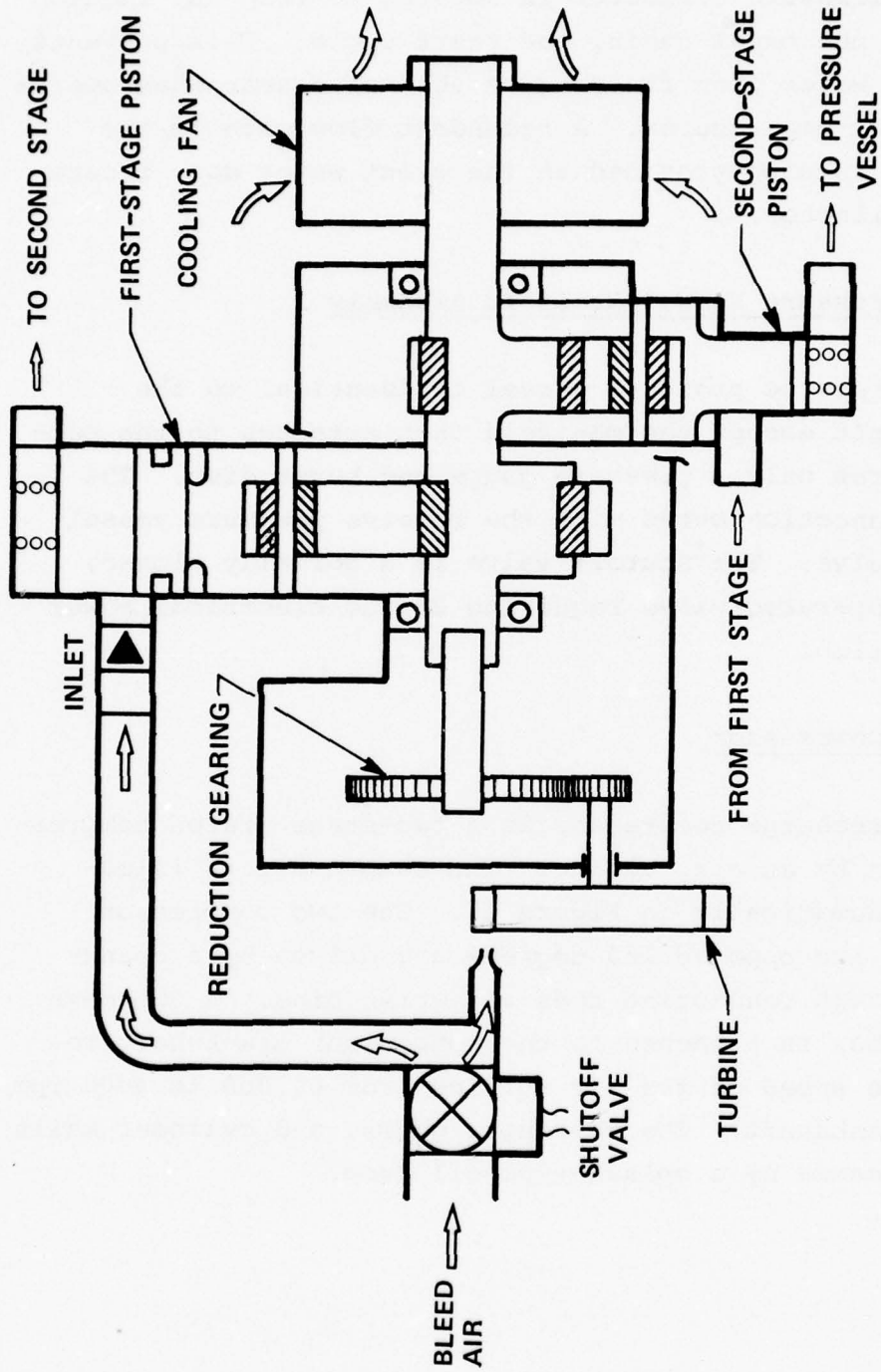

Figure 16. Schematic of recharge compressor.

The compressor is cooled by a fan that is attached to the crankshaft. The fan is an axial-flow unit that intakes compartment air and discharges it across the compressor cylinders and motor.

As shown in the schematic, bleed air is used to charge the inlet of the compressor as well as to drive the turbine. Since the bleed air is already pressurized, the inlet-air density to the compressor intake is higher than if ambient air were compressed. This reduces the required compression ratio of the unit and reduces the required displacement.

The drive motor (air turbine) is a partial-admission 3.2-inch-diameter axial-flow turbine. Exhaust from the turbine is collected and ducted overboard the aircraft.

During the recharge cycle of the pressure vessel, the speed of the compressor will vary as a function of the discharge pressure and available bleed-air pressure and temperature. The compressor drive motor has been designed to limit the crankshaft speed to approximately 6000 rpm when the pressure vessel is at zero psig.

The required bleed airflow to operate the compressor is shown in Figure 17 for various inlet air pressures and temperatures. The required recharge time to replace the air used during the start cycle is shown in Figures 18 and 19 for the T700-GE-700 and TSE1035 engines, respectively.

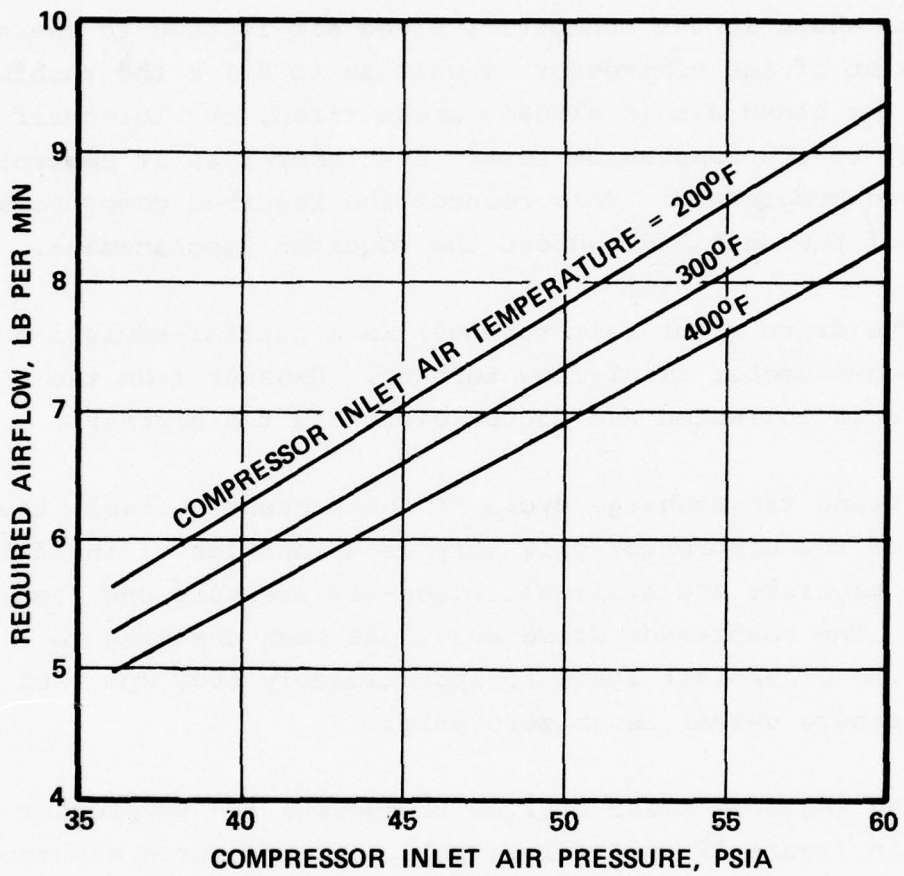

Figure 17. Compressor bleed-air requirements.

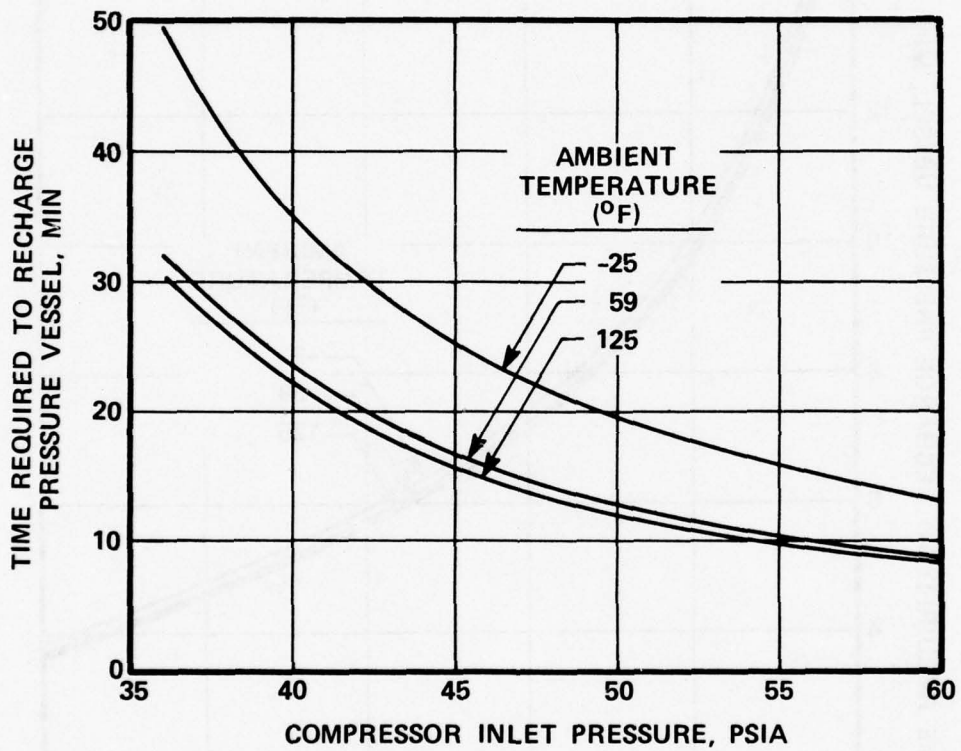

Figure 18. Compressor recharge characteristics, T700-GE-700 engine.

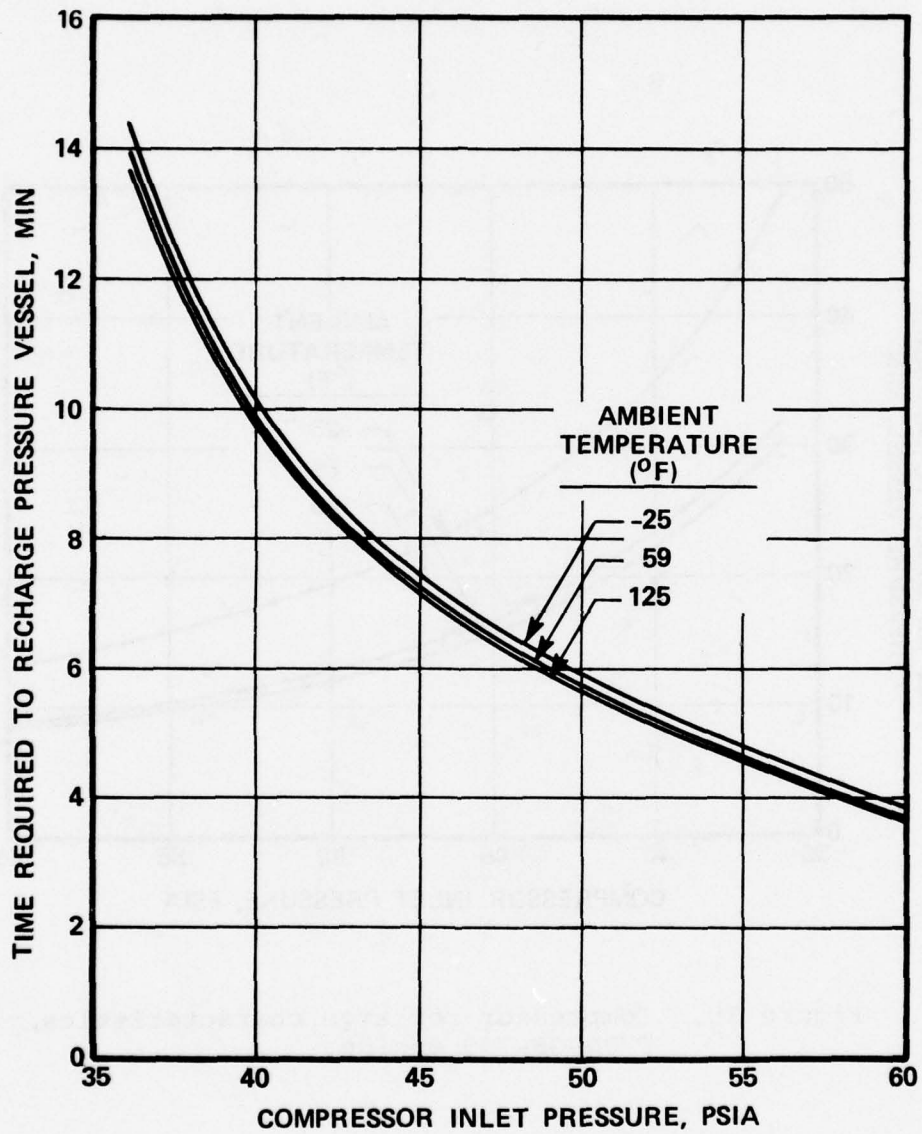

Figure 19. Compressor recharge characteristics, TSE1035 engine.

Compressor Shutoff Valve

The compressor shutoff valve is a normally closed, solenoid-operated valve. When electrical power (28 vdc) is available to operate the system, the valve will be energized open when the pressure switch (located on the pressure vessel control manifold) is closed at 900 psig. The electrical circuit is de-energized when the pressure reaches a value between 1000 and 1050 psi.

Air Turbine Starter

The air turbine starter (ATS) is a dual-operating mode (Hi-Lo) unit capable of operating with a high-pressure or low-pressure air supply. The ATS consists of two basic sections: an aerodynamic section and a gear reduction section. A cross-sectional sketch showing the basic components of the starter is shown in Figure 20.

The aerodynamic section consists of the inlet housing and bifurcated stator assembly, turbine wheel, turbine pinion gear, containment ring, and exhaust housing. The airflow path for both the high-pressure and low-pressure operating modes is illustrated in Figure 21.

The gear reduction section consists of the gear reduction housing, four spur reduction gears, the output shaft and decoupler assembly, the clutch assembly, and a monopole speed sensor. The gear reduction system is a jack-shaft type arrangement. The turbine pinion gear drives the first spur gear of the jack-shaft cluster which is supported at

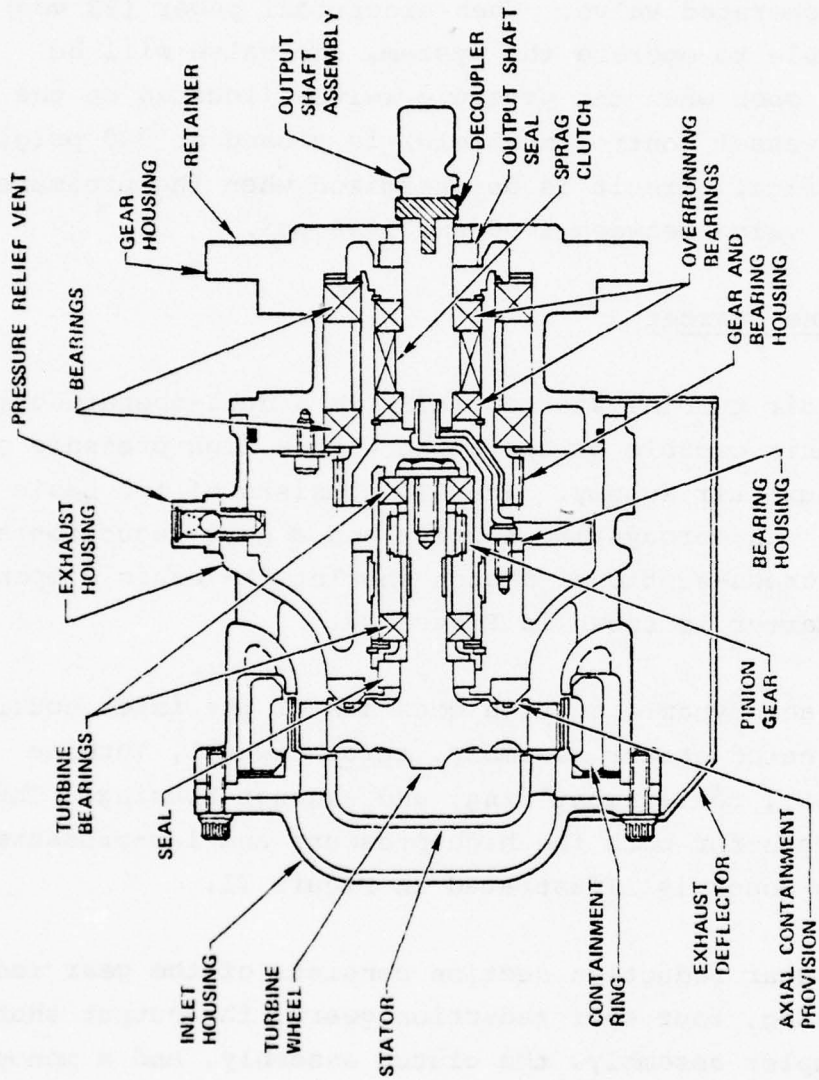

Figure 20. Cross section of air turbine starter.

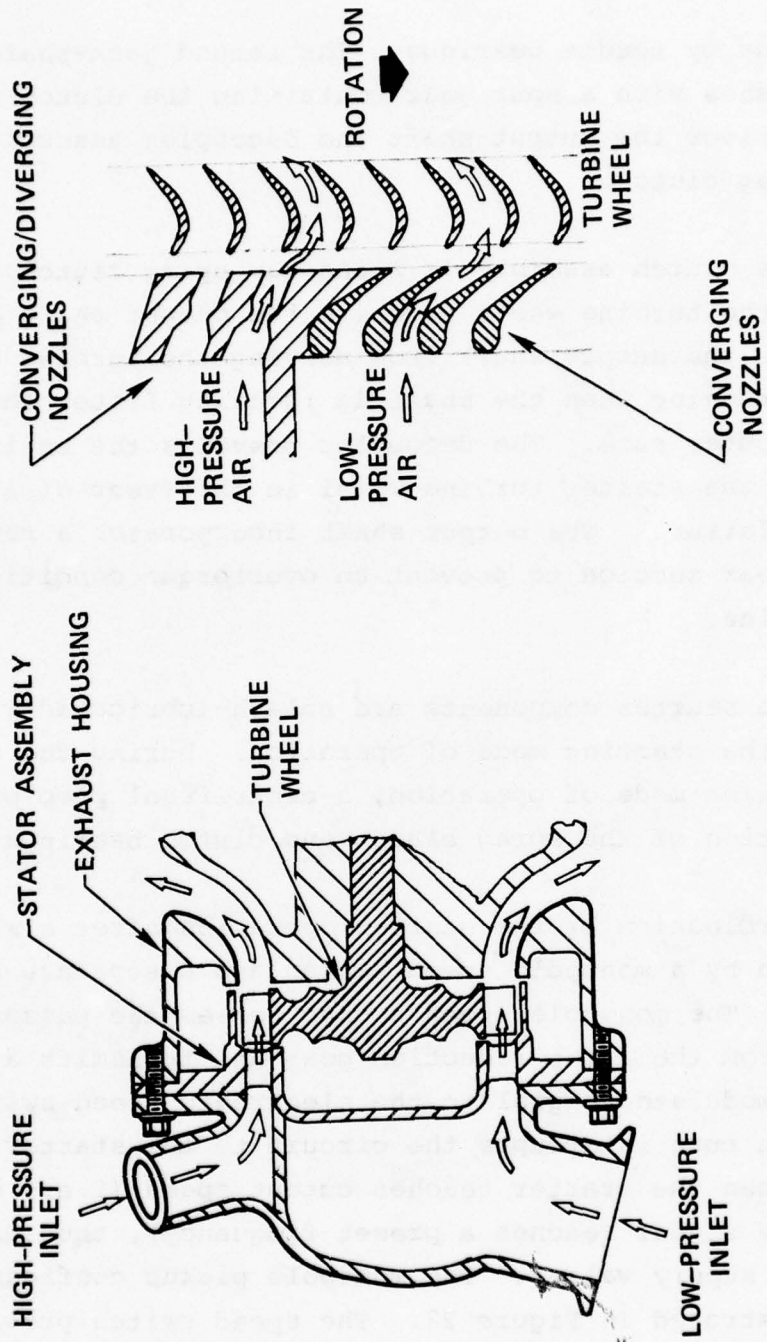

Figure 21. Airflow path - air turbine starter.

both ends by needle bearings. The second jack-shaft spur gear meshes with a spur gear containing the clutch assembly which drives the output shaft and decoupler assembly through the sprag clutch.

The clutch assembly is a one-way sprag clutch, which allows the turbine wheel to drive the output shaft but prevents the output shaft from driving the turbine wheel by overrunning when the shaft is rotating faster than the clutch outer race. The decoupler prevents the engine from driving the starter turbine wheel in the event of a sprag clutch failure. The output shaft incorporates a replaceable shear section to prevent an overtorque condition to the engine.

The starter components are splash-lubricated with oil during the starting mode of operation. During the starter overrunning mode of operation, a centrifugal pump provides lubrication of the sprag clutch and clutch bearings.

Termination of the starter operation after a start is provided by a monopole speed pickup and a separate speed switch. The monopole speed pickup senses the passage of teeth from the first reduction gear and transmits a frequency modulated signal to the electronic speed switch, which in turn interrupts the circuit to the starter control valve when the starter reaches cutout speed (i.e., when the monopole signal reaches a preset frequency), thus closing the air supply valves. The monopole pickup configuration is illustrated in Figure 22. The speed switch provides automatic cutout of the starter and, in the twin-engine installation, both starters use one speed switch.

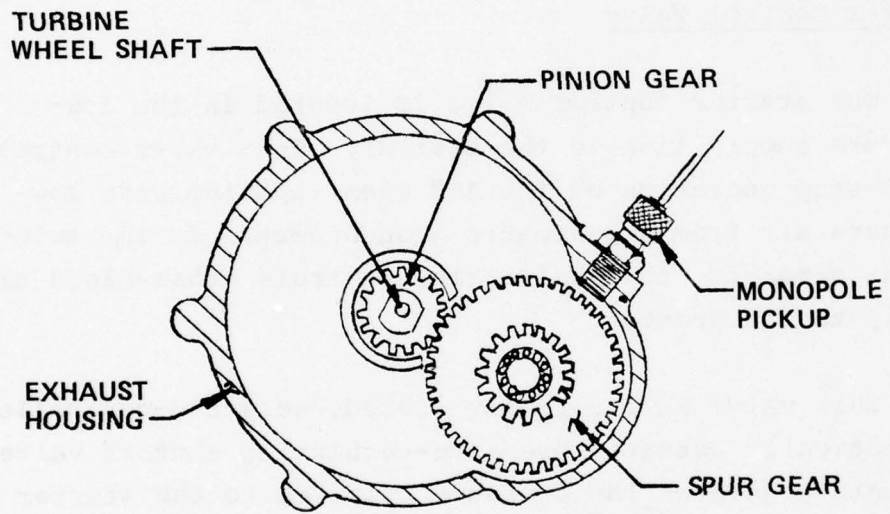

Figure 22. Monopole pickup configuration.

Starter Shutoff Valve

In the twin-engine aircraft, a starter shutoff valve is located in the high-pressure supply line to the starter. This valve is a normally closed, solenoid-operated (28-vdc) valve. This valve is opened by actuation of the cockpit start switch and is automatically closed by the starter speed switch.

Starter Control Valve

The starter control valve is located in the low-pressure supply line to the starter. This valve controls start-stop operation of the ATS when supplied with low-pressure air from a pneumatic ground cart. In the twin-engine aircraft, this valve also controls cross-bleed air supply to the starter.

This valve is a normally closed, solenoid-controlled, pneumatically actuated pressure-regulating shutoff valve. The unit regulates the pressure supplied to the starter to 40 psig in the event the supply pressure is above this value. The valve also incorporates a controlled opening rate to limit the downstream pressure during initial start-up to prevent high impact torques during engagement of the starter.

The valve has a butterfly-type modulating and closure element. A diaphragm-type pneumatic actuator is mechanically attached to the butterfly.

PASS COMPONENT WEIGHTS

The estimated weights of the PASS components are presented in Tables 3 and 4 for the T700-GE-700 and TSE1035 engines, respectively. The components are identified by an item number. The item numbers are shown in Figures 23 and 24, which show schematics of each aircraft configuration.

PASS INSTALLATION CHARACTERISTICS

In order to evaluate the installation characteristics of PASS in an advanced helicopter, Bell Helicopter supported this activity. An analysis was conducted to locate the components in the aircraft and to estimate the required line sizes and lengths of the pneumatic ducting. An evaluation of the required battery size to meet ground electrical systems checkout and emergency inflight power was also conducted.

A sketch showing the PASS components located in the aircraft for the single-engine installation is shown in Figure 25.

PASS components that require an interface with the airframe structure include:

- Pneumatic lines
- Electrical wiring for control interface
- Recharge compressor
- Pressure vessels

TABLE 3. WEIGHT SUMMARY OF PRESSURIZED AIR START SYSTEM FOR THE T700-GE-700 ENGINE.

| Item* | Component | Weight (lb) |
|-------|--|----------------|
| 1 | Pressure Vessel, Primary - 3400 cu in. | 31.0 |
| 2 | Pressurized Air in Item 1 | 10.4 |
| 3 | Pressure Vessel, Reserve - 3400 cu in. | 25.0 |
| 4 | Pressurized Air in Item 3 | 10.4 |
| 5 | Reserve Pressure** Vessel Solenoid Shutoff Valve | 1.8 |
| 6 | Compressor, Turbine Driven | 18.0 |
| 7 | Compressor** Solenoid Shutoff Valve | 1.8 |
| 8 | Starter, Air Turbine | 8.5 |
| 9 | Starter Control Valve | <u>2.9</u> |
| | TOTAL | 109.8 lb |

* See Figure 23

** Common Parts

TABLE 4. WEIGHT SUMMARY OF PRESSURIZED AIR START SYSTEM FOR THE TSE1035 ENGINE.

| Item* | Component | Weight (lb) |
|-------|--|----------------|
| 1 | Pressure Vessel, Primary - 1000 cu in. | 13.6 |
| 2 | Pressurized Air in Item 1 | 3.1 |
| 3 | Pressure Vessel, Reserve - 1000 cu in. | 8.1 |
| 4 | Pressurized Air in Item 3 | 3.1 |
| 5 | Reserve Pressure** Vessel Solenoid Shutoff Valve | 1.6 |
| 6 | Compressor, Turbine Driven | 18.0 |
| 7 | Compressor Solenoid Shutoff Valve | 1.8 |
| 8 | Starter, Air Turbine (2) | 17.0 |
| 9 | Starter Control Valve (2) | 5.8 |
| 10 | Shutoff Valve** (2) | <u>3.2</u> |
| | TOTAL | 75.3 lb |

* See Figure 24

** Common Parts

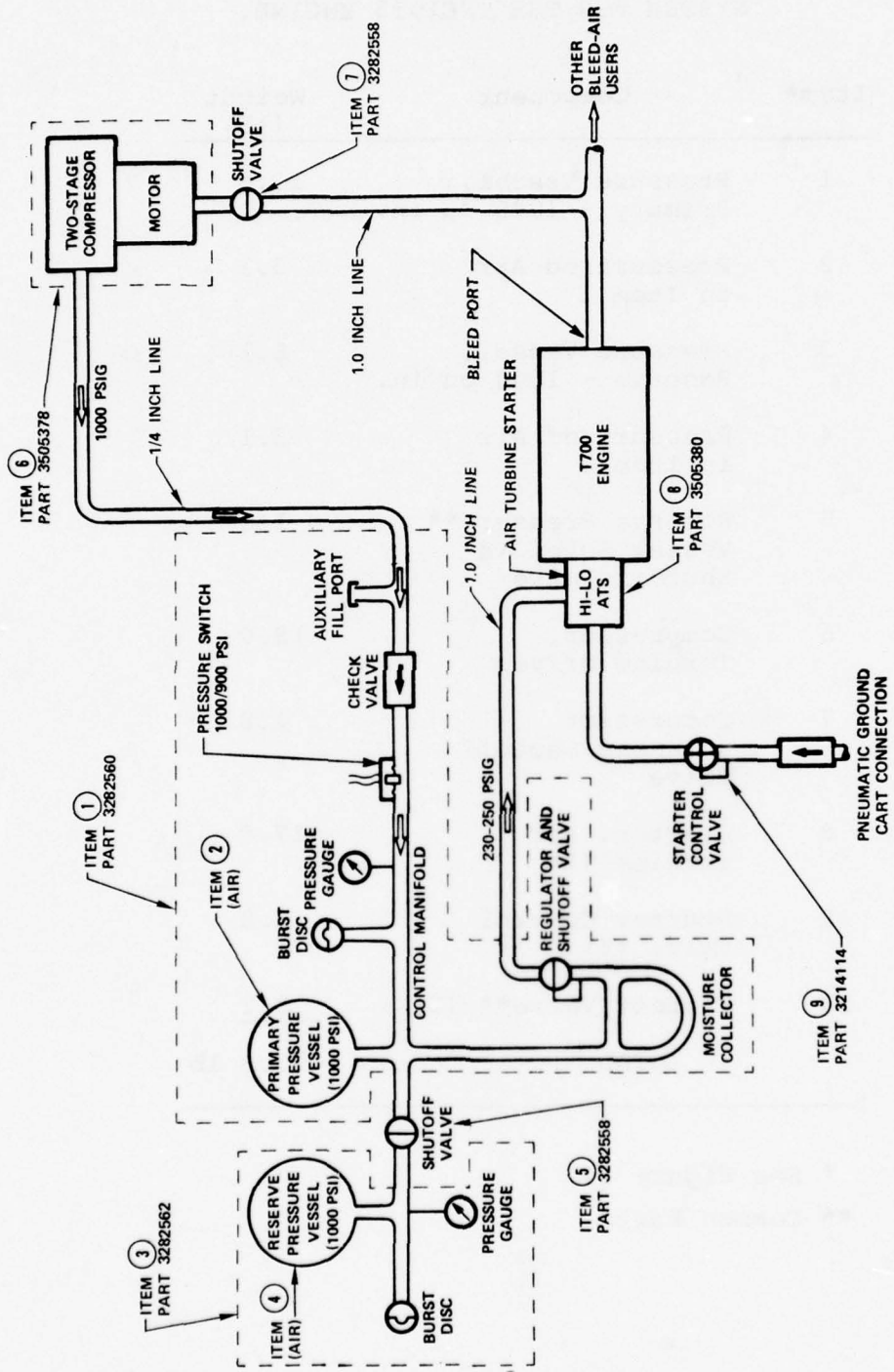

Figure 23. PASS system schematic (single-engine).

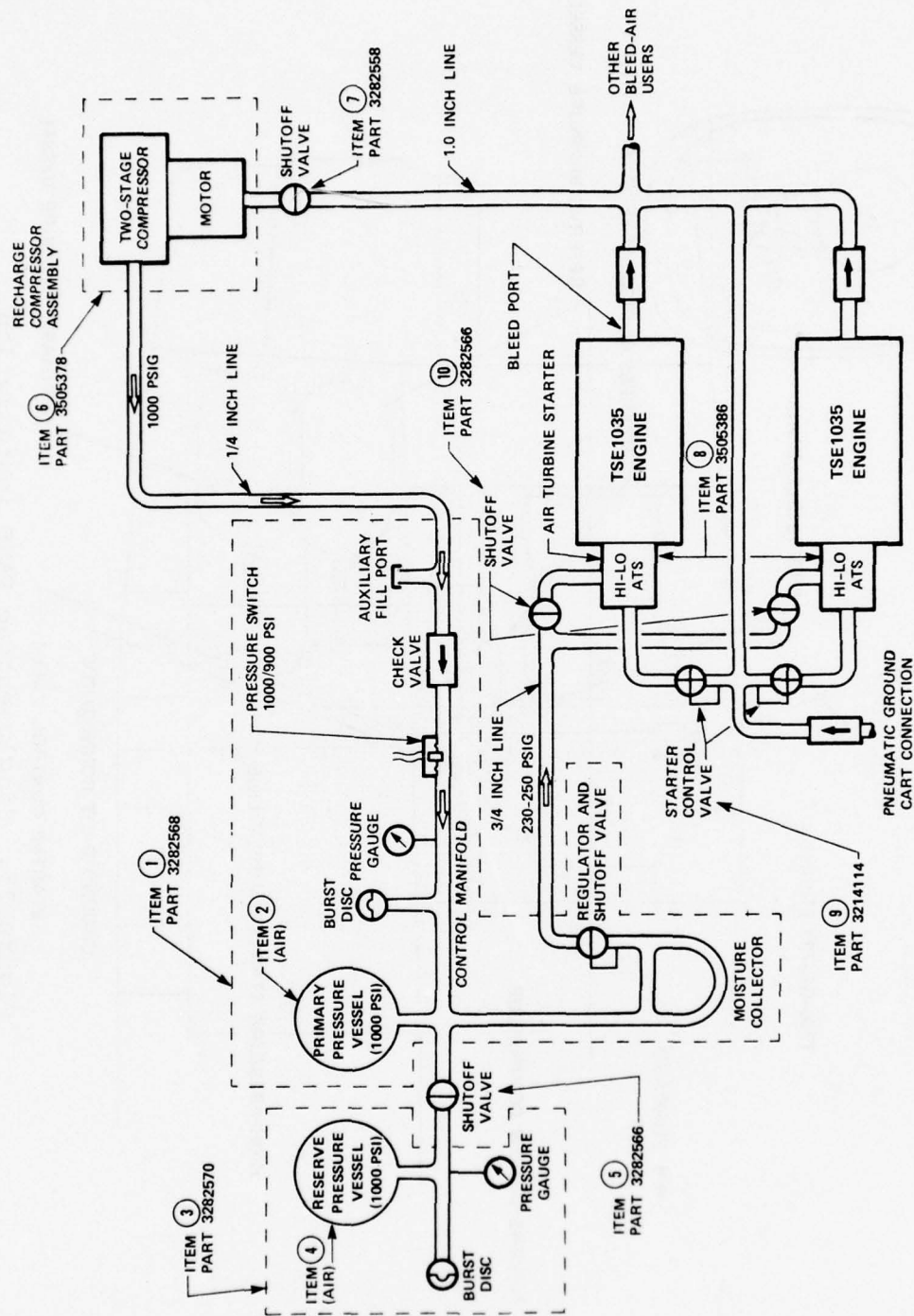

Figure 24. PASS system schematic (twin-engine).

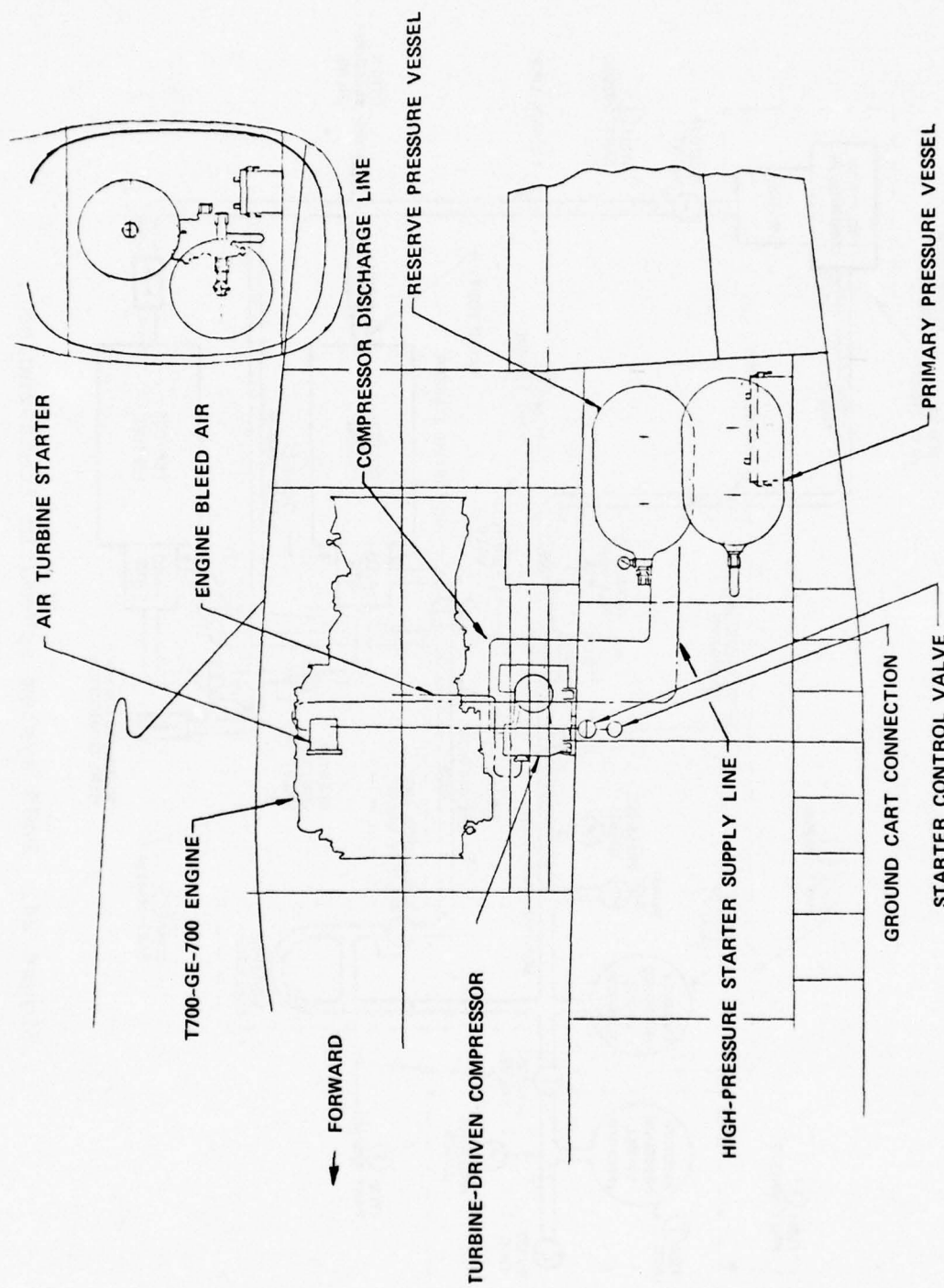

Figure 25. Single-engine PASS installation.

Due to the relatively light weight of these components, mounting can be accomplished by attaching to frames used in aircraft structure.

The compressor includes a three-point mounting system, as shown in Figure 47. The unit is attached to the airframe using bolts through the mounting legs and vibration isolating flexible bases.

The compressor compartment is ventilated to allow cooling air from the compressor fan to be discharged overboard. The turbine exhaust from the drive motor is ducted overboard through nominal 1.50-inch ID tubing.

The pressure vessels are attached to the airframe using quick-disconnect clamps. Dual clamps are used around the cylindrical portions of the pressure vessels.

The estimated line lengths and sizes for connecting the various PASS components are presented in Table 5. The estimated weight addition to the system for the ducting is:

| | |
|---------------------------|-------|
| Single T700-GE-700 Engine | 8 lb |
| Dual TSE1035 Engines | 14 lb |

In order to meet ground electrical systems checkout and emergency inflight power and to provide electrical power for control functions during starting, Bell estimated

TABLE 5. PNEUMATIC LINE LENGTHS AND SIZES FOR PASS INSTALLATION.

| Line | Length (in.) | Diameter (in.) |
|--|-----------------|-------------------|
| <u>Single T700-GE-700 Engine</u> | | |
| High-Pressure Starter Supply | 75 | 1.00 |
| Reserve Pressure Vessel to Primary | 20 | 1.00 |
| Compressor Discharge to Pressure Vessel | 36 | 0.25 |
| Ground Cart Connection to Starter | 42 | 2.00 |
| <u>Twin TSE1035 Engines</u> | | |
| High-Pressure Starter Supply | 147 | 0.75 |
| Reserve Pressure Vessel to Primary | 20 | 0.75 |
| Compressor Discharge to Pressure Vessel | 36 | 0.25 |
| Low-Pressure Supply Line from Ground Cart Connection and Cross-Bleed | 114 | 2.00 |

that a ~~13 ampere-hour~~ battery will be required. The estimated weight addition to the start system for the battery is:

| | |
|---------------------|-------------|
| Battery | 26 lb |
| Battery conditioner | 10 lb |
| Battery relay | <u>3 lb</u> |
| TOTAL | 39 lb |

Typical dimensions of the battery and battery conditioner are illustrated in Figure 26.

Cockpit switches required for operating the single-engine system include:

- Engine PASS start switch
- Engine ground cart start switch
- Reserve pressure vessel switch
- Compressor ON-OFF switch

Cockpit switches required for operating the twin-engine system include:

- No. 1 Engine PASS start switch
- No. 2 Engine PASS start switch
- No. 1 Engine ground cart/cross-bleed switch
- No. 2 Engine ground cart/cross-bleed switch
- Reserve pressure-vessel switch
- Compressor ON-OFF switch

NOTE: DIMENSIONS SHOWN
IN INCHES.

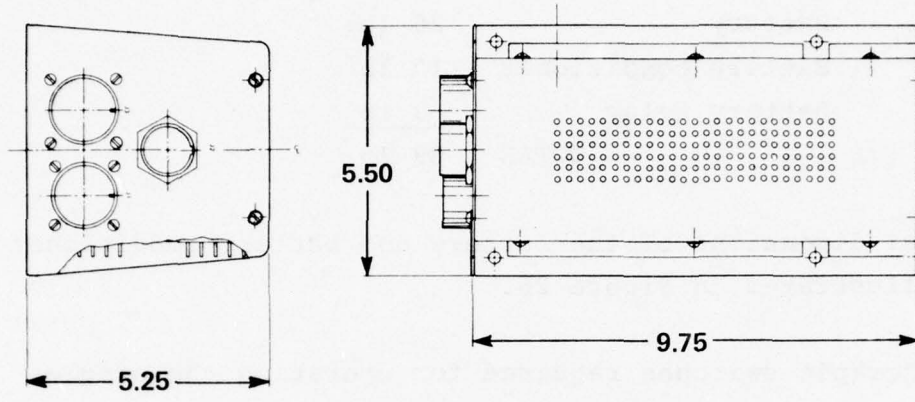

BATTERY CONDITIONER

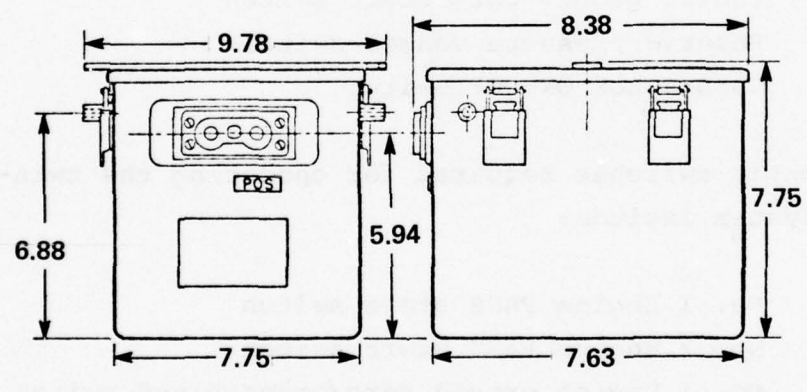

13-AH Ni-Cd BATTERY

Figure 26. Battery and conditioner dimensions.

For both the single- and twin-engine installation, a cockpit indicator light is used to indicate when the pressure vessel reaches rated pressure. The signal for this light is provided by the pressure switch located on the primary pressure vessel/manifold assembly.

PASS COMPARISON WITH ELECTRIC START SYSTEM

An evaluation of an electric start system for both the T700-GE-700 and TSE1035 engines was conducted for comparison with the pressurized air start system. The starting requirements for the electric system were assumed to be the same as those used in sizing the PASS components, i.e., two starts at sea level, -25°F conditions.

Electric Start Analysis

The system arrangements selected as a result of the electric start analysis are shown in Figures 27 and 28 for the T700-GE-700 and TSE1035 engines, respectively. Starting analyses were conducted for various standard battery sizes (13-AH, 22-AH, and 34-AH) and arrangements (parallel, series, and parallel/series) in order to determine the system that would meet the -25°F start requirements.

The electric starting characteristics of the T700-GE-700 engine are shown in Figure 29 for the -25°F design condition. Three 22-amp-hr batteries are required to provide adequate starting for the T700-GE-700 engine at -25°F. The electric starter that has been considered is Model GE 2CM272A1 which was designed for this engine. The

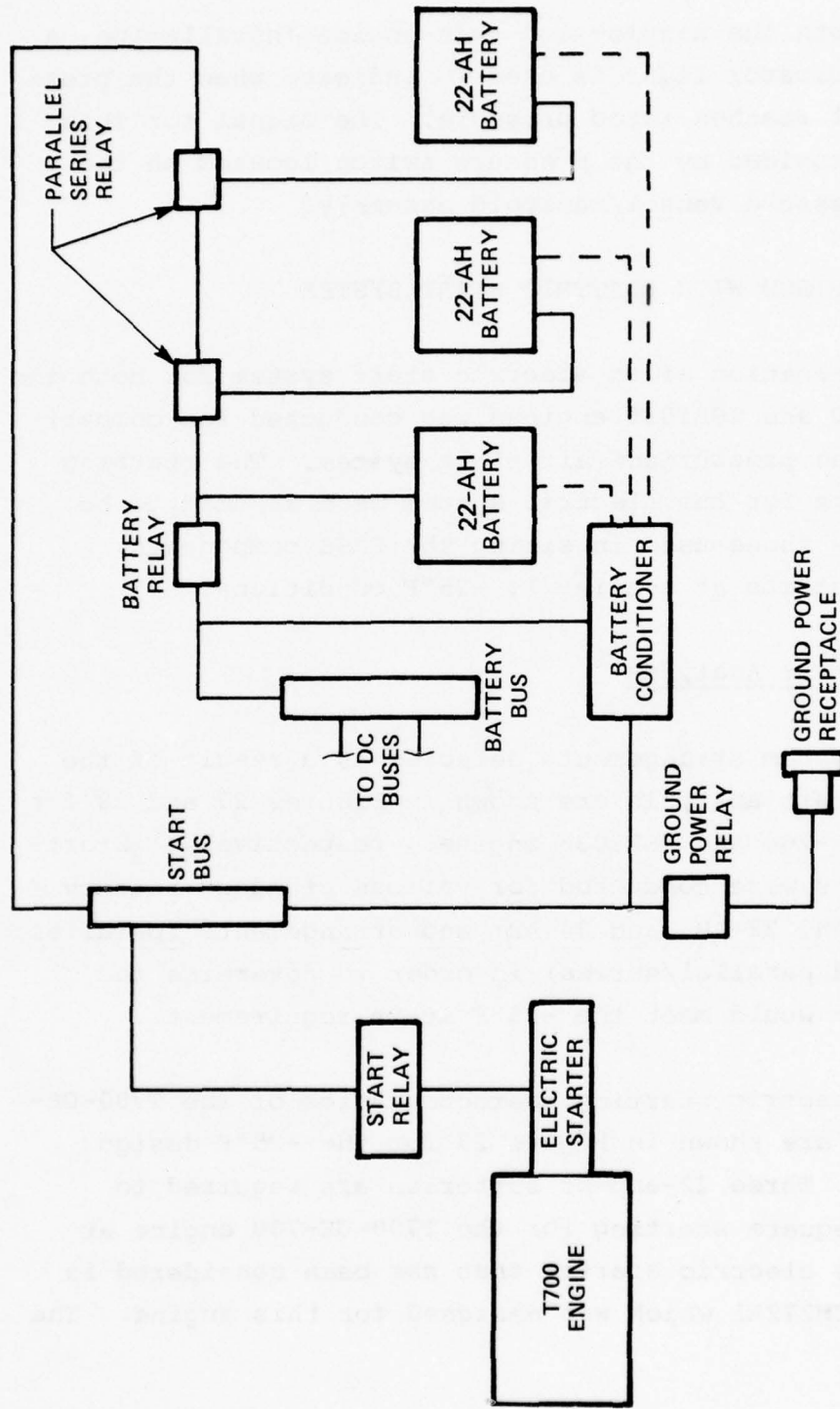

Figure 27. Electric start system - single-engine aircraft.

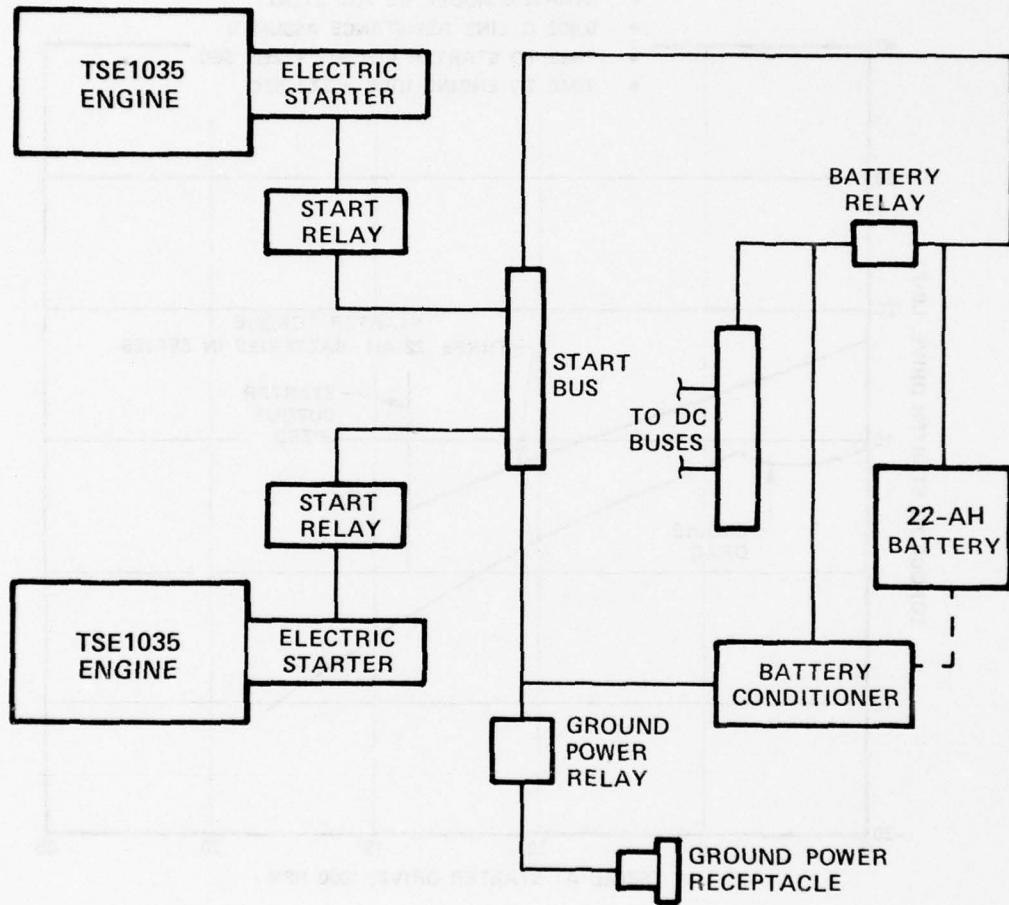

Figure 28. Electric start system - twin-engine aircraft.

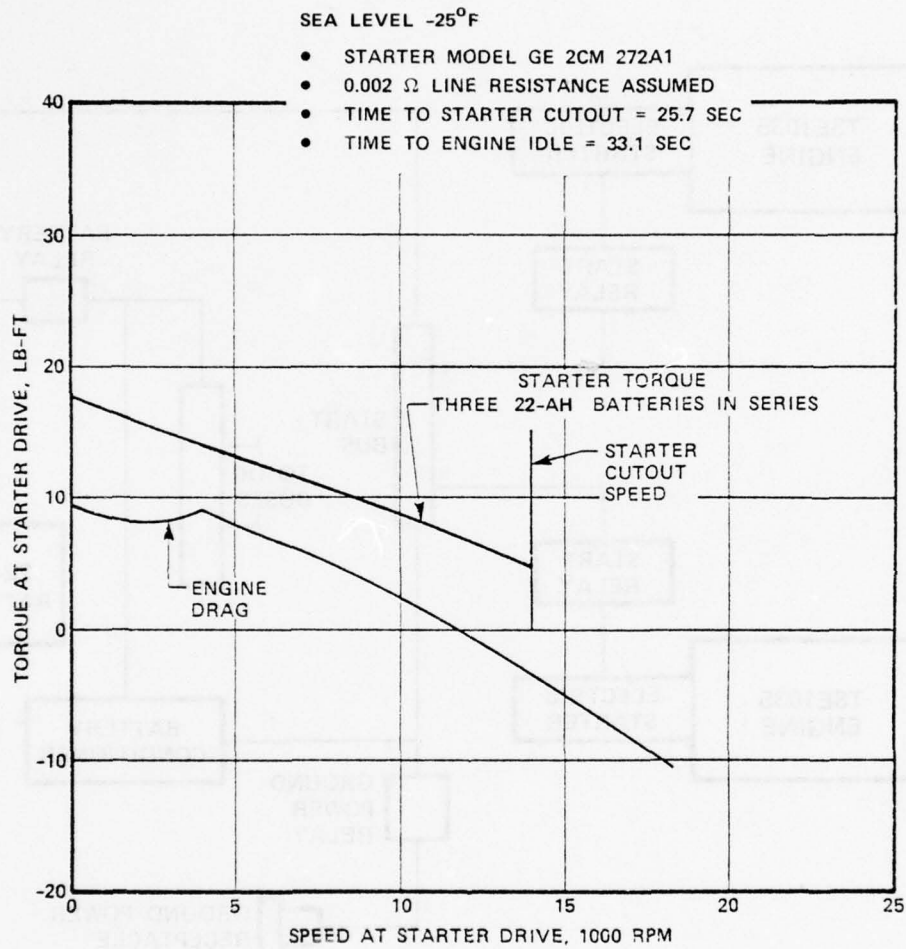

Figure 29. Electric start analysis - T700-GE-700 engine.

generalized performance characteristics of the starter are shown in Figure 30. The discharge characteristics for low-resistance 22 AH nickel-cadmium batteries used in the analysis are shown in Figure 31.

The results of the electric start analysis for the TSE1035 engine are shown in Figure 32. A single 22-amp-hr battery will provide adequate starting of this engine at -25°F. AiResearch Model 519802-4 starter was selected for this engine. This starter is used to start AiResearch Model 660 Auxiliary Power Unit (APU) on the Boeing 747 aircraft. The generalized performance characteristics of this starter are shown in Figure 33.

Performance Comparison

As shown on Table 6, the Pressurized Air Start System provides reduced acceleration times compared to the electric start system. This results from torque available from the air turbine starter near starter cutout speed being higher than that of the electric starter. The decrease of a few seconds in engine start time is usually not significant to mission effectiveness of the helicopter. However, the reduction in start time does have an impact on the life of the main propulsion engine.

After lightoff has occurred in the engine start cycle, the starting fuel schedule usually results in engine turbine inlet temperatures equal to or greater than the turbine inlet temperature at takeoff rating. The longer the engine is exposed to these temperatures, the shorter the turbine life.

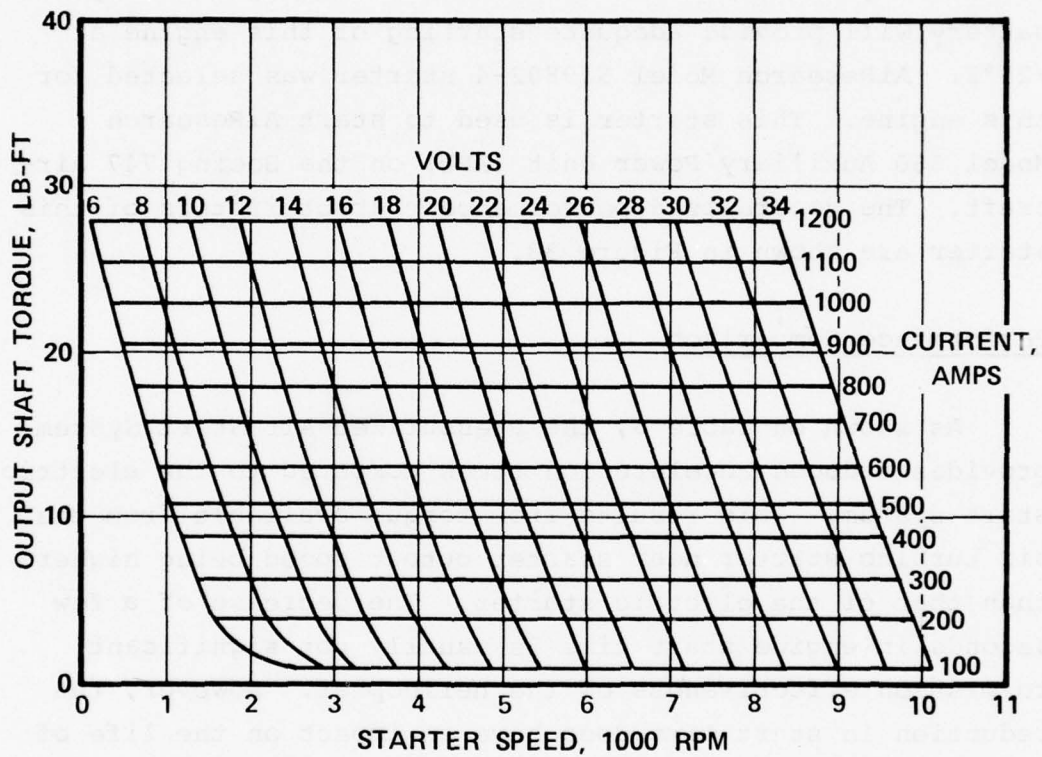

Figure 30. Generalized performance -
 Model GE 2CM272A1 electric starter.

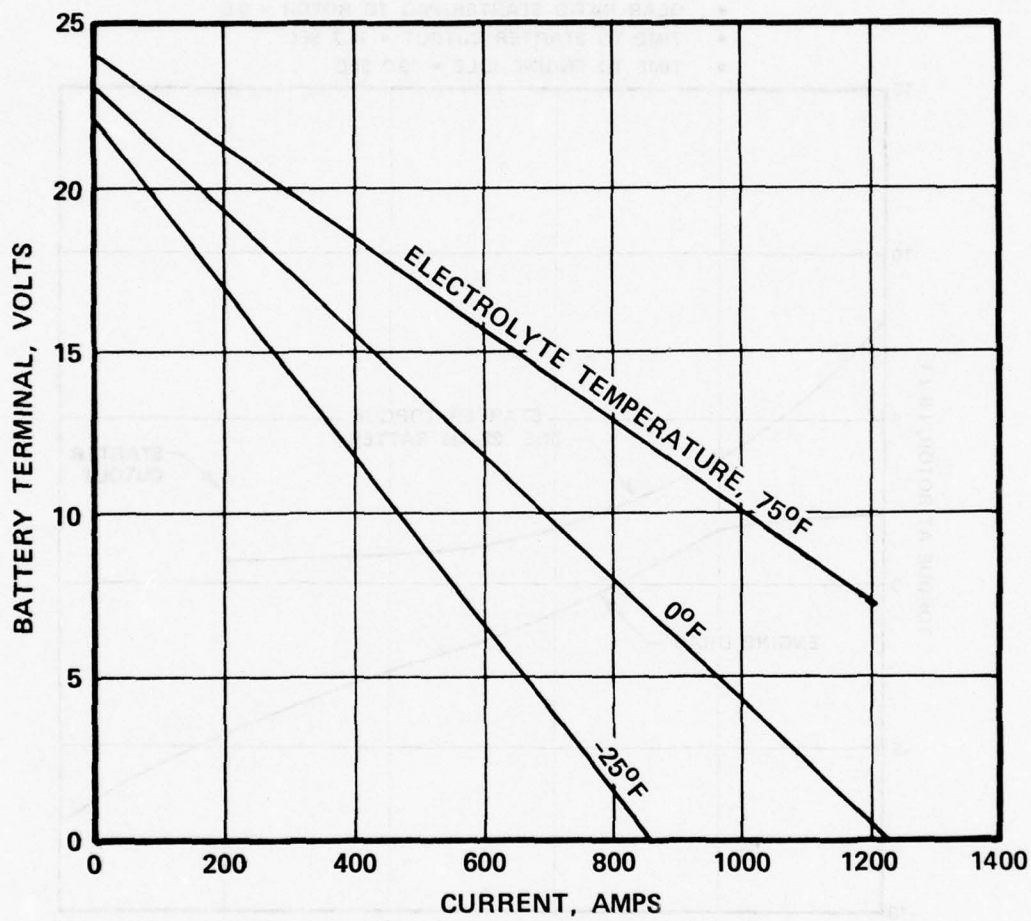

Figure 31. Discharge characteristics -
22-AH Ni-Cd battery.

SEA LEVEL -25°F

- AIRESEARCH STARTER MODEL 519802-4
- 0.002 Ω LINE RESISTANCE ASSUMED
- GEAR RATIO STARTER PAD TO ROTOR = 0.5
- TIME TO STARTER CUTOUT = 16.7 SEC
- TIME TO ENGINE IDLE = 19.0 SEC

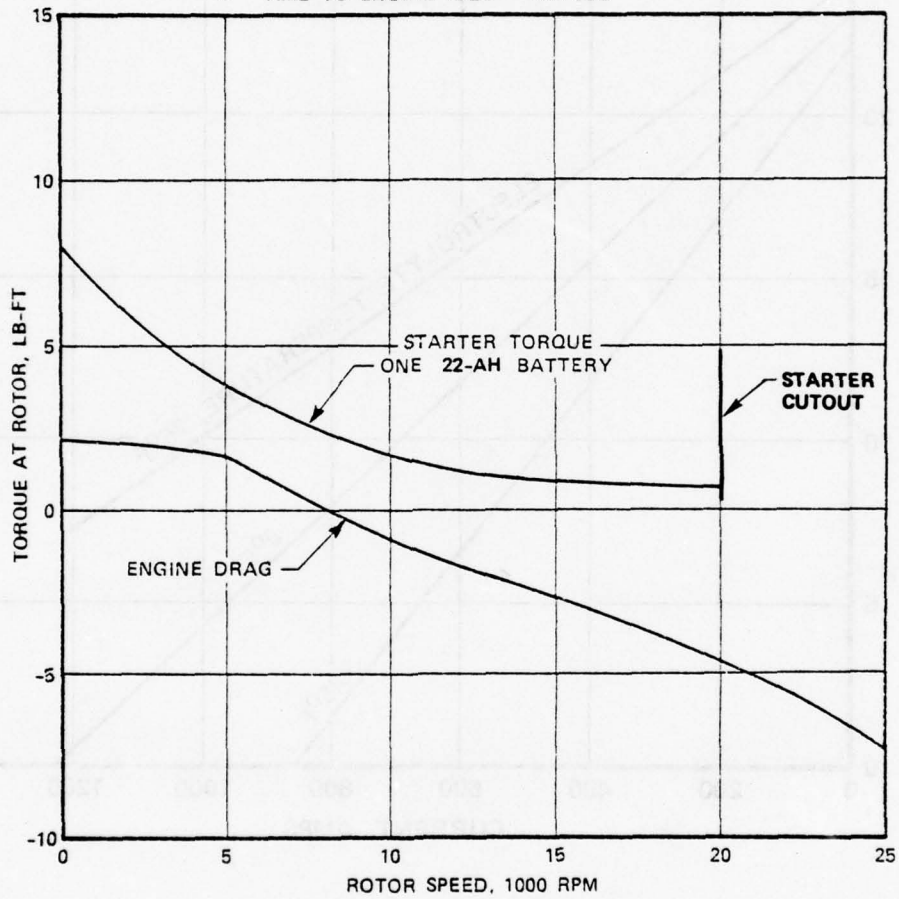

Figure 32. Electric start analysis - TSE1035 engine.

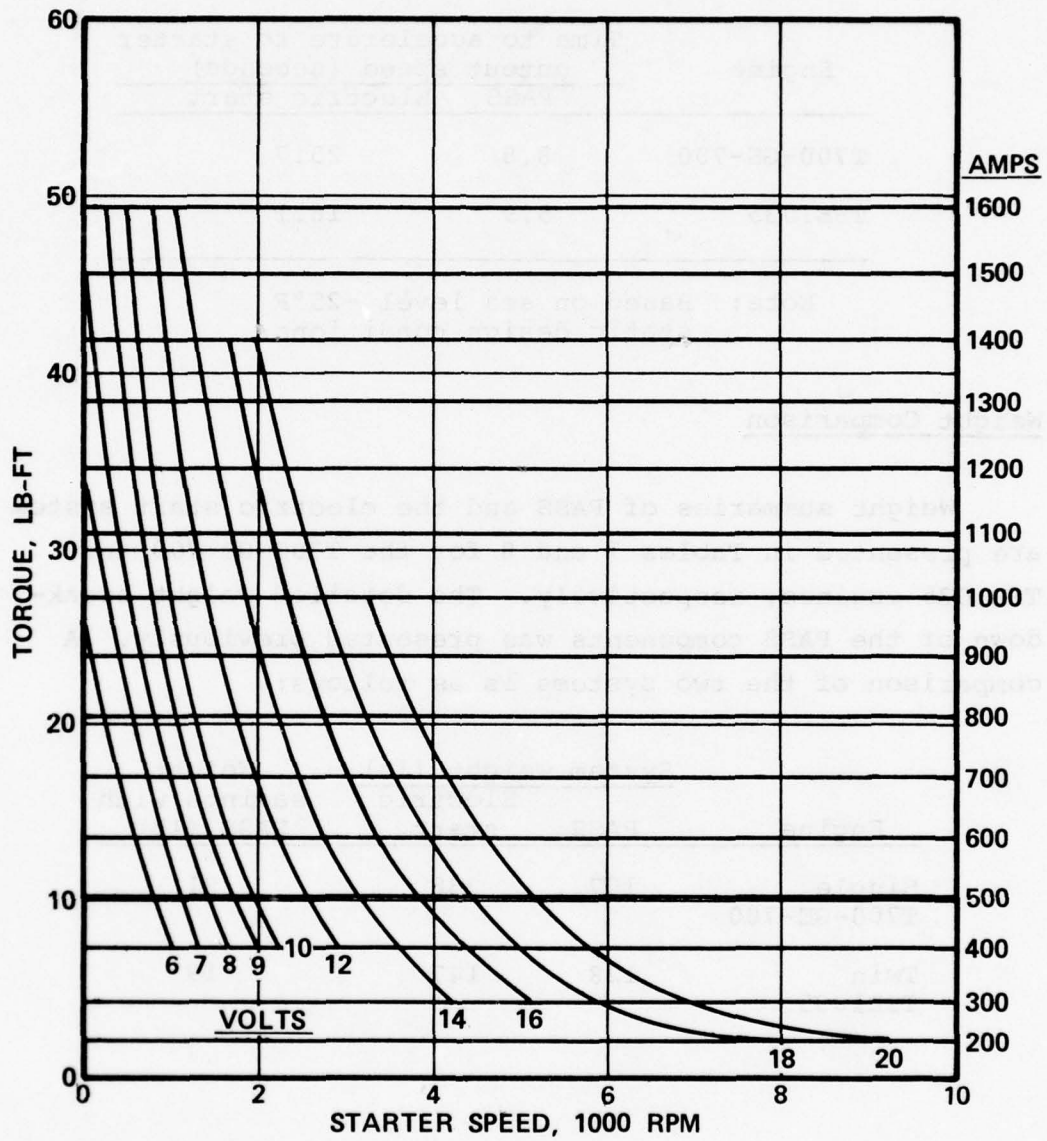

Figure 33. Generalized performance - AiResearch Model 519802-4 electric starter.

TABLE 6. PERFORMANCE COMPARISON PASS AND ELECTRIC START SYSTEM.

| Engine | Time to accelerate to starter cutout speed (seconds) | |
|-------------|--|----------------|
| | PASS | Electric start |
| T700-GE-700 | 8.8 | 25.7 |
| TSE1035 | 5.9 | 16.1 |

Note: Based on sea level -25°F static design conditions.

Weight Comparison

Weight summaries of PASS and the electric start system are presented in Tables 7 and 8 for the T700-GE-700 and TSE1035 engines, respectively. The detailed weight breakdown of the PASS components was presented previously. A comparison of the two systems is as follows:

| Engine | System weight (lb) | | Weight savings with PASS (lb) |
|--------------------|--------------------|----------------|-------------------------------|
| | PASS | Electric start | |
| Single T700-GE-700 | 157 | 238 | 81 |
| Twin TSE1035 | 128 | 147 | 19 |

TABLE 7. WEIGHT SUMMARY OF PASS AND ELECTRIC START, SINGLE T700-GE-700 ENGINE.

| | <u>Weight (lb)</u> |
|------------------------------|--------------------|
| <u>PASS</u> | |
| PASS Components | 110 |
| Pneumatic Lines and Fittings | 8 |
| Battery (13-AH) | 26 |
| Battery Conditioner | 10 |
| Battery Relay | <u>3</u> |
| TOTAL | 157 lb |
| <u>Electric Start</u> | |
| Starter | 30 |
| Start Relay | 3 |
| Batteries (3, 22-AH) | 165 |
| Battery Relay | 3 |
| Parallel/Series Relay (2) | 12 |
| Battery Conditioner | 10 |
| Wiring | <u>15</u> |
| TOTAL | 238 lb |

TABLE 8. WEIGHT SUMMARY OF PASS AND ELECTRIC START, TWIN TSE1035 ENGINES.

| | <u>Weight (lb)</u> |
|------------------------------|--------------------|
| <u>PASS</u> | |
| PASS Components | 75 |
| Pneumatic Lines and Fittings | 14 |
| Battery (13-AH) | 26 |
| Battery Conditioner | 10 |
| Battery Relay | <u>3</u> |
| TOTAL | 128 lb |
| <u>Electric Start</u> | |
| Starter (2) | 56 |
| Start Relay (2) | 6 |
| Battery (22-AH) | 55 |
| Battery Relay | 3 |
| Battery Conditioner | 10 |
| Wiring | <u>17</u> |
| TOTAL | 147 lb |

TASK II - MAINTENANCE

A maintainability analysis was conducted for both the PASS and the electric start system. The results of this analysis are summarized in Tables 9 through 12. A comparison of PASS and the electric start system is shown in Table 13.

For PASS, the required time to perform maintenance actions and inspection intervals was based on the history of similar AiResearch equipment. As shown in Tables 9 and 11, the deep cycle interval of the battery used with PASS is estimated to be six months compared to two months with the electric start system. This results from the improved charge/discharge cycling routine for the PASS battery. The battery used in the PASS start aircraft is normally subjected to shallow discharges when providing electrical power for cockpit instruments and lighting and power to actuate the PASS control valves. The batteries in the electric start aircraft experience a deep discharge cycle when starting the engines.

The performance of nickel-cadmium batteries (discharge voltage characteristics) is affected by the discharge cycling requirements. Repeated charge/discharge cycling of the battery results in a temporary degradation in the discharge voltage level that can be corrected by deep cycling. If the battery discharge cycle is relatively shallow, such as the battery used with PASS, the number of cycles to reach an unacceptable performance level will be very large. If the discharge cycle is deep, such as the battery used for electric starting, then the performance degrades more rapidly.

TABLE 9. SCHEDULED MAINTENANCE OF PRESSURIZED AIR START SYSTEM.

| Component | Task | Maintenance man-hours per 1000 flight hours | |
|------------|---------------------------|---|-------------|
| | | Single engine | Twin engine |
| Starter | 500-Hour Inspection | 0.33 | 0.66 |
| | a) Change oil | | |
| | b) Visual inspection | | |
| Compressor | 50-Hour Inspection | 1.66 | 1.66 |
| | a) Check oil level | | |
| | b) Visual inspection | | |
| | 500-Hour Inspection | 0.33 | 0.33 |
| | a) Change oil | | |
| | b) Visual inspection | | |
| Battery | 7-Day Inspection | 2.99 | 2.99 |
| | Deep cycle every 6 months | 2.80 | 2.80 |
| | TOTAL | 8.11 | 8.44 |

TABLE 10. UNSCHEDULED MAINTENANCE OF PRESSURIZED AIR START SYSTEM.

| Component | Maintenance man-hours per 1000 flight hours | | | |
|--|---|-----------|---------------------|-----------|
| | Single engine | | Twin engine | |
| | Organi- zational | Depot | Organi- zational | Depot |
| Primary Pressure Vessel/Control Manifold | 0.22 | 0.22 | 0.22 | 0.22 |
| Reserve Pressure Vessel/Control Manifold | 0.03 | -- | 0.03 | -- |
| Reserve Pressure Vessel Shutoff Valve | 0.02 | -- | 0.02 | -- |
| Starter | 0.02 | 0.19 | 0.04 | 0.38 |
| Starter Switch | 0.01 | -- | 0.01 | -- |
| Starter Shutoff Valve | -- | -- | 0.02 | -- |
| Starter Control Valve | 0.03 | 0.22 | 0.06 | 0.44 |
| Compressor | 0.16 | 0.52 | 0.16 | 0.52 |
| Compressor Shutoff Valve | 0.01 | -- | 0.01 | -- |
| Battery | 2.97 | -- | 2.97 | -- |
| Battery Charger | 0.17 | -- | 0.17 | -- |
| Battery Relay | <u>0.01</u> | <u>--</u> | <u>0.01</u> | <u>--</u> |
| TOTAL | 3.65 | 1.15 | 3.72 | 1.56 |

TABLE 11. SCHEDULED MAINTENANCE OF ELECTRIC START SYSTEM.

| Component | Task | Maintenance man-hours per 1000 flight hours | |
|-----------|---------------------------|---|-------------|
| | | Single engine | Twin engine |
| Starter | 200-Hour Inspection | 0.84 | 1.67 |
| Batteries | 7-Day Inspection | 6.01 | 2.99 |
| | Deep Cycle Every 2 Months | 12.60 | 6.30 |
| TOTAL | | 19.45 | 10.96 |

TABLE 12. UNSCHEDULED MAINTENANCE OF ELECTRIC START SYSTEM.

| Component | Maintenance man-hours per 1000 flight hours | | | |
|-----------------------|---|-----------|---------------------|-----------|
| | Single engine | | Twin engine | |
| | Organi- zational | Depot | Organi- zational | Depot |
| Starter | 0.17 | 0.51 | 0.34 | 1.02 |
| Start Relay | 0.01 | -- | 0.02 | -- |
| Batteries | 12.62 | -- | 4.21 | -- |
| Battery Relay | 0.01 | -- | 0.01 | -- |
| Parallel/Series Relay | 0.03 | -- | -- | -- |
| Battery Conditioner | <u>0.34</u> | <u>--</u> | <u>0.17</u> | <u>--</u> |
| TOTAL | 13.18 | 0.51 | 4.75 | 1.02 |

TABLE 13. MAINTENANCE COMPARISON - PASS AND ELECTRIC START SYSTEM.

| Task | Single Engine | | Twin engine | |
|----------------------------|--------------------------|---------------------------------------|--------------------------|---------------------------------------|
| | PASS* (man- hours) | Electric start* (man- hours) | PASS* (man- hours) | Electric start* (man- hours) |
| Scheduled Maintenance** | 8.11 | 19.45 | 8.44 | 10.96 |
| Unscheduled Maintenance | | | | |
| Organizational | 3.65 | 13.18 | 3.72 | 4.75 |
| Depot | <u>1.15</u> | <u>0.51</u> | <u>1.56</u> | <u>1.02</u> |
| TOTAL | 12.91 | 33.14 | 13.72 | 16.73 |

* Maintenance man-hours per 1000 flight hours.

** Scheduled maintenance data dependent on aircraft usage rate was based on 120 flight hours per month per aircraft.

For the electric start system, scheduled inspections and battery removal frequency for deep cycling was based on data supplied by Bell Helicopter for the AH-1J. The required time to perform maintenance actions was based on the history of similar AiResearch equipment.

The results of the maintenance task were used to conduct a life-cycle cost study which is presented under Task IV.

TASK III - RELIABILITY

A reliability analysis was conducted for the PASS and the electric start system components in order to predict the failure frequencies for unscheduled maintenance requirements discussed in Task II. A comparison of PASS and the electric start system is shown in Table 14.

TABLE 14. RELIABILITY COMPARISON - PASS AND ELECTRIC START SYSTEM.

| | | Failure rate per 1000 flight hours | Average system mean time between failures (MTBF) |
|------------------|-------------------|---------------------------------------|---|
| Single Engine | PASS | 1.774 | 564 |
| | Electric Start | 27.035 | 37 |
| Twin Engine | PASS | 2.094 | 478 |
| | Electric Start | 10.623 | 94 |

The projected reliability of the major components of PASS and the electric start system is shown in Tables 15 and 16, respectively.

TABLE 15. PROJECTED RELIABILITY OF
PRESSURIZED AIR START SYSTEM.

| Component | Failure rate per 1000 flight hours | |
|--|---------------------------------------|--------------|
| | Single engine | Twin engine |
| Primary Pressure Vessel/ Control Manifold | 0.356 | 0.356 |
| Reserve Pressure Vessel/ Control Manifold | 0.104 | 0.104 |
| Reserve Pressure Vessel Shutoff Valve | 0.040 | 0.040 |
| Starter | 0.115 | 0.230 |
| Starter Switch | 0.058 | 0.058 |
| Starter Shutoff Valve | -- | 0.080 |
| Starter Control Valve | 0.125 | 0.250 |
| Compressor | 0.200 | 0.200 |
| Compressor Shutoff Valve | 0.040 | 0.040 |
| Battery | 0.333 | 0.333 |
| Battery Conditioner | 0.333 | 0.333 |
| Battery Relay | <u>0.070</u> | <u>0.070</u> |
| TOTAL FAILURE RATE | 1.774 | 2.094 |

TABLE 16. PROJECTED RELIABILITY OF
ELECTRIC START SYSTEM.

| Component | Failure rate per 1000 flight hours | |
|-----------------------|---------------------------------------|--------------|
| | Single engine | Twin engine |
| Starter | 0.833 | 1.666 |
| Start Relay | 0.070 | 0.140 |
| Batteries | 25.242 | 8.414 |
| Battery Relay | 0.070 | 0.070 |
| Parallel/Series Relay | 0.140 | -- |
| Battery Conditioner | <u>0.680</u> | <u>0.333</u> |
| TOTAL FAILURE RATE | 27.035 | 10.623 |

For the PASS components, the reliability predictions were based on the operating history of similar AiResearch equipment and data supplied by component manufacturers. For the 13-AH battery and associated components used for systems checkout and initiation of the start, the reliability is based on battery manufacturer data for batteries with limited charge and discharge cycles.

For the electric start system, the battery reliability data was based on Navy Maintenance (3M) Data for the period of 1 January 1975 to 31 December 1976 for the AH-1J (67 aircraft), UH-1N (153 aircraft), UH-1E (89 aircraft), and UH-1H (14 aircraft). A total of 125,738 hours of operation were experienced during this period. This data was supplied by Bell Helicopter Company.

Bell also supplied starter/generator data for these aircraft; however, this data was not used since the comparison of PASS with electric starting was made for an aircraft that uses a separate rotor gearbox-driven generator. The electric starter data used for the analysis was based on the operating experience of AiResearch electric starters.

As shown in Table 16, the battery conditioner failure rate for the single engine (T700-GE-700) aircraft is much higher than the twin engine electric start aircraft or the PASS start aircraft. This results from the increased complexity of the conditioner to monitor the three batteries required for the T700 electric start compared to only one battery used in the other systems.

In addition to the reliability analysis, a failure modes and effects analysis was conducted for the pressurized air start system to indicate the operational capability after a given component failure. The results of this analysis are presented in Table 17.

TABLE 17. FAILURE MODES AND EFFECTS ANALYSIS OF PRESSURIZED AIR START SYSTEM.

| Component | Failure mode(s) | Failure effect(s) | Comments |
|------------------------------------|--|--|--|
| 1. Motor-Driven Compressor | Loss of output (mechanical failure) | Inability to recharge pressure vessel during flight. | Pressure vessel can be recharged through auxiliary fill port after landing. Reserve pressure vessel can be used for emergency or backup start. Cockpit pressure indicator light would remain off to warn of inadequate pressure. |
| 2. Compressor Motor Shutoff Valve | a. Failed closed | a. Inability to recharge pressure vessel during flight. | a. Same as Item 1. |
| | b. Failed open | b. Compressor will not shut down during flight when rated pressure is achieved. | b. Depending on main engine power setting (bleed air pressure level), compressor drive motor will stall at a compressor outlet pressure higher than rated pressure. If available bleed pressure is high (above 30 psig), burst disc will rupture to relieve pressure. System would not be operative until components are replaced. |
| 3. Check Valve | a. Failed open (fails to check) or excessive leakage | a. Inability to recharge pressure vessel from auxiliary fill port. | a. Leakage would occur when fitting on auxiliary fill port was removed. |
| | b. Failed closed | b. The pressure vessel cannot be filled from either the compressor or auxiliary fill port. | b. Due to the available pressure forces, this failure mode is remote. The compressor drive motor will stall when excessive pressure is reached in the compressor discharge line. |
| 4. Pressure Switch | a. Failed open | a. Inability to recharge pressure vessel during flight. | a. Same as Item 1. |
| | b. Failed closed | b. The compressor motor would not stop on reaching rated pressure. | b. Same as Item 2.b. |
| 5. Pressure Gauge (two per system) | Fails to indicate | No effect on system operation. Pressure indication is lost. | Indicator only. |

TABLE 17. FAILURE MODES AND EFFECTS ANALYSIS OF PRESSURIZED AIR START SYSTEM (CONTD).

| Component | Failure mode(s) | Failure effect(s) | Comments |
|--|---|---|---|
| 6. Pressure Vessel (two per system) | Leakage | The effect would depend upon the leakage rate and could result in only minor effect to a complete loss of air with loss of starting capability. | Reserve pressure vessel could be used for starting if leakage of primary is minor. |
| 7. Burst Disc (two per system) | a. Premature rupture of primary | a. Loss of air pressure. | a. Start system inoperative until disc is replaced. |
| | b. Premature rupture of reserve | b. Loss of reserve air pressure. | b. System operative but reserve capability lost. |
| | c. Fails to rupture at desired pressure | c. No effect on starting system operation unless preceded by a pressure switch failure. | c. Dual failures required before system operation is affected. |
| 8. Reserve Pressure Vessel Shutoff Valve | a. Failed closed | a. Loss of reserve start capability. | a. Normal operation can be made using primary pressure vessel. |
| | b. Failed open | b. No effect on system operation unless another component has failed resulting in system leakage. | b. Normal operation can be made; air is used from both pressure vessels during start. |
| 9. Regulator and Shutoff Valve | a. Failed closed | a. Loss of starting capability. | a. Pressure vessel must be depressurized, valve replaced, and pressure vessel recharged before engine can be started using PASS. |
| | b. Failed open | b. Starter would continue to operate at the end of start cycle until air pressure is depleted. | b. The starter is capable of free running until pressure is depleted. If compressor shutoff valve were activated to open, compressor would not charge pressure vessel since air would leak through starter. |
| | c. Excessive leakage | c. Loss of primary pressure vessel start capability. | c. Reserve pressure vessel can be used for start. |
| | d. Regulated pressure too high | d. Possible overtorque resulting in starter shear section failing. | d. Shear section failure depends on pressure level in pressure vessel at time of valve failure. |
| | e. Regulated pressure too low | e. Possible slow engine start or failure to start | e. Start can be aborted by opening cockpit start switch. |

TABLE 17. FAILURE MODES AND EFFECTS ANALYSIS OF PRESSURIZED AIR START SYSTEM (CONCLUDED).

| Component | Failure mode(s) | Failure effect(s) | Comments |
|--|---|--|---|
| 10. Air Turbine Starter | a. Loss of torque output (mechanical failure) | a. Loss of starting capability. | a. Starter must be replaced. |
| | b. Overrunning clutch slippage | b. Loss of starting capability. | b. Starter shear section will shear; upstream regulator and shutoff valve will close when starter turbine reaches cutout speed. Starter must be replaced. |
| | c. Overrunning clutch lockup | c. Engine will start as normal. | c. When starter cutout speed is reached, reverse torque on starter shaft disengages decoupler. Starter must be replaced before next start can be made. |
| | d. No signal from monopole speed sensor | d. Regulating and shutoff valve will remain open after start | d. The starter is capable of free running until air pressure is depleted. Opening cockpit start switch will close valve. |
| | e. Speed switch fails open | e. Regulating and shutoff valve will close before starter cutout is reached. | e. Switch failure can be overridden by holding cockpit start switch to avoid loss of engine start. |
| | f. Speed switch fails closed | f. Regulating and shutoff valve will remain open after start. | f. Same as Item 10.d. |
| 11. Starter Control Valve | a. Fails closed | a. Loss of starting capability from pneumatic ground cart. | a. Engine starts can be made using pressure vessels. |
| | b. Fails open | b. Starter would continue to operate at the end of start cycle. | b. Starter is capable of free running for short period of time using pneumatic ground cart. Ground cart can be disconnected or shut down. |
| | c. Regulated pressure too high | c. Possible overtorque resulting in starter shear section failing. | c. Shear section failure depends on level of pressure available from ground cart. |
| | d. Regulated pressure too low | d. Possible slow engine start or failure to start. | d. Start can be aborted by opening cockpit start switch. |
| 12. Starter Shutoff Valve (applicable to twin engine only) | a. Failed closed | a. Loss of starting capability using pressure vessel. | a. Cross-bleed or ground-cart starts can be made. |
| | b. Failed open | b. Starter would operate when start attempt was made on opposite engine using pressure vessel. | b. Same as 12.a. |

PHASE IV - LIFE-CYCLE COST INVESTIGATION

A ten-year life-cycle cost comparison of the electric start system and PASS is shown in Table 18.

TABLE 18. LIFE-CYCLE COST COMPARISON.

| | | Ten-year life-cycle cost (millions of 1977 dollars) |
|------------------------------|---------------------------|--|
| | Electric Start | 32.44 |
| Single Engine T700-GE-700 | PASS | <u>19.15</u> |
| | Cost Savings with PASS | 13.29 |
| | Electric Start | 31.60 |
| Twin Engine TSE1035 | PASS | <u>23.86</u> |
| | Cost Savings with PASS | 7.74 |
| | Electric Start | 31.60 |

Based on 700 aircraft at a usage rate of 120 flight hours per month.

A summary of the life-cycle cost data for each of the major parameters considered is shown in Tables 19 and 20 for an aircraft usage rate of 120 and 30 flight hours per month, respectively. The effect of aircraft usage rate on life-cycle cost is shown in Figures 34 and 35. As shown, the cost savings with PASS is reduced as the usage rate decreases.

A summary of the constants used in the life-cycle cost analysis is presented in Table 21.

TABLE 19. LIFE-CYCLE COST SUMMARY FOR 120 FLIGHT HOURS PER MONTH (1977 DOLLARS).

| Parameter | Single-engine aircraft | | Twin-engine aircraft | |
|--|------------------------|------------------------------|-----------------------|------------------------------|
| | Electric start system | Pressurized air start system | Electric start system | Pressurized air start system |
| <u>Acquisition Costs</u> | | | | |
| Start System Components | \$ 5,110,600 | \$ 7,350,000 | \$ 5,110,600 | \$ 9,870,000 |
| Development and Qualification | 100,000 | 300,000 | 100,000 | 300,000 |
| <u>Operating Costs</u> | | | | |
| Scheduled Maintenance Labor Cost | 2,350,975 | 980,986 | 1,324,765 | 1,020,902 |
| Unscheduled Maintenance Labor Cost | 1,678,561 | 631,613 | 742,643 | 707,858 |
| Labor Cost for Maintenance, Supply, and Transportation Records and Forms | 1,602,375 | 105,145 | 629,629 | 127,549 |
| Cost of Base and Depot Consumable Materials During Maintenance | 784,462 | 371,254 | 430,146 | 419,761 |
| Parts Cost to Replace/Repair Components | 20,815,513 | 9,413,754 | 23,261,448 | 11,413,374 |
| Total Life-Cycle Cost: | \$32,442,486 | \$19,152,752 | \$31,599,231 | \$23,859,444 |

Based on 700 aircraft at a usage rate of 120 flight hours per month for 10 years.

TABLE 20. LIFE CYCLE COST SUMMARY FOR 30 FLIGHT HOURS PER MONTH (1977 DOLLARS).

| Parameter | Single-engine aircraft | | Twin-engine aircraft | |
|--|------------------------|------------------------------|-----------------------|------------------------------|
| | Electric start system | Pressurized air start system | Electric start system | Pressurized air start system |
| <u>Acquisition Costs</u> | | | | |
| Start System Components | \$ 5,110,600 | \$ 7,350,000 | \$ 5,110,600 | \$ 9,870,000 |
| Development and Qualification | 100,000 | 300,000 | 100,000 | 300,000 |
| <u>Operating Costs</u> | | | | |
| Scheduled Maintenance Labor Cost | 2,273,393 | 770,213 | 1,167,118 | 780,192 |
| Unscheduled Maintenance Labor Cost | 419,640 | 157,903 | 185,661 | 176,965 |
| Labor Cost for Maintenance, Supply, and Transportation Records and Forms | 400,594 | 26,286 | 157,407 | 31,887 |
| Cost of Base and Depot Consumable Materials During Maintenance | 196,116 | 92,814 | 107,537 | 104,940 |
| Parts Cost to Replace/Repair Components | 9,361,878 | 2,815,439 | 7,201,362 | 3,315,344 |
| Total Life-Cycle Cost: | \$17,862,221 | \$11,512,655 | \$14,029,685 | \$14,579,328 |

Based on 700 aircraft at a usage rate of 30 flight hours per month for 10 years.

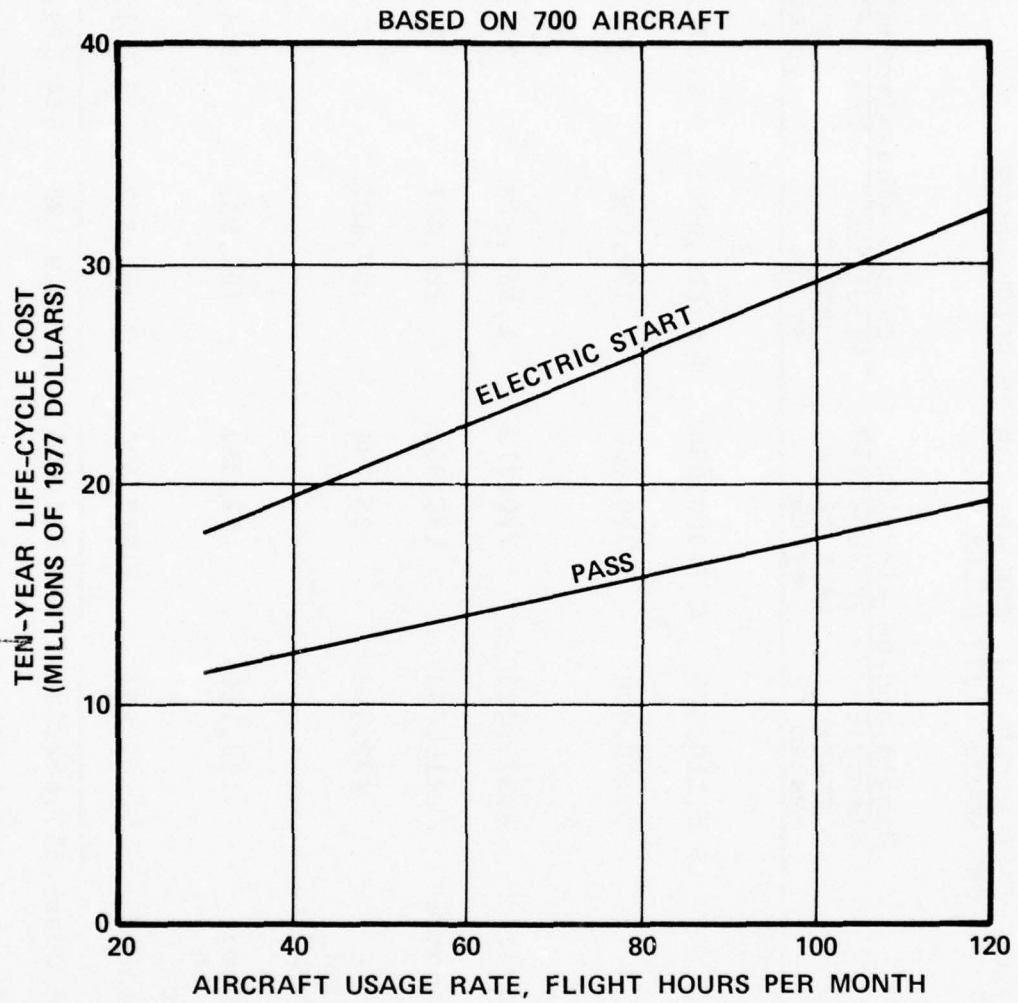

Figure 34. Life-cycle cost versus aircraft usage rate for single T700-GE-700 engine.

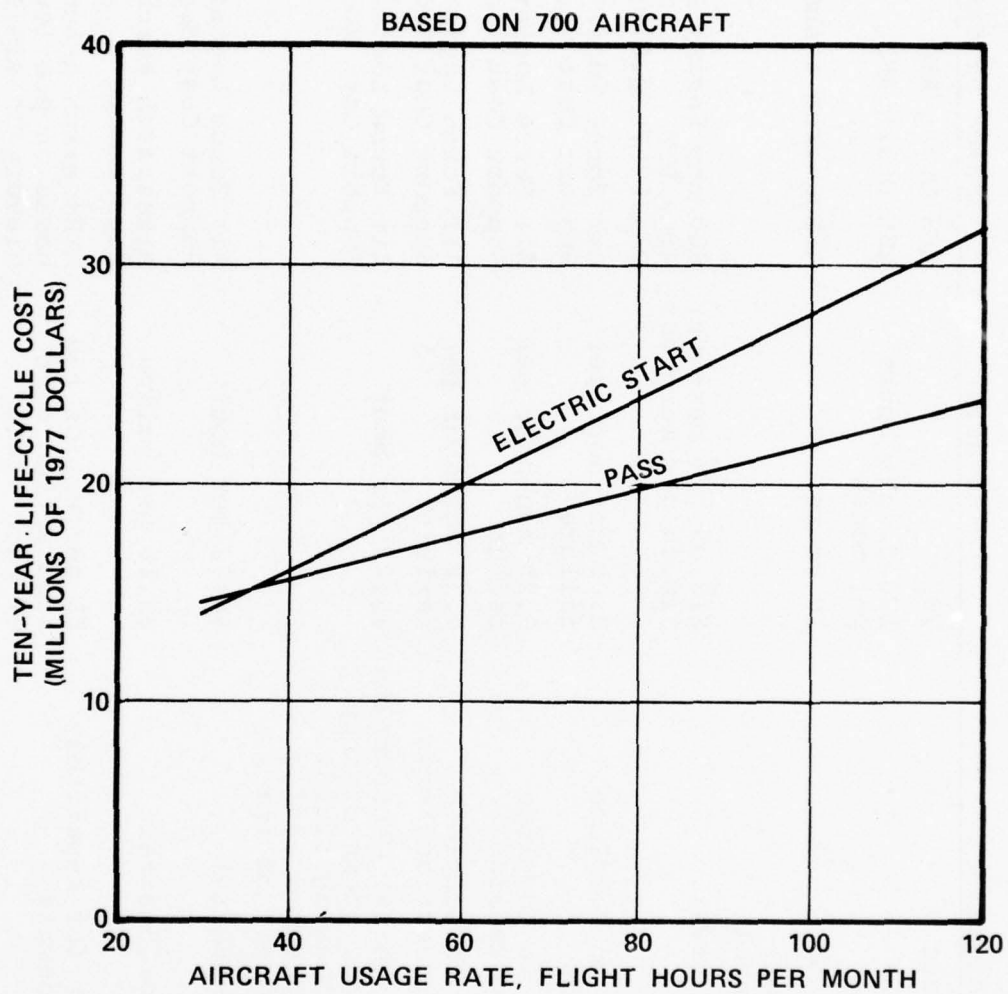

Figure 35. Life-cycle cost versus aircraft usage rate for twin TSE1035 engines.

TABLE 21. SUMMARY OF CONSTANTS USED IN LIFE-CYCLE COST ANALYSIS.

| Constant | Value used | Source of data |
|--|---|---|
| Quantity of Aircraft | 700 | ASH Draft RFQ |
| Aircraft Usage Rate | 120 flight hours per month | ASH Draft RFQ |
| Life-Cycle Cost Time | 10 years | AiResearch assumption |
| Army Labor Rate for Maintenance Personnel | | |
| • Organizational Level | \$12.00 per man-hour | 800 shp Engine ATDE |
| • Depot Level | \$16.40 per man-hour | Army RFQ DAAJ02-76-Q-0144 |
| Average Man-hours to Complete Maintenance Records | 0.08 man-hour per failure | Air Force Logistics Support Cost Model |
| Average Man-hours to Complete Supply Transaction Records | 0.25 man-hour per failure | Air Force Logistics Support Cost Model |
| Average Man-hours to Complete Transportation Transaction Forms | 0.16 man-hour per failure | Air Force Logistics Support Cost Model |
| Base Consumable Material Consumption Rate (includes minor items of supply [washers, rags, cleaning fluid, etc.] which are consumed during maintenance and repair of items) | \$2.28 per hour | Air Force Logistics Support Cost Model |
| Depot Consumable Material Consumption Rate | \$6.72 per hour | Air Force Logistics Support Cost Model |
| Lubricating Oil for Starter and Compressor | \$9.16 per gallon | AiResearch Purchasing Department |
| Average Parts Cost for Repairable Start System Components | 50 percent of the acquisition cost of each start system component | AiResearch assumption based on previous history of similar components |

In addition to the quantitative comparison of the life-cycle cost of the electric start system, a qualitative comparison has been made for parameters that would require a mission analysis of the aircraft, airframe company evaluation, or U.S. Army evaluation. This comparison is shown in Table 22. Of the parameters shown in Table 22, it is estimated that the reduction in fuel cost per mission due to equipment weight savings with PASS would be the highest dollar value savings.

Although the electric start system will result in less fuel per mission due to the power extraction from the main engine to recharge the system, the recharge time would be less than 7 percent of the mission time assuming a 2.5-hour mission.

LIFE-CYCLE COST EQUATIONS AND VARIABLES

A definition of the life-cycle cost equations used in the analysis and the assumptions used in calculating the variables is presented in the following discussion.

Acquisition Cost:

$$\text{Cost} = (\text{cost of start system components per aircraft}) \times 700 (\text{aircraft}) + (\text{nonrecurring cost for development and qualification of start system})$$

The cost of start system components and non-recurring costs is based on the purchase price from the start system manufacturer by the U.S. Army or helicopter manufacturer.

AD-A051 967

AIRESEARCH MFG CO OF ARIZONA PHOENIX
EVALUATION OF A PRESSURIZED AIR START SYSTEM FOR ADVANCED ARMY --ETC(U)
NOV 77 J A RHODEN
41-1810A

F/G 21/5

DAAJ02-77-C-0007

NL

USAAMRDL-TR-77-46

UNCLASSIFIED

2 OF 2

AD
A051 967



END
DATE
FILMED
5-78
DDC

TABLE 22. QUALITATIVE COMPARISON OF ADDITIONAL LIFE-CYCLE COST PARAMETERS.

| Parameter | Electric start system | Pressurized air start system |
|--|--|---|
| <u>Parameters Usually With Higher Dollar Value in Weapon System Life-Cycle Cost</u> | | |
| ● Reduction in fuel cost per mission due to equipment weight savings | - | Lowest |
| ● Reduction in aircraft acquisition cost due to equipment weight savings | - | Lowest |
| ● Reduction in fuel cost per mission due to power extraction from main engine to recharge start system | Lowest | - |
| <u>Parameters Usually with Lower Dollar Value in Weapon System Life-Cycle Cost</u> | | |
| ● Initial cost to introduce a new line item into Army inventory | Lowest | - |
| ● Packing and shipping costs | Equal (fewer components, heavier weight) | Equal (more components, lighter weight) |
| ● Cost of base and depot facilities and test equipment for maintenance of system | Lowest | - |

Scheduled Maintenance Labor Cost:

Cost = (scheduled maintenance man-hours per flight hour) x (flight hours in 10 years per aircraft) x (number of aircraft) x (dollars per man-hour)

Unscheduled Maintenance Labor Cost:

Cost = (unscheduled maintenance man-hours per flight hour) x (flight hours in 10 years per aircraft) x (number of aircraft) x (dollars per man-hour)

The above equation is applicable to maintenance labor for both organizational and depot maintenance.

Labor Cost for Maintenance, Supply, and Transportation Records and Forms:

Cost = (man-hours per failure) x (failure per flight hour) x (flight hours in 10 years per aircraft) x (number of aircraft) x (dollars per man-hour)

The man-hours per failure for each of the categories are shown in Table 21.

Cost of Base and Depot Consumable Materials During Maintenance:

Cost = (consumption rate, dollars per hour) x (hours to repair per failure) x (failures per flight hour) x (flight hours in 10 years per aircraft) x (number of aircraft)

The consumption rate for base and depot levels is shown in Table 21. The cost of lubricating oil for the PASS starter and compressor is included in this parameter.

Cost = (replacement or average repair cost, dollars) x (failure per flight hour) x (flight hours in 10 years per aircraft) x (number of aircraft)

The maintenance procedure for disposition of failed components is shown in Tables 23 and 24 for the electric start and PASS, respectively. For components to be replaced, the replacement cost was assumed to be the acquisition cost of that component. For components to be repaired, the average repair cost per failure was assumed to be 50 percent of the initial acquisition cost of that component except for batteries.

The predominant repair cost for batteries is the replacement of individual cells. The data used in estimating the battery repair costs is summarized in Table 25.

TABLE 23. DISPOSITION OF FAILED COMPONENTS
OF ELECTRIC START SYSTEM.

| <u>Failed component</u> | <u>Maintenance procedure</u> |
|-------------------------|----------------------------------|
| Starter | Repair |
| Start Relay | Replace |
| Battery | Repair |
| Battery Relay | Replace |
| Parallel/Series Relay | Replace |
| Battery Conditioner | Repair |

TABLE 24. DISPOSITION OF FAILED COMPONENTS OF PRESSURIZED AIR START SYSTEM.

| <u>Failed component</u> | <u>Maintenance procedure</u> |
|---------------------------------------|------------------------------|
| Pressure Vessel | Replace |
| Ground Service Valve | Replace |
| Burst Disc | Replace |
| Pressure Gauge | Replace |
| Check Valve | Replace |
| Pressure Switch | Replace |
| Pressure Regulator and Shutoff Valve | Repair |
| Reserve Pressure Vessel Shutoff Valve | Replace |
| Starter | Repair |
| Starter Shutoff Valve | Replace |
| Starter Control Valve | Repair |
| Compressor | Repair |
| Compressor Shutoff Valve | Replace |
| Battery | Repair |
| Battery Relay | Replace |
| Battery Conditioner | Repair |

TABLE 25. BATTERY REPAIR COST DATA.

| Variable | Value | Source of Data |
|---|------------------|--|
| Deep cycle frequency when used for electrical systems checkout and main engine starting | Every two months | Bell Helicopter estimate based on AH-1J data |
| Deep cycle frequency when used for electrical systems checkout | Every six months | AiResearch estimate based on battery manufacturer's data |
| Average number of cells replaced per battery per deep cycle | 1.0 | AiResearch estimate based on battery maintenance records from AiResearch repair facility |
| Cell replacement cost | \$44 per cell | Battery manufacturer's data |

TASK V - LOGISTICS

The application of current and planned Army ground support equipment and special requirements for operating the pressurized air start system has been investigated. The ground support equipment would be used in the event of a failure of the on-board equipment that required recharging the system or as a backup starting capability to the on-board storage system.

PNEUMATIC GROUND CARTS

The pneumatic ground cart would be used to supply compressed air to the low-pressure portion of the air turbine starter for main engine starting. This unit would be used for:

- Backup starting in the event of a failure of the PASS air delivery system.
- Maintenance of the engine or other aircraft systems that required main engine starting or motoring.

Starting analysis has been conducted with two pneumatic ground carts. These include the USAF Type A/M32A-60A and the mobile, multiple-output ground power unit (GPU) that AiResearch has been studying under Contract DAAJ02-76-C-0042 for the U.S. Army Air Mobility Research and Development Laboratory.

The A/M32A-60A is a self-contained, self-propelled power source that includes a gas turbine compressor and power unit. This unit (shown in Figure 36) provides compressed air for main engine starting or environmental control system operation and electrical power (ac and dc).

The Army GPU is a self-contained, self-propelled power source that includes a gas turbine compressor and power unit. This unit (design from AiResearch study) is shown in Figure 37. The GPU provides compressed air for main engine starting or environmental control system operation, hydraulic power, and ac electrical power. This unit is intended to meet the requirements of the Advanced Attack Helicopter (AAH), the Utility Tactical Transport Aircraft System (UTTAS), the modernized medium (CH-47D) helicopters, and future advanced helicopters.

A starting analysis has been conducted for both the T700-GE-700 engine and the TSE1035 engine with these ground carts. The results of this analysis are presented in Tables 26 and 27.

BACKUP RECHARGE EQUIPMENT

The on-board pressure vessels can be recharged in the event of leakage or a failure of the on-board compressor by connecting a portable ground compressor unit, portable high pressure nitrogen or air bottle, or by incorporating a hand-pump in the design of the on-board compressor. The results of the evaluation of these methods are presented in the following paragraphs.

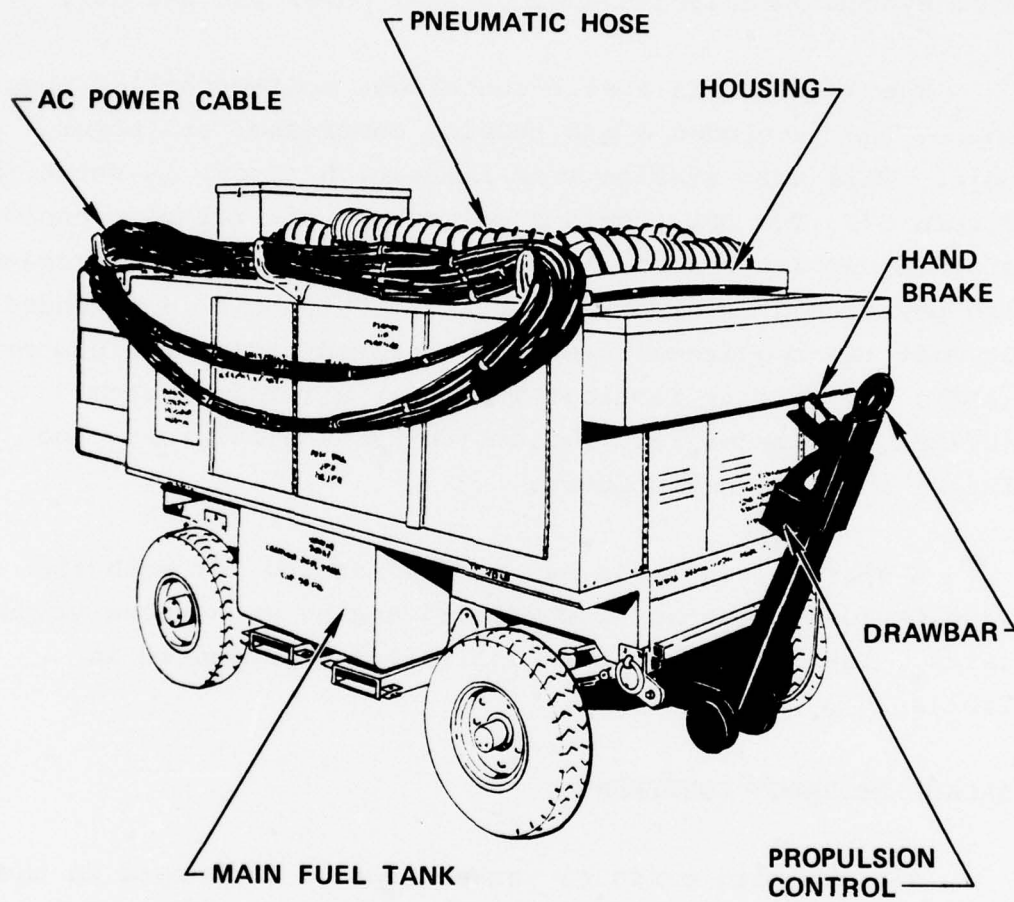

Figure 36. Type A/M32A-60A ground power unit.

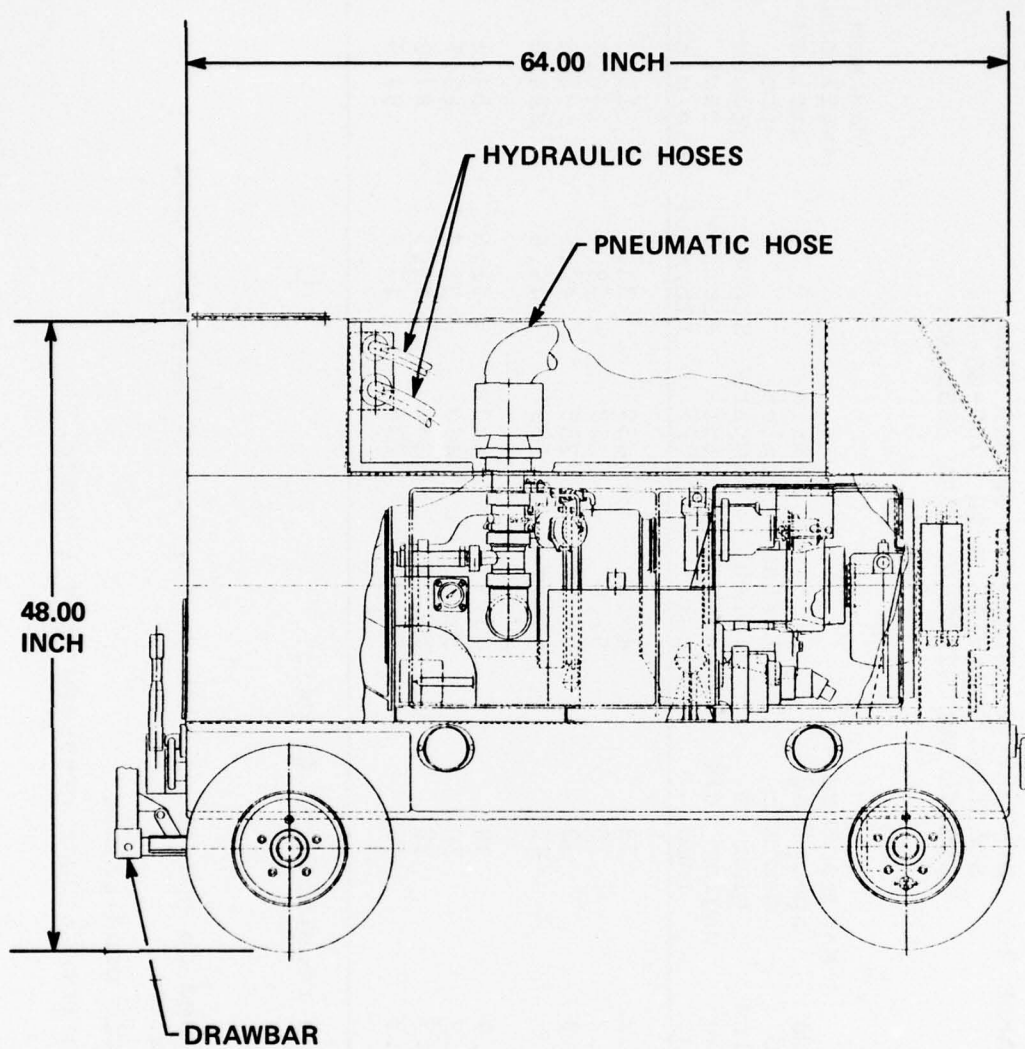

Figure 37. Ground power unit, gas turbine powered.

TABLE 26. SUMMARY OF PNEUMATIC GROUND CART STARTING ANALYSIS WITH T700-GE-700 ENGINE AND STARTER, PART 3505380.

| Ground cart | Ambient temperature (°F) | Time to engine idle (sec) | Manufacturer's specified maximum time to engine idle (sec) | Starter inlet pressure (psia) | Starter inlet temperature (°F) | Starter airflow (lb/min) | Maximum available airflow from ground cart (lb/min) |
|-------------|--------------------------|---------------------------|--|-------------------------------|--------------------------------|--------------------------|---|
| A/M32A-60A | 125 | 18.3 | 38 | 48.1 | 430 | 33.7 | 115.0 |
| | 59 | 17.3 | 30 | 52.9 | 357 | 38.7 | 146.0 |
| | -25 | 18.9 | 38 | 54.7* | 255 | 42.8 | 192.0 |
| | -65 | 20.5 | 45 | 54.7* | 199 | 44.6 | 224.0 |
| Army GPU | 125 | 18.9 | 38 | 46.3 | 470 | 31.8 | 54.5 |
| | 59 | 17.8 | 30 | 51.5 | 400 | 36.7 | 69.5 |
| | -25 | 18.7 | 38 | 54.7* | 300 | 41.5 | 87.0 |
| | -65 | 20.3 | 45 | 54.7* | 238 | 43.3 | 94.5 |

* Starter control valve regulated to 40 psig.

Notes:

1. Performance based on operation with 30 ft, 3.5-in.-diameter hose on ground cart.
2. Sea level static conditions.
3. Five percent aircraft duct pressure loss assumed.

TABLE 27. SUMMARY OF PNEUMATIC GROUND CART STARTING ANALYSIS WITH TSE1035 ENGINE AND STARTER, PART 3505386.

| Ground cart | Ambient temperature (°F) | Time to engine idle (sec) | Manufacturer's specified maximum time to engine idle (sec) | Starter inlet pressure (psia) | Starter inlet temperature (°F) | Starter airflow (lb/min) | Maximum available airflow from ground cart (lb/min) |
|-------------|--------------------------|---------------------------|--|-------------------------------|--------------------------------|--------------------------|---|
| A/M32A-60A | 125 | 9.2 | Not specified | 48.1 | 430 | 26.2 | 115.0 |
| | 59 | 7.9 | ↓ | 52.9 | 357 | 30.1 | 146.0 |
| | -25 | 7.6 | | 54.7* | 255 | 33.3 | 192.0 |
| | -65 | 7.0 | | 54.7* | 199 | 34.7 | 224.0 |
| Army GPU | 125 | 9.5 | | 46.3 | 470 | 24.7 | 54.5 |
| | 59 | 8.1 | 51.5 | 400 | 28.5 | 69.5 | |
| | -25 | 7.5 | 54.7* | 300 | 32.3 | 87.0 | |
| | -65 | 7.0 | 54.7* | 238 | 33.7 | 94.5 | |

* Starter control valve regulated to 40 psig.

Notes:

1. Performance based on operation with 30 ft, 3.5-in.-diameter hose on ground cart.
2. Sea level static conditions.
3. Five percent aircraft duct pressure loss assumed.

GROUND COMPRESSOR UNITS

A survey was made of current portable ground compressor units that would be applicable to PASS. Available units include:

| Unit | Applicable military specification | Federal stock number | Current application |
|------------------------------|-----------------------------------|----------------------|-------------------------|
| 3500-psi, 15-scfm compressor | MIL-C-52037 | 4310-624-3213 | OV-1 |
| 3500-psi 4-scfm compressor | MIL-C-52477 | 4310-878-7969 | CH-47 CH-54 U-21S |

The 15-scfm unit is available in both skid-mounted and wheel-mounted configurations and is driven by either a gasoline engine or an electric motor. The 4-scfm unit is wheel mounted and powered by a gasoline engine.

An analysis of the PASS recharge characteristics when operated with these compressors is shown in Figures 38 and 39. Figure 38 shows the required time to recharge the PASS pressure vessel with the MIL-C-42037 compressor (15 scfm at 3500 psig). Data are shown for both the T700-GE-700 engine system which uses a 3400-cu-in. pressure vessel and the TSE1035 engine which uses a 1000-cu-in. pressure vessel. Figure 39 shows the same data when operated with the lower capacity MIL-C-52477 compressor (4 scfm at 3500 psig).

NOTES:

1. SEA LEVEL OPERATION
2. COMPRESSOR AIRFLOW = 15 SCFM
3. — T700-GE-700 ENGINE
-- TSE1035 ENGINE

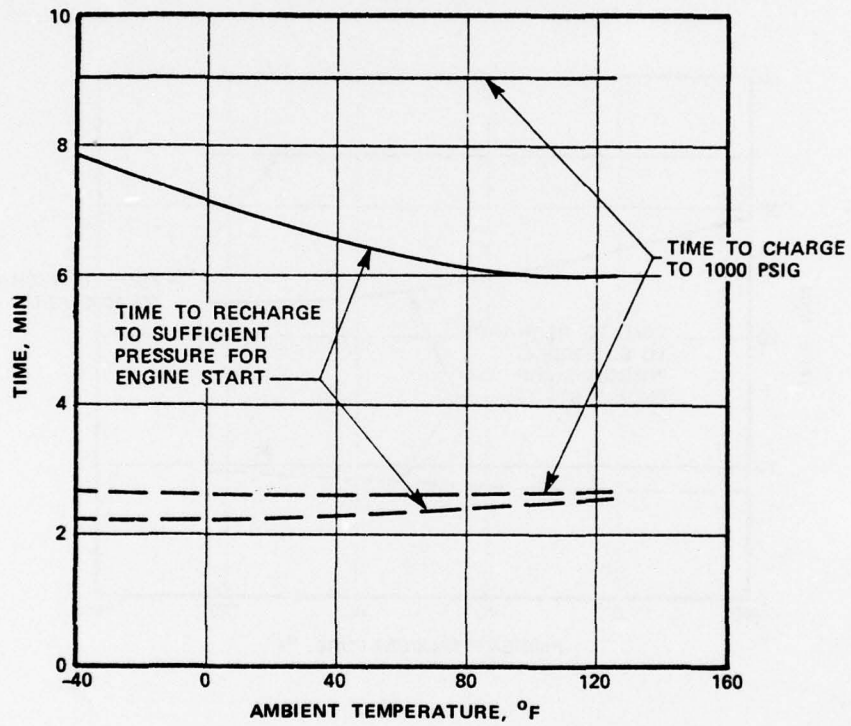

Figure 38. PASS recharge characteristics with MIL-C-52037 compressor.

- NOTES:
1. SEA LEVEL OPERATION
2. COMPRESSOR AIRFLOW = 4 SCFM
3. — T700-GE-700 ENGINE
 -- TSE1035 ENGINE

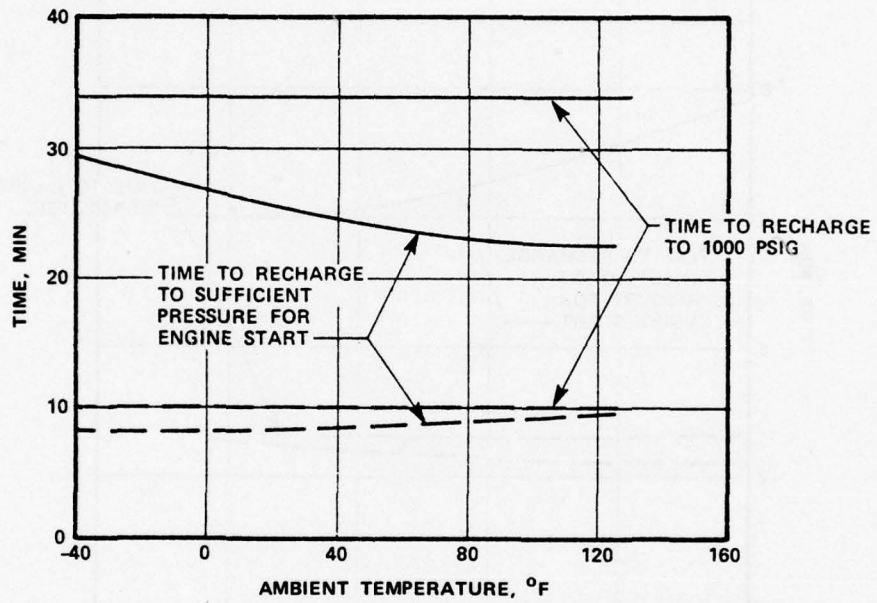

Figure 39. PASS recharge characteristics with MIL-C-52477 compressor.

PORTABLE GAS SERVICING UNITS

Portable gas servicing units that would be applicable to recharging the on-board pressure vessel include:

| Type | Federal stock number | Pressure rating |
|----------|----------------------|-----------------|
| GSU-40/E | 1190-773-1758CM | 3500 psi |
| MD-1 | 2330-507-9835 | 3500 psi |

Servicing capability of these units for the pressurized air start system for both the T700-GE-700 and TSE1035 engines is shown in Table 28.

TABLE 28. PASS RECHARGE CAPABILITY WITH PORTABLE GAS SERVICING UNITS

| Type servicing unit | Number of PASS recharges without recharging ground servicing unit | |
|---------------------|---|----------------|
| | T700-GE-700 engine | TSE1035 engine |
| GSU-40/E | 1 | 6 |
| MD-1 | 20 | 70 |

HAND CRANK WITH ON-BOARD COMPRESSOR

The feasibility of using a hand crank with the on-board compressor for backup recharge capability was investigated. This arrangement would require modifying the compressor design to incorporate a drive attachment for the crank and reduction gearing (130:1 gear ratio) from the compressor shaft to the crank attachment. These modifications would add approximately five pounds to the weight of the compressor.

The assumed cranking capability of an average man is shown in Figure 40. These data were generated by Boeing Vertol during a previous study of a hand-cranked compressor on board the YCH-47D helicopter. Using the cranking horsepower-time relationship of Figure 40, the required recharge time is as follows:

| Engine | Pressure vessel size (cu in.) | Cranking time* (min) | Number of men required** |
|-------------|-------------------------------|----------------------|--------------------------|
| T700-GE-700 | 3400 | 63.4 | 6 |
| TSE1035 | 1000 | 24.2 | 2 |

* Sea level standard day conditions.

** Assume each man cranks 10 to 12 minutes.

NOTES:

1. TWO-HANDED CRANK, WAIST HIGH
2. CRANK RADIUS, 12 IN.
3. AVERAGE SPEED = 30 REV. PER MIN

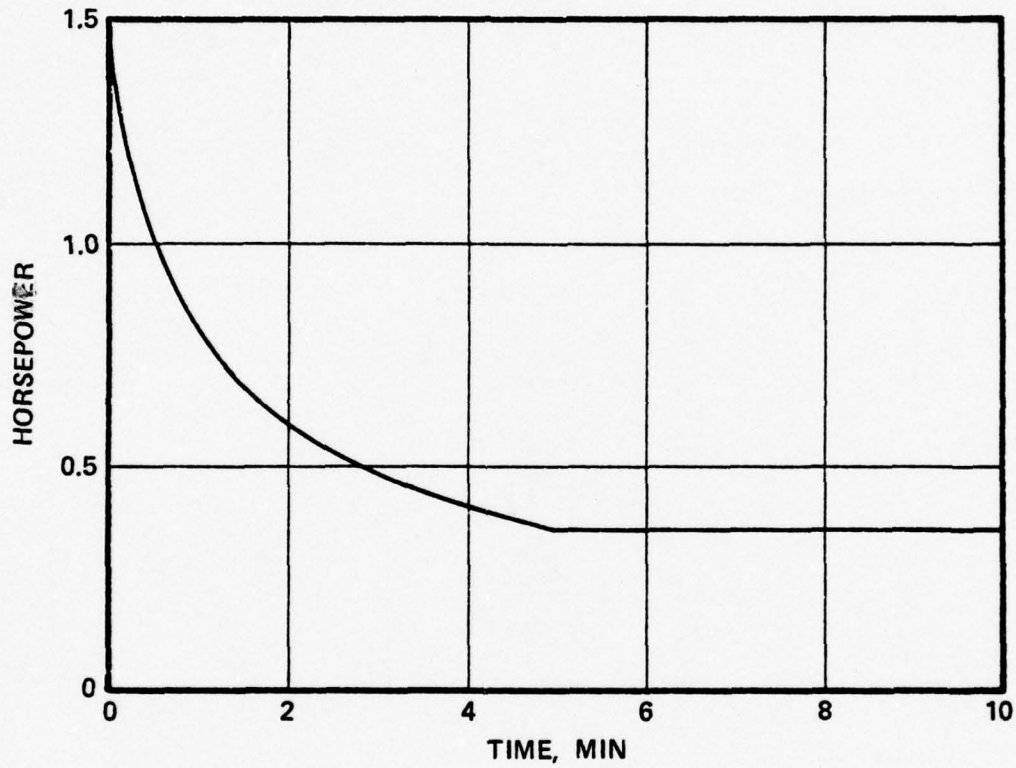
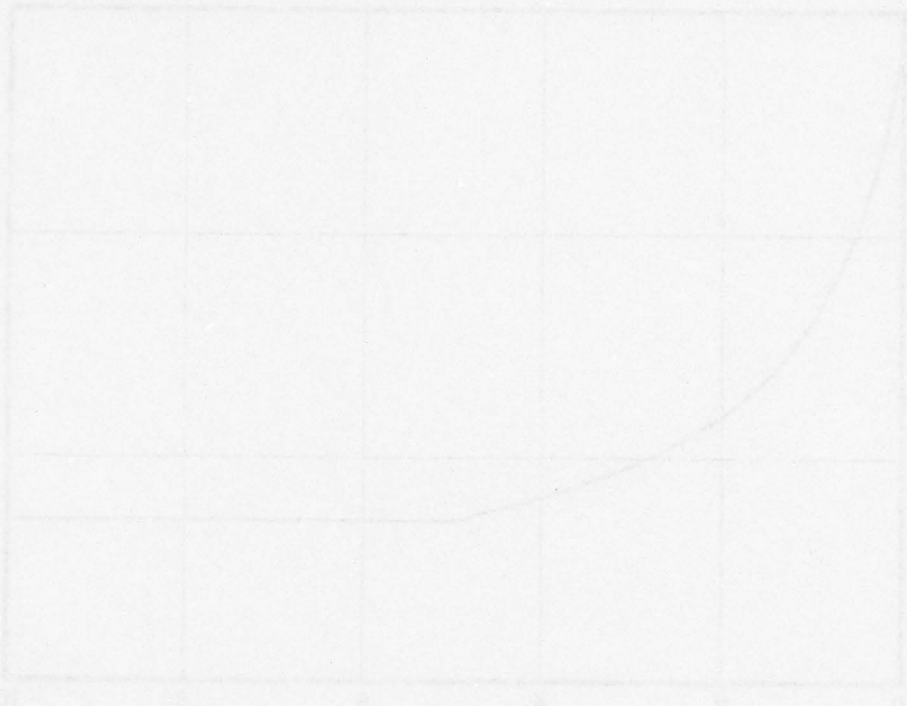

Figure 40. Estimated cranking capability, average man.

The relatively long time and the number of men required for recharge of the T700-GE-700 engine system would probably preclude incorporating this provision compared to attaching a portable ground compressor or gas servicing unit. For the TSE1035 engine, the concept would be feasible depending on the trade-off of the added weight to the aircraft.



TASK VI - VULNERABILITY

An analysis was conducted to determine the effect of ballistic impact on the operation of the start system and the effect on other aircraft systems. A summary of this analysis is presented in Table 29. For this analysis, it was assumed that the ballistic impact caused sufficient damage to the component to result in leakage of the working fluid (air) or mechanical failure.

The most vulnerable components in the PASS to ballistic impact are the pressure vessels, due to their relatively large exposed area. When impacted, the pressure vessels will not fragment and cause secondary damage to other components if they are fabricated from glass-filament-wound composites. The results of the gunfire test using a tumbling 0.30 caliber projectile and filament-wound pressure vessels are shown in Figure 41. The 1100-cu-in. pressure vessel was charged to 3000 psi for the test and the 514-cu-in. unit was charged to 2200 psi. The fiber wrap for the 1100-cu-in. unit is Kevlar-49 and for the 514-cu-in. unit it is S-Glass. Both units have a seamless 6061 aluminum liner.

To minimize the effect of ballistic impact on the start system operation, the primary pressure vessel should be installed in a location in the aircraft where maximum shielding is available. Loss of the primary unit results in loss of starting capability. Loss of the reserve unit results in loss of the backup capability only.

TABLE 29. BALLISTIC IMPACT ANALYSIS, PRESSURIZED AIR START SYSTEM.

| Component impacted | Effect on start system operation | Effect on other aircraft systems |
|---|---|--|
| 1. Motor-Driven Compressor | Inability to recharge pressure vessel | Continuous usage of bleed air if impact occurs before pressure vessel is charged to rated pressure |
| 2. Compressor Motor Shutoff Valve | Inability to shut down compressor when rated pressure is achieved. If overpressure condition occurs, burst disc will rupture to relieve pressure. | Continuous usage of bleed air |
| 3. Primary Pressure Vessel Including Control Manifold Components | Inability to recharge pressure vessel and loss of starting capability | Continuous usage of bleed air if impact occurs before pressure vessel is charged to rated pressure |
| 4. Reserve Pressure Vessel | No effect on starting capability using primary pressure vessel. Loss of backup capability of reserve pressure vessel. | None |
| 5. Air Turbine Starter | Loss of starting capability | None |
| 6. High-Pressure Starter Supply Line | Loss of starting capability | None |
| 7. Reserve Pressure Vessel to Primary Pressure Vessel Supply Line | Loss of starting capability | Compressor will start resulting in continuous usage of bleed air |
| 8. Compressor Discharge Line | Inability to recharge pressure vessel | Continuous usage of bleed air if impact occurs before pressure vessel is charged to rated pressure |
| 9. Engine Bleed-Air Line to Compressor | Inability to recharge pressure vessel | Continuous usage of bleed air |



514 CU IN. PRESSURE VESSEL



1100 CU IN. PRESSURE VESSEL

Figure 41. Filament-wound pressure vessel after 0.30 caliber gunfire test.

A comparison of the area exposed to ballistic impact for an electric start system and a PASS is shown in Table 30. As shown, the electric start system has less than half the exposed area of the PASS. This results primarily from the relatively high density of the batteries compared to the relatively low-pressure rating of pressure vessels, resulting in large volumes. This disadvantage could be improved by incorporating a higher pressure compressor, thus reducing the required storage volume. The higher pressure compressor would result in a decrease in PASS reliability and would require more input power to the compressor during recharge.

Although the probability of ballistic impact is higher with PASS, the probability of secondary damage to the other aircraft systems resulting from ballistic impact is less. In most cases, damage to PASS components results in leakage of the stored air or leakage of engine bleed air. Damage to the batteries would result in leakage of the caustic electrolyte. In addition, unlike PASS, the batteries are integrated in another aircraft system (dc power supply), and damage that would result in short circuits may impact the operation of other electrical equipment.

TABLE 30. AREA EXPOSED TO BALLISTIC
IMPACT COMPARISON.

| | Single engine (sq in.) | Twin engine (sq in.) |
|-------------------------------|------------------------------|----------------------------|
| <u>ELECTRIC START</u> | | |
| Batteries | 261 | 87 |
| Starter | 68 | 120 |
| Battery Charger | 50 | 50 |
| Wiring and Relays | <u>179</u> | <u>235</u> |
| TOTAL | 558 | 492 |
| <u>PASS</u> | | |
| Pressure Vessels and Controls | 868 | 502 |
| Starter | 48 | 96 |
| Compressor | 80 | 80 |
| Pneumatic Ducting | 140 | 212 |
| Battery | 59 | 59 |
| Battery Charger | 50 | 50 |
| Wiring | <u>40</u> | <u>40</u> |
| TOTAL | 1285 | 1039 |

Based on component dimensions that yield
maximum exposed area in any plane.

CONCLUSIONS

The results of the evaluation of the Pressurized Air Start System as compared to an electric start system for either a single- or twin-engine installation are summarized below:

| <u>Advantages of PASS</u> | <u>Disadvantages of PASS</u> |
|---|---|
| <ul style="list-style-type: none">● Improved starting performance● Main engine life improved● Weight reduction● Improved reliability● Lower maintenance● Life-cycle cost significantly improved● More backup start options● No winterization requirement for -65°F start | <ul style="list-style-type: none">● More aircraft installation volume required● Probability of gunfire impact higher● More components in system● Some development risk● Not in current inventory-personnel training |

In the past, small attack, utility, and aerial surveillance helicopters were designed with self-contained electrical starting systems based on the use of the Ni-Cd battery as an on-board power source. This system was usually selected over other candidate systems due to the acquisition cost constraints imposed on the designer. As illustrated by the life-cycle cost investigation conducted in this study, selecting a system based on the acquisition cost is very misleading when operating costs are high. This is the case with electrical start systems.

In the future, advanced helicopter engines will use main propulsion engines with higher cycle pressure ratios and turbine inlet temperatures in order to reduce engine size and weight, and fuel required for a given mission. These parameters usually result in the engines being more difficult to start and starter assist required to a higher speed. The Pressurized Air Start System has the characteristic of minimizing the starting system penalty to the aircraft for these engines.

Since the Pressurized Air Start System is a new concept for starting engines, specification requirements have not yet been established to guide the government or an airframe company in procurement of a system. The design study of the system components conducted in this program will form a basis for establishing these requirements.

With the exception of the recharge compressor, sufficient experimental development has been conducted with all of the PASS components to permit development of the system for flight evaluation.

RECOMMENDATIONS

In order to realize the advantages of the PASS for future helicopter designs, it is recommended that the following activities be initiated:

Specification

A specification should be prepared that defines the design and quality assurance requirements for the system. The proposed specification should integrate the applicable portions of existing military specifications and be similar to MIL-P-5518 (Design, Installation and Data Requirements for Aircraft Pneumatic Systems). It should provide the airframe design requirements for an evaluation of the system.

Component Development

To reduce the risk of engineering development for a production application, additional advanced development should be conducted to supplement the Research and Development Program of AiResearch. The Hi-Lo air turbine starter development is considered to be low risk and ready for production design. The pressure vessel and control manifold is also considered to be low risk. It is recommended that additional recharge compressor design and testing be conducted in order to verify the predicted life of the unit.

Flight Evaluation

After completion of additional compressor testing, it is recommended that a prototype system be installed on a helicopter and tested to verify the operational and structural integrity of the system when subjected to environmental and flight conditions.

APPENDIX A

SUMMARY OF AIRESEARCH COMPANY-SPONSORED PASS RESEARCH AND DEVELOPMENT PROGRAM

INTRODUCTION

AiResearch initiated a company-sponsored research and development program in 1974 in an effort to establish an improved starting system for small gas turbine engines. The program was initially started for auxiliary power units (APU's) for military aircraft and helicopters. As a result of interest received at government and industry briefings on the program progress, the program was expanded to include main propulsion engines.

SUMMARY

A summary of the tasks that have been conducted is presented below:

PASS for APU's

- Conceptual Design - A trade-off study of various start motor and compressor configurations was conducted during this phase.
- Preliminary System Design - A preliminary design of the components selected from the trade-off study was made.

- Component Design - Detailed component designs of the start motor, compressor, pressure vessel/manifold assembly, and miscellaneous valves were made.
- Start Motor Testing - Start motor tests to establish performance characteristics and mechanical design were conducted.
- Prototype System Testing - A prototype system using industrial-type pressure vessels, valves, and a compressor with the aircraft-type start motor was fabricated.
- APU Demonstrator Testing - The prototype system was installed in an APU test cell and used to start the AiResearch Model JSF190 (used on the F-15 aircraft) and the AiResearch Model GTCP36-50 (used on the A-10 aircraft).
- Pneumatic Amplifier Testing - A breadboard pneumatically driven pressure amplifier was fabricated and tested to determine the feasibility of recharging the system with a low-cost compressor design.

PASS for Main Propulsion Engines

- Conceptual Design - A trade-off study of various start motor and compressor configurations and system component arrangements was conducted.
- Component Design - Detailed designs of system components were made to estimate manufacturing cost, weight, and performance.
- Breadboard Compressor Testing - A breadboard compressor was fabricated by AiResearch and installed on a vari-drive to demonstrate the feasibility of compressing air to 1000 psig with a two-stage unit.
- Prototype Compressor Development - A prototype two-stage compressor is currently under development for integration testing with an air turbine drive motor.
- Air Turbine Starter Testing - The AiResearch Model ATSl8-3 Air Turbine Starter (used on UTTAS and AAH) was modified and tested to determine performance characteristics using partial admission nozzles.

The PASS arrangements selected for APU's and main engine propulsion engines as a result of this program are essentially the same except for the starter design. The

APU uses an expanding vane motor that drives the APU starter pad without the use of intermediate reduction gearing. The unit requires relatively high pressure (150 to 250 psig) for efficient operation. The main propulsion engine PASS uses a partial-admission high-pressure/low-pressure air turbine starter. This allows using high pressure from the air bottle as the normal start procedure and low pressure from a pneumatic ground cart or engine cross-bleed as a backup.

The expanding vane motor could be used to start main propulsion engines in a single-engine installation if starting from a low-pressure pneumatic ground cart were not required. The vane motor has the advantages of reduced pressure vessel size and lower cost compared to the air turbine starter.

PASS FOR AUXILIARY POWER UNITS

The PASS concept for APU's was designed in an effort to establish a lighter weight system with improved performance at low temperature over current hydraulic accumulator and electric start systems. AiResearch has designed several hydraulic and electric starting systems for recent APU applications, and in most cases, the starting system weight was in excess of the basic APU weight. In addition, low temperature (-25°F and below) starting problems frequently are encountered due to the very high viscosities of hydraulic fluid and poor battery performance at low electrolyte temperatures.

The PASS program that AiResearch has been conducting as a company-sponsored activity has included design studies, prototype hardware development, and demonstration testing on AiResearch APUs. Sufficient testing has been conducted to date to indicate a high confidence level that advanced development can be accomplished with minimum risk.

Most recent military aircraft and helicopters with APU's use hydraulic starting for the APU. PASS offers several advantages over hydraulic starting. Some of these include:

- Low-Temperature Operation - The very high viscosity of hydraulic fluids at low temperature significantly degrades the performance capability of the hydraulic system. With pneumatics (PASS), only a slight degradation is encountered due to the lower air temperature of the working fluid.
- Weight Reduction - PASS offers a weight savings over hydraulic starting. This is directly related to the low temperature problems of the hydraulic system. The lower the required temperature, the higher the payoff with the PASS. Also, multiple start attempts can be incorporated in the PASS system for less weight than hydraulic accumulator systems.

- Low Cost - PASS has been designed to use as many existing low-cost components as possible. Those components that are new were initially designed under a design-to-cost program to be competitive with hydraulic systems.
- No Fire Hazard - With PASS, the working fluid is air which will not burn in the event of bottle damage or leakage on a high-temperature component.
- System Reliability - PASS is a self-contained system that functions only to start the APU. With a hydraulic start system that is recharged from the aircraft's utility hydraulic start system can impact the operation of an in-flight system (utility hydraulic).
- Installation Complexity - The system requires only one line from the pressure vessel to the start motor. This line can be a flexible hose, simplifying the tubing bends required for the dual line hydraulic start system.

APU START MOTOR

The trade-offs conducted in evaluating a start motor for the APU PASS is shown in Table A-1. As illustrated, the motor selected is a rotary-vane motor with internal expansion.

TABLE A-1. PASS START MOTOR EVALUATION FOR APU'S.

| Configurations studied | Major considerations | Configuration selected | Characteristics |
|---|--|------------------------|---|
| <ul style="list-style-type: none"> • Radial and Axial Turbines | <p>Reduction Gearbox Required</p> <p>Relatively High Cost</p> | Expanding Vane Motor | <p>High Efficiency - Minimum Storage Volume</p> <p>Small Package Size - Lightweight</p> <p>Simple Design - Direct Drive</p> <p>Low Cost</p> |
| <ul style="list-style-type: none"> • Positive Displacement Motors <ul style="list-style-type: none"> • Gear • Lysholm • Lobe • Vane | <p>Complex Designs for Internal Expansions</p> <p>Simple Design - Direct Drive</p> | | |

The motor consists basically of a rotor with sliding vanes mounted eccentric to the housing center line. Pressurized air is introduced at the inlet port and expands as the rotor turns. The exhaust is discharged radially through a series of slots in the motor housing. The motor mounts directly on the APU starter pad and requires no additional gear reduction for proper speeds and torques.

Operation of the air vane starter is illustrated in Figure A-1. As shown, volume (V_a) is charged to the supply pressure (200 psi). As the rotor rotates, this volume increases to V_b due to the eccentricity between the rotor and housing. As the volume increases, the pressure decreases as illustrated on the graph in Figure A-1. The expansion ratio (V_b/V_a) of the motor is 2.35.

The air vane starter configuration with which AiResearch has been conducting development testing is shown in Figure A-2. An exploded view of the motor is shown in Figure A-3 and the size of the rotor and vanes is illustrated in Figure A-4.

The development test air vane starter has an operating speed range of zero to 12,000 rpm. The unit develops approximately 10 peak shaft horsepower. Peak adiabatic efficiency of the unit is approximately 0.50.

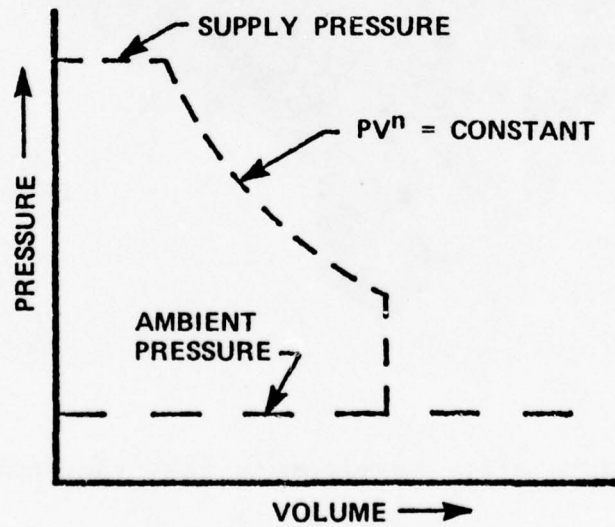
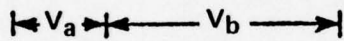
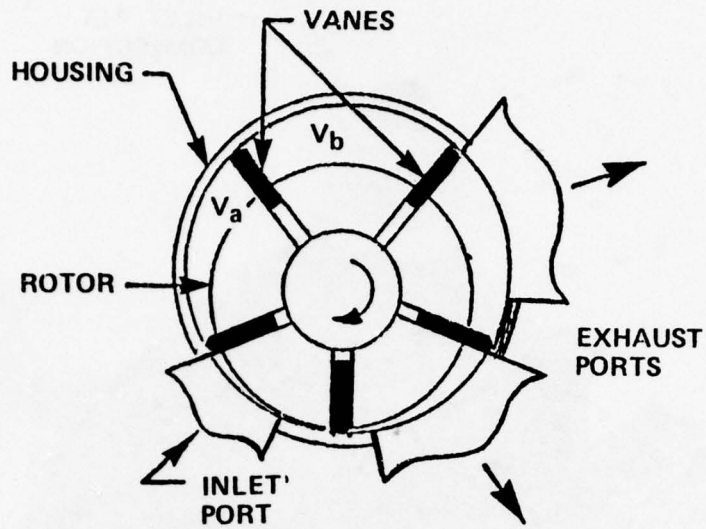

Figure A-1. Air vane starter operation.

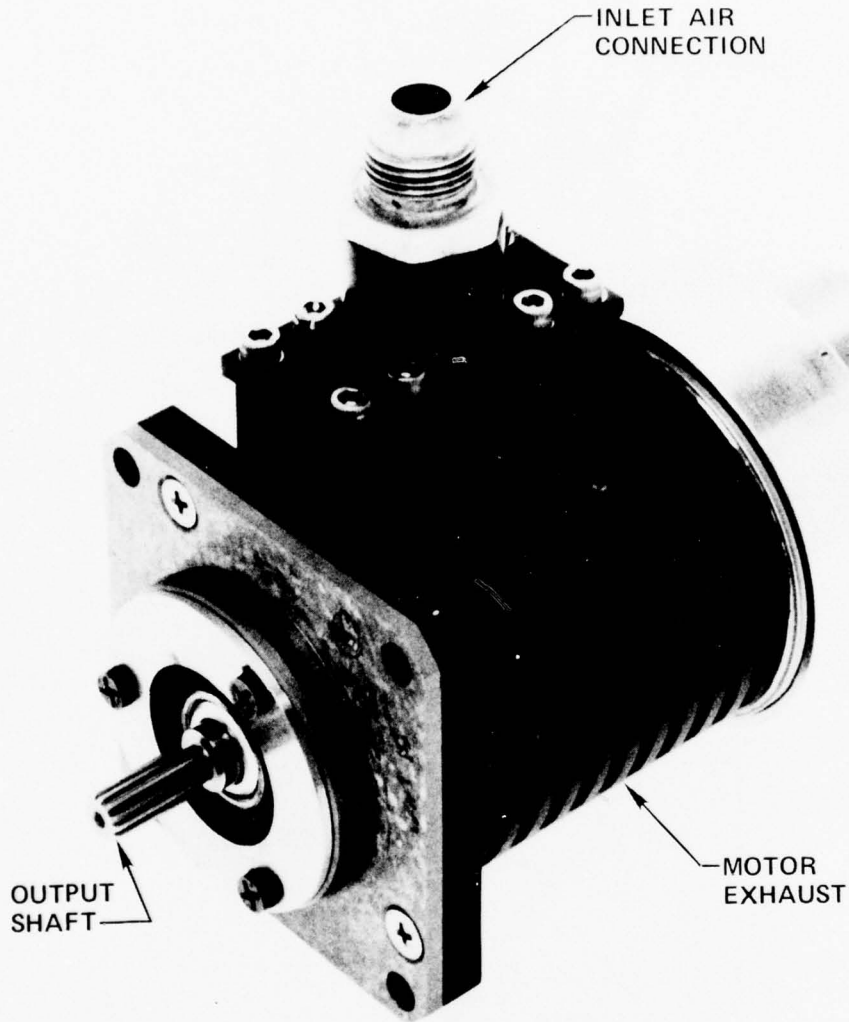

Figure A-2. Development test vane motor.

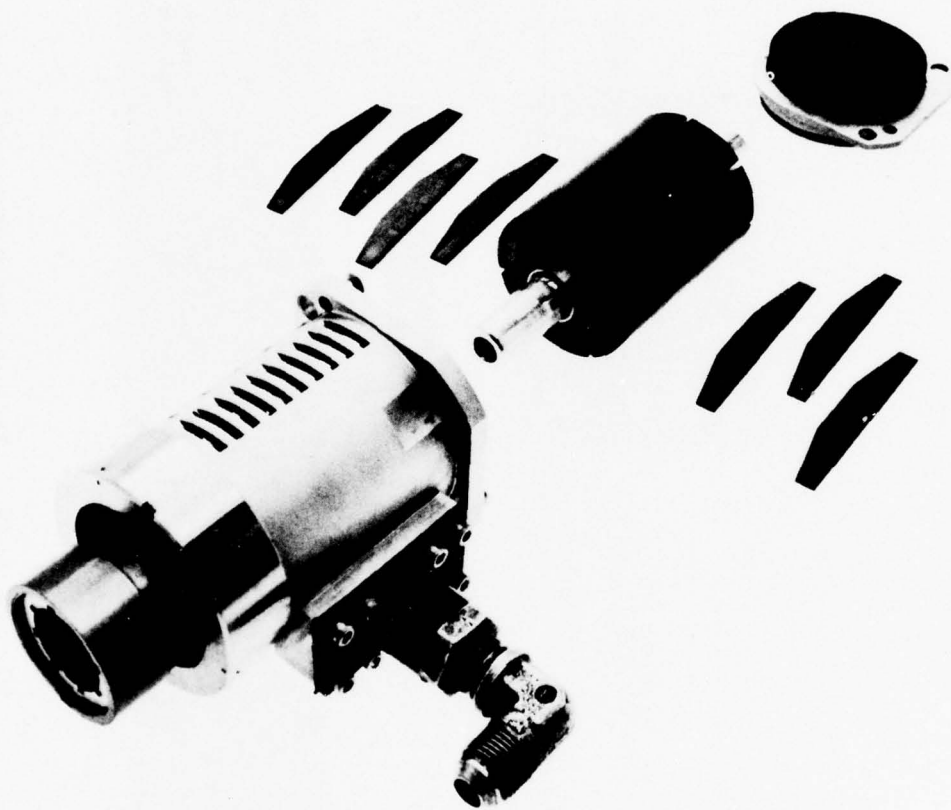

Figure A-3. Exploded view of air vane starter.

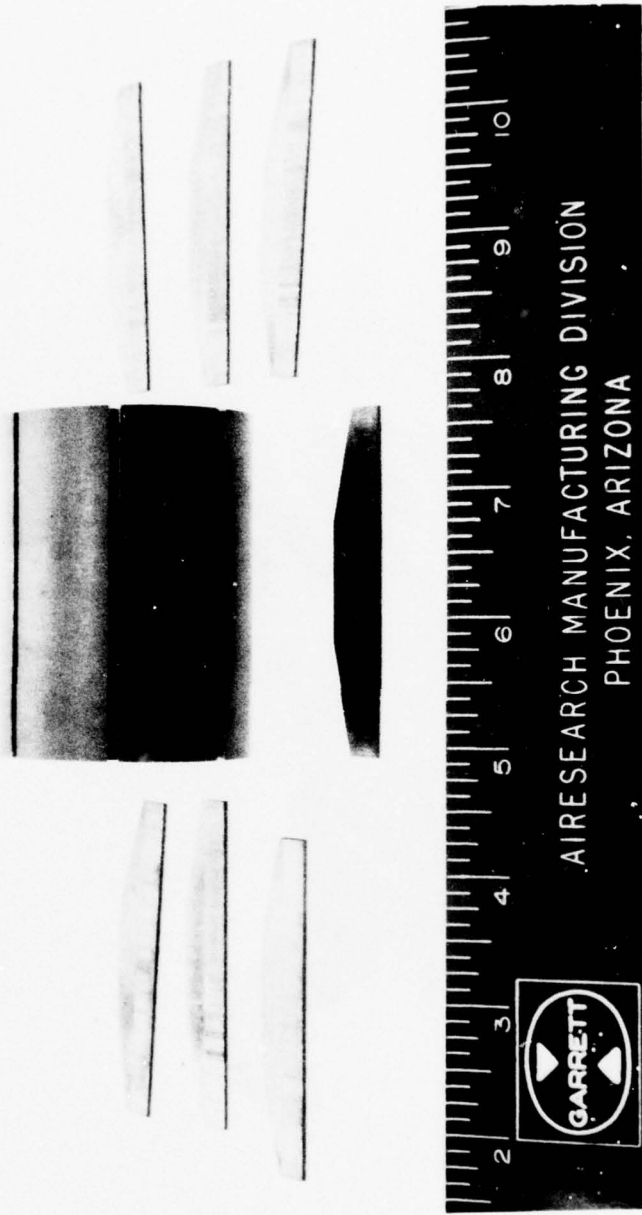

Figure A-4. Air vane starter rotor and vanes.

PASS has been in the design and development phases for approximately three years. During this period, several air vane starter configurations have been tested. This testing has included:

- Performance Testing
- Vane Material Evaluation
- Housing Material Evaluation
- Rotor Configuration Including Vane Springs and Self-Pressurized Vanes
- Endurance Testing on a Flywheel Rig
- Low Temperature Testing (-40°F)

PNEUMATIC AMPLIFIER

The initial compressor design for the APU PASS was a low-cost pneumatic amplifier. The pneumatic amplifier operates with APU or engine bleed air to boost the pressure level of the bleed air for storage in a pressure vessel. The unit is shown schematically in Figure A-5. As shown, the unit is a single-stage, free-piston pump that drives and compresses in each direction. Bleed air is used to drive the motor piston as well as to charge the compressor cylinder. By charging the compressor with bleed air, the overall compression ratio of the unit is less since the supply air is initially 3 to 4 atmospheres.

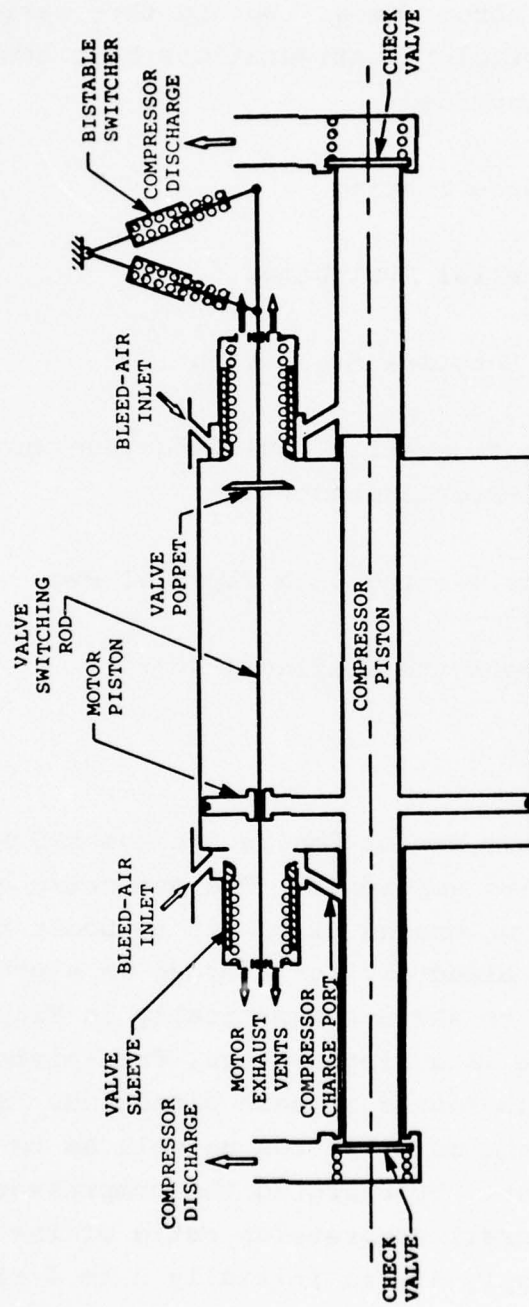

Figure A-5. Schematic arrangement of pneumatic amplifier.

The dimensions and characteristics of the breadboard unit designed are shown in Figure A-6. Testing of this unit included functional operation and performance evaluation. The results of these tests indicated that the volumetric efficiency was low due to the high compression ratio required in only one stage.

The APU PASS compressor was later selected as a motor-driven, two-stage unit as determined in the evaluation of PASS for main propulsion engines.

PROTOTYPE SYSTEM TESTING

Prototype system testing was conducted using a fly-wheel test rig. The test setup is illustrated in Figure A-7. Laboratory air bottles, control valves, and pressure amplifier were used to simulate the prototype system during these tests.

APU DEMONSTRATOR TESTS

The air vane starter and prototype system were installed on the AiResearch Model GTCP36-50 APU (used on A-10 aircraft) and the Model JFS190 (used on F-15 aircraft) for demonstration testing. Photographs of the test setup installed in the AiResearch laboratory during these tests are shown in Figures A-8 through A-12.

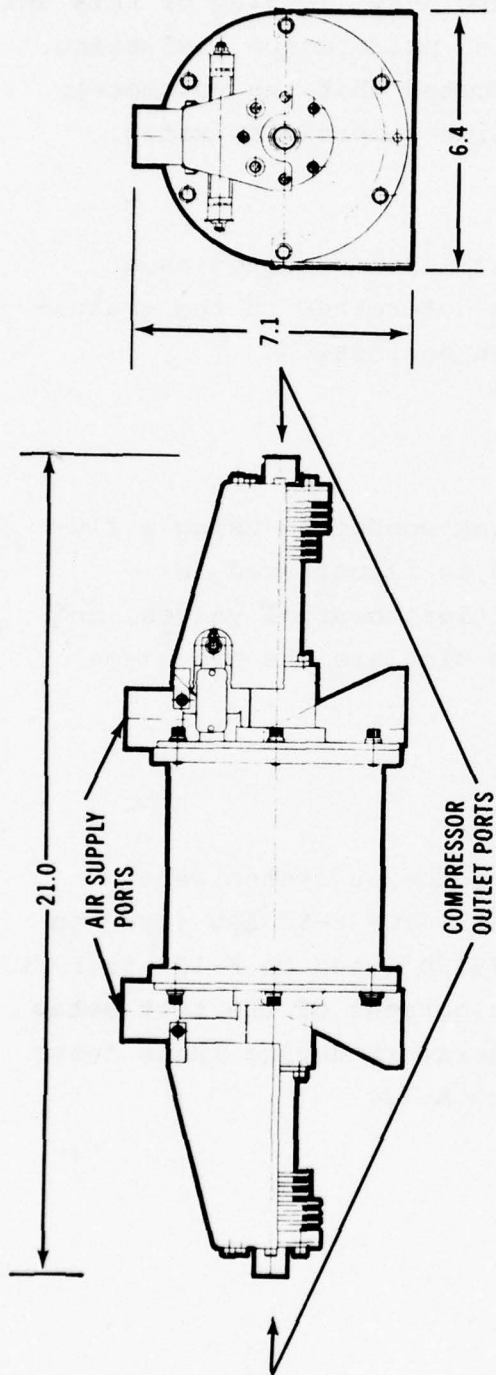

AMPLIFIER DATA

- SUPPLY PRESSURE—30 TO 100 PSIG
- OUTLET PRESSURE—1000 PSIG
- SUPPLY AIRFLOW—5.5 TO 8.5 LB./MIN.
- OUTLET AIRFLOW—0.15 TO 0.30 LB./MIN.
- SIZED TO RECHARGE 300 IN³ AIR BOTTLE IN 3 TO 5 MIN.
- WEIGHT—12.15 LB.

Figure A-6. Pneumatic amplifier, pneumatically driven.

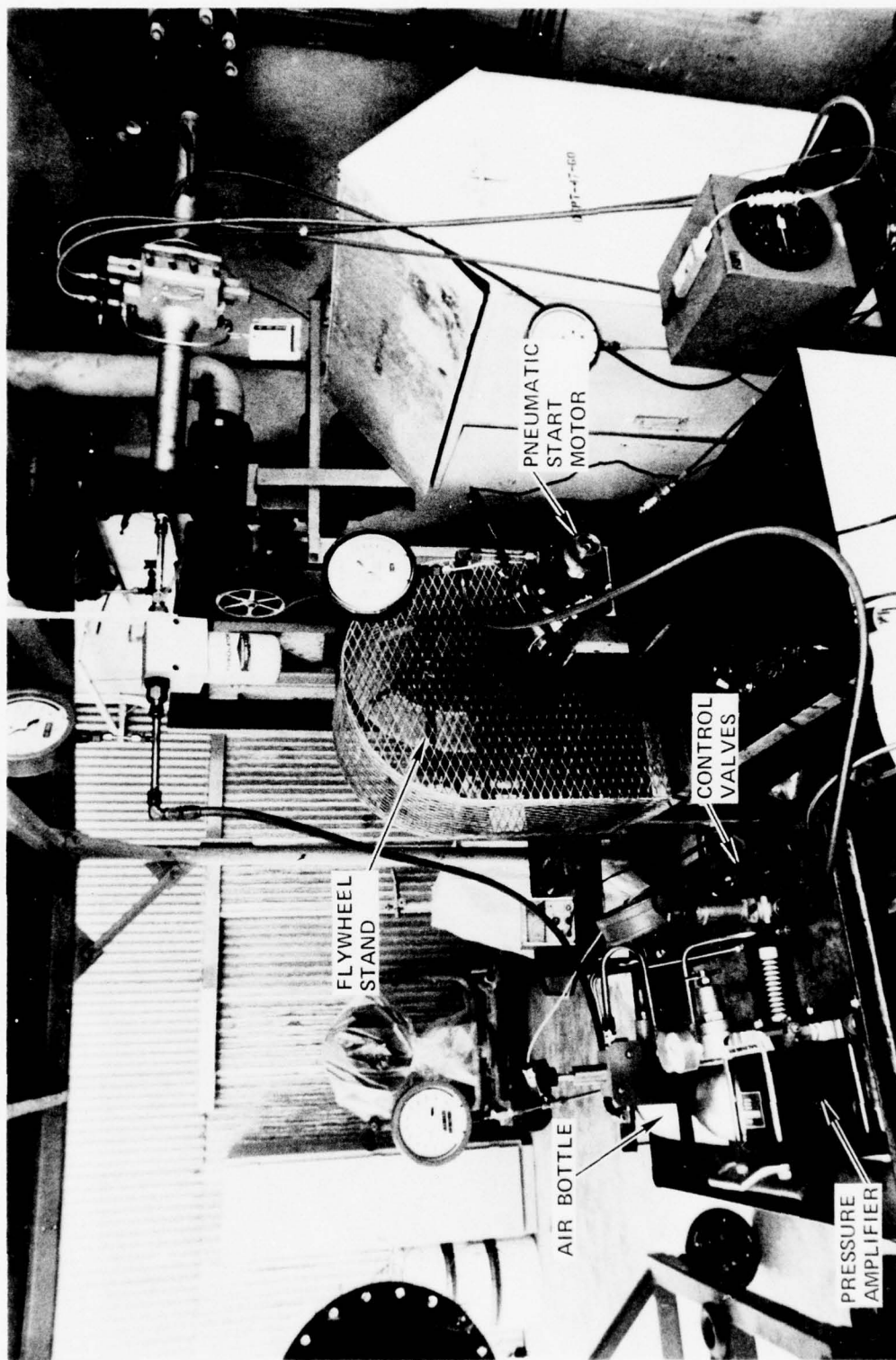

Figure A-7. Flywheel test rig for air vane starter testing.

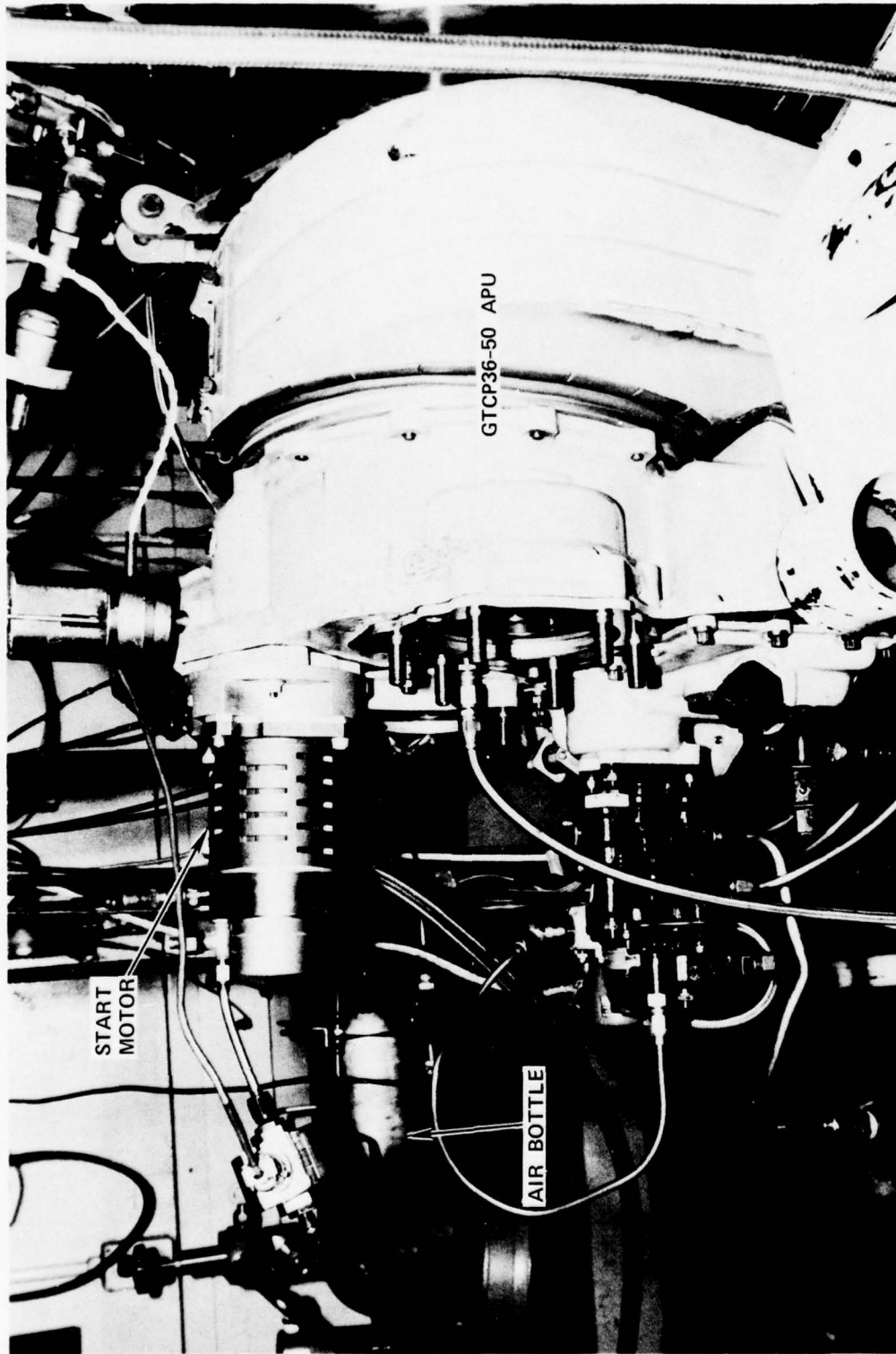

Figure A-8. Model GTCP36-50 APU demonstrator test setup, pressurized air start system.

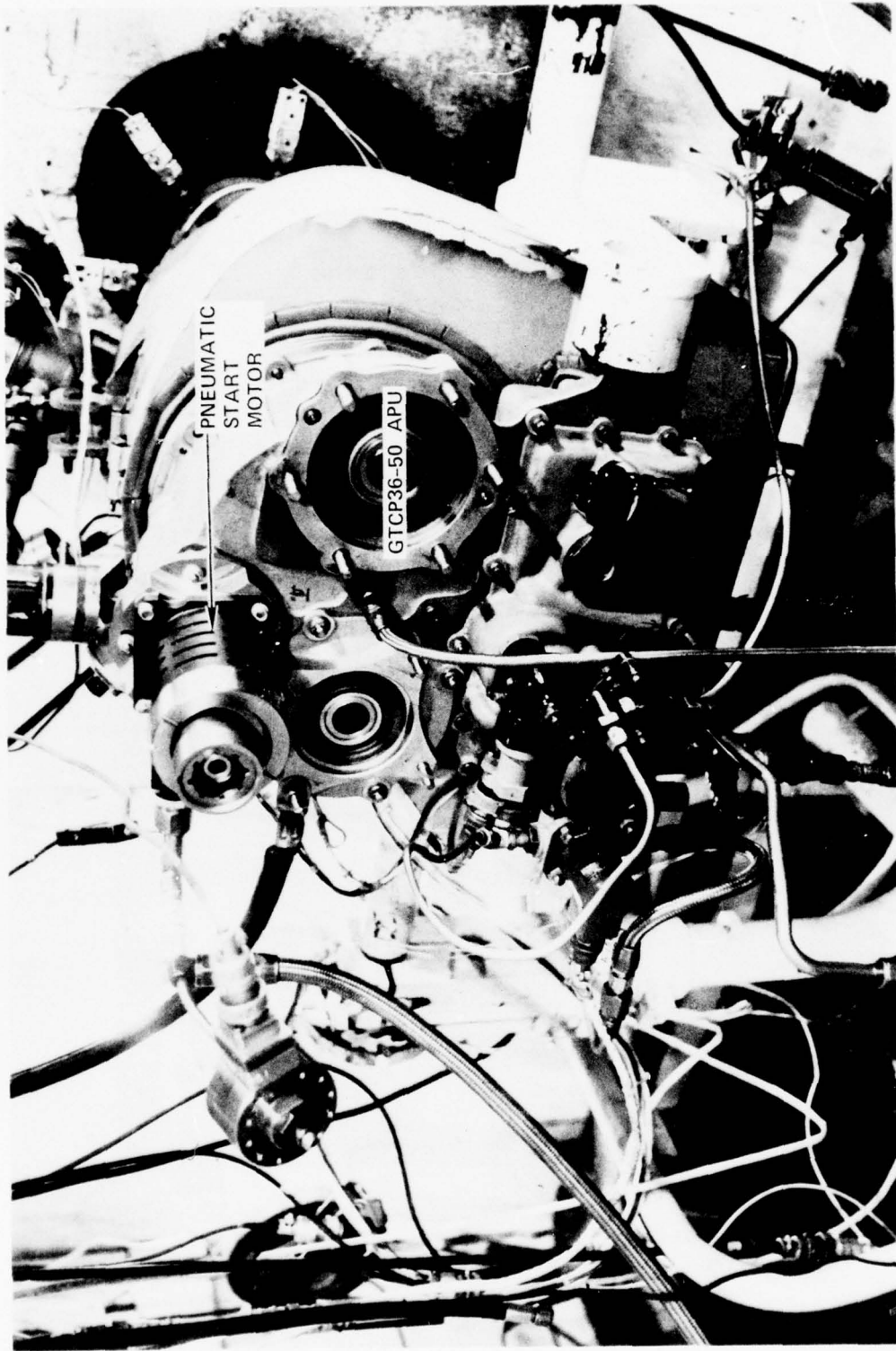

Figure A-9. Air vane starter installed on Model GTCP36-50 APU.

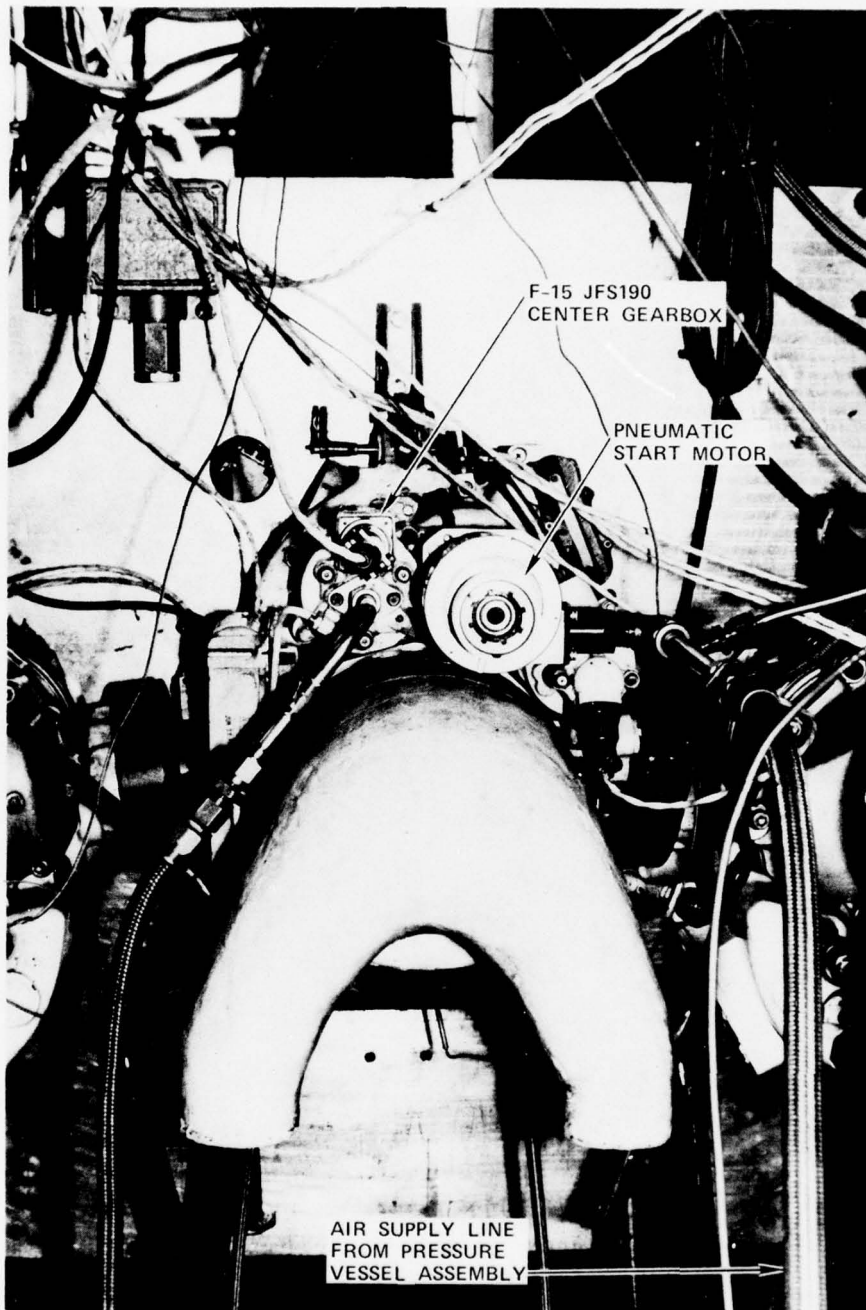

Figure A-10. Model JFS190 APU demonstrator test setup, pressurized air start system.

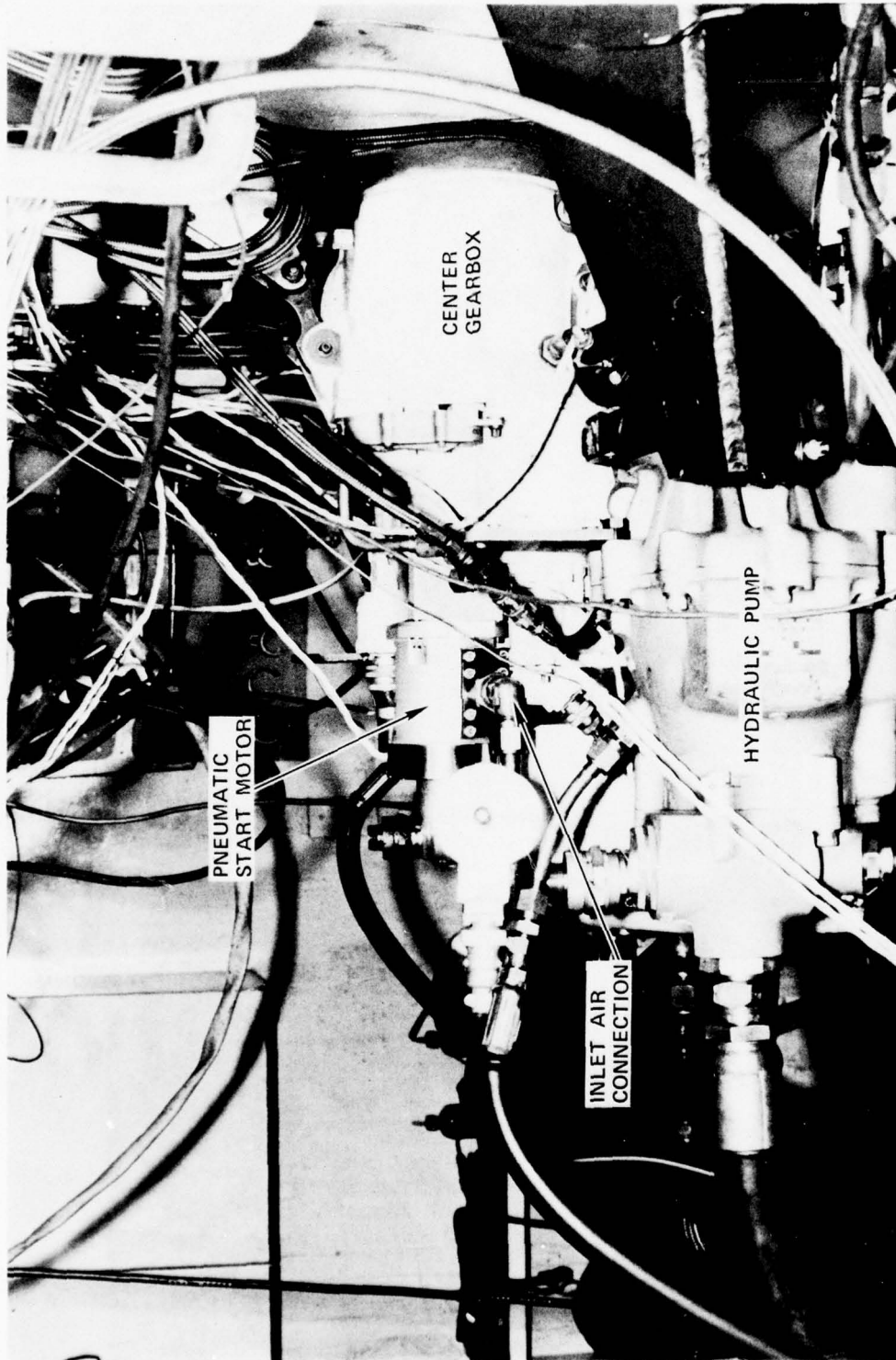

Figure A-11. Model JFS190 APU demonstrator test setup, pressurized air start system.

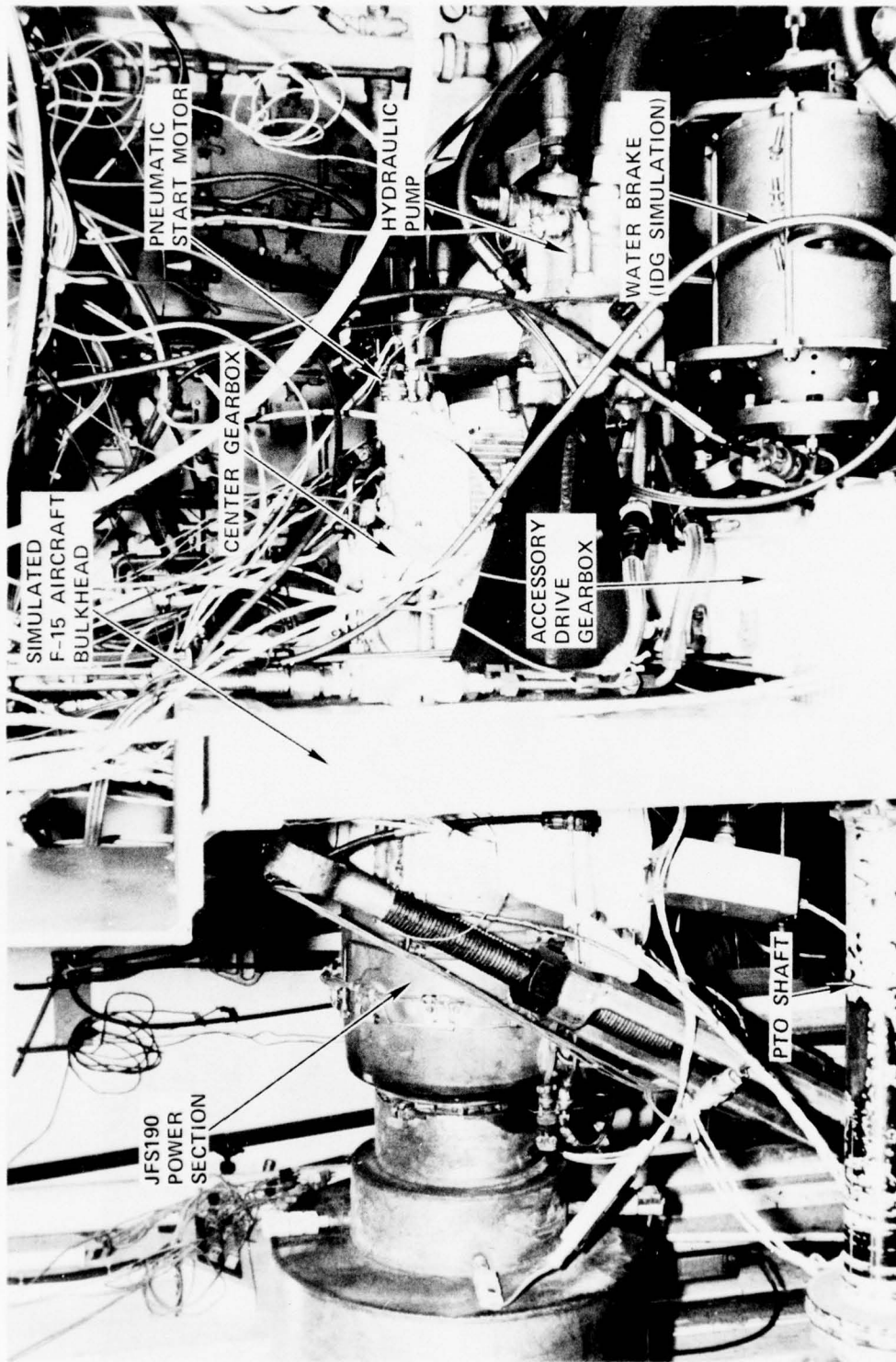

Figure A-12. Model JFS190 APU demonstrator test setup, pressurized air start system.

PASS FOR MAIN PROPULSION ENGINES

A design and development program of PASS for main propulsion engines was initiated in October 1975. Based on the results of surveys of engine manufacturers, air-frame companies, and government agencies, it was determined that PASS would be competitive with electric start systems currently used on general aviation and utility aircraft as well as helicopters.

Preliminary evaluation of the system, compared to electric starting, indicated that PASS:

- Is acquisition cost competitive
- Offers improved reliability
- Offers improved maintenance costs
- Reduces weight
- Provides lower temperature starting capability

A discussion of the activities conducted to date under this program is presented in the following paragraphs.

ENGINE STARTER COMPARISON

Based on the results of APU PASS starter studies, an evaluation was made comparing the air vane starter with the dual-mode high/low-pressure air turbine starter. The candidate starter configurations are illustrated in Figure A-13. A comparison of their characteristics is shown in Table A-2. Detail drawings of each unit were made in order to evaluate cost and complexity.

The significant disadvantage of the air vane starter for propulsion engines is the requirement for high-pressure air for starting. A low-pressure pneumatic ground cart cannot be used as a backup to the on-board system. In addition, in twin-engine installations, cross bleed cannot be used to start the second engine after one has been started.

AIR TURBINE STARTER TESTING

In order to determine the performance characteristics of an air turbine starter with partial admission that would be capable of starting engines up to approximately 5000 shp, the AiResearch Model ATSl8-3 Air Turbine Starter used on the UTTAS and AAH helicopters was modified to the partial admission configuration. This unit has a single-stage axial turbine, 3.2 inches in diameter. The gear ratio between the turbine and output shaft is 6.6:1. A photograph of the turbine and reduction gearing is shown in Figure A-14.

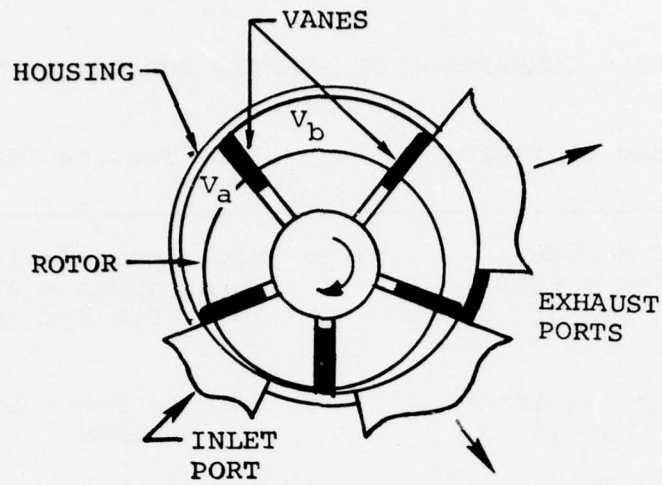

AIR VANE STARTER

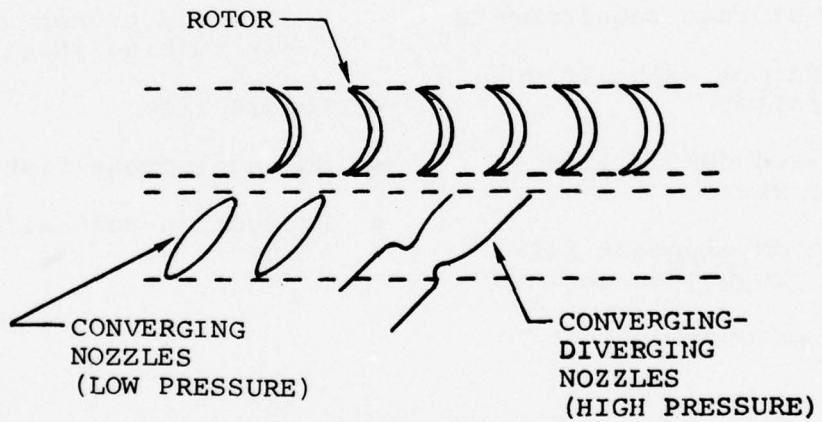

AIR TURBINE STARTER

Figure A-13. Candidate starter configuration.

TABLE A-2. COMPARISON OF STARTER CHARACTERISTICS.

| Air Vane Starter | Air Turbine Starter |
|---|---|
| <ul style="list-style-type: none"> ● Low-speed design Rotor speed = 6000 to 12,000 rpm at cutout | <ul style="list-style-type: none"> ● High-speed design Rotor speed = 50,000 to 70,000 rpm at cutout |
| <ul style="list-style-type: none"> ● No gearbox required for most engines | <ul style="list-style-type: none"> ● Gearbox required for all engines |
| <ul style="list-style-type: none"> ● Inherently speed-limited - requires no containment | <ul style="list-style-type: none"> ● Containment required |
| <ul style="list-style-type: none"> ● Operates with high pressure supply - single inlet | <ul style="list-style-type: none"> ● Operates with high or low pressure supply - dual admission nozzles |
| <ul style="list-style-type: none"> ● Air storage requirements - Minimum with air vane starter | <ul style="list-style-type: none"> ● Air storage requirements - Slightly higher with air turbine starter |
| <ul style="list-style-type: none"> ● Limited design life - vane wear | <ul style="list-style-type: none"> ● Longer life |
| <ul style="list-style-type: none"> ● Some development risk for propulsion engines | <ul style="list-style-type: none"> ● No development risk |
| <ul style="list-style-type: none"> ● Low production cost | <ul style="list-style-type: none"> ● Production cost slightly higher |

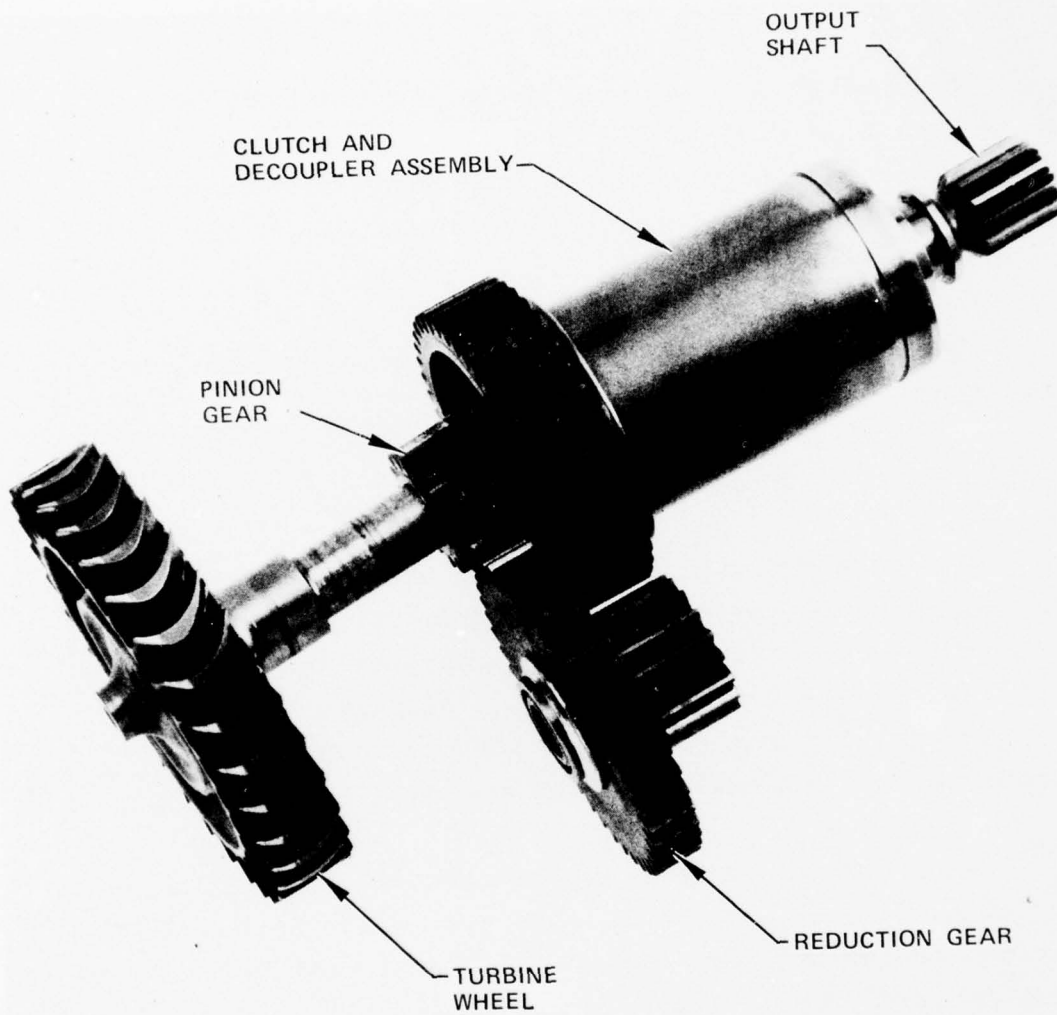

Figure A-14. Turbine and reduction gearing of starter Model ATSl8-3.

High pressure converging-diverging nozzles were fabricated for the test. The starter was calibrated on a flywheel test stand at various supply pressures.

The performance of the starter in the low-pressure mode with a partial-admission nozzle was determined by blocking three stator vanes of the UTTAS starter nozzle. This is the space required for installation of the high-pressure nozzles.

The results of this testing are presented in Table A-3.

COMPRESSOR DESIGN STUDIES

A design evaluation of various compressor configurations, pressure level, and compressor drive options was studied. Table A-4 presents a summary of the compressor configuration and pressure level evaluation. Drawings were prepared for the selected 1000-psi configuration in order to estimate the fabrication cost.

Various compressor drive options were also studied as illustrated in Figure A-15. The accessory gearbox-driven units are the lightest weight and lowest cost compared to the motor-driven units; however, these units are not adaptable to various aircraft due to the special drive arrangement.

TABLE A-3. RESULTS OF PERFORMANCE TESTING
AIR TURBINE STARTER MODEL ATSl6-3
MODIFIED FOR PARTIAL-ADMISSION.

| Starter pressure ratio | Peak adiabatic efficiency | Starter effective nozzle area (in. ²) |
|------------------------------|---------------------------------|--|
| (High-Pressure Mode) | | |
| 10 | 0.603 | 0.112 |
| 12 | 0.621 | ↓ |
| 15 | 0.623 | |
| 17 | 0.638 | |
| (Low-Pressure Mode) | | |
| 2 | 0.476 | 0.510 |
| 3 | 0.553 | ↓ |
| 4 | 0.590 | |
| 5 | 0.595 | |

NOTES:

1. Starter pressure ratio is inlet total pressure/
exhaust static pressure.
2. Adiabatic efficiency is output shaft horsepower/
inlet air horsepower.

TABLE A-4. PASS COMPRESSOR EVALUATION.

| Configurations studied | Major considerations | Configuration selected | Characteristics |
|--|---|---------------------------|---|
| <ul style="list-style-type: none"> • High Pressure (3000 psi) | <ul style="list-style-type: none"> • Past Experience - Low Reliability • Complex Controls • Low Efficiency | | <ul style="list-style-type: none"> • Current Technology Design |
| <ul style="list-style-type: none"> • Moderate Pressure (1000 to 2000 psi) | <ul style="list-style-type: none"> • Cost Effective • High Efficiency | <p>→ 1000 psi</p> | <ul style="list-style-type: none"> • Low Drive Speed • Low Bleed Flow Consumption |
| <ul style="list-style-type: none"> • Centrifugal | <ul style="list-style-type: none"> • High Speed - Low Efficiency | <p>↘ Two-Stage Piston</p> | <ul style="list-style-type: none"> • Growth Capability (Higher Pressure - Increased Flow) |
| <ul style="list-style-type: none"> • Piston-Type | <ul style="list-style-type: none"> • Low Drive Speed • Low Cost | | |

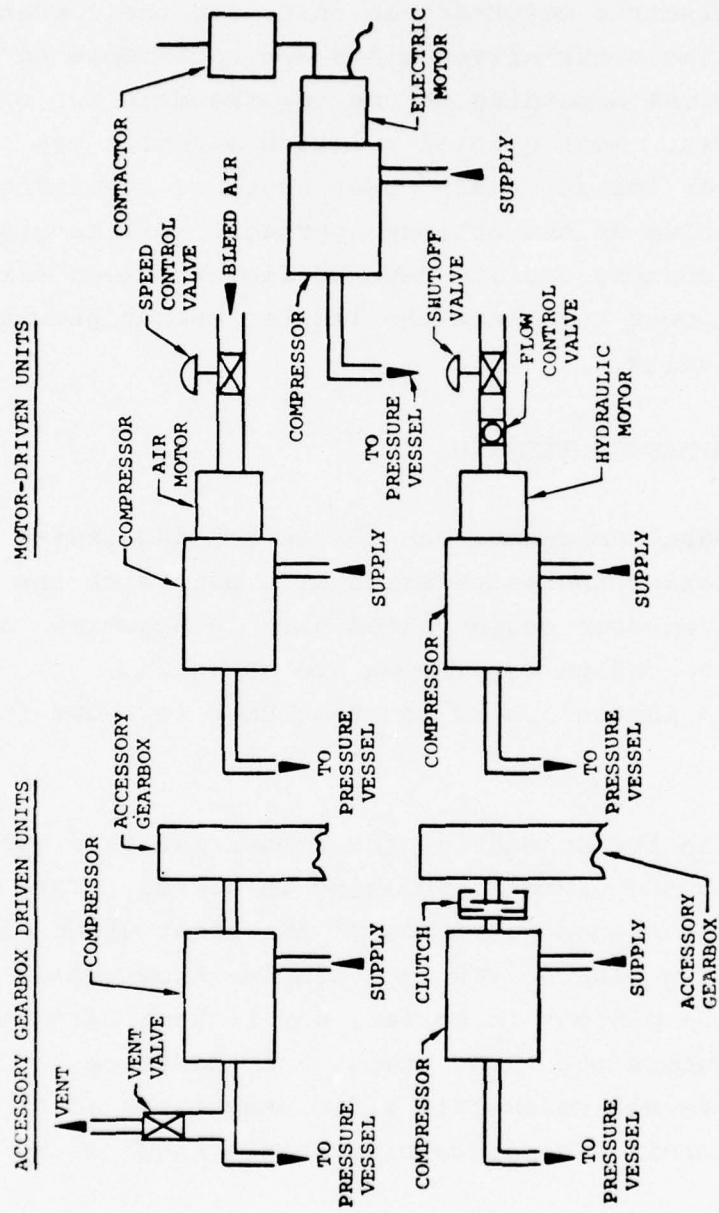

FIGURE A-15. Compressor drive options.

The air motor and hydraulic motor driven units are the lowest weight compared to the electric motor drive. However, the electric motor-driven units are the lowest cost. All of the motor-driven units are applicable to PASS installations depending on the requirements for other aircraft systems. Most general aviation aircraft use electrical power for secondary power systems, resulting in the electric drive as the optimum approach. Military aircraft and helicopters usually have sufficient bleed air and hydraulic power to select the lighter weight pneumatic and hydraulic units.

BREADBOARD COMPRESSOR TESTING

A breadboard compressor was fabricated and tested to determine operating characteristics of a unit with the inlet pressurized from engine bleed air. A schematic of the unit and the design conditions are shown in Figure A-16. A photograph of the test unit is shown in Figure A-17.

As shown on the schematic, the compressor is a two-stage unit with the pistons operating in series. That is, the second-stage piston is on top of the first stage with the reciprocating mass driven by a single-throw crankshaft. With the pistons in series, any leakage past the second stage enters the first stage, and therefore, improves the overall volumetric efficiency compared to an arrangement wherein a separate piston is vented to the crankcase.

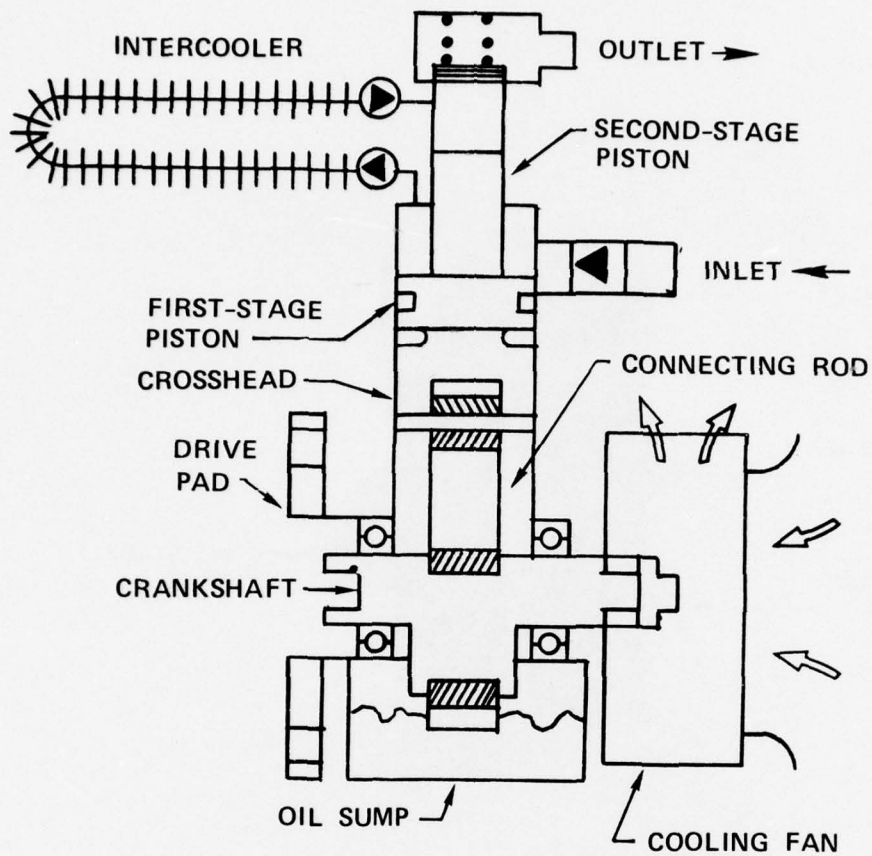

- PERFORMANCE RATING

AIRFLOW = 0.5 LB/MIN
 AT 24 PSIG AND 250F
 SUPPLY CONDITIONS

- OPERATING SPEED

4000 RPM (NOMINAL)

- REQUIRED INPUT POWER

3.25 HP AT 1000 PSIG
 OUTLET PRESSURE

Figure A-16. Schematic of PASS compressor.

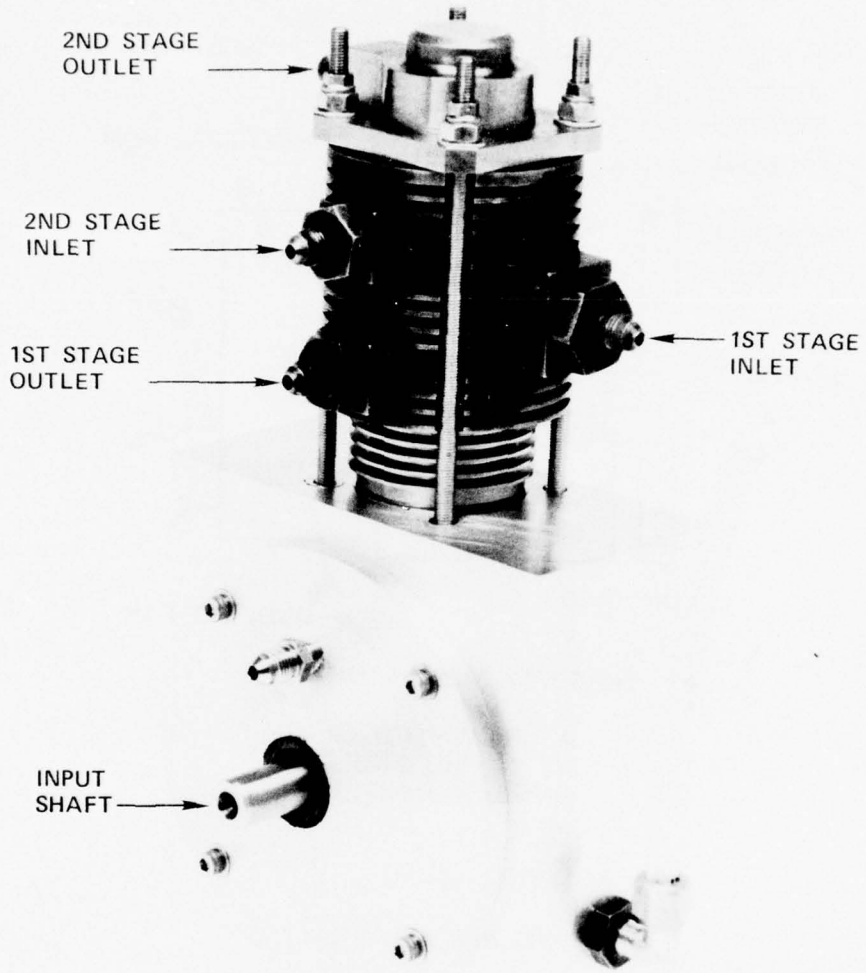

Figure A-17. Breadboard PASS compressor.

INTEGRATED COMPRESSOR/TURBINE DRIVE DEVELOPMENT

A development program for a two-stage compressor with an integrated air-turbine drive unit was recently initiated. AiResearch is working with the MC Division of Kelsey-Hayes on this design. The compressor portion of the unit will be fabricated by MC, and AiResearch will integrate the unit with the turbine and reduction gearing. The compressor will be delivered to AiResearch for testing in November 1977.

PRESSURE VESSEL AND CONTROLS DESIGN

The main propulsion engine PASS study phase includes a comparison of various pressure vessel designs, an analysis of control component requirements, and a design of a pressure regulator and shutoff valve. Proposals were solicited from component manufacturers (pressure vessel, burst disc, pressure gauges, pressure switches, check valves, etc.) to establish the characteristics and cost of these components.

A comparison was made of aluminum, steel, and glass filament-wound (composite) pressure vessels. Although the manufacturing cost of the metallic units is lower, the composite pressure vessel weight is significantly lower. This is illustrated graphically in Figure A-18. An additional advantage of the composite units is their resistance to shattering when subjected to gunfire. The metallic units can be designed to meet gunfire requirements; however, this results in a significant weight penalty.

Detail design and analysis were conducted for the PASS pressure regulator and shutoff valve. This component was selected for detail design in order to determine the configuration required to minimize leakage in the closed posi-

P = BURST PRESSURE, PSI
V = INTERNAL VOLUME, CU IN.
W = WEIGHT, LB

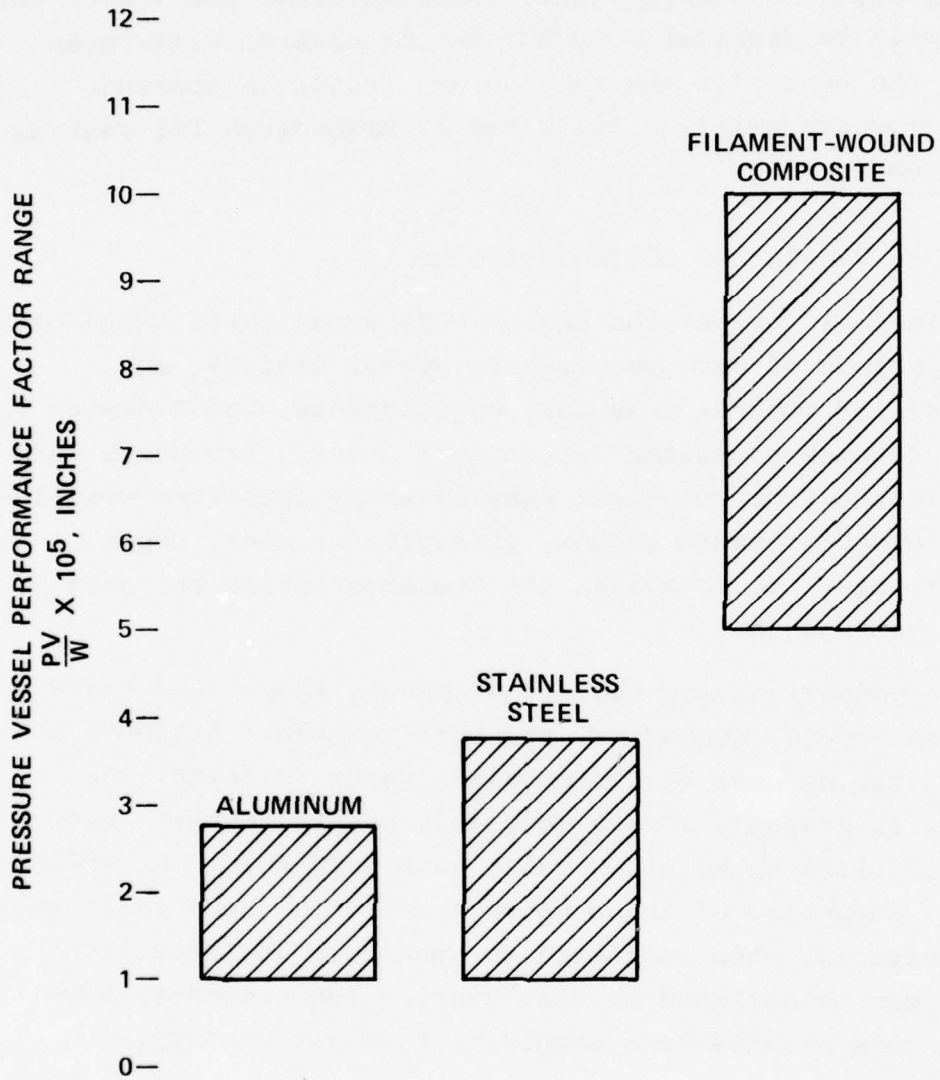

Figure A-18. Weight comparison of cylindrical pressure vessels.

tion and provide a controlled opening rate during start-up to prevent high starter inlet pressures resulting in an impact torque to the engine. The selected design is shown and described on the schematic diagram of Figure A-19.

Although this component has not been fabricated and tested to date, a similar unit, based on this design, has been tested in a 3000-psi system for regulating air pressure to an air motor used in a gun-drive system.

PRESSURE VESSEL BLOWDOWN CHARACTERISTICS

Testing was conducted to determine the blowdown characteristics of various pressure vessels. The conventional approach to modeling a stored-gas system is to assume that the gas expands isentropically (no heat transfer). In a starting system, this procedure results in sizing the pressure vessel in excess of that actually required. This is due to the airflow requirements of the starter being dependent on the air supply temperature.

The results of the AiResearch testing for a configuration similar to PASS are shown in Figure A-20. As shown, the temperature at the starter inlet is much higher than that calculated assuming isentropic conditions.

The test setup used for this test is shown in Figure A-21. An orifice was used to simulate the starter turbine nozzle. Eight feet of tubing was used to simulate the aircraft ducting.

Data from this test program was used in preparing the AiResearch computer program simulating the PASS starting system.

DESCRIPTION:

THIS IS A NORMALLY CLOSED, POPPET-TYPE, PRESSURE REGULATOR AND SHUTOFF VALVE WITH SOLENOID CONTROL FOR THE SHUTOFF MODE.

SHUTOFF OPERATION:

WITH THE SOLENOID DE-ENERGIZED, AS SHOWN, CHAMBER "A" IS VENTED TO AMBIENT THROUGH THE SOLENOID. THE ACTUATOR SPRING, ASSISTED BY INLET PRESSURE TO THE METERING POPPET, DRIVES THE POPPET TO THE CLOSED POSITION.

PRESSURE REGULATION:

WITH THE SOLENOID ENERGIZED, THE SOLENOID BALL MOVES TO CLOSE OFF THE AMBIENT VENT AND PERMIT VALVE INLET PRESSURE TO ENTER CHAMBER "A". SINCE THE CHAMBER "A" PISTON HAS A GREATER AREA THAN THE METERING POPPET, THE DIFFERENTIAL FORCE OVERCOMES THE CLOSING SPRING LOAD TO OPEN THE POPPET. AS THE METERING POPPET OPENS, PRESSURE ENTERS CHAMBER "B" THROUGH THE CONTROL ORIFICE AND ACTS AGAINST REFERENCE PRESSURE REGULATOR POPPET AND TRIM PISTON. OUTLET PRESSURE ACTS ON BACK SIDE OF THE TRIM PISTON. WHEN THE OUTLET PRESSURE REACHES THE REGULATOR SET POINT, THE REFERENCE PRESSURE REGULATOR WILL CONTROL CHAMBER "B" (OPENING PRESSURE) TO A PREDETERMINED SCHEDULE. THE REFERENCE PRESSURE REGULATOR ACCOMPLISHES THIS FUNCTION BY BLEEDING OFF, TO AMBIENT, THE EXCESS INBLED FLOW THROUGH THE CONTROL ORIFICE. THIS PROCESS CONTINUES UNTIL A FORCE BALANCE ACROSS THE ACTUATOR POSITIONS THE METERING POPPET TO SATISFY THE REGULATION SET POINT REQUIREMENTS.

A MANUAL RECALIBRATION FEATURE IS PROVIDED SUCH THAT THE SPRING FORCE BALANCE IN THE REFERENCE PRESSURE REGULATOR IS CHANGED FOR INCREASING OR DECREASING REGULATOR SET POINT.

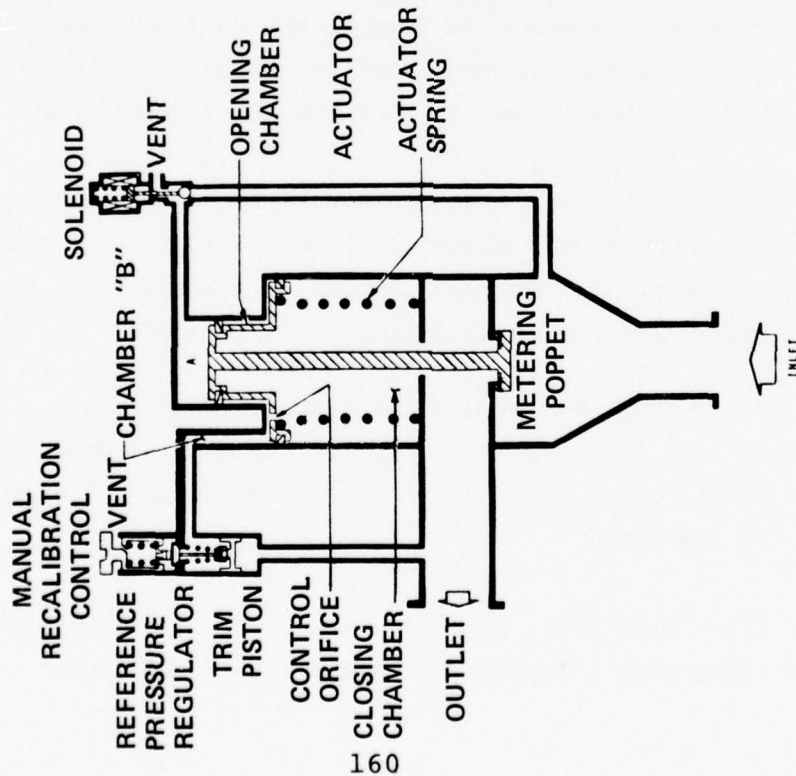

Figure A-19. Schematic diagram of the PASS pressure regulator and shutoff valve.

⊙ BLOWDOWN TEST WITH CONSTANT
AREA ORIFICE PER FIGURE A-21

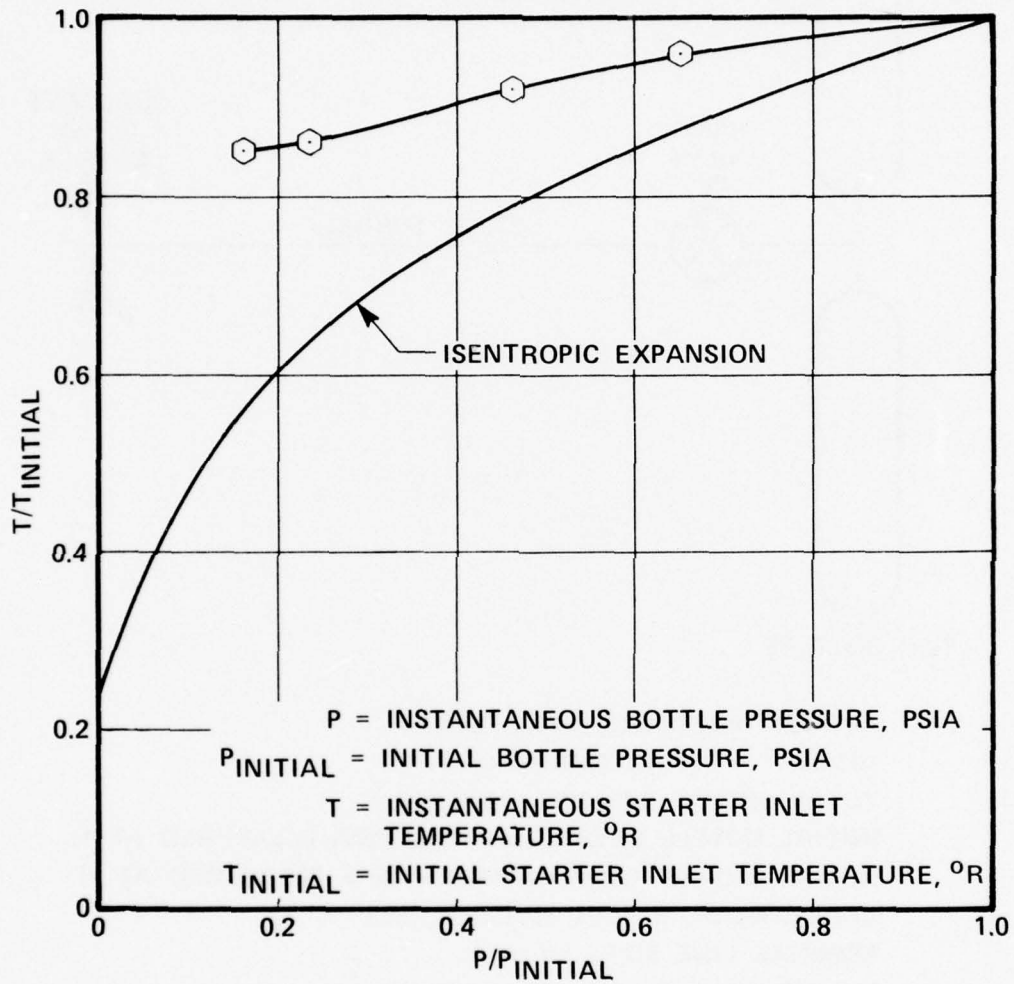
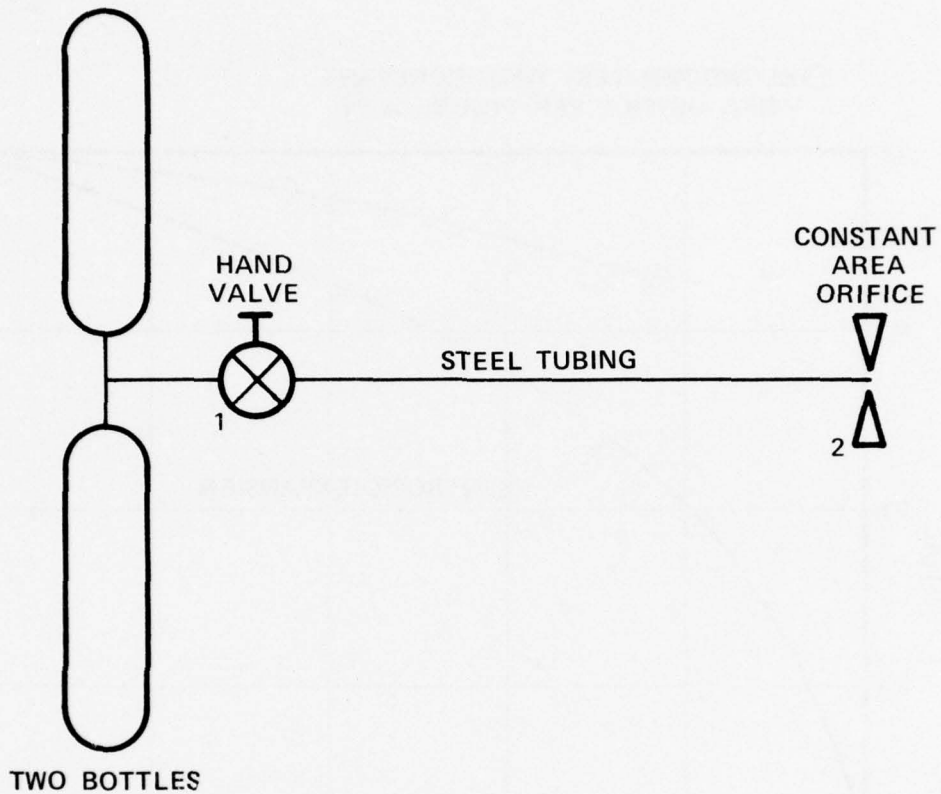

Figure A-20. Comparison of experimental bottle blowdown test data with isentropic expansion.



TWO BOTTLES
 AMBIENT PRESSURE = 14.1 PSIA
 AMBIENT TEMPERATURE = 87°F
 TOTAL BOTTLE VOLUME = 1300 IN.³
 INITIAL BOTTLE PRESSURE = 1150 PSIA (MEASURED AT 1)
 INITIAL BOTTLE TEMPERATURE = 86°F (MEASURED AT 2)
 LINE LENGTH: 8 FEET (STEEL TUBE)
 NOMINAL LINE SIZE: 1.0 INCH
 TUBING WALL THICKNESS: 0.035 INCH
 LINE BENDS: 90 DEGREES TOTAL

Figure A-21. Blowdown through constant area orifice test setup.

APPENDIX B

DRAWINGS

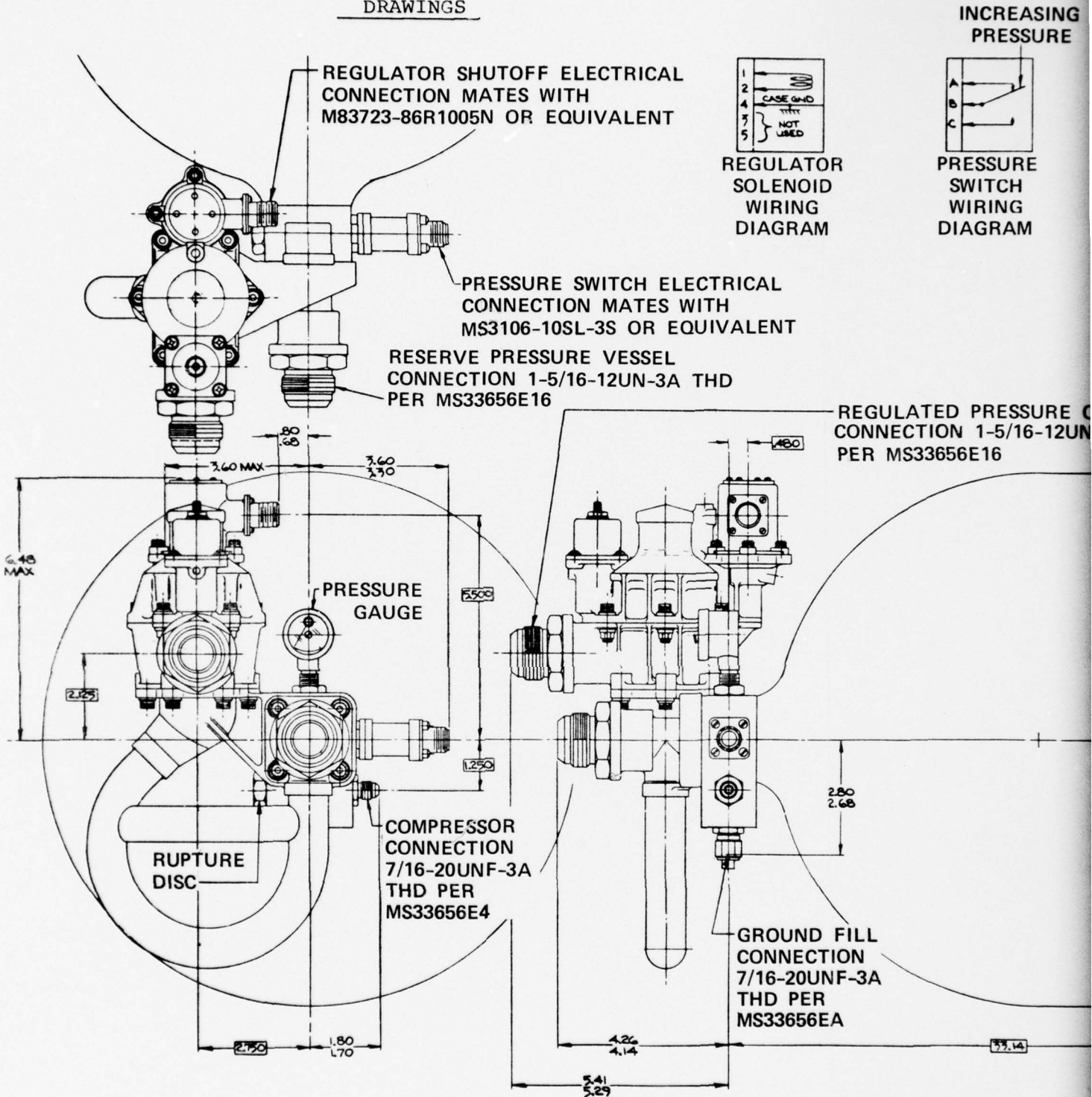

Figure B-1. Primary pressure vessel/manifold assembly (3400 in.³).

REGULATOR SOLENOID POWER: 1.2 AMP MAX. AT 20 VDC AT 70°F,
VOLTAGE RANGE 18 TO 30 VDC

REGULATED PRESSURE: 240 ±10 PSIG

REGULATOR IS SPRING LOADED CLOSED. ENERGIZE SOLENOID TO OPEN.

BURST PRESSURE: 3520 PSIG

PROOF PRESSURE: 2660 PSIG

RUPTURE DISC BURST POINT: 2000 ± 200 PSIG

MAXIMUM PRESSURE, DECAY PER DAY, AT 1000 PSIG: 5 PSI

PRESSURE SWITCH:

SWITCH POINT, INCREASING: 1050 PSIG

SWITCH POINT, DECREASING: 900 PSIG

ELECTRICAL RATING: 3 AMP INDUCTIVE AT 30 VDC

AMBIENT TEMPERATURE: -65°F to +160°F

OPERATING TEMPERATURE: -65°F TO +350°F

MAXIMUM OPERATING PRESSURE: 1600 PSIG

NORMAL OPERATING PRESSURE: 1000 PSIG

OPERATING MEDIUM: AIR OR NITROGEN

INCREASING
PRESSURE

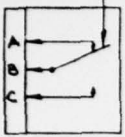

PRESSURE
SWITCH
WIRING
DIAGRAM

REGULATED PRESSURE OUTLET
CONNECTION 1-5/16-12UN-3A THD
PART NUMBER MS33656E16

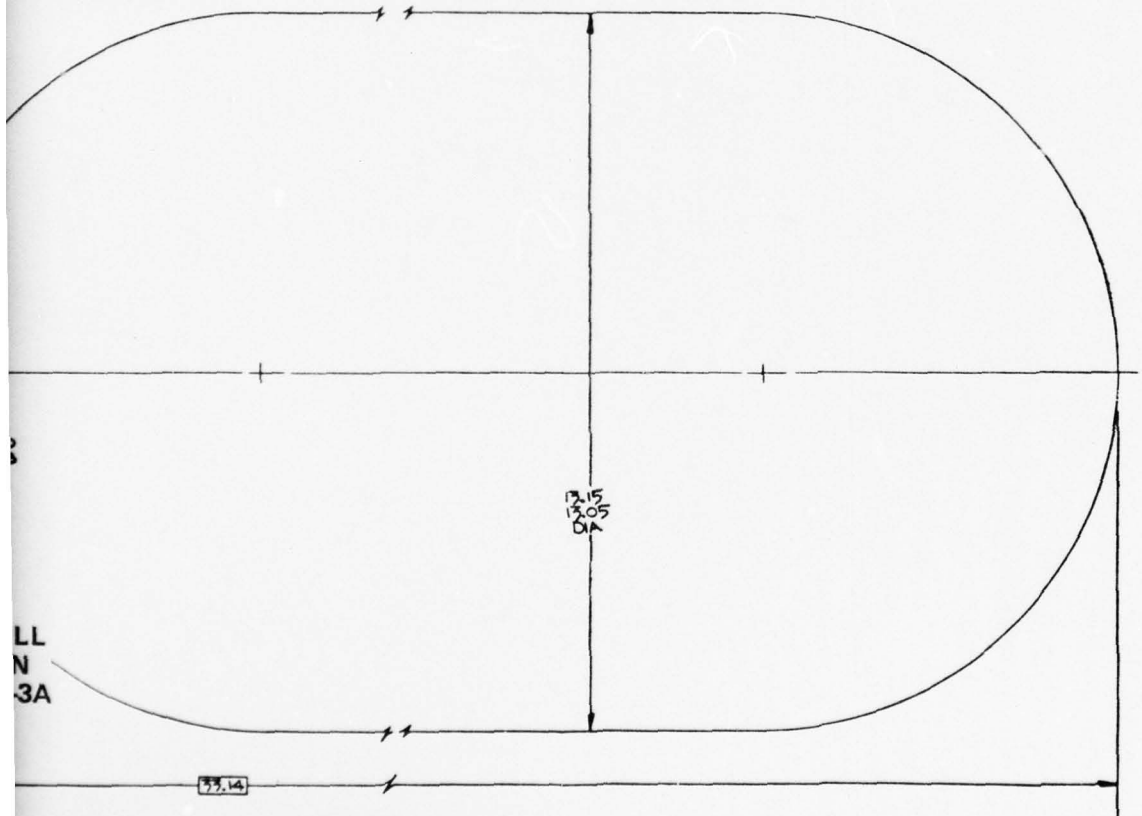

BURST PRESSURE: 3520 PSIG
PROOF PRESSURE: 2660 PSIG
RUPTURE DISC BURST POINT: 2000 ± 200 PSIG
MAXIMUM PRESSURE DECAY PER DAY, AT 1000 PSIG: 5 PSI
PRESSURE SWITCH:
SWITCH POINT, INCREASING: 1050 PSIG
SWITCH POINT, DECREASING: 900 PSIG
ELECTRICAL RATING: 3 AMP INDUCTIVE AT 30 VDC

AMBIENT TEMPE
OPERATING TEM
MAXIMUM OPER
NORMAL OPERA
OPERATING MED

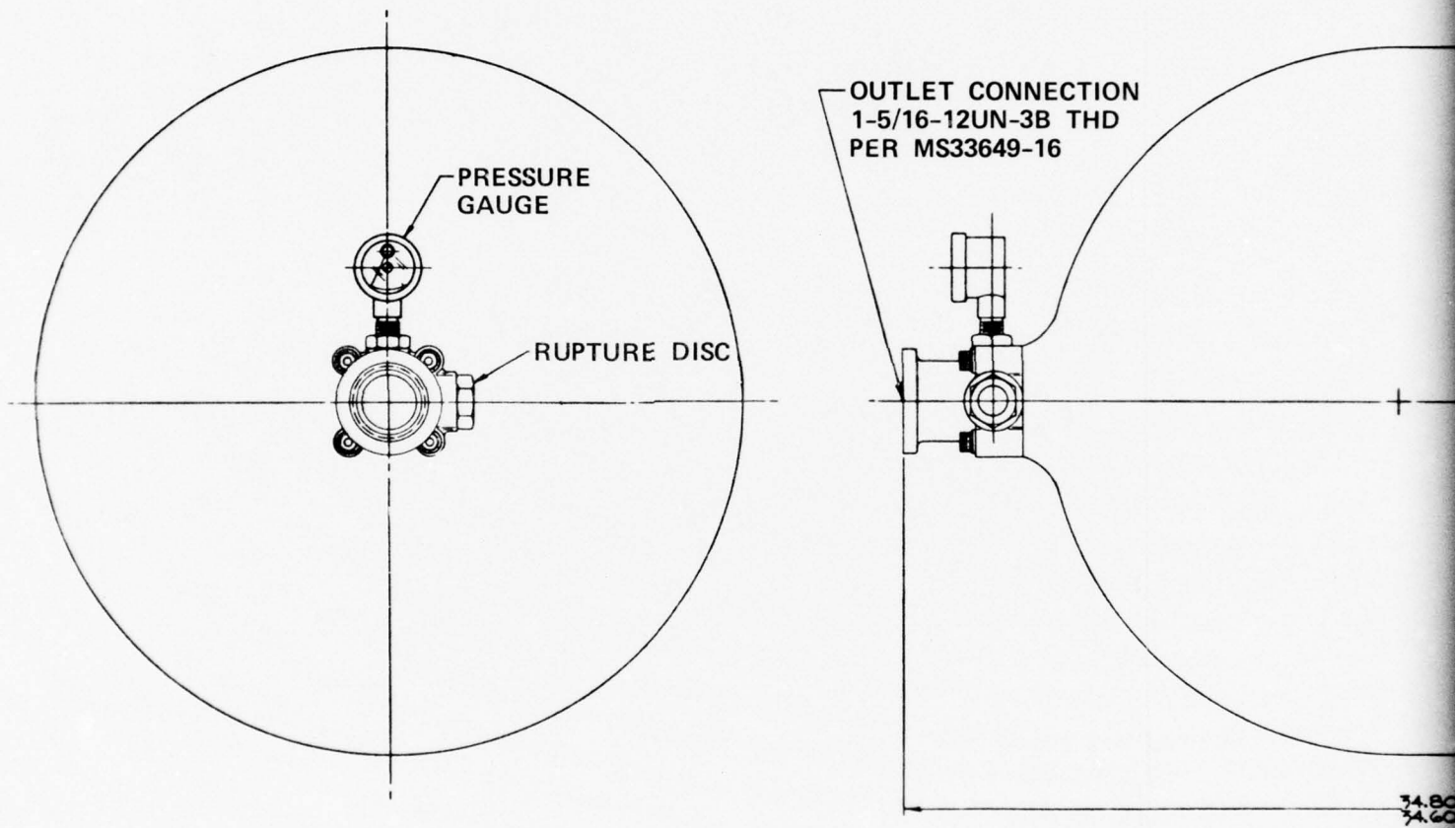
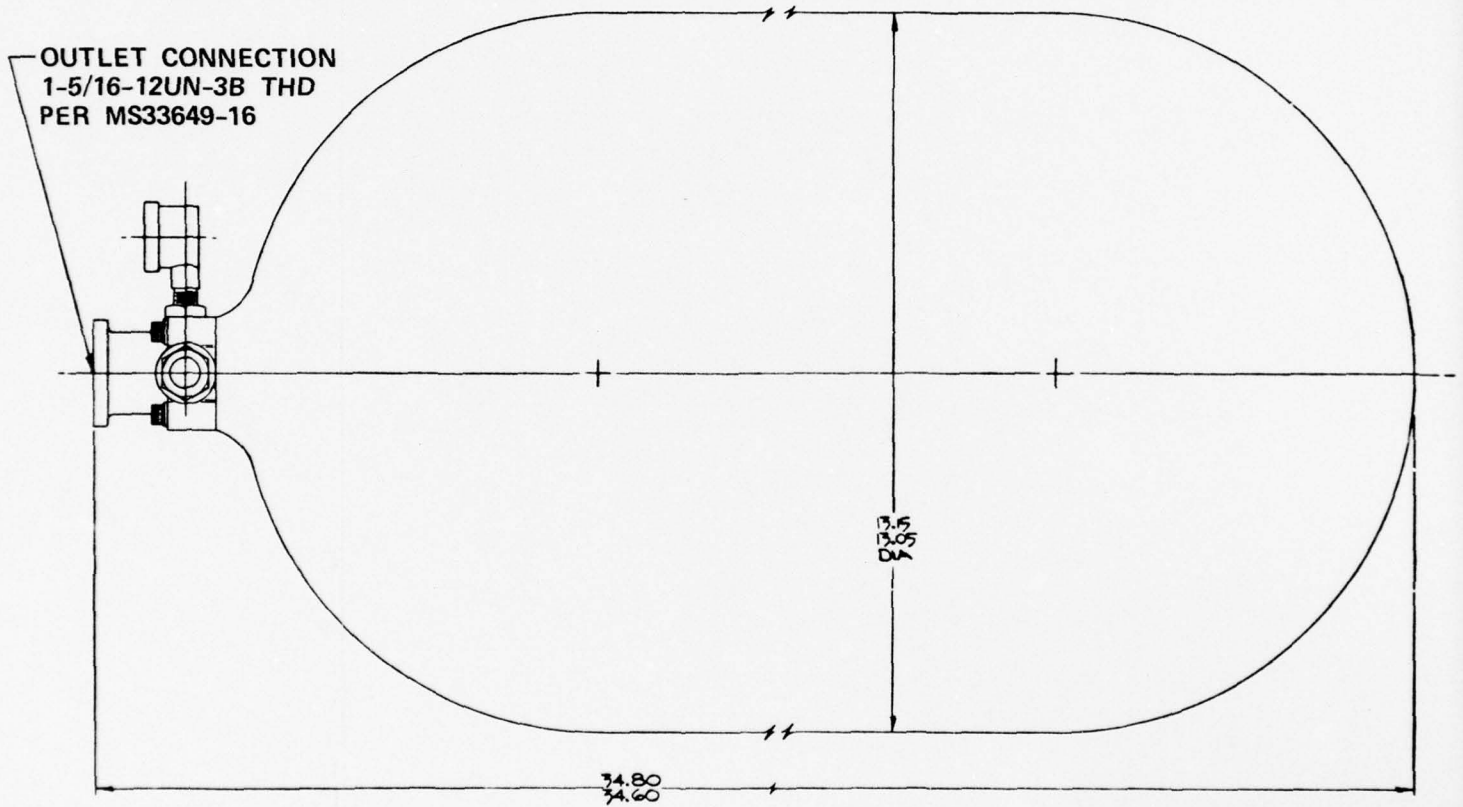

Figure B-2. Reserve pressure vessel/manifold assembly (3400 in.³).

PSIG
PSIG
INT: 2000 ± 200 PSIG
AY PER DAY, AT 1000 PSIG: 5 PSI
SING: 1050 PSIG
SING: 900 PSIG
3 AMP INDUCTIVE AT 30 VDC

AMBIENT TEMPERATURE: -65°F TO +160°F
OPERATING TEMPERATURE: -65°F TO +350°F
MAXIMUM OPERATING PRESSURE: 1600 PSIG
NORMAL OPERATING PRESSURE: 1000 PSIG
OPERATING MEDIUM: AIR OR NITROGEN



essel/manifold
)

160

2

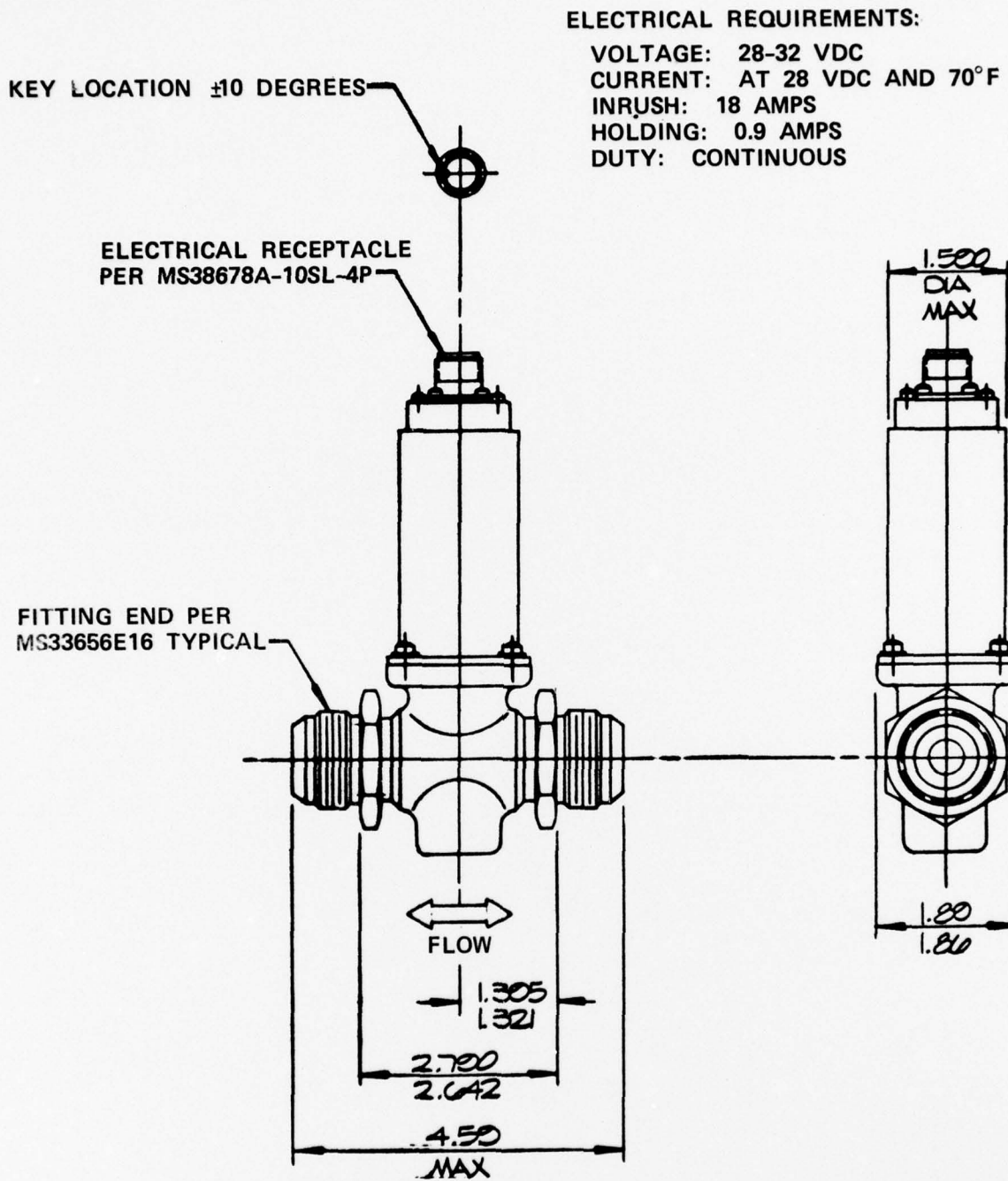

Figure B-3. Solenoid shutoff valve.

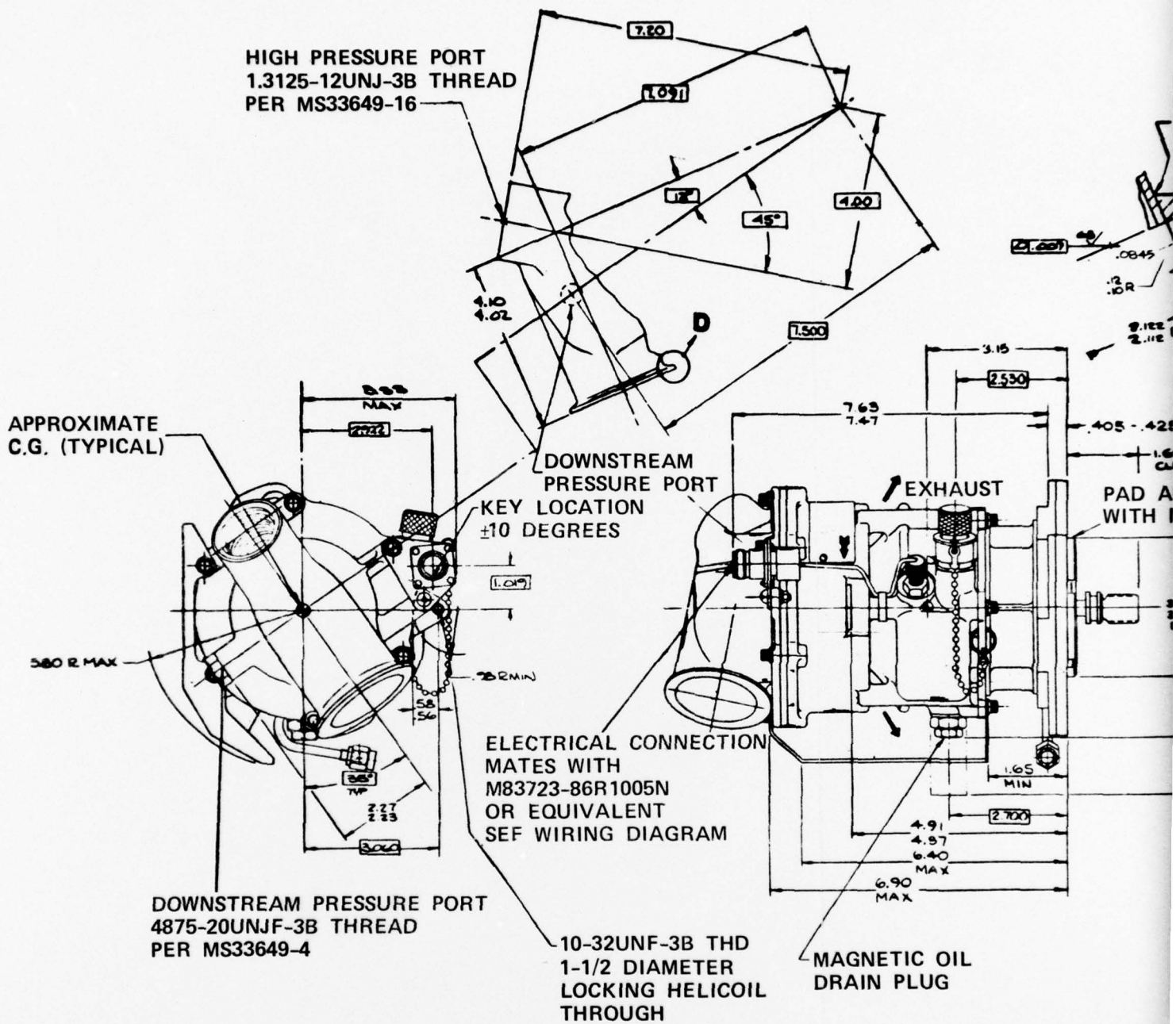
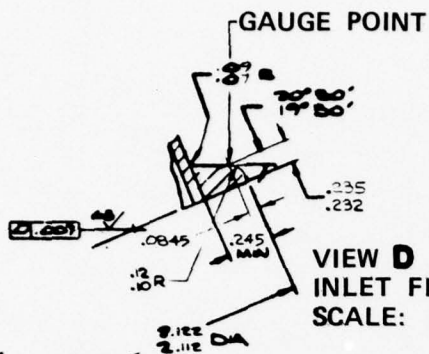
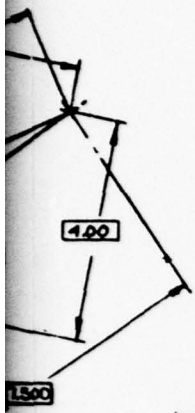
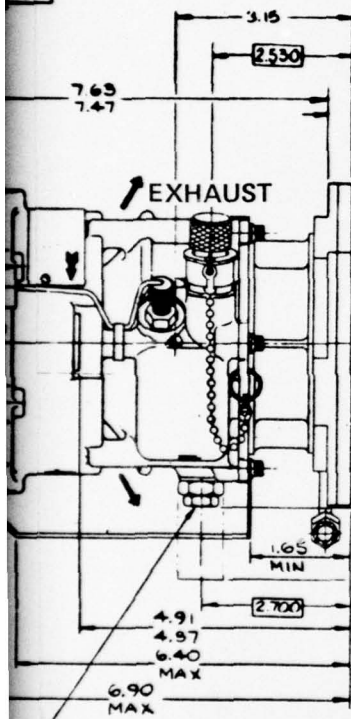

Figure B-4. Air turbine starter.



VIEW D
INLET FLANGE
SCALE: NONE



PAD AND SPLINE MATES
WITH MS3326-2

OIL FILLER CAP

5.30 MIN. REMOVAL
CLEARANCE

342-.352 DIA 4 PLACES THRU

1.62 MAX REMOVAL
CLEARANCE

620-.635 DIA
4 PLACES THRU

15° TYP

15° TYP

3.47

3.37

5.000 DIA B.C.

1.28

1.24

36 R MAX

(TYP)

2.06 MAX

3.63 MAX

2.80 MAX

DIRECTION OF ROTATION
OF OUTPUT SHAFT

DRAIN CONNECTION
MATES WITH MS33656-3

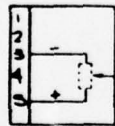

MAGNETIC
PICKUP (REF)

WIRING
DIAGRAM

170

2

DUTY CYCLE: 1 MINUTE OPEN FOLLOWED BY 1 MINUTE CLOSED, OR,
 2 MINUTES OPEN FOLLOWED BY 5 MINUTES CLOSED

UNIT WILL BE FULL OPEN BETWEEN 17 AND 26 PSIG TO MINIMIZE PRESSURE DROP
 UNIT REGULATED DOWNSTREAM PRESSURE TO 40 ± 2 PSIG WITH INLET
 PRESSURE FROM 38 TO 50 PSIG

INLET TEMPERATURE: 500F (MAXIMUM)
 INLET PRESSURE RANGE: 20 TO 55 PSIG
 AMBIENT TEMPERATURE: -65°F TO 275°F OPERATING
 -65°F TO 325°F NON-OPERATING

THIS UNIT IS SPRING LOADED CLOSED WHEN THE SOLENOID IS DE-ENERGIZED.
 ENERGIZE THE SOLENOID TO GO ON REGULATION.

BURST PRESSURE
 PROOF PRESSURE
 POSITION IN
 WHEN THE VALVE
 POSITION IN
 CURRENT OF
 SOLENOID ON
 SOLENOID OFF
 TOTAL LEAKAGE
 PORT LEAKAGE

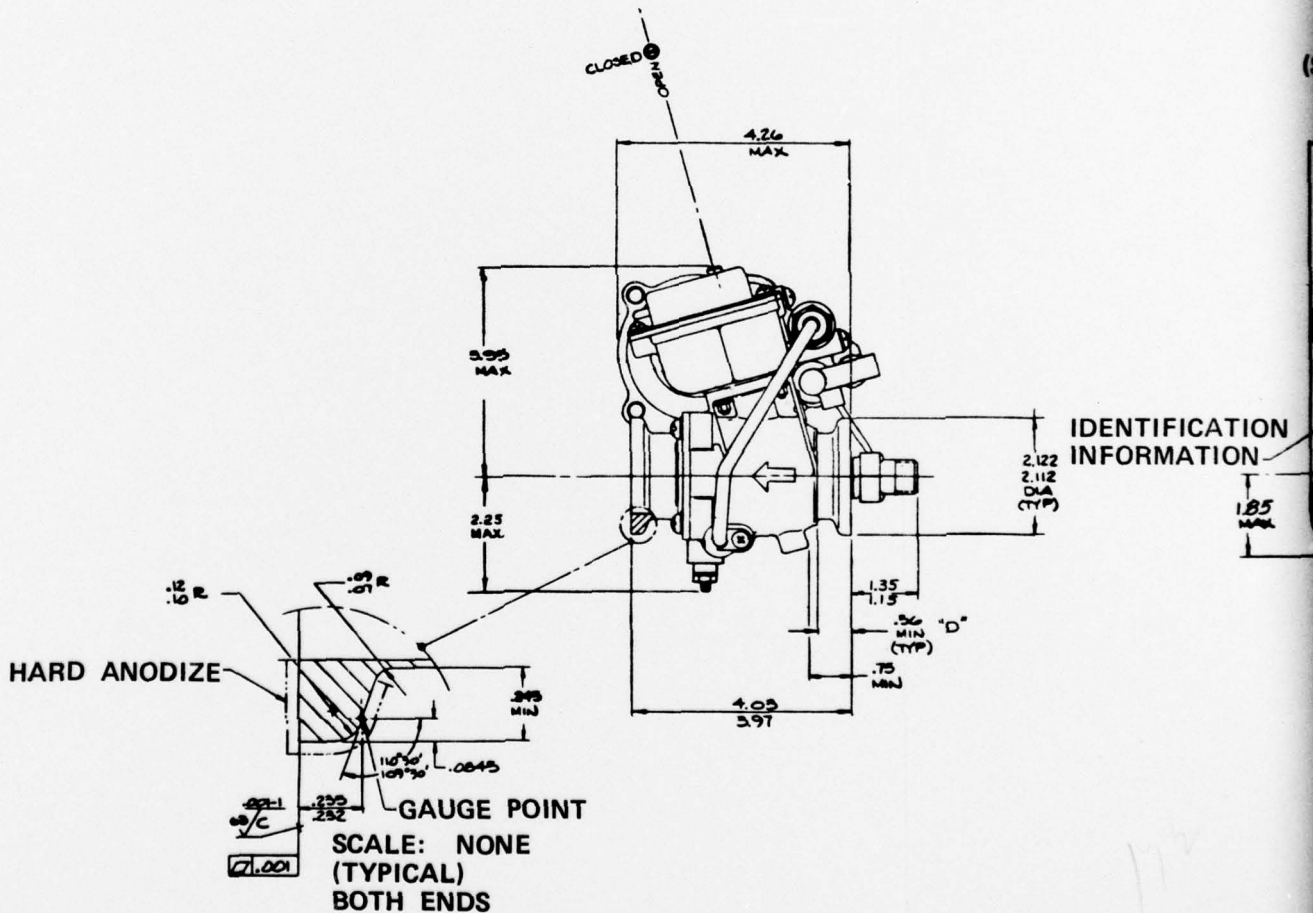

Figure B-5. Starter control valve.

BURST PRESSURE: 165 PSIG AT 500°F

PROOF PRESSURE: 110 PSIG AT 500°F

POSITION INDICATOR SWITCH IS AS SHOWN IN THE WIRING DIAGRAM
WHEN THE VALVE IS FULLY CLOSED (WITHIN 0-3 DEGREES)

POSITION INDICATOR SWITCH: 16-30 VDC MAXIMUM INRUSH
CURRENT OF 4.0 AMPERES

SOLENOID OPERATING CURRENT: 1.0 AMP MAXIMUM AT 30 VDC AT 70°F

SOLENOID OPERATING VOLTAGE: 16-30 VDC

TOTAL LEAKAGE: 0.40 LB/MIN MAX. AT 55 PSIG INLET PRESSURE AT 80°F

PORT LEAKAGE: 0.20 LB/MIN MAX. AT 55 PSIG INLET PRESSURE AT 80°F

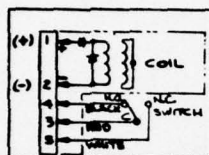

WIRING DIAGRAM
(SHOWN DE-ENERGIZED)

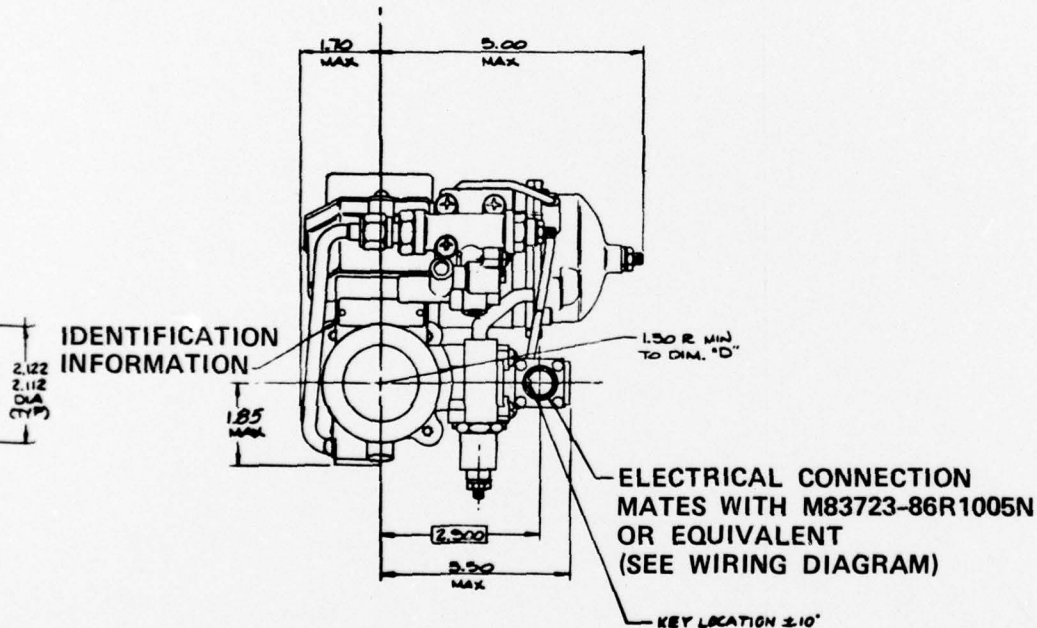

IDENTIFICATION
INFORMATION

ELECTRICAL CONNECTION
MATES WITH M83723-86R1005N
OR EQUIVALENT
(SEE WIRING DIAGRAM)

KEY LOCATION 2.10"

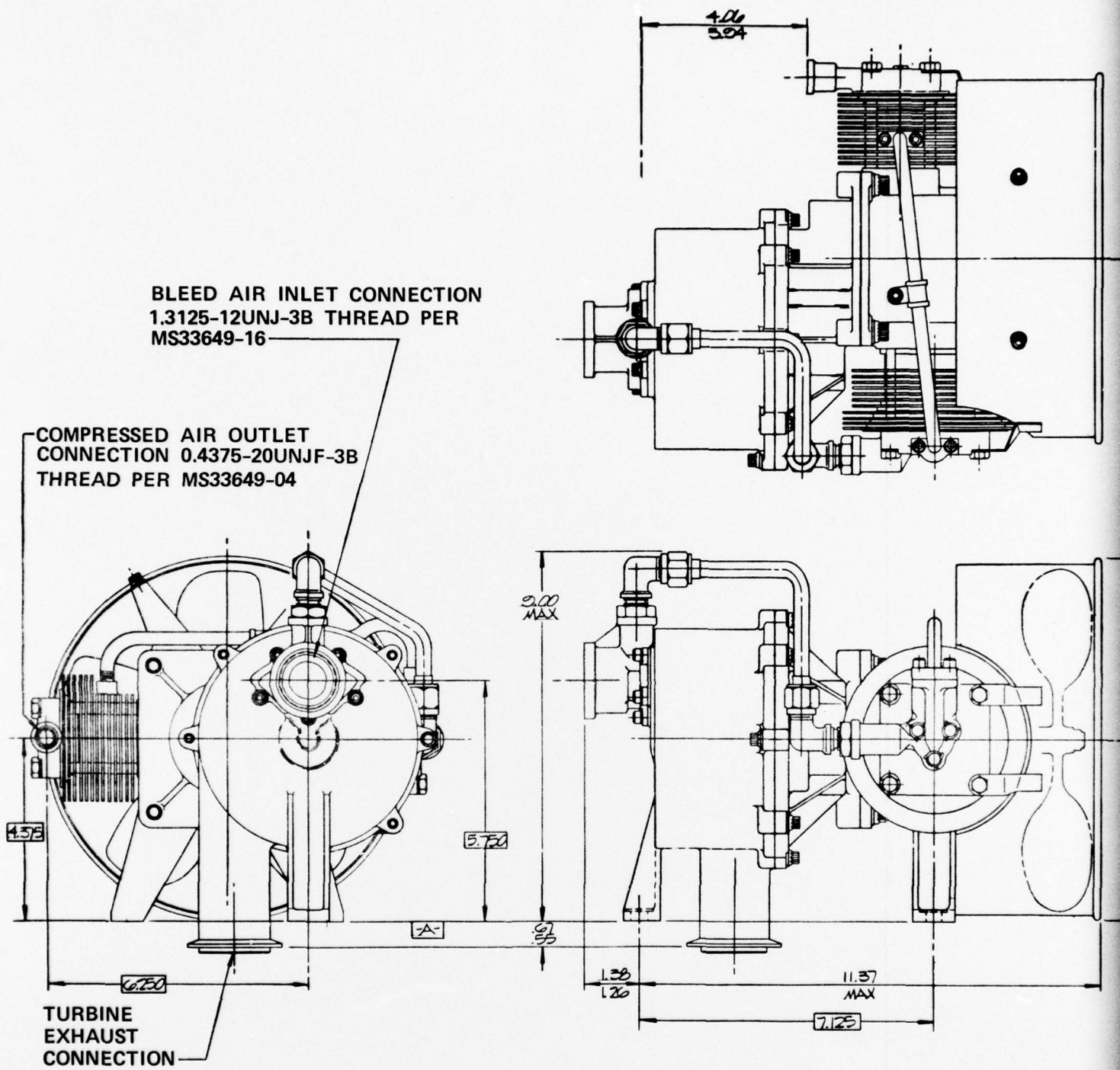
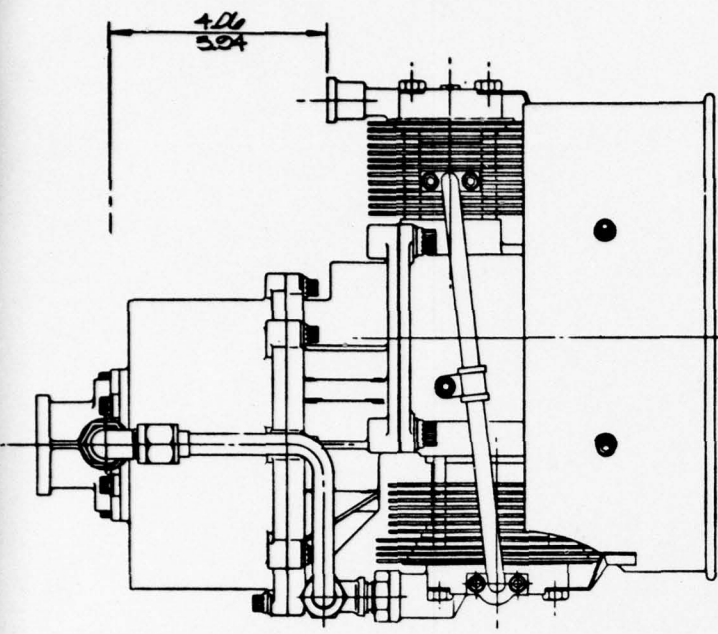
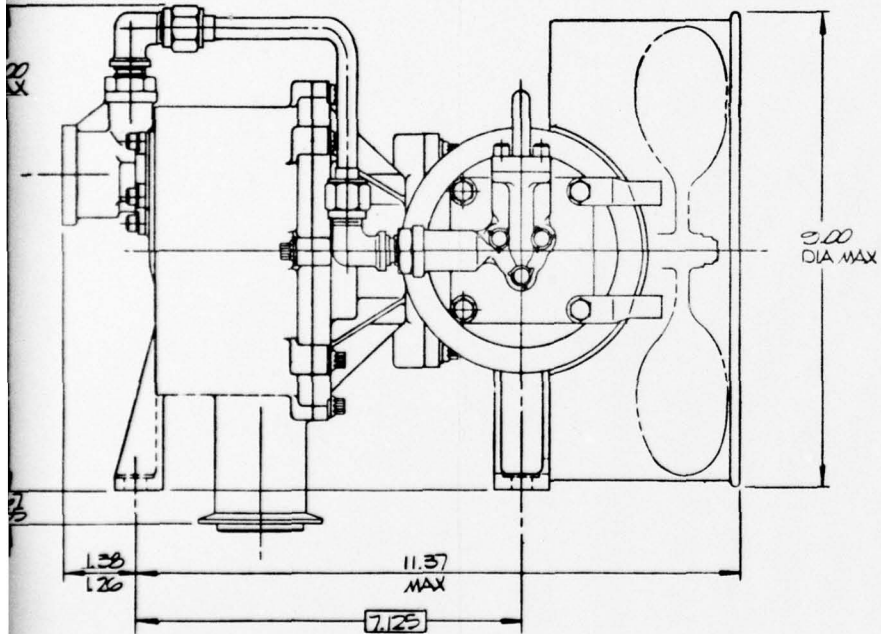

Figure B-6. Recharge compressor.



← COMPRESSOR COOLING
FAN AIRFLOW



2.00
DIA MAX

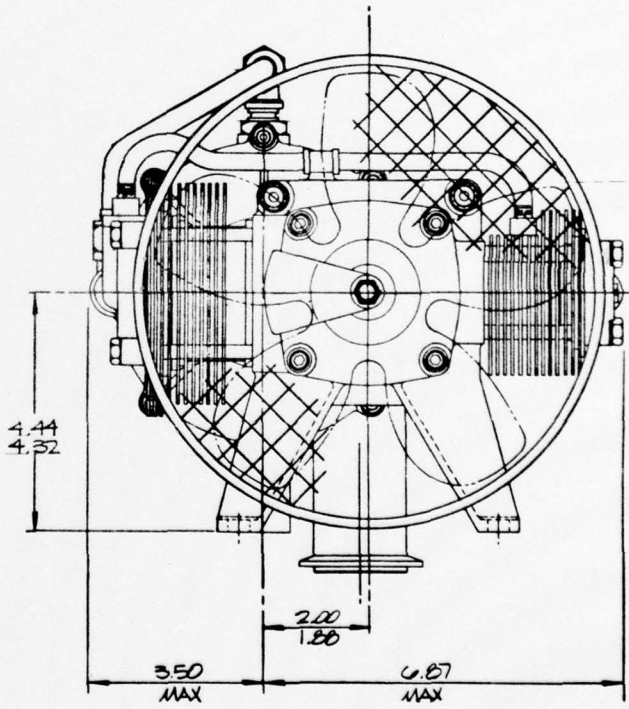

essor.

174

2

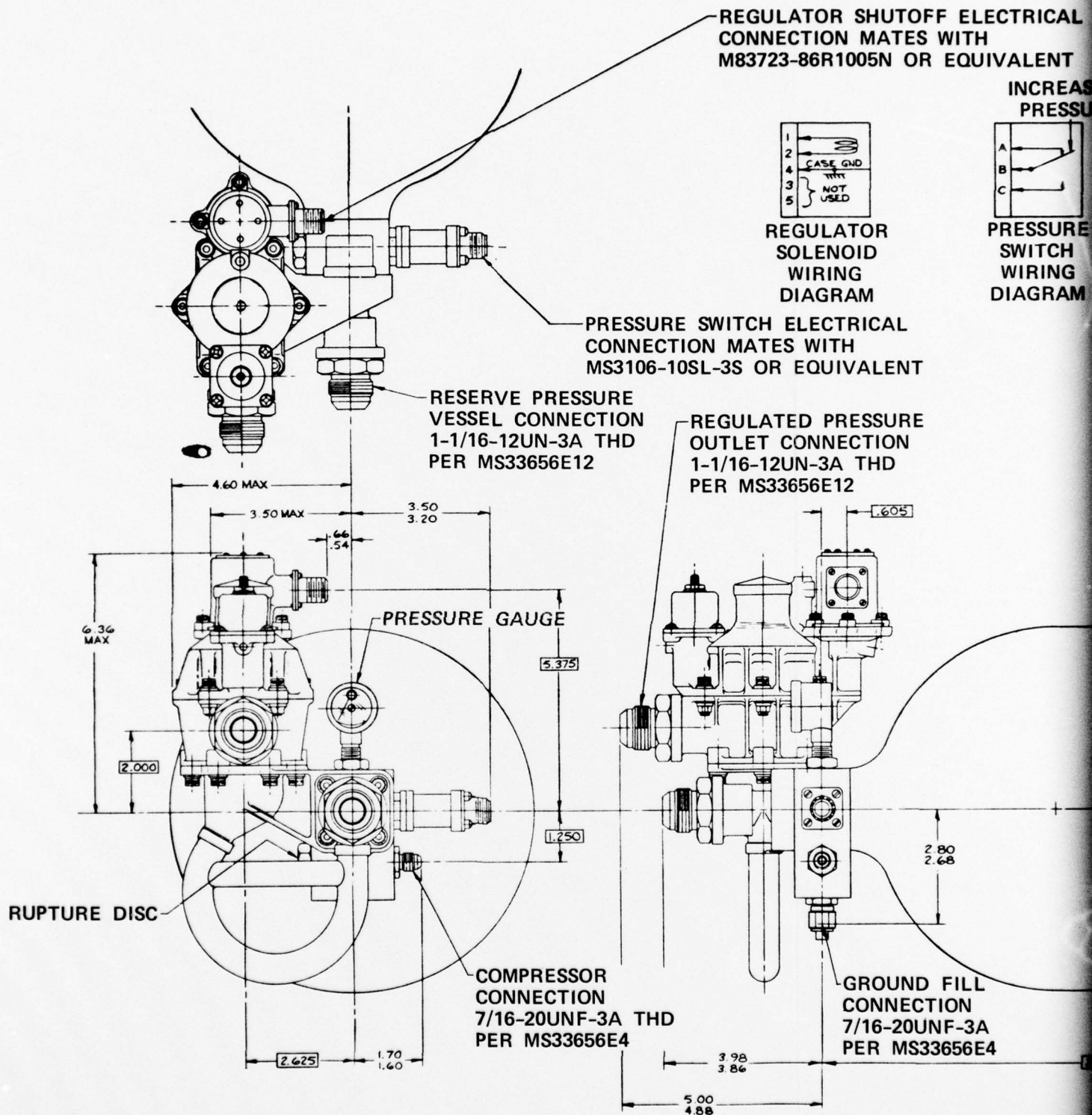

1

Figure B-7. Primary pressure vessel/manifold assembly (1000 in.³).

FOR SHUTOFF ELECTRICAL
CONNECTION MATES WITH
BR1005N OR EQUIVALENT



REGULATOR
SOLENOID
WIRING
DIAGRAM
ELECTRICAL
WITH
EQUIVALENT

INCREASING
PRESSURE

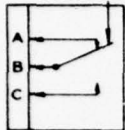

PRESSURE
SWITCH
WIRING
DIAGRAM

PRESSURE
CONNECTION
7/16-20 THD
3E12

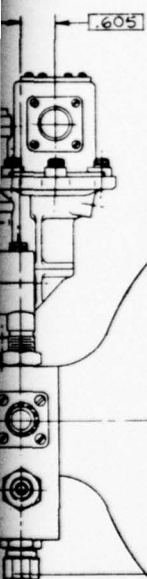

REGULATOR SOLENOID POWER: 1.2 AMP MAX. AT 28 VDC AT 70°F.
VOLTAGE RANGE 18 TO 30 VDC

REGULATED PRESSURE: 240 ±10 PSIG

REGULATOR IS SPRING LOADED CLOSED. ENERGIZE SOLENOID TO OPEN.

BURST PRESSURE: 3520 PSIG

PROOF PRESSURE: 2660 PSIG

RUPTURE DISC BURST POINT: 2000 ± 200 PSIG

MAXIMUM PRESSURE DECAY PER DAY, AT 1000 PSIG: 5 PSI

PRESSURE SWITCH:

SWITCH POINT, INCREASING: 1050 PSIG

SWITCH POINT, DECREASING: 900 PSIG

ELECTRICAL RATING: 3 AMP INDUCTIVE AT 30 VDC

AMBIENT TEMPERATURE: -65°F AT +160°F

OPERATING TEMPERATURE: -65°F TO +350°F

MAXIMUM OPERATING PRESSURE: 1600 PSIG

NORMAL OPERATING PRESSURE: 1000 PSIG

OPERATING MEDIUM: AIR OR NITROGEN

GROUND FILL
CONNECTION
7/16-20UNF-3A
PER MS33656E4

2.80
2.68

8.92
8.84
DIA

22.69

2

BURST PRESSURE: 3520 PSIG
PROOF PRESSURE: 2660 PSIG
RUPTURE DISC BURST POINT: 2000 ±200 PSIG
MAXIMUM PRESSURE DECAY PER DAY, AT 1000 PSIG: 5 PSI

AMBIENT TEMPERATURE: -
OPERATING TEMPERATURE:
MAXIMUM OPERATING PRESSURE:
NORMAL OPERATING PRESSURE:
OPERATING MEDIUM: AIR

PRESSURE SWITCH

SWITCH POINT, INCREASING: 1050 PSIG
SWITCH POINT, DECREASING: 900 PSIG
ELECTRICAL RATING: 3 AMP INDUCTIVE AT 30 VDC

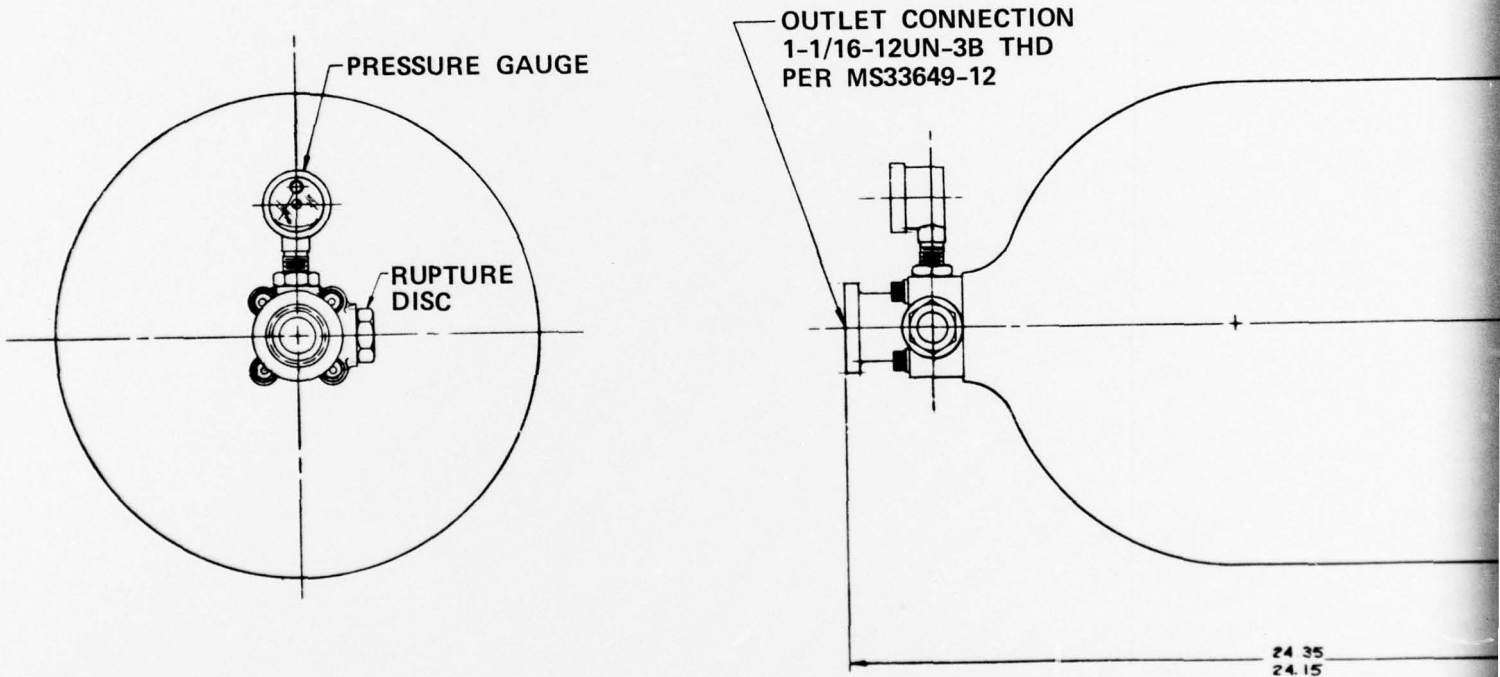
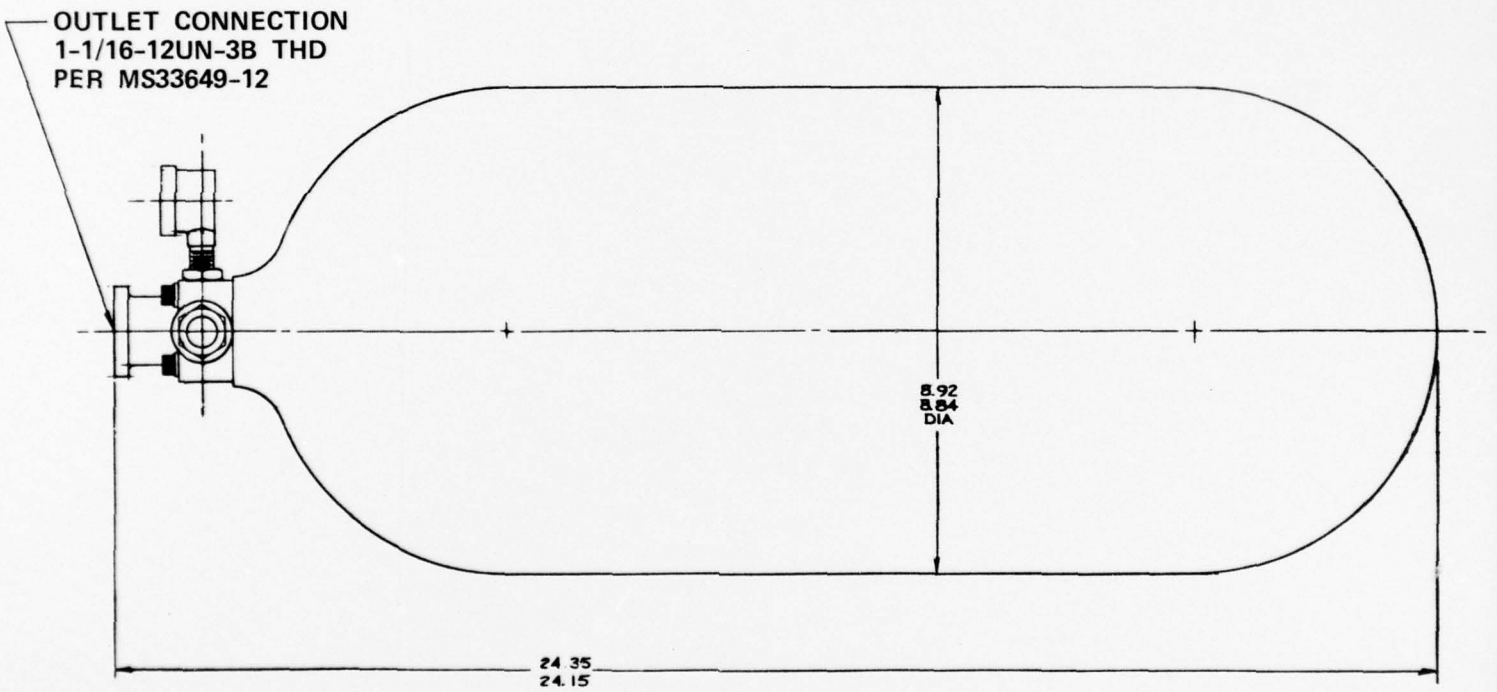

Figure B-8. Reserve pressure vessel/manifold assembly (1000 in.³).

AMBIENT TEMPERATURE: -65°F TO 160°F
OPERATING TEMPERATURE: -65°F TO +350°F
MAXIMUM OPERATING PRESSURE: 1600 PSIG
NORMAL OPERATING PRESSURE: 1000 PSIG
OPERATING MEDIUM: AIR OR NITROGEN

±200 PSIG
AY, AT 1000 PSIG: 5 PSI

050 PSIG
000 PSIG
INDUCTIVE AT 30 VDC



are vessel/manifold
(in.³).

198

2

ELECTRICAL REQUIREMENTS:

VOLTAGE: 28-32 VDC
CURRENT: AT 28 VDC AND 70°F
INRUSH: 18 AMPS
HOLDING: 0.9 AMPS
DUTY: CONTINUOUS

KEY LOCATION ± 10 DEGREES

ELECTRICAL RECEPTACLE
PER MS38678A-10SL-4P

FITTING END PER
MS33656E12
(TYPICAL)

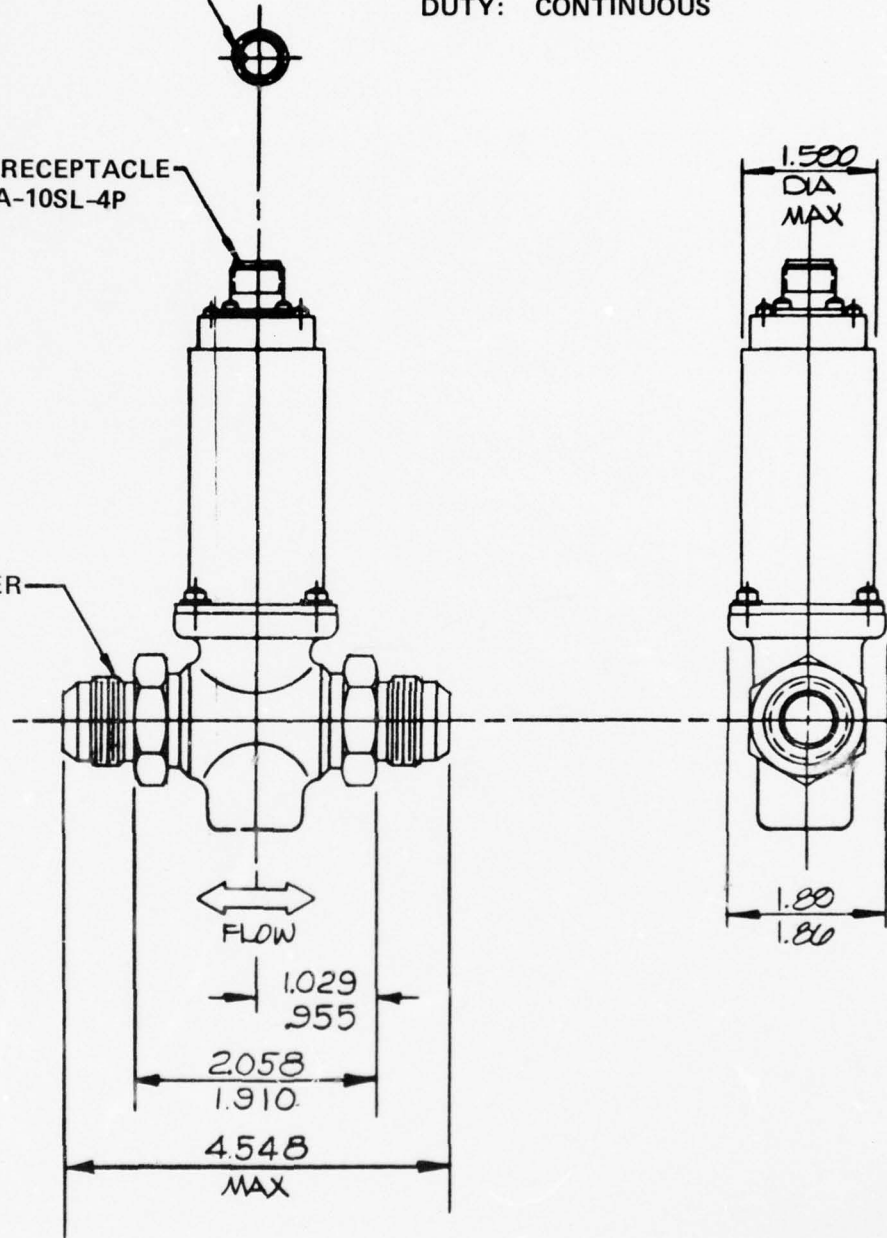

Figure B-9. Solenoid shutoff valve.

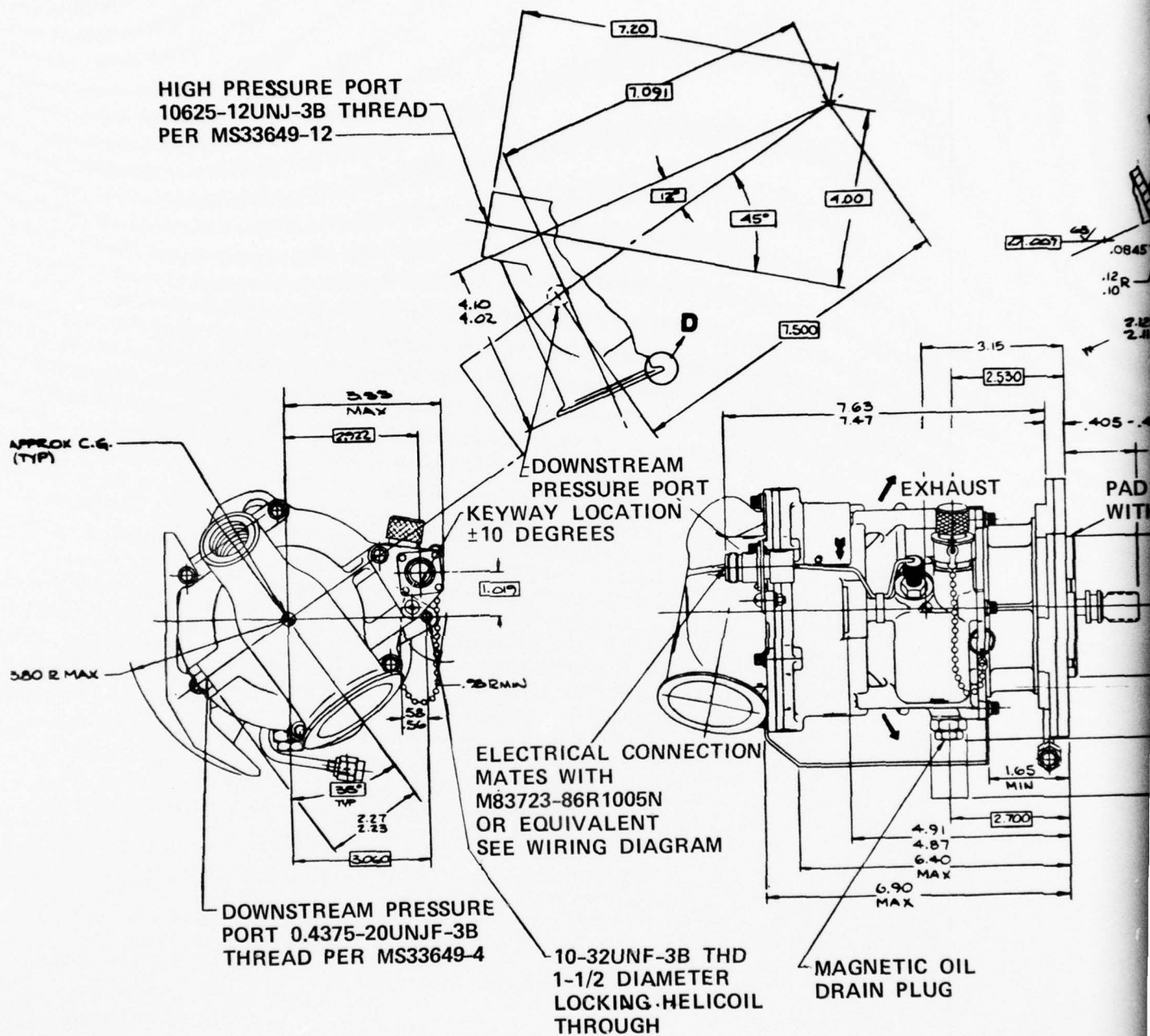
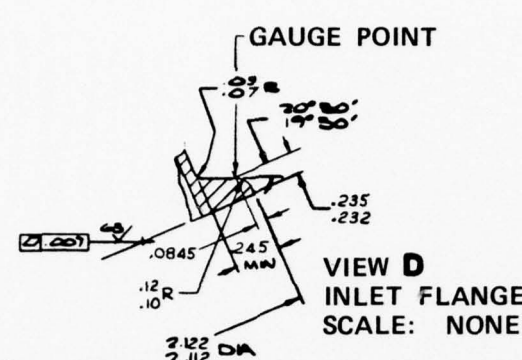
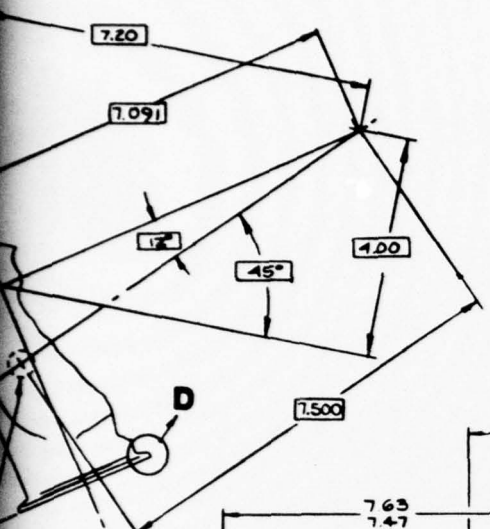

Figure B-10. Air turbine starter.



DOWNSTREAM
PRESSURE PORT
LOCATION
GREENS

FLUIDIC CONNECTION
WITH
MS361005N
BIVALENT
RING DIAGRAM

10-32UNF-3B THD
1-1/2 DIAMETER
LOCKING HELICOIL
THROUGH

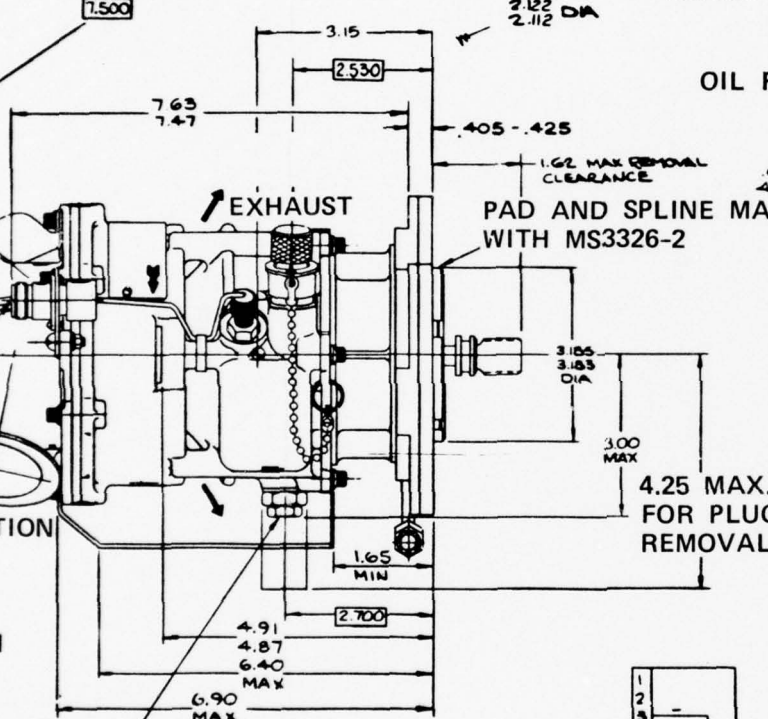

MAGNETIC OIL
DRAIN PLUG

OIL FILLER CAP

.620-.635 DIA
4 PLACES THRU

5.000 DIA B.C.

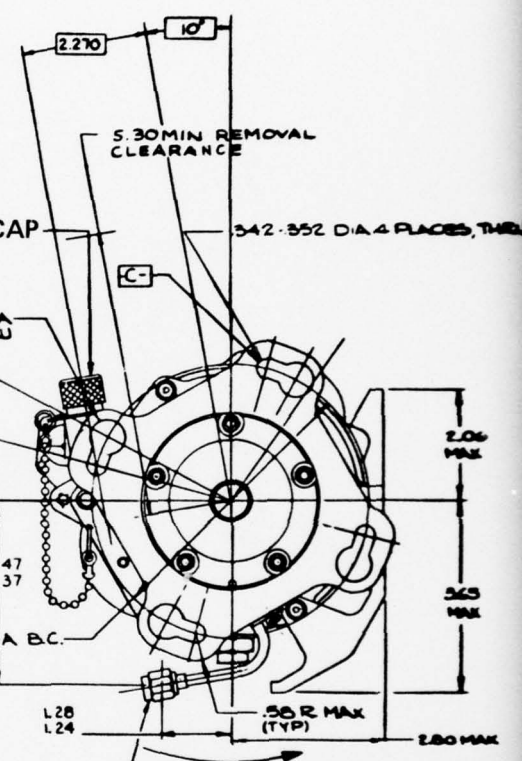
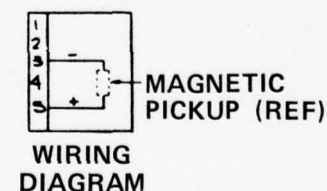

DIRECTION OF ROTATION
OF OUTPUT SHAFT

DRAIN CONNECTION
MATES WITH MS33656-3

starter.

13922-77

2