

AD-A052 123

DEFENSE SYSTEMS MANAGEMENT COLL FORT BELVOIR VA  
PROPOSED IMPROVEMENT IN NAVELEX PROCUREMENT FLOW PROCESS. (U)  
NOV 77 M R WENZ

F/G 15/5

UNCLASSIFIED

NL

1 OF 1

AD  
A062 123



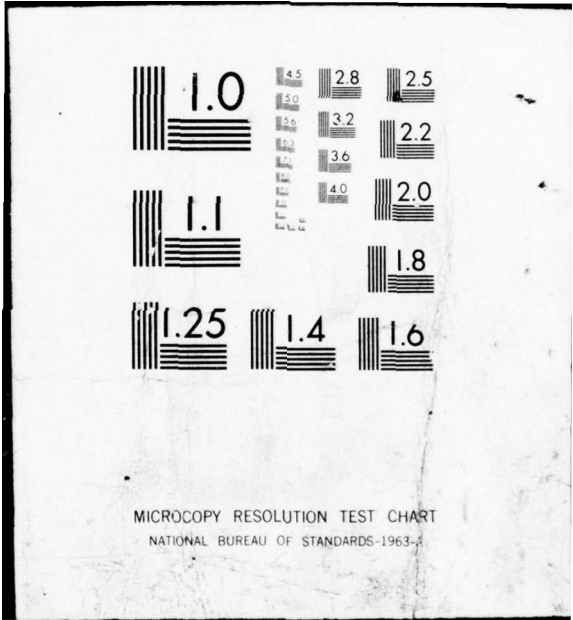

1

AD-A052123

# DEFENSE SYSTEMS MANAGEMENT COLLEGE



## PROGRAM MANAGEMENT COURSE INDIVIDUAL STUDY PROGRAM

PROPOSED IMPROVEMENT IN NAVELEX  
PROCUREMENT FLOW PROCESS

STUDY PROJECT REPORT  
PMC 77-2

Mary Ryan Wenz  
GS-12 USN

DDC  
RECEIVED  
APR 4 1978  
D

FORT BELVOIR, VIRGINIA 22060

**DISTRIBUTION STATEMENT A**

Approved for public release  
Distribution Unlimited

REPORT DOCUMENTATION PAGE		READ INSTRUCTIONS BEFORE COMPLETING FORM
1. REPORT NUMBER	2. GOVT ACCESSION NO.	3. RECIPIENT'S CATALOG NUMBER
4. TITLE (and Subtitle) <p style="text-align: center;">PROPOSED IMPROVEMENT IN NAVELEX PROCUREMENT FLOW PROCESS</p>		5. TYPE OF REPORT & PERIOD COVERED <p style="text-align: center;">Study Project Report 77-2</p>
7. AUTHOR(s) <p style="text-align: center;">MARY RYAN WENZ</p>		6. PERFORMING ORG. REPORT NUMBER
9. PERFORMING ORGANIZATION NAME AND ADDRESS <p style="text-align: center;">DEFENSE SYSTEMS MANAGEMENT COLLEGE FT. BELVOIR, VA 22060</p>		8. CONTRACT OR GRANT NUMBER(s)
11. CONTROLLING OFFICE NAME AND ADDRESS <p style="text-align: center;">DEFENSE SYSTEMS MANAGEMENT COLLEGE FT. BELVOIR, VA 22060</p>		10. PROGRAM ELEMENT, PROJECT, TASK AREA & WORK UNIT NUMBERS
14. MONITORING AGENCY NAME & ADDRESS (if different from Controlling Office)		12. REPORT DATE <p style="text-align: center;">1977-2</p>
		13. NUMBER OF PAGES <p style="text-align: center;">40</p>
		15. SECURITY CLASS. (of this report) <p style="text-align: center;">UNCLASSIFIED</p>
		15a. DECLASSIFICATION/DOWNGRADING SCHEDULE
16. DISTRIBUTION STATEMENT (of this Report) <p style="text-align: center;">UNLIMITED</p>		
<div style="border: 1px solid black; padding: 5px; display: inline-block;"> <p><b>DISTRIBUTION STATEMENT A</b></p> <p>Approved for public release; Distribution Unlimited</p> </div>		
17. DISTRIBUTION STATEMENT (of the abstract entered in Block 20, if different from Report)		ACCESSION for
		NYIS      White Section <input checked="" type="checkbox"/> DDC      Buff Section <input type="checkbox"/> UNANNOUNCED <input type="checkbox"/> JUSTIFICATION..... BY..... DISTRIBUTION/AVAILABILITY CODES Dist. ATAIL and/or SPECIAL
18. SUPPLEMENTARY NOTES		
19. KEY WORDS (Continue on reverse side if necessary and identify by block number) <p style="text-align: center;">SEE ATTACHED SHEET</p>		<div style="border: 1px solid black; padding: 10px; display: inline-block; font-size: 2em; font-weight: bold;">A</div>
20. ABSTRACT (Continue on reverse side if necessary and identify by block number) <p style="text-align: center;">SEE ATTACHED SHEET</p>		

DEFENSE SYSTEMS MANAGEMENT COLLEGE

STUDY TITLE: A PROPOSED IMPROVEMENT IN NAVELEX PROCUREMENT  
FLOW PROCESS

STUDY PROJECT GOALS: To describe a new acquisition methodology currently being implemented at NAVELEX to accelerate the procurement cycle.

STUDY REPORT ABSTRACT:

This report assesses the current procurement flow process in the Naval Electronics Systems Command. It describes a new procedure to streamline and reduce the acquisition cycle.

In preparing this study, a number of key managers in NAVELEX were interviewed, and a variety of reports, prepared by the Task Force assigned to this study, were reviewed.

The new procedure was implemented in October 1977. It is anticipated that the benefits will, to a large degree, be realized. Considerable potential exists for undertaking further management research aimed at understanding and improving the system acquisition process.

SUBJECT DESCRIPTORS:

Procurement Management, Major Policies and Organization, PRE-Contract Award Planning (10.07.01.02)

NAME, RANK, SERVICE  
Mary Ryan Wenz, GS-12, USN

CLASS  
PMC 77-2

DATE  
11-7-77

PROPOSED IMPROVEMENT IN NAVELEX  
PROCUREMENT FLOW PROCESS

Individual Study Program  
Study Project Report  
Prepared as a Formal Report

Defense Systems Management College  
Program Management Course  
Class 77-2

by

Mary Ryan Wenz  
GS-12            USN

November 1977

Study Project Advisor  
Dr. Joseph L. Hood

This study project report represents the views, conclusions and recommendations of the author and does not necessarily reflect the official opinion of the Defense Systems Management College or the Department of Defense.

## EXECUTIVE SUMMARY

The procurement cycle within the Department of Defense has lengthened considerably over the past 10 years. An increase in management reviews, test and evaluation, competitive prototyping, and low-rate initial production has reduced risks, but has also greatly increased the acquisition cycle cost and time.

In July 1977, the Naval Electronics Systems Command, as a result of a Zero Base Management Conference, undertook a study to accelerate the work flow process within its organization. A Task Force was assigned to review the current procedure, and to undertake a study to streamline this process. This report assesses this study which will shorten procurement lead time, assure early scheduling of events required for each procurement, and improve procurement management control procedures.

This report has been prepared in five parts. It traces the development of NAVELEX from 1966-77. Further it provides an overview of current procurement procedures, and the Task Force's recommendations to improve this process. It speculates on future evolutionary changes which may derive from this study. Lastly, it summarizes the findings of the ZBM group, and the prediction that the study will achieve its objectives. A year hence, the impact of the new work flow process can better be measured.

LIST OF ILLUSTRATIONS

Figure		Page
1.	NAVELEX Tetrahedron	4
2.	NAVELEX Matrix	6
3.	Typical Negotiated Procurements (Cycle Time)	11-13
4.	APC Decision Paper	19-20
5.	Proposed Work Flow	22-24

TABLE OF CONTENTS

EXECUTIVE SUMMARY. . . . .	ii
LIST OF ILLUSTRATIONS. . . . .	.iii
Chapter	Page
I. INTRODUCTION AND BACKGROUND	1
Purpose and Scope of Study Project	
Organization of Report	
II. NAVAL ELECTRONICS SYSTEM COMMAND	4
Concept of Operation	
Zero Base Management Conference	
III. CURRENT NAVELEX PROCUREMENT PROCESS	9
Historical Precedents	
ZBM Task Force	
IV. EVALUATION OF PROPOSED PROCEDURE	16
Strengths and Weaknesses	
Alternatives	
V. EVOLUTIONARY CHANGES	29
Preliminary Actions Necessary to	
Accommodate New Mode of Operation	
Consolidation of Functions	
VI. SUMMARY	33
Overview	
Recommendations	
VII. ADDITIONAL AREAS OF STUDY	35
BIBLIOGRAPHY	36

## Chapter I

### Introduction and Background

"The procurement cycle . . . is too long . . . Our own internal procedures, plus fact-finding and other required pre-contract procedures, leading to and during negotiations, make this cycle approximately 8 months long, on the average, for any large procurement and several months longer for very complex procurements. I can neither suggest nor foresee any real solution to this problem. As a military manager . . . I chafe at this lengthy process. But as a private citizen, I find reassuring a regulatory process so well designed to eliminate or at least minimize error of faulty judgment . . . Nevertheless, we are often forced into a letter contract when the demands of the program will not tolerate the response time of the procurement (contracting) cycle.<sup>1</sup>"

The above remarks, by Lt. General John W. O'Neill, former Deputy Commander, Air Force Systems Command, described the problem of the contracting cycle almost 10 years ago. Since then it has lengthened considerably and it has been criticized as requiring too much time and too many resources, from both the contractor and Government.

Within the last two months, the Naval Electronics Systems Command (NAVELEX) has undertaken a study to streamline and reduce the acquisition cycle. This report examines this study, prepared by a task force, to shorten procurement lead time, assure early scheduling of events required for each procurement, and to

---

<sup>1</sup>U.S. Congress, House, Committee on Government Operations, Government Procurement and Contracting (Part 4), Hearings before a Subcommittee of the House Committee on Government Operations, 91st Congress, 1st Session, 1969, p. 1239.

improve procurement management control procedures.

Further, this report assesses the current process, describes the new procedure, and looks into possible evolutionary changes for the future. The report then asks and answers the question, "How effective is the new procedure in accomplishing its objectives?"

The methodology utilized in preparing this study was to survey a variety of reports prepared by the Task Force assigned to this study, and to interview a number of key managers, whose work will be impacted by the new procedures. Considerable use was made of the results of the NAVELEX Zero Base Management Conference in July 1977 in Charlottesville, Virginia.

The author was personally involved in a predecessor organization which looked into the acceleration of the procurement cycle, in 1977, as a member of the Admiral's Productivity Group. By now, the cycle had lengthened considerably, and the author revised the PP, RAN & D&F Flow Chart. This traced the sequential steps in the procurement paper flow not only within NAVELEX, but also NAVMAT. This background provided an opportunity for an in-depth observation of the problems, as well as the benefits to be derived from a consolidated (shortened) procedural change.

This report has been prepared in five parts. Chapter II deals with the background of the Naval Electronics Systems Command. It traces its development over the past eleven years. The basis for the establishment of the ZBM Study group and its

findings are covered.

Chapter III provides a broad overview of the current NAVALEX procurement process from the initiation of a request by DDRE to contract award. It will include a brief assessment as to the need for a new study.

Chapter IV is an evaluation of the procedure, implemented on October 3, 1977. It reviews the Task Force's recommendations against a contemporary setting. It also assesses strengths and weaknesses, and examines some proposed alternatives.

Chapter V speculates on future evolutionary changes which might be expected, specifically the trend toward consolidation of specific functions; i.e. preparation of PRs, Procurement Plans, JANs, D&Fs. and the subsequent impact on contract management.

Chapter VI summarizes the findings, essentially that the benefits will, to a large degree, be realized. The chapter also reports that considerable potential exists for undertaking further management research aimed at understanding and improving system acquisition processes.

## Chapter II

### Naval Electronics Systems Command

NAVELEX, formerly a part of NAVORD, was established in 1966. This SYSCOM, under the Naval Material Command, is deeply involved in a variety of programs aimed at expanding the Fleet's capabilities. These include the development of command and control systems, introduction of satellite communications systems and automated communications systems into widespread Fleet use, production of precise electronic navigation systems and reliable automatic carrier landing systems, and continuing advances in all areas of electronic warfare.

The NAVELEX tetrahedron symbolically depicts the broad matrix of electronic systems and equipments required to support the Naval operating forces, and the command relationships between the various mission areas.

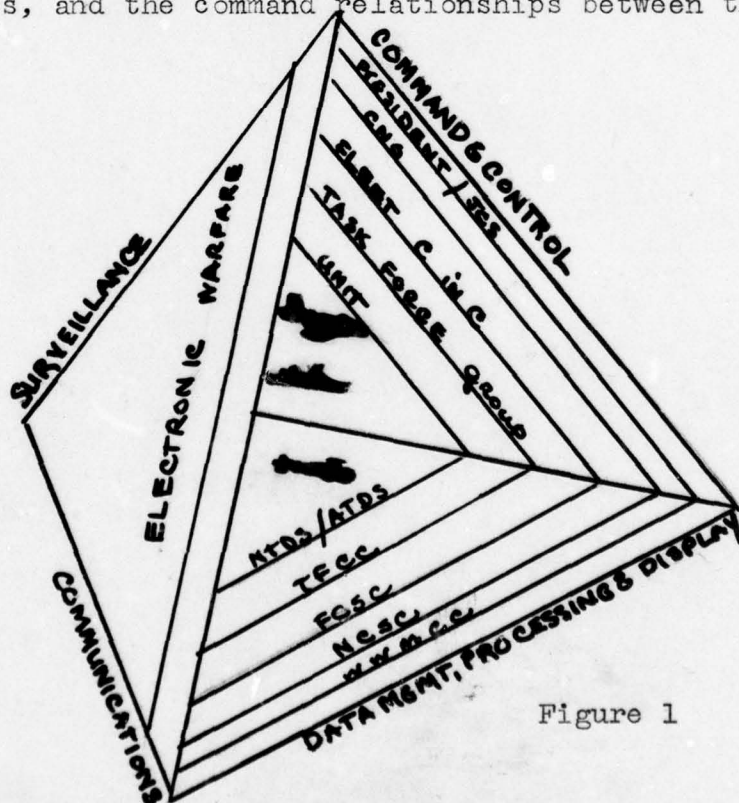

Figure 1

NAVELEX headquarters in Washington is organized on a matrix basis (see Figure 2). It is divided into five Directorates which manage different phases of equipment development from the "idea" stage through installation and maintenance to ultimate replacement.

These are:

- a. ELEX 01 - The Planning, Programming, and Resources Management Directorate. These are the "managers" who are responsible for providing overall direction. They are concerned with policy, planning and programming, progress appraisal and financial management.
- b. ELEX 02 - The Contracts Directorate. Here are the "buyers" who negotiate contracts for equipment and services required to fulfill the Command's primary mission to support the Fleet. These "buyers" are the link with industry and the "suppliers".
- c. ELEX 03 - The Research and Technology Directorate which guides the Command's efforts to develop the needs of tomorrow's Navy today. This involves programs in Naval Laboratories, as well as industry and research institutions.
- d. ELEX 04 - The Logistics Directorate, working with Command field activities worldwide, serves the Fleet. Logisticians assure that electronic equipment does the job it was designed and developed to do, under operating conditions. They are concerned with systems effectiveness, maintenance engineering and logistics support.

Source: Constructed by Author.

NAVAL ELECTRONIC, SYSTEMS COMMAND

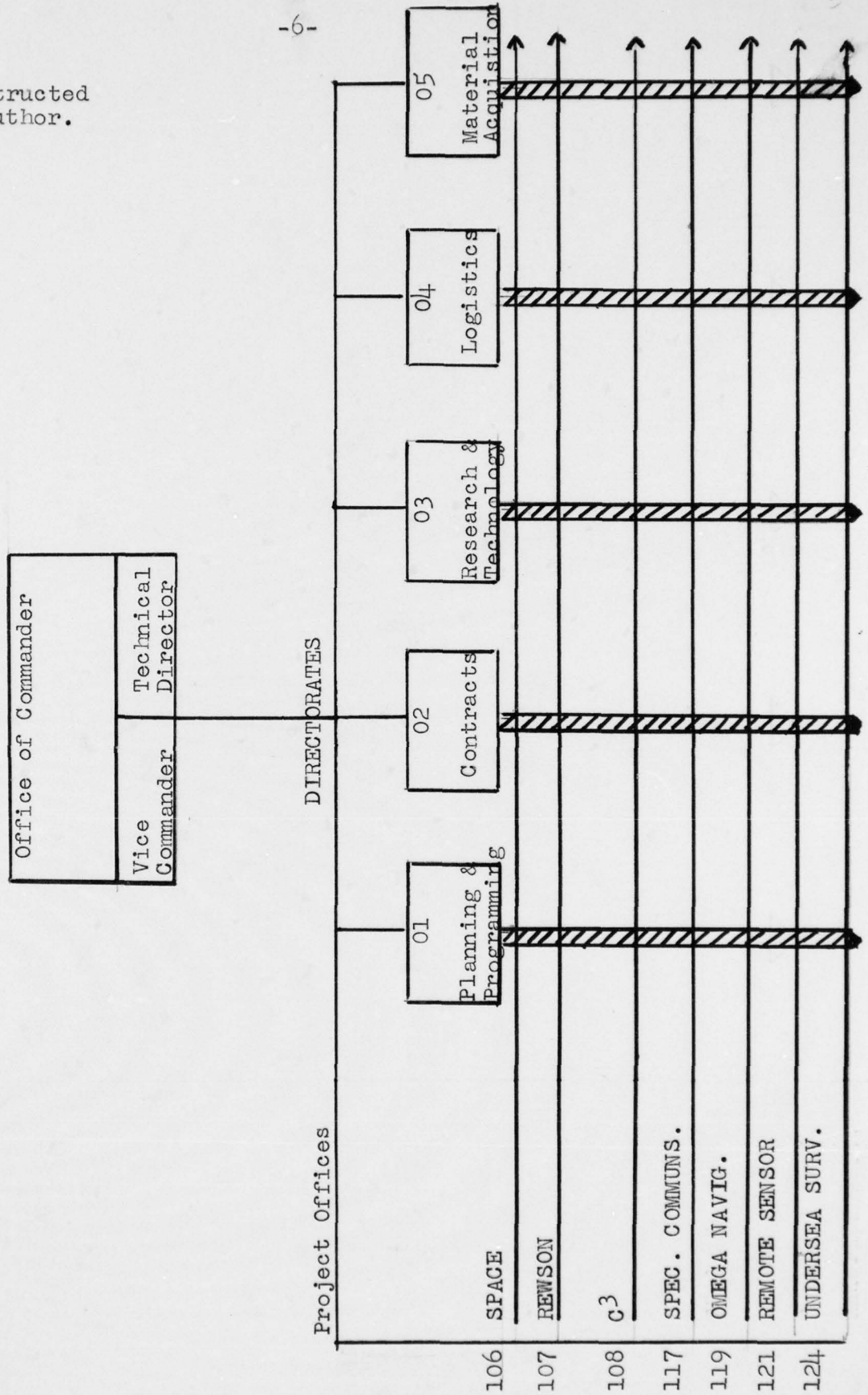

Figure 2 NAVELEX MATRIX

- e. ELEX 05 - Material Acquisition Directorate, whose responsibilities include engineering development, design, acquisition, test and evaluation, and certification of a wide range of electronic systems and hardware for installation worldwide at Naval air and communications stations and Marine Corps facilities, as well as shipboard.

Additionally, the command has Project Management Elements charged with developing equipment and systems to meet urgent needs in such areas as electronic warfare, communications, surveillance, navigation, sensors and space technology. These special project offices were established because of the cost, complexity, or priority in these areas. Eight field activities provide immediate response to remedy difficulties beyond the capability of the station work force. Further, the Command has a Systems Test and Evaluation Detachment in Maryland, a Security Engineering Center in Washington, and a Space Systems Activity in Los Angeles.

From an initial austere personnel complement, NAVELEX now numbers over 3000 people. Recent OSD mandates have curtailed new employment and replacements will not be forthcoming. NAVELEX managers are keenly aware of two organizational facts of life: limited resources, and the need for division of labor.

By way of background to the specific procedure described herein, a conference was held on 17-19 July 1977 at Charlottesville, Va. In addition to the Commander and his Deputy (both Rear Admirals), all Directorate Heads (O6 and above) plus their

high grade civilian Deputies attended this meeting. It was called the ZBM Retreat, for the Command had just gone through an extensive zero-base budgeting exercise. Two key issues surfaced during the meeting: anticipated reduced levels of manpower, and the need to exercise any unnecessary steps in the acquisition cycle.

### Chapter III

#### Current NAVELEX Procurement Process

The procurement process, currently in existence at NAVELEX, is cumbersome and lengthy. As Jacques S. Gansler, former Deputy ASD, stated:

"If one were to step back and look at the total acquisition cycle and the changes that have been brought about over the past 10 years, one could say that concurrency has been largely eliminated, and that significant steps have been taken towards reducing risks. However, we have added 'incremental decision-making', an increase in management reviews, considerable increase in test evaluation, competitive prototyping and low-rate initial production. Each of these additions has had the desired effects, but also greatly increased the acquisition cycle time and cost. The effect has been that while we were able to field the NIKE AJAX in 6 years, and the HAWK in 5 years (from the requirement to deployment) it is likely to take 18 years to field AEGIS."<sup>2</sup>

These comments were reinforced at a meeting with Congressman Richard H. Ichord, in a meeting with students of the Defense Systems Management College on September 18, 1977, on Capitol Hill. He spoke of the need for micro-management of the major weapons' systems acquisitions by Congress; however, the corollary aspect of costly extensions was shocking.

In NAVELEX, the Program Management Elements (PME's) are of the lean matrix type; that is, some of their staffs are experts in one or more disciplines, and each relies on the functional groups for support. One of the distinguishing characteristics of a typical manager is how dependent he is on

---

<sup>2</sup> Jacques S. Gansler, New Initiatives in Defense Systems' Acquisition, National Contract Management Assn: Washington, D.C. July 1976.

the activities of a variety of other people to perform his job effectively. A manager can be dependent, in varying degrees on superiors, subordinates, peers in other parts of the organization, the subordinates of peers, outside suppliers, customers, competitors, unions, regulating agencies and many others.<sup>3</sup> These dependency relationships are an inherent part of the managerial job. Without at least minimal cooperation from these groups, managers cannot guide their organizations toward achievement of their objectives.

In NAVELEX, as well as other DOD organizations, the manager's is dependent on many people (and things) whom they do not directly control, and who have limited time, energy and talent, for their competing demands. This is the key to one of the biggest frustrations a manager may feel in his job. In this context, the undertaking of a procedure to recognize these dependency relationships, and to improve the orderly flow of documents through the organization was a welcome project. In the words of one Program Manager, "NAVELEX is biased for 'stops'".

The current flow process appeared workable....on paper.(Fig.3) And the wickets had been defined several times, with a plethora of instructions as guidance. However, as each review board shredded the proposed acquisition, and demanded extensive rework

---

<sup>3</sup>John P. Kotter, "Power, Dependence and Effective Management", Harvard Business Review, July-August 1977, p. 126.





TYPICAL SINGLE SOURCE PROCUREMENT OVER \$1 MILLION  
 [TOTAL TIME: 135 DAYS (27 WEEKS)]

(N) = NUMBER OF DAYS REQUIRED

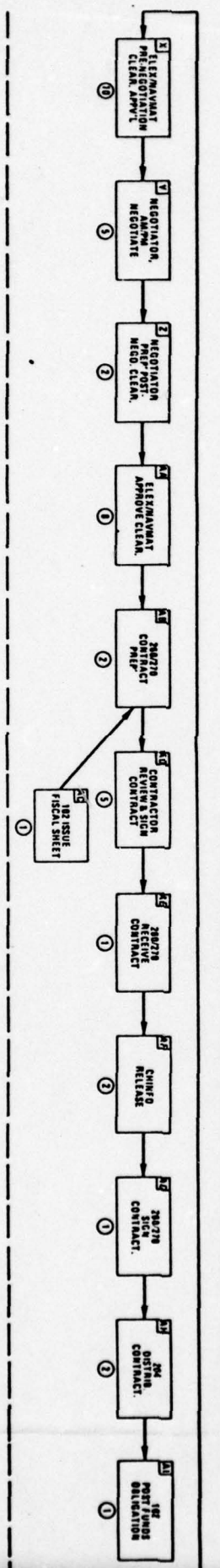
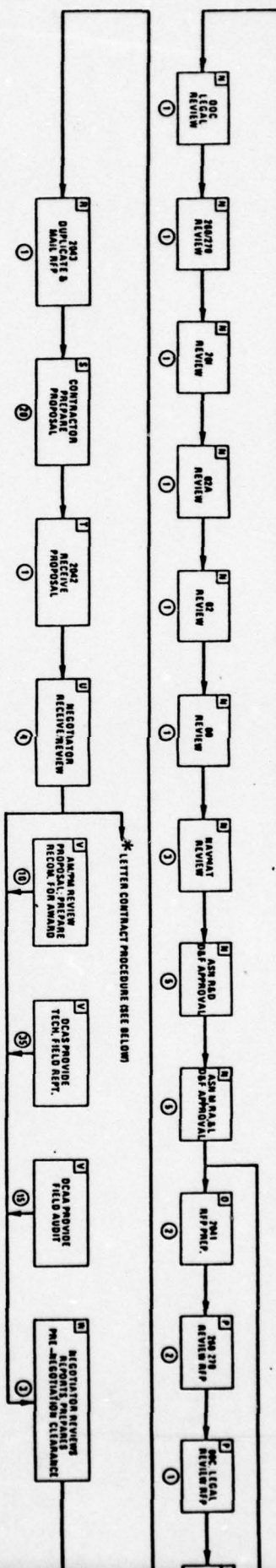
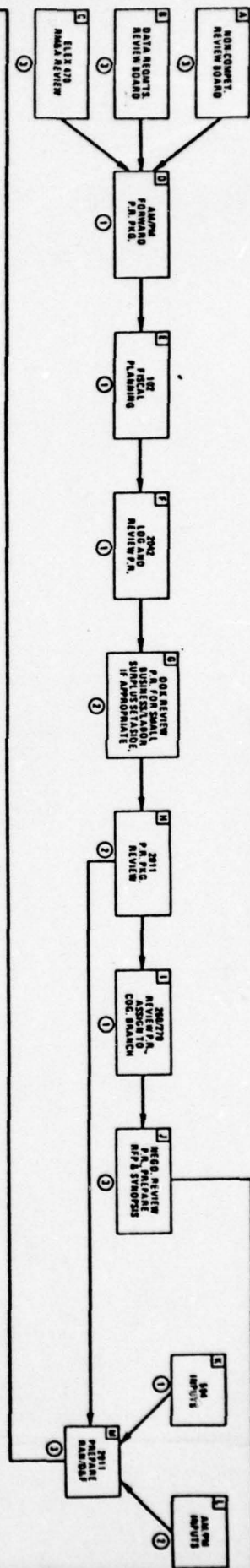

TYPICAL LETTER CONTRACT PROCEDURE  
 [TOTAL TIME: 70 DAYS (14 WEEKS)]

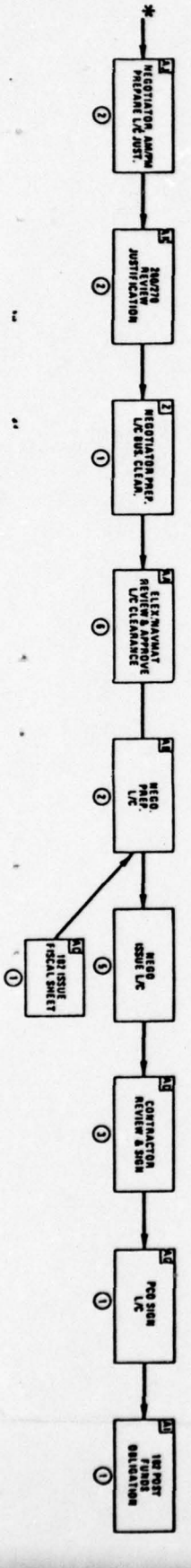



SUMMARY

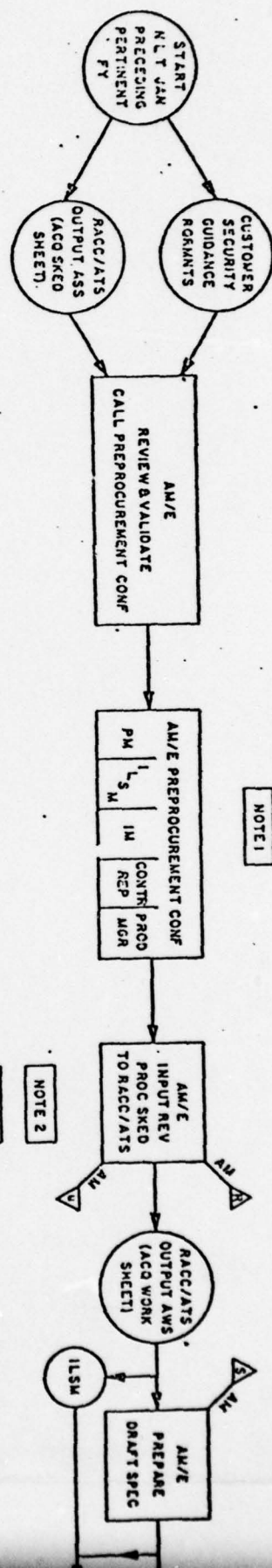

NOTE 1

NOTE 2

NOTE 3

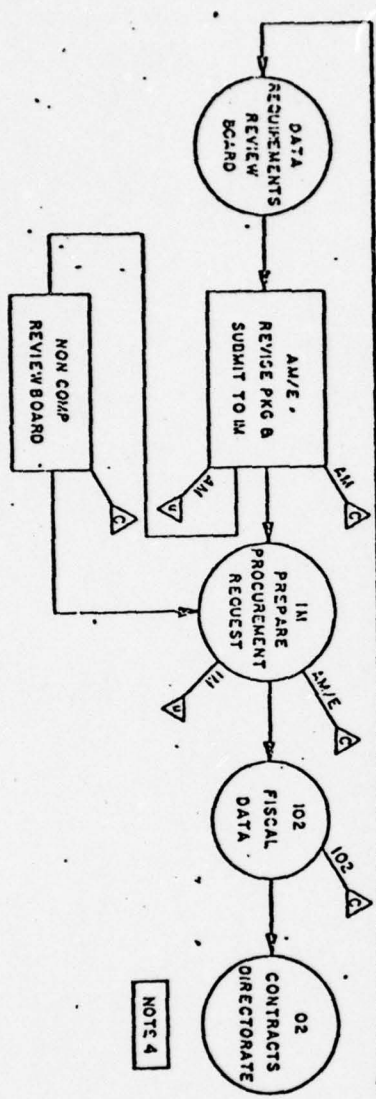
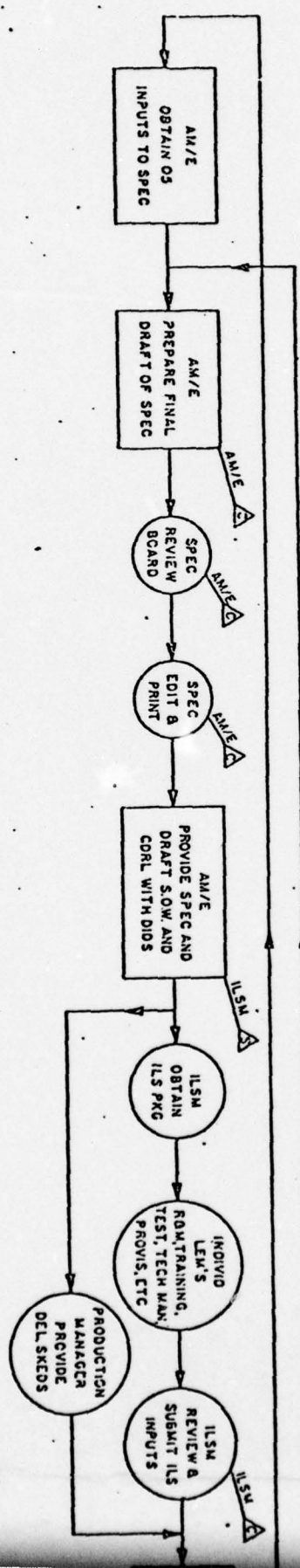

NOTE 4

- NOTES:
- 1 SEE NAVELX INST 4200 ID FOR EXCERPTING DETAILS. ONE DEFINITIONS AND RESPONSIBILITIES OF PERSONS INVOLVED. MINOR VARIANCES ALLOWED IF SUFFICIENT JUSTIFICATION COMPETENT AUTHORITY.
  - 2 THE OS PLANNED HALLESTONE SHEETS. IF NOT THE PD MUST AT THIS POINT IN TIME, THE AVE PREPARES THE APP FOR RE CONFORMANCE WITH 201 (IF AN APP IS REQUIRED) LAW ELEX OR 4 THIS IS THE "INITIATE" DATE OF THE I/O PLAN.
  - 3 REPORT START, REVISION, COMPLETION TO OS MIS.
  - 4 UPDATE RACC FILE

SUMMARY

NOTE 1

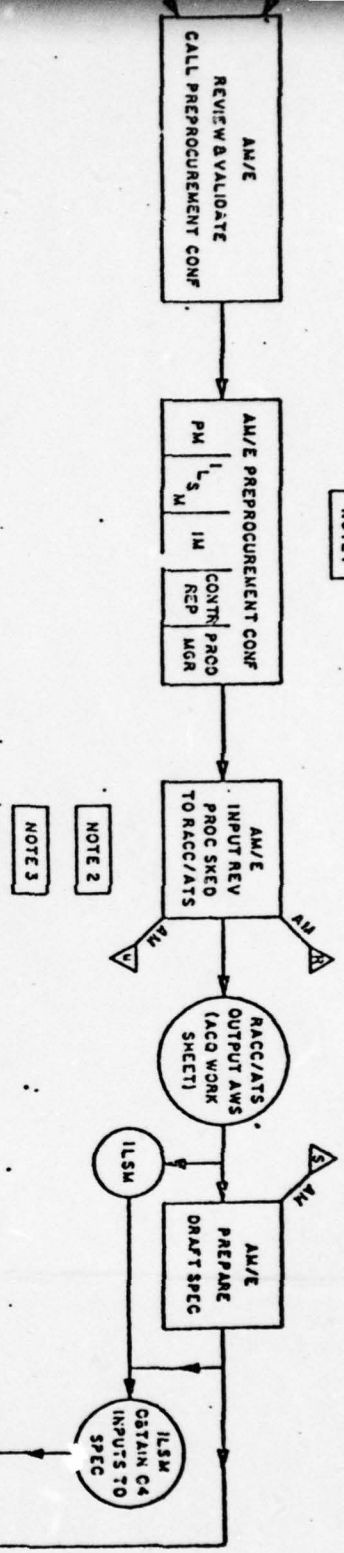

NOTE 2

NOTE 3

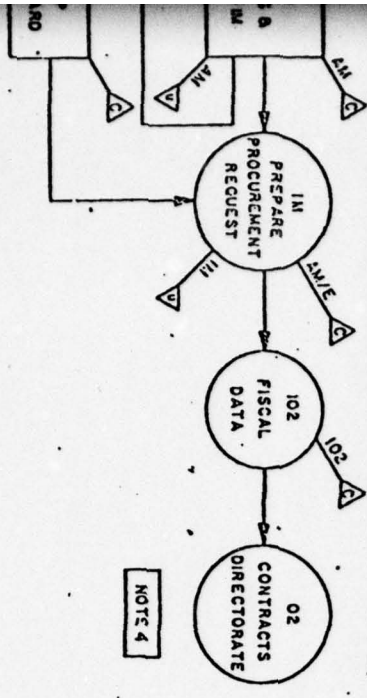
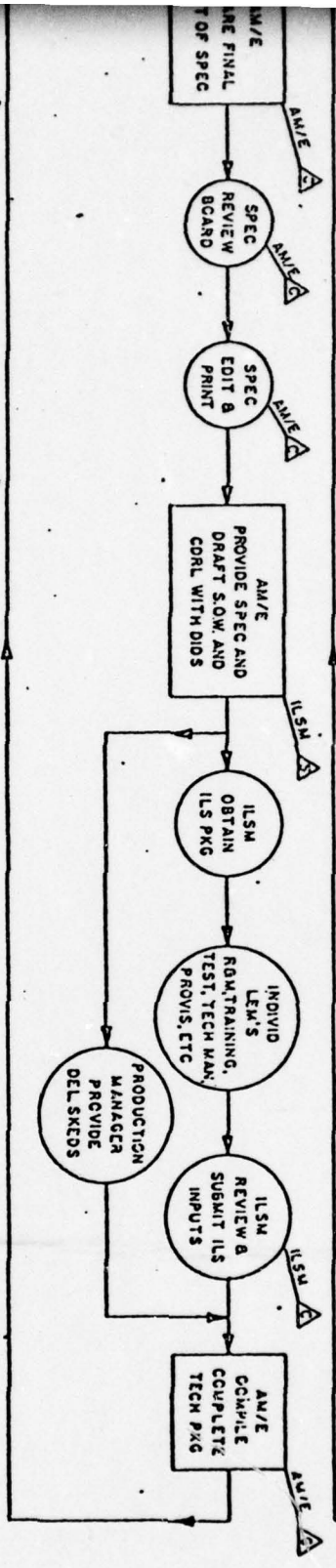

NOTE 4

NOTES:

1. SEE NAVLEX INST 4200 IO FOR EXERCUCATING DETAIL, 3. CHECK OFF SHEETS, DEFINITIONS AND RESPONSIBILITIES OF PERSONS INVOLVED, AS WELL AS THE MINOR VARIANCES ALLOWED IF SUFFICIENT JUSTIFICATION IS PROVIDED BY THE COMPETENT AUTHORITY.
2. THIS REV SKED MUST TRACK WITH THE ELEX INITIATION/OSLATION PLAN AND THE OS PLANNED MILESTONE SHEETS. IF NOT, THE PM MUST REPORT DELAYS TO OS/RC.
3. AT THIS POINT IN TIME, THE AM/E PREPARES THE APP FOR REVISION. THE RETURN CONFORMANCE WITH ZOI (IF AN APP IS REQUIRED) LAW ELEX INST 4200-61.
4. THIS IS THE "INITIATE" DATE OF THE I/O PLAN.

REPORT, START, REVISION, COMPLETION TO OS MIS.

UPDATE MACC FILE

Figure 3 C

2

the process lengthened, and costs skyrocketed. In reviewing the process, several inadequacies surfaced:

a. Documentation was passed from one amorphous code to another amorphous code, but no one had direct responsibility. Hence, if it were assigned to an individual (not known to the originating code), the documentation just remained in their "in-basket" until they were able to handle it. If they were out of the office on official travel or leave consistently, no one assumed the workload.

b. Follow-up control did not exist. In some instances, it was not prioritization of tasks which was the issue, but a matter of the "squeaking wheel getting the oil", insofar as accomplishment of work at hand.

c. NAVELEX was not obligating their resources in a timely manner. Regardless of the complexity of the process, this process was not initiated soon enough.

At the ZEM Retreat, a Task Force was established, with a goal of determining what actions might be taken to produce better quality procurement products' package, reduce overall processing time, and minimize the number of manhours spent in processing and solicitation review. Related to this issue, several sub-tasks were assigned to specific functional groups, as follows:

- a. Detail the existing process from requirement definition to contract award.
- b. Evaluate the 'value-added' by each review and 'chop' in the

- cycle.
- c. Examine the role of the review boards and the efficiency of their procedures.
  - d. Develop an improved acquisition process composed of minimum essentials.
  - e. Determine whether PR preparation should be centralized or de-centralized.
  - f. Investigate standardization of formats for PRs, SOWs, data items, and specifications.
  - g. Recommend a scheduling scheme for the process, including a follow-up system.
  - h. Determine the location and utilization of the centers of expertise in the various acquisition disciplines.
  - i. Recommend a program to provide intensified training for user personnel.

Generally, the studies were conducted in two parts...a review by cognizant personnel (including PME acquisition engineers) to surface any problems and recommendations, and subsequent meetings to make comments/recommendations based upon their review of background information relating to the sub-tasks.

All Task Force personnel were required to undertake and complete their studies within one month (August 1977). An overview summary of the project was deadlined for delivery to the Deputy Commander, NAVELEX on 1 September 1977.

Chapter IV

Evaluation of Proposed Procedure

On 3 October 1977, the new procedure was officially "turned on". ELEX Managers were informed that NAVELEX Instructions 4200.8C and 4200.10B would be re-written by 31 October 1977, to reflect the new methodology. Until that time, an interim instruction would describe the accelerated work-process flow. Further, it was pointed out that two acquisition procedures would be in effect -- the old and new-- until all procurements planned under the old procedure had been completed.

An OPN MIS printout was produced of all items in the OSD Budget, identified by nomenclature, for which NAVELEX buys are planned. These OPN Budget requirements, along with SCN, FMS, and other agency requirements will be screened against available RFI (Ready for Issue) assets, and /or Non-RFI assets. All computer-generated reservations and "buy" recommendations will be reviewed by the IM (Inventory Manager) to insure that the most urgent requirements are satisfied, first. Buy requirements will be consolidated and sorted by 1 November 1977. ELEX 05 will advise other agencies (Army, Air Force, FAA) of NAVELEX's proposed buys for FY 1979, and advance MIPR's will be requested for their requirements.

After proposed buy requirements have been furnished to cognizant Acquisition Managers, ELEX 504 will schedule Acquisition

Planning Conference (APC's). Included will be the Acquisition Manager, Requiring Manager, Integrated Logistics Support Manager, Inventory Manager, Procuring Contract Officer/Negotiator, Data Management Officer, and others who may be deemed to have an input to, or action on, the proposed procurement. This will be accomplished by sending a memo to each Division Director, advising of the time of the conference, place, equipment, and any other pertinent information. It will be the Division Director's Responsibility to insure that a specific individual (by name), who can appropriately represent his division's interests, is assigned to attend each APC. The participants at these conferences will undertake the following tasks, sequentially, and:

- (a) decide on the method of procurement, type of contract, basic format and scope of the Acquisition Package.
- (b) review the ASU (Approval for Service Use) Status and PP (Procurement Plan).
- (c) initiate start-work action on specification preparation or change, the SOW, and the D&F.
- (d) schedule the events and reviews that will be required for the procurement. All the items on the Acquisition Planning Conference (APC) will be addressed at the meeting.

Within two (2) days after the meeting, ELEX 504 will document the decisions reached by the Acquisition Team, and distribute a copy to each Team member.

Milestones to be monitored will be selected from the list

in Figure 4. The schedules for all procurements will be placed in the Requirements Accumulator/Acquisition Tracking System (RACC/ATS) and copies forwarded to cognizant AT members. ELEX 5041 will be responsible for all RACC/ATS inputs and updates, for the monitoring of all scheduled events and required actions and for producing an alert for the first milestones as well as missed milestone reports when any succeeding milestone is missed.

As an example, description of a model procurement follows: (see Fig. 5).

a. A draft specification will be completed by 22 January 1978, and forwarded to the ILS Manager. ILS requirements will be completed and passed to the Acquisition Manager (AM) by 22 February.

b. The AM will prepare the final specification and forward it to the Specification Review Board for approval, printing, and distribution. Further, Data Review Board approval will be obtained, with a possible final review at a later point in the acquisition cycle.

c. The Acquisition Manager will then assemble the Technical Package, forward copies to all Acquisition Team members for review and schedule a Reconciliation Conference. AT members will have 10 days to review the completed package to insure that those items agreed to in the Acquisition Procurement Conference (APC) have been adequately covered.

d. All Acquisition Team members will signify their concurrence by signing the completed Technical Package at the Reconciliation

APC DECISION PAPER

- 1. Equipment nomenclature-
- 2. Estimated quantity- Estimated hardware cost-
- 3. Earliest RDD (Required Delivery Date)-
- 4. Specification Status (Military spec., Contract spec., revisions required, etc.)-
- 5. SOW (Statement of Work) status-
- 6. ASU (Approval for Service Use) status--
- 7. Planned method of procurement-

<input type="checkbox"/> Formal advertising	<input type="checkbox"/> Competitive
<input type="checkbox"/> Two-step formal advertising	<input type="checkbox"/> Non-Competitive
<input type="checkbox"/> Negotiation	

- 8. Type of contract-
- 9. a. Radio Frequency Allocation required?  
b. If yes, date requested \_\_\_\_\_ or date granted \_\_\_\_\_
- 10. Security classification-
- 11. PP (Procurement Plan)- If a NAVELEX PP has been prepared, it should be revised to reflect APC schedule decisions.
- 12. Schedule Planned Date
  - A. Draft Spec. complete-
  - C. ILS Reqmts. complete-
  - D. DRB (Data Review Bd.) approval-
  - E. Final spec. approved by Spec. Rev. Bd.-
  - F. Final spec. printed
  - G. TP (Tech. Pkg.) circulated to AT members-
  - H. Reconciliation mtg.-
  - J. Final TP complete-
  - K. PR released by originator-
  - L. PR released by ELEX 102-
  - M. Solicitation mailed-
  - N. Contract awarded-

Figure 4

A. Draft Spec. complete (20-day alert)	
B. Not used (c thru N- outstanding MS report produced)	32 days
C. ILS Reqmts. complete	
D. Data approved by Data Rev. Board	
E. Final Spec. approved by Spec. Rev. Board	31 days
F. Final Spec. printed	
G. Tech. Pkg. circulated to AT members	
H. Reconciliation mtg. of AT	15 days
J. Final Tech. Pkg. complete	9 days
K. PR released to ELEX 102 by ELEX 504/PME	13 days
L. PR released to ELEX 02 by ELEX 102	2 days
M. Solicitation mailed	32 days
N. Contract awarded	122 days

TOTAL= 8 mo's. & 16 days from  
draft spec. comp. to  
contract award.

Figure 4 (cont'd)

Conference.

e. The Acquisition Manager will make directed/agreed upon changes to the Technical Package by 16 April and forward it to ELEX 504. Before preparing the Purchase Request (PR), the IM will screen assets for carcasses which may be available, or may become available, through program cancellations, stricken ships, restoration, changes to existing multi-year contracts, or contract quantities. PR quantities will be adjusted accordingly. If all requirements can be satisfied through any or all of the foregoing means, the planned procurement will be cancelled.

f. At this point, the Inventory Manager (IM) must identify all other customer requirements, i.e. MIPR's, requisitions, SCN, others to verify that funding is still planned to be available. He then obtains the delivery schedule, rate, and reporting requirements from the Production Management Branch, and prepares the PR. The PR will be prepared by 1 May and forwarded to ELEX 02, Contracts Directorate via ELEX 102 (Fiscal).

g. Allowing ELEX 260/270, (Contracts Purchasing), a 5-month leadtime will result in contract award by early October, when FY 1979 funds become available.

It is recognized that all NAVELEX procurements are not the same and cannot be placed in a mold. There are sufficient and compelling reasons why some procurements cannot be started in November and awarded October of the following year. Some



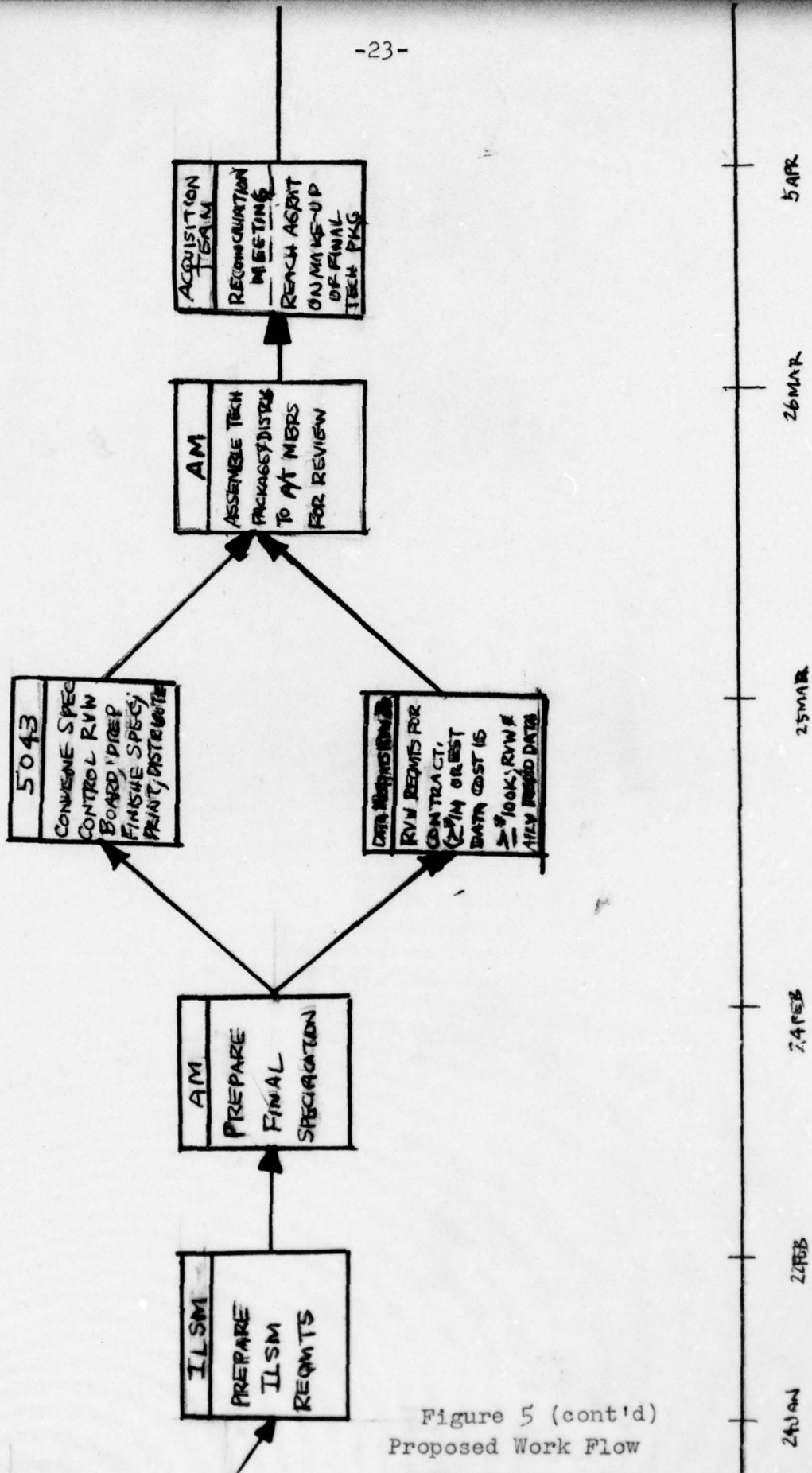
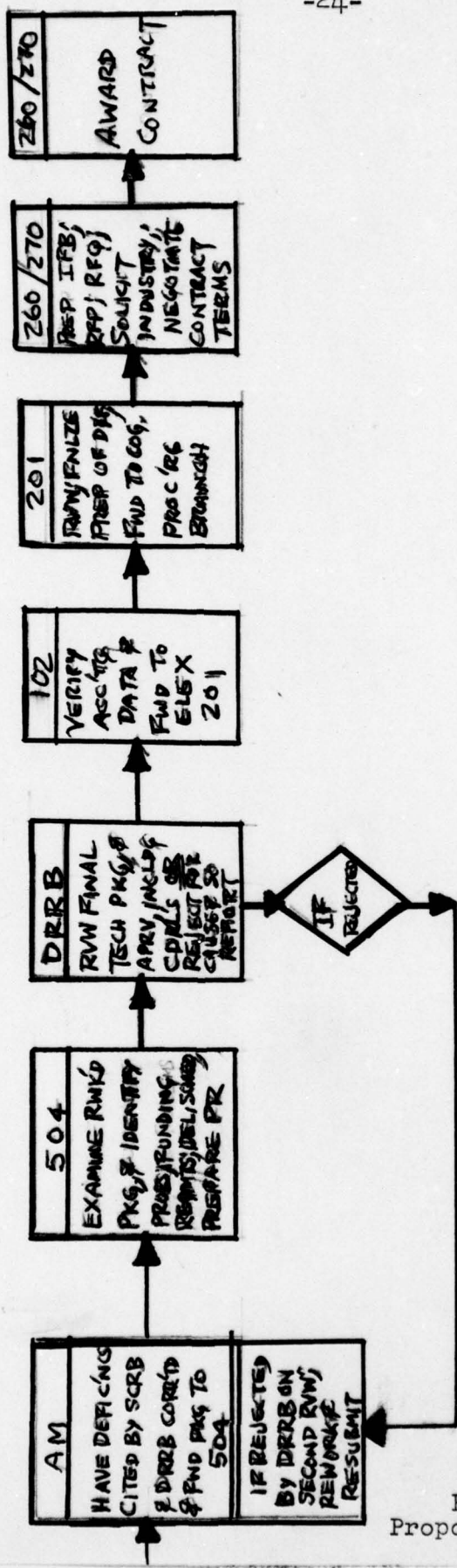

Figure 5 (cont'd)  
Proposed Work Flow



Timeline markers from left to right:

- 5 APR
- 6 APR
- 17 APR
- 21 APR
- 27 APR
- 28 APR
- 2 MAY
- 3 MAY
- 4 MAY
- 8 MAY
- 8 OCT

Figure 5  
Proposed Work  
Flow

processes in the foregoing procedures will take a longer or shorter time, on a given procurement, because of their peculiar requirements or problems. The time frames in these procurements and the parallel processing of some actions, can and should be adhered to, however, for most of the Command's hardware procurements.

Shortly before the implementation of the new procedure, ELEX 04 raised a point of issue concerning the new initiative. The issue raised was the point and time in the acquisition process that the Data Requirements Review Board (DRRB) should perform its chartered functions. This alternative was surfaced despite the fact that ELEX 04 was represented at every session of the Task Force study committee by one of more personnel and despite the committee's belief, at its final meeting, that reconciliation (albeit reluctantly) was obtained on all differences.

The minority opinion stated that Data Requirements Review Board's functions should be performed absolutely last in the acquisition process chain of events. A DOD Directive is cited as the authority which states that the DRRB should perform just prior to contract award or at least solicitation release, if one is to accord credence to the ELEX 04 interpretation.

The issue of the DRRB, and all boards, was considered and discussed at length in the Task Force analysis of the acquisition process. One of the specific subtasks was to analyze the functions of all boards involved in the process, and determine their ne--

cessity, including their "value added", to the acquisition process. If required, their proper interfaces and point and time of performance was ascertained. The following three Board reviews were considered: the NCRB (Non-Competitive Review Board) the Specification Control Review Board, and the Data Requirements Review Board. It was determined that, with respect to the Non-Competitive Review Board, ASPR requires only that such procurements in excess of \$10,000 be reviewed at a level higher than the contracting officer. This review could be performed by the Purchase Division Directors (ELEX 270/260). Hence, it was recommended that the NCRB be disestablished. A "to-be-renamed" Board would continue to review support-services procurements.

With regard to the Data Requirements Review Board and the Specification Control Review Board, the Task Force determined that both should continue, and that the performance of their respective functions should be done in parallel with other actions, instead of in series, after major completion of the acquisition package.

The acquisition flow process proposed in the report of the Task Force was believed by the committee members to be the optimum, considering all factors. When the minority, and dissenting opinion, surfaced three weeks after the proposal was sent to the Deputy Commander, it appeared that ELEX 04 had reconsidered what its representatives had agreed to, in sessions.

The majority opinion pointed out that the review conducted

by the DRRB is just one of many reviews of a procurement which should be properly conducted, considering it a co-equal with reviews of technical features (tailor specs to needs), total life cycle costs versus design-to-costs. The Task Force believed that all of these factors, including Data Requirements should be considered in totality by the Acquisition Team, and proper trade-offs considered, decided and documented. To separate the review of data requirements from an overall review in totality (total acquisition review) was not considered the optimum approach. It was believed that a piece-meal review would add additional time, in serial fashion, preclude review of the acquisition in a context of totality (technical and total-cost aspects), and would not improve the quality of the acquisition package, (which was one of the goals of the Task Force Committee).

The Task Force further pointed out that the ELEX O4 interpretation of the DOD Instruction concerning "final review" was indeed a narrow one, which precluded review of the acquisition in consideration of all its factors (requirements, technical and business). It would appear that ELEX O4 felt that the requirements for, and adjudication of data issues, took precedence and importance over all factors of the acquisition.

The Task Force committee did not feel that a standing committee, with an ad hoc charter having no responsibility for the outcome of the acquisition, or the downstream long-term effects of its decisions (life cycle costs and ILS) should

be in a superior position over the Acquisition Team who considered the total environment of the acquisition, and have worked on it since its conception. The latter would certainly be knowledgeable and responsible participants in the process.

The Task Force stated that, were this minority opinion to obtain, NAVELEX would remain in a posture of recycled paper and argument. The concept of checks and balances is considered workable, if not driven to excess, and the proposal itself was considered to contain adequate checks and balances.

This difference in opinion was then forwarded to the Deputy Commander NAVELEX. He resolved the issue by stating that the DRRB, a time-consuming review, should be considered earlier in the acquisition cycle, thus allowing sufficient time to make required corrections. This new placement is at the reconciliation meeting (Fig.5), which will permit resolution of any discrepancies early in the cycle.

Chapter V  
Evolutionary Changes

The environment of program management places an extraordinary premium on talent for leadership as distinguished from command-on-persuasion, as distinguished from direction. Finding ways to compress the acquisition cycle without increasing concurrency, or risks, are among the most difficult challenges for the future.

An increased emphasis on front-end planning, as evidenced in the new NAVELEX flow process will permit a more encompassing view toward optimizing the complete cycle. This will force a recognition of conflicts between subelements, and promote effective early tradeoffs. Secondly, policies and procedures will be applied, which are more consistent with commercial practices...e.g. design-to-cost, "hands-off" competition, warranties, and tailoring of specifications.

NAVELEX has stated that this new strategy will be fine-tuned during the coming year. When queried as to the possibility that this experiment "might not take", the opinion was proffered that the SYSCOM would never return to the <sup>old</sup> procedure, merely revise the new system until it worked.

One of the questions that concerned the author was how this system would be "sold" or communicated to the lower levels of the organization. And the answer appears to be when it

becomes a matter of policy, as implemented by new instructions, there will be no question about its acceptance. Yet, one of the more visible codes has already taken exception to the procedure.

Advocates of bold new strategies have not recognized that they must first "uncouple" the functions from the viselike grip of past strategies before they can expect an appropriate response at lower organizational levels. Long-time adherents to a particular method of performance will instinctively resist changes in the way they get things done. Several suggestions might prove effective:

1. Before implementing this strategy, management should make certain that a serious functional overload does not exist.
2. To avoid strategic shock waves, employees should be briefed on the new plan. In this instance, two processes will be running in parallel for a year or so...the old, cumbersome method, and the new, streamlined one.
3. Recognizing that problems might exist in these two systems, managers should establish a mechanism, in advance, for coping with such problems before they arise, and otherwise, personally monitoring their application.
4. The Task Force team, an ad hoc group, should not be disbanded until it has identified follow-through actions. There should be clearly-stated milestones by which the team can assure that the Command is changing to its new course.

5. Communication downward, not just upward, must exist. The Task Force Team has been preoccupied in communicating the new strategy to higher organizational levels. The more difficult task, easily slighted, is that of reaching managers and others at lower echelons. The latter hold the key to the successful implementation of the program. Furthermore, they need a deeper insight into proposed changes than managers at higher levels.

How does one bridge the gap between management's intent and the subordinates' understanding? Specialists have to be retrained and new work procedures documented. If one segment fails to move in concert with the others, the new procedure will be swept along on the old course. All functional areas must be coupled to the new plan, not just a few. One laggard, one half-hearted functional commitment may endanger the goals established for the Command as a whole. Lastly, integration has always been one of the primary elements of managerial work. It is unrealistic to promote a new plan as a technique for coping with a fast-changing environment, without taking into account how it affects the other major duties of organizing, integrating, and measuring.

NAVELEX expects a shake-down period of several months to fine-tune these new procedures. Around mid-November 1977, training sessions, and question and answer sessions will be held with supervisors to discuss and resolve any problems that may have arisen. In turn, supervisors will conduct training seminars for their organizational components. One of the larger problems that arises is the ability of these

that arises is the ability of these "linking pins",<sup>4</sup> to communicate the material accurately, and with the requisite and persuasive talents.

As an adjunct, a comprehensive NAVELEX Procurement Guide should be drafted, which describes the procurement cycle, with excerpts and/or references to ASPR paragraphs or NAVELEX Instructions.

During the course of review of the present system, it was found that 10 different offices within NAVELEX prepare PRs. With the exception of two PME's, the PR function will be centralized in one office. Like-wise, a long, searching look was taken at the Contracts Directorate which has a separate policy and planning branch to prepare all the PPs, JANs, and D&Fs for the Command. Consideration may be given to moving these staff positions to the respective purchase divisions, or program offices so that they might be a continuing part of the entire acquisition process.

---

<sup>4</sup>Likert, Rensis. The Human Organization, Its Management and Value. (New York: McGraw Hill, 1967), p. 160.

-33-

## Chapter VI

### Summary

After a detailed and broad-ranging view, the Task Force proposed actions to streamline the acquisition process in the areas of minimizing required processing and review, standardized formats for necessary paperwork, and improved training for user personnel. And yet the significant factor that emerged from this analysis is that NAVELEX was not obligating its budgeted resources in a timely manner.

Irrespective of the complexity of the process, the work flow process has consistently not been initiated soon enough. On continuing programs, NAVELEX has a sufficient level of confidence by October 1 of each year, as to the probable approved content of the second following year program. Likewise on new starts, NAVELEX should have a sufficient level of confidence by 1 December of each year as to the probable approved content of the second fiscal year program. A model procurement demonstrated that by initiating the acquisition process at these times (October and December each year), eight months later, when the dollars flowed from the approved budgets, the procurement actions (IFB's, RFP's) can be ready for issuance.

The second unique feature of the new acquisition process is the formation of a discrete Acquisition Team for each procurement. The functional codes (or PME's) will assign

the Acquisition Manager, who, together with his team, will drive the acquisition process. Several benefits to management are quite evident in the proposed system relative to the existing system. The most significant are:

1. The proposed system provides an integrated, time-phased structure for developing objectives, tasks and targets. The existing structure has less definition.

2. Responsibilities for developing and achieving objectives are well defined. All involved will know exactly what they are expected to accomplish.

3. The system will yield more accurate performance measurement and realistic control by providing meaningful and timely information to top management and feedback on performance to the Acquisition Team.

4. The system promotes participation in, and commitment to, the objectives. This will insure that the objectives are both significant and realistic.

It has been said that "between the great things that we cannot do, and the small things that we will not do, the danger is that we shall do nothing."<sup>5</sup> The creation of a revised internal procurement procedure cannot be classed as a major event in the history of NAVELEX, but it does demonstrate that the determination of the Task Group to recommend action, as a result of the Charlottesville conference, can clearly result in a step forward toward better management.

---

<sup>5</sup>Tashjian, Michael J. "An Appraisal of the Effectiveness of Centralized Contract Administration (Unpublished Thesis, George Washington University, 1970), p. 107.

Chapter VII

Additional Areas of Study

A quarterly follow-up of this proposed work flow process might be undertaken by NAVELEX. The initial months of operation will be uneven; nevertheless, the results can be compared with the benefits envisioned.

A further study might compare similar acquisition flows in counterpart SYSCOMS-NAVAIR and NAVSEA. And lastly, higher headquarters, NAVMAT, might be queried as to the value of these new procedures. This organization ultimately approves the SYSCOM end products.

BIBLIOGRAPHYBooks

- Bennis, Warren G. Changing Organizations. New York: McGraw Hill, Inc. 1966.
- Furst, Sidney and Sherman, Milton. The Strategy of Change for Business Success. New York: Clarkson N. Potter. 1969.
- Huse, Edgar F. and Bowditch, James L. Behavior in Organizations: A Systems Approach to Managing. Reading, Mass: Addison-Wesley Publishing Co. 1973.
- Kast, Fremont E. and Rosenzweig, James E. Organization and Management, A Systems Approach. New York: McGraw Hill, Inc. 1970.
- Likert, Rensis. The Human Organization: Its Management and Value. New York: McGraw Hill, Inc. 1967.
- Odiorne, George S. How Managers Make Things Happen. Englewood Cliffs, N. J: Prentice-Hall, Inc. 1961.

Periodicals

- Argyris, Chris. "Double Loop Learning In Organizations." Harvard Business Review, September-October 1977, pp. 115-125.
- Gansler, Jacques S. "Let's Change the Way the Pentagon Does Business." Harvard Business Review, May-June 1977, pp. 109-118.
- Gansler, Jacques S. "A New Dimension in the Acquisition Process". Defense Systems Management Review, Autumn 1977. pp. 6-12.
- George, William W. "Task Teams for Rapid Growth." Harvard Business Review, March-April 1977, pp. 80.
- Kotter, John P. "Power, Dependence and Effective Management." Harvard Business Review, July-August 1977, pp. 125-136.
- Lawrence, Paul R. and Lorsch, Jay W. "New Management Job: The Integrator." Harvard Business Review, November-December 1967, pp. 40-49.
- Pierre, Lt. Col. Russell, Jr. USA and Peppers, Jerome G. Jr. "Conflict in Organizations: Good or Bad?" Defense Management Journal, October 1977, pp. 47-53.

37  
Scott, Charles. "A Functional Planning/Control System for Procurement". Proceedings of the Fourth Annual Department of Defense Procurement Research Symposium (U. S. Air Force Academy, Colorado, 1975), p. 199.

MISCELLANEOUS

Bennett, John Joseph. "Department of Defense Systems Acquisition Management: Congressional Criticism and Concern." Unpublished Dissertation, George Washington University, May 1974.

Mankin, Richard Thurmond. "The Contracting Officer and The System Manager: An Analysis of Authorities and Responsibilities Within the Department of Defense." Unpublished MBA Thesis, The George Washington University, 1974.

Meiners, Arthur Charles. "Control of Major Changes to and Resultant Cost Growths in Weapon Systems Acquisition Contracts." Unpublished Dissertation, George Washington University, February 1974.

Rochon, Everette Charles. "The Role of The Contracting Officer in the Systems Procurement." Unpublished MBA Thesis, The George Washington University, 1974.

Tashjian, Michael J. "An Appraisal of the Effectiveness of Centralized Contract Administration." Unpublished MBA Thesis, The George Washington University, 1974.

SPEECHES AND ADDRESSES

Speech by Jacques S. Gansler, Deputy Assistant Secretary of Defense (Material Acquisition) on New Initiatives in Defense Systems' Acquisition to the National Contract Management Association, Washington, D. C. 21 July 1976.

IED  
78