

AD-A052 164

ARINC RESEARCH CORP ANNAPOLIS MD
DESTROYER ENGINEERED OPERATING CYCLE (DDEOC) SYSTEM MAINTENANCE--ETC(U)
OCT 76

F/G 19/7

N00024-76-C-4319

UNCLASSIFIED

1645-50-4-1550

NL

1 OF 2
ADA
052184



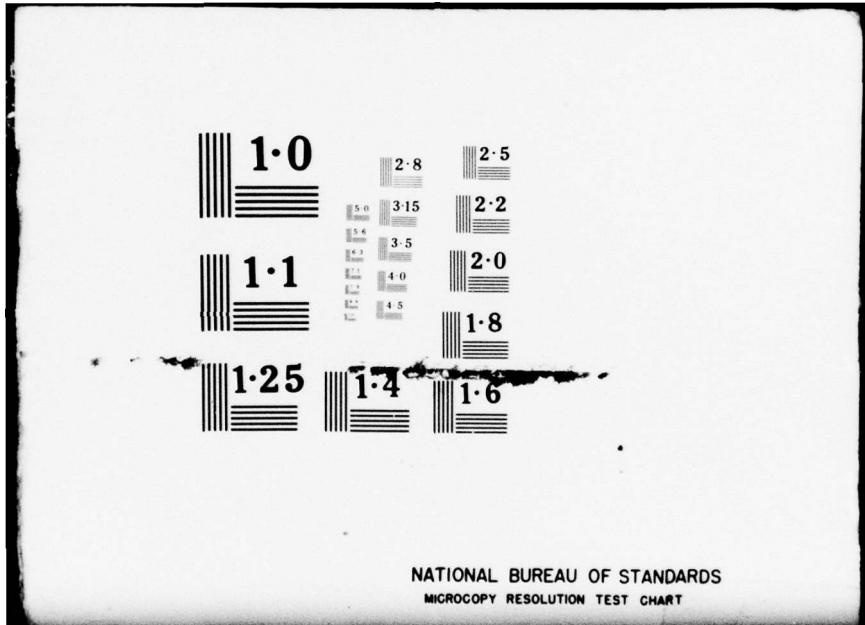

D

AD A 052164

DESTROYER ENGINEERED OPERATING CYCLE (DDEOC)

System Maintenance Analysis FF-1052 CLASS ASROC LAUNCHING GROUP

REVIEW OF EXPERIENCE

October 1976

Prepared for

Director, Escort and Cruiser
Ship Logistic Division
Naval Sea Systems Command

under Contract N00024-76-C-4319

AD NO. *[scribble]*
DDC FILE COPY

DDC
APR 4 1978
[signature]
F

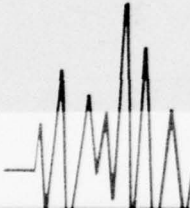

ARINC RESEARCH CORPORATION

This document has been approved
for public release and sale; its
distribution is unlimited.

1

6

DESTROYER ENGINEERED OPERATING CYCLE
(DDEOC)
SYSTEM MAINTENANCE ANALYSIS,
FF-1052 CLASS ASROC LAUNCHING GROUP,
REVIEW OF EXPERIENCE.

DDC
RECEIVED
APR 4 1978
RECEIVED
F

11 October 1976

12 122p.

Prepared for
Director, Escort and Cruiser
Ship Logistic Division
Naval Sea Systems Command
Washington, D.C.
under Contract N00024-76-C-4319

15

ARINC Research Corporation
a Subsidiary of Aeronautical Radio, Inc.
2551 Riva Road
Annapolis, Maryland 21401
Publication 1645-50-4-1550

14

This document has been approved
for public release and sale; its
distribution is unlimited.

400 247

LB

Copyright © 1976

ARINC Research Corporation

Prepared under Contract N00024-76-C-4319
which grants to the U.S. Government a
license to use any material in this pub-
lication for Government purposes.

FOREWORD

The System Maintenance Analysis Report for the ASROC Launching Group consists of a single volume, the Review of Experience. It presents a review of the maintenance experience for the Launching Group, an analysis of the problems encountered and anticipated, and recommendations for actions required to achieve the Launching Group DDEOC goal of improved material condition at an acceptable cost, while maintaining or increasing operational availability during an extended operating cycle.

ACCESSION for	
NTIS	White Section <input checked="" type="checkbox"/>
DDC	Buff Section <input type="checkbox"/>
UNANNOUNCED	<input type="checkbox"/>
JUSTIFICATION	
BY	
DISTRIBUTION/AVAILABILITY CODES	
Dist.	SPECIAL
A	

SUMMARY

1. INTRODUCTION

System Maintenance Analyses (SMAs) are being conducted on selected systems and subsystems of the FF-1052 Class ships as part of the Destroyer Engineered Operating Cycle (DDEOC) Program. This document, the Review of Experience (ROE), comprises the System Maintenance Analysis Report for the ASROC Launching Group.

2. PURPOSE AND APPROACH OF THE REVIEW OF EXPERIENCE

2.1 Purpose

The purpose of the Review of Experience is to present the results of an analysis of historical and anticipated problems that affect the operational performance and the maintenance program of the Mk 16 ASROC Launching Group. This report assesses the significance and consequences of the problems identified and makes recommendations to support an extended (54 month) operating cycle. Implementation of the recommendations should further the achievement of the DDEOC Program goal for the ASROC Launching Group, which is to effect an early improvement in the material condition of the system, at an acceptable cost, while maintaining or increasing its operational availability during the extended operating cycle.

2.2 Approach

The ASROC Launching Group SMA included an in-depth analysis of available maintenance data sources. The documented maintenance experience of the system was reviewed through analysis of Maintenance Data Collection Subsystem (MDCS) data, Casualty Reports (CASREPTs), DART Reports, and system overhaul records. Initial findings from these sources were correlated with Planned Maintenance Subsystem (PMS) requirements, system alterations, and system technical manuals to identify potential maintenance problems. Ship surveys and liaison with appropriate technical codes were conducted to validate identified problem areas, define undocumented maintenance problems, and determine the status of current and planned actions affecting

the Launching Group. All findings were evaluated, and conclusions were developed. Recommendations were then formulated to implement existing and newly defined corrective actions to minimize the occurrence of identified problems and their impact on the extended operating cycle.

3. RESULTS OF ANALYSIS

The ASROC Launching Group has historically been a high-maintenance-burden system, with the launcher ranking fourth on the FF-1052 Class Critical Equipments List*. The equipments included in this analysis accounted for 136 CASREPTs, 26,282 corrective maintenance man-hours, and \$399,499 in parts cost, as reported by the 46 FF-1052 Class ships over the five-year data period (these figures do not include overhaul expenditures).

Corrosion has been identified as the primary cause of the large amount of maintenance. High wave loading on the FF-1052 bow-mounted ASROC launcher and its spray-tight rather than water-tight design result in sea water intrusion, which aggravates corrosive action. In addition, the launcher suffers occasional gun-blast damage caused by the 5"/54 Gun Mount located directly forward of it.

The ASROC DART Program was established to identify and implement solutions to these problems. Major improvements resulting from DART Program activities involve anti-corrosion and reliability alterations, including a new launcher carriage shield, new guide-drive-pin assemblies, and modified guide snubbers.

4. CONCLUSIONS AND RECOMMENDATIONS

4.1 Conclusions

The principal conclusion of the analysis is that the ASROC Launching Group can be maintained at an acceptable level of reliability throughout the extended operating cycle provided the following actions are taken:

- Identified repairs and alterations necessary to bring Launching Group equipments up to current design standards are accomplished prior to or during BOH.
- ASROC Gunner's Mate manning levels are maintained at a level consistent with the proper performance of Launching Group maintenance requirements throughout the extended operating cycle.
- The effectiveness of the numerous alterations in preventing corrosive degradation of Launching Group equipments is periodically assessed throughout the operating cycle by means of a pre-SRA (18 month) inspection.

*FF-1052 Critical Equipments List Development, ARINC Research Corporation, 18 August 1975.

The completion of item 1 will require coordination between appropriate NAVSEA technical codes to effect integration of the ASROC Launching Group Major Overhaul Program with the Baseline Overhaul and Extended Operating Cycle constraints and to adopt standardized testing and inspection procedures and overhaul decision criteria.

Item 2 necessitates the determination of both the minimum acceptable ASROC Gunner's Mate manning level based on maintenance and operational requirements and the anticipated manning level during the extended operating cycle. If the anticipated level is insufficient to meet maintenance requirements, appropriate action must be taken to increase the man-hours available for maintenance by reducing collateral duties to ensure maximum utilization of available personnel in their primary function area or, if necessary, by assigning priorities to maintenance requirements to ensure that, as a minimum, the most critical actions are performed as specified.

Implementation of item 3 will provide a condition-assessment capability to monitor the effectiveness of the several major Launching Group Alterations, particularly in the area of corrosive degradation; to identify any unforeseen reliability or maintainability problems arising during the cycle; and to better plan the utilization of IMA and shipyard maintenance facilities at SRAs.

4.2 Recommendations

The principal recommendations of the analysis are summarized as follows:

- The following BOH repairs should be made:
 - Class "A" overhaul of Launcher Guides at NOS, Louisville
 - Class "A" overhaul or lesser shipyard repairs of Launcher Carriage to be determined by the POT&I
- Mandatory installation of alterations during BOH should include ORDALTS 7488, 7695, 8613, 8670, 8672, New Closure Devices, and New Power Drive Amplifiers (no numbers assigned).
- The Launching Group POT&I and Machinery Inspections should be combined to eliminate redundancy and provide more accurate and consistent definition of overhaul requirements.
- ASROC Gunner's Mate manning should be reviewed and necessary action taken to ensure the performance of Launching Group Planned Maintenance Requirements.
- A Pre-SRA inspection should be developed and implemented (1) to monitor the effectiveness of numerous major Launching Group alterations; (2) to monitor the corrosion status of Launching Group equipments; and (3) to better plan the utilization of IMA and shipyard maintenance facilities during the SRAs.

- The carriage heating and cooling hoses should be replaced during BOH, and the use of noncorrosive materials in hose construction should be investigated.
- Four procedural and scheduling changes should be made to the current PMS resulting in a net reduction in hard-time Launching Group PMS of approximately 392 man-hours per ship per year.
- Three ILS improvements should be made to improve Launching Group maintainability.

CONTENTS

	<u>Page</u>
FOREWORD	iii
SUMMARY	v
CHAPTER ONE: INTRODUCTION	1
1.1 Purpose	1
1.2 Launching Group Description and Boundaries	1
1.3 Launching Group Configurations	2
1.4 Report Format	3
CHAPTER TWO: ANALYSIS APPROACH	5
2.1 General Approach	5
2.2 Methodology	5
CHAPTER THREE: LAUNCHING GROUP ANALYSES AND PROBLEM IDENTIFICATION	7
3.1 Launcher Stand Mk 107, Mod 2, APL 005020012	7
3.2 Guide, Mk 7, Mods 1 and 2, APL 005020021	9
3.2.1 Thermometers, P/N 2245899	9
3.2.2 Snubbers, Bottom, P/Ns 1807540 and 1807541	10
3.2.3 Launching Rail Cylinder, P/N 2319708	12
3.2.4 Solenoid Valve, P/N 2319704	12
3.2.5 Thermostatic Switch, P/N 1676917, and Temperature-Sensing Device, P/N 1676905	13
3.2.6 Aft Blast Door, P/N 1815712, and Quick Disconnects, P/Ns 1788524 Pc. 3 and 1788376	13
3.2.7 Access Door, Oblong, P/N 1815516; Round, P/N 1807229	14
3.2.8 Safe-Fire Handle, P/N 1656707	14
3.2.9 Cover, Flexible, P/N 1806060	15
3.2.10 Rod Assembly, P/N 1656607	15
3.2.11 Guide Improvements and Alterations	15

CONTENTS (continued)

	<u>Page</u>
3.3 Launcher Carriage, Mk 7, Mods 2 and 3, APL 005020017 . . .	16
3.3.1 Guide Drive Pin, P/N 1676875, and Associated Parts, P/Ns 1807288, 1815565, 1221180-29, and 1253742 Pc. 1	17
3.3.2 Hydraulic Filter and Element, P/Ns 1284137 and 1778749, Rev. H	17
3.3.3 Air Motors, P/Ns 1655765 and 1656351	19
3.3.4 Air Lubricator, P/Ns 1807384 and 1807383	19
3.3.5 Heating/Cooling Hoses, P/Ns MS 28741-16-2030 and and MS 28741-16-2300	20
3.3.6 Firing Interrupter Cable Housings and Couplings, P/Ns 1787748/1787769 and	20
3.3.7 Missile Select Relay Rack and Rail Select Relay Rack -- Component Designation: 2A6 and 2A7	21
3.3.8 Switch, P/N 1788141	21
3.3.9 Carriage Improvements and Alterations	21
3.4 Launcher Captain's Control Panel (LCCP), Mk 199, Mods 3, 4, and 5, APL 005020013	23
3.4.1 Power Drive Amplifiers, P/N 1877413	23
3.4.2 P-1 Plug, P/N 1788210	23
3.5 Power Drives, Elevation Mk 62, Mods 2 and 3, and Train Mk 61, Mods 2 and 3, APL 005020015	24
3.5.1 Pressure Switch, P/N 1778695	24
3.5.2 Filter Elements, P/N 1778749, Rev. H	24
3.6 Simulator, Mk 6, Mod 2, APL 005020014	24
3.7 Test Set, Electrical System Missile, Mk 363, Mods 1 and 3, APL 005020022	24
3.8 Dummy Director, Mk 6, Mod 1, APL 006020524	25

CONTENTS (continued)

	<u>Page</u>
3.9 Major Restorative Maintenance for ASROC Launching Group .	25
3.9.1 Maintenance Trends	25
3.9.2 Major Overhaul Program for ASROC Launcher	26
3.9.3 Pre-Overhaul Tests and Inspections (POT&I)	29
3.10 ASROC Gunner's Mate (GMT-0891) Manning and Relative PMS Burden	29
CHAPTER FOUR: CONCLUSIONS AND RECOMMENDATIONS	33
4.1 Overview	33
4.2 Conclusions	33
4.3 Recommendations	34
4.3.1 Depot Improvements: Pre-Overhaul Inspection	35
4.3.2 BOH Repairs and Alterations	36
4.3.3 R&M Improvements	39
4.3.4 IMA Improvements	41
4.3.5 ILS Improvements	43
4.3.6 PMS Changes	47
REFERENCES AND SOURCES OF INFORMATION	49
APPENDIX A: DDEOC ACTION TABLE	A-1
APPENDIX B: MIP AND MRC COMPARISON	B-1
APPENDIX C: PART-REPLACEMENT DATA	C-1
APPENDIX D: CASREPT SUMMARY	D-1
APPENDIX E: LAUNCHING GROUP ORDALTS	E-1
APPENDIX F: MACHINERY AND INSPECTIONS AND MAJOR OVERHAULS	F-1
APPENDIX G: COMPUTATION OF ASROC GMT (0891) PMS MAN-HOUR BURDEN .	G-1

CHAPTER ONE

INTRODUCTION

1.1 PURPOSE

The purpose of this report is to present the results of an analysis of historical and anticipated problems affecting the ASROC Launching Group, Mk 16, as installed on the FF-1052 Class (hulls FF-1052 through 1097, inclusive). The report assesses the significance of the problems as they relate to the extended operating cycle and recommends corrective or preventive actions in support of the DDEOC Program goals.

1.2 LAUNCHING GROUP DESCRIPTION AND BOUNDARIES

The ASROC Launching Group functions operationally to stow and launch rocket-thrown torpedoes or rocket-thrown depth charges, thus providing the FF-1052 Class ships a stand-off attack capability for Anti-Submarine Warfare. Figure 1-1 is a block diagram of the Launching Group equipments analyzed in this document. Equipments are further described in Chapter Three.

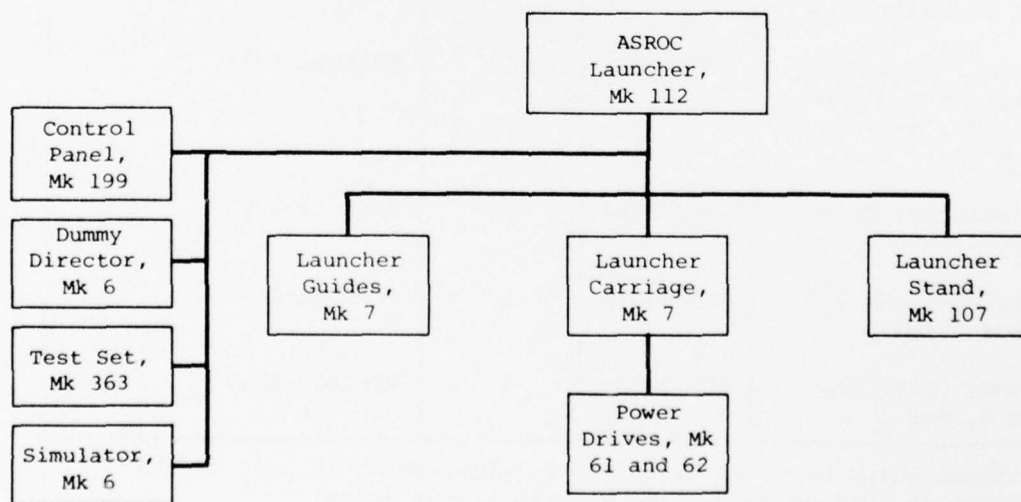

Figure 1-1. ANALYSIS BOUNDARIES: ASROC LAUNCHING GROUP, MK 16, MODS 5 AND 6

1.3 LAUNCHING GROUP CONFIGURATION

Table 1-1 delineates the major Launching Group equipments by nomenclature and APL number. The quantity of equipments per ship and applicable hulls are also identified.

Table 1-1. ASROC LAUNCHING GROUP CONFIGURATION, FF-1052 CLASS			
Equipment	APL	Quantity per Ship	Ships
Stand, Mk 107, Mod 2	005020012	1	FF-1052-1097
Guide, Mk 7, Mods 1 and 2	005020021	4	FF-1052-1055, FF-1057-1067, FF-1069-1071, FF-1073-1074, FF-1076-1077, FF-1080-1097
Guide, Mk 7, Mods 1 and 2	005020021	3	FF-1056, 1068, 1072, 1075, 1078, 1079*
Carriage, Mk 7, Mods 2, 3, 4	005020017	1	FF-1052-1097
Drive, Power, Elevation, Mk 62, Mods 2, 3; Train, Mk 61, Mods 2, 3	005020015	2**	FF-1052-1097
Panel, Launcher, Captain's Control, Mk 199, Mods 3, 4, and 5	005020013	1	FF-1052-1097
Simulator, Mk 6, Mod 2	005020014	1	FF-1052-1097
Test Set, Mk 363, Mods 1 and 3	005020022	1	FF-1052-1097
Dummy Director, Mk 6, Mod 1	006020524	1	FF-1052-1097
<p>*These ships have one Mk 13 Mod 0 Guide, which is part of the Interim Surface-to-Surface Missile System (ISSM). **APL 005020015 includes both train and elevation power drives.</p>			

1.4 REPORT FORMAT

This report consists of four chapters and seven appendixes. Chapter One presents introductory material and a description of the Launching Group, including configuration and analysis boundaries. The analysis approach and methodology are discussed in Chapter Two, and problem identification and analysis in Chapter Three. Conclusions and recommendations are presented in Chapter Four. Appendixes A and B contain tabulations of Action Requirements and MRC Comparisons, respectively. The remaining appendixes present supporting data and information.

CHAPTER TWO

ANALYSIS APPROACH

2.1 GENERAL APPROACH

The ASROC Launching Group System Maintenance Analysis (SMA) included an in-depth examination of all available maintenance data sources, with initial emphasis on Maintenance Data Collection Subsystem (MDCS) data. The Bibliography provides a complete listing of data sources used.

2.2 METHODOLOGY

Equipment Identification Codes (EICs) and Allowance Parts Lists (APLs) applicable to the Launching Group were identified, and a listing containing all labor and part records reported against those EICs and APLs was prepared (from the five-year MDCS data base). A summary of APLs was produced and obvious reporting errors were corrected. The APLs were then ranked by reported maintenance-resource expenditure, i.e., labor man-hours and parts cost. The purpose of this ranking was to focus attention on those equipments which have historically required the greatest expenditure of maintenance resources.

A computer tabulation of frequently used parts reported against these equipments was developed by means of a computer screening program that selected all parts that had been used by more than 10 percent of the ships. These were further screened to eliminate parts whose unit cost was less than \$10 and had been replaced on fewer than ten ships. These part-replacement data, tabulated in Appendix C, were used for the initial identification of potential problems within the Launching Group equipments.

CASREPT narratives covering the period 1 January 1970 through 31 December 1974 were reviewed, and summaries were formulated as presented in Appendix D. Correlations between CASREPTs and data on frequently used parts were identified for further evaluation.

ASROC Launching Group technical manuals and Illustrated Parts Break-downs (IPBs) were reviewed to verify the function and failure effect of significant parts. Ordnance Alterations (ORDALTS) applicable to the ASROC

Launching Group were identified via the Ship Alteration Management Information System (SAMIS) and Master Ordnance Improvement Plan (OIP). Appendix E tabulates these ORDALTS.

Planned Maintenance Subsystem (PMS) Maintenance Index Pages (MIPs) and Maintenance Requirement Cards (MRCs) were identified and reviewed, with special attention to requirements associated with frequently used parts and CASREPTs.

Ship surveys were conducted and technical codes were visited to validate initial conclusions and to identify undocumented maintenance problems.

DART Program quarterly reports applicable to the ASROC Launcher were reviewed, and further liaison with cognizant Navy technical codes was accomplished to clarify current actions affecting the Launching Group.

Launching Group major restorative maintenance requirements were identified by reviewing past FF-1052 Class Ship Alteration Repair Package (SARP) and Overhaul Departure Reports; examining the ASROC Launching Group Overhaul Manuals; and analyzing the Class "A" Major Overhaul Program inspections, procedures, and results. In view of the established program for Class "A" Major Overhauls and to ensure clarity and continuity, Launching Group restorative maintenance is discussed as a separate topic in Chapter Three. To further support the major restorative maintenance analysis and to determine if any unusual or significant maintenance trends should be expected during the longer operating cycle, MDCS data for the ten FF-1052 Class ships that had experienced the longest operating cycles (four to five years) as of 31 December 1974 were analyzed separately.

This analytical sequence sought to gather and correlate sufficient data to develop a composite of the historical maintenance problems within the ASROC Launching Group as they affect the DDEOC Operating Cycle and to relate the improvements (being implemented via DART and other ORDALTs) to these problems to determine maintenance requirements and highlight unresolved problem areas.

CHAPTER THREE

LAUNCHING GROUP ANALYSES AND PROBLEM IDENTIFICATION

This chapter presents the results of an analysis of the Launching Group equipments and correlates parts replacements, CASREPTs, ship survey findings, and other data to identify problems having DDEOC impact. The historical corrective maintenance burdens of these equipments are presented in Table 3-1. Discussions of Launching Group restorative maintenance requirements in relation to long-term maintenance trends and established programs are presented separately, as are comments regarding ASROC Gunner's Mate manning. The analyses performed in this chapter are the foundation for the conclusions and recommendations presented in Chapter Four.

3.1 LAUNCHER STAND MK 107, MOD 2, APL 005020012

The stand supports the launcher on bearings that permit rotation in train. Major components of the stand are:

- Training Circle and Mount Bearing Subassembly
- Bearings and Roller Paths
- Stationary Mounting Ring
- Lower Base Ring
- Heating Elements
- Cable and Loose Loop Support
- Stand Junction Box

Analysis of the launcher stand revealed minimal problems. Reported MDCS data reflected a low maintenance-burden ranking, with averages of 1.3 ship corrective maintenance man-hours per ship operating year (SOY), 0.5 IMA maintenance man-hours per SOY, and \$66 in parts expenditure per SOY. In addition, no CASREPTs were reported against this equipment. Review of PMS associated with the launcher stand indicated that the current maintenance requirements for the launcher stand are adequate for use throughout the extended operating cycle.

Table 3-1. MDCS CORRECTIVE MAINTENANCE BURDEN SUMMARY FOR LAUNCHING GROUP EQUIPMENTS

Equipment	APL	Ship Man-Hours		IMA Man-Hours		Parts Dollar Expenditures	
		Total*	Per SOY**	Total*	Per SOY**	Total*	Per SOY**
Guide	005020021	6163	48.9	4331	34.4	182703	1450
Carriage	005020017	8307	65.9	2979	23.6	92794	736
Panel, Mk 199	005020013	1548	12.3	231	1.8	45393	360
Power Drives	005020015	1339	10.6	186	1.5	29465	234
363 Test Set	005020022	197	1.6	195	1.5	8495	67
Stand	005020012	170	1.3	57	0.5	8253	66
Simulator	005020014	296	2.3	40	0.3	3313	26
Dummy Director	006020524	69	0.5	175	1.4	29083	231

*Total for data period January 1970 through December 1974.

**Total per Ship Operating Year.

Note: Total ship operating years are derived as follows:

$$\begin{aligned} \text{FF-1052 Class Ship Operating Years} &= \frac{\text{Total Ship Operating Months}}{12} \\ &= \frac{1511.6}{12} \approx 126 \end{aligned}$$

where

Ship Operating Month: any month after commissioning or 1 January 1970 (whichever is the later date) and before 1 January 1975, excluding time spent in major maintenance availabilities (Fitting Out, Post-Shakedown Availability, and ROH).

3.2 GUIDE, MK 7, MODS 1 AND 2, APL 005020021

The four launcher guides function to stow and launch the rocket-thrown torpedoes and depth charges. (The six ISSM-modified launchers in this Class contain three Mk 7 ASROC guides and one Mk 13 ISSM guide; see Table 1-1). The guide consists of two cells, each containing launching rails, side and bottom snubbers, restraining latches, hydraulic and pneumatic actuating and controlling equipment, forward doors, an aft closure, and access doors.

As shown in Table 3-1, the guides represented a high maintenance burden, ranking first in parts expenditures (\$1450 average per SOY) and second in total corrective maintenance man-hours (48.9 Ship Man-Hours and 34.4 IMA Man-Hours average per SOY). In addition, 37 CASREPTs (representing 27 percent of the Launching Group totals) directly related to the guides were identified (Appendix D).

On the basis of the results of ship surveys, liaison with cognizant technical codes, and maintenance documentation, the principal factor causing the guides' high maintenance level is considered to be corrosion due to wave loading and sea spray. This problem manifests itself in mechanical failures, electrical failures, structural failures, and related high part-replacement rates. The following sections discuss specific component maintenance problems.

3.2.1 Thermometers, P/N 2245899

One thermometer is installed on the aft end of each guide (upper cell) to allow inspection of temperature conditions within the guide. The thermometers are monitored hourly in accordance with PMS MRC J-16, D-1, and the temperature readings are recorded in a log. This monitoring procedure serves as a backup for the automatic high/low-temperature-sensing alarm system installed in the guides and, as such, is critical to the safety of the weapons within the launcher. The thermometer was reported replaced a total of 140 times on 27 FF-1052 ships (Appendix C). The primary reasons for replacement were corrosion of the setting dial and thermometer face due to exposure to the environment and breakage. Ship surveys revealed that the Ship's Force has difficulty procuring these thermometers through the normal supply channels, a factor that has been compounded by receipt of the wrong type of thermometer by the ship. In light of these problems, ship personnel considered the on-board sparing level (1 per ship) as insufficient**. However, comments from the Naval Underwater Systems Center (NUSC), Newport indicate that a review of logistics support of that item has been accomplished and no change in sparing level is required. The historical replacement rate of 1.1 per Ship Operating Year should allow sufficient time for resupply of the on-board spare prior to subsequent thermometer failure, and no extended operating cycle problems are anticipated.

3.2.2 Snubbers, Bottom, P/Ns 1807540 and 1807541

The most troublesome guide components are the two bottom snubbers. They provide grasping support for the ASROC missile and, together with the side snubbers, prevent radial movement of the missile within the cell. Pneumatic pressure extends and retracts the snubbers via a center-line piston. When extended, the snubbers are held in place by a hydraulic pressure lock on the two side-guide pins (pistons).

Eighteen (49 percent) of the 37 guide CASREPTs* were attributed to the bottom snubbers. The summary of frequently used parts for the guide revealed that the entire bottom aft snubber was replaced 26 times by 7 ships at a cost of \$2280 per snubber, and the bottom forward snubber assembly 18 times by 3 ships at \$2540 per replacement. Several snubber parts have also shown high usage. For ease of reference, an annotated reprint from the ASROC IPB is included as Figure 3-1 to illustrate these parts.

The most common failure mode associated with the snubbers is the inability to fully extend or retract them due to binding between the hydraulic pistons (No. 36 on Figure 3-1) and sleeves (No. 47 on Figure 3-1). When the cell is loaded and the snubbers extended, the pistons are also extended out of the sleeve. In this position they are exposed to the corrosive effects of salt air and sea water entering the cell via the non-watertight cell doors. The piston on the aft snubber was reported replaced 98 times by 16 ships; the forward piston 36 times on 13 ships; the sleeve (which is common to forward and aft snubbers) 110 times by 21 ships; and the associated packing, wipers, and washers many times on several ships. Fleet interviews confirmed this failure mode, as did discussions with NAVSEA technical personnel, who also reported some problems with piston manufacturing quality assurance. (Omission of one wiper was a quality assurance problem.) Compounding these problems is the inaccessibility to the snubbers for corrective maintenance when a cell is loaded.

The bottom snubber Extended/Retracted Switch, P/N 1253742 Pc. 1, was reported replaced 14 times on 9 FF-1052 ships. Corrosion again was indicated by the Ship's Force and the MDCS narratives as the recurring reason for replacement. The switch is spared on board, and its replacement should decrease with the installation of guide anti-corrosion improvements. No EOC-related problems are anticipated.

The sequence of operations on one snubber PMS, MRC J-16 M-7, calls for inspecting and verifying proper snubber operation prior to checking the hydraulic fluid level and accumulator nitrogen pressure. Since snubber operation is partially dependent on a properly filled hydraulic system and charged accumulator, it is functionally more correct to verify the hydraulic and nitrogen levels prior to checking for proper snubber operation.

*Appendix D.

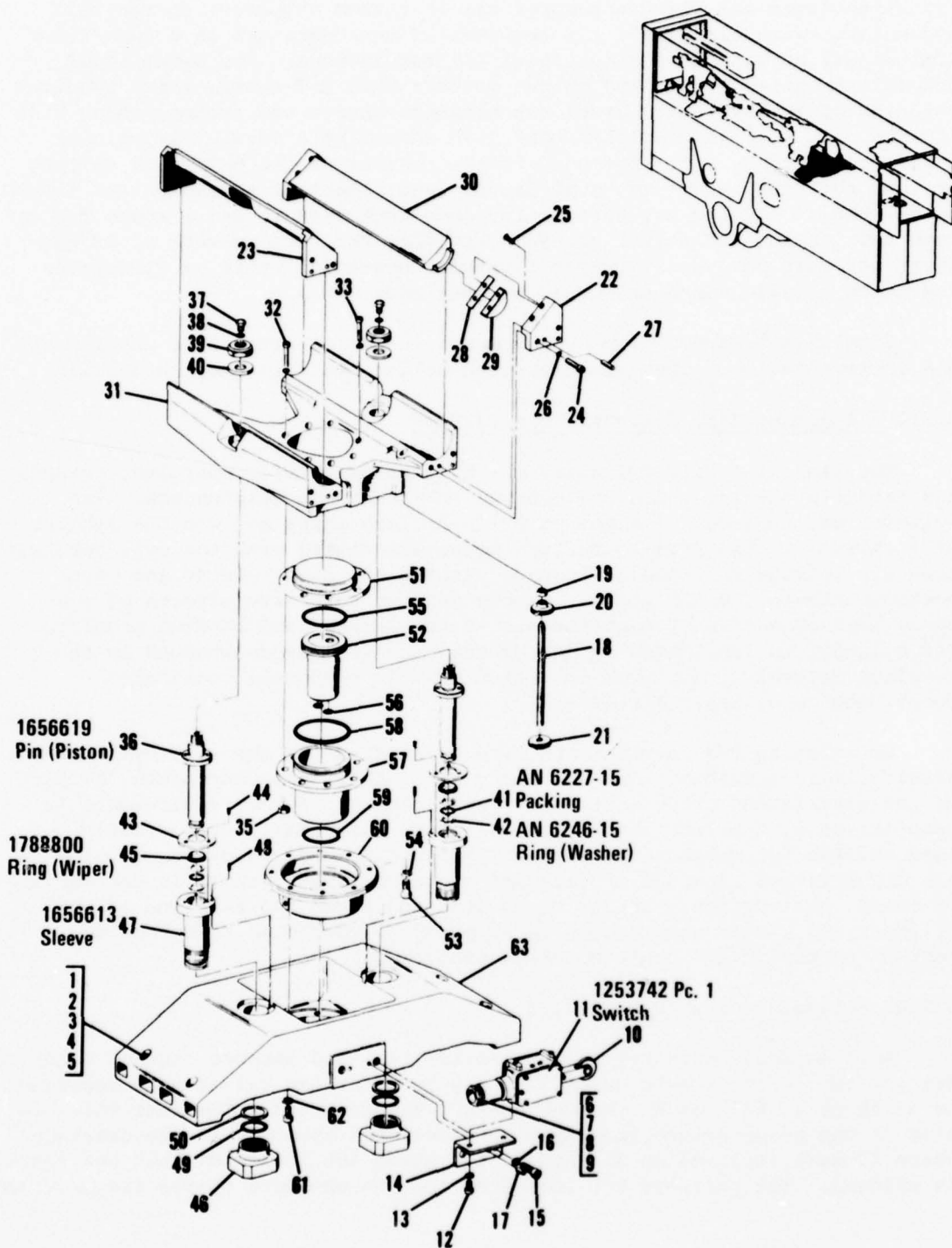

Figure 3-1. SNUBBER ASSEMBLY, BOTTOM FORWARD, P/N 1807541

Another PMS action for the snubbers is MRC J-16 S-4R -- "Replenish hydraulic fluid and bleed entrapped air in bottom snubbers; charge cell accumulator with nitrogen". It requires 14 man-hours and is a hard-time/semi-annual as well as a situational (R) requirement. Its situational accomplishment is predicated on the monthly J-16 M-7 check, which requires checking of the hydraulic level and nitrogen charge and accomplishing S-4R if necessary. It is concluded that S-4R should be a purely situational requirement, to be performed only if the results of the M-7 check warrant it, and that the hard-time, semi-annual requirement is redundant and should be deleted. Changing its periodicity code from S-4R to R-() would facilitate this action and reduce current hard-time PMS requirements by 28 man-hours per ship per year. Over a five-year operating cycle, a Class-wide reduction of 6440 man-hours could be realized.

Significant snubber improvements are in various stages of development and implementation. They are discussed collectively in Section 3.2.11.

3.2.3 Launching Rail Cylinder, P/N 2319708

The Launching Rail Cylinder, which is pneumatically operated, extends and retracts the launching rail during operation and maintenance. The cylinder was replaced 13 times on FF-1052 Class ships and was the subject of 2 CASREPTs. The primary failure modes associated with the cylinder have been air leakage and binding in the cylinder and rail. Water and other contaminants in the 300-psi air supply and the corrosive effects of sea spray have been primary contributors to the leakage and binding problems. The cylinder is lubricated by one of the air lubricators mounted in the carriage assembly. Improper operation of this component could also contribute to cylinder problems.

No existing PMS requirements were identified for the rail cylinder itself; it is routinely cleaned, along with other cell components, as part of the post-firing procedures. The establishment of PMS requirements is complicated by the location of the cylinder, which makes it virtually inaccessible for maintenance when the cell is loaded. However, in view of the CASREPTs and reported replacement of the cylinder, which is not carried on board, a situational action to monitor and clean the exterior of the cylinder and piston when a cell is unloaded is warranted to detect and correct corrosion and other material problems.

3.2.4 Solenoid Valve, P/N 2319704

Four solenoid-operated valves provide rail and snubber control functions for the two cells in each guide. Twenty-two of these valves were replaced on 13 ships at \$257 each, and one CASREPT was reported. The same valve is used in the guide-drive-pin/elevation-stow-latch assembly in the carriage, where 17 were replaced on 11 ships. The guide APL indicates that one spare is allowed. The carriage APL indicates that no on-board spares are provided.

The two primary reasons for replacing the valves have been leakage and failure of the solenoids to properly actuate the valve mechanism. The combined historical replacements of the guide and carriage valves yield a replacement rate of 0.23 per Ship Operating Year, indicating that current on-board sparing is sufficient. No recurrent problems are anticipated during the extended operating cycle.

3.2.5 Thermostatic Switch, P/N 1676917, and Temperature-Sensing Device, P/N 1676905

One thermostatic switch and one temperature-sensing device are installed in each cell. Their purpose is to detect high and low temperature levels within the cells and activate the high/low-temperature alarms. The thermostatic switch was reported replaced 71 times on 17 FF-1052 ships at \$42.78 per replacement. Replacement is normally accomplished because of an unsatisfactory resistance reading during PMS test (MRC J-16 W-8) or because of failure of the calibration PMS requirement, MRC J-16 A-9.

APL data indicate that the thermostatic switch is not spared on board. The temperature-sensing device is not listed on the APL under either the alternate P/N 1807582 or the new P/N 1676905.

During the ship surveys, Fleet personnel reported that the new and alternate switch/device combinations will not fit the same mountings.

A review of the logistic support of the switch and sensing device is considered necessary to ensure that appropriate parts are available under the proper part numbers. On the basis of the missile-safety aspects associated with the thermostatic switch and the number of reported replacements, the provision of one on-board spare is also considered justified.

3.2.6 Aft Blast Door, P/N 1815712, and Quick Disconnects, P/Ns 1788524 Pc. 3 and 1788376

The aft blast door is the frame portion of the aft closure assembly. One is attached to each cell by two permanently mounted hangers and 24 quick-disconnect stud and ring assemblies. MDCS data indicate 14 door replacements on 88 ships, 7108 stud replacements on 36 ships, and 4877 ring replacements on 29 ships. Corrosion was identified as the principal reason for replacement of these parts.

Integrity of the aft blast door and quick disconnects is paramount to preventing sea water from entering the cells. OP 2385, Vol. 1, Revision 3, states: "Whenever the aft closure is loosened or removed, make certain to retighten all of the quick disconnect fasteners as quickly as possible. The guide enclosure must be maintained spray-tight and if all of the fasteners are not tight, trouble will be encountered when missile is fired." In view of the 56 stud and 39 ring replacements per ship operating year, an increase of the on-board spare levels of the studs and rings and investigation of the use of noncorrosive materials are recommended.

3.2.7 Access Door, Oblong, P/N 1815516; Round, P/N 1807229

The oblong and round access doors afford access to the loaded cell for maintenance and test of the cell and missile. MDCS data identified 20 replacements of the oblong door on 13 FF-1052 ships at \$209 per replacement and three replacements of the round door at \$468 each. The primary failure mode of the doors is corrosion of the actuating pins, springs, and gasket seating surfaces.

The oblong door is not carried as an on-board spare, and neither are several of its components. The round access door, P/N 1807229, is spared on board.

To assure the capability of maintaining the spray-tight integrity of the launcher guides, spares of both the round and oblong doors should be carried on board. This would cost an additional \$209 per ship. As an alternative, deletion of the allowance for the round door and addition of an allowance for the oblong door appears justified in view of the approximately 7:1 reported replacement ratio. This would result in a decreased logistic burden of \$259 per ship, based on the different purchase prices of the two doors.

3.2.8 Safe-Fire Handle, P/N 1656707

The safe-fire handle is located on the aft closure frame and is mechanically connected to the firing-circuit disconnect switch. The handle is normally positioned and locked in "safe" and is moved to "fire" for system tests and missile firing. MDCS data reflect 29 handle replacements on 10 FF-1052s. In addition, five CASREPT reports specifically indicated problems with the handle assembly. Corrosion, with its attendant mechanical binding and electrical failure, has been the principal cause of handle assembly failures.

ORDALT 6803 effected improvements to the assembly, including a stainless steel handle and delrin-coated shaft. The primary handle assembly planned maintenance prior to ORDALT 6803 was weekly lubrication (MRC J-16 W-4), which required nine man-hours to accomplish. A new MRC, J-16 W-4, Card Number 46 DNDR W, is being utilized after installation of the ORDALT, but the weekly burden remains the same.

A review of the current MRC indicated that the major part of the procedure is expended in preservation of the security locks, which requires cleaning with solvent, soaking, and draining. This PMS action necessitates the expenditure of 468 man-hours annually per ship or, when viewed over the entire class, 21,528 man-hours per year, making it the second largest contributor to the ASROC Gunner's Mates' weekly PMS burden, as discussed in Section 3.10.

In view of these facts, a review of the safe-fire handle situation with emphasis on utilizing noncorrosive locks and re-engineering the PMS requirement is recommended.

3.2.9 Cover, Flexible, P/N 1806060

Replacement of 30 flexible covers on nine ships was attributed to normal wear and tear. Current on-board spare status (10 per ship) is considered adequate, and no DDEOC-related maintenance or ILS changes are indicated.

3.2.10 Rod Assembly, P/N 1656607

Twelve rod assembly replacements were reported on 7 ships. Further analysis showed that 7 of the 12 replacements occurred during the first 13 months after commissioning and that the other 5 occurred at random intervals throughout the cycle. Frequent replacement of this part is not anticipated during the DDEOC, and no maintenance or ILS changes are considered necessary.

3.2.11 Guide Improvements and Alterations

Several improvements directly affecting the reliability and maintainability of the guides have been identified. Most are in the form of Ordnance Alterations (ORDALTs) developed in response to the DART Program and are included in Fleet Modernization ORDALT Group W2230. ORDALTs 8105, 6803, and 8613 are anticorrosion improvements directly related to the guides. ORDALT 8105 was an interim modification to install foam rubber weather strips around launcher enclosures and provide additional drainage capability for the carriage. ORDALT 6803, developed in 1971, provided neoprene gaskets on the forward cell doors, a latching mechanism to keep the doors tightly closed, an improved safe-fire handle assembly, corrosion-resistant fittings (plastic standoffs), and a guide drain hole. Difficulties were encountered with the gaskets being inadvertently torn by maintenance personnel and being burned off by missile blast during firing evolutions. ORDALT 8613, which is currently under development, is an improvement to ORDALT 6803; it includes repositioning the gasket on the cell door versus the guide facing and using more durable, skin-coated neoprene gasket material. Installation cost and labor estimates are \$500 and 18 man-hours per launcher.

A significant modification to the bottom snubber assemblies is under development as ORDALT 8672. Included in this alteration will be newly designed hydraulic piston and sleeve assemblies, positive piston stops,

and bellows-type anticorrosive covers for the piston assemblies. This ORDALT is expected to be available in CY 1976 or early 1977; it is estimated that it will cost \$6000 and require 250 man-hours' installation time. ORDALT 8672 has been restricted to accomplishment by Naval Ordnance Station (NOS), Louisville, during Class "A" major overhaul of the guides.

ORDALT 7488, which provides water-removal filters on the 100-psi and 300-psi air supplies, will also effect improvements to the operability and maintainability of the guide pneumatics. This alteration will be discussed in more detail under the carriage analysis, Section 3.9.

The use of epoxy paints on guide surfaces is an additional anticorrosion action. Their use, however, is limited to guides undergoing Class "A" overhaul at NOS, Louisville.

It is recommended that these improvements be incorporated into the FF-1052 Class Launching Group prior to or during BOH.

3.3 LAUNCHER CARRIAGE, MK 7, MODS 2 AND 3, APL 005020017

The carriage is that portion of the ASROC Launcher between the lower base ring and the guides. It includes:

- Carriage Structure and Enclosure (Weathershield)
- Sector Gear Assembly
- Elevation/Depression Buffers and Buffer Pump
- Train Centering Pin and Train Buffers
- Missile and Rail Selection Relay Racks
- Firing Interrupter
- Heating and Cooling Manifolds and Hoses
- Train Gear Drives*
- Elevation Gear Drives*

Among the ASROC Launching Group components, the carriage ranked first in reported corrective-maintenance labor expenditures at 65.9 average ship man-hours per SOY and 23.6 average IMA man-hours per SOY, and second in replacement parts costs at \$736 per SOY. A total of 66 CASREPTs were reported against the carriage and its components during the data period.

As in the launcher guide, corrosion has been a very significant contributor to maintenance problems in the carriage. The following paragraphs contain analyses of historical component problems affecting the carriage assembly.

*Train and elevation power drives are discussed in Section 3.5.

3.3.1 Guide Drive Pin, P/N 1676875, and Associated Parts, P/Ns 1807288, 1815565, 12Z1180-29, and 1253742 Pc. 1

The guide drive (P/N 1676875) and associated parts provide a mechanical link between the torque tube and a selected guide to allow that guide to be elevated and depressed (see Figure 3-2). When a guide is selected for elevation, the guide drive pin is hydraulically rammed into the torque tube bushing; this action releases the elevation stow latch and activates the guide-drive-pin position switch (P/N 1253742 Pc. 1), which in turn activates an interlock to prevent engagement of any other guide. As the guide elevates, the guide drive pin is kept in engagement (under 4000 pounds of spring tension force) by riding on the curved track (P/N 1807288), which is mounted by screws (P/N 12Z1180-29) onto the track support (P/N 1815565).

Thirty (45 percent) of the 66 CASREPTs reported against the carriage were in response to malfunctions of one or more guide drive pins. MDCS data revealed 13 guide-drive-pin replacements on 9 ships, 15 track replacements on 9 ships, 10 track support replacements on 7 ships, and 9 switch replacements on 7 ships.

The most frequent symptoms of problems in this assembly are binding and misalignment of the guide drive pin due to corrosion, scoring, and lack of lubrication. The failure modes resulting from this malfunction include sheared tracks, broken track supports, cracked stiffeners, and broken drive-pin mounting bases.

The boot, P/N 1656021, which is also shown in Figure 3-2, is a protective device installed in the guide-drive-pin/elevation-stow-latch assembly. A total of 120 were replaced on FF-1052 ships. These replacements are due to normal wear and tear and weather exposure. Fleet interviews also indicated that the boots for guides 2 and 3 were often damaged by removal and replacement of the carriage enclosure's center panel. This problem should be solved by installation of ORDALT 7695, which includes a different center panel and personnel access door arrangement. The sparing level specified on the APL (i.e., four on-board spares) is considered adequate, and no extended operating cycle maintenance-related problems are anticipated.

Significant improvements to the guide drive pin assembly are under development. These are addressed collectively in Section 3.3.9.

3.3.2 Hydraulic Filter and Element, P/Ns 1284137 and 1778749, Rev. H

The filter and element are part of the elevation-stow-latch/guide-drive-pin hydraulic system. They function to filter the hydraulic fluid, indicate a clogged filter condition to the Launcher Captain's Control Panel (LCCP), and, in operational emergency, allow fluid to be channeled through a bypass valve. No CASREPTs were reported on either the fluid or the element. MDCS data indicate 8 filter replacements on 7 ships and 23 element replacements on 8 ships. The element is replaced if cleaning is no longer effective. No recurring failure mode was identified for the filter body. On the basis of these data and the fact that both the filter and element are spared on board, no changes in maintenance or ILS policy are considered necessary.

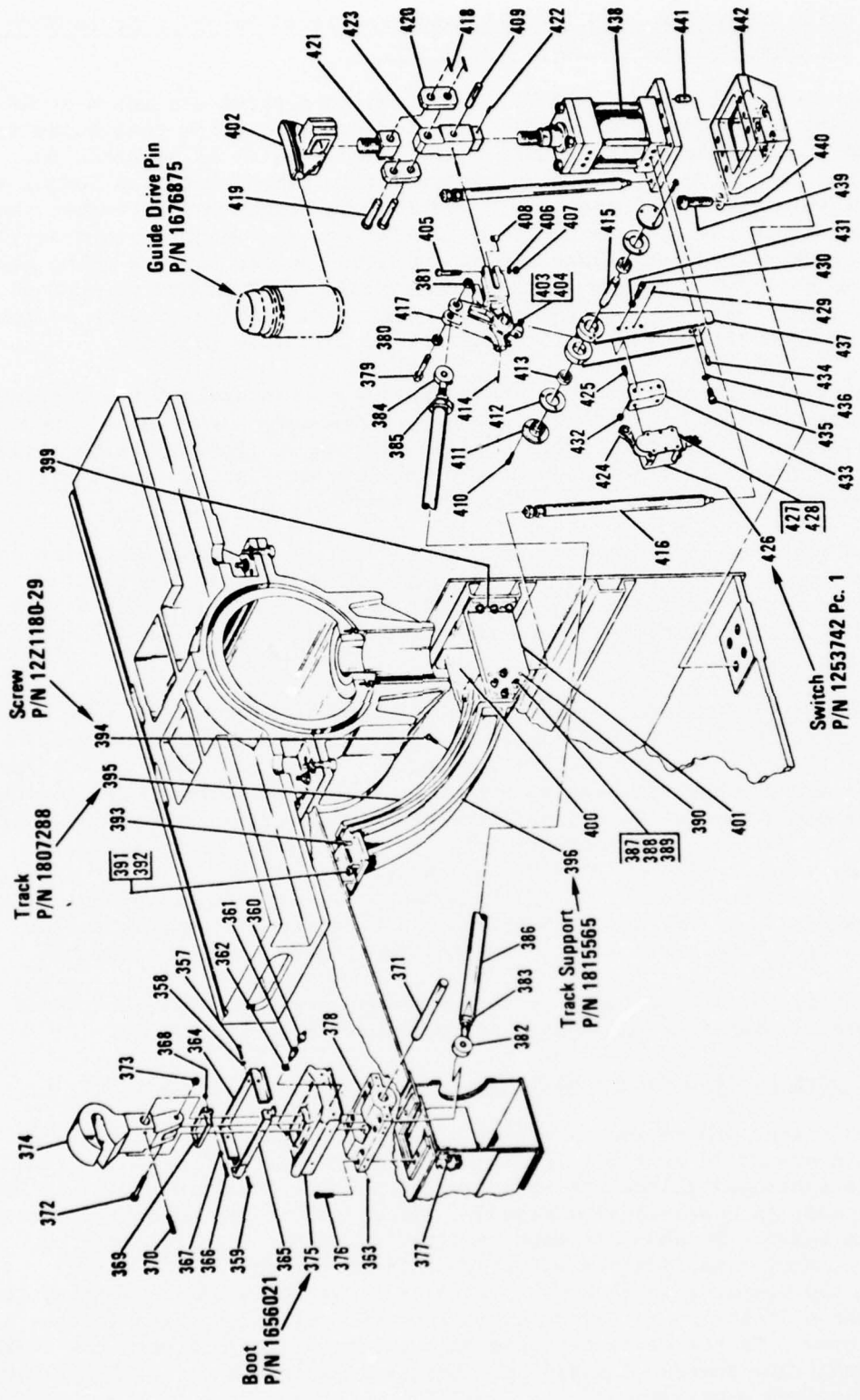

Figure 3-2. GUIDE DRIVE PIN ASSEMBLY

3.3.3 Air Motors, P/Ns 1655765 and 1656351

Two air motors, one for train P/N 1655765 and one for elevation P/N 1656351, are provided for local operation of the launcher during loading and maintenance operations. The two motors are identical except for internal gearing arrangements, which provide different output speeds. Both operate on the 100-psi launcher air supply.

Five CASREPTs were issued against the elevation air drive motor. No CASREPTs were reported on the train air drive motor. MDCS parts-usage data indicate a 3:1 replacement ratio between the elevation motors (21 replaced on 17 ships) and train motors (7 replaced on 6 ships).

The primary failure modes of the motors have been corrosion and clogging due to moisture in the air supply. The fact that the elevation motor contains idler gears and ring gears to step down the output speed could account for the different replacement rates experienced between the elevation and train air drive motors. Also, given the maintenance problems of the guide and quantity of PMS checks requiring elevation of the guides, the elevation air motor probably has a higher utilization factor than the train.

There were two air drive motor designs, one manufactured by Keller Tool Division of Gardner Denver Corporation and the other manufactured by Humphrey Products Company. The Gardner Denver types are grease-lubricated by Zerk fittings and are the preferred type according to NAVSEA technical personnel and Fleet interviews. Comments from NUSC, Newport indicate that the Humphrey motors have been deleted from production drawings and are being replaced in the Fleet through attrition.

Alterations that should improve the reliability of the air drive motors have been developed, and these will be discussed collectively with other carriage improvements in Section 3.3.9.

3.3.4 Air Lubricator, P/Ns 1807384 and 1807383

There are two Micro-Fog type lubricators installed in the carriage assembly. They are placed in the air supply lines and provide oil-mist lubrication to the pneumatic components in the guide and carriage. Lubricator P/N 1807384 functions in the 300-psi supply to lubricate the guide pneumatics. Lubricator P/N 1807383 functions in the 100-psi supply to lubricate the air motors in the carriage.

The 300-psi lubricator was replaced 12 times by 10 ships; the 100-psi lubricator 10 times by 6 ships. The primary reasons identified for replacement were leakage of the lubricator and failure to pass the PMS drip test, MRC J-16 M-1. The fact that no CASREPTs were reported against the lubricators indicates that Fleet technicians are able to detect problems and procure replacement parts prior to a complete failure. Therefore, no DDEOC-related maintenance or ILS changes are considered necessary.

3.3.5 Heating/Cooling Hoses, P/Ns MS 28741-16-2030 and MS 28741-16-2300

The heating/cooling hoses carry the guide heating and cooling solution. There are six of the "2030"* hoses and two of the "2300"* hoses installed in the carriage. MDCS data analysis identified 50 replacements of the "2030" hoses on 14 ships and 42 replacements of the "2300" hoses on 14 ships. Four CASREPTs were reported against these hoses. The most prevalent failure mode of the hoses has been rupture due to sea-water rotting and corrosion. The hose construction includes a metallic fiber reinforcing layer covered by a fabric layer. These fabric and metallic layers have suffered severe deterioration because of salt water/spray intrusion. In hoses examined during the ship visits, the fabric layer was completely rotted and the metallic layer had been reduced to an oxidized powder. These hoses were being replaced during the ongoing maintenance availability.

Current anticorrosion alterations and improvements to the carriage assembly should reduce the hose corrosion problem. (See Section 3.3.9 for carriage improvements.) The use of a noncorrosive-type hose construction could also improve long-term hose reliability.

The Navy Management Data List (NMDL) indicates that the hoses are no longer carried in the supply system and should be fabricated at a maintenance facility (IMA or depot). Because of the criticality and safety aspects of the heating and cooling system, replacement of all hoses during BOH and the fabrication of one additional hose of each type for use as on-board spares are recommended, pending the investigation of new hose materials.

3.3.6 Firing Interrupter Cable Housings and Couplings, P/Ns 1787748/1787769 and 1787743/1787768

The firing interrupter cable housings and couplings include the exterior housing and connectors for the train and elevation flexible-drive-cable inputs to the firing interrupter. The train housing, P/N 1787748, was replaced ten times on six ships; the train coupling, P/N 1787768, ten times on eight ships; the elevation housing, P/N 1787769, seven times on seven ships; and the elevation coupling, P/N 1787743, six times on six ships. Two CASREPTs were reported against all of these components.

The primary reason for replacement of these parts is corrosion from seawater entering the carriage. Proper accomplishment of MRC J-16-M8, together with improvements to the spray-tight integrity of the carriage, should reduce these replacements, and no extended-operating-cycle problems are anticipated.

*Hoses are referred to by the last four digits of their part number for purposes of brevity.

3.3.7 Missile Select Relay Rack and Rail Select Relay Rack -- Component Designation: 2A6 and 2A7

The 2A6 and 2A7 relay racks are mounted on the forward port and starboard sides of the carriage. They contain relays, stepping switches, and other electrical/electronic components to facilitate rail and missile selection and other functions. The two CASREPTs attributed to these racks were reported by the same ship in a 12-month interval and therefore represent no recurrent problems within the class. The only relay rack components appearing on the summary of frequently used parts were two relays. The Missile Selector Motor Control Relay, P/N 1788049, (component designation: 2A6-K1) was replaced seven times on six ships. This relay is spared on board, and its failure was considered random.

An additional relay that was replaced frequently was P/N 1704264 Pc. 3, replaced ten times on nine ships. This relay is recognized as a failure-prone item by NUSC, Newport, and it is adequately spared on board.

On the basis of these analyses, no significant relay rack problems are anticipated during the extended operating cycle.

3.3.8 Switch, P/N 1788141

Two switches are located in the elevation sector gear and provide Torque-Tube-Near-Zero and Torque-Tube-At-Zero indications. The switch was replaced 11 times on 8 ships, and no CASREPTs were reported against it. Corrosion again was identified as the recurring cause for replacement. On the basis of the on-board sparing level (one per ship) and number of replacements, no extended-operating-cycle-related problems are anticipated.

3.3.9 Carriage Improvements and Alterations

As in the case of the guide, several improvements to the carriage and its associated components are in various stages of development or installation. ORDALT 8105, which was discussed under guide improvements (Section 3.2.11), also provided gasket material for carriage enclosures as an interim fix. ORDALT 7695 is a follow-on to 8105, it provides for major improvements, including a new fiberglass carriage shield to prevent water entry into the carriage and to prevent gun-blast and wave damage to the launcher carriage. Figure 3-3 illustrates the carriage appearance before and after installation of this alteration. The estimated kit cost for this alteration is \$10,000, and anticipated IMA/yard installation time is 144 man-hours per launcher.

An improvement to ORDALT 7695 is currently being developed at the Naval Underwater Systems Center (NUSC), Newport. This improvement will alter the front panels by replacing the more than 90 bolts with dogging closure devices.

Installation of commercial-type air filters on the inlet side of the 100-psi and 300-psi air supplies is accomplished by ORDALT 7488. The filters are designed to remove water and other contaminants from the air supply and should significantly improve the reliability of the launcher pneumatic systems.

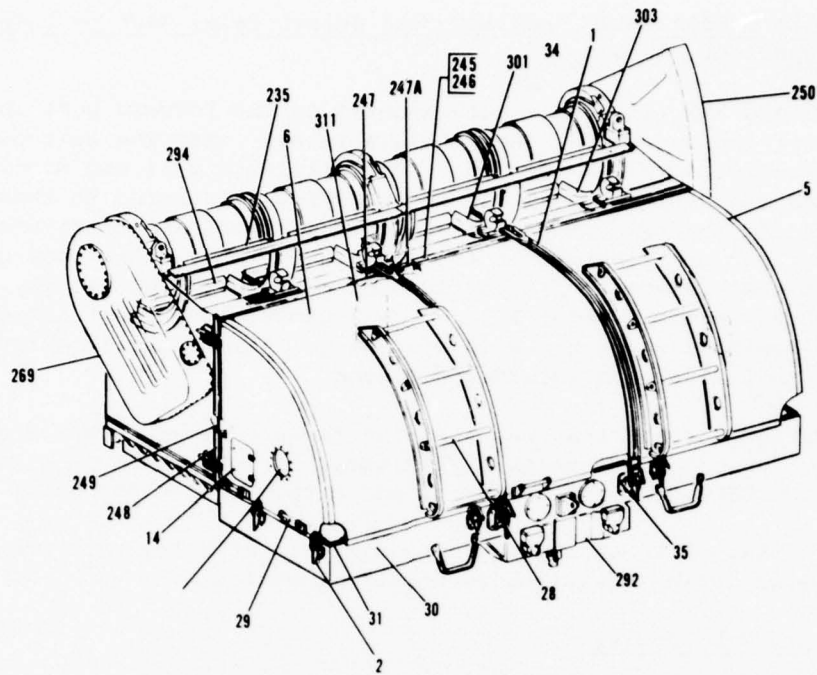

Before ORDALT 7695

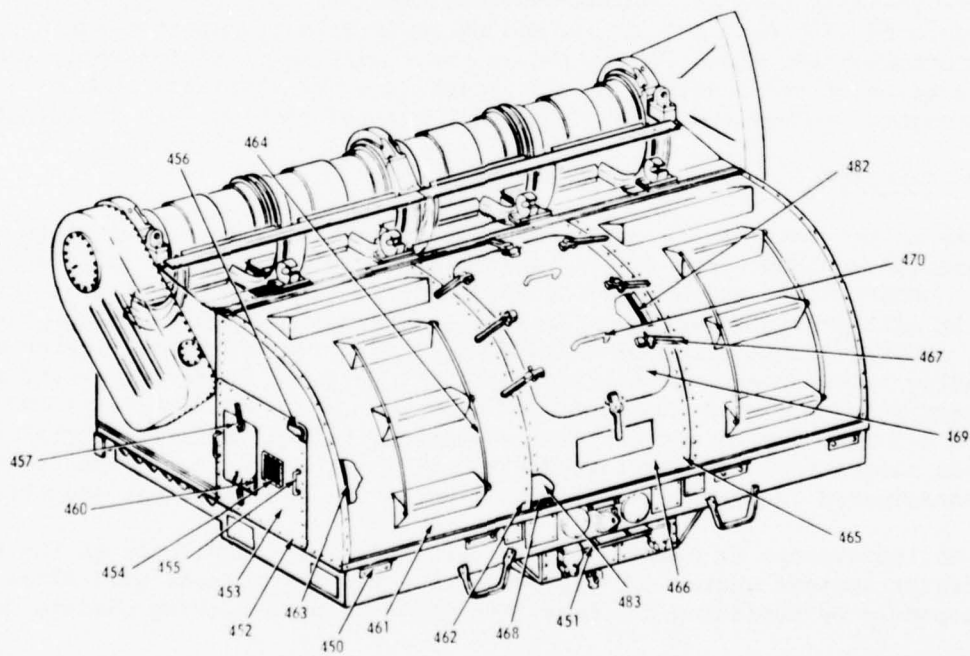

After ORDALT 7695

Figure 3-3. CARRIAGE SHIELD BEFORE AND AFTER ORDALT 7695

ORDALT 8670, a major alteration to the guide-drive-pin/elevation-stow-latch mechanism, is currently being developed. Planned for inclusion in this alteration are a newly designed guide drive pin that will require significantly less force to seat, new elevation stow latch bushings, sealed fastener bearings in the stow latch pivots, additional strength members, a new double-switching arrangement in the guide-drive-pin position mechanism, and a new guide-drive-pin lubrication system. Expected to be available in late 1976, this ORDALT entails \$6000 materials cost and 250-man-hours' installation time per launcher. It is recommended that these improvements be incorporated before or during BOH.

3.4 LAUNCHER CAPTAIN'S CONTROL PANEL (LCCP), MK 199, MODS 3, 4, AND 5, APL 005020013

The LCCP Mk 199 is the control panel for operating the ASROC Launcher from the local control station. Maintenance resource expenditures reported against it were significantly lower than those attributed to the guide and carriage. The figures per Ship Operating Year are 12.3 ship man-hours, 1.8 IMA man-hours, and \$360 parts cost. The 17 CASREPTs reported against the LCCP represent random part failures with the exception of the eight reported against the power drive amplifiers, which is the only problem component identified.

3.4.1 Power Drive Amplifiers, P/N 1877413

The power drive amplifiers accounted for four of the eight items on the summary of frequently used parts, as well as 50 percent of the CASREPTs. The amplifier itself was replaced 20 times on 14 ships at a cost of \$1130 each. Three amplifier relays, P/Ns 1676520, 1676519, and 1478760, also experienced significant replacement (see Appendix C). In addition to high relay-failure rates, problems have been experienced by Fleet personnel in adjustment of the 12 precision potentiometers and procurement of replacement parts. An alteration is currently under development at Northern Ordnance Division, Fairbanks-Morse Corporation, to replace the amplifiers with state-of-the-art equipment. Hardware for this alteration will cost approximately \$6000 and will be available for installation in late 1977. This alteration is recommended as a mandatory BOH requirement.

3.4.2 P-1 Plug, P/N 1788210

The P-1 plug is a fail-safe device which, when inserted in its receptacle in the LCCP, enables the firing circuit. Its replacement 12 times on 11 ships is attributed to normal wear and tear caused by frequent insertion and to operator handling errors. The plug is adequately spared on board, and no DDEOC-related problems are anticipated.

3.5 POWER DRIVES, ELEVATION MK 62, MODS 2 AND 3, AND TRAIN MK 61,
MODS 2 AND 3, APL 005020015

The Train and Elevation Power Drives include electric motors, hydraulic pumps, hydraulic motors, receiver regulators, and other equipment necessary to provide power to the train and elevation gear drives. The corrective maintenance burden of these equipments has been low, with averages of 10.6 Ship's Force man-hours per SOY, 1.5 IMA man-hours per SOY, and \$234 parts cost per SOY.

Analysis of the 12 power-drive CASREPTs and MDCS data did not reveal any repetitive failures. Most problems have been random failures occurring on one or two ships. The two items that met the selection criteria for frequently used parts are discussed below.

3.5.1 Pressure Switch, P/N 1778695

One switch located in each power drive provides loss-of-pressure protection to the supercharge high-pressure hydraulic system. A total of 32 switches were replaced by 19 ships primarily because of corrosion. The on-board sparring level of the switch is adequate, and installation of ORDALT 7695 should reduce replacements (see Section 3.3.9).

3.5.2 Filter Elements, P/N 1778749, Rev. H

Two filter elements per power drive remove contaminants from the hydraulic fluid. These elements are identical to those discussed for the carriage in Section 3.3. The element was replaced 32 times on 9 ships; no CASREPTs were submitted against it. The filter is replaced when clogging is indicated at the LCCP and cleaning of the elements is no longer effective. No DDEOC-related problems are anticipated.

3.6 SIMULATOR, MK 6, MOD 2, APL 005020014

The Mk 6 Simulator is located in the Launcher Captain's Control Station (LCCS) and is used to simulate the ASROC Launcher and Missile functions for purposes of training weapons control personnel. This equipment experienced very low maintenance-resource expenditures, with averages of 2.3 ship man-hours per SOY, 0.3 IMA man-hours per SOY, and \$26 per SOY in parts cost. The three simulator CASREPTs reported during the data period represent infrequent and random failure of electronic components. The eight replacements of the solenoid-operated rotary selector switch, P/N 1453294, represent only 17 percent of the item population and are not considered indicative of a recurrent problem.

3.7 TEST SET, ELECTRICAL SYSTEM MISSILE, MK 363, MODS 1 AND 3, APL 005020022

The Mk 363 test set is used to perform electrical tests on the ASROC missile in accordance with MRC J-16 M-14R or MRC J-16 M-16R. As in the case of the Mk 6 Simulator, the maintenance burden for this equipment was very

low (see Table 3-1). No CASREPTs were submitted against the test set, and only one part exhibited frequent usage. The cable assembly, P/N 1453482, which is used to connect the set to the test receptacle, was ordered 18 times on 12 ships. Ship surveys indicated that replacement of the cable is due to normal wear and tear and is not a problem, since it is spared on board.

A NAVSEACEN test set turn-around program has been established. This provides an IMA test set repair and calibration capability to ensure the operability and maintainability of this equipment.

3.8 DUMMY DIRECTOR, MK 6 MOD 1, APL 006020524

The Dummy Director is used to control the ASROC Launcher during the performance of various launcher tests. It experienced a low maintenance burden, with averages of 0.5 ship man-hour per SOY, 1.3 IMA man-hours per SOY, and \$230.8 parts cost per SOY. Only one CASREPT was identified for this equipment, and there was no evidence of frequent parts usage.

Consultation with NAVSEACENLANT indicated that the Dummy Director is sometimes overlooked during ship overhauls and that including it in the established Mk 363 Test Set Turn-Around Program would preclude such omissions and frequent return of the equipment to distant repair facilities for minor problems. This action is considered prudent, and its investigation is recommended.

3.9 MAJOR RESTORATIVE MAINTENANCE FOR ASROC LAUNCHING GROUP

3.9.1 Maintenance Trends

To determine if any significantly increasing or unusual trends in the Launching Group maintenance burden should be anticipated during the extended cycle, the MDCS histories of 10 FF-1052 Class ships having the longest operating time between fitting out and overhaul were examined. If such trends occurred, they would signal a need for further evaluation and possibly extensive restorative maintenance during the cycle. These 10 ships and their respective operating cycles are tabulated as follows:

- | | |
|-----------------------|-----------------------|
| • FF-1053 - 48 months | • FF-1062 - 51 months |
| • FF-1052 - 50 months | • FF-1064 - 48 months |
| • FF-1056 - 48 months | • FF-1068 - 53 months |
| • FF-1059 - 59 months | • FF-1071 - 48 months |
| • FF-1061 - 52 months | • FF-1072 - 53 months |

The measures examined over the extended data period were labor actions, deferred actions, outside deferrals, ship man-hours, outside man-hours,

number of parts cards, and parts cost. The per-ship average for each measure was computed for each quarter of operation, normalized to the ship's commissioning date.

Tables 3-2 and 3-3 depict the data printouts generated by this method for the guide and carriage APLs. These data indicate that no significantly increasing or unusual trends in maintenance were experienced by these ten ships.

3.9.2 Major Overhaul Program for ASROC Launcher

To analyze the ASROC major maintenance further, the ASROC Launcher Major Overhaul Program was examined. This program, begun in 1969, is described by NAVORD (being updated to NAVSEA) Instruction 4710.1. The program is managed by NAVSEA (Code 661) and includes standardized procedures for inspecting and "scoring" ASROC Launchers to determine which should be removed from ships during their regular overhaul and returned to the Naval Ordnance Station (NOS) Louisville for complete Class "A" overhaul. A three-volume manual (NAVORD OD 18383) specifying launcher removal, overhaul, replacement, and post-overhaul testing was also completed for use by shipyards and NOS, Louisville.* Originally, the major overhaul program included Class "A" overhaul of the guides and selected components at NOS, Louisville, with the carriage overhaul being performed by the shipyards. This process evolved to the current practice of removing the entire launcher and shipping it to Louisville for Class "A" overhaul.

To determine which launchers should be designated for major overhaul at NOS, Louisville, the NAVSEACENS conduct Machinery Inspections. Machinery Inspection procedures set forth in NAVORD INSTRUCTION 4710.1 include extensive tests and inspections to establish the operability and maintainability of the launcher. These inspections are normally conducted as soon as a ship returns from deployment just prior to ROH.

The Type Commanders (TYCOMs) designate launchers for inspection on the basis of age or material condition. The Machinery Inspection is then performed by the appropriate NAVSEACEN, and the inspection results are submitted with a recommendation for or against including the launcher in the Major Overhaul Program. Any launcher whose composite score is lower than 175 will normally be recommended. On the basis of the recommendations, the TYCOM nominates the launcher for major overhaul to NAVSEA (Code 661), who makes the final decision on the basis of available resources.

Consultation with NAVSEA (Code 661) revealed that the average cycle length between major ASROC Launcher overhauls has been four to six years for bow-mounted launchers and six to eight years for amidships-mounted launchers. A review of the ASROC DART quarterly brief sheet, dated October 1975, revealed an average of approximately 14 major launcher overhauls per year since FY 1969. The goal of the program has been to

*NAVSEA (Code 661) reported that this manual is being scheduled for revision.

12/29/75

GUIDE WK 7
CID 005020021

PER SHIP AVERAGE

QUARTER AFTER COMMISSIONING	LABOR ACTIONS	DEFERRAL ACTIONS	OUTSIDE DEFERRALS	SHIP MAN-HOURS	OUTSIDE MAN-HOURS	NO. PARTS CARDS	PARTS COSTS	SHIPS OPERATING PER QUARTER
QUARTER 1	.700	.300	.100	.590	.000	1.100	40.39	10.0
QUARTER 2	1.900	1.400	1.400	3.970	.000	1.900	67.11	10.0
QUARTER 3	.200	.300	.200	2.150	.000	2.300	121.82	10.0
QUARTER 4	.700	.400	.000	2.600	.000	2.700	39.40	10.0
QUARTER 5	.500	.200	.000	3.950	4.200	2.700	532.91	10.0
QUARTER 6	.700	.400	.100	7.200	.000	3.200	153.02	10.0
QUARTER 7	.900	.500	.100	4.150	.000	2.300	78.71	10.0
QUARTER 8	1.100	1.000	.300	12.670	.000	4.200	142.38	10.0
QUARTER 9	1.900	1.600	.200	3.750	.400	4.700	196.96	10.0
QUARTER 10	1.900	1.600	.300	16.150	.000	3.300	169.99	10.0
QUARTER 11	1.400	.500	.000	33.050	.110	1.800	204.09	10.0
QUARTER 12	1.600	1.000	.200	6.150	.110	3.000	229.25	10.0
QUARTER 13*	1.700	1.100	.300	35.670	93.340	7.300	8,562.69	10.0
QUARTER 14	1.200	.400	.200	2.930	1.300	2.600	165.19	10.0
QUARTER 15	1.600	1.000	.100	5.780	.000	2.300	117.42	10.0
QUARTER 16	1.200	.600	.300	5.464	.000	1.538	144.00	9.1
QUARTER 17	2.475	2.500	.714	5.432	.000	.714	79.72	5.6
QUARTER 18	1.667	1.667	.667	2.233	.000	1.333	66.48	3.0
QUARTER 19	1.176	1.176	1.176	3.647	.000	1.176	37.83	1.7
QUARTER 20	.000	.000	.000	.000	.000	2.000	197.19	1.0
QUARTER 21	.000	.000	.000	.000	.000	1.000	8.50	0.0
QUARTER 22	.000	.000	.000	.000	.000	.000	0.00	0.0
QUARTER 23	.000	.000	.000	.000	.000	.000	0.00	0.0

Notes: *Figures in this quarter are distorted by the fact that one ship, FF-1059, replaced all 16 bottom snubbers under JSN A-206. The total reported parts cost of this action was \$82,000 and total labor was 268.4 man-hours. (A total of 32 instead of 16 snubbers appear in the data, thus accounting for the \$82,000 figure.)

Table 3-2. QUARTERLY MAINTENANCE BURDEN, GUIDE

12/28/75

CARRIAGE, Mk 7
CID 005020017

PER SHIP AVERAGE

QUARTER AFTER COMMISSIONING	LABOR ACTIONS	DEFERRAL ACTIONS	OUTSIDE DEFERRALS	SHIP MAN-HOURS	OUTSIDE MAN-HOURS	NO. PARTS CARDS	PARTS COSTS	SHIPS OPERATING PER QUARTER
QUARTER 1	2,200	2,000	200	1,410	300	500	28.54	10.0
QUARTER 2	600	600	200	2,860	300	1,000	29.85	10.0
QUARTER 3	1,000	500	400	33,490	300	2,100	94.78	10.0
QUARTER 4	2,400	2,100	400	13,410	300	1,500	265.61	10.0
QUARTER 5	1,000	400	100	12,370	4,160	2,300	547.96	10.0
QUARTER 6	1,200	1,000	600	5,430	300	1,100	224.79	10.0
QUARTER 7	1,400	1,300	200	21,080	1,420	2,800	195.49	10.0
QUARTER 8	2,200	1,800	400	7,810	4,200	2,300	346.74	10.0
QUARTER 9	1,300	1,000	300	3,090	4,000	2,800	166.02	10.0
QUARTER 10	1,500	1,800	500	64,830	13,400	3,600	482.77	10.0
QUARTER 11	2,200	1,800	600	18,260	4,500	4,100	410.20	10.0
QUARTER 12	1,500	1,300	200	10,860	2,300	1,600	237.09	10.0
QUARTER 13	1,800	1,000	600	13,760	300	5,200	1,110.03	10.0
QUARTER 14	3,200	2,200	600	23,950	300	7,700	686.87	10.0
QUARTER 15	2,500	2,600	600	20,720	300	1,500	71.08	10.0
QUARTER 16	2,747	2,098	330	7,033	769	654	46.84	9.1
QUARTER 17	4,821	2,857	357	24,926	300	1,964	264.16	5.6
QUARTER 18	1,667	1,000	467	25,667	11,667	5,000	448.58	3.0
QUARTER 19	1,765	1,765	1,765	2,647	300	1,176	51.84	1.7
QUARTER 20	5,000	3,000	2,000	27,400	300	4,000	111.78	1.0
QUARTER 21	300	300	300	300	300	300	0.00	0.0
QUARTER 22	300	300	300	300	300	300	0.00	0.0
QUARTER 23	300	300	300	300	300	300	0.00	0.0

Notes: *This sudden increase in parts cost was caused by the fact that one ship, FF-1068, replaced a brake assembly at a cost of \$8040.
 **Only one ship was active during this quarter.

Table 3-3. QUARTERLY MAINTENANCE BURDEN, CARRIAGE

provide the ability to accomplish 25 major launcher overhauls (fleet-wide) per year. NAVSEA (Code 661) anticipated achievement of this goal in FY 1977.

Appendix F is a tabulation of FF-1052 Machinery Inspection dates, scores, discrepancies, and the results of the decision regarding inclusion of the particular launcher in the Major Overhaul Program. Of the 23 inspections of FF-1052 launchers, 8 (35 percent) were identified for Class "A" major overhaul.

The discrepancies indicated in these 23 reports were examined to identify common problems. The primary problem areas identified by these reports are the same ones which were identified as problems by the CASREPT and frequently-used-parts analysis and for which improvements have been or are being developed -- i.e., snubbers, guide drive pins, air motors, power drive amplifiers, and corrosion.

3.9.3 Pre-Overhaul Tests and Inspections (POT&I)

In addition to the Machinery Inspection conducted by the NAVSEACENS, a Launcher Pre-Overhaul Test and Inspection (POT&I) is conducted nine to ten months prior to the scheduled ship overhaul. This inspection, normally performed by shipyard personnel, is conducted to determine the Launcher's requirements for shipyard overhaul and has routinely consisted of visual inspection and selected PMS tests. This inspection appears to be redundant in light of the Machinery Inspections conducted by the NAVSEACENS. It is recommended that standard inspection procedures and requirements for use in pre-overhaul testing, in abbreviated form, be used as a pre-SRA inspection.

3.10 ASROC GUNNER'S MATE (GMT-0891) MANNING AND RELATIVE PMS BURDEN

Analysis and evaluation of shipboard manning levels are generally considered beyond the scope of the SMAs. However, comments from both Naval Underwater Systems Center (NUSC), Newport and fleet personnel indicated potential problems in ASROC GMT manning. NUSC, Newport commented that on the basis of past experience, the existing PMS actions have not been performed as required because of lack of manpower. Two of the three FF-1052 Class ships surveyed reported that it would be very difficult to maintain the ASROC Launching Group properly with fewer than four trained maintenance personnel.

Liaison with the Fleet and with OPNAV 124E2 identified the current Ship's Manning Document (SMD) allowance of GMT-0891 personnel on FF-1052 Class ships as seven. On the other hand, a review of the 11 April 1976 Enlisted Distribution Verification Report, NAVPERS 1080.14, for SURFLANT ships revealed the manning data presented in Table 3-4. It is evident that the Current Allowance, Current Navy Manning Plan (NMP), and Currently On Board figures are all well below the SMD allowance.

Table 3-4. ASROC GUNNER'S MATE (GMT-0891)
MANNING LEVELS AS OF
11 APRIL 1976

Hull	Current Allowance	Current NMP	Currently On Board
1056	5	2	3
1059	3	2	3
1061	3	2	3
1068	3	2	2
1072	3	2	3
1075	3	2	3
1078	3	2	2
1079	3	2	2
1080	3	2	3
1081	3	2	2
1082	3	2	3
1084	3	2	2
1085	3	2	2
1089	3	2	3
1090	3	2	2
1091	3	2	2
1092	3	2	2
1093	3	2	2
1094	3	2	3
1095	3	2	3
1096	3	2	2
1097	3	2	2
Average 2.45 per ship			

The total ASROC Gunner's Mate weekly PMS burden for the ASROC Launching Group, Mk 16, Mods 5 and 6, calculated as shown in Appendix G, is 72.85 man-hours. If a ship were manned at the SMD allowance level, this figure would translate to an average weekly burden of 10.4 PMS hours per Gunner's Mate. If, on the other hand, a ship were manned at a level equal to the mean of the Currently On Board Column of Table 3-4, 2.45 men, the weekly

burden per Gunner's Mate would be 29.73 PMS hours. Assuming a five-day in-port work week, the 29.73 figure translates to a daily burden of 5.95 PMS hours per Gunner's Mate, a figure that is greater than half (57 percent) of the weekly burden at the SMD manning level.

This brief analysis is presented to illustrate the rapidly mounting individual PMS workload associated with reduced manning. While not every aspect of personnel manning was explored, the burden figures derived, in conjunction with comments from NUSC Newport and the Fleet, signal a potential manning problem that could adversely affect ASROC Launching Group maintenance during the extended operating cycle.

It is recommended that the ASROC Gunner's Mate manning level anticipated throughout the extended operating cycle be accurately determined. If this level is insufficient for achievement of Launching Group PMS requirements, appropriate action should be taken either (1) to increase the man-hours available for maintenance by eliminating collateral assignments and other less vital tasks normally assigned to ASROC Gunner's Mates or (2) to assign priorities to maintenance requirements so that at least the most critical actions are accomplished as specified.

CHAPTER FOUR

CONCLUSIONS AND RECOMMENDATIONS

4.1 OVERVIEW

The ASROC Launching Group has historically been a high-maintenance-burden system. The equipments included in this analysis accounted for 136 CASREPTs, 26,282 corrective maintenance man-hours, and \$339,499 in parts costs, as reported by the 46 ships in the Class over the five-year data period.

The principal cause of maintenance problems has been corrosion resulting from the spray-tight versus water-tight design of the ASROC Launcher and the heavy wave-loading environment associated with bow-mounted equipments on FF-1052 Class ships. The launcher has also suffered from occasional gun-blast damage caused by its proximity to the 5"/54 Gun Mount. These problems have manifested themselves as structural, mechanical, and electrical failures in the various launcher components. Under the cognizance of the ASROC Launcher DART Program, several reliability and anti-corrosion improvements have been developed. Implementation of these improvements, together with the other actions recommended in this chapter, should greatly improve the reliability and maintainability of the ASROC Launching Group.

4.2 CONCLUSIONS

The principal conclusion of the analysis is that the ASROC Launching Group can be maintained at an acceptable level of reliability throughout the extended operating cycle provided the following actions are taken:

1. Identified repairs and alterations necessary to bring Launching Group equipments up to current design standards are accomplished prior to or during BOH.
2. ASROC Gunner's Mate manning levels are maintained at a level consistent with the proper performance of Launching Group maintenance requirements throughout the extended operating cycle.
3. The effectiveness of the numerous alterations in preventing corrosive degradation of Launching Group equipments is periodically assessed throughout the operating cycle by means of a pre-SRA inspection.

It is also concluded that one standardized Launching Group Pre-Overhaul Test and Inspection (POT&I) procedure should be developed from the existing POT&I Machinery Inspection to provide more accurate and consistent identification of overhaul requirements and to eliminate redundancy of efforts. An abbreviated version of this procedure should be utilized for the pre-SRA inspection.

4.3 RECOMMENDATIONS

Recommendations are presented individually in six categories:

1. Depot Improvements
2. BOH Repairs and Alterations
3. R&M Improvements
4. IMA Improvements
5. ILS Improvements
6. PMS Changes

4.3.1 Depot Improvements: Pre-Overhaul Inspection

Recommendations

The POT&I test procedures and the Machinery Inspection procedures should be combined into one procedure and conducted during the regular ship POT&I. The combined procedure should determine the following:

- Necessity for Class "A" Major Overhaul at NOS, Louisville
- Lesser shipyard overhaul requirements (if entire Launcher is not eligible for Class "A" Major Overhaul)
- Other necessary repairs or assistance

It is further recommended that the NAVSEACENS be designated in conjunction with the shipyards as the inspecting agencies for the ASROC Launching Group.

Rationale

The BOH overhaul inspections and decisions must take into account the fact that there will be no opportunity to accomplish major overhaul work on the ASROC Launching Group (work requiring more than six weeks) during the extended operating cycle of EOC ships. Currently there are two ASROC Launching Group pre-overhaul inspections in existence -- one a Machinery Inspection conducted by NAVSEACENS to determine eligibility and necessity for major Class "A" overhaul, and the other a POT&I conducted to determine Class "B" and other shipyard overhaul requirements.

While each inspection has merit and can determine overhaul needs, adoption of one pre-overhaul Launching Group inspection program would eliminate redundant efforts and afford more consistent and accurate definition of overhaul requirements. NAVSEACEN personnel, who work frequently with the launchers under their cognizance, are very familiar with the material condition and alteration status of individual launchers. They are often called upon by individual ships and Type Commanders to provide technical assistance in response to CASREPTs and to rectify other Launching Group problems. NAVSEACEN personnel also have an intimate knowledge of ORDALTS (as they are often the installation activity) and enjoy technical rapport with the various ASROC In-Service Engineering Activities (ISEAS).

For these reasons, it is concluded that the NAVSEACEN personnel should be designated in conjunction with shipyard personnel to conduct the Launching Group Pre-Overhaul Inspection.

4.3.2 BOH Repairs and Alterations

4.3.2.1 Repairs

4.3.2.1.1 Launcher Guide, Mk 7

Recommendation. All guides should be given a Class "A" overhaul at NOS Louisville.

Rationale. The launcher guides have accounted for the greatest reported parts-dollar expenditures and second highest labor expenditure of the Launching Group components and have accounted for the second highest number of CASREPTs.

The honeycomb aluminum construction of the guide is very susceptible to corrosion and should be verified as completely sound before the extended operating cycle is entered.

Installation of snubber ORDALT 8672 has been restricted to accomplishment by NOS, Louisville during Class "A" major overhaul. In view of the magnitude of past snubber problems, this alteration is recommended as a mandatory requirement for BOH.

In addition, the utilization of epoxy paints on the guides has been limited to those undergoing Class "A" overhaul at NOS, Louisville. The use of this paint on DDEOC ships' Launchers prior to completion of BOH is considered highly desirable for minimizing corrosion problems.

4.3.2.1.2 Carriage Assembly, Mk 7 (Including Power Drives)

Recommendation. The carriage assembly and its components should be given either a Class "A" overhaul at NOS, Louisville or lesser repairs by the applicable shipyard, and this decision should be based on the results of the Pre-Overhaul Inspection conducted by the cognizant NAVSEACEN.

Rationale. The carriage assembly represented the highest reported MDCS labor burden and second highest parts expenditure of all launcher components and has accounted for the greatest number of CASREPTs. To ensure its operability and maintainability throughout the extended operating cycle, a thorough overhaul is considered necessary.

Class "A" overhaul of the carriage assembly would be the best preparation for the DDEOC cycle. However, Class-wide Class "A" overhaul is not considered justified when the following are considered: (1) the recent major improvement to the carriage enclosure (ORDALT 7695) and planned and installed improvements to carriage components, including the pneumatic system (ORDALT 7488) and guide drive pin mechanism (ORDALT 8670); (2) the fact that only 35 percent of the FF-1052 Class launchers inspected in the past have been designated for Class "A" overhaul; and (3) the Fleet-wide limitation of 25 major Launcher overhauls per year. Therefore, only those

launcher carriage assemblies whose pre-overhaul inspection results indicate that Class "A" overhaul is required should receive such overhaul.

4.3.2.1.3 LCCP, Mk 199

Recommendation. The LCCP should be inspected during the POT&I and overhauled as necessary to ensure its Class "B" (or to design specifications) condition.

Rationale. The LCCP is critical to the operation of the ASROC Launching Group and is ranked third among Launching Group components in terms of corrective maintenance man-hour and part-dollar expenditures over the five-year MDCS history. It should be within design material and operational condition prior to the commencement of the extended operating cycle.

4.3.2.1.4 Launcher Stand, Mk 107

Recommendation. The launcher stand should be repaired in accordance with pre-overhaul inspection results.

Rationale. Analysis of the launcher stand revealed no significant problem areas and low MDCS maintenance burden figures.

4.3.2.1.5 Simulator, Mk 6

Recommendation. The simulator should be repaired in accordance with pre-overhaul inspection results.

Rationale. No significant simulator problem areas were revealed in the analysis. The pre-overhaul inspection should determine if major rework is required on an individual basis.

4.3.2.1.6 Test Set, Mk 363, and Dummy Director, Mk 6

Recommendation. The test set and dummy director should be repaired in accordance with pre-overhaul inspection results.

Rationale. No significant maintenance problems were identified for either of these equipments.

4.3.2.2 Alterations

Timely and professional installation of ASROC Launching Group ORDALTS is essential to ensure achievement of maximum system reliability, maintainability, and operability throughout the extended operating cycle. The installation of ORDALTS during BOH (and throughout the extended operating cycle) will require coordination between cognizant technical activities, NAVSEA, TYCOMs, and overhaul activities in determining what agency will install the ORDALT. Alterations applicable to the ASROC Launching Group are listed in Appendix D.

The following alterations represent significant improvements to the reliability and maintainability of the ASROC Launching Group and are recommended as mandatory for accomplishment before or during the BOH:

ORDALT Number	Short Title	Estimated Kit Cost (\$ Thousands)	Estimated Labor (Man-Hours)
7695	Carriage Enclosure	10.0	144
8672	Snubber Modification	6.4	250
8670	Guide Drive Pin Alt.	6.0	250
Pending	New Power Drive Amp.	6.0	4
7488	Air Filters	0.3	80
Pending	Improved Carriage Front Panel Closure (Dogging) Devices	Unknown	Unknown
8613	Improved Cell Door Gaskets	0.5	18

Note: ORDALTS 6451, 8455, and 8671 and their concurrent Shipalts FF-1052-30K, FF-1052-73K, FF-1052-259K involve ASROC Launcher/Loader interface and will be discussed in the ASROC handling-equipment SMA.

Note: Consultation with NAVSEA (Code 06G5) indicated that ORDALT 8896, the HARPOON modification to the ASROC Launcher, is planned for installation during the next overhaul of applicable FF-1052 ships. This alteration requires an estimated \$85,000 in material costs and 960 man-hours' installation time, and must be considered by BOH planners.

4.3.3 R&M Improvements

4.3.3.1 Heating and Cooling Hoses, P/Ns MS28741-16-2030 and MS 28741-16-2300

Recommendation. Recommendations are as follows:

- Long Term. The use of hoses constructed with noncorrosive reinforcing materials should be investigated.
- Near Term. Present hoses should be replaced during BOH and one spare hose of each type fabricated during BOH for each ship.

Rationale. These hoses carry the guide heating and cooling fluid and as such are important to the safety of the loaded weapons. Ninety-two replacements of the two types of hoses were reported by 14 ships. Four CASREPTs were submitted against the hoses, and they were also listed as a discrepancy on most Major Overhaul Machinery Inspection Reports. The primary reason for the problems identified was deterioration of the hoses due to the corrosive effects of sea spray, particularly on the metallic reinforcing layer. The use of hoses constructed of noncorrosive or less corrosive materials could reduce hose deterioration and thereby improve heating/cooling system reliability. Procurement (via depot or IMA fabrication) of one spare hose of each type during BOH is recommended to provide a near-term organization-level capability to replace worn units while new hose materials are being investigated.

4.3.3.2 Safe-Fire Handle Assembly

Recommendation. Recommendations are as follows:

- Investigate the procurement of noncorrosive security locks for the handle assembly, or procure a second set of locks to alternate with the existing set.
- Investigate amending and combining the Safe-Fire Handle Assembly PMS lubrication requirement, J-16 W-4, with J-16 W-1 or other existing weekly maintenance.

Rationale. Although ORDALT 6803 installed a stainless steel handle and delrin-coated shaft in the handle assembly, the PMS burden to lubricate the assembly has remained unchanged at nine man-hours per week, making it the second largest contributor to the ASROC Gunner's Mate PMS workload, adjusted to a weekly basis. A review of the procedure required by the W-4 action indicates that most of the time and effort are consumed in preservation of the security locks on the handle assemblies. The procurement of noncorrosive locks would eliminate the time-consuming weekly cleaning, soaking, and draining requirement. If suitable noncorrosive locks are not available, procurement of an additional lock set would allow weekly alternating of the locks in service and preservation of the not-in-service locks at a location removed from the Launcher at a convenient time. Either of these actions would substantially reduce the handle lubrication effort; leaving only the oiling and actuation of the handle assembly itself.

This remaining effort, together with the altered lock maintenance, could be combined with other existing weekly PMS such as J-16, W-1 (just before step "1" on MRC 75 DKZS W) provided no security or safety precautions are violated. This combining action would eliminate the requirement to elevate each guide via the elevation motor and, coupled with the change in locks above, would reduce the current nine man-hours expended on handle assembly and lock lubrication. The estimated burden increase to PMS action J-16 W-1 is two man-hours, yielding a net reduction in the weekly PMS man-hour burden of seven hours.

4.3.4 IMA Improvements

4.3.4.1 Pre-SRA Inspection

Recommendation. A pre-SRA inspection criterion should be developed from the combined Machinery Inspection/POT&I Inspection and this inspection should be conducted by the appropriate NAVSEACEN on each FF-1052 Class ASROC Launching Group prior to each SRA during the extended operating cycle.

Rationale. The ASROC Launching Group equipments, particularly the Mk 112 Launcher, have historically suffered greatly from the effects of corrosion. Numerous improvements, including a new carriage shield, new guide drive pin assembly, and new guide bottom snubbers, are being installed to combat the corrosion problem. Implementation of a pre-SRA Launching Group Inspection will provide a condition-assessment capability to accomplish the following:

- Monitor the effectiveness of the numerous alterations in preventing corrosive degradation of Launching Group Equipments
- Identify any unanticipated reliability or maintainability problems arising during the extended operating cycle
- Make optimum use of IMA and shipyard maintenance facilities to correct any problems identified and especially to correct any corrosive degradation of Launching Group equipments

The inspection should be an abbreviated version of the combined Machinery Inspection and POT&I Inspection and be performed by the appropriate NAVSEACEN, based on the same rationale presented in Section 4.3.1.

Given the ASROC Launching Group situation of potential maintenance manning problems, numerous major alterations, and historical corrosion problems, a pre-SRA inspection is essential to the achievement of the DDEOC Program goal of improved material condition.

4.3.4.2 Dummy Director, Mk 6

Recommendation. An investigation should be made into the inclusion of the Dummy Director in the NAVSEACEN Turn-Around Program.

Rationale. Liaison with NAVSEACEN LANT indicated that there is currently a NAVSEACEN Turn-Around Program for repair of the 363 Test Set. They also stated that inclusion of the Dummy Director in this program is feasible and that it would be prudent to preclude omission of this equipment during overhauls and frequent return of the equipment to distant repair facilities for minor problems. Investigation of this action is currently under way.

4.3.5 ILS Improvements

4.3.5.1 Aft Blast Door Quick-Disconnects

Recommendation. Recommendations are as follows:

- Long Term. The procurement of noncorrosive quick-disconnect fasteners should be investigated.
- Near Term. The on-board allowance of quick-disconnect studs and rings should be increased.

Rationale. The integrity and tightness of these fasteners is essential to maintaining the spray-tight integrity of the cells' aft closures. The total reported replacements of the stud (7108) and the ring (4877) can be extrapolated to class-wide average replacement rates of 56 studs and 39 rings per SOY. APL data indicate current on-board allowance levels of 20 studs and 16 rings. On the basis of these historical usage figures, increasing the current allowances to 60 studs and 40 rings in the near term would better ensure shipboard replacement capability. In the long term, procurement of quick-disconnects fabricated from noncorrosive materials, such as stainless steel, should eliminate problems with these parts and improve launcher reliability and spray-tight integrity.

4.3.5.2 Guide Access Door, Oblong, P/N 1815516

Recommendation. An on-board spare allowance of one oblong Guide Access Door should be established.

Rationale. Proper operation and sealing of these access doors are essential to maintaining the spray-tight integrity of the guide. Twenty of these doors were reported replaced by 13 FF-1052 Class ships. The round access door, P/N 1807229, is spared on board and was reported replaced only three times. Sparing both doors (i.e., increasing the allowance of the oblong door from zero to one) is the most prudent action to prevent interior guide corrosion. This would result in an increased logistics burden of \$209 per ship. An alternative -- deletion of the spared round door and substitution of the oblong door -- is considered justified on the basis of the 7:1 replacement ratio of the oblong-to-round doors. This action would result in a decreased logistics burden of \$259 per ship based on the different purchase prices of the doors.

4.3.5.3 Thermostatic Switch, P/N 1676917/1788840, and Temperature-Sensing Device, P/N 1676905/1807582

Recommendation. The following actions are recommended:

- Review the supply support of the switches to verify the compatibility of the switches to devices.
- Establish an on-board allowance for the correct thermostatic switch and include its device on the APL.

Rationale. Two temperature-sensing devices and thermostatic switches are listed in the ASROC IPB. The new procurement thermostatic switch, P/N 1676917, is listed in the guide APL, but its associated device is not. Neither the alternate device nor switch, P/Ns 1807582/178840, are on the APL. Ship surveys indicated that the two different device-switch combinations do not fit the same mounting and that when ordering replacements, one could receive either type.

Seventy-one switches, P/N 1676917, were reported replaced on 17 ships during the data period. Since the switch is a missile-safety-related item, providing one on-board spare is considered justified.

4.3.5.4 ASROC Gunner's Mate Manning

Recommendation. NUSC, Newport, together with BUPERS, should review ASROC Gunner's Mate (GMT-0891) manning requirements on FF-1052 Class ships to determine minimum manning requirements and the anticipated manning level that will be maintained during the extended operating cycle. If the anticipated level is insufficient to meet Launching Group PMS requirements, appropriate action should be initiated to increase the GMT man-hours available for maintenance by eliminating collateral duties and other less vital tasks normally assigned ASROC GMTs, or if necessary, priorities should be assigned to maintenance requirements so that at least the most critical actions are completed as scheduled.

Rationale. Comments from both NUSC, Newport and FF-1052 Class ship surveys signaled problems with ASROC GMT manning. NUSC stated that on the basis of past experience, PMS actions have not been performed as required because of a lack of manpower. Two of the three 1052 ships surveyed reported that it is very difficult to adequately maintain the Launching Group equipments with fewer than four trained maintenance personnel. The SMD allowance for GMTs is seven; however, a review of the Enlisted Distribution Verification Report of 11 April 1976 indicated that the average ASROC GMT manning level on SURFLANT FF-1052s was 2.45 per ship. At this manning level, the 72.85-man-hour weekly PMS burden for GMTs equates to a daily burden of 5.95 hours per man, assuming a five-day work week. This burden is considered high and indicative of the need to accomplish the above-recommended actions. Failure to provide sufficient man-hours for PMS of the Launching Group will result in failure to complete maintenance as required (if at all) and resultant decreased reliability and availability of the equipments.

4.3.6 PMS Changes

4.3.6.1 MRC J-16 M-7, "Inspect and Lubricate Forward Cell Doors"

Recommendation. The sequence of operations should be changed to effect inspection and verification of proper snubber oil levels and nitrogen pressure prior to verification of correct and smooth snubber operation.

Rationale. Since proper and smooth snubber operation is partially dependent on a correctly filled hydraulic system and charged accumulator, it is more functionally correct to perform those actions before verifying snubber operation.

4.3.6.2 MRC J-16 S-4R - "Replenish Hydraulic Fluid and Bleed Entrapped Air ..."

Recommendation. The periodicity code should be changed from "S-4R" to "R" and the following criteria for accomplishment added: "Accomplish this maintenance requirement as directed by MRC J-16 M-7 and whenever bottom snubber hydraulic fluid level or nitrogen pressure are suspect." J-16 M-7 and J-16 S-4R [to be (R-n)] should be made related maintenance.

Rationale. Performance of this PMS action is currently determined by occurrence of one of two events: (1) the passage of six months since its most recent accomplishment; or (2) observation of an unsatisfactory hydraulic fluid level or nitrogen pressure during the monthly PMS action, J-16 M-7. The M-7 action contains specific directions for checking the hydraulic fluid level and accumulator nitrogen pressure and requires the accomplishment of S-4R if unsatisfactory readings are obtained. This monitoring action, in conjunction with other routine system operability tests, is sufficient to identify situations requiring accomplishment of S-4R. This change will decrease the hard-time PMS burden by 28 man-hours per SOY; from a class-wide point of view, over a five-year operating cycle, a reduction of 6440 hard-time PMS man-hours will be realized.

4.3.6.3 MRCs J-16 R-2 and J-16 A-3R (Launching Rail Cylinder)

Recommendation. Specific comments regarding inspection for corrosion and leakage of the cylinder and piston should be included in the post-firing MRC, J-16 R-2, and the annual/post-firing check, J-16 A-3R.

Rationale. The cylinder was reported replaced 13 times on 7 FF-1052 ships and was the subject of two CASREPTs. There are currently no spare cylinders carried on board. Because of its location within the cells, the cylinder is virtually inaccessible when the cell is loaded, and could thus be easily overlooked. Currently, there are no PMS checks of the cylinder. Adding specific inspection checks of the cylinder to the above-listed MRCs will call the maintenance personnel's attention to this component and permit timely identification and correction of problems. The estimated increase to the PMS burden from this change is 0.2 man-hour.

REFERENCES AND SOURCES OF INFORMATION

1. NAVWEPS OP 2385, Volume 1 - Launcher, Mk 112, Mods 1, 2, 3, and 4; Power Control Panel, Mk 188; LCCP, Mk 199, Mods 1-5
2. NAVWEPS OP 2385, Volume 2 - Train Power Drive, Mk 61, Mods 0 and 1; Elevation Power Drive, Mk 62, Mods 0 and 1; Power Drive Amplifier, Mk 153
3. NAVWEPS OP 2385, Volume 3 - Launcher and Missile Simulator, Mk 6, Mods 0, 1, and 2
4. NAVORD OP 2385 - IPB, Volume 1 - Launcher, Mk 112; Power Control Panel, Mk 188; LCCP, Mk 199
5. NAVORD OP 2385 - IPB, Volume 2 - Train Power Drive, Mk 61, Mods 0, 1, 2, and 3; Elevation Power Drive, Mk 62, Mods 0, 1, 2, and 3; Power Drive Amplifier, Mk 153
6. NAVORD OD 18383, Volume 1 - Removal and Shipyard Overhaul
7. NAVORD OD 18383, Volume 2 - Depot Component Overhaul
8. NAVORD OD 18383, Volume 3 - Shipyard Installation and Operational Tests
9. SECAS Ordnance Configuration System/Equipment-To-APL Listing, 4 August 1975.
10. Ship Alteration Management Information System (SAMIS) Data (Amalgamated MIP/TIP and Ship Alteration Master for FF-1052 Class, January 1976).
11. Fleet Modernization Program Ordnance Improvement Plan for FY 1977, 5 August 1975.
12. DART Quarterly Reports for ASROC Launcher, March 1975 and October 1975.
13. MDCS - Five-Year Data Base (1 January 1970 - 31 December 1974).
14. MDCS - Five-Year Narrative Summaries, FMSO 4790-S2704-A-06 (1 January 1970 - 31 December 1974).
15. CASREPT Narrative Summaries, FMSO Report 4400.28 Series (1 January 1970 - 31 December 1974.)

16. FF-1052 Critical Equipments List Development, ARINC Research Corporation, 18 August 1975.
17. Type Commanders' Coordinated Shipboard Allowance List (TYCOM COSAL), SURFLANT (19 May 1975) and SURFPAC (19 August 1975).
18. Trip Report of Ship Surveys (FF-1072, 1075, and 1082) and NAVSEACENLANT Visit, November 1975.

APPENDIX A

DDEOC ACTION TABLE

This appendix summarizes action information for each of the recommendations discussed in this report.

1. ACTION ITEM		2. DDEOC EVALUATION		3. ACTION ITEM DESCRIPTION
a. NO.	b. TITLE	a. APPROVED YES	b. FURTHER STUDY NO	
1.	Pre-Overhaul Inspection			Combine existing Machinery Inspection and POT&I Inspection to standardize procedures and eliminate redundancy. Task NAVSEACENS to perform the combined inspection in conjunction with shipyard
2.	Class "A" Overhaul of Launcher Guides			Class "A" overhaul all FF-1052 launcher guides at NOS Louisville during BOH
3.	ASROC Launching Group POT&I for BOH			Perform combined pre-overhaul inspection on all FF-1052 MK-7 Carriages, MK 107 Stands, MK 199 LCCPs, MK 6 simulators, MK 363 Test Sets, and MK 6 Dummy Director to determine necessary Class "A", "B", "C" and lesser repairs.
4.	NAVSEACEN Turn-Around Program			Investigate inclusion of the Dummy Director, MK 6 in the NAVSEACEN Turn-Around Program.
5.	BOH Mandatory ORDALTS			Accomplish the following ORDALTs prior or during BOH: OAs 7695, 8672, 8670, 7488, 8613, New Power Drive Amplifier ORDALT, Improved Carriage Front Panel Dogging Devices.
6.	Heating and Cooling Hoses			<p><u>Near Term:</u></p> <p>Have one spare hose of each type fabricated during BOH for each FF-1052 Class ship.</p> <p><u>Long Term:</u></p> <p>Investigate the use of hoses constructed from non-corrosive reinforcing material</p>
7.	Safe/Fire Handle Assembly			Investigate procurement of non-corrosive security locks or an alternate set of locks. Investigate amending and combining handle assembly lubrication requirement with other existing weekly maintenance.

NOTE: DEVELOPING ACTIVITY FILL IN THE FOLLOWING BLOCKS: 1a, b; 3; 4; 5b,c,d IF KNOWN; 6a, IF REQUIRED FOR CONTINUATION

DDEOC ACTION TABLE

3. DESCRIPTION	4. REPORT REFERENCE (PARA.)	5. NAME/CODE OF PERSON HAVING RESPONSIBILITY				6. SCHEDULING DATES			7. FUNDING IMPLICATIONS	8. PRIORITY
		a. DDEOC	b. NAVSEC	c. NAVSEA	d. OTHER	a. REQD.	b. START	c. COMP.		
pection rdize dancy. combined shipyards.	4.3.1.	X		661	PERA CRUDES					
launcher y BOH	4.3.2.1.1	X		661	NOSL					
inspection MK 107 ulators, my Directors A", "B",	4.3.2.1.2 thru 4.3.2.1.6	X			NAVSEA- CEN					
ummy N Turn-	4.3.4.2	X			NAVSEA- CEN					
Ts prior to , 8670, plifier t Panel	4.3.2.2	X		661						
pe fabric- 52 Class	4.3.3.1	X			NUSC NEWPORT					
onstructed materials -corrosive set of d combin- require- maint-	4.3.3.2	X			NUSC NEWPORT					

CONTINUATION OF DEVELOPING ACTIVITY TASK; 7; 8, AS NECESSARY.

OTHER	6. SCHEDULING DATES			7. FUNDING IMPLICATIONS	8. REMARKS	9. ACTUAL ACTION TAKEN
	a. REQD.	b. START	c. COMP.			
RA JDES						
SL						
WSEA- N						
SEA-						
SC WPORT						
SC WPORT						

1. ACTION ITEM		2. DDEOC EVALUATION			3. ACTION ITEM DESCRIPTION	4. REPORT REFERENCE (PART)
a. NO.	b. TITLE	a. APPROVED YES	NO	b. FURTHER STUDY		
8.	Pre-SRA Inspection				Develop a Pre-SRA Launching Group Inspection from the combined pre-overhaul inspection. Task NAVSEACENS to perform on each FF-1052 prior to each SRA	4.3.4.
9.	Aft Blast Door Quick Disconnects				<p><u>Near Term:</u></p> <p>Increase the onboard spare allowance to 60 studs and 40 rings.</p> <p><u>Long Term:</u></p> <p>Investigate procurement of non-corrosive quick disconnects.</p>	4.3.5.
10.	Oblong Guide Access Door				Establish an onboard spare allowance of one oblong access door, P/N 1815516.	4.3.5.
11.	Thermostatic Switch and Temperature Sensing Device				Review the supply support of switches to verify the compatibility of switches to devices. Establish an onboard allowance for the correct thermostatic switch and include its device on the Guide APL.	4.3.5.
12.	ASROC Gunner's Mate Manning				Review ASROC Gunner's Mate (GMT- 0891) manning requirements on FF-1052 ships and determine anticipated extended operating cycle manning levels. If this level is insufficient to accomplish the 73 PMS weekly manhours, take action to eliminate GMT duties not related to their primary function area, and if necessary prioritize PMS requirements.	4.3.5.
13.	MRC J-16, M-7 (Card # 75 DKZD M) "...Inspect door seals, oil levels, and nitrogen pressure of bottom snubbers.... "				Change sequence of procedure to effect inspection and verification of proper snubber oil level and nitrogen pressure prior to verification of correct and smooth snubber operation.	4.3.6.
14.	MRC J-16, S-4R (Card # 75 DLAK S) "Replenish hydraulic fluid and bleed entrapped air in bottom snubbers; charge cell accumulator with nitrogen..."				Change periodicity code from "S-4R" to "R-n"	4.3.6.

NOTE: DEVELOPING ACTIVITY FILL IN THE FOLLOWING BLOCKS: 1a, b; 3; 4; 5b,c,d IF KNOWN; 6a, IF REQUIRED FOR CONTINUATION OF DEVELOPMENT

DDEOC ACTION TABLE

	4. REPORT REFERENCE (PARA.)	5. NAME/CODE OF PERSON HAVING RESPONSIBILITY				6. SCHEDULING DATES			7. FUNDING IMPLICATIONS	8. REMA
		a. DDEOC	b. NAVSEC	c. NAVSEA	d. OTHER	a. REQD.	b. START	c. COMP.		
overhaul perform A	4.3.4.1	X		661	NAVSEA- CENS					
ance to	4.3.5.1				NUSC NEWPORT			\$8.64 per ship		
corrosive										
ance of 516.	4.3.5.2							\$209 per ship		
tches witches a static the	4.3.5.3				NUSC NEWPORT					
0891) hips and erating vel is PMS liminate primary	4.3.5.4	X			NUSC NEWPORT BUPERS					
ffect oper essure and	4.3.6.1	X			NUSC NEWPORT					
R" to	4.3.6.2	X			NUSC NEWPORT					

ATION OF DEVELOPING ACTIVITY TASK; 7; 8, AS NECESSARY.

2

5. VING	6. SCHEDULING DATES			7. FUNDING IMPLICATIONS	8. REMARKS	9. ACTUAL ACTION TAKEN
	d. OTHER	a. REQD.	b. START			
NAVSEA-CENS						
NUSC NEWPORT				\$8.64 per ship		
NUSC NEWPORT				\$209 per ship		
NUSC NEWPORT BUPERS						
NUSC NEWPORT						
NUSC NEWPORT						

1. ACTION ITEM		2. DDEOC EVALUATION		3. ACTION ITEM DESCRIPTION	4. RE REFERENCE (PAGE)
a. NO.	b. TITLE	a. APPROVED YES	NO		
15.	MRC J-16, R-2 (Card # 75 DLAX R) and MRC J-16, A-3R (Card #44 DHHC A)				Add specific comments to inspect Launching Rail Cylinder for corrosion or leakage.

NOTE: DEVELOPING ACTIVITY FILL IN THE FOLLOWING BLOCKS: 1a, b; 3; 4; 5b,c,d IF KNOWN; 6a, IF REQUIRED FOR CONTINUATION OF DEVELOPMENT

DDEOC ACTION TABLE

4. REPORT REFERENCE (PARA.)	5. NAME/CODE OF PERSON HAVING RESPONSIBILITY				6. SCHEDULING DATES			7. FUNDING IMPLICATIONS	8. REM
	a. DDEOC	b. NAVSEC	c. NAVSEA	d. OTHER	a. REQD.	b. START	c. COMP.		
4.3.6.3 osion	X			NUSC Newport					

ATION OF DEVELOPING ACTIVITY TASK; 7; 8, AS NECESSARY.

2

HAVING		6. SCHEDULING DATES			7. FUNDING IMPLICATIONS	8. REMARKS	9. ACTUAL ACTION TAKEN
A	d. OTHER	a. REQD.	b. START	c. COMP.			
	NUSC Newport						

APPENDIX B

MIP AND MRC COMPARISON

This appendix presents the MIPs delineating ASROC Launching Group PMS requirements and an MRC Comparison Table listing recommended PMS changes. PMS actions for which changes are recommended are marked with a  symbol on the MIP page border.

LAUNCHING GROUP, ASROC Mk 16 Interim MIP for Mod 5		REFERENCE DOCUMENTS OP 2385 Vol 1, OP 2385 Vol 2, OP 3347, Launching Servicing Photoprint Book, OD 45737, OD 3000, NAVORD INST. 4855.20		DATE April 1976	
NOTE: See last entry for applicable ORDALTs covered in this and previous developments.					
SYSKOM MRC CONTROL NO.	MAINTENANCE REQUIREMENT	PERIODICITY CODE	SKILL LEVEL	MAN HOURS	RELATED MAINTENANCE
75 DKYQ D	ASROC LAUNCHER HEATING AND COOLING SYSTEM 1. Check heating and/or cooling temperature and pressure systems. 2. Monitor heating and/or cooling system temperatures and record maximum cell temperature readings. 3. Monitor and record heating and/or cooling fluid inlet and outlet pressures and temperatures.	D-1	GMG/ GMTSN MM3	0.5	None
				0.5	
75 DKYR D	ASROC LAUNCHER MK 112 1. Perform operational checkout. NOTE: Perform this MR daily or as soon as conditions and time permit.	D-2R	GMG/ GMT3 GMG/ GMTSN	1.1	None
				1.1	
75 DKZS W	CARRIAGE MK 7 1. Clean and inspect cable drum covers and wiper seals; lubricate cable drum covers.	W-1	GMG/ GMT3 2GMG/ GMTSN	1.0	None
				2.0	
73 DFHK W	ASROC LAUNCHER MK 112 1. Compare train and elevation stow positions against recorded values in gunnery log; book.	W-2	GMG/ GMT3 GMG/ GMTSN	0.3	None
				0.3	
75 DKZT W	CARRIAGE MK 7 1. Lubricate the three front carriage enclosure latch assemblies. 2. Lubricate ROTATE THROUGH STOP.	W-3	GMG/ GMT3 GMG/ GMTSN	0.7	None
				0.7	

(Page 1 of 8)

SYSCOM MRC CONTROL NO.	MAINTENANCE REQUIREMENT	PERTODICITY CODE	SKILL LEVEL	MAN HOURS	RELATED MAINTENANCE
△ 46 DNDR W	ASROC LAUNCHER MK 112 1. Lubricate SAFE-FIRE switch handle assembly and padlock.	W-4	GMG/ GMT3	3.0	None
			2GMG/ GMTSN	6.0	
46 DNDS W	STAND MK 107 1. Check training circle heater elements.	W-5	GMG/ GMT3	0.1	None
			2GMG/ GMTSN	0.2	
46 DNDU W	CARRIAGE MK 7 1. Test operation of train and elevation air drive motor.	W-6	GMG/ GMT3	0.5	None
			GMG/ GMTSN	0.5	
75 DKZY W	ASROC LAUNCHER HEATING AND COOLING SYSTEM 1. Test heating system thermostat operation.	W-7	GMG/ GMT3	0.6	D-1
			MM3	0.6	
75 DKZZ W	ASROC LAUNCHER MK 112 1. Test launcher temperature alarm system.	W-8	GMG/ GMT3	0.2	None
			GMG/ GMTSN	0.2	
75 DLAA W	CARRIAGE MK 7 1. Lubricate elevation stow latch linkages, stow latch pins, guide pin rollers, guide drive pin tracks, bell cranks, operating rods, and guide drive pin bushings.	W-9R	GMG/ GMT3	1.4	None
			GMG/ GMTSN	1.4	
	NOTE: Perform this MR whenever rail selected light window fails to function correctly, when misalignment is suspected, or once a week minimum.				
	NOT USED	W-10			
75 DLAB W	AC MK 53, RI MK 43, LCCP MK 199, ASROC LAUNCHER MK 112 1. Perform remote MEST, POWER-ON, and POWER-OFF tests.	W-11 **	GMG/ GMT1	1.0	None
			GMG/ GMT2	1.0	
			GMG/ GMT3	1.0	
	** A management aid: Perform this MR on a different cell each week so that each cell is tested on a minimum of once every 8 weeks.		STG2	1.0	
			2STG3	2.0	
			2STGSN	2.0	

(Page 2 of 8)

SYSKOM MRC CONTROL NO.	MAINTENANCE REQUIREMENT	PER O-DICITY CODE	SKILL LEVEL	MAN HOURS	RELATED MAINTENANCE
75 DKYT M	CARRIAGE MK 7 1. Inspect hydraulic fluid levels of train and elevation sumps, and air lubricators. 2. Inspect air lubricators for proper operation.	M-1	GMG/ GMT3 2GMG/ GMTSN	1.0 2.0	None
75 DKYV M	CARRIAGE MK 7 1. Test elevation guide drive pin hydraulic pressure system.	M-2	GMG/ GMT3 2GMG/ GMTSN	0.3 0.6	M-3
46 DMZQ M	ASROC LAUNCHER MK 112 1. Test launcher performance. 2. Perform dynamic test on launcher using dummy director mode of operation.	M-3	GMG/ GMT3 2GMG/ GMTSN	3.8 7.6	None
75 DKYY M	ELEVATION POWER DRIVE MK 62 1. Test elevation free fall accumulator for proper nitrogen pressure charge. **A management aid: This MRC is not applicable after accomplishment of ORDALT 7095, and if ASROC Launching Group Mk 16 Mod 4 and launchers Serial No. 257 and higher are installed.	M-4 **	GMG/ GMT3 GMG/ GMTSN	0.7 0.7	M-7
75 DKYZ M	CARRIAGE MK 7 1. Test guide drive pin accumulator 2A10-UA1 for proper nitrogen charge.	M-5	GMG/ GMT3 GMG/ GMTSN	0.4 0.3	M-2
46 DMZS M	ASROC LAUNCHER MK 112 1. Test train stow and elevation tram positions.	M-6	GMG/ GMT3 2GMG/ GMTSN	1.0 2.0	W-2
75 DKZD M	GUIDE MK 7 1. Inspect and lubricate forward cell doors, door hinges, and rail and door actuating mechanism. 2. Inspect door seals, oil levels, and nitrogen pressure of bottom snubbers. 3. Inspect aft (blast) covers and lubricate latch assemblies and all guide access doors.	M-7	GMG/ GMT3 3GMG/ GMTSN	3.2 9.6	None

(Page 3 of 8)

SYS COM MRC CONTROL NO.	MAINTENANCE REQUIREMENT	PERIODICITY CODE	SKILL LEVEL	MAN HOURS	RELATED MAINTENANCE
75 DKZE M	GUIDE MK 7	M-8	GMG/	0.7	None
	1. Lubricate guide support bearings, torque tube support bearings, firing interrupter flexible cables, shafts, dogs of center access hatch, and both side doors.		GMT3 2GMG/ GMTSN	1.4	
73 DFJC M	ASROC LAUNCHER MK 112	M-9	GMG/	0.3	None
	1. Lubricate launcher stand bearings and roller path.		GMT3 GMG/ GMTSN	0.3	
75 DLLV M	ASROC LAUNCHER HEATING AND COOLING SYSTEM	M-10	GMG/	1.0	None
	1. Test fluid freezing temperature.		GMT3 BT3	1.0	
	2. Test fluid salinity.		2GMG/ GMTSN	2.0	
	NOT USED	M-11			
75 DKZJ M	ASROC LAUNCHER MK 112	M-12R	GMG/	3.0	None
	1. Check train and elevation bench mark.		GMT3 2GMG/ GMTSN	6.0	
	NOTE: Perform this MR monthly, whenever cell is empty, after firing, or during yearly missile upkeep period.				
75 DKZK M	AC MK 38, RT MK 43, LCCP MK 199, ASROC LAUNCHER MK 112	M-13 **	GMG/	1.0	None
	1. Perform local MEST, POWER-ON, and POWER-OFF tests.		GMT1	1.0	
			GMG/	1.0	
			GMT2 GMG/ GMT3	1.0	
			STG2	1.0	
	** A management aid: Perform this MR on a different cell each month so that each cell is tested a minimum of once every 8 months.		2STG3	2.0	
			STGSN	1.0	

(Page 4 of 8)

SYSCOM MRC CONTROL NO.	MAINTENANCE REQUIREMENT	PERIODICITY CODE	SKILL LEVEL	MAN HOURS	RELATIVE MAINTENANCE
75 DLAF Q	CARRIAGE MK 7, ELEV POWER UNIT MK 62, TRAIN POWER UNIT MK 61 1. Lubricate train centering stop pin assembly. 2. Check fluid level of elevation depression buffer reservoir. 3. Check oil level in elevation power unit reduction gear housing. 4. Lubricate elevation air drive motor. 5. Check oil level in train power unit reduction gear housing. 6. Lubricate train air drive motor.	Q-1	GMG/ GMT3 GMG/ GMTSN	1.1 1.1	None
75 DMCQ Q	STAND MK 107 1. Lubricate training circle and train drive pinion gear.	Q-2	GMG/ GMT3 GMG/ GMTSN	1.0 1.0	None
73 DFJJ Q	CARRIAGE MK 7 1. Lubricate elevation buffer arm bearing. 2. Inspect, clean, and lubricate elevation sector gear and drive pinion.	Q-3	GMG/ GMT3 GMG/ GMTSN	1.4 1.4	None
46 DNDX Q	ASROC LAUNCHER MK 112 1. Check fluid level in train buffers; clean and lubricate buffer pin and roller. 2. Clean and inspect launcher hydraulic and pneumatic lines and fittings. 3. Inspect heating and cooling hoses.	Q-4	GMG/ GMT3 GMG/ GMTSN	2.0 2.0	None
75 DLAH S	CARRIAGE MK 7 1. Lubricate elevation gearbox. 2. Lubricate elevation brake assembly. 3. Replace air filter 25 micron filter elements.	S-1	GMG/ GMT3 GMG/ GMTSN	2.0 2.0	S-2
A3 DCHX S	CARRIAGE MK 7 1. Lubricate train gearbox and train brake assembly.	S-2	GMG/ GMT3 GMG/ GMTSN	0.5 0.5	S-1

(Page 5 of 8)

SYSOM MRC CONTROL NO.	MAINTENANCE REQUIREMENT	PERIODICITY CODE	SKILL LEVEL	MAN HOURS	RELATED MAINTENANCE
75 DLAJ S	<p>CARRIAGE MK 7</p> <p>1. Inspect hydraulic fluids in train and elevation power drive systems.</p> <p>** A management aid: Perform this MR after power drives have been secured for the preceding 12 hours.</p>	S-3 **	GMG/ GMT3 GMG/ GMTSN	1.0 1.0	M-7
 75 DLAK S	<p>GUIDE MK 7</p> <p>1. Replenish hydraulic fluid and bleed entrapped air in bottom snubbers; charge cell accumulator with nitrogen, one each cell.</p> <p>NOTE: Perform this MR semi-annually or as directed by MRC M-7.</p>	S-4R	GMG/ GMT3 3GMG/ GMTSN	3.5 10.5	M-7
<u>46</u> DMZU S	<p>ASROC LAUNCHER MK 112</p> <p>1. Test launcher performance.</p>	S-5	GMG/ GMT1 2GMG/ GMTSN	24.0 48.0	M-3
75 DLAN S	<p>ASROC LAUNCHER MK 112</p> <p>1. Clean and inspect stand junction box 2A10.</p> <p>NOTE: Perform this MR semi-annually or after launcher has been exposed to heavy seas or inclement weather for prolonged period of time.</p> <p>** A management aid: On DDG-31 class, add 2 men, 2.0 M/H and tools as required for removal of boiler uptake protective cover.</p> <p>On DD-719 class add 0.5 M/H and tools as required for removal of exhaust vent.</p>	S-6R **	GMG/ GMT3 GMG/ GMTSN	1.5 1.5	None
75 DLAP A	<p>TRAIN RECEIVER REGULATOR MK 46</p> <p>1. Clean, inspect, and lubricate train receiver regulator internal gearing, shafting, and external response couplings and splines.</p>	A-1	GMG/ GMT3 GMG/ GMTSN	1.0 1.0	A-2

(Page 6 of 8)

SYSCOM MRC CONTROL NO.	MAINTENANCE REQUIREMENT	PERIODICITY CODE	SKILL LEVEL	MAN HOURS	RELATIVE MAINTENANCE
75 DLAQ A	ELEVATION RECEIVER REGULATOR MK 47 1. Clean, inspect and lubricate elevation receiver regulator internal gearing, shafting, and external response couplings and splines.	A-2	GMG/ GMT3 GMG/ GMTSN	1.0 1.0	A-1
△ 44 DHHC A	ASROC LAUNCHER MK 112 1. Clean, inspect and lubricate interior of cell and working parts. NOTE: Perform this MR after each firing; unfired empty cells shall be serviced once a year minimum and unfired loaded cells shall be unloaded annually for servicing.	A-3R	GMG/ GMT3 2GMG/ GMTSN	8.0 16.0	None
75 DLAS A	ASROC LAUNCHER MK 112 1. Lubricate and inspect firing interrupter assembly.	A-4	GMG/ GMT3 3GMG/ GMTSN	1.5 4.5	A-5
75 DLAT A	CARRIAGE MK 7 1. Lubricate train and elevation firing interrupter take-off gears.	A-5	GMG/ GMT3 GMG/ GMTSN	0.5 0.5	A-4 M-11
46 DNDV A	MISSILE SIMULATOR MK 6 1. Clean and inspect simulator. NOTE: Perform this MR annually or when corrective maintenance necessitates opening panels for repairs.	A-6R	GMG/ GMT2 GMG/ GMTSN	1.0 1.0	None
75 DLAU A	ASROC LAUNCHER MK 112 1. Clean and inspect interior of relay rack missile selector box 2A6. 2. Clean and inspect interior of relay rack rail selector box 2A7. NOTE: Perform this MR annually or after launcher has been exposed to heavy seas or inclement weather for prolonged period of time. NOT USE)	A-7R A-8R	GMG/ GMT3 GMG/ GMTSN	2.5 2.5	None

(Page 7 of 8)

SYSCOM MRC CONTROL NO.	MAINTENANCE REQUIREMENT	POSITION CODE	SKILL LEVEL	MAN HOURS	RELATED MAINTENANCE NAME
75 DMCR A	ASROC LAUNCHER MK 112 1. Remove temperature sensing devices. 2. Test and calibrate the cell temperature sensing devices. NOTE: Perform these MRs when cells are empty.	A-9R	GMG/ GMT3 SN3	2.0 2.0	None
75 DLAW A	LCCP MK 199 1. Clean and inspect launcher captain's control panel.	A-10	GMT2 GMTSN	1.5 1.5	None
73 DFKR R	ASROC LAUNCHER MK 112 1. Perform pre-firing checkout. 2. Perform pre-firing launcher dynamic checkout. 3. Verify pre-fire SAFE-FIRE handle operation. NOTE: Perform this MR prior to firing.	R-1	GMG/ GMT1 ST3 GMG/ GMT2	0.6 0.6 0.6	None
75 DLAX R	ASROC LAUNCHER MK 112 1. Perform ASROC launching system post-fire checks. 2. Test guide mechanism operation of rail and restraining latch. 3. Perform guide mechanism operation test on snubbers. NOTE: Perform this MR after firing. ORDALTs: 5916, 5915, 6122, 6280, 6506, 6715, 6803, 7095, 7488, 7695, 7934, 8180	R-2	GMG/ GMT2 STG3	2.0 2.0	None

SYSTEM, SUBSYSTEM, OR COMPONENT		REFERENCE PUBLICATION		DATE	
Launching Group, ASROC Mk 16 Interim MIP for Mod 6		OP 2385 Vol 1, OP 2385 Vol 2, OP 3347, OD 3000, NAVORD INST. 4855.20 Launching Servicing Photoprint Book, OD 45738		April 1976	
NOTE: See last entry for applicable ORDALTs covered in this and previous developments.					
SYSKOM MRC CONTROL NO.	MAINTENANCE REQUIREMENT	PERIODICITY CODE	SKILL LEVEL	MAN HOURS	RELATED MAINTENANCE
75 DKYQ D	ASROC LAUNCHER HEATING AND COOLING SYSTEM 1. Check heating and/or cooling temperature and pressure systems. 2. Monitor heating and/or cooling system temperatures and record maximum cell temperature readings. 3. Monitor and record heating and/or cooling fluid inlet and outlet pressures and temperatures.	D-1	GMG/ GMTSN MM3	0.5 0.5	None
75 DKYR D	ASROC LAUNCHER MK 112 1. Perform operational checkout. NOTE: Perform this MR daily or as soon as conditions and time permit.	D-2R	GMG/ GMT3 GMG/ GMTSN	1.1 1.1	None
75 DKZS W	CARRIAGE MK 7 1. Clean and inspect cable drum covers and wiper seals; lubricate cable drum covers.	W-1	GMG/ GMT3 2GMG/ GMTSN	1.0 2.0	None
73 DFHK W	ASROC LAUNCHER MK 112 1. Compare train and elevation stow positions against recorded values in gunnery log book.	W-2	GMG/ GMT3 GMG/ GMTSN	0.3 0.3	None
75 DKZT W	CARRIAGE MK 7 1. Lubricate the three front carriage enclosure latch assemblies. 2. Lubricate ROTATE THROUGH STOP.	W-3	GMG/ GMT3 GMG/ GMTSN	0.7 0.7	None
46 DNDR W	ASROC LAUNCHER MK 112 1. Lubricate SAFE-FIRE switch handle assembly and padlock.	W-4	GMG/ GMT3 2GMG/ GMTSN	3.0 6.0	None

(Page 1 of 8)

SYSOM MRC CONTROL NO.	MAINTENANCE REQUIREMENT	PERIODICITY CODE	SKILL LEVEL	MAN HOURS	RELATED MAINTENANCE
46 DNDS W	STAND MK 107 1. Check training circle heater elements.	W-5	GMG/ GMT3	0.1	None
			2GMG/ GMTSN	0.2	
46 DNDU W	CARRIAGE MK 7 1. Test operation of train and elevation air drive motor.	W-6	GMG/ GMT3	0.5	None
			GMG/ GMTSN	0.5	
75 DKZY W	ASROC LAUNCHER HEATING AND COOLING SYSTEM 1. Test heating system thermostat operation.	W-7	GMG/ GMT3	0.6	D-1
			MM3	0.6	
75 DKZZ W	ASROC LAUNCHER MK 112 1. Test launcher temperature alarm system.	W-8	GMG/ GMT3	0.2	None
			GMG/ GMTSN	0.2	
75 DLAA W	CARRIAGE MK 7 1. Lubricate elevation stow latch linkages, stow latch pins, guide pin rollers, guide drive pin tracks, bell cranks, operating rods, and guide drive pin bushings. NOTE: Perform this MR whenever rail selected light window fails to function correctly, when misalignment is suspected, or once a week minimum. NOT USED	W-9R	GMG/ GMT3	1.4	None
			GMG/ GMTSN	1.4	
75 DLAB W	AC MK 53, RT MK 43, LCCP MK 199, ASROC LAUNCHER MK 112 1. Perform remote MEST, POWER-ON and POWER-OFF tests. **A management aid: Perform this MR on a different cell each week so that each cell is tested a minimum of once every 8 weeks.	W-11 **	GMG/ GMT1	1.0	None
			GMG/ GMT2	1.0	
			GMG/ GMT3	1.0	
			STG2	1.0	
			2STG3	2.0	
2STGSN	2.0				
75 DKYT M	CARRIAGE MK 7 1. Inspect hydraulic fluid levels of train and elevation sumps, and air lubricators. 2. Inspect air lubricators for proper operation.	M-1	GMG/ GMT3 2GMG/ GMTSN	1.0 2.0	None

(Page 2 of 8)

SYSKOM MRC CONTROL NO.	MAINTENANCE REQUIREMENT	PERIODICITY CODE	SKILL LEVEL	MAN HOURS	RELATED MAINTENANCE
75 DKYV M	CARRIAGE MK 7 1. Test elevation guide drive pin hydraulic pressure system.	M-2	GMG/ GMT3	0.3	M-5
			2GMG/ GMTSN	0.6	
46 DMZQ M	ASROC LAUNCHER MK 112 1. Test launcher performance. 2. Perform dynamic test on launcher using dummy director mode of operation.	M-3	GMG/ GMT3	3.8	None
			2GMG/ GMTSN	7.6	
75 DKYY M	ELEVATION POWER DRIVE MK 62 1. Test elevation free fall accumulator for proper nitrogen pressure charge.	M-4 **	GMG/ GMT3	0.7	M-7
			GMG/ GMTSN	0.7	
	**A management aid: This MRC is not applicable after accomplishment of ORDALT 7095, and if ASROC Launching Group Mk 16 Mod 4 and launchers Serial No. 257 and higher are installed.				
75 DKYZ M	CARRIAGE MK 7 1. Test guide drive pin accumulator 2A10-UAl for proper nitrogen charge.	M-5	GMG/ GMT3	0.4	M-2
			GMG/ GMTSN	0.3	
46 DMZS M	ASROC LAUNCHER MK 112 1. Test train stow and elevation tram positions.	M-6	GMG/ GMT3	1.0	W-2
			2GMG/ GMTSN	2.0	
△ 75 DKZD M	GUIDE MK 7 1. Inspect and lubricate forward cell doors, door hinges, and rail and door actuating mechanism. 2. Inspect door seals, oil levels, and nitrogen pressure of bottom snubbers. 3. Inspect aft (blast) covers and lubricate latch assemblies and all guide access doors.	M-7	GMG/ GMT3	3.2	None
			3GMG/ GMTSN	9.6	
75 DKZE M	GUIDE MK 7 1. Lubricate guide support bearings, torque tube support bearings, firing interrupter flexible cables, shafts, dogs of center access hatch, and both side doors.	M-8	GMG/ GMT3	0.7	None
			2GMG/ GMTSN	1.4	

(Page 3 of 8)

SYSOM MRC CONTROL NO.	MAINTENANCE REQUIREMENT	PERIODICITY CODE	SKILL LEVEL	MAN HOURS	RELATED MAINTENANCE
73 DFJC M	ASROC LAUNCHER MK 112 1. Lubricate launcher stand bearings and roller path.	M-9	GMG/ GMT3	0.3	None
			GMG/ GMTSN	0.3	
75 DLLV M	ASROC LAUNCHER HEATING AND COOLING SYSTEM 1. Test fluid freezing temperature. 2. Test fluid salinity. NOT USED	M-10	GMG/ GMT3	1.0	None
			BT3	1.0	
			2GMG/ GMTSN	2.0	
75 DKZJ M	ASROC LAUNCHER MK 112 1. Check train and elevation bench mark. NOTE: Perform this MR monthly, whenever cell is empty, after firing, or during yearly missile upkeep period.	M-12R	GMG/ GMT3	3.0	None
			2GMG/ GMTSN	6.0	
75 DKZK M	AC MK 38, RT MK 43, LCCP MK 199, ASROC LAUNCHER MK 112 1. Perform local MEST, POWER-ON, and POWER-OFF TESTS. **A management aid: Perform this MR on a different cell each month so that each cell is tested a minimum of once every 8 months.	M-13 **	GMG/ GMT1	1.0	None
			GMG/ GMT2	1.0	
			GMG/ GMT3	1.0	
			STG2	1.0	
			2STG3	2.0	
			STG3SN	1.0	
75 DLAF Q	CARRIAGE MK 7, ELEV POWER UNIT MK 62, TRAIN POWER UNIT MK 61 1. Lubricate train centering stow pin assembly. 2. Check fluid level of elevation depression buffer reservoir. 3. Check oil level in elevation power unit reduction gear housing. 4. Lubricate elevation air drive motor. 5. Check oil level in train power unit reduction gear housing. 6. Lubricate train air drive motor.	Q-1	GMG/ GMT3	1.1	None
			GMG/ GMTSN	1.1	
75 DMCQ A	STAND MK 107 1. Lubricate training circle and train drive pinion gear.	Q-2	GMG/ GMT3	1.0	None
			GMG/ GMTSN	1.0	

(Page 4 of 8)

SYSCOM MRC CONTROL NO.	MAINTENANCE REQUIREMENT	PERIODICITY CODE	SKILL LEVEL	MAN HOURS	RELATED MAINTENANCE
73 DFJJ Q	CARRIAGE MK 7 1. Lubricate elevation buffer arm bearing. 2. Inspect, clean, and lubricate elevation sector gear and drive pinion.	Q-3	GMG/ GMT3 GMG/ GMTSN	1.4 1.4	None
46 DNDX Q	ASROC LAUNCHER MK 112 1. Check fluid level in train buffers; clean and lubricate buffer pin and roller. 2. Clean and inspect launcher hydraulic and pneumatic lines and fittings. 3. Inspect heating and cooling hoses.	Q-4	GMG/ GMT3 GMG/ GMTSN	2.0 2.0	None
75 DLAH S	CARRIAGE MK 7 1. Lubricate elevation gearbox. 2. Lubricate elevation brake assembly. 3. Replace air filter 25 micron filter elements.	S-1	GMG/ GMT3 GMG/ GMTSN	2.0 2.0	S-2
A3 DGHX S	CARRIAGE MK 7 1. Lubricate train gearbox and train brake assembly.	S-2	GMG/ GMT3 GMG/ GMTSN	0.5 0.5	S-1
75 DLAJ S	CARRIAGE MK 7 1. Inspect hydraulic fluids in train and elevation power drive systems. **A management aid: Perform this MR after power drives have been secured for the preceding 12 hours.	S-3 **	GMG/ GMT3 GMG/ GMTSN	1.0 1.0	None
△ 75 DLAK S	GUIDE MK 7 1. Replenish hydraulic fluid and bleed entrapped air in bottom snubbers; charge cell accumulator with nitrogen, one each cell. NOTE: Perform this MR semi-annually or as directed by MRC M-7.	S-4R	GMG/ GMT3 3GMG/ GMTSN	3.5 10.5	M-7
46 DMZU	ASRCC LAUNCHER MK 112 1. Test launcher performance.	S-5	GMG/ GMT1 2GMG/ GMTSN	24.0 48.0	M-3

(Page 5 of 8)

SYSOM MRC CONTROL NO.	MAINTENANCE REQUIREMENT	PERIODICITY CODE	SKILL LEVEL	MAN HOURS	RELATED MAINTENANCE
75 DLAN S	<p>ASROC LAUNCHER MK 112</p> <p>1. Clean and inspect stand junction box 2A10.</p> <p>NOTE: Perform this MR semi-annually or after launcher has been exposed to heavy seas or inclement weather for prolonged period of time.</p> <p>**A management aid: On DDG-31 class, add 2 men, 2.0 M/H and tools as required for removal of boiler uptake protective cover. On DD-719 class add 0.5 M/H and tools as required for removal of exhaust vent.</p>	S-6R **	GMG/ GMT3 GMG/ GMTSN	1.5 1.5	None
75 DLAP A	<p>TRAIN RECEIVER REGULATOR MK 46</p> <p>1. Clean, inspect, and lubricate train receiver regulator internal gearing, shafting, and external response couplings and splines.</p>	A-1	GMG/ GMT3 GMG/ GMTSN	1.0 1.0	A-2
75 DLAQ A	<p>ELEVATION RECEIVER REGULATOR MK 47</p> <p>1. Clean, inspect, and lubricate elevation receiver regulator internal gearing, shafting, and external response couplings and splines.</p>	A-2	GMG/ GMT3 GMG/ GMTSN	1.0 1.0	A-1
△ 44 DHHC A	<p>ASROC LAUNCHER MK 112</p> <p>1. Clean, inspect, and lubricate interior of cell and working parts.</p> <p>NOTE: Perform this MRC after each firing; unfired empty cells shall be serviced once a year minimum and unfired loaded cells shall be unloaded annually for servicing.</p>	A-3R	GMG/ GMT3 2GMG/ GMTSN	8.0 16.0	None
75 DLAS A	<p>ASROC LAUNCHER MK 112</p> <p>1. Lubricate and inspect firing interrupter assembly.</p>	A-4	GMG/ GMT3 3GMG/ GMTSN	1.5 4.5	A-5

(Page 6 of 8)

SYS/COM MRC CONTROL NO.	MAINTENANCE REQUIREMENT	PERIODICITY CODE	SKILL LEVEL	MAN HOURS	RELATED MAINTENANCE
75 DLAT A	CARRIAGE MK 7 1. Lubricate train and elevation firing interrupter take-off gears.	A-5	GMG/ GMT3 GMG/ GMTSN	0.5 0.5	A-4 M-11
46 DNDV A	MISSILE SIMULATOR MK 6 1. Clean and inspect simulator. NOTE: Perform this MR annually or when corrective maintenance necessitates opening panels for repairs.	A-6R	GMG/ GMT2 GMG/ GMTSN	1.0 1.0	None
75 DLAU A	ASROC LAUNCHER MK 112 1. Clean and inspect interior of relay rack missile selector box 2A6. 2. Clean and inspect interior of relay rack rail selector box 2A7. NOTE: Perform this MR annually or after launcher has been exposed to heavy seas or inclement weather for prolonged period of time. NOT USED	A-7R A-8R	GMG/ GMT3 GMG/ GMTSN	2.5 2.5	None
75 DMCR A	ASROC LAUNCHER MK 112 1. Remove temperature sensing devices. 2. Test and calibrate the cell temperature sensing devices. NOTE: Perform these MRs when cells are empty.	A-9R	GMG/ GMT3 SN3	2.0 2.0	None
75 DLAW A	LCCP MK 199 1. Clean and inspect launcher captain's control panel.	A-10	GMT2 GMTSN	1.5 1.5	None
73 DFKA R	ASROC LAUNCHER MK 112 1. Perform pre-fire checkout. 2. Perform pre-fire launcher dynamic checkout. 3. Verify pre-fire SAFE-FIRE handle operation. NOTE: Perform this MR prior to firing.	R-1	GMG/ GMT1 ST3 GMG/ GMT2	0.6 0.6 0.6	None

(Page 7 of 8)

SYSTEM, SUBSYSTEM, OR COMPONENT Director, Dummy Mk 6 Mods 0 and 1		REFERENCE PUBLICATIONS OP 2809 OP 1303	DATE July 1975		
INFORMATION (THESE MAINTENANCE REQUIREMENTS ARE APPLICABLE TO EQUIPMENT IN WHICH THE FOLLOWING CHANGES HAVE BEEN ACCOMPLISHED): None					
SYSCON MRC CONTROL NO.	MAINTENANCE REQUIREMENT	PERIODICITY CODE	SKILL LEVEL	MAN HOURS	RELATED MAINTENANCE
<u>75</u> DLRD A	1. Clean, inspect, and lubricate dummy director.	A-1	GMT3	0.4	None
<u>75</u> DLRE A	1. Test dummy director operation.	A-2	GMT2	0.6	None
(Page 1 of 1)					

MRC TITLE	MRC NUMBER	RESPONSIBILITY		CURRENT STATUS		
		NAVSEA	DDEOC	OLD WITH NO CHANGE	OLD WITH REVISION	NEW
MRC J-16, M-7. "Inspect and lubricate forward cell doors.... Inspect door seals, oil levels, and nitrogen pressure of bottom snubbers..."	75 DKZD M		NUSC NEWPORT		X	
MRC J-16, S-4R. "Replenish hydraulic fluid and bleed entrapped air in bottom snubbers; charge cell accumulator with nitrogen..."	75 DLAK-S		NUSC NEWPORT		X	
MRC J-16, R-2. "Perform ASROC Launching System post-fire checks...."	75 DLAX R		NUSC NEWPORT		X	
MRC J-16, A-3R. "Clean, inspect, and lubricate interior of cell and working parts..."	44 DHHC A		NUSC NEWPORT		X	
MRC J-16, W-4. "Lubricate Safe/Fire Switch Handle and Padlock."	46 DNDR W		NUSC NEWPORT			X (Combined with other PMS Requirements)

* P = PERFORM MAINTENANCE; S = SURVEY INSPECTION

DDEOC MRC COMPARISON

CURRENT STATUS		MAN-HOURS		FREQUENCY		TYPE*	WHO PERFORMS TEST			WHERE PERFORMED
OLD WITH REVISION	NEW	PRE-DDEOC M/H	POST-DDEOC M/H	PRE-DDEOC	POST-DDEOC	P-PERF. S-SURV.	TENDER	DDEOC	SHIP	I-IN PORT S-AT SEA
X		12.8	12.8	M	M	P,S			X	I,S
X		14.0	14.0	S-4R	R	P			X	I,S
X		4.0	4.2 est.	R	R	P,S			X	I,S
X		24.0	24.2 est.	A-3R	A-3R	P,S			X	I,S
	X (Combined with other PMS Requirements)	9.0	2.0 est.	W	W	P			X	I,S

C	TYPE*	WHO PERFORMS TEST			WHERE PERFORMED	DATA	REMARKS
		TENDER	DDEOC	SHIP	I-IN PORT S-AT SEA	YES NO	
	P,S			X	I,S	No	Change sequence of procedure in accordance with paragraph 4.3.6.1. Make S-4R (recommended to be R-n) related maintenance.
	P			X	I,S	No	Periodicity change results in a decrease in hard time PMS burden of 28 MH per ship per year. Make M-7 related maintenance.
	P,S			X	I,S	No	Add procedure to inspect Launching Rail Cylinder for corrosion and leakage
	P,S			X	I,S	No	Add procedure to inspect Launching Rail Cylinder for corrosion and leakage
	P			X	I,S	No	Utilization of non-corrosive or an alternate set of security locks, performing lock preservation collectively and away from the launcher and combining the remaining handle lubrication procedure with other existing weekly PMS (such as W-1) will reduce PMS/ burden by an estimated 364 MH per ship per year.

APPENDIX C

PART-REPLACEMENT DATA

The printouts reproduced on the following pages tabulate the frequently used parts for Launching Group equipments.

APL 005020021

CLASS SUBSYSTEM SMA NO. SEQ. NO.-REV. SYS-SSDI

FF-1052 -721112 205

ASROC LAUNCHER

COMPONENT NOMENCLATURE - GUIDE, MK 7 MODS 1X2

APL QTY/SYS 4 SYS QTY/SHIP 1 SHIP POPULATION 46 SHIP OP. MOS. 1511.6

APL DATA QTY/ ON-RRD COMP ALLDM. REMARKS

NIIN	NOMENCLATURE	UNIT	QTY	SHIP POPULATION	SHIP OP. MOS.	ADDITIONAL IDENTIFICATION	NO. SHIPS REPORTED	TOTAL REPL	APL DATA QTY/ ON-RRD COMP ALLDM.	REMARKS
042321P	THERMOMETER	EA	16.50	EA	27	2245899	27	140	1	1
171R068	PACKING	EA	0.03	EA	15	AM6227-15	15	79	8	5
1864143	WASHER-NUTLIC	EA	1.00	EA	12	AM6246-15	12	288	16	26
2P14015	STUD ASSY	EA	0.21	EA	36	1788376	36	7104	48	20
4548340	SNIBBER, RTM, AFT	EA	2280.00	EA	7	1807540	7	26	2	0
4948343	SNIBBER, RTM, FWD	EA	2540.00	EA	3	1807541	3	18	2	0
5180846	SHITCM	EA	39.90	EA	9	1253742PC1	9	14	4	1
5233813	PING	EA	0.01	EA	29	1788524PC3	29	4877	48	16
6298921	NOOR	EA	204.00	EA	13	1815516	13	20	4	0
6737810	CYLINDER ASSY	EA	150.00	EA	7	2319708	7	13	2	0
6737945	PIN LOADIP	EA	15.50	EA	6	1788163	6	40	4	1
7756611	ROD ASSY	EA	376.00	EA	7	1656607	7	12	4	0
7756614	SLEEV	EA	105.00	EA	21	1656613	21	110	8	2
7756616	PIN (PISTON)	EA	38.00	EA	13	1656619	13	36	4	0
7758114	PIN (PISTON)	EA	27.50	EA	16	1656612	16	98	4	2
7765574	NOOR AFT R	EA	200.00	EA	8	1815712	8	14	2	0
7793677	COVER, FLEXIBLE	EA	52.00	EA	9	1806060-1656515	9	30	2	10

Replaced in conjunction with O/A 6151

APL 009020021

SYSTEM/SUBSYSTEM ASROC LAUNCHER
 CLASS FF-1052
 SUBSYSTEM SWBS 7211L2
 SEQ. NO.-REV. 205
 SMA NO. SYS-SSDI 7211

COMPONENT NOMENCLATURE - GUIDE, MK 7 MODS 1X2

APL QTY/SYS 4
 SYS QTY/SHIP 1
 SHIP POPULATION 46
 SHIP NP. MOS. 1511.6

NIIN	NOMENCLATURE	UNIT COST	UI	ADDITIONAL IDENTIFICATION	NO. SHIPS REPORTED	TOTAL REPL	APL DATA QTY/COMP	ON-ORD ALLOW.	REMARKS
8308700	PLNG	0.19	EA	1788800	17	103	8	3	
9685047	HANDLE	42.00	FA	1656707	10	29	2	1	
9784575	VALVE SOLE	257.00	FA	2319704	13	22	4	1	
9524870	SWITCH	42.78	FA	1676917	17	71	2	0	

C-4

BEST AVAILABLE COPY

API 005020017

SYSTEM/SUBSYSTEM ASROC LAUNCHER
 CLASS FF-1052
 SUBSYSTEM SWBS 7211-W1
 SEQ. NO.-REV. 205
 SMA NO. SYS-SSDI 7211

COMPONENT NOMENCLATURE - CARRIAGE MK7 MODS 2, 3, 4

API QTY/SYS 1 SYS QTY/SHIP 1 SHIP POPULATION 46 SHIP OP. MODS. 1511.6

NSN/PART NO.	NOMENCLATURE	UNIT COST	UT	ADDITIONAL IDENTIFICATION	NO. SHIPS REPORTED	TOTAL REPL	APL DATA		REMARKS
							QTY/COMP	UN-RPD ALLOW.	
5013099	RELAY, ROT.	173.00	EA	P/N 1704264PC3	9	10	3	2	Not listed in IPB
5186846	SWITCH	35.90	EA	P/N 1253742PCL	7	9	4	0	
5239472	CONNECTOR	14.50	EA	P/N 2256597	7	12	2	2	
5551824	FILTER	516.00	EA	P/N 1284137	7	8	1	1	
5836913	RELAY	43.40	EA		12	39	-	-	Not listed on any referenced APL
6049772	AIR MOTOR	955.00	EA	P/N 1655764-1	6	7	1	0	
6737788	ROCK	8.00	EA	P/N 1656021	28	120	4	4	
6737707	TRACK	64.00	EA	P/N 1807288	3	15	4	1	
6737748	SEAL ASSY	39.00	EA	P/N 1807369	10	65	8	2	
6737840	COUPLING	80.00	EA	P/N 1787768	8	10	1	0	
6737841	COUPLING	88.00	EA	P/N 1787743	6	6	1	0	
6737940	SUPPORT	165.00	EA	P/N 1815565	7	10	4	0	
6755920	AIR MOTOR	816.00	EA	P/N 1655764-2	17	21	1	0	
6759621	SWITCH	55.00	EA	P/N 1788141	8	11	2	1	
6772540	LUBRICATOR	76.00	EA	P/N 1807384	10	12	1	0	
6772541	LUBRICATOR	76.00	EA	P/N 1807383	6	10	1	0	
6829002	RELAY	153.00	EA	P/N 1788049	6	7	2	1	
7406863	PIN	0.62	EA	P/N 1788863PC2	26	435	12	1	
8487843	SCREW	0.11	EA	P/N 1221180-29	13	103	16	1	
8762176	HOUSING	87.00	EA	P/N 1787748	6	10	1	0	

APL 005020017

SYSTEM/SUBSYSTEM
ASROC LAUNCHER

CLASS FF-1052

SUBSYSTEM SWBS 7211-WI

SEQ. NO.-REV. 205

SMA NO. SYS-SSDI 7211

COMPONENT NOMENCLATURE - CARRIAGE MK7 MODS 2, 3, 4

APL QTY/SYS 1

SHIP POPULATION 46

SHIP CP. MOS. 1511.6

MSN/PART NO.	NOMENCLATURE	UNIT COST	U/I	ADDITIONAL IDENTIFICATION	NO. SHIPS REPORTED	TOTAL REPL	APL DATA QTY/ ON-BRD COMP ALLOW.	REMARKS
9525434	HCSE ASSY	31.13	EA	P/N MS28741-16-2030	14	50	6	Ø
8887526	P/N ASSY	386.00	EA	P/N 1676875	9	13	4	1
9134762	HOUSING CONDUIT ASSY	85.00	EA	P/N 1787769	7	7	1	Ø
9784575	SOL VALVE ASSY	257.00	EA	P/N 2319704	11	17	4	Ø
9893436	HCSE	27.10	EA	P/N MS28741-16-2300	14	42	2	Ø
9918937	ELEMENT	31.80	EA	P/N 1778749REVH	8	23	1	1
9024469	WINDOW	6.20	EA	P/N 1656110	13	34	2	Ø

Ø - Removed by O/A 7695-
Not Analyzed

AD-A052 164

ARINC RESEARCH CORP ANNAPOLIS MD
DESTROYER ENGINEERED OPERATING CYCLE (DDEOC) SYSTEM MAINTENANCE--ETC(U)
OCT 76

F/G 19/7

N00024-76-C-4319

UNCLASSIFIED

1645-50-4-1550

NL

2 OF 2
ADA
052164



END
DATE
FILMED
5 -78
DDC

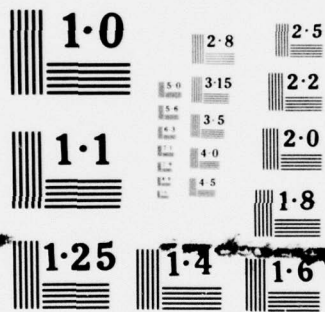

NATIONAL BUREAU OF STANDARDS
MICROCOPY RESOLUTION TEST CHART

APL 005020013

SYSTEM/SUBSYSTEM
ASROC LAUNCHING GROUP

CLASS FF -1052
SUBSYSTEM SMRS
7211PJ
7211L5
SEQ. NO.-REV. 205
SMA NO. SYS-SSDI
7211

COMPONENT NOMENCLATURE - PANEL, LAUNCHER CAPTAIN'S CONTROL MK 199, MOD/S 3X4X5

APL QTY/SYS 1 SHIP POPULATION 46 SHIP OP. MUS. 1511.6

1

NSN/PART NO.	NOMENCLATURE	UNIT CLST	UT	ADDITIONAL IDENTIFICATION	NO. SHIPS REPORTED	TOTAL REPL	APL DATA QTY/ ON-RRD COMP ALLOW.	REMARKS
1557836	LAMP	C.21	FA	P/N MS25237-327	20	524	134 6	Indicator lights- not analyzed Not listed on APL Not listed on APL
5030383	SYN	5C.0C	FA		5	6		
5836913	PFLAY	27.10	EA		11	34		
6603822	WFLAY	26.80	EA	P/N 1676520	12	17	6 1	
6603823	WFLAY	4F.5C	EA	P/N 1676519	18	23	2 1	
673063	PLUG	42.50	FA	P/N 1788210	11	12	1 2	
6773931	REFLAY	9C.0C	FA	P/N 148760	25	36	4 1	
8586743	AMPLIFIER	113C.00	FA	P/N 1877413	14	20	2 1	

C-8

BEST AVAILABLE COPY

APL 005020022

SYSTEM/SUBSYSTEM CLASS SUBSYSTEM SEQ. NO.-REV. SMA NO. SYSDI
ASROC LAUNCHING GROUP FF-1052 4832TS 205 7211

COMPONENT NOMENCLATURE - TEST SET, ELECTRICAL SYSTEM, MISSILE, MK 363 MOD'S 1X3

APL QTY/SYS SYS QTY/SHIP SHIP POPULATION SHIP GP. MCS. SHIP ID
1 1 46 1511.6

NIIN	NOMENCLATURE	UNIT COST	UI	ADDITIONAL IDENTIFICATION	NO. SHIPS REPORTED	TOTAL REPL	APL DATA QTY/ ON-BRD COMP ALLOW.	REMARKS
85R3672	CABLE	173.00	FA	P/N 1453482	12	13	1 1	

BEST AVAILABLE COPY

A. I. 005020014

CLASS SUBSYSTEM SMA NO. SYS-SSDI
 FF-1052 5832SM 205 7211

SYSTEM/SUBSYSTEM
 ASROC LAUNCHING GROUP

COMPONENT NOMENCLATURE - SIMULATOR, MK 6, MOD 2

APL JTY/SYS SYS CTY/SHIP SHIP POPULATION SHIP OP. MDS.
 1 1 46 1511.6

NIIN	NOMENCLATURE	UNIT COST	UI	ADDITIONAL IDENTIFICATION	NO. SHIPS REPORTED	TOTAL REPL	APL DATA QTY/ ON-ORD COMP ALLOW.	REMARKS
5826913	RELAY	27.10	FA		7	39		
3704101	SWITCH	117.00	FA	P/N 1453294	6	R	1 0	Not listed on APL

APPENDIX D

CASREPT SUMMARY

One-hundred thirty-six Casualty Reports (CASREPTs) reported against the ASROC Launching Group during the period 1 January 1970 through 30 December 1974 were reviewed in depth. A listing of CASREPTs by component and failure mode follows:

1. GUIDE, MK 7, TOTAL CASREPTS: 37 (27 PERCENT OF TOTAL)

Reported Component Failure Modes:

<u>Component</u>	<u>Failure Mode</u>	<u>Number of Reports</u>
Rail/Cylinder ↓	Binding causing ruptured air cylinder	1
	Unable to extend or retract -- faulty solenoid	1
	Defective floating blocks in retaining latch	1
	Broken brace on rail assembly	1
Safe-Fire Handle ↓	Open electrical leads	1
	Arming actuator mechanism failed	1
	Rotating switch inoperable	1
	Safe-fire handle will not make switch in missile-connector junction box	1
	Replaced safe-fire handle	1

<u>Component</u>	<u>Failure Mode</u>	<u>Number of Reports</u>
Bottom Snubber ↓	Frozen	3
	Scored snubber pistons/sleeves	6
	Inoperative; will not release	4
	Unable to rely on operation	1
	Malfunction in snubber unable to launch	1
	Pins scored to aft snubber -- unable to launch from Cell 7	1
	Eye broken due to binding	1
	Right pin of aft snubber frozen to sleeve	1
Side Snubbers	Will not extend -- defective	1
Missile-to-Launcher	Connector in Cells 1 and 2 cracked during firing at AFWR	1
None ↓	Guides will not elevate	2
	Unable to clear or select guide	1
	Experienced problems in two distinct areas	1
	Firing circuit interrupted	1
	Unsafe for loading due to misalignment	1
	Heat exchanger ruptured	1
	Unable to launch weapons due to wiring error	1

2. CARRIAGE, MK 7, TOTAL CASREPTS: 66 (49 PERCENT OF TOTAL)

Reported Component Failure Modes:

<u>Component</u>	<u>Failure Mode</u>	<u>Number of Reports</u>
Guide Drive Pin (GDP) and Associated Parts ↓	Misalignment of guide drive pin and track/support	4
	Guide drive pin bound/scored/corroded	9
	Sheared track	10
	Stiffener cracked due to GDP binding	3
	Broken GDP mounting base	2
	Ram for Guide 4 scored	1
	Cylinder recycles fluid	1
Heating/Cooling Hoses	Sheared due to sea water rotting	1
	Hoses ruptured due to deterioration	3
Pneumatic Hose	300-psi hose corroded; separated from casings	2
Pneumatic Reducer	Malfunctioning - unable to move launcher safely; will not hold 300-psi due to defective push rod	2
Rail Selector Relay Rack ↓	Rail selector switch inoperative due to corrosion	1
	Wires deteriorated to 2A7 connector box	1
Elevation Air Drive Motor ↓	Inoperative air drive motor due to internal corrosion	2
	Air motor inoperative -- no grease fittings	1
	Air motor leaks	1
	Defective tilt-pin alignment switch	1

<u>Component</u>	<u>Failure Mode</u>	<u>Number of Reports</u>
General ↓	Unable to train launcher with hydraulic system due to salt water exposure	1
	Unable to program ASROC RTDCs reliably	1
	No reload capability and unable to perform MEST tests	1
	Malfunction of firing circuit -- cause unknown	1
	Unable to fire ASROC	1
	Transferred track support to USS REASONER	1
	Cannot elevate launcher due to storm damage	1
	Loss of launcher train in remote local	1
Firing Interrupter ↓	18 minutes over safe allowable error in train non-firing area	1
	Flexible cable parted -- interior cable kinked	1
	Coupling from train drive to FCO broken	1
Valves	Check and dump valves will not hold to scored valve seat	2
Elevation Drive Gear	Corrosion to oil seal prevents loading/unloading	1
Train Drive Gear	Loud rumbling sound in reduction gears -- part failure	1
Stow Latches	Sheared by wave loading	1
Torque Tube ↓	Corroded guide bearings -- lubricant hardened	1
	Torque tube support bearing seized	1

<u>Component</u>	<u>Failure Mode</u>	<u>Number of Reports</u>
Elevation Brake	Slipping -- unable to match LCCP	1
↓	Leaks oil	1
Train Brake	Fails to disengage properly	1

3. LCCP MK 199, TOTAL CASREPTS: 17 (12 PERCENT OF TOTAL)

Reported Component Failure Modes:

<u>Component</u>	<u>Failure Mode</u>	<u>Number of Reports</u>
Power Drive Amplifier ↓	Power drive amplifier shorted	1
	T10 transformer burned out due to 400-Hz ground	1
	Elevation amplifier defective	1
	Unable to obtain elevation synchronization	2
	Open circuit in amplifier	2
	Elevation amplifier malfunctioning, causing guides to depress only	1
Transformer 2A7T1	Does not produce proper voltage	1
Relay 3A2A5K1	Failed -- unable to train launcher	1
Hold Relay K-17	Failed -- unable to select guides	1
40-Vdc Dud Indicator	Lost due to shorted DR 43, 44; open CR 45 and 46	1
Fuses F21 and F22	Blow when S-10 is depressed	1
None ↓	Defective relay -- launcher power drives will not train or elevate launcher	1
	Unable to stabilize launcher train in remote	1
	Problem in interface between LCCP and launcher	1
	Unable to obtain missile-ready indication	1

4. POWER DRIVES, ELEVATION MK 62 AND TRAIN MK 61, TOTAL CASREPTS: 12
(9 PERCENT OF TOTAL)

Reported Component Failure Modes:

<u>Component</u>	<u>Failure Modes</u>	<u>Number of Reports</u>
Hydraulics ↓	Excessive leaking in lines	1
	Broken piston rod	1
	Corroded pistons	1
Servo Valve	Malfunctioning, causing launcher to run away in train	1
Stroke Control Valve	Connector plug deteriorated	1
Gears	Helical gears in elevation drive misaligned and overheated	1
Elevation Motor ↓	Noisy bearings -- worn seal or main bearing	1
	Bearings frozen and cylinder surfaces worn	1
Coupling	Coupling between train power drive and receiver regulator sheared	1
None ↓	Unable to load/unload due to corrosion	1
	Train power drive has excessive vibration/noise	1
	Loss of train and elevation power drives due to saturation from sea water	1

5. SIMULATOR, MK 6, TOTAL CASREPTS: 3 (2 PERCENT OF TOTAL)

Reported Component Failure Modes:

<u>Component</u>	<u>Failure Mode</u>	<u>Number of Reports</u>
None	Shorted transformer	2
↓	Unable to obtain missile-ready indication	1

6. DUMMY DIRECTOR, MK 6 MOD 1, TOTAL CASREPTS: 1 (1 PERCENT OF TOTAL)

Reported Component Failure Modes:

<u>Component</u>	<u>Failure Mode</u>	<u>Number of Reports</u>
Harmonic Motion Synchro	Inoperable	1

APPENDIX E

LAUNCHING GROUP ORDALTS

Table E-1 lists the ASROC Launching Group Ordnance Alterations.

Table E-1. ASROC LAUNCHER ORDALTS

ORDALT Number	FMP Group ID Number	Short Description	Estimated Kit Cost (Dollars)	Estimated Kit Availability	Estimated Man-Hours
6451* Chg. 1	W4315	Full-Power Ram Change 1, Floating Block Mod	5000	6/72 8/73	360
7683*	W4315	Elevation Receiver Regulator Digital-Dial Alignment-Guarantee Change, Direct Loader Interface	70	12/77	30
8455*	W4315	Direct Loader Safety (Train Air Drive Interlock and Over-Ram)	750	12/74	48
8671*	W4315	Direct Loader Safety (Fail-Safe Solenoid Valve)	1000	6/76	50
6803	W2230	Launcher Corrosion/Water Tightness Improvement	3000	12/71	250
7488	W2230	Launcher Air Filters	300	2/73	80
7695	W2230	Carriage Enclosure	10,000	7/73	144
8613	W2230	Cell Door Gaskets	500	1/76	18
8670	W2230	Guide Drive Pin	6000	12/76	250
8672	W2230	Snubber Mod	6400	3/77	250
Pending	W2230	Power Drive Amplifier	6000	9/77	4
8178	W2210	HERO/Missile	60	7/73	8
8179	W2210	HERO/MEST Set (Branch Cable)	700	7/73	8
8180	W2210	HERO/Launcher J-Box	1600	7/73	80
7934	W2200	Torpedo Mk 46 Ident Launch Group Mk 16/4, 5, 6	10	4/72	40
8387	W2200	Torpedo Mk 46 Ident MEST Set	10	10/73	4
8896	W8000	Harpoon Mod to ASROC Launcher Group Mk 16	85,000	4/76	960

*These ORDALTs pertain to the Launcher/Loader interface and require concurrent SHIPALTs FF-1052-030K, FF-1092-037K, and FF-1052-259K. These will be discussed in the ASROC Loading/Handling Equipment SMA.

APPENDIX F

MACHINERY INSPECTIONS AND MAJOR OVERHAULS

Table F-1 lists the applicable ship, date, score, and major-overhaul decision for 23 FF-1052 Class Machinery Inspections. A chronological graph of Navy-wide major overhauls is presented as Figure F-1. The discrepancies noted in the 23 FF-1052 Class Machinery Inspections are summarized on the remaining pages.

Table F-1. RESULTS OF FF-1052 CLASS ASROC
MACHINERY INSPECTIONS

Ship	Inspection Date	Score	Class "A" Overhaul
FF-1052	3/72	217	No
FF-1052	10/75	173	Yes
FF-1053	1/74	148	Class "B" - Long Beach
FF-1054	3/74	154	Class "B" - Long Beach
FF-1055	1/73	112	Yes
FF-1055	11/75	181	No
FF-1056	2/72	178	No
FF-1057	3/73	155	Yes
FF-1058	9/73	181	No
FF-1059	8/74	180	Yes
FF-1060	3/73	88	Yes
FF-1062	2/75	*	Yes
FF-1063	8/75	186	No
FF-1064	7/74	194	No
FF-1065	6/75	174	Yes
FF-1066	3/74	211	No
FF-1068	9/75	185	No
FF-1071	8/74	181	No
FF-1072	4/73	203	No
FF-1074	6/74	188	No
FF-1075	9/75	205	No
FF-1076	8/75	184	No
FF-1077	*	*	Yes

*Data not available.

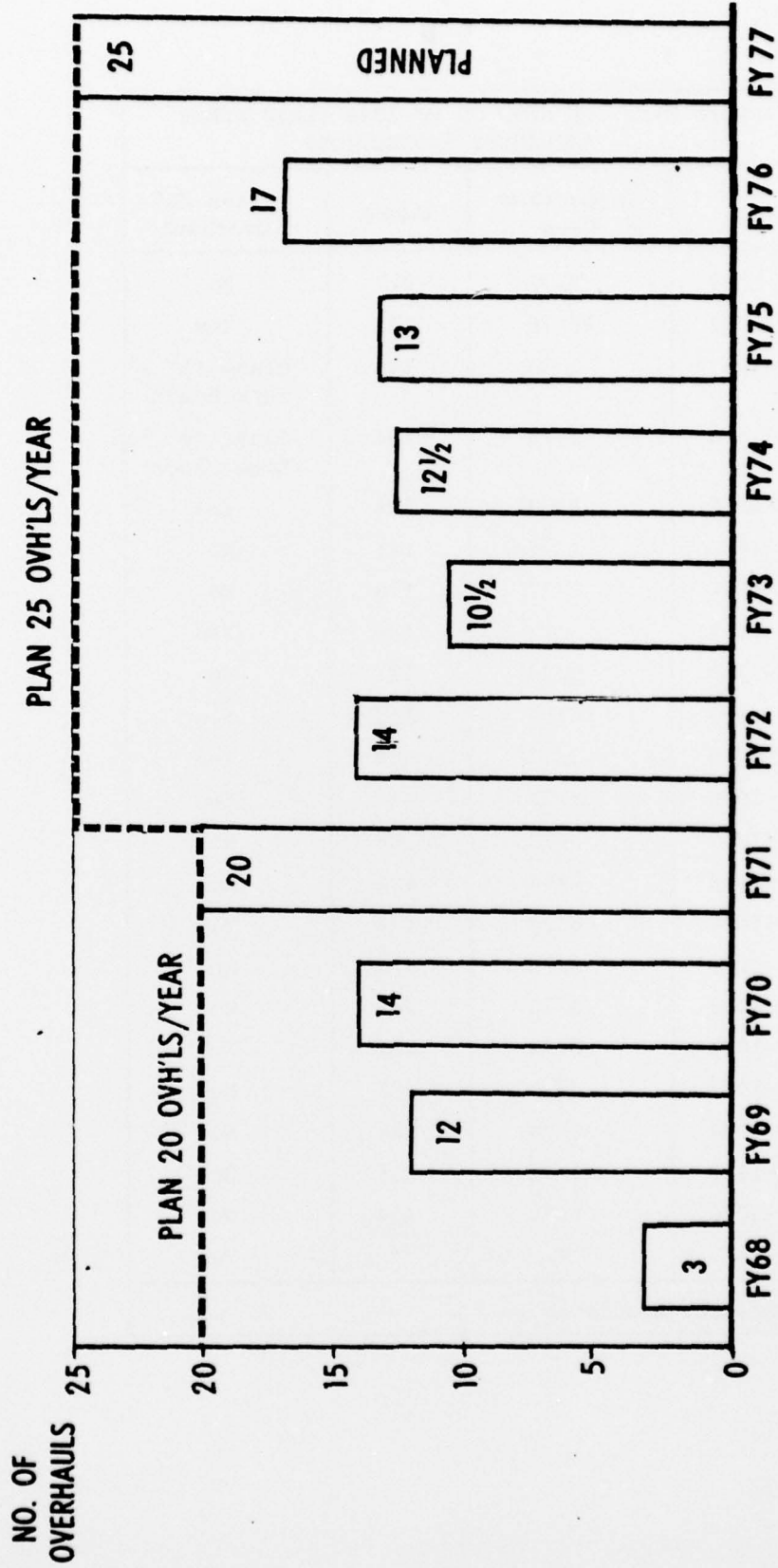

*Extracted from October 1975 DART Progress Report.

Figure F-1. MAJOR OVERHAULS ACCOMPLISHED: ASROC LAUNCHER*

<u>SHIP</u>	<u>INSP. DATE</u>	<u>SCORE</u>
FF 1052	3/72	217
Discrepancies: Train and elevation sump valve corroded.		
Guide 2 side wiper seals torn.		
All guide cable drumcover screws rusted.		
Door gaskets torn.		
Elevation drive hydraulic line leak between pump and drain.		
FF 1052	10/75	173
Discrepancies: Aft shear panel #1.		
Central torque tube bearing cap corroded.		
Train stow pin well rusted.		
Port torque tube inspection cover corroded.		
Cell #4 doors don't close.		
Elevation air drive motor slow and erratic.		
Excessive lost motion in train gearing.		
Heating and cooling hoses deteriorated.		
Carriage cablewell very corroded.		
All pipe fittings corroded (piping is non-corrosive).		
Elevation firing interrupter flexible cable rusty.		
Guide support beam corroded.		
Elevation brake slips.		
Slight corrosion in all cells.		
FF 1053	1/74	148
Discrepancies: All guide drive pins misaligned.		
Train and elevation power drive B end adapter plates corroded.		
80% of piping extensively corroded.		
Replace all heating and cooling hoses.		
Carriage - excessive rust and corrosion.		
Corrosion on all sub cell components.		
Snubbers operate erratically in all cells.		
Doors on cells 1, 3, 5, 6, 8 will not fully close.		
Right access panel guide #2 - excessively corroded.		

<u>SHIP</u>	<u>INSP. DATE</u>	<u>SCORE</u>
FF 1054	3/74	154
Discrepancies: Heating and cooling hoses deteriorated.		
Rust extensive in stand.		
Firing interrupter flexible cables, severely damaged by corrosion.		
Carriage "B" end plate severely corroded.		
Cell 6 - doors binding - rail latch cylinder seized.		
Cell 7 - rail cylinder frozen; rail severely rusted.		
Rails and snubbers in all cells out of timing specs.		
Cable drum wipers rubbing on cable drum covers.		
FF 1055	1/73	112
Discrepancies: All electrical connectors severely corroded.		
Corrosion excessive on carriage floor and all cells.		
Train and elevation air motors severely corroded.		
Guide drive pins and stow latches binding on all guides.		
Air lubricators inoperative.		
Snubber cylinder scored in cell 7 & 8.		
Excessive error in train and elevation amplifiers.		
Firing interrupter cable damaged.		
FF 1055	11/75	181
Discrepancies: Guides 3 and 4 exterior panels patched in 1973 are deteriorated.		
. Replace guides 3 and 4.		
LP air lubricator is defective.		
Base ring (calrod) heater missing.		
Audible air leak in cell 5 with snubbers extended.		
Guide 2 supporting bracket has minor corrosion.		
Elevation buffer has minor corrosion.		
FF 1056	2/72	178
Discrepancies: Snubbers inoperative in 4 of 8 cells.		
Floors of all cells damaged by corrosion.		
Carriage enclosures damaged; interior excessively rusted.		
Drum cover wipers torn.		
Electrical connectors in all cells corroded.		
Elevation air motor defective.		
Train and elevation power drive amps. out of adjustment.		

<u>SHIP</u>	<u>INSP. DATE</u>	<u>SCORE</u>
FF 1059	8/74	180
Discrepancies: 300 PSI hose deteriorated.		
Cable drum wiper brackets corroded.		
Carriage excessively corroded.		
Torque tube bearing caps and bolts severely corroded.		
Elevation reduction gear box corroded.		
FF 1060	3/73	88
Discrepancies: All connectors on stand, carriage and guides corroded.		
Excessive corrosion on carriage floor and all major components in all cells.		
Electrical connectors heavily corroded.		
Guide drive pin and stow latches binding and misaligned.		
Excessive rust in train and elevation air motors.		
Train and elevation amplifiers damaged due to short circuit.		
Aft support "C" beam damaged and requires replacement.		
FF 1063	8/75	186
Discrepancies: Heating and cooling hoses deteriorated.		
Electrical connectors severely corroded.		
Lenz connectors and hydraulic fittings corroded.		
Forward cable drum wiper seals need to be replaced.		
Elevation power drive brake slips.		
Forward bottom snubber in cell 4 seized.		
Aft shear panel supporting beam bent in vicinity of guide drive pin 1.		
Extensive surface corrosion on decks of all cells.		
FF 1064	7/74	194
Discrepancies: Heating and cooling hoses deteriorated.		
Elevation "B" end adaptor plate corroded.		
#1 guide stow latch frozen - all stick		
Elevation brake slipping.		
Aft stiffener sprung and misaligned.		
All stow latch boots damaged.		
All guide pins frozen.		

<u>SHIP</u>	<u>INSP. DATE</u>	<u>SCORE</u>
FF 1065	6/75	174
Discrepancies: Heating and cooling hoses deteriorated.		
Lenz connectors excessively corroded.		
Severe rust in carriage deck area and sub assembly (power drives, gear boxes, valves, etc.).		
Elevation firing interrupter flex cable rusted.		
Corrosion on electrical connectors in all cells.		
All guide drive pins misaligned; all switches out of adjustment.		
Hydraulic oil train and elevation drives contaminated.		
Guide 4 moves side to side.		
Aft carriage shear panel damaged.		
Guide decks - all sub assemblies to be removed and guide decks refurbished.		
FF 1066	3/74	211
Discrepancies: Heating and cooling hoses deteriorated.		
Guide drive pin #4 misaligned.		
FF 1068	9/75	185
Discrepancies: Guide drive pin sleeves in guides #1 and 4 slipping; lubricator fittings broken.		
All guide drive pin cylinders and linkages out of adjustment.		
All electrical connectors to power drives deteriorated.		
Heating and cooling hoses deteriorated.		
FF 1071	8/74	181
Discrepancies: S/F handles rusted.		
Firing interrupter cable stretched and rusted.		
Wiper brackets corroded.		
Heating and cooling hoses deteriorated.		
#3 guide drive pin scored.		
Guide drive pin position switch actuator rollers frozen.		
Guide operating rod end and latch arm balljoints rusted.		
Hydraulic fittings rusted.		
Bench mark plate missing.		
Hydraulic indicator leaks in cells #2 and 5.		

<u>SHIP</u>	<u>INSP. DATE</u>	<u>SCORE</u>
FF 1072	4/73	203
Discrepancies: Numerous steel piping and fittings rusted.		
Hydraulic pump 2A10-UP1 leaks excessively.		
Electrical connectors on stroke control units and filter units eteriorated.		
Guide drive pin movements rough - check alignment.		
Left hand wiper on back of launcher damaged.		
Cable and hose loop support missing.		
FF 1074	6/74	188
Discrepancies: Guide wiper seal brackets corroded.		
Hydraulic pipe fittings corroded.		
Stow latch ball joints and protective boots torn.		
Firing interrupter flex cables rusted.		
All guide drive pins scored.		
Elevation "B" end adaptor plate corroded.		
Heating and cooling hoses deteriorated.		
Stow latch roller mount corroded.		
Train gear excessive backlash.		
#2 bottom snubber binding.		
Hydraulic indicators need recharging in all cells.		
Ineffective air motor.		
FF 1075	9/75	205
Discrepancies: Heating and cooling manifolds rusty.		
80% of steel tubing in carriage rusty.		
Excessive rust in stand and carriage.		
Aft shear plate stiffener deteriorated.		
Corrosion on cell decks and restraining latch cylinder.		
Heating and cooling hoses deteriorated.		
All electrical cables excessively painted.		
Accumulator dump valve not operating freely.		

<u>SHIP</u>	<u>INSP. DATE</u>	<u>SCORE</u>
FF 1076	8/75	184

Discrepancies: Elevation brake slips.
Train and elevation power amplifiers need alignment.
Guide drive pins need alignment.
Elevation buffer piston stuck.

APPENDIX G

COMPUTATION OF ASROC GMT (0891) PMS MAN-HOUR BURDEN

The below-listed MIPs were utilized in ascertaining the weekly PMS man-hour burden of the ASROC Gunner's Mates (GMT-0891):

System/Title	MIP Number
Launching Group, Mk 16, Mod 5	J-16/5-46
Launching Group, Mk 16, Mod 6	J-16/6/46
ASROC Loading System	WS-8/16-94
Magazine Sprinkling System	A-637/P3-65
FGC, ASROC, Mk 114	J-114/13-75
Dummy Director, Mk 6, Mod 1	J-ORD 2/1-75
Recorder, Error, Mk 12, Mod 1	J-ORD 3/1-45
Handling-Equipment Weight Test	WS-95/3-16
Explosive Ordnance Safety Inspection	
ASROC Magazine	X-2/1-46
Sling, Missile Container, Mk 75, Mod 0	8-165/1-C1
Truck, Hand Life, Mk 42, Mods 1 and 2	8-175/1-75

These MIPs were screened for all PMS actions requiring Gunner's Mate man-hour expenditures. Table G-1 presents these man-hours for each MIP summed at the periodicity level. These sums were converted to a total weekly burden (B,w) by the following formula:

$$\begin{aligned}
 B_w = & \sum_{i=1}^{10} 5M_{di} + \sum_{i=1}^{10} M_{wi} + \sum_{i=1}^{10} \frac{M_{mi}}{4.33} + \sum_{i=1}^{10} \frac{M_{qi}}{13.00} + \sum_{i=1}^{10} \frac{M_{si}}{26} + \sum_{i=1}^{10} \frac{M_{ai}}{52} \\
 & + \sum_{i=1}^{10} \frac{M_{ci}}{260} + \sum_{i=1}^{10} \frac{M_{ri}}{52}
 \end{aligned}$$

Table G-1. ASROC GUNNER'S MATE PMS BURDEN

MIP	Periodicity							
	Daily	Weekly	Monthly	Quarterly	Semi-Annual	Annual	Cyclical*	Situational (R)**
J-16/5-46 or J-16/6-46	2.7	22.1	49.5	11.0	96.0	49.0	0	6.4
WS-8/16-94	0	5.4	3.0	5.0	3.0	3.0	0	0
A-637/P3-65	0	0.5	1.2	2.4	0	8.0	24.0	7.2
J-114/13-75	0.4	0.2	1.8	0	0	1.0	0	0
J-ORD2/1-75	0	0	0	0	0	1.0	0	0
J-ORD3/1-45	0	0	0	0	0.7	0.5	0	0
WS-95/3-16	0	0	0	12.0	0	0	0	0
X-2/1-46	1.4	1.0	1.0	2.7	0.2	0	0	0.2
8-165/1-C1	0	0	0	0.3	0	0	0	0.4
8-175/1-75	0	0	0	1.4	0	0	0.6	0.8
Totals	4.5	29.2	56.5	34.8	99.9	62.5	24.6	15.0

*Man-hours based on 60-month cycle.
 **Man-hours for situational requirements based on engineering estimates of these occurrences on an annual basis.

where

- i = individual MIPs
- M_{di} = daily man-hours for the i^{th} MIP
- M_{wi} = weekly man-hours for the i^{th} MIP
- M_{mi} = monthly man-hours for the i^{th} MIP
- M_{qi} = quarterly man-hours for the i^{th} MIP
- M_{si} = semiannual man-hours for the i^{th} MIP
- M_{ai} = annual man-hours for the i^{th} MIP
- M_{ci} = cyclical man-hours for the i^{th} MIP
- M_{ri} = situational (R) man-hours for the i^{th} MIP

When the burden figures from Table H-1 are substituted, the formula becomes

$$B_w = 4.5(5) + 29.2 + \frac{56.5}{4.33} + \frac{34.8}{13.00} + \frac{99.9}{26} + \frac{62.5}{52} + \frac{24.6}{260} + \frac{15.0}{52} = 72.85$$

REPORT DOCUMENTATION PAGE		READ INSTRUCTIONS BEFORE COMPLETING FORM
1. REPORT NUMBER 1645-50-4-1550 ^v	2. GOVT ACCESSION NO.	3. RECIPIENT'S CATALOG NUMBER
4. TITLE (and Subtitle) DESTROYER ENGINEERED OPERATING CYCLE (DDEOC) SYSTEM MAINTENANCE ANALYSIS FF-1052 CLASS ASROC LAUNCHING GROUP	5. TYPE OF REPORT & PERIOD COVERED	
	6. PERFORMING ORG. REPORT NUMBER 1645-50-4-1550	
7. AUTHOR(s) NOT LISTED	8. CONTRACT OR GRANT NUMBER(s) N00024-76-C-4319 ^v	
9. PERFORMING ORGANIZATION NAME AND ADDRESS ARINC Research Corp. 2551 Riva Road Annapolis, Maryland 21401	10. PROGRAM ELEMENT, PROJECT, TASK AREA & WORK UNIT NUMBERS	
11. CONTROLLING OFFICE NAME AND ADDRESS Director, Escort and Cruiser Ship Logistic Division Naval Sea Systems Command	12. REPORT DATE October 1976	
	13. NUMBER OF PAGES 65	
14. MONITORING AGENCY NAME & ADDRESS (if different from Controlling Office) Director, Escort and Cruiser Ship Logistic Division Naval Sea Systems Command	15. SECURITY CLASS. (of this report) UNCLASSIFIED	
	15a. DECLASSIFICATION/DOWNGRADING SCHEDULE	
16. DISTRIBUTION STATEMENT (of this Report) UNCLASSIFIED/UNLIMITED		
17. DISTRIBUTION STATEMENT (of the abstract entered in Block 20, if different from Report)		
18. SUPPLEMENTARY NOTES		
19. KEY WORDS (Continue on reverse side if necessary and identify by block number)		
20. ABSTRACT (Continue on reverse side if necessary and identify by block number) The System Maintenance Analysis Report for the ASROC Launching Group consists of a single volume, the Review of Experience. It presents a review of the maintenance experience for the Launching Group, an analysis of the problems encountered and anticipated, and recommendations for actions required to achieve the Launching Group DDEOC goal of improved material condition at an acceptable cost, while maintaining or increasing operational availability during an extended operating cycle.		