

AD-A052 342

NAVAL OCEAN SYSTEMS CENTER SAN DIEGO CA
PERSPECTIVE RADAR DISPLAY SYSTEM. TV-LIKE PRESENTATION ON CRT P--ETC(U)

F/G 14/2

JAN 78 L 6 HARRIS

UNCLASSIFIED

NOSC/TR-198

NL

| OF |

AD
A052342



END
DATE
FILMED
5 -78
DDC

①

B.S.

NOSC

NOSC TR 198

Technical Report 198

PERSPECTIVE RADAR DISPLAY SYSTEM

TV-like Presentation on CRT Provides Higher Lateral Position and Lateral Motion Sensitivity Than a PPI

LG Harris

17 January 1978

Evaluation: March — December 1977

Prepared For

Naval Sea Systems Command (PMS 300)

DDC

RECEIVED
APR 7 1978
RECEIVED

B

Approved for public release; distribution unlimited.

NAVAL OCEAN SYSTEMS CENTER
SAN DIEGO, CALIFORNIA 92152

AD A 052342

AD No.
DDC FILE COPY



NAVAL OCEAN SYSTEMS CENTER, SAN DIEGO, CA 92152

AN ACTIVITY OF THE NAVAL MATERIAL COMMAND

RR GAVAZZI, CAPT, USN

Commander

HL BLOOD

Technical Director

ADMINISTRATIVE INFORMATION

Technical and operational evaluation work was performed under NOSC Work Unit CC21827B10 (N422720) by the Naval Ocean Systems Center Man-Systems Interaction Division (Code 823) in response to requirements of the Naval Sea Systems Command (PMS 300) Combatant Craft Improvement Program under PMS 300 Work Request N0002477P078386, Program Element 63516N, Project S0181-AA, Task Area S0181. The evaluation was conducted under the NOSC management of WE Milroy and J Marez. The report covers work from March to December 1977. The author acknowledges the contributions of LTJG Rick Lovering and the crew of PB 751 from Coastal River Squadron One, Amphibious Base, Coronado, California, for their cooperation and assistance throughout the test period.

Released by
JJ Silva, Head
Man-Systems Interaction Division

Under authority of
JH Maynard, Head
Command Control – Electronic
Warfare Systems and Technology
Department

UNCLASSIFIED

SECURITY CLASSIFICATION OF THIS PAGE (When Data Entered)

14 / NO SC/TR-198

REPORT DOCUMENTATION PAGE		READ INSTRUCTIONS BEFORE COMPLETING FORM
1. REPORT NUMBER NOSC Technical Report 198 (TR 198) ✓	2. GOVT ACCESSION NO.	3. RECIPIENT'S CATALOG NUMBER 9 Technical rept. Mar-Dec 77
4. TITLE (and Subtitle) PERSPECTIVE RADAR DISPLAY SYSTEM, TV-like presentation on CRT provides higher lateral position and lateral motion sensitivity than a PPI.	5. TYPE OF REPORT & PERIOD COVERED Evaluation March to December 1977	
7. AUTHOR(s) 10 LG Harris	6. PERFORMING ORG. REPORT NUMBER	
9. PERFORMING ORGANIZATION NAME AND ADDRESS Naval Ocean Systems Center San Diego, California 92152	8. CONTRACT OR GRANT NUMBER(s) 12/2.1p.	
11. CONTROLLING OFFICE NAME AND ADDRESS Naval Sea Systems Command (PMS 300)	10. PROGRAM ELEMENT, PROJECT, TASK AREA & WORK UNIT NUMBERS 17 63516N/S0181 AA/S0181 NOSC 823-CC21	
14. MONITORING AGENCY NAME & ADDRESS (if different from Controlling Office)	12. REPORT DATE 11 17 January 1978	13. NUMBER OF PAGES 18
16. DISTRIBUTION STATEMENT (of this Report) Approved for public release; distribution unlimited.	15. SECURITY CLASS. (of this report) Unclassified	
17. DISTRIBUTION STATEMENT (of the abstract entered in Block 20, if different from Report)	15a. DECLASSIFICATION/DOWNGRADING SCHEDULE	
18. SUPPLEMENTARY NOTES		
19. KEY WORDS (Continue on reverse side if necessary and identify by block number) Antennas - Scanning Display systems - Cathode ray tubes - Electronic equipment - Images - Resolution Performance (human) Plan position indicators Rasters Transformations		
20. ABSTRACT (Continue on reverse side if necessary and identify by block number) The data rate and display format of a conventional navigation radar/PPI display are adequate for most purposes but have limitations in certain close-range applications such as precision maneuvers in low-visibility conditions. At close ranges the PPI format bunches the close targets near the center of the scope where the inherent azimuth resolution is poorest. Close targets may make several degrees of change in relative bearing before the change is noticeable on the PPI display. Also, a small change in heading of "own ship" is not immediately apparent on a PPI display. 2 → next page		

UNCLASSIFIED

SECURITY CLASSIFICATION OF THIS PAGE(When Data Entered)

20. (Cont)

Radar Systems Company has developed a Perspective Radar Display System which provides a perspective presentation on a cathode ray tube of the volume of space being scanned by an electromechanical scanning (non-rotating) radar antenna. This type of display has higher lateral position and lateral motion sensitivity than a PPI display. It has the additional capability of varying the apparent altitude of perspective.

This report covers a technical and operational evaluation of the Perspective Radar Display System to determine its effectiveness as an aid to piloting; for precision maneuvers in low-visibility conditions; for collision avoidance, intercept solution, and shadowing; and for aiding SEAL team cast and recovery operations.

UNCLASSIFIED

SECURITY CLASSIFICATION OF THIS PAGE(When Data Entered)

OBJECTIVE

Investigate the technical and operational advantages and/or disadvantages of the Perspective Radar Display System developed by Radar Systems Company.

RESULTS

The Perspective Radar Display System was evaluated aboard a 65-foot Mark III patrol boat. The evaluation tests measured the effectiveness of the system as an aid for performing precision maneuvers in low-visibility conditions, for piloting, for intercept and rendezvous solutions, and for aiding SEAL team cast and recovery operations.

The evaluation tests showed that the forward-looking perspective view provided by the perspective radar display, used in conjunction with a standard PPI display, provides improved navigation, surveillance, and tactical capabilities for combatant craft.

The perspective radar display has a much higher angular sensitivity than a PPI display, particularly at close ranges, thus enhancing the helmsman's ability to make precision maneuvers and avoid collisions.

The high angular sensitivity, the slewable antenna, and the continuous-scan characteristics combine to provide a precision, simple-to-operate aid to intercept solutions.

The continuous-scan characteristic of the system may provide a new method of passive signaling with various types of radar reflectors.

RECOMMENDATIONS

1. The feasibility of operating the perspective radar display and the PPI display simultaneously should be explored.
2. The perspective radar display image should be expanded to use the entire cathode ray tube area.
3. A zero-degree relative bearing detent and indicator should be provided.
4. A center-line marker should be provided on the display.

ACCESSION for	
NTIS	White Section <input checked="" type="checkbox"/>
DDC	Buff Section <input type="checkbox"/>
UNANNOUNCED	<input type="checkbox"/>
JUSTIFICATION _____	
BY _____	
DISTRIBUTION/AVAILABILITY CODES	
Dist.	AVAIL. and/or SPECIAL
A	

CONTENTS

INTRODUCTION . . .	page 3
DESCRIPTION OF EQUIPMENT . . .	3
EVALUATION METHODS AND RESULTS . . .	7
Training and visual correlation . . .	7
Azimuth and range resolution . . .	8
Piloting and radar fix augmentation . . .	9
Precision maneuvers in low-visibility conditions . . .	9
Shadow, intercept, and rendezvous . . .	10
SEAL Team cast and recovery aids . . .	11
CONCLUSIONS . . .	12
RECOMMENDATIONS . . .	12
APPENDIX: PHOTOGRAPHIC COMPARISON OF PERSPECTIVE RADAR DISPLAY IMAGES WITH LN66 PPI IMAGES . . .	13

INTRODUCTION

The data rate and display format of a conventional navigation radar/PPI display are adequate for most purposes but have limitations in certain close-range applications such as precision maneuvers in low-visibility conditions. At close ranges the PPI format bunches the close targets near the center of the scope where the inherent azimuth resolution is poorest. Close targets may make several degrees of change in relative bearing before the change is noticeable on the PPI display. Also, a small change in heading of "own ship" is not immediately apparent on a PPI display.

The perspective radar display was designed to overcome these limitations and provide additional capabilities as a navigation and surveillance aid for combatant craft. The display provides a perspective presentation on a cathode ray tube of the volume of space being scanned by an electromechanical scanning (nonrotating) radar antenna. The scanning antenna is normally positioned to view the 30 degrees directly ahead of the boat but is manually slewable to any desired azimuth. This type of display, similar to television or forward-looking infrared displays, has higher lateral position and lateral motion sensitivity than a PPI-type display. It has the additional capability of varying the apparent altitude of perspective.

On 22 May 1975 the Perspective Radar Display System was demonstrated at the Naval Amphibious Base, Coronado, California, for Coastal River Squadron One personnel by David Young, of Radar Systems Company. As a result of the favorable reception of the demonstration further evaluation of this system was initiated.

The Naval Ocean Systems Center, Man-System Interface Technology Branch (Code 8236), under the sponsorship of NAVSEA PMS 300, conducted a technical and operational evaluation of the Perspective Radar Display System during the period of 12 October to 11 November 1977. The evaluation was conducted on a Mark III patrol boat (PB751) supplied by Coastal River Squadron One, Amphibious Base, Coronado, California. The evaluation tests were designed to measure the effectiveness of the perspective radar display as an aid to piloting, for precision maneuvers in low-visibility conditions, for shadowing another craft, for performing intercepts and rendezvous, and for aiding SEAL team cast and recovery operations.

The results of the evaluation show that the perspective radar display presents a bright daylight-viewable perspective image to the helmsman, providing him with instant visual feedback to changes in heading and speed of his craft or other craft within his view. The perspective display, in conjunction with a standard PPI display, provides significant improvement over the PPI display alone in collision avoidance, intercept solution, shadowing, and precision maneuvering. It also provides a new means for passive signaling which may be useful in SEAL team cast and recovery operations.

DESCRIPTION OF EQUIPMENT

The Perspective Radar Display System consists of three basic units: a scanning radar antenna, a conventional high-resolution radar set, and a cathode ray tube (CRT) display unit. The scanning radar antenna used on this evaluation is 5 feet long, 5 inches high, and 6

inches deep.* It may be set in a forward-looking position or manually aimed to any desired azimuth. The antenna is electromechanically scanned horizontally at a rate of 55 fields of view per second. The scan angle θ (see fig 1) is about 30 degrees. The elevation beam width α is about 40 degrees and does not scan.

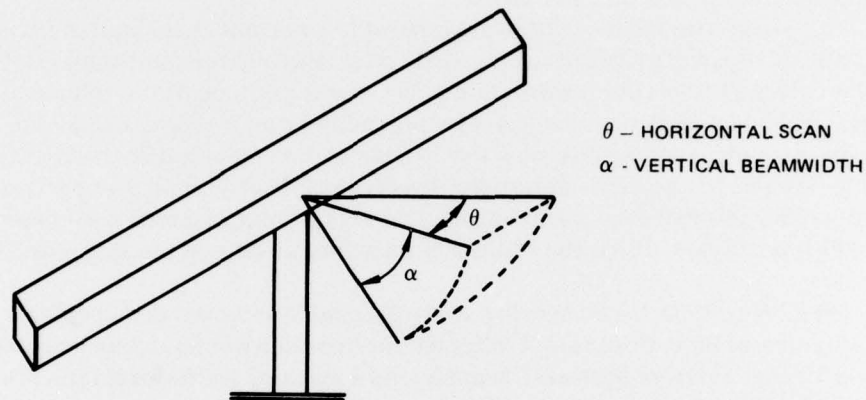

Figure 1. Scanning radar antenna.

The antenna and display are interfaced with an LN66 radar for this evaluation. The radar is externally triggered by the perspective radar display at a pulse repetition rate of 6250 pulses per second. The capability of switching from the scanning antenna to the normal LN66 rotating antenna and from the perspective display to the PPI display is provided.

The perspective radar display unit provides a perspective view of the volume of space scanned by the scanning radar antenna. It is a raster CRT display in which signals appear as bright spots with bearing as the horizontal coordinate and elevation angle as the vertical. The vertical sweep rate is equal to the pulse repetition rate of the radar (6250 pps). The horizontal sweep rate is 55 scans per second, synchronized with the antenna scanner. A control is provided on the control box to change the apparent altitude of the radar antenna. This is accomplished by changing the sweep rate and linearity of the vertical coordinate of the CRT display. The apparent altitude can be adjusted from 100 feet to 1000. This adjustment also affects the minimum and maximum range of the display. The minimum altitude setting displays ranges from 50 feet to 1.3 nmi while the maximum altitude setting displays ranges from 0.45 nmi to about 7 nmi. Range measurements are made with a range strobe (as with a PPI presentation) and displayed on a numerical read-out display located on the control box.

The Perspective Radar Display System is analogous to a closed-circuit television system which has a TV monitor to display the scene from a camera which can see through weather, can be aimed in any direction, and can be adjusted in height from 100 feet (for

*1 in = 25.4 mm
1 degree \approx 0.017 rad

viewing objects at close range) to 1000 feet (for viewing objects at long range). Figure 2 illustrates how two rows of buoys would appear on a standard PPI display and on a perspective display.

Figures 3 and 4 show how the display, the control box, and the scanning antenna were installed on PB 751 for evaluation.

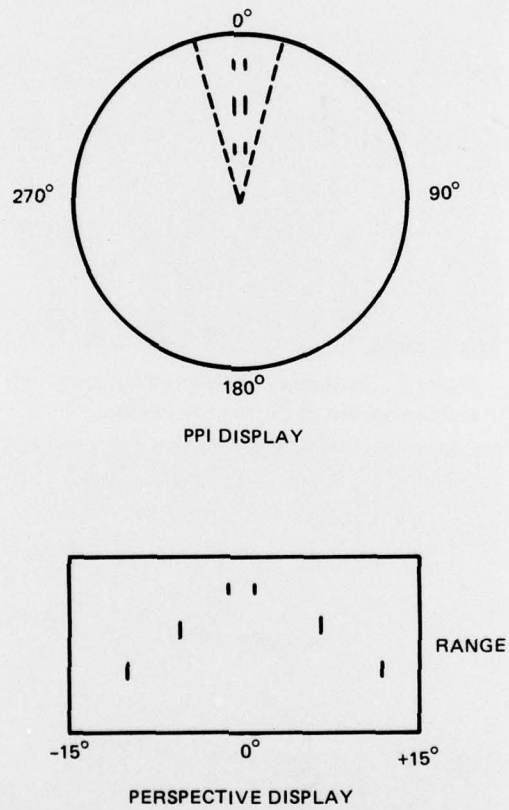
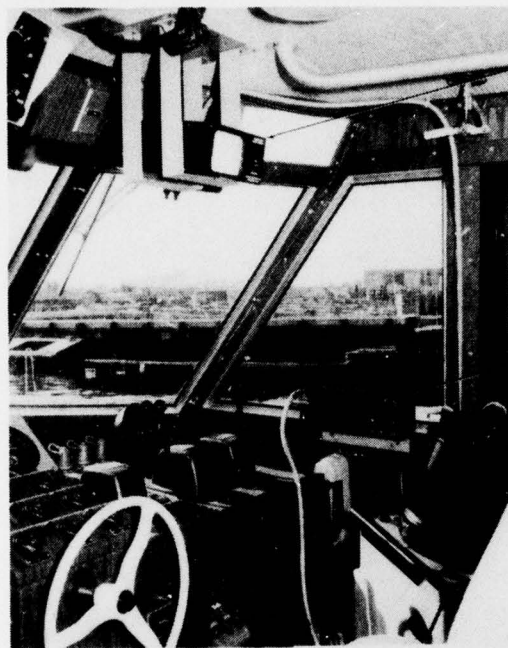

Figure 2. Comparison of PPI display with perspective radar display.



PERSPECTIVE RADAR
DISPLAY UNIT

CONTROL BOX

Figure 3. Installation of perspective display unit and control box in PB 751 pilot house.



LN66 ANTENNA

PERSPECTIVE RADAR
DISPLAY ANTENNA

Figure 4. Perspective radar antenna and LN66 antenna.

EVALUATION METHODS AND RESULTS

TRAINING AND VISUAL CORRELATION

OBJECTIVES

1. Familiarize the crew and test coordinator with the perspective display, controls, and switches.
2. Relate the display images to the visual scenes.
3. Establish optimum settings for the apparent height control, sea clutter control, and antenna azimuth control for the following maneuvers: dock departure, basin exit, pilotage in open channels, coming alongside a ship, basin entrance, and docking.
4. Note any targets that were seen visually but not on the display.
5. Note any false targets seen on the display.

TEST METHODS

Objectives 1 and 2 were met by training sessions conducted by the vendor, objectives 3-5 by hours of hands-on experience.

RESULTS

1. David Young, of Radar Systems Company, instructed the personnel involved in the evaluation on proper operation of the display and on the proper settings of the controls and switches.
2. Because of the perspective nature of the display, relating the display images to the visual scene is simple for radar contacts close enough to be seen visually. The general shape of the contact, its range, and relative bearing are adequate correlation cues.
3. The following optimum control settings were established.

Apparent Height Control: This control affects the apparent height of the radar antenna and the minimum and maximum range of the display. It is set at minimum or near-minimum altitude (150 to 300 feet) for precision maneuvers at close ranges such as docking and undocking and coming alongside a ship or buoy. Medium altitude settings (400 to 600 feet) were used for basin exit and entrance and for plotting. Maximum altitude settings (1000 feet) were used for piloting in open channels and for fixing on large contacts from a distance.

Sea Clutter Control: The sea clutter control on the LN66 is a sensitivity time control with a knob dial which may be set from 1 to 10. A setting of 1 provides maximum video gain at close ranges while a setting of 10 provides minimum video gain at close ranges. For almost all applications a setting of 5 is optimum. Only when looking for a very weak signal would the control be set for maximum gain.

Antenna Azimuth Control: The antenna azimuth control is normally set to 0 degree to look at the ± 15 degrees directly ahead of the boat. It may be slewed to identify terrain on either side of a channel or to line up with a pier or basin entrance before beginning a turn. During an intercept or rendezvous exercise the antenna is centered on the approaching craft.

4. Contacts seen visually but not seen on the display: Virtually all objects seen visually were also seen on the display. Exceptions were objects just barely above the water line such as logs and small floats marking diver positions. The limited range and azimuth resolution of the system (discussed in the following section) prevents the separation of objects too close together. Some types of buoys fade in and out on the display as they sway in the water. Also, distant targets may fade because of multipath cancellation of the radar energy. Because of the continuous-scan feature of the perspective radar display fade-outs are less likely to cause a loss of contact than with a PPI display which scans the area once every 2 or 3 seconds.

5. False Contacts: If the clutter control on the LN66 is set for high gain (less than 5 on the knob), some false contacts may appear on the display because of antenna side lobes. With the clutter control at midrange these side lobes seldom appear. When they do appear, an experienced observer should recognize them as side lobes by their shape.

AZIMUTH AND RANGE RESOLUTION

OBJECTIVES

Measure and compare the azimuth and range resolution of the perspective radar display with that of the LN66 PPI display.

TEST METHODS

PB 751 tied up to mooring buoy FM48 in south San Diego Bay. A rubber boat was dispatched to a red marker buoy 0.10 nmi from FM48. The rubber boat moved away from the buoy in a direction perpendicular to the patrol boat, letting out a measuring line, until two separate spots were discernible on the perspective display. The distance to the buoy was measured and the azimuth resolution calculated. The exercise was repeated to measure the azimuth resolution of the LN66 PPI display.

The rubber boat returned to the marker buoy, then moved directly toward the patrol boat until two separate spots were discernible on the perspective display. The distance to the marker buoy was measured and recorded. This exercise was repeated to measure the range resolution of the LN66 PPI display.

RESULTS

Perspective radar display azimuth resolution: 2.8 degrees

LN66 PPI display azimuth resolution: 2.5 degrees

Perspective radar display range resolution: 61 feet

LN66 PPI range resolution: 78 feet

PILOTING AND RADAR FIX AUGMENTATION

OBJECTIVES

1. Determine the capability of the perspective radar display to identify radar signals which are used for piloting.
2. Determine the speed and convenience of making range and bearing fixes with the perspective radar display.

TEST METHODS

Piloting in a charted channel by radar requires identifying charted points on the radar display and making range and bearing fixes on these points. A night exercise was conducted with Quartermaster Second Class Roy Evans navigating a run from the Amphibious Base piers to the San Diego Bay entrance using the perspective radar display as a navigation aid.

RESULTS

There was little difficulty identifying charted cues such as terrain, channel entrances, large piers, and jetties. Buoys are easily seen on the display but are difficult to distinguish from slow or anchored boats. Also, there are several buoys in San Diego Bay which were uncharted. There was some confusion about which buoy we were plotting to. It was the Quartermaster's first experience with the perspective radar display. He commented that the display should be a good navigation aid for someone experienced in using it.

The range to each plotting point is quickly and easily determined by placing the range strobe on the identified contact displayed on the CRT screen and reading the range from the numerical read-outs on the control box. Relative bearing is read from the antenna compass rose when the antenna is slewed to center the contact on the CRT screen.

PRECISION MANEUVERS IN LOW-VISIBILITY CONDITIONS

OBJECTIVES

Determine the feasibility of depending solely on the perspective radar display for dock departure, basin exit, pilotage in open channels, coming alongside a ship, taking buoys close aboard, collision avoidance, basin entrance, and docking.

TEST METHODS

All the above maneuvers were practiced during high-visibility conditions. Channel pilotage was accomplished at night. On one occasion an exercise was conducted during an early morning fog with 100-yard visibility.

RESULTS

The perspective radar display has a minimum useful range of about 100 feet and an azimuth resolution of about 2.75 degrees. These limitations make docking in zero visibility unsafe because of the inability to discern other craft at the piers. When leaving the dock, one can assume that the presence of other craft at the pier is known.

Basin exit and entrance and pilotage in open channels can be accomplished safely with the perspective display. Taking buoys close aboard (within 100 feet) was demonstrated many times, although what appears to be a buoy on the display may actually be an anchored boat (as is the case with a PPI display).

Collision avoidance with craft or obstacles within the 30-degree look-ahead view angle is much easier than with the PPI display because of the higher angular sensitivity of the display and the visual feedback to the helmsman. The PPI display is needed for 360-degree surveillance of approaching craft. After the PPI has detected a craft approaching outside the 30-degree view angle of the perspective display, the perspective antenna can be slewed to pick up the contact and the perspective display used advantageously to avoid collision.

SHADOW, INTERCEPT, AND RENDEZVOUS

OBJECTIVES

1. Determine the capability of the perspective radar display to aid in shadowing an elusive craft.
2. Determine the capability of the perspective radar display to aid the intercept of or rendezvous with another craft.

TEST METHODS

Several opportunities occurred during the evaluation exercises to shadow other boats. An intercept exercise was planned and conducted off Silver Strand to compare the perspective radar display with the PPI display as an intercept aid.

RESULTS

The perspective radar display provides a high degree of precision for shadowing another craft because of its high sensitivity to angle changes and the visual feedback it supplies the helmsman for any heading changes made by his craft or the pursued craft. The relative speed of his craft to that of the pursued craft may be monitored on the perspective radar display with the aid of the range strobe on the display.

An intercept or rendezvous is accomplished with ease and precision with the perspective radar display. To successfully accomplish an intercept, the closing angle between the two craft must be kept constant. When radar contact is confirmed, the perspective radar antenna is slewed until the radar contact is in the center of the display. The antenna angle remains fixed while the helmsman steers to keep the contact in the center of the display, thus keeping the closing angle constant. The high sensitivity of the display to angle changes results in a more precise intercept than is possible with the PPI display.

SEAL TEAM CAST AND RECOVERY AIDS

The continuous-scan characteristic of the perspective radar display allows short bursts of reflected radar signal to be more easily detected than with a PPI-type radar which scans a given area only once every 2-3 seconds. The possibility of using this characteristic to detect weak signals and to decode passive reflected signals was explored with these tests.

OBJECTIVES

1. Determine the capability of the perspective radar display to detect and track rubber boats and swimmers with and without employing radar reflectors.

TEST METHODS

1. A two-man rubber boat, powered with an outboard motor, was dispatched from the patrol boat and tracked with the perspective radar display to determine the distance it could be reliably tracked.
2. A rotating corner reflector, driven by a battery-operated dc motor was mounted on a tripod and placed on a sand bar 0.34 nmi from the patrol boat. The perspective radar antenna was aimed at the rotating reflector to detect and display the reflected signals from it.
3. A man was placed on the sand bar 0.34 nmi from the patrol boat, holding a wet towel by two corners so the flat surface of the towel would reflect the radar signal back toward the patrol boat. The towel was turned from side to side to simulate signaling.
4. A man went into the water from the sand bar carrying a metalized plastic flat plate 6 by 12 inches in size. While swimming toward the patrol boat, he would occasionally raise the plate from the water and send a signal to the boat.
5. A hand-held corner reflector was placed in the rubber boat. The men in the boat would periodically aim the corner reflector toward the patrol boat to flash a signal on the perspective display.

RESULTS

1. The rubber boat carrying two men was "skin" tracked reliably for 0.5 nmi in calm water.
2. The rotating corner reflector clearly sent a dit dit dah signal to the perspective radar display as the radar signal reflected from the two flat sides (producing the dit, dit) and the center of the V (producing the dah).
3. The reflections from the wet towel were not strong enough relative to the reflections from the man's body to produce a clear signal. This may have been due to lack of flatness of the towel surface as it was rotated back and forth.
4. The swimmer in the water was not detected on the display without the aid of a reflector. When he raised the flat reflecting plate from the water and held it perpendicular

to the patrol boat, a bright flash was seen on the display. A better method of aiming the reflector needs to be developed. The swimmer often failed to aim it properly.

5. When the men in the rubber boat aimed the corner reflector toward the patrol boat, the image on the display would clearly brighten. Again, a better method of aiming the reflector should be devised to improve its reliability as a signaling device.

CONCLUSIONS

1. The evaluation tests showed that the Perspective Radar Display System, used in conjunction with a standard PPI display, provides improved navigation and collision avoidance capabilities during low-visibility conditions.

2. The bright, perspective, look-ahead display provides the helmsman with real-time visual feedback following any change of heading or speed. If the display is properly located, the helmsman can view it without distraction from visually steering the boat.

3. The perspective radar display is more sensitive to angular changes of the boat or of an approaching craft than a PPI display. This allows more precise heading control of the boat plus better, faster, and safer maneuverability in low-visibility conditions.

4. The continuous-radar-scan characteristic of the system permits the reception and display of quick changes in signal strength. This may provide a new method of passive signaling with corner reflectors or other reflective devices.

5. Intercept, rendezvous, and shadowing exercises are easier and more precise with the perspective radar display. These exercises can be accomplished by the helmsman with little or no assistance from the radarman.

6. The identification capability of the perspective radar display is no better or worse than that of the PPI display.

RECOMMENDATIONS

1. The feasibility of operating two X-band radars simultaneously on the same craft should be investigated to allow simultaneous operation of the perspective radar display and the PPI display.

2. The perspective radar display evaluated used only about half the usable CRT area. Expansion of the horizontal sweep would cause discrete raster lines to be visible on the display because of the low vertical sweep rate. Techniques should be explored to increase the vertical sweep rate and expand the sweep area to display a larger picture on the CRT.

3. A zero-degree relative bearing detent should be provided on the antenna positioning lever. An indicator on the display should confirm that the antenna is looking straight ahead.

4. A center line or marker should be provided on the display to aid in centering a contact for shadowing and intercept solutions.

**APPENDIX:
PHOTOGRAPHIC COMPARISON OF PERSPECTIVE RADAR DISPLAY IMAGES
WITH LN66 PPI IMAGES**

In the following photographs the "A" view shows the perspective display image while the "B" view shows the PPI view of the same area with the 30-degree perspective view marked on the photograph. In the "B" views of figures A3 and A4 the 30-degree sector mark does not originate at the center of the PPI display because there was a delay between the time the PPI photograph was taken and the time the perspective display photograph was taken.

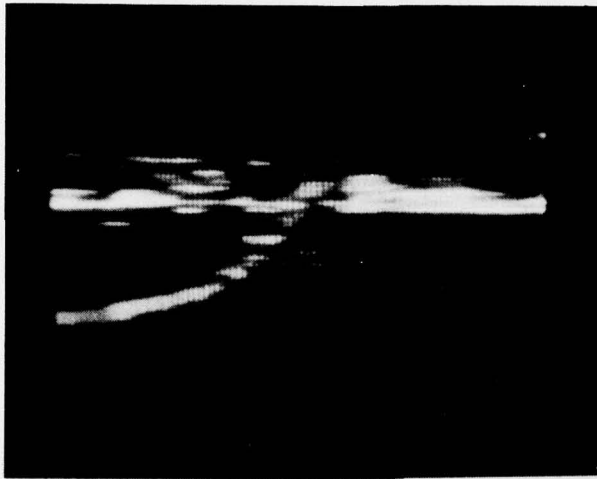

Figure A1A
Perspective Radar Display
700-ft Altitude
Coronado Bay Bridge from
Amphibious Base Pier

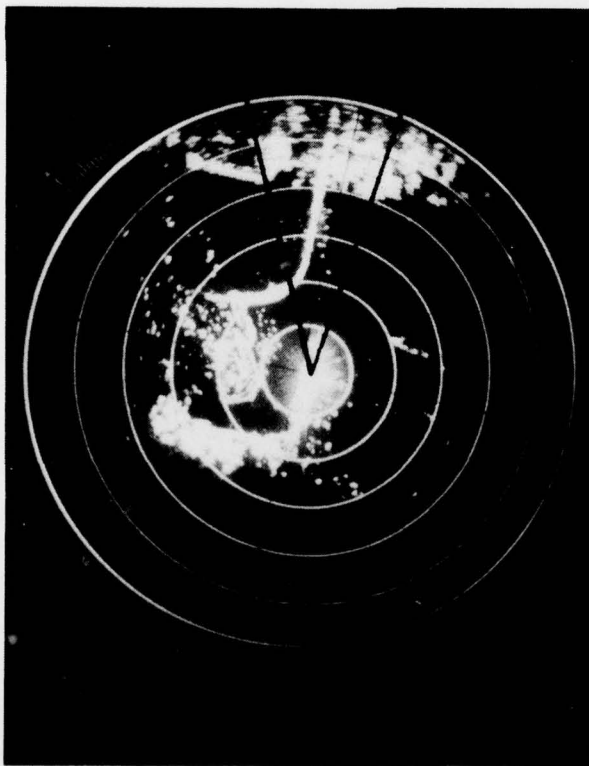

Figure A1B
PPI Display
0.5-nmi Range
0.25-nmi Range Rings

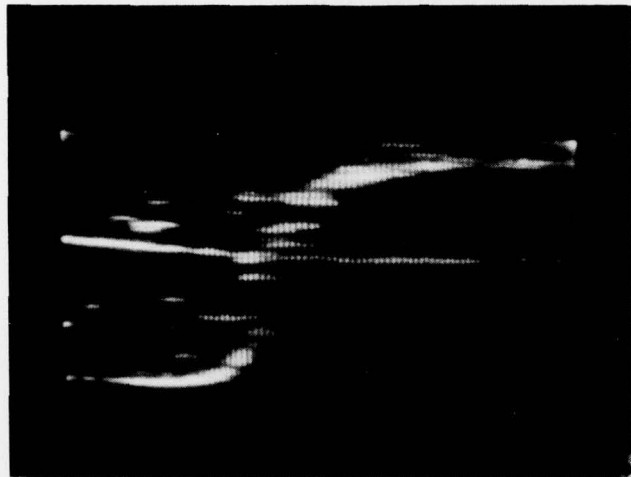

Figure A2A
Perspective Radar Display
1000-ft Altitude
Coronado Bay Bridge
from San Diego Bay near
5th Avenue

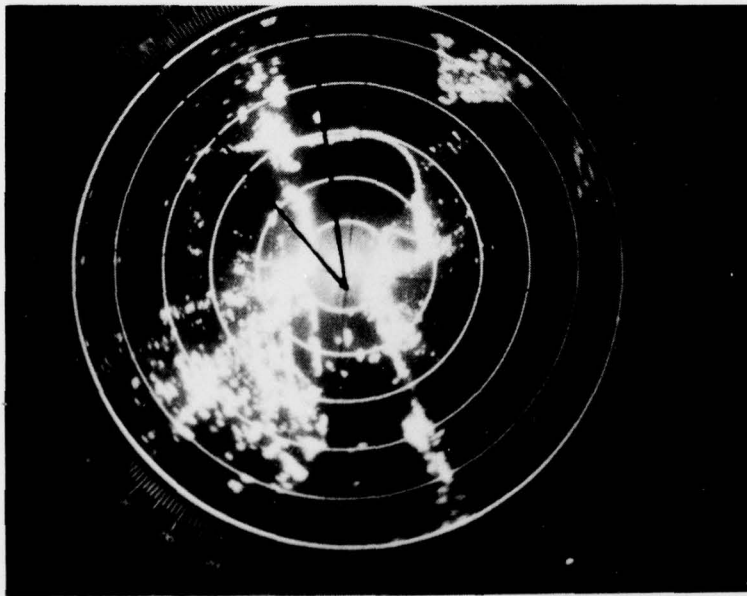

Figure A2B
PPI Display
1.5-nmi Range
0.25-nmi Range Rings

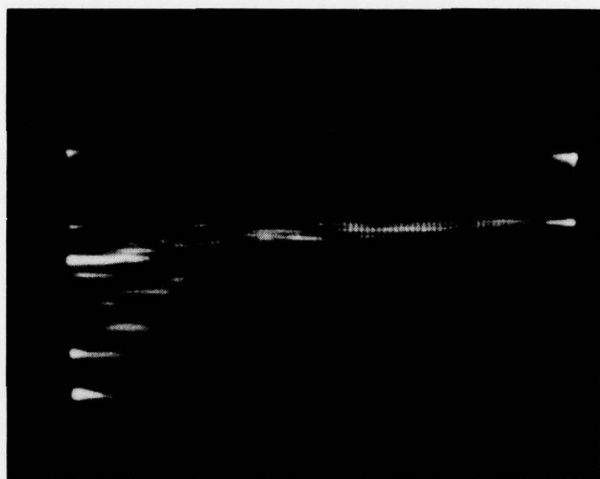

Figure A3A
Perspective Radar Display
1000-ft Altitude
Glorietta Bay



Figure A3B
PPI Display
0.75-nmi Range
0.25-nmi Range Rings

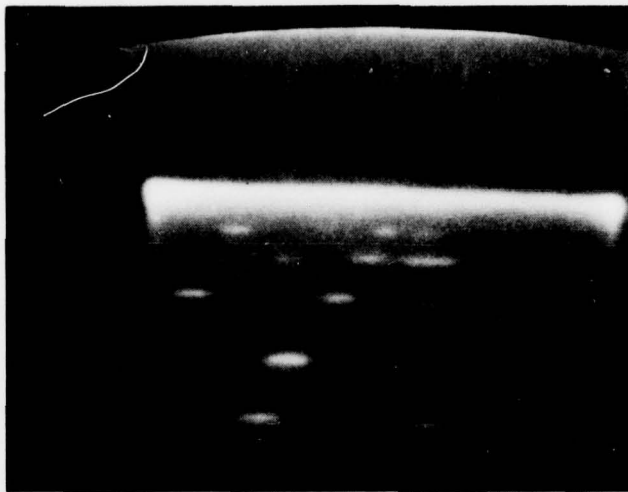

Figure A4A
Perspective Radar Display
1000-ft Altitude
Row of Buoys at Entrance
to San Diego Bay

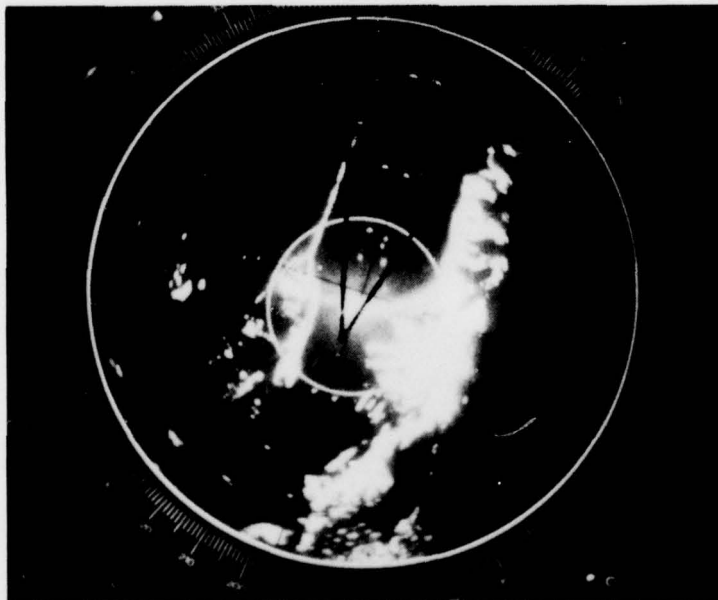

Figure A4B
PPI Display
1.5-nmi Range