

AD-A052 436

COAST GUARD RESEARCH AND DEVELOPMENT CENTER GROTON CONN F/6 13/4
FIRE EXPOSURE TESTS OF POLYETHYLENE AND FIFTY-FIVE GALLON STEEL--ETC(U)
AUG 77 R C RICHARDS, G J MUNKENBECK

UNCLASSIFIED

C6R/DC-20/77

USCG-D-86-77

NL

1 of 2
AD A052436



Report No. CG-D-86-77

12

AD A 052436

FIRE EXPOSURE TESTS OF POLYETHYLENE AND FIFTY-FIVE
GALLON STEEL DRUMS LOADED WITH FLAMMABLE LIQUIDS
PHASE II

R. C. Richards and G. J. Munkenbeck, Jr.
U.S. Coast Guard Research and Development Center
Avery Point, Groton, Connecticut 06340



August 1977

Final Report

Document is available to the public through the
National Technical Information Service,
Springfield, Virginia 22151

Prepared for
DEPARTMENT OF TRANSPORTATION
UNITED STATES COAST GUARD
Office of Research and Development
Washington, D.C. 20590

DDC
RECEIVED
APR 3 1978
E

AD No. []
DDC FILE COPY

DISTRIBUTION STATEMENT A
Approved for public release;
Distribution Unlimited

NOTICE

This document is disseminated under the sponsorship of the Department of Transportation in the interest of information exchange. The United States Government assumes no liability for its contents or use thereof.

The United States Government does not endorse products or manufacturers. Trade or manufacturers' names appear herein solely because they are considered essential to the object of this report.

The contents of this report reflect the views of the Coast Guard Research and Development Center, which is responsible for the facts and accuracy of data presented. This report does not constitute a standard, specification or regulation.

D. L. Birkimer

DONALD L. BIRKIMER, Ph.D., P.E.
Technical Director
U.S. Coast Guard Research and Development Center
Avery Point, Groton, Connecticut 06340

18 715CG

19 D-86-77

1. Report No. CG-D-86-77 ✓		2. Government Accession No.		3. Recipient's Catalog No.	
6. Title and Subtitle FIRE EXPOSURE TESTS OF POLYETHYLENE AND FIFTY-FIVE GALLON STEEL DRUMS LOADED WITH FLAMMABLE LIQUIDS, PHASE II.		5. Report Date 11 August 1977		6. Performing Organization Code 12 102P.	
7. Author(s) 10 R. C. Richards and G. J. Munkenbeck, Jr		8. Performing Organization Report No. 14 CGR/DC-28/77		10. Work Unit No. (TRAIS)	
9. Performing Organization Name and Address United States Coast Guard Research and Development Center Avery Point Groton, CT 06340		11. Contract or Grant No. DOT-A5-60071		13. Type of Report and Period Covered 9 Final Report.	
12. Sponsoring Agency Name and Address Department of Transportation Materials Trans. Bureau Office of Hazardous Material Operations Washington, DC 20590		14. Sponsoring Agency Code MTH-1			
15. Supplementary Notes Performed at the U.S. Coast Guard Fire and Safety Test Detachment under the technical control of the Coast Guard Research and Development Center.					
16. Abstract Tests were conducted to compare the resistance of steel and polyethylene drums to fire exposure. Fire exposures were varied from 90 square foot fires completely engulfing the drum to 25 square foot fires exposed to one side of the drum. Lubricating oil, JP-4 (aviation fuel), and ethyl ether were used in the drums to examine the effects of cargo volatility. The internal pressure, internal temperature, external temperature, temperature at the bung, time to failure, and mode of failure were recorded for each drum tested. The results agree with previous tests. Polyethylene drums fail by melting and collapsing into the fire. Steel drums fail by jetting and/or exploding. The size of the fire had no significant effect on the time to failure for polyethylene drums and an effect could not be determined for steel drums due to inconsistencies in manufacturing. Both types of drums fail within the same length of time when loaded with cargos more volatile than JP-4. The polyethylene drums fail 3 to 4 minutes sooner than steel drums loaded with fuels in the volatility range of JP-4 or lower.					
17. Key Words drums, flammable liquids, drum fires, ship fires, marine safety, hazardous materials transportation			18. Distribution Statement Document is available to the U.S. public through the National Technical Information Service, Springfield, Virginia 22161		
19. Security Classif. (of this report) UNCLASSIFIED		20. Security Classif. (of this page) UNCLASSIFIED		21. No. of Pages	22. Price

408 730 JOB

METRIC CONVERSION FACTORS

Approximate Conversions to Metric Measures

Symbol	When You Know	Multiply by	To Find	Symbol
LENGTH				
in	inches	*2.5	centimeters	cm
ft	feet	30	centimeters	cm
yd	yards	0.9	meters	m
mi	miles	1.6	kilometers	km
AREA				
in ²	square inches	6.5	square centimeters	cm ²
ft ²	square feet	0.09	square meters	m ²
yd ²	square yards	0.8	square meters	m ²
mi ²	square miles	2.6	square kilometers	km ²
	acres	0.4	hectares	ha
MASS (weight)				
oz	ounces	28	grams	g
lb	pounds	0.45	kilograms	kg
	short tons (2000 lb)	0.9	tonnes	t
VOLUME				
tsp	teaspoons	5	milliliters	ml
Tbsp	tablespoons	15	milliliters	ml
fl oz	fluid ounces	30	milliliters	ml
c	cups	0.24	liters	l
pt	pints	0.47	liters	l
qt	quarts	0.95	liters	l
gal	gallons	3.8	liters	l
ft ³	cubic feet	0.03	cubic meters	m ³
yd ³	cubic yards	0.76	cubic meters	m ³
TEMPERATURE (exact)				
°F	Fahrenheit temperature	5/9 (after subtracting 32)	Celsius temperature	°C

Approximate Conversions from Metric Measures

Symbol	When You Know	Multiply by	To Find	Symbol
LENGTH				
mm	millimeters	0.04	inches	in
cm	centimeters	0.4	inches	in
m	meters	3.3	feet	ft
m	meters	1.1	yards	yd
km	kilometers	0.6	miles	mi
AREA				
cm ²	square centimeters	0.16	square inches	in ²
m ²	square meters	1.2	square yards	yd ²
km ²	square kilometers	0.4	square miles	mi ²
ha	hectares (10,000 m ²)	2.5	acres	acres
MASS (weight)				
g	grams	0.035	ounces	oz
kg	kilograms	2.2	pounds	lb
t	tonnes (1000 kg)	1.1	short tons	short tons
VOLUME				
ml	milliliters	0.03	fluid ounces	fl oz
l	liters	2.1	pints	pt
l	liters	1.06	quarts	qt
l	liters	0.26	gallons	gal
m ³	cubic meters	35	cubic feet	ft ³
m ³	cubic meters	1.3	cubic yards	yd ³
TEMPERATURE (exact)				
°C	Celsius temperature	9/5 (then add 32)	Fahrenheit temperature	°F

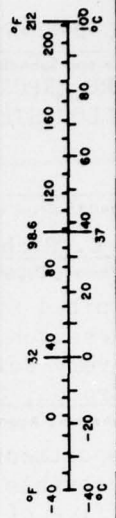
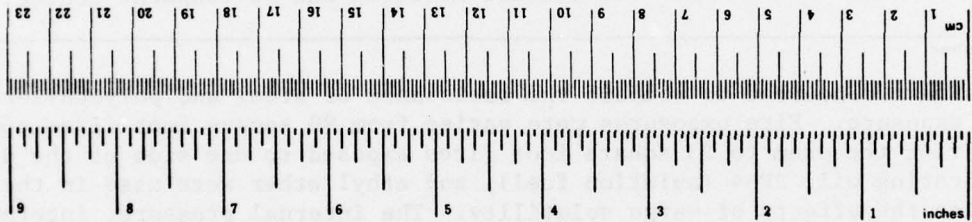

* 1 in = 2.54 (exact). For other exact conversions and more detailed tables, see NBS Misc. Publ. 286, Units of Weights and Measures, Price \$2.25, SD Catalog No. C13.10.286.

ACKNOWLEDGEMENTS

The Coast Guard R&D Center appreciates the assistance of the Hedwin Corporation, Baltimore, Maryland, in providing drums to be tested, and the Naval Surface Weapons Center, White Oak, Silver Spring, Maryland, in providing the hydrostatic testing for steel drums.

ACCESSION FOR		
NTIS	Wide Section	<input checked="" type="checkbox"/>
DDC	B Section	<input type="checkbox"/>
UNANNOUNCED		<input type="checkbox"/>
JUSTIFICATION		
BY		
DISTRIBUTION/AVAILABILITY CODES		
Dist.	AVAIL.	SPECIAL
A		

TABLE OF CONTENTS

	<u>Page</u>
1.0 PURPOSE AND SUMMARY	1
2.0 BACKGROUND	3
3.0 TEST PROCEDURES	4
3.1 The Fire Pan and Fire	4
3.2 Drum Cargos	4
3.3 Instrumentation	4
3.4 Single Drum Tests	9
3.5 Drum Array Tests	11
3.6 Hydrostatic Drum Tests	11
3.7 Limitations	11
4.0 OBSERVATIONS AND RESULTS	12
4.1 Twenty-Five Square Foot Partial and Full Exposure Fires	12
4.1.1 Five-Gallon Blow-Molded Polyethylene Drums	12
4.1.2 Fifteen-Gallon Blow-Molded Polyethylene Drums	14
4.1.3 Thirty-Gallon Blow-Molded Polyethylene Drums	14
4.1.4 Fifty-Five Gallon Blow-Molded Polyethylene Drums	15
4.1.5 Fifty-Five Gallon Steel Drums	16
4.2 Ninety Square Foot Full Exposure Fires With 55-Gallon Drums	16
4.2.1 Blow-Molded Polyethylene Drums	19
4.2.2 Specification 17E Steel Drums	19
4.2.3 Specification 5B Steel Drums	20
4.3 Specification 5B Drum Array Test	21
4.4 Hydrostatic Tests of Steel Drums	23
4.5 Data for Pressure-Relieving Devices	29
5.0 DISCUSSION	30
5.1 Effects of Fire Exposure	30
5.2 Effects of Drum Cargo	30
5.3 Effects of Drum Type/Construction	32
6.0 CONCLUSIONS	34
APPENDIX A - SPECIFICATIONS FOR DRUMS TESTED	A-1
APPENDIX B - MANUFACTURER'S INFORMATION ON DRUMS TESTED	B-1
APPENDIX C - DATA FOR 25 SQUARE FOOT PARTIAL AND FULL EXPOSURE FIRES (TESTS 1 THROUGH 8, 11 AND 12)	C-1
APPENDIX D - DATA FOR 90 SQUARE FOOT FULL EXPOSURE FIRES WITH FIFTY-FIVE GALLON DRUMS (TESTS 9, 10, AND 13 THROUGH 18)	D-1

LIST OF ILLUSTRATIONS

<u>Figure</u>		<u>Page</u>
1	Fire Pan and Table	5
2	Liquid Heat Capacities for JP-4, Acetone, and Ethyl Ether	7
3	Saturated Vapor Pressure Versus Temperature for JP-4, Acetone and Ethyl Ether	8
4	55-Gallon Drum Instrumented for Testing	10
5	30-Gallon Polyethylene Drum Collapsing into 25 Square Foot Partial Exposure Fire	17
6	Jetting Failure of Ethyl Ether in a Specification 5B Drum Exposed to a 90 Square Foot Fire	22
7	Failure During an Array Test of Specification 5B Drums	24
8	Hydrostatic Test of a Specification 5B Drum Prior to Failure	26
9	Point of Failure of a Specification 5B Drum During Hydrostatic Tests	27
10	A Specification 17E Drum Compared to Two Which Failed During Hydrostatic Tests	28

LIST OF TABLES

<u>Table</u>		<u>Page</u>
1	Comparative Information on Lubricating Oil, JP-4, Acetone, and Ethyl Ether	6
2	Data Summary for Failure of Polyethylene Drums	13
3	Data Summary for Failure of 55-Gallon Steel Drums	18
4	Times to Failure for Specification 5B Drums in an Array Exposed to a 90 Square Foot Fire	25
5	Average Time to Failure for Increasing Exposures of Drums to JP-4 Fires	31

1.0 PURPOSE AND SUMMARY

Polyethylene drum manufacturers and users are interested in obtaining government approval of their products for the transportation of flammable liquids. Based on this interest, Phase I* of the test series was carried out to investigate the following questions:

- a. How do 55-gallon steel drums fail in fire situations?
- b. How do 55, 30, 15 and 5-gallon polyethylene drums fail in fire situation?
- c. Which fails first, a 55-gallon polyethylene drum or a 55-gallon steel drum?
- d. Which failure is most dangerous, the 55-gallon steel or the 55-gallon polyethylene drum?
- e. Is it safer to ship flammable liquids in many small polyethylene drums or a few large (55-gallon) polyethylene drums?

From the performance of the polyethylene drums exposed to fire in Phase I tests, it appeared that they might be a safer means of shipment for highly volatile flammable liquids because their failures were less catastrophic. Accordingly, this second phase of testing was requested by the Materials Transportation Bureau of the Department of Transportation and carried out by the Coast Guard on 8-18 November 1976. The Phase II testing was designed to explore the following:

- a. In the previous series,* the time to failure of the steel drums decreased, while the time to failure of the polyethylene drums remained the same or increased, with increased cargo volatility. Determine if this relationship noted when comparing the results of JP-4 and acetone-filled drums is valid for higher and lower volatility liquids.
- b. Determine the mode, pressure and time of failure of higher integrity 55-gallon steel drums.
- c. Determine what effect a small surface area fire would have on the time to failure for polyethylene and steel drums.
- d. Obtain data to be used in the design of pressure-relieving systems for steel drums to minimize or eliminate possible explosive failure.

The results show that the time to failure for steel drums in a fire does decrease with increased volatility while the time to failure remains relatively constant for polyethylene drums in spite of cargo volatility changes. When this information is combined with the fact that steel drums fail catastrophically

*"Fire Exposure Tests of Polyethylene and Fifty-Five Gallon Steel Drums Loaded with Flammable Liquids - Phase I," R. C. Richards and K. T. White, September 1976, DOT Report Number CG-D-116-76.

with a jet-like torch and/or an explosive fire ball, it becomes apparent that the melting and collapsing of polyethylene drums is the preferred failure mode. The higher integrity Specification 5B 55-gallon steel drums fail in a similar manner as the Specification 17E drums and do not provide a significant increase in the time to failure.

The effect of the size of the fire was negligible for polyethylene drums. If the fire was hot enough to melt a small area, the drum would release its cargo to the fire resulting in increased fire severity. The effect of the size of the fire on steel drums was inconclusive. This was caused by the wide scatter in the pressure at which the steel drums failed which in turn affected the time to failure. The reason for this scatter is believed to be defects and inconsistencies in manufacturing the drums.

2.0 BACKGROUND OF DRUM USE AND TESTING

Present regulations imply that steel drums are the standard means of shipping small quantities of flammable liquids in marine transportation. Questions with regard to these regulations have been raised because of the superior impact resistance of the 55-gallon polyethylene drum compared to its steel counterpart. The National Bureau of Standards and the U.S. Navy have demonstrated this impact resistance in drop tests and other experimentation for DOT. Why then are 55-gallon polyethylene drums used only by special permit? One reason is that at a temperature between 75°C and 180°C polyethylene will melt and burn. The result is more complicated when steel drums are exposed to similarly high temperatures. With them, some of the heat is transferred to the cargo, the internal pressure may increase to the point where a violent failure can occur releasing the drum's flammable cargo to the fire.

3.0 TESTING AND PROCEDURES

3.1 The Fire Pan and Fire

The test pan (Figure 1) was constructed so that a table, fabricated from angle iron which could accept 2"x4" wooden slats, could be placed inside it. During the tests involving polyethylene drums, the legs of the table sat on diaphragms in the bottom of the tank and were supported by a weighing (load cell) system. During the steel drum tests, the table sat directly on the bottom of the fire pan to prevent possible damage to the sensors. Water was placed in the pan, level with the table to insulate the table and instruments as well as to provide a surface on which to float the fire fuel. To reduce the fire area for the 25 square foot fires, a steel ring 6 inches high was placed on top of the fire pan table and then filled with fuel.

For safety reasons all single steel drum tests were conducted with the drum enclosed in a steel safety cage. The cage prevented the test drum from becoming a missile if it exploded and reduced the size of fire balls by restricting its movement.

In order for the results to be consistent with Phase I testing, JP-4, fuel, was again used as the fire fuel. It was chosen for use in the first phase for its low cost, and known physical properties. No special equipment or chemicals are needed to extinguish it.

3.2 Drum Cargos

Several cargos were used in both phases of the tests. In Phase I, JP-4 and acetone were used as the drum cargos. In this series JP-4 was again chosen as one of the cargos so the results of the smaller fires could be compared with the 90 square foot fires previously used. As a cargo, it approximates toluene or octane in volatility.

Ethyl ether was also chosen for Phase II tests as the high volatility cargo since it is the most volatile substance commonly shipped. Lubricating oil was chosen for the low volatility cargo. Specifically, Grade 9250 was chosen for the tests since it was readily available through the Federal supply system and is a common engine lubricant. Water was also used as a cargo to provide a way of measuring the total heat absorbed by the drum.

Table 1 compares JP-4, ethyl ether, and lubricating oil. Figure 2 graphically displays the liquid heat capacities and Figure 3 shows the saturated vapor pressures of these liquids.

3.3 Instrumentation

As mentioned in Section 3.1, a system of four load cells was used to determine test drum weight changes. The system had a 20,000-pound capacity and was accurate to +3 pounds. Type K thermocouples were used to measure internal and external temperatures. The internal thermocouple was placed five inches into the cargo. The external thermocouples were arranged at the four

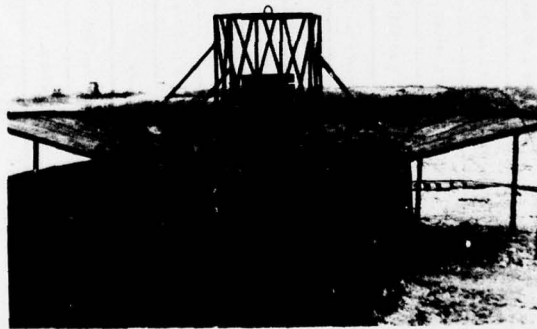
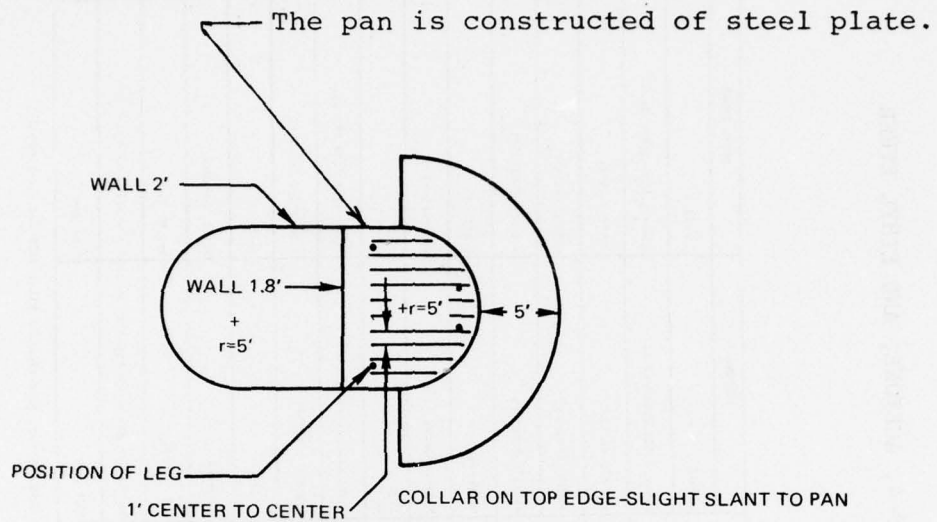

View of fire pan and table set up for test of 55 gal steel drum. Cage was added for safety after explosion of initial test drum.

FIGURE 1

FIRE PAN AND TABLE

TABLE 1

COMPARATIVE INFORMATION ON LUBRICATING OIL, JP-4, ACETONE, AND ETHYL ETHER

	LUBRICATING OIL	JP-4	ACETONE	ETHYL ETHER
Physical State	Liquid	Liquid	Liquid	Liquid
Explosive Limits (by volume in air)	Data not available	Lower 1.3%, Upper 8.0%	Lower 2.6%, Upper 12.8%	Lower 1.85%, Upper 36.5%
Flash Point	+150°C to +235°C (+300°F to +450°F)	-23.3°C to -1.1°C (-10°F to +30°F)	-17.8°C (0°F)	-45°C (-49°F)
Autoignition Temperature	+260°C to +370°C (+500°F to +700°F)	+240°C (+464°F)	+560°C (+1040°F)	+180°C (+356°F)
Boiling Point	+360°C (+680°F)	+176°C to +287°C (+349°F to +549°F)	+56.1°C (+133°F)	+34.6°C (+94.3°F)
Color	Dark yellow to light brown	Colorless to light brown	Colorless	Colorless
Corrosivity	Non-corrosive	Non-corrosive	Non-corrosive	Non-corrosive
Liquid Density (lb/cu ft) @ 40°F (Linear Over Range) @ 100°F	53 53	48.4 46.5	50.4 48.1	45.6 43.3
Heat of Vaporization at Boiling Point	Not pertinent	78 cal/g (140 BTU/lb)	7.092 kilocalories/mole	84.9 cal/g (153 BTU/lb)
Melting Point (Freezing Point)	Not pertinent	-48°C (-54°F)	-93.9°C (-137°F)	-116.3°C (-177.3°F)
Molecular Weight	Mixture	Mixture	58.08	74.12
Odor	Like fuel oil	Like fuel oil	Sweetish	Sweet, pungent
Vapor Pressure at +20°C (+68°F)	Not pertinent	72.4 mm Hg	181.7 mm Hg	442 mm Hg
Water Solubility (miscibility)	Not soluble	Not soluble	Soluble in all proportions in water	7.5 gms/100 ml H ₂ O @ 20°C
Threshold Limit (toxicity)	Not pertinent	200 ppm	1000 ppm	0.83 ppm

(Source: Chemical Safety Data Sheet SD-87-Acetone-Manufacturing Chemists Association; CHRIS Hazardous Chemical Data, CG-446, Specification MIL-T-5624 and MIL-L-9000C)

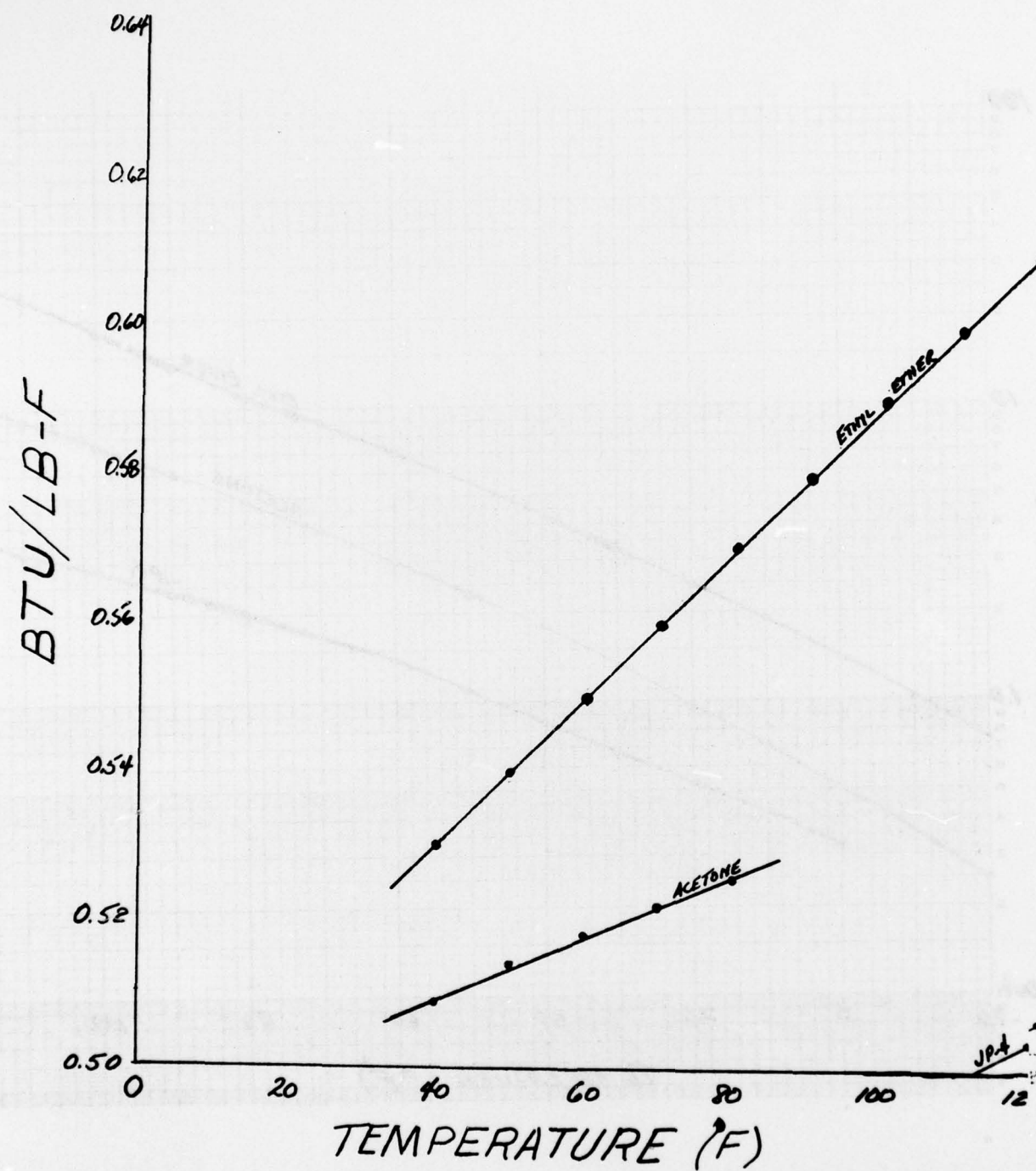

FIGURE 2

LIQUID HEAT CAPACITIES FOR JP-4, ACETONE, AND ETHYL ETHER

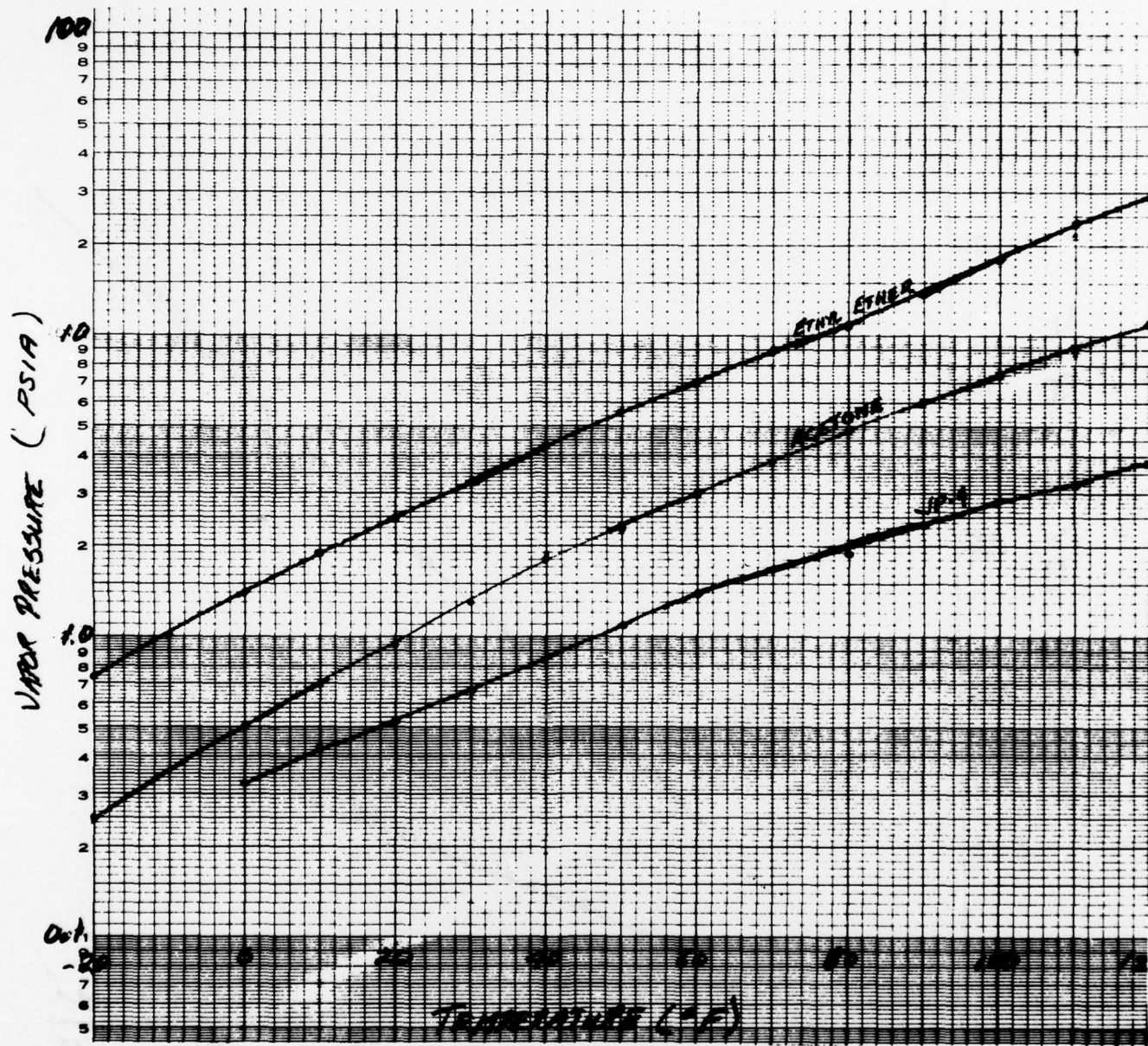

FIGURE 3

SATURATED VAPOR PRESSURE VERSUS TEMPERATURE FOR JP-4, ACETONE, AND ETHYL ETHER

cardinal points of the compass and located between one and two inches from the drum's surface. They were secured by banding placed around the middle of each drum. This steel banding also served to simulate the steel banding normally used to secure cargo being shipped. On steel drums an additional thermocouple was placed in contact with the two-inch drum bung to record its temperature. A pressure transducer was connected to the inside of the drum via a tube to measure internal drum pressure.

Entry into the drum for the thermocouple and pressure transducer piping was made through the bung. Figure 4 shows a drum fully instrumented for a test. For steel drums, steel fittings replaced the bungs. The two-inch bung hole was used for the thermocouple and the 3/4-inch bung hole was used for the pressure transducer. For polyethylene drums a special Teflon bung was used to reduce any error which might be introduced from the metal instrumentation leads. Since Teflon melts at a higher temperature than polyethylene, it acted as an insulator. In fact, the Teflon bungs frequently survived the fire and could be re-used.

The output of these instruments and secondary data (i.e., wind speed and direction, ambient temperature and pressure) were digitized and recorded on paper tape for computer data reduction. In addition to this data, still photographs were taken of all tests and motion picture and/or video tapes were taken of selected tests.

3.4 Single Drum Tests

Steel drums conforming to 49 CFR (Code of Federal Regulations) 178.82 (Specification 5B) and 49 CFR 178.116 (Specification 17E) were compared to polyethylene drums conforming to 49 CFR 178.19 (Specification 34) and, in the case of the 55-gallon polyethylene drums, to drums permitted by Exemption to Specification 34 (Special Permits). During this series, only blow-molded polyethylene drums were tested as these are more commonly used. Appendix A details the specific regulations. Appendix B describes the specific drums used in this series. The Specification 17E drums were chosen to insure comparable data between this series and Phase I (1). The Specification 5B drums were chosen for the higher degree of integrity they provide and the fact that these are more generally used than all welded (Specification 5A) types. The polyethylene drums were chosen during the Phase I tests on the basis of cost and availability and are felt to be representative of those on the market today.

Each drum loaded with flammable liquid was tested to failure. For the purposes of these tests, time to failure is defined as the time (minutes and seconds) between the ignition of the pan fire and failure. Failure is defined as any loss of weight due to a discharge of cargo as recorded by the load cell instrumentation. A five-pound or sudden decrease in weight was typically noted. This definition was used in all the polyethylene tests. In addition, "visible failure" was recorded when it could be observed. This was defined as any visible leak, which allowed cargo to escape.

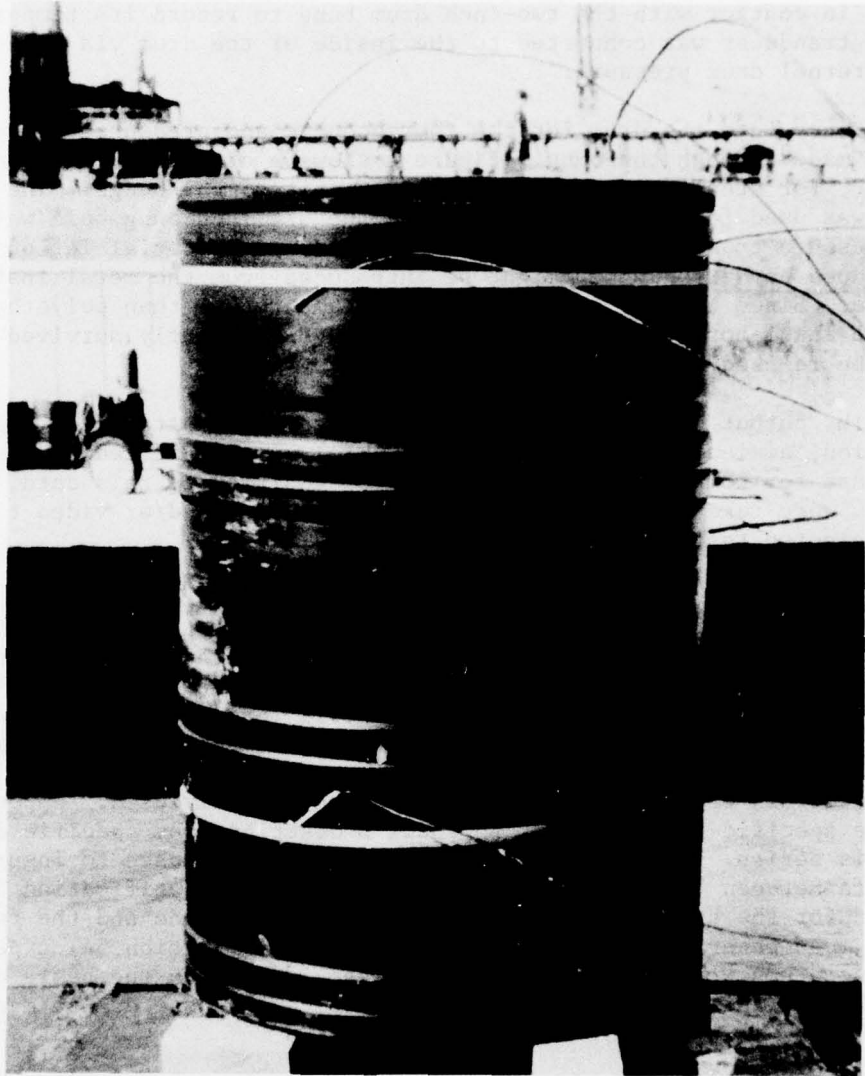

FIGURE 4

55-GALLON DRUM INSTRUMENTATION FOR TESTING

In steel drums a decrease of five pounds per square inch gage in internal drum pressure defined failure. In most cases, the steel drum failure was visible to the naked eye. For both steel and polyethylene drums, the failure points were based on the same criteria used in Phase I.

The general test sequence for the single drum tests was as follows. The test drum was filled to rated capacity with the cargo liquid. Regulations (49 CFR 178.19-3 and 178.116-2) require an air space above the liquid in the drum. Care was taken to comply. In all cases involving flammable cargos except the ethyl ether, the drums were filled less than five minutes before they were tested. The steel drums were filled with ethyl ether several days in advance of the tests for safe handling reasons. This is not considered to have any effect on the test results. The polyethylene drums were filled with ethyl ether the morning of the test.

3.5 Drum Array Tests

Since each type of drum tested in Phase I was also tested as an array, an array test was run on the Specification 5B drums to provide comparative data. This array test simulated field conditions, simulating how a cluster of drums is stored or shipped. The drums were closely packed as they would be in shipment. The array was set up in the pan similar to the single drums, with the exception of instruments, which were omitted due to the high probability of explosive damage. The Specification 5B drums were filled with 660 gallons of JP-4, giving an equal fire load in both phase. The fire was ignited and allowed to burn out.

3.6 Hydrostatic Drum Tests

Hydrostatic tests to failure were conducted on each of three steel drums of Specification 17E and 5B, selected at random from the drums purchased for this phase. These tests were done to determine the internal pressures a steel drum could withstand at ambient temperatures.

This testing was conducted at the Naval Surface Weapons Center, White Oak, Silver Spring, Maryland, under the direction of Mr. L. D. Rau. For these tests, each drum was filled with water and then connected to a surge tank which was also filled with water and pressurized with air to 3000 pounds per square inch gage. This setup was controlled so water could enter the drums and the pressure could be increased at 16 psig/min for the first test and 80 psig/min for the other two tests. The two different rates of pressure rise were chosen to see if pressure rate would affect the drum's failure. Each drum was pressurized until it failed.

3.7 Limitations

Each fire was affected by the wind which caused different amounts of heat to impinge on each drum. The more wind, the less heat available at the surface of the drum. The major effect was the increased length of time to failure as the heat input decreased.

4.0 OBSERVATIONS AND RESULTS

4.1 Twenty-Five Square Foot Partial and Full Exposure Fires

Questions have been raised as to the effect of a smaller fire on the failure times of drums. The hypothesis was that the time to failure would increase if the fire exposure were decreased. To test this, drums were exposed to 25 square foot partial and full exposure fires in Tests 1 through 8, 11 and 12. In the partial exposure tests, the drum was placed on the edge of the boundary ring containing the fire. It was always placed on the upwind side, thus the partial fire exposure covered approximately 50 percent of the drums vertical surface. In the full exposure tests the drum was placed in the center of the 25 square foot ring.

In these tests all drums were filled five minutes prior to ignition with JP-4 as cargo. This was done to minimize the leaching of cargo into the drum walls. The filled and instrumented drum was placed as required and the JP-4 in the 25 square foot pan was ignited. Measurements were made until drum failure occurred and the fires were allowed to burn out. Each test was repeated three times and designated with an a, b, or c after the test number. The data for each test is presented in Appendix C.

4.1.1 Five-Gallon Blow-Molded Polyethylene Drums

Tests 1 and 2 were conducted with 5-gallon Specification 34 drums in the full and partial exposure positions respectively. From the tests, the following observations were made:

a. The drums failed when the sides burned, melted or softened causing a weakening of the drum wall and thus releasing cargo under head pressure only.

b. There was no detectable rise in cargo temperature or pressure.

c. The drums slowly collapsed into the fire and after failure burned like a candle until the fire went out.

d. The times to failure for these tests and comparative times from the Phase I tests are shown in Table 2.

If the low time in the 25 square foot full exposure tests is disregarded, an average time to failure of 00-41 is obtained. This would indicate a small increase in life when the fire exposure was lessened. Thus, the data does not seem to be conclusive. The drums in the 2-1/2 through 6-1/2 gallon range are required by 49 CFR 19.3(a) to have a minimum thickness of 0.045 inches and, therefore, are fairly thin-walled containers.

In this case, the size of the fire or amount of exposure has little effect on the failure times. In other words, any fire or any exposure sufficient to produce enough heat to weaken the walls to the point of failure, will cause cargo to be discharged and added to the fire.

TABLE 2

DATA SUMMARY FOR FAILURE OF POLYETHYLENE DRUMS

PHASE NUMBER	TEST NUMBER	FIRE AREA-EXPOSURE ft ²	DRUM CARGO	TIME TO FAILURE MIN:SEC	PHASE NUMBER	TEST NUMBER	FIRE AREA-EXPOSURE ft ²	DRUM CARGO	TIME TO FAILURE MIN:SEC
<u>5-GALLON BLOW-MOLDED</u>					<u>55-GALLON BLOW-MOLDED</u>				
I	1	90-FULL	JP-4	0:43	I	10	90-FULL	JP-4	1:42
	2			0:39		11			1:30
	3			0:24		12		JP-4	1:48
	17			0:48		29		ACETONE	1:30
	18			0:54		30			1:51
	19		JP-4	0:24	I	31	90-FULL	ACETONE	1:12
	20		ACETONE	1:18	II	7A	25-PART	JP-4	0:52
	21			1:17		7B			0:58
I	22	90-FULL	ACETONE	1:12		7C	25-PART		1:27
II	1A	25-FULL	JP-4	0:47		8A	25-FULL		1:19
	1B			0:34		8B			1:28
	1C	25-FULL		0:23		8C	25-FULL	JP-4	1:29
	2A	25-PART		0:37		10A	90-FULL	LUBE OIL	0:47
	2B			0:21		10B			1:00
II	2C	25-PART	JP-4	0:21		10C		LUBE OIL	0:51
<u>15-GALLON BLOW-MOLDED</u>						15A		ETHYL ETHER	1:09
I	4	90-FULL	JP-4	0:49		15B			1:23
	5			0:54	II	15C	90-FULL	ETHYL ETHER	1:20
	6		JP-4	1:00	<u>55-GALLON ROTATIONALLY-MOLDED</u>				
	23		ACETONE	2:17	I	13	90-FULL	JP-4	2:05
	24			1:57		14			2:36
I	25	90-FULL	ACETONE	1:54		15		JP-4	1:30
II	3A	25-PART	JP-4	1:21		32		ACETONE	3:14
	3B			1:58		33			2:36
	3C	25-PART		1:27	I	34	90-FULL	ACETONE	1:55
	4A	25-FULL		1:25					
	4B			1:12					
II	4C	25-FULL	JP-4	1:41					
<u>30-GALLON BLOW-MOLDED</u>									
I	7	90-FULL	JP-4	1:45					
	8			1:18					
	9		JP-4	1:18					
	26		ACETONE	2:12					
	27			1:42					
I	28	90-FULL	ACETONE	2:06					
II	5A	25-PART	JP-4	1:56					
	5B			2:01					
	5C	25-PART		1:31					
	6A	25-FULL		2:07					
	6B			0:19					
II	6C	25-FULL	JP-4	0:26					

4.1.2 Fifteen-Gallon Blow-Molded Polyethylene Drums

Tests 3 and 4 were conducted with 15-gallon Specification 34 drums in the partial and full exposure positions respectively. From the tests, the following observations were made:

a. The drums failed when the sides burned, melted or softened causing a weakening of the drum wall and thus releasing cargo under head pressure. Due to the larger size of these drums, observation of failure was easier. These drums tended to soften and fail in the lower one-third of the drum, below the rolling chime. The drum would then develop a very slow leak and discharge cargo into the fire. This failure would normally occur on the downwind side of the drum. Shortly after this leak developed, the remainder of the plastic would soften and the drum would fold into the fire on the downwind side. At this point, there would be a sharp increase in the fire intensity as the cargo rushed into the fire. Throughout the series, close observations of the plastic drums revealed small, intense fire eddy currents at the top and sides of the drums, where projections such as handles and rolling chimes were found. These currents were especially strong at the lower one-third on the downwind side of the drum.

b. There was no detectable rise in cargo temperature or pressure.

c. The time to failure for these tests are shown in Table 2.

e. The results using the thicker walled 15-gallon container (0.075 inches minimum thickness - 49 CFR 19.3(a)) showed a relationship between fire size, exposure, and drum life. In this case, the spread of average failure times is approximately half a minute between the 90 square foot and 25 square foot fire exposures. The trend appears to reverse itself between the full and partial exposure conditions of the 25 square foot fires. However, the individual data points overlap and so the trend is not significant. It does appear that these containers would give a longer time to failure with decreased exposure, but once again, any fire hot enough to soften the polyethylene would eventually cause failure and discharge of the cargo to the fire.

4.1.3 Thirty-Gallon Blow-Molded Polyethylene Drums

Tests 5 and 6 were conducted with 30-gallon Specification 34 drums in the partial and full exposure positions respectively. The 30-gallon drums used differed from those used in the Phase I tests primarily by a set of "tabs" attached to the top of the drum to facilitate handling. It is not believed that these additions would affect the time to failure. From the tests the following observations were made:

a. The drums failed when the sides burned, melted, or softened causing a weakening of the drum wall and thus releasing cargo under head pressure (Figure 5). A similar reaction as noted in 4.1.2(a) was observed with these drums. One drum fell over with a violent thud, caused by the failure of the downwind side and collapse of the drum with no prior leaking. This was the only drum of the six 30-gallon drums tested which did not fold gently into the fire.

b. There was no appreciable rise in cargo temperature or internal pressure. There was a detectable drop in pressure noted in Test 6 (full exposure) as the small failure in the lower area of the drum caused a vacuum to form for a short period.

c. The time to failure for these tests are shown in Table 2.

d. The 30-gallon drum seems at first glance to be inconsistent when compared to the others already discussed. By regulation (49 CFR 19.3(a)), the 30-gallon container must have a wall thickness of at least 0.125 inches. During the 25 square foot full exposure fires, the wind varied, with frequent direction changes at low velocities. This produced a fire which went straight up and was hotter than usual. This can be seen in the very even distribution of temperature in Channels 11-14 (see Appendix C). Once again the fire eddies were observed, however, the visual failure time on Test 6 was a delayed sighting due to the intense wall of flame obscuring the drum.

There is a spread of as much as one minute, thirty seconds, in failure times between drums exposed to the 25 square foot fires. The fastest failure was found in a smaller, more intense fire. Thus, it seems possible that a drum in a sheltered situation with only a very small fire could fail much faster than one in a large fire with an air movement.

4.1.4 Fifty-Five Gallon Blow-Molded Polyethylene Drums

Tests 7 and 8 were conducted with 55-gallon special permit drums in the partial and full exposure positions respectively. From the tests, the following observations were made:

a. The drums failed when the sides burned, melted, or softened causing a weakening of the drum wall and thus releasing cargo under head pressure. A similar reaction as noted in 4.1.2(a) was observed for these drums. The drums all failed on the downwind, hotter side, and folded into the fire.

b. There was no rise in cargo temperature or internal pressure noted.

c. The time to failure for these tests are shown in Table 2.

d. The reaction of the 55-gallon drum confirms that the heat generated by the fire is causing a surface melting and burning, while the cargo remains insulated. This would explain the fact that the liquid cargos have little effect on the plastic drum while greatly affecting the steel drum's fire resistance. The fire eddies were clearly visible during these tests and gases could actually be seen coming off the drum wall as melting took place.

4.1.5 Fifty-Five Gallon Steel Drums

Tests 11 and 12 were conducted with 55-gallon Specification 17E drums in the partial and full exposure positions respectively. From the tests, the following observations were made:

a. The drums failed by jetting, jetting then exploding, or exploding and releasing their cargos under pressure. Of the six drums in this series, three jetted to failure, two jetted then exploded, and one exploded.

b. The tendency during these tests was for the steel to tear at the most critical part of the roll, in this case the inside, exterior edge of the head or bottom chime roll. Four of the six drums tested exhibited this failure.

c. The time, cargo temperature, and pressure at failure for these tests and the Phase I tests are summarized in Table 3.

There was a very rapid heat rise on the downwind side of the drum during Test 11a not seen in the other tests. This heat in conjunction with a defect in the chime is believed to have caused the early failure.

4.2 Ninety Square Foot Full Exposure Fires With 55-Gallon Drums

In the Phase I tests, it was hypothesized that the time to failure of a steel drum is dependent on the volatility of the cargo while for a polyethylene drum it is independent of cargo volatility. In the case of steel drums, higher volatility is expected to produce shorter times to failure. To test this 90 square foot full exposure fire tests were conducted on 55-gallon drums containing various cargos. The cargos chosen were water, lubricating oil, JP-4, and ethyl ether which when compared with the results of the JP-4 and acetone tests conducted in Phase I give a good range of volatility.

In these tests the drums were placed in the center of the 90 square foot fire pan. The fire pan was fueled for all tests with JP-4. In all tests except the ethyl ether tests, the drums were filled within five minutes of ignition. The ethyl ether drums were filled within two hours of ignition. The water used for cargo was potable water. Data was recorded until drum failure occurred and the fires were allowed to burn out. Each test was repeated three times and designated with an a, b, or c after the test number. The data for each test is presented in Appendix D.



FIGURE 5

30-GALLON POLYETHYLENE DRUM COLLAPSING INTO 25 SQUARE FOOT PARTIAL EXPOSURE FIRE

TABLE 3

DATA SUMMARY FOR FAILURE OF 55-GALLON STEEL DRUMS

PHASE NUMBER	TEST NUMBER	FIRE AREA-EXPOSURE ft ²	DRUM CARGO	DATA AT INITIAL FAILURE				DATA AT FINAL FAILURE			
				TIME	PRESSURE	TEMPERATURE		TIME	PRESSURE	TEMPERATURE	
				MIN:SEC	PSIG	LIQUID °C	BUNG °C	MIN:SEC	PSIG	LIQUID °C	BUNG °C
SPECIFICATION 17E STEEL DRUMS											
I	16	90-FULL	JP-4					8:00	71 ^e	146	
	36		JP-4	4:30							
	37		ACETONE	1:25				2:47			
	38		JP-4	3:12	7.1	65		7:30	15 ^e	135	
	39			3:37				6:40			
	40			3:12	8.2	75		7:10	9.6 ^e	150	
I	41	90-FULL		6:18							
II	11A	25-PART		1:04	11.3	30	193	15:06	50 ^e	155	370
	11B			7:21	16.2	100	530				
	11C	25-PART						14:23	60 ^e	160	664
	12A	25-FULL		5:53	16.8 ^s	100	712				
	12B			5:24	18.3 ^s	100	411				
	12C	25-FULL	JP-4	6:29	14.9 ^s	95	646	10:58	59 ^e	150	916
	14A	90-FULL	LUBE OIL	2:39	6.8	220	646				
	14B			1:31	5.5	210	375				
	14C		LUBE OIL	1:14	7.2	230	648				
	17A		ETHYL ETHER	1:25	19.0	40	565	1:35	23	60	400
	17B			1:37	20.0	40	685	1:51	23	58	745
	17C		ETHYL ETHER	1:39	22.0	40	456	3:58	26	62	501
	13A		WATER	4:00	2.3	80					WERE NOT TESTED TO FAILURE
II	13B	90-FULL	WATER	16:00	25.3	135					BECAUSE FUEL BURNED OUT
SPECIFICATION 5B STEEL DRUMS											
II	16A	90-FULL	JP-4	4:05	55	105	508	6:21	17 ^e	150	645
	16B			5:47	62	135	712	6:08	64 ^e	140	748
	16C		JP-4	3:14	51	95	658	3:57	57		907
	18A		ETHYL ETHER	2:30	50	60	939				
	18B			0:56	14.4	20	519	2:25	54 ^e	60	621
II	18C	90-FULL	ETHYL ETHER	0:57	15.3	45	498	2:23	52 ^e		821
HYDROSTATIC TESTS WITH WATER											
			DRUM TYPE	PRESSURE RISE RATE PSIG/M							
I	42	17E	<40	4:00	70-75	23					METAL TORE-CHIME STRETCHED
II	20A	17E	16	4:30	72						BOTTOM SEAM UNCURLD
	20B	5B	16	7:45	124						METAL TORE AT BOTTOM SEAM
	20C	17E	80	0:56	75						BOTTOM SEAM UNCURLD
	20D	5B	80	0:34	45						SIDE WELD SPLIT
	20E	5B	80	1:31	126						METAL TORE AT BOTTOM SEAM
II	20F	17E	80	0:56	75	23					BOTTOM SEAM UNCURLD

NOTE: ^e indicates explosive failure^s indicates small jets

4.2.1 Blow-Molded Polyethylene Drums

Tests 9, 10, and 15 were conducted with 55-gallon blow-molded special permit polyethylene drums. The drum cargos were water, lubricating oil, and ethyl ether respectively. The results for each cargo follow and the data is listed in Table 2.

Water: From Test 9 the following observations were made:

- a. The drums failed as in previous polyethylene drum tests.
- b. There was no detectable rise in pressure or temperature in the drums.
- c. The water cargo entered the fire at essentially ambient temperature.

Lubricating Oil: From Test 10 the following observations were made:

- a. The method of drum failure was the same as in the previous polyethylene drum tests.
- b. There was no detectable rise in cargo temperature or pressure.
- c. The average failure times with this cargo remain close to those using other cargos.

Ethyl Ether: From Test 15 the following observations were made:

- a. The drums failed similar to all previous polyethylene drums.
- b. There was no detectable rise in cargo temperature or pressure.

4.2.2 Specification 17E Steel Drums

Tests 13, 14, and 17 were conducted with 55-gallon Specification 17E steel drums. The drum cargos were water, lubricating oil and ethyl ether respectively. The results for each cargo follow and the data is listed in Table 3.

Water: From Test 13 the following observations were made:

- a. The drums did not fail. The only damage was slight bulging on the ends. However, the fire burned out. Had it burned longer, it would be expected that the drum would have failed since the pressure was increasing.

b. The purpose of this test was to determine the amount of heat transfer to the cargo, when a steel drum is exposed to a fire. In the situation that was set up for these tests, the heat transfer was almost totally conductive. The cargo temperature and pressure rose in the tests as shown in Appendix D.

Lubricating Oil: From Test 14 the following observations were made:

a. The drums failed by jetting only. The cargos were released under low pressure and jets were maintained until the pan fire went out, whereupon the cargo cooled and the jet stopped.

b. In this section, one of the three drums tore open at the top chime, the remaining chimes unrolled.

c. The pressures at failure for the lube oil and the time to failure are less than was expected and are below the 15 psig called for in Specification 17E.

Ethyl Ether: From Test 17 the following observations were made:

a. The drums failed by jetting or jetting and then exploding. None of the three drums in this test failed by exploding only.

b. In two of the drums, the seam unrolled and tore at the outer edges. One drum unrolled for a distance of two inches while the rest of the head remained intact. The explosions seen with these were a violent jetting throwing cargo in a long thin flame. After the drum was burst open, the ether burned in a gentle continuous jet.

4.2.3 Specification 5B Drums

Tests 16 and 18 were conducted with 55-gallon Specification 5B steel drums. The drum cargos were JP-4 and ethyl ether respectively. The results for each cargo follow and the data is listed in Table 3.

JP-4: From Test 16 the following observations were made:

a. The drums failed by jetting or jetting and then exploding releasing their cargos under pressure. Of the three drums in this test, only one jetted to failure. In all three drums there was some torn metal present. In addition, the heads were distorted upward from three to six inches.

b. The distortion of the head was 6 inches in one case and this drum jetted to failure through a three-inch tear in the center of the head. In this case the reinforcing ring was distorted but held the head on the drum. The two remaining drums first jetted then exploded. The point of failure was again the head, but this time the chime unrolled most of the way. It tore the last two inches in one case and tore away for all but 12 inches in the other.

c. In the 90 square foot fires involving 17E drums, the average time to initial failure was 04-48 and for 5B drums it was 04-27. This may be somewhat misleading in that the personnel involved in this phase had the experience of the results of the first phase and, therefore, had some idea of what to look for. The "first jet" in these cases was a leakage of cargo caused by the burning away of gasketing in the rolled chime. The "second jet" was audible as well as visible and was obviously under pressure. This time is 04-58 for the 5B. This still shows no real fire safety advantage in using the 5B drum.

Ethyl Ether: From Test 18 the following observations were made:

a. The drums failed by jetting (Figure 6) or jetting and then exploding, releasing the cargo under pressure.

b. There were significant rises in pressure and temperature of the cargo.

c. Of the three drums, one jetted to failure while the other two jetted then exploded. The drum which jetted, did so so violently that it was at first considered an explosion. It was decided that this drum jetted when the head was found to have bulged eight inches and split six inches from the two-inch bung toward the center. The failure was similar to those seen when the drums had jetted. In the remaining two cases, the heads failed. In one case, the top unrolled and the head and reinforcing ring stayed together and in the other case, the head unrolled and completely separated.

4.3 Specification 5B Drum Array Test

Test Number 19 consisted of an array of 12 Specification 5B drums arranged in a closest-packed configuration and exposed to a 90 square foot fire. Both drum cargo and fuel were JP-4. From the test, the following observations were made:



FIGURE 6

JETTING FAILURE OF ETHYL OF ETHER IN A SPECIFICATION 5B DRUM EXPOSED TO A 90 SQUARE FOOT FIRE

a. Ten of the drums jetted to failure and two of them jetted and then exploded (Figure 7).

b. The drums did not leave the pad and there was little disturbance of the drums in the load.

c. All drums were distorted at their tops and bottoms, with the heads domed to as much as ten inches. Six of the drums had a two- to three-inch tear at the crown of the domed head. Two were unrolled and ripped at the head and the remaining four were slightly unrolled at the junction of the head and side body. No bottom failures occurred.

d. Table 4 gives results observed from a distance of 300 yards away. No instrumentation was used in this test due to the danger of damage to the instrumentation.

The fire in the pan and the cargo burned out at one hour and seven minutes. The fact that the drums covered approximately one-third of the surface of the 90 square foot pan kept the heat low and kept the drums cooler, limiting the number of explosions. This is a deduction from observed results which only instrumentation could confirm.

4.4 Hydrostatic Tests of Steel Drums

Test 20 consisted of three Specification 17E and three Specification 5B steel drums, which were subjected to hydrostatic tests to failure as outlined in Section 3.6. The basic setup for this test is shown in Figure 8 which shows a Specification 5B drum immediately prior to failing at the welded seam while undergoing a pressure rise of 80 psig per minute. Table 3 outlines the test results for all six drums.

Two of the Specification 5B drums failed the same (drums b and e) in spite of different rates of pressure rise. In both cases the bottom seam tore where the head and sides of the drum met. In both cases the rupture occurred close to the welded side seam. Figure 9 is a view of drum e (marked 5) after failure. The area where failure occurred is clearly marked. These drums failed at 124 and 126 psig respectively.

The third Specification 5B drum failed at the welded seam from a point at the upper rolling chime to a point 1/2 the way up to the head chime. This drum failed at 45 psig and was the only failure of this type throughout Phases I and II. This failure was probably due to a manufacturing defect.

All three of the Specification 17E drums failed identically and the pressures at failure were very similar. Drums a, c, and f (marked 1, 3, and 6 respectively) failed due to the unrolling of a bottom seam causing a jetting of the water. Figure 10 clearly demonstrates this failure.

From these tests, the following observations of drum reaction to pressure with both drum and cargo at ambient temperature can be made:



FIGURE 7
FAILURE DURING AN ARRAY TEST OF SPECIFICATION 5B DRUMS

TABLE 4

TIMES TO FAILURE FOR SPECIFICATION 5B DRUMS IN
AN ARRAY EXPOSED TO A 90 SQUARE FOOT FIRE

	<u>SMALL JET</u> <u>MIN:SEC</u>	<u>LARGE JET</u> <u>MIN:SEC</u>	<u>EXPLOSION</u> <u>MIN:SEC</u>
	1:35		
	2:00		
	3:19		
		3:41	
		4:07	
		6:16	
		6:51	
		8:34	
			31:05
			<u>31:07</u>
AVERAGE	<u>2:18</u>	<u>7:30</u>	<u>31:06</u>

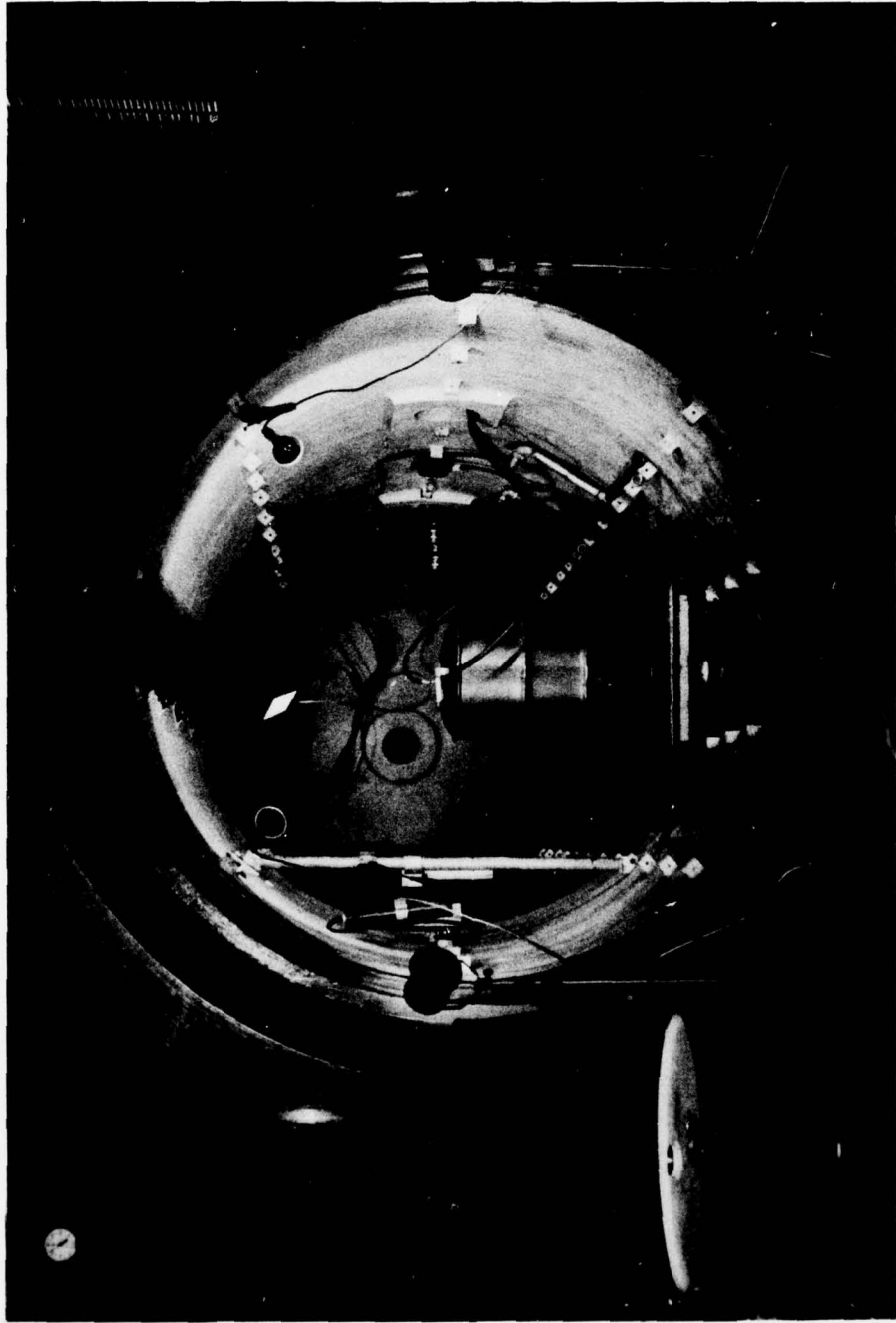

FIGURE 8
HYDROSTATIC TEST OF A SPECIFICATION 5B DRUM PRIOR TO FAILURE

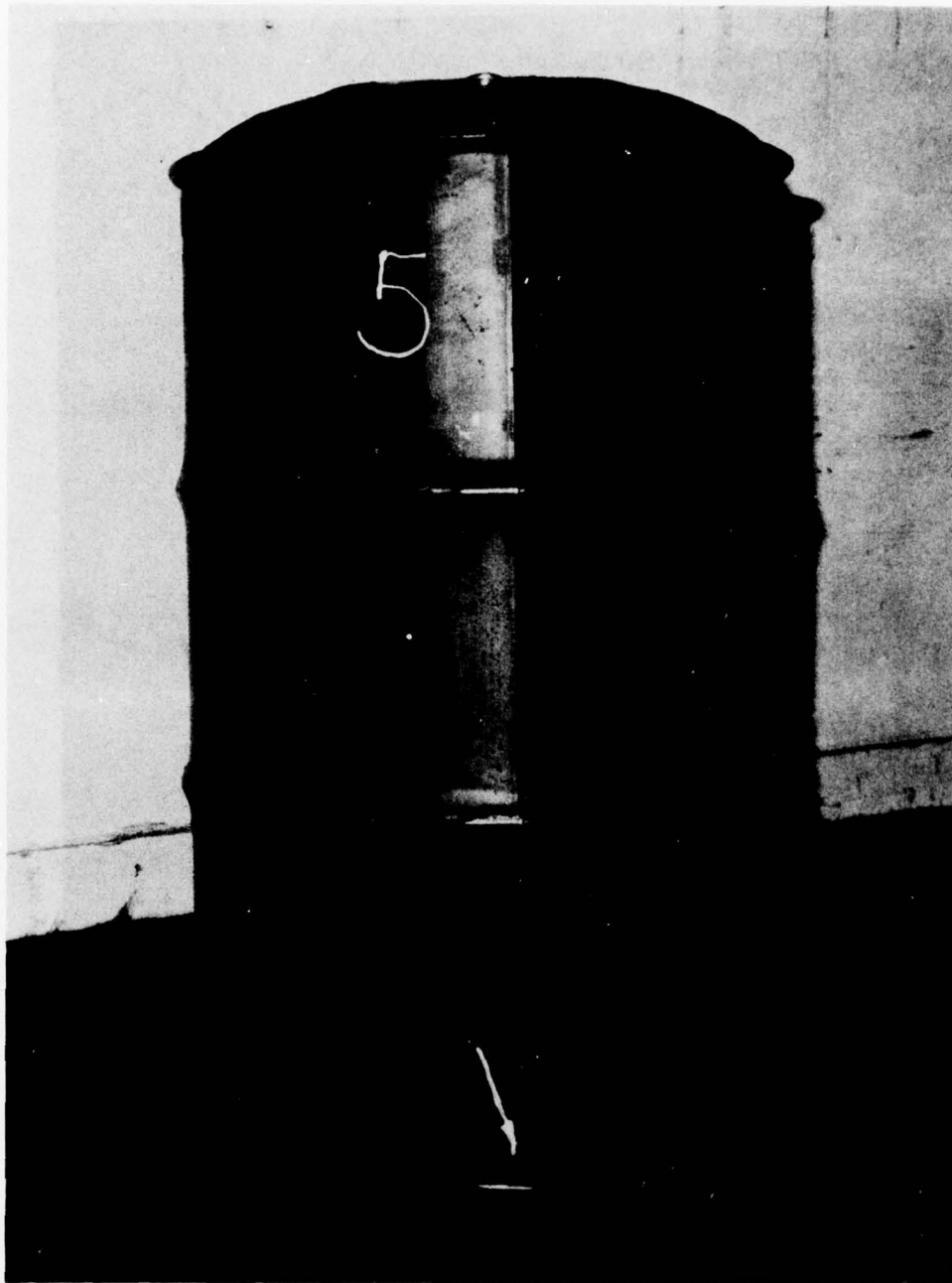

FIGURE 9

POINT OF FAILURE OF A SPECIFICATION 5B DRUM DURING HYDROSTATIC TESTS

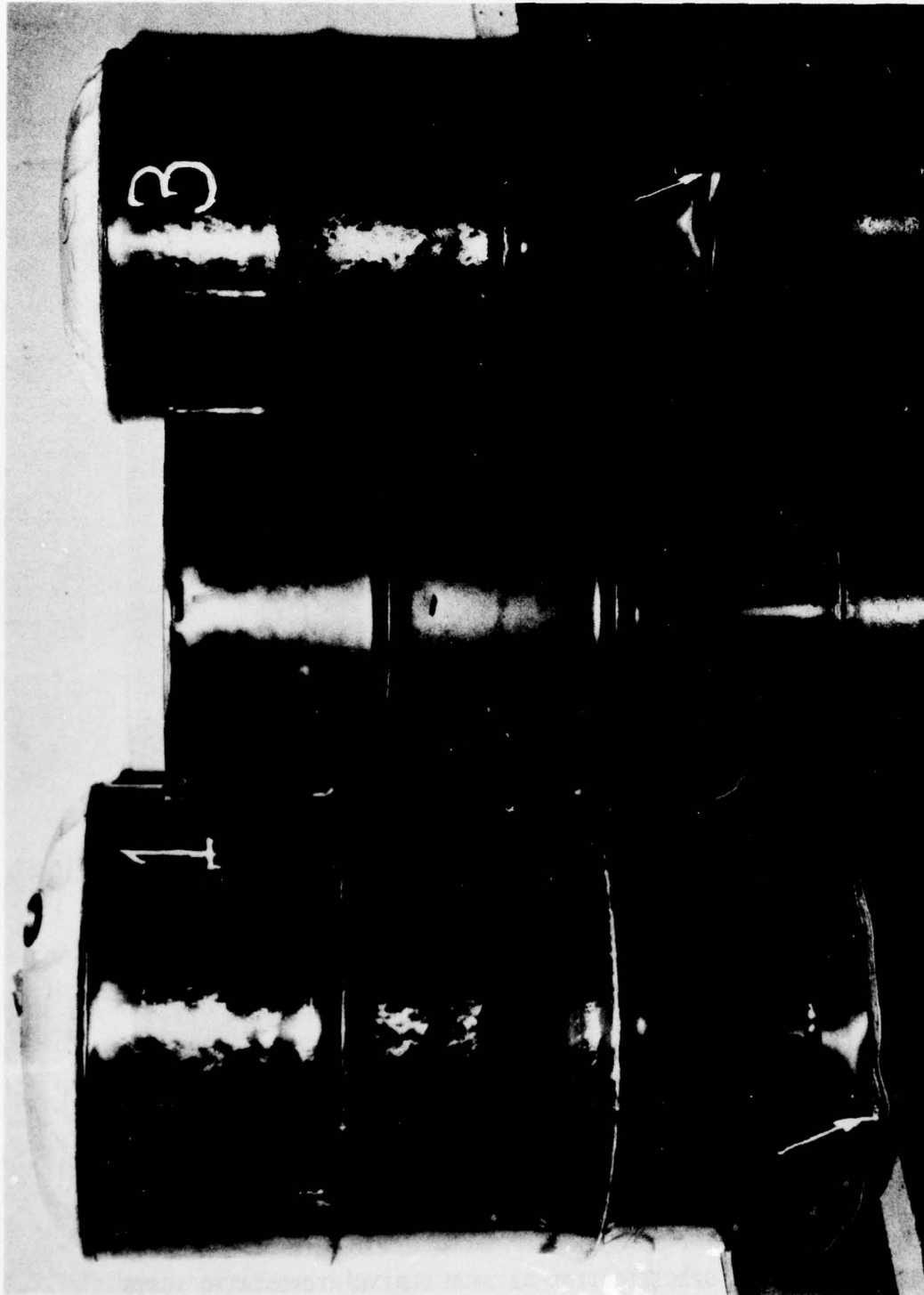

FIGURE 10

A SPECIFICATION 17E DRUM COMPARED TO TWO WHICH FAILED DURING HYDROSTATIC TESTS

a. Bottom failures tend to predominate with the double-rolled unreinforced bottom chimes of the 17E drums tending to unroll, and the reinforced, single-roll bottom chimes of the 5B tending to tear.

b. The pressure at failure for 17E drums is about 75 psig, and the rate of pressure rise does not seem to materially affect this.

c. The pressure at failure for 5B drums is about 125 psig, and the rate of pressure rise does not seem to materially affect this.

d. The failure modes noted in this series are similar to the ones noted in the fire tests. The failure times and pressures do not seem to correlate with those measured during the fire tests.

4.5 Data For Pressure-Relieving Devices

One of the points to be explored as part of these tests was the development of some criteria in order to design a device to relieve the internal pressure. Two devices were used to gather this data. The internal pressure of the drum was measured for all drums. For the steel drums one additional thermocouple was added on the two-inch bung, in order to record the temperatures at this point.

Table 3 gives a summary of the bung temperatures and the internal drum pressure at failure. Detailed bung temperature and internal drum pressure histories for each test can be found in Appendices C and D.

In all cases where there was failure except one, jetting occurred as the first sign of failure. The lowest temperature this occurred at was 193.1°C. The lowest pressure at failure was 5.5 psig, recorded during the lube oil tests. The seemingly non-related failure temperatures can be explained by the position of the two-inch bung and the wind direction and speed. If the wind forced the flame to lay over, less heat was seen at the point of measurement.

5.0 DISCUSSION

This discussion of the testing is divided into the effects that the various parameters had on the fire. The size of the fire which impinged on the drum, the fire exposure, was one of the principle effects investigated. The effect of drum cargo on time to failure was also investigated. These effects will be discussed and the section will conclude with a discussion comparing drum type and construction.

5.1 Effects of Fire Exposure

The effects of fire exposure were examined by comparing the times to failure for the various drums when exposed to successively larger fires. The smallest fire was 25 square feet with partial exposure (i.e., approximately 50 percent of the drums verticle surface area). The larger fires included 25 square foot and 90 square foot full exposure fires. The data for the comparison is summarized in Table 5.

An examination of this data shows that there is not a significant decrease in the time to failure with increasing fire size for the polyethylene drums. This is best understood by examining the failure modes for the plastic drums. In all cases they softened, burned, or melted until they breached. This mode can be caused by a localized hot flame as well as a large fire which completely engulfs the drum. The only difference in these two cases is in the total heat applied to the drum. Since melting is a localized phenomena then the result is understandable. It is also interesting to note the general increase in failure time with increased polyethylene thickness. This is to be expected since the melting time of a plastic is a function of its thickness.

There is no logical order to the average times to failure for Specification 17E 55-gallon steel drums listed in Table 5. Further, as indicated the data which makes up these averages is widely scattered. It appears that the integrity of the drum and the care with which it was manufactured is more important than the size of the fire exposure. Failure of steel drums appears to be caused by overall forces instead of the localized melting experienced for the plastic drums. In general, the pressure builds within the steel drum until the weakest point fails. The weakest point can be a result of any of several steps in the manufacturing process. These random causes result in variable times to failure.

5.2 Effects of Drum Cargo

The cargos were chosen to give a range of volatility since this parameter was expected to affect drum failure. The heat capacities were also expected to have an effect on the rate which pressure increased in the drums and the thermal expansion of the liquid could have a marked effect once the liquid had filled the slack space in the top of the drum. While all of these properties are interrelated the test results did not permit discrimination to the point where any one factor could be singled out as the prime contributor.

TABLE 5

AVERAGE TIME TO FAILURE FOR INCREASING EXPOSURES OF DRUMS TO JP-4 FIRES

DRUM TYPE	AVERAGE TIME TO FAILURE (MIN:SEC)			
	25 ft ² PARTIAL EXPOSURE	25 ft ² FULL EXPOSURE	90 ft ² FULL EXPOSURE	90 ft ² FULL EXPOSURE*
<u>POLYETHYLENE DRUMS</u>				
5-Gallon Blow-Molded	0:26	0:35		0:39
15-Gallon Blow-Molded	1:58	1:26		0:54
30-Gallon Blow-Molded	1:49	DATA SCATTERED		1:27
55-Gallon Blow-Molded	1:06	1:25		1:40
<u>STEEL DRUMS - 55-GALLON</u>				
Specification I7E	4:13**	5:55**		4:48**

*Data Taken From Phase I Report¹

**Wide Scatter in Data

The effects of drum cargo on 55-gallon blown polyethylene drums were examined by comparing the times to failure from Table 2 of the drums loaded with the different cargos and exposed to a 90 square foot fire. It was found that the failure times range from 47 to 108 seconds, that lower times are found for ethyl ether and lube oil, and that higher times are found for JP-4 and acetone. Since ethyl ether and lube oil represent the extremes in volatility the fact that low failure times are found for both is suspect. A possible reason for these low times is that they were taken during the Phase II testing when the observers knew what to look for. It is believed that the cargo in polyethylene drums has no significant effect on the time to failure which is to be expected because temperature/melting not internal drum pressure is the cause of failure.

The effects of drum cargo on 55-gallon Specification 17E steel drums could not be determined by comparing times to failure. The randomness of the failure pressure made such a comparison meaningless. The rates of pressure rise in the drums were examined. This indicated that the pressure was rising more rapidly for ethyl ether (approximately 12 psig/min over the first 2 minutes) than for JP-4 (approximately 3.5 psig/min over the first 2 minutes) or lube oil (approximately 3.0 psig/min over the first 2 minutes). The data for acetone was not complete. Since the steel drums fail by bursting due to increased pressure, it is obvious that the cargo does have an effect on the failure time. If the drums were made and loaded identically, we would expect the drum loaded with a highly volatile cargo such as ethyl ether to fail before the one filled with a cargo of lower volatility.

5.3 Effects of Drum Type/Construction

The drum types were chosen to represent those currently approved and used in shipping chemicals. The drum type which is used for shipment of a particular chemical is industry's choice provided regulation guidelines are followed. Their choice is based usually on such considerations as cost per drum, drum/chemical compatibility, and handling considerations. These tests indicate that still another consideration might be the fire resistance and failure mode of the drums.

Polyethylene drum failure is reasonably easy to predict. It is a function of wall thickness and the localized heat applied to that wall. For the drums currently approved and tested failure generally occurs after about 1-1/2 minutes of fire exposure. Failure is caused by the melting of a portion of the drum and the emptying of the drum contents into the fire. This process occurs over several seconds and, therefore, does not significantly increase the severity of the fire. It will, of course, prolong the burning time of the fire if extinguishment is not accomplished.

The failure of a steel drum is much more difficult to predict. Failure is caused by a pressure increase in the drum. While it was not determined from the data gathered whether the pressure was created by expansion of the liquid or the vapor pressure of the liquid, it was pressure that ruptured the drums. As seen from the data in Table 3, the pressure at failure

varied from 5.5 to 71 psig for Specification 17E drums and 14.4 to 64 psig for Specification 5B drums. This scatter indicates inconsistencies in drum integrity. These inconsistencies must be a result of poor quality control or procedures during the manufacturing process since these drums were bought new and shipped empty to the test site. It is these inconsistencies which make the pressure and thus the time to failure difficult to predict.

If we examine the time to failure for Specification 17E drums which initially failed at a pressure greater than 15 psig (chosen because that is the specification test pressure) we see that a significant amount of time is available before failure of drums with JP-4 cargo. This time can be used to bring the fire under control. Applying the same criteria to Specification 17E drums with ethyl ether cargo, we find about the same time to failure as in a polyethylene drum (i.e., 90 seconds). In the one case where the Specification 5B drum failed at 40 psig or greater (chosen because that is the specification test pressure) with ethyl ether as cargo, the time to failure was somewhat longer (i.e., 150 seconds). The remaining Specification 5B drums failed in times which were similar to the 17E drum failure times.

Thus, the principle effect of drum type is that steel will provide a longer time to failure than polyethylene when the drums are exposed to a fire and loaded with a cargo in the volatility range of JP-4. When the drums are loaded with cargoes as volatile as ethyl ether the time to failure is very similar for steel and polyethylene drums. Another effect of drum type is that polyethylene will fail in a slow, controlled manner where steel will fail in a more violent jet or explosion.

6.0 CONCLUSIONS

1. Polyethylene drums fail by localized melting and collapsing into the fire. The size of the fire does not significantly affect the failure rate over the 25 to 90 square foot range tested. The volatility of the cargo in 55-gallon drums has no significant effect on the time to failure which ranges between 1 and 1-1/2 minutes.

2. Specification 17E steel drums fail when the internal pressure causes them to burst. This can take the form of a jet of fire or an explosion which blows the entire top or bottom of the drum out. The effects of the size of the fire could not be determined because of inconsistencies in drum manufacture. These inconsistencies permitted several drums to fail below the specification test pressure. An increase in the drum cargo volatility was found to produce a decrease in the time to failure as previously reported.

3. Similar results were found for Specification 5B drums in terms of time to failure. This was surprising as the 5B drum is considered a higher integrity drum. They did contain higher pressures up to the time at which they failed.

4. The most striking result is that all drums (17E, 5B, and polyethylene) loaded with ethyl ether failed on the average within 17 seconds of each other in a fire. By contrast, the steel drums loaded with JP-4 or lube oil provided approximately 4 minutes more time than polyethylene drums before failure in a fire. This suggests that the polyethylene drums should be used with volatile flammable liquids because of their noncatastrophic failure modes and steel drums should be used for less volatile flammable liquids because they provide enough time before failure to permit fire extinguishment.

APPENDIX A

Specifications for 5, 15, and 30 gallon polyethylene drums (Spec 34), 55 gallon steel drums (Spec 17E), and 55 gallon steel drums (Spec 5B), Title 49, Code of Federal Regulations.

§ 178.19 Specification 34; reusable molded polyethylene container for use without overpack. Removable head not authorized.

[Order 71, 31 F.R. 9073, July 1, 1966]

§ 178.19-1 Compliance.

(a) Required in all details.

[Order 71, 31 F.R. 9073, July 1, 1966]

§ 178.19-2 Material.

(a) Containers shall be made of polyethylene which shall have the following properties, as determined by the American Society for Testing Materials (ASTM) methods designated. Tests shall be performed on resin with additives included:

Property	Specification	ASTM method
Melt index.....	1.2 maximum.....	D 1228 (62T).
Density range.....	0.941-0.965.....	D 1505 (63T).
Tensile strength....	3,000 p.s.i. minimum.	D 638 (61T).
Percent elongation.	75 percent minimum.	D 638 (61T).

(b) Ultraviolet light protection shall be provided by impregnation of polyethylene with carbon black or other equally efficient pigments or inhibitors. These additives must be compatible with lading and must retain their effectiveness for the life of the container.

(c) Other materials may be added provided they do not adversely affect the physical properties specified in paragraph (a) of this section or the performance specified in § 178.19-7.

[Order 71, 31 F.R. 9073, July 1, 1966]

§ 178.19-3 Construction and capacity.

(a) Container must be constructed in accordance with the following table:

Marked (rated) capacity not over (gallons) ¹	Minimum thickness (inches) measured on any point of container
3½ thru 6½.....	0.045
15075
30125

¹ Minimum actual capacity shall not be less than rated capacity plus 4 percent. Maximum actual capacity shall not be greater than rated capacity plus 15 percent for containers up to 15 gallons and shall not be greater than rated capacity plus 10 percent for containers 15 gallons and over.

[Order 71, 31 F.R. 9073, July 1, 1966]

§ 178.19-4 Closure.

(a) Openings shall not exceed 2.7 inches in diameter.

(b) Closures shall be of material resistant to lading and adequate to prevent leakage under tests prescribed in § 178.19-7 and under conditions incident to transportation.

(c) Vented closures where specified in Part 173 of this chapter are authorized

[Order 71, 31 F.R. 9073, July 1, 1966]

§ 178.19-5 Defective containers.

(a) Containers with repaired bodies not authorized.

[Order 71, 31 F.R. 9073, July 1, 1966]

§ 178.19-6 Marking.

(a) Each container must be permanently marked by embossment in letters and figures at least ½ inch in size as follows:

(1) DOT-34**; stars to be replaced by the rated capacity of the container (for example, DOT-34-5). These marks shall be understood to certify that the container complies with all specification requirements.

(2) Month and year of manufacture; name of maker or maker's symbol (symbol, if used, must be registered with the Bureau of Explosives). For example, DOT-34-5-6/65 to indicate a container of 5 gallons capacity made in June 1965. [Order 71, 31 F.R. 9073, July 1, 1966]

§ 178.19-7 Tests.

(a) At least three samples taken at random, filled and prepared as specified and closed as for use, shall be capable of withstanding the tests in subparagraphs (1), (2), and (3) of this paragraph without leakage. These tests shall be performed at the start of initial production and at 4-month intervals and shall be repeated on any change of type, size, materials, or process method. No single container shall be expected to withstand more than one of the following tests:

(1) The container filled to 98 percent capacity with water shall be dropped from a height of 4 feet onto solid concrete so as to drop diagonally on top edge or any part constructed to a lesser strength.

(2) The container filled to 98 percent capacity with a solution compatible with polyethylene and which remains liquid at 0° F. shall be dropped from a height of 4 feet onto solid concrete on any part of the container when container and contents are at or slightly below 0° F. Filled container shall be stored at 0° F. or lower temperature for at least 4 hours immediately preceding test.

(3) The container shall be tested by retaining for 5 minutes hydrostatic pressure of at least 15 pounds per square inch at equilibrium without showing pressure drop or evidence of leakage.

(b) At least three containers taken at random from each continuous production lot of no more than 1,000 containers of each given type and size shall withstand without leakage or failure the test prescribed in § 178.19-7(a)(2).

(c) At least three containers of each size and type taken at random at start of initial production, and upon any change in materials, design, or process method shall withstand without failure or leakage the following tests. No single container shall be expected to withstand more than one test:

(1) The container filled to 98 percent of capacity with water shall be capable of withstanding a vibration test by plac-

ing the container on the vibration table anchored in such manner that all horizontal motion shall be restricted and only vertical motion allowed. The test shall be performed for one hour using an amplitude of one inch at a frequency that causes the test container to be raised from the floor of the table to such a degree that a piece of paper or flat steel strap or tape can be passed between the table and the container.

(2) The container filled to 98 percent capacity with water shall withstand the following static compression test without buckling of the side walls sufficient to cause damage, but in no case shall the maximum top to bottom deflection be more than one inch. Compression shall be applied to the load bearing areas of the top of the container for a period of not less than 48 hours.

Marked (rated) capacity (gallons)	Compression test (pounds)
2½ thru 6½	600
15	1,200
30	1,800

(d) Records of test results to be maintained in current status and retained by each manufacturer at each producing plant.

[Order 71, 31 F.R. 9073, July 1, 1966]

§ 178.116 Specification 17E; steel drums.

Single trip container. Removable head containers not authorized.

§ 178.116-1 Compliance.

(a) Required in all details.

§ 178.116-2 Rated capacity.

(a) Rated capacity as marked, see § 178.116-10(a)(3). Minimum actual capacity of containers shall be not less than rated (marked) capacity plus 4 percent. Maximum actual capacity shall not be greater than rated (marked) capacity plus 5 percent or rated (marked) capacity plus 4 percent plus 1 quart whichever is the greater.

§ 178.116-3 Composition.

(a) Sheets for body and heads to be low carbon, open hearth or electric steel.

§ 178.116-5 Seams.

(a) Body seams welded.

§ 178.116-6 Parts and dimensions.

(a) Parts and dimensions as follows:

Marked capacity not over (gallons)	Type of container	Minimum thickness, uncoated sheets (gauge)		Rolling hoops		
		Body sheet	Head sheet	Type	Minimum	
					Size (gauge or inch)	Weight (pounds per foot)
5	Straight side	24	24	None		
10	do	22	22	do		
30	do	19	19	(1)		
55	do	18	18	(1)		

¹ Rolled or swaged in hoops.
² 20 gauge authorized.

(b) Steel sheets of specified gauges shall comply with the following:

Gauge No.	Nominal thickness ¹ (inch)	Minimum thickness ¹ (inch)
18	0.0478	0.0428
19	.0418	.0378
20	.0359	.0324
22	.0299	.0269
24	.0239	.0209

¹ Thickness shall be measured at any point on the sheet not less than 3/8 inch from an edge.
 [29 FR 18893, Dec. 29, 1964. Redesignated at 32 FR 5606, Apr. 5, 1967 and amended by Amdt. 178-31, 39 FR 10910, Mar. 22, 1974; 39 FR 11891, Apr. 1, 1974]

§ 178.116-7 Convex heads.

(a) Convex (crowned) heads, not extending beyond level of chime, required for drums of 25 gallons capacity or over. Convexity to be minimum of 3/8".

§ 178.116-8 Closures.

(a) Adequate to prevent leakage; gaskets required.

(b) Closing part (plug cap plate etc., see Note 1) must be of metal as thick as prescribed for head of container: *Provided*, That thinner metal closures or closures of other material are authorized for containers of 12 gallons capacity or less when opening to be closed is not over 2.7 inches in diameter and closures, except threaded metal closures, are fitted with outside sealing devices which cannot be removed without destroying the closure or sealing device (see paragraph (d) of this section).

NOTE 1: This does not apply to cap seal over a closure which complies with all requirements.

(c) For closure with threaded plug or cap, the seat (flange, etc.) for plug, or cap, must have 3 or more threads; two drainage holes of not over 1/16 inch diameter are allowed. Plug, or cap, must have sufficient length of thread to engage 3 threads when screwed home with gasket in place: *Provided*, That for containers having a capacity of 12 gallons and less the seat (flange, etc.) for plug, or cap, must have two or more complete threads and plug, or cap, must have sufficient length of thread to engage two threads when screwed home with gasket in place.

(d) Closures of screw-thread type or closed by positive means, of any material or design, may be authorized by the Bureau of Explosives for use, upon satisfactory proof of efficiency.

§ 178.116-9 Defective containers.

(a) Leaks and other defects to be repaired by method used in constructing container, not by soldering.

§ 178.116-10 Marking.

(a) Marking on each container by embossing on head with raised marks, or by embossing or die stamping on footing on drums equipped with foot-rings, or on metal plates securely attached to drum by brazing or welding not less than 20 percent of the perimeter as follows:

(1) DOT-17E. The letters STC; located near the DOT mark to indicate "single-trip container." In addition, when the container is of stainless steel, the type of steel used in body and head

sheets as identified by American Iron and Steel Institute type number, and also the letters HT following steel designation on containers subjected to stress-relieving or heat-treatment during manufacture (for example, DOT-17E-304 or DOT-17E-304 HT as applicable) shall be shown. These marks shall be understood to certify that the container complies with all specification requirements.

(2) Name or symbol (letters) of maker; this must be recorded with the Bureau of Explosives.

(3) Gauge of metal in thinnest part, rated capacity in gallons, and year of manufacture (for example, 12-55-50). When gauge of metal in body differs from that in head, both must be indicated with slanting line between and with gauge of body indicated first (for example 14/12-55-50 for body 14 gauge and head 12 gauge).

[29 F.R. 18893, Dec. 29, 1964, as amended by Order 66, 30 F.R. 5755, Apr. 23, 1965]

§ 178.116-11 Size of markings.

(a) Size of markings (minimum): $\frac{1}{2}$ " high for 33-gallon or less, $\frac{3}{4}$ " for over 33 and not over 55 gallons.

§ 178.116-12 Type tests.

(a) Samples taken at random and closed as for use, shall withstand prescribed tests without leakage. Tests to be made of each type and size by each company starting production and to be

repeated every 4 months. Samples last tested to be retained until further tests are made or for 1 year, whichever period is shorter. The type tests are as follows:

(1) Test by dropping, filled with water to 98 percent capacity, from height of 4 feet onto solid concrete so as to strike diagonally on chime, or when without chime seam, to strike on other circumferential seam; also additional drop test on any other parts which might be considered weaker than the chime. Closing devices and other parts projecting beyond chime or rolling hoops must also be capable of withstanding this test.

(2) Hydrostatic pressure test of 15 pounds per square inch sustained for 5 minutes.

[29 F.R. 18893, Dec. 29, 1964, as amended by Order 66, 30 F.R. 5755, Apr. 23, 1965]

§ 178.116-13 Leakage test.

(a) Each container shall be tested, with seams under water or covered with soapsuds or heavy oil, by interior air pressure of at least 7 pounds per square inch for containers over 12 gallons capacity and at least 5 pounds for others. Equally efficient means of testing are authorized upon demonstration and proof of satisfactory tests to representative of Bureau of Explosives. Leakers shall be rejected or repaired and retested

§ 178.82 Specification 3B; steel barrels or drums.

Removable head containers which will pass all required tests are authorized.

§ 178.82-1 Compliance.

(a) Required in all details.

§ 178.82-2 Rated capacity.

(a) Rated capacity as marked, see § 178.82-11(a)(3). Minimum actual capacity of containers shall be not less than rated (marked) capacity plus 4 percent. Maximum actual capacity shall not be greater than rated (marked) capacity plus 5 percent or rated (marked) capacity plus 4 percent plus 1 quart whichever is the greater. Actual capacity of bilge type containers must be not less than rated (marked) capacity, nor greater than rated (marked) capacity plus 2 percent plus 2 quarts.

§ 178.82-3 Composition.

(a) Sheets for body and heads to be low carbon, open hearth or electric steel.

§ 178.82-5 Seams.

(a) Body seams welded.

§ 178.82-6 Chime reinforcement.

(a) Containers over 25 gallons capacity, with flanged head secured to body, to have chime reinforcement adequate for its protection.

(b) Steel sheets of specified gauges shall comply with the following:

Gauge No.	Nominal thickness ¹ (inch)	Minimum thickness ¹ (inch)
13	0.0897	0.0817
14	.0747	.0677
16	.0598	.0533
19	.0478	.0428
20	.0359	.0324
22	.0294	.0269
24	.0239	.0209

¹ Thickness shall be measured at any point on the sheet not less than 1/8 inch from an edge.

§ 178.82-8 Rolling hoops.

(a) Separate hoops to have tight fit on shell and be firmly secured in place. Beading under rolling hoops or spot welding not permitted.

§ 178.82-9 Closures.

(a) Adequate to prevent leakage; gaskets required.

(b) Closing part (plug, cap, plate, etc., see Note 1) must be of metal (see

§ 178.82-7 Parts and dimensions.

(a) Parts and dimensions as follows:

Marked capacity not over (gallons)	Type of container	Minimum thickness, uncoated sheets (gauge)		Rolling hoops		
		Body sheet	Head sheet	Type ¹	Minimum	
					Size (gauge or inch)	Weight (pounds per foot)
5	Straight side	24	7	One		
10	do	22	25	do		
15	do	20	20	(2)		
20	do	18	18	(3)		
25	do	16	16	(4)		
30	do	14	14	(5)		
35	do	12	12	(6)		
40	do	10	10	(7)		
45	do	8	8	(8)		
50	do	6	6	(9)		
55	do	4	4	(10)		
	Bilge	16	16	None		
	do	14	14	do		

¹ Rolling hoops of pliable solid rubber or other suitable material are also authorized when approved as to type and construction by the Bureau of Explosives.

² Rolled or swaged in hoops.

³ Each removable head drum body must have three rolled or swaged in hoops with the center-line of one not more than 4 inches from the top curl.

paragraph (c) of this section) as thick as prescribed for head of container; this not required for containers of 12 gallons or less when the opening to be closed is not over 2.7 inches in diameter. If unthreaded cap is used it must be provided with outside sealing devices which cannot be removed without destroying the cap or sealing device.

Note 1: This does not apply to cap seal over a closure which complies with all requirements.

(c) For closure with threaded plug or cap, the seat (flange, etc.) for plug, or cap, must have 3 or more complete threads; two drainage holes of not over 1/8 inch diameter are allowed. Plug, or

cap, must have sufficient length of thread to engage 3 threads when screwed home with gasket in place. Closures of screw-thread type or closed by other positive means, of any material or design, may be authorized by the Bureau of Explosives for use, upon satisfactory proof of efficiency.

(d) Full removable head drums over 5 gallons capacity must be closed by means of 12 gauge bolted ring with drop forged lugs, one of which is threaded, and having 3/8 inch bolt and nut for drums not over 30 gallons capacity and 1/2 inch bolt and nut for drums over 30 gallons capacity. Five gallon drums must be of lug type closure with cover having at least 16 lugs. Equally efficient types of closures are authorized upon demonstration and proof of satisfactory tests to representative of Bureau of Explosives.

[29 F.R. 18893, Dec. 29, 1964, as amended by Order 87, 30 F.R. 7425, June 5, 1965]

§ 178.82-10 Defective containers.

(a) Leaks and other defects to be repaired by method used in constructing container, not by soldering.

§ 178.82-11 Marking.

(a) Marking on each container by embossing on head, except that such embossment must be on the permanent head for drums having removable heads, with raised marks, or by embossing or die stamping on footing on drums equipped with footings, or on metal plates securely attached to drum by bracing or welding not less than 20 percent of the perimeter, as follows:

(1) DOT-5B. In addition, when the container is of stainless steel, the type of steel used in body and head sheets as

identified by American Iron and Steel Institute type number, and also the letters HT following steel designation on containers subjected to stress relieving or heat treatment during manufacture. (for example, DOT-5B-304, or DOT-5B-304 HT as applicable), shall be shown. These marks shall be understood to certify that the container complies with all specification requirements.

(2) Name or symbol (letters) of maker; this must be recorded with the Bureau of Explosives.

(3) Gauge of metal in thinnest part, rated capacity in gallons, and year of manufacture (for example, 14-55-50). When gauge of metal in body differs from that in the head, both must be indicated with slanting line between and with gauge of body indicated first (for example 14/12-55-50 for body 14 gauge and head 12 gauge).

[29 F.R. 18893, Dec. 29, 1964, as amended by Order 66, 30 F.R. 5752, Apr. 23, 1965]

§ 178.82-12 Size of markings.

(a) Size of markings (minimum): $\frac{1}{2}$ " high for 33-gallon or less, $\frac{3}{4}$ " for over 33 and not over 55 gallons, and 1" for over 55 gallons.

§ 178.82-13 Type tests.

(a) Samples taken at random and closed as for use, shall withstand prescribed tests without leakage. Tests to be made of each type and size by each company starting production and to be repeated every 4 months. Samples last tested to be retained until further tests are made or for 1 year, whichever period is shorter. The type tests are as follows:

(1) Test by dropping, filled with water to 98 percent capacity, from height of 4 feet onto solid concrete so as to strike diagonally on chime, or when without chime seam, to strike on other circumferential seam; also additional drop test on any other parts which might be considered weaker than the chime. Closing devices and other parts projecting beyond chime or rolling hoops must also be capable of withstanding this test.

(2) Hydrostatic pressure tests of 40 pounds per square inch sustained for 5 minutes; except that full removable head drums must sustain 20 pounds per square inch.

[29 F.R. 18893, Dec. 29, 1964, as amended by Order 66, 30 F.R. 5752, Apr. 23, 1965]

§ 178.82-14 Leakage test.

(a) Each container shall be tested, with seams under water or covered with

soapsuds or heavy oil, by interior air pressure of at least 15 pounds per square inch. Equally efficient means of testing are authorized upon demonstration and proof of satisfactory tests to representative of Bureau of Explosives. Leakers shall be rejected or repaired and retested. Removable head containers not required to be tested with heads in place except that samples taken at random and closed as for use, of each type and size, must be tested at start of production and repeated every 4 months. Samples last tested to be retained until further tests are made or for 1 year, whichever period is shorter.

[Order 66, 30 F.R. 5752, Apr. 23, 1965]

Appendix B: Information on drums used in these tests.

1. 5 Gallon, Blow Molded, Polyethylene Drum.

Supplier: Harley Corporation, P.O. Box 5497,
Spartanburg, S.C.

Construction: One piece, blow molded of high
density polyethylene.

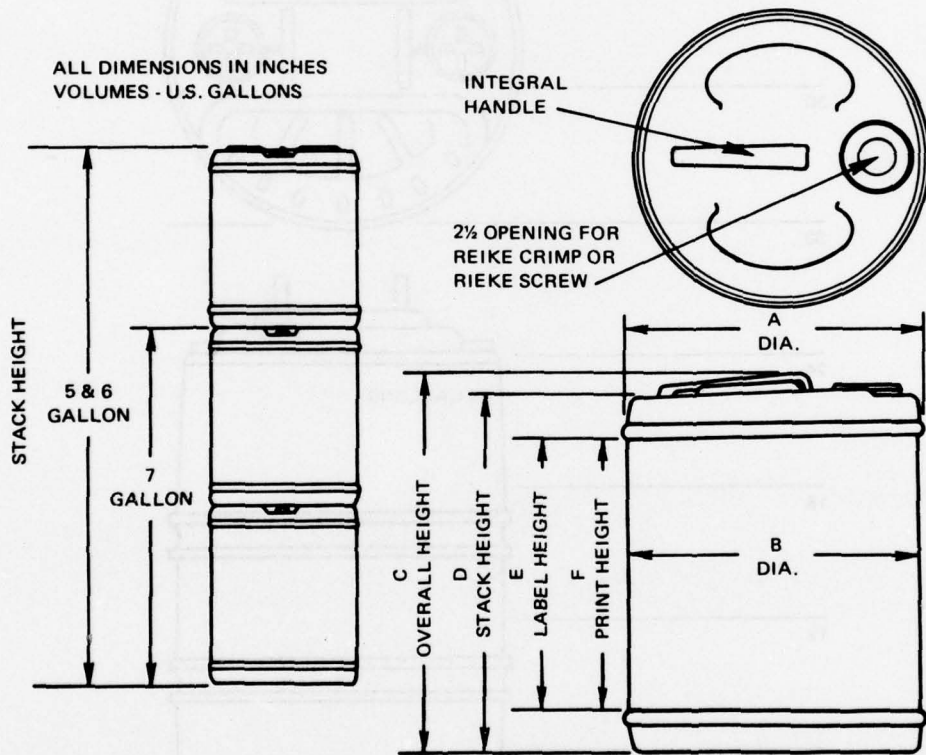

SIZE	A	B	C	D	E	F	STACK HEIGHT
5 GAL.	11 23/32	11 1/2	14 3/4	14 1/8	10 1/8	9	43

2. 15 Gallon, Blow Molded, Polyethylene Drums.

Supplier: Container Corporation of America, 1205 E. 12th Street, Wilmington, Del.

Construction: One piece, blow molded of high density polyethylene.

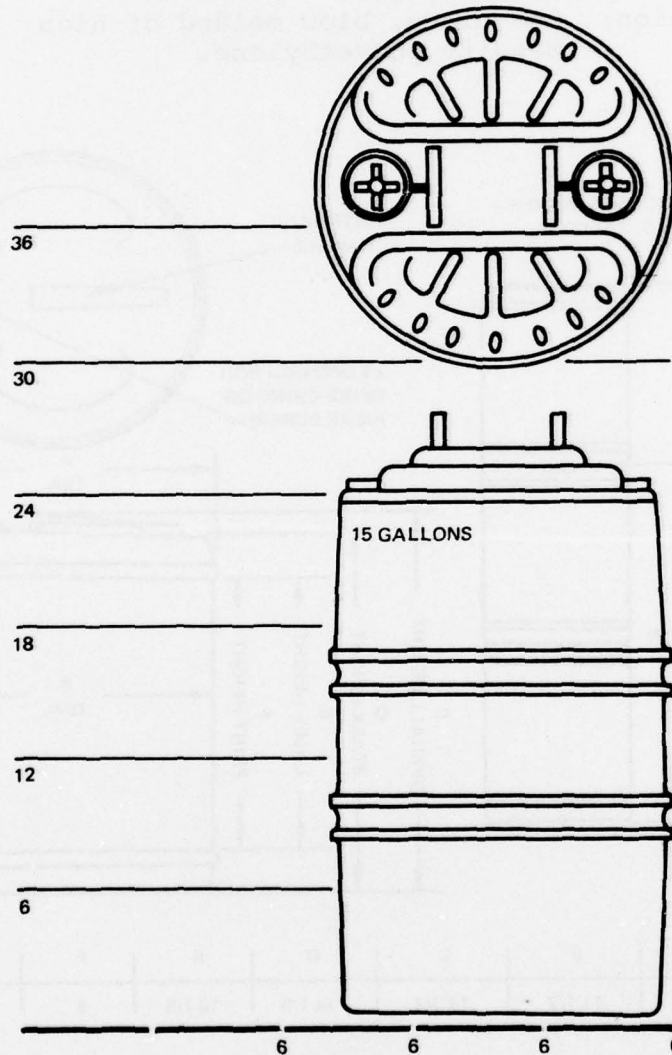

DIMENSIONS

"ALL DIMENSIONS ARE NOTED APPROXIMATE IN INCHES."

3. 30 Gallon, Blow Molded, Polyethylene Drum

Supplier: Harley Corporation, P.O. Box 5497,
Spartanburg, SC

Construction: One piece blow molded of high
density polyethylene.

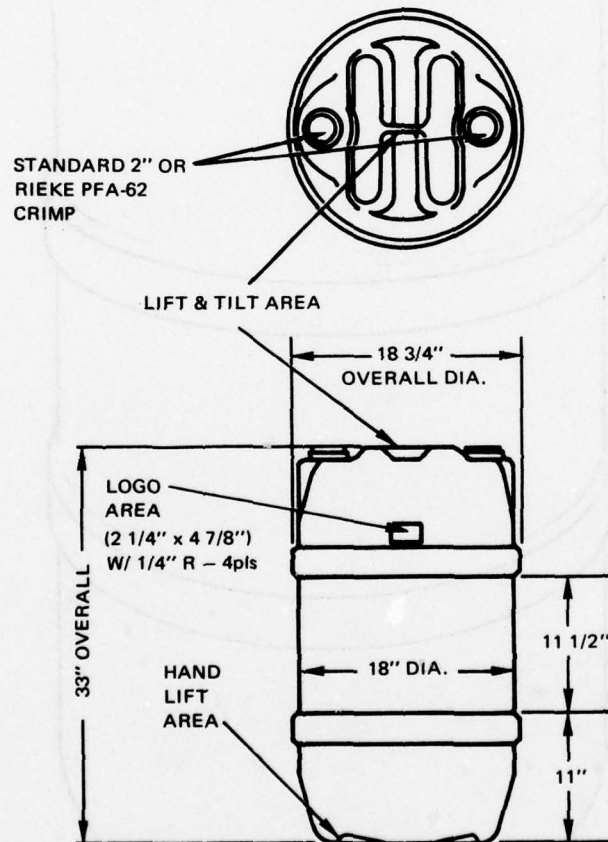

4. 55 Gallon, Blow Molded, Polyethylene Drums.

Supplier: Hedwin Corporation, 1600 Roland Heights Avenue,
Baltimore, MD

Construction: One piece, blow molded of high density
polyethylene. (See Figure 14).



5. 55 Gallon, Rotationally Molded Polyethylene Drum

Supplier: Container Corporation of America,
1205 E 12th Street, Wilmington, DE

Construction: One piece, 3 layer, rotationally
molded of high density polyethylene.

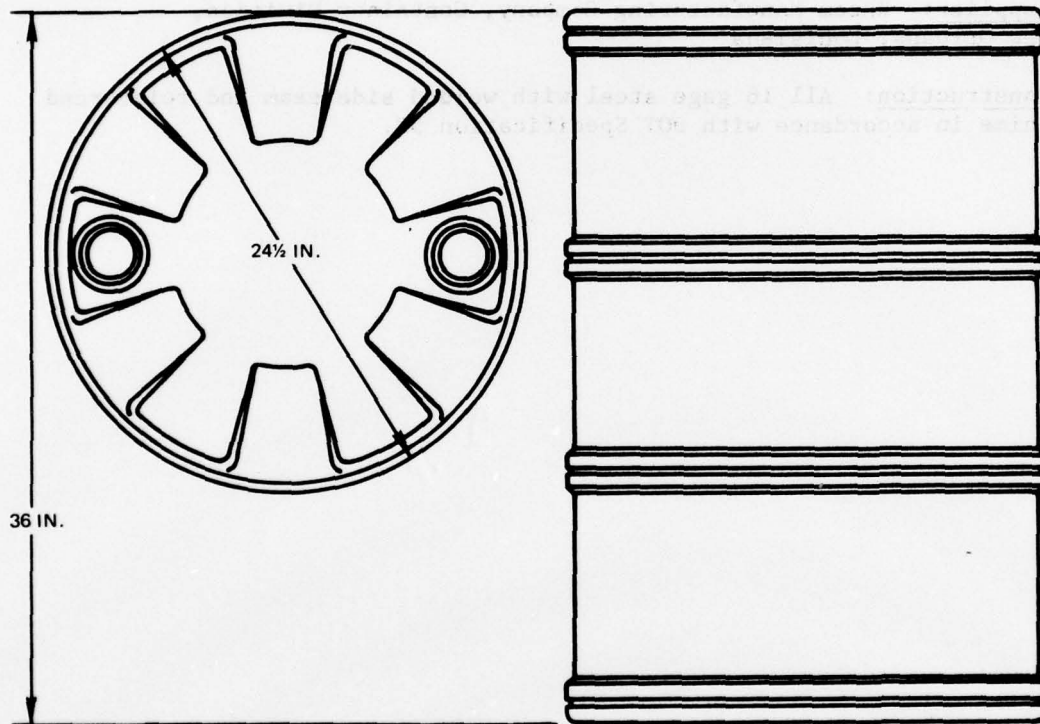

DIMENSIONS

"ALL DIMENSIONS ARE NOTED
APPROXIMATE IN INCHES."

6. 55 Gallon, Steel, DOT Specification 17E Drum.

Supplier: Florida Drum Company,
Pensacola, FL

Construction: All 18 gage steel with welded side seam and rolled device in accordance with DOT Specification 17E.

7. 55 Gallon, Steel, DOT Specification 5B Drum.

Supplier: Rheem Manufacturing Company, Container Division,
New Orleans, Louisiana

Construction: All 16 gage steel with welded side seam and reinforced chime in accordance with DOT Specification 5B.

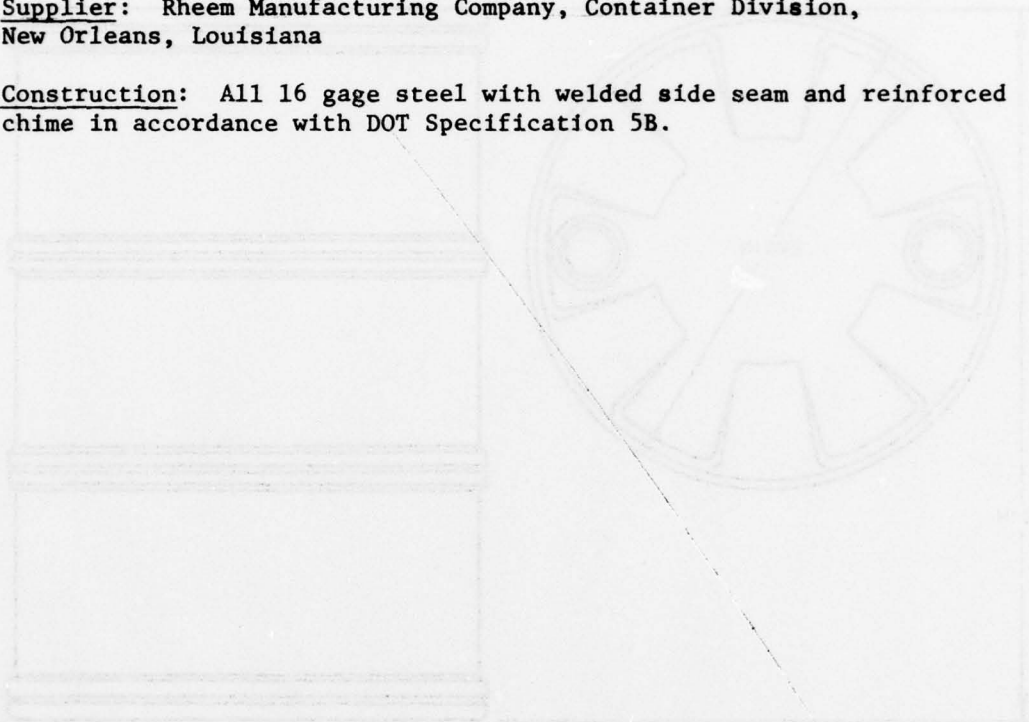

ALL DIMENSIONS ARE IN INCHES
UNLESS OTHERWISE SPECIFIED

APPENDIX C

Data for 25 square foot partial and full exposure fires (Tests 1 through 8, 11, and 12)

DRUM FIRE TESTS PHASE II

DATA FROM TEST NUMBER 1

DRUM SIZE: 5 GAL; MATERIAL: POLYETHYLENE

FIRE SIZE: 25 SQ. FT.; INVOLVEMENT: FULL

CARGO: JP-4

THERMOCOUPLE ARRANGEMENT:

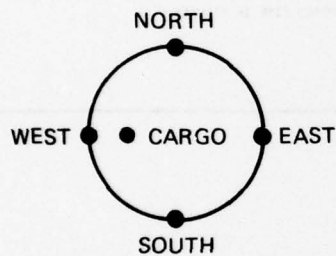

OTHER SENSORS:

Pressure transducer in drum

Radiometer located at North end of fire pan 18' from fire

	1a	1b	1c
TIME TO FAILURE (MIN:SEC):	0:45	0:34	0:23
METHOD OF FAILURE:	Burning	Burning	Burning
PRESSURE AT FAILURE (PSIG):	0	0	0

COMMENTS:

North thermocouple went open after 3 min.

DATA FROM TEST NUMBER 1

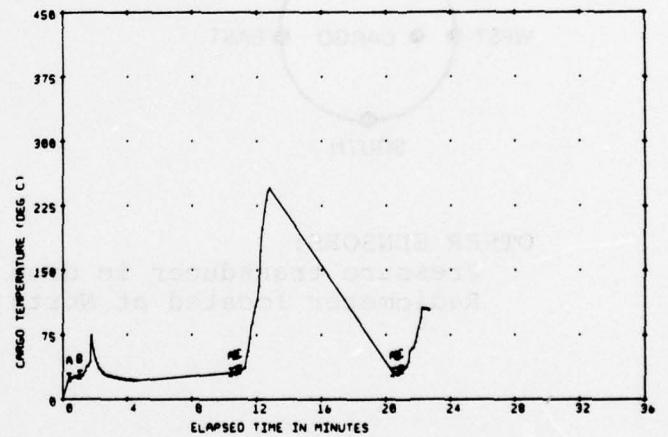
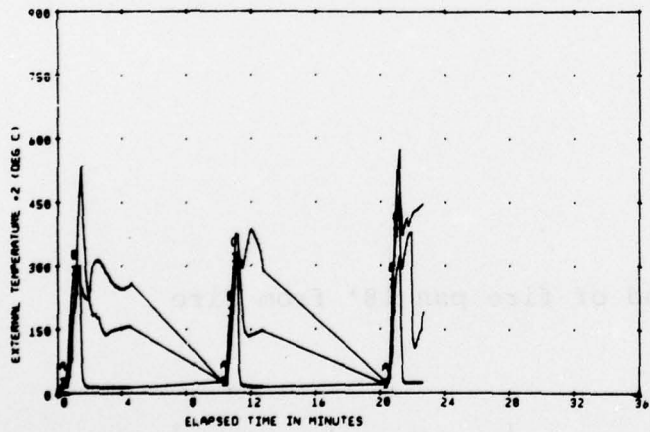
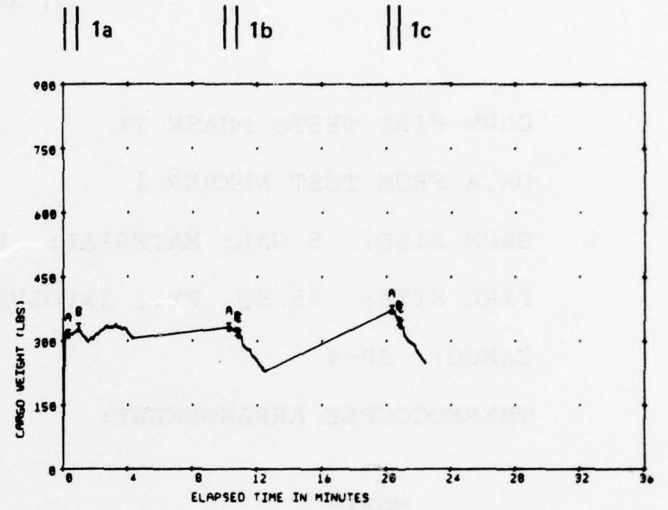
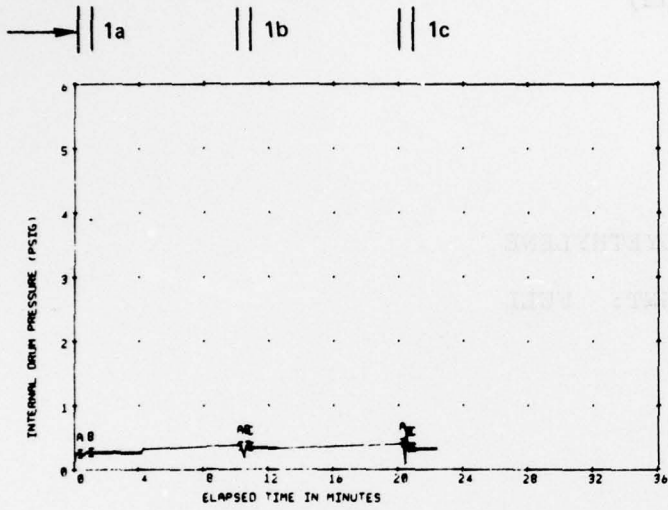

KEY:
 A = IGNITION
 B = FAILURE
 C = VISIBLE FAILURE

DRUM FIRE TESTS PHASE II

DATA FROM TEST NUMBER 2

DRUM SIZE: 5 GAL; MATERIAL: POLYETHYLENE

FIRE SIZE: 25 SQ. FT.; INVOLVEMENT: PARTIAL

CARGO: JP-4

THERMOCOUPLE ARRANGEMENT:

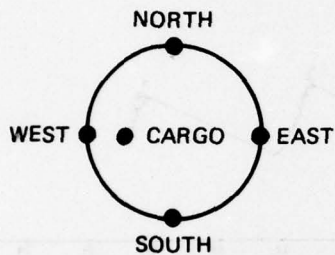

OTHER SENSORS:

Pressure transducer in drum

Radiometer located at North end of fire pan 18' from fire

	2a	2b	2c
TIME TO FAILURE (MIN:SEC):	0:37	0:21	0:21
METHOD OF FAILURE:	Burning	Burning	Burning
PRESSURE AT FAILURE (PSIG):	0.25	0	0

COMMENTS

DATA FROM TEST NUMBER 2

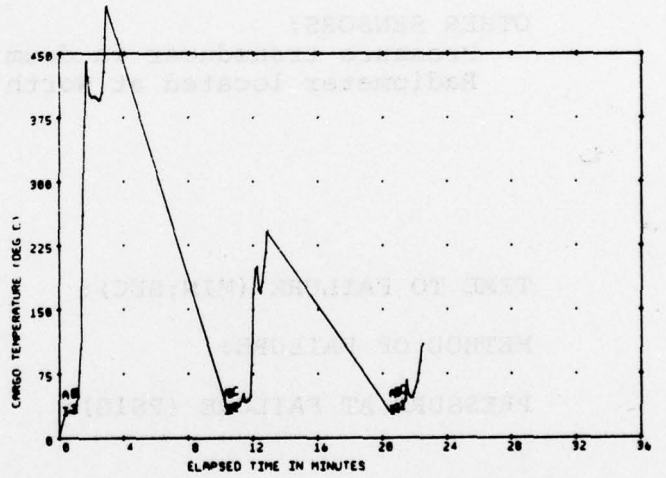
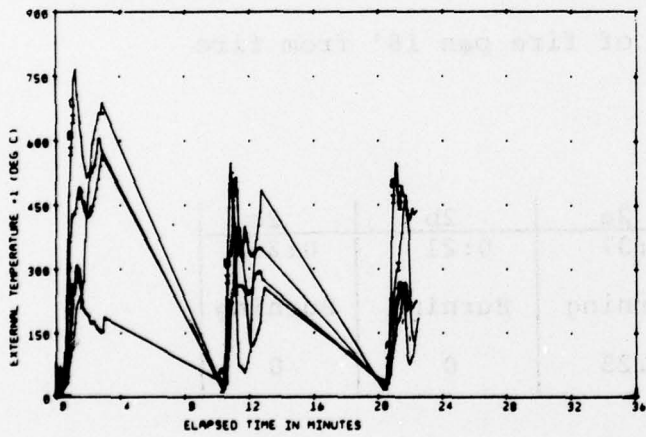
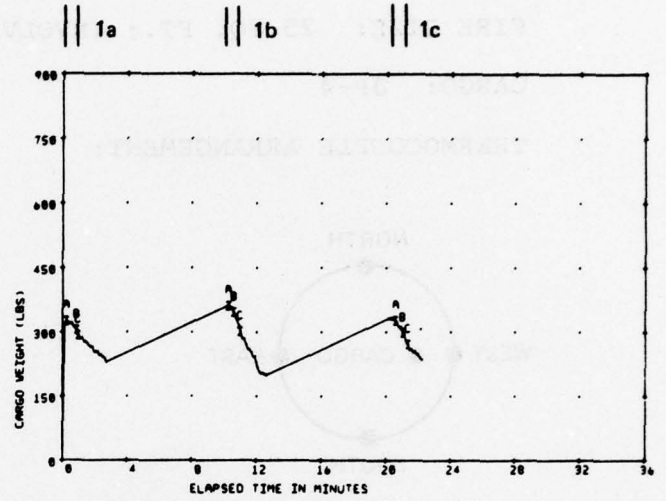
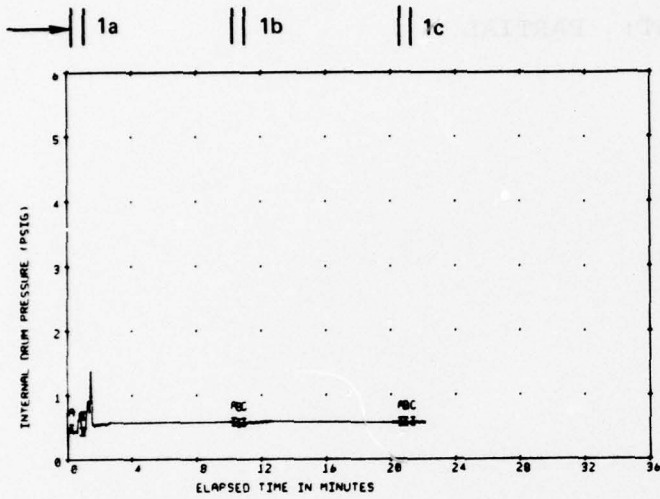

KEY:
 A = IGNITION
 B = FAILURE
 C = VISIBLE FAILURE

DRUM FIRE TESTS PHASE II

DATA FROM TEST NUMBER 3

DRUM SIZE: 15 GAL; MATERIAL: POLYETHYLENE

FIRE SIZE: 25 SQ. FT.; INVOLVEMENT: PARTIAL

CARGO: JP-4

THERMOCOUPLE ARRANGEMENT:

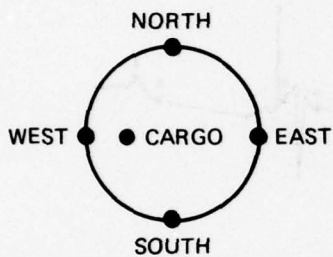

OTHER SENSORS:

Pressure transducer in drum

Radiometer located at North end of fire pan 18' from fire

TIME TO FAILURE (MIN:SEC):	3a 1:21	3b 1:58	3c 1:27
METHOD OF FAILURE:	Burning	Burning	Burning
PRESSURE AT FAILURE (PSIG):	0	0	0

COMMENTS:

3a) Visible failure - instruments did not record failure until 2'36". Drum failed with small leak and there was no radical weight loss.

3b) Drum slowly collapsed into the fire.

3c) Visible failure - weight loss very slow.

DATA FROM TEST NUMBER 3

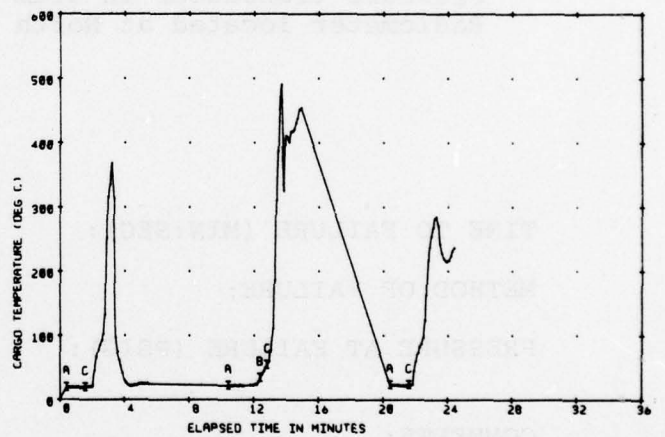
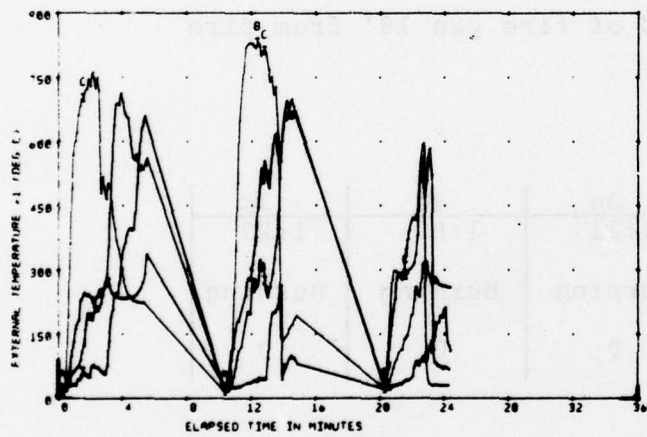
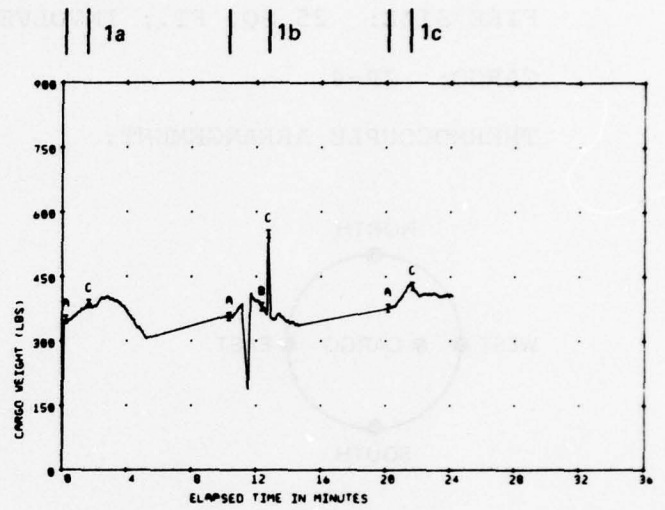
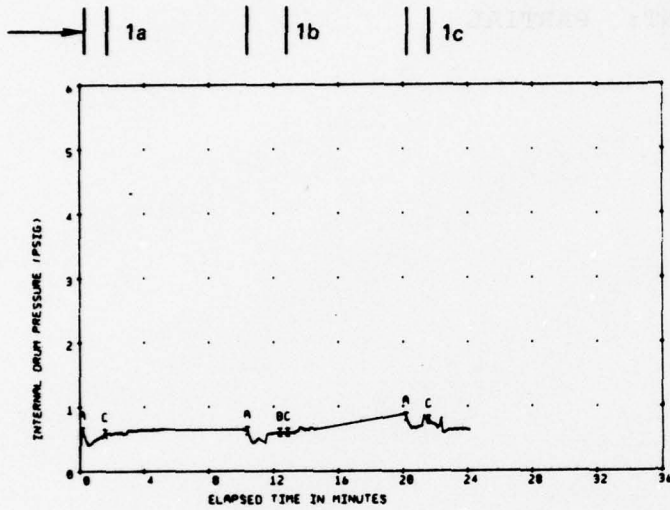

KEY:
 A = IGNITION
 B = FAILURE
 C = VISIBLE FAILURE

DRUM FIRE TESTS PHASE II

DATA FROM TEST NUMBER 4

DRUM SIZE: 15 GAL; MATERIAL: POLYETHYLENE

FIRE SIZE: 25 SQ. FT.; INVOLVEMENT: FULL

CARGO: JP-4

THERMOCOUPLE ARRANGEMENT:

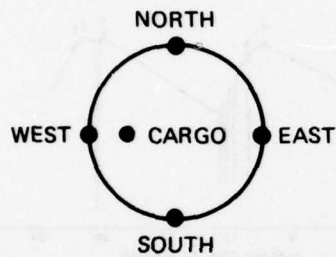

OTHER SENSORS:

Pressure transducer in drum

Radiometer located at North end of fire pan 18' from fire

	4a	4b	4c
TIME TO FAILURE (MIN:SEC):	1:25	1:12	1:41
METHOD OF FAILURE:	Burning	Burning	Burning
PRESSURE AT FAILURE (PSIG):	0	0	0

COMMENTS:

4b) Visible failure at 1:07.

4c) Visible failure at 1:17.

DATA FROM TEST NUMBER 4

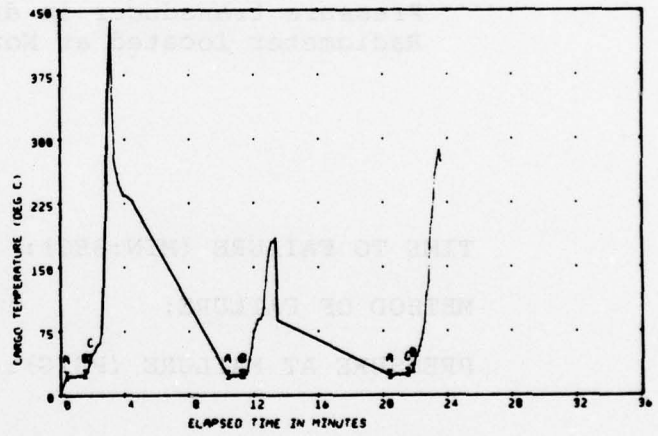
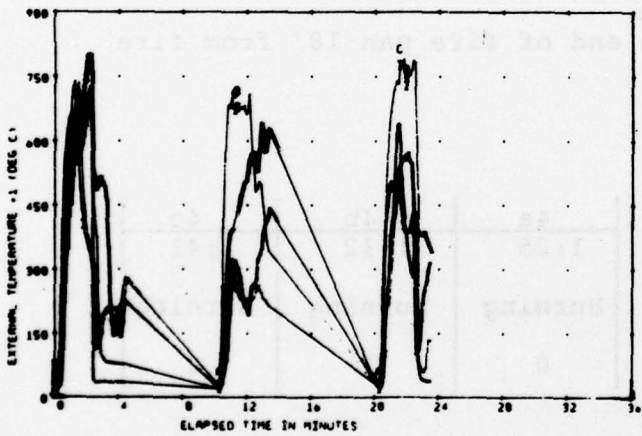
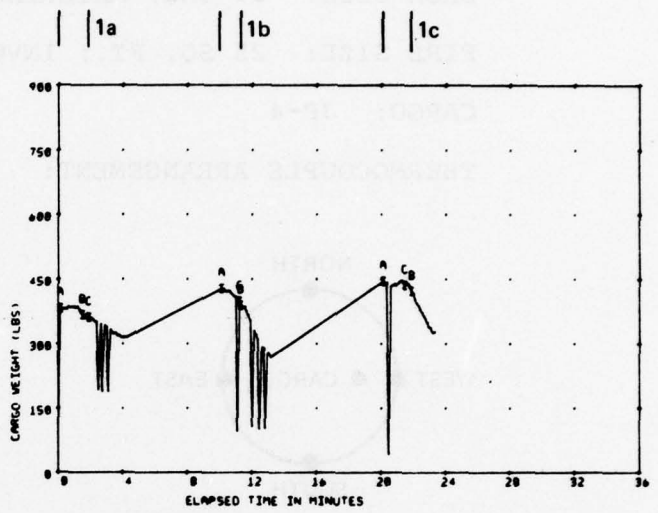
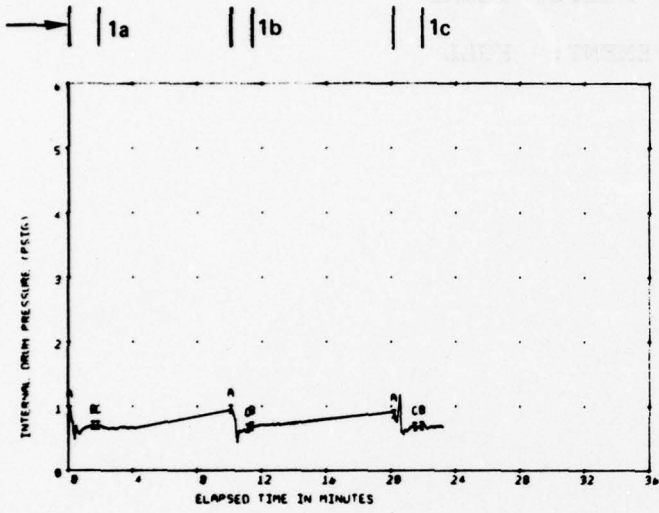

KEY:
 A = IGNITION
 B = FAILURE
 C = VISIBLE FAILURE

DRUM FIRE TESTS PHASE II

DATA FROM TEST NUMBER 5

DRUM SIZE: 30 GAL; MATERIAL: POLYETHYLENE

FIRE SIZE: 25 SQ. FT.; INVOLVEMENT: PARTIAL

CARGO: JP-4

THERMOCOUPLE ARRANGEMENT:

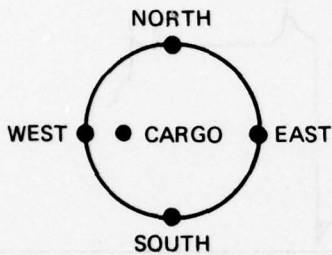

OTHER SENSORS:

Pressure transducer in drum

Radiometer located at North end of fire pan 18' from fire

	5a	5b	5c
TIME TO FAILURE (MIN:SEC):	1:56	2:01	1:31
METHOD OF FAILURE:	Burning	Burning	Burning
PRESSURE AT FAILURE (PSIG):	0	0	0

COMMENTS:

- 5a) Slight pressure drop shows that failure may have occurred 10 to 20 seconds earlier. Drum folded slowly into fire.
- 5c) Drum fell over due to bottom third softening.

DATA FROM TEST NUMBER 5

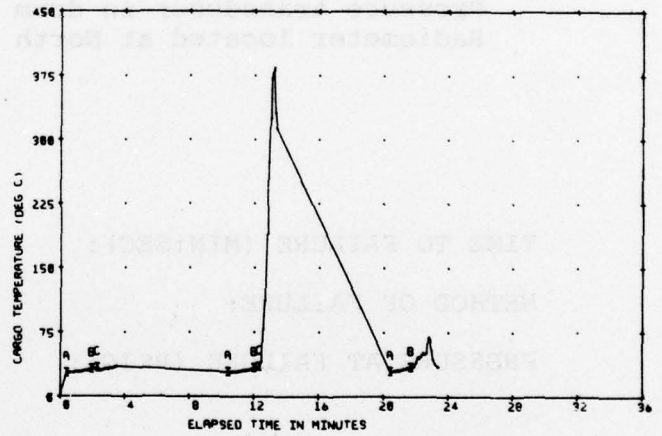
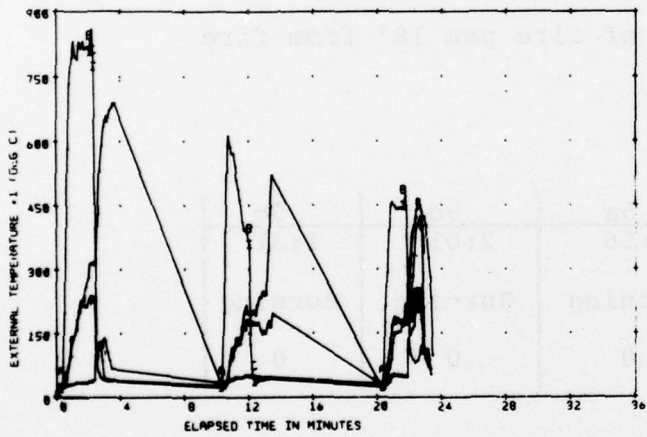
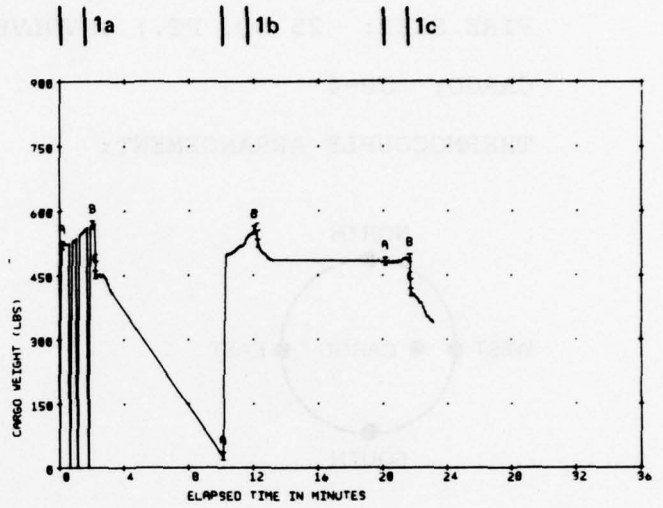
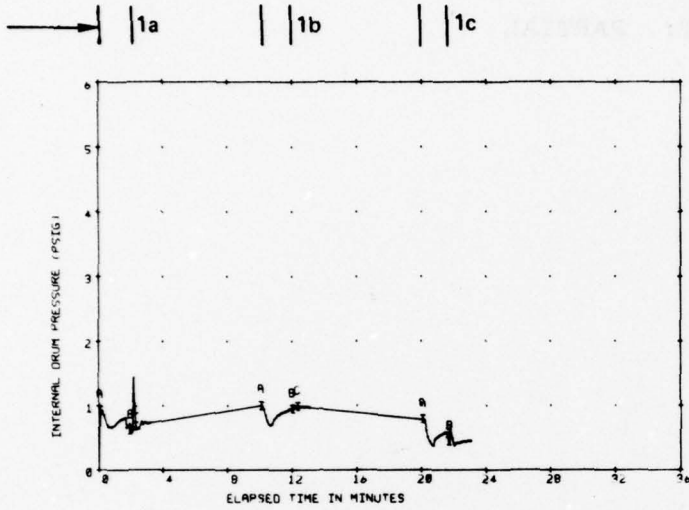

KEY:
 A = IGNITION
 B = FAILURE
 C = VISIBLE FAILURE

DRUM FIRE TESTS PHASE II

DATA FROM TEST NUMBER 6

DRUM SIZE: 30 GAL; MATERIAL: POLYETHYLENE

FIRE SIZE: 25 SQ.FT.; INVOLVEMENT: FULL

CARGO: JP-4

THERMOCOUPLE ARRANGEMENT:

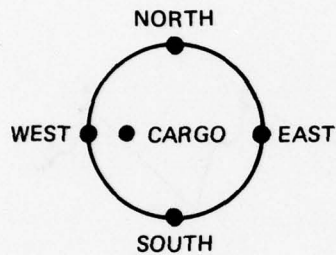

OTHER SENSORS:

Pressure transducer in drum

Radiometer located at North end of fire pan 18' from fire

	6a	6b	6c
TIME TO FAILURE (MIN:SEC):	2:07	0:19	0:26
METHOD OF FAILURE:	Burning	Burning	Burning
PRESSURE AT FAILURE (PSIG):	0	0	0

COMMENTS:

6a) Visible failure. Appeared to be a weight loss at 40 seconds. Drum failed on East side. Fire eddys noted under rolling drums.

6b) Drum failed on West side on bottom third.

DATA FROM TEST NUMBER 6

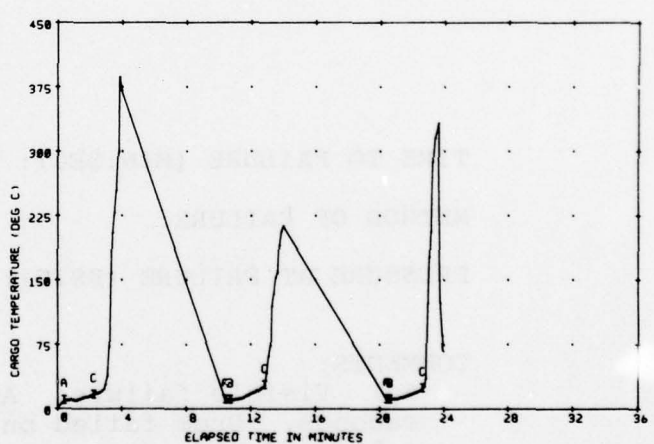
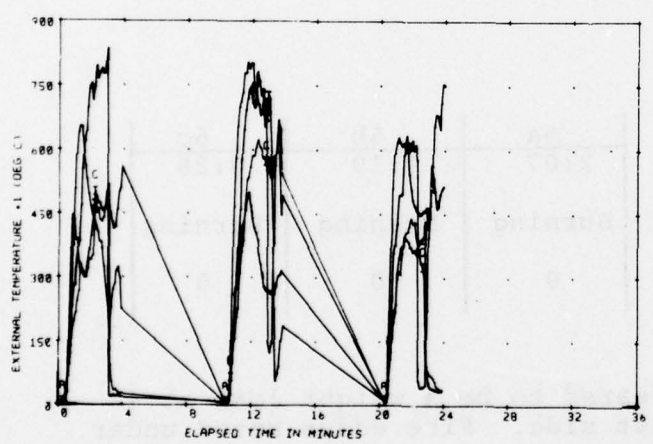
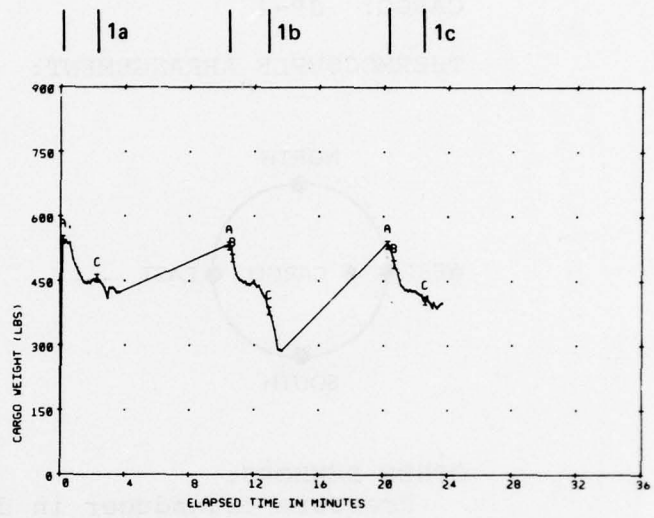
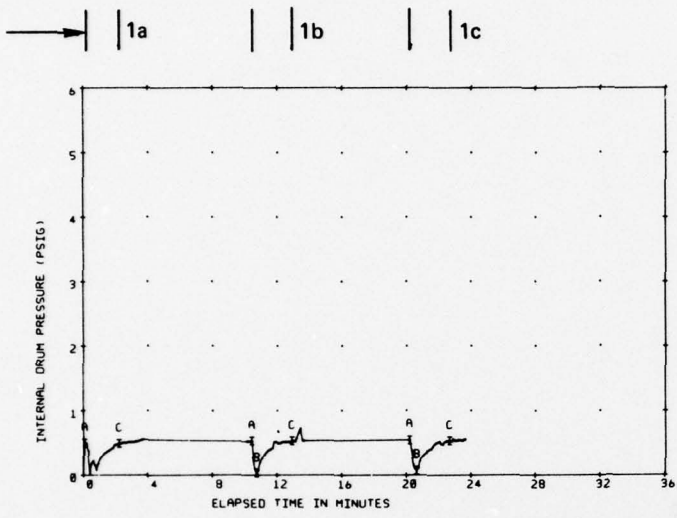

KEY:
 A = IGNITION
 B = FAILURE
 C = VISIBLE FAILURE

DRUM FIRE TESTS PHASE II

DATA FROM TEST NUMBER 7

DRUM SIZE: 55 GAL; MATERIAL: POLYETHYLENE

FIRE SIZE: 25 SQ. FT.; INVOLVEMENT: PARTIAL

CARGO: JP-4

THERMOCOUPLE ARRANGEMENT:

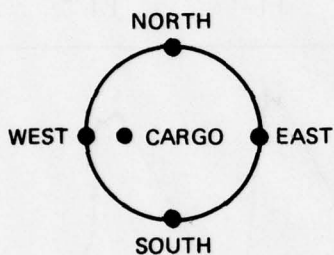

OTHER SENSORS:

Pressure transducer in drum

Radiometer located at North end of fire pan 18' from fire

TIME TO FAILURE (MIN:SEC):	7a 0:52	7b 0:58	7c 1:27
METHOD OF FAILURE:	Burning	Burning	Burning
PRESSURE AT FAILURE (PSIG):	0	0	0

COMMENTS:

- 7a) Drum leaked at SW corner at failure.
- 7b) Drum failure caused by bottom melting.
- 7c) Visible failure noted at 1:21.

DATA FROM TEST NUMBER 7

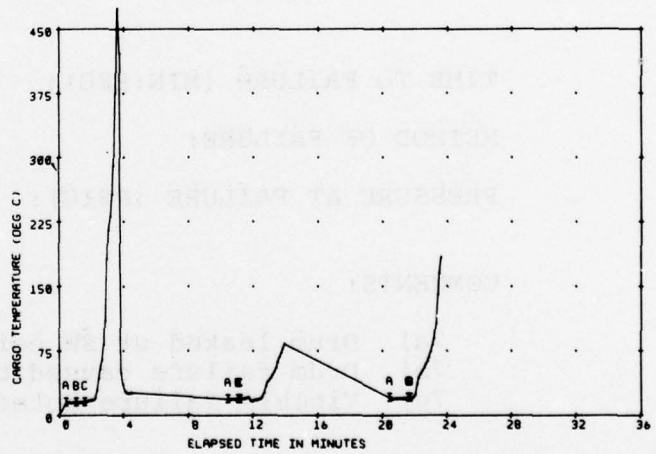
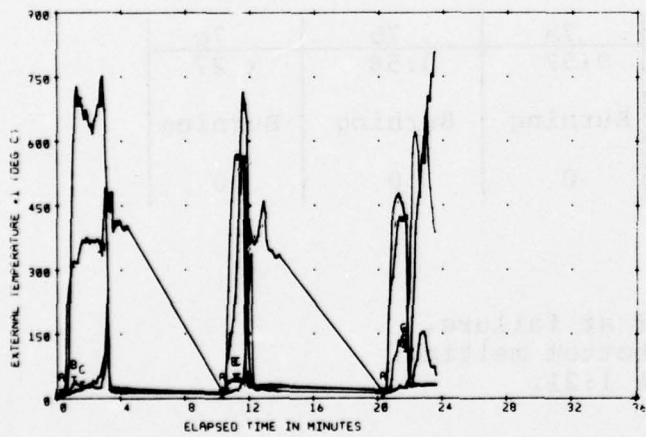
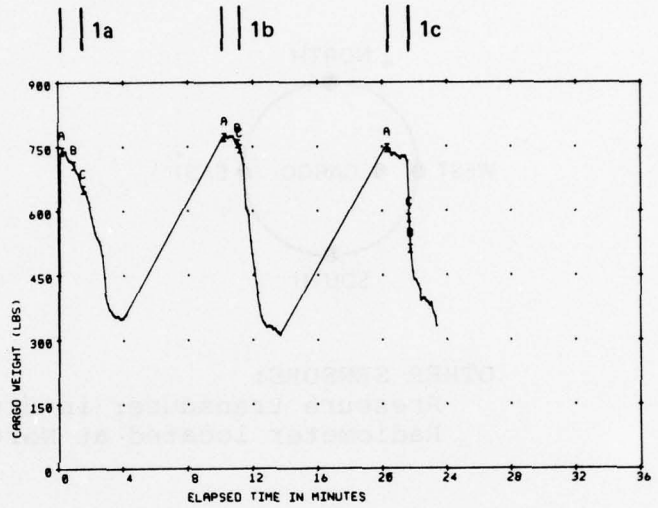
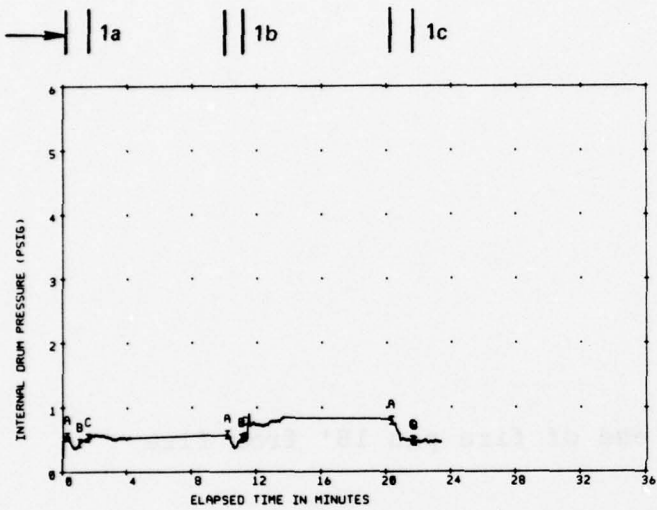

KEY:
 A = IGNITION
 B = FAILURE
 C = VISIBLE FAILURE

DRUM FIRE TESTS PHASE II

DATA FROM TEST NUMBER 8

DRUM SIZE: 55 GAL; MATERIAL: POLYETHYLENE

FIRE SIZE 25 SQ. FT.: INVOLVEMENT: FULL

CARGO: JP-4

THERMOCOUPLE ARRANGEMENT:

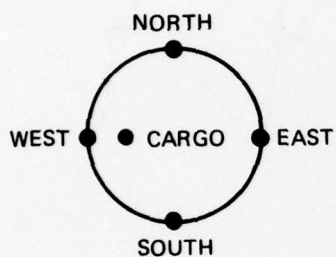

OTHER SENSORS:

Pressure transducer in drum

Radiometer located at North end of fire pan 18' from fire

	8a	8b	8c
TIME TO FAILURE (MIN:SEC):	1:19	1:28	1:29
METHOD OF FAILURE:	Burning	Burning	Burning
PRESSURE AT FAILURE (PSIG):	0	0	0

COMMENTS:

8a) Drum failed at middle on SW side.

8b) Visible failure at 1:15.

DATA FROM TEST NUMBER 8

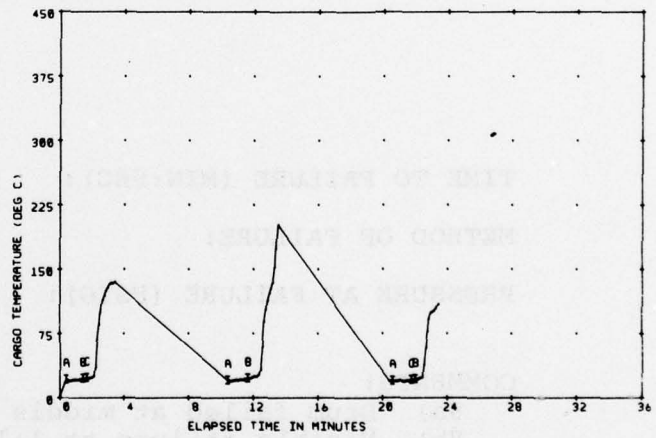
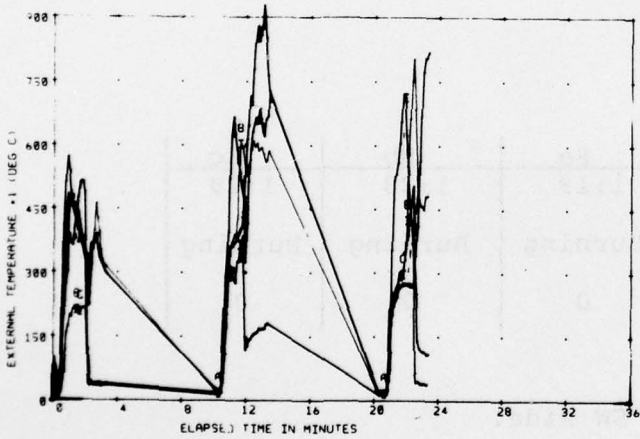
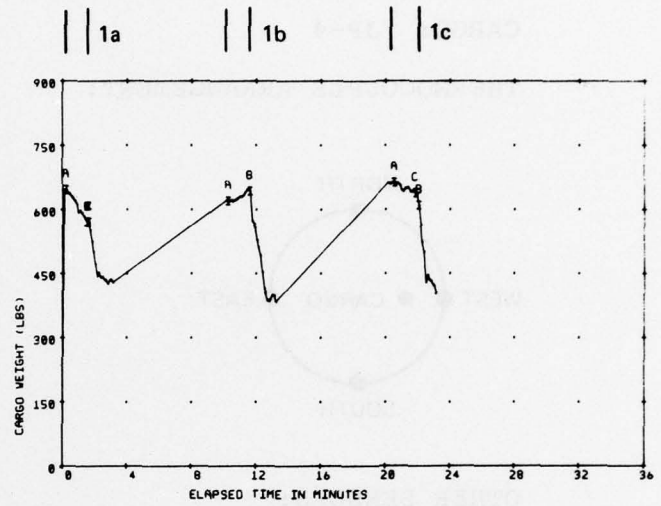
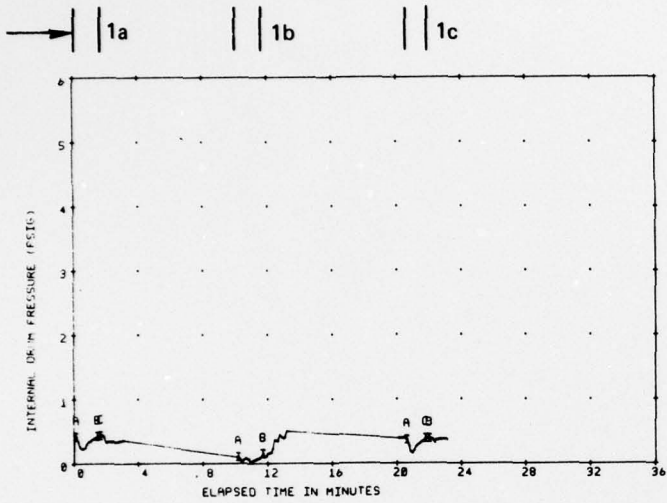

KEY:
 A = IGNITION
 B = FAILURE
 C = VISIBLE FAILURE

DRUM FIRE TESTS PHASE II

DATA FROM TEST NUMBER 11

DRUM SIZE: 55 GAL; MATERIAL: STEEL (17E)

FIRE SIZE: 25 SQ. FT.; INVOLVEMENT: PARTIAL

11c THERMOCOUPLE ARRANGEMENT AND DRUM ORIENTATION

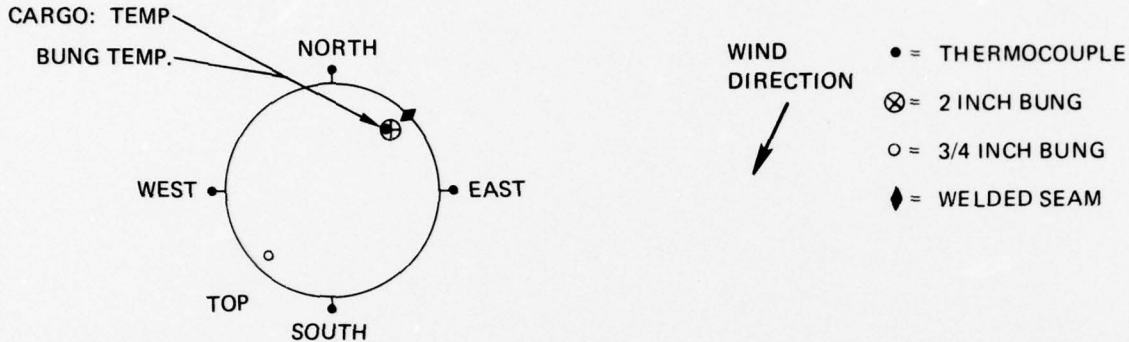

OTHER SENSORS:

Pressure transducer in 3/4 inch bung

Radiometer located at Northend of fire pan 18' from fire edge

METHOD OF FAILURE:	JETTING	EXPLOSION
TIME TO FAILURE (MIN:SEC):	-	14.23
PRESSURE AT FAILURE (PSIG):	-	59.9

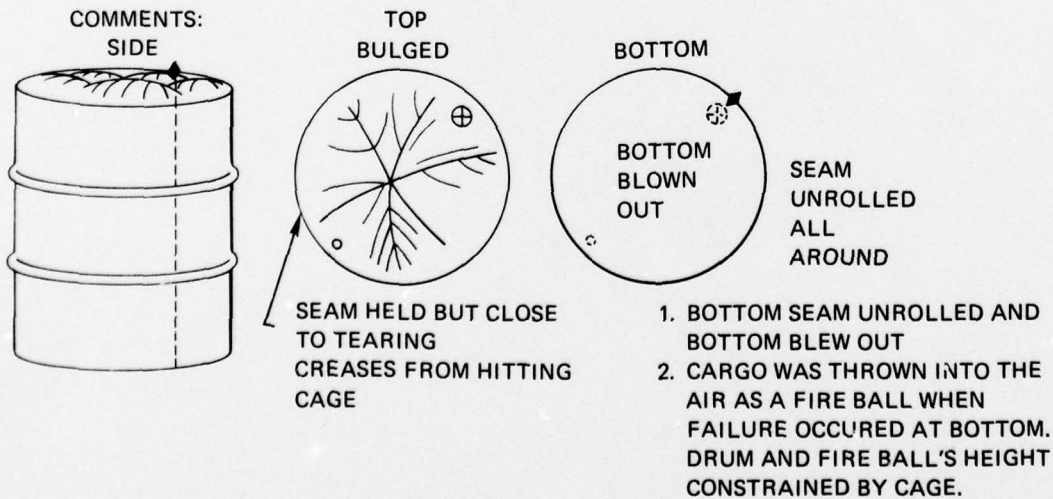

11b THERMOCOUPLE ARRANGEMENT AND DRUM ORIENTATION

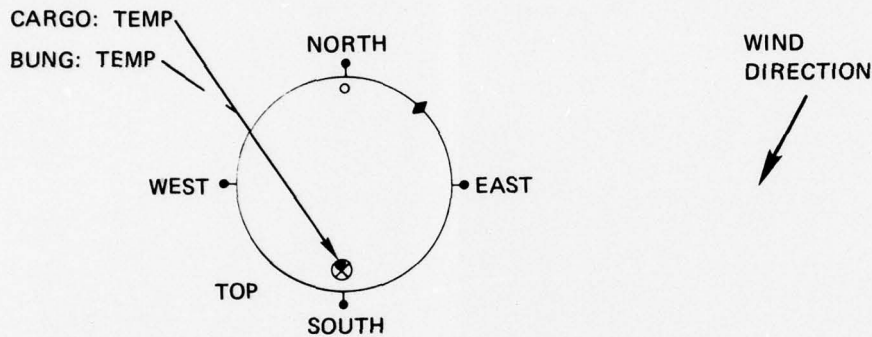

OTHER SENSORS:

Pressure transducer in 3/4 inch bung

Radiometer located at North end of fire pan 18' from fire edge

METHOD OF FAILURE:

JETTING

EXPLOSION

TIME TO FAILURE (MIN:SEC):

7:21

-

PRESSURE AT FAILURE (PSIG):

16.2

-

COMMENTS:

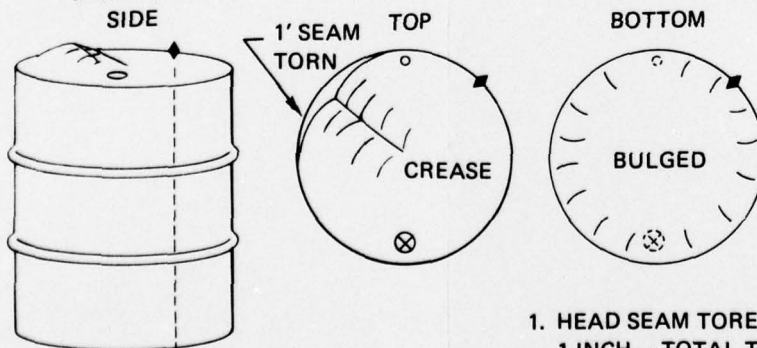

1. HEAD SEAM TORE AND BULGED UP APPROXIMATELY 1 INCH - TOTAL TEAR 1' - OCCURRED AT 16.2 PSIG
2. DRUM JETTED UNTIL FIRE WENT OUT

11a THERMOCOUPLE ARRANGEMENT AND DRUM ORIENTATION

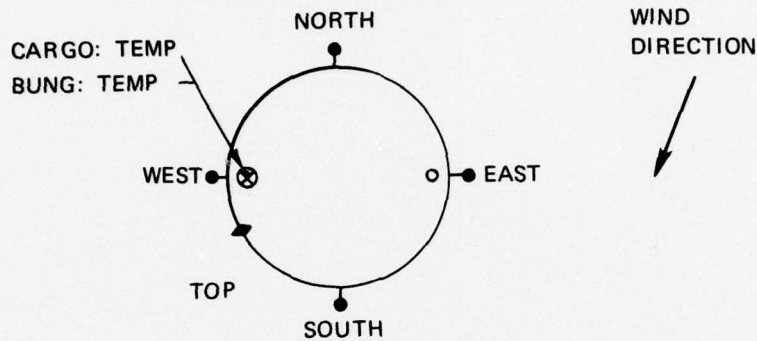

OTHER SENSORS:

Pressure transducer in 3/4 inch bung

Radiometer located at North end of fire pan 18' from fire edge

METHOD OF FAILURE:	JETTING	EXPLOSION
TIME TO FAILURE (MIN:SEC):	1:04	15:06
PRESSURE AT FAILURE (PSIG):	11.3	50.2

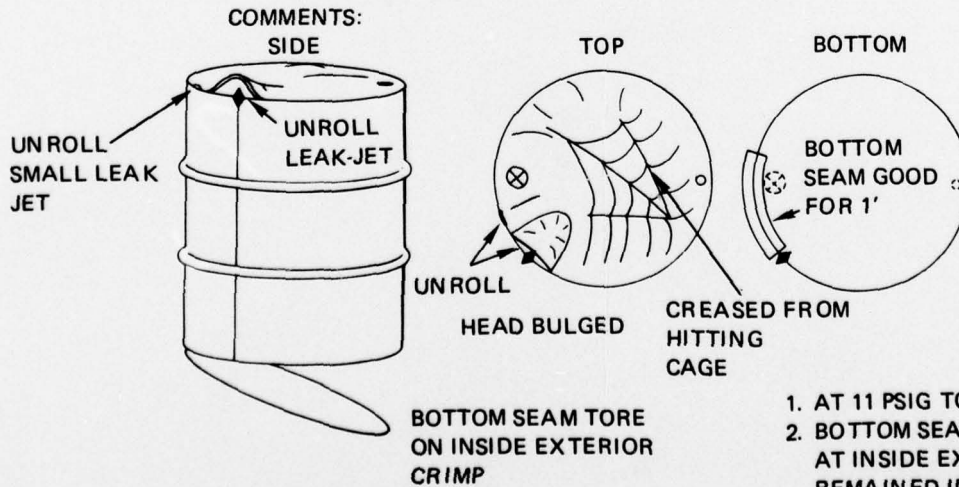

1. AT 11 PSIG TOP SPLIT IN TWO PLACES
2. BOTTOM SEAM FAILED BY TEARING AT INSIDE EXTERIOR SEAM—ONLY 1 FOOT REMAINED IN TACT
3. CARGO WAS THROWN INTO THE AIR AS A FIRE BALL WHEN FAILURE OCCURRED AT BOTTOM. DRUM AND FIRE BALL'S HEIGHT CONSTRAINED BY CAGE

5

DATA FROM TEST #11

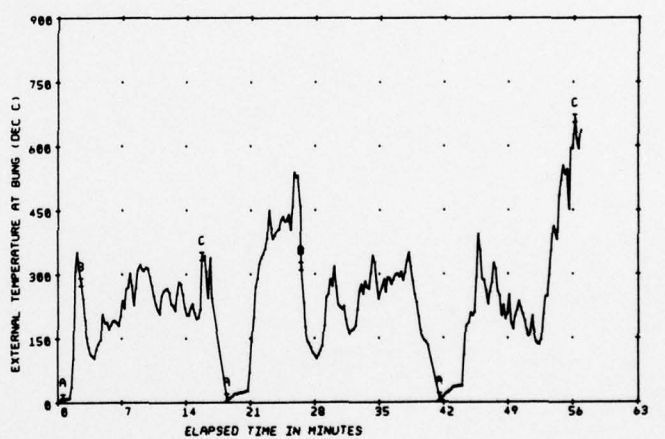
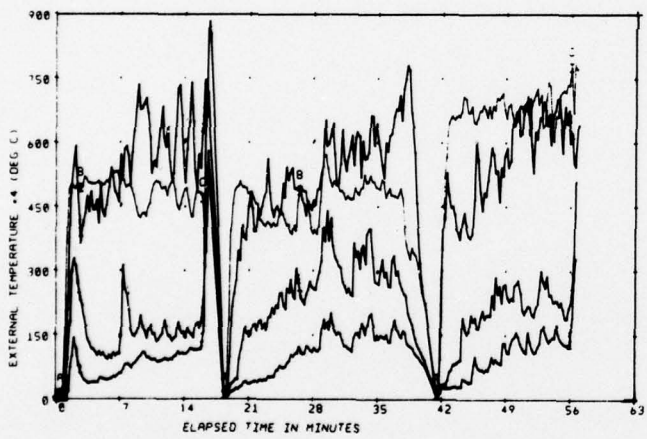
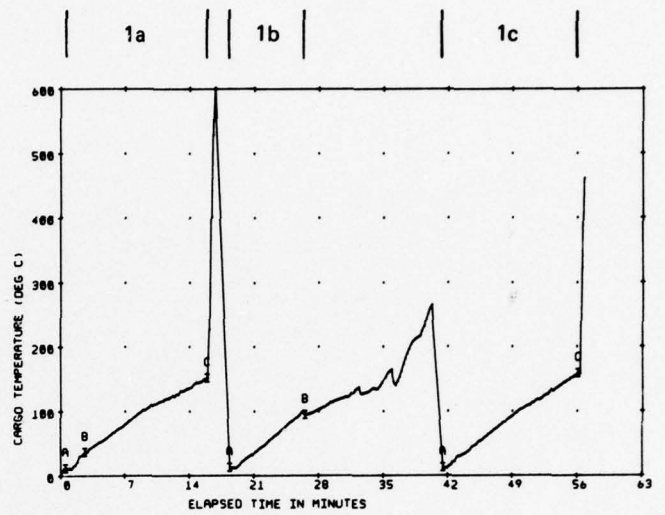
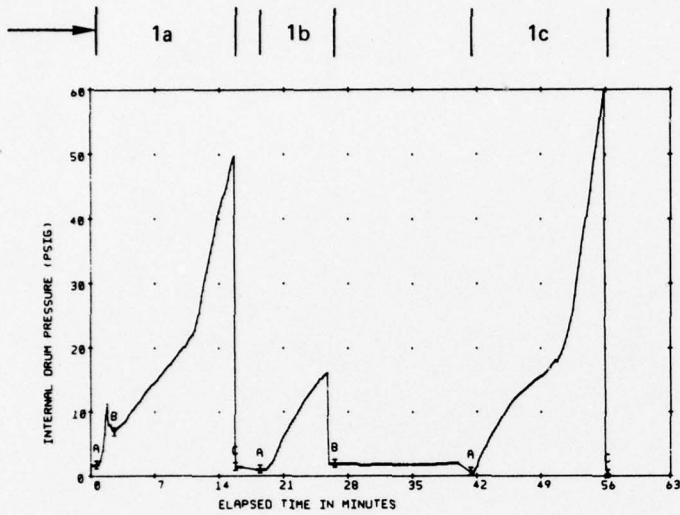

KEY:
 A = IGNITION
 B = FAILURE
 C = VISIBLE FAILURE

PRECEDING PAGE BLANK-NOT FILMED

DRUM FIRE TESTS PHASE II

DATA FROM TEST NUMBER 12

DRUM SIZE 55 GAL; MATERIAL: STEEL (17E)

FIRE SIZE: 25 SQ. FT.; INVOLVEMENT: FULL

CARGO: JP-4

12a THERMOCOUPLE ARRANGEMENT AND DRUM ORIENTATION

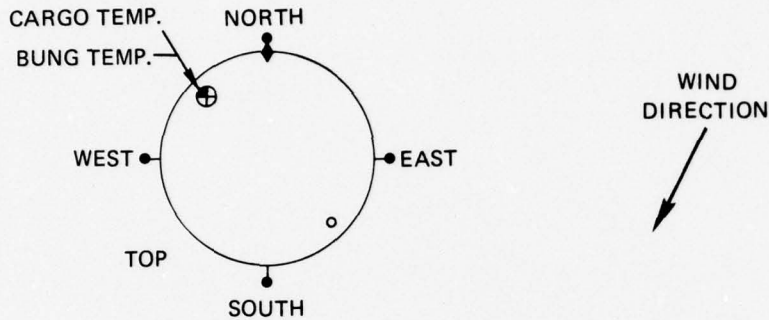

OTHER SENSORS:

Pressure transducer in 3/4 inch bung

Radiometer located at North end of fire pan 18' from fire edge.

METHOD OF FAILURE:	JETTING	EXPLOSION
TIME TO FAILURE (MIN:SEC):	5.53	-
PRESSURE AT FAILURE (PSIG):	16.8	-

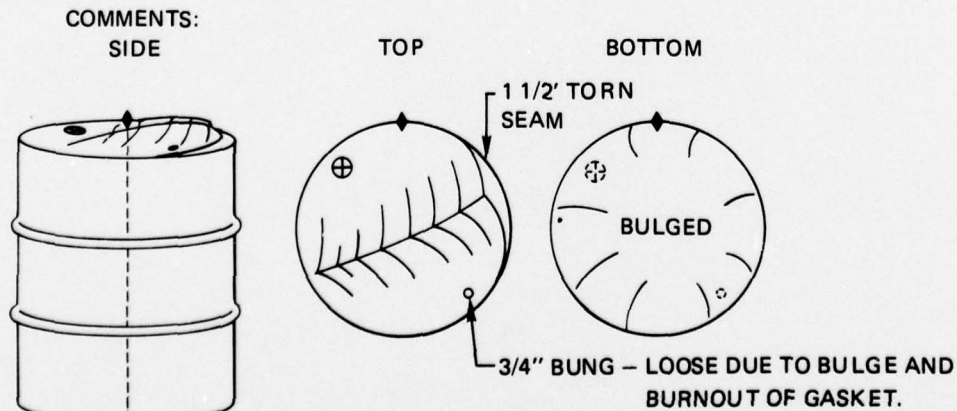

1. DRUM FAILED BY JETTING - SEAM AT TOP WAS TORN AT INSIDE EXTERIOR FOR 1 1/2 FOOT

PRECEDING PAGE BLANK-NOT FILMED

12b THERMOCOUPLE ARRANGEMENT AND DRUM ORIENTATION

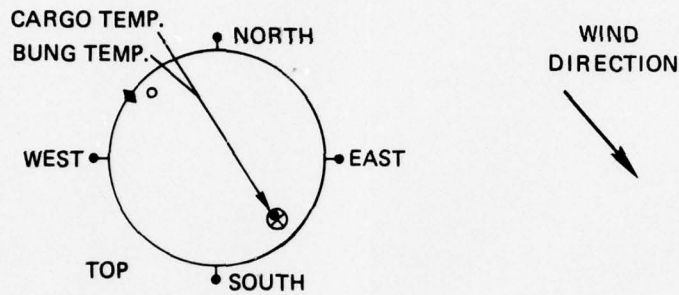

OTHER SENSORS:

Pressure transducer in 3/4 inch bung

Radiometer located at North end of fire pan 18' from fire edge

METHOD OF FAILURE:	JETTING	EXPLOSION
TIME TO FAILURE (MIN:SEC):	5:24	-
PRESSURE AT FAILURE (PSIG):	18.3	-

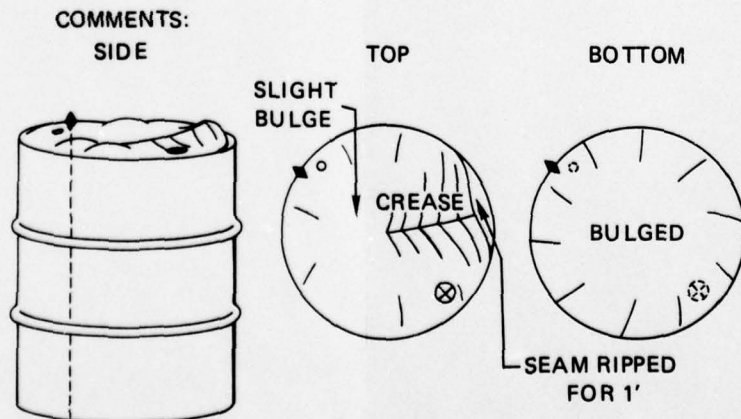

1. DRUM FAILED BY JETTING - SEAM AT TOP WAS TORN AT INSIDE EXTERIOR FOR 1 FOOT

J

12c THERMOCOUPLE ARRANGEMENT AND DRUM ORIENTATION

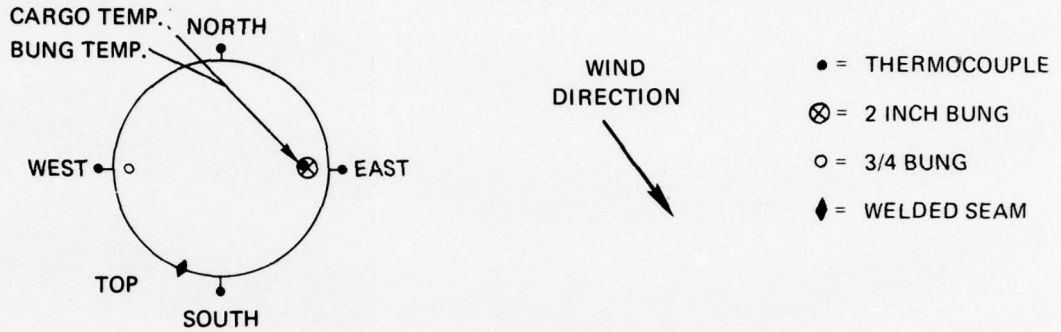

OTHER SENSORS:

Pressure transducer in 3/4 inch bung

Radiometer located at North end of fire pan 18' from fire edge

METHOD OF FAILURE:	JETTING	EXPLOSION
TIME TO FAILURE (MIN:SEC):	6:29	10:58
PRESSURE AT FAILURE (PSIG):	14.9	59.1

COMMENTS:

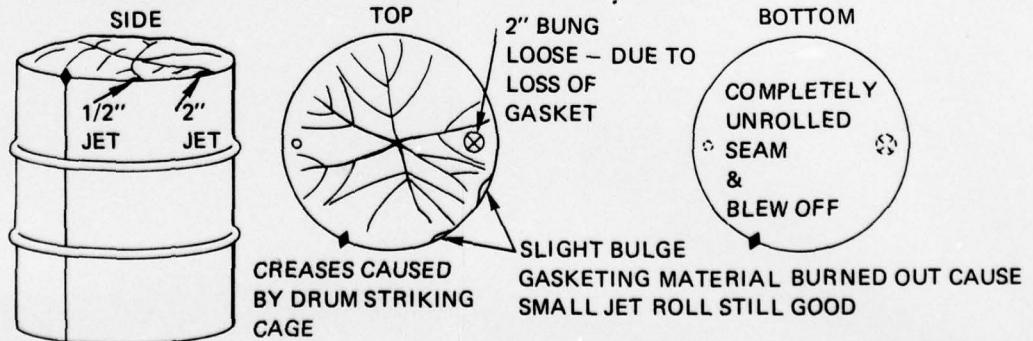

1. VERY SMALL JETS FOLLOWED BY BOTTOM FAILURE WHICH WAS CAUSED BY SEAM UNROLLING. BOTTOM COMPLETELY REMOVED.
2. EXPLOSION VIOLENT - CAGE DAMAGED - SW LEG WELD BROKEN OFF. CARCO WAS THROWN INTO THE AIR AS A FIRE BALL. DRUM AND FIRE BALL HEIGHT RESTRICTED BY CAGE.

3

DATA FROM TEST #12

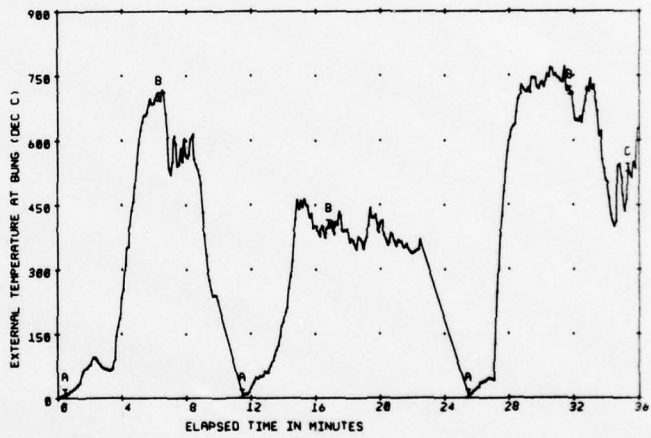
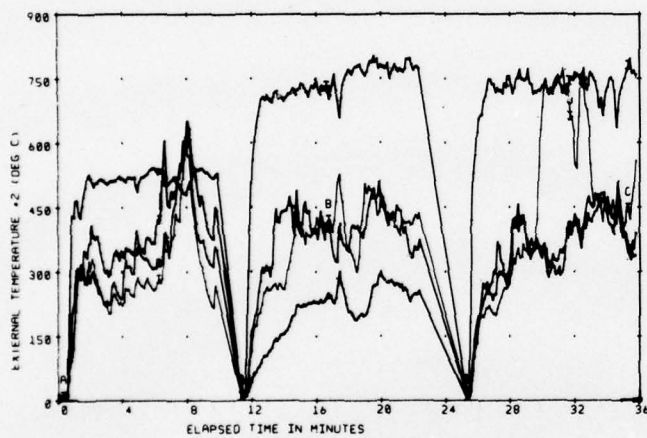
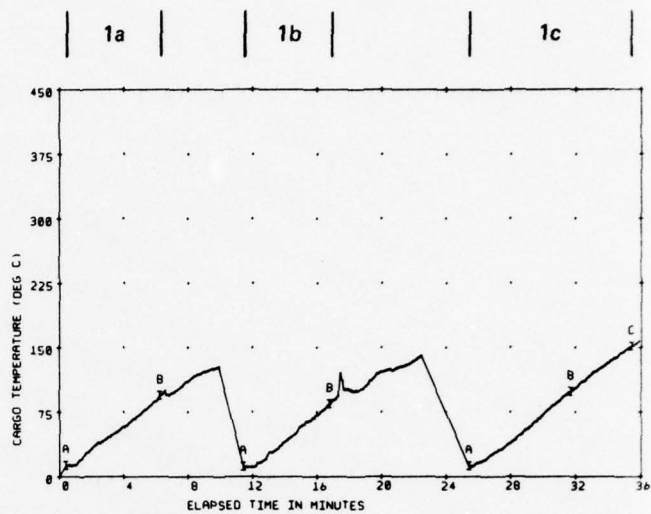
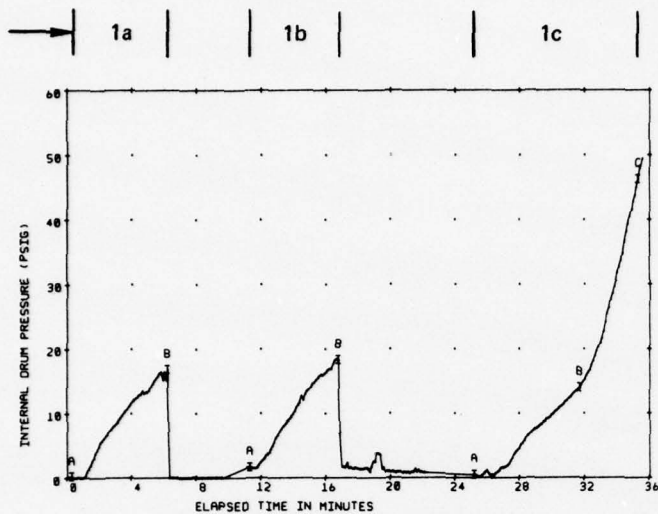

KEY:
 A = IGNITION
 B = FAILURE
 C = VISIBLE FAILURE

APPENDIX D

Data for 90 square foot full exposure fires with 55 gallon drums (Tests 9, 10, and 13 through 18).

DRUM FIRE TESTS PHASE II

DATA FROM TEST NUMBER 9

DRUM SIZE: 55 GAL; MATERIAL: POLYETHYLENE

FIRE SIZE: 90 SQ. FT.; INVOLVEMENT: FULL

CARGO: WATER

THERMOCOUPLE ARRANGEMENT:

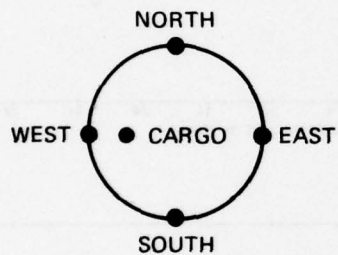

OTHER SENSORS:

Pressure transducer in drum

Radiometer located at North end of fire pan 18' from fire

	9a	9b	9c
TIME TO FAILURE (MIN:SEC):	1:32	2:26	1:31
METHOD OF FAILURE:	Burning	Burning	Burning
PRESSURE AT FAILURE (PSIG):	0	0	0

COMMENTS:

DATA FROM TEST NUMBER 9

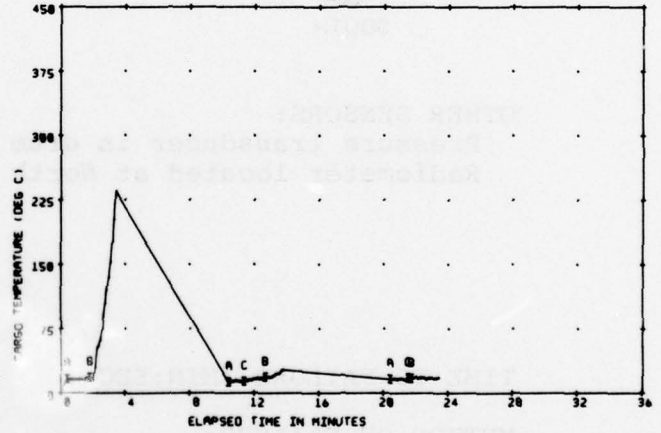
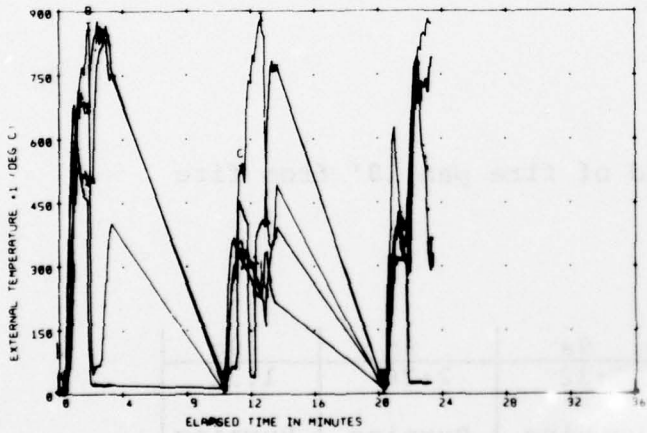
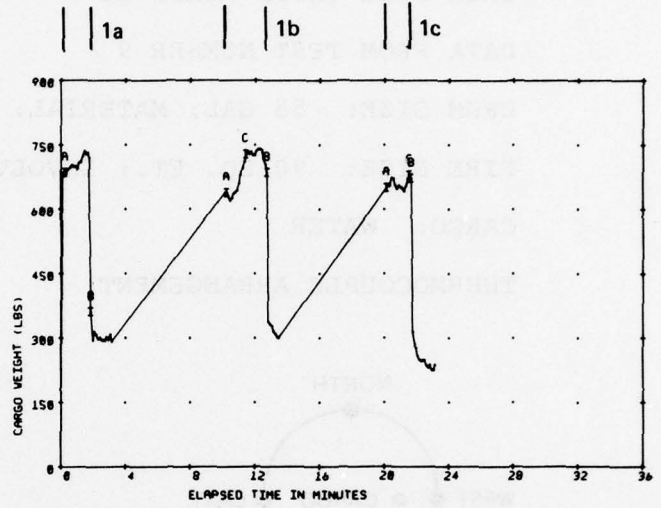
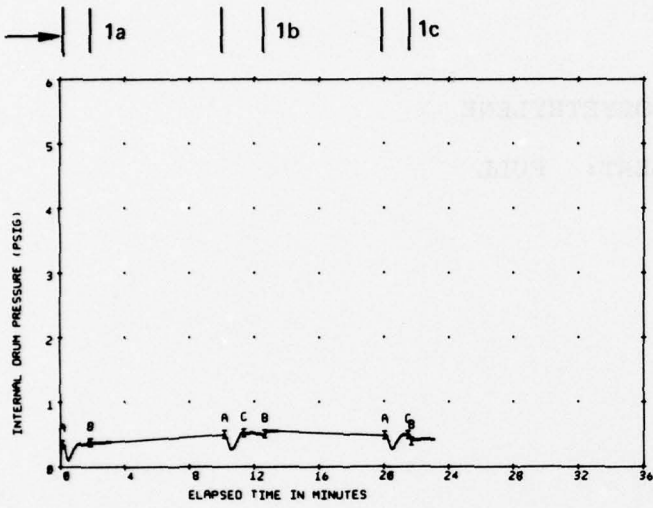

KEY:
 A = IGNITION
 B = FAILURE
 C = VISIBLE FAILURE

DRUM FIRE TESTS PHASE II

DATA FROM TEST NUMBER 10

DRUM SIZE: 55 GAL; MATERIAL: POLYETHYLENE

FIRE SIZE: 90 SQ. FT.; INVOLVEMENT: FULL

CARGO: LUBRICATING OIL

THERMOCOUPLE ARRANGEMENT:

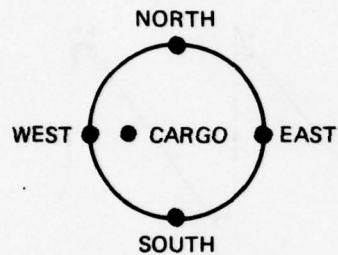

OTHER SENSORS:

Pressure transducer in drum

Radiometer located at North end of fire pan 18' from fire

TIME TO FAILURE (MIN:SEC):	10a 0:47	10b 1:00	10c 0:51
METHOD OF FAILURE:	Burning	Burning	Burning
PRESSURE AT FAILURE (PSIG):	0	0	0

COMMENTS:

10a) Drum fell to Southeast after a period of 1:15 into the fire.

10c) Drum collapsed into fire after 0:52 exposure.

DATA FROM TEST NUMBER 10

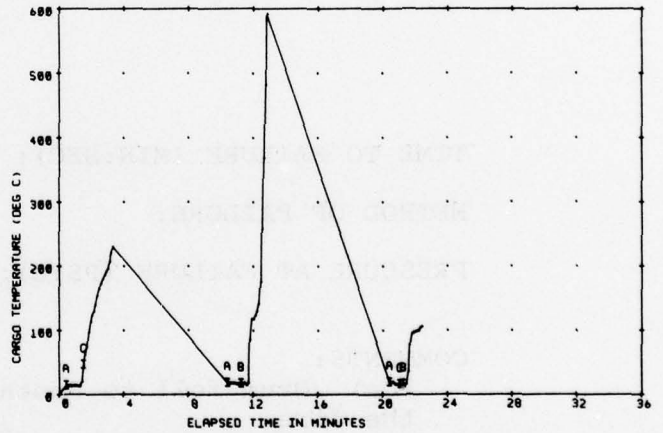
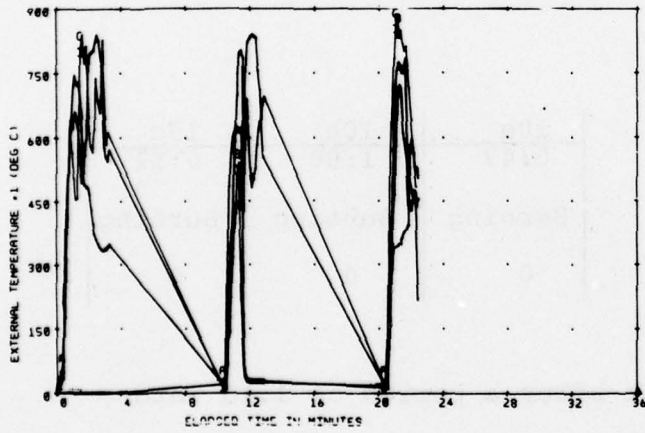
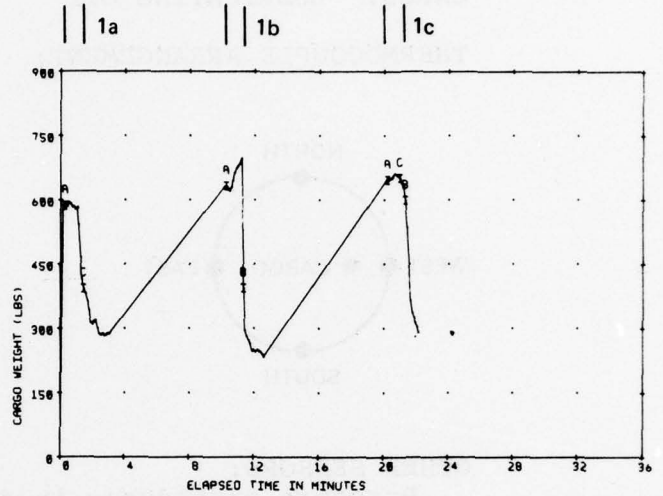
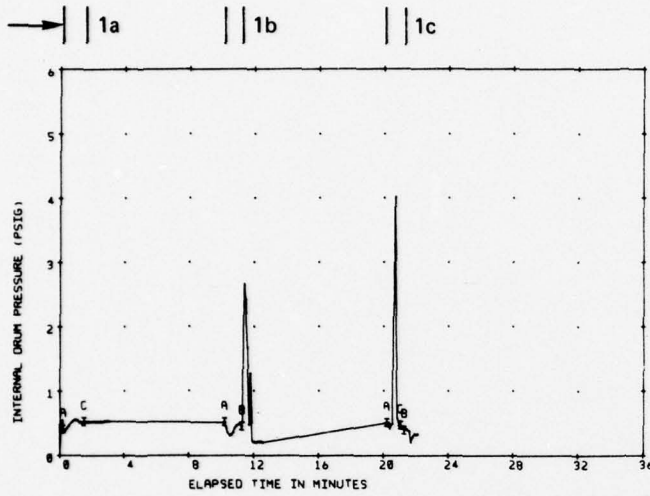

KEY:
 A = IGNITION
 B = FAILURE
 C = VISIBLE FAILURE

DRUM FIRE TESTS PHASE II

DATA FROM TEST NUMBER 13

DRUM SIZE: 55 GAL; MATERIAL: STEEL (17E)

FIRE SIZE: 90 SQ. FT.; INVOLVEMENT: FULL

CARGO: WATER

13a THERMOCOUPLE ARRANGEMENT AND DRUM ORIENTATION

13b

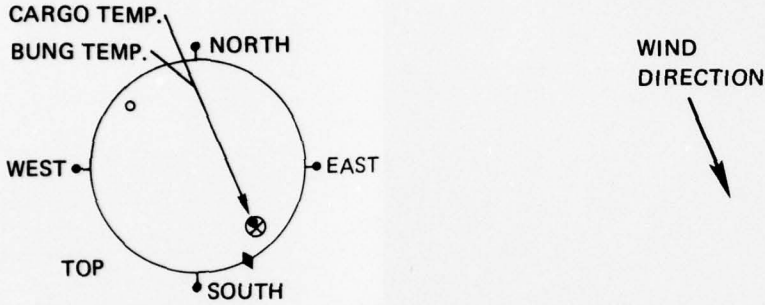

OTHER SENSORS:

Pressure transducer in 3/4 inch bung

Radiometer located at North end of fire pan 18' from fire edge

OTHE
Pr
Ra

METHOD OF FAILURE:

FIRE BURNED OUT

METH

TIME TO FAILURE (MIN:SEC):

4:0

TIME

PRESSURE AT FAILURE (PSIG):

2.3

PRES

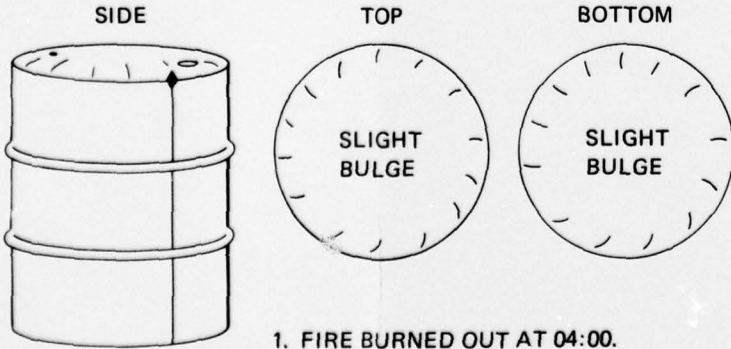

1. FIRE BURNED OUT AT 04:00.

13b THERMOCOUPLE ARRANGEMENT AND DRUM ORIENTATION

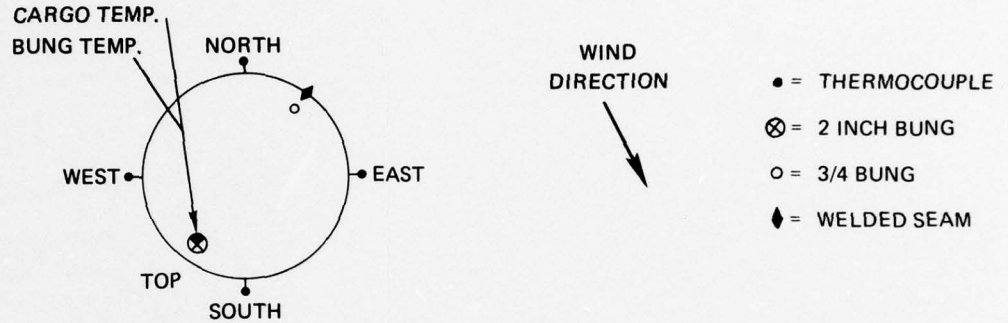

OTHER SENSORS:

Pressure transducer in 3/4 inch bung

Radiometer located at North end of fire pan 18' from fire edge

METHOD OF FAILURE:

FIRE BURNED OUT

TIME TO FAILURE (MIN:SEC):

16:0

PRESSURE AT FAILURE (PSIG):

25.3

COMMENTS:
SIDE

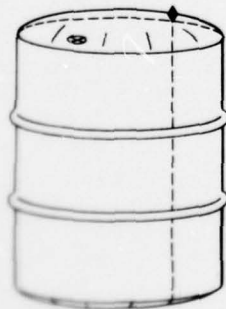

TOP

BOTTOM

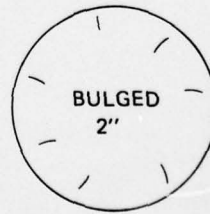

1. FIRE BURNED OUT AT 16:00
2. BOTTOM AND HEAD BULGED 2". EVIDENCE THAT UNROLLING HAD STARTED.

Z

DATA FROM TEST #13

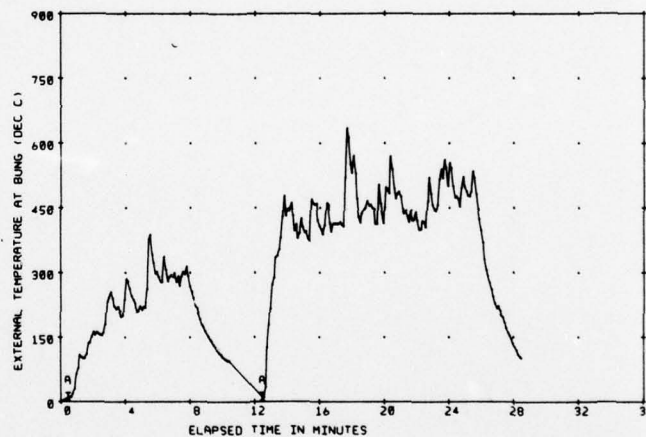
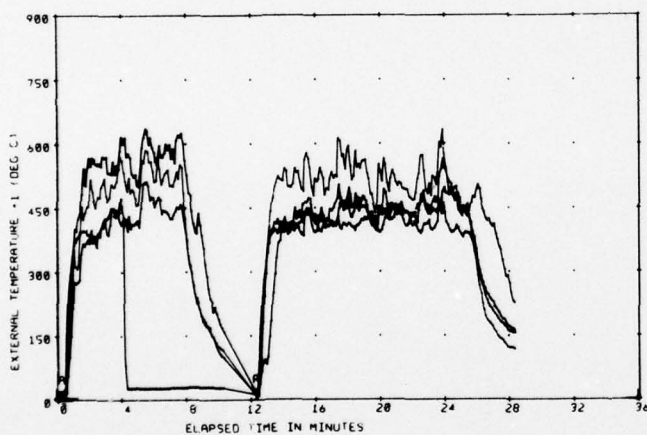
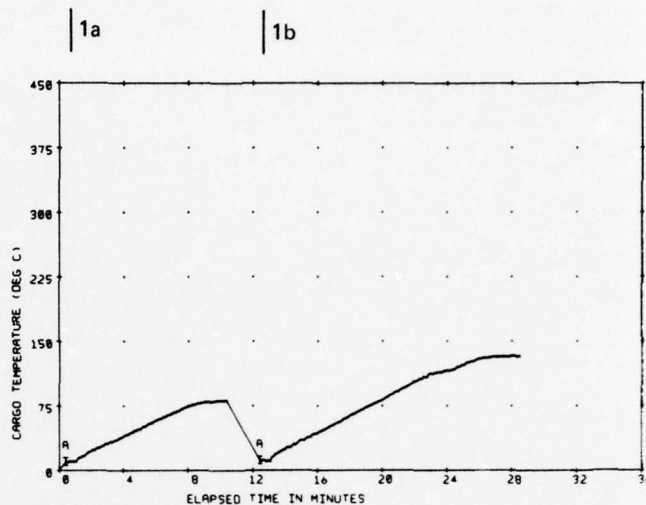
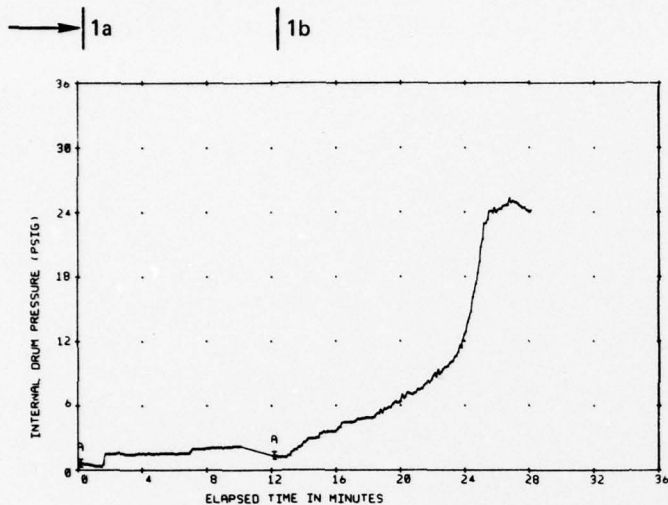

KEY:
A = IGNITION
B = FAILURE
C = VISIBLE FAILURE

PRECEDING PAGE BLANK-NOT FILMED

DRUM FIRE TESTS PHASE II

DATA FROM TEST NUMBER 14

DRUM SIZE: 55 GAL; MATERIAL: STEEL (17E)

FIRE SIZE: 90 SQ. FT.; INVOLVEMENT: FULL

CARGO: LUBRICATING OIL

14a THERMOCOUPLE ARRANGEMENT AND DRUM ORIENTATION

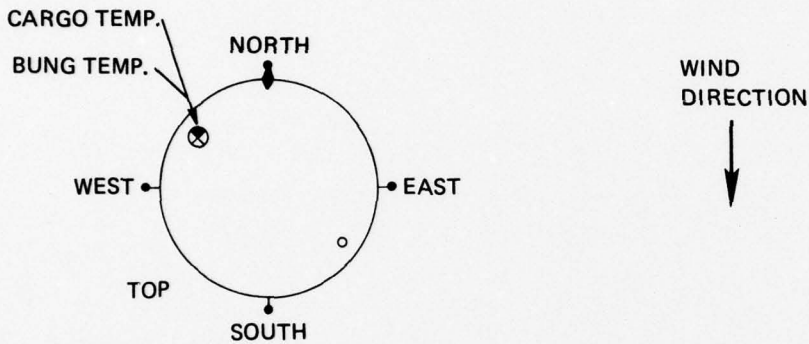

OTHER SENSORS:

Pressure transducer in 3/4 inch bung

Radiometer located at North end of fire pan 18' from fire edge

METHOD OF FAILURE:	JETTING	EXPLOSION
TIME TO FAILURE (MIN:SEC):	2:39	-
PRESSURE AT FAILURE (PSIG):	6.8	-

COMMENTS:
SIDE

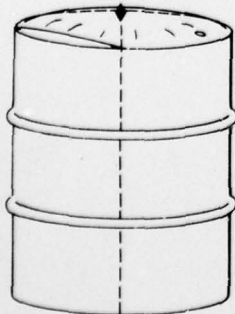

TOP



BOTTOM

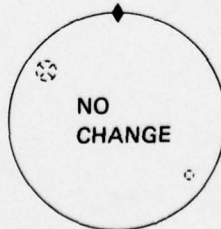

SEAM UNROLLED & LIFTED FOR 1/4 OF CIRCUMFERENCE

PRECEDING PAGE BLANK-NOT FILMED

14b THERMOCOUPLE ARRANGEMENT AND DRUM ORIENTATION

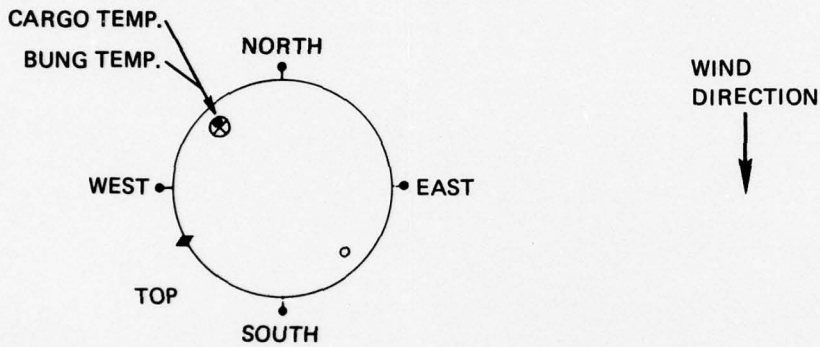

OTHER SENSORS:

Pressure transducer in 3/4 inch bung
 Radiometer located at North end of fire pan 18' from fire edge

METHOD OF FAILURE:	JETTING	EXPLOSION
TIME TO FAILURE (MIN:SEC):	1:31	-
PRESSURE AT FAILURE (PSIG):	5.5	-

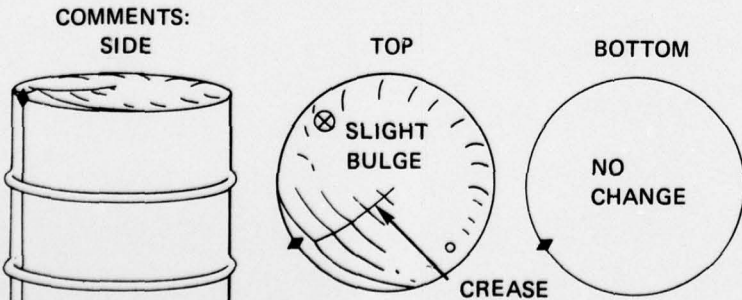

SEAM RIPPED OPEN
 FOR 2 FEET - CREASED UP
 2 INCHES. CARGO JETTED.

2

14c THERMOCOUPLE ARRANGEMENT AND DRUM ORIENTATION

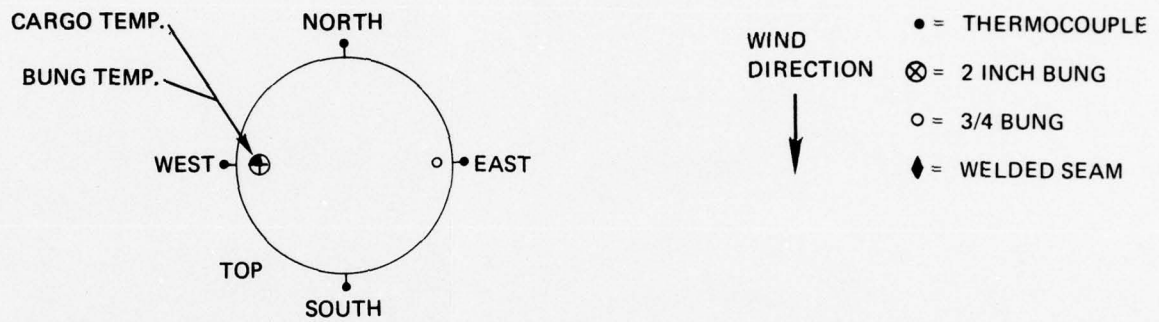

OTHER SENSORS:

Pressure transducer in 3/4 inch bung

Radiometer located at North end of fire pan 18' from fire edge

METHOD OF FAILURE:	JETTING	EXPLOSION
TIME TO FAILURE (MIN:SEC):	1:14	-
PRESSURE AT FAILURE (PSIG):	7.2	-

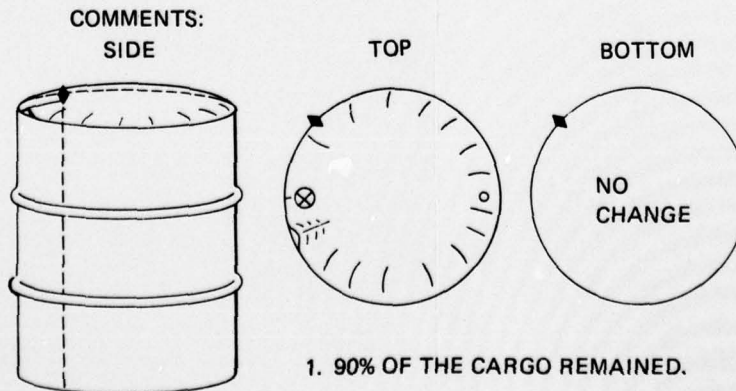

3

DATA FROM TEST #14

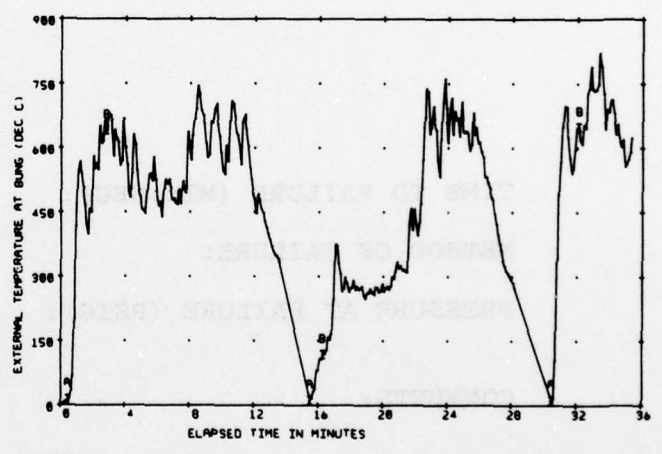
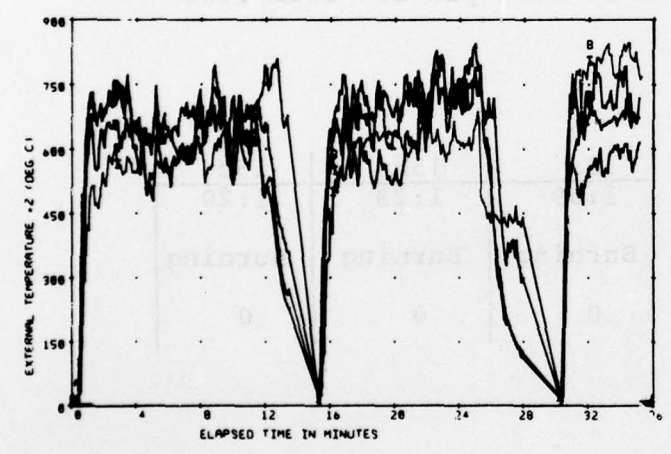
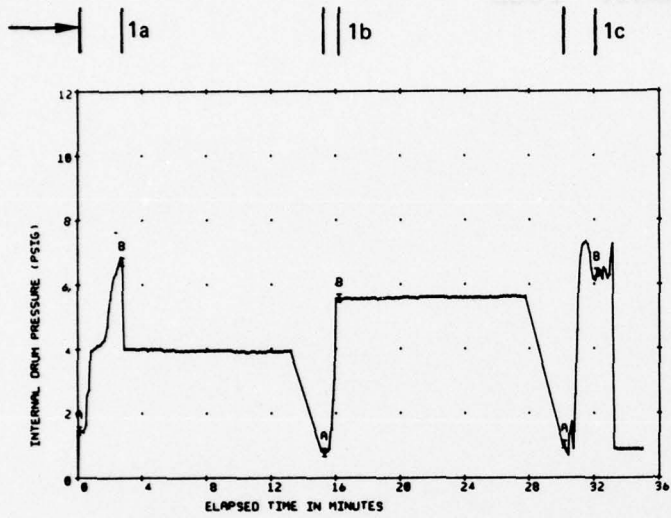

KEY:
 A = IGNITION
 B = FAILURE
 C = VISIBLE FAILURE

PRECEDING PAGE BLANK-NOT FILMED

DRUM FIRE TESTS PHASE II

DATA FROM TEST NUMBER 15

DRUM SIZE: 55 GAL; MATERIAL: POLYETHYLENE

FIRE SIZE: 90 SQ. FT.; INVOLVEMENT: FULL

CARGO: ETHYL ETHER

THERMOCOUPLE ARRANGEMENT:

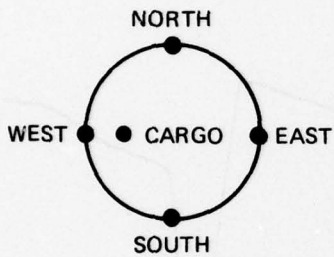

OTHER SENSORS:

Pressure transducer in drum

Radiometer located at North end of fire pan 18' from fire

TIME TO FAILURE (MIN:SEC):

METHOD OF FAILURE:

PRESSURE AT FAILURE (PSIG):

COMMENTS:

15a	15b	15c
1:09	1:23	1:20
Burning	Burning	Burning
0	0	0

DATA FROM TEST NUMBER 15

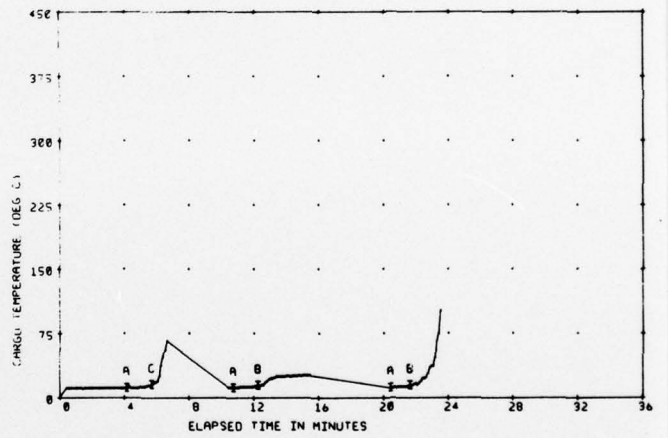
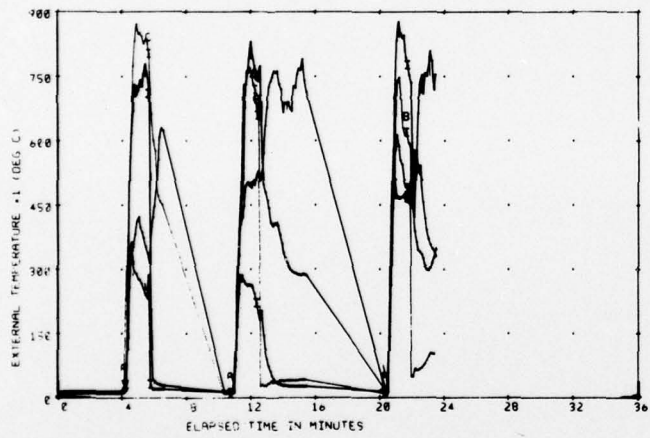
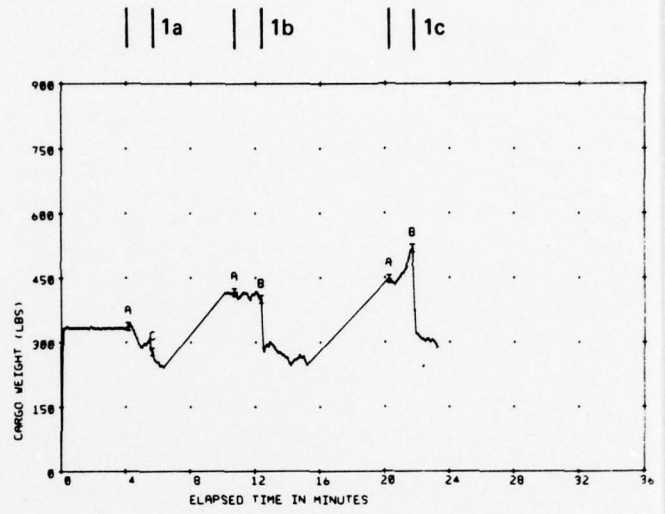
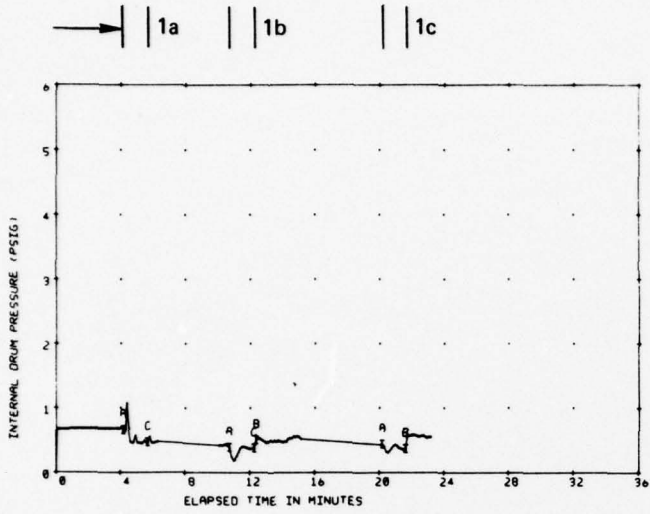

KEY:
 A = IGNITION
 B = FAILURE
 C = VISIBLE FAILURE

DRUM FIRE TESTS PHASE II

DATA FROM TEST NUMBER 16

DRUM SIZE: 55 GAL; MATERIAL: STEEL (5B)

FIRE SIZE: 90 SQ. FT.; INVOLVEMENT: FULL

CARGO: JP-4

16a THERMOCOUPLE ARRANGEMENT AND DRUM ORIENTATION

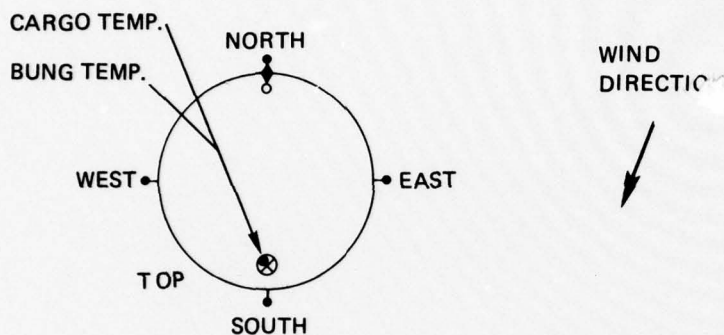

OTHER SENSORS:

Pressure transducer in 3/4 inch bung

Radiometer located at North end of fire pan 18' from fire edge

METHOD OF FAILURE:	JETTING	EXPLOSION
TIME TO FAILURE (MIN:SEC):	4:05	6:21
PRESSURE AT FAILURE (PSIG):	54.7	70.8

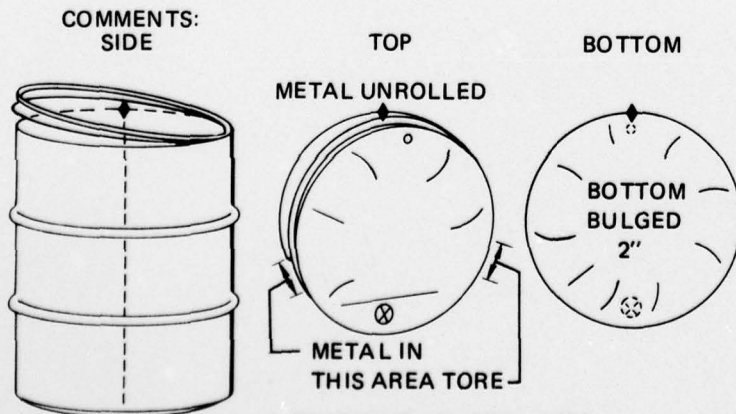

1. RING & HEAD SEPARATED
2. DRUM JETTED THEN EXPLODED AND PARTIALLY UNROLLED

PRECEDING PAGE BLANK - NOT FILMED

DRUM FIRE TESTS PHASE II

DATA FROM TEST NUMBER 16

DRUM SIZE: 55 GAL; MATERIAL: STEEL (5B)

FIRE SIZE: 90 SQ. FT.; INVOLVEMENT: FULL

CARGO: JP-4

16a THERMOCOUPLE ARRANGEMENT AND DRUM ORIENTATION

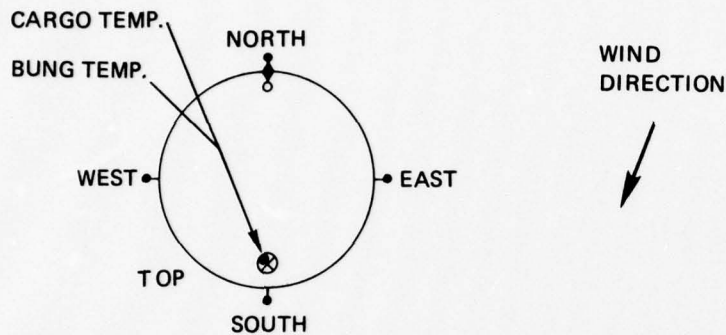

OTHER SENSORS:

Pressure transducer in 3/4 inch bung

Radiometer located at North end of fire pan 18' from fire edge

METHOD OF FAILURE:	JETTING	EXPLOSION
TIME TO FAILURE (MIN:SEC):	4:05	6:21
PRESSURE AT FAILURE (PSIG):	54.7	70.8

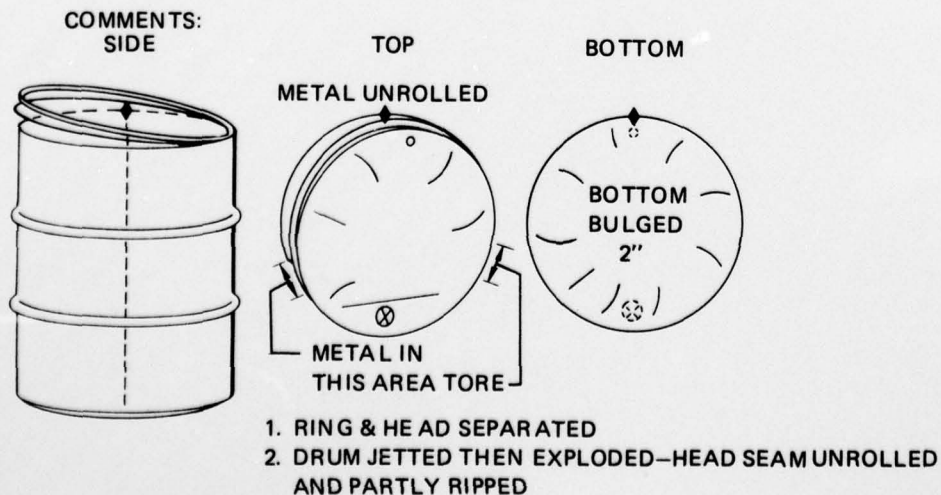

16b THERMOCOUPLE ARRANGEMENT AND DRUM ORIENTATION

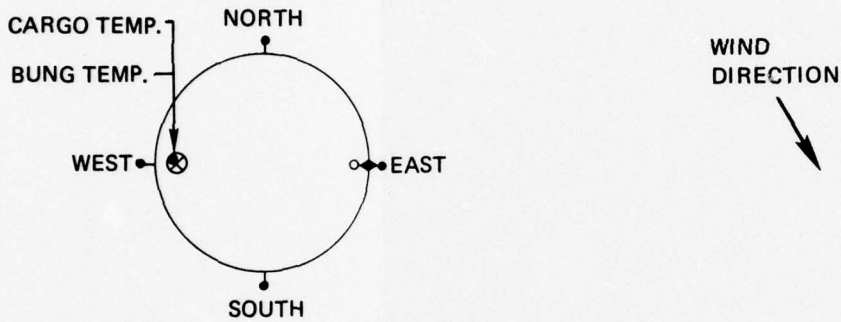

OTHER SENSORS:

Pressure transducer in 3/4 inch bung

Radiometer located at North end of fire pan 18' from fire edge

METHOD OF FAILURE:	JETTING	EXPLOSION
TIME TO FAILURE (MIN:SEC):	5:47/6:08	-
PRESSURE AT FAILURE (PSIG):	62.4/64.0	-

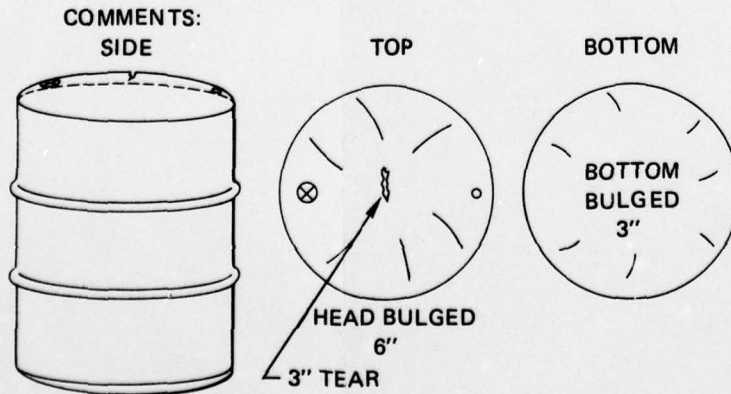

1. RING DISTORTED, BUT HELD
2. DRUM JETTED TO FAILURE

2

16c THERMOCOUPLE ARRANGEMENT AND DRUM ORIENTATION

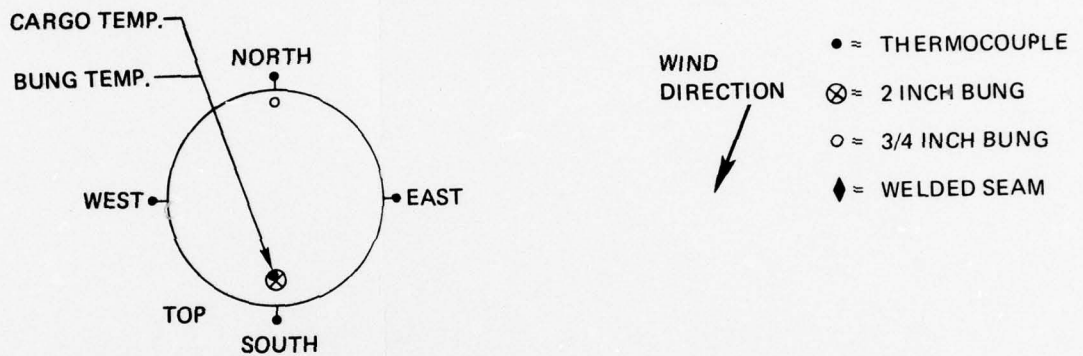

OTHER SENSORS:

Pressure transducer in 3/4 inch bung

Radiometer located at North end of fire pan 18' from fire edge

METHOD OF FAILURE:	JETTING	EXPLOSION
TIME TO FAILURE (MIN:SEC):	3:14/3:47	3:57
PRESSURE AT FAILURE (PSIG):	50.5/55.6	56.5

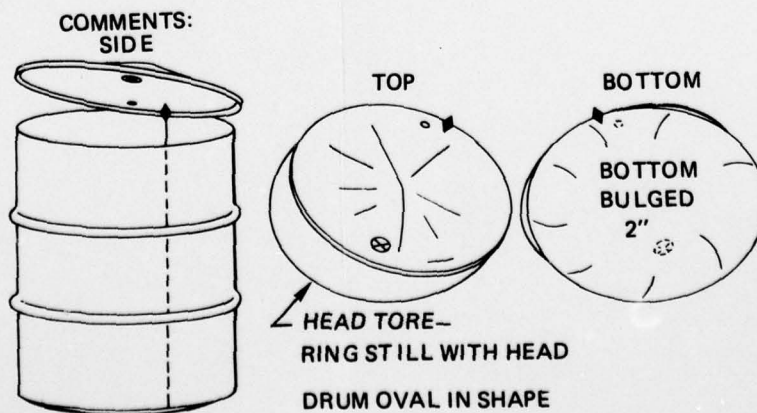

3

DATA FROM TEST #16

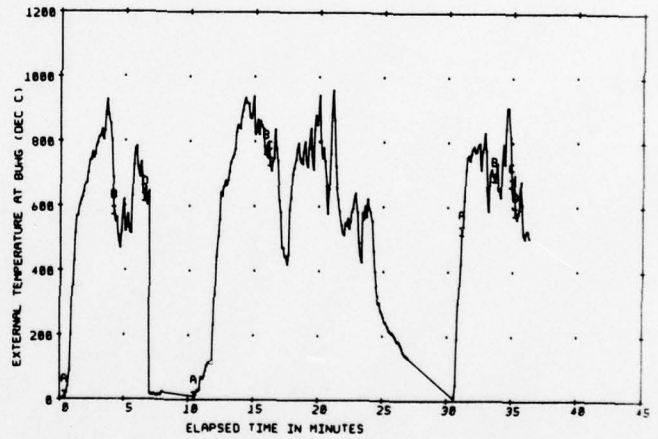
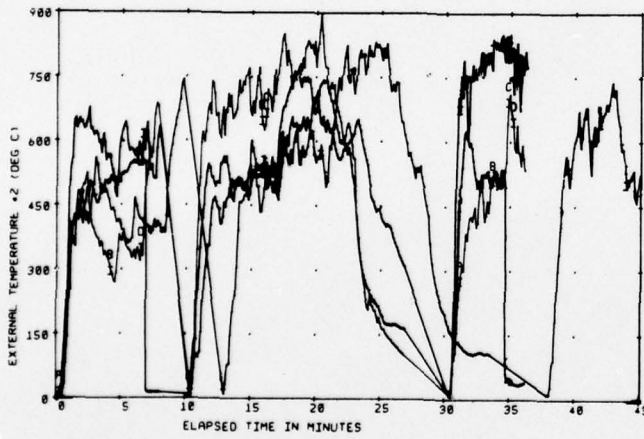
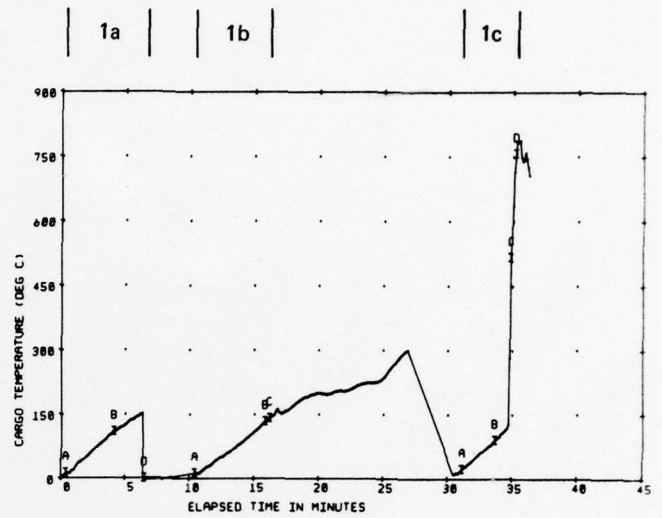
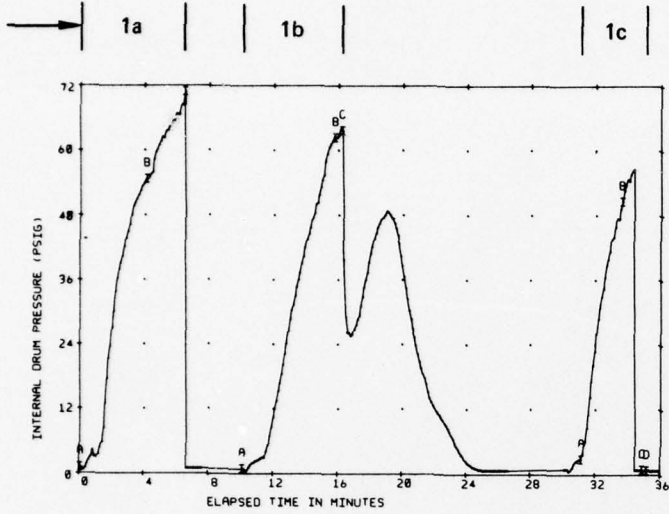

KEY:
 A = IGNITION
 B = FAILURE
 C = VISIBLE FAILURE

PRECEDING PAGE BLANK-NOT FILMED

DRUM FIRE TESTS PHASE II

DATA FROM TEST NUMBER 17

DRUM SIZE: 55 GAL; MATERIAL: STEEL (17E)

FIRE SIZE: 90 SQ. FT.; INVOLVEMENT: FULL

CARGO: ETHYL ETHER

17a THERMOCOUPLE ARRANGEMENT AND DRUM ORIENTATION

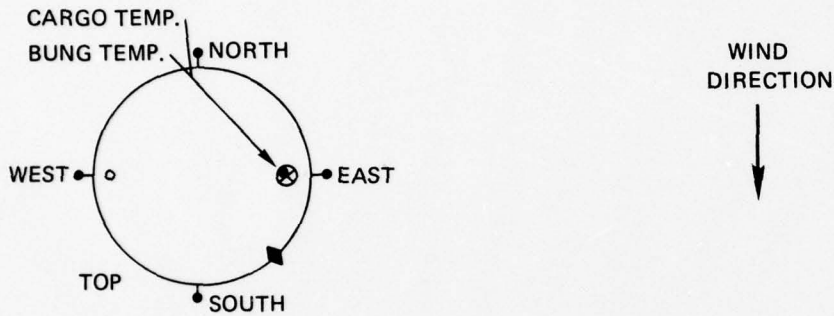

OTHER SENSORS:

Pressure transducer in 3/4 inch bung

Radiometer located at North end of fire pan 18' from fire edge

METHOD OF FAILURE:	JETTING	EXPLOSION
TIME TO FAILURE (MIN:SEC):	1:25	1:35
PRESSURE AT FAILURE (PSIG):	19.0	23.0

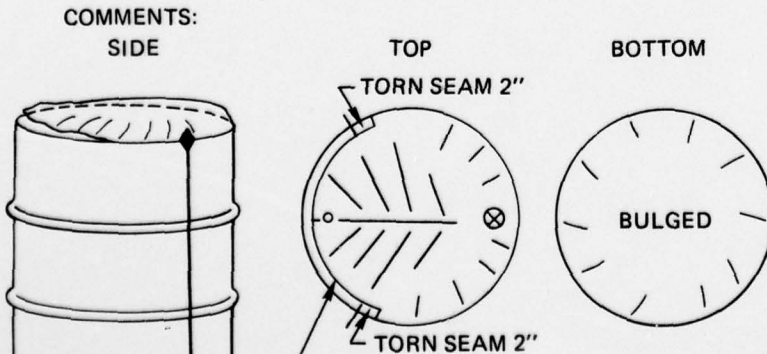

1. SMALL JET THEN DRUM BLEW
2. 1/3RD OF CARGO REMAINED IN DRUM AND BURNED OFF ABOVE THE DRUM
3. EXPLOSION WAS ACTUALLY A VIOLENT JET

AD-A052 436

COAST GUARD RESEARCH AND DEVELOPMENT CENTER GROTON CONN F/6 13/4
FIRE EXPOSURE TESTS OF POLYETHYLENE AND FIFTY-FIVE GALLON STEEL--ETC(U)
AUG 77 R C RICHARDS, G J MUNKENBECK

UNCLASSIFIED

COR/DC-20/77

USCG-D-86-77

NL

2 of 2
AD
A052436

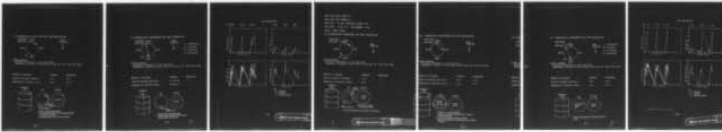

END
DATE
FILMED
5 -78
DDC

17b THERMOCOUPLE ARRANGEMENT AND DRUM ORIENTATION

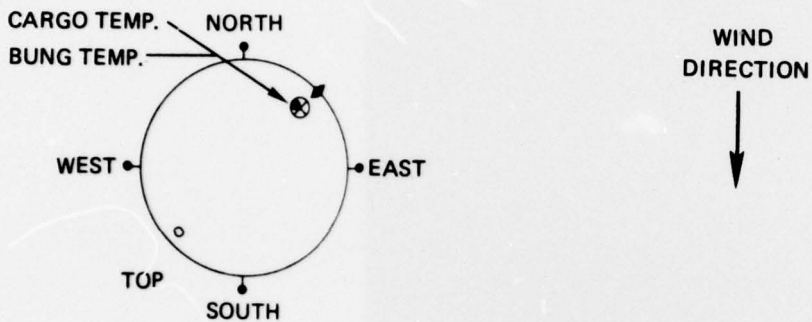

OTHER SENSORS:

Pressure transducer in 3/4 inch bung

Radiometer located at North end of fire pan 18' from fire edge

METHOD OF FAILURE:	JETTING	EXPLOSION
TIME TO FAILURE (MIN:SEC):	1:37	1:51
PRESSURE AT FAILURE (PSIG):	20.0	23.4

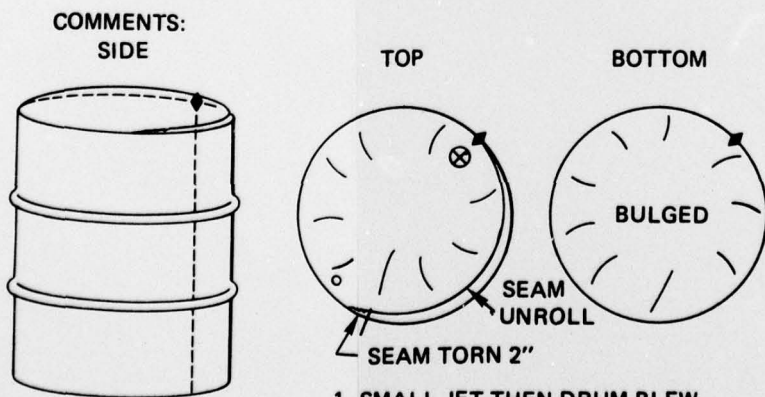

1. SMALL JET THEN DRUM BLEW
2. 1/3 OF CARGO REMAINED IN DRUM AND BURNED OFF ABOVE THE DRUM
3. EXPLOSION WAS ACTUALLY A VIOLENT JET

2

17c THERMOCOUPLE ARRANGEMENT AND DRUM ORIENTATION

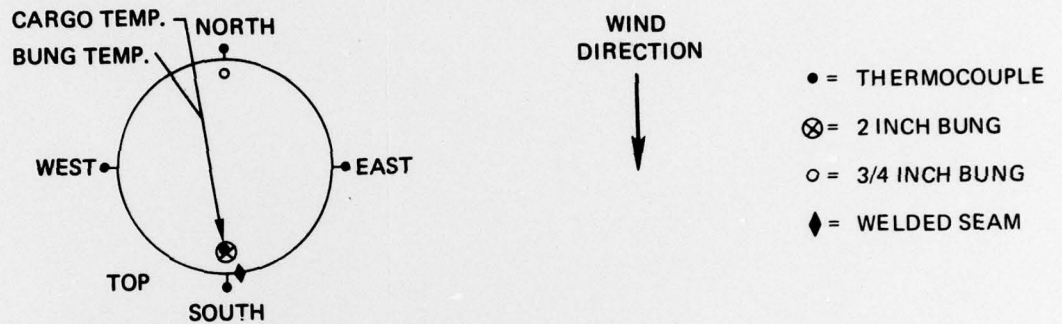

OTHER SENSORS:

Pressure transducer in 3/4 inch bung

Radiometer located at North end of fire pan 18' from fire edge

METHOD OF FAILURE:

JETTING

EXPLOSION

TIME TO FAILURE (MIN:SEC):

1:39/3:58

-

PRESSURE AT FAILURE (PSIG):

22.0/26.4

-

COMMENTS:

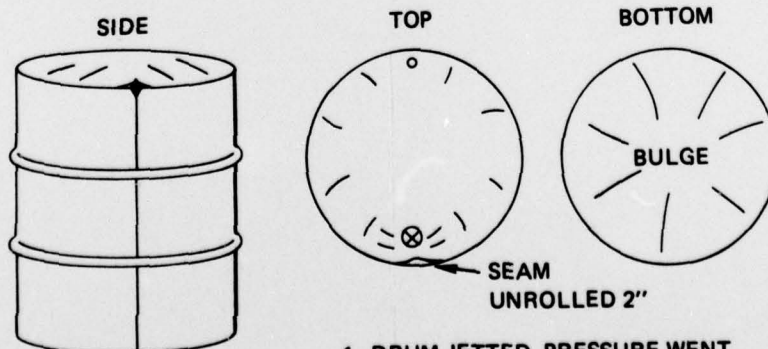

1. DRUM JETTED, PRESSURE WENT DOWN, THEN INCREASED AND STARTED SECOND MORE VIOLENT JET

5

DATA FROM TEST #17

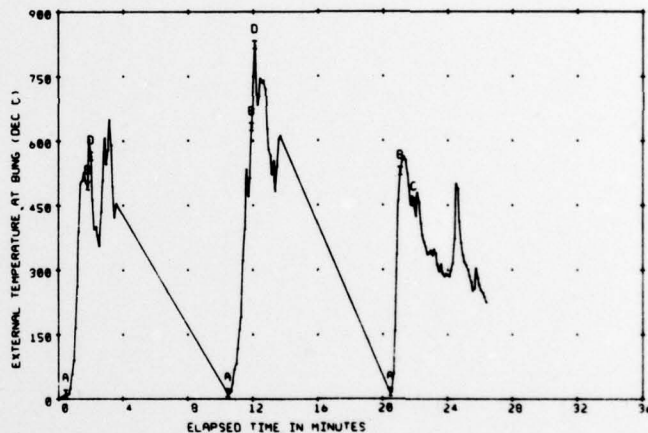
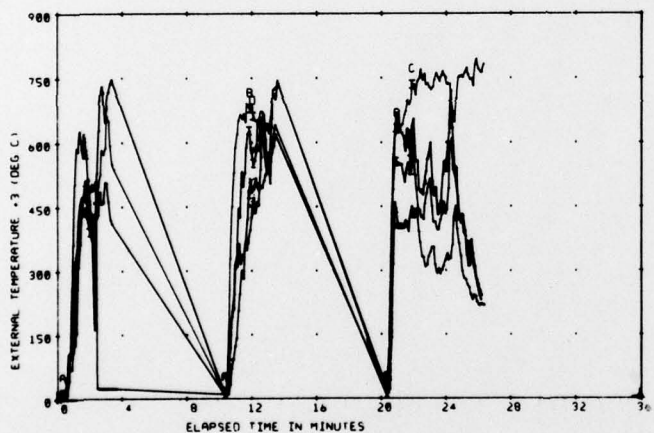
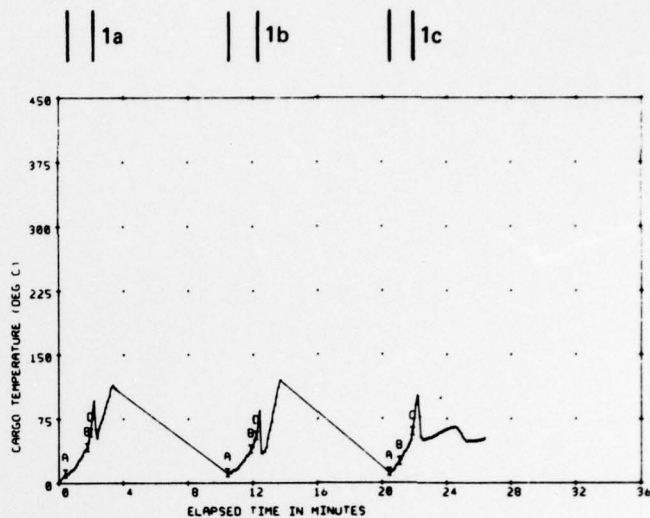
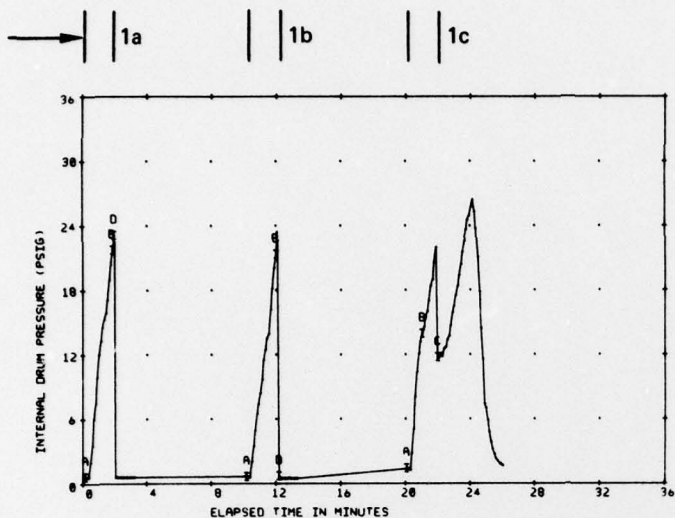

KEY:
 A = IGNITION
 B = FAILURE
 C = VISIBLE FAILURE

PRECEDING PAGE BLANK-NOT FILLED

DRUM FIRE TESTS PHASE II

DATA FROM TEST NUMBER 18

DRUM SIZE: 55 GAL; MATERIAL: STEEL (5B)

FIRE SIZE: 90 SQ. FT.; INVOLVEMENT: FULL

CARGO: ETHYL ETHER

18a THERMOCOUPLE ARRANGEMENT AND DRUM ORIENTATION

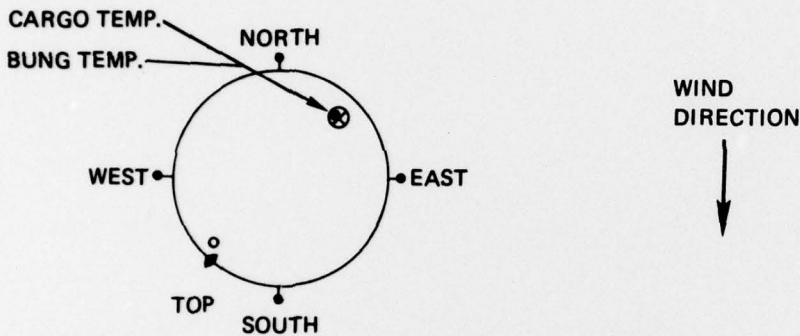

OTHER SENSORS:

Pressure transducer in 3/4 inch bung

Radiometer located at North end of fire pan 18' from fire edge

METHOD OF FAILURE:	JETTING	EXPLOSION
TIME TO FAILURE (MIN:SEC):	2:30	-
PRESSURE AT FAILURE (PSIG):	49.8	-

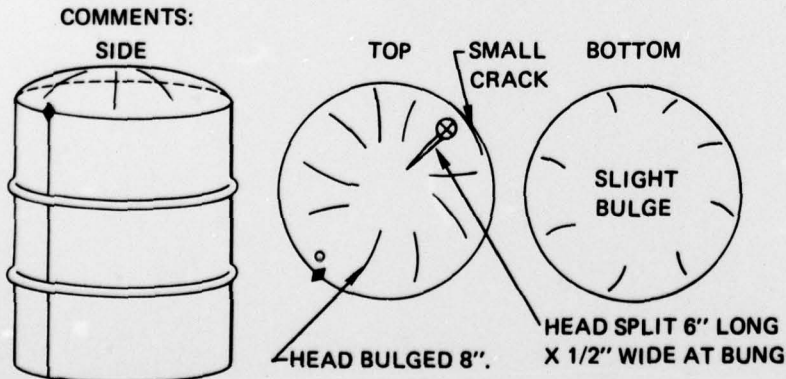

1. FAILURE PRODUCED JET 100' LONG, 75' IN HEIGHT.

18b THERMOCOUPLE ARRANGEMENT AND DRUM ORIENTATION

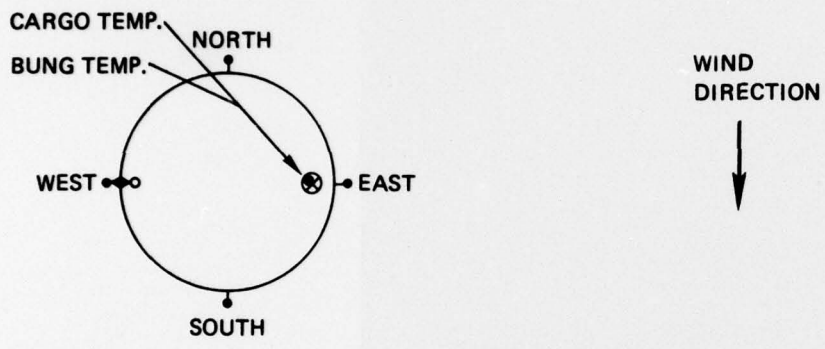

OTHER SENSORS:

Pressure transducer in 3/4 inch bung
 Radiometer located at North end of fire pan 18' from fire edge

METHOD OF FAILURE:	JETTING	EXPLOSION
TIME TO FAILURE (MIN:SEC):	0:56	2:25
PRESSURE AT FAILURE (PSIG):	14.4	53.5

COMMENTS:
SIDE

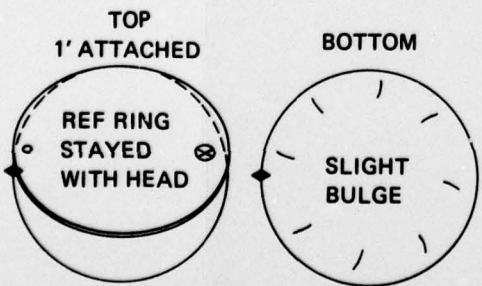
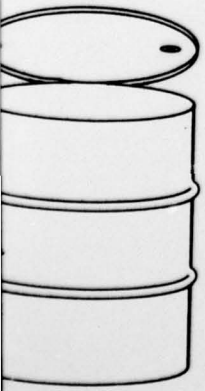

1. DRUM JETTED THEN EXPLODED, DRUM LAY AGAINST NE SIDE OF CAGE. FIRE BALL REACHED 150' HIGH.
2. ONLY 1' OF TOP WAS ATTACHED TO DRUM REMAINDER UNROLLED. RING WAS STILL ATTACHED TO HEAD.

2

18c THERMOCOUPLE ARRANGEMENT AND DRUM ORIENTATION

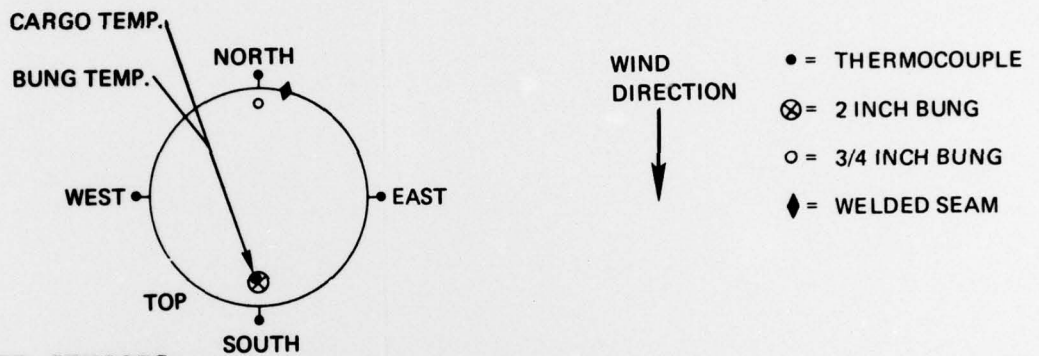

OTHER SENSORS:

Pressure transducer in 3/4 inch bung

Radiometer located at North end of fire pan 18' from fire edge

METHOD OF FAILURE:	JETTING	EXPLOSION
TIME TO FAILURE (MIN:SEC):	0:57	2:23
PRESSURE AT FAILURE (PSIG):	15.3	52.0

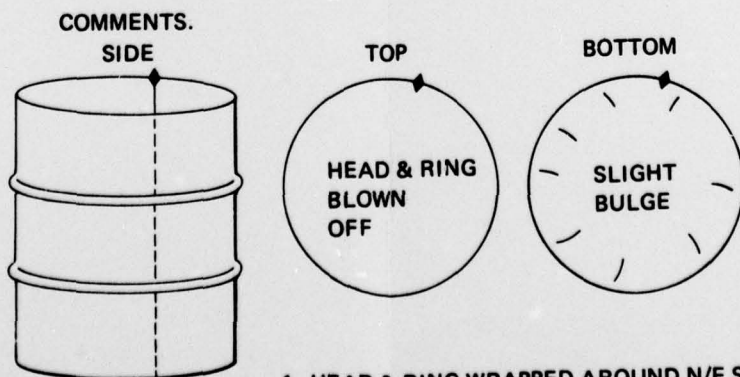

1. HEAD & RING WRAPPED AROUND N/E SIDE OF CAGE.

3

DATA FROM TEST #18

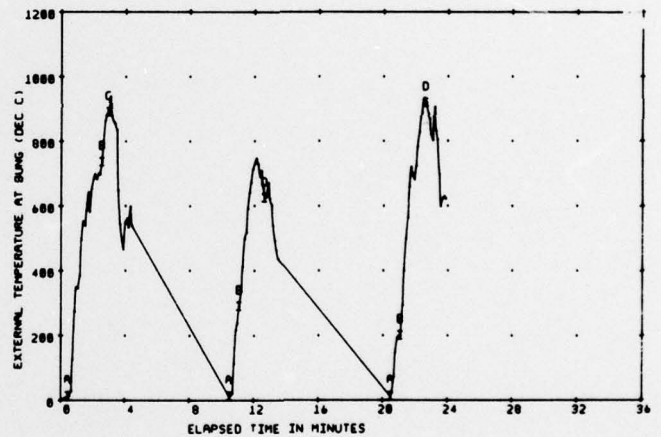
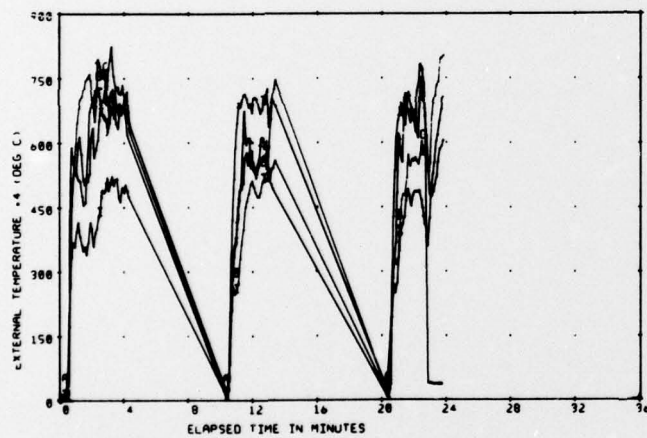
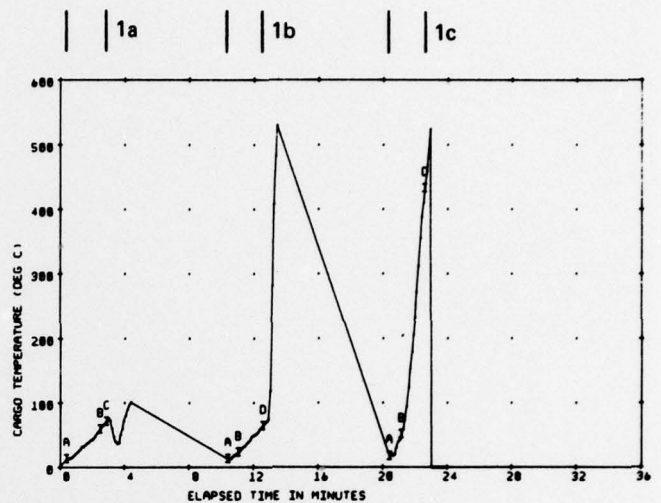
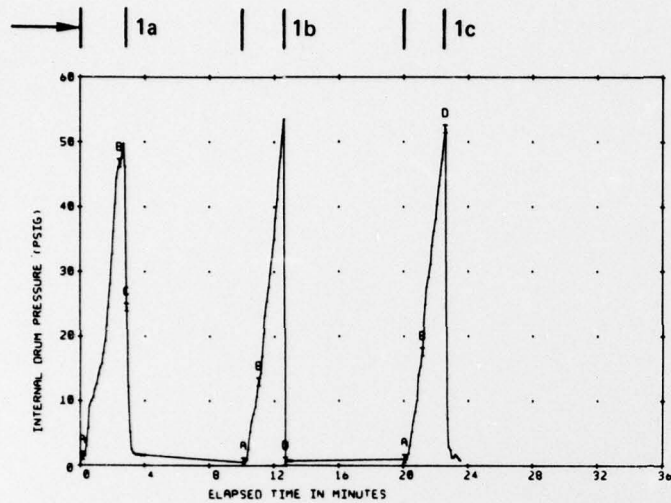

KEY:
 A = IGNITION
 B = FAILURE
 C = VISIBLE FAILURE

PRECEDING PAGE BLANK-NOT FILMED