

AD-A052 469

ARINC RESEARCH CORP ANNAPOLIS MD  
SHIP SYSTEMS DEFINITION AND INDEX (SWBS STAGING DIAGRAMS) FOR F--ETC(U)  
OCT 76

N00140-76-D-0813

F/G 13/10

NL

UNCLASSIFIED

1804-01-1-1547

1 OF 3  
ADA  
062 469

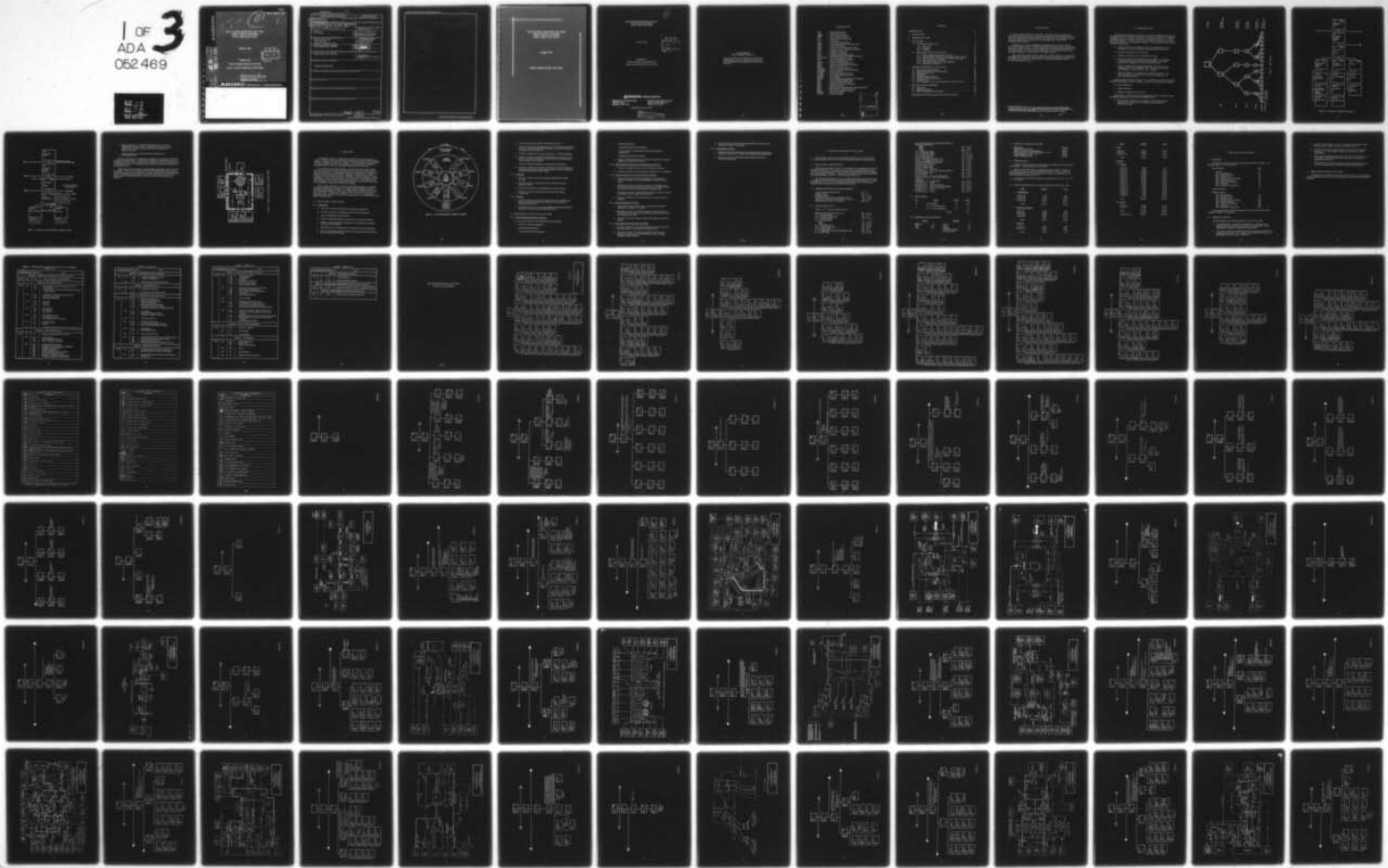

APSO

Publication 1804-01-1-1547

AD A 052469

*See back page for 1473*

*(11)*

*J*

SHIP SYSTEMS DEFINITION AND INDEX  
(SWBS STAGING DIAGRAMS)  
FOR FF-1052 CLASS SHIPS

October 1976

DDC  
RECEIVED  
APR 11 1978  
F

AD No. —  
DDC FILE COPY

Prepared for

PEARL HARBOR NAVAL SHIPYARD

Under Contract N00140-76-D-0813-0004

This document has been approved  
for public release and sale; its  
distribution is unlimited.

**ARINC** RESEARCH CORPORATION



UNCLASSIFIED

SECURITY CLASSIFICATION OF THIS PAGE (When Data Entered)

REPORT DOCUMENTATION PAGE		READ INSTRUCTIONS BEFORE COMPLETING FORM
1. REPORT NUMBER 14 1804-01-1-1547	2. GOVT ACCESSION NO.	3. RECIPIENT'S CATALOG NUMBER
6 TITLE (and Subtitle) SHIP SYSTEMS DEFINITION AND INDEX (SWBS STAGING DIAGRAMS) FOR FF-1052 CLASS SHIPS.		5. TYPE OF REPORT & PERIOD COVERED
7. AUTHOR(s) NOT LISTED		6. PERFORMING ORG. REPORT NUMBER 1804-01-1-1547
9. PERFORMING ORGANIZATION NAME AND ADDRESS ARINC Research Corp. 2551 Riva Road Annapolis, Maryland 21401		8. CONTRACT OR GRANT NUMBER(s) 15 <del>NO</del> 140-76-D-0813-0004 ✓
11. CONTROLLING OFFICE NAME AND ADDRESS PEARL HARBOR NAVAL SHIPYARD		10. PROGRAM ELEMENT, PROJECT, TASK AREA & WORK UNIT NUMBERS 12 256p.
14. MONITORING AGENCY NAME & ADDRESS (if different from Controlling Office) PEARL HARBOR NAVAL SHIPYARD		12. REPORT DATE 11 Oct 1976 ✓
16. DISTRIBUTION STATEMENT (of this Report)  UNCLASSIFIED/UNLIMITED		13. NUMBER OF PAGES 129
17. DISTRIBUTION STATEMENT (of the abstract entered in Block 20, if different from Report)		14. SECURITY CLASS. (of this report!) UNCLASSIFIED
18. SUPPLEMENTARY NOTES		15a. DECLASSIFICATION/DOWNGRADING SCHEDULE
19. KEY WORDS (Continue on reverse side if necessary and identify by block number)		
20. ABSTRACT (Continue on reverse side if necessary and identify by block number)		

400 247 JW

<p>REPORT NUMBER 1801-01-1-1217</p>	<p>REPORT DOCUMENTATION PAGE</p>
<p>DATE OF REPORT (Month/Year) October 1976</p>	<p>1801-01-1-1217</p>
<p>REPORT TYPE AND PERIODICITY Final Report</p>	<p>SHIP CYCLING DEFINITION AND INDEX (SHIP CYCLING TABLES) FOR EX-1025 CLASS SHIPS</p>
<p>PERFORMING ORGANIZATION NAME(S) AND ADDRESS(ES) ARINC Research Corp. 2221 Riva Road Annapolis, Maryland 21401</p>	<p>1801-01-1-1217</p>
<p>PERFORMING ORGANIZATION REPORT NUMBER 1801-01-1-1217</p>	<p>NOT LISTED</p>
<p>PERFORMING ORGANIZATION REPORT NUMBER 1801-01-1-1217</p>	<p>ARINC Research Corp. 2221 Riva Road Annapolis, Maryland 21401</p>
<p>PERFORMING ORGANIZATION REPORT NUMBER 1801-01-1-1217</p>	<p>ARINC Research Corp. 2221 Riva Road Annapolis, Maryland 21401</p>
<p>PERFORMING ORGANIZATION REPORT NUMBER 1801-01-1-1217</p>	<p>ARINC Research Corp. 2221 Riva Road Annapolis, Maryland 21401</p>
<p>PERFORMING ORGANIZATION REPORT NUMBER 1801-01-1-1217</p>	<p>ARINC Research Corp. 2221 Riva Road Annapolis, Maryland 21401</p>
<p>PERFORMING ORGANIZATION REPORT NUMBER 1801-01-1-1217</p>	<p>ARINC Research Corp. 2221 Riva Road Annapolis, Maryland 21401</p>
<p>PERFORMING ORGANIZATION REPORT NUMBER 1801-01-1-1217</p>	<p>ARINC Research Corp. 2221 Riva Road Annapolis, Maryland 21401</p>
<p>PERFORMING ORGANIZATION REPORT NUMBER 1801-01-1-1217</p>	<p>ARINC Research Corp. 2221 Riva Road Annapolis, Maryland 21401</p>
<p>PERFORMING ORGANIZATION REPORT NUMBER 1801-01-1-1217</p>	<p>ARINC Research Corp. 2221 Riva Road Annapolis, Maryland 21401</p>
<p>PERFORMING ORGANIZATION REPORT NUMBER 1801-01-1-1217</p>	<p>ARINC Research Corp. 2221 Riva Road Annapolis, Maryland 21401</p>
<p>PERFORMING ORGANIZATION REPORT NUMBER 1801-01-1-1217</p>	<p>ARINC Research Corp. 2221 Riva Road Annapolis, Maryland 21401</p>
<p>PERFORMING ORGANIZATION REPORT NUMBER 1801-01-1-1217</p>	<p>ARINC Research Corp. 2221 Riva Road Annapolis, Maryland 21401</p>
<p>PERFORMING ORGANIZATION REPORT NUMBER 1801-01-1-1217</p>	<p>ARINC Research Corp. 2221 Riva Road Annapolis, Maryland 21401</p>
<p>PERFORMING ORGANIZATION REPORT NUMBER 1801-01-1-1217</p>	<p>ARINC Research Corp. 2221 Riva Road Annapolis, Maryland 21401</p>
<p>PERFORMING ORGANIZATION REPORT NUMBER 1801-01-1-1217</p>	<p>ARINC Research Corp. 2221 Riva Road Annapolis, Maryland 21401</p>
<p>PERFORMING ORGANIZATION REPORT NUMBER 1801-01-1-1217</p>	<p>ARINC Research Corp. 2221 Riva Road Annapolis, Maryland 21401</p>
<p>PERFORMING ORGANIZATION REPORT NUMBER 1801-01-1-1217</p>	<p>ARINC Research Corp. 2221 Riva Road Annapolis, Maryland 21401</p>
<p>PERFORMING ORGANIZATION REPORT NUMBER 1801-01-1-1217</p>	<p>ARINC Research Corp. 2221 Riva Road Annapolis, Maryland 21401</p>
<p>PERFORMING ORGANIZATION REPORT NUMBER 1801-01-1-1217</p>	<p>ARINC Research Corp. 2221 Riva Road Annapolis, Maryland 21401</p>

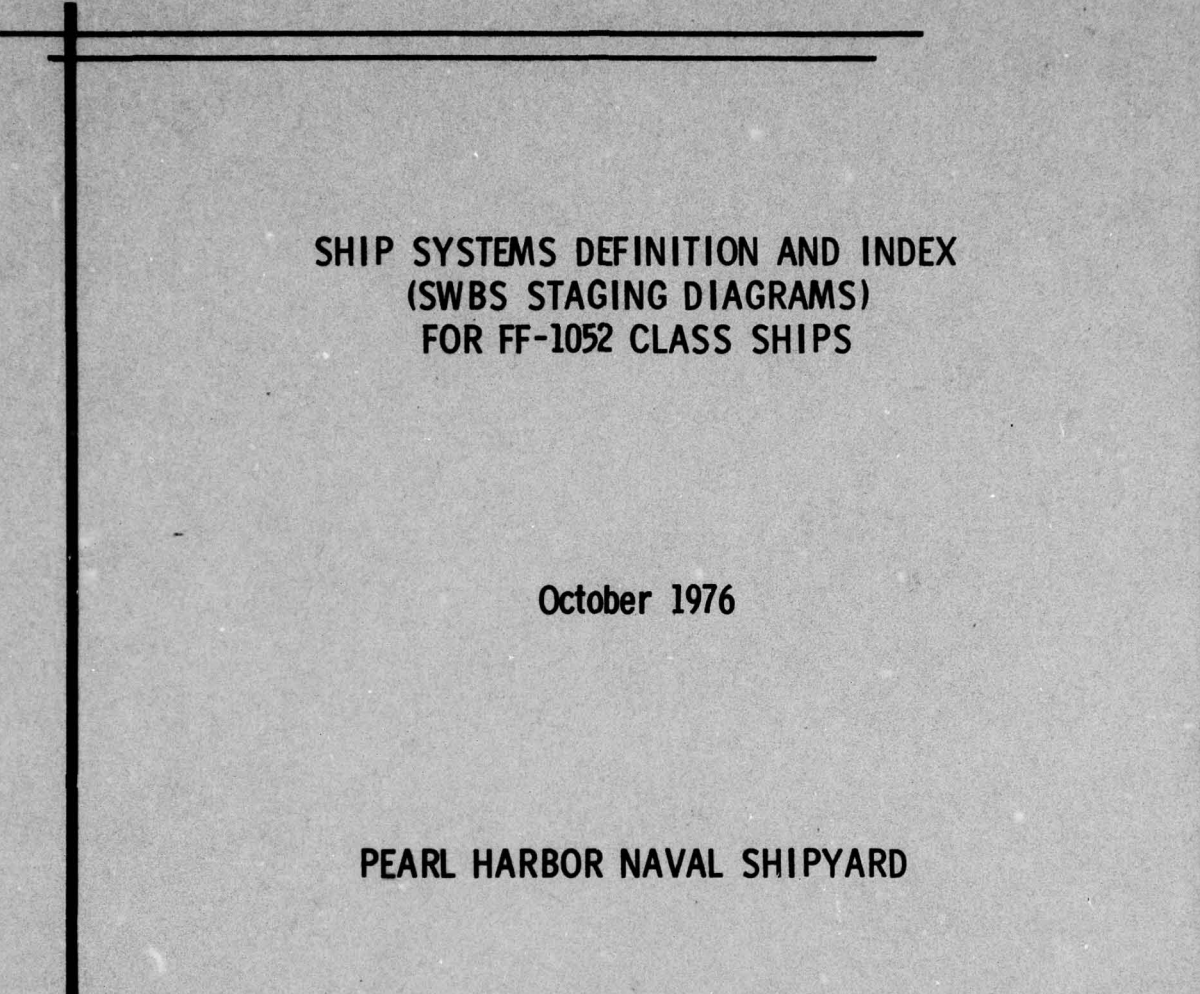

**SHIP SYSTEMS DEFINITION AND INDEX  
(SWBS STAGING DIAGRAMS)  
FOR FF-1052 CLASS SHIPS**

**October 1976**

**PEARL HARBOR NAVAL SHIPYARD**

11

SHIP SYSTEMS DEFINITION AND INDEX  
(SWBS STAGING DIAGRAMS)  
FOR FF-1052 CLASS SHIPS

October 1976

DDC  
RECEIVED  
APR 11 1978  
F

Prepared for  
PEARL HARBOR NAVAL SHIPYARD  
Under Contract N00140-76-D-0813-0004

 **ARINC** RESEARCH CORPORATION

**CORPORATE HEADQUARTERS**  
2551 Riva Road  
Annapolis, MD 21401

**HONOLULU SUPPORT OFFICE**  
245 Fort Street, Suite 211  
Honolulu, HI 96801

Publication 1804-01-1-1547

This document has been approved  
for public release and sale; its  
distribution is unlimited.

Copyright © 1976  
ARINC Research Corporation

Prepared under Contract N00140-76-D-0813-0004,  
which grants to the U.S. Government a license to  
use any material in this publication for government  
purposes.

## ABBREVIATIONS

A. P.	- After Perpendicular
APL	- Approved Parts List
ASROC	- Anti-Submarine Rocket
ASW	- Anti-Submarine Warfare
CDC	- Component Dictionary Code
C. L.	- Centerline
CNO	- Chief of Naval Operations
COSAL	- Coordinated Shipboard Allowance List
CPO	- Chief Petty Officer
CSMP	- Current Ship's Maintenance Project
DART	- Detection, Action, Response Technique
DoD	- Department of Defense
D. W. L.	- Designer's Waterline
EIC	- Equipment Identification Code
EOSS	- Equipment Operational Sequencing System
FLT CINCS	- Fleet Commanders-in-Chief
FMP	- Fleet Modernization Program
F. P.	- Forward Perpendicular
INSURV	- Board of Inspection and Survey
MDCS	- Maintenance Data Collection System
MOTU	- Mobile Technical Unit
NAVAIR	- Naval Air Systems Command
NAVELEX	- Naval Electronics Systems Command
NAVPERS	- Naval Personnel
NAVSEA	- Naval Sea Systems Command
NAVSEC	- Naval Ships Engineering Center
NAVSUP	- Naval Supply
NMMFO	- Navy Maintenance Management Field Office
NOSO	- Naval Ordnance Support Office
PMS	- Planned Maintenance System
POT&I	- Preoverhaul Test and Inspection
ROH	- Regular Overhaul
SECAS	- Ship Equipment Configuration Accounting System
SSDI	- Ship Systems Definition and Index
SWBS	- Ship Work Breakdown Structure
SYSCOM	- Systems Command
TYCOM	- Type Commander

ACCESSION for	
NTIS	Write Section <input checked="" type="checkbox"/>
DDC	Buff Section <input type="checkbox"/>
UNANNOUNCED	<input type="checkbox"/>
NOTIFICATION	
DISTRIBUTION/AVAILABILITY CODES	
and/or SPECIAL	
A	

CONTENTS

ABBREVIATIONS . . . . .	iii
1. INTRODUCTION . . . . .	1
2. PROPERTIES OF SSDI . . . . .	3
3. USES OF SSDI . . . . .	9
3.1 SSDI Support to Ship's Force . . . . .	9
3.1.1 Maintenance . . . . .	9
3.1.2 Operation . . . . .	11
3.1.3 Training . . . . .	11
3.2 SSDI Support to Other Naval Activities . . . . .	11
3.2.1 PERAs/Shipyards/Industrial Activities . . . . .	11
3.2.2 Ship Equipment Configuration Accounting System (SECAS) . . . . .	12
3.2.3 Technical Systems Commands (NAVSEA, NAVELEX) . . . . .	12
3.2.4 Type Commanders (TYCOMs) . . . . .	12
3.2.5 Naval Ships Engineering Center (NAVSEC) . . . . .	12
3.2.6 Fleet Support Activities . . . . .	13
4. GENERAL INFORMATION, FF-1052 CLASS . . . . .	15
4.1 Basis of Hull Measurements . . . . .	15
4.2 General Dimensions and Characteristics . . . . .	15
4.3 Heights Above D. W. L. . . . .	15
4.4 Small Boats . . . . .	16
4.5 Berthing Accommodations . . . . .	16
4.6 Capacity of Booms and Cranes . . . . .	17
4.7 Frame Spacing . . . . .	17
4.8 Tank Capacities at Full Load Conditions for FF-1052 - 1077 . . . . .	17
5. SSDI FOR FF-1052 CLASS SHIPS . . . . .	19
5.1 SSDI Index . . . . .	19
5.2 General Comments . . . . .	19
5.3 SWBS Classifications Not Included . . . . .	20
Ship Systems Definition and Index for FF-1052 Class Ships . . . . .	25

## 1. INTRODUCTION

Under Contract N00140-76-D-0813-0004, ARINC Research Corporation was tasked to revise the FF-1052 Class Ship System Definition and Index (SSDI) issued in April 1975 to incorporate changes resulting from experience in its application, and to revise the equipment-level code numbers in accordance with a newly issued Component Code Dictionary.

The SSDI is an orderly identification and structuring of the systems and sub-systems that make up a ship. In defining ship systems as well as their boundaries and interfaces, the SSDI provides a common language for communicating information about ship configurations. The SSDI is thus useful to many naval activities involved in the operation, maintenance, modernization, and support of ships.

This report discusses the general properties of SSDI's (Section 2), describes the ways SSDI's can be utilized by the various Navy activities (Section 3), provides general information on FF-1052 class ships (Section 4), and presents the SSDI's for the FF-1052 class (Section 5). ↑

\*ARINC Research Corporation, Ship Systems Definition and Index (SWBS Staging Diagrams) for DE-1052 Class Ships, Publication 1630-01-1-1389, April 1975. Prepared for Pearl Harbor Naval Shipyard under Contract N00604-75-C-0276.

## 2. PROPERTIES OF SSDI

The Ship Systems Definition and Index is an orderly description of the systems that make up a ship. The SSDI is structured such that the summation of its diagrammed items at any level defines the total ship, as illustrated in Figure 1. An actual application of Figure 1, showing a typical ship breakdown from the major system to the sub-subsystem level, is presented in Figure 2. As demonstrated by these figures, the SSDI is structured to:

- a. Provide a multi-level breakdown of the ship's configuration, thereby providing for visibility and control at any desired level of detail.
- b. Completely define the ship at each level.
- c. Contain no redundancies in its definition of the ship.
- d. Utilize the Ships Work Breakdown Structure (SWBS). This provides a standard language based on the same nomenclature and coding system that is mandatory for use on a Navy-wide basis.
- e. Utilize a standard Navy Component Dictionary Code (CDC) list for assigning fifth-level identification codes. The last two characters of the identifier are from this list, e.g., 2551M7.
- f. Tailor the SWBS to the configuration of a specific ship class. The ship class diagram can in turn be tailored to the configuration of each ship within the class.

Figure 3 extends a portion of Figure 2 to an additional level of detail to demonstrate the information provided in the SSDI. As shown, the following are identified:

- a. System equipments
- b. System boundaries
- c. Shipboard maintenance work centers.

In some cases, notably for the more complicated systems, the SSDI provides still further information in the form of line diagrams that:

- a. Show the major hardware items within the system boundaries and their physical relationship— for example, the connecting of a turbine to its pump.

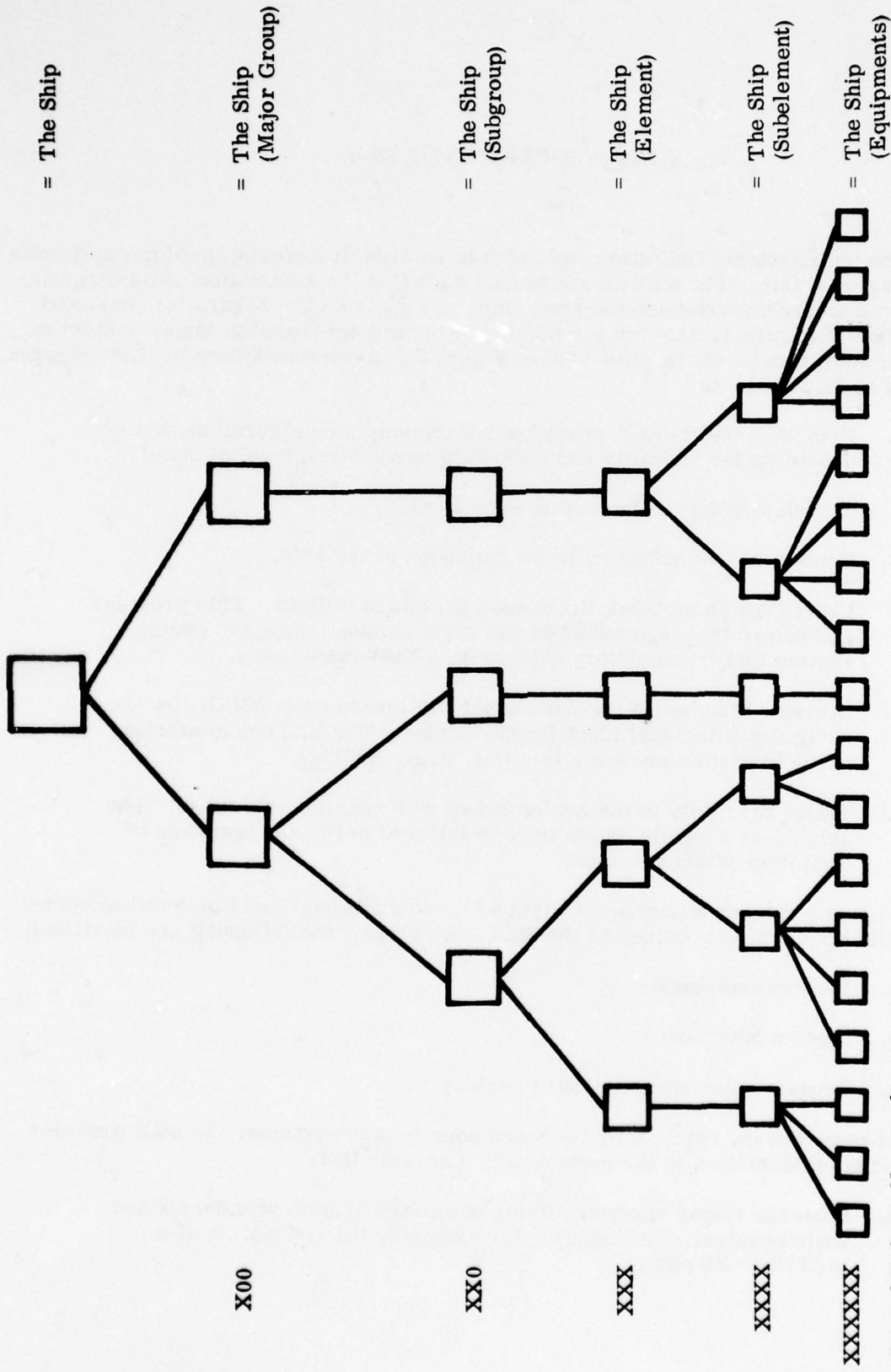

Figure 1. SSDI Concept

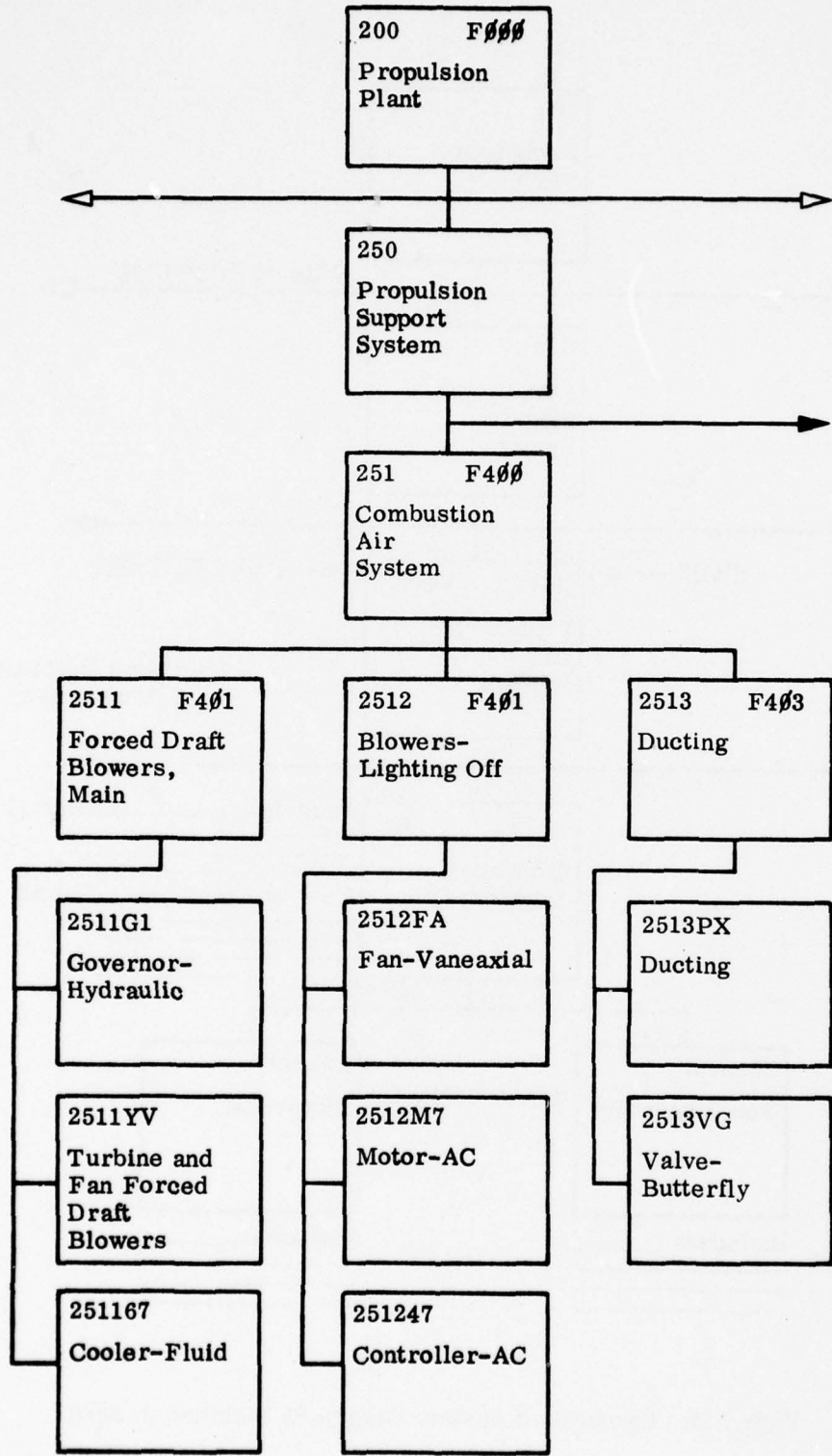

Figure 2. Portion of a Typical Ship's System

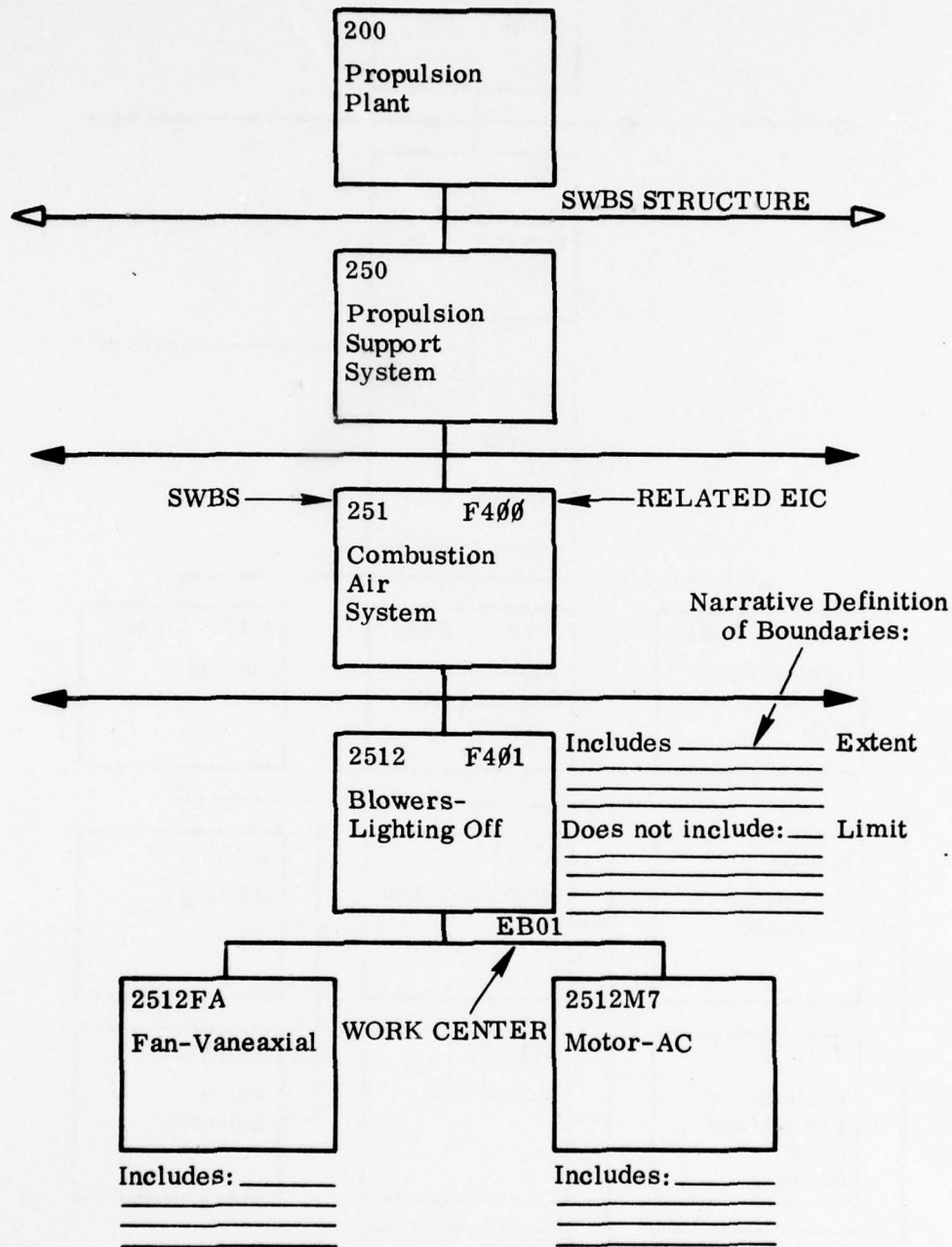

Figure 3. Example of System Diagrams Included in SSDI

- b. Depict graphically the verbal description shown on the system diagrams for selected SWBSs. Those systems which are complex and interface with other complex systems are diagrammed as Figure 4 indicates.
- c. Graphically depict the selected system's boundaries and interrelated SWBSs.

Within a line diagram, all equipment or components represented by solid lines belong to a particular system. Equipment or components represented by broken or dashed lines, even if located within the system boundary, are part of another system. As illustrated in Figure 4, tracing these lines to the system boundary will show the interfacing systems.

While some of the line diagrams show functional relationships, that is not their basic intent. Their primary purpose is to aid in the identification of ship systems. To expedite this process, the diagrams are greatly simplified from the actual configuration. For example, although there may be two or more identical forced-draft blowers used in a condensate system, only one is shown on the schematic (see Figure 4).

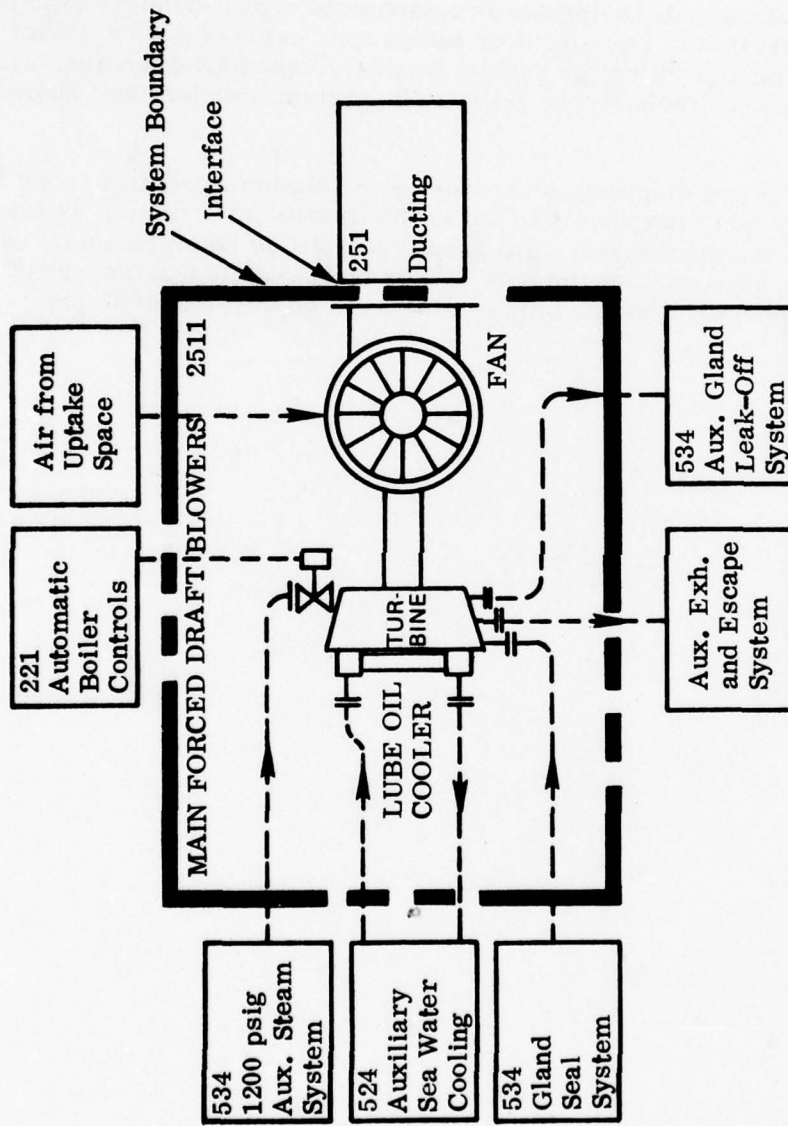

Figure 4. Example of Line Diagrams Included in SSDI

### 3. USES OF SSDI

Throughout a ship's life, ship's force personnel submit a vast amount of system, equipment, and parts information to their type commander and fleet support activities. Requests for alteration, reports of maintenance action, work requests, and parts requisitions are but a few examples. In each instance the submitted information must be related to a specific, definable portion of the ship.

In carrying out their responsibilities, the type commander and the support activities must not only identify a specific item within the total ship, but also be aware of its interfaces. In planning alterations or modifications, for example, the technical systems commands (NAVSEA, NAVELEX, NAVAIR) must be able to identify the various systems that will be affected by a particular change to a ship's configuration. Also, when preparing for overhaul or other availabilities, the type commander and repair activities must be able to organize a work package on the basis of specific as well as interrelated ship systems. This is done to ensure that the work package is completely and effectively defined.

Since so many activities are involved in supporting the ship, it is necessary that both ship and support personnel use a single, uniform language when communicating configuration information. The Ship Systems Definition and Index provides this common language by describing a specific ship in terms common to all ships of the fleet. As illustrated in Figure 5, it is a means of communicating information about a ship in a way that can be understood by all. Potential uses of the SSDI are outlined below.

#### 3.1 SSDI SUPPORT TO SHIP'S FORCE

##### 3.1.1 Maintenance

- a. Serves as a checklist for planning and conducting inspections.
- b. Provides the basis for comparing repair items with alterations.
- c. Aids in establishing repair priorities.
- d. Assists in identifying shipyard, ship's force, and tender interfaces.
- e. Assists in making manpower assignments by ensuring that all systems of the ship are considered.
- f. Aids ship's force in "buttoning up" all systems for post-repair testing.
- g. Aids in alteration planning and analysis by showing possible interfaces in terms of various ship systems.

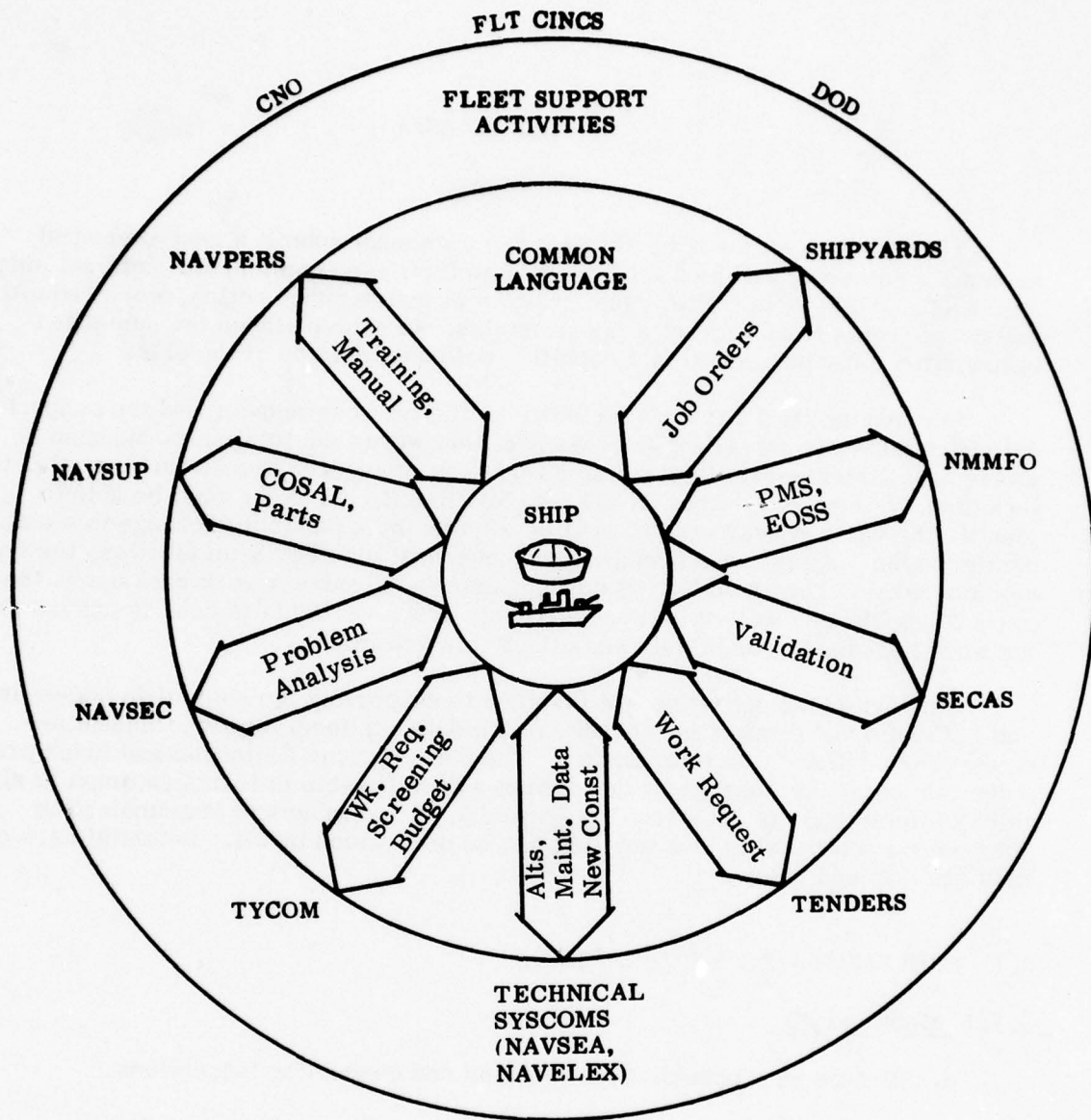

Figure 5. Uses of Ship Systems Definition and Index

- h. Aids in standardizing shipboard validation procedures.
- i. Provides a means of identifying deficiencies in shipboard documentation such as the Coordinated Shipboard Allowance List (COSAL), Planned Maintenance System (PMS), etc.
- j. Provides a capability for reducing duplication in validation programs.
- k. Assists in identifying Equipment Identification Codes needed as inputs to the Current Ship's Maintenance Project (CSMP) and Maintenance Data Collection System (MDCS).
- l. Provides a standard language for maintenance documentation.
- m. Provides a common set of system descriptions for the development of maintenance instructions (PMS) and operating instructions (Equipment Operational Sequencing System, EOSS).

### 3.1.2 Operation

- a. Serves as a checklist for determining the completeness of EOSS coverage.
- b. Provides a means of identifying the interrelationship between operating systems.
- c. Identifies the boundaries and checkpoints for system testing.
- d. Provides a means of determining test equipment and support requirements.

### 3.1.3 Training

- a. Provides a disciplined method for displaying a ship's configuration, thereby identifying training requirements from the equipment through the system level.
- b. Provides the primary aid in training shipboard operation/maintenance personnel in ship systems and system interfaces.

## 3.2 SSDI SUPPORT TO OTHER NAVAL ACTIVITIES

### 3.2.1 PERAs/Shipyards/Industrial Activities

- a. Defines ship systems for alteration and repair planning.
- b. Provides a standard language for:
  - Specification preparation
  - Cost estimating and progressing

- Drawing numbering
  - Material identification and ordering
  - Pre-Overhaul Test and Inspection (POT&I) planning and organization
  - Management information systems
- c. Assists in determining priorities of work by displaying the affected equipment in relation to its system.

**3.2.2 Ship Equipment Configuration Accounting System (SECAS)**

- a. Provides a standard structure for total shipboard validation.
- b. Provides information for determining the desired level of validation.

**3.2.3 Technical Systems Commands (NAVSEA, NAVELEX)**

- a. Aids in determining the SWBS identification of alterations for inclusion in shipalt records and subsequently in other Navy data bases.
- b. Identifies ship systems such that the impact of alterations can be determined and decisions made concerning recommended priorities for inclusion in the Fleet Modernization Program (FMP).
- c. Provides a means for ensuring that standard failure-data correlation and analysis is performed to the desired level.
- d. Serves as a baseline for the development of a complete ship test program.

**3.2.4 Type Commanders (TYCOMs)**

- a. Aids in determining work priorities by displaying the affected equipment in relation to its system.
- b. Identifies the system such that the impact of alterations can be determined and decisions made concerning recommended priorities for inclusion in the FMP.
- c. Enables the TYCOM to properly identify and budget the system for repairs.

**3.2.5 Naval Ships Engineering Center (NAVSEC)**

- a. Provides a vehicle for ensuring that standard failure-data correlation and analysis is performed to the desired level.
- b. Defines the systems for design consideration and subsequent corrective measures such as the Detection, Action, Response Technique (DART) program.

- c. Provides detailed information for determining the required level of repair parts support requirements.

3.2.6 Fleet Support Activities

- a. Identifies shipboard systems as an aid in determining personnel and material requirements in response to solving specific ship problems.
- b. Serves as a tool for establishing required support capabilities (people and equipment).

#### 4. GENERAL INFORMATION, FF-1052 CLASS

The data given in this section are generally applicable to the FF-1052 class. For individual ships of this class, consult the appropriate Ship's Information Book.

##### 4.1 BASIS OF HULL MEASUREMENTS

The designers waterline (D. W. L.) is the waterline corresponding to the normal displacement and draft. This waterline is 14' 9" above and parallel to the molded base line, and is the draft datum line for showing heights of superstructure, rigging, etc., as authorized by NAVSEA. This datum line is measured from the bottom of the keel plate amidships, which is 1/4" below the molded base line.

The forward perpendicular (F. P.) is a vertical passing through the point where the designer's waterline and the forward side of the ship's stern intersect. The after perpendicular (A. P.) is a vertical passing through the point where the designer's waterline and the molded line of the ship's stern intersect.

##### 4.2 GENERAL DIMENSIONS AND CHARACTERISTICS

Length, between perpendiculars	415' - 0"
Length, overall	438' - 0"
Breadth, extreme	46' - 7 1/4"
Draft above bottom of keel amidships (D. W. L.)	14' - 9 7/8"
Draft above lowest projection below keel (D. W. L.)	24' - 8 1/4"
Displacement to D. W. L. (salt water)	3,945 tons

##### 4.3 HEIGHTS ABOVE D. W. L.

(D. W. L. 14' - 9" above molded base line)

Quadmast, including antenna No. 4-2	104' - 2 1/2"
C. L. of homing beacon	107' - 6 1/8"
C. L. of forward anchor light	44' - 0"
C. L. of masthead light	56' - 11 1/4"
C. L. of towing lights	
Upper	62' - 11 1/4"
Lower	50' - 11 1/4"
C. L. of sidelight (P/S)	33' - 0 3/4"
C. L. of blinker light (P/S)	72' - 7 1/2"
C. L. of range light	92' - 10"
C. L. of speed and aircraft warning lights (P/S)	118' - 1 5/8"
C. L. of ASW light	98' - 11 1/2"

C.L. of man overboard and breakdown lights (2)  
and ships task lights (3)

Upper	118' - 7 3/8"
Middle	112' - 1 3/8"
Lower	105' - 7 3/8"
C.L. of aft anchor light	28' - 9"
C.L. of white stern light	19' - 9 7/16"
C.L. of blue stern light	18' - 5 7/16"
C.L. of wake light (P)	17' - 3' 5/16"
C.W.P. of rotating antenna No. 5-1	101' - 11 1/2"
C.W.P. of rotating antenna No. 5-2	81' - 4 1/2"
Underside of platform on quadmast	92' - 1 1/2"
06 level at top of billboard	67' - 1 1/2"
05 level at top of mack	58' - 1 1/2"
04 level in uptake space	49' - 1 1/2"
03 level at C.L. - aft FR 45	42' - 6 1/8"
03 level at C.L. - FR 54 (gun director platform)	44' - 11 1/2"
03 level in uptake space	40' - 1 1/2"
C.I.C. high hat	37' - 7 1/8"
02 level at C.L. - FR 45 1/2 (pilot house)	34' - 6 1/8"
02 level - FR 54 to 6" aft FR 69 (otbd C.I.C. high hat)	36' - 5 1/8"
02 level at C.L. - 6" aft FR 69	31' - 6 1/2"
02 level at C.L. - FR 93	30' - 9 1/2"
02 level at C.L. - FR 101 to FR 110	32' - 6 1/8"
02 level at C.L. - FR 110 (top of helo hangar)	35' - 10 1/2"
01 level at C.L. - FR 45 1/2 to FR 54	26' - 6 1/8"
01 level at C.L. - FR 54	24' - 6 1/8"
01 level at C.L. - FR 147	23' - 5 1/4"

4.4 SMALL BOATS

<u>No.</u>	<u>Name</u>	<u>Each</u>	<u>Total</u>
16	CO <sub>2</sub> Lifeboats	15	240
1	26' - 0" Personnel Boat	16	16
1	26' - 0" Motor Whaleboat	22	22
TOTAL			278

4.5 BERTHING ACCOMMODATIONS

	<u>Berths</u>		<u>Lockers</u>
Officers	17	Type A	15
CPO	15	Type B	33
Crew	225	Peacoat	11
		CPO (Blue Uniform)	1
		CPO (Overcoat)	2

#### 4.6 CAPACITY OF BOOMS AND CRANES

Boat Boom	3900 lb
Bathythermograph Boom	400 lb
ASROC and Torpedo Handling Boom	4000 lb
Mk 37 and EX 10 Torpedo Trolley Hoist - No. 2	4000 lb
Torpedo Magazine Crane - No. 1	1000 lb
ASROC Handling System	1500 lb

#### 4.7 FRAME SPACING

Frames are numbered from 0 at the forward perpendicular to 166 at the after perpendicular. Frame spacing is 30" throughout.

Ships of the FF-1052 class are longitudinal framed vessels. Transverse framing does not exist at each frame numbered location. Transverse webs are spaced approximately every three frames between Frame 18 and the stern, and every two frames forward of Frame 18.

Part frames in the forward overhang are designated as "A", "B", "C", "D", "E", "F", and "G".

#### 4.8 TANK CAPACITIES AT FULL LOAD CONDITIONS FOR FF-1052 - 1077

<u>Tank</u>	<u>Gallons</u>	<u>Tons</u>
a. <u>Potable Water</u>		
5-107-1-W	1,775	6.59
5-107-2-W	1,773	6.59
5-114-1-W	3,277	12.17
5-114-2-W	3,277	12.17
Total	10,104	37.52
b. <u>Reserve Feed Water</u>		
3-92-1-W	2,351	8.73
3-92-2-W	2,351	8.73
5-107-0-W	3,280	12.18
5-110-0-W	3,622	13.45
Total	11,604	43.09
c. <u>Lube Oil</u>		
5-101-1-F	1,078	3.70
5-104-3-F	1,034	3.55
Total	2,112	7.25

<u>Tank</u>	<u>Gallons</u>	<u>Tons</u>
d. <u>JP-5</u>		
5-125-0-J	12,797	38.79
5-137-0-J	13,661	41.41
Service Tank	1,000	3.03
Total	27,458	83.23
e. <u>Fuel Oil</u>		
(1) <u>Storage</u>		
5-29-1-E	4,871	17.15
5-29-2-F	4,871	17.15
5-41-1-F	15,856	55.83
5-41-2-F	15,856	55.83
5-48-1-F	15,819	55.70
5-48-2-F	15,819	55.70
5-54-1-F	20,888	73.55
5-54-2-F	20,888	73.55
5-61-1-F	10,724	37.76
5-61-2-F	10,724	37.76
5-121-1-F	6,558	23.09
5-121-4-F	5,430	19.12
5-126-1-F	6,168	21.72
5-126-2-F	6,168	21.72
5-132-1-F	7,231	25.46
5-132-2-F	7,231	25.46
5-150-0-F	8,219	28.94
Total	183,321	645.49
(2) <u>Service</u>		
4-76-0-F	12,320	43.38
5-61-0-F	18,503	65.15
Total	30,823	108.53
Total Fuel Oil	214,144	754.02

## 5. SSDI FOR FF-1052 CLASS SHIPS

### 5.1 SSDI INDEX

The SSDI for FF-1052 class ships is presented on the following pages. The diagrams appear in the following order.

Index Diagrams	Page
Overall	27
100 - Hull Structure	28
200 - Propulsion Plant	29
300 - Electric Plant	30
400 - Command and Surveillance	31
500 - Auxiliary Systems	32
600 - Outfit and Furnishings	33
700 - Armament	34
800 - Integration/Engineering	35
Legend of Symbols	37
System Diagrams	
100 - Hull Structure	41
200 - Propulsion Plant	55
300 - Electric Plant	97
400 - Command and Surveillance	115
500 - Auxiliary Systems	151
600 - Outfit and Furnishings	205
700 - Armament	233
800 - Integration/Engineering	245

The Legend of Symbols provides guidance to the ship system diagrams that accompany certain of the diagrams.

### 5.2 GENERAL COMMENTS

The following general comments apply to the FF-1052 class SSDI:

- a. In each WBS group, elements X01 through X09 are used for general requirements, and element X98 is used for operating liquids. These nonhardware elements are indicated by dashed blocks.
- b. To maintain continuity of having equipments/components at the fifth level, some element titles have been repeated at the fourth and fifth levels and appropriately numbered, e. g., element 115.

- c. The term "With System", or "W.S.", indicates that the item is coded with the system of which it is a part of or which it serves.
- d. EIC cross-references are entered only in blocks with a direct cross-reference, i.e., same system, subsystem, equipment as a SWBS classification.
- e. Work center assignments apply only to USS WHIPPLE (FF-1062). Use of the SSDI for other ships of the class will require verification of applicable work centers.
- f. Elements where no specific equipments could be identified at this time (e.g., future installations) are shown by double-dashed blocks.

### 5.3 SWBS CLASSIFICATIONS NOT INCLUDED

The WBS groups, subgroups, and elements listed in Table 1 were determined to be not applicable to the FF-1052 class for purposes of this Ship System Definition and Index.

**TABLE 1. NONAPPLICABLE WBS ITEMS FOR FF-1052 CLASS SSDI**  
(Sheet 1 of 4)

Group	Subgroup	Element	Title	
<b>GROUP 0: GENERAL GUIDANCE AND ADMINISTRATION</b>				
<b>000</b>	<b>All</b>	<b>All</b>	<b>General Guidance &amp; Administration</b>	
<b>GROUP 1: HULL STRUCTURE</b>				
<b>100</b>	<b>110</b>	112	Shell Plating, Submarine Nonpressure Hull	
		113	Inner Bottom	
		118	Longitudinal and Transverse Submarine Nonpress. Hull Framing	
	<b>120</b>	124	Bulkheads in Torpedo Protection System	
		125	Submarine Hard Tanks	
		126	Submarine Soft Tanks	
	<b>130</b>	133	3rd Deck	
		134	4th Deck	
		135	5th Deck	
	<b>140</b>	143	3rd Platform	
		144	4th Platform	
		145	5th Platform	
	<b>150</b>	157	6th Deckhouse Level	
		158	7th Deckhouse Level	
		159	8th Deckhouse Level and Above	
	<b>160</b>	164	Ballistic Plating	
		166	Sponsons	
	<b>190</b>	<b>195</b>		Erections of Subsections (Progress Report Only)
	<b>GROUP 2: PROPULSION PLANT</b>			
<b>200</b>	<b>210</b>	<b>All</b>	Energy Generating System (Nuclear)	
	<b>220</b>	222	Gas Generators	
		223	Main Propulsion Batteries	
		224	Main Propulsion Fuel Cells	
	<b>230</b>	232	Propulsion Steam Engines	
		233	Propulsion Internal Combustion Engines	
		234	Propulsion Gas Turbines	
		235	Electric Propulsion	
		236	Self-Contained Propulsion Systems	
		237	Auxiliary Propulsion Devices	
		238	Secondary Propulsion (Submarines)	
	239	Emergency Propulsion (Submarines)		

TABLE 1. (Sheet 2 of 4)

Group	Subgroup	Element	Title
GROUP 2: PROPULSION PLANT (Continued)			
200	240	246 247	Propulsor Shrouds and Ducts Water Jet Propulsors
	260	263	Shaft Lube Oil System (Submarines)
GROUP 3: ELECTRIC PLANT			
300	310	312	Emergency Generators
	320	322	Emergency Power Cable System
GROUP 4: COMMAND AND SURVEILLANCE			
400	410	412	Data Processing Group
		413	Digital Data Switchboards
		414	Interface Equipment
		415	Digital Data Communications
		416	Command and Control Testing
		417	Command and Control Analog Switchboards
	420	425	Periscopes
		427	Inertial Navigation Systems
		428	Navigation Control Monitoring
	440	444	Telemetry Systems
	450	453	Air Search Radar (3D)
		454	Aircraft Control Approach Radar
		459	Space Vehicle Electronic Tracking
	460	461	Active Sonar
464		Classification Sonar	
470	476	Mine Countermeasures	
490	492	Flight Control and Instrument Landing Systems	
	493	Non-Combat Data Processing Systems	
	494	Meteorological Systems	
	495	Integrated Operational Intelligence Systems	
GROUP 5: AUXILIARY SYSTEMS			
500	510	515 517	Air Revitalization Systems (Submarines) Auxiliary Boilers and Other Heat Sources
		540	543 544

TABLE 1. (Sheet 3 of 4)

Group	Subgroup	Element	Title
GROUP 5: AUXILIARY SYSTEMS (Continued)			
500	550	552	Compressed Gases
		553	O <sub>2</sub> N <sub>2</sub> System
		554	LP Blow
		556	Hydraulic Fluid System
		557	Liquid Gases, Cargo
		558	Special Piping Systems
	560	563	Buoyancy and Hovering (Submarines)
		564	Trim System (Submarines)
		565	Trim and Heel (Roll Stabilization)
		567	Lift Systems
		568	Maneuvering Systems
	570	573	Cargo Handling
	580	585	Elevating and Retracting Gear
		586	Aircraft Recovery Support Systems
		587	Aircraft Launch Support Systems
		589	Miscellaneous Mechanical Handling Systems
	590	591	Scientific and Ocean Engineering Systems
		592	Swimmer and Diver Support and Protection Systems
		594	Submarine Rescue, Salvage and Survival Systems
		596	Handling System for Diver and Submersible Vehicles
		597	Salvage Support Systems
GROUP 6: OUTFIT AND FURNISHINGS			
600	630	639	Radiation Shielding
	650	653	Dental Spaces
	670	673	Cargo Stowage
GROUP 7: ARMAMENT			
700	720	724	Missile Hydraulics
		725	Missile Gas
		726	Missile Compensating
	730	All	Mines
	740	All	Depth Charges
750	754	Submarine Torpedo Ejection	

TABLE 1. (Sheet 4 of 4)

Group	Subgroup	Element	Title
<b>GROUP 7: ARMAMENT (Continued)</b>			
700	770	All	Cargo Munitions
	780	All	Aircraft Related Weapons
<b>GROUP 8: INTEGRATION/ENGINEERING (SHIPBUILDER RESPONSE)</b>			
800	820	All	Special Drawings for Nuclear Propulsion Systems
<b>GROUP 9: SHIP ASSEMBLY AND SUPPORT SERVICES</b>			
900	All	All	Ship Assembly and Support Services

SHIP SYSTEMS DEFINITION AND INDEX  
FOR FF-1052 CLASS SHIPS

Ship  
FF-1052  
Class

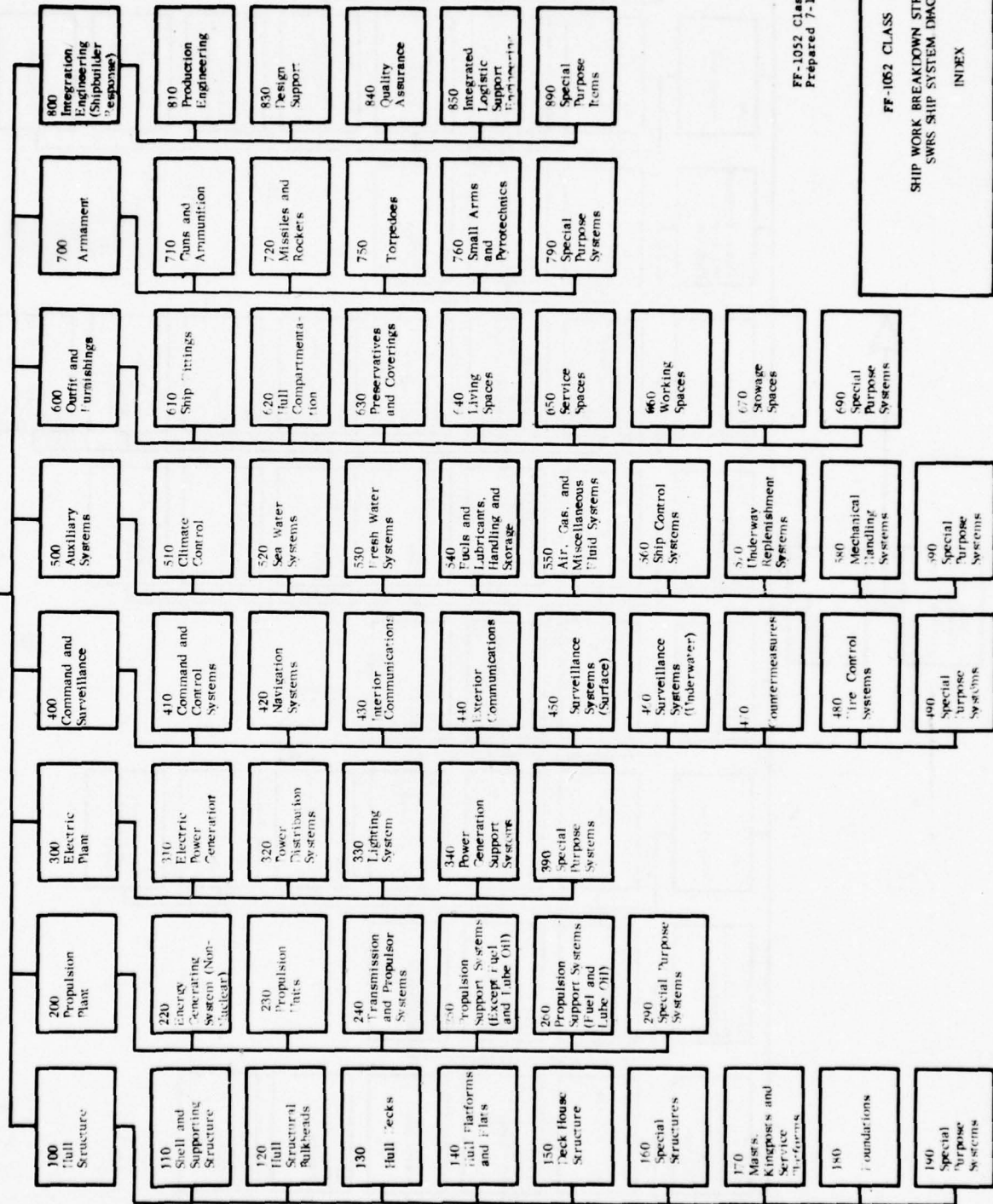

FF-1052 Class  
Prepared 7-19-76

FF-1052 CLASS  
SHIP WORK BREAKDOWN STRUCTURE  
SWRS SHIP SYSTEM DIAGRAM  
INDEX

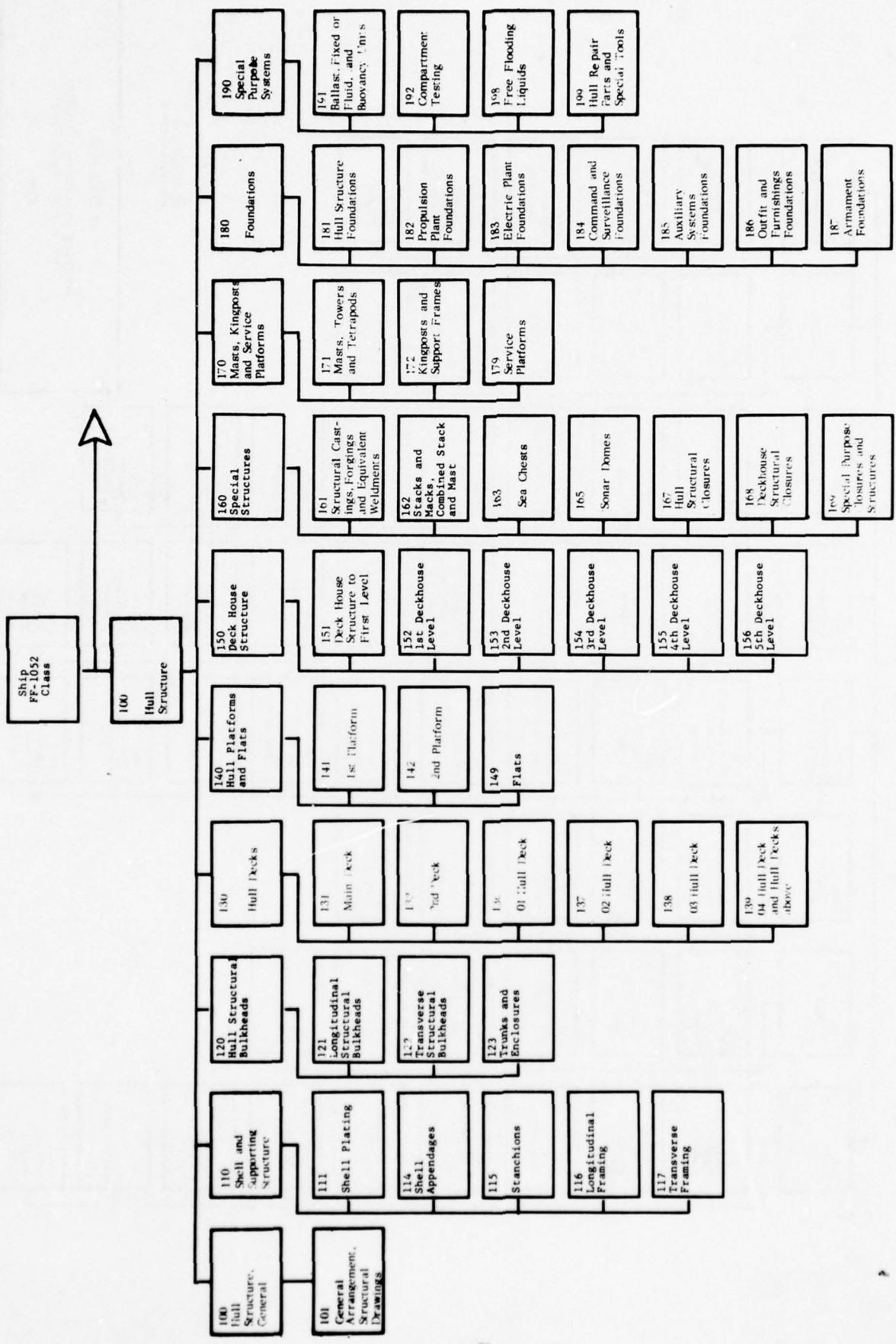

FF-1052 Class  
Prepared 7-19-76

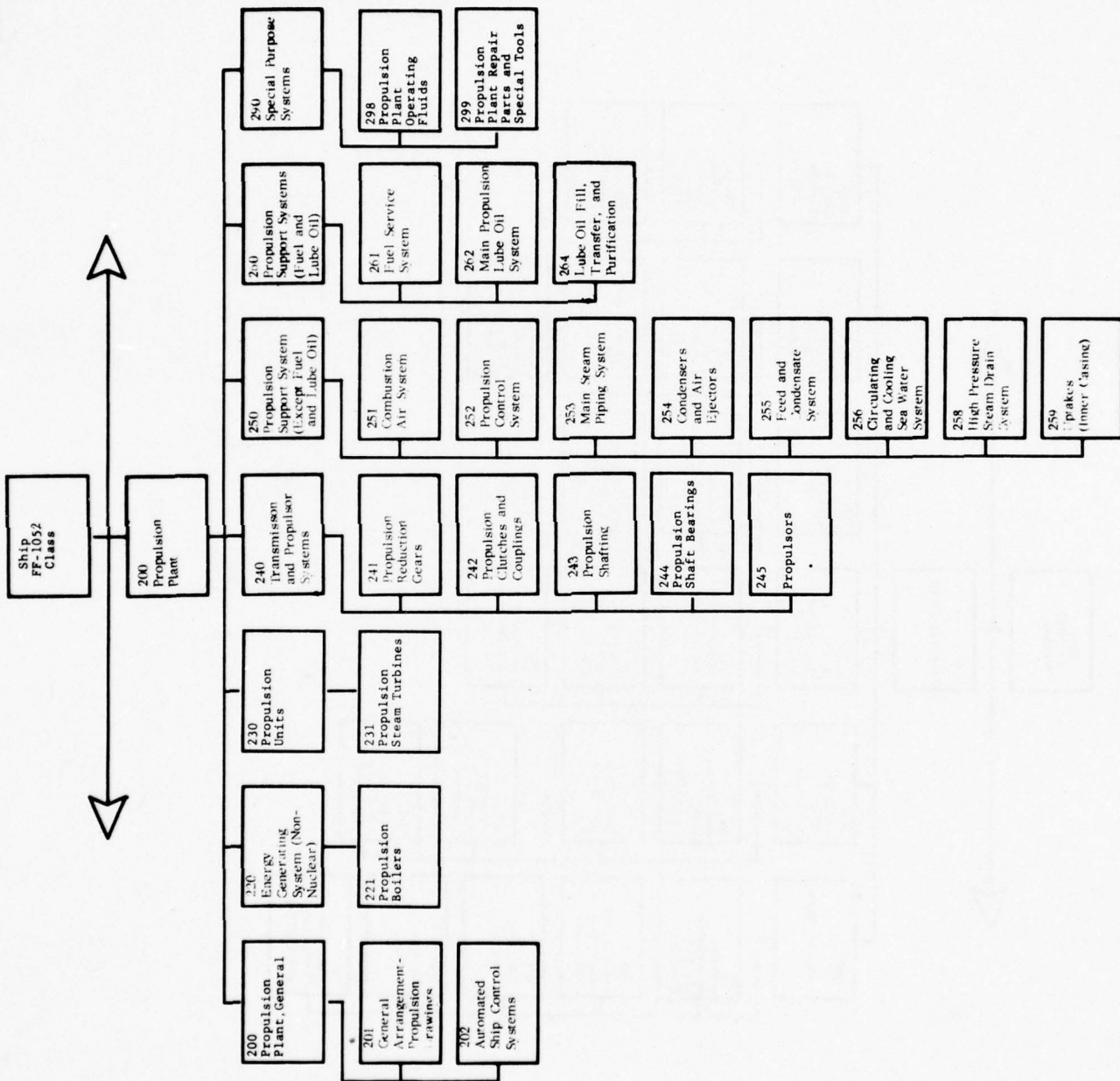

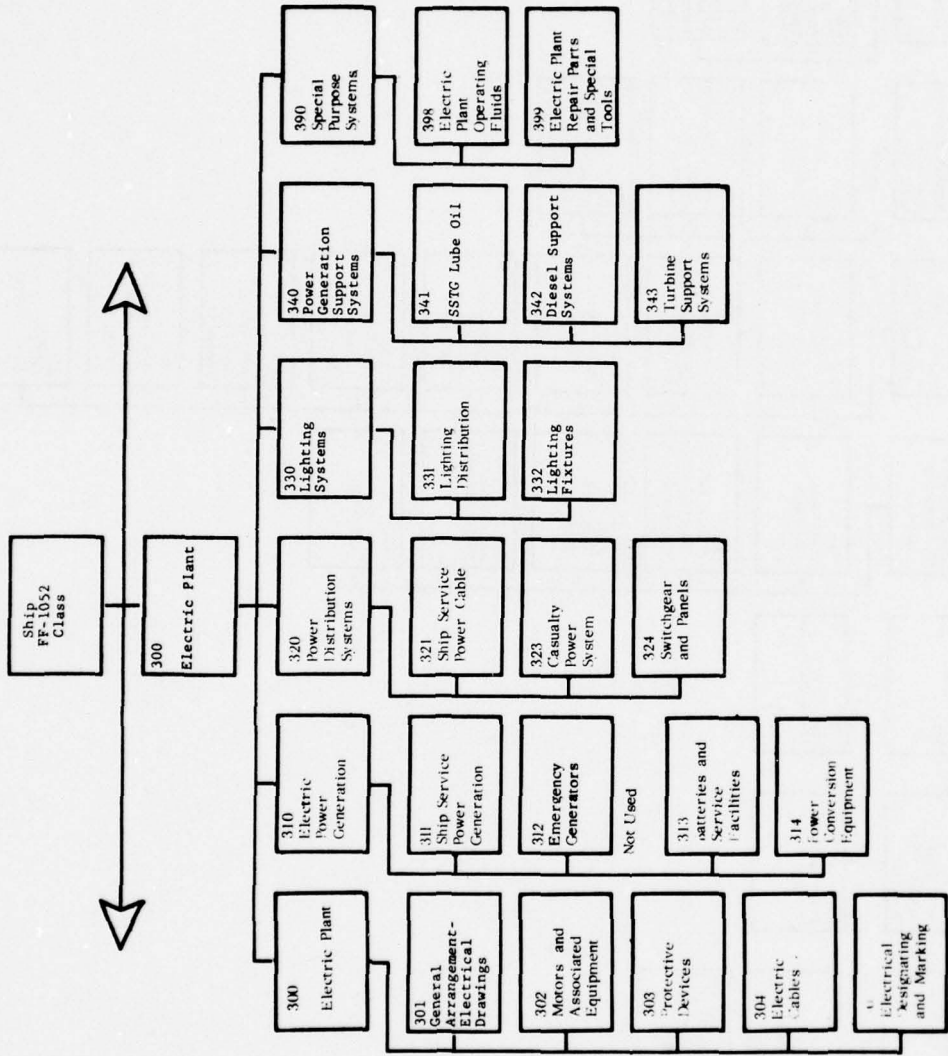

Ship  
FF-1052  
Class

400  
Command  
and  
Surveillance

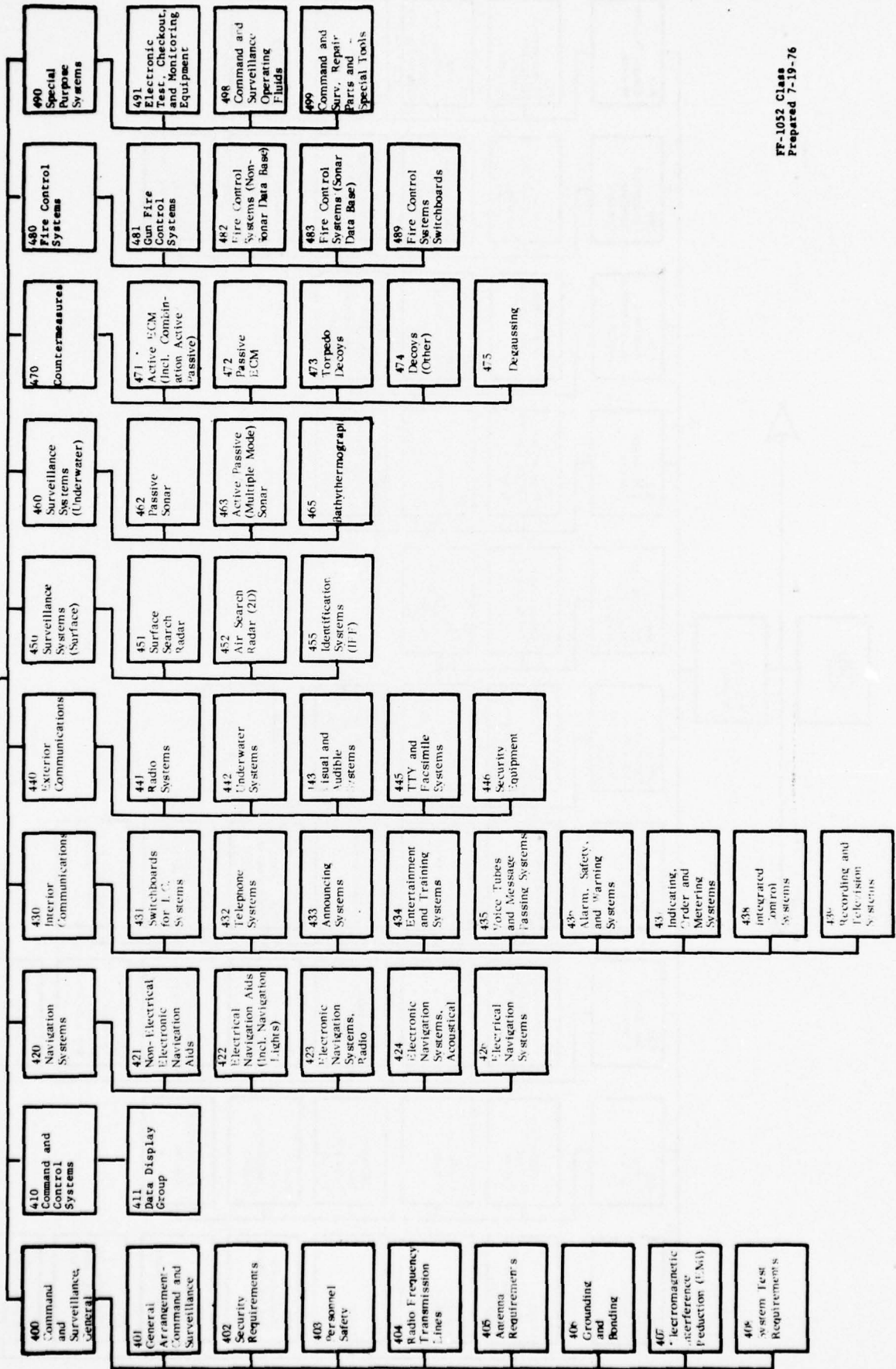

FF-1052 Class  
Prepared 7-19-76

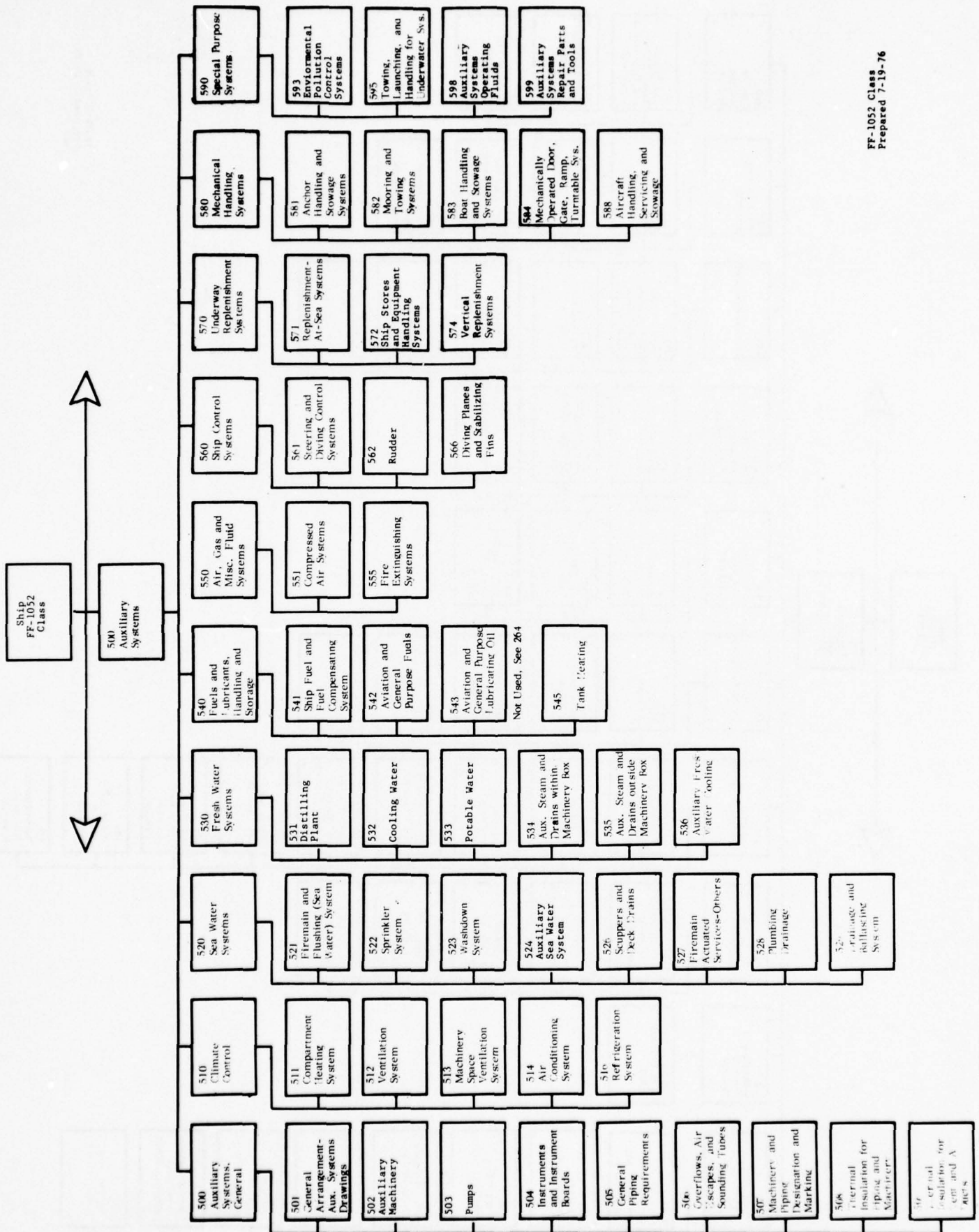

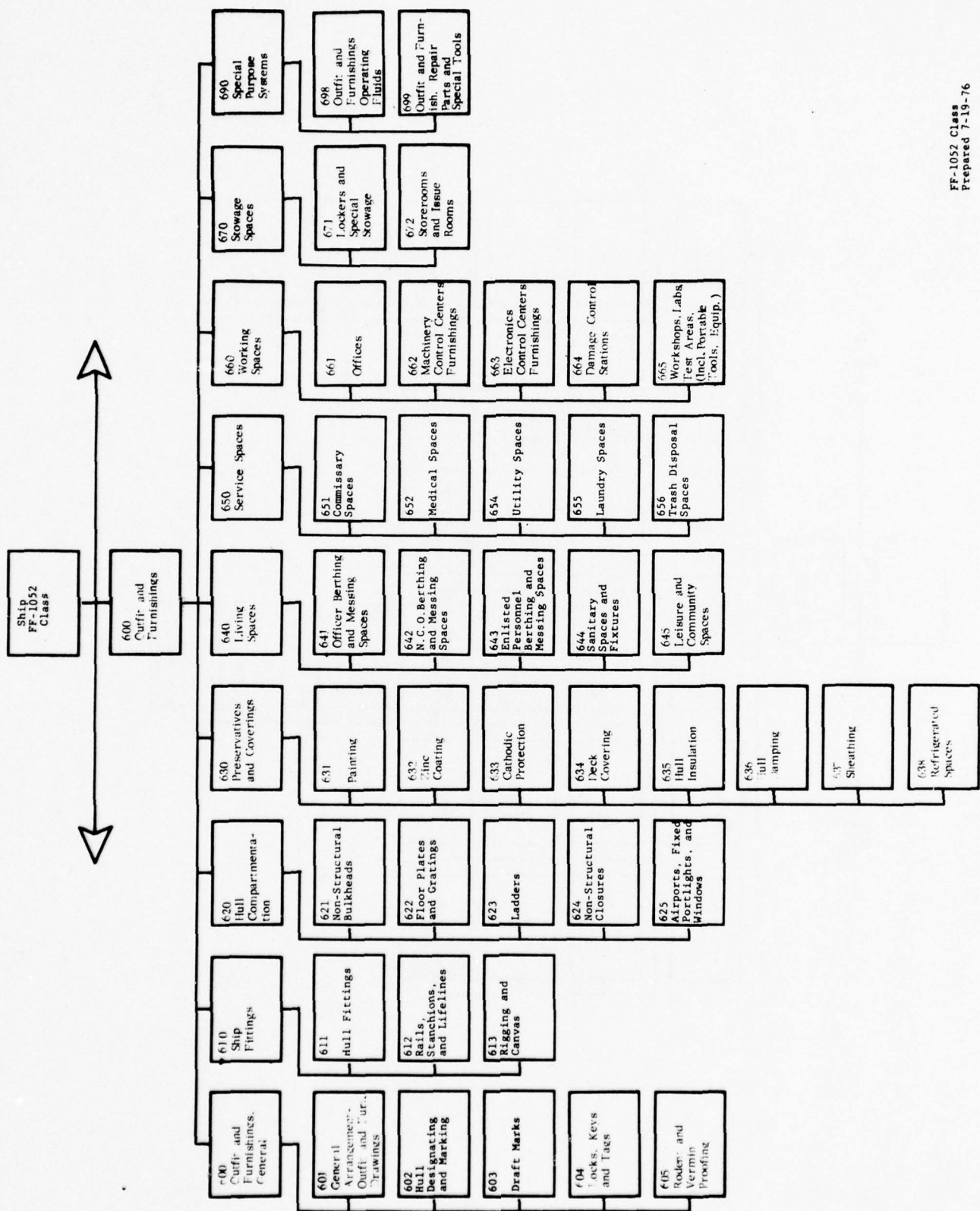



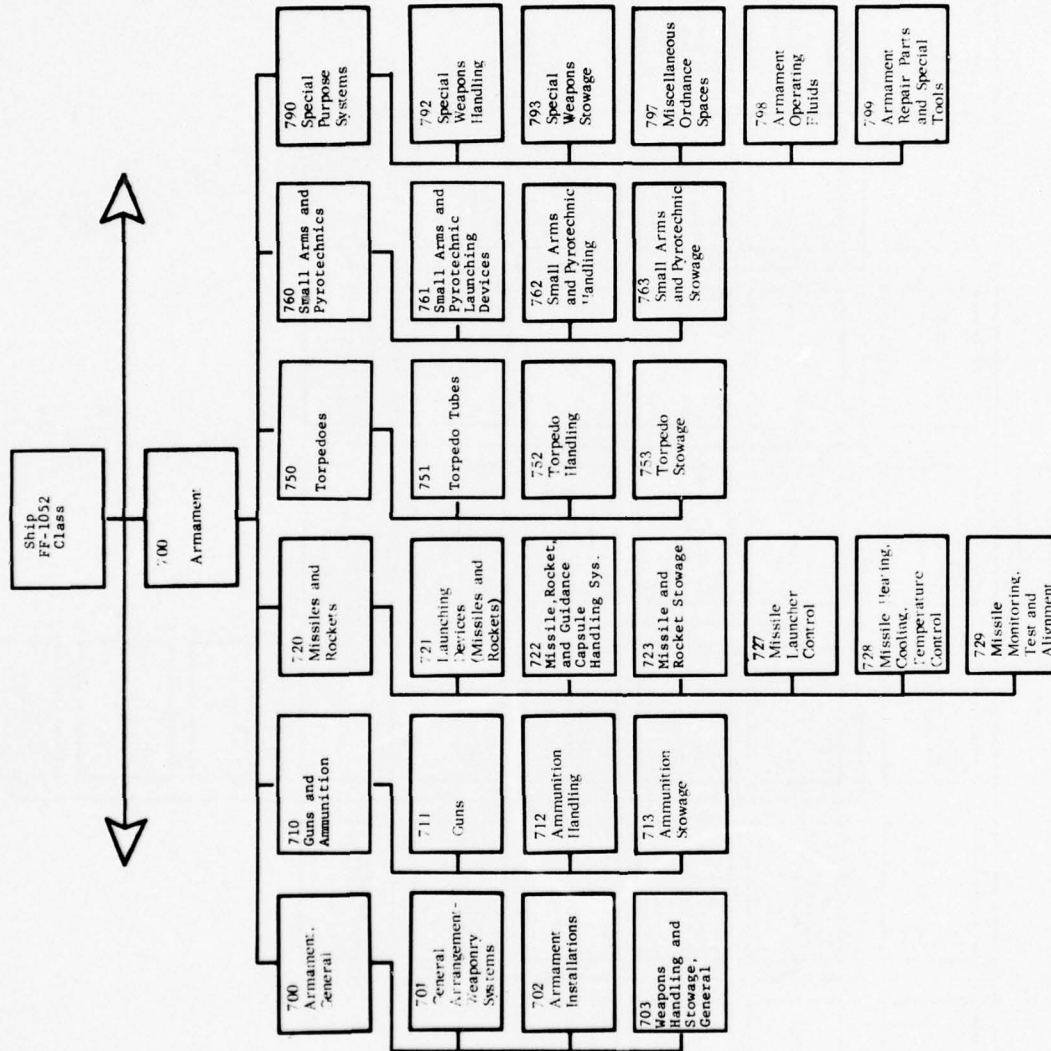





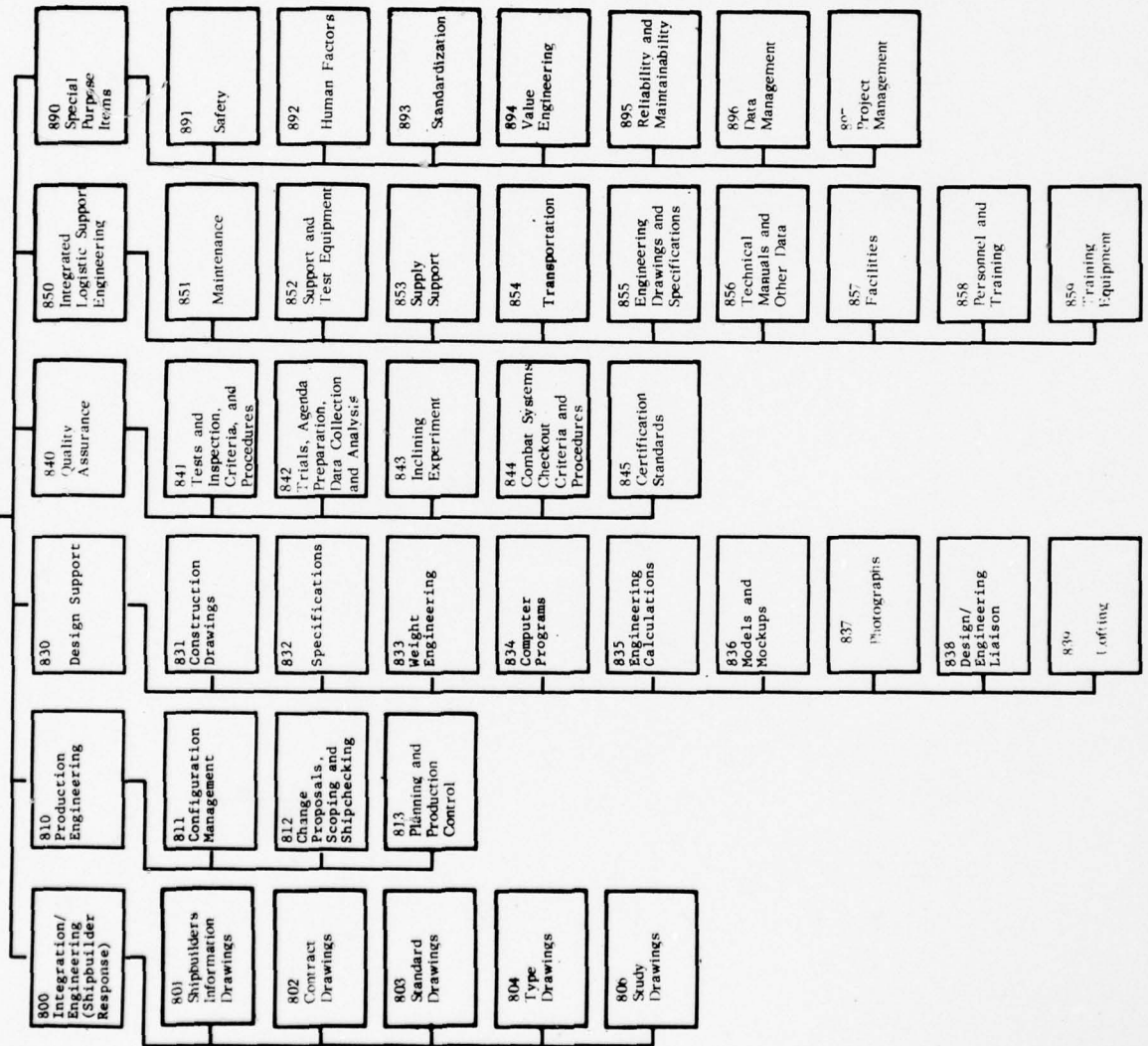



















FF-1052 Class  
Prepared 7-19-76



Ship  
FF-1052  
Class



























800  
Integration  
Engineering  
(Shipbuilder  
Response)































LEGEND OF SYMBOLS	
SYMBOL	DESCRIPTION
	GLOBE VALVE
	GLOBE VALVE, LOCKED OPEN
	GLOBE VALVE, LOCKED CLOSED
	GLOBE VALVE, MANUALLY OPERATED IN PLACE OR PNEUMATICALLY FROM MAIN DECK
	AIR MOTOR OPERATED VALVE
	GLOBE VALVE, WITH MANUAL GEAR OPERATED IN PLACE AND ADJACENT SPACE
	GLOBE VALVE, ANGLE
	GLOBE VALVE, REMOTE OPERATED
	GLOBE STOP CHECK VALVE
	GATE VALVE
	BUTTERFLY VALVE
	SWING CHECK VALVE
	LIFT CHECK VALVE
	NEEDLE VALVE
	STOP COCK PLUG OR CYLINDER VALVE 3 WAY, 2 PORT
	CONTROLLED VALVE, BOILER FEED
	PRESSURE REDUCING OR PRESSURE REGULATING INCREASED ACTUATING PRESSURE CLOSES
	PRESSURE REDUCING OR PRESSURE REGULATING DECREASED ACTUATING PRESSURE CLOSES
	PRESSURE REGULATING VALVE AIR PILOT OPERATED
	PUMP GOVERNOR
	THERMOSTATICALLY CONTROLLED VALVE
	DUMP VALVE
	PILOT VALVE
	FLOAT OPERATED VALVE
	ANGLE LIFT CHECK VALVE
	CONTROL VALVE
	HOSE CONNECTION AND GLOBE VALVE

NOTE: VALVES OTHER THAN THE GLOBE VALVE MAY USE THE MODIFIERS SHOWN. IN ADDITION COMBINATIONS OF VALVE MODIFIERS MAY BE USED.

## LEGEND OF SYMBOLS

SYMBOL	DESCRIPTION
	VENT
	BOILER DRUM SAFETY VALVE
	ANGLE RELIEF VALVE (ENCLOSED SPRING)
	COMBINED EXHAUST AND RELIEF VALVE
	PRESSURE GAUGE
	VACUUM - PRESSURE GAUGE
	DUPLEX PRESSURE GAUGE
	ABSOLUTE PRESSURE GAUGE
	DISTANT READING PRESSURE GAUGE
	DISTANT READING THERMOMETER
	SIGHT READING THERMOMETER
	THERMO ELEMENT
	METER, SIGHT FLOW
	PRESSURE BREAKDOWN ORIFICE
	OPEN FUNNEL
	SPECTACLE FLANGE
	DUPLEX STRAINER
	Y STRAINER
	STRAINER
	IMPULSE TRAP & STRAINER
	SALINITY CELL
	ORIFICE PLATE
	MOTOR CONTROLLER
	TEST TEE
	DESUPERHEATER
	MANIFOLD
	EDUCTOR

LEGEND OF SYMBOLS	
SYMBOL	DESCRIPTION
	PUSHBUTTON & INDICATOR LIGHT
	PUSHBUTTON
	EXPANSION JOINT
	GAGE GLASS
	DUPLEX (TWIN BASKET) MAGNETIC STRAINER
	THERMOCOUPLE CONNECTION OR THERMOSTAT
	THERMOMETER ANY ANGLE DIAL, BARE BULB TYPE DIRECT READING
	THERMOMETER DISTANT READING BARE BULB TYPE
	CONSTANT FLOW FITTING
	FUNNEL WITH SWING COVER
	CONCENTRIC REDUCER
	REDUCER
	HOSE ADAPTER
	SOUND ISOLATION FITTING
	FLEXIBLE HOSE
	FLOW MEASURING NOZZLE
	SHAFT TURBINE END, COUPLING OIL SPRAY
	ANGLE STOP VALVE
	BALL CHECK STOP VALVE
	PRESSURE VENT
	LOCK SHIELD VALVE, HIGH LIFT
	BOTTOM BLOWDOWN VALVE, HIGH LIFT
	TOP BLOWDOWN VALVE, HIGH LIFT
	AIR OPERATED VALVE SPRING CLOSING
	AUTOMATIC RECIRCULATING VALVE
	CROSS VALVE
	MOTOR PRESSURE SWITCH
	LIMIT SWITCHES

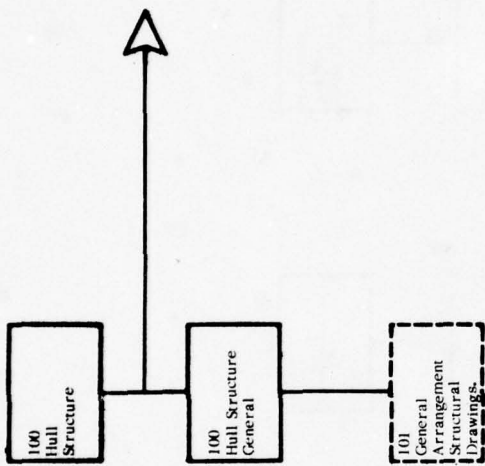

FF-1052 Class  
Prepared 7-19-76

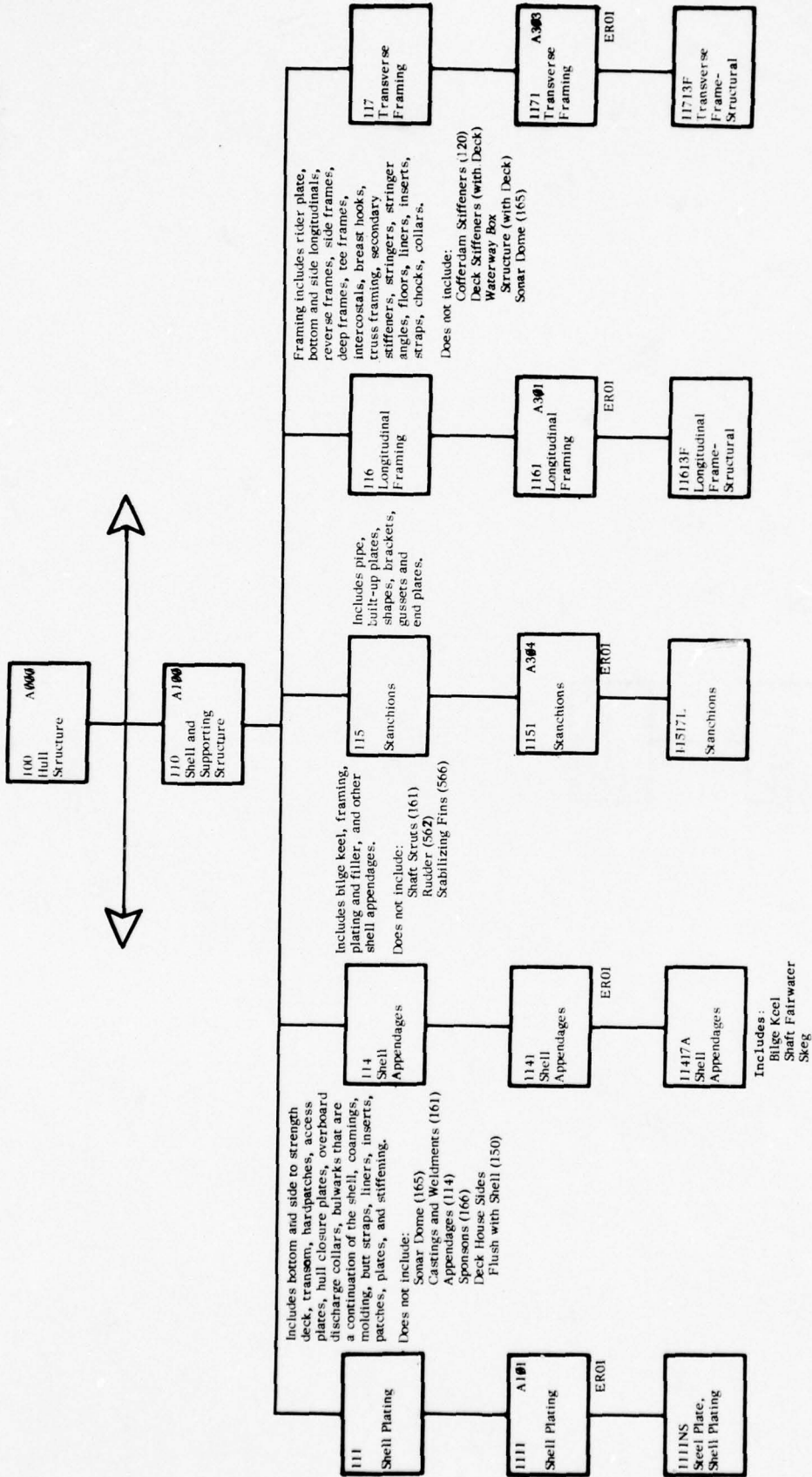

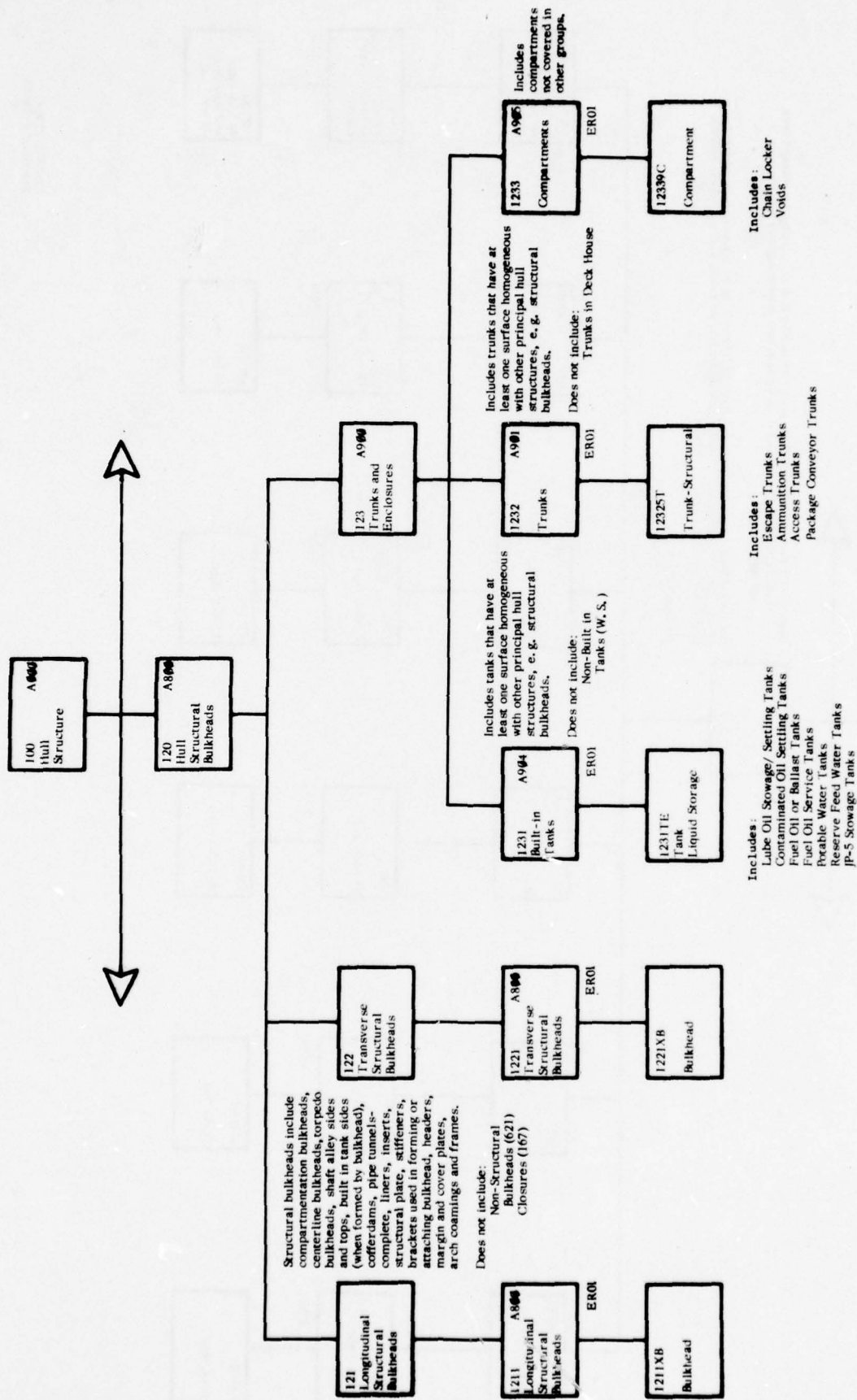

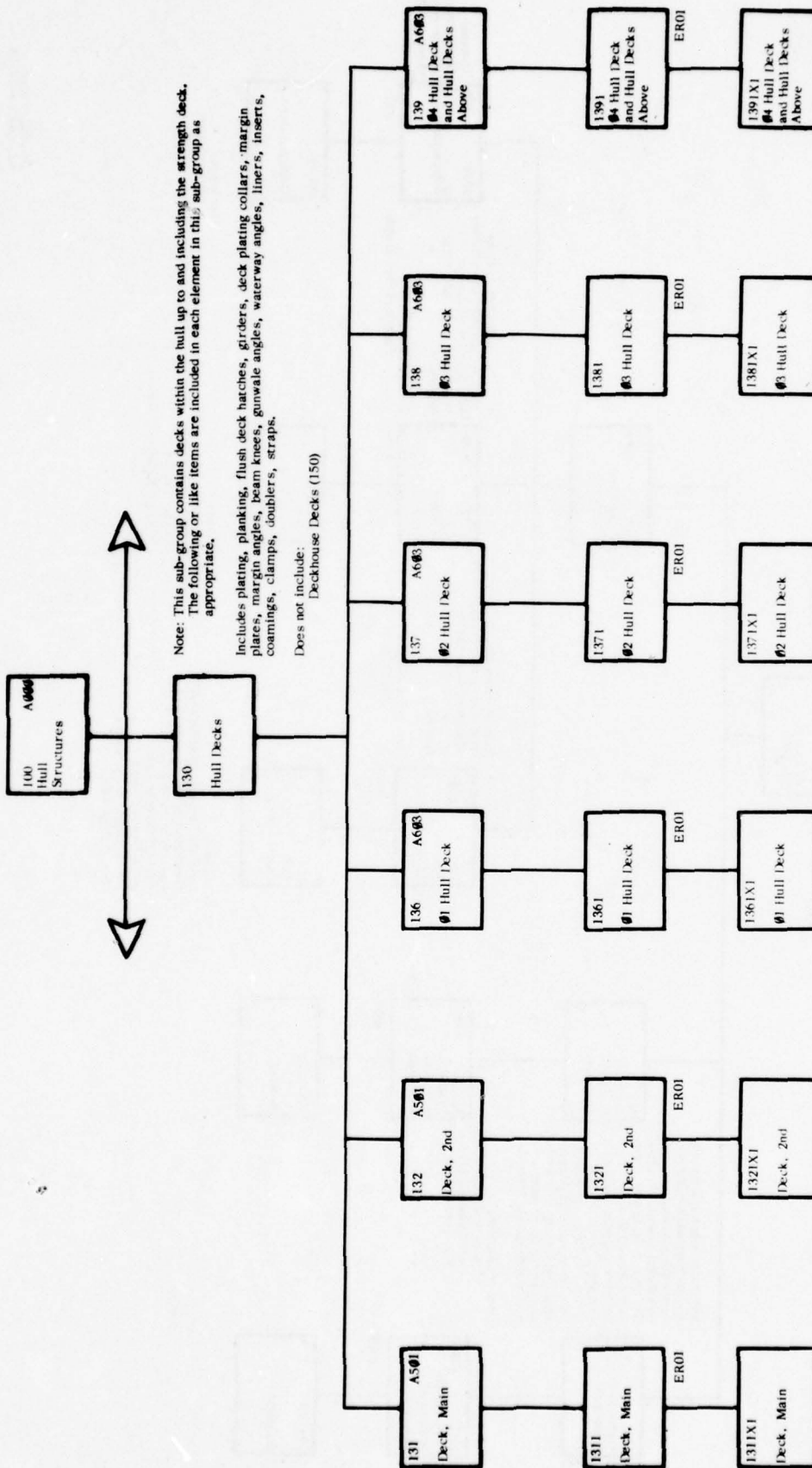

Note: This sub-group contains decks within the hull up to and including the strength deck. The following or like items are included in each element in this sub-group as appropriate.

Includes plating, planking, flush deck hatches, girders, deck plating collars, margin plates, margin angles, beam knees, gunwale angles, waterway angles, liners, inserts, coamings, clamps, doublers, straps.

Does not include:  
Deckhouse Decks (150)

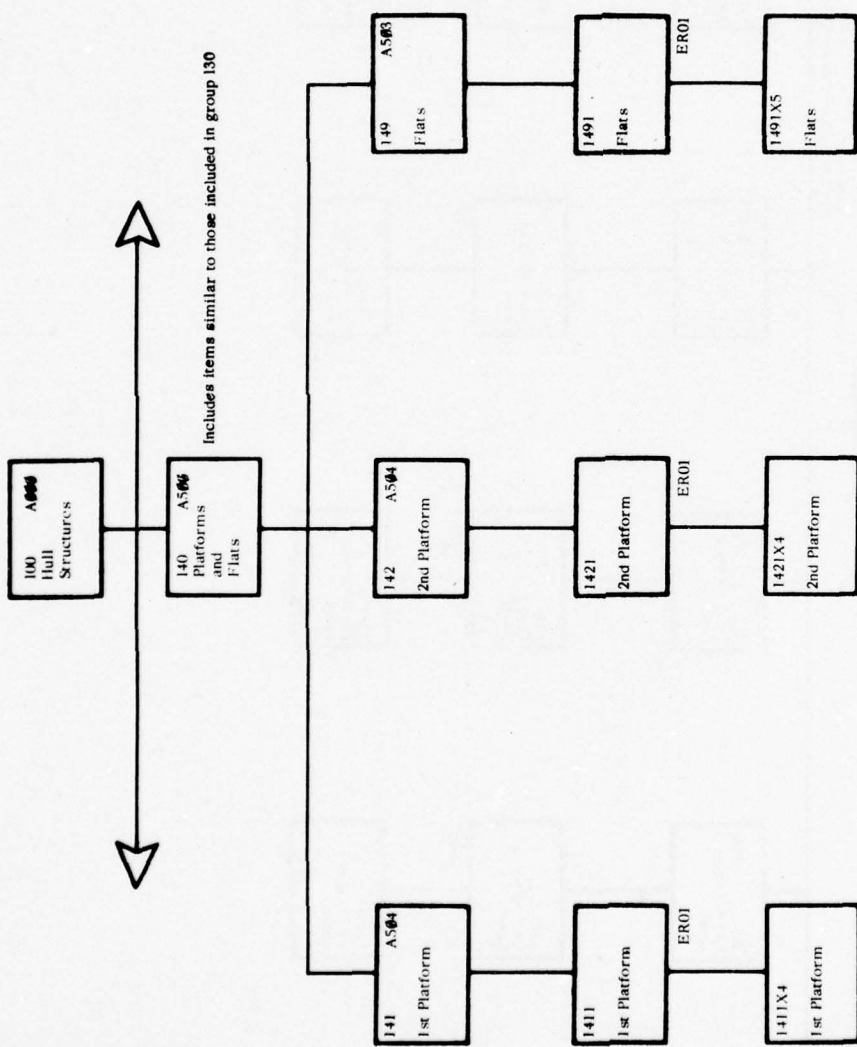

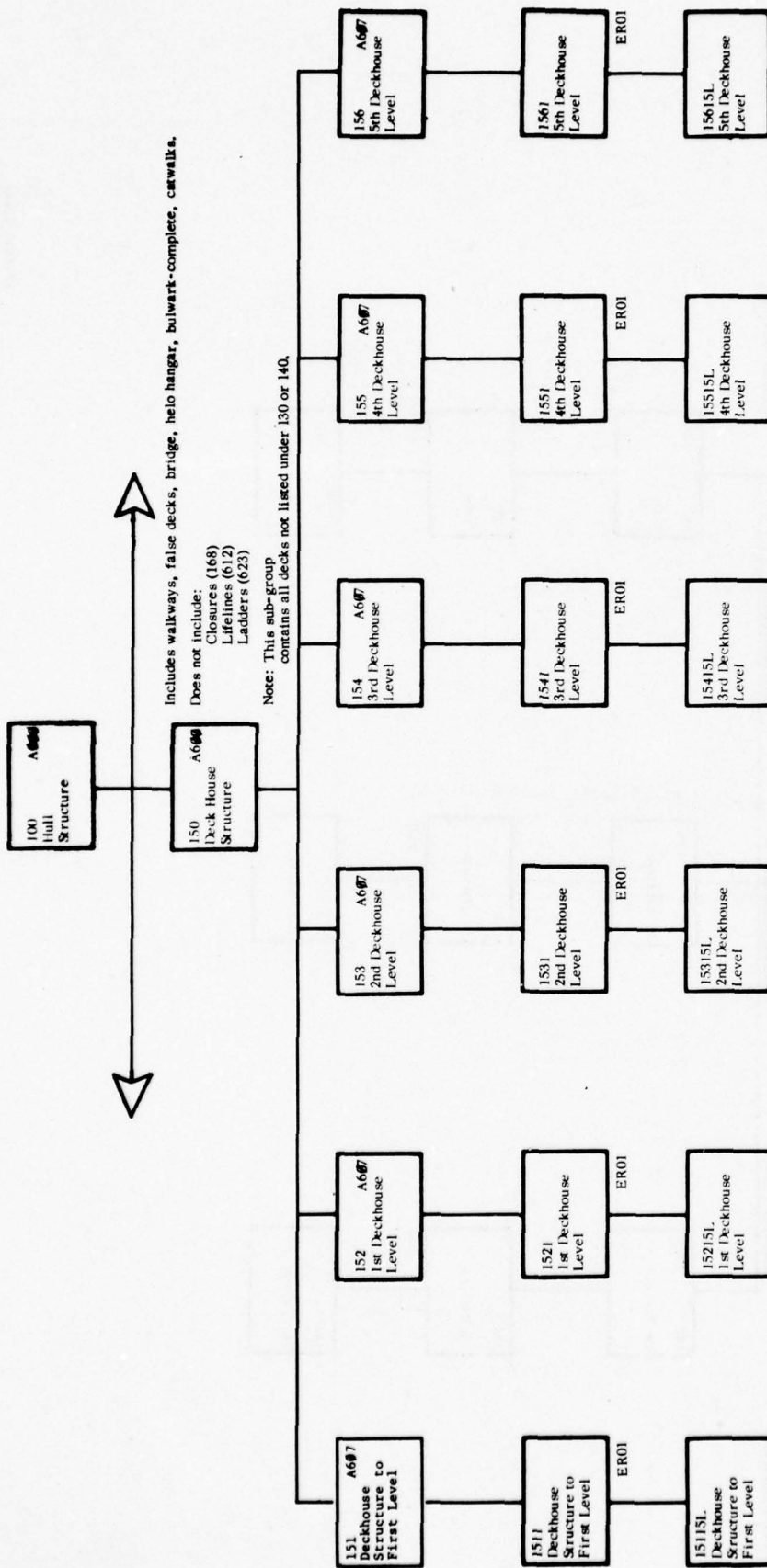

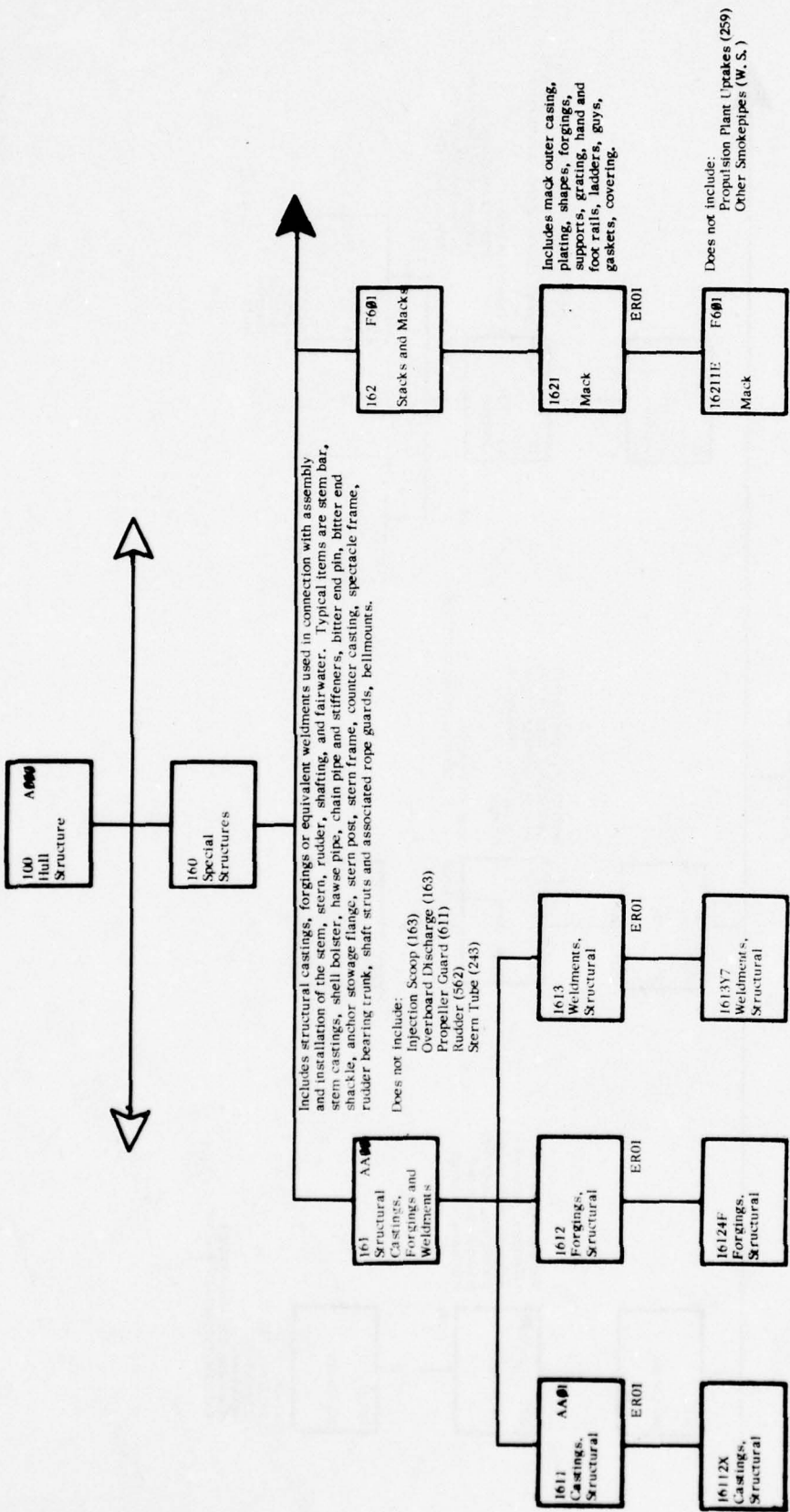

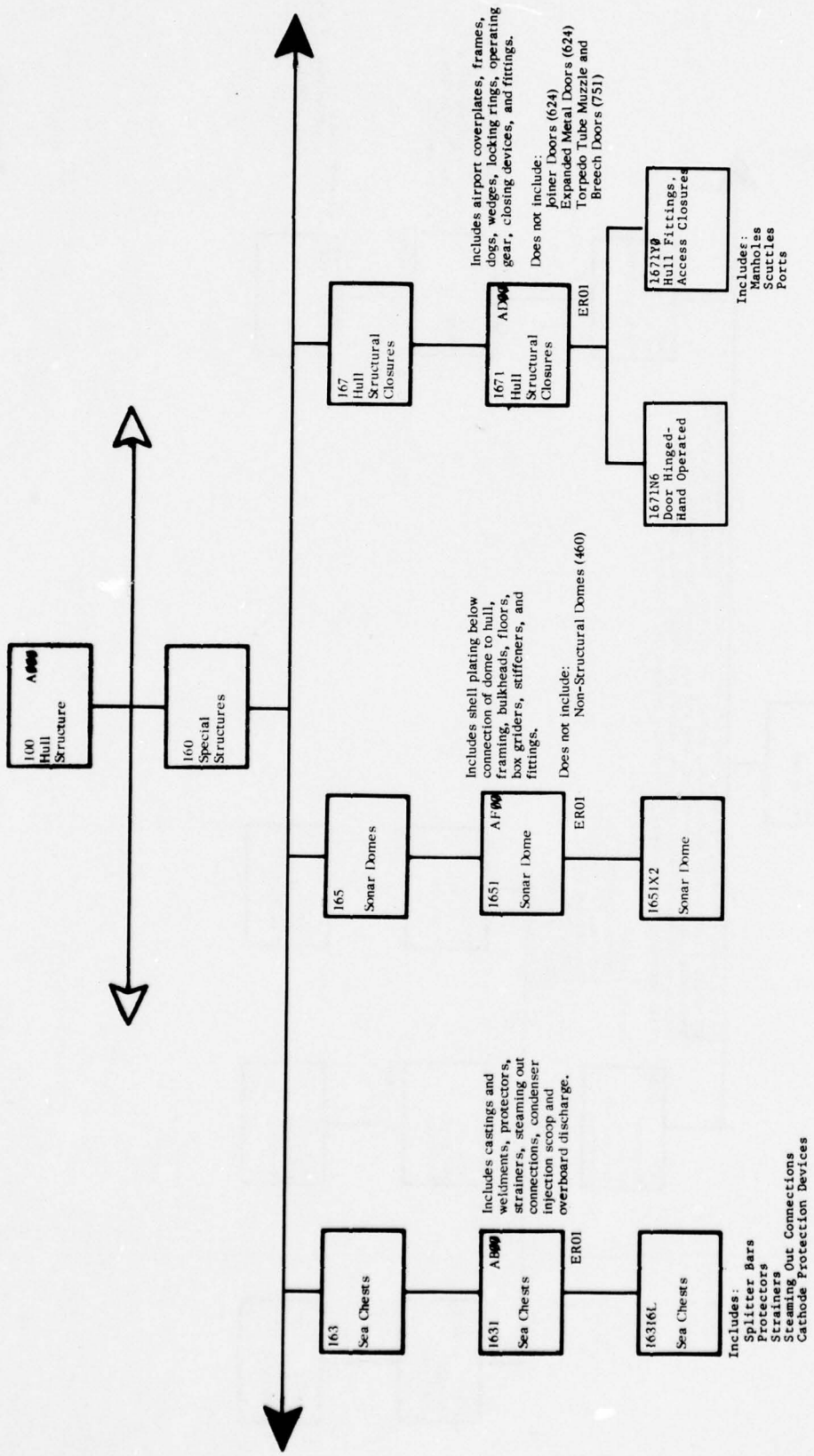

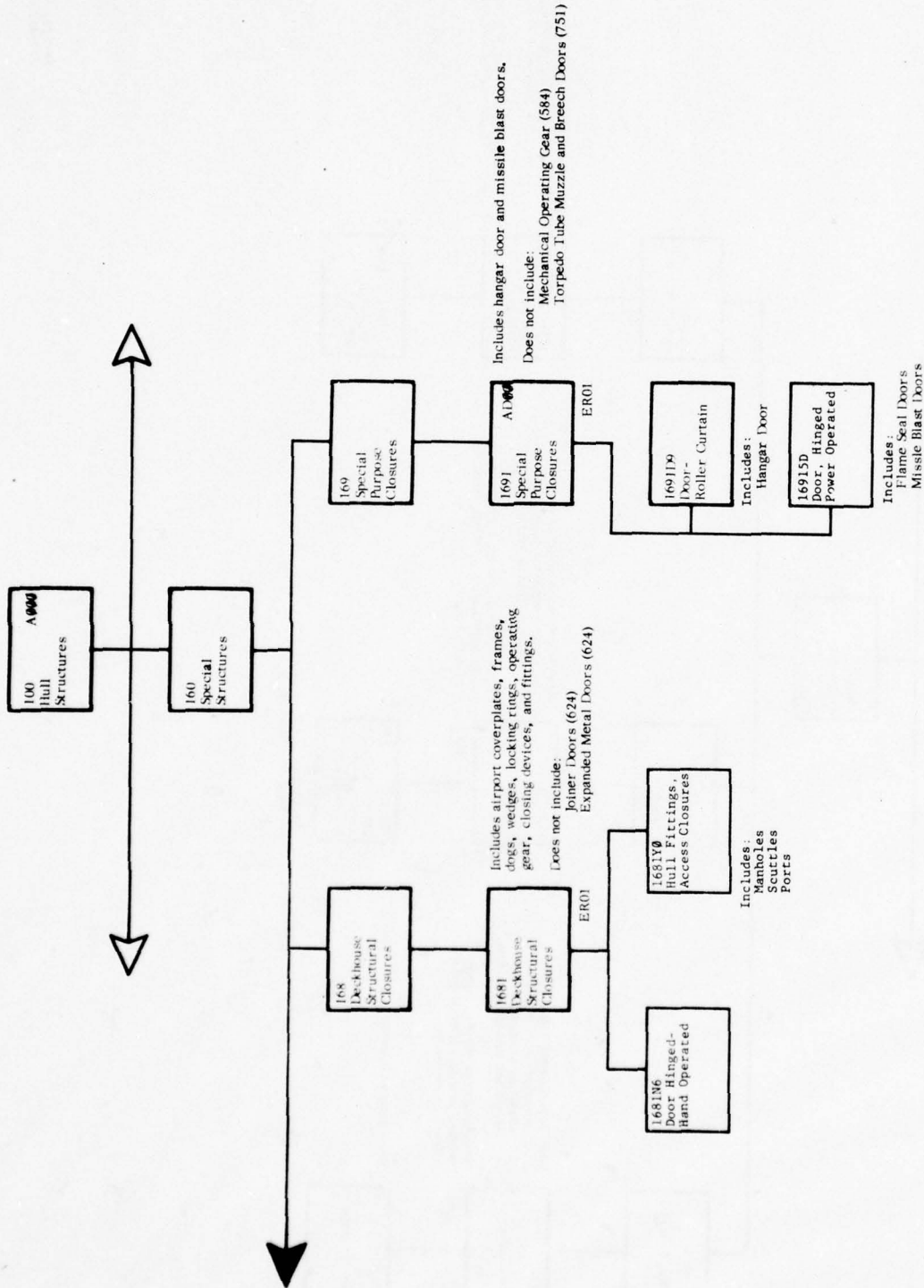

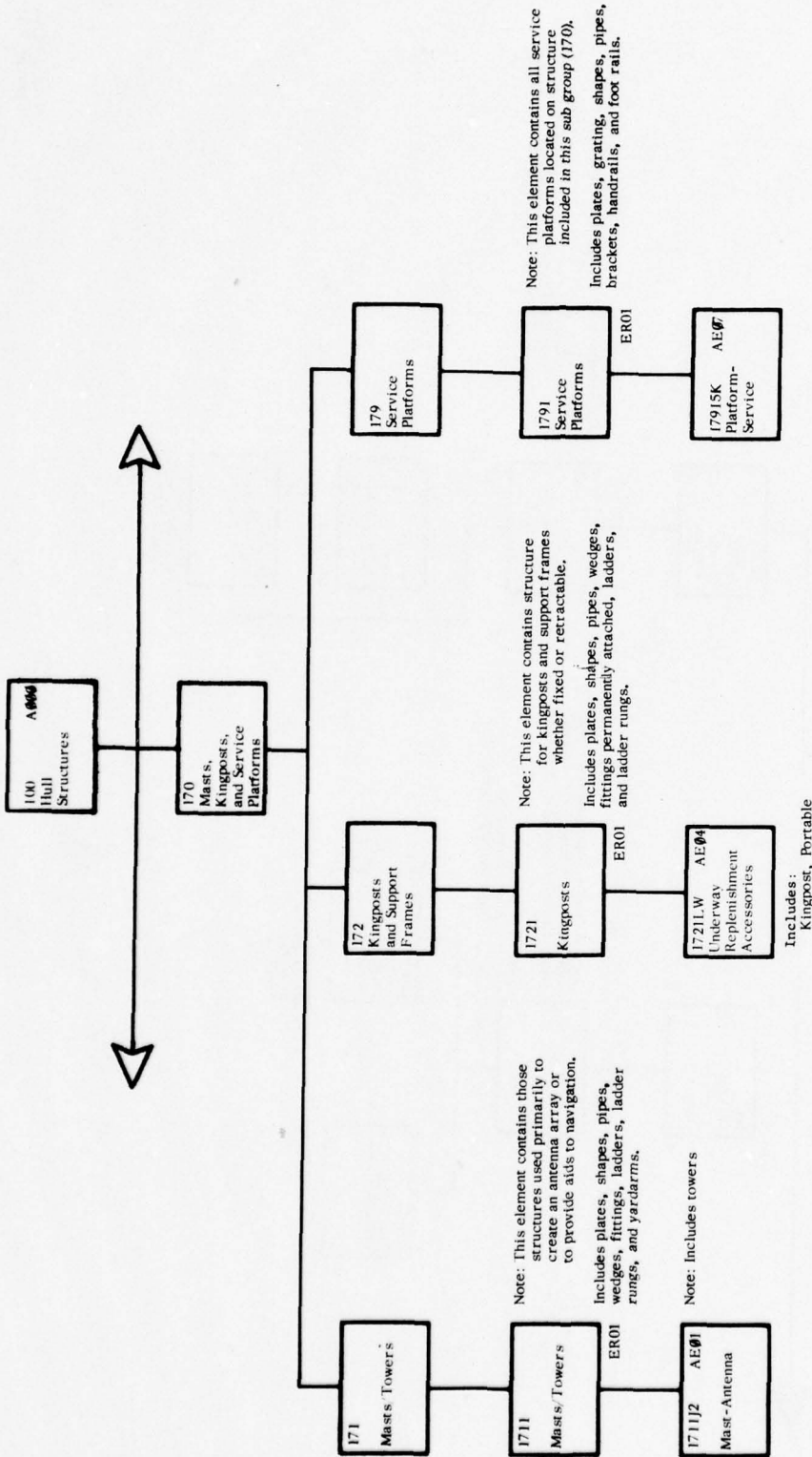

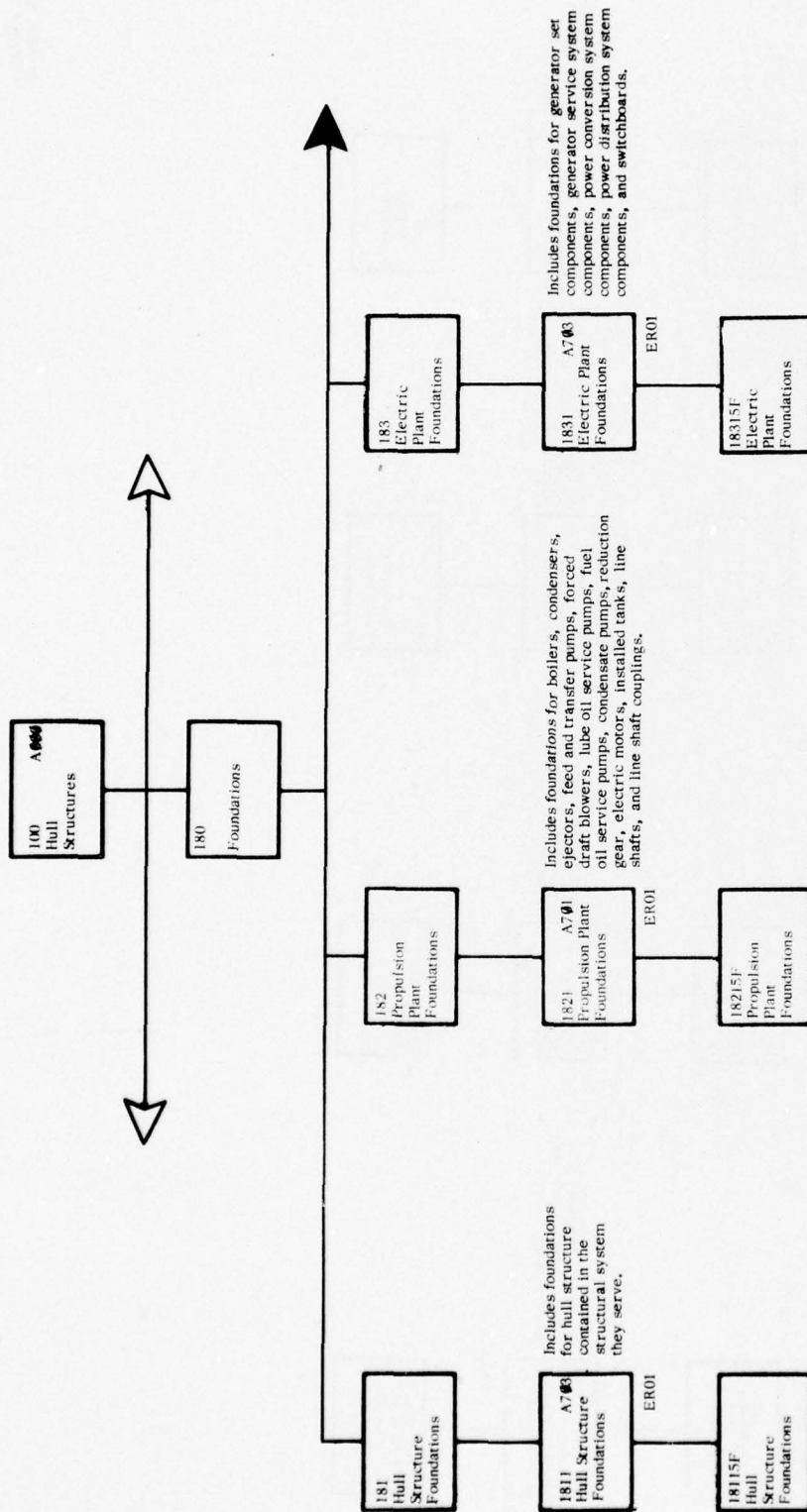

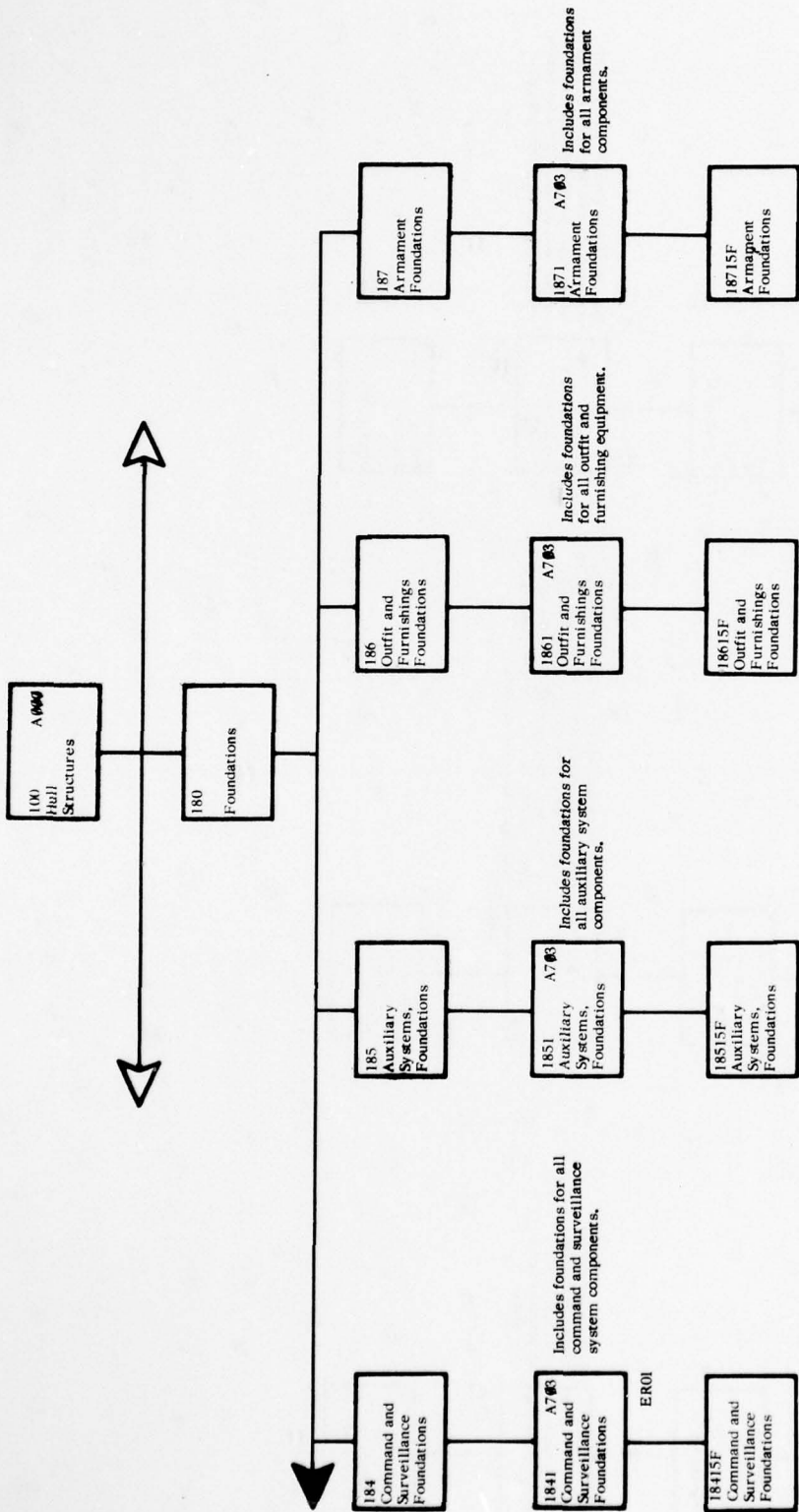

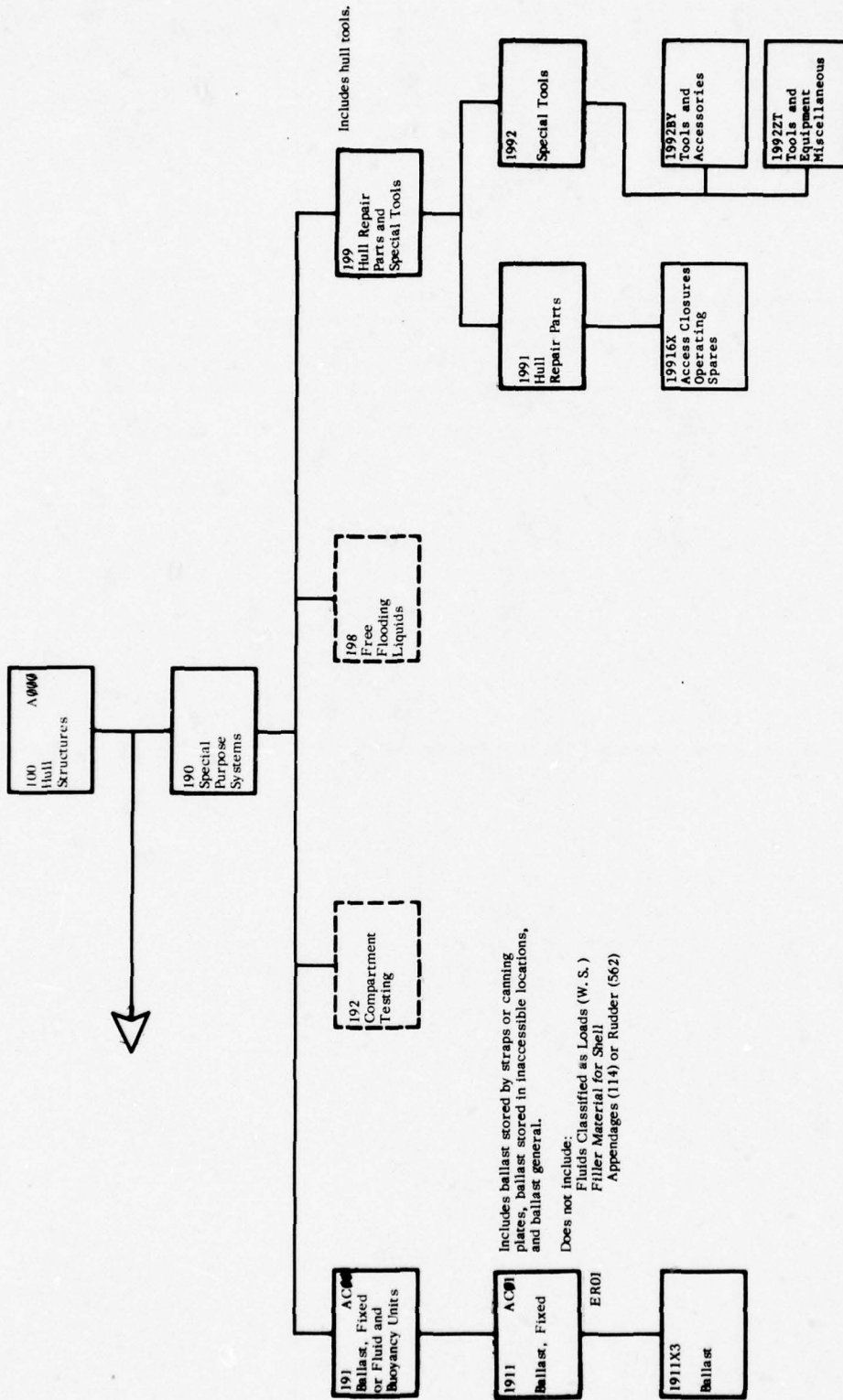

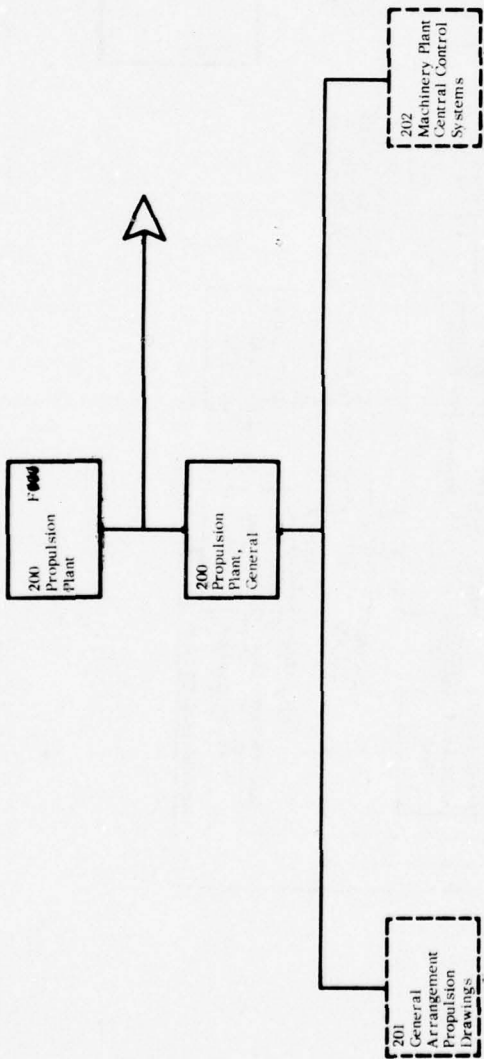

FF-1052 Class  
Prepared 7-19-76

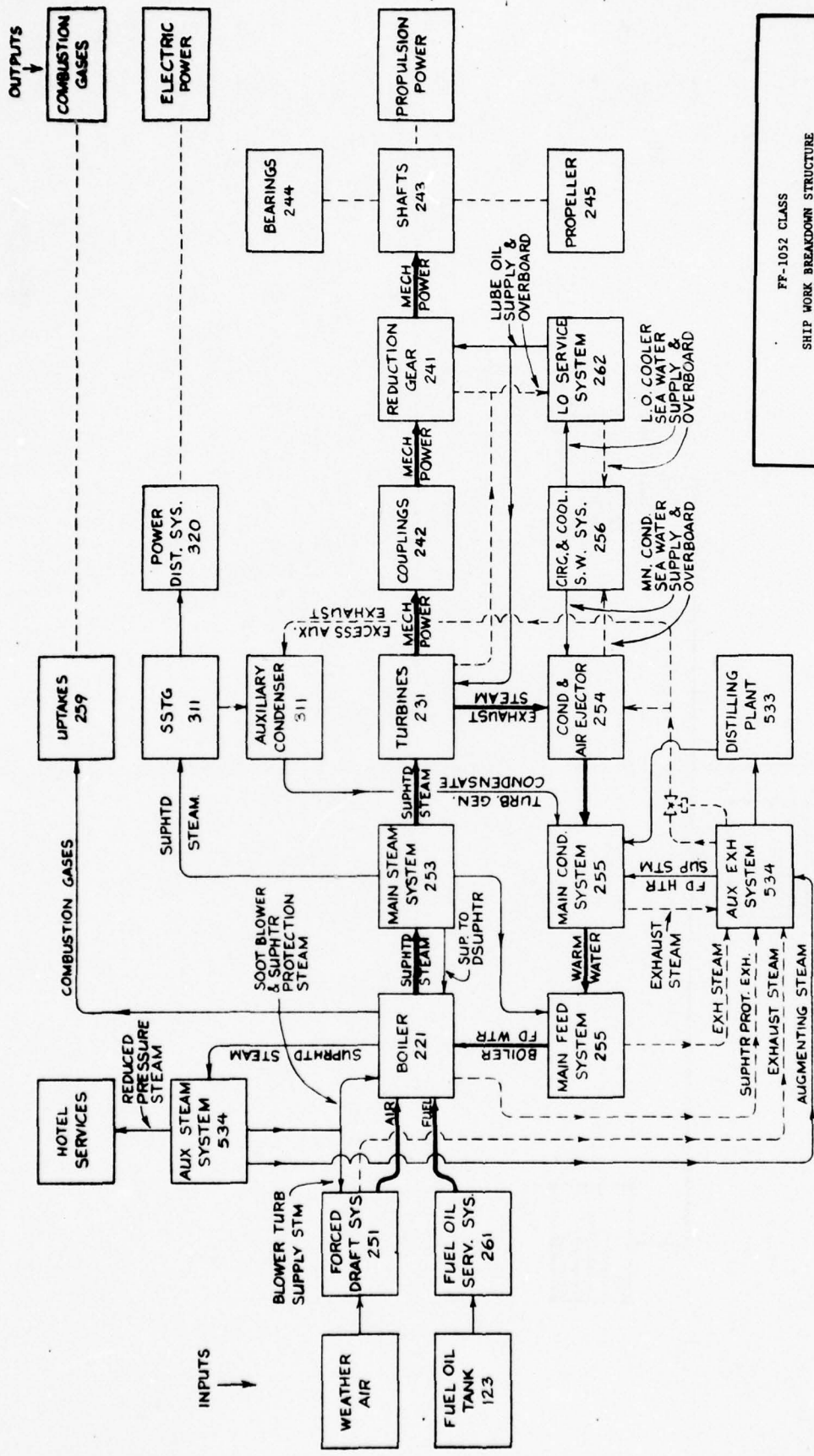

FF-1052 CLASS  
 SHIP WORK BREAKDOWN STRUCTURE  
 SHBS SHIP SYSTEM DIAGRAM  
 200 PROPULSION PLANT  
 INDEX

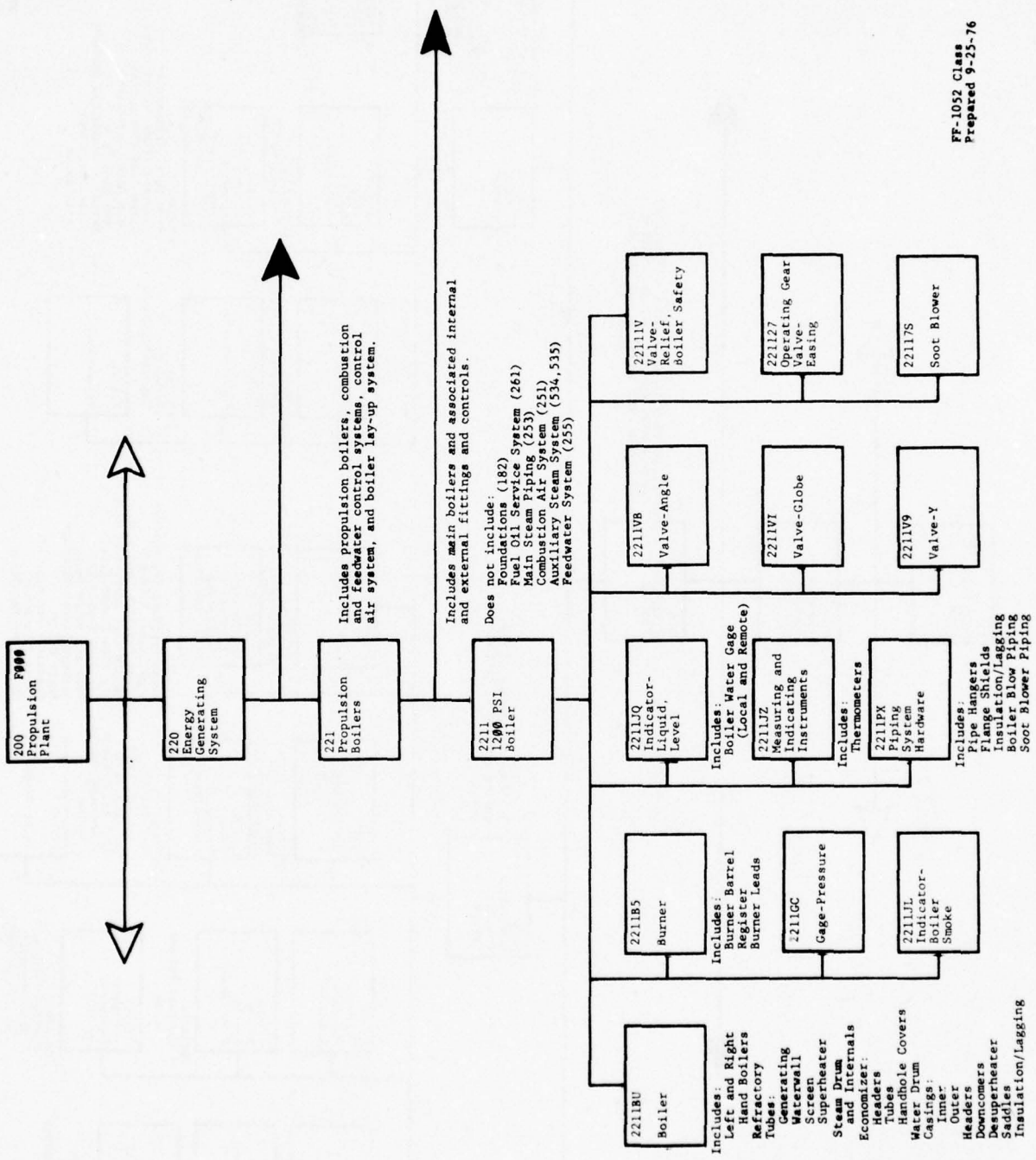

FF-1052 Class  
Prepared 9-25-76

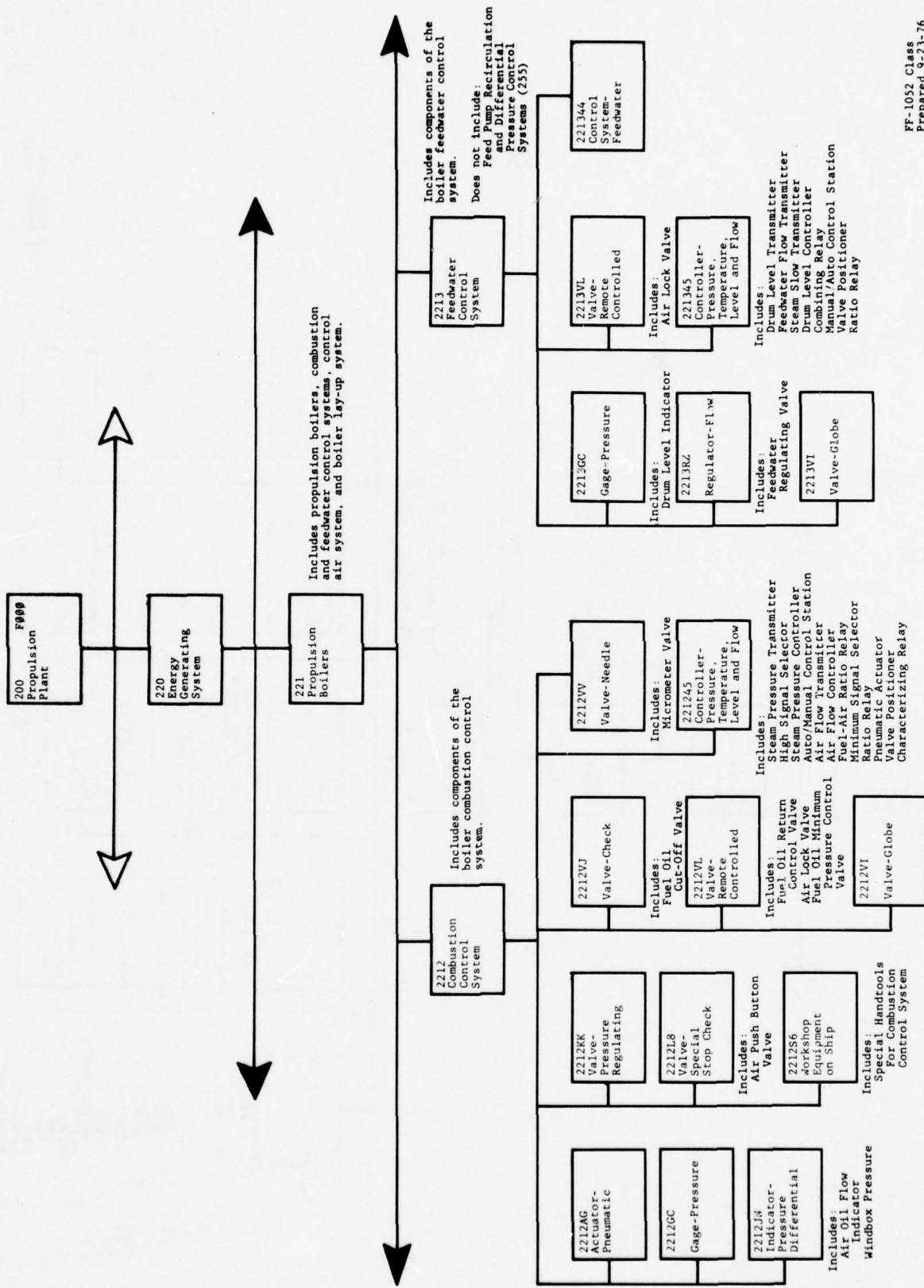

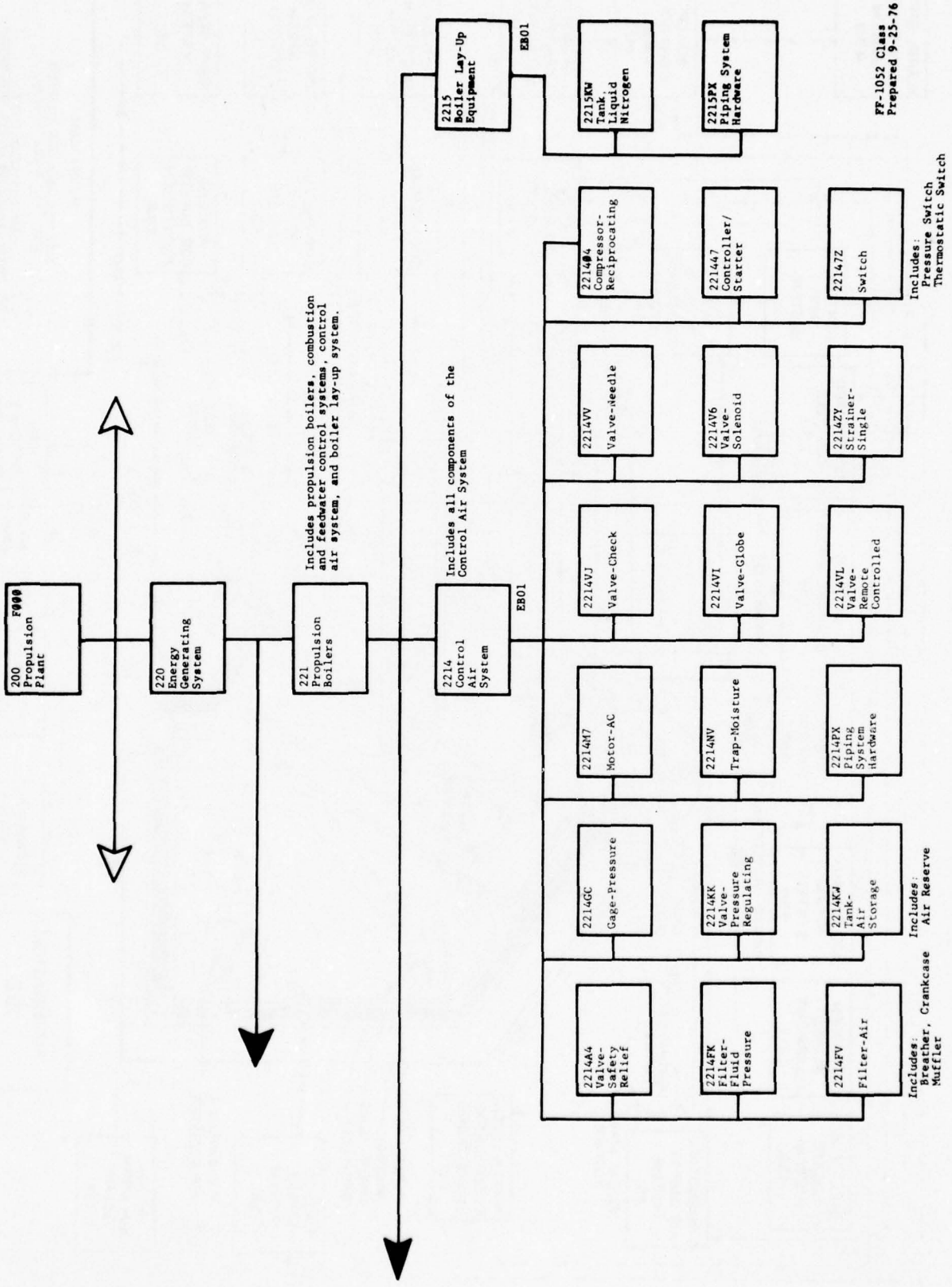

FF-1052 Class  
Prepared 9-25-76

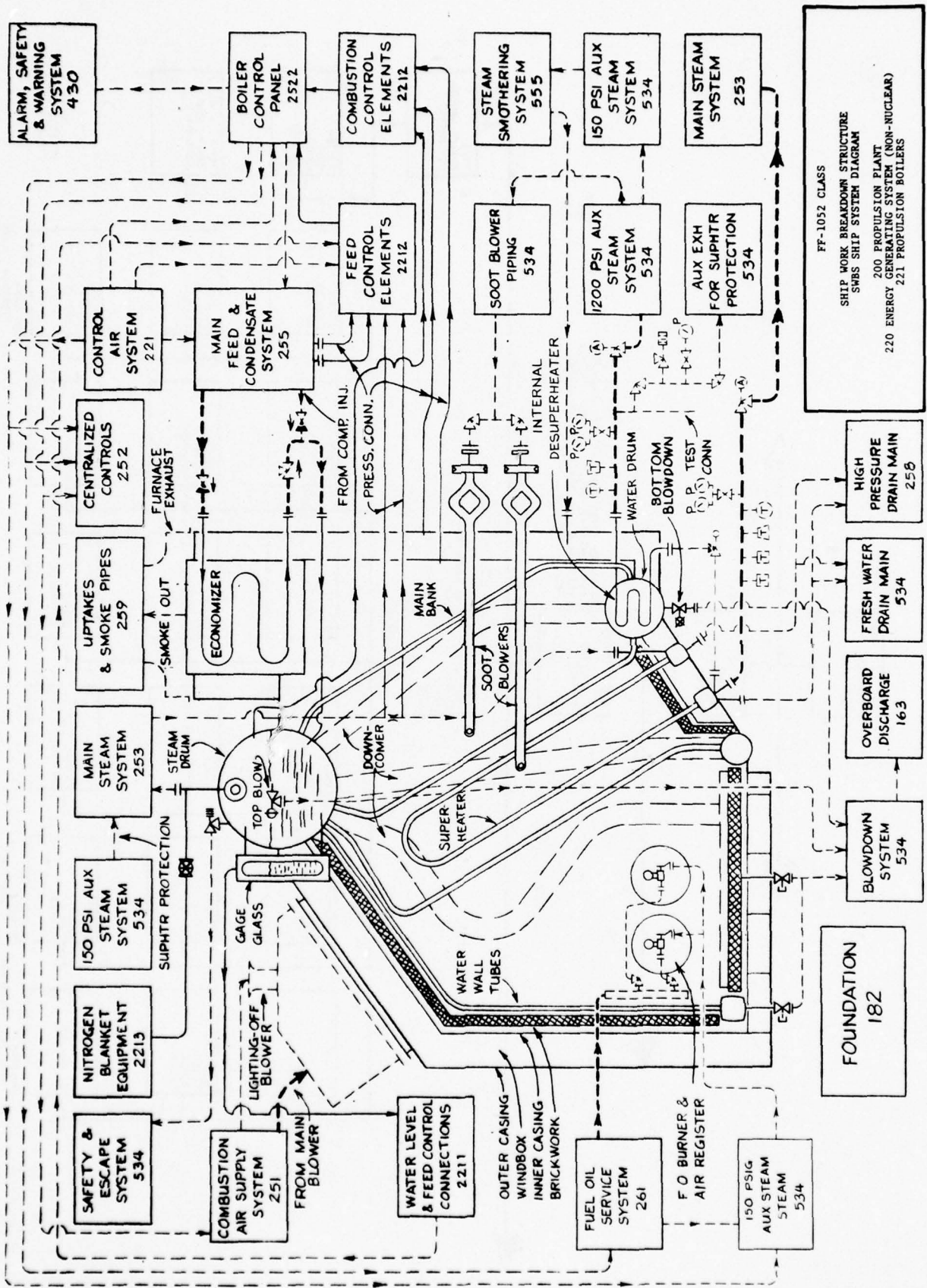

FF-1052 CLASS  
 SHIP WORK BREAKDOWN STRUCTURE  
 SWBS SHIP SYSTEM DIAGRAM  
 200 PROPULSION PLANT  
 220 ENERGY GENERATING SYSTEM (NON-NUCLEAR)  
 221 PROPULSION BOILERS

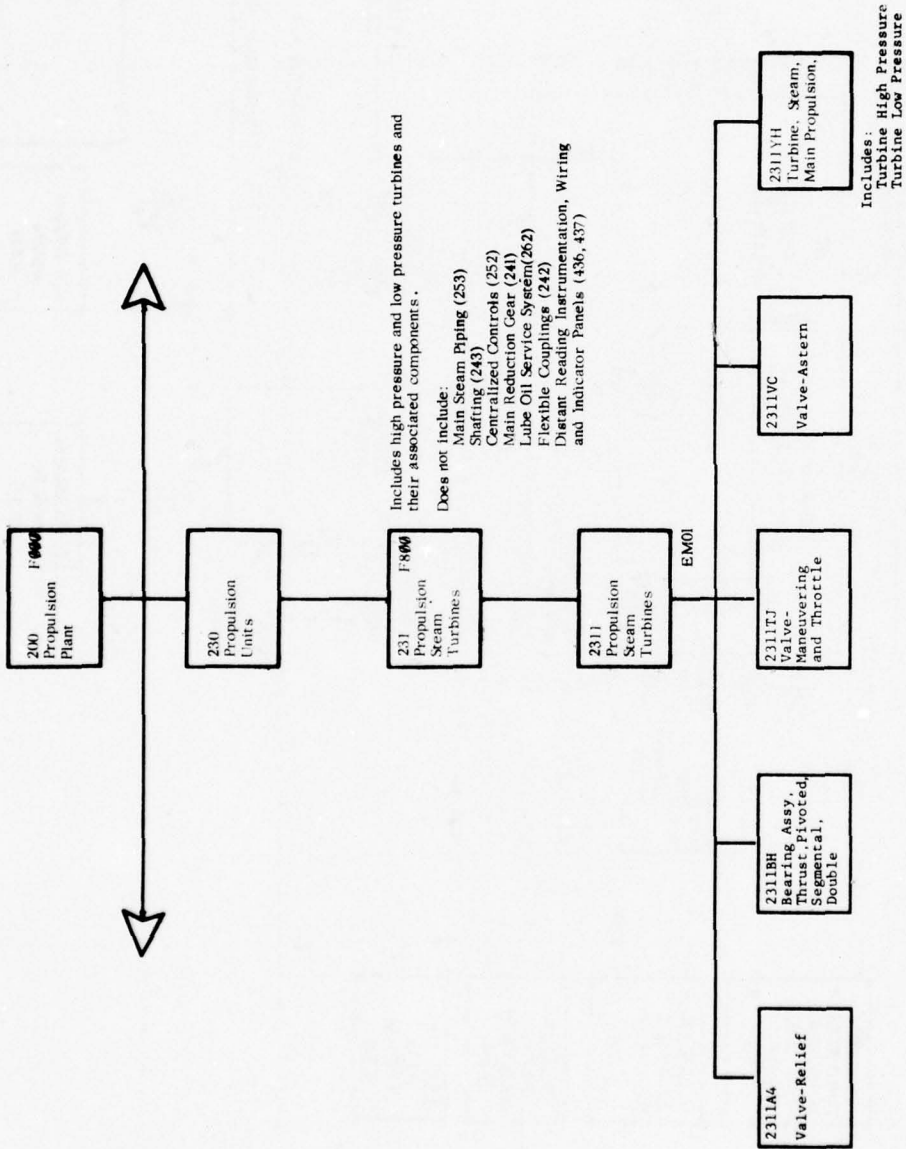

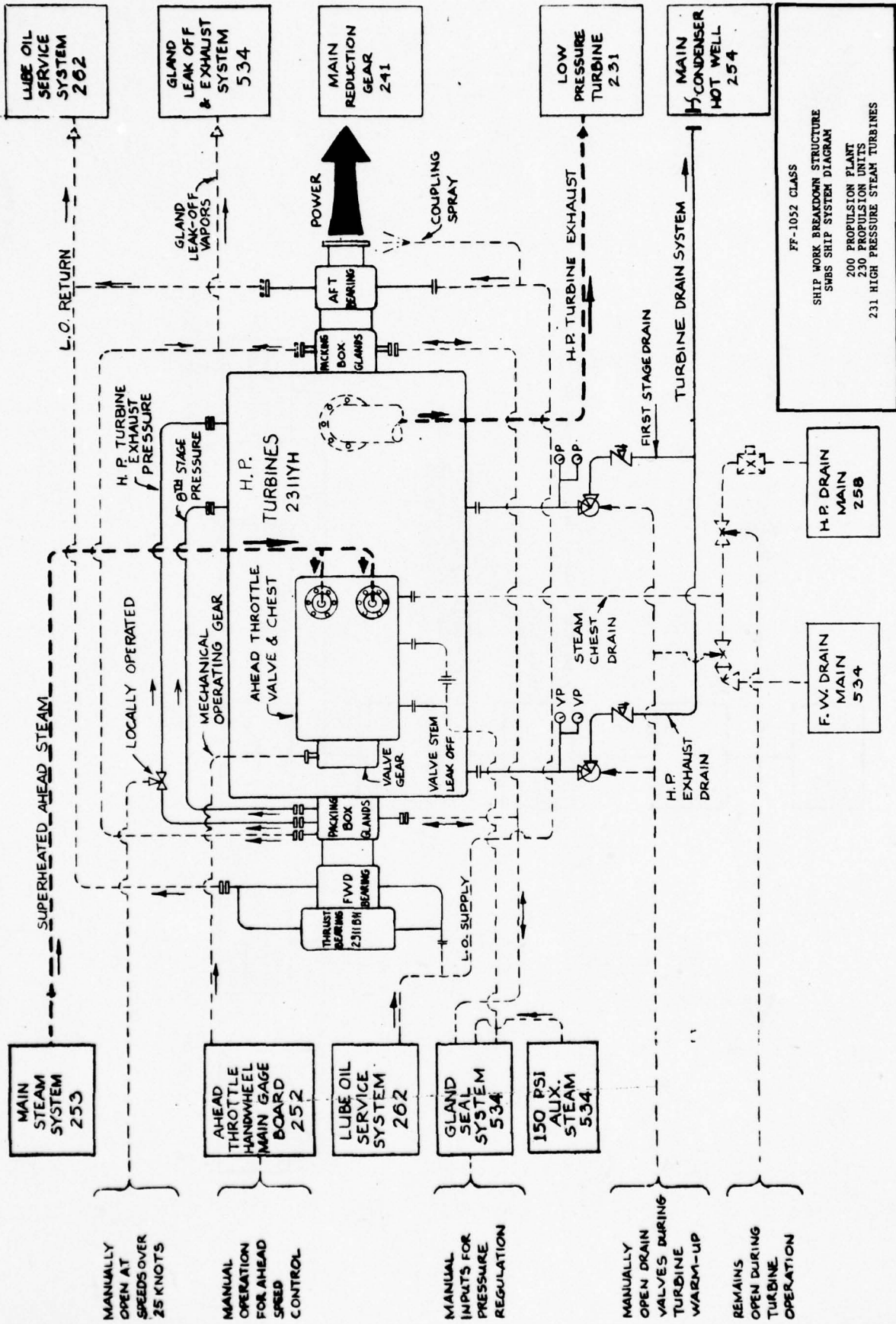

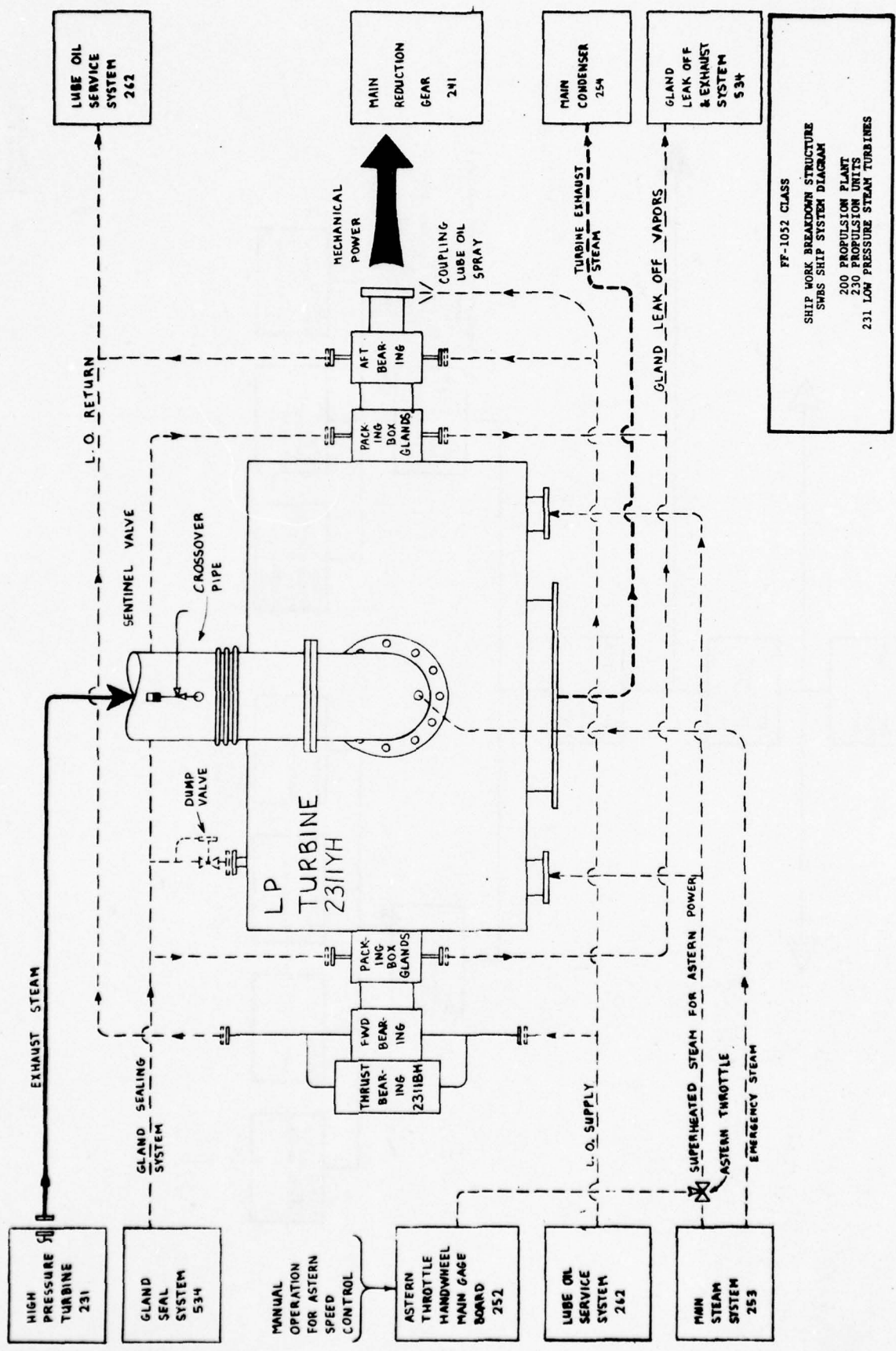

FF-1052 CLASS  
 SHIP WORK BREAKDOWN STRUCTURE  
 SHRS SHIP SYSTEM DIAGRAM  
 200 PROPULSION PLANT  
 230 PROPULSION UNITS  
 231 LOW PRESSURE STEAM TURBINES

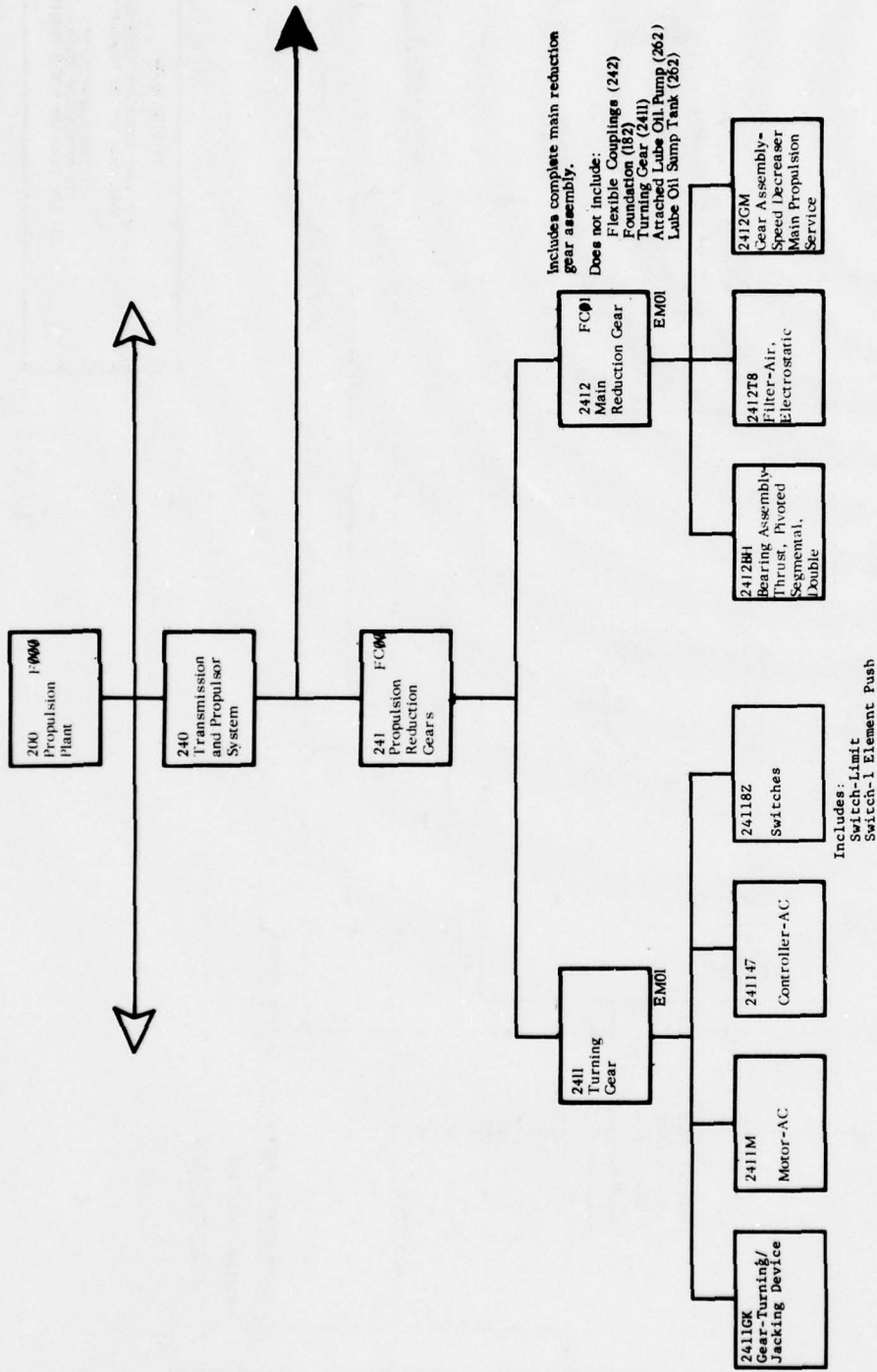

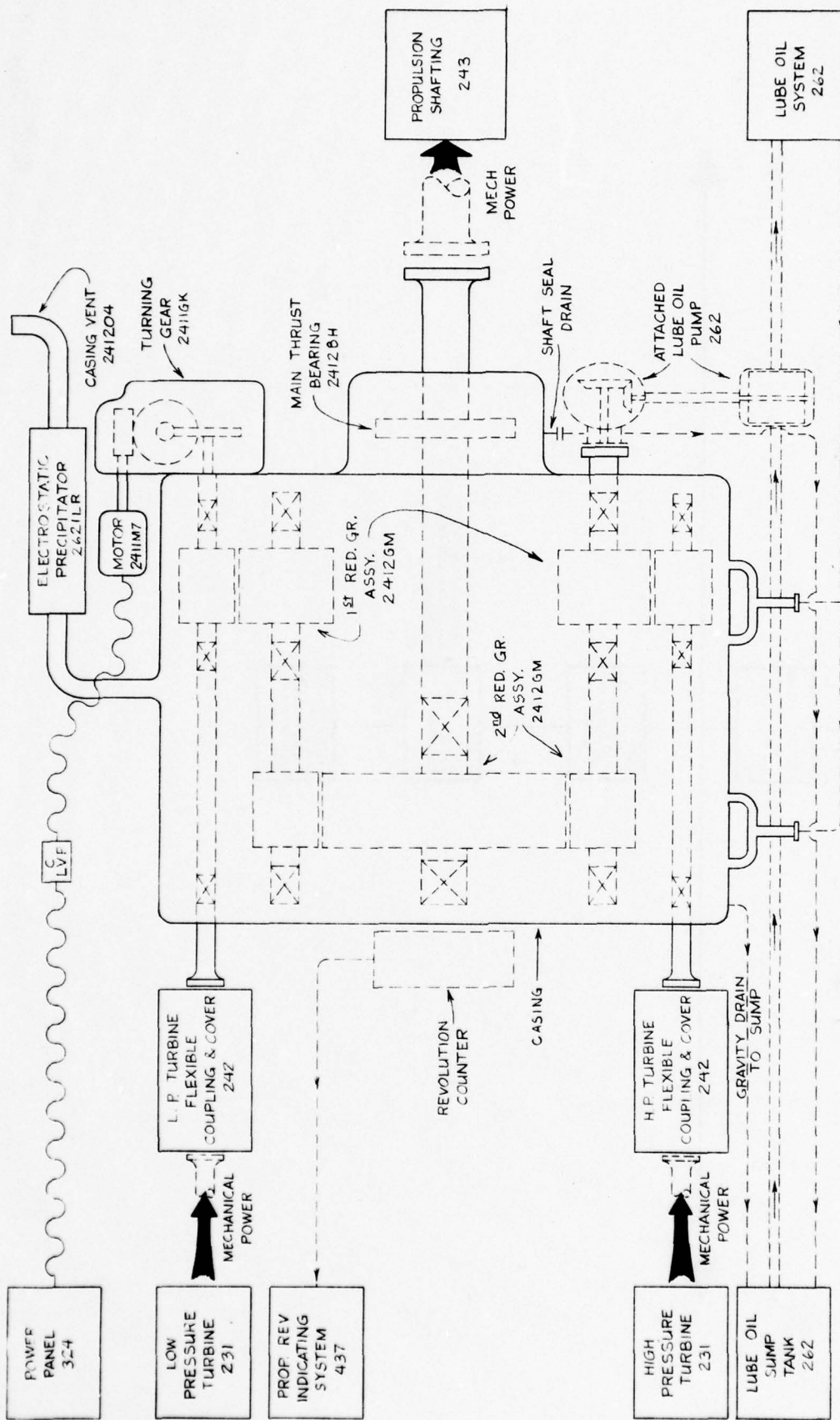

FF-1052 CLASS  
 SHIP WORK BREAKDOWN STRUCTURE  
 SWBS SHIP SYSTEM DIAGRAM  
 200 PROPULSION PLANT  
 240 TRANSMISSION AND PROPULSOR SYSTEMS  
 241 PROPULSION REDUCTION GEARS

FOUNDATION  
 182

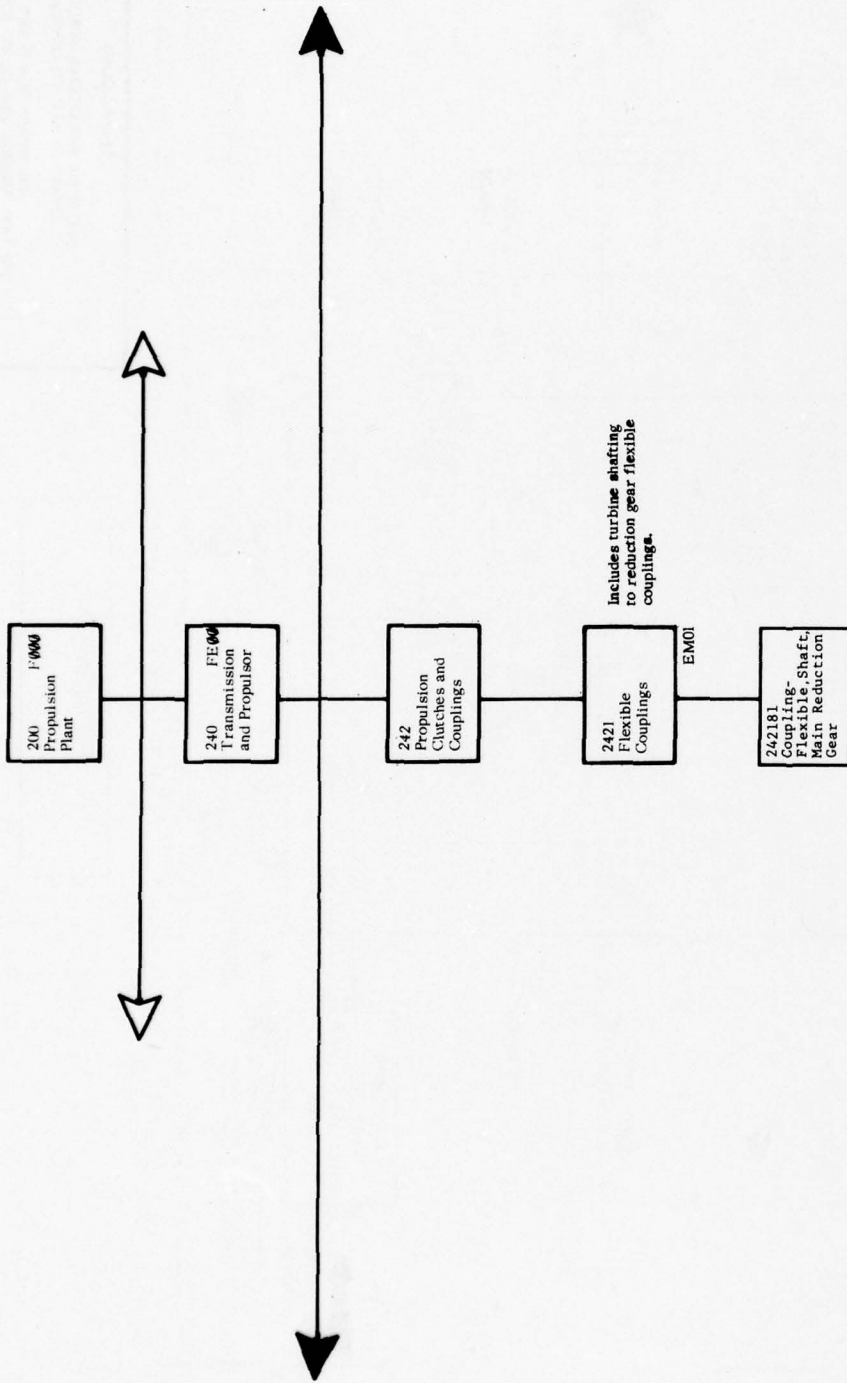

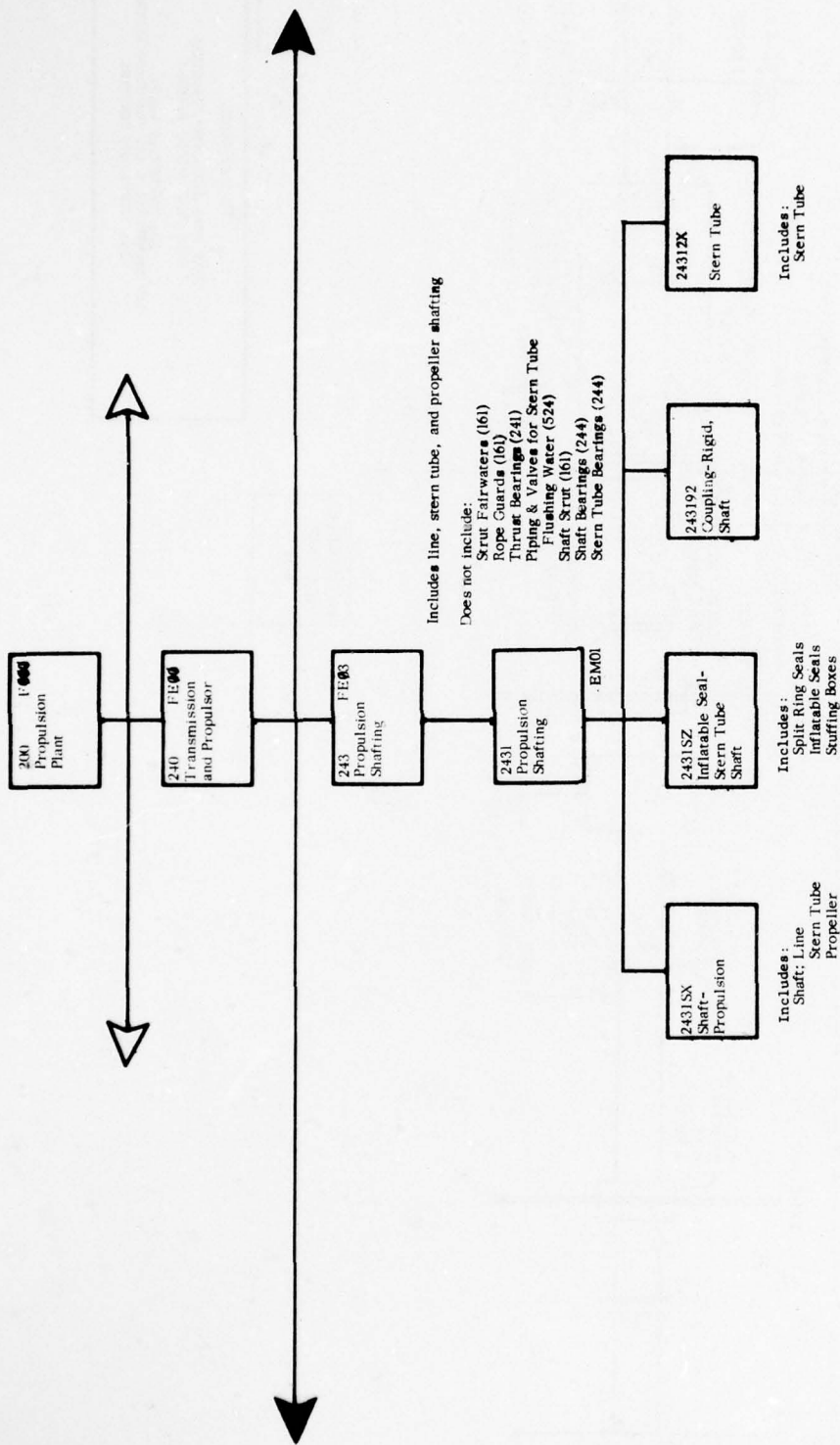

SHAFTING  
MAIN PROPULSION  
243

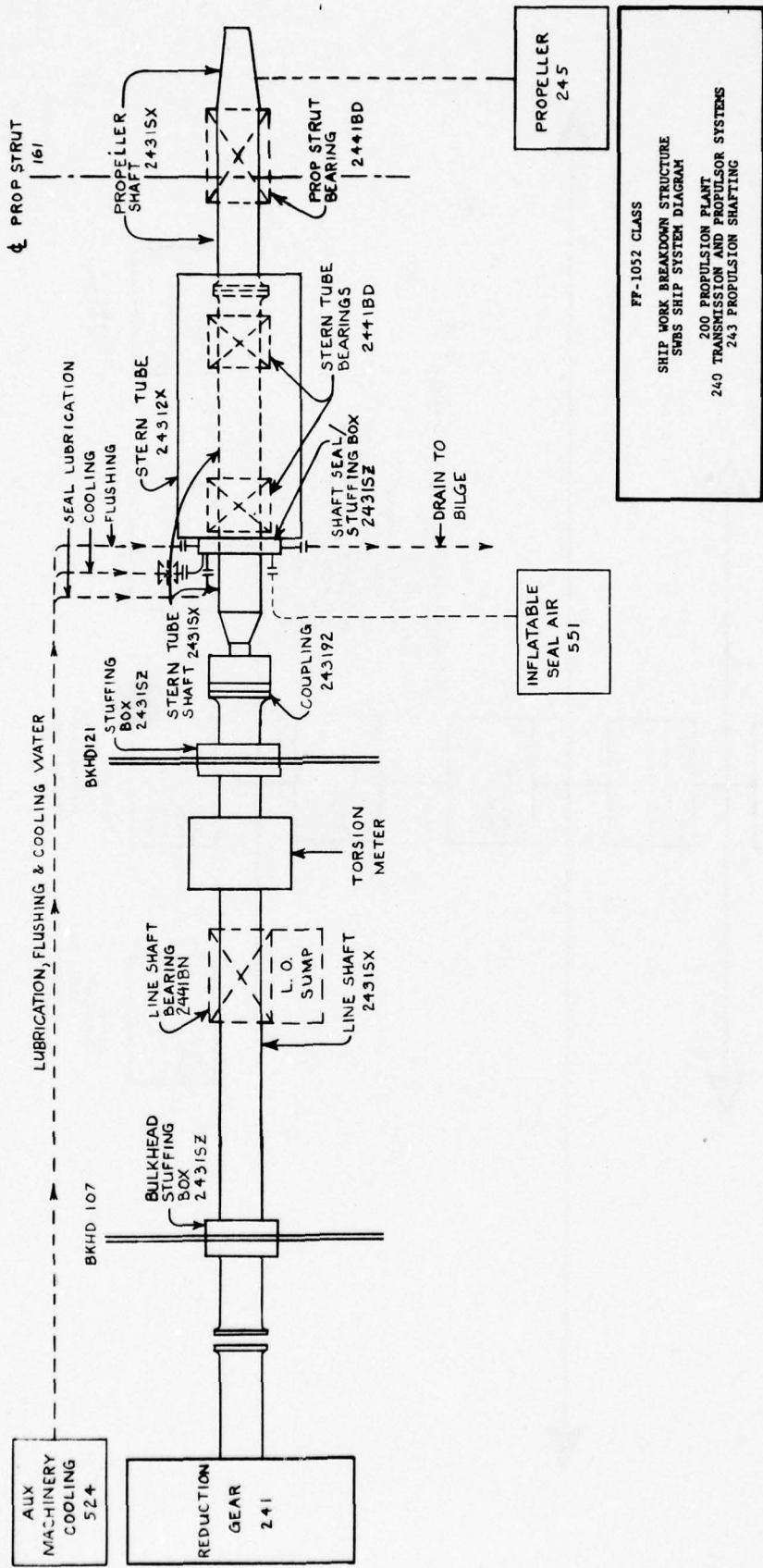

FF-1052 CLASS  
SHIP WORK BREAKDOWN STRUCTURE  
SMB SYSTEM DIAGRAM  
200 PROPULSION PLANT  
TRANSMISSION AND PROPULSOR SYSTEMS  
243 PROPULSION SHAFTING

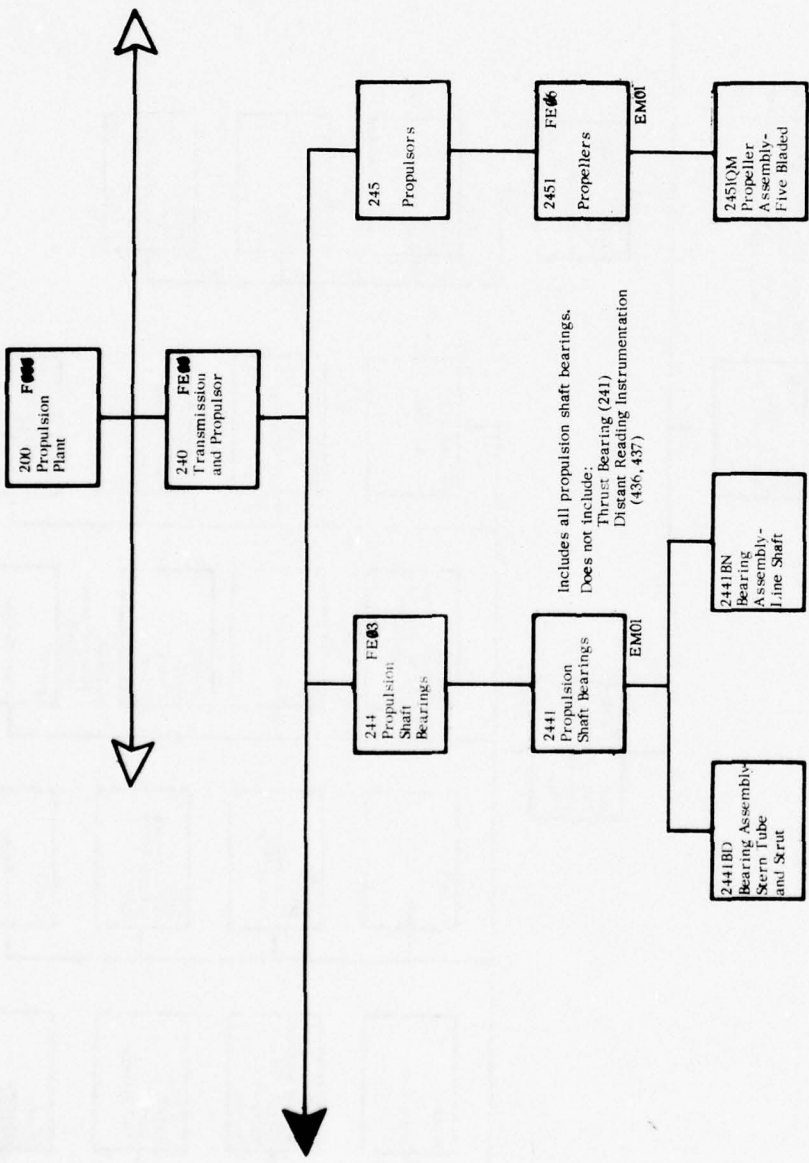

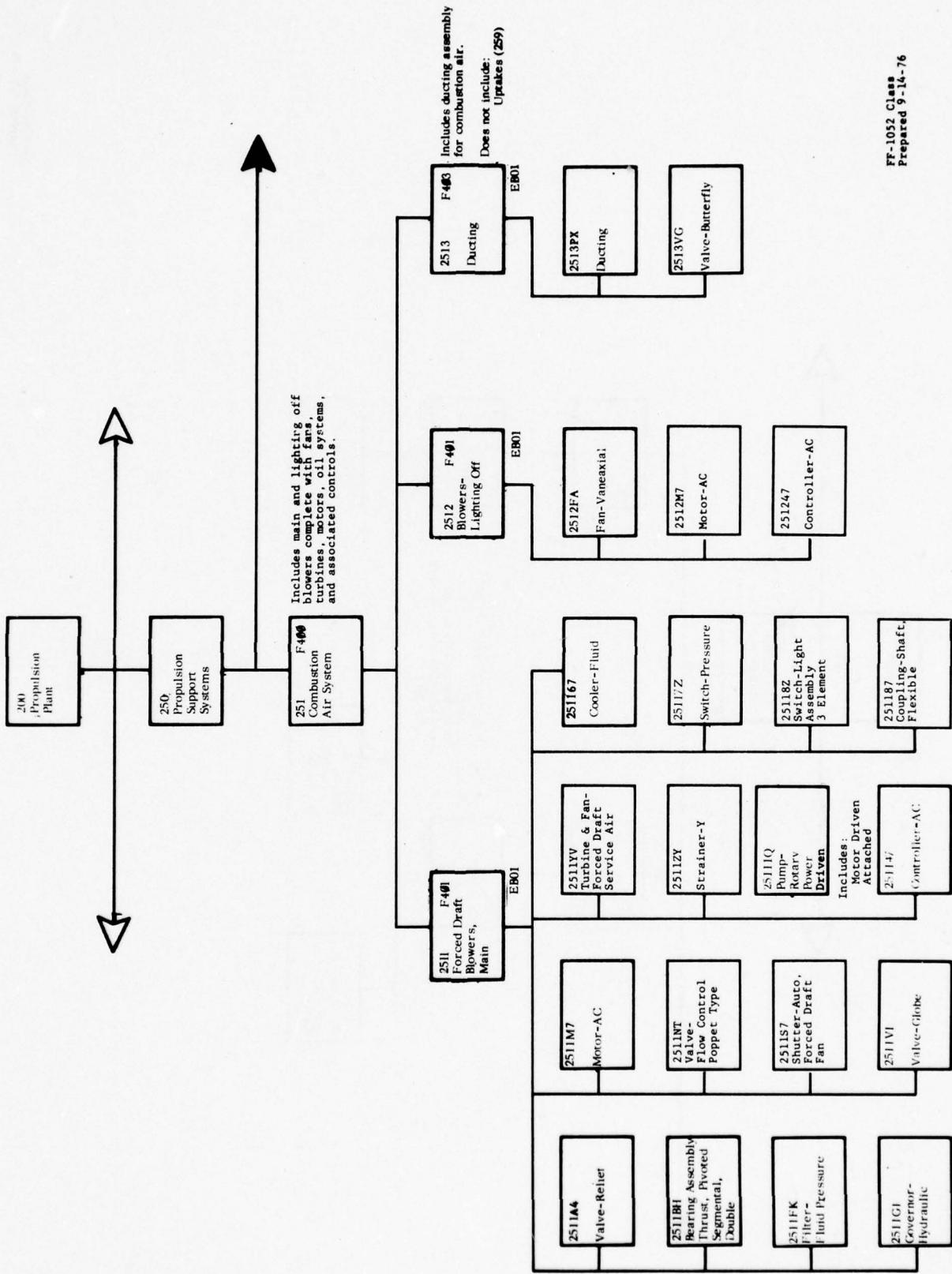

FF-1052 Class  
Prepared 9-14-76

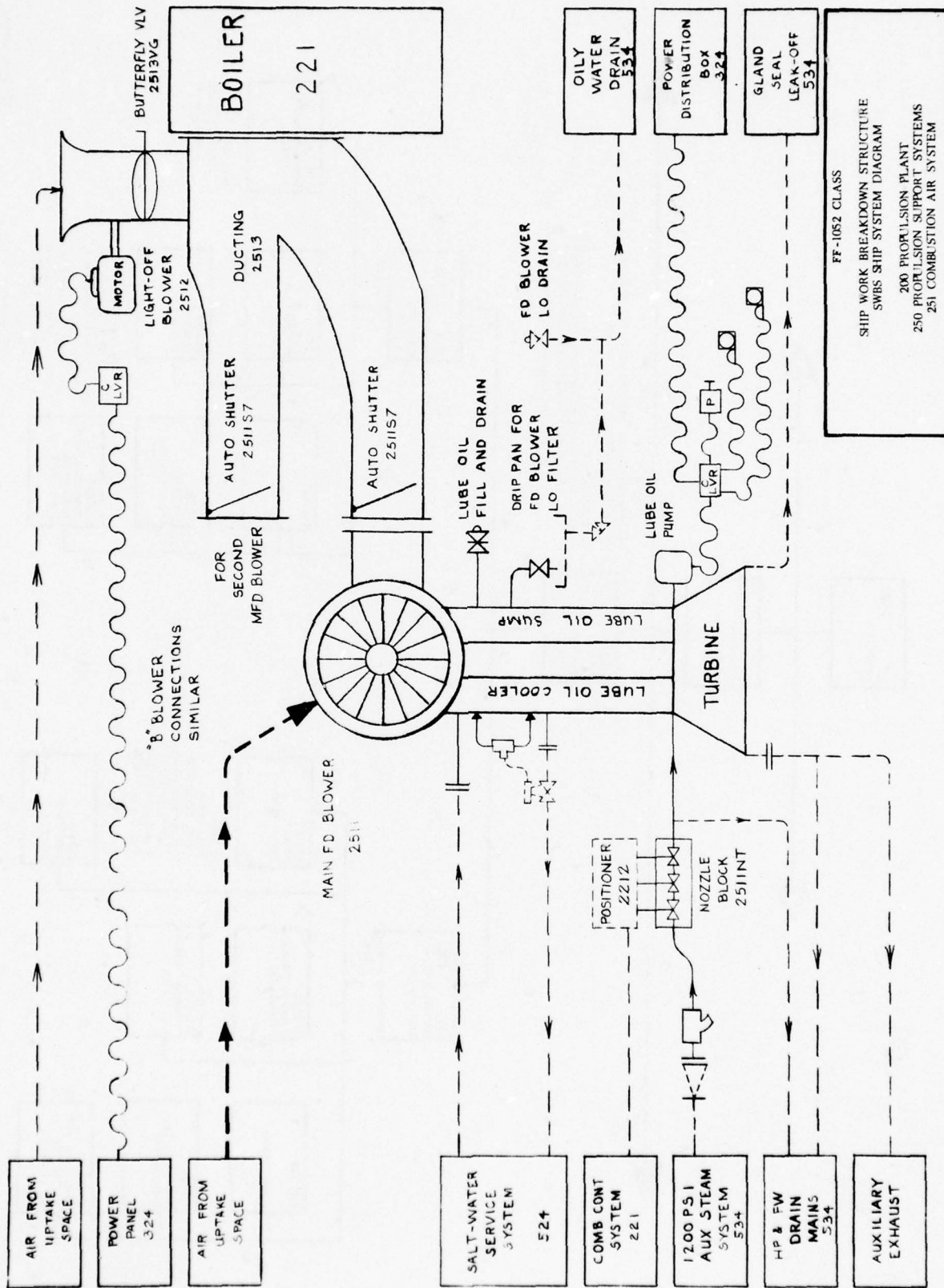

FF-1052 CLASS  
 SHIP WORK BREAKDOWN STRUCTURE  
 SWBS SHIP SYSTEM DIAGRAM  
 200 PROPULSION PLANT  
 250 PROPULSION SUPPORT SYSTEMS  
 251 COMBUSTION AIR SYSTEM

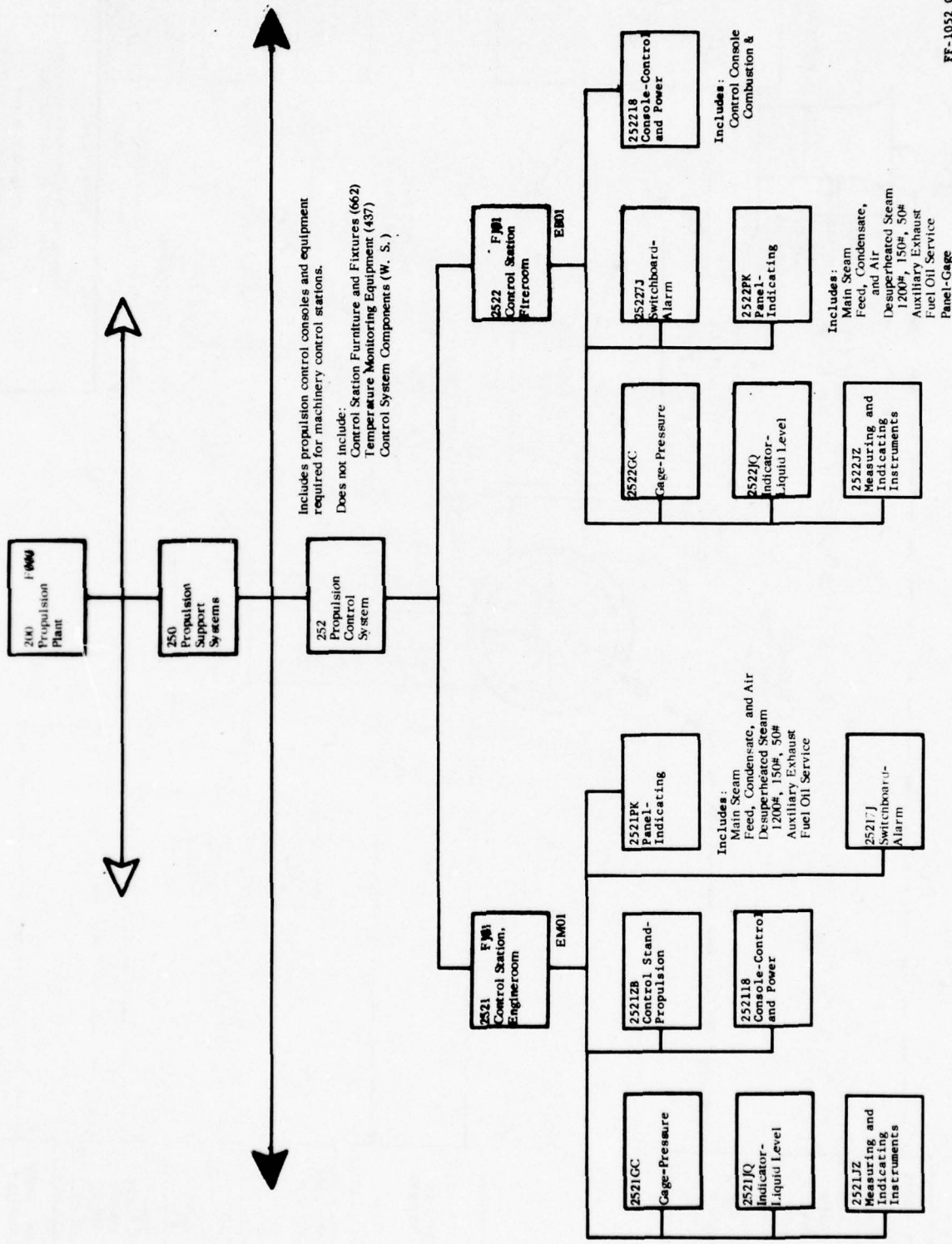

FF-1052 Class  
Prepared 7-19-76

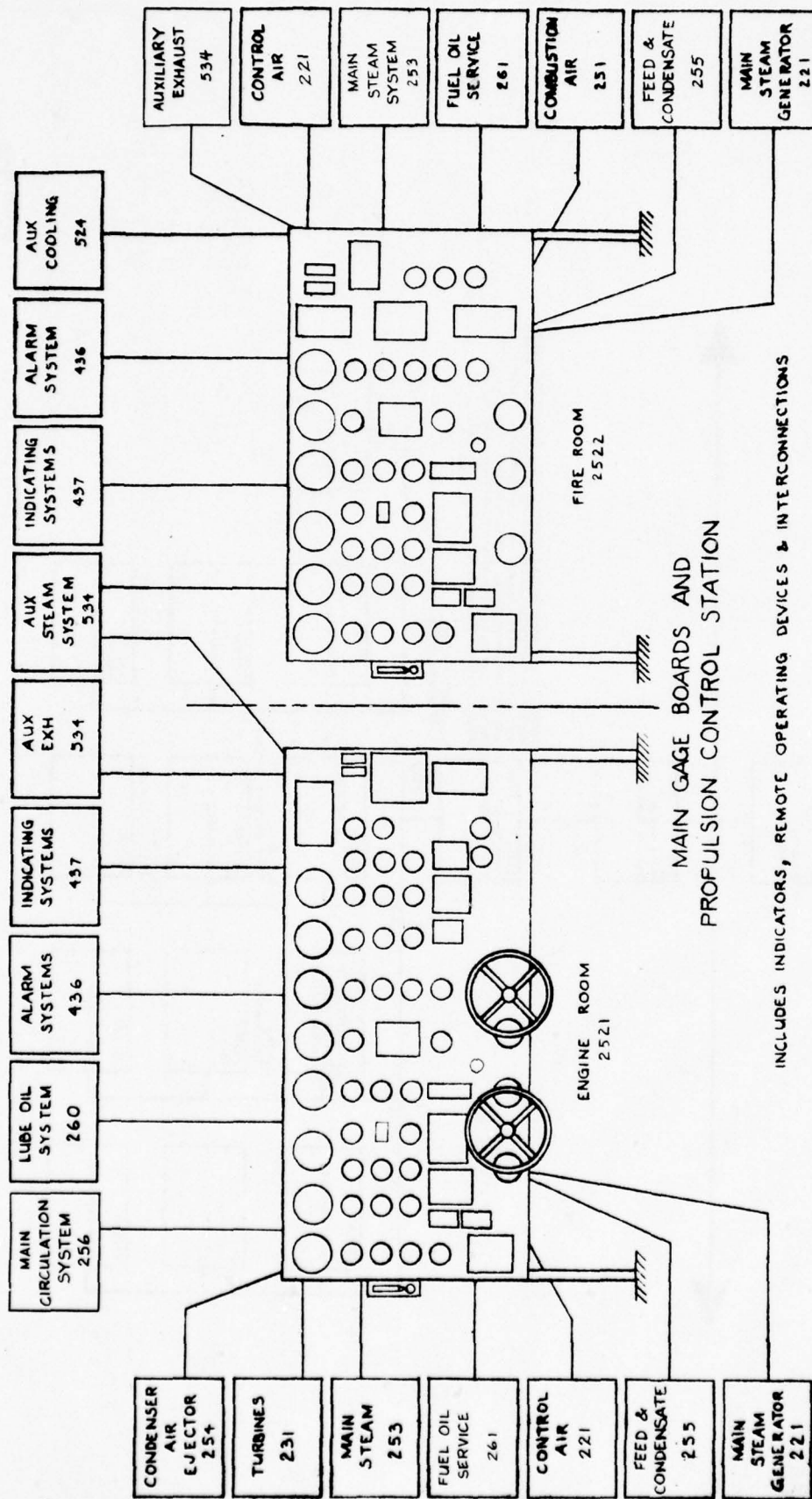

MAIN GAGE BOARDS AND  
PROPULSION CONTROL STATION

INCLUDES INDICATORS, REMOTE OPERATING DEVICES & INTERCONNECTIONS

FF-1052 CLASS  
SHIP WORK BREAKDOWN STRUCTURE  
SWBS SHIP SYSTEM DIAGRAM  
200 PROPULSION PLANT  
250 PROPULSION SUPPORT SYSTEMS  
252 PROPULSION CONTROL SYSTEM

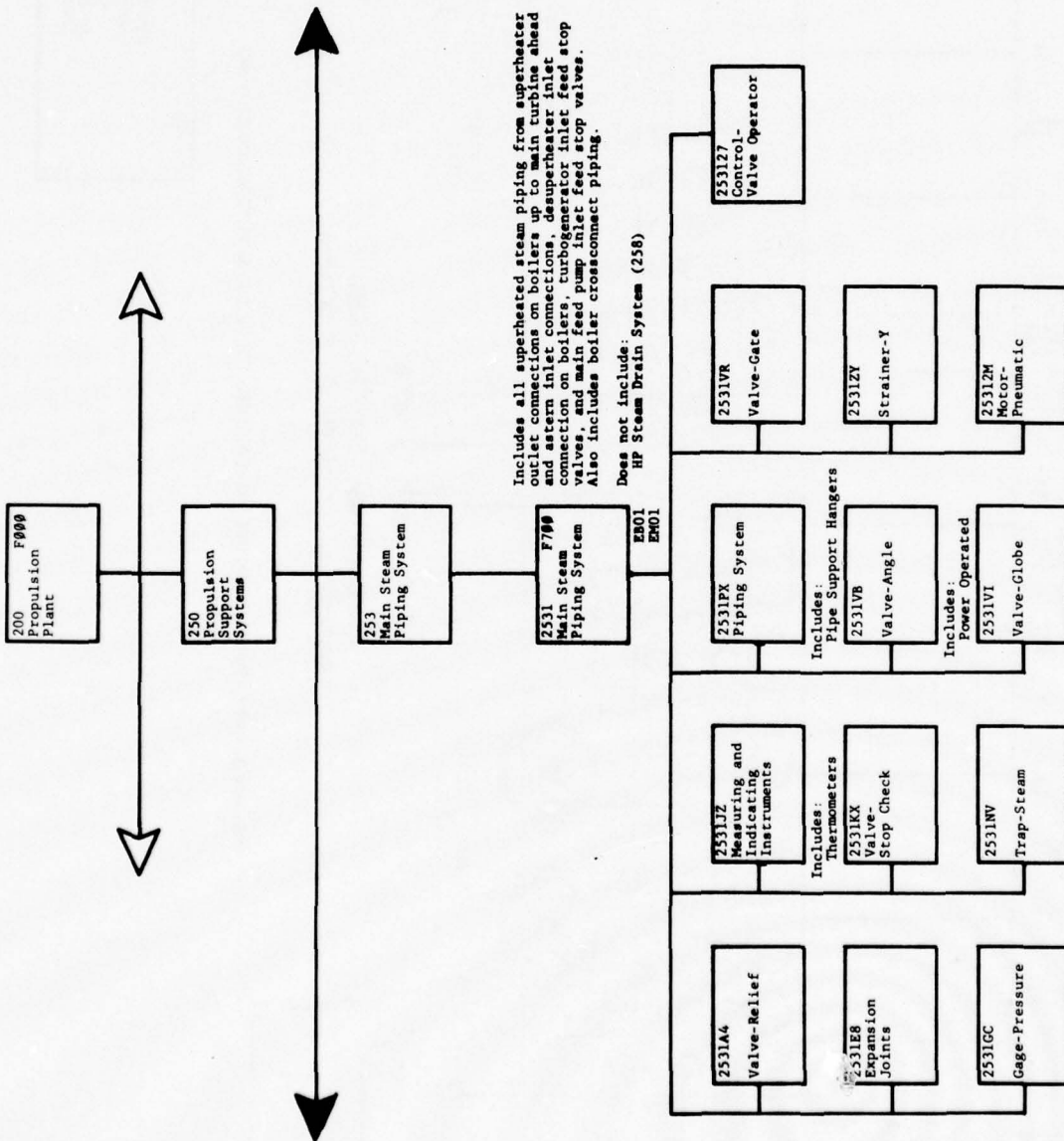

Mechanical operating gear from Eng room control station. The handwheel shall be made inoperable at all times except when needed for the emergency operation of the L. P. turbine, with the H. P. turbine inoperative.

Local Manual, Pneumatically (for closing only) from Eng room control station.

Mechanical operating gear from Eng room control station.

150 PSIG  
AUX STM  
534

Local Manual, Pneumatically (for closing only) from the fire room control station and fire room access on D. C. deck.

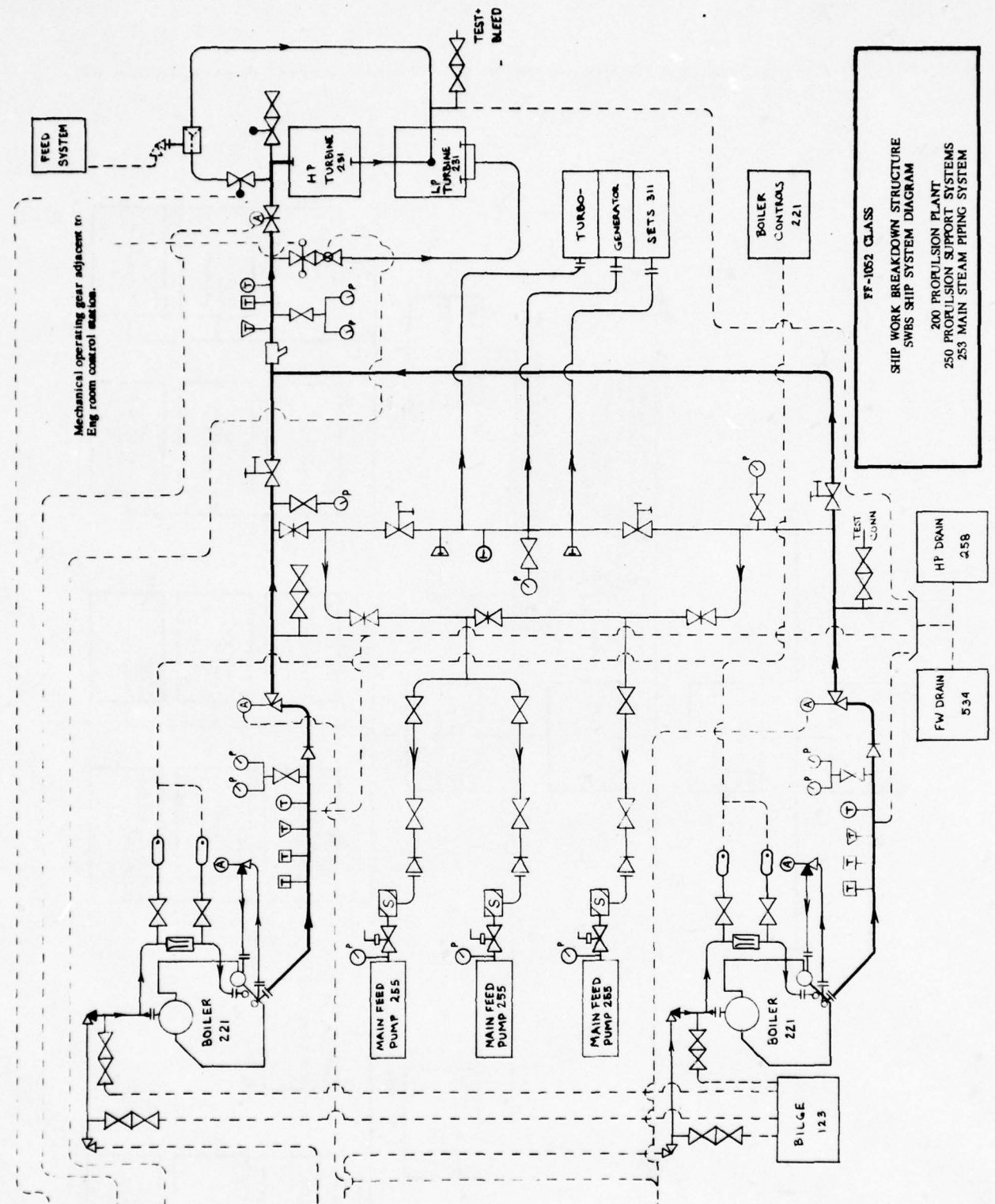

FF-1052 CLASS  
SHIP WORK BREAKDOWN STRUCTURE  
SWBS SHIP SYSTEM DIAGRAM  
200 PROPULSION PLANT  
250 PROPULSION SUPPORT SYSTEMS  
253 MAIN STEAM PIPING SYSTEM

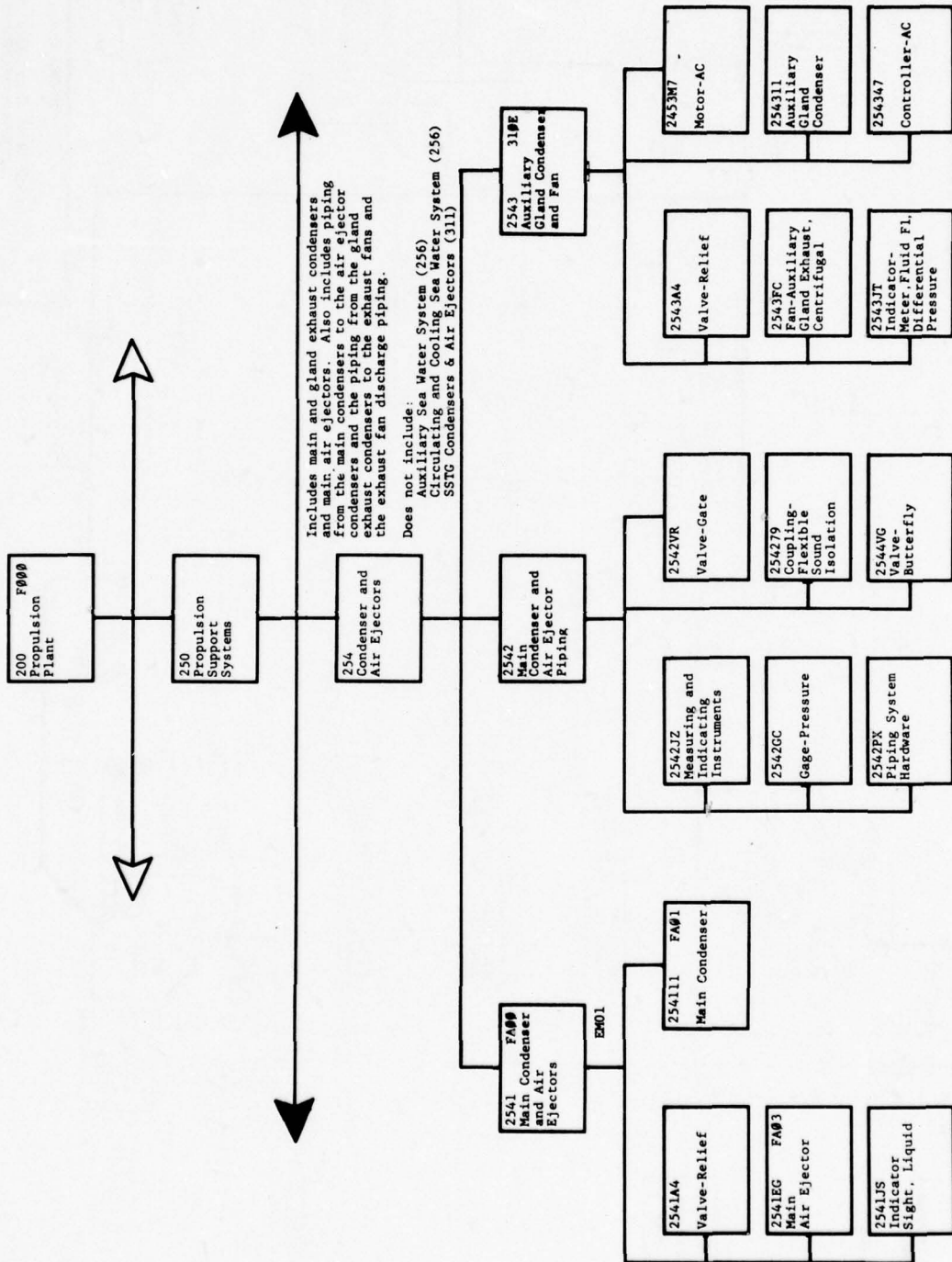

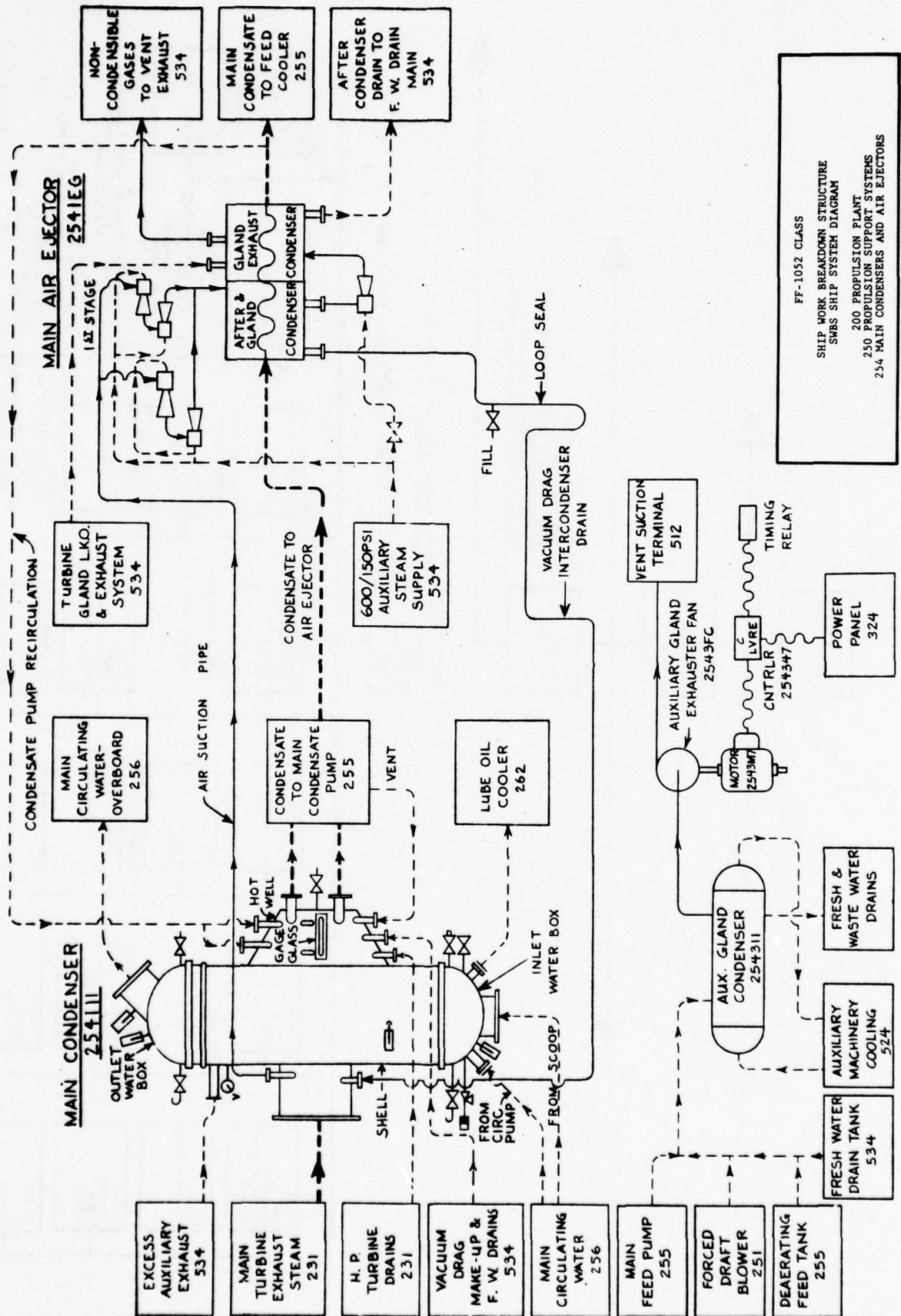

FF-1052 CLASS  
 SHIP WORK BREAKDOWN STRUCTURE  
 SMBS SHIP SYSTEM DIAGRAM  
 200 PROPULSION PLANT  
 250 PROPULSION SUPPORT SYSTEMS  
 254 MAIN CONDENSERS AND AIR EJECTORS

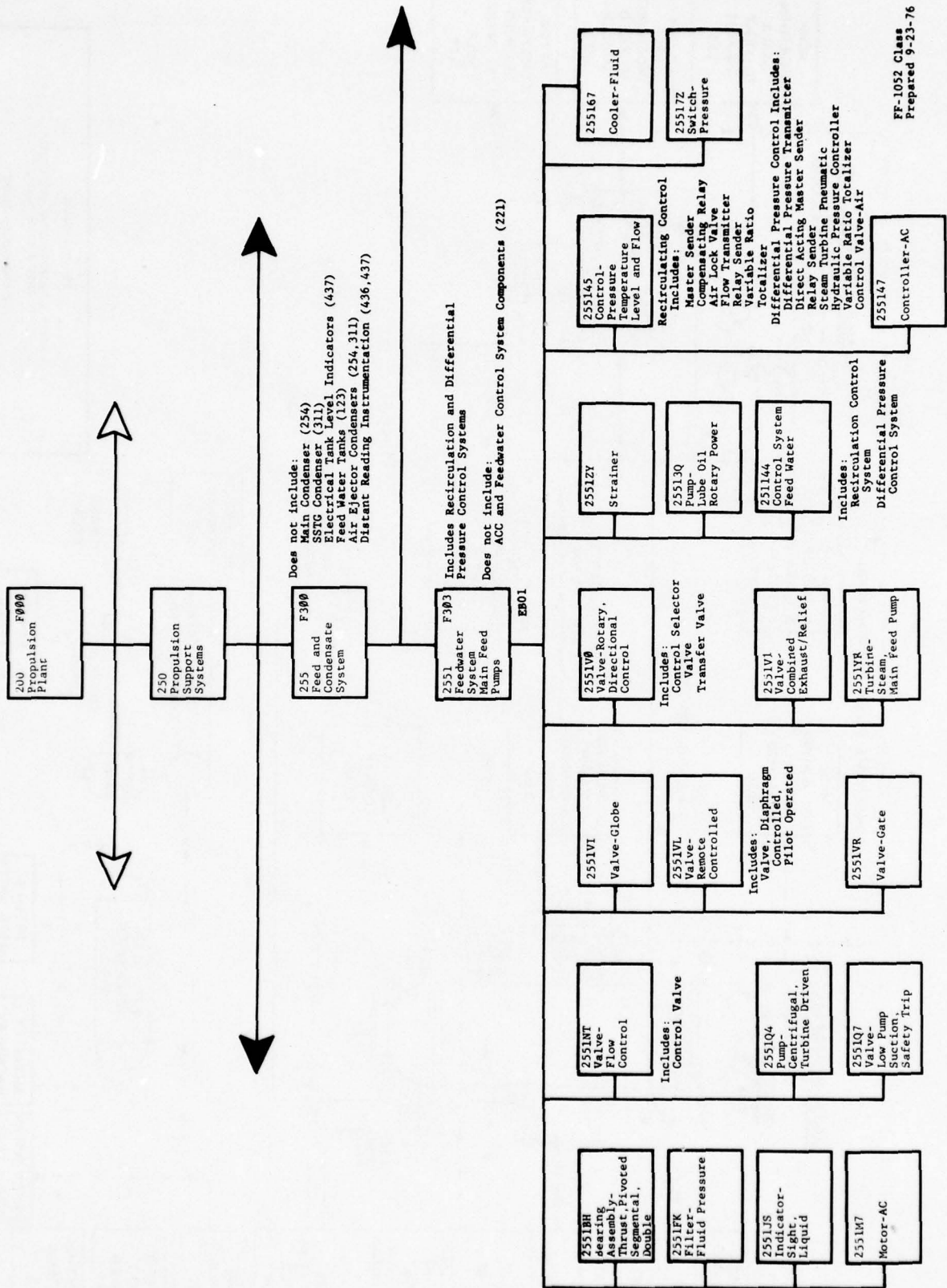

FF-1052 Class  
Prepared 9-23-76

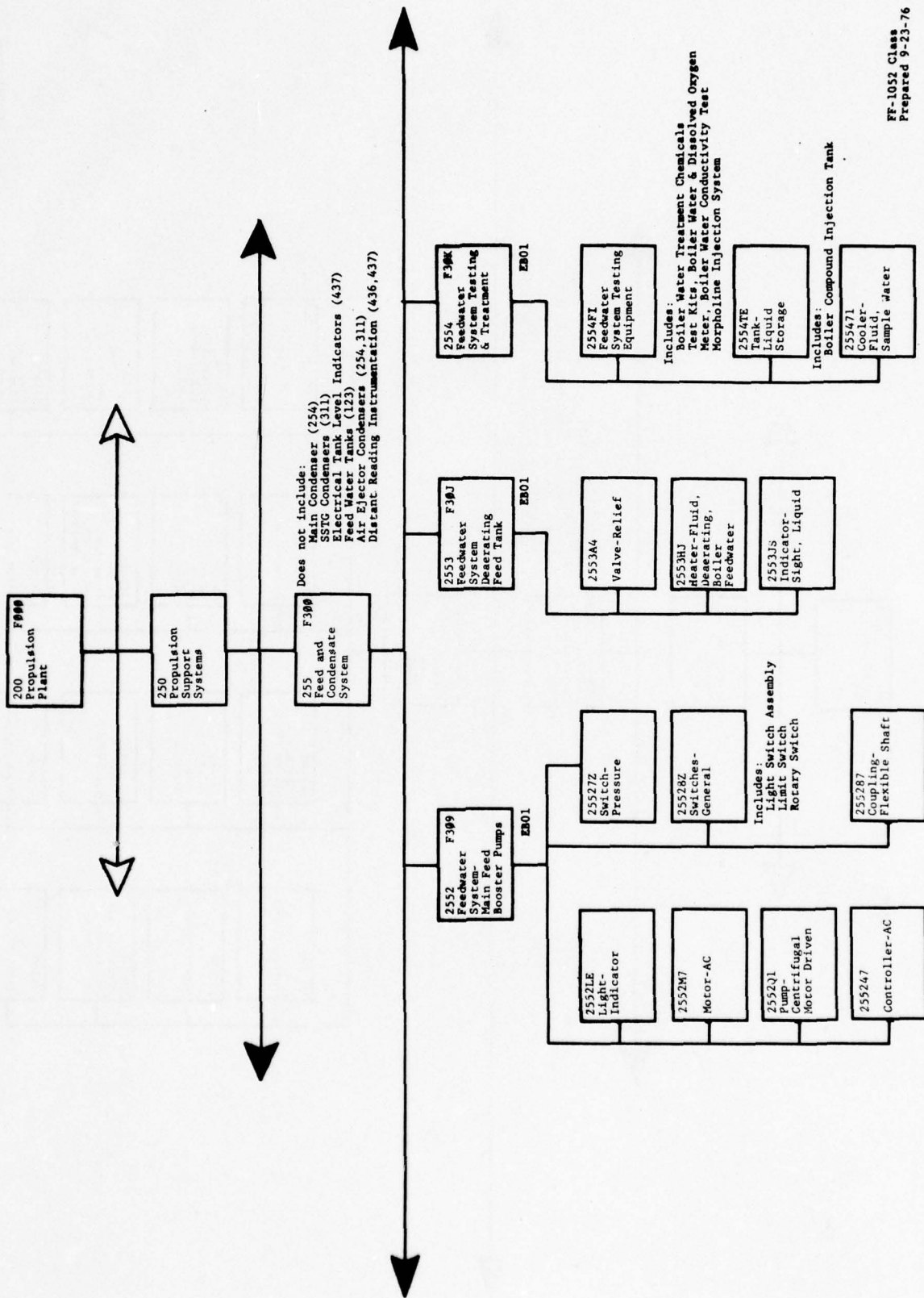

FF-1052 Class  
Prepared 9-23-76

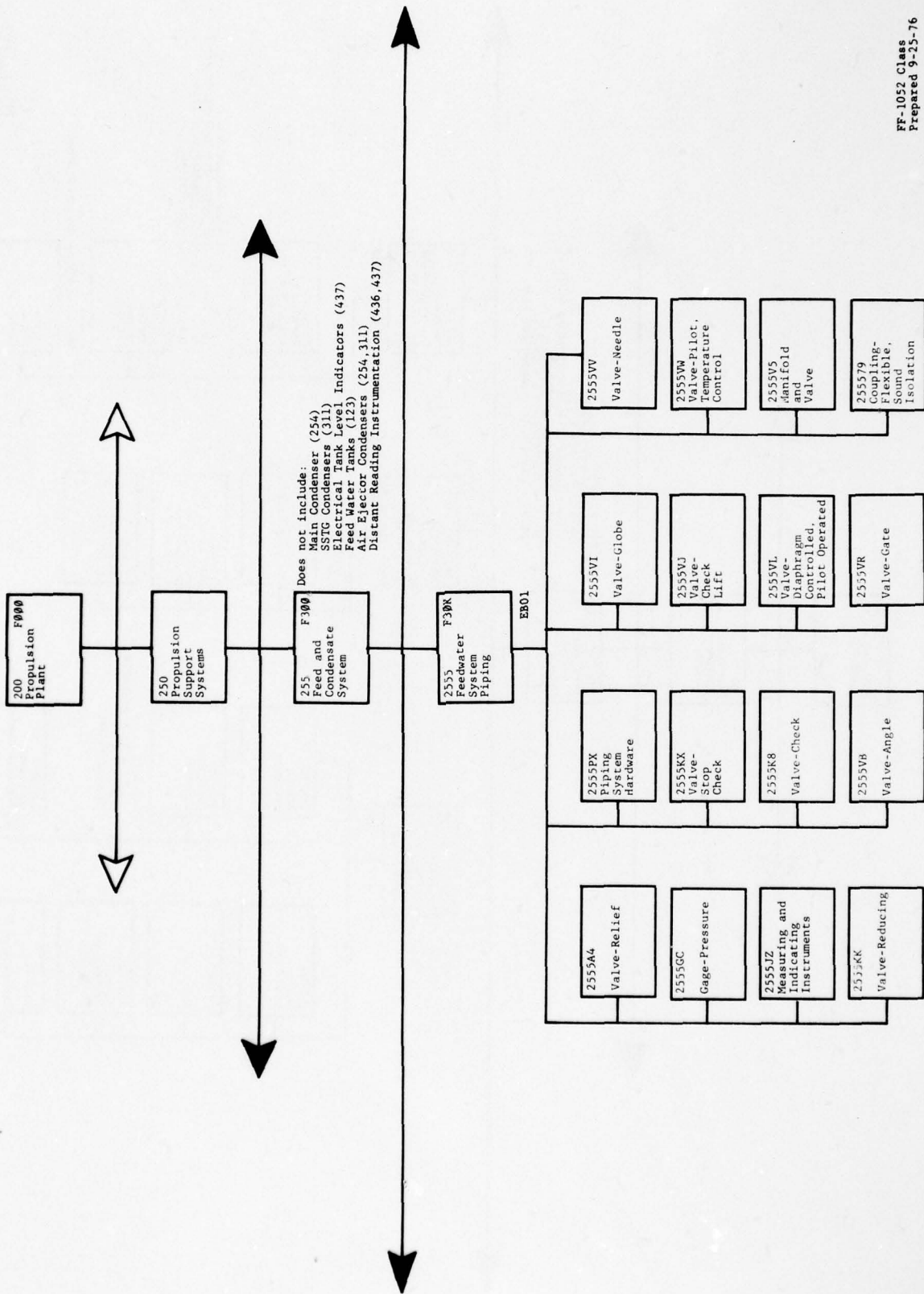

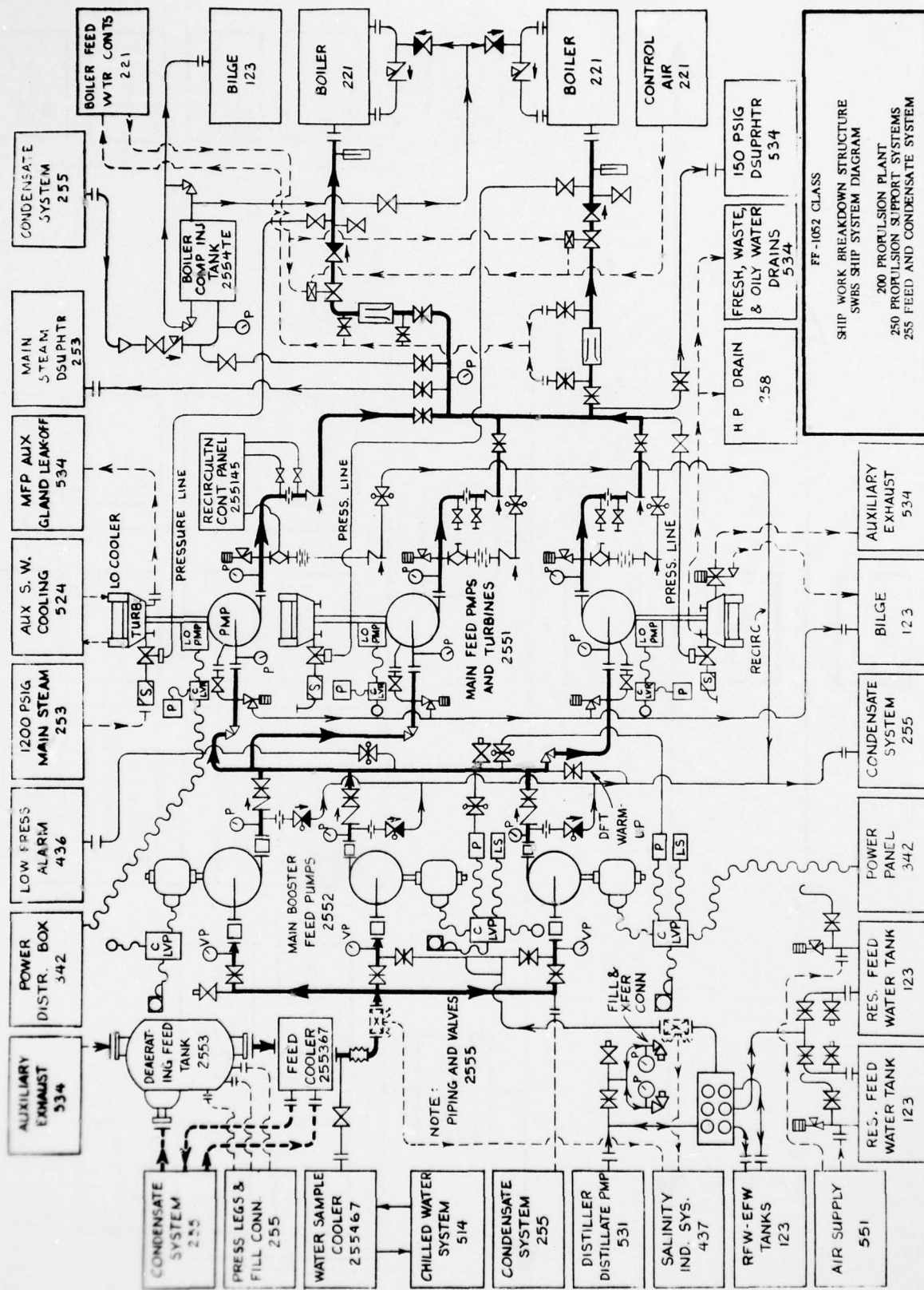

FF-1052 CLASS  
 SHIP WORK BREAKDOWN DIAGRAM  
 SWBS SHIP SYSTEM DIAGRAM  
 200 PROPULSION PLANT  
 250 PROPULSION SUPPORT SYSTEMS  
 255 FEED AND CONDENSATE SYSTEM

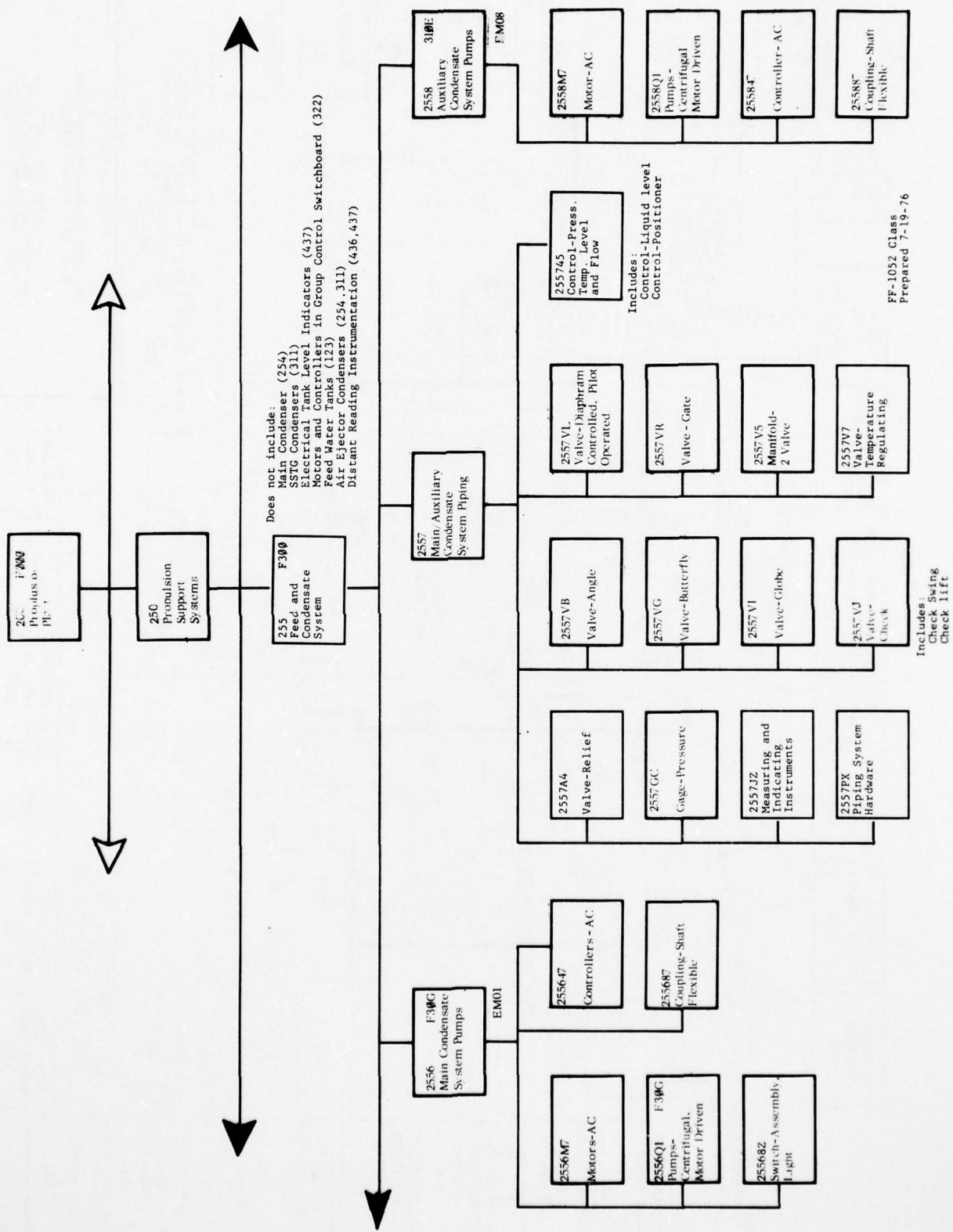

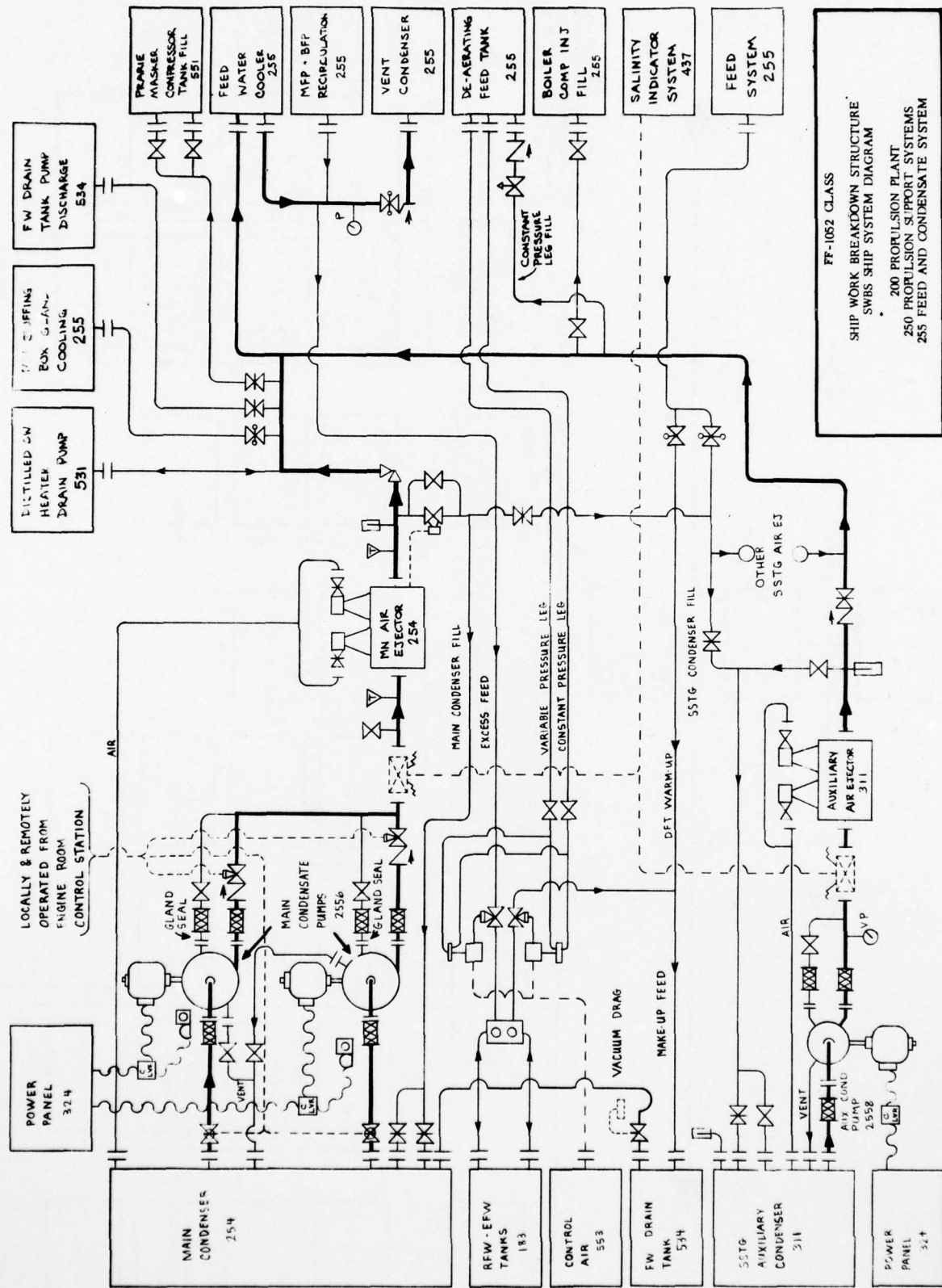

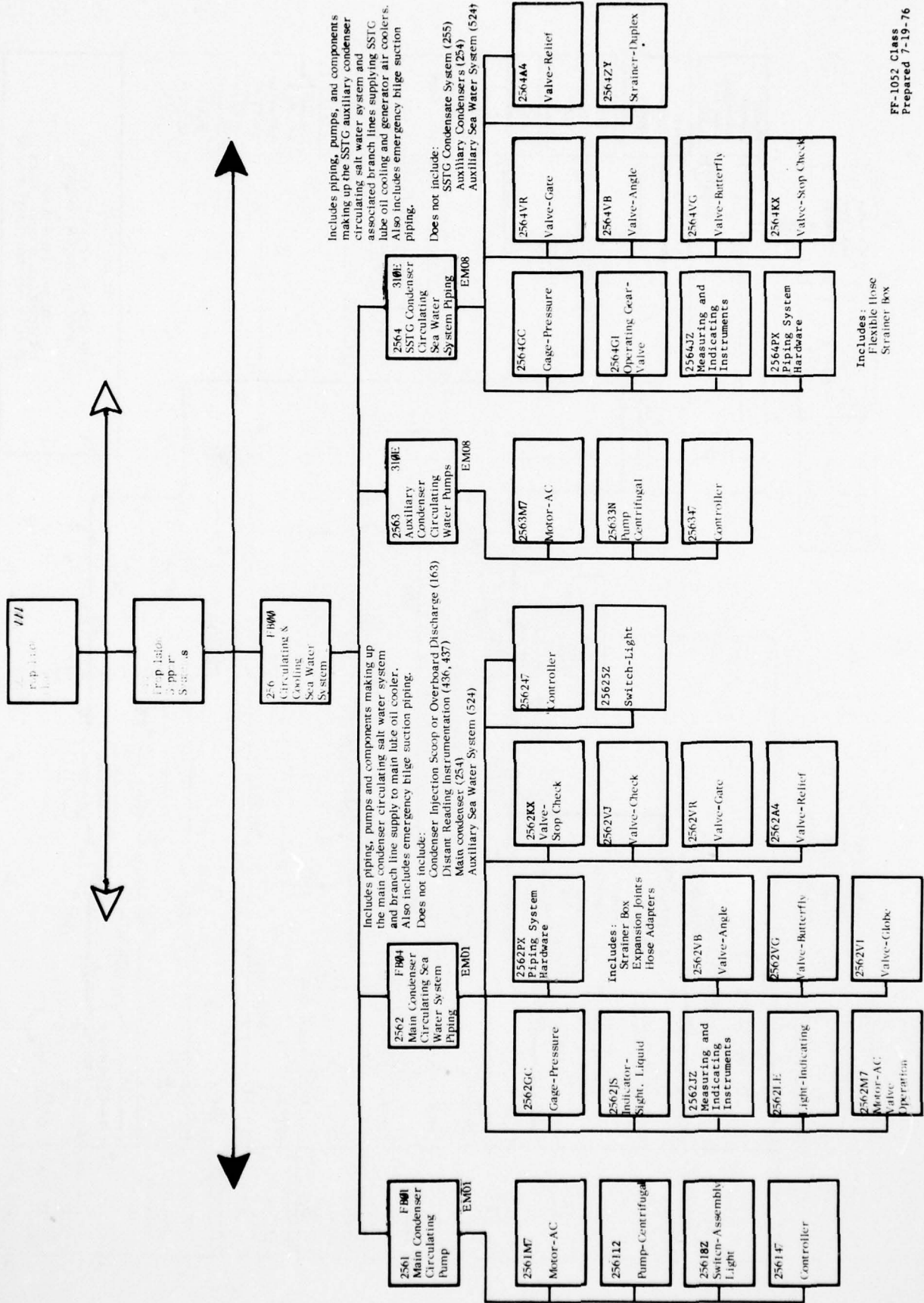

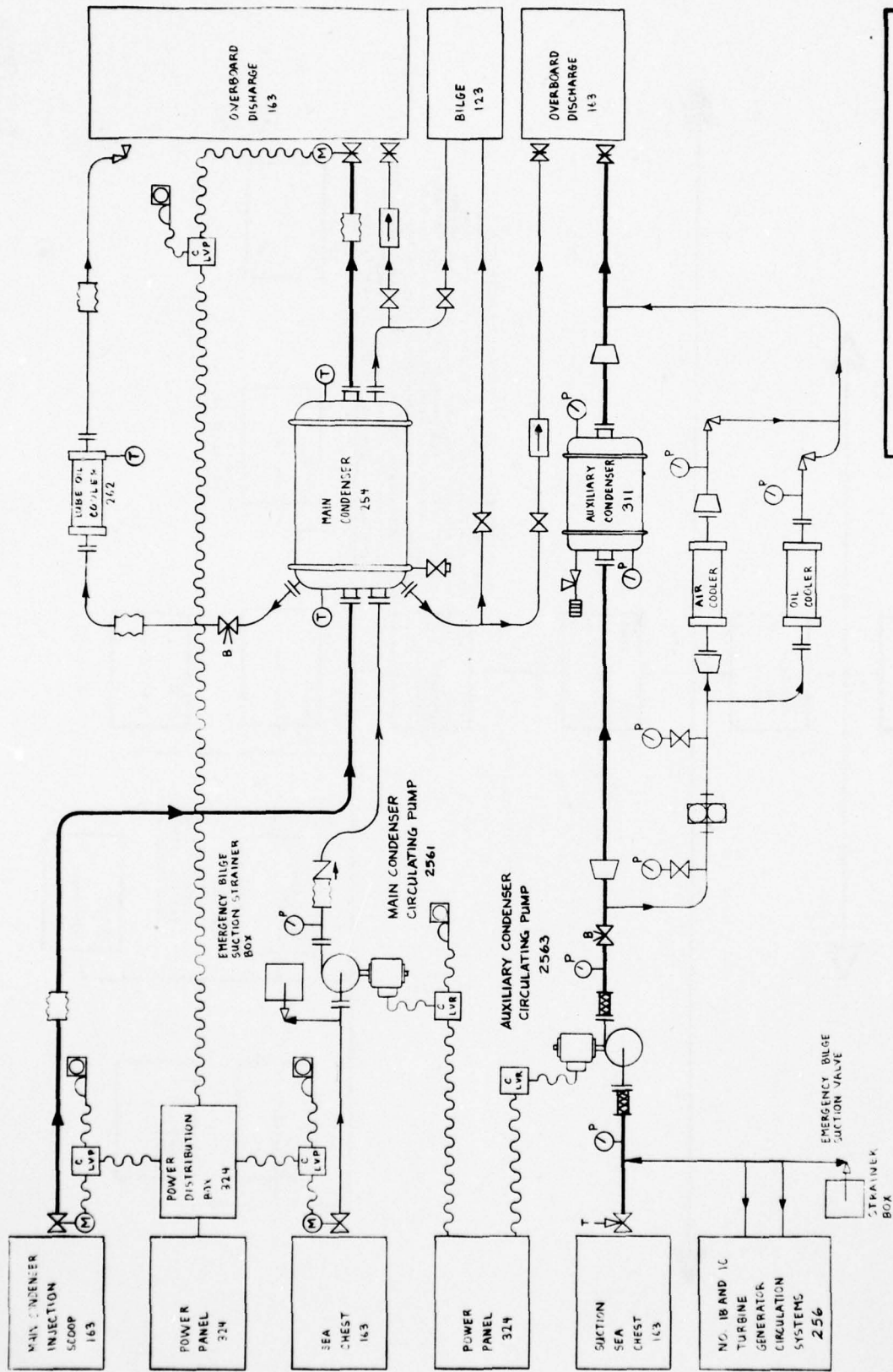

FF-1052 CLASS  
 SHIP WORK BREAKDOWN STRUCTURE  
 SWBS SHIP SYSTEM DIAGRAM  
 200 PROPULSION PLANT  
 250 PROPULSION SUPPORT SYSTEMS  
 256 CIRCULATING AND COOLING WATER SEA SYSTEMS

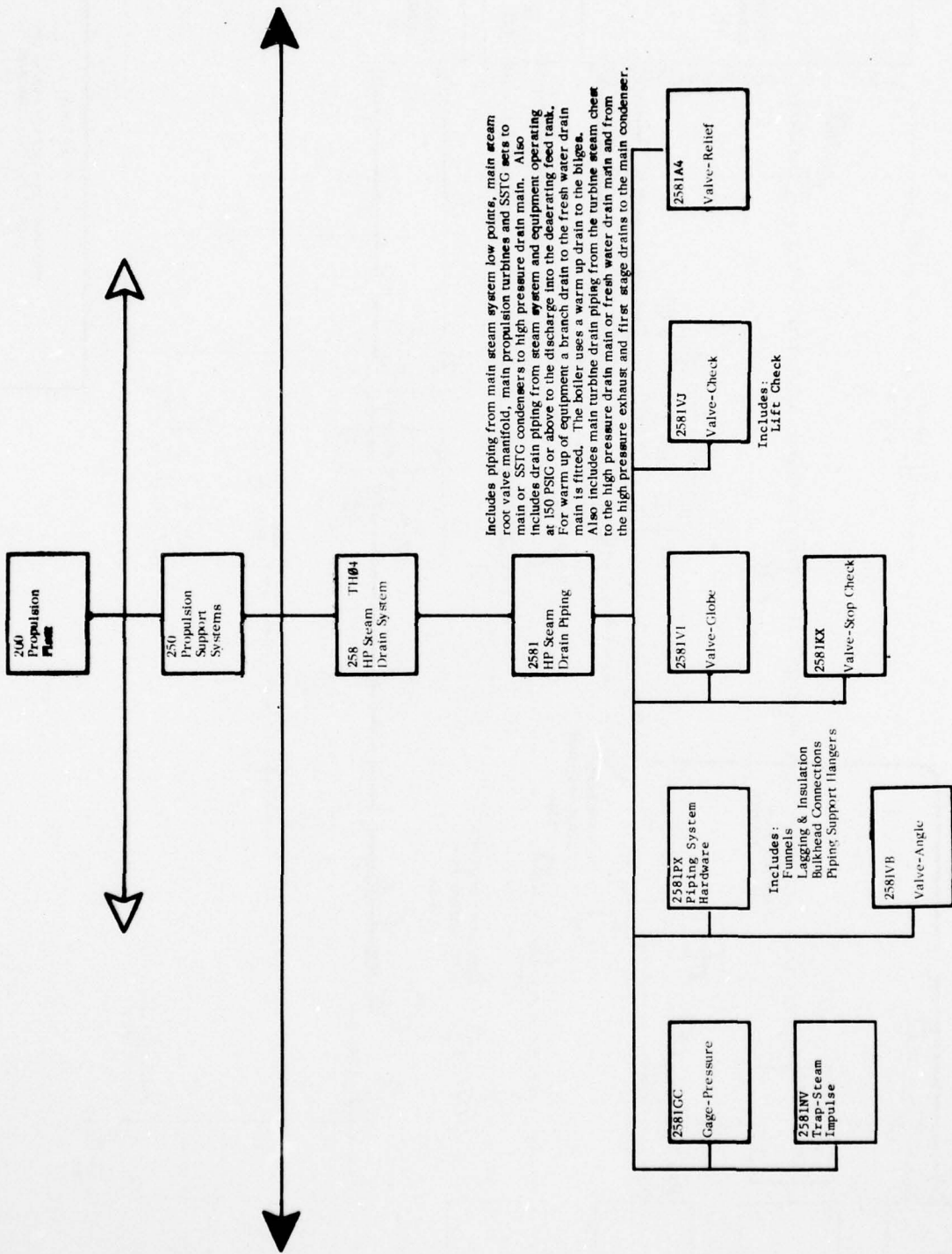

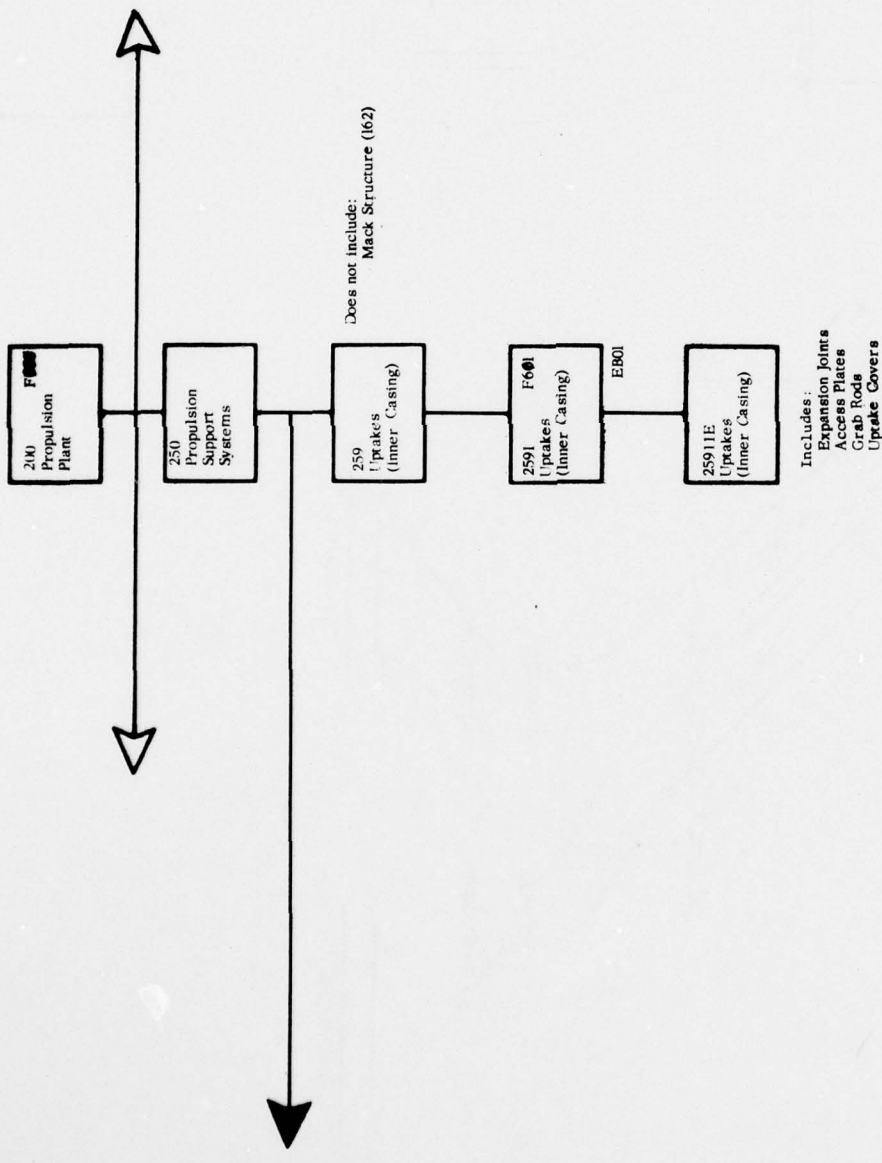

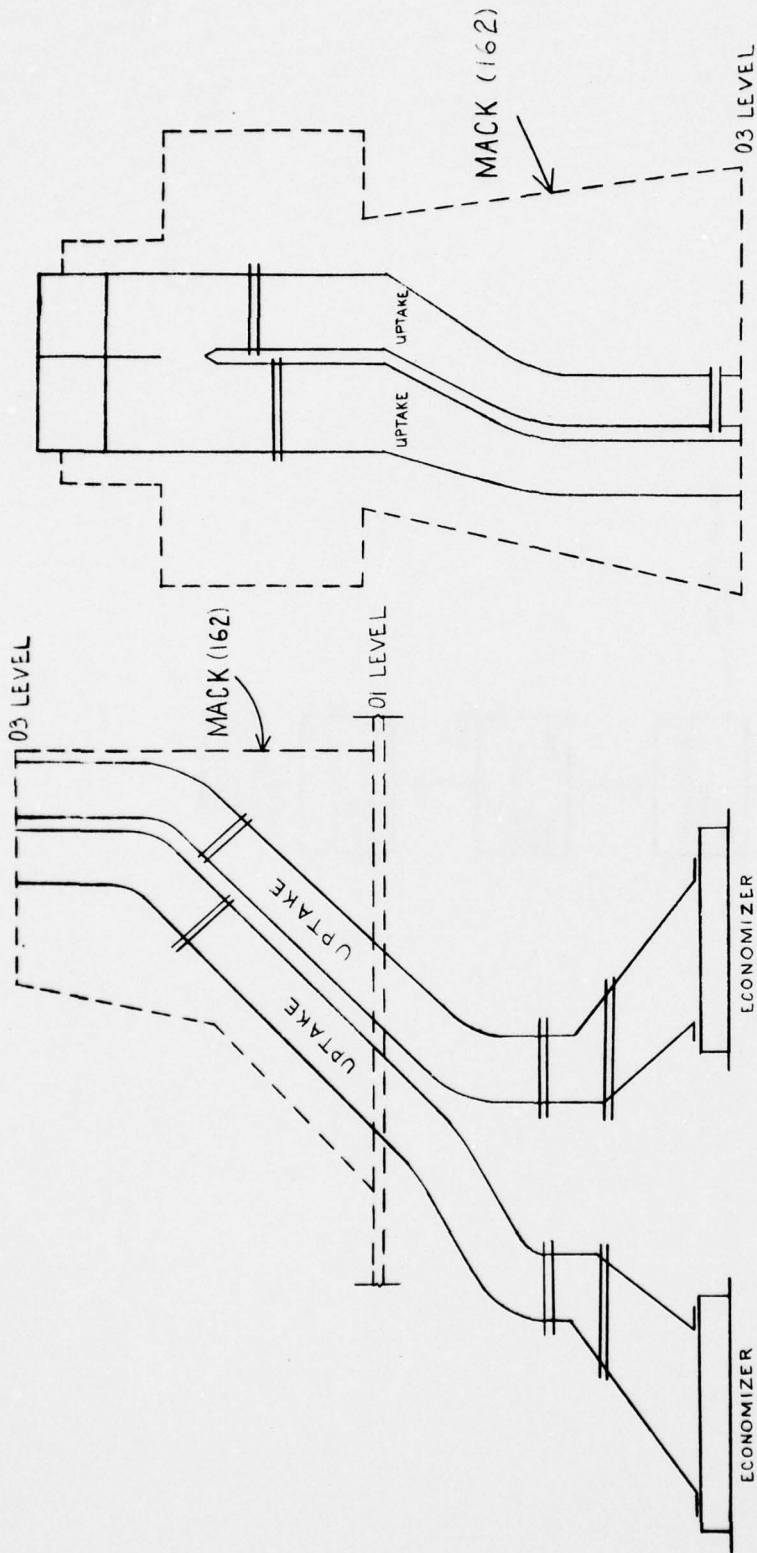

259 UPTAKES

FF-1052 CLASS  
 SHIP WORK BREAKDOWN STRUCTURE  
 SWBS SHIP SYSTEM DIAGRAM  
 200 PROPULSION PLANT  
 250 PROPULSION SUPPORT SYSTEMS  
 259 UPTAKES (INNER CASING)

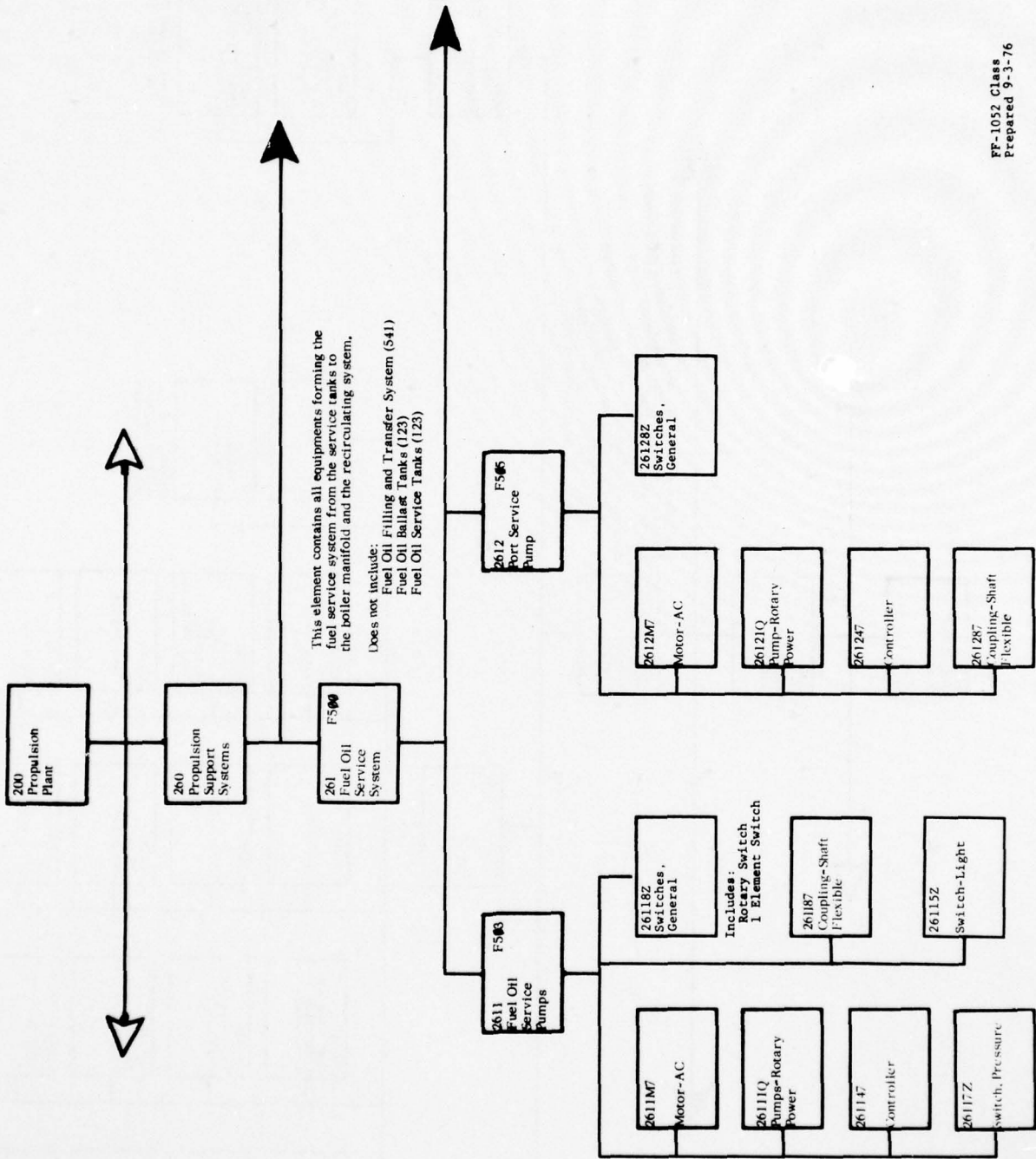

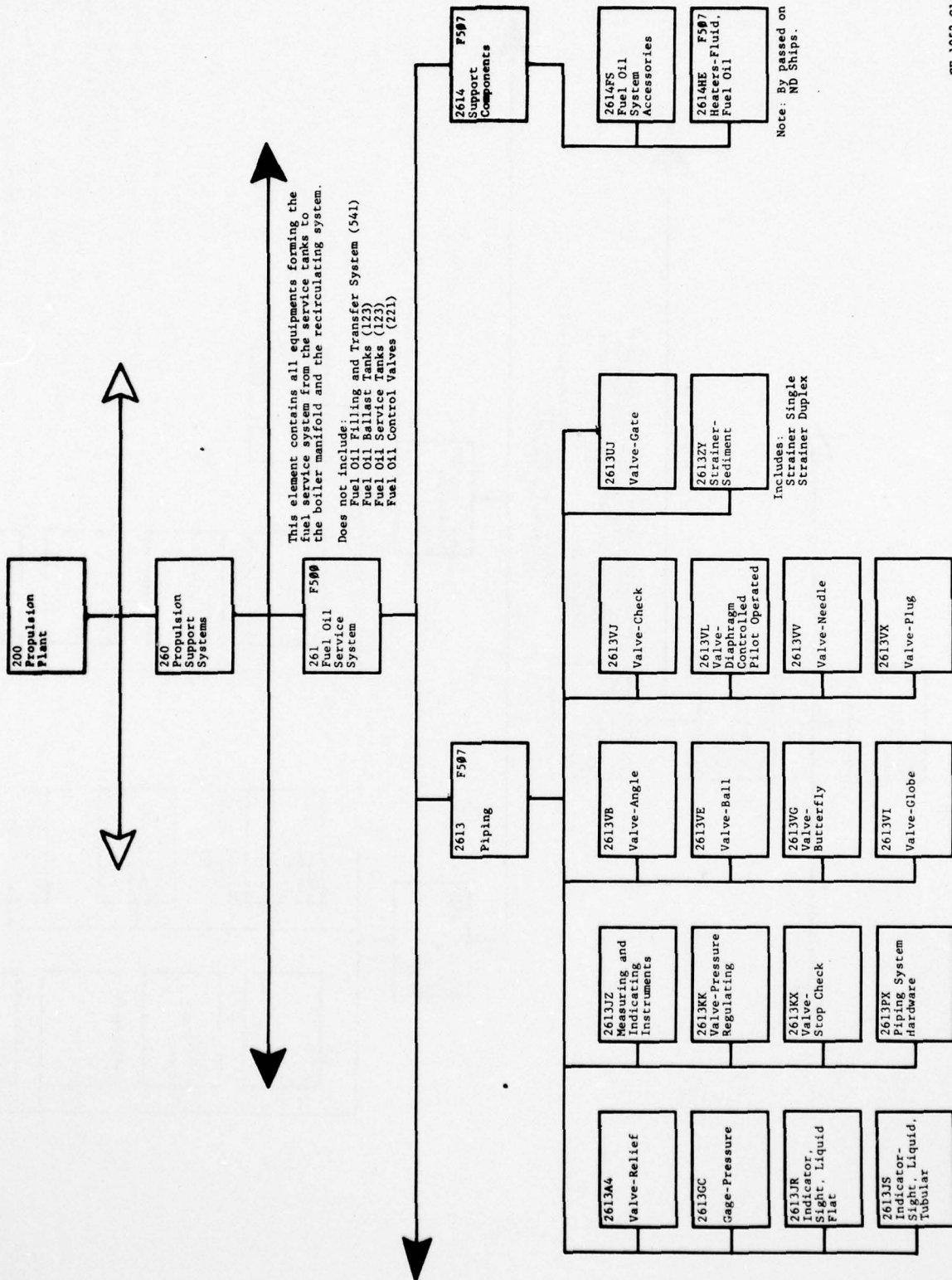

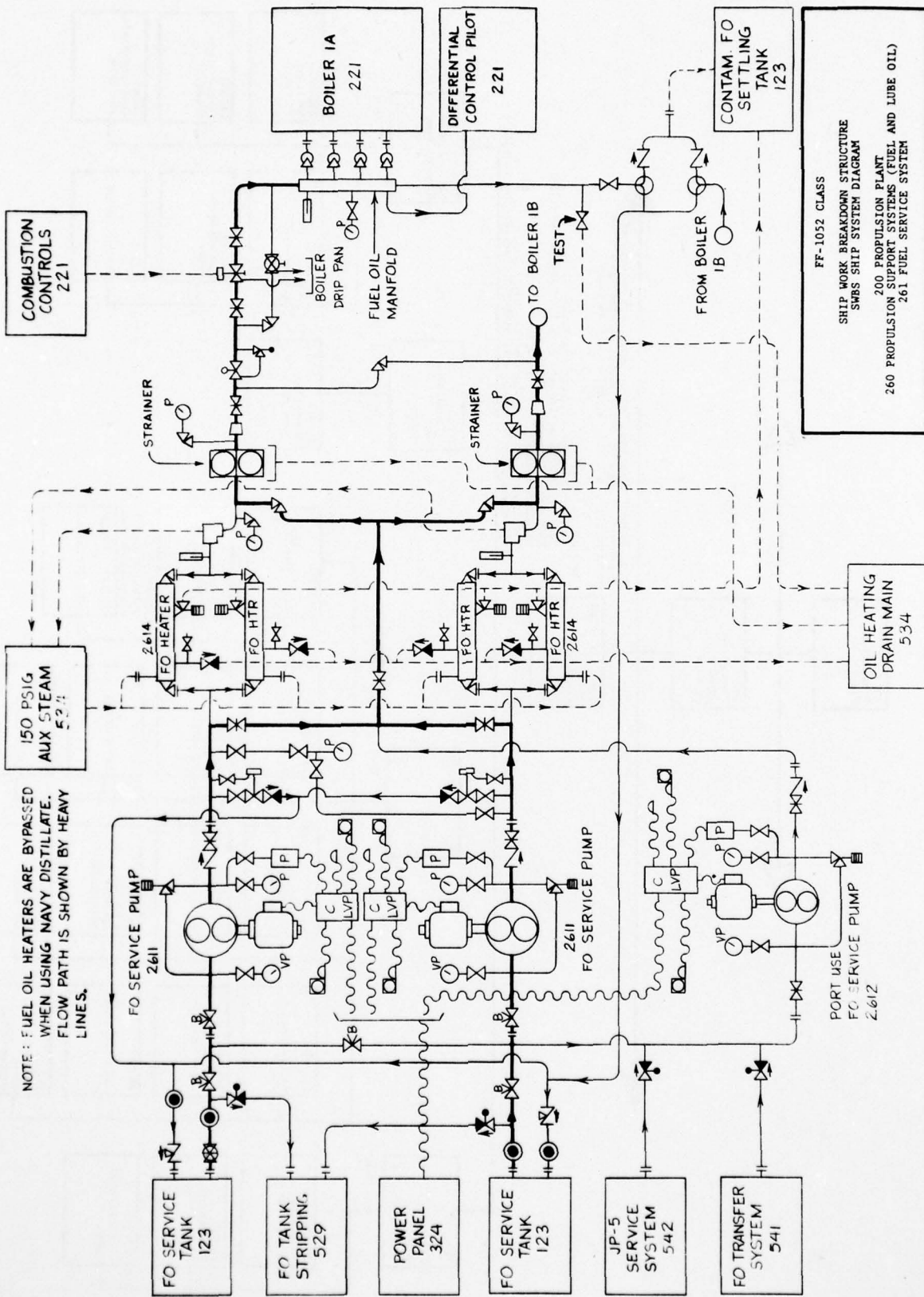

NOTE: FUEL OIL HEATERS ARE BYPASSED WHEN USING NAVY DISTILLATE. FLOW PATH IS SHOWN BY HEAVY LINES.

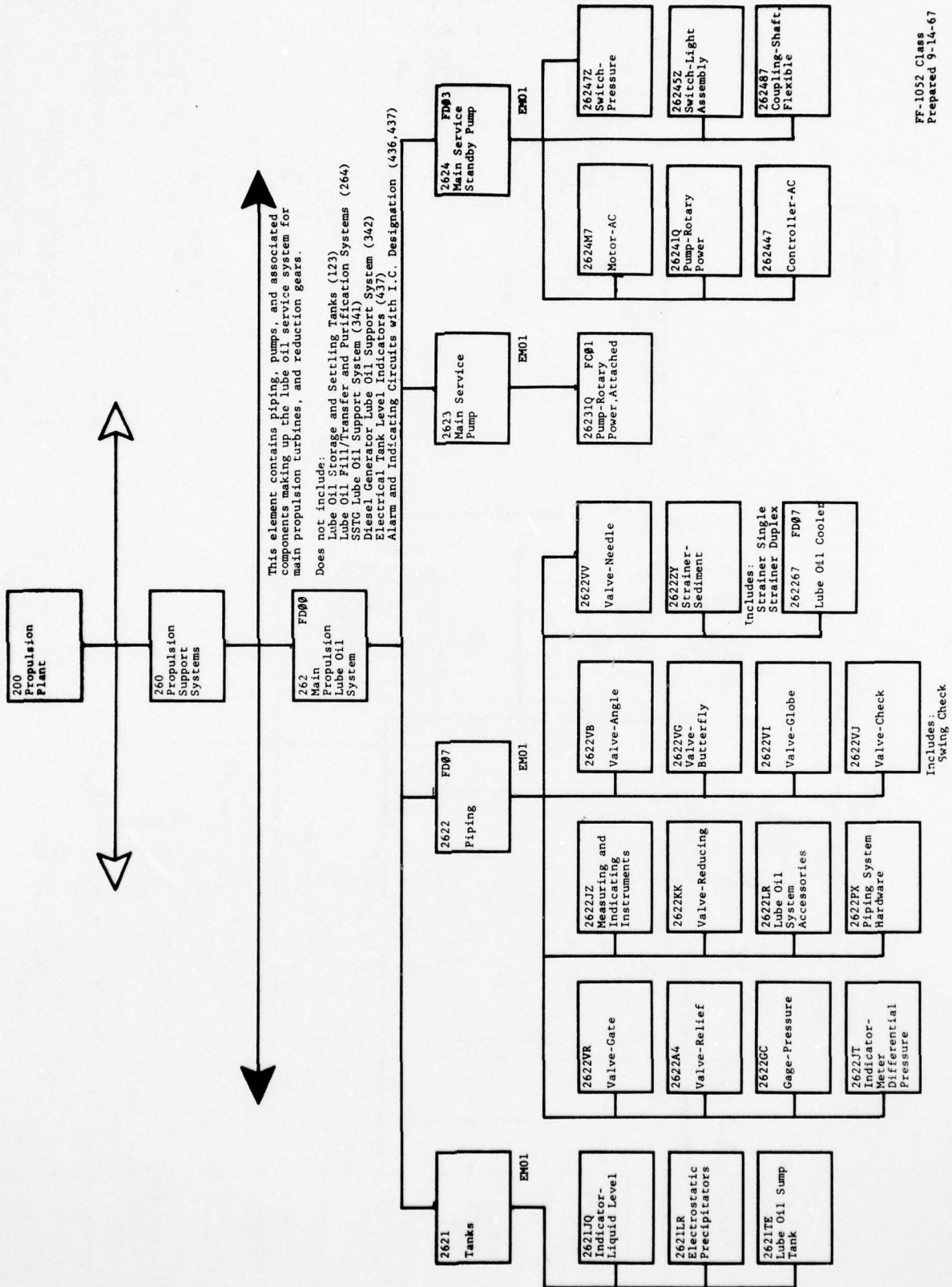

FF-1052 Class  
 Prepared 9-14-67

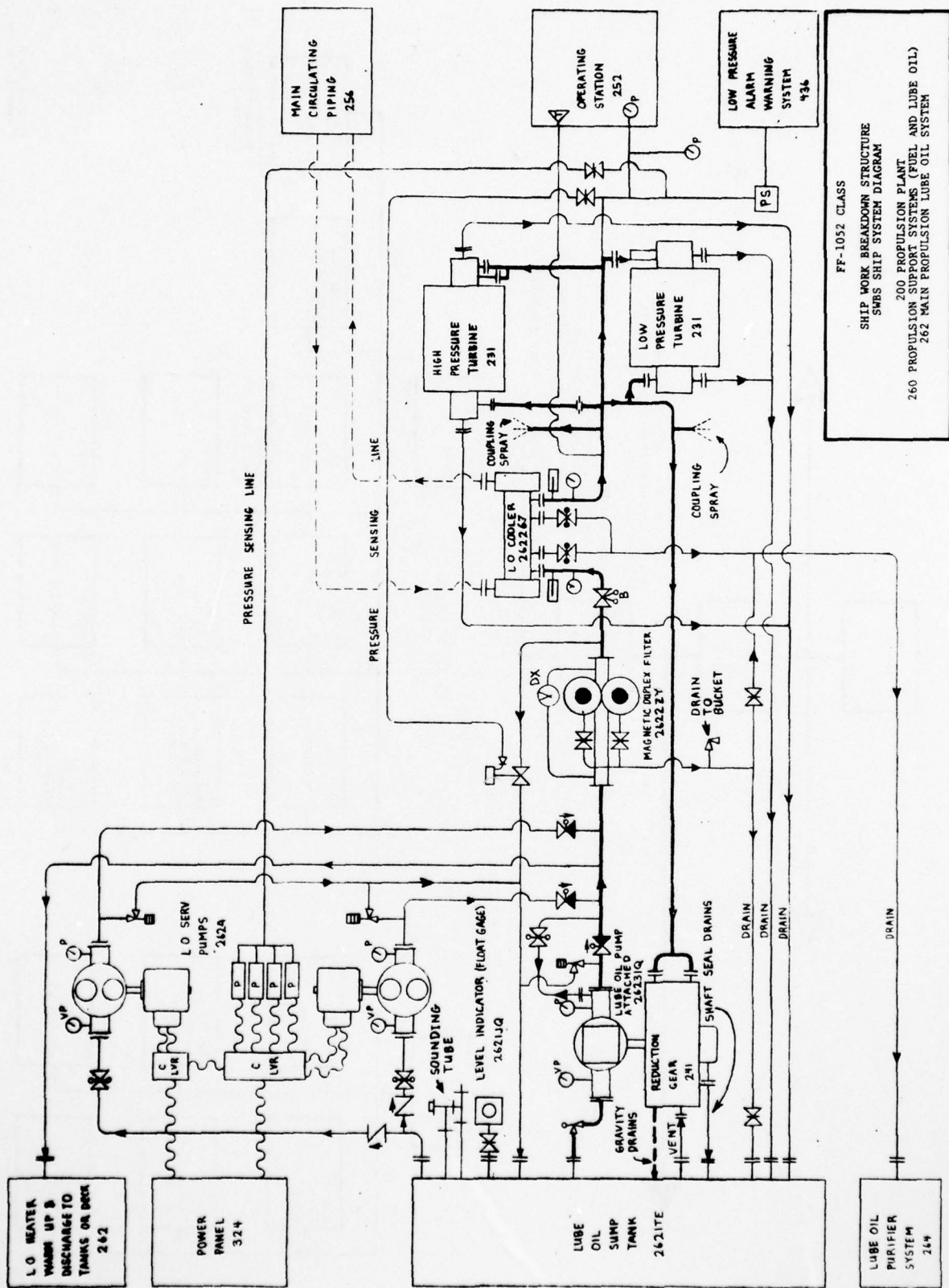

FF-1052 CLASS  
 SHIP WORK BREAKDOWN STRUCTURE  
 SMBS SHIP SYSTEM DIAGRAM  
 200 PROPULSION PLANT  
 260 PROPULSION SUPPORT SYSTEMS (FUEL AND LUBE OIL)  
 262 MAIN PROPULSION LUBE OIL SYSTEM

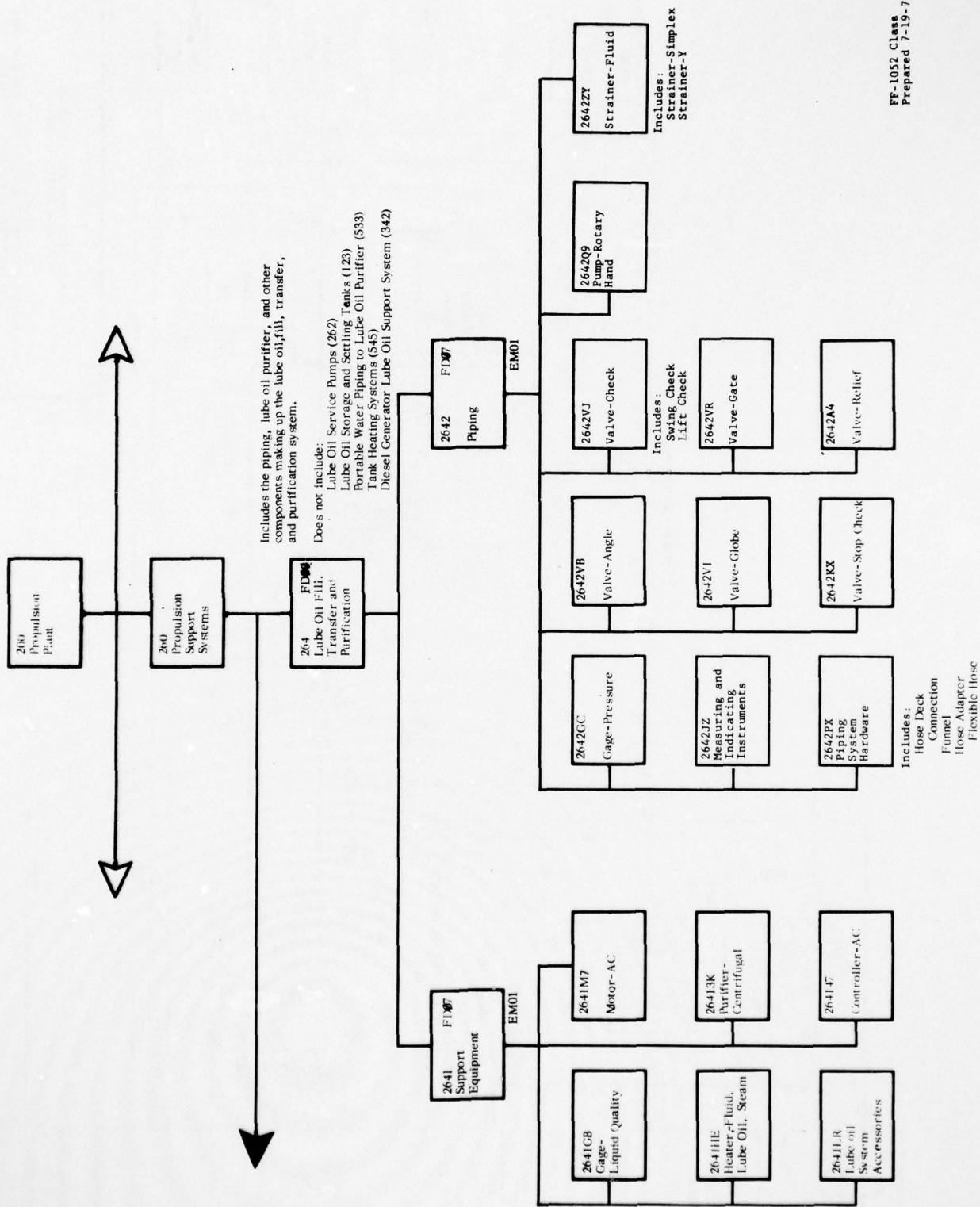

AD-A052 469

ARINC RESEARCH CORP ANNAPOLIS MD  
SHIP SYSTEMS DEFINITION AND INDEX (SWBS STAGING DIAGRAMS) FOR F--ETC(U)  
OCT 76

N00140-76-D-0813

F/G 13/10

NL

UNCLASSIFIED

1804-01-1-1547

2 of 3  
ADA  
062 469

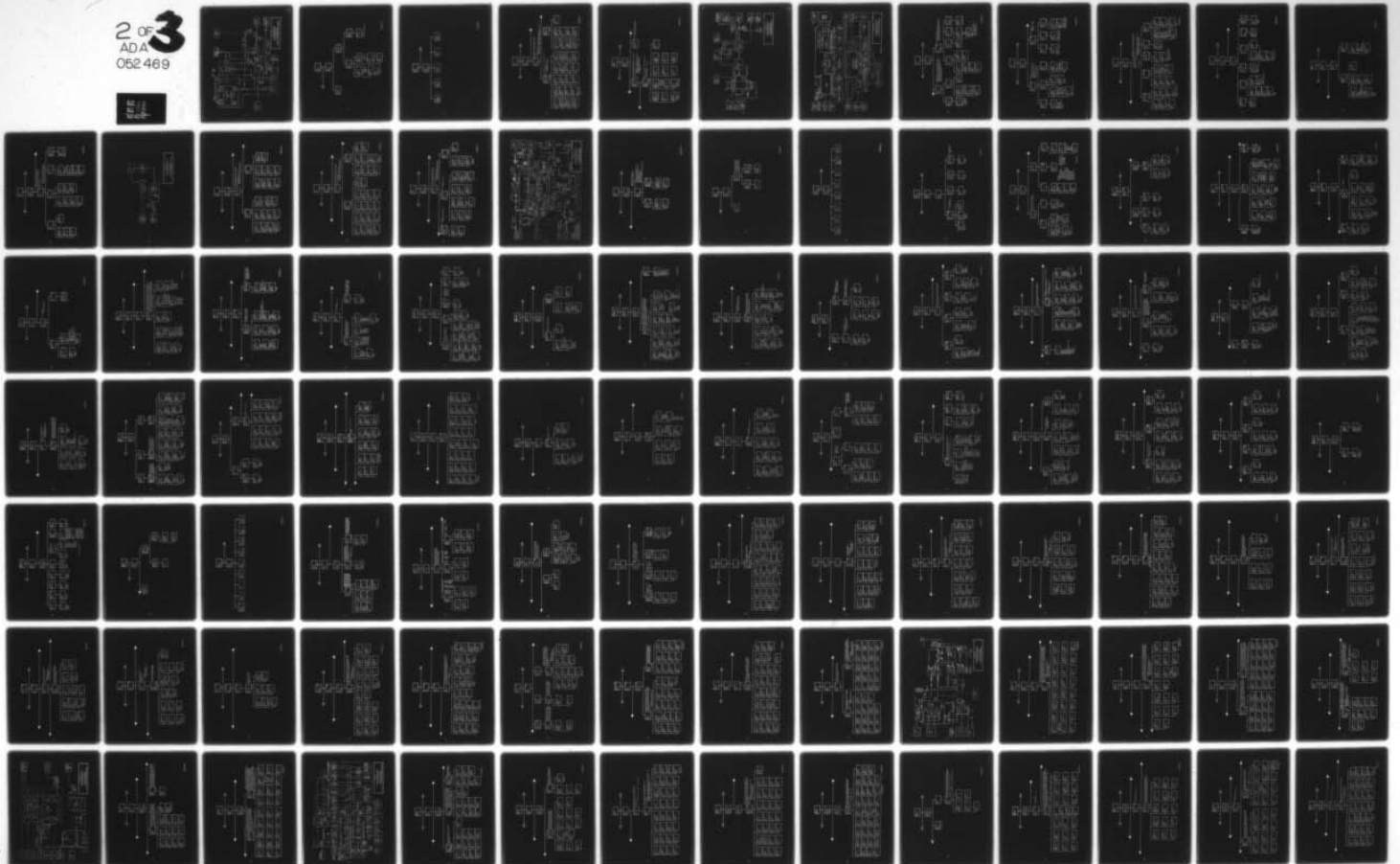

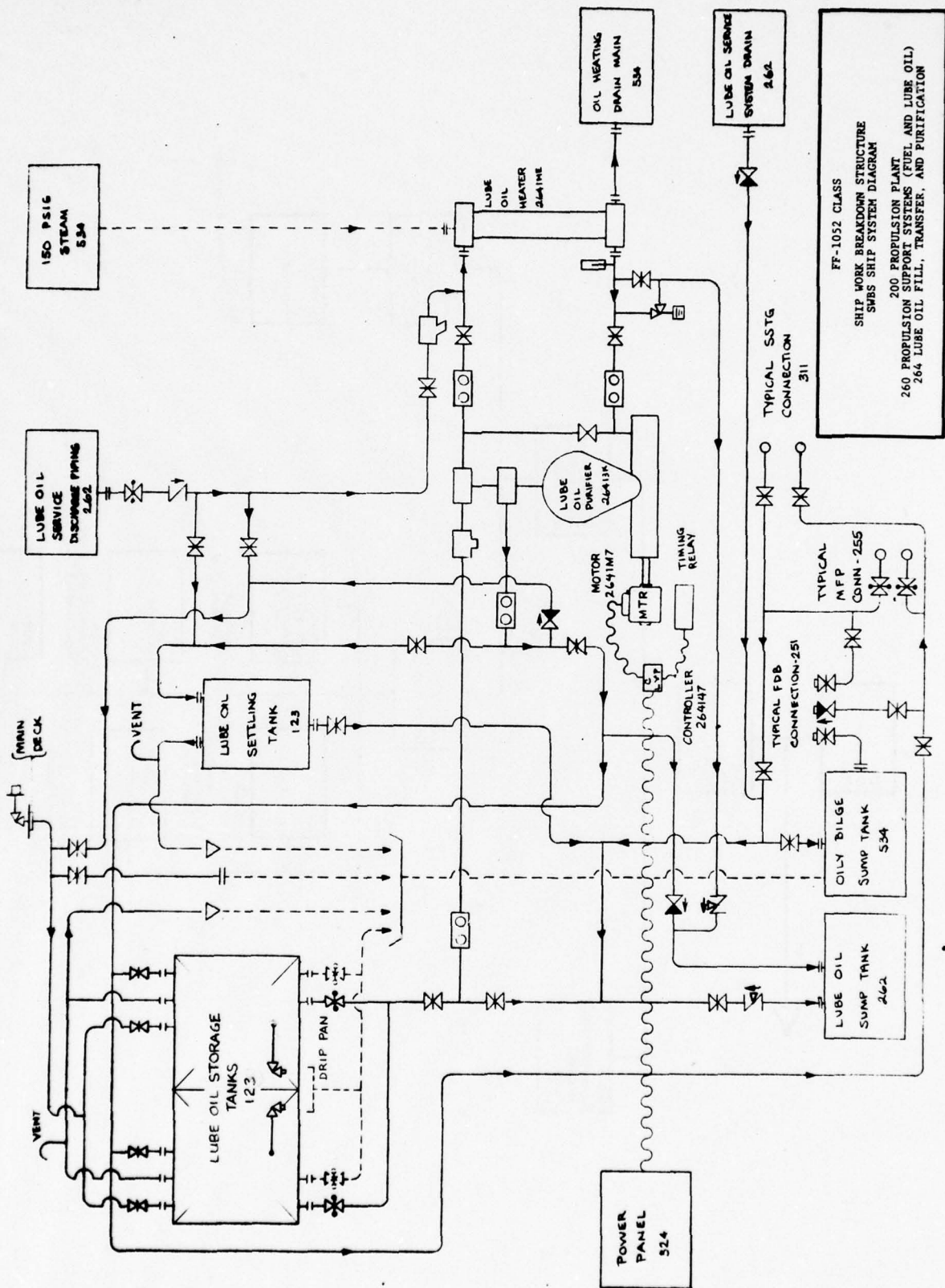

FF-1052 CLASS  
 SHIP WORK BREAKDOWN STRUCTURE  
 SHBS SHIP SYSTEM DIAGRAM  
 200 PROPULSION PLANT  
 260 PROPULSION SUPPORT SYSTEMS (FUEL AND LUBE OIL)  
 264 LUBE OIL FILL, TRANSFER, AND PURIFICATION

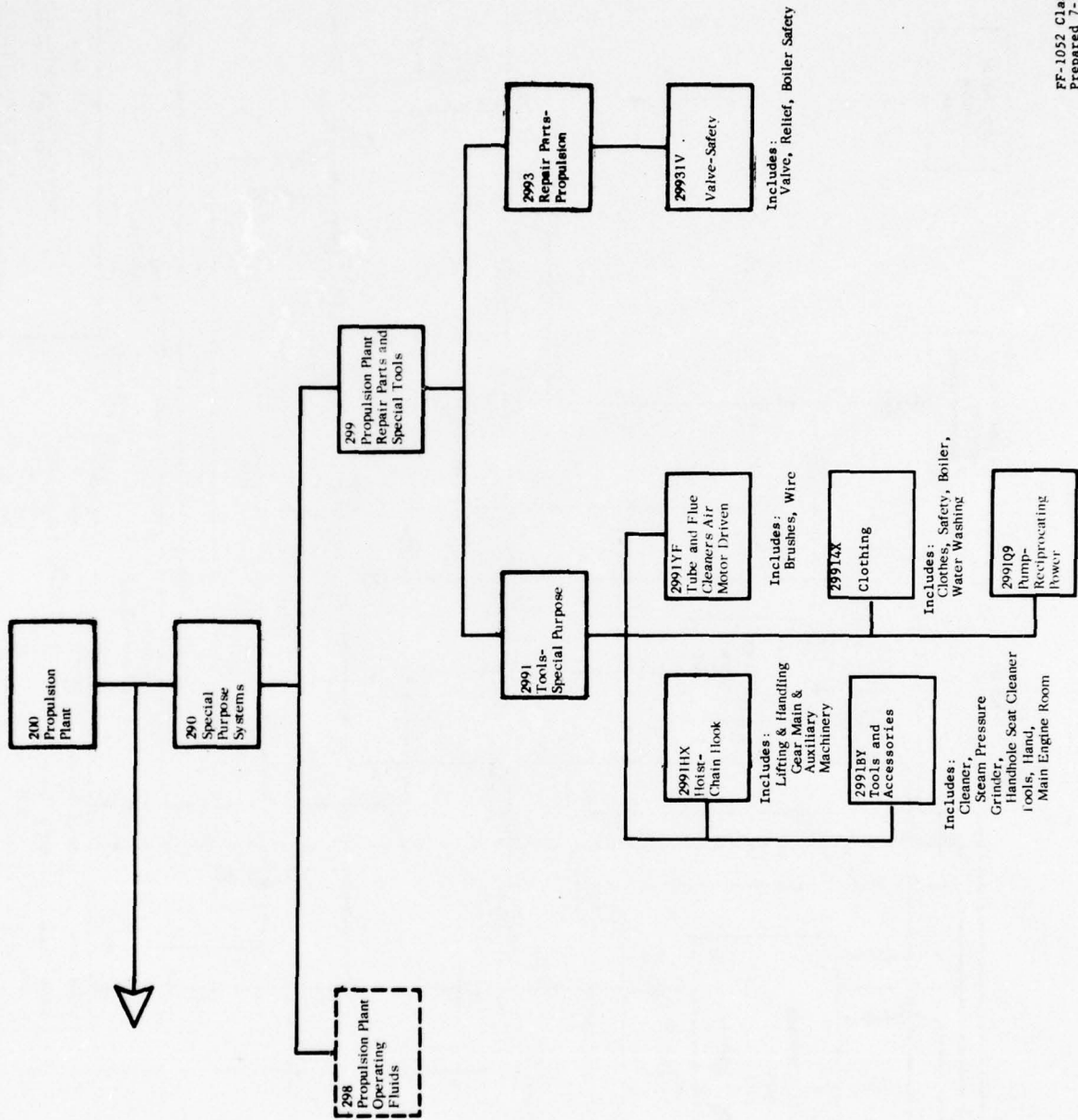

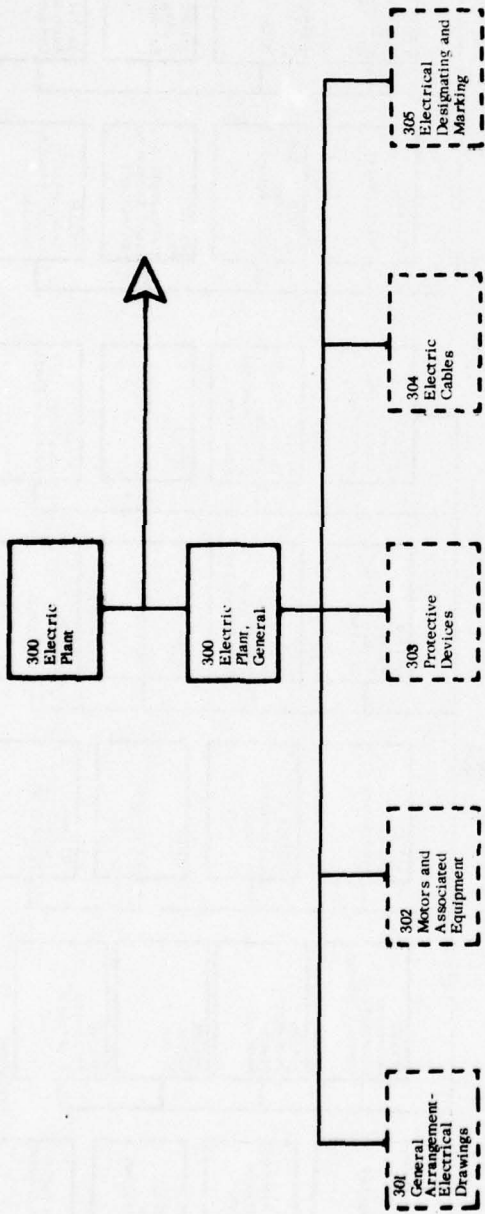



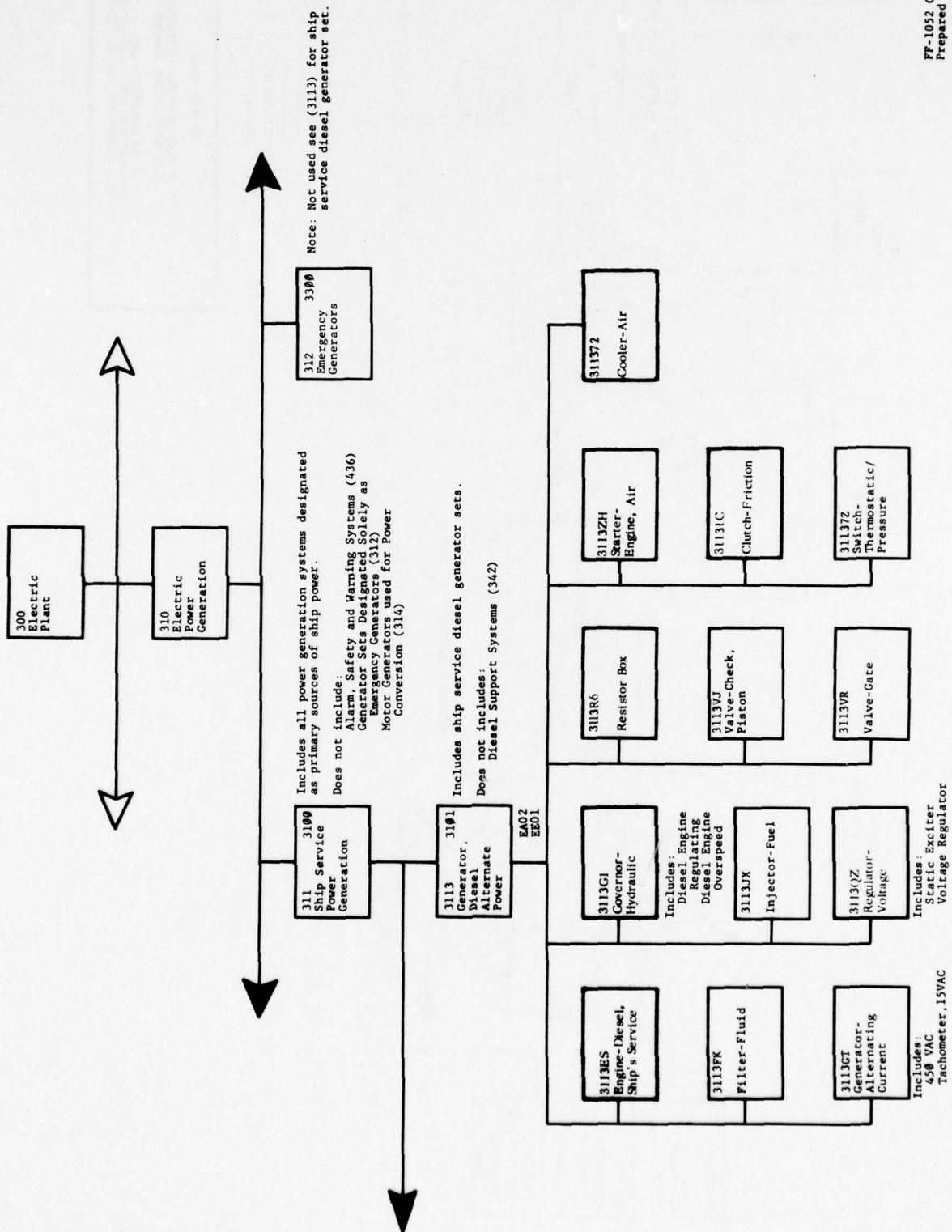

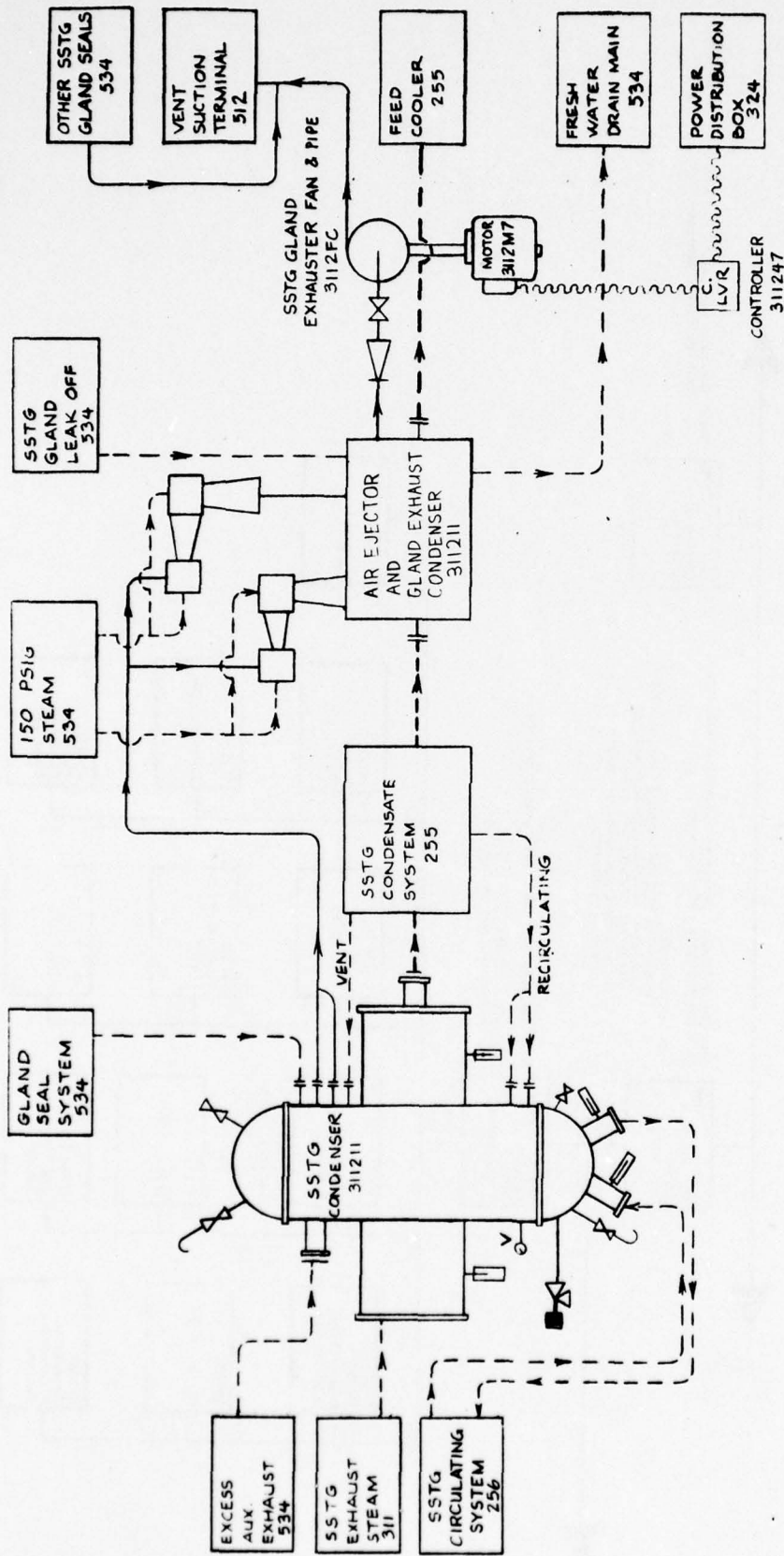

FF-1052 CLASS  
 SHIP WORK BREAKDOWN STRUCTURE  
 SMS SHIP SYSTEM DIAGRAM  
 300 ELECTRIC PLANT  
 310 ELECTRIC POWER GENERATION  
 311 SSTS CONDENSERS AND AIR EJECTORS

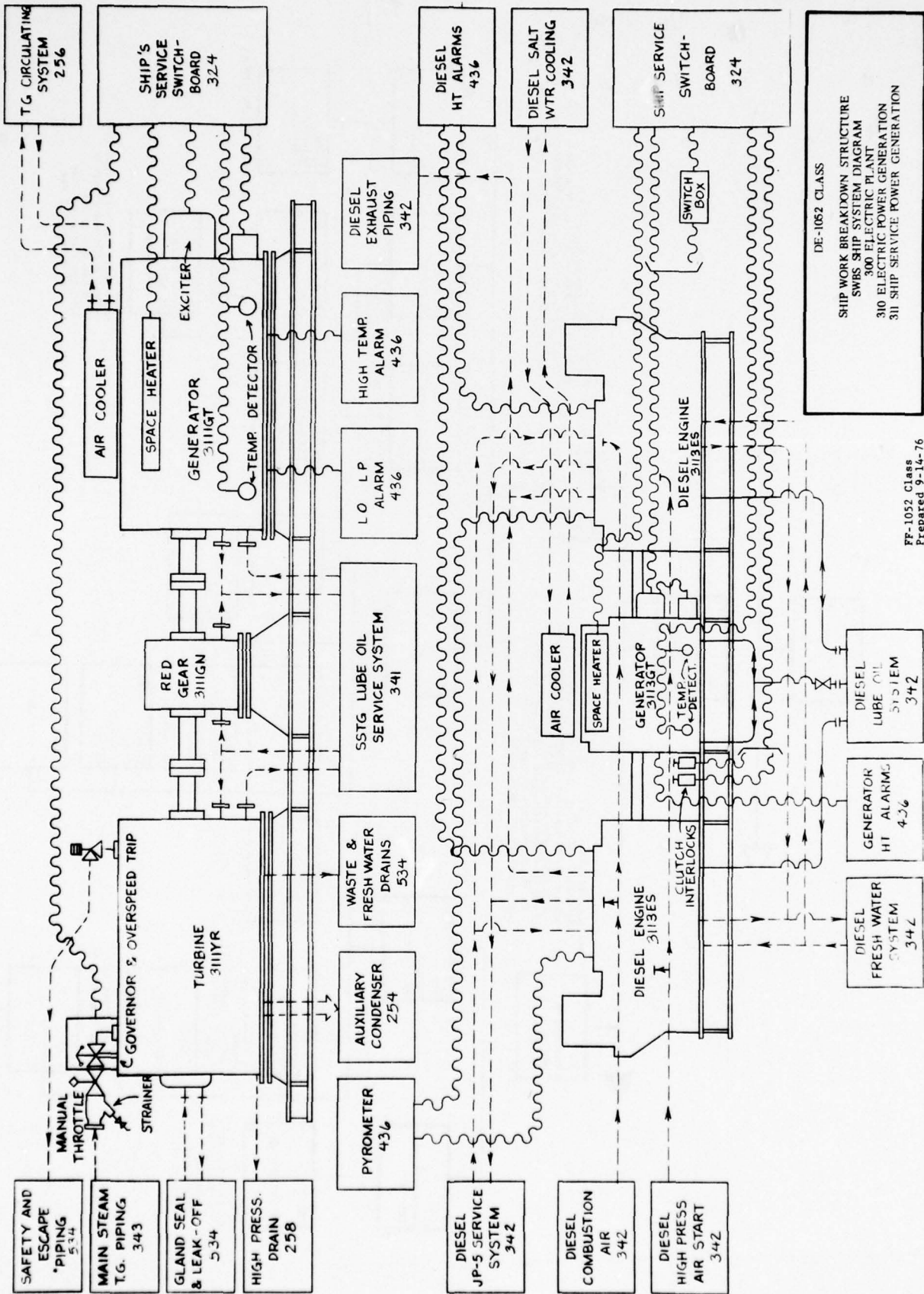

DE-1052 CLASS  
 SHIP WORK BREAKDOWN STRUCTURE  
 SWBS SHIP SYSTEM DIAGRAM  
 300 ELECTRIC PLANT  
 310 ELECTRIC POWER GENERATION  
 311 SHIP SERVICE POWER GENERATION

FF-1052 Class  
 Prepared 9-14-76

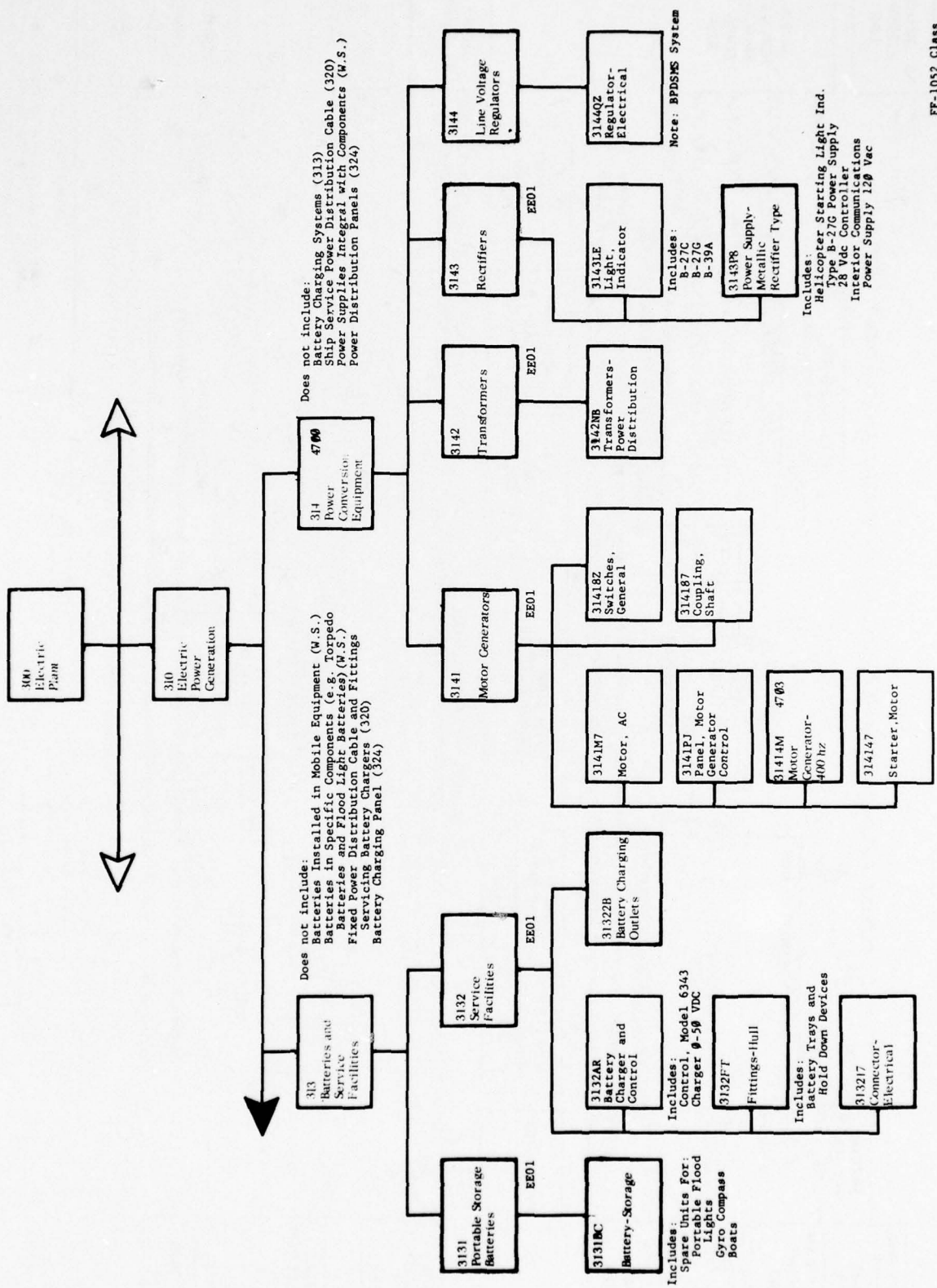

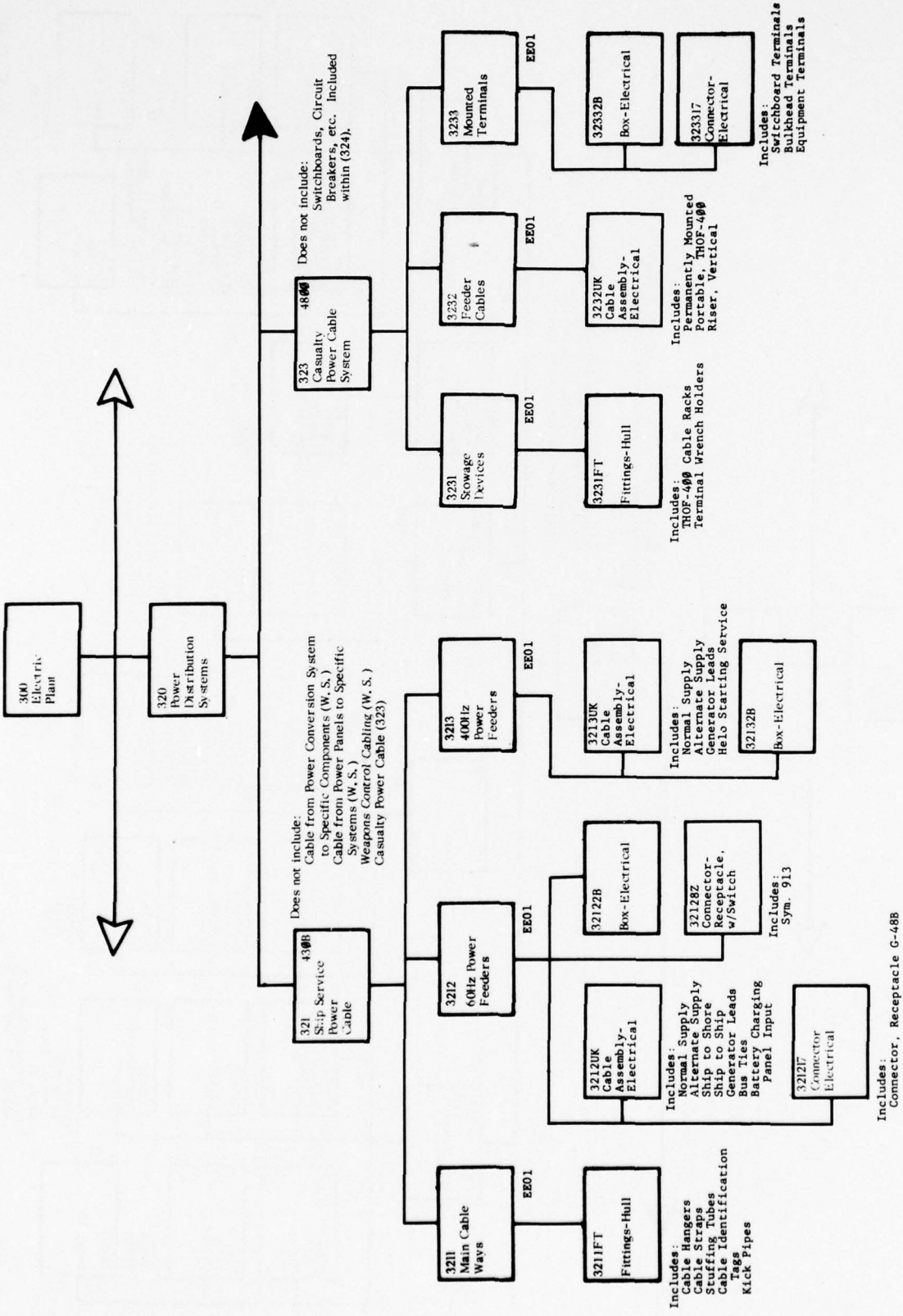

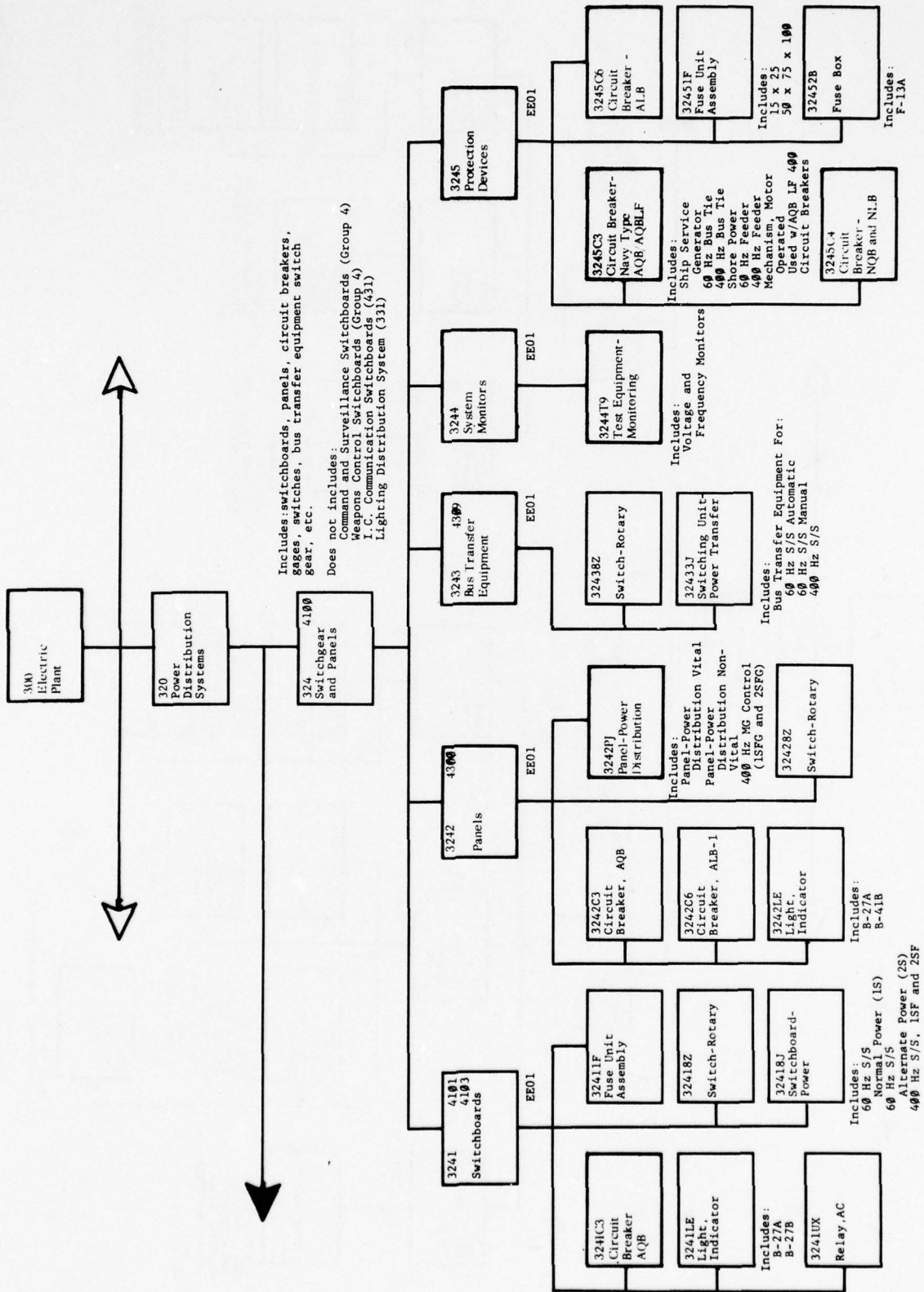

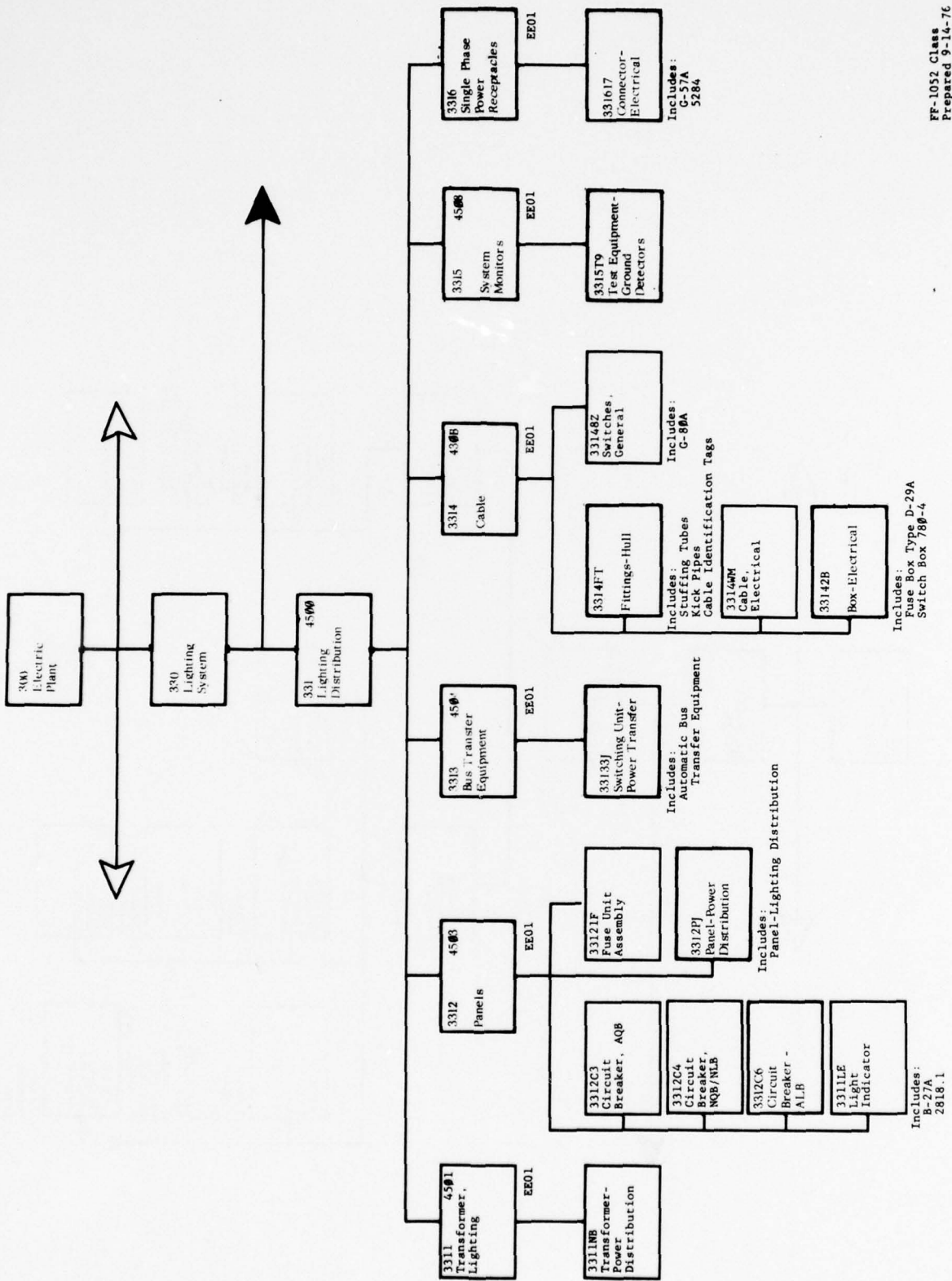

FF-1052 Class  
Prepared 9-14-76

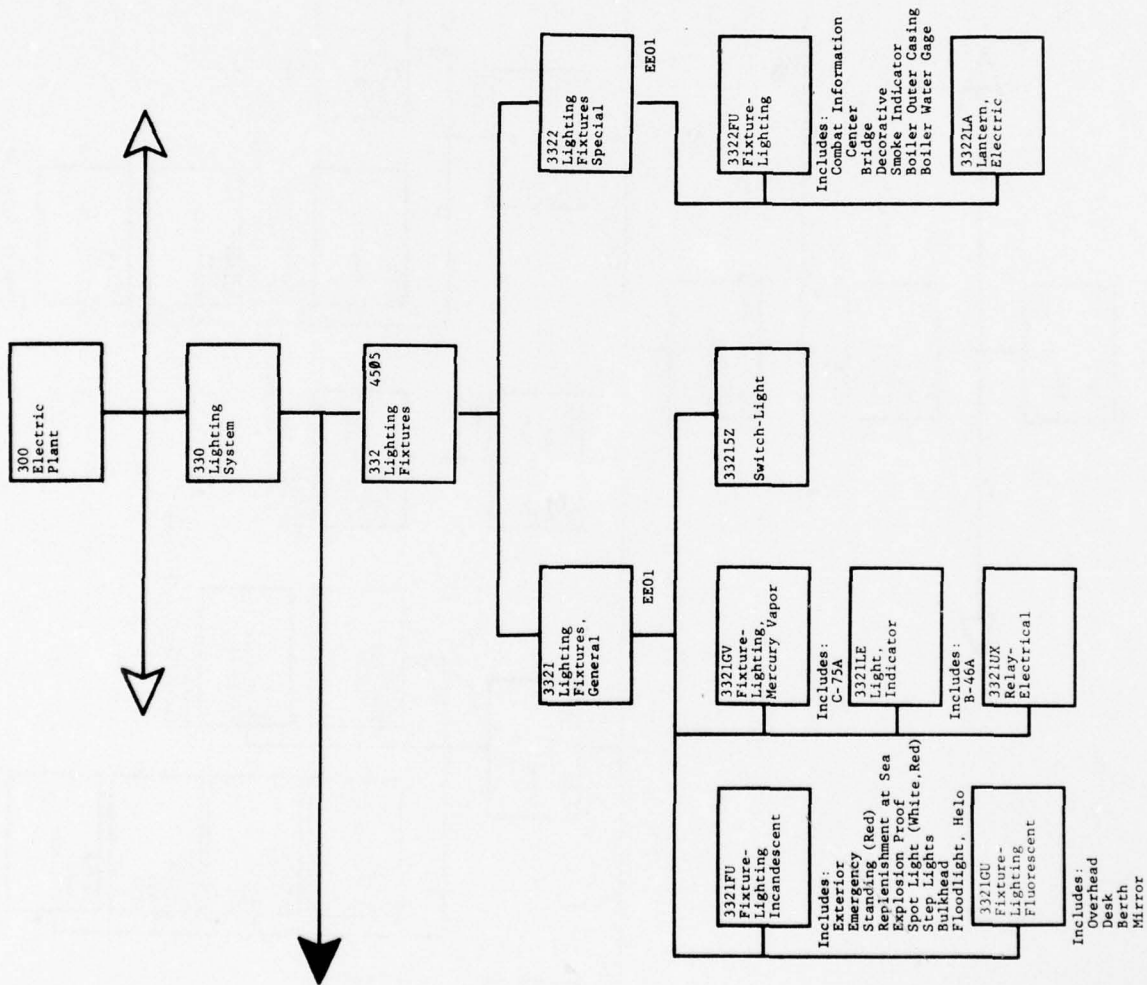

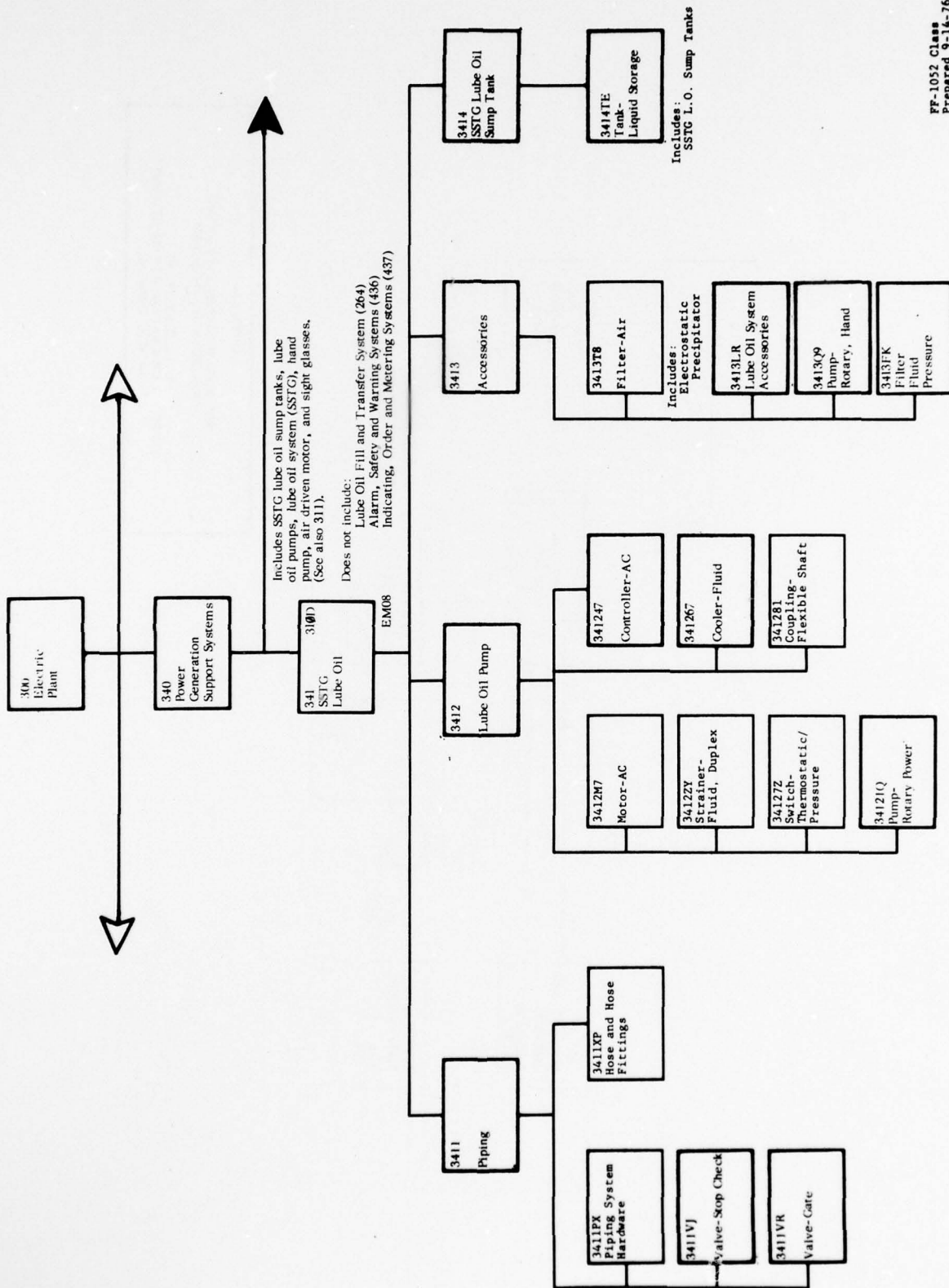

FF-1052 Class  
Prepared 9-14-76

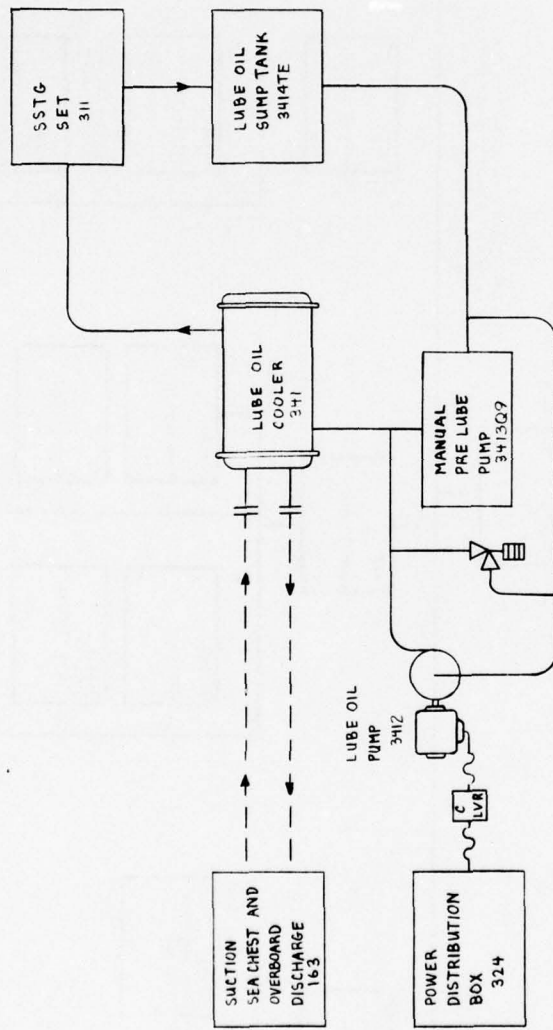

DE-1052 CLASS  
 SHIP WORK BREAKDOWN STRUCTURE  
 SWBS SHIP SYSTEM DIAGRAM  
 300 ELECTRIC PLANT  
 340 POWER GENERATION SUPPORT SYSTEMS  
 341 SSTG LUBE OIL

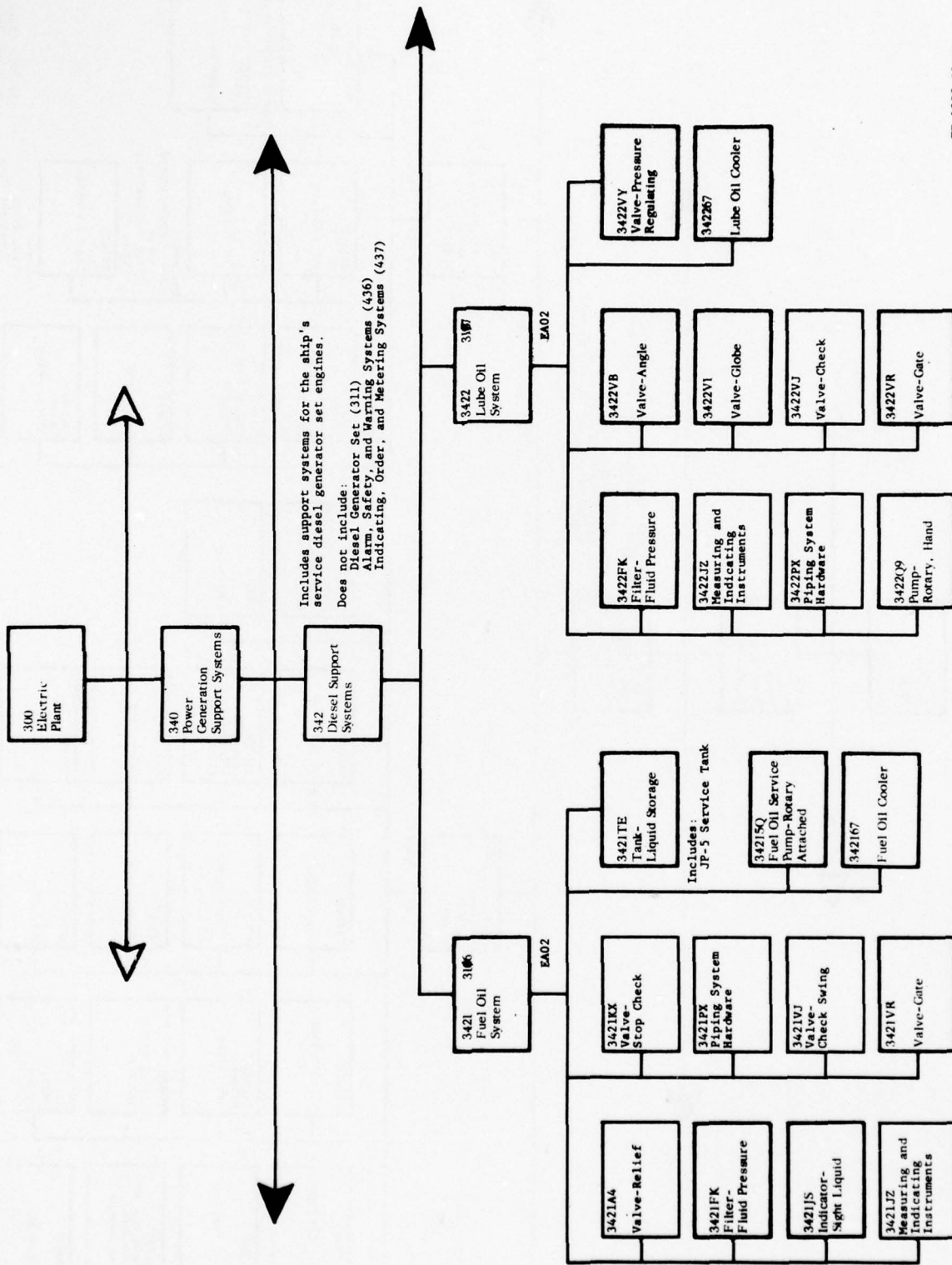

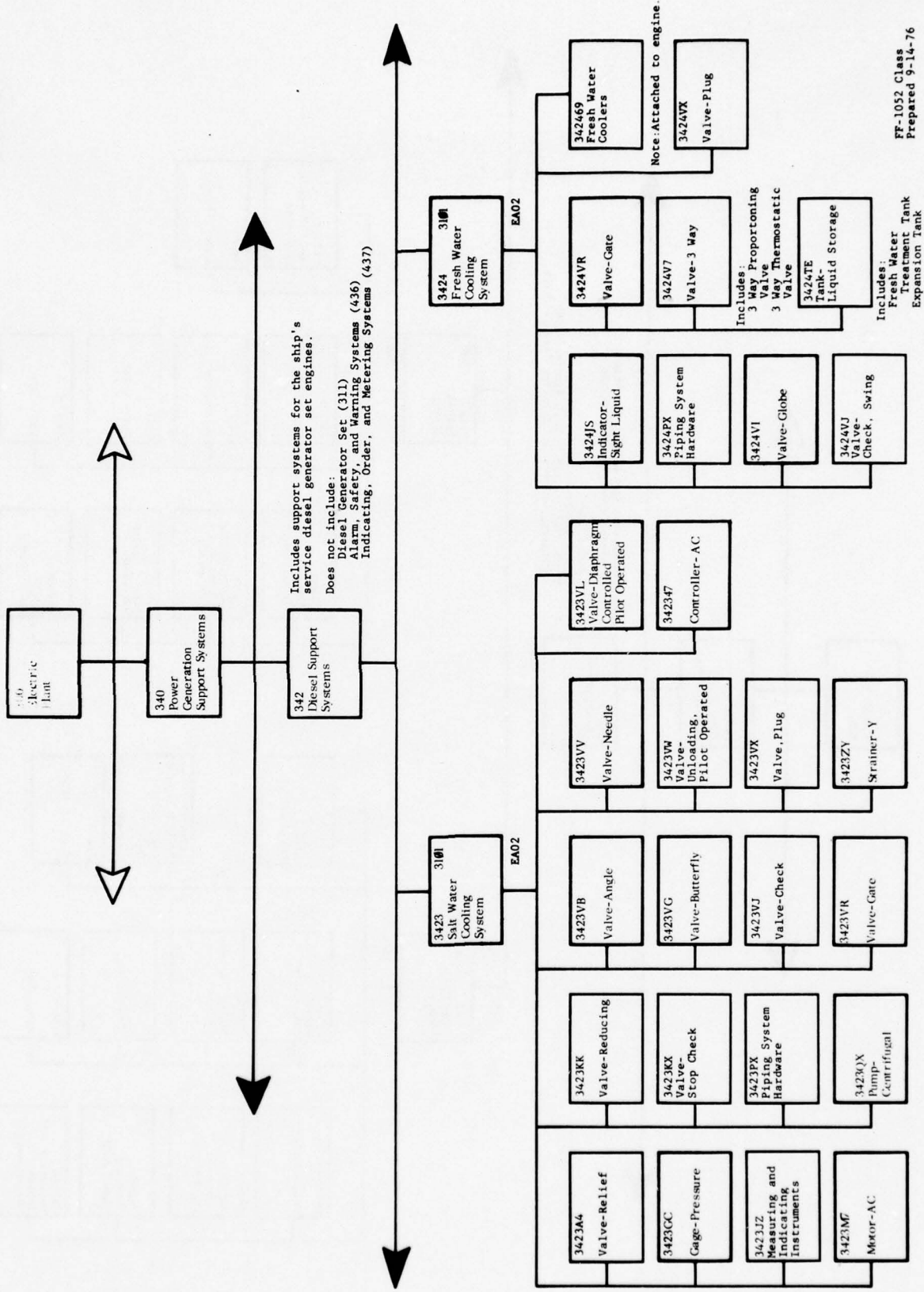

FF-1052 Class  
Prepared 9-14-76

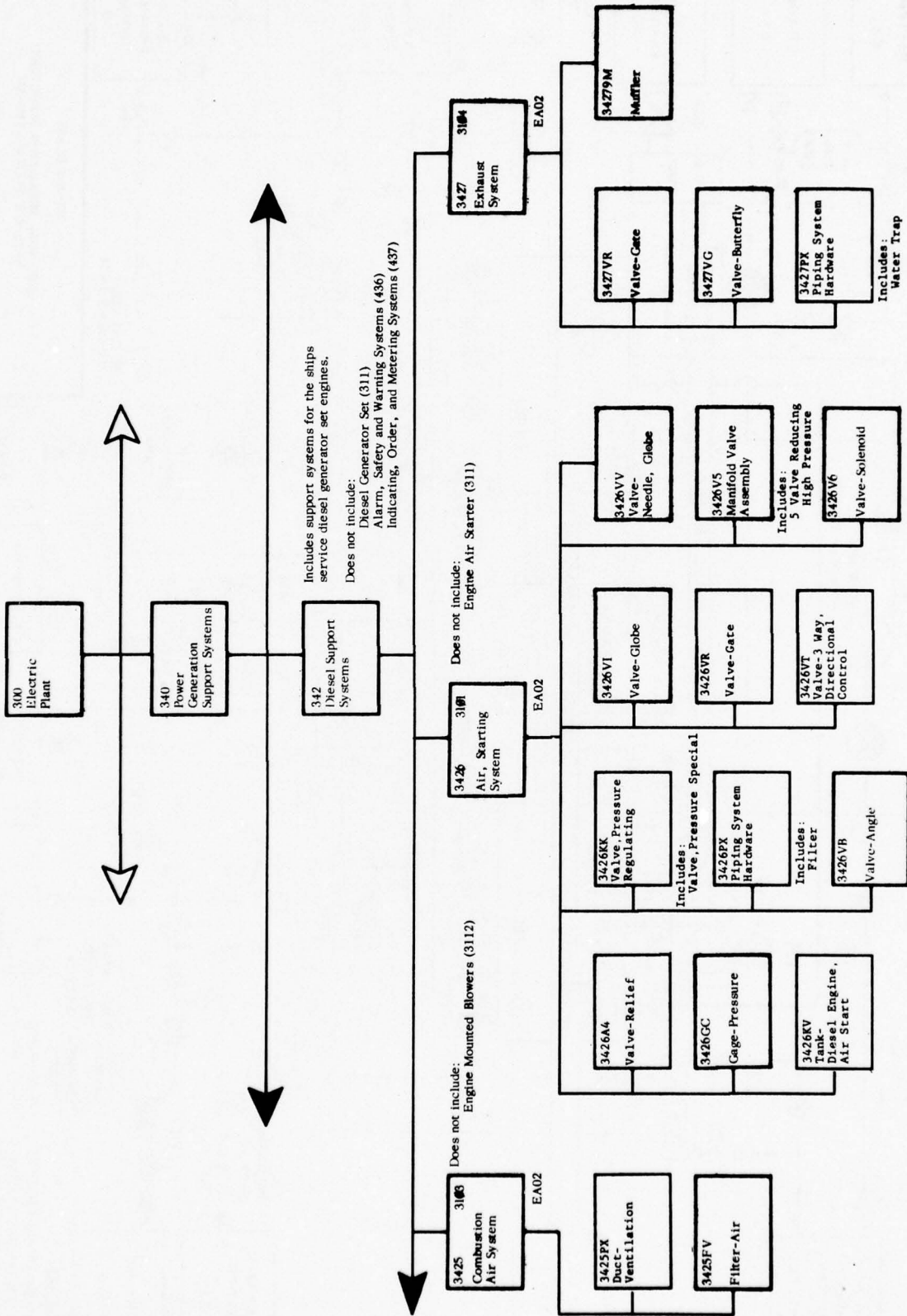

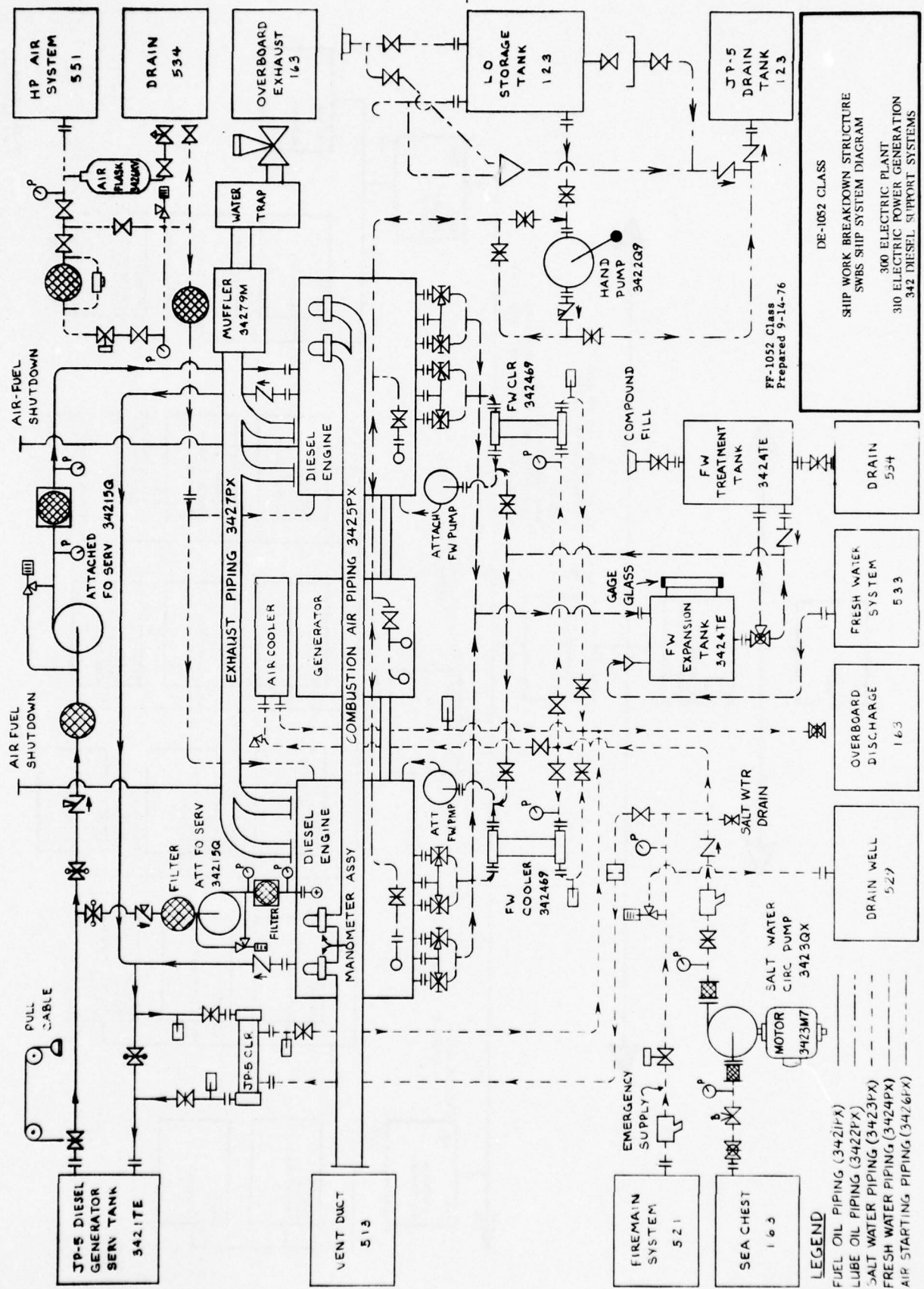

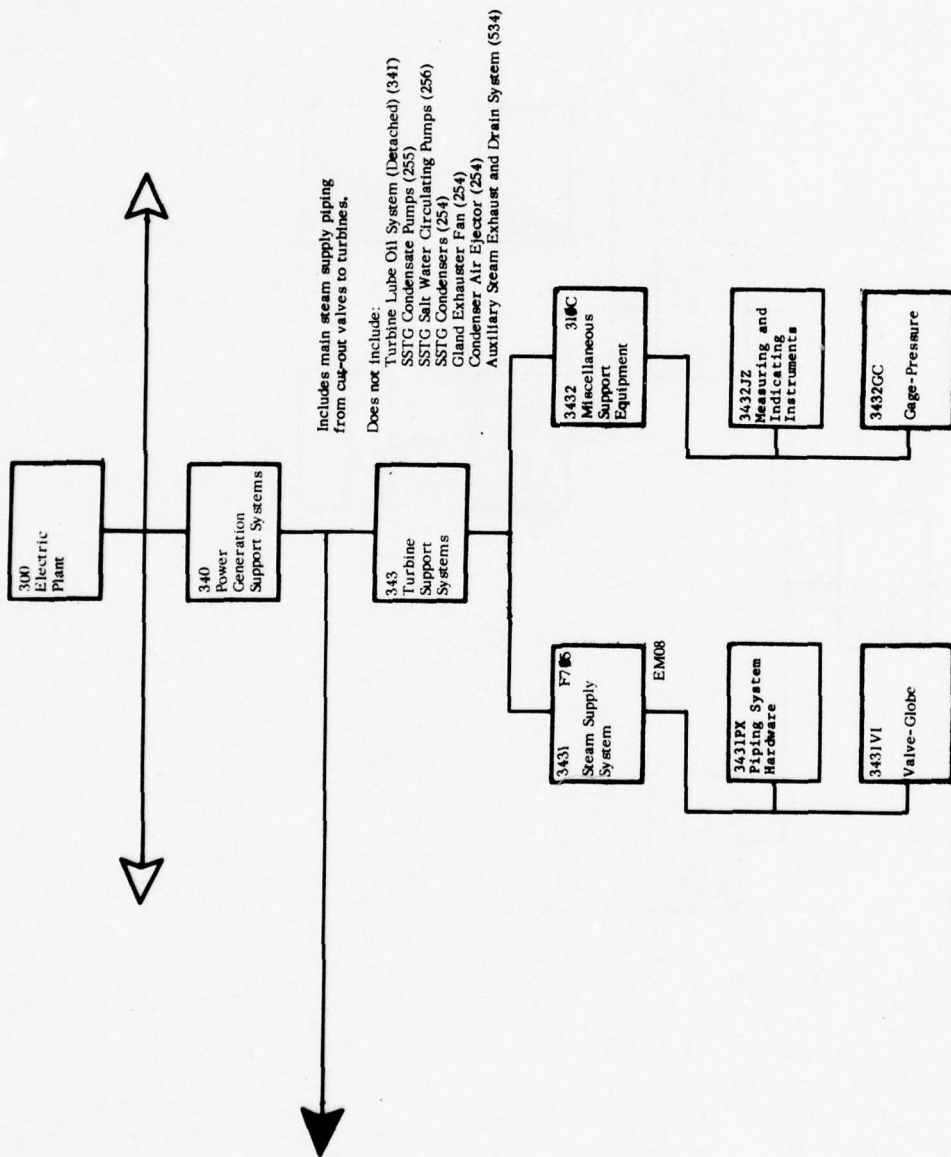

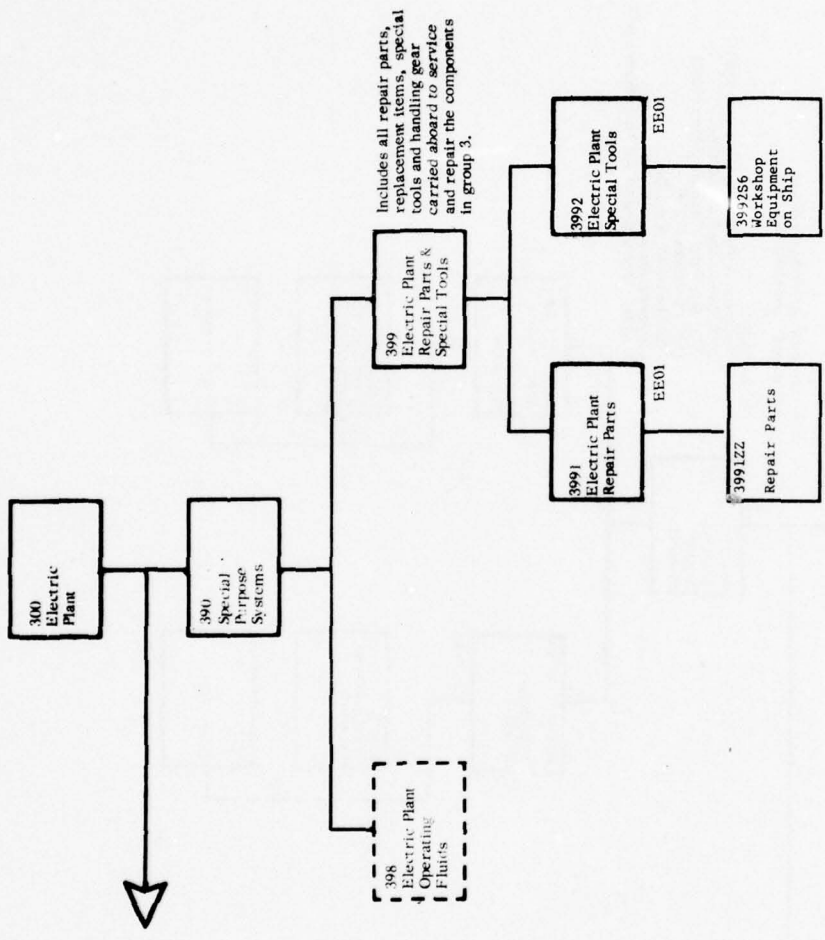

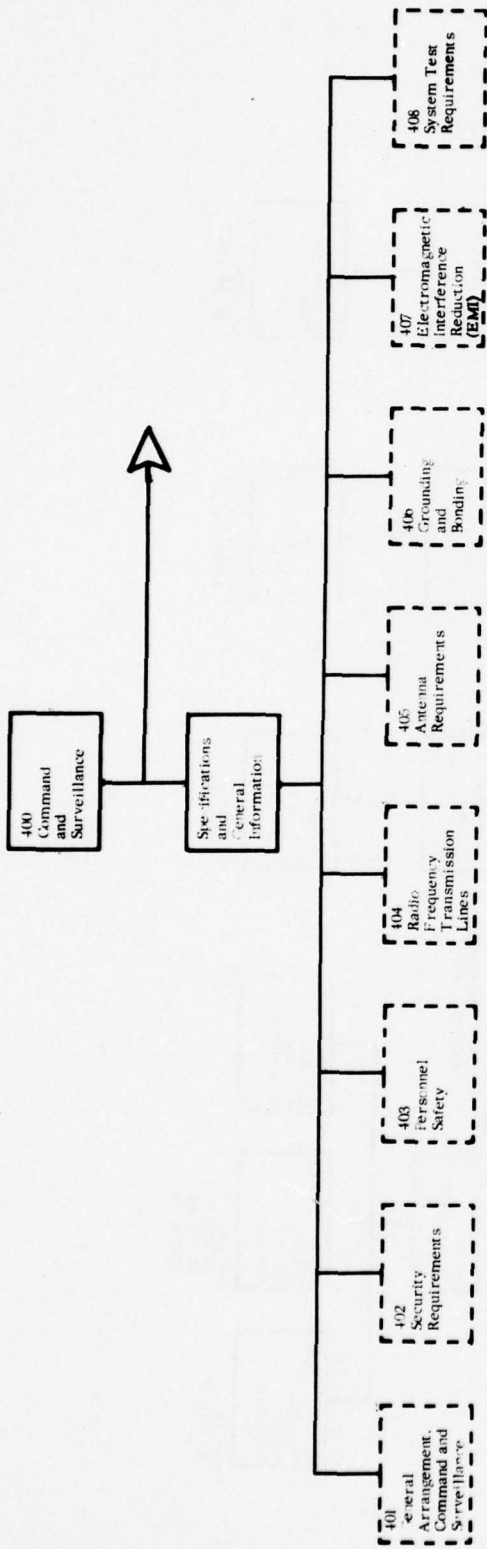

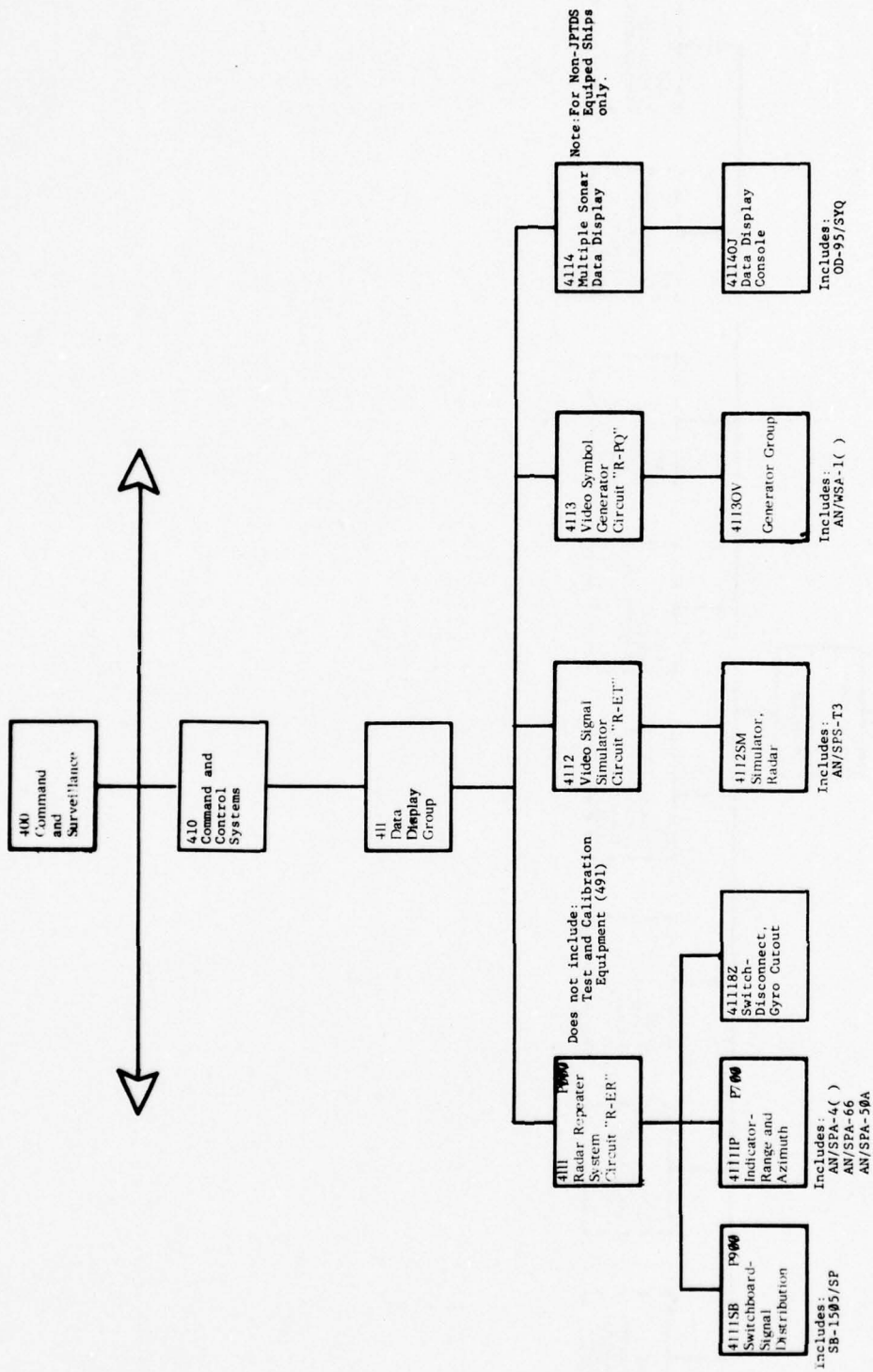

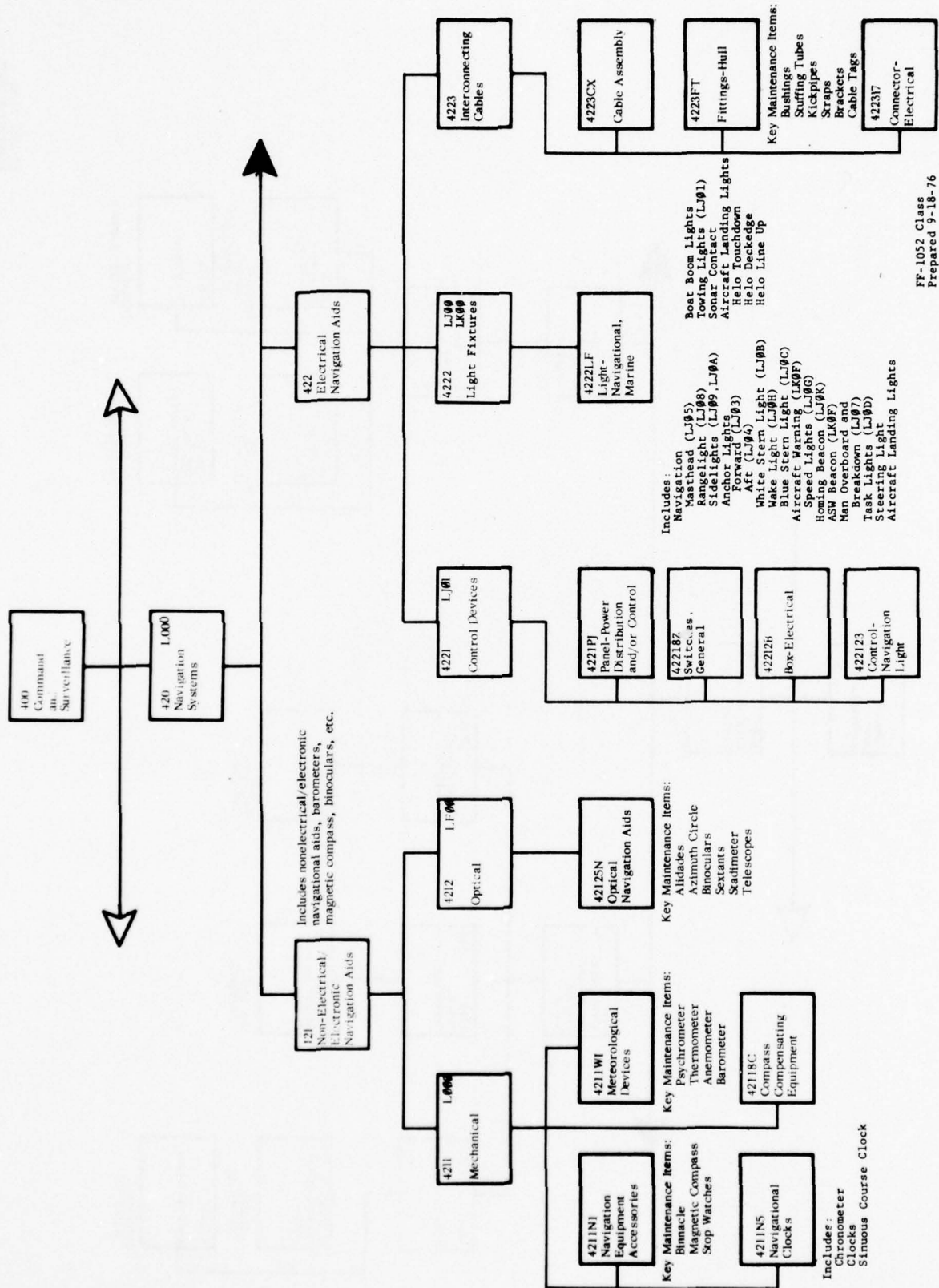

FF-1052 Class  
Prepared 9-18-76

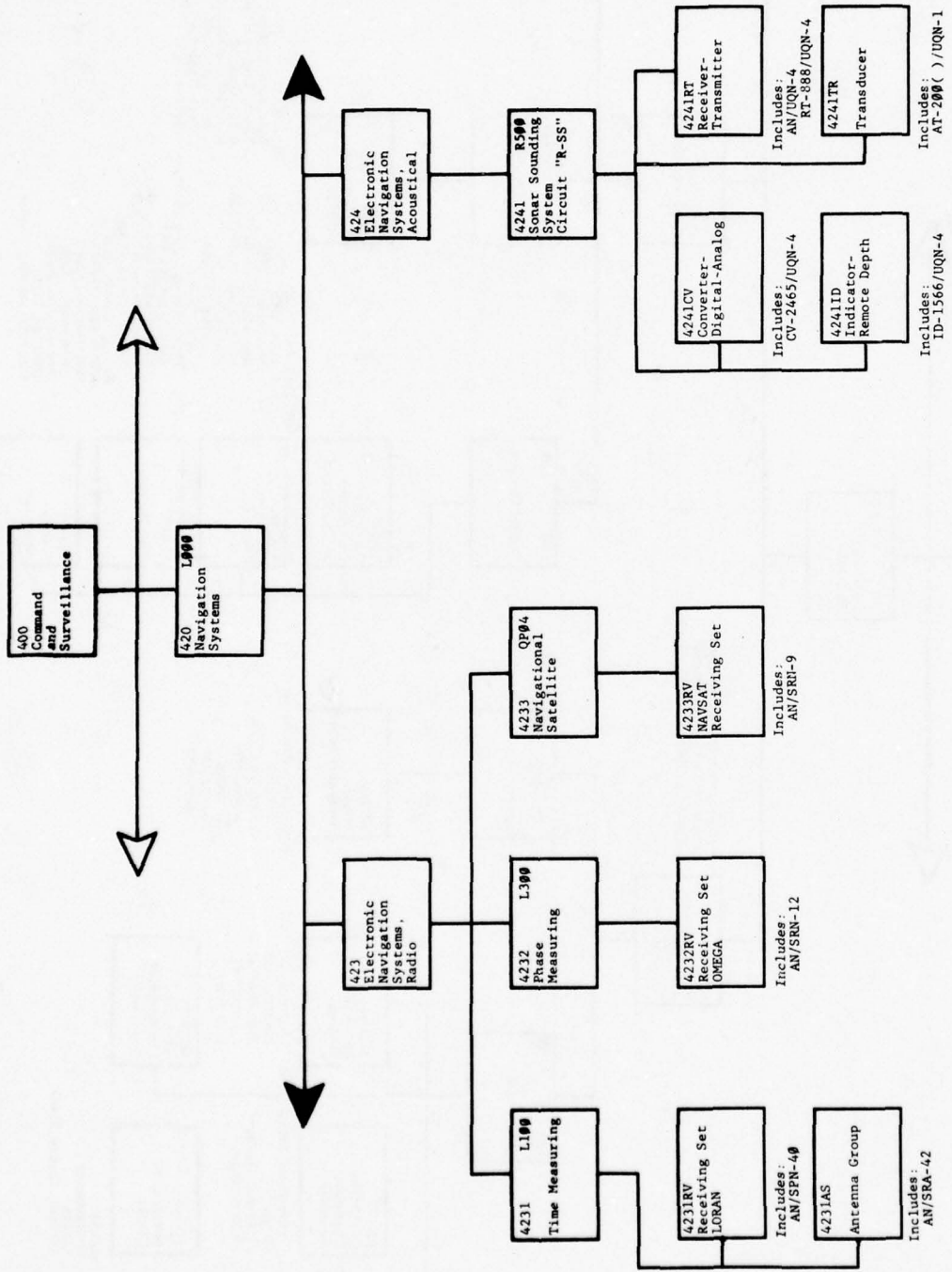

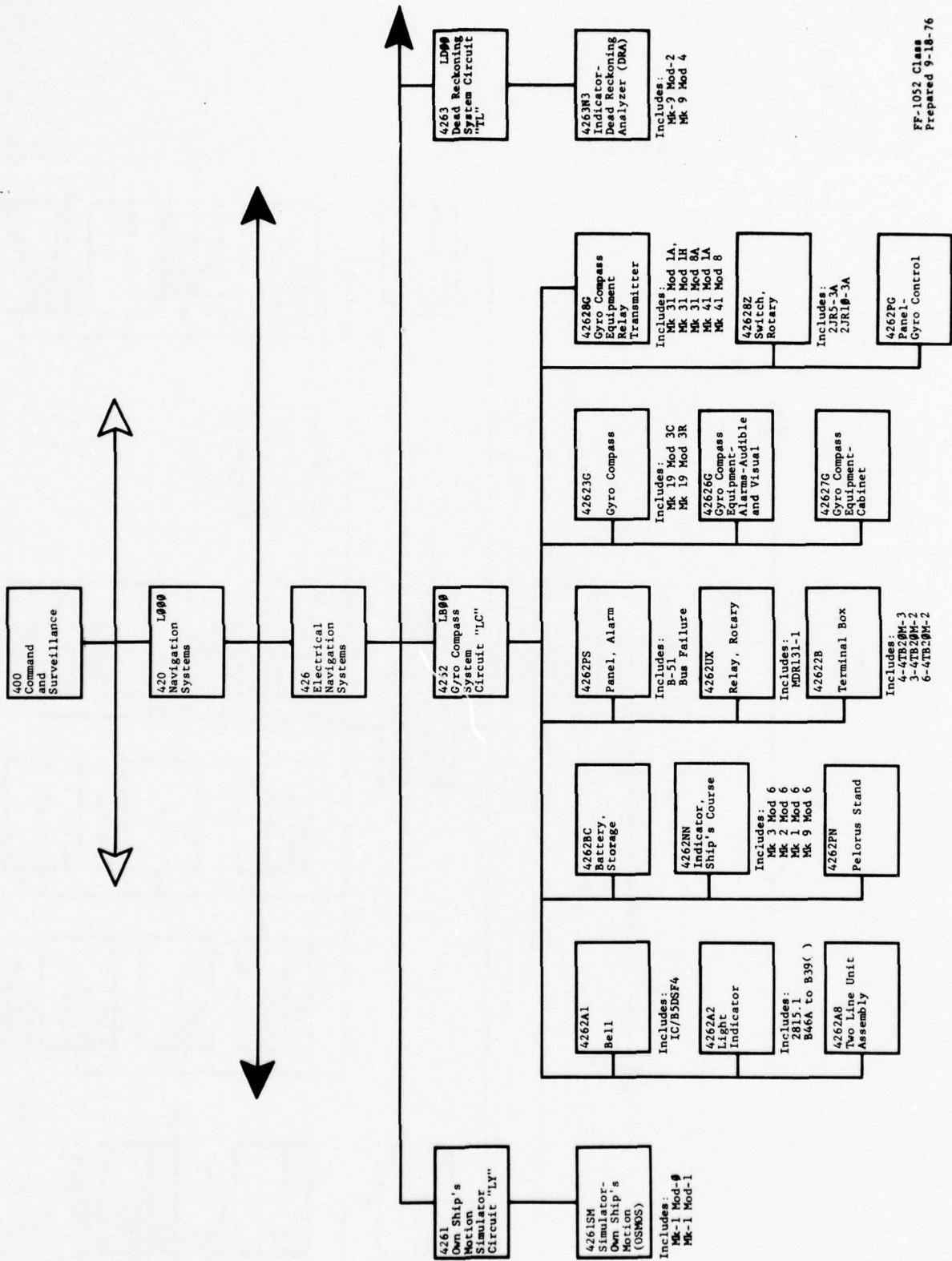

FF-1052 Class  
Prepared 9-18-76

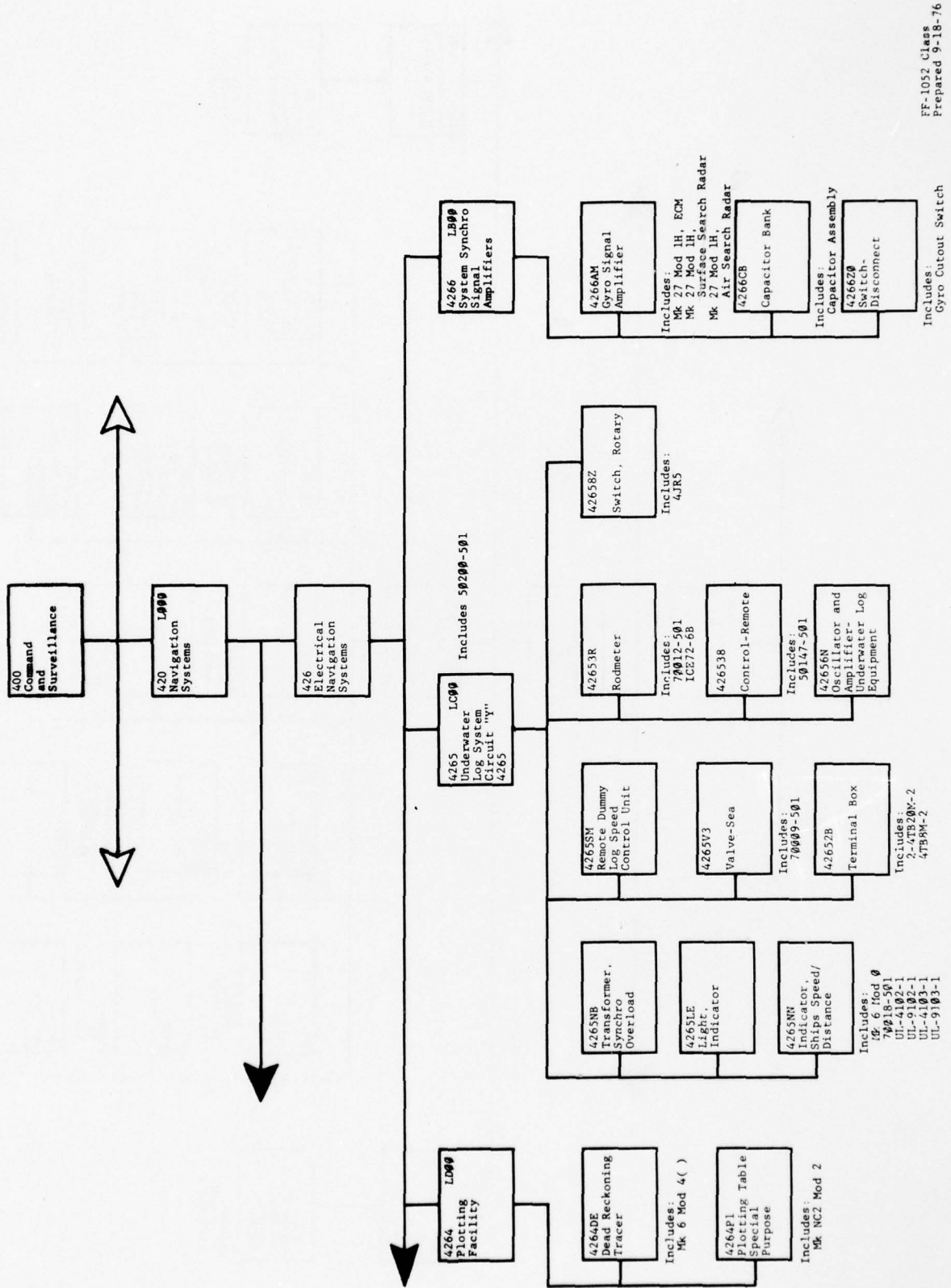

FF-1052 Class  
Prepared 9-18-76

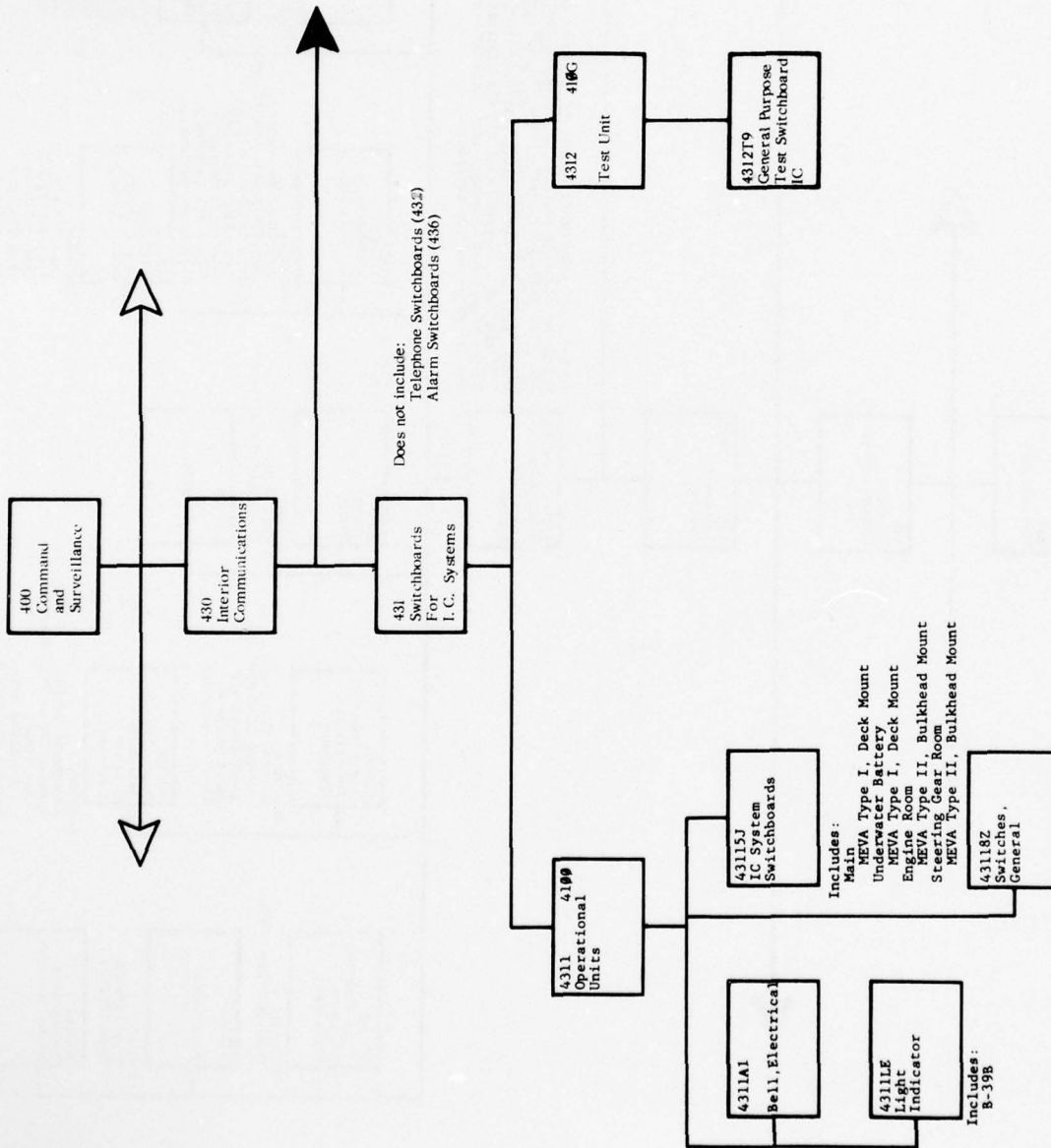



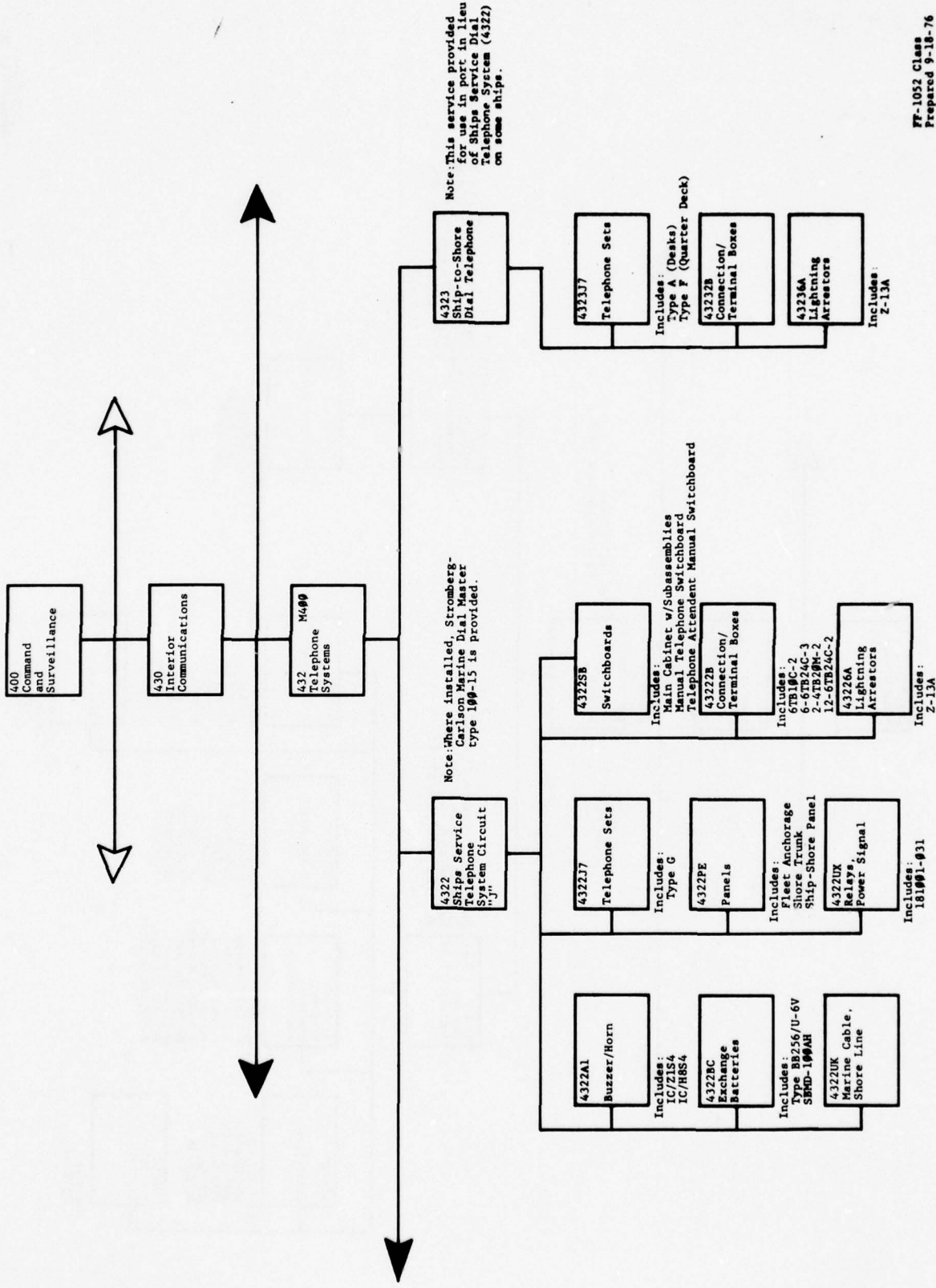

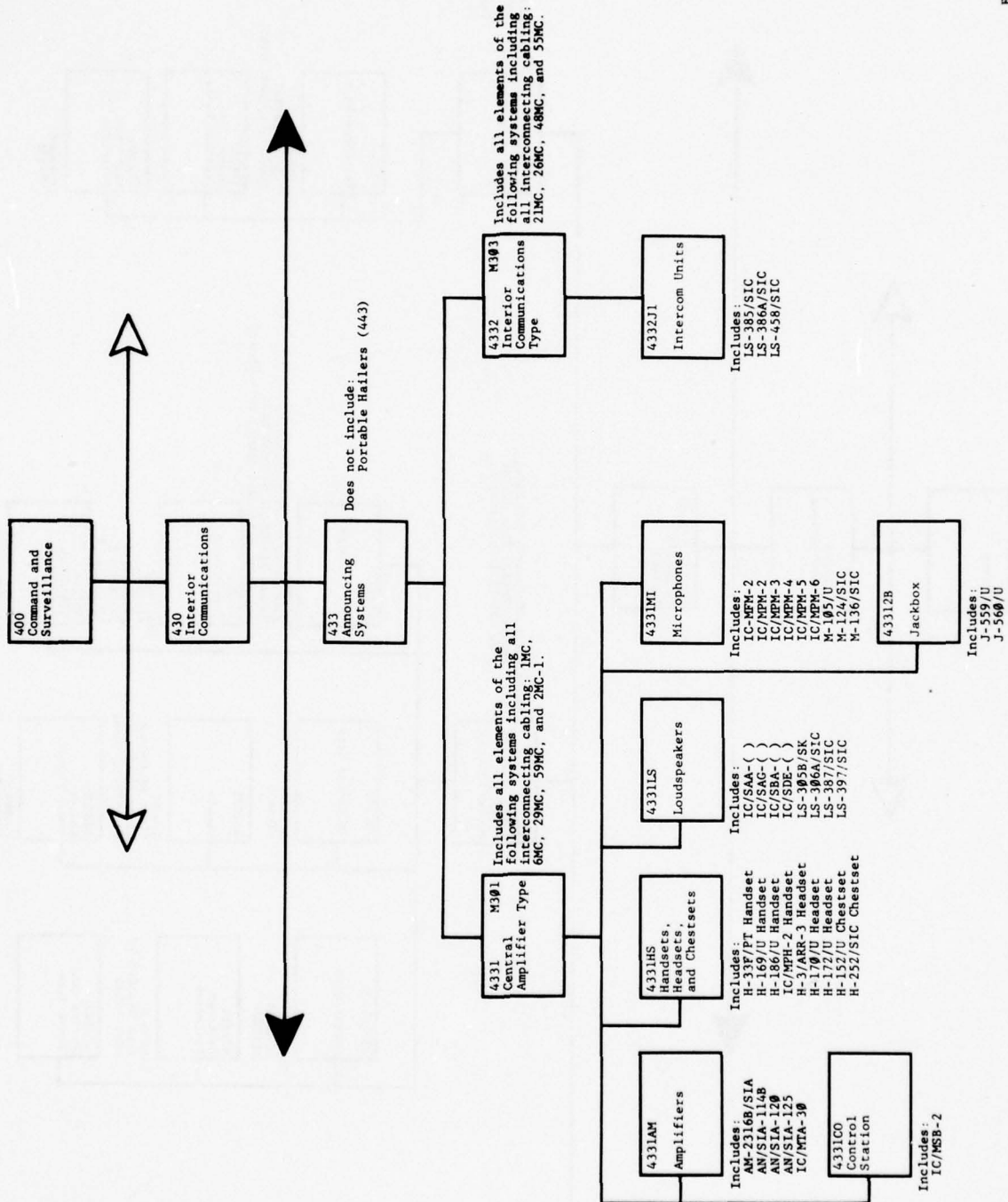

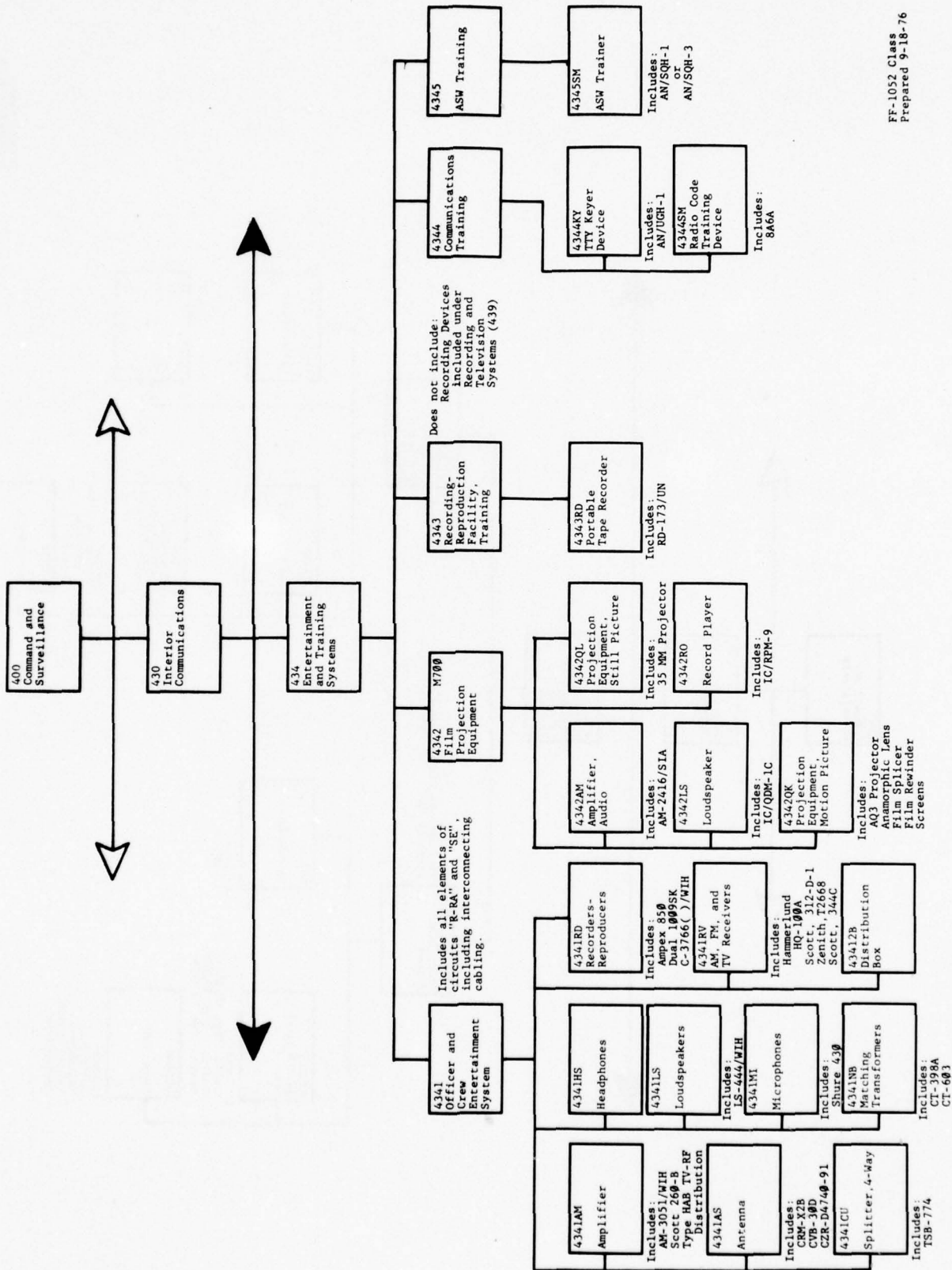

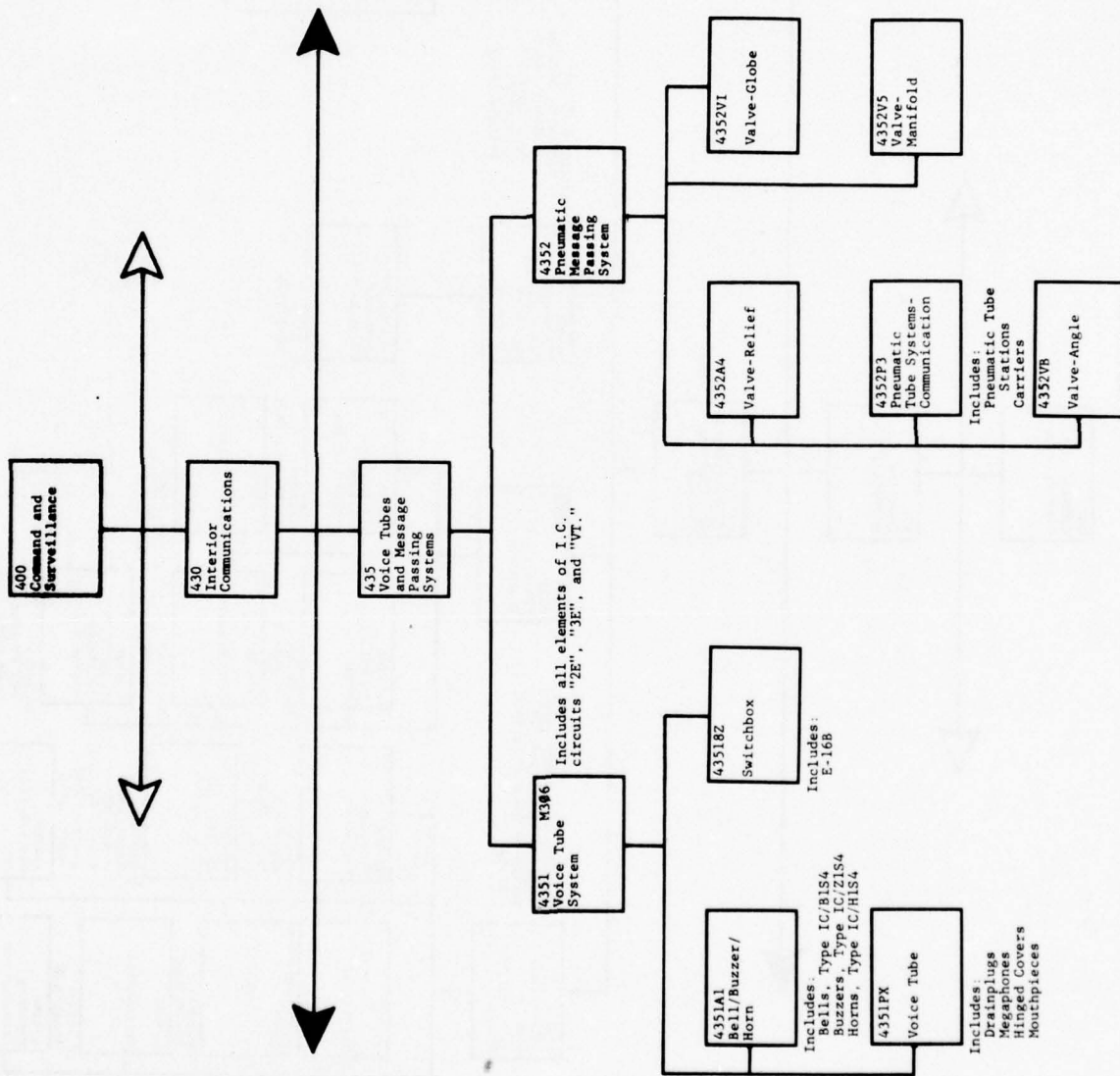

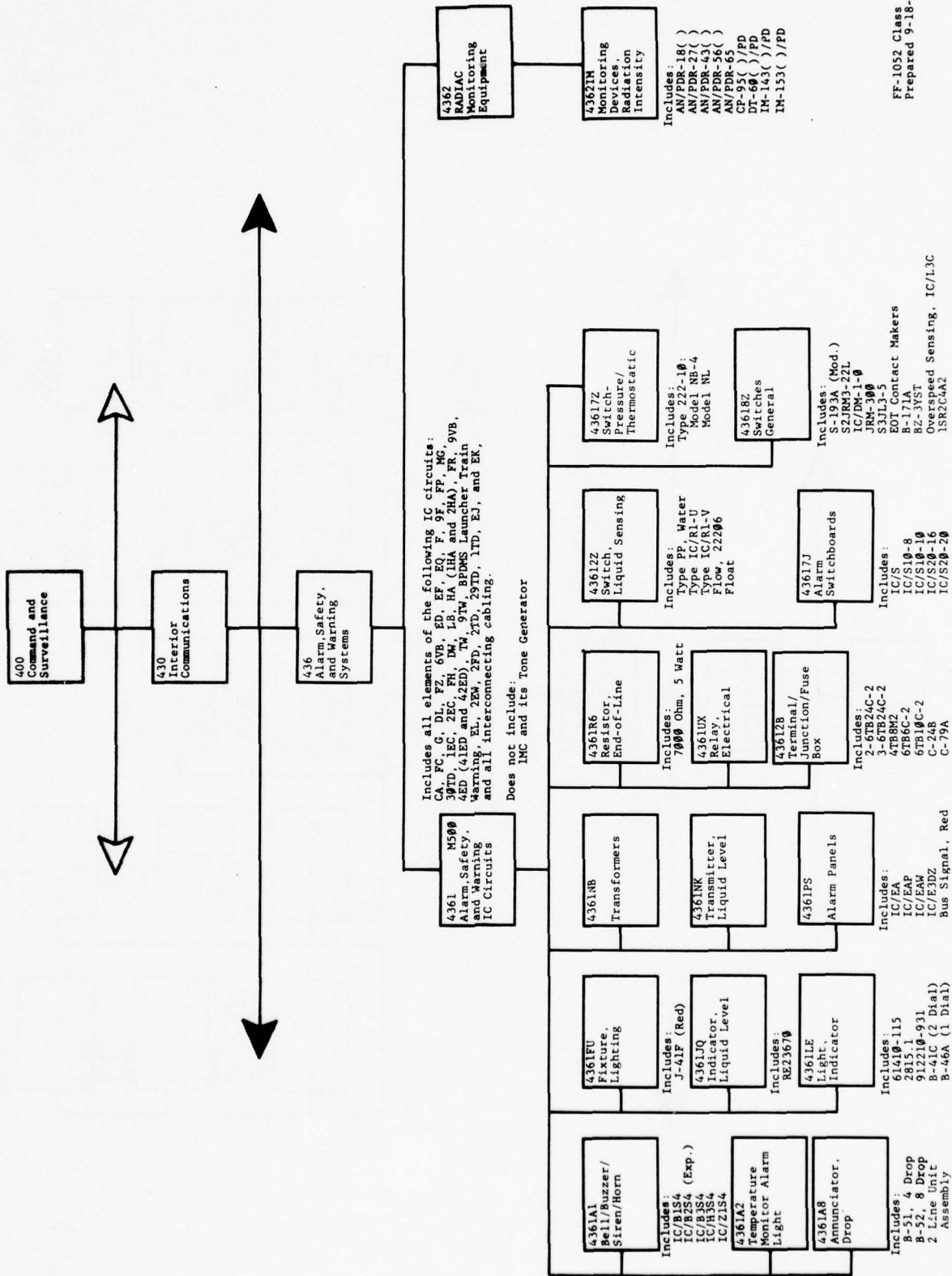

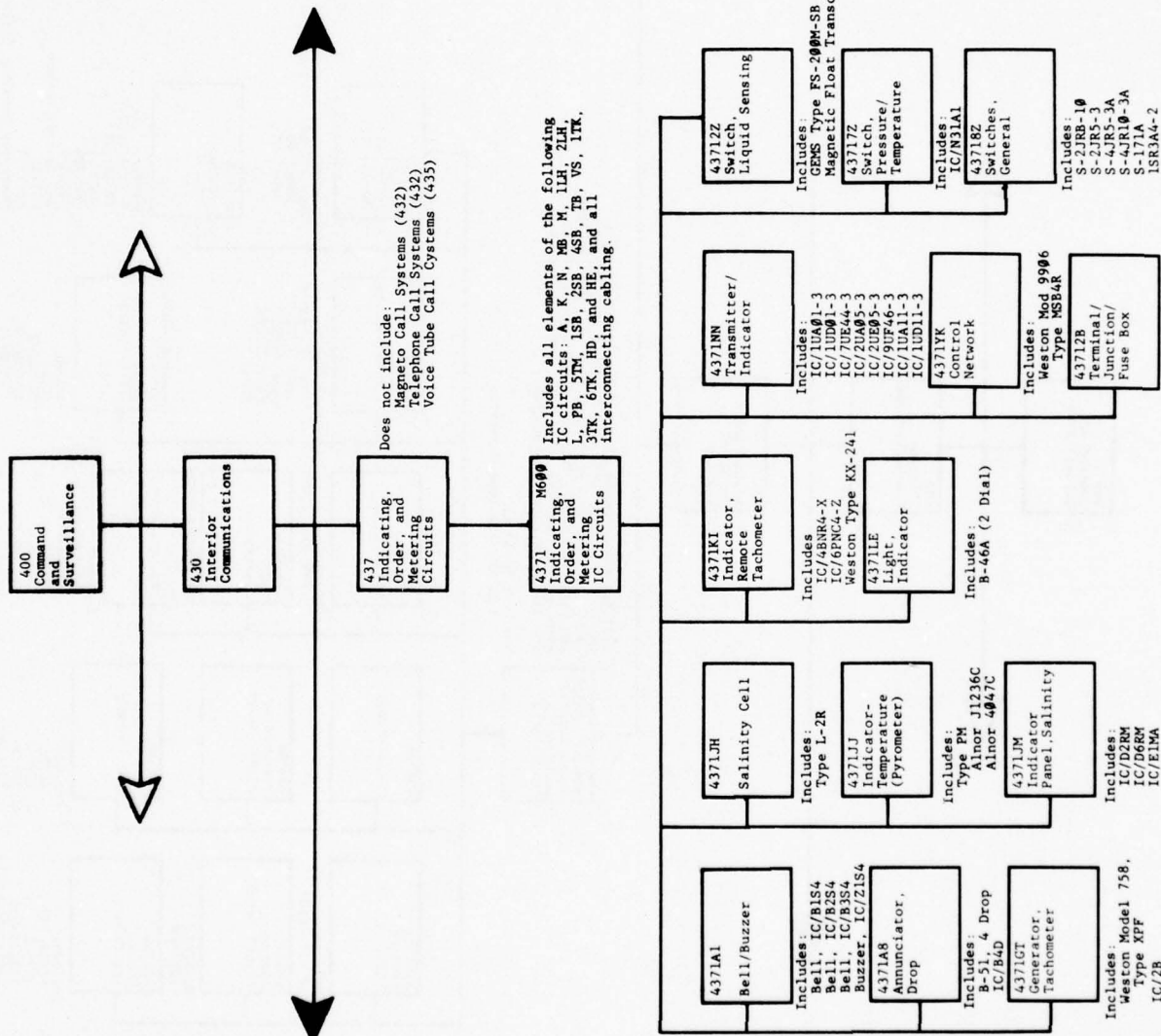

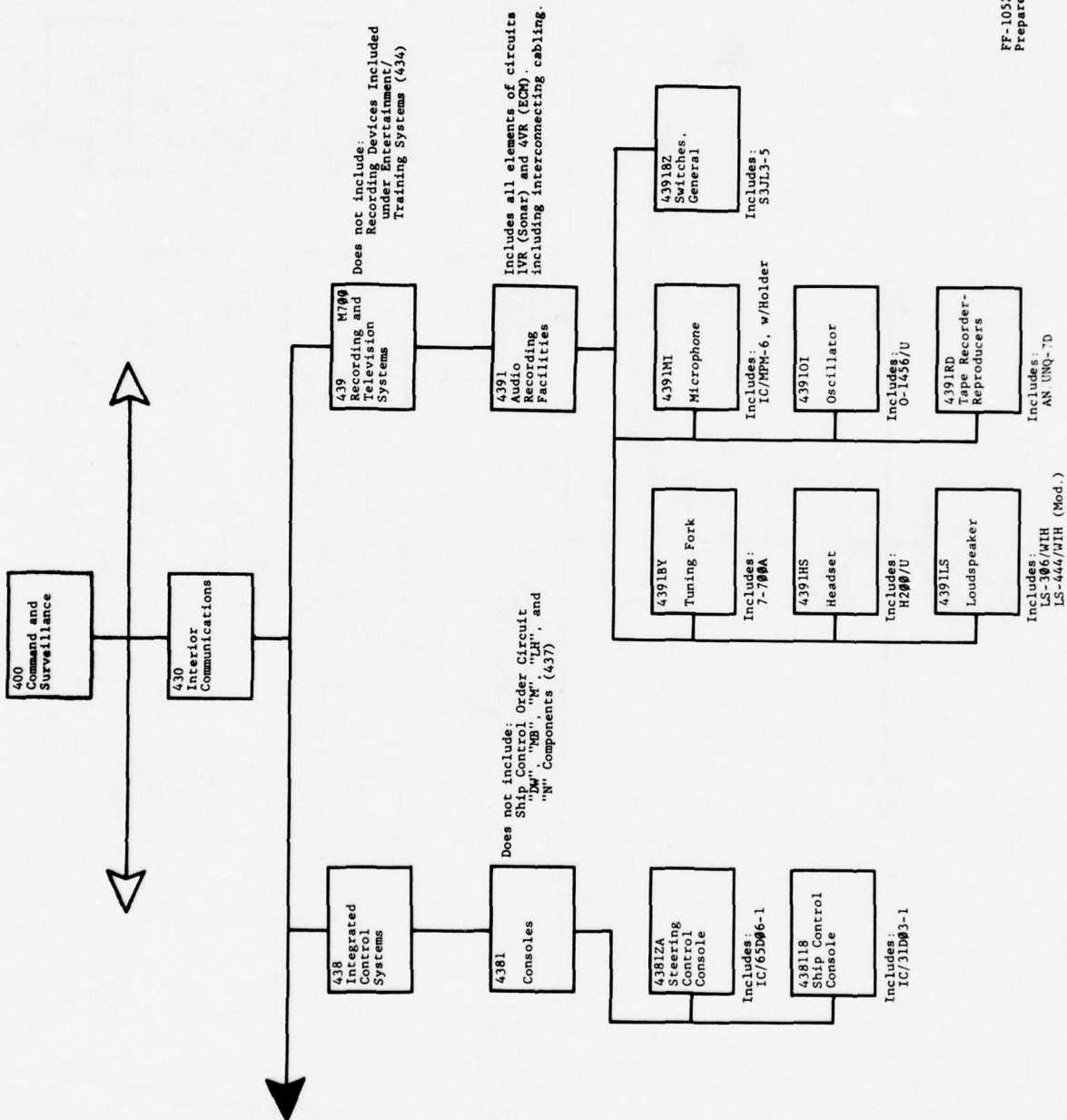

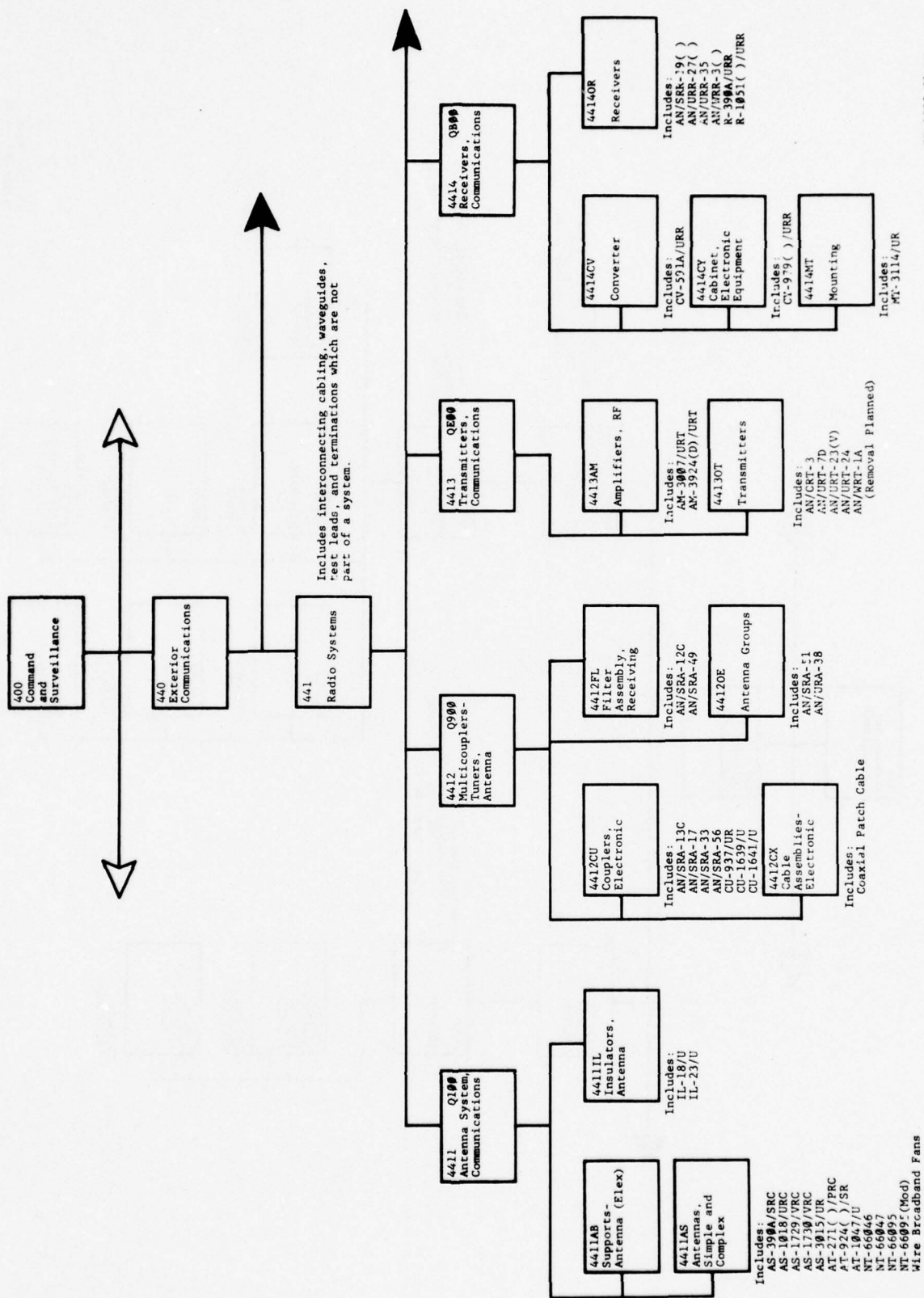

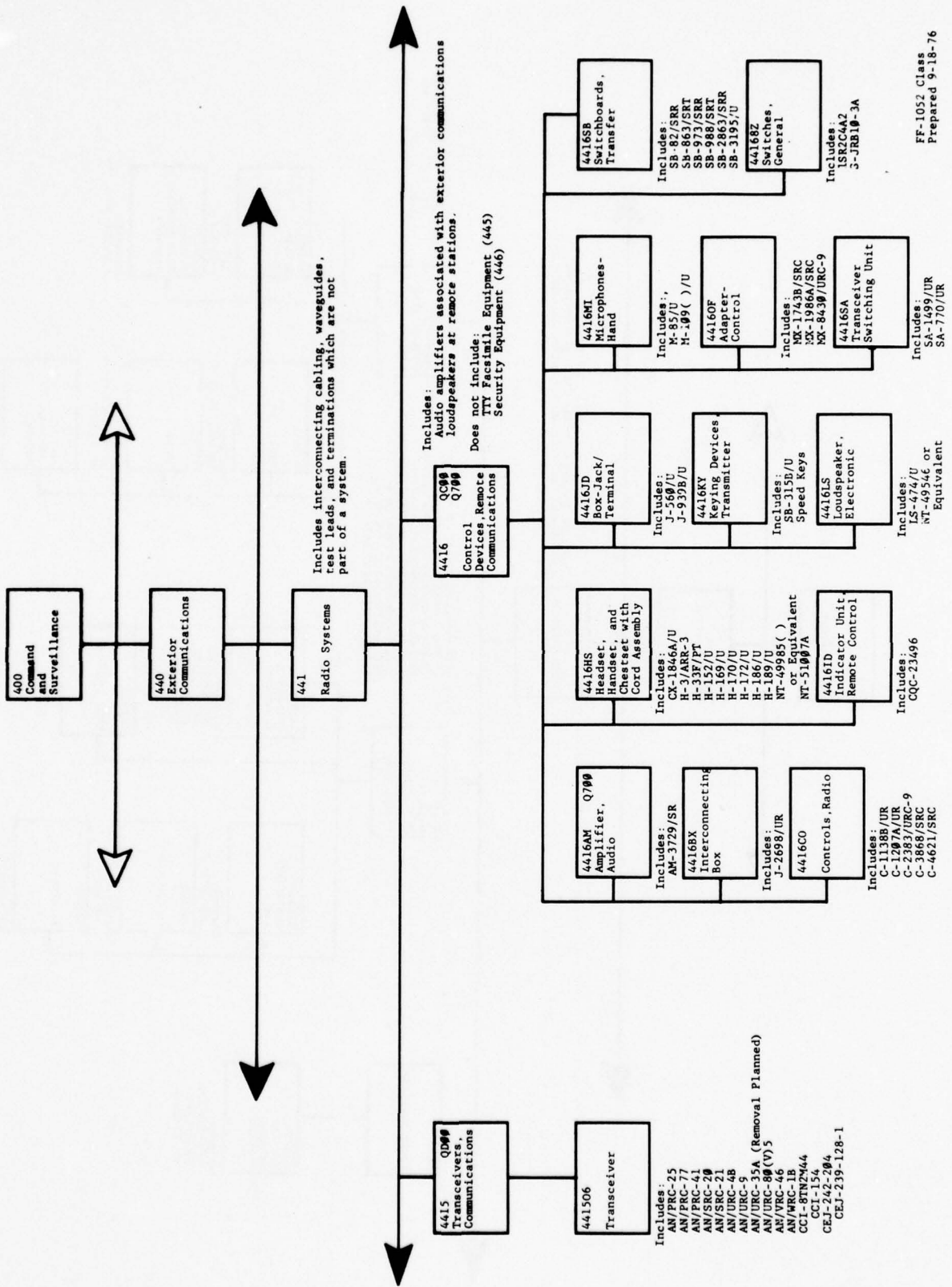

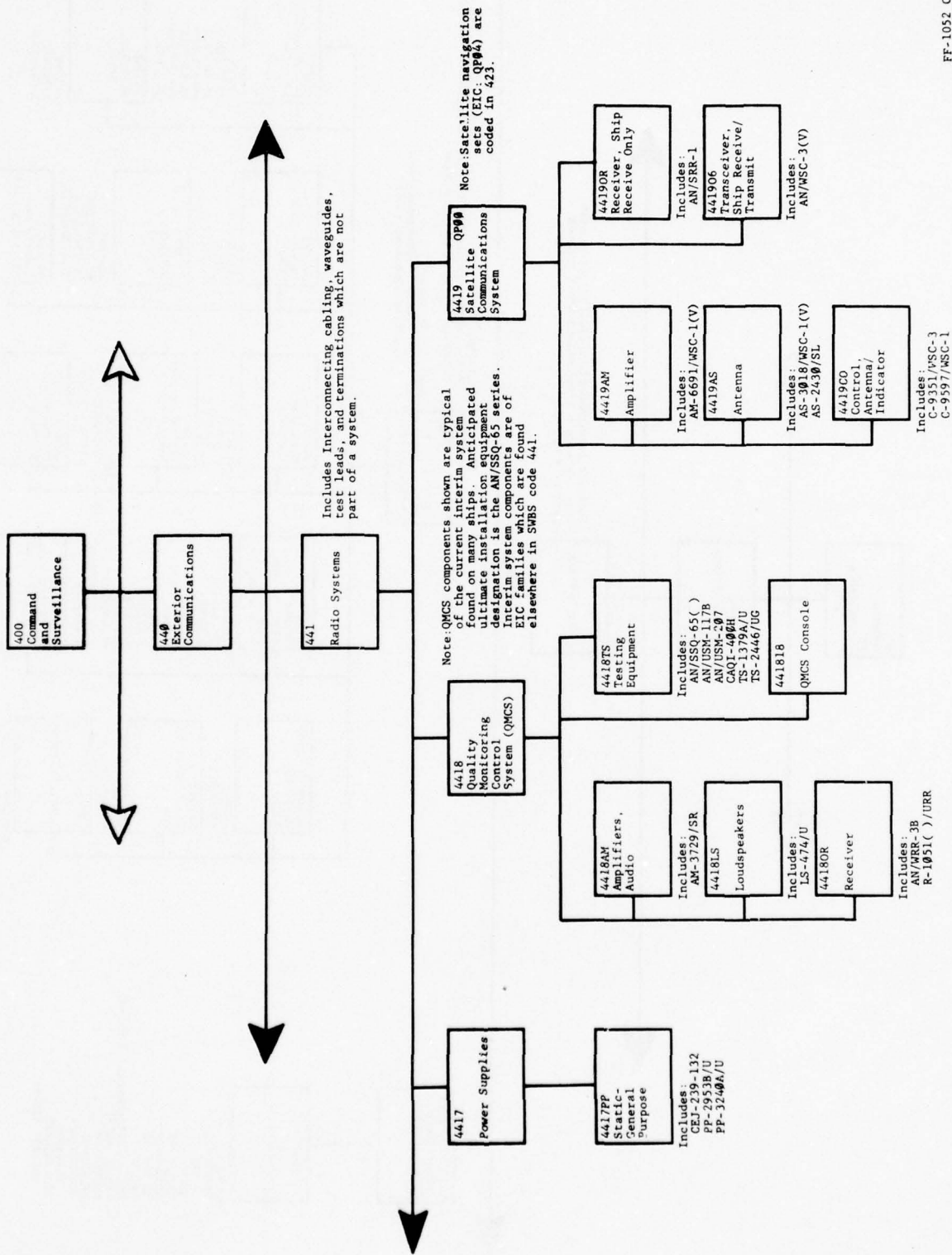

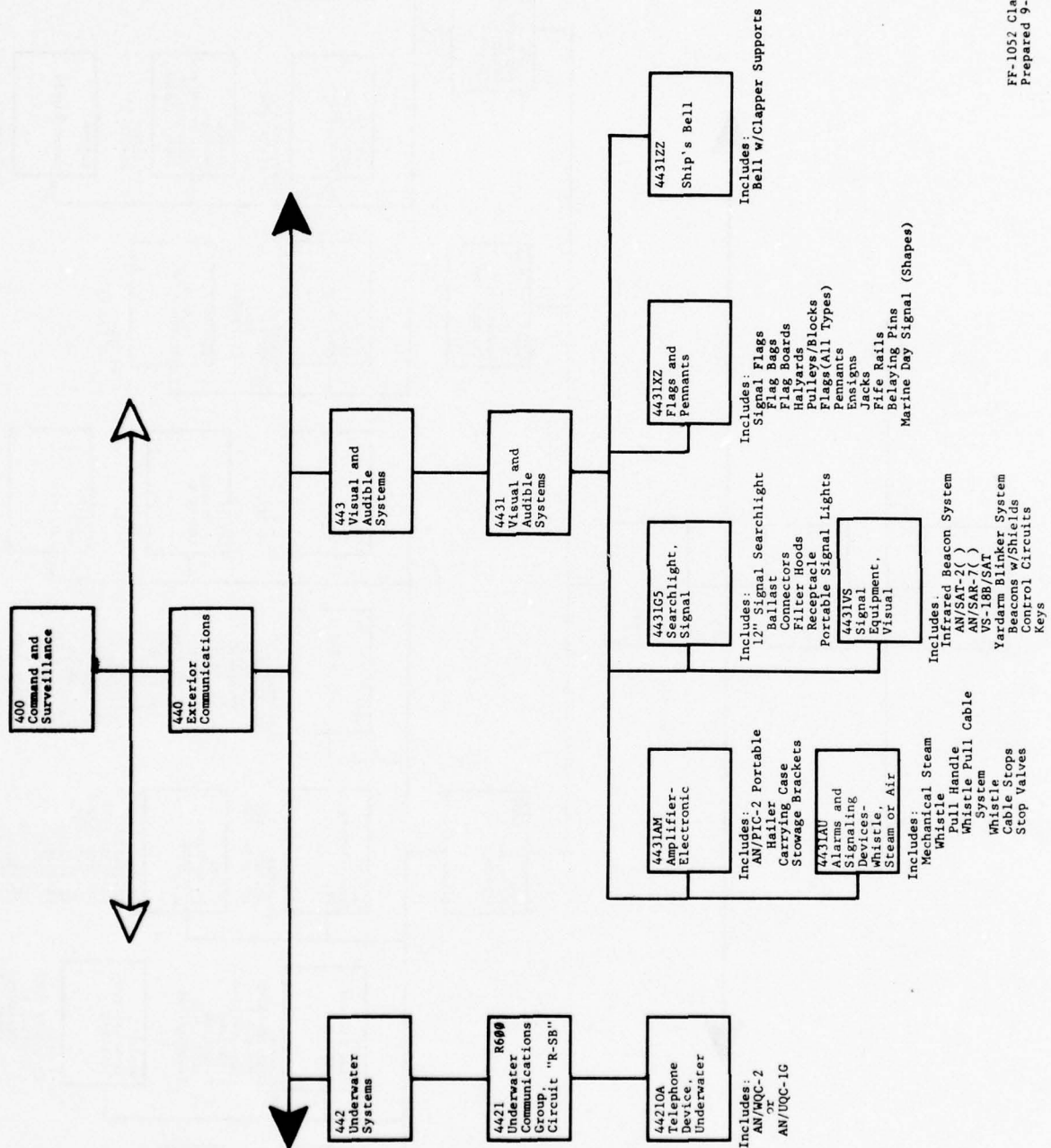

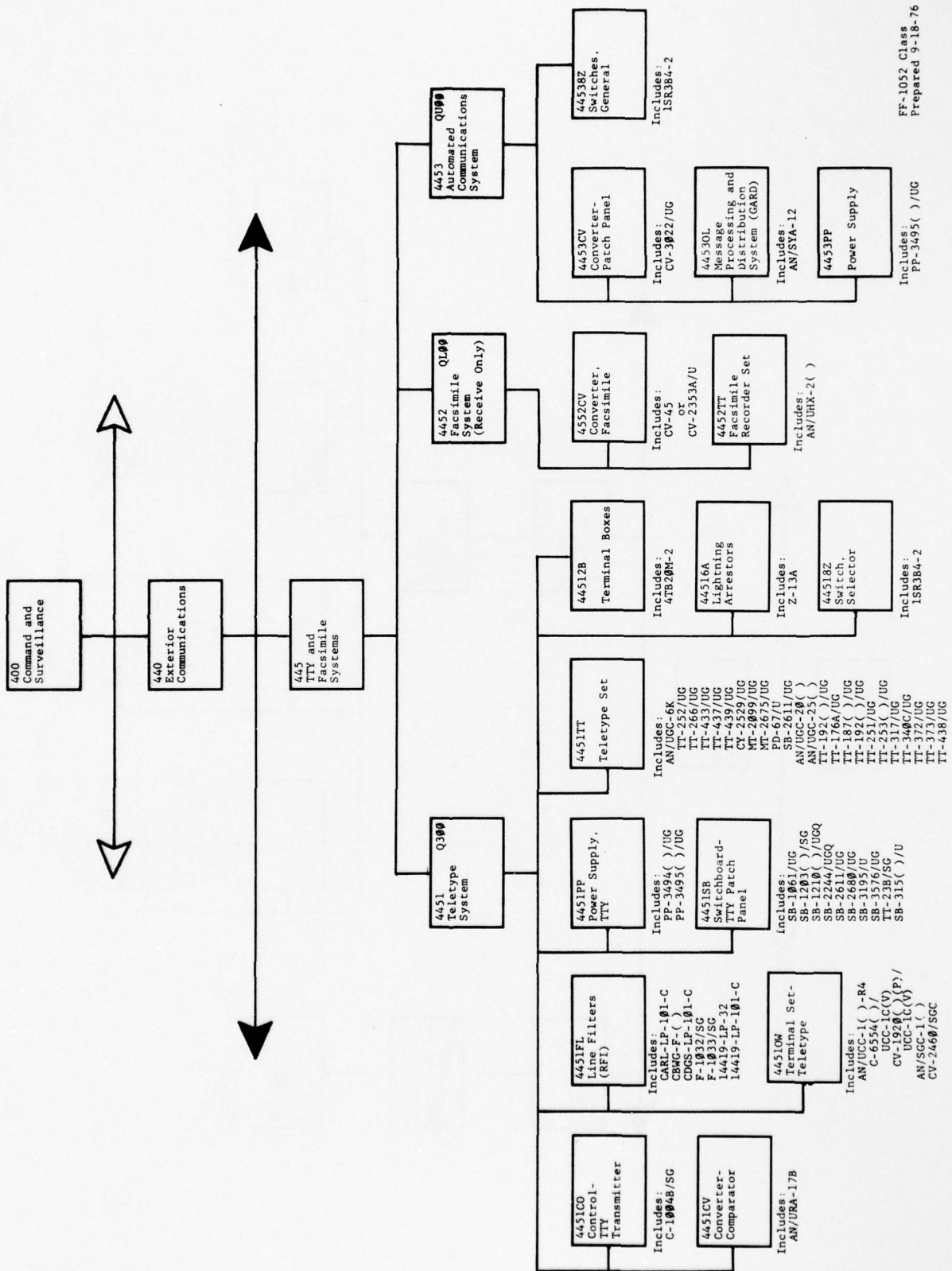

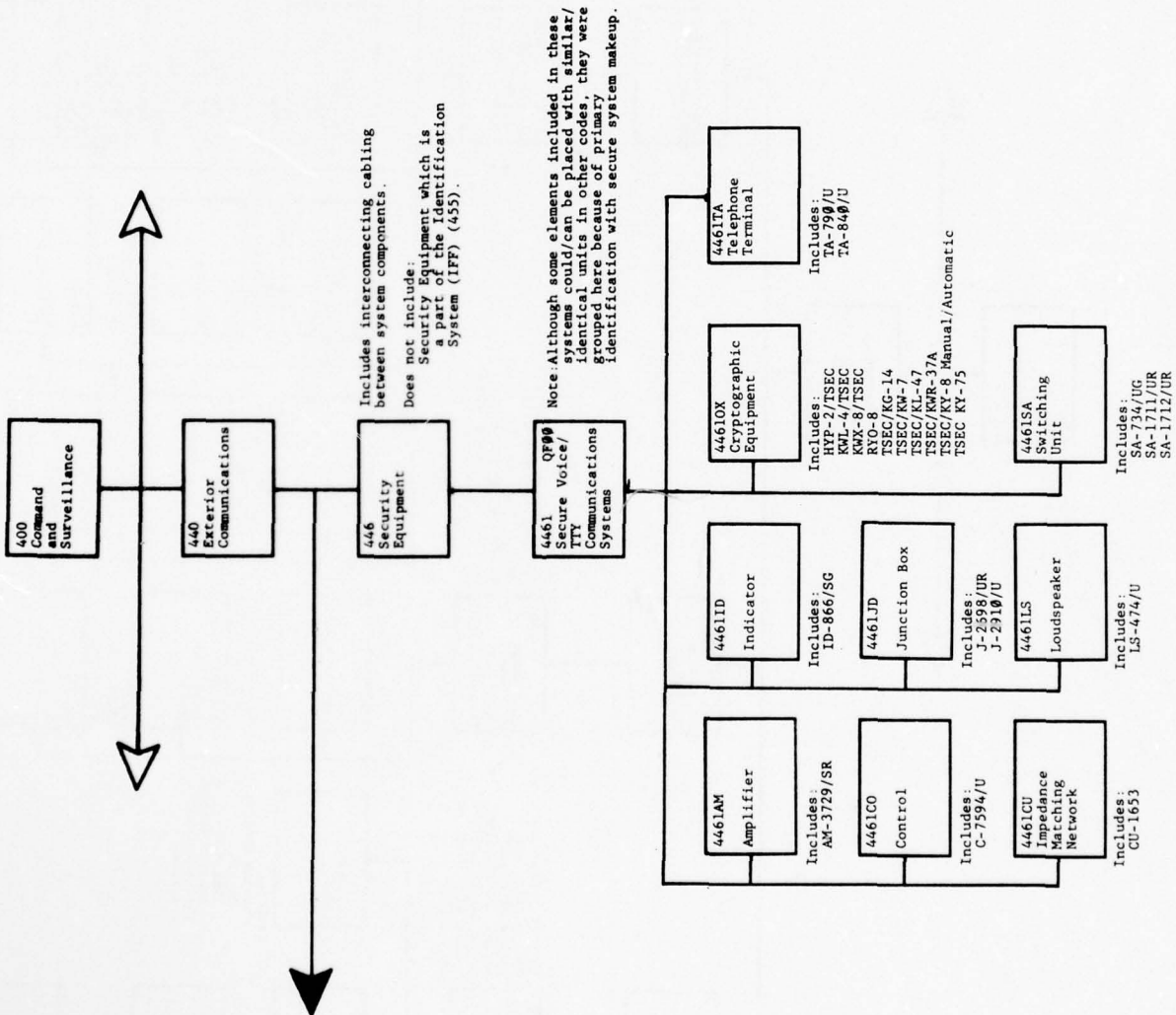

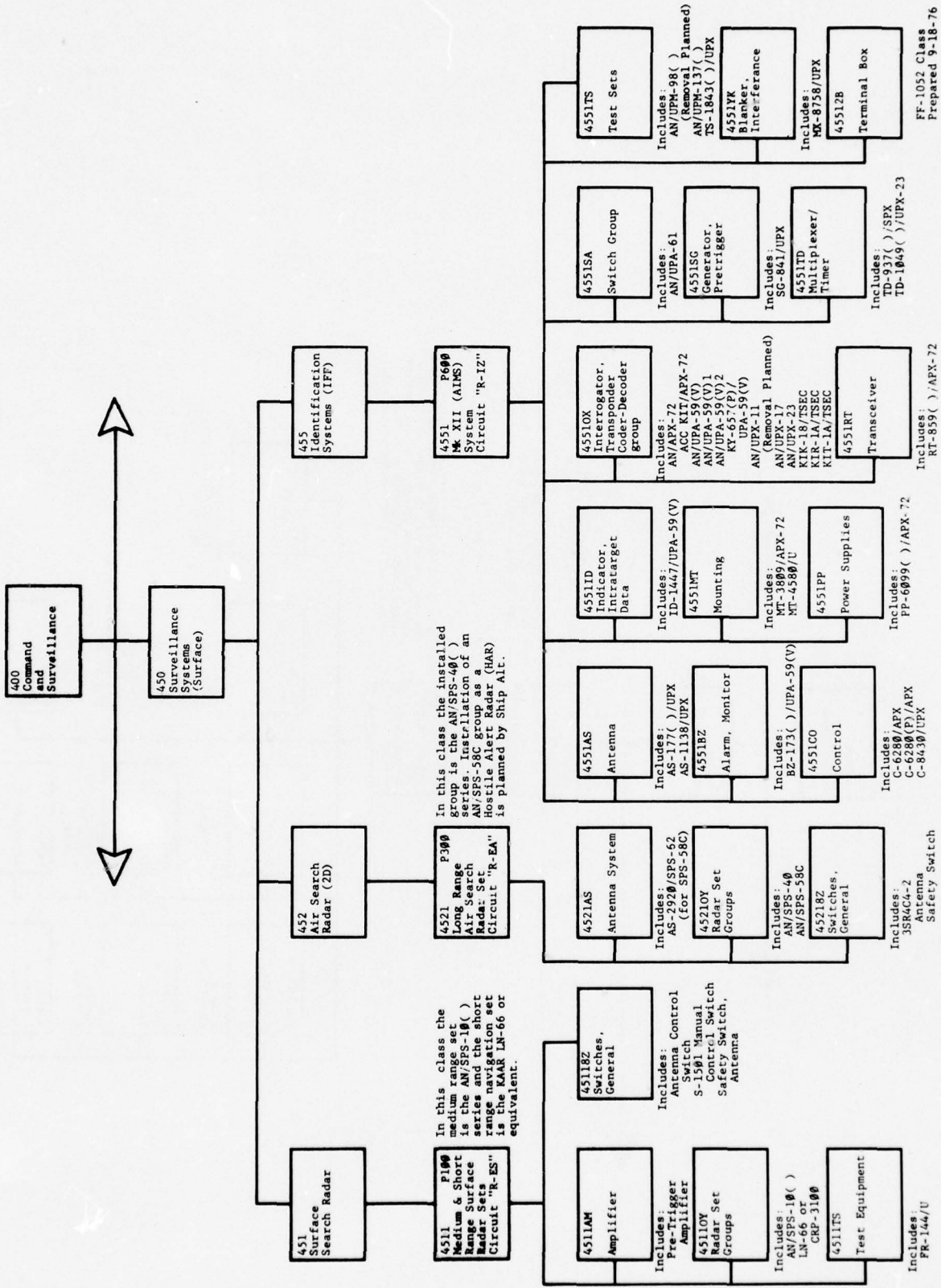

FF-1052 Class  
Prepared 9-18-76

Includes:  
RT-859( )/APX-72

Includes:  
PP-6099( )/APX-72

Includes:  
C-6280/APX  
C-6280(P)/APX  
C-8430/UPX

Includes:  
JSRAC4-2  
Antenna  
Safety Switch

Includes:  
AN/SPS-40  
AN/SPS-58C

Includes:  
AN/SPS-10( )  
LN-66 or  
GRP-3100

Includes:  
PR-144/U

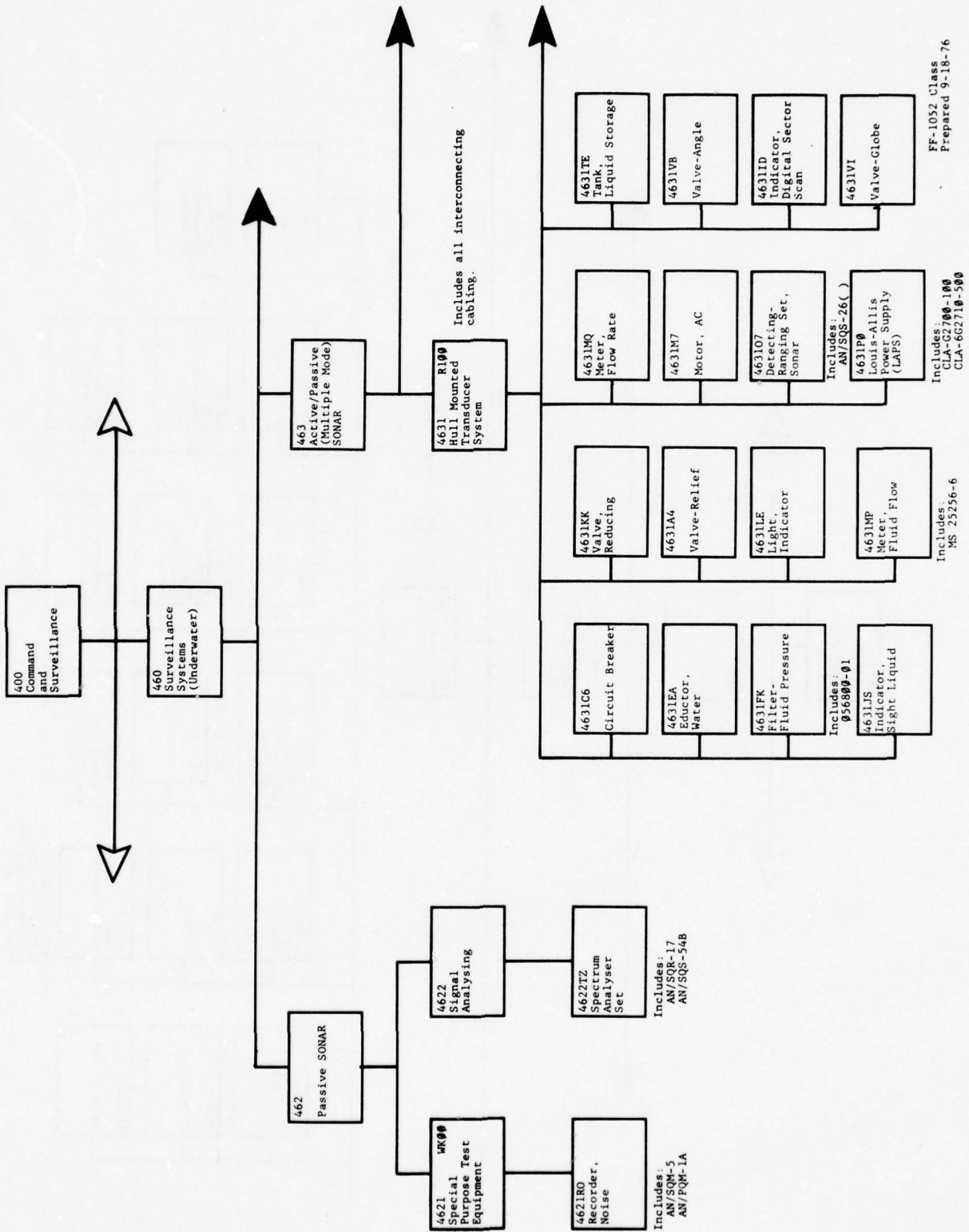

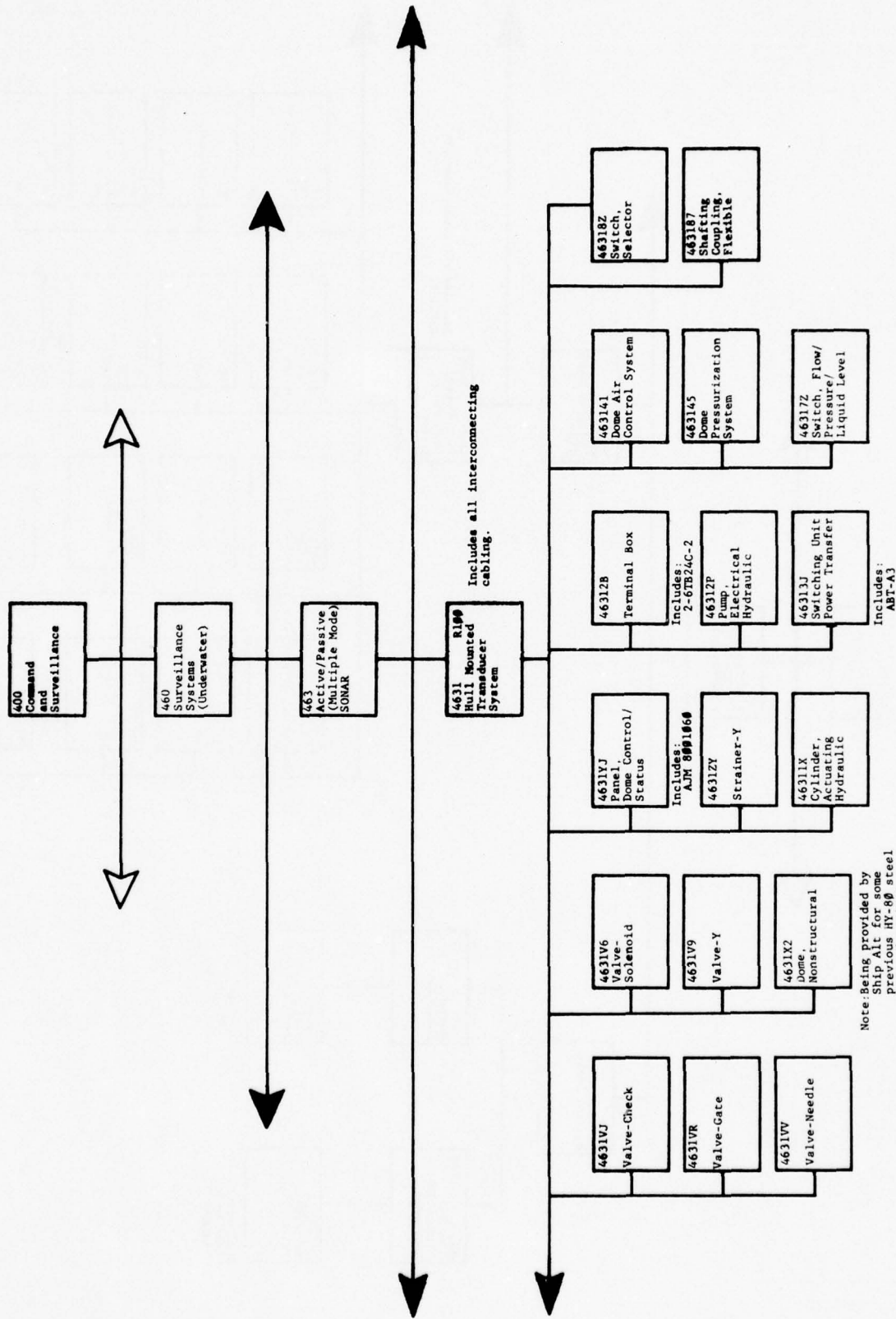

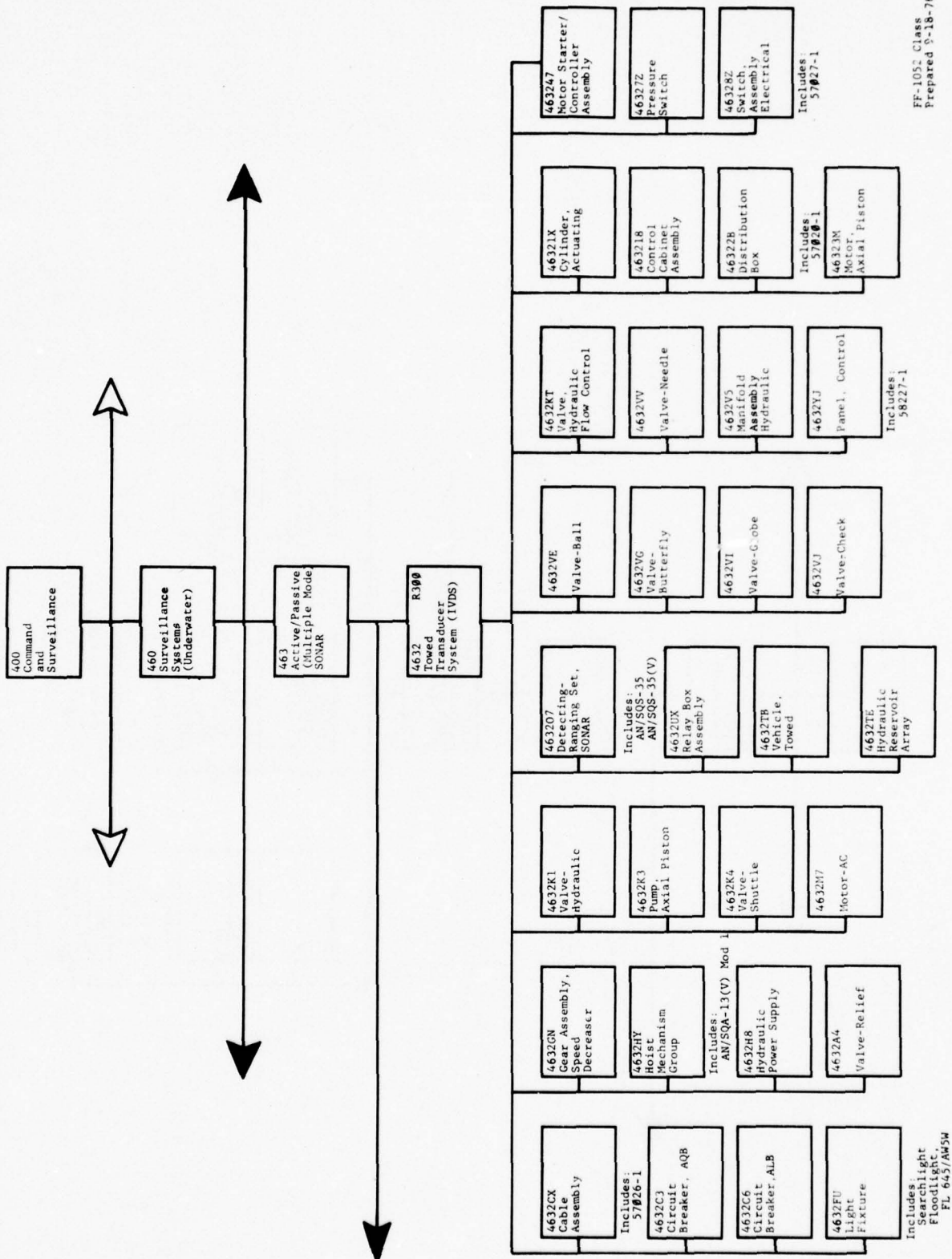

FF-1062 Class  
Prepared 9-18-76

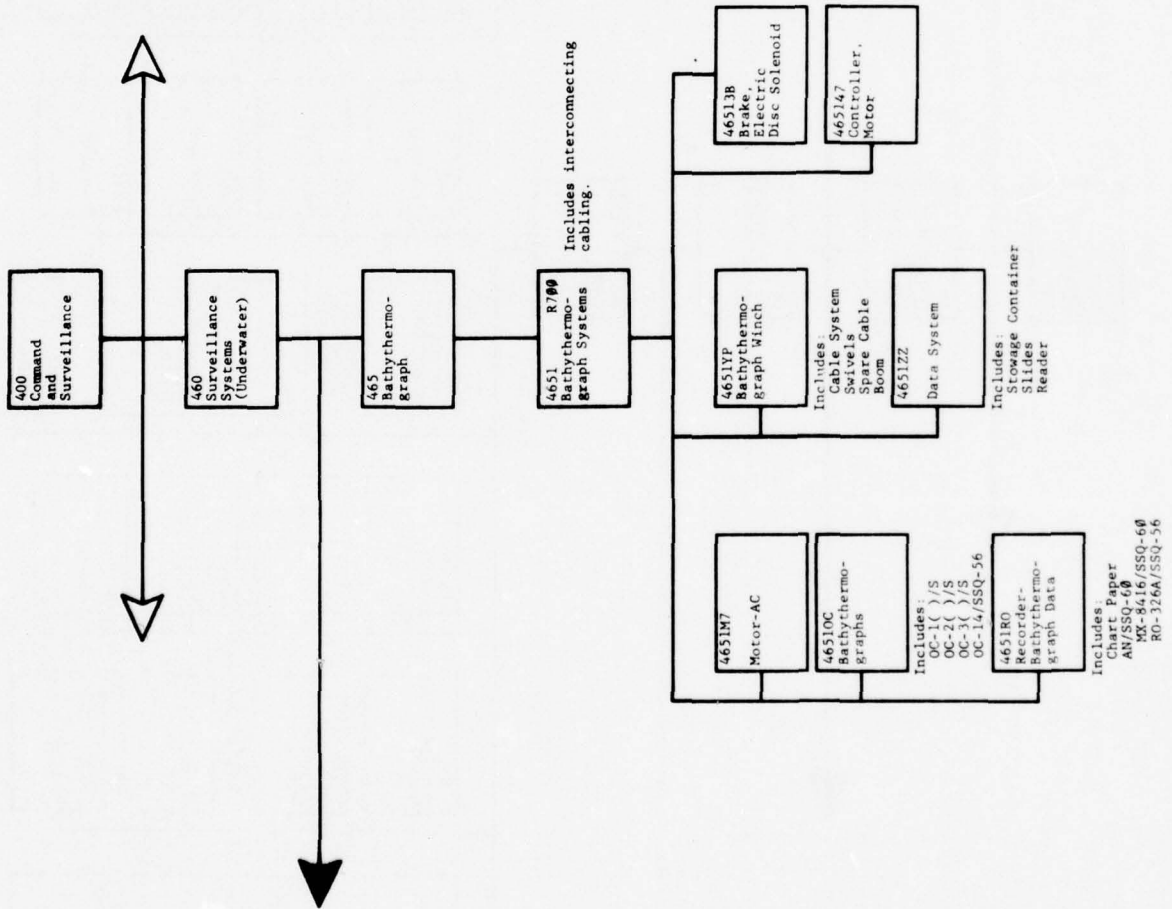

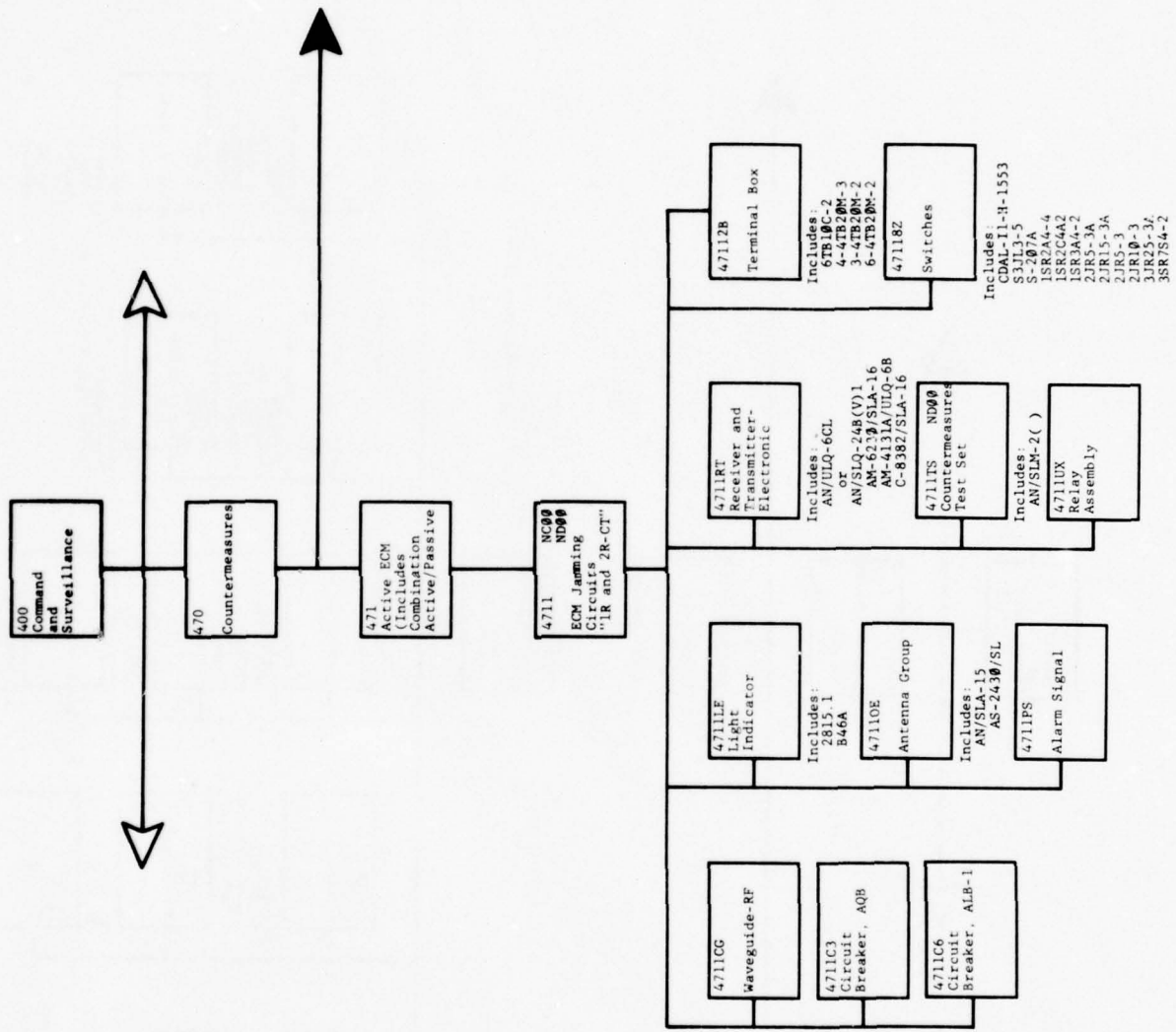

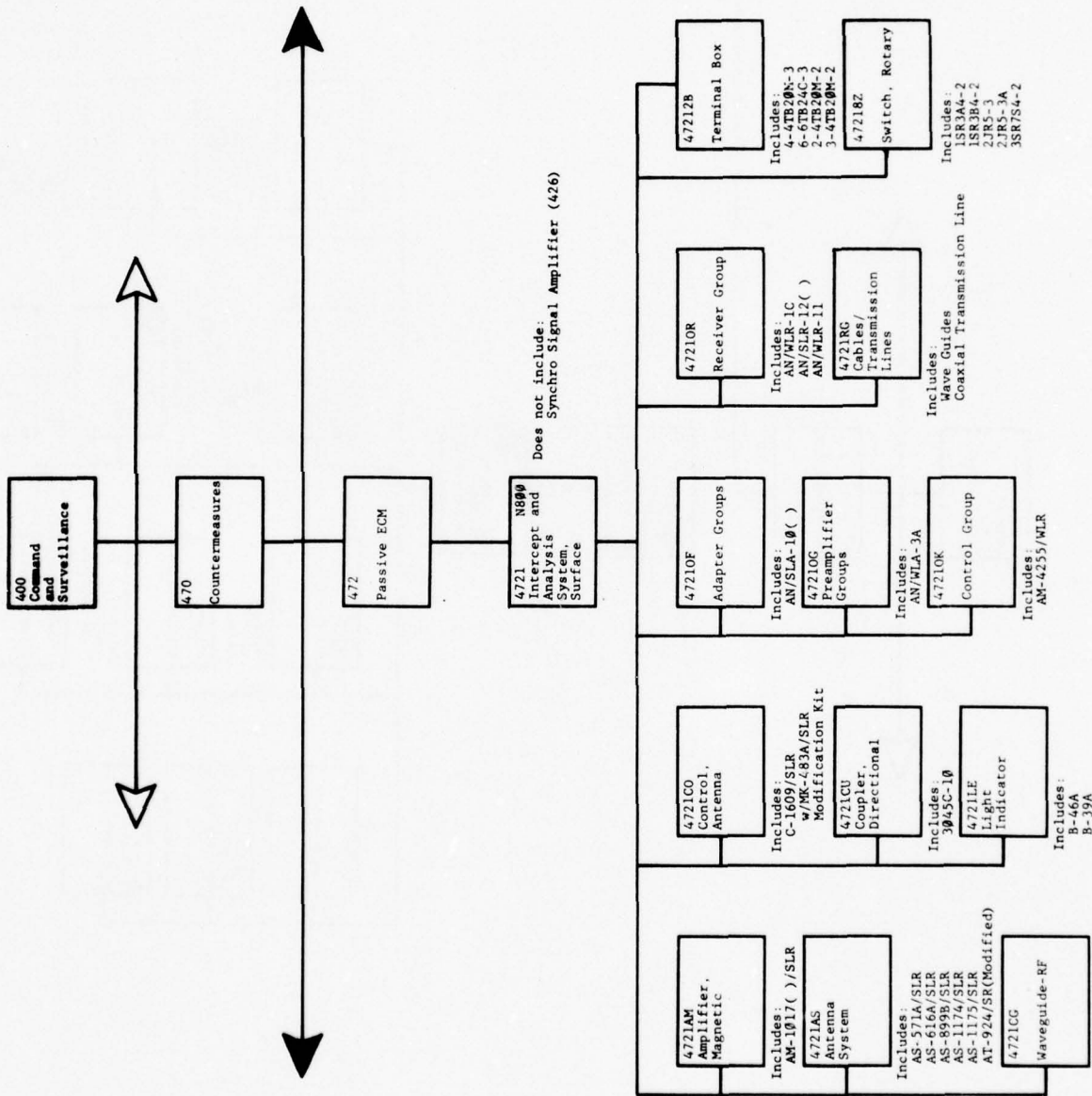

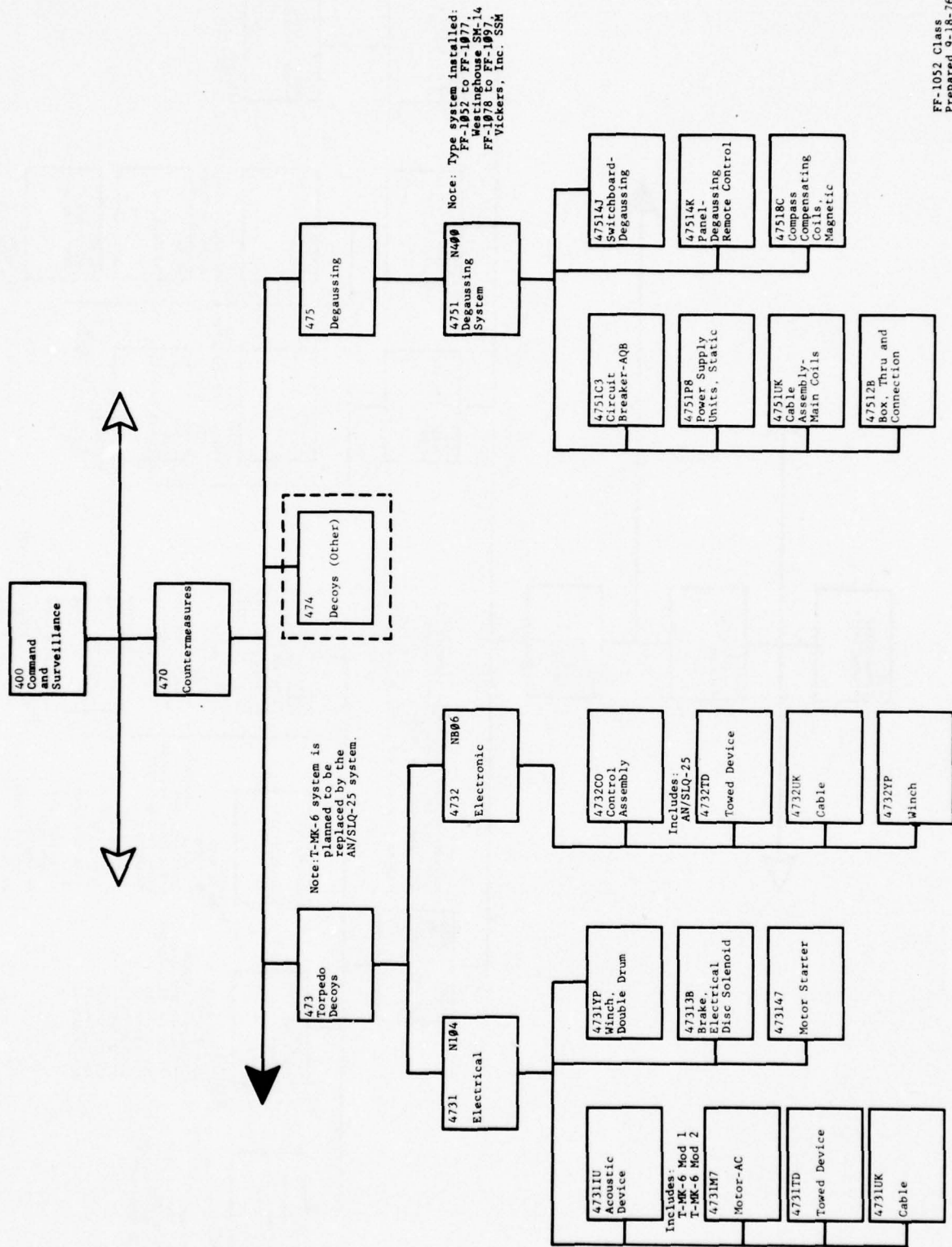

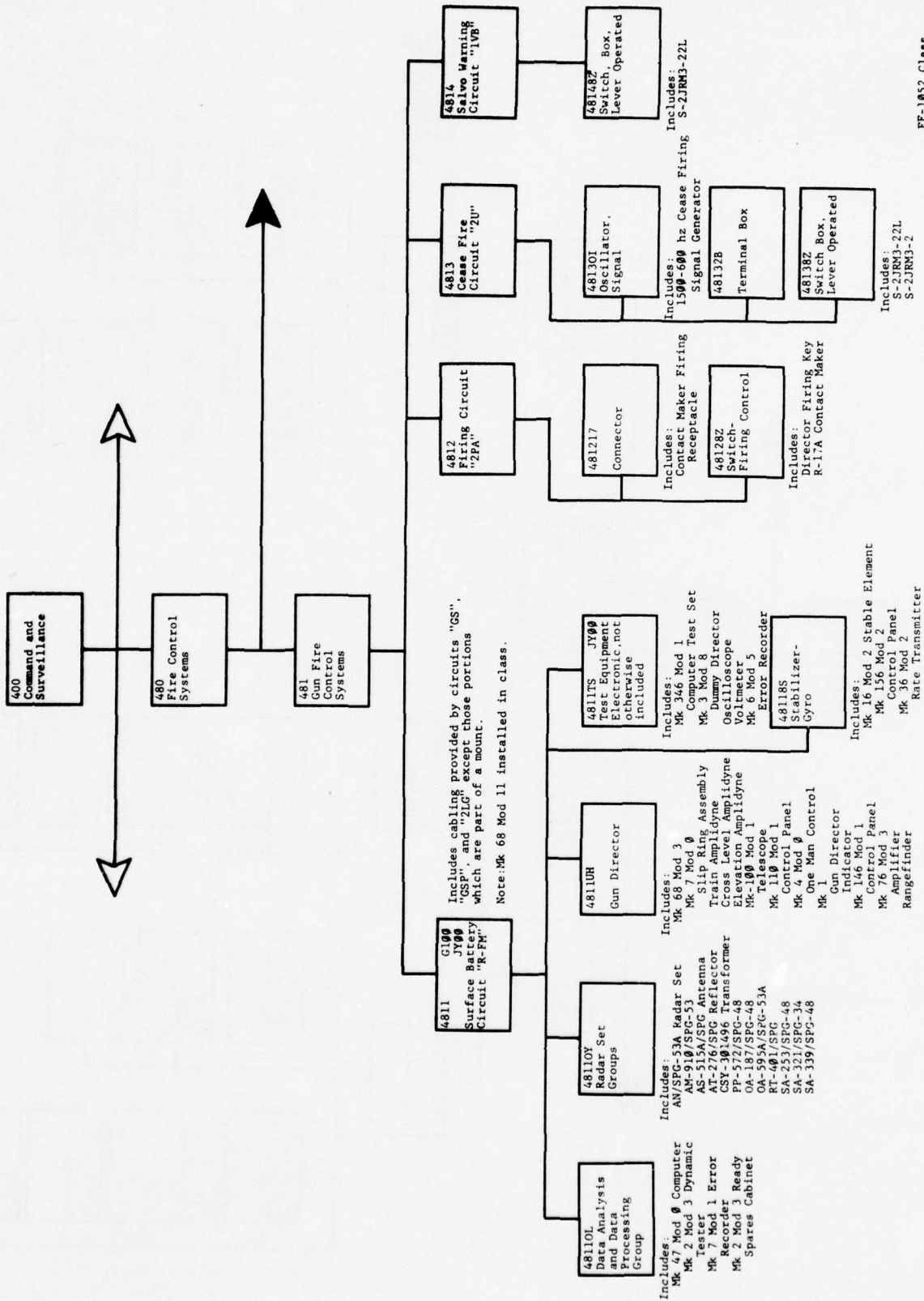

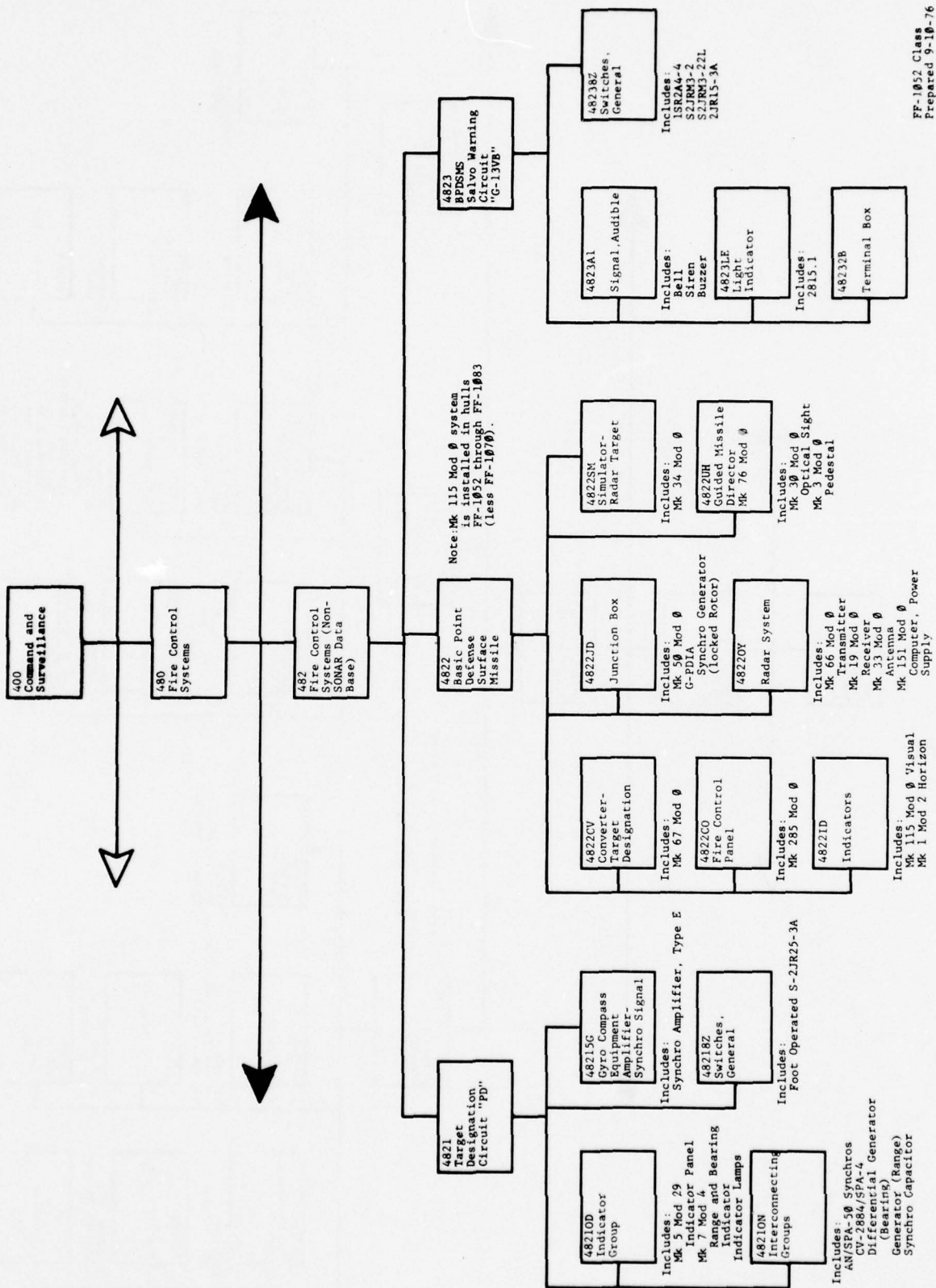

FF-1052 Class  
Prepared 9-10-76

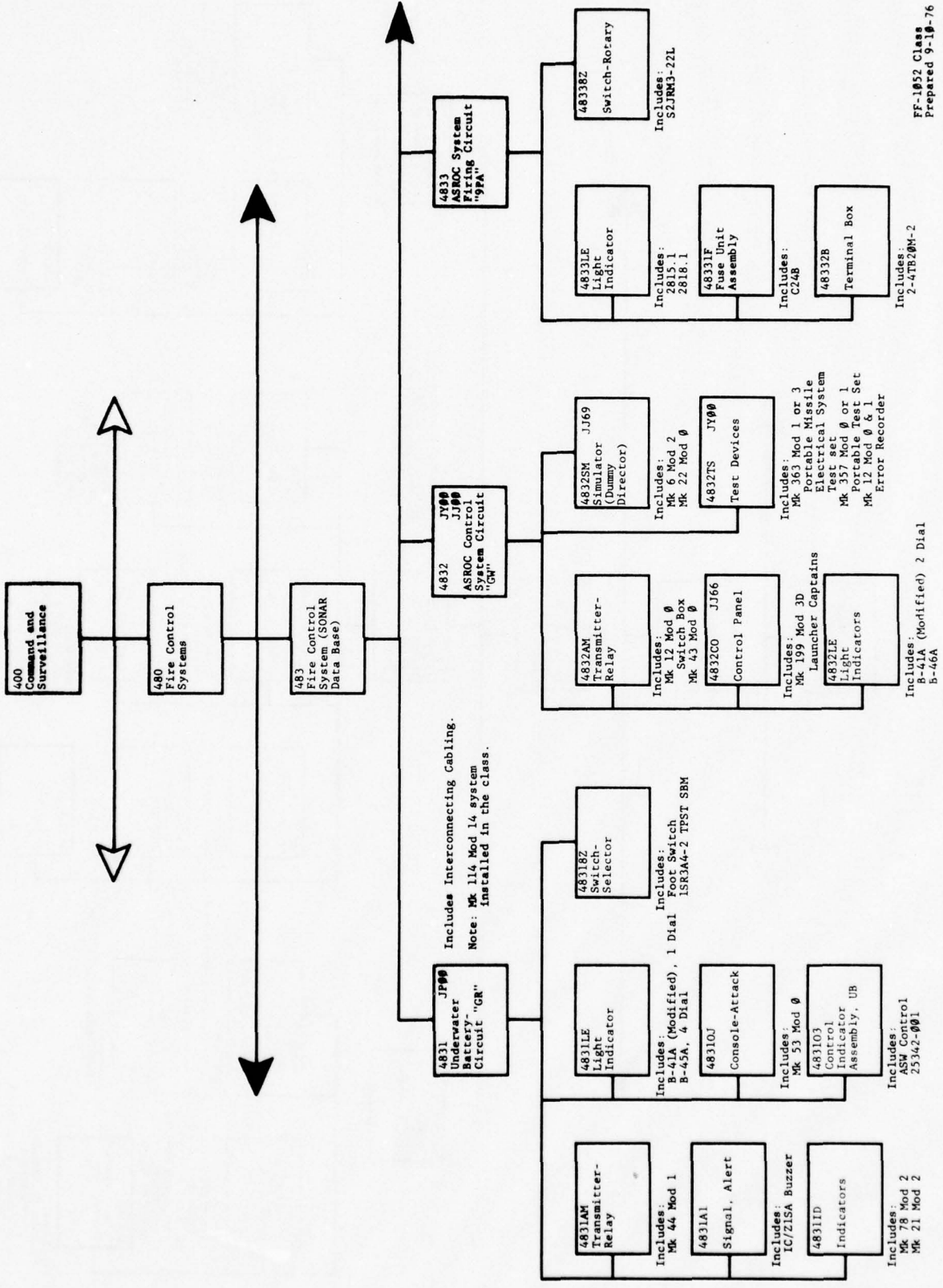

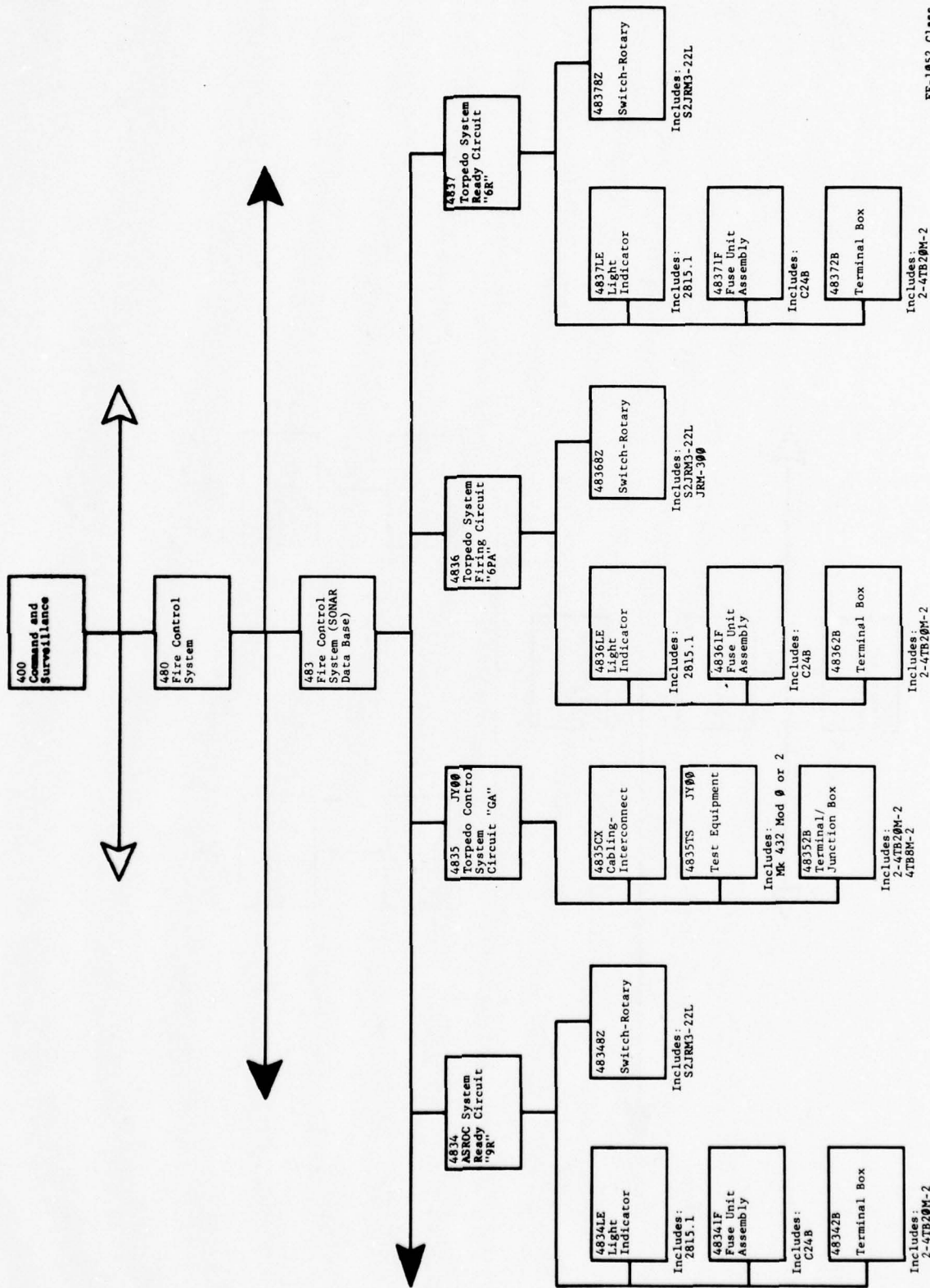

FF-1052 Class  
Prepared 9-10-76

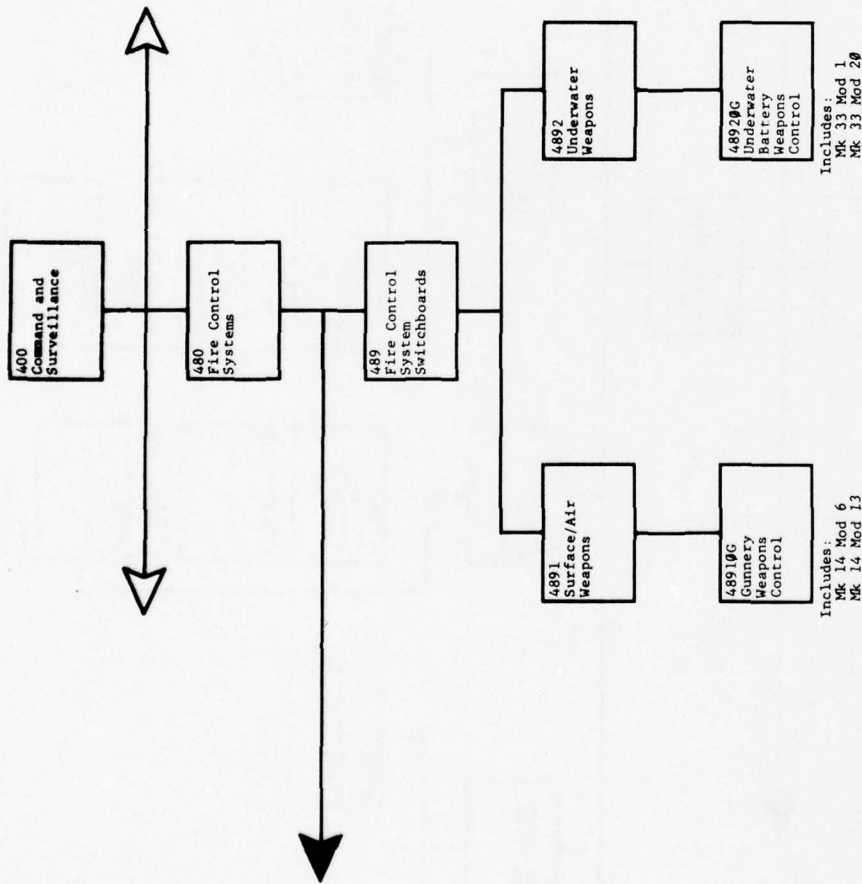

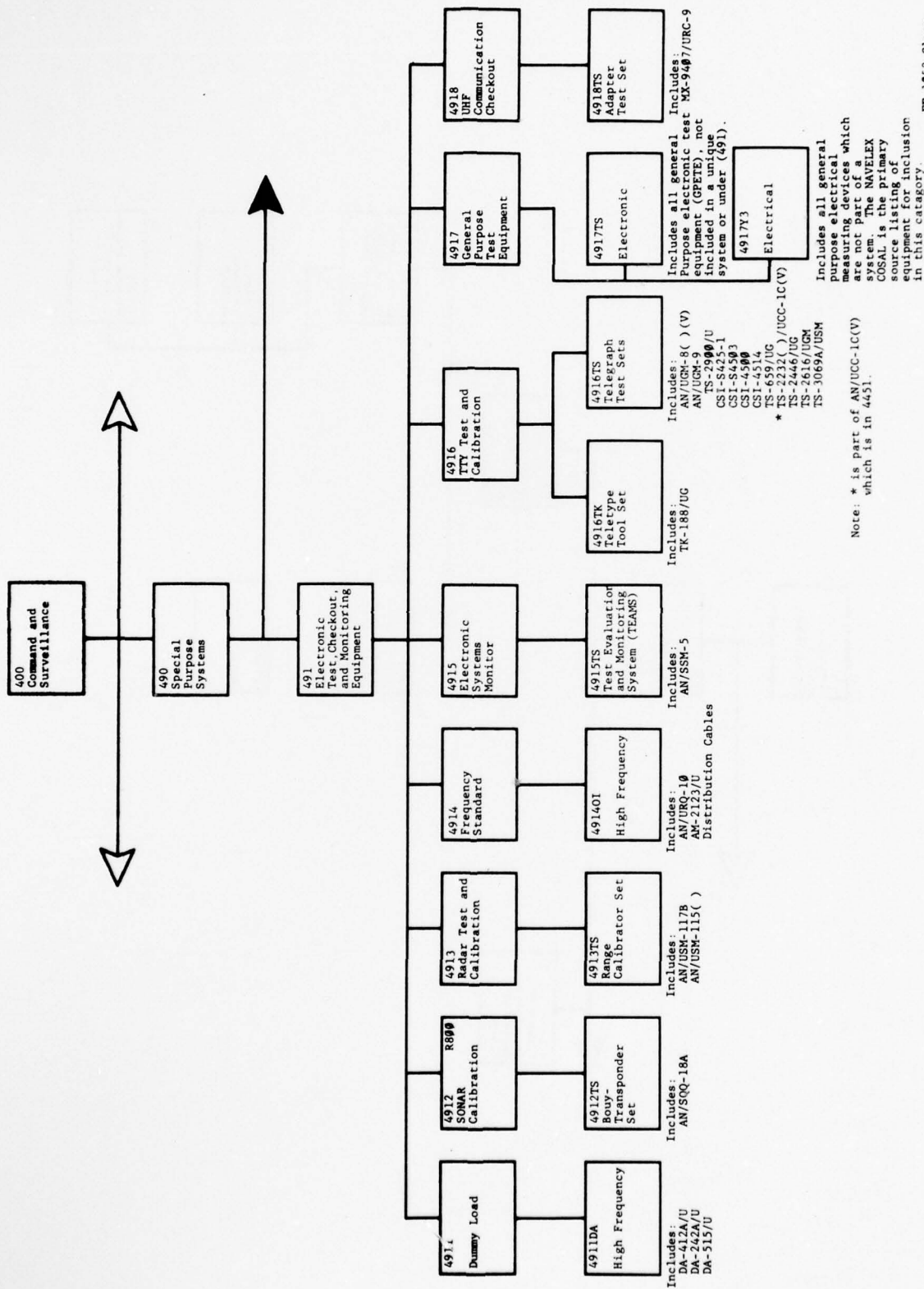

FF-1052 Class  
Prepared 9-10-76

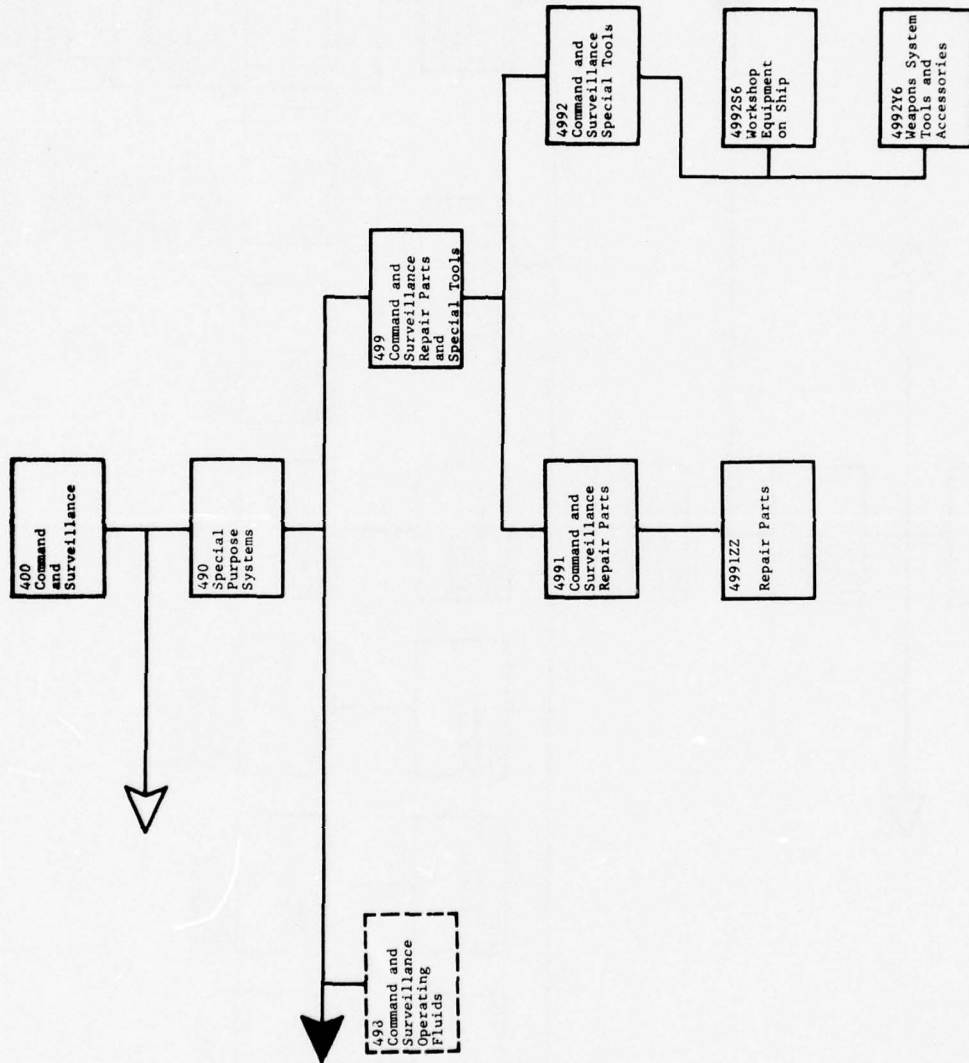

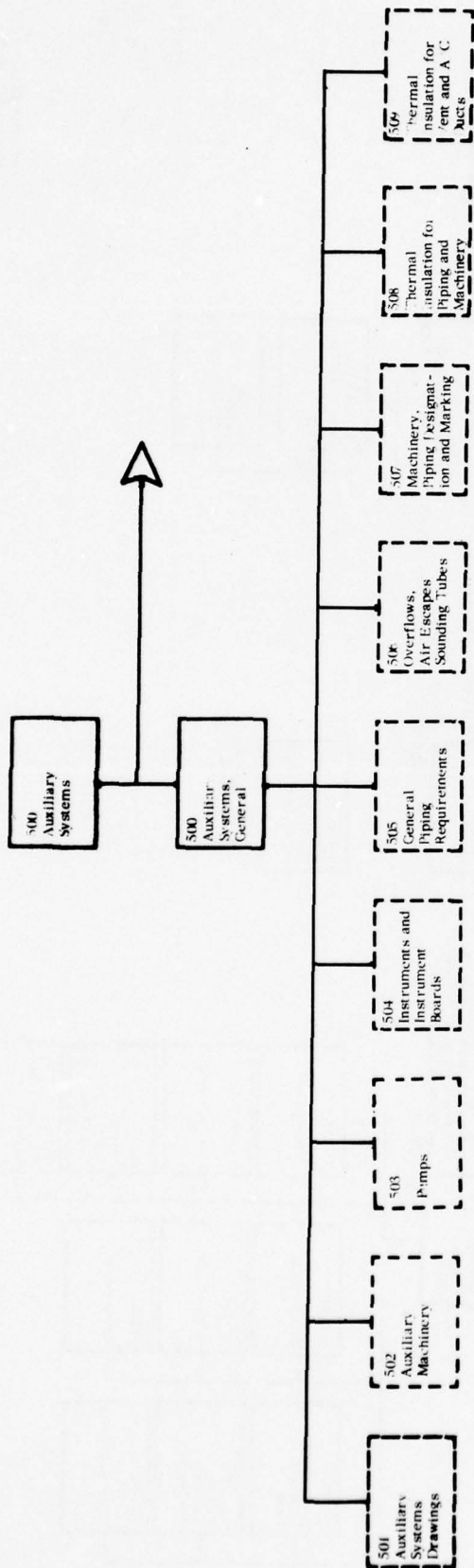

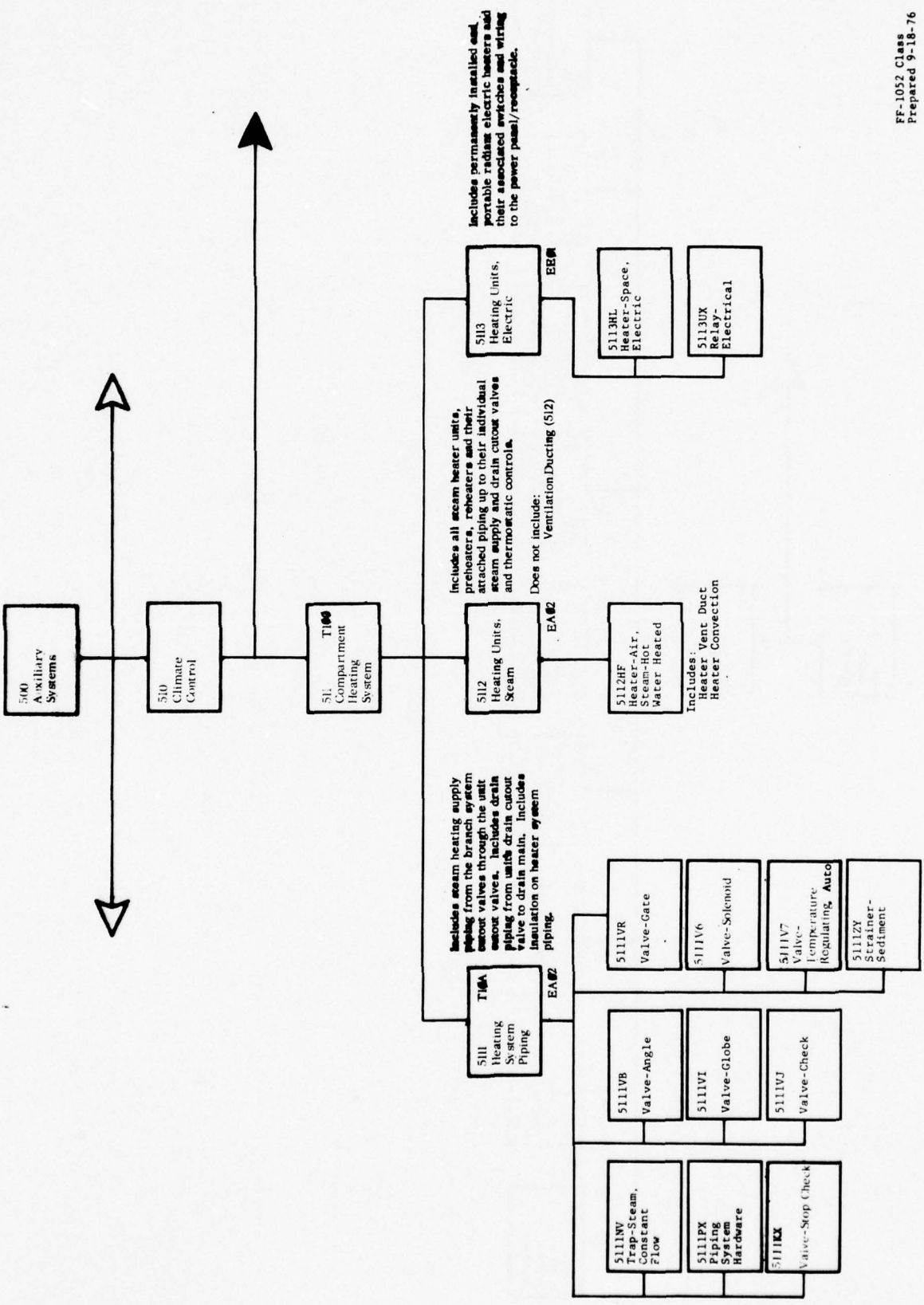

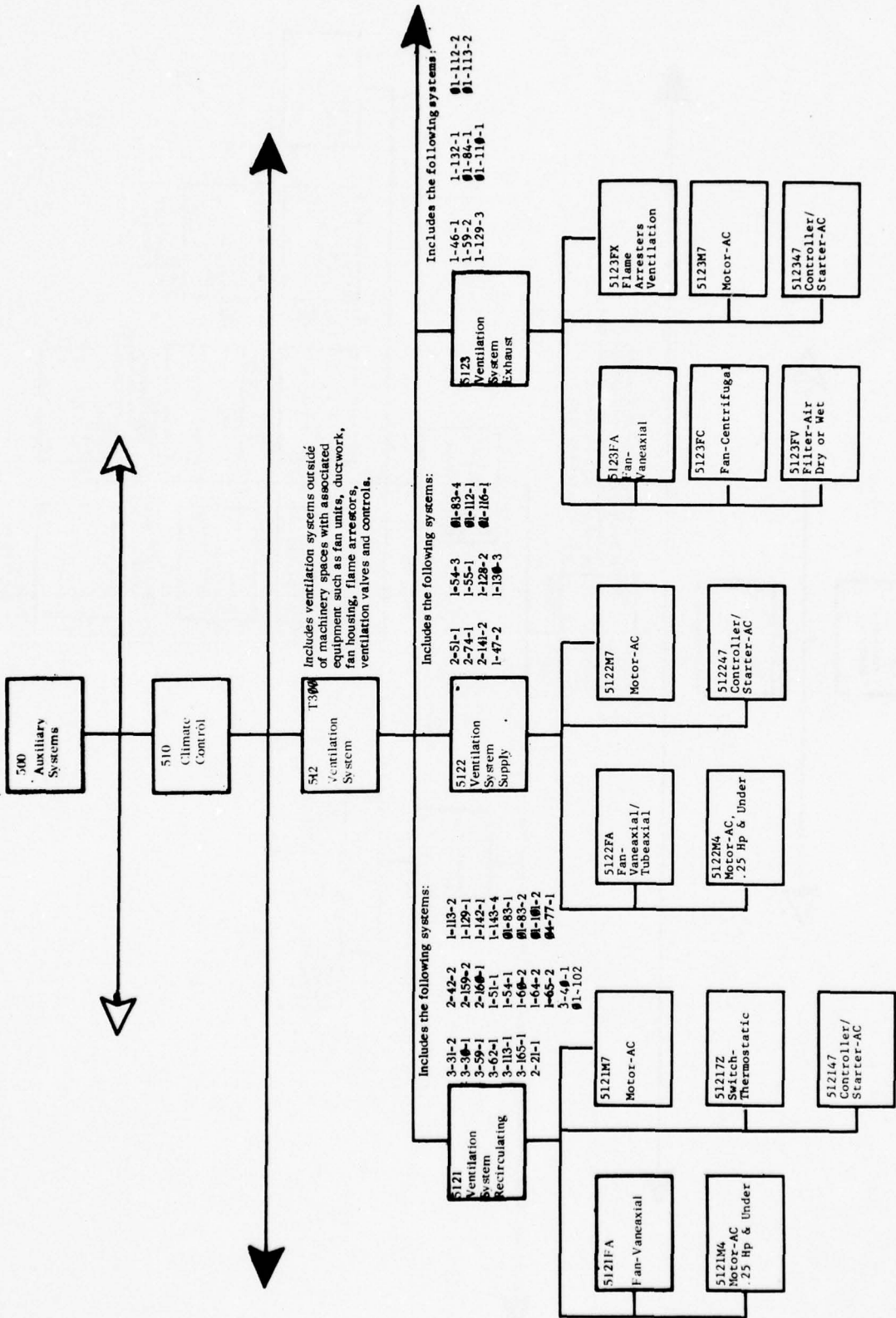

FF-1052 Class  
Prepared 9-18-76

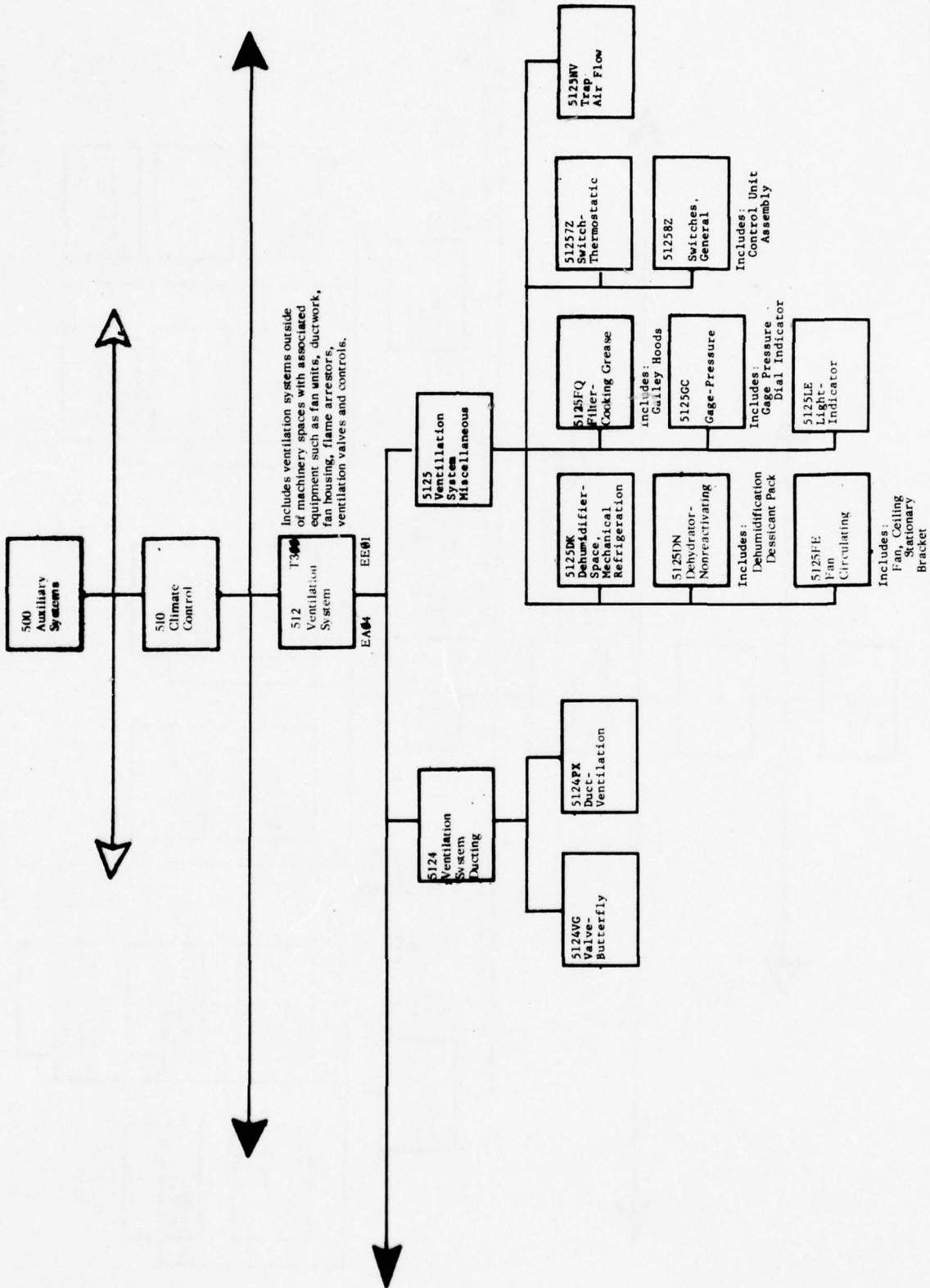

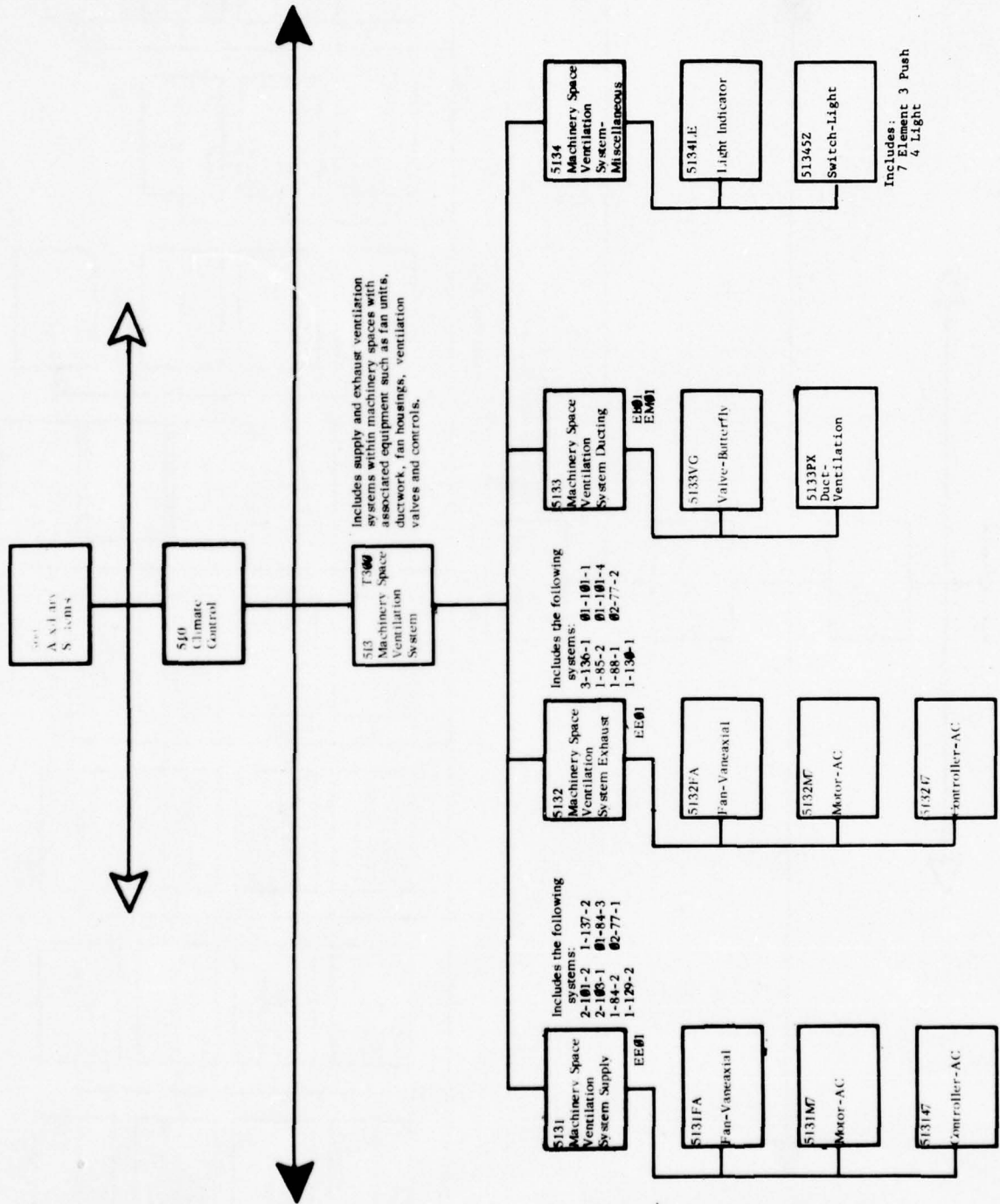

Includes:  
7 Element 3 Push  
4 Light

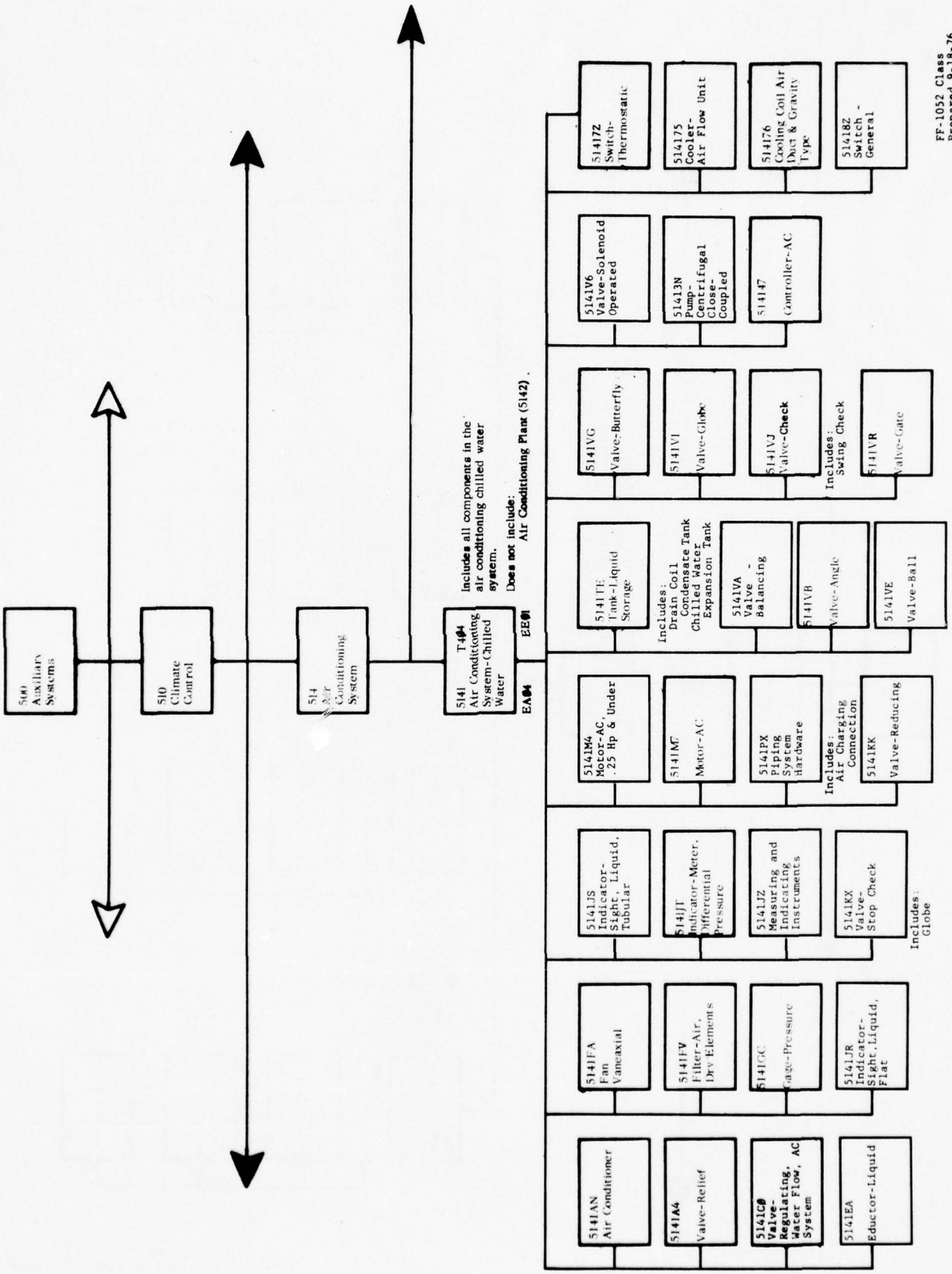

FF-1052 Class  
Prepared 9-18-76

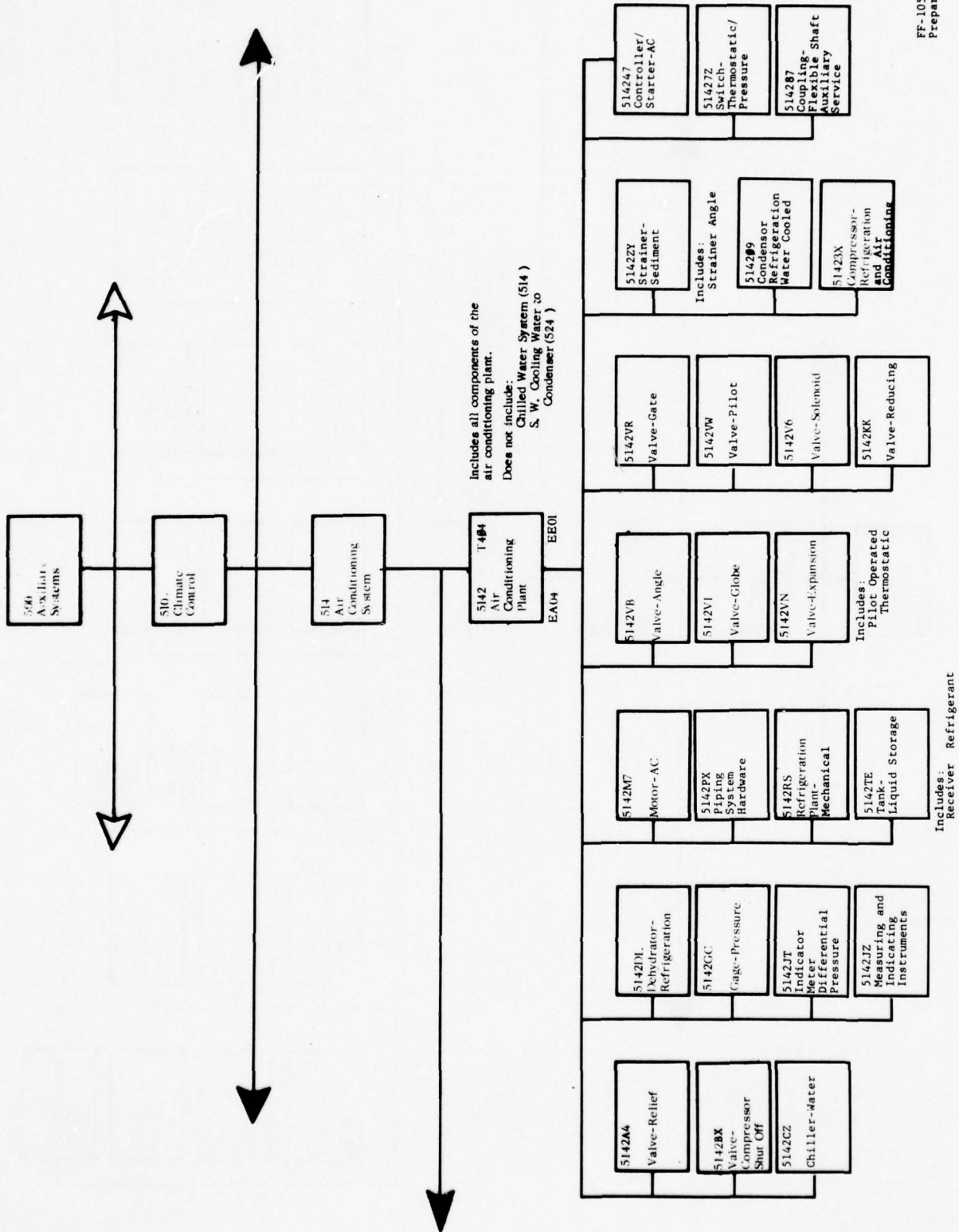

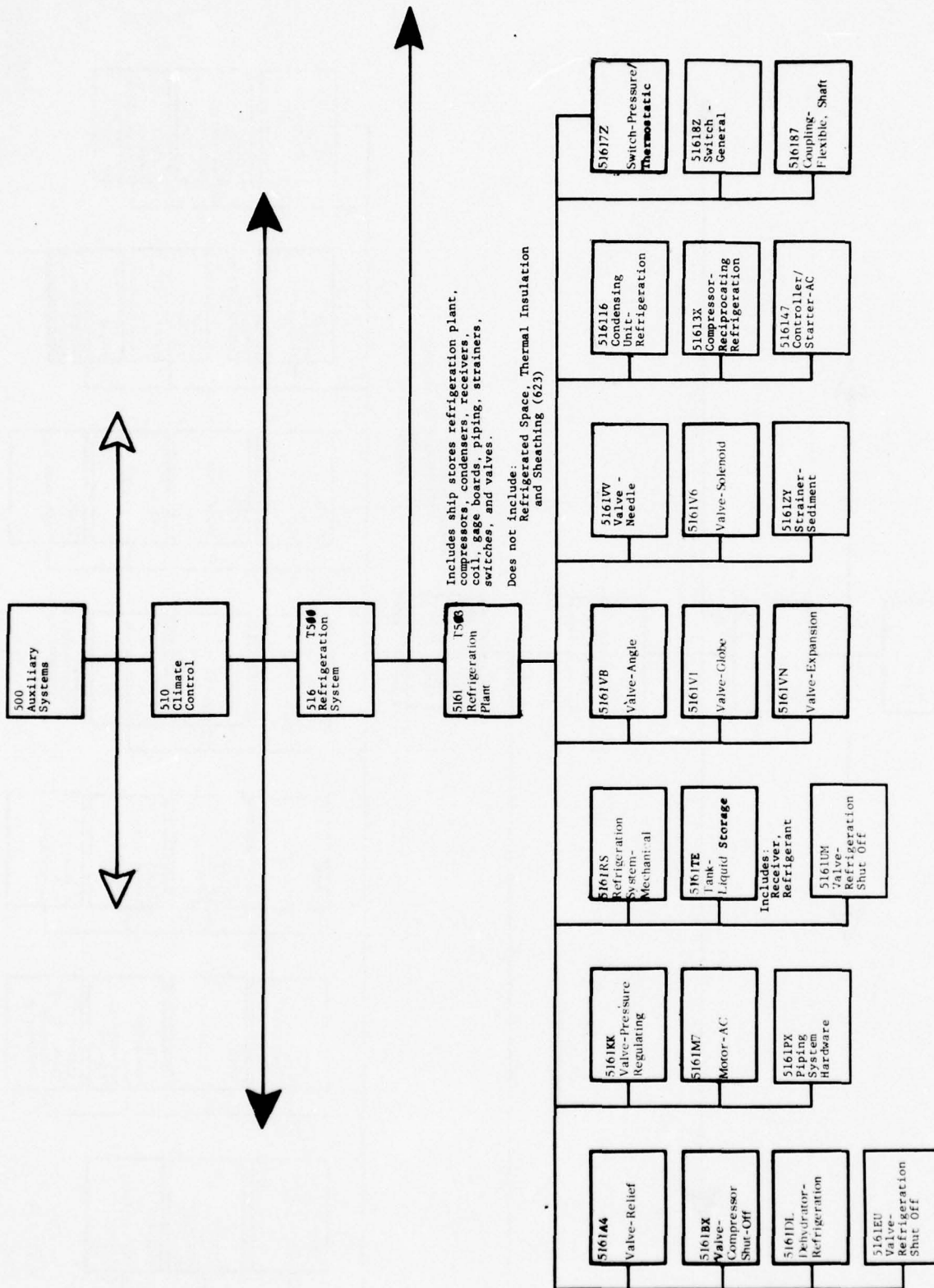



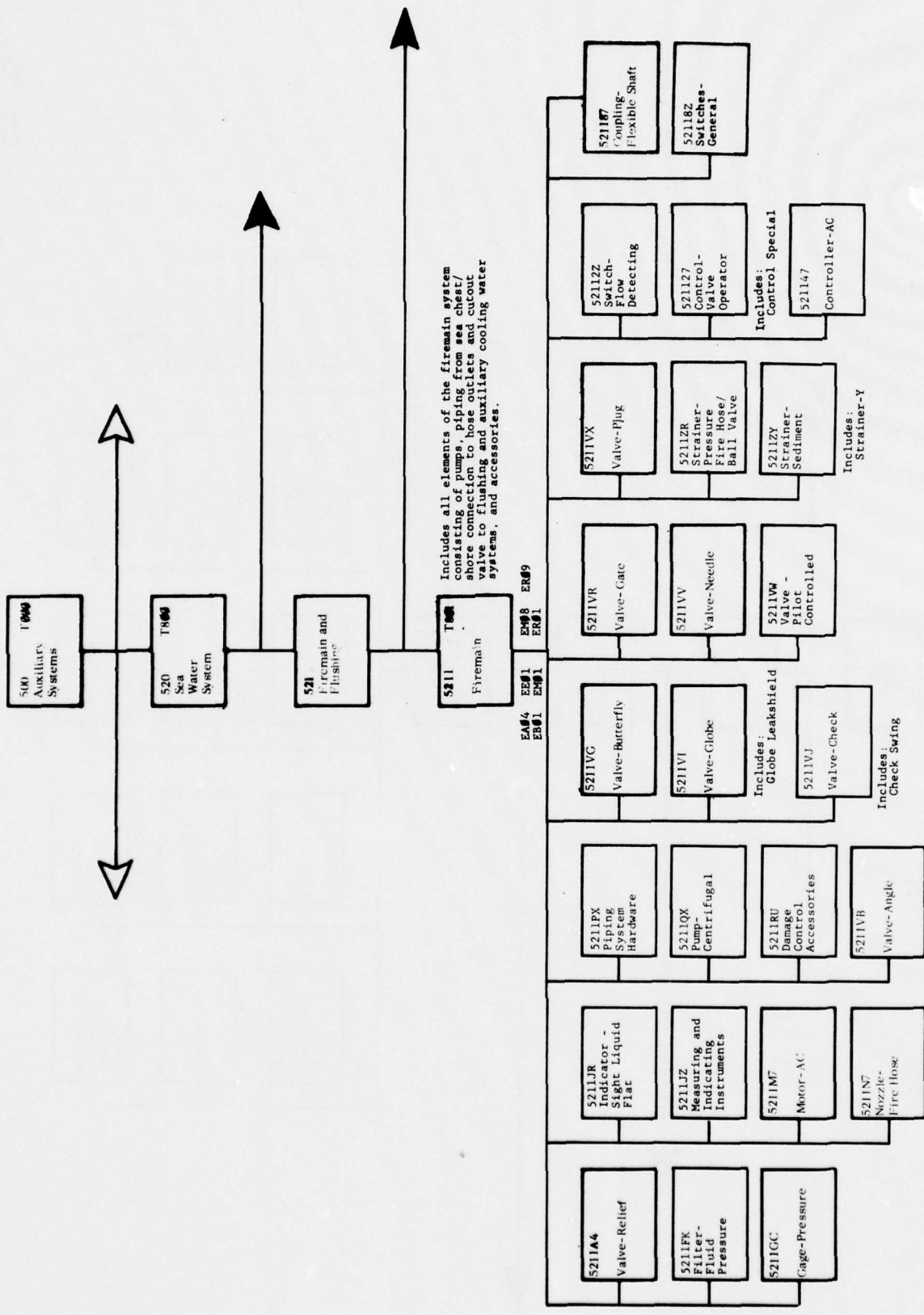

FF-1052 Class  
Prepared 9-18-76

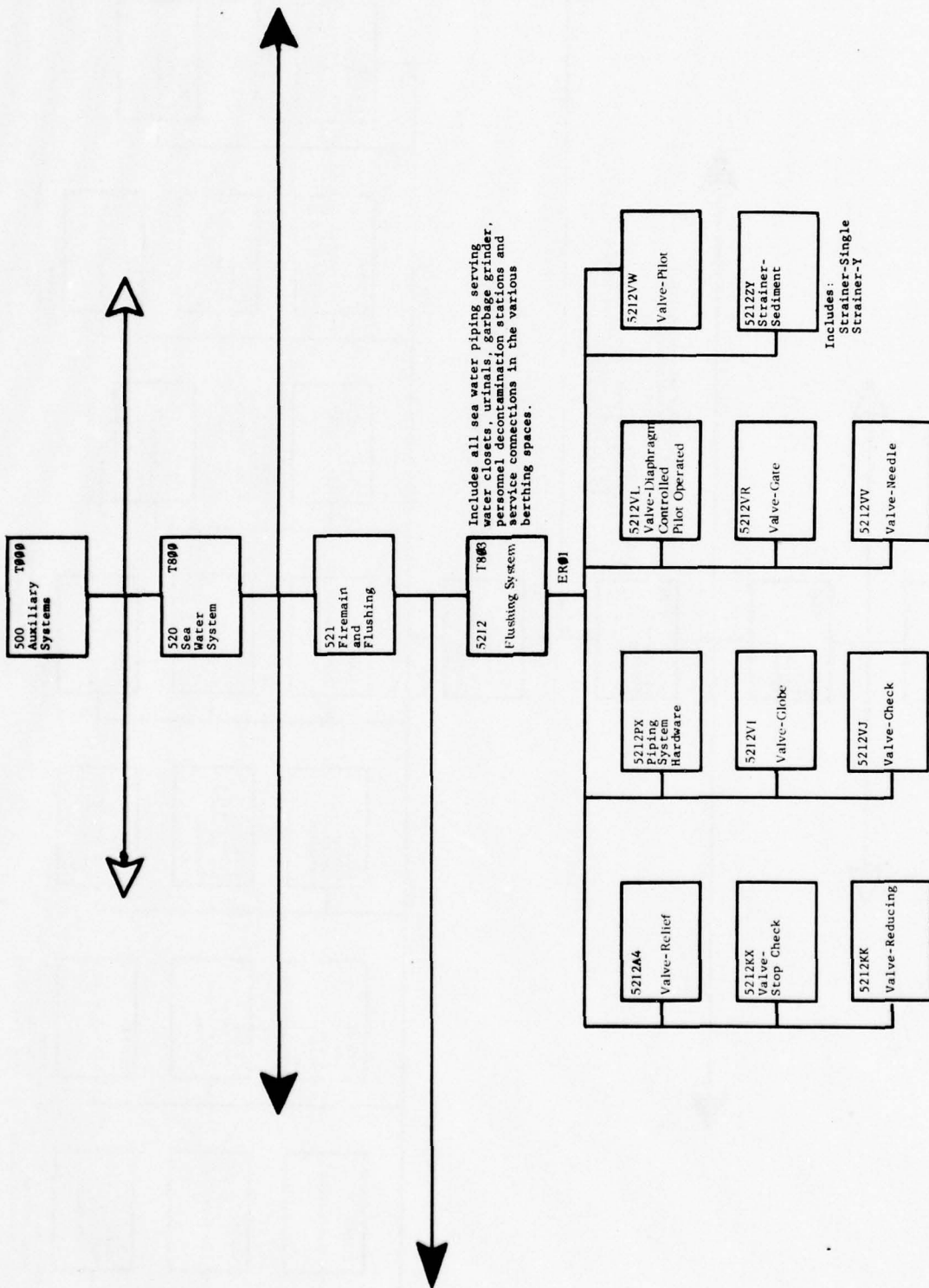

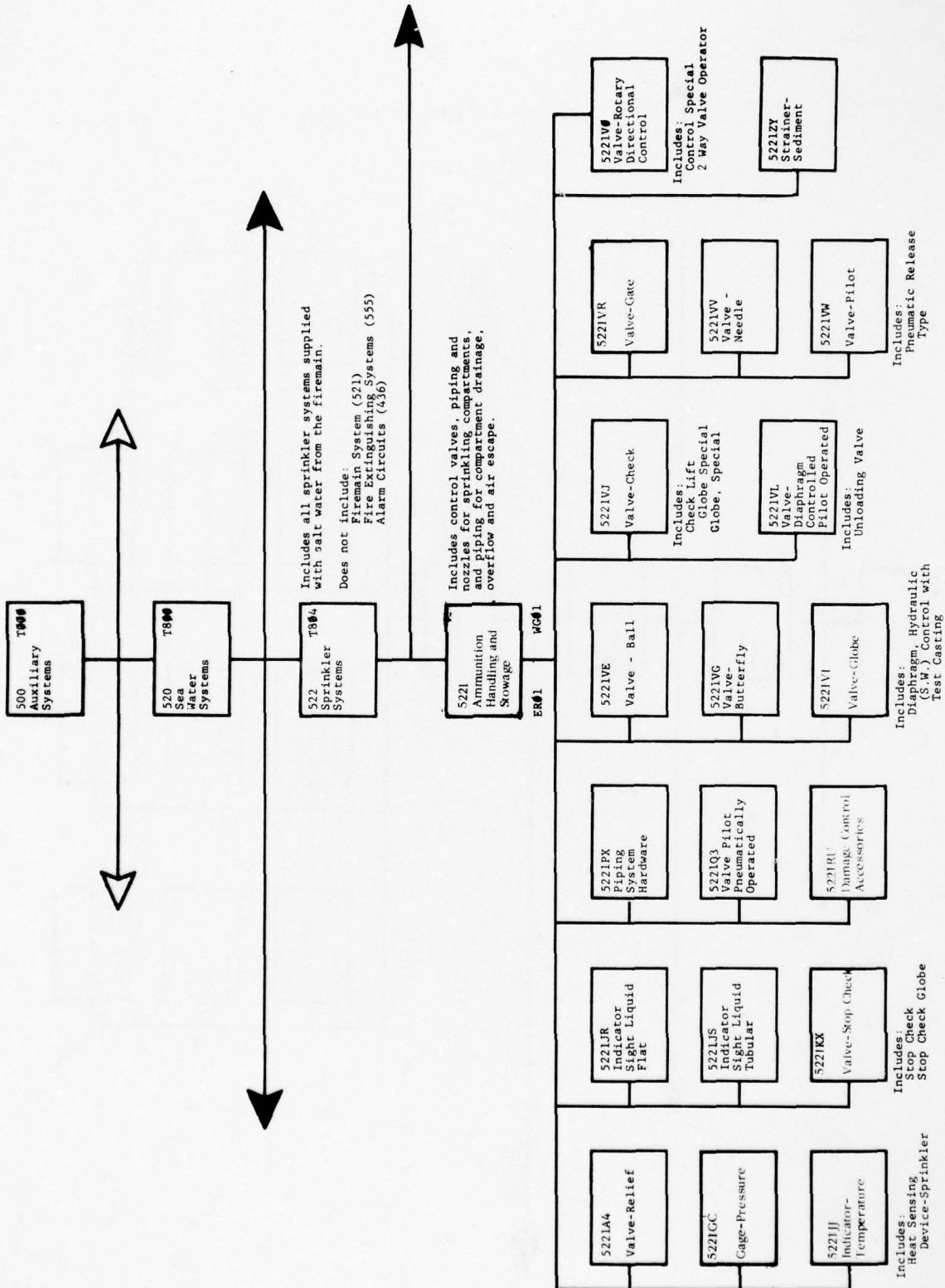

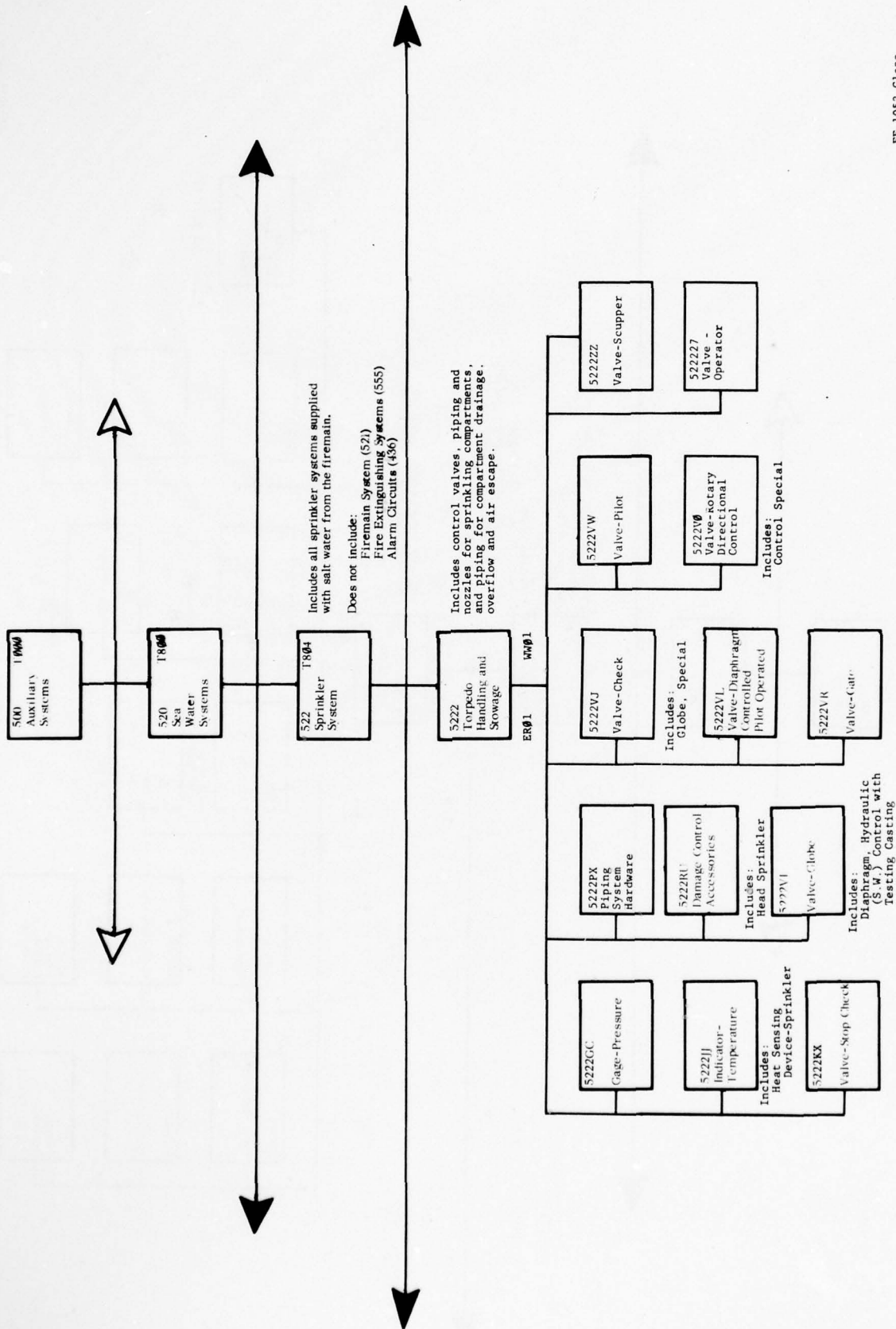

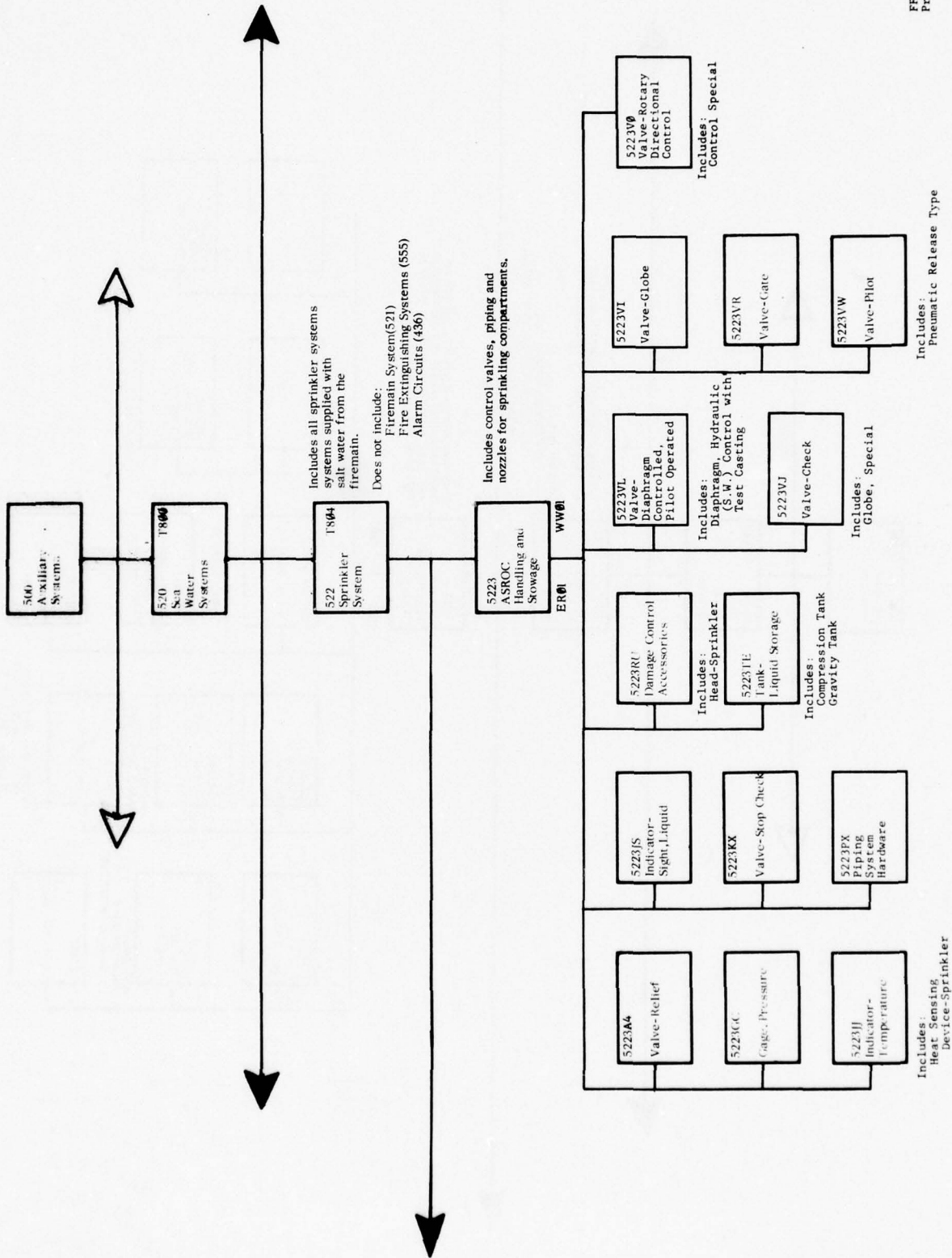

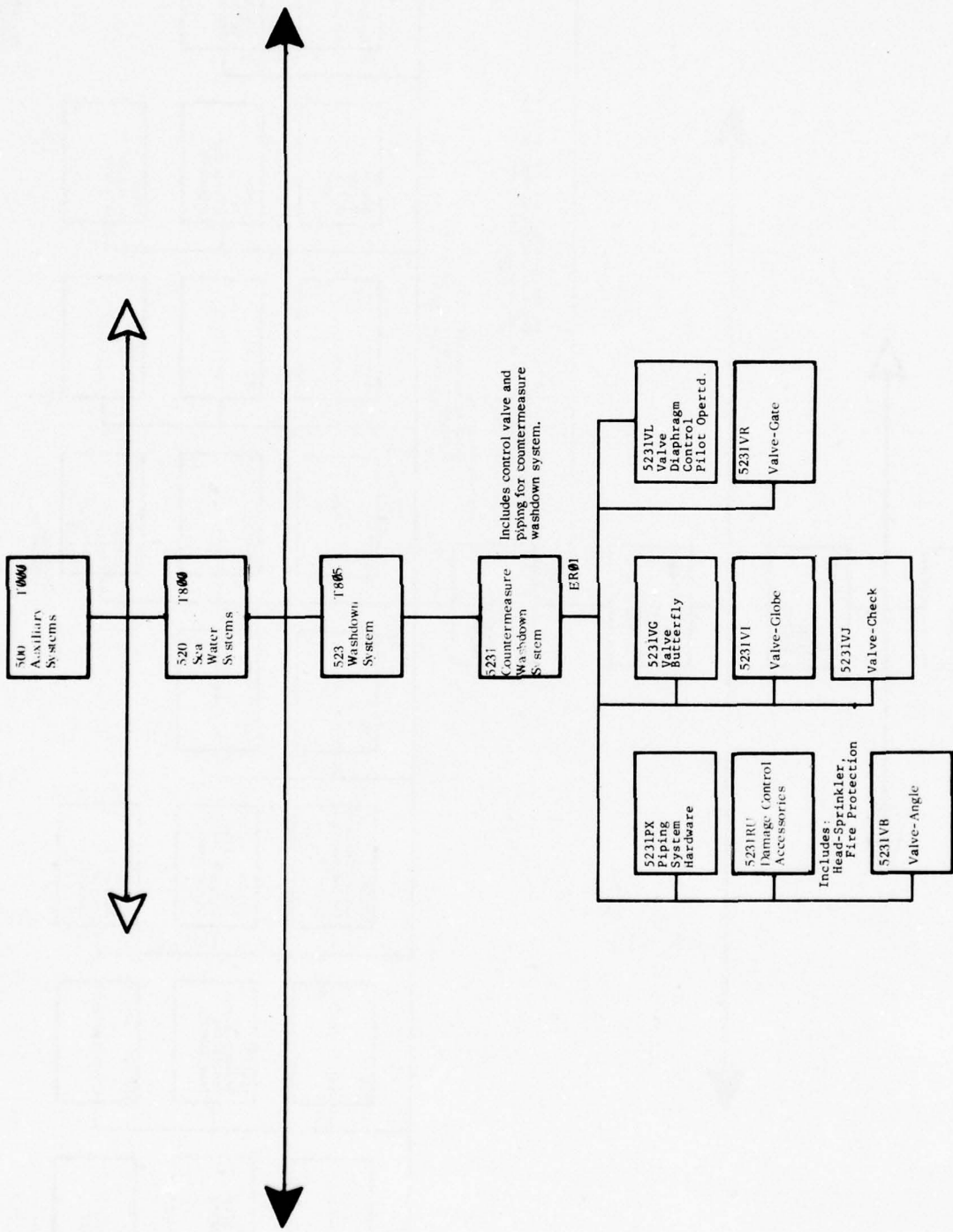

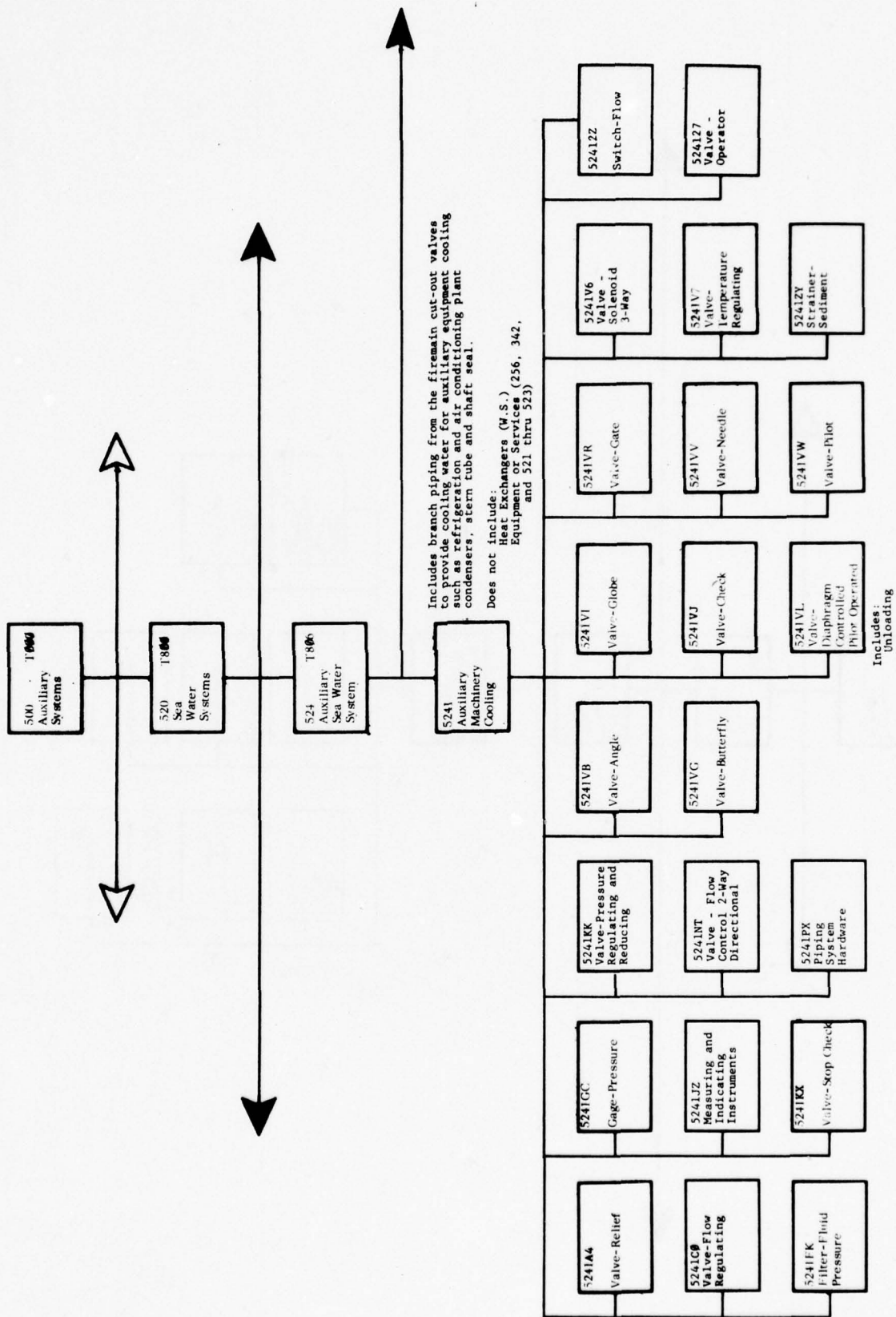

FF-1052 Class  
Prepared 9-18-76

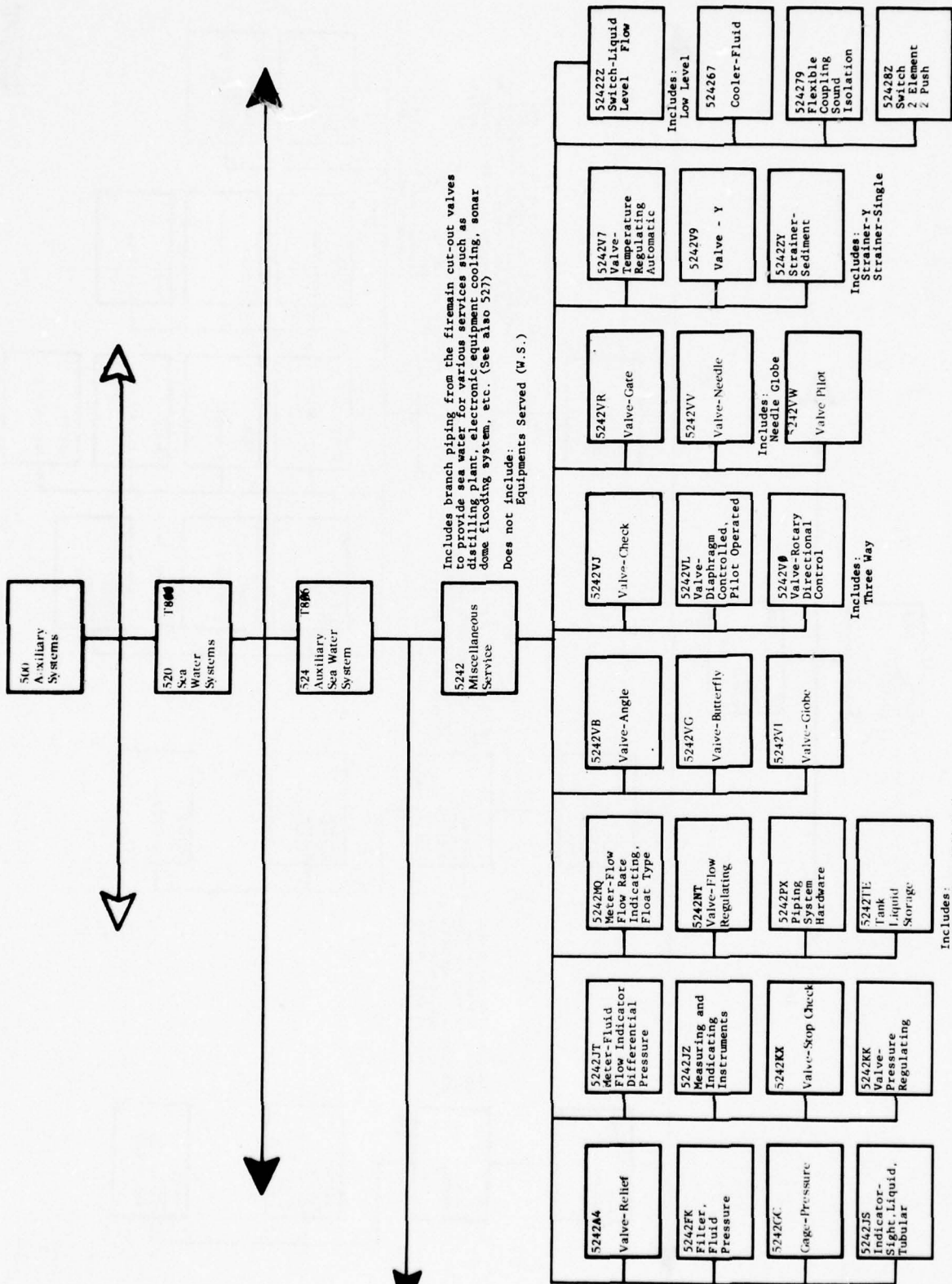

FF-1052 Class  
Prepared 9-18-76

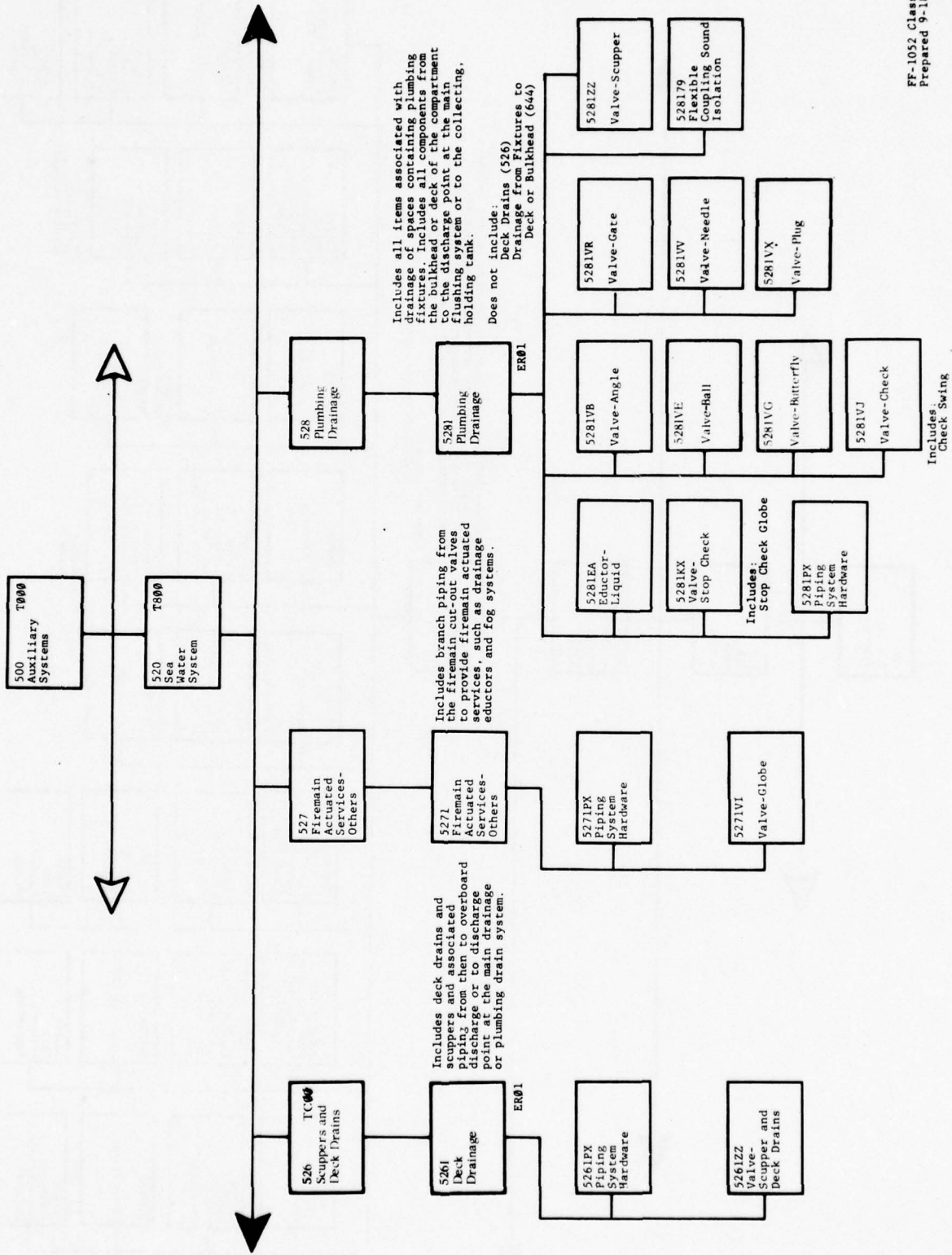

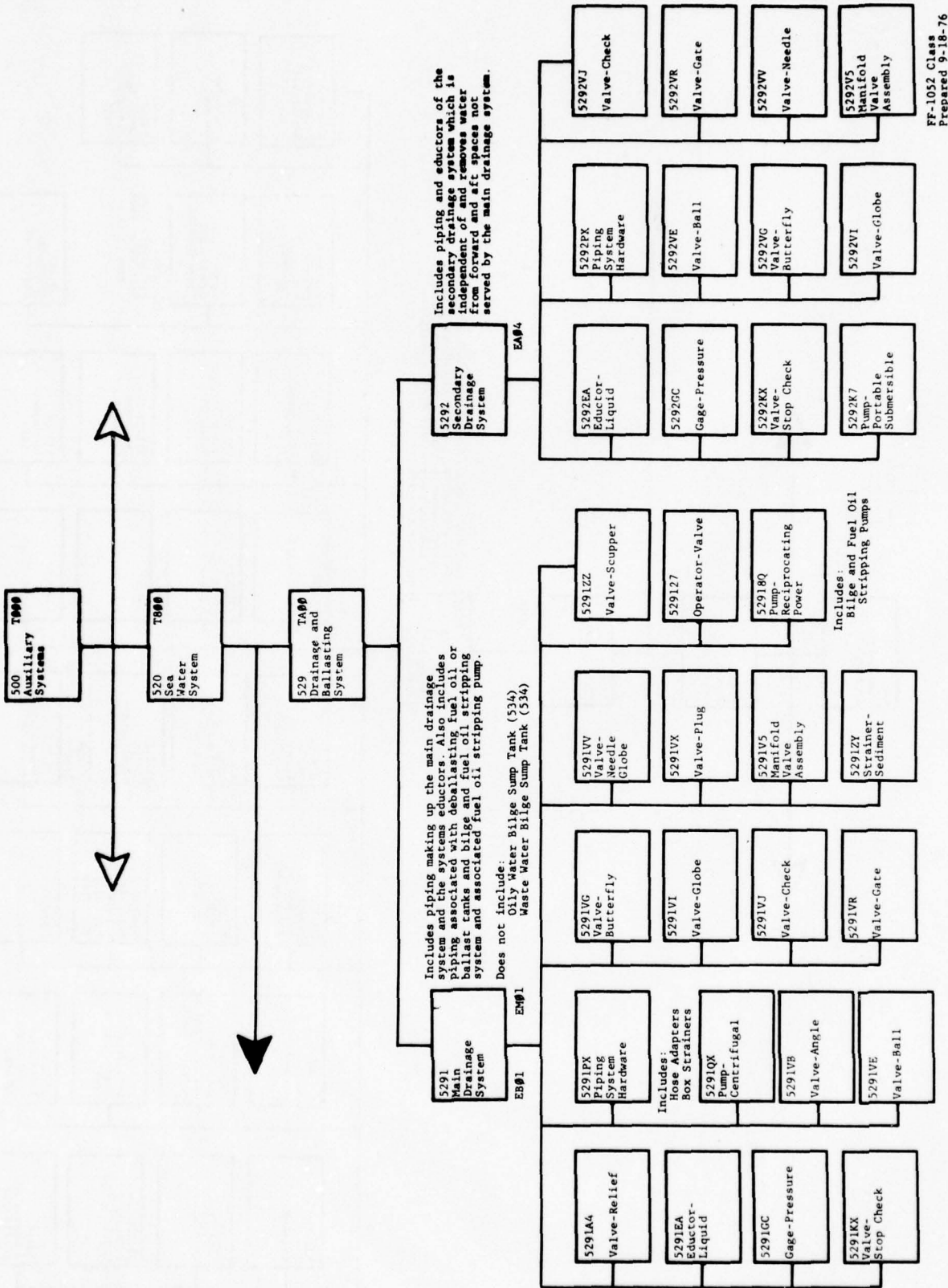

FF-1052 Class  
Prepared 9-18-76

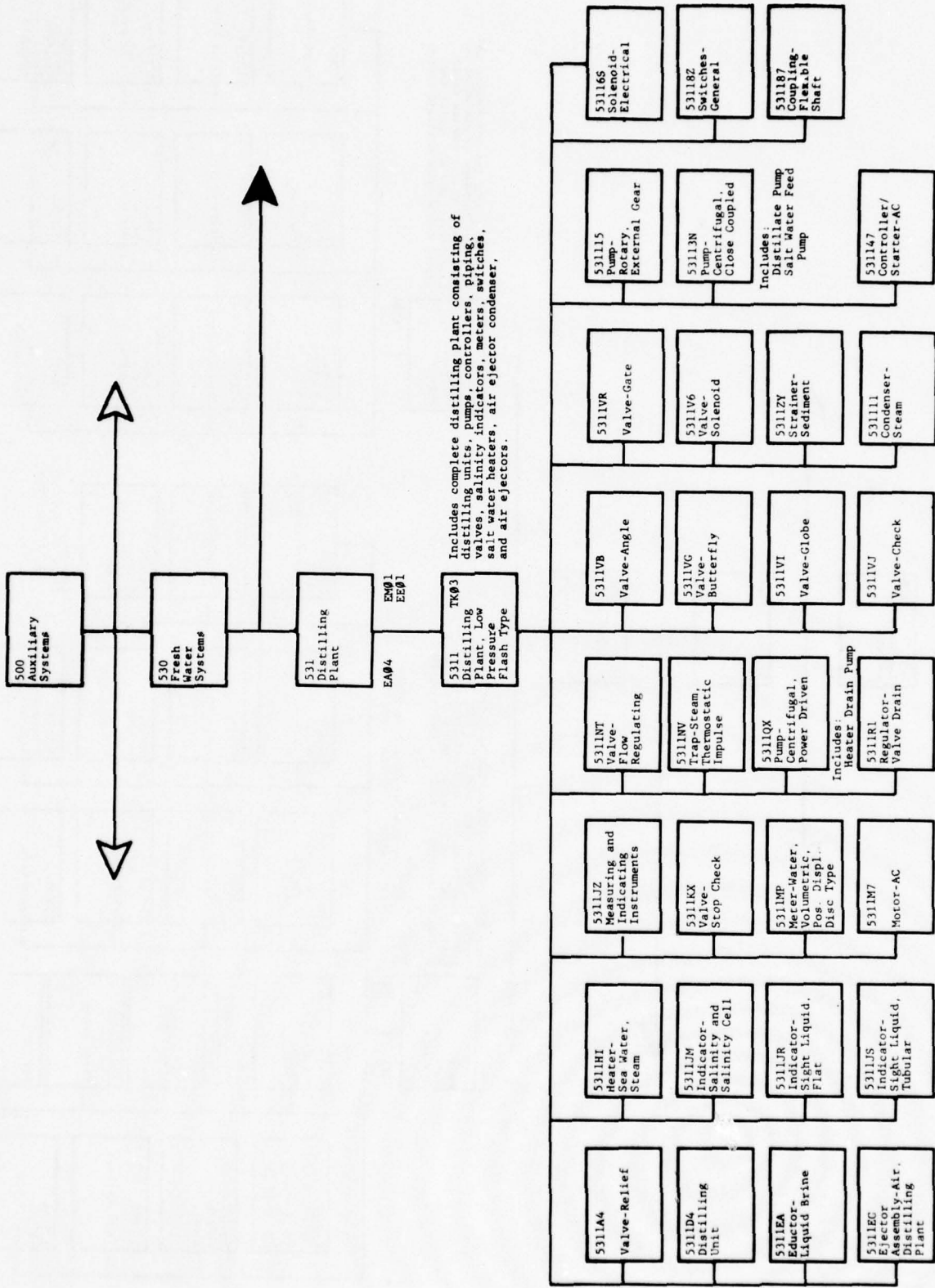



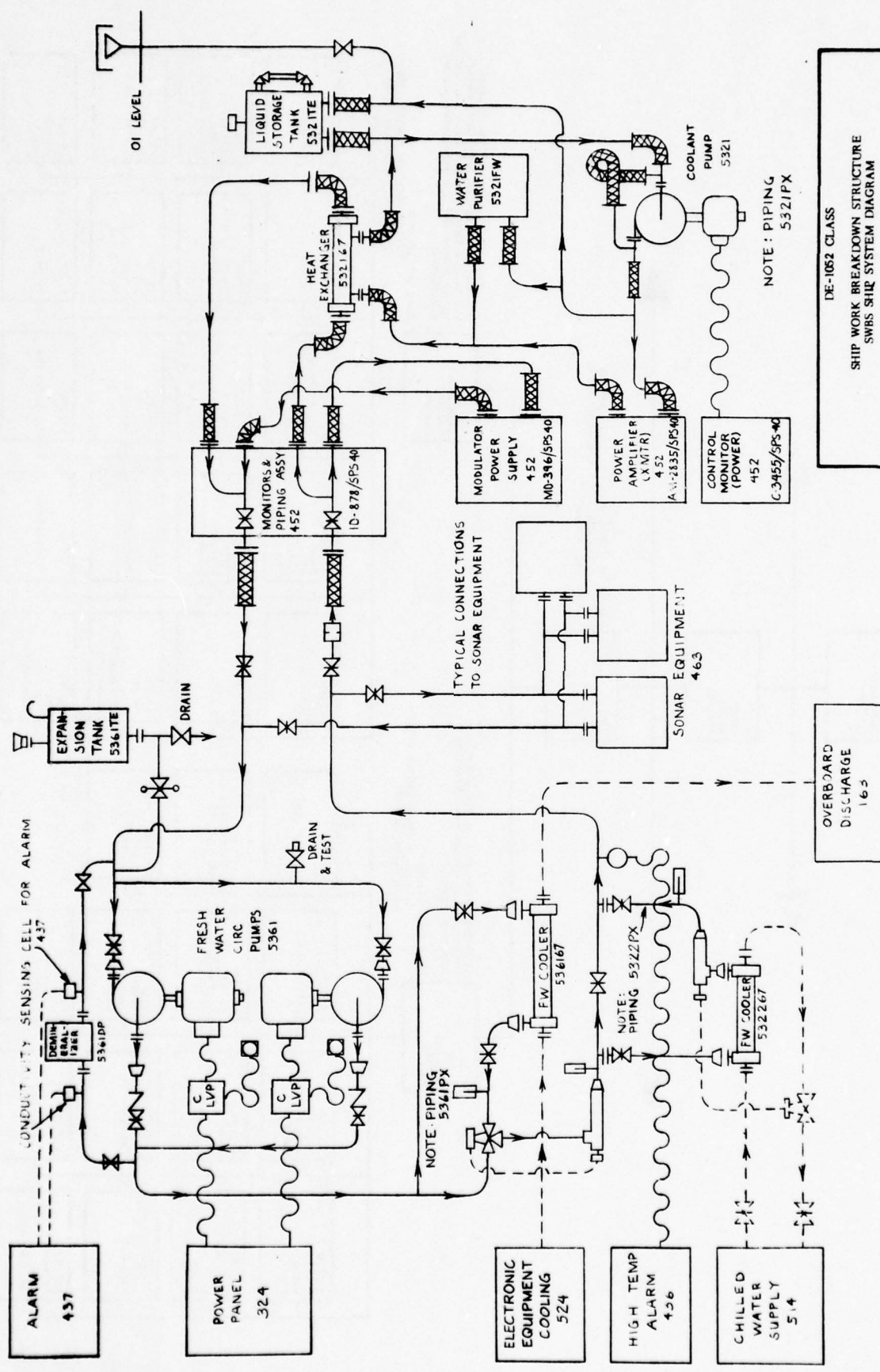

DE-1052 CLASS  
 SHIP WORK BREAKDOWN STRUCTURE  
 SWBS SHIP SYSTEM DIAGRAM  
 500 AUXILIARY SYSTEMS  
 530 FRESH WATER SYSTEMS  
 532 & 536 RADAR AND SONAR COOLING

NOTE: PIPING 5321PX

OVERBOARD DISCHARGE 163

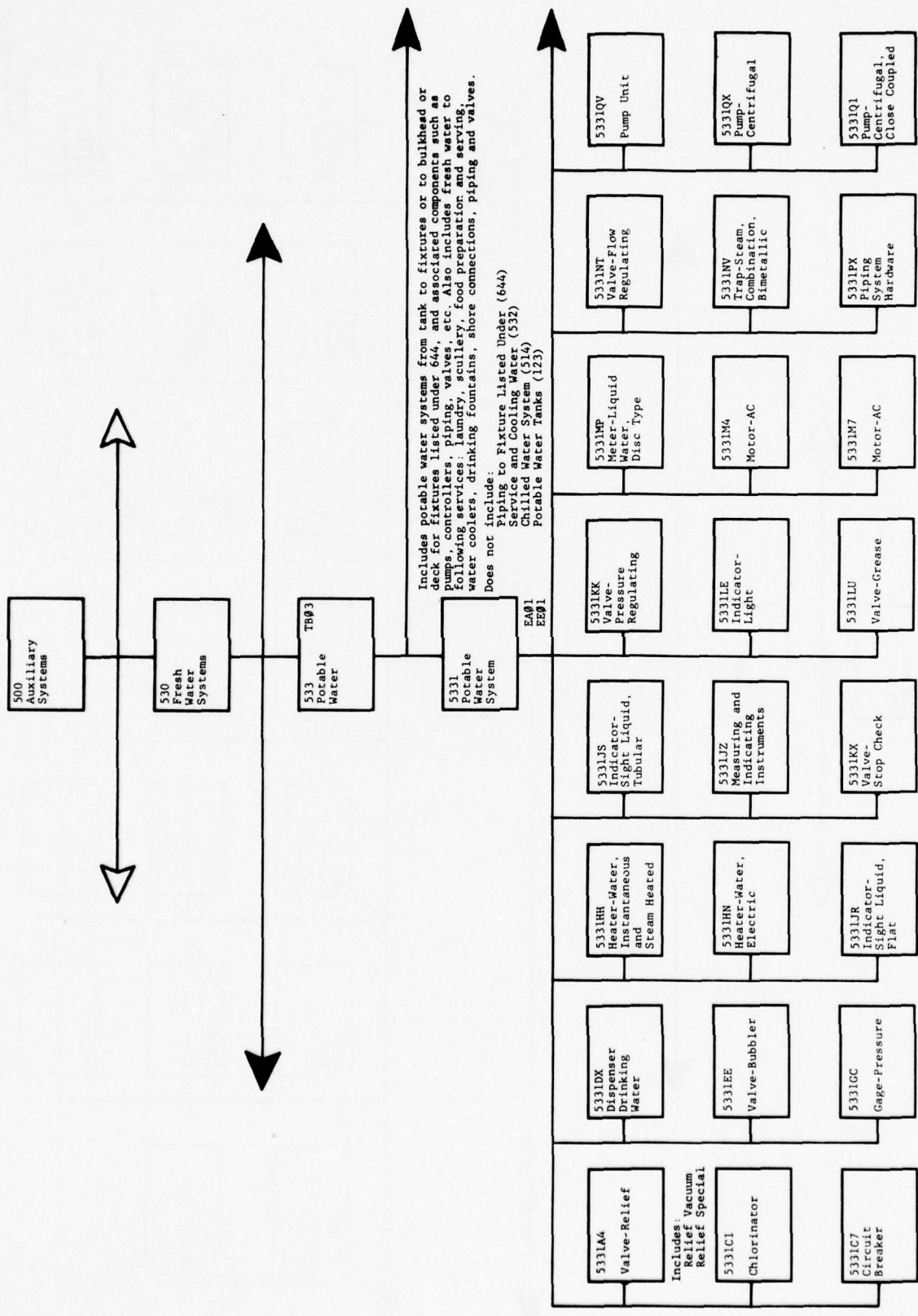

Includes potable water systems from tank to fixtures or to bulkhead or deck for fixtures listed under 644, and associated components such as pumps, controllers, piping, valves, etc. Also includes fresh water to flowing services, pumps, fans, elevators, food service, water coolers, drinking fountains, shore connections, piping and valves.

Does not include:  
Piping to Fixture Listed Under (644)  
Service and Cooling Water System (532)  
Shilled Water System (514)  
Potable Water Tanks (123)

FF-1052 Class  
Prepared 9-18-76

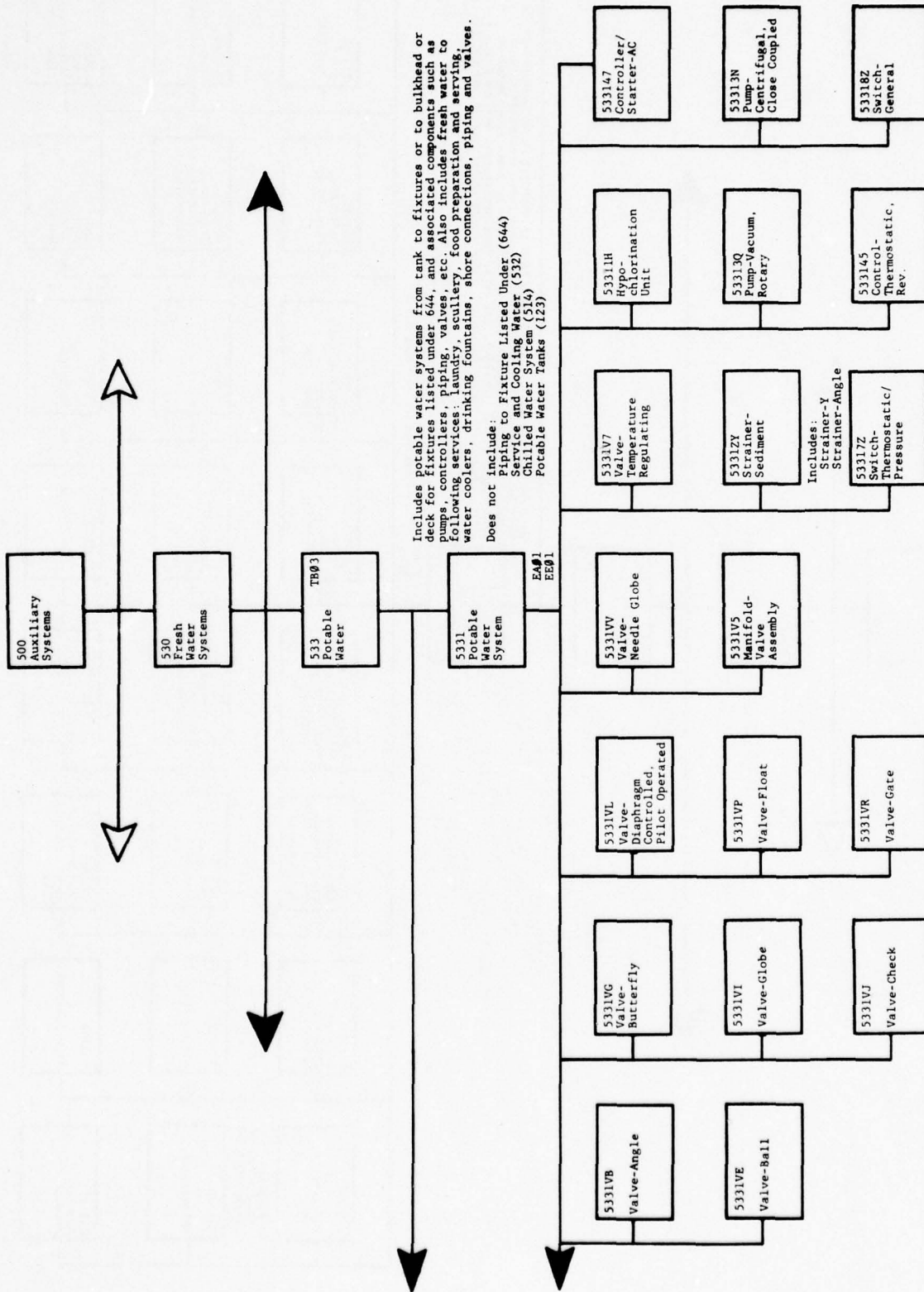

Includes potable water systems from tank to fixtures or to bulkhead or deck for fixtures listed under 644, and associated components such as pumps, controllers, piping, valves, etc. Also includes fresh water to following services: laundry, scullery, food preparation and serving, water coolers, drinking fountains, shore connections, piping and valves.

Does not include:  
 Piping to Fixture Listed Under (644)  
 Service and Cooling Water (532)  
 Chilled Water System (514)  
 Potable Water Tanks (123)



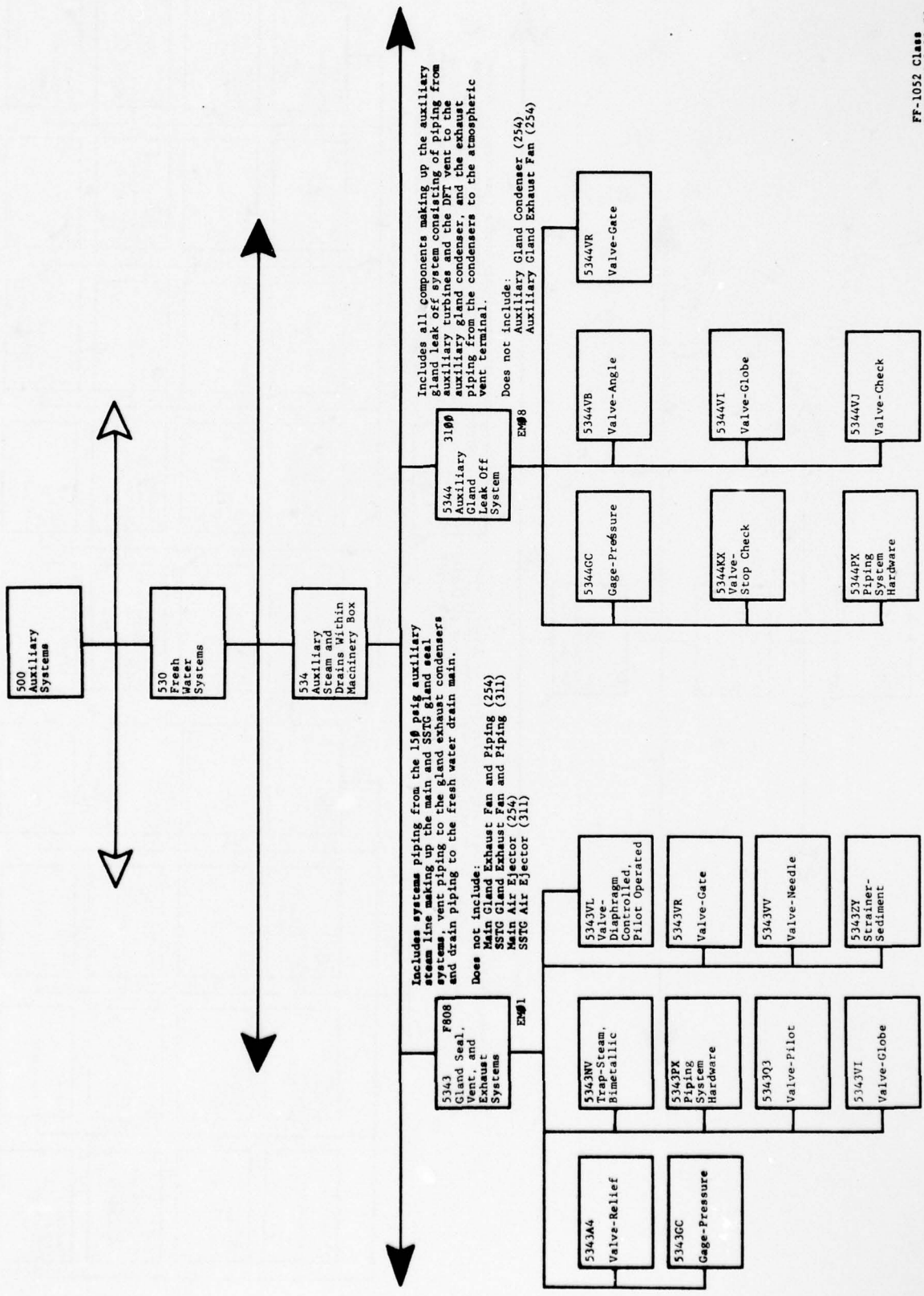

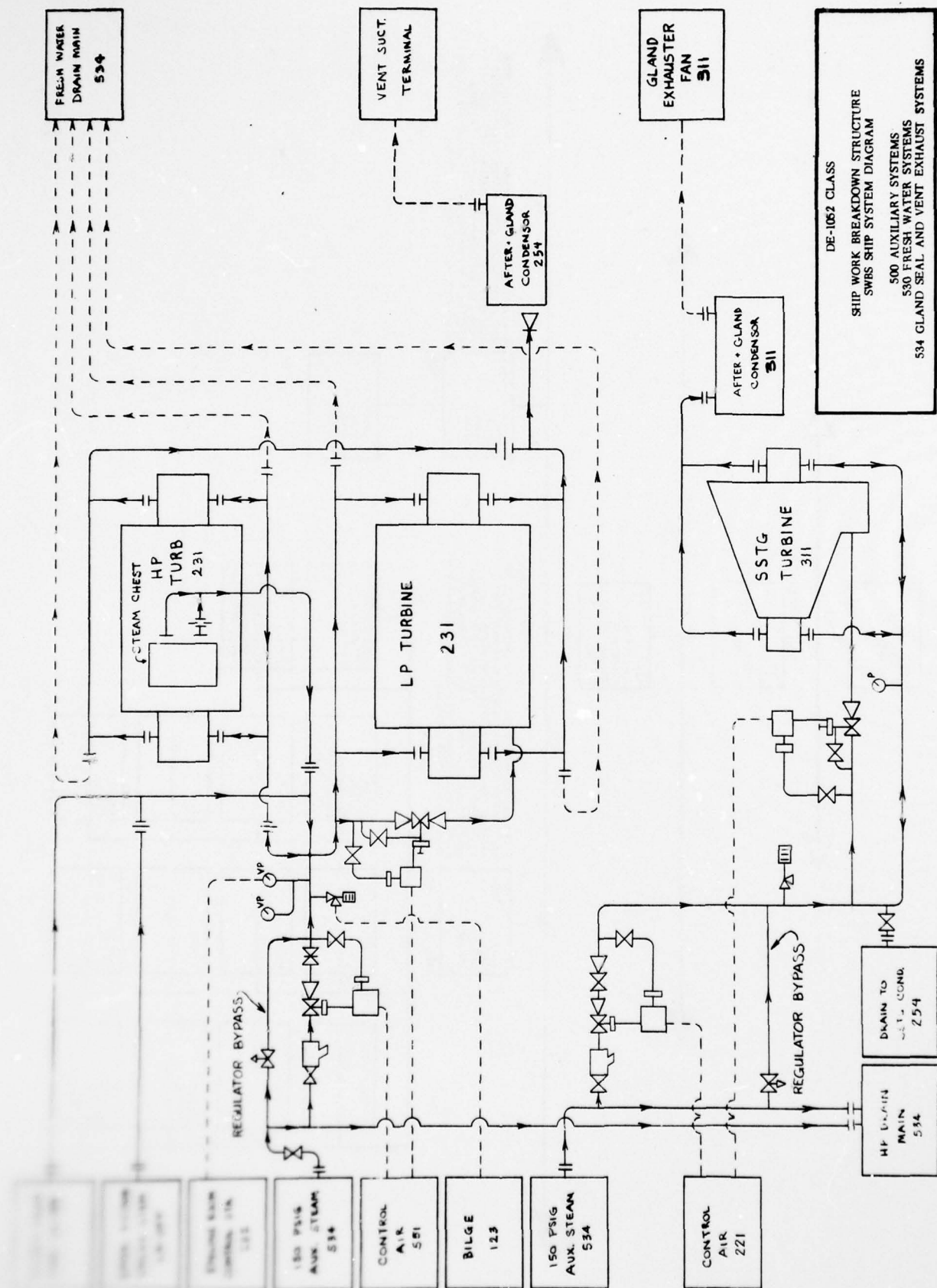

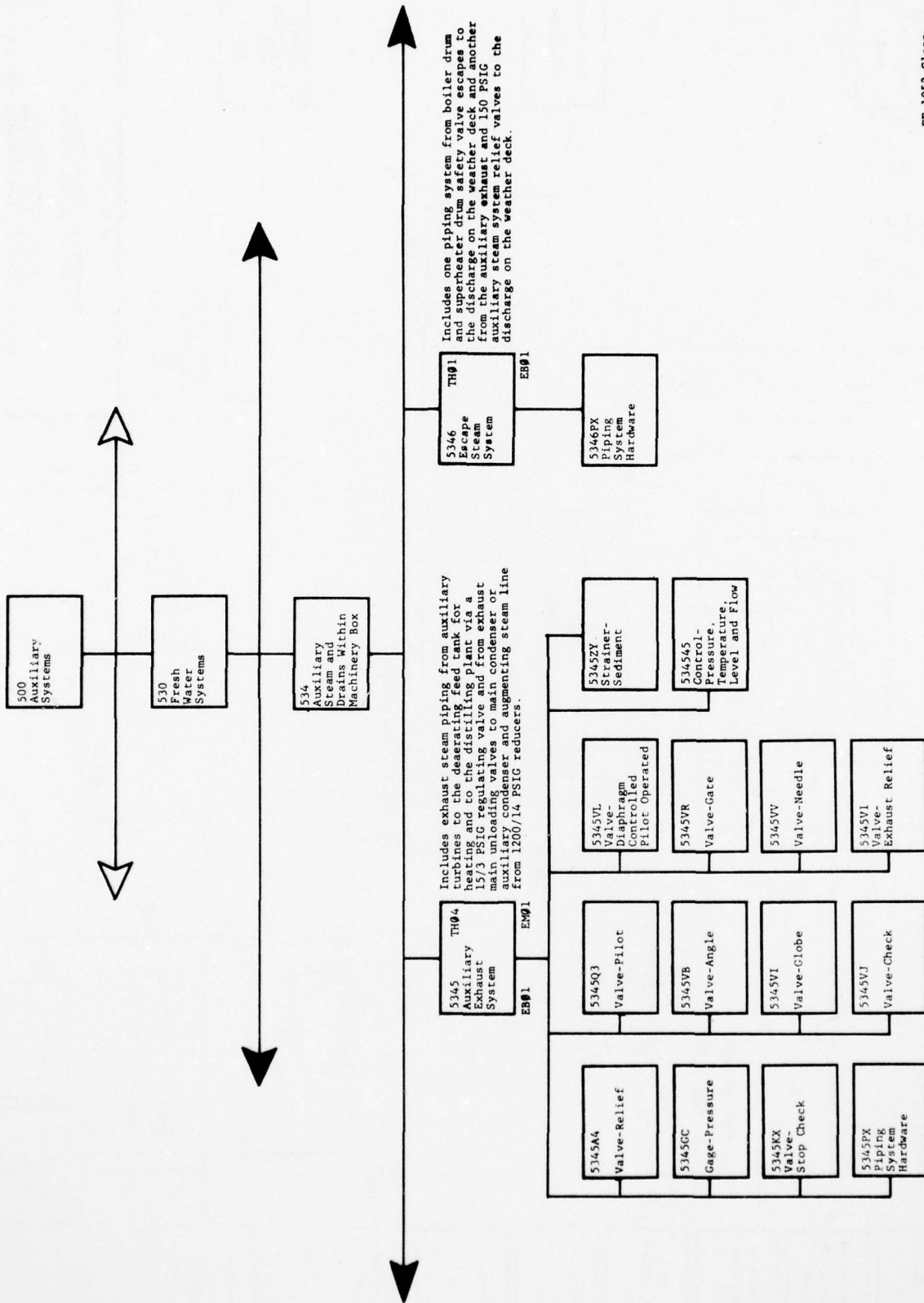



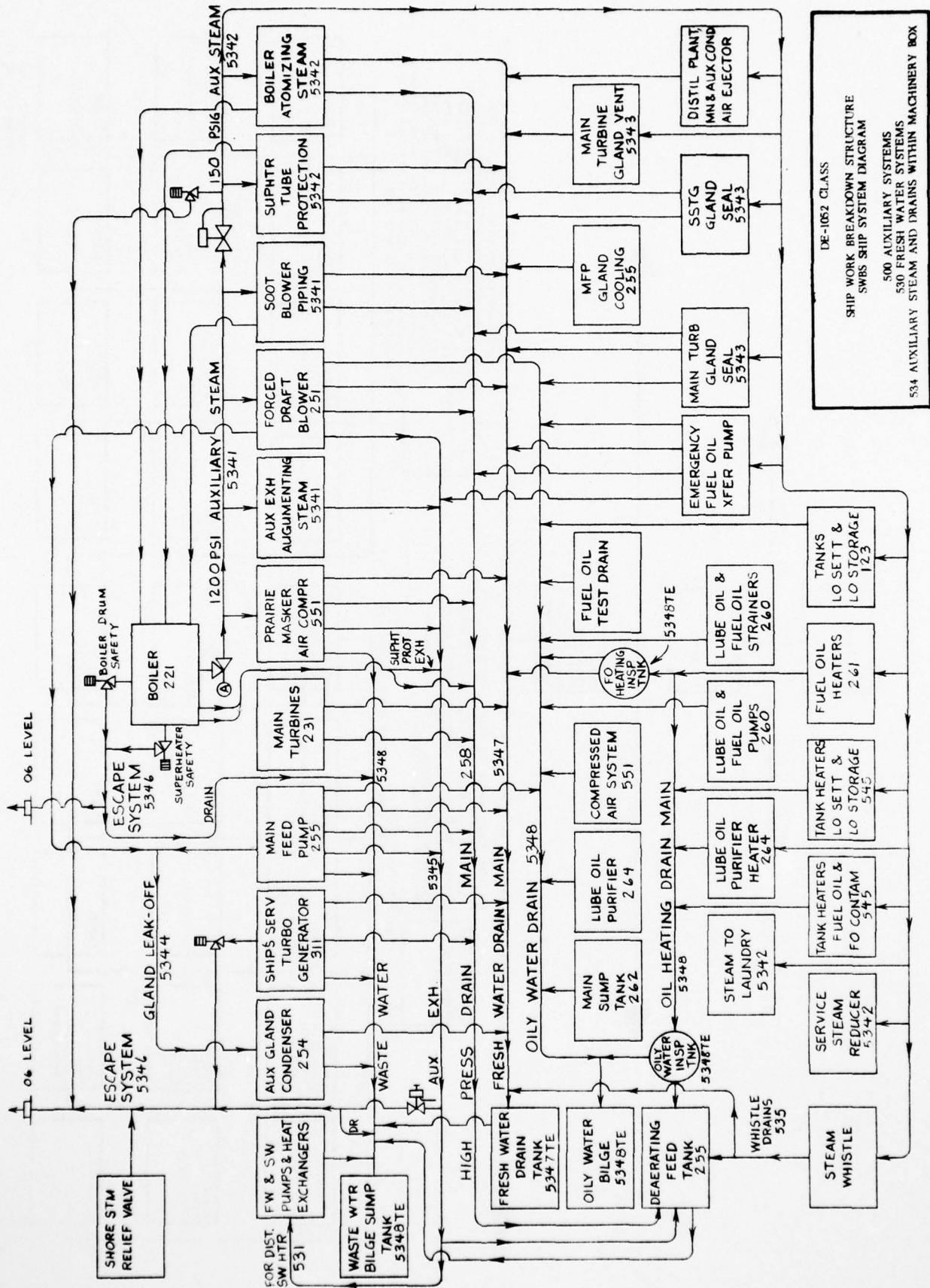

DE-1062 CLASS  
 SHIP WORK BREAKDOWN STRUCTURE  
 SWBS SHIP SYSTEM DIAGRAM  
 500 AUXILIARY SYSTEMS  
 530 FRESH WATER SYSTEMS  
 534 AUXILIARY STEAM AND DRAINS WITHIN MACHINERY BOX

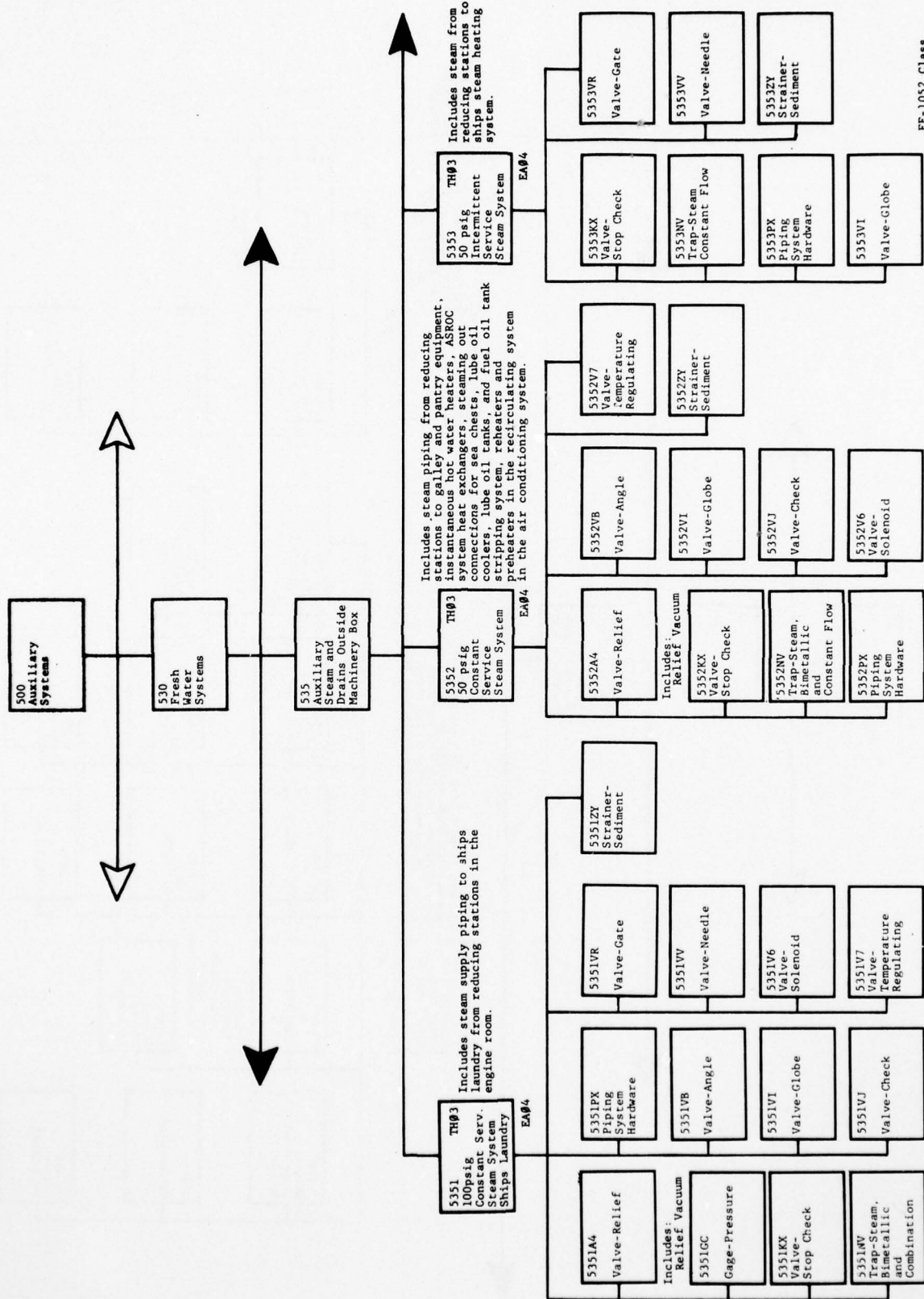

FF-1052 Class  
Prepared 9-18-76



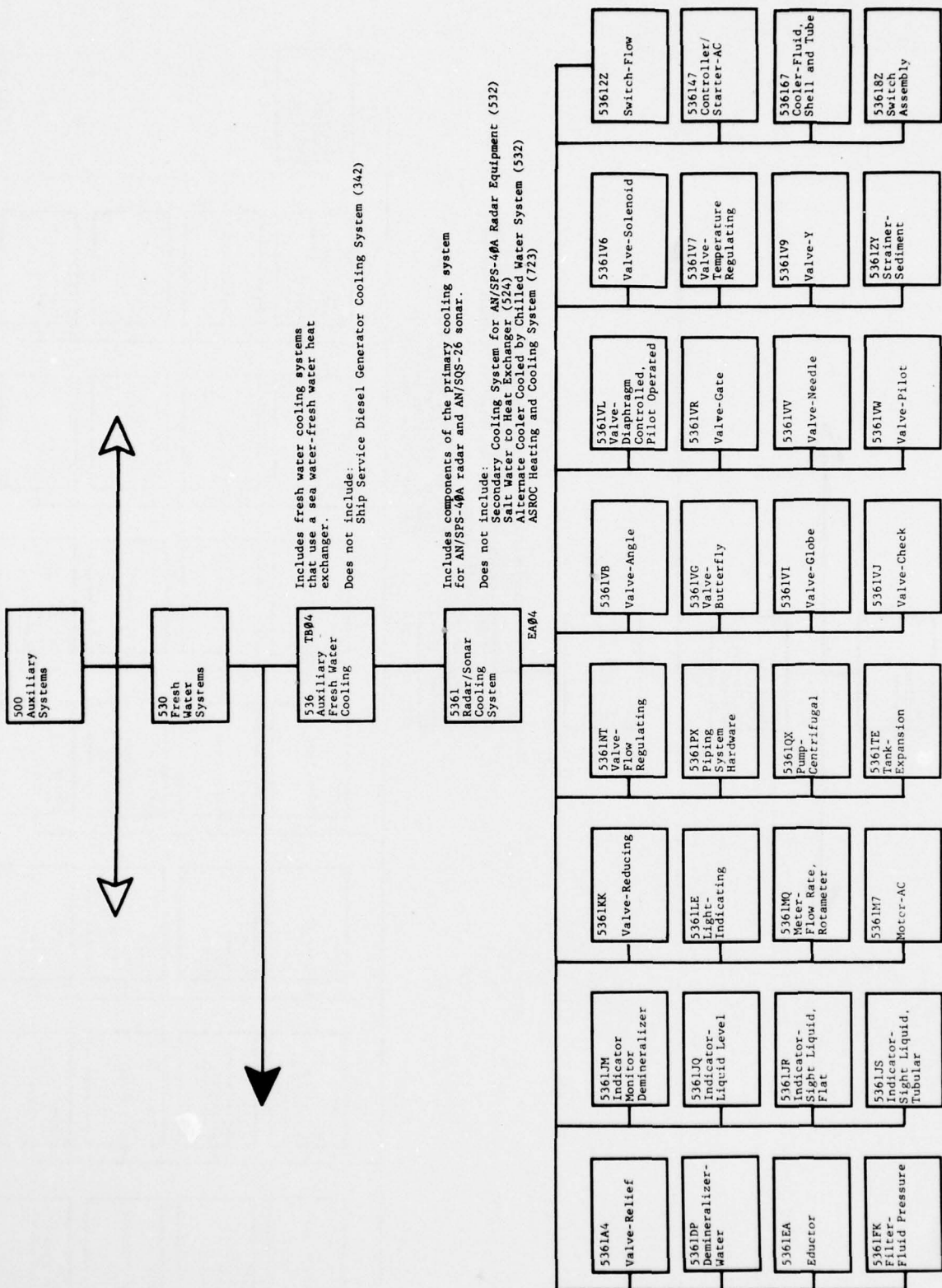

FF-1052 Class  
Prepared 9-18-76

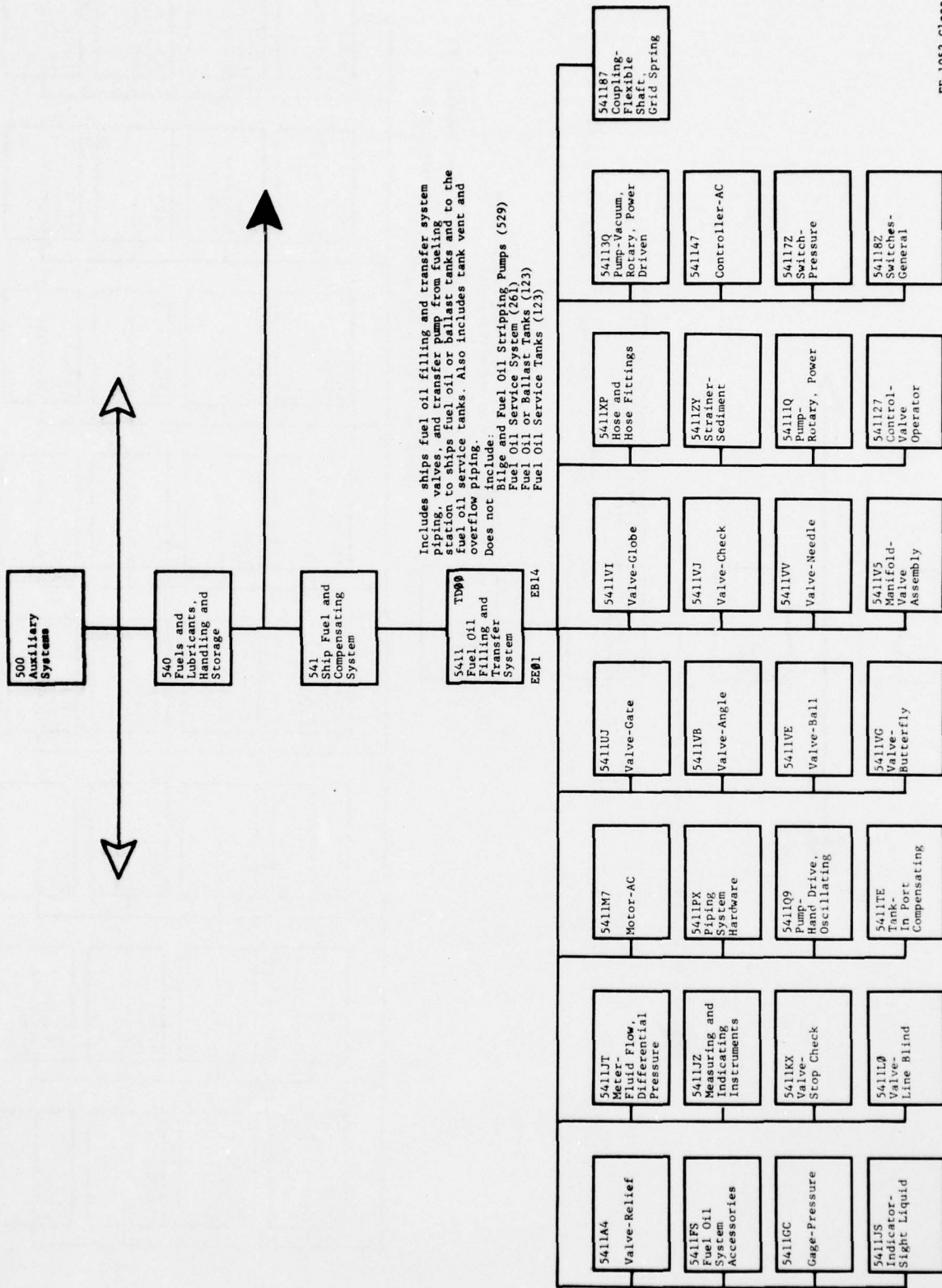

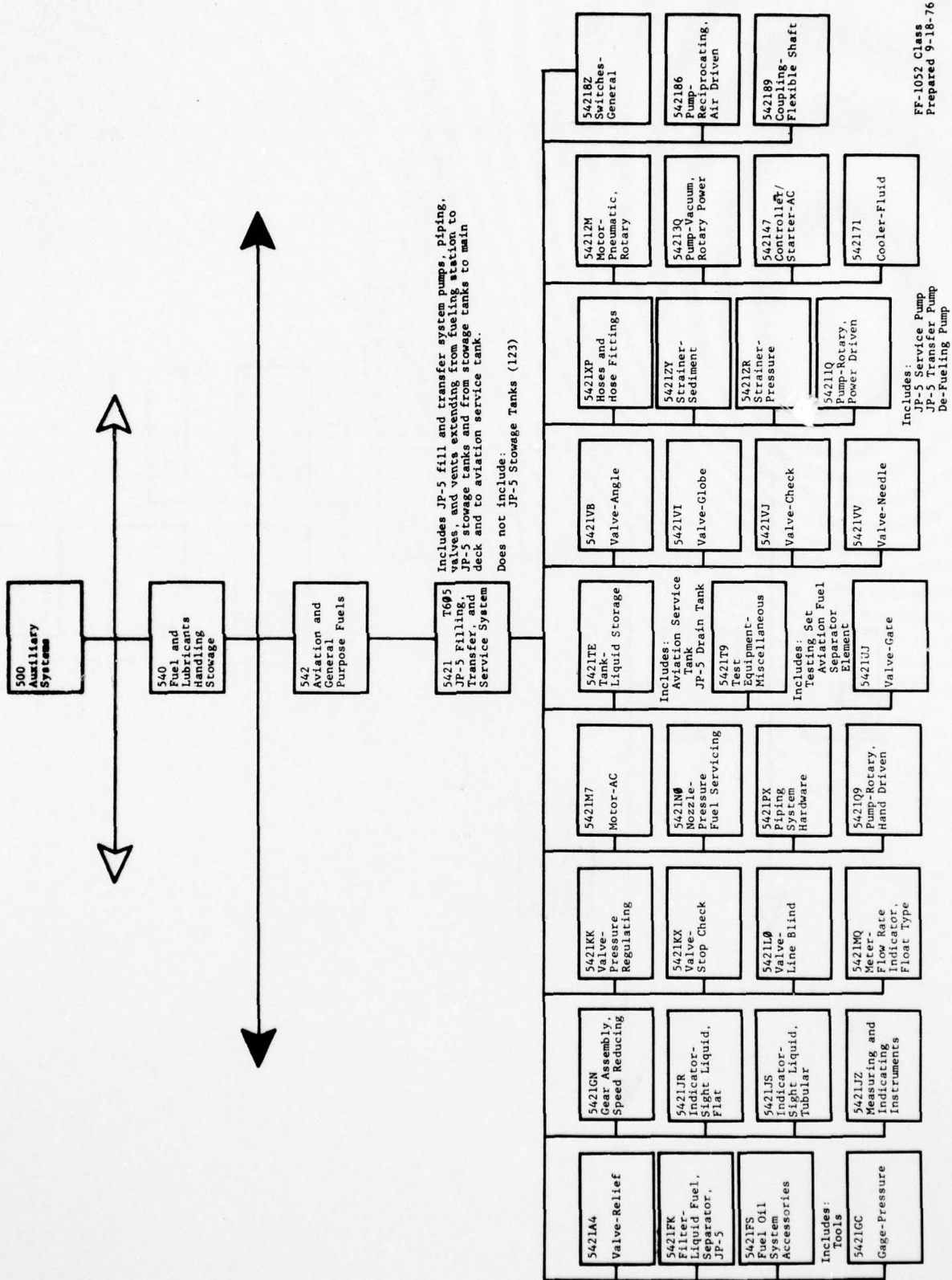

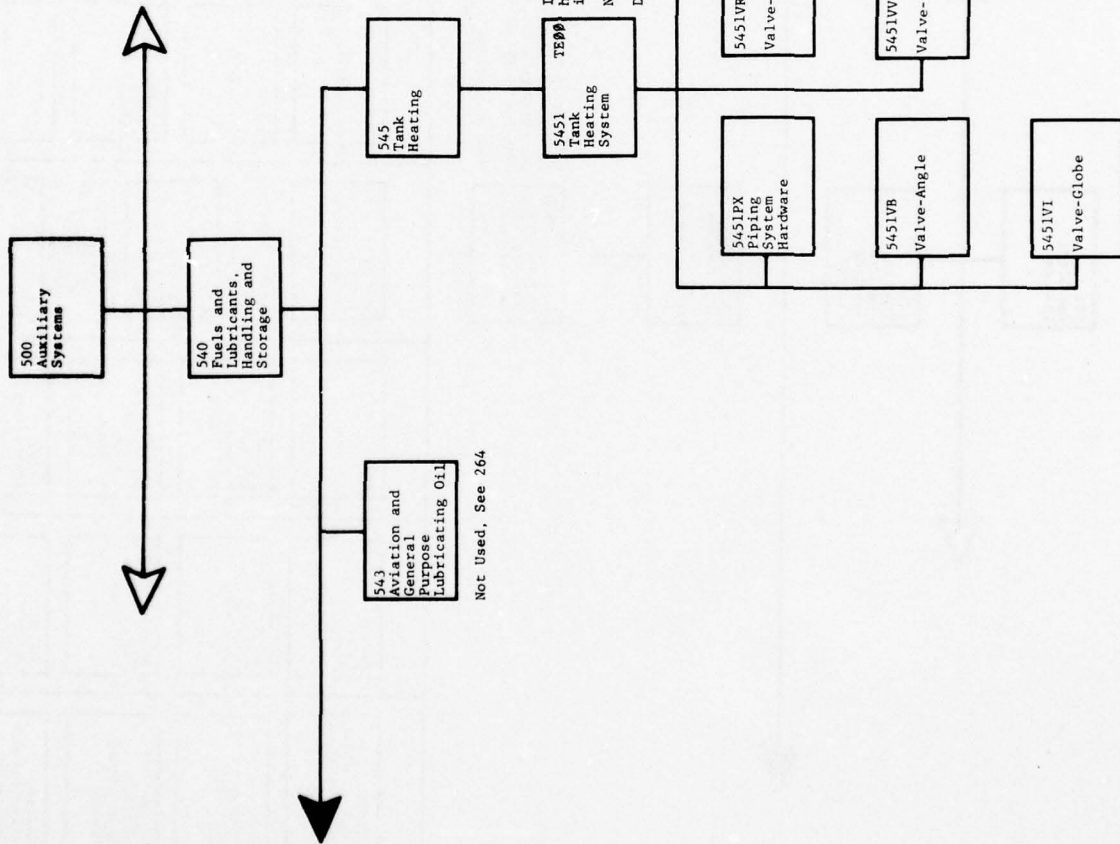

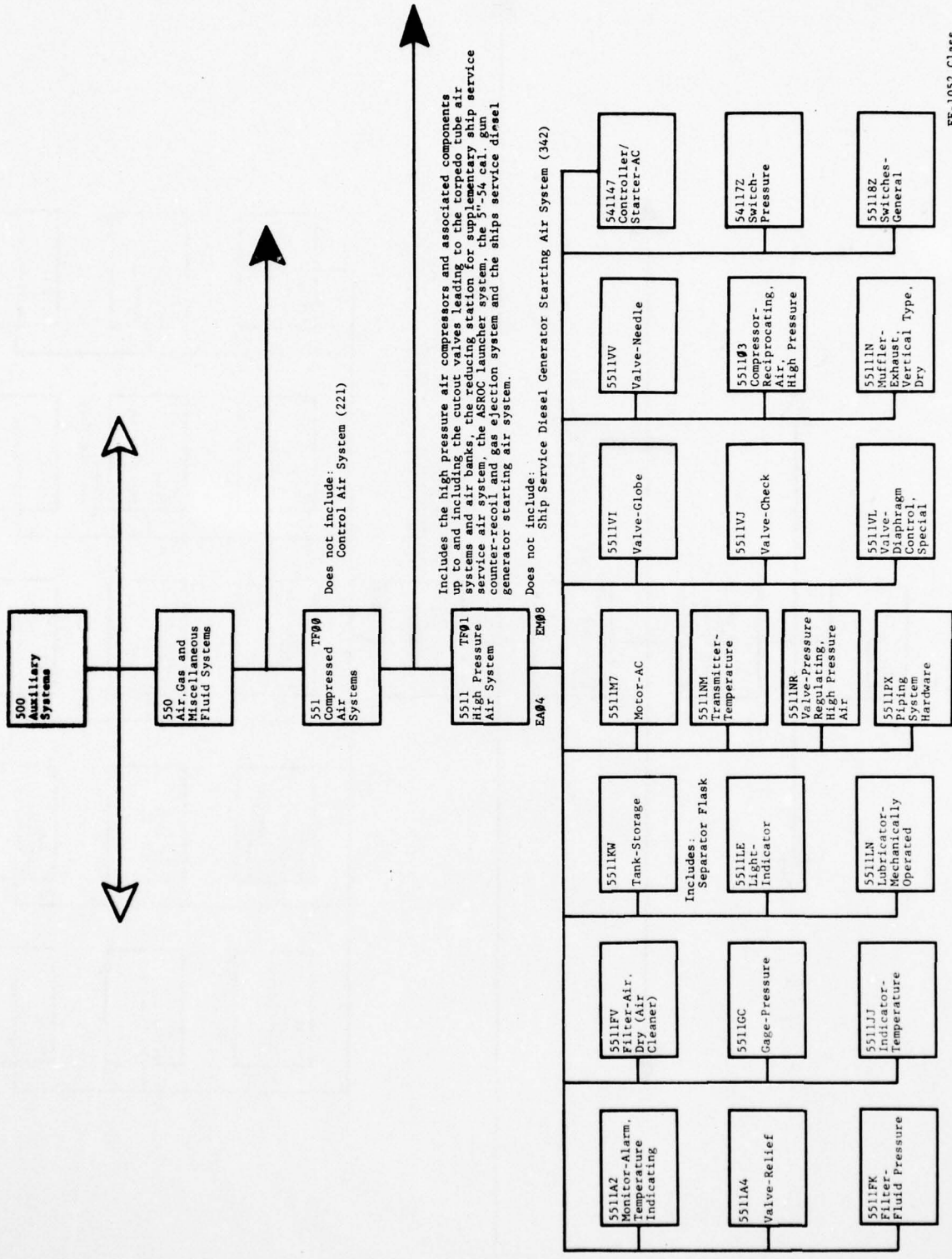

Does not include:  
Control Air System (221)

Includes the high pressure air compressors, and associated components  
and including, the various valves leading to the torpedo tube air  
system and air line to the ASROC launcher system, the ship service  
counter-recoil and gas ejection system and the ships service diesel  
generator starting air system.

Does not include:  
Ship Service Diesel Generator Starting Air System (342)

FF-1052 Class  
Prepared 9-18-76

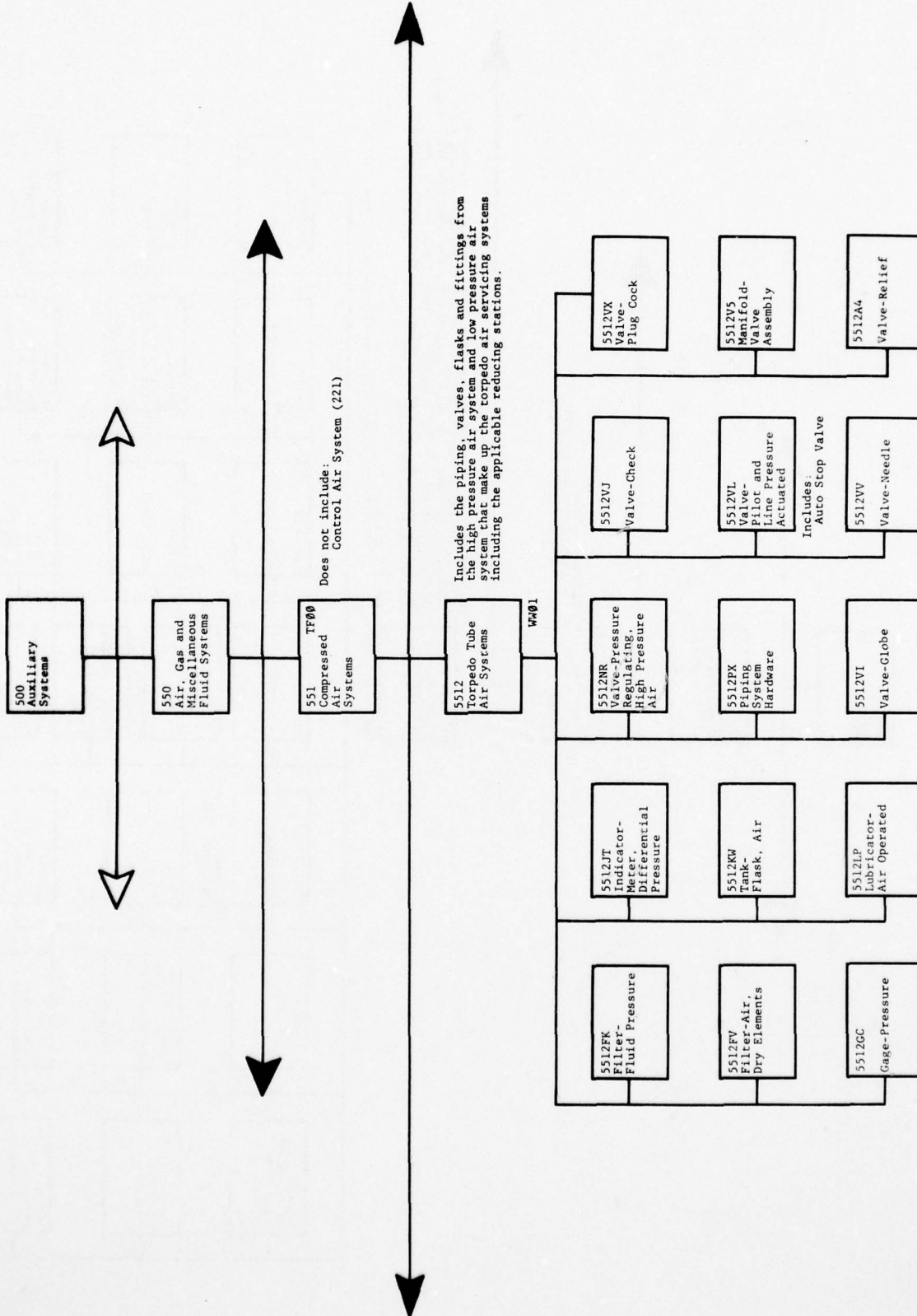

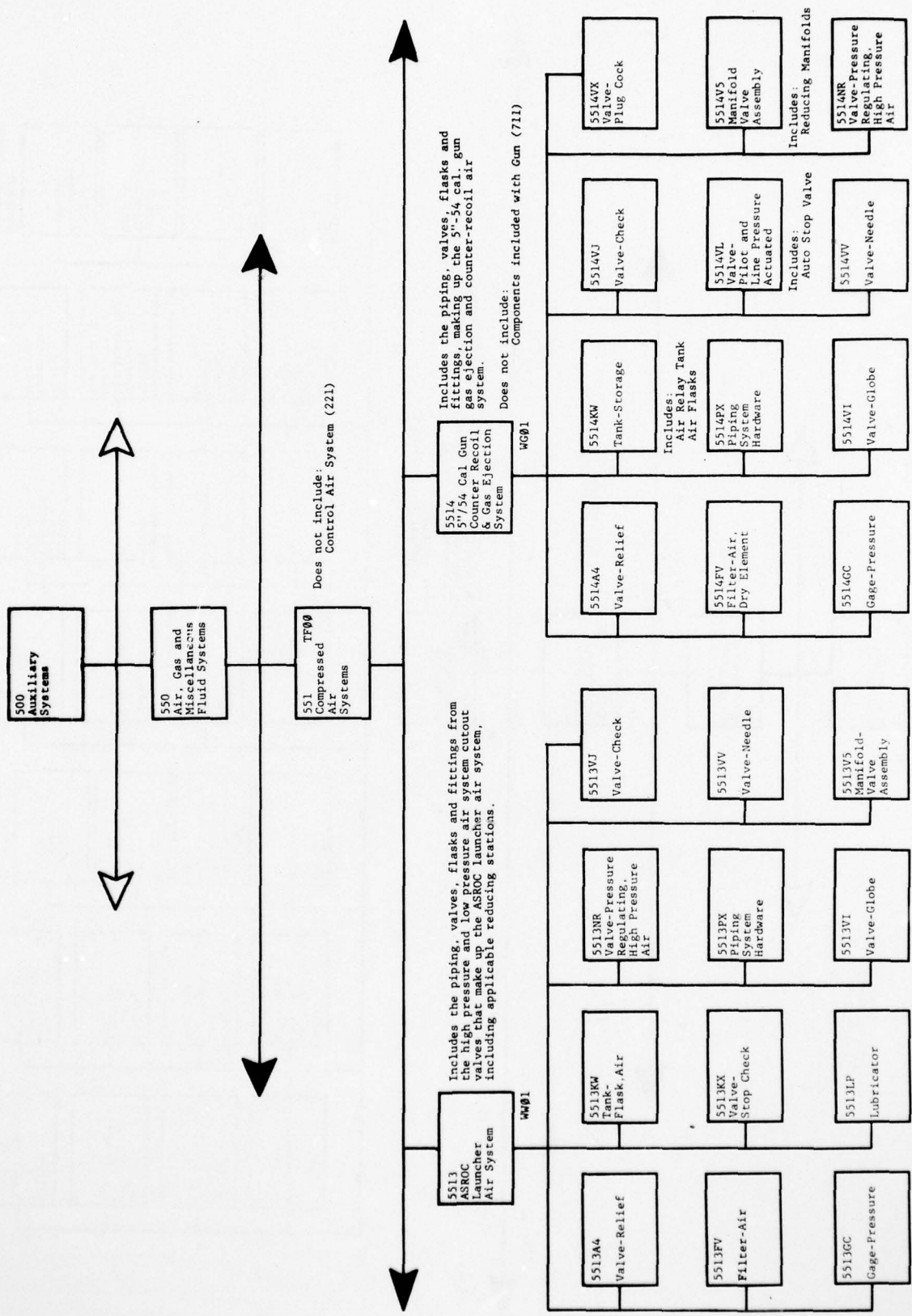

FF-1052 Class  
Prepared 9-18-76

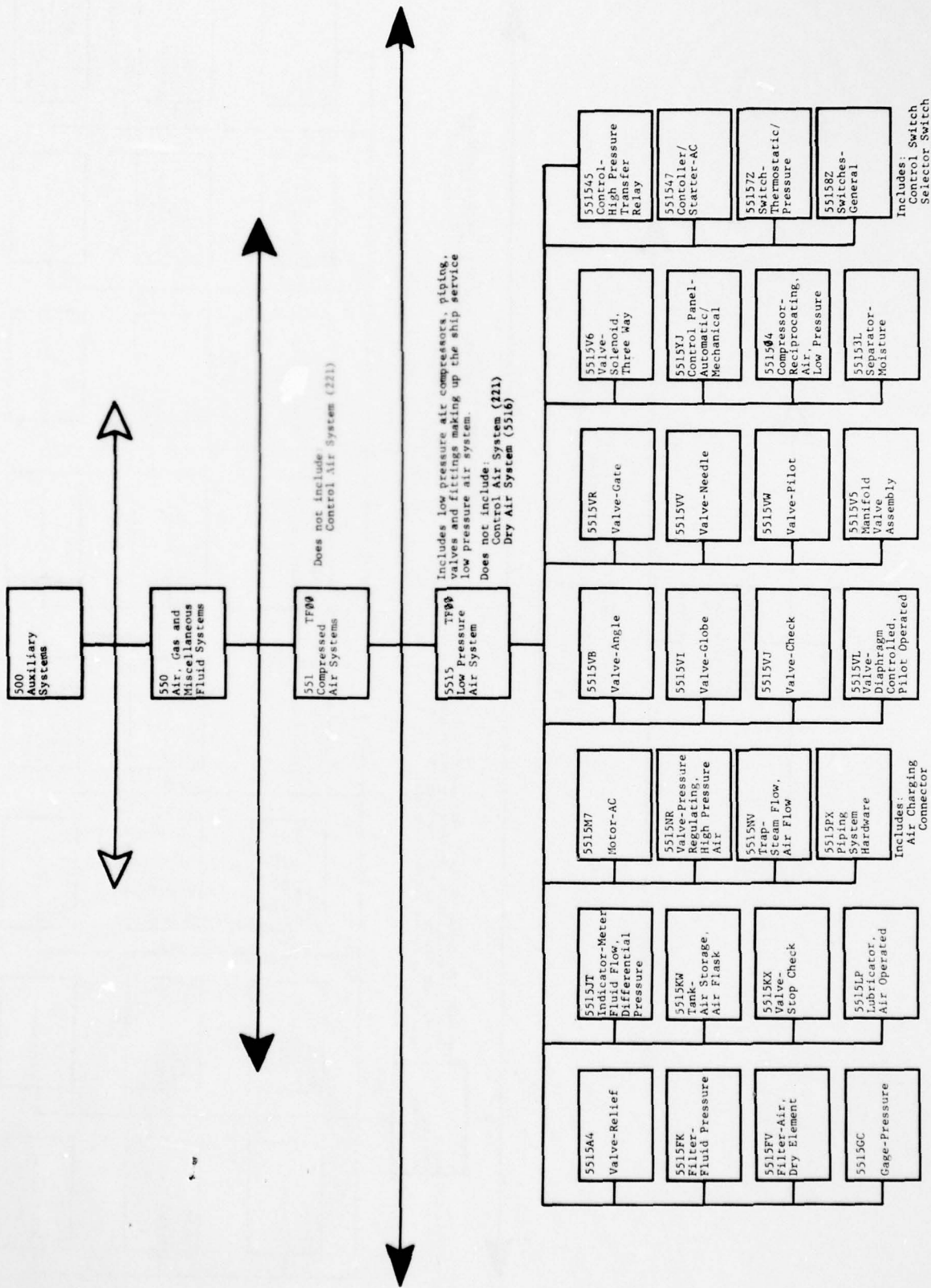

FF-1052 Class  
Prepared 9-18-76

AD-A052 469

ARINC RESEARCH CORP ANNAPOLIS MD  
SHIP SYSTEMS DEFINITION AND INDEX (SWBS STAGING DIAGRAMS) FOR F--ETC(U)  
OCT 76

N00140-76-D-0813

F/G 13/10

NL

UNCLASSIFIED

1804-01-1-1547

3 OF 3  
ADA  
062469

FILE

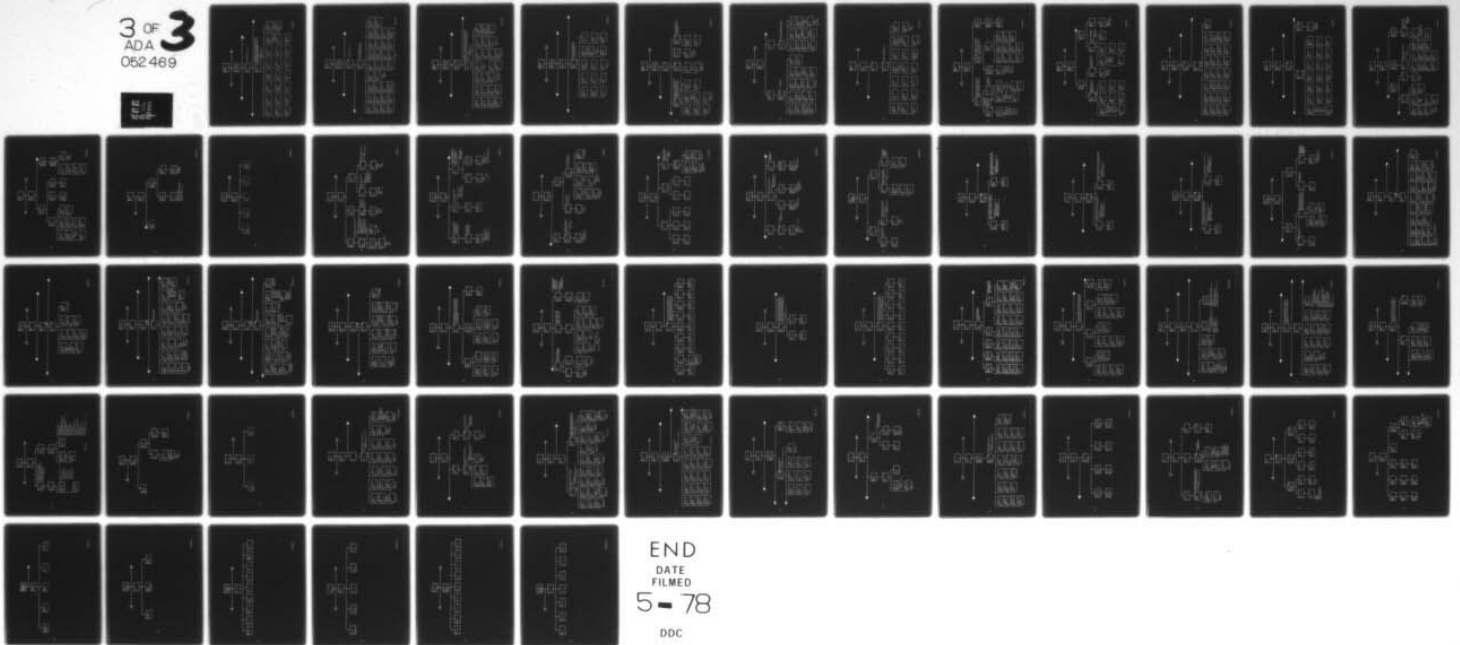

END  
DATE  
FILMED  
5-78  
DDC



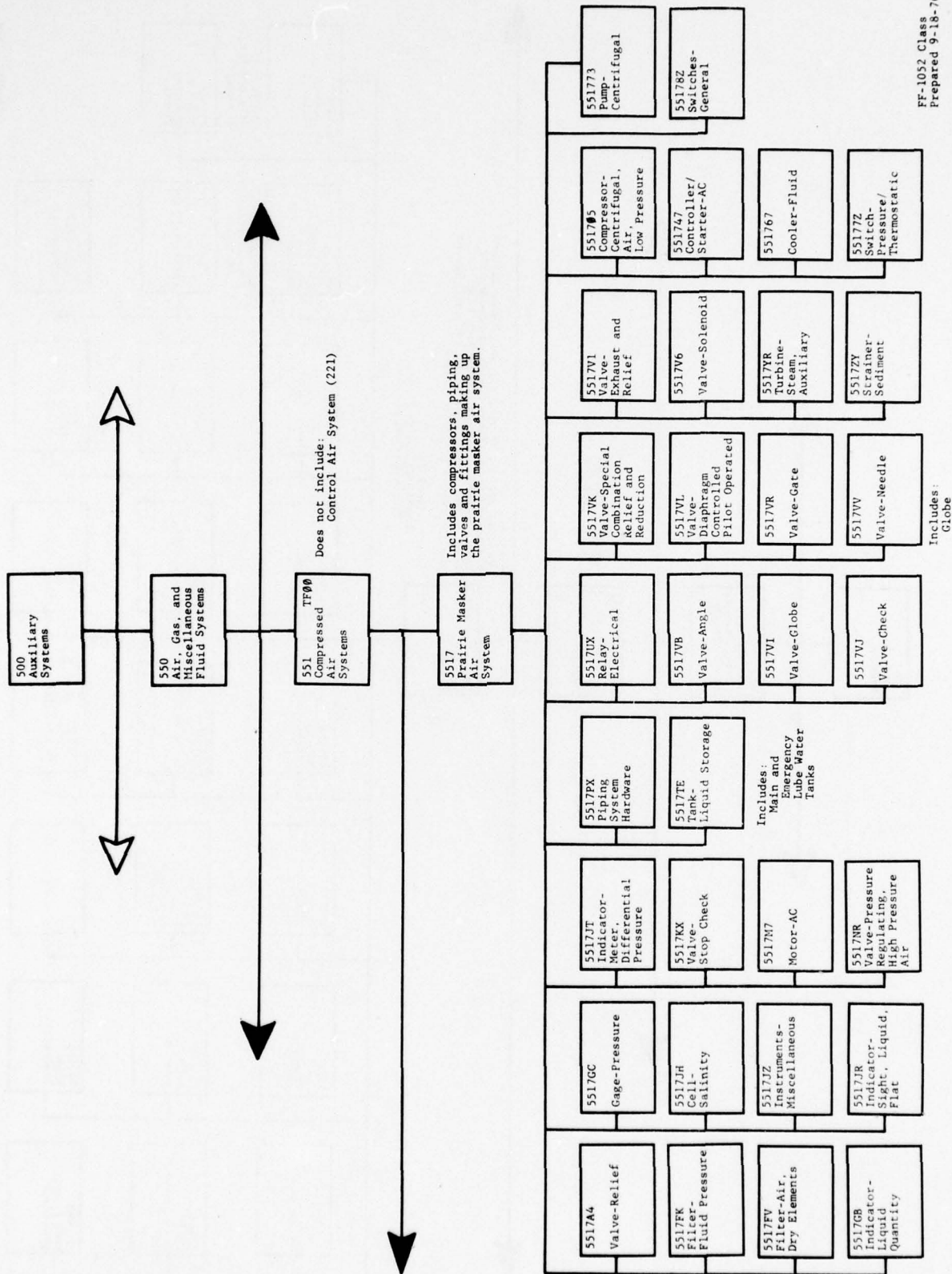

FF-1032 Class  
Prepared 9-18-76

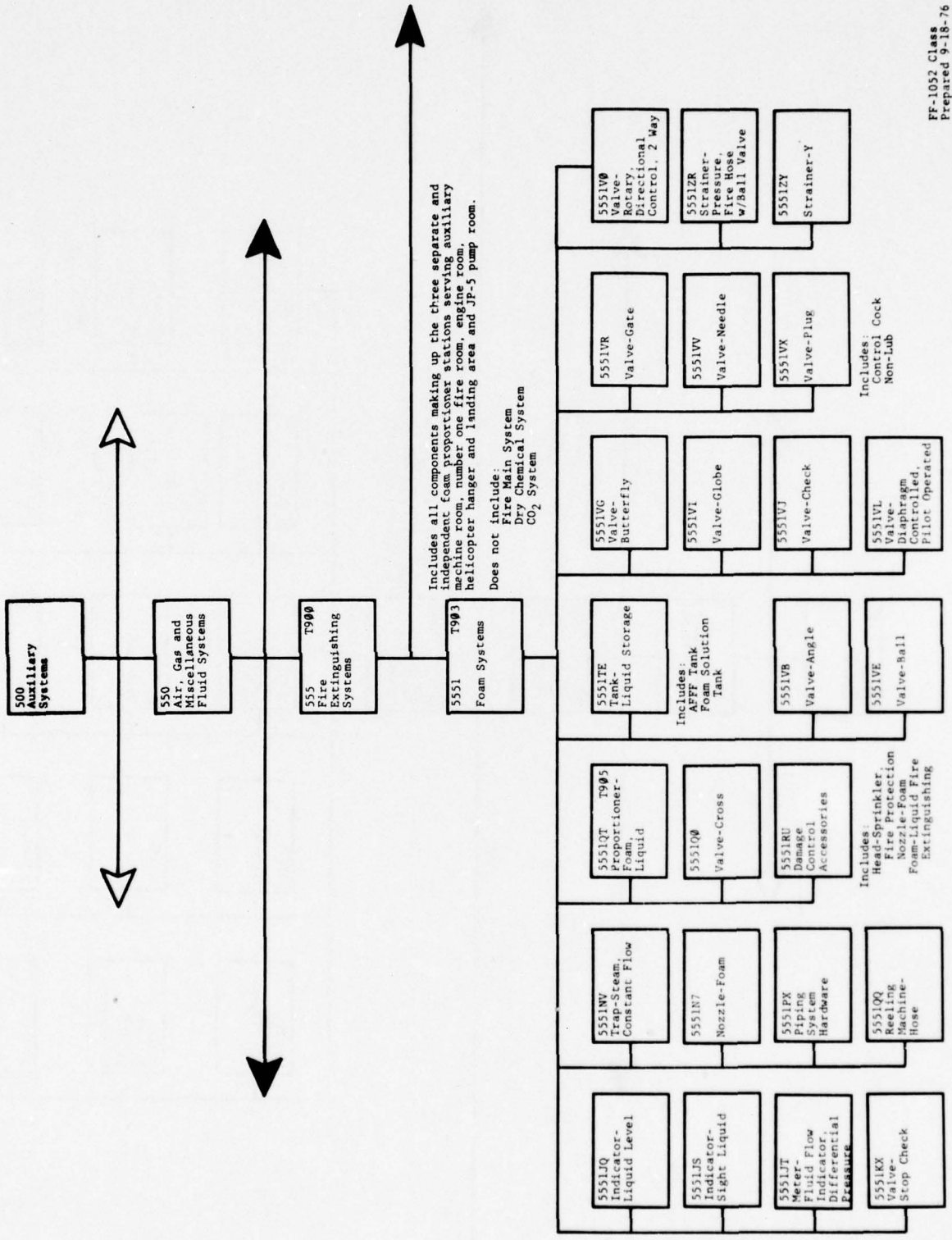

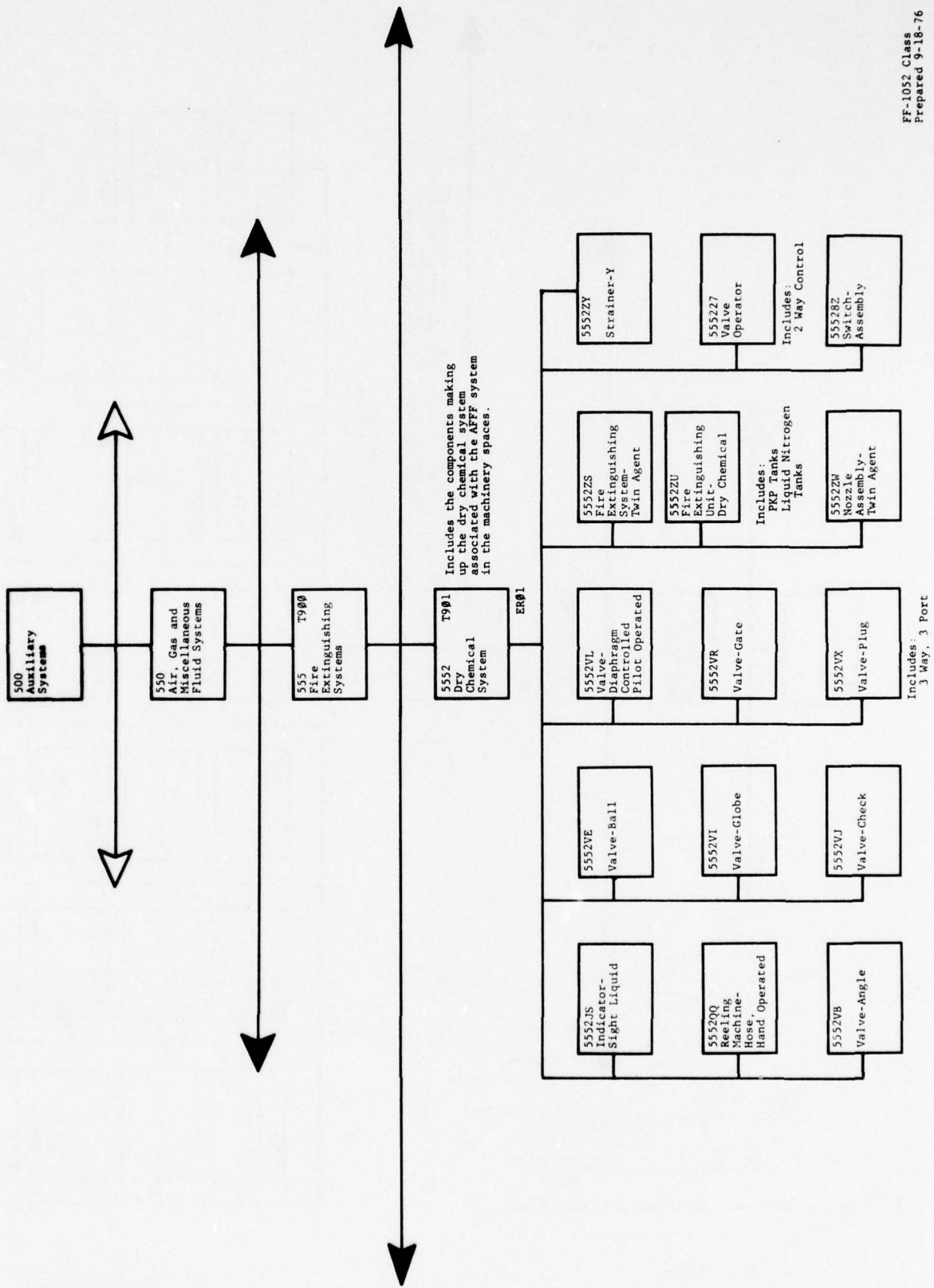





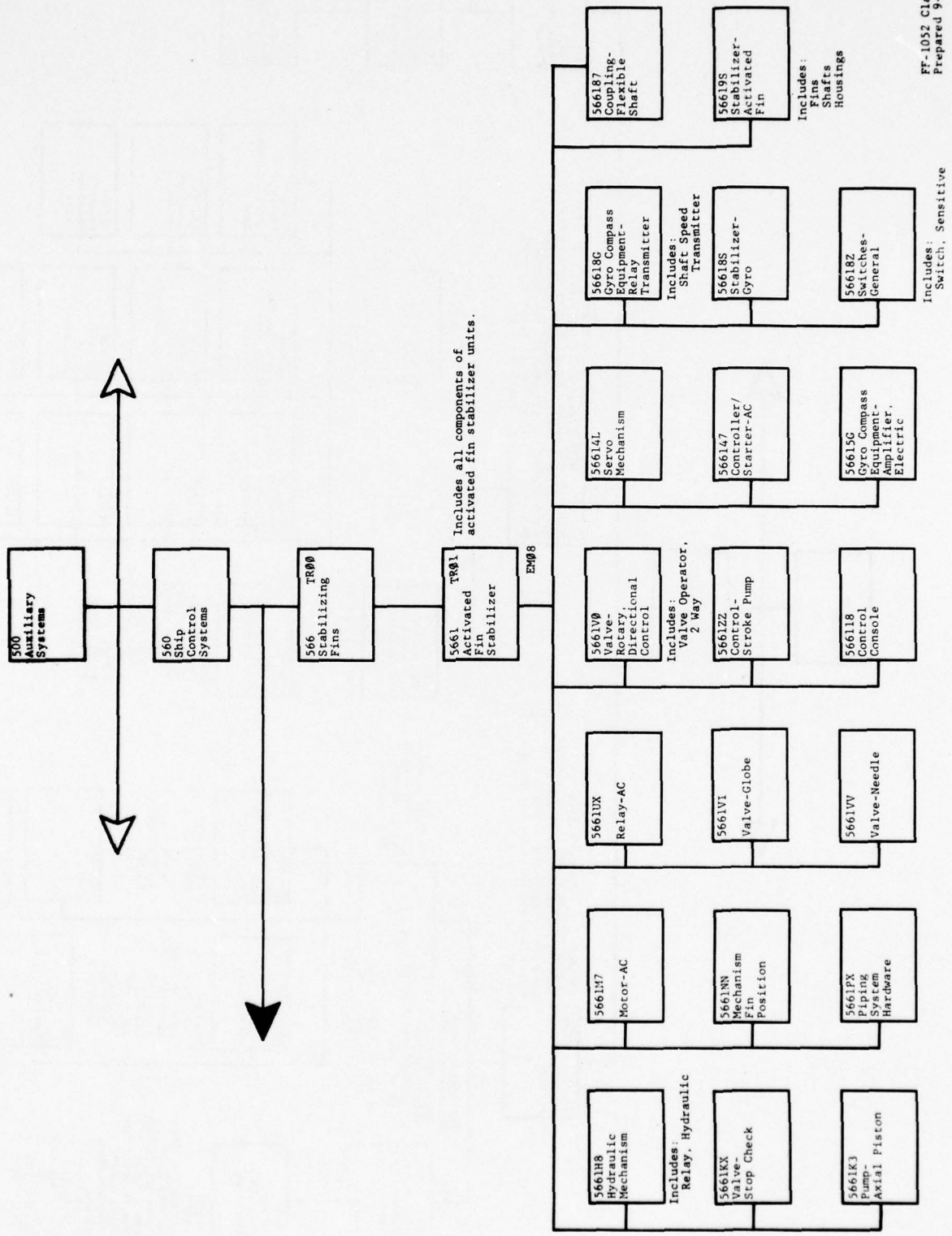

FF-1052 Class  
Prepared 9-18-76

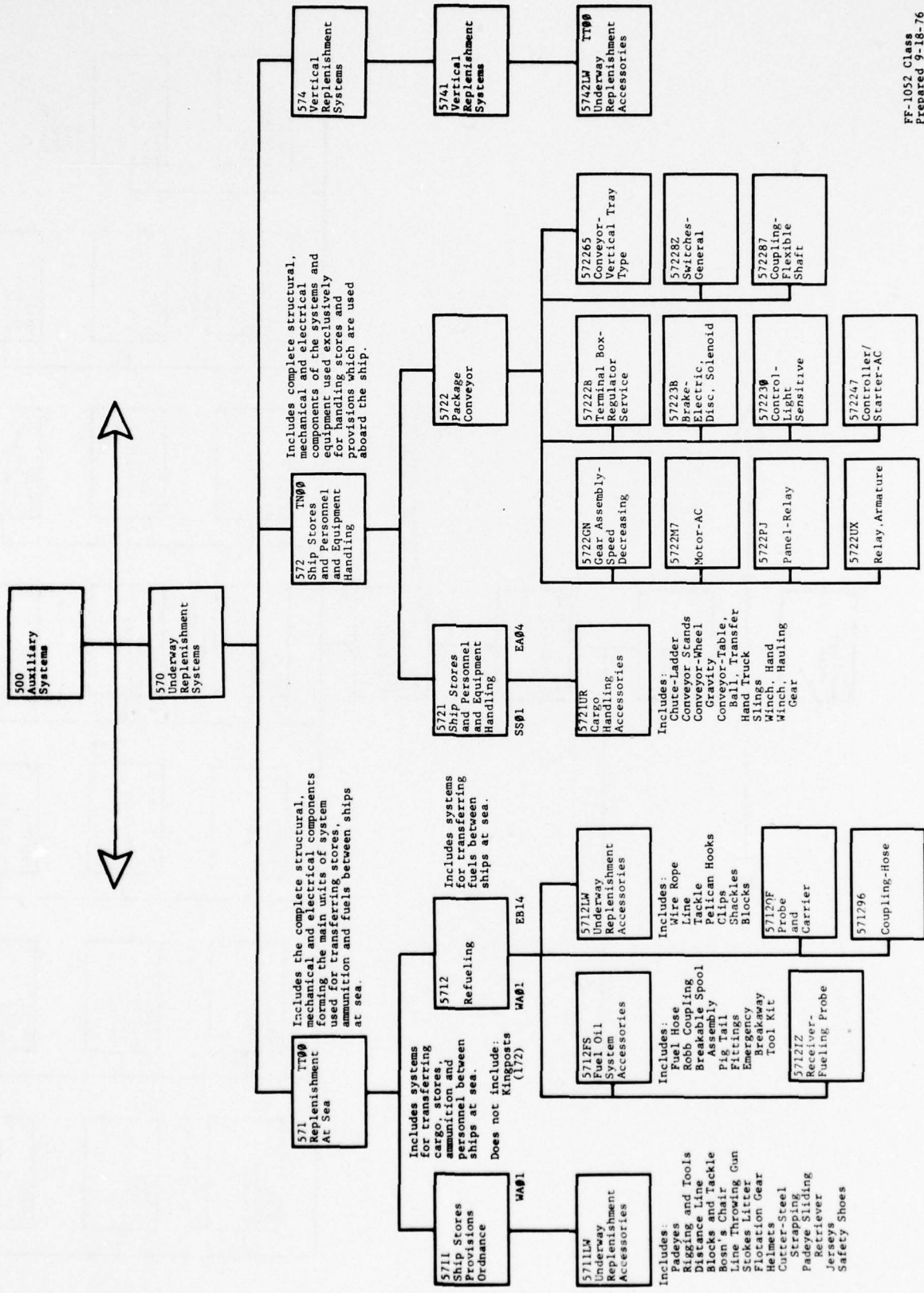

FF-1052 Class  
Prepared 9-18-76



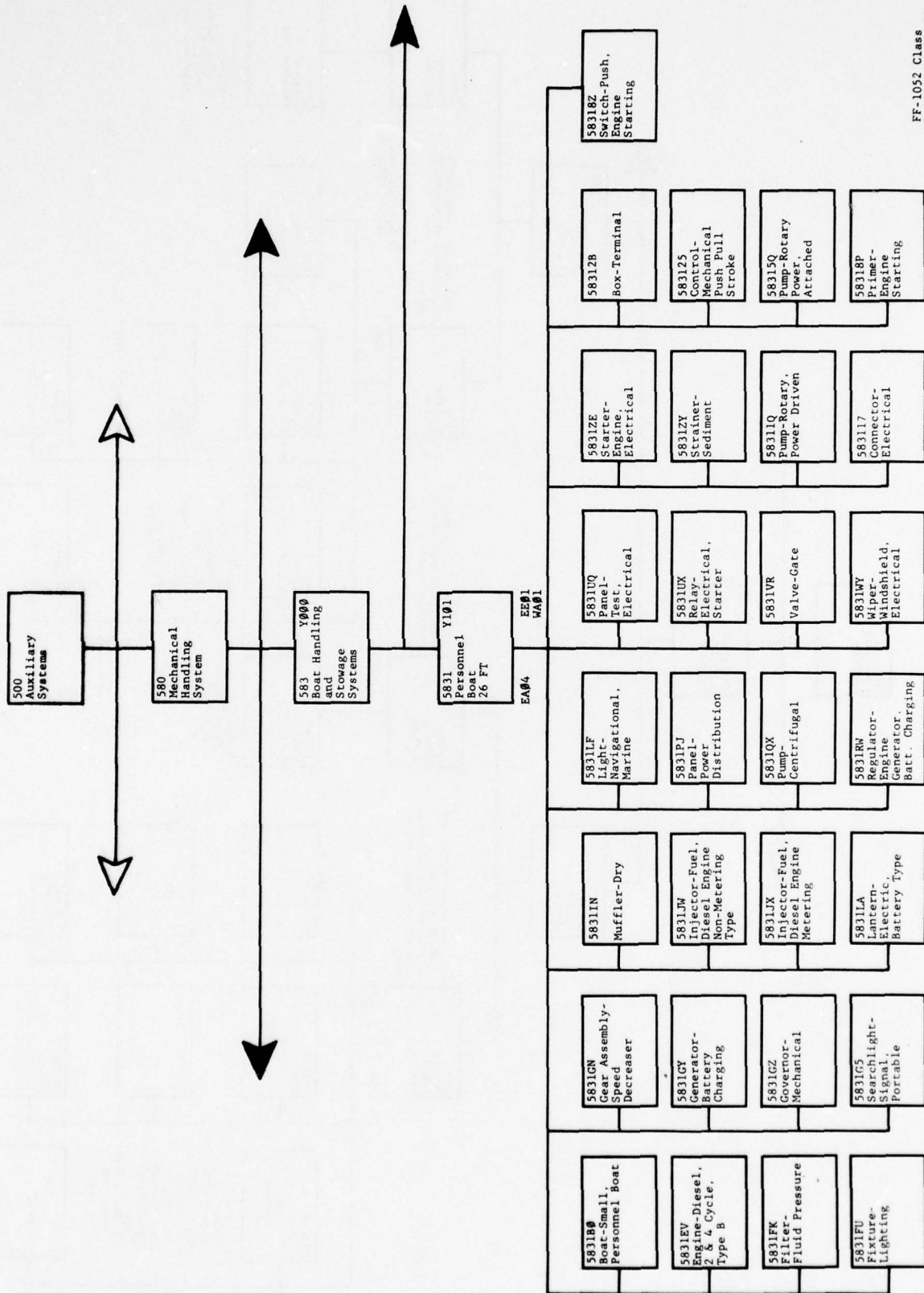

FF-1052 Class  
Prepared 9-23-76

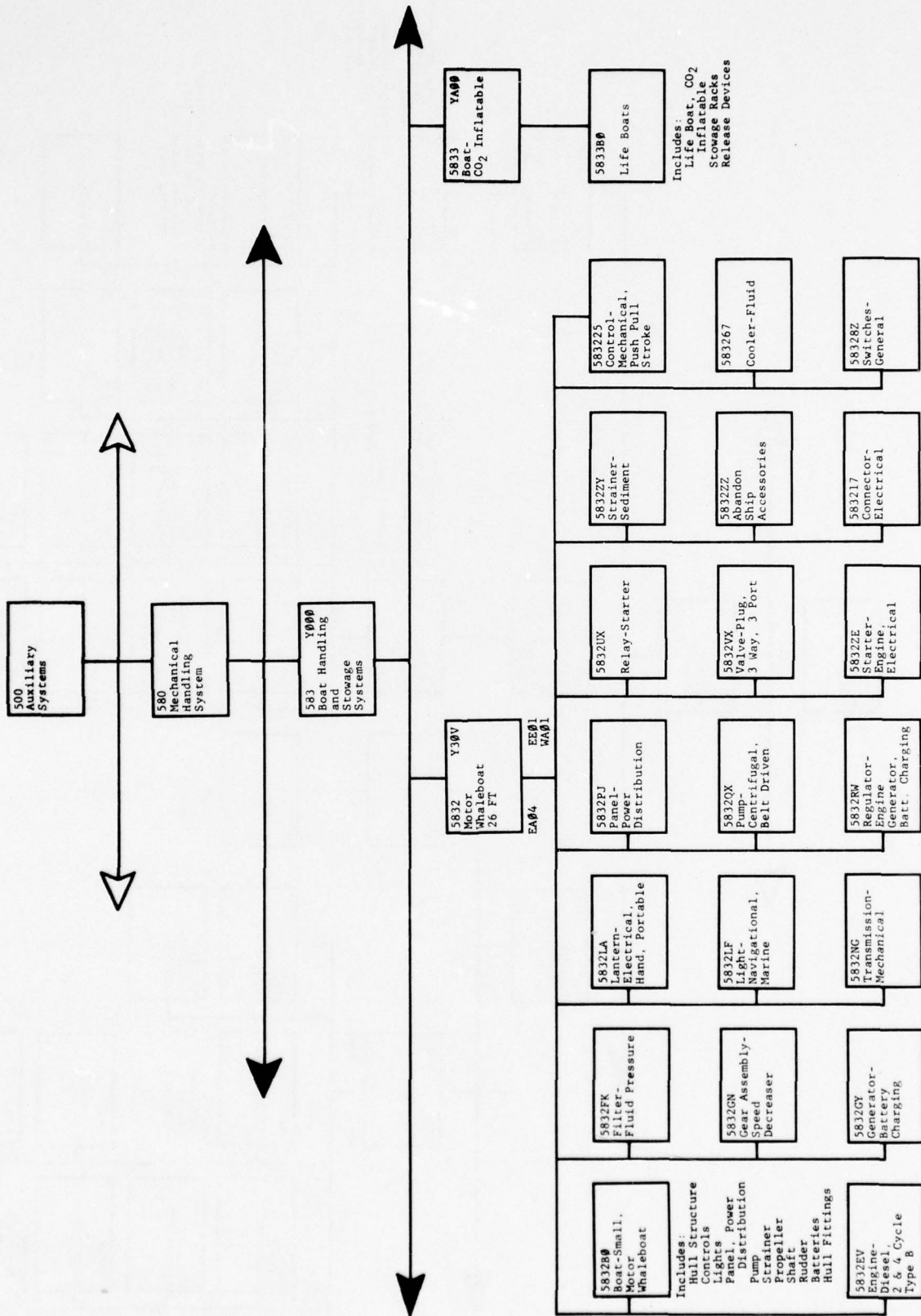

FF-1052 Class  
Prepared 9-23-76

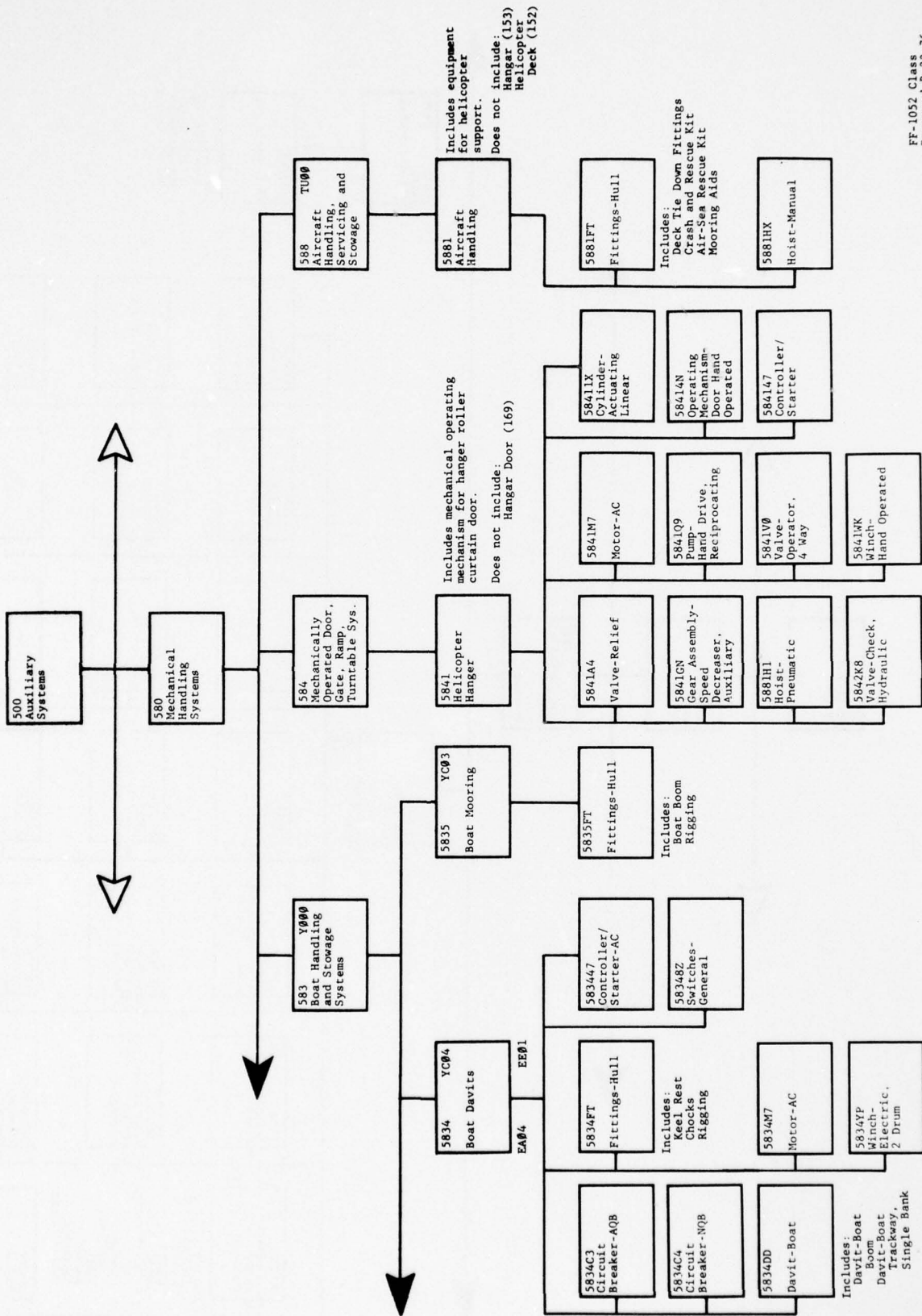

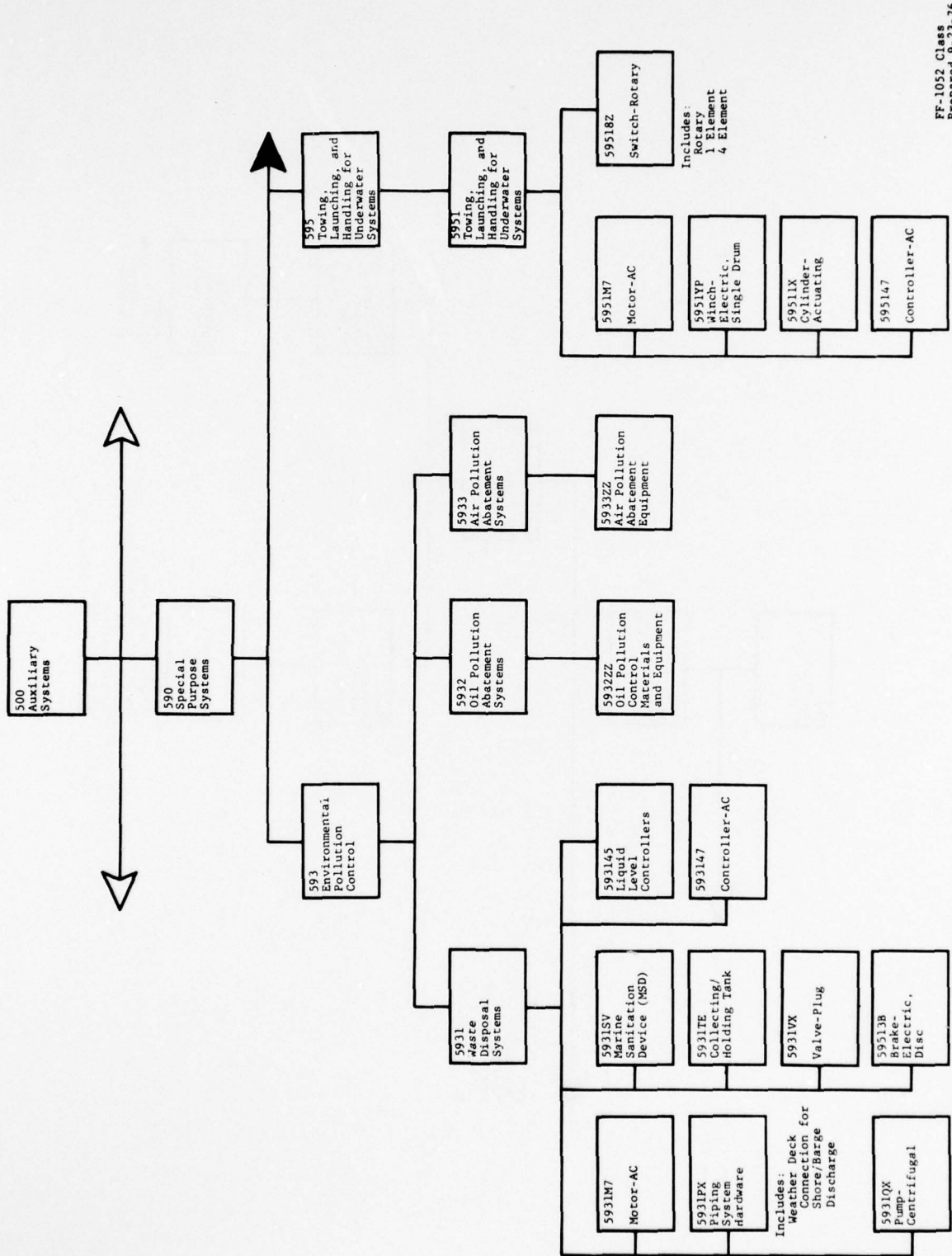

FF-1052 Class  
Prepared 9-23-76

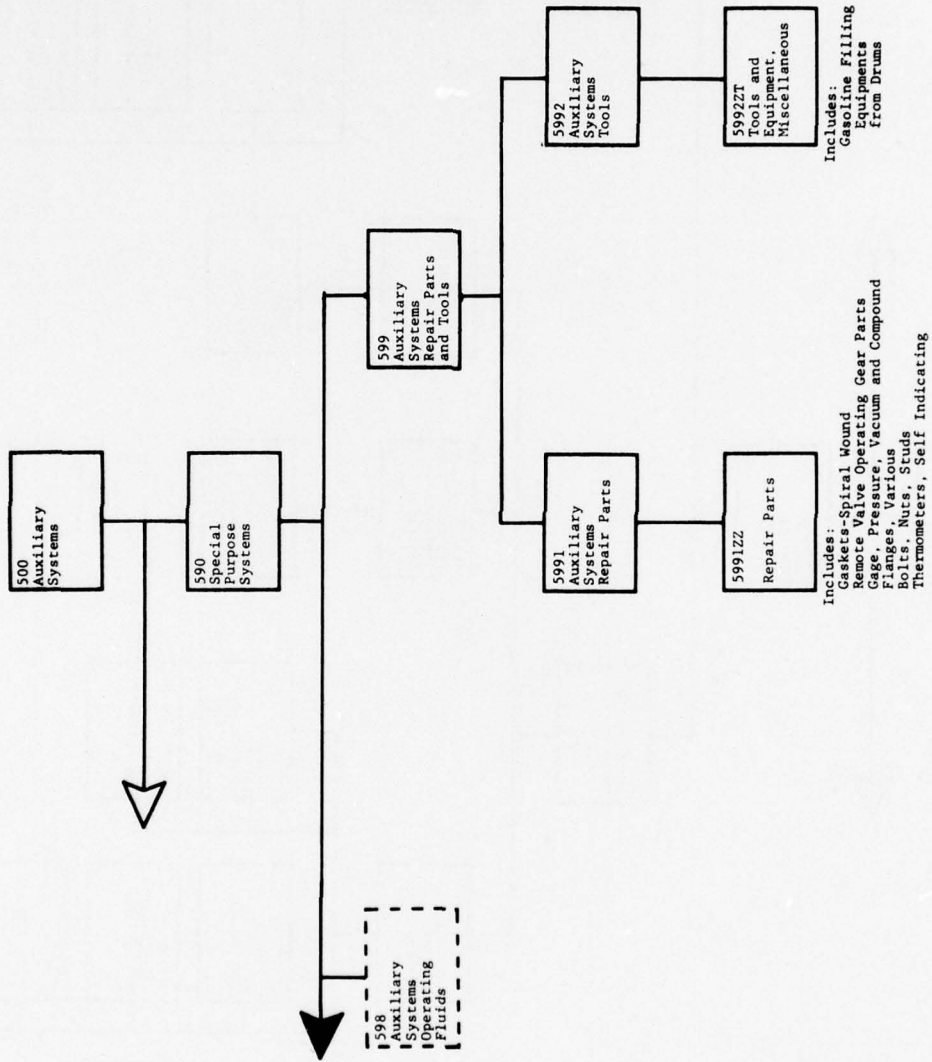

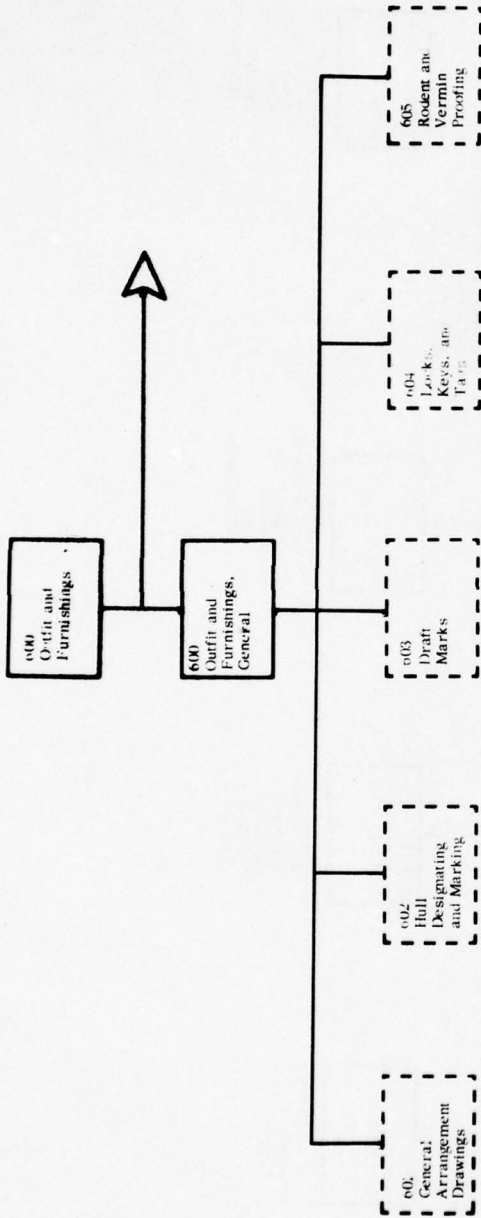

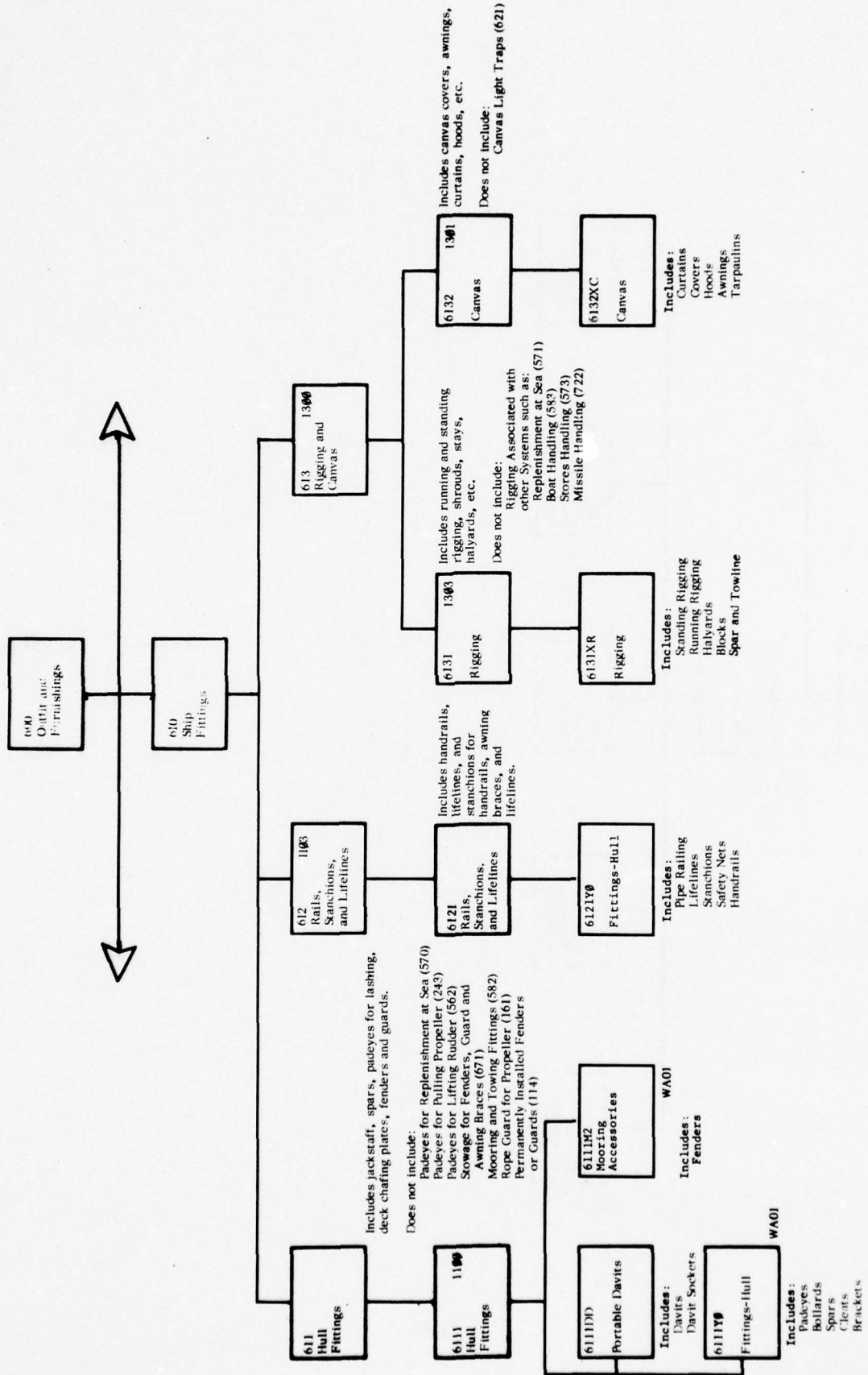

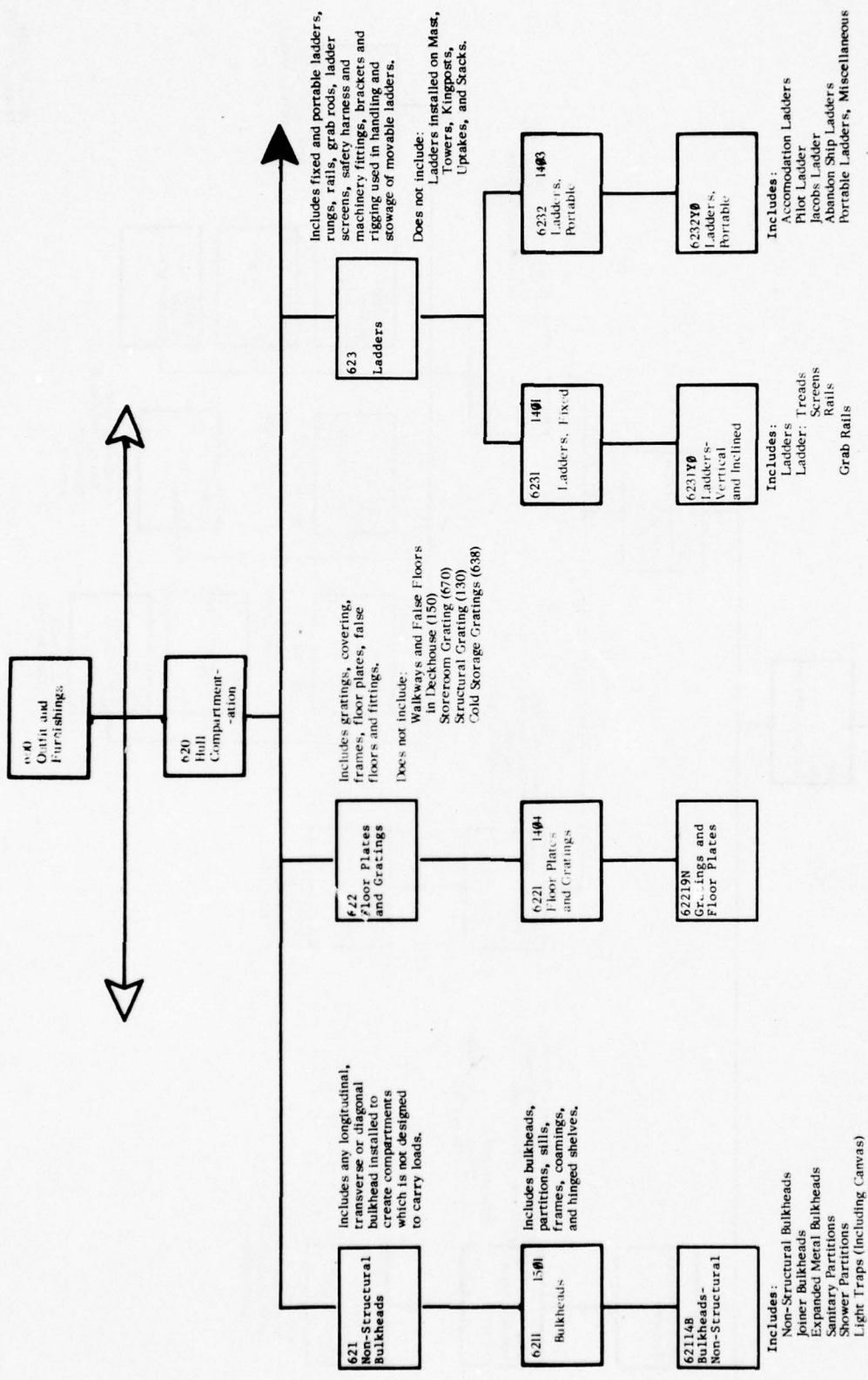

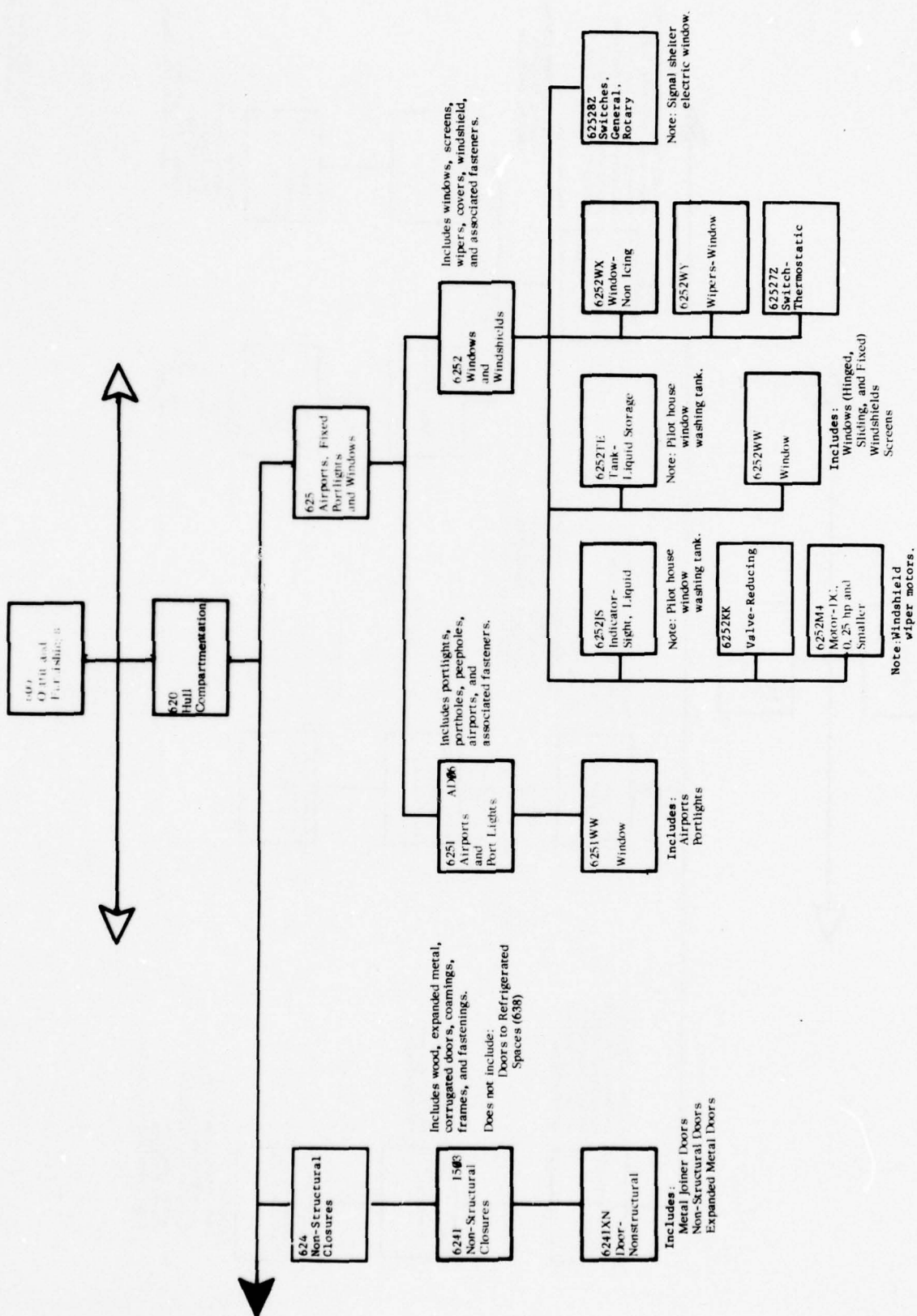

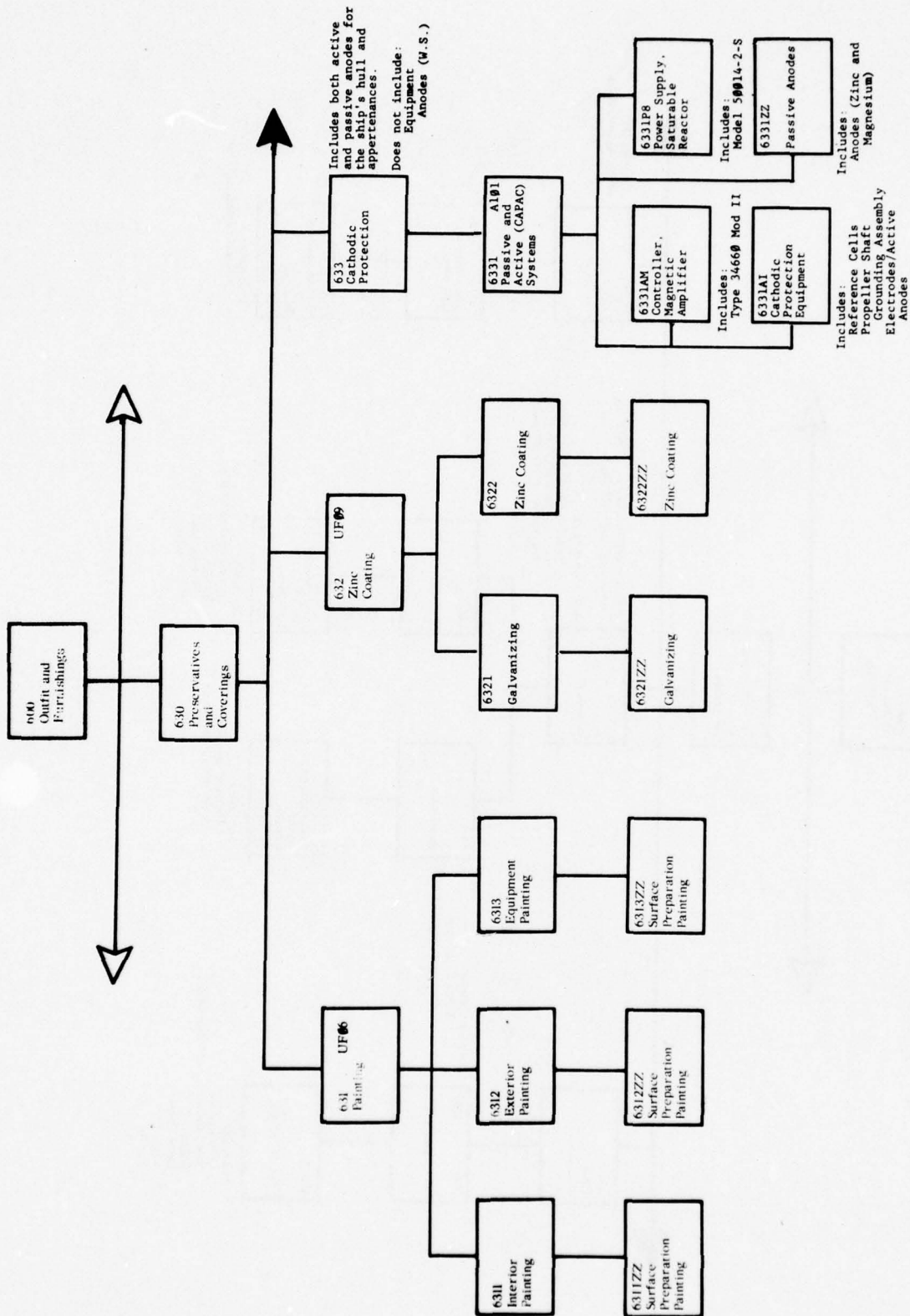

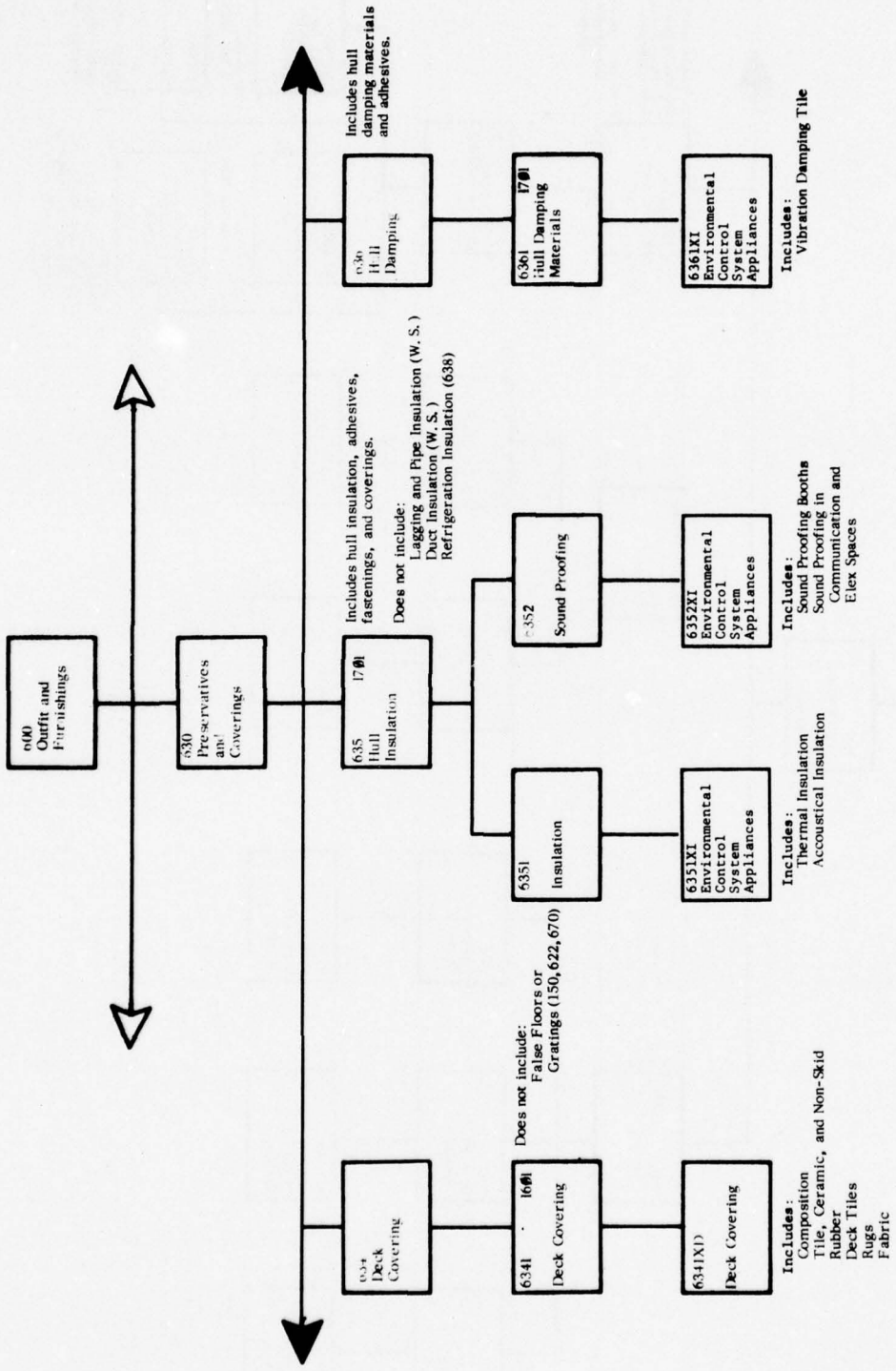

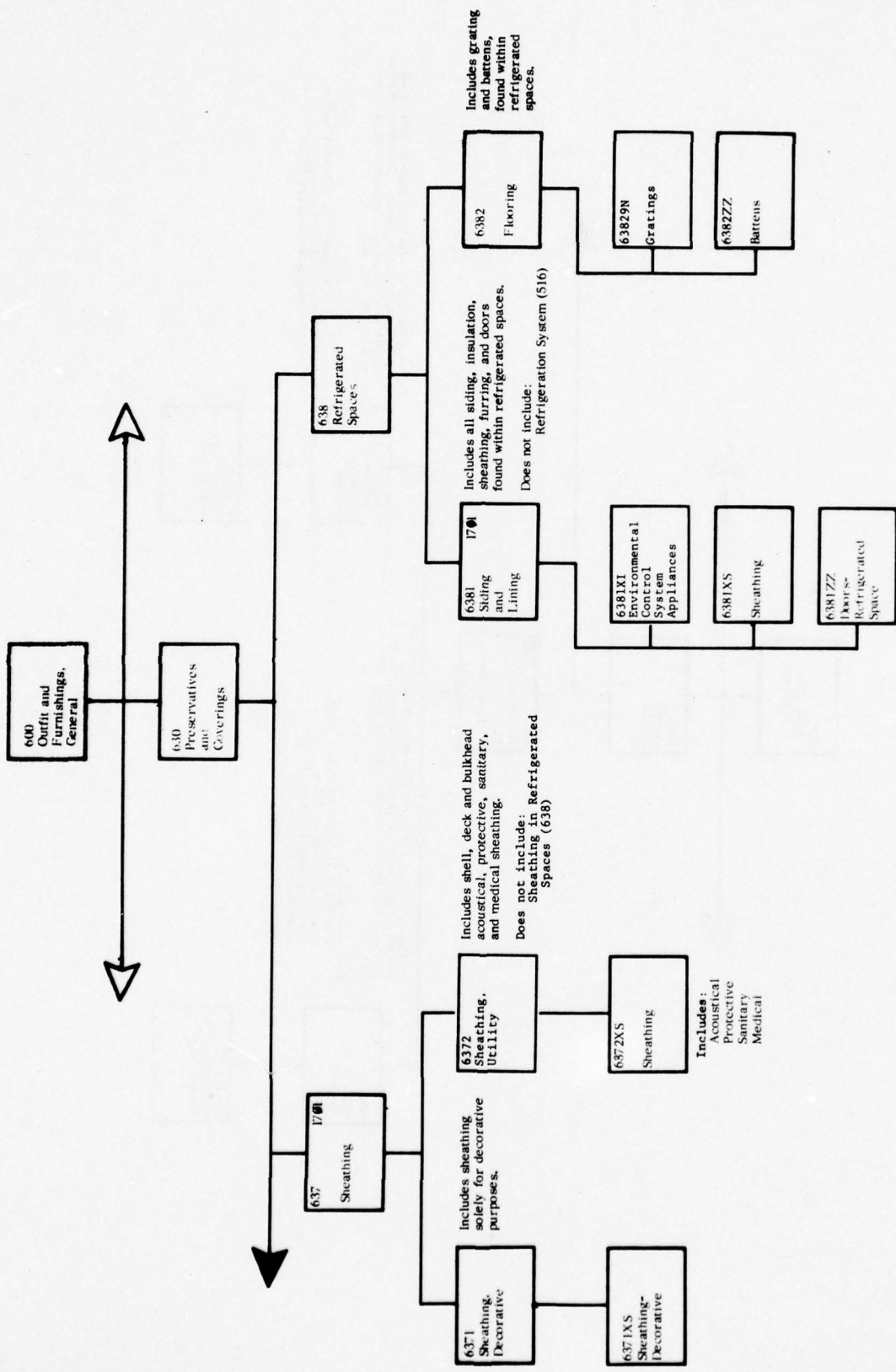

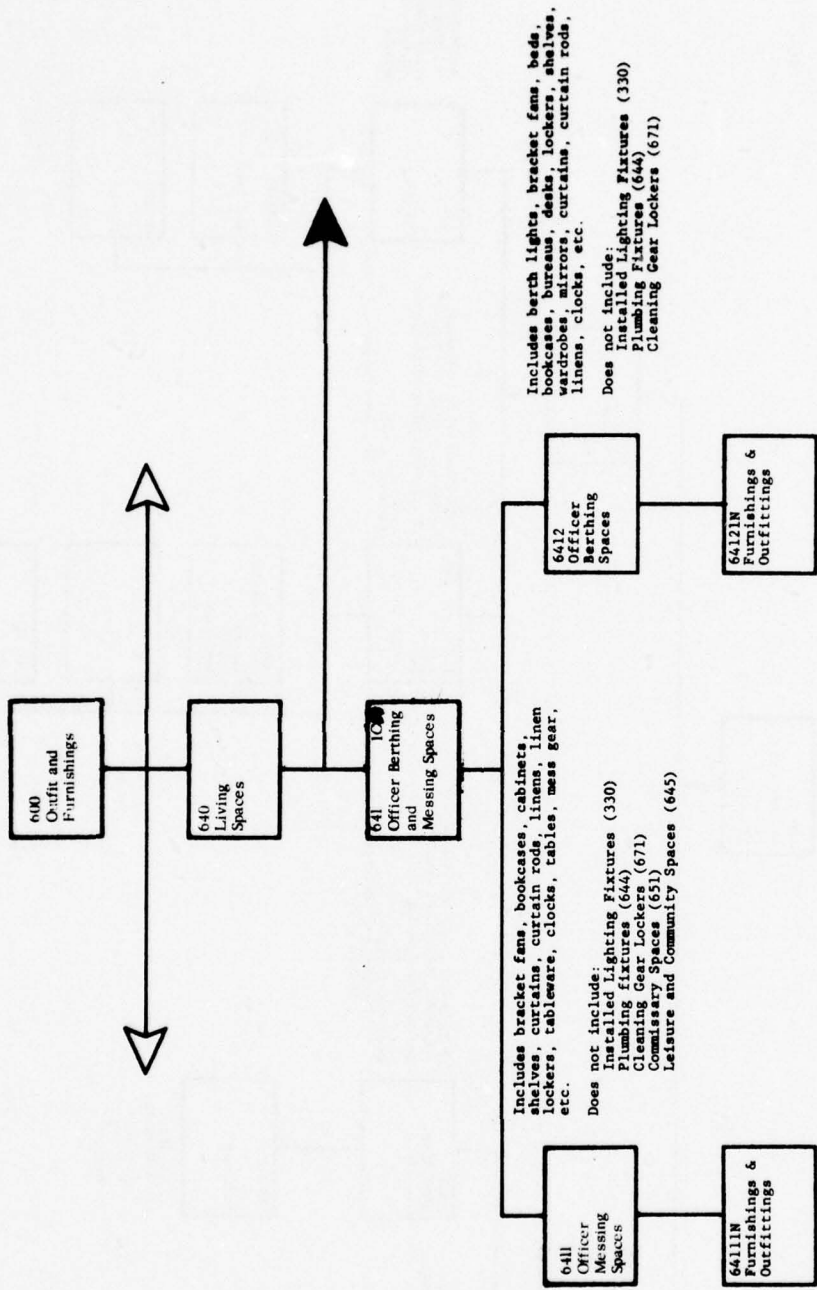

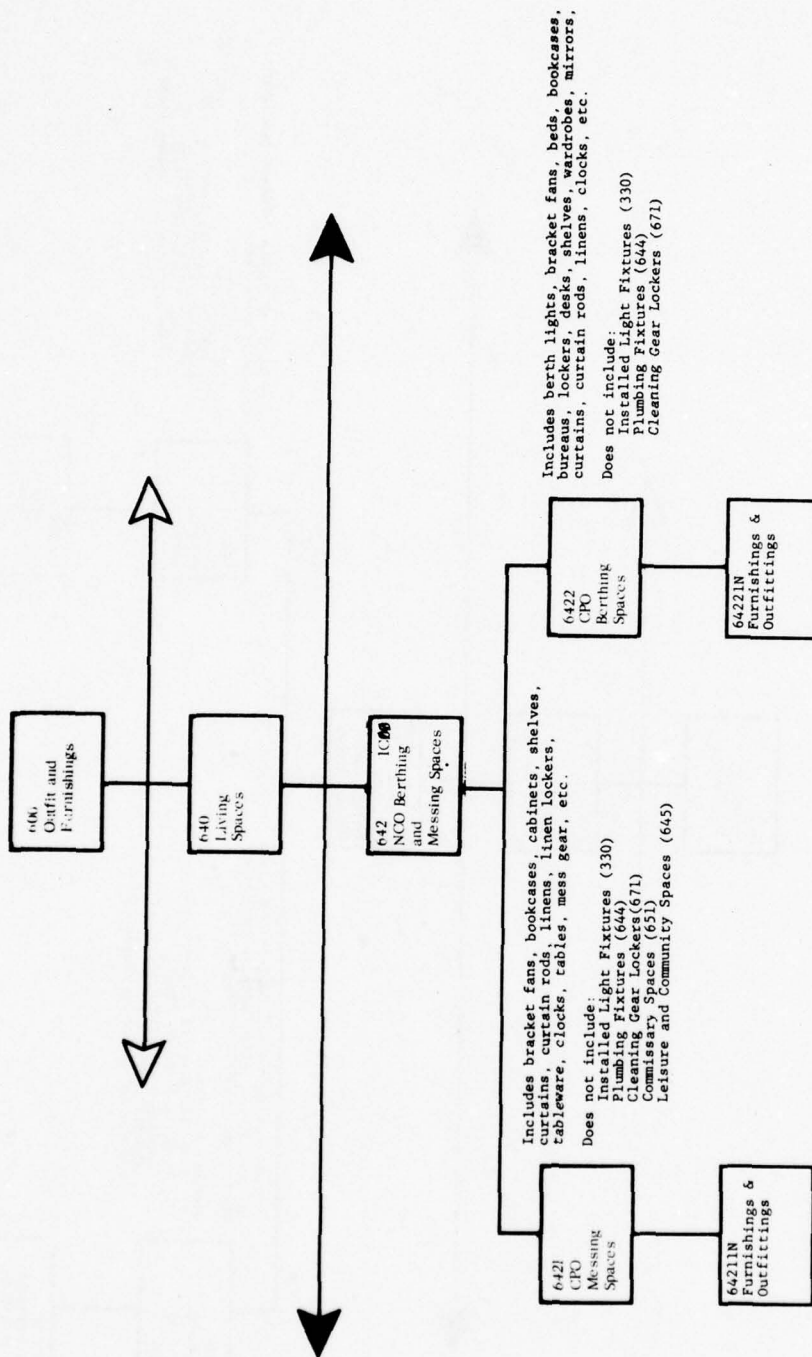

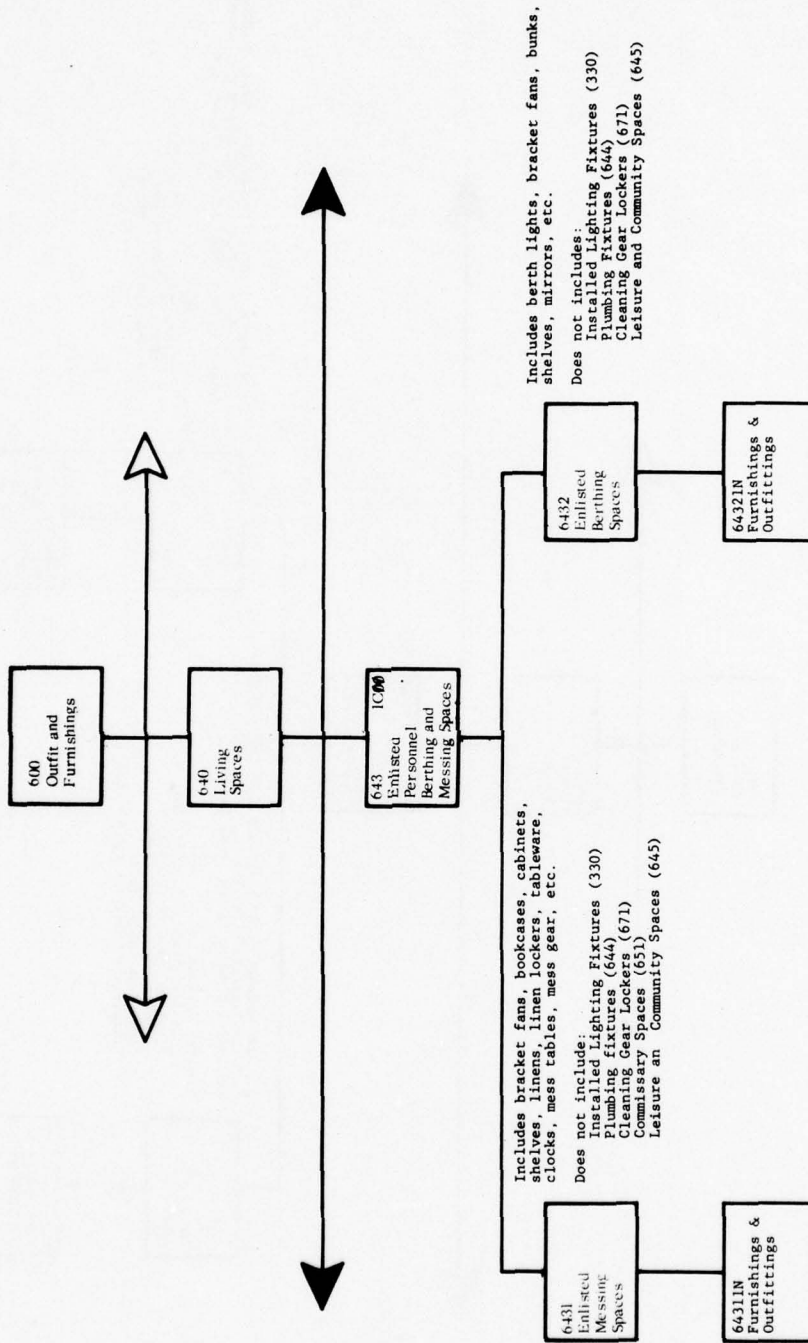

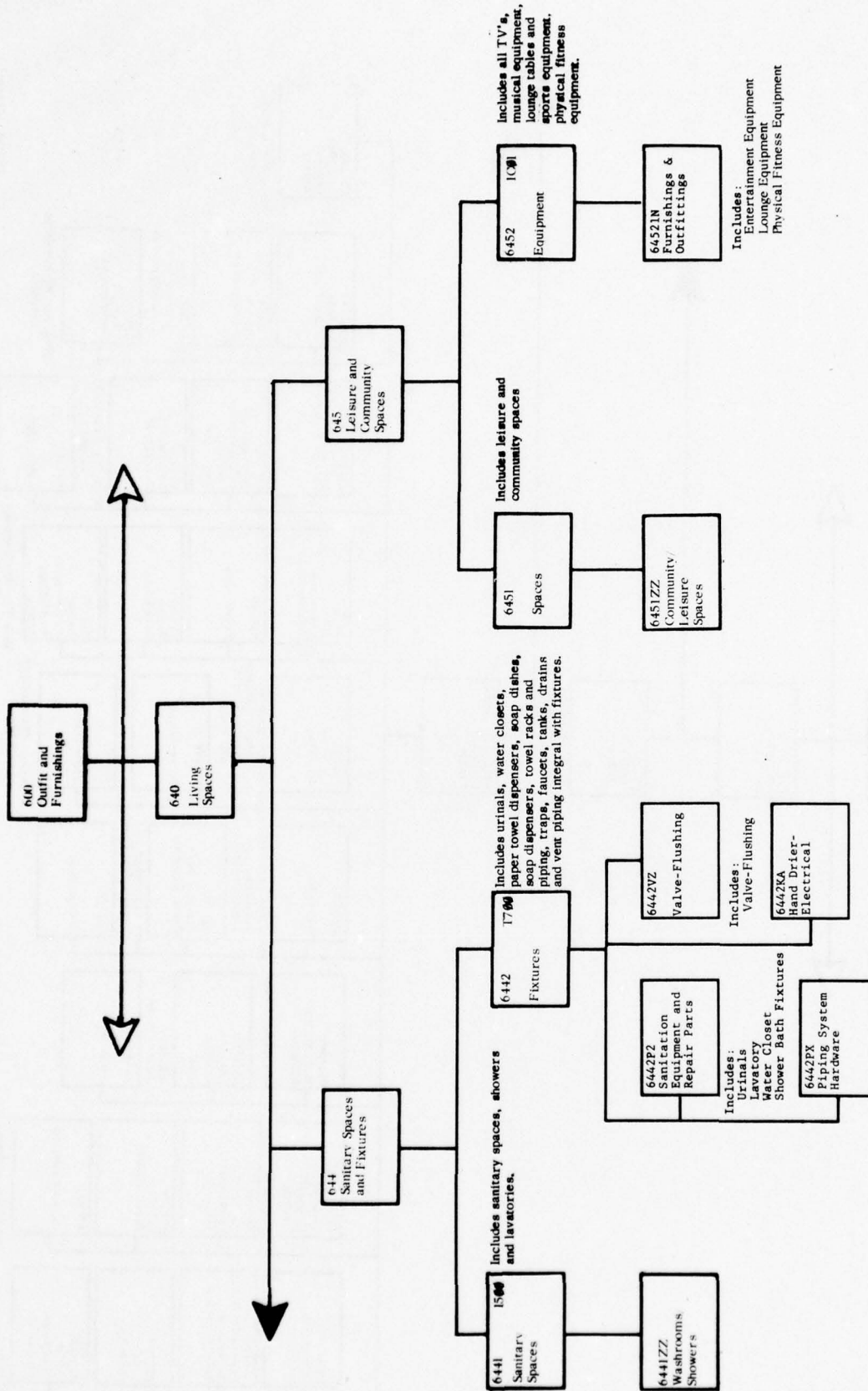

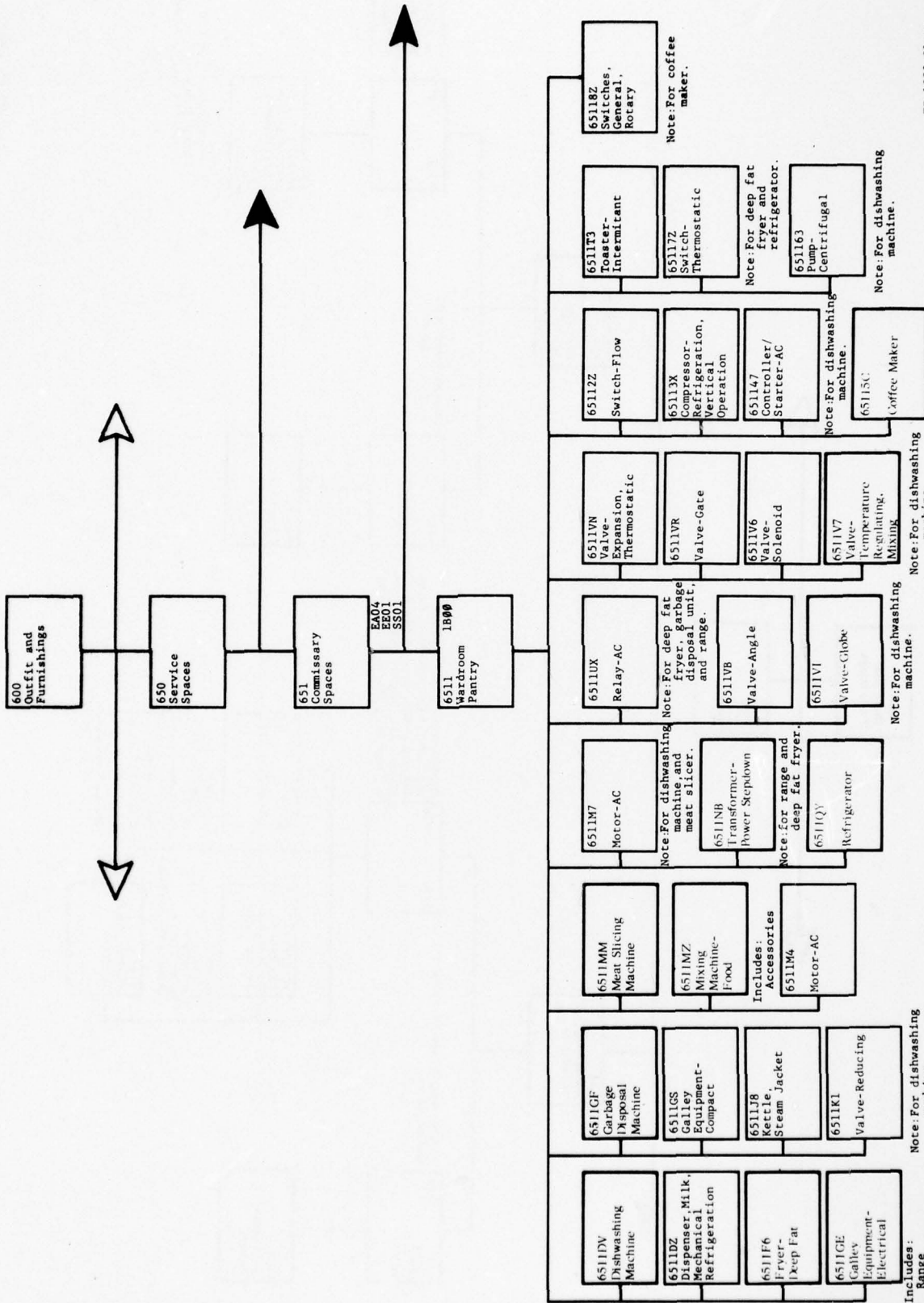

Includes:  
Range  
Self Heating Griddle  
Waffle Iron

Note: For dishwashing machine.

Note: For dishwashing machine.

Note: For dishwashing machine.

Note: For coffee maker.

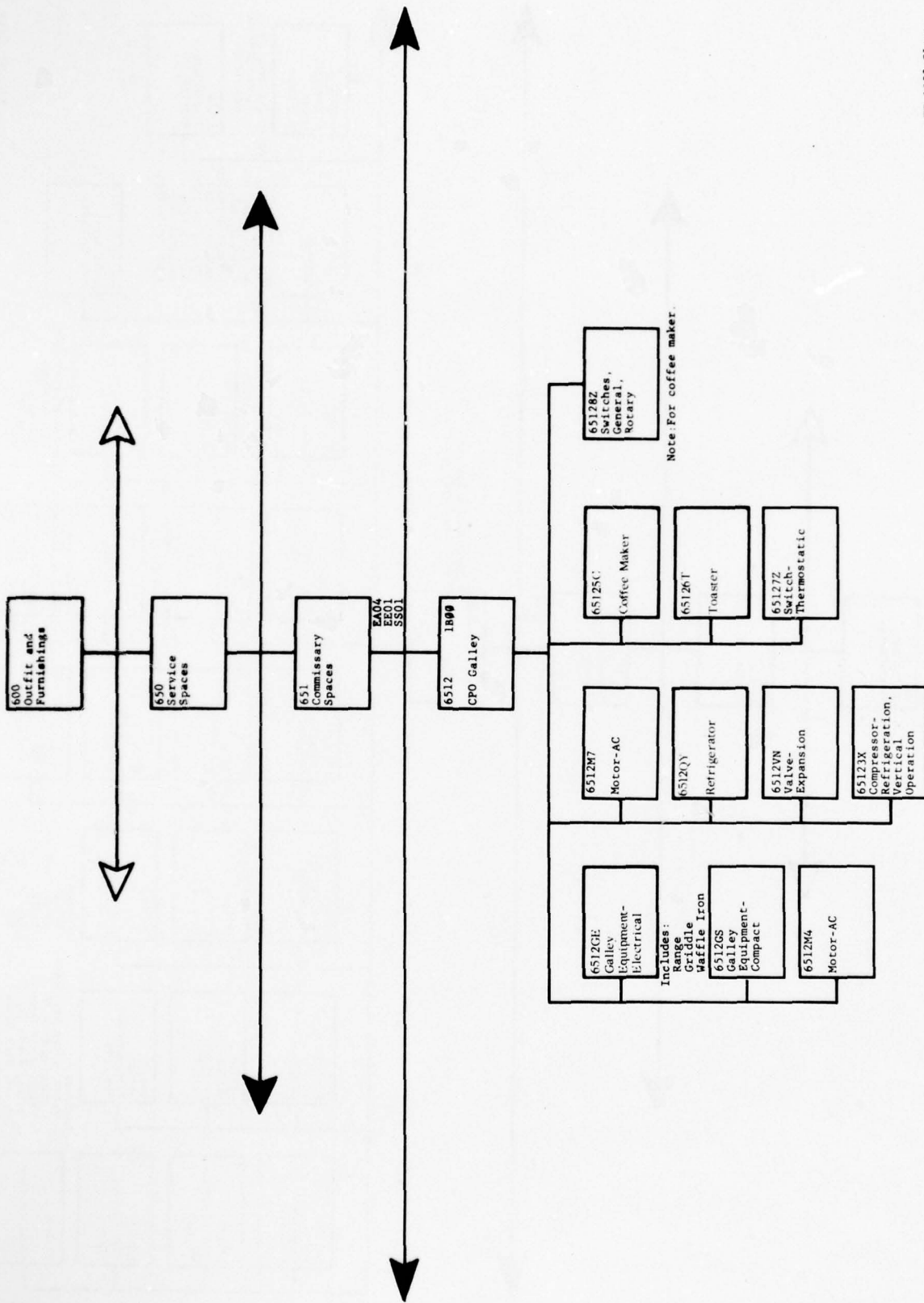

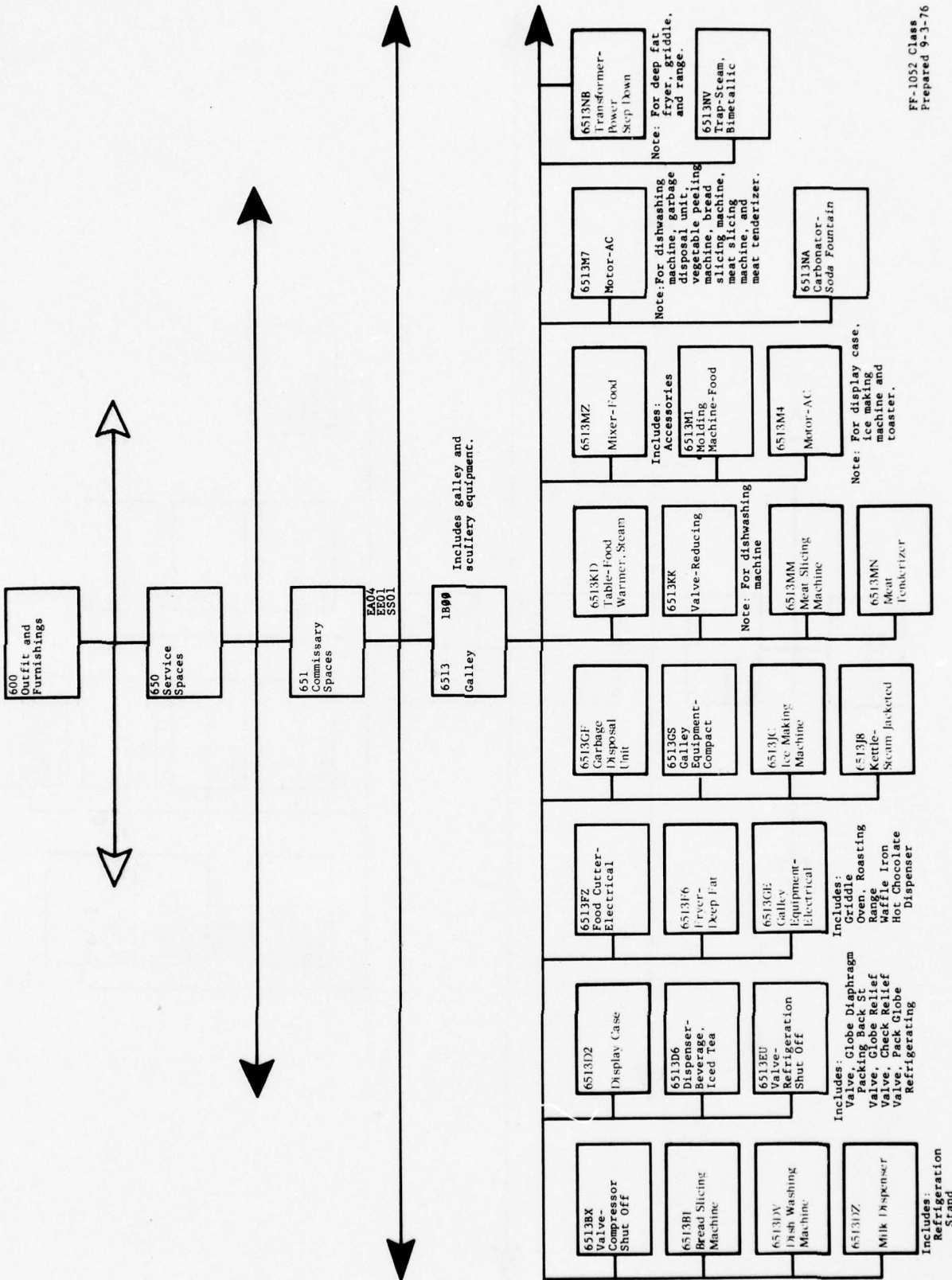

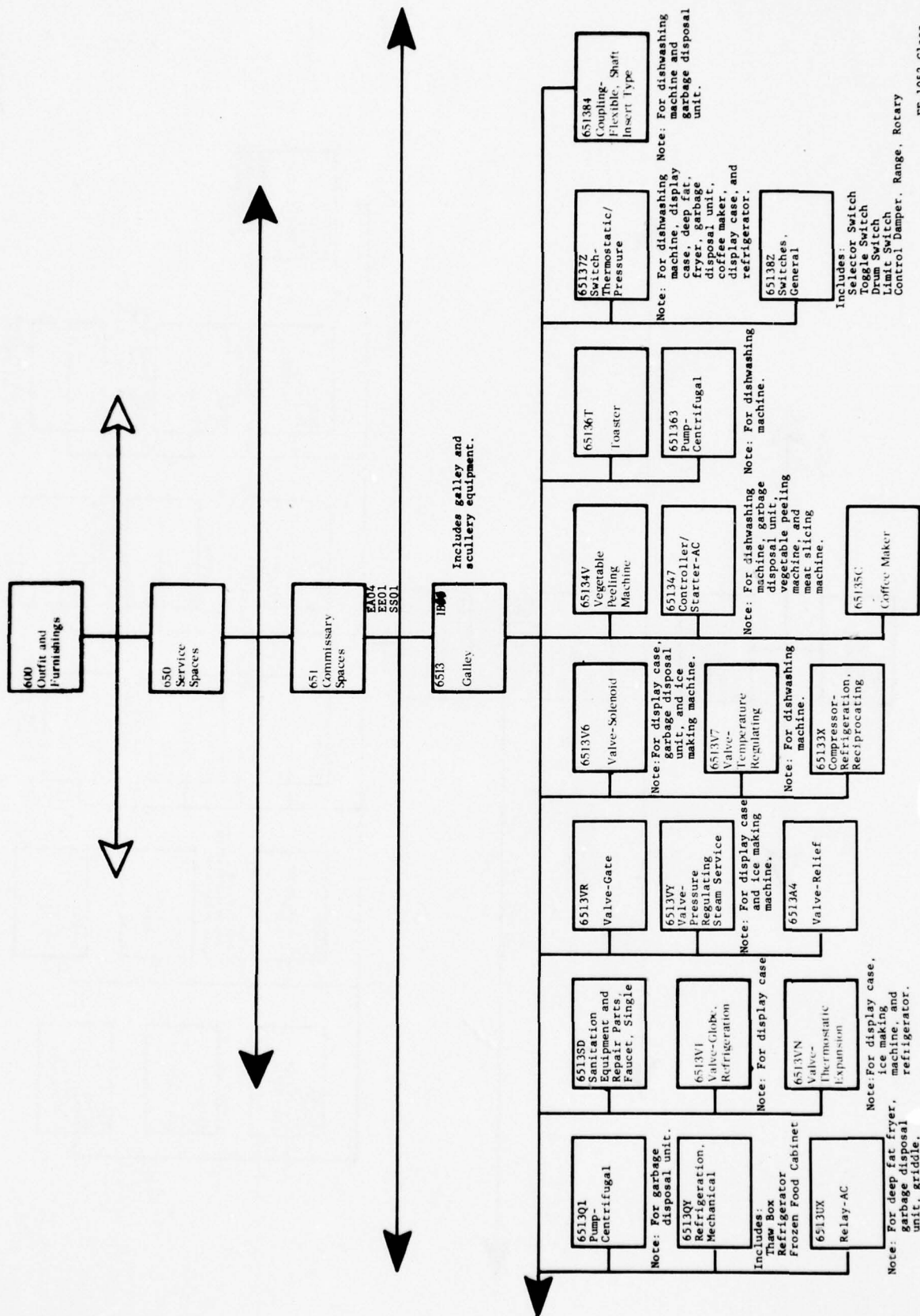

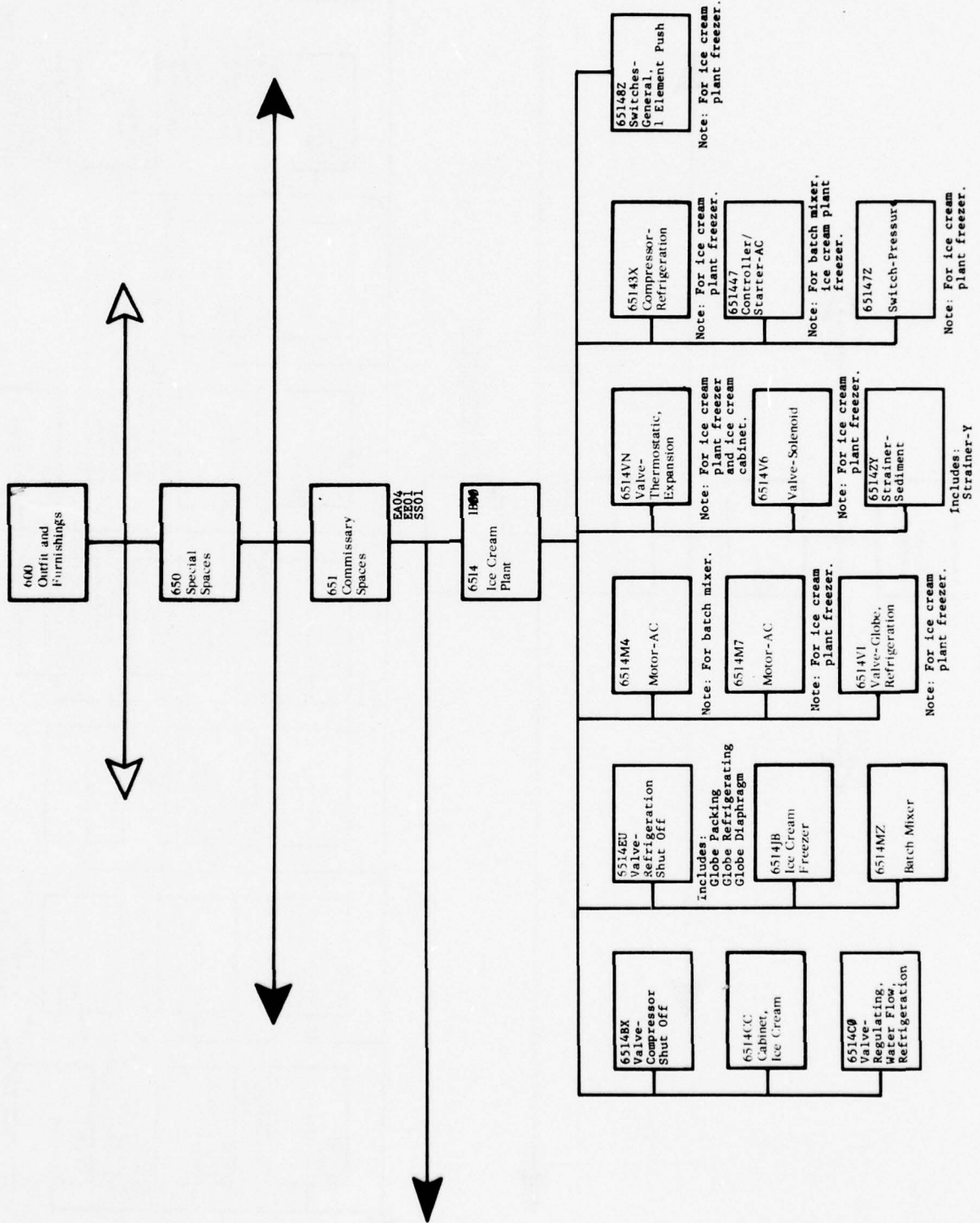

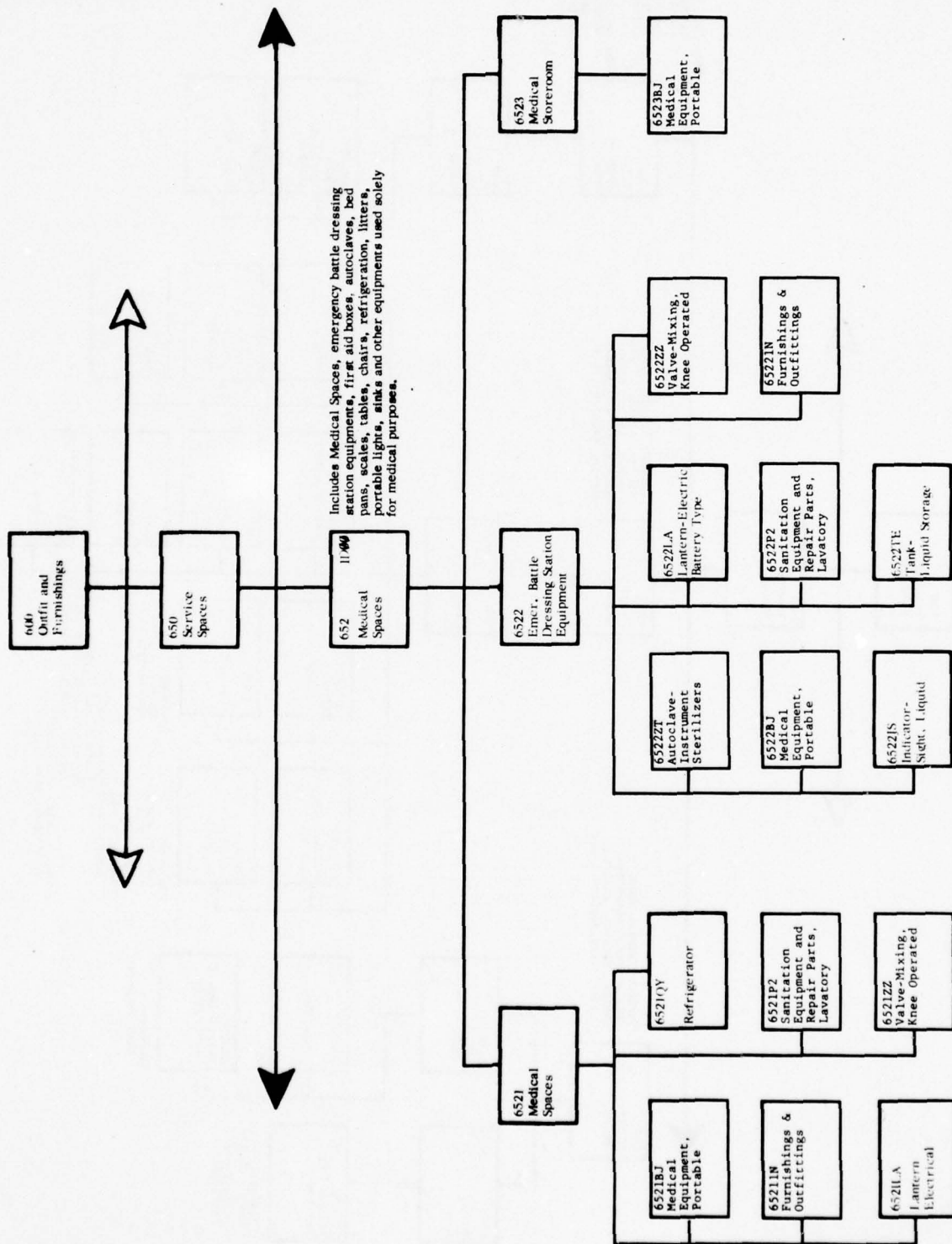

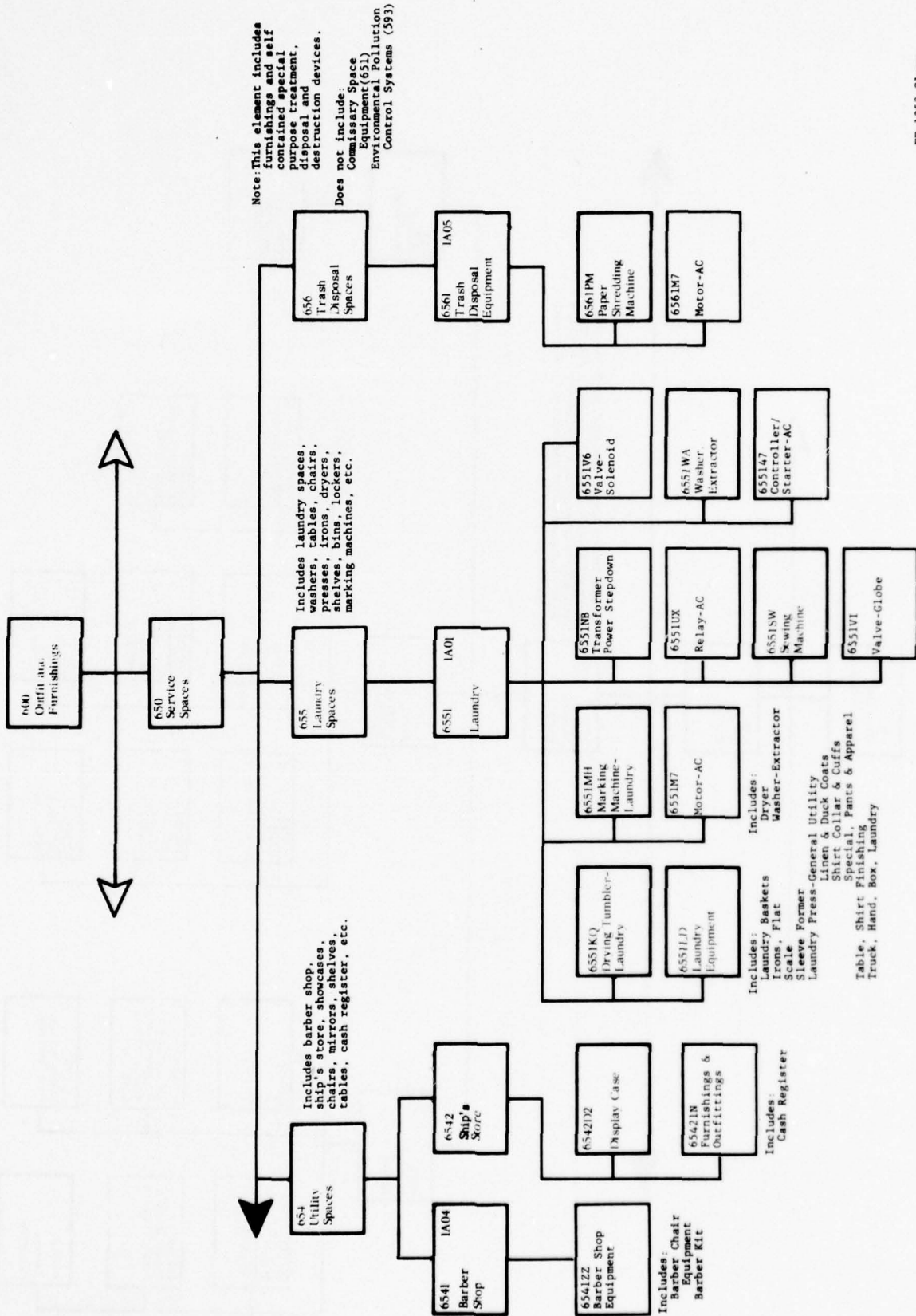

Note: This element includes furnishings and self contained special purpose treatment, disposal and destruction devices. Does not include: Comptrol Systems (593)

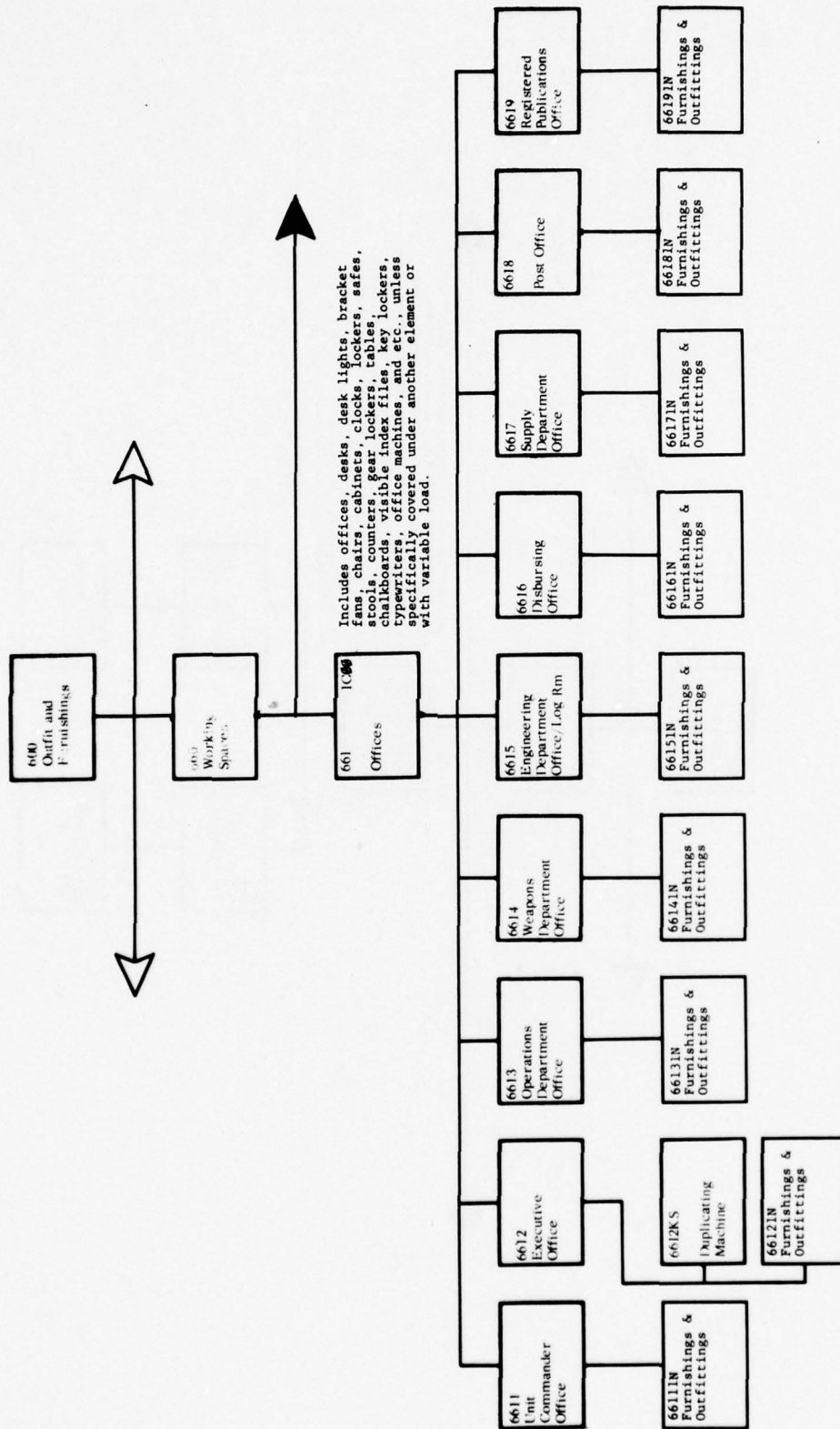

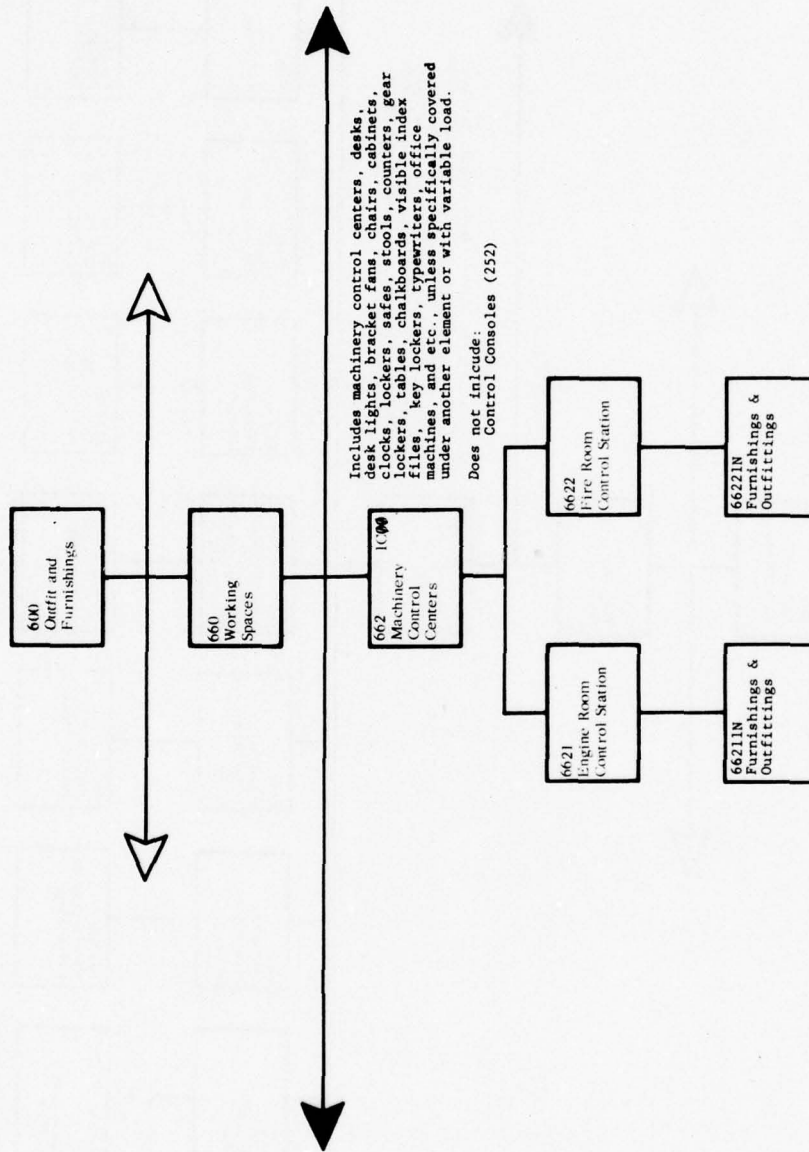

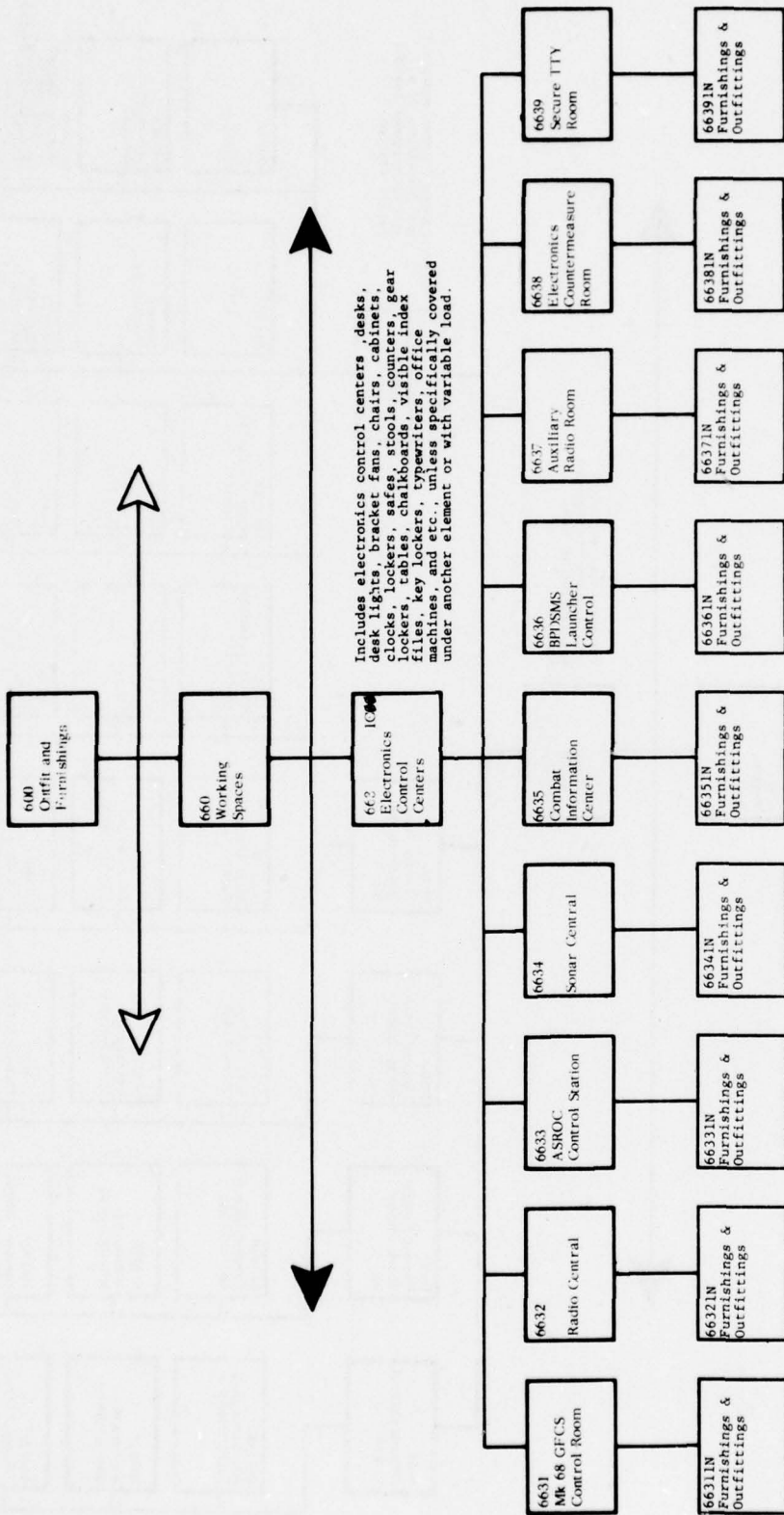

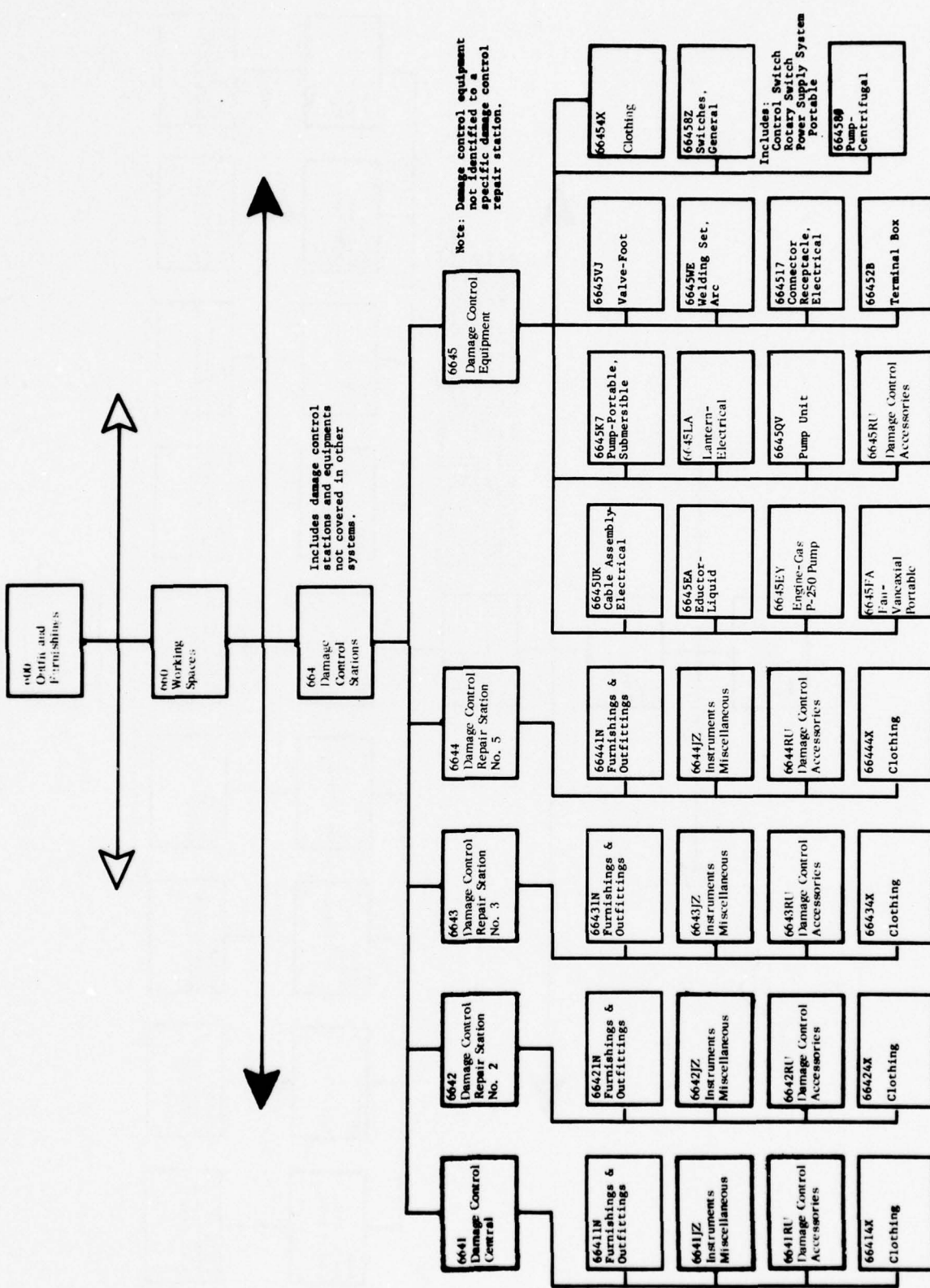

FF-1052 Class  
Prepared 9-3-76

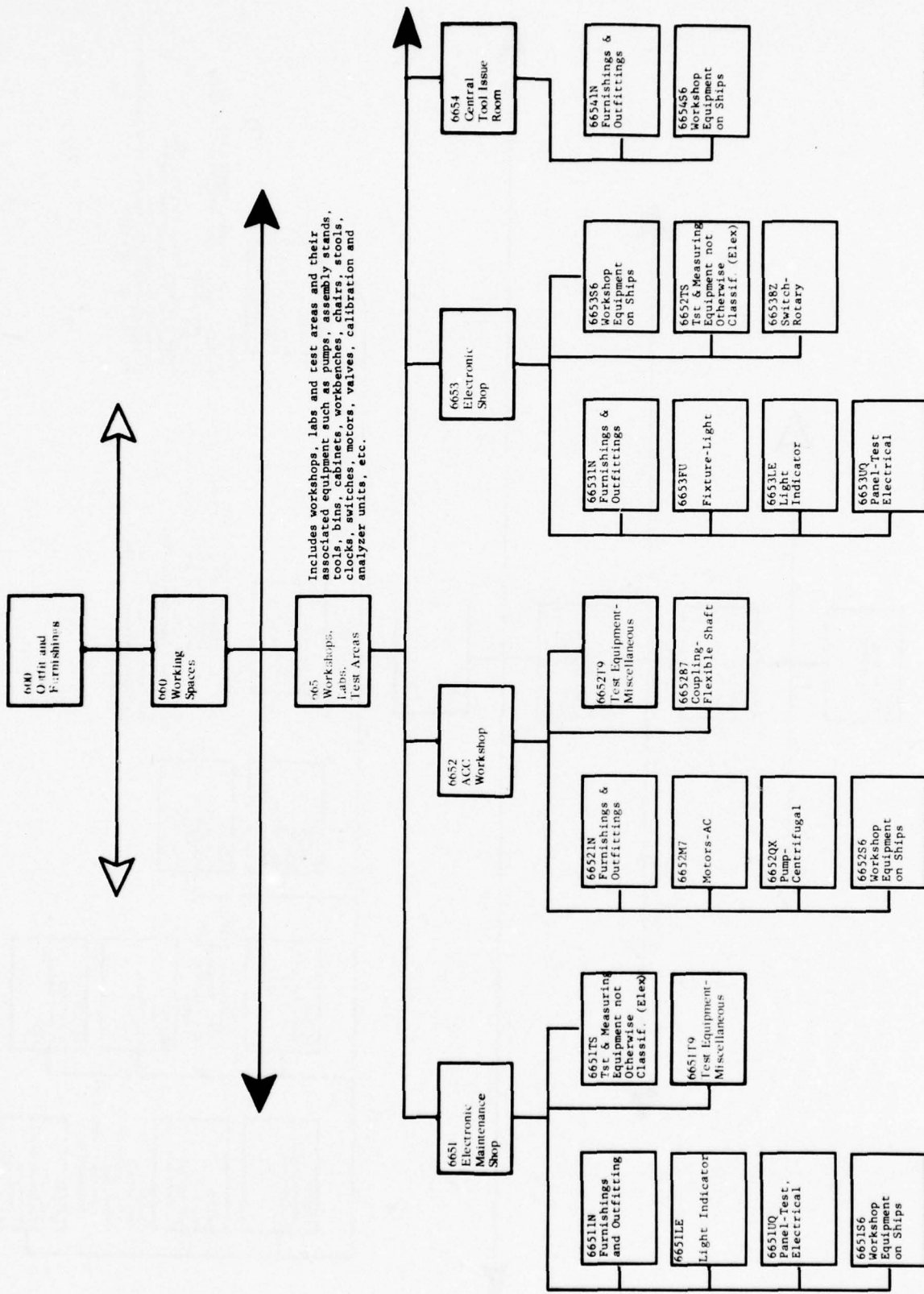

FF-1052 Class  
Prepared 9-3-76

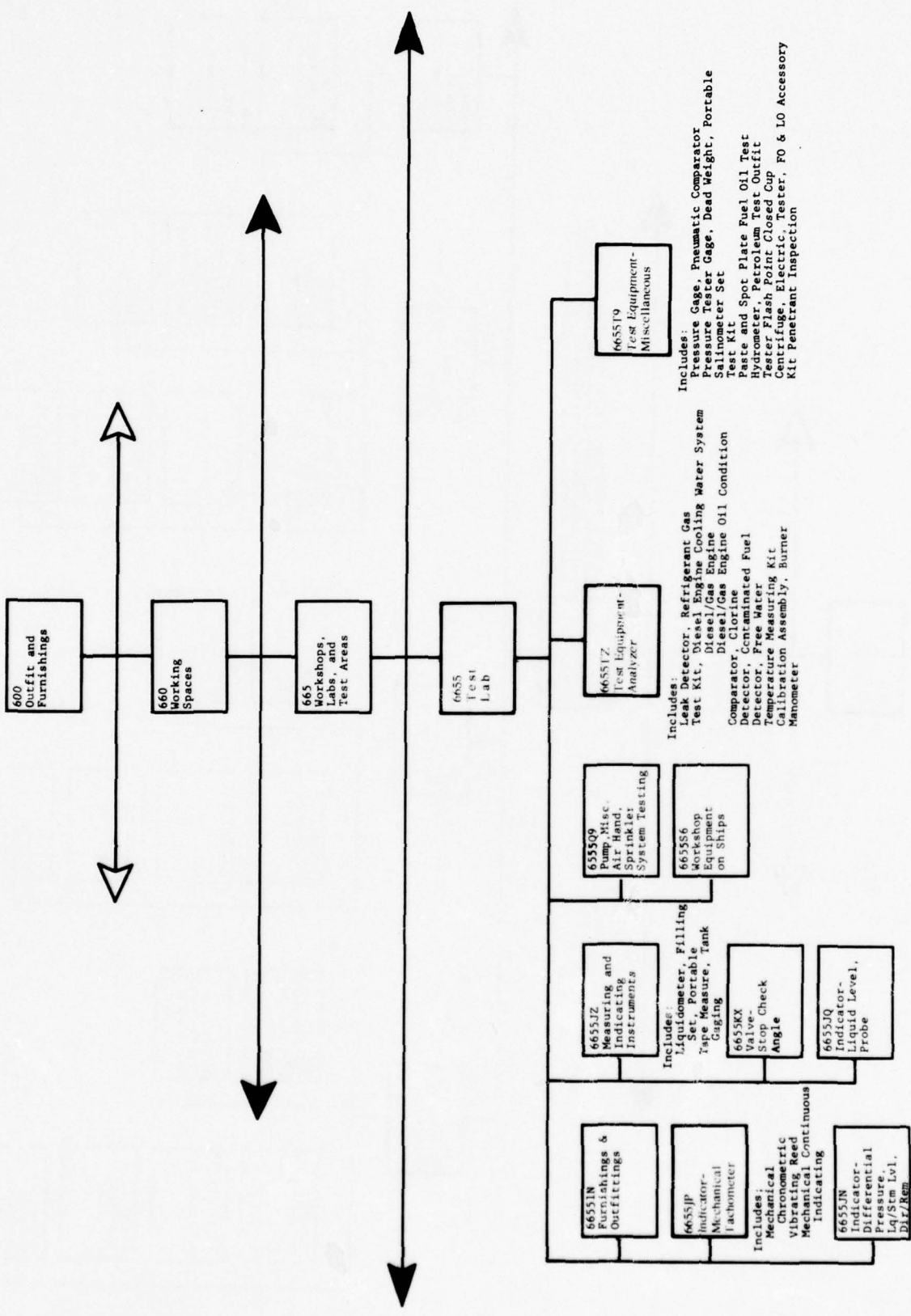

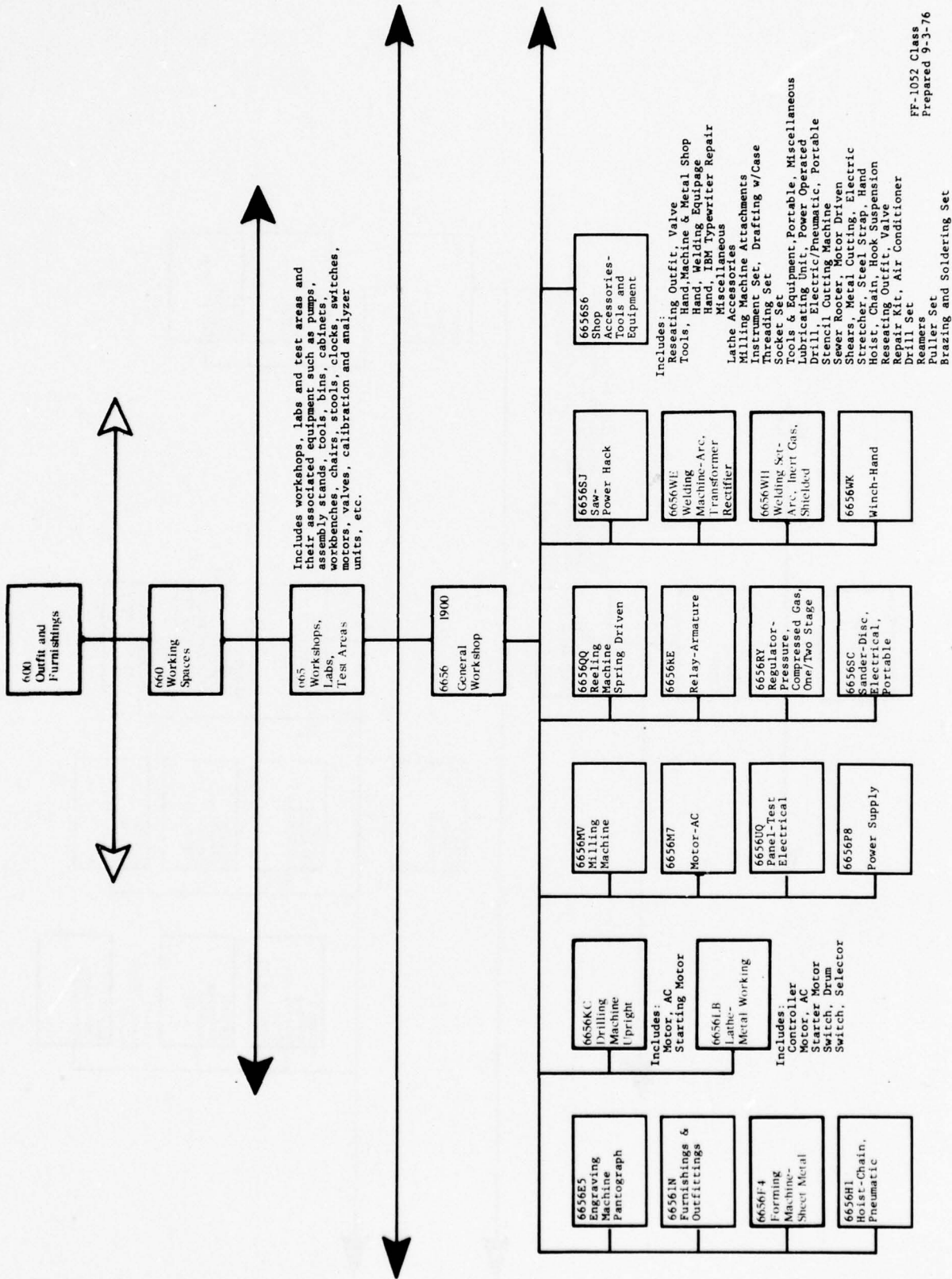

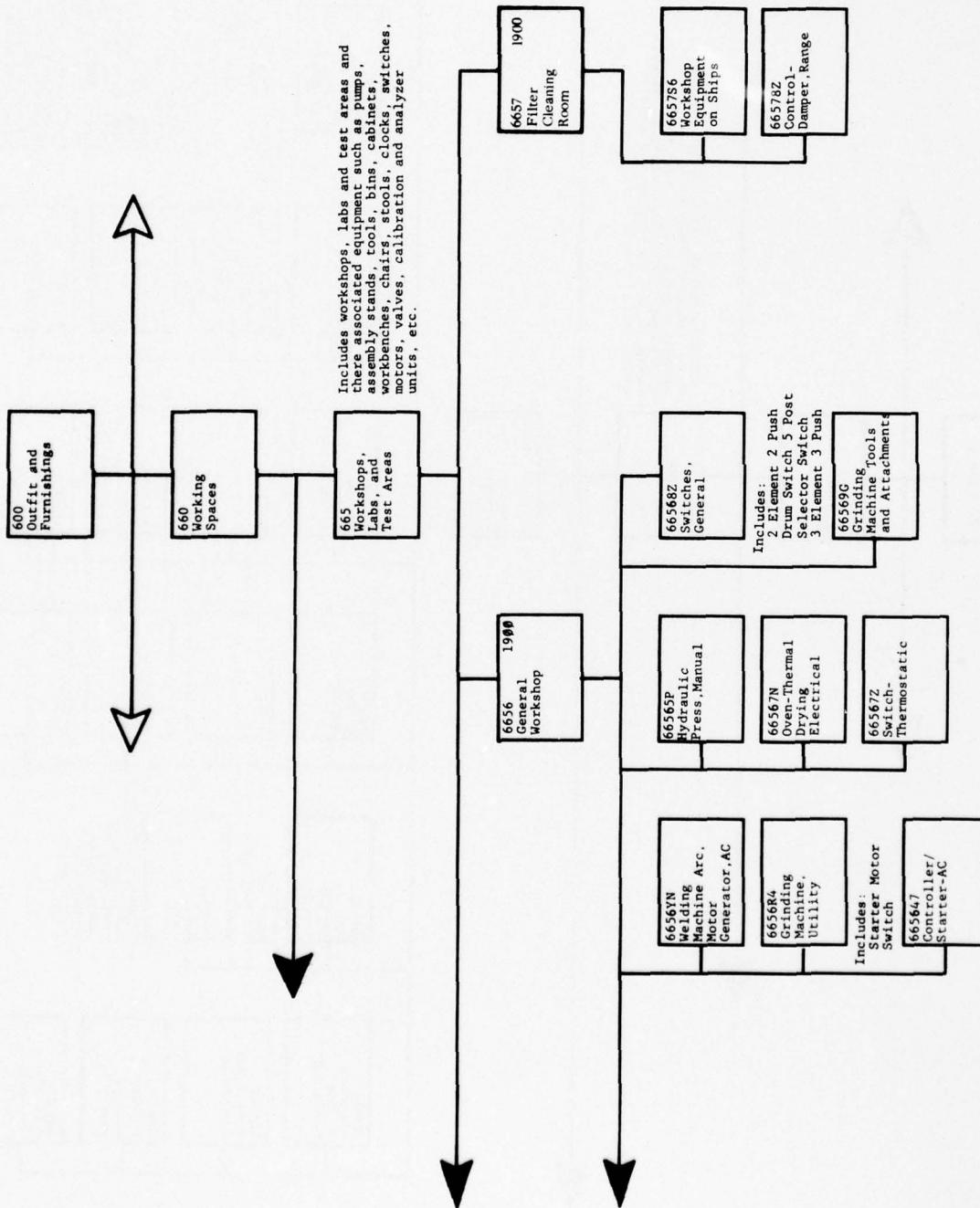

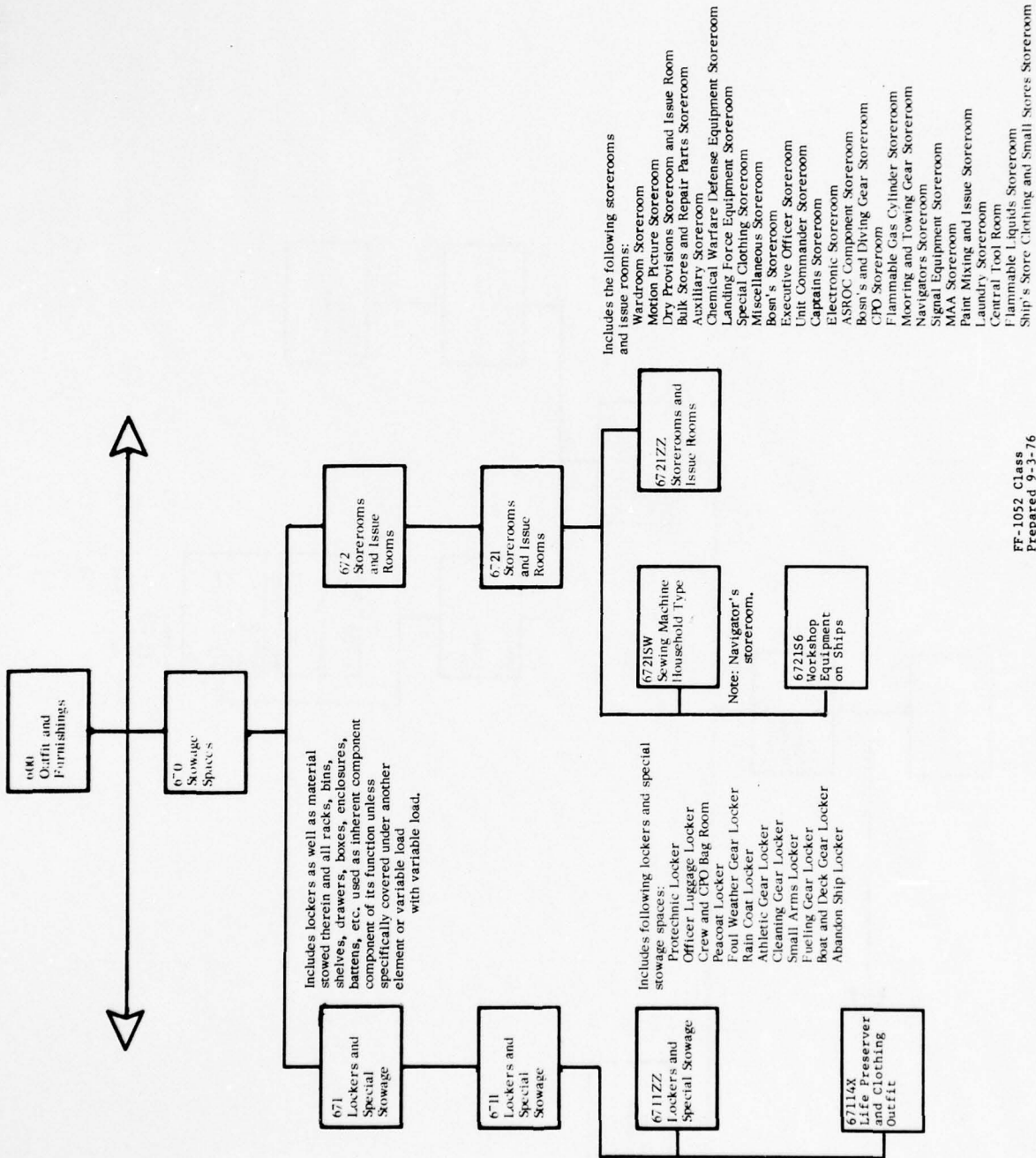

FF-1052 Class  
 Prepared 9-3-76

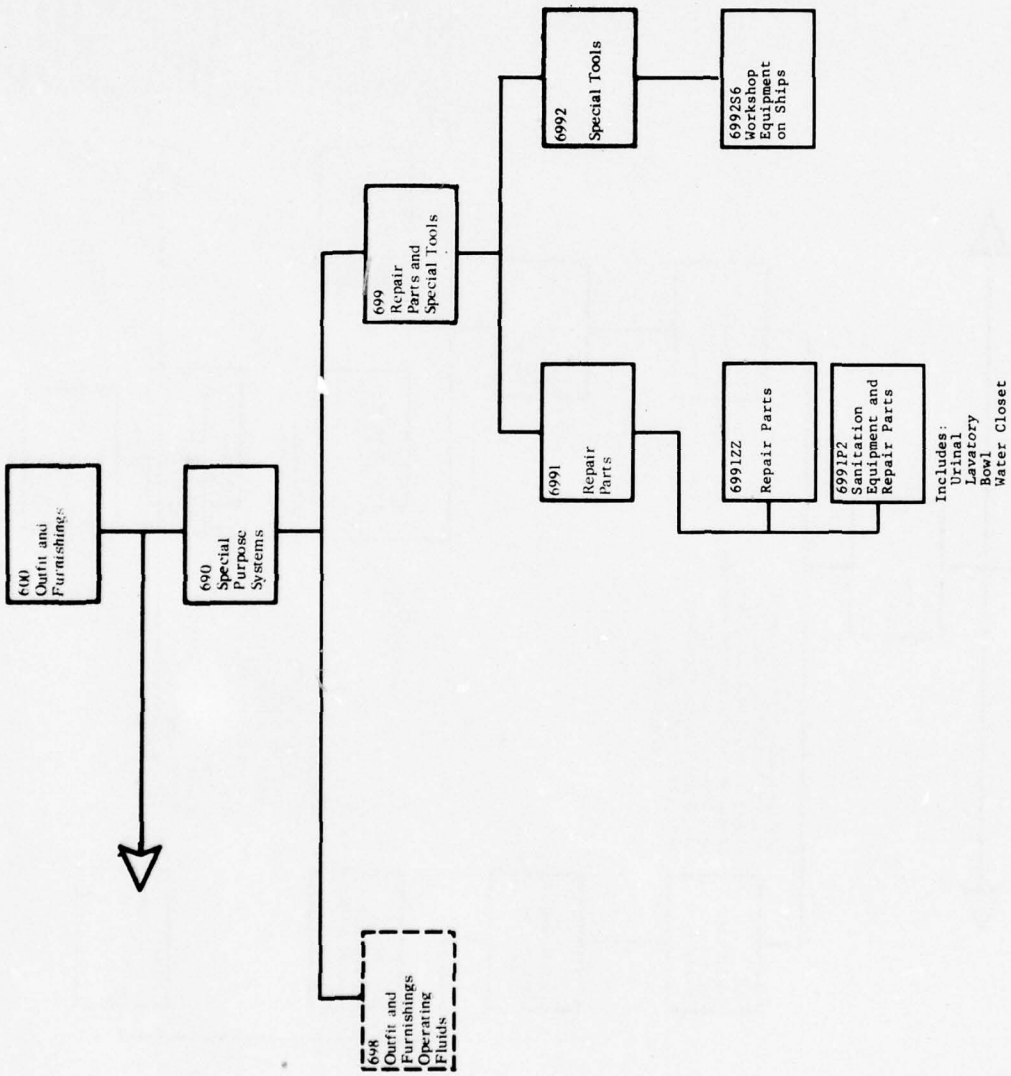

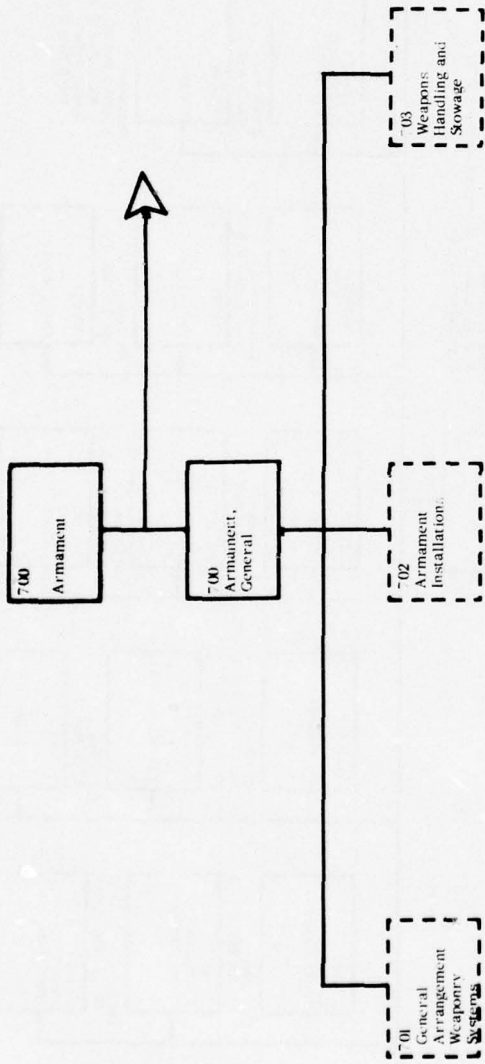

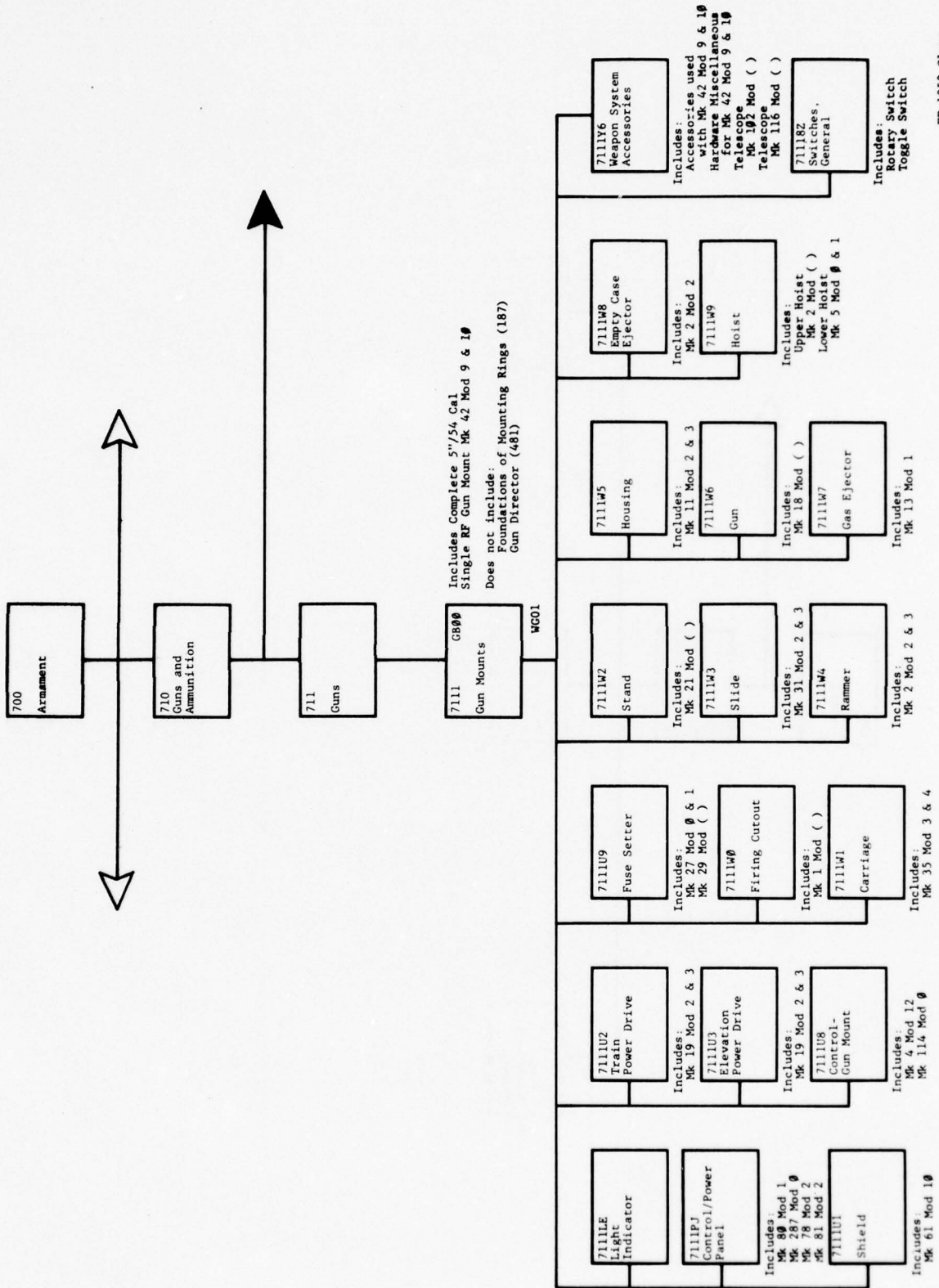

FF-1052 Class  
Prepared 9-28-76

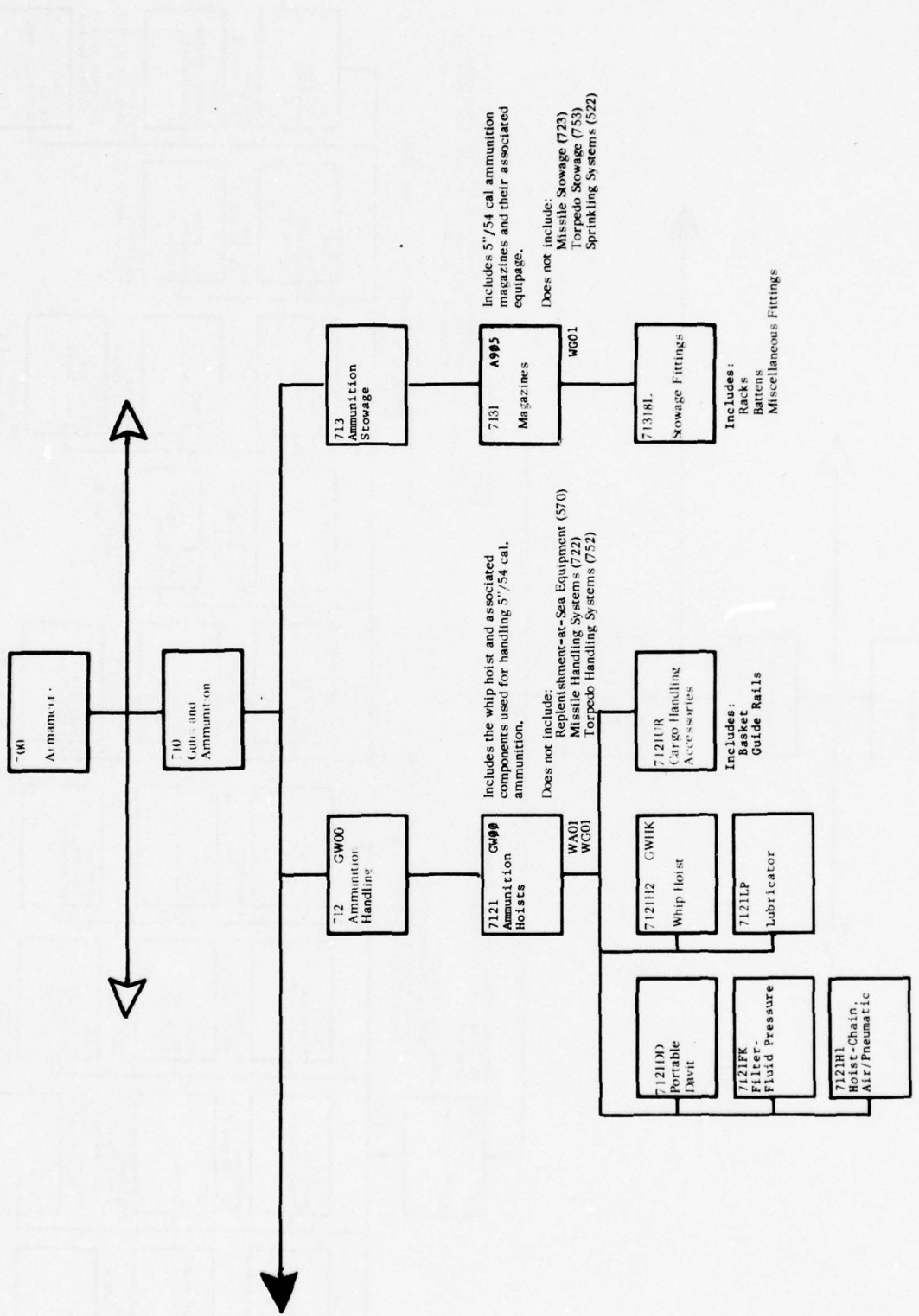

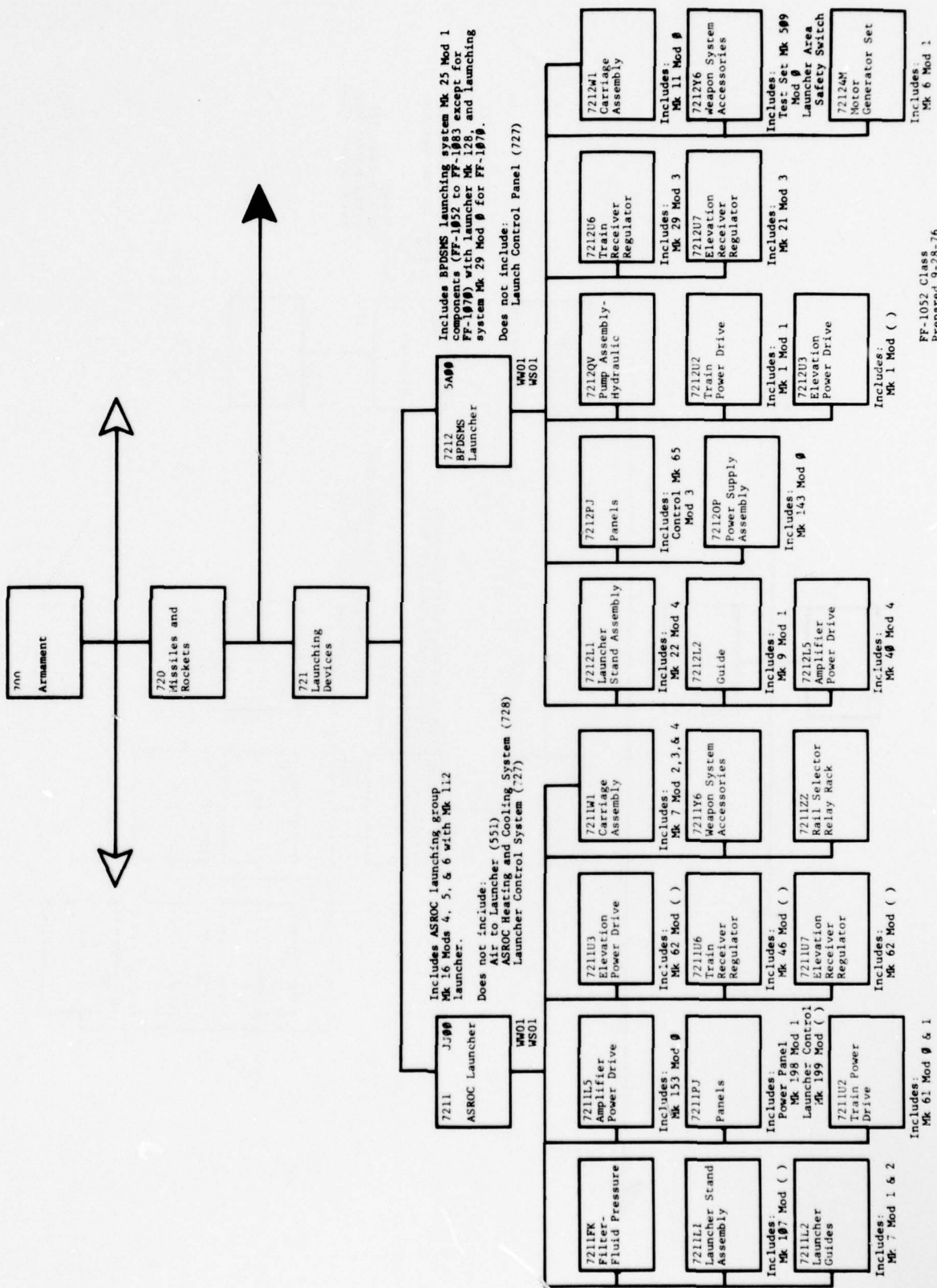

FF-1052 Class  
Prepared 9-28-76

