

AD-A052 534

ARINC RESEARCH CORP
DESIGN OF PROTOTYPE
JUN 72 K J BRAMAN
C42-01-1-1178

SANTA ANA CALIF WESTERN DIV
ASSEMBLIES IN SELECTED LINE

F/G 19/5
REPLACEABLE UNI--ETC(U)
F42600-72-D-0779
NL

UNCLASSIFIED

1 OF 1
ADA
052534

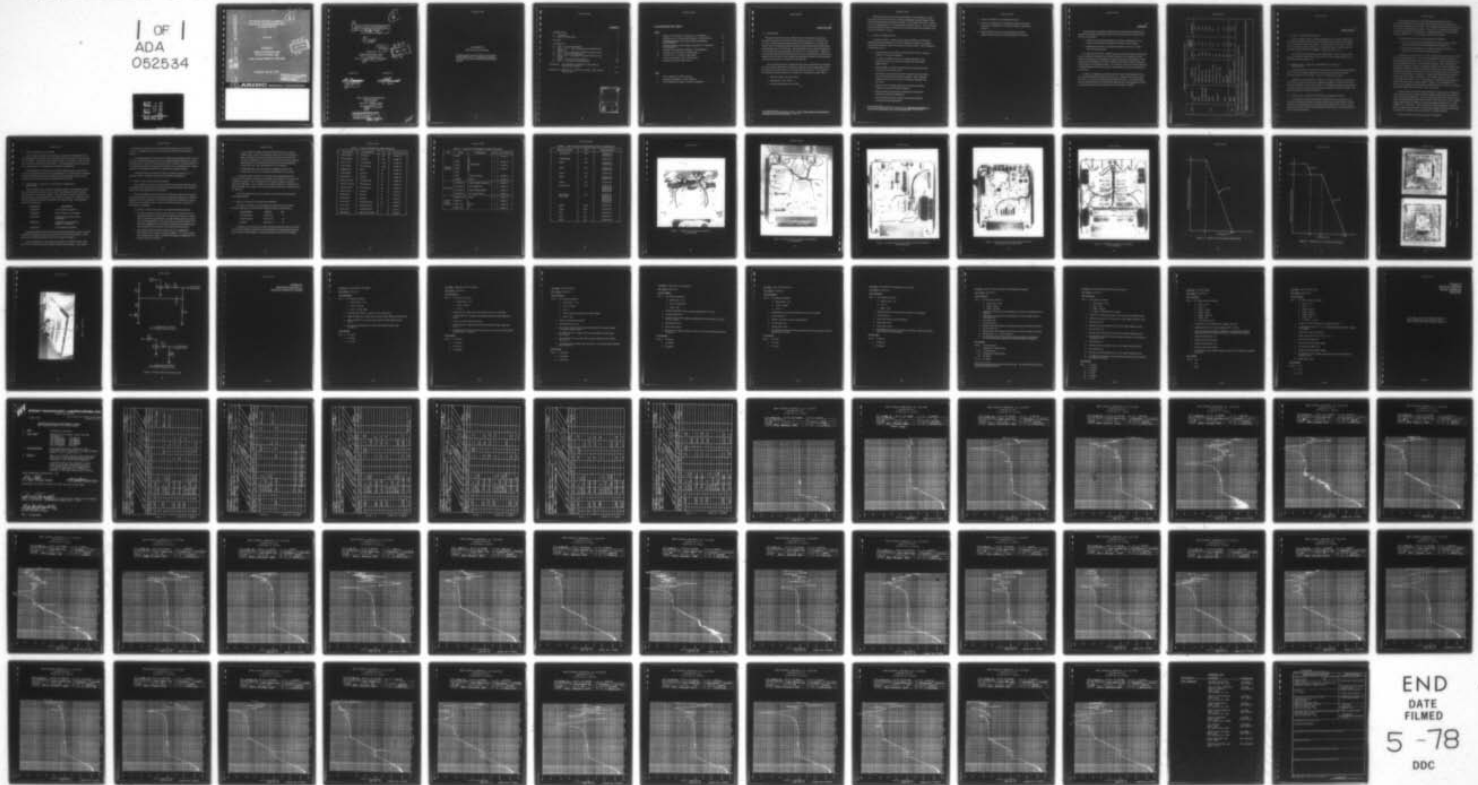

END
DATE
FILMED
5 -78
DDC

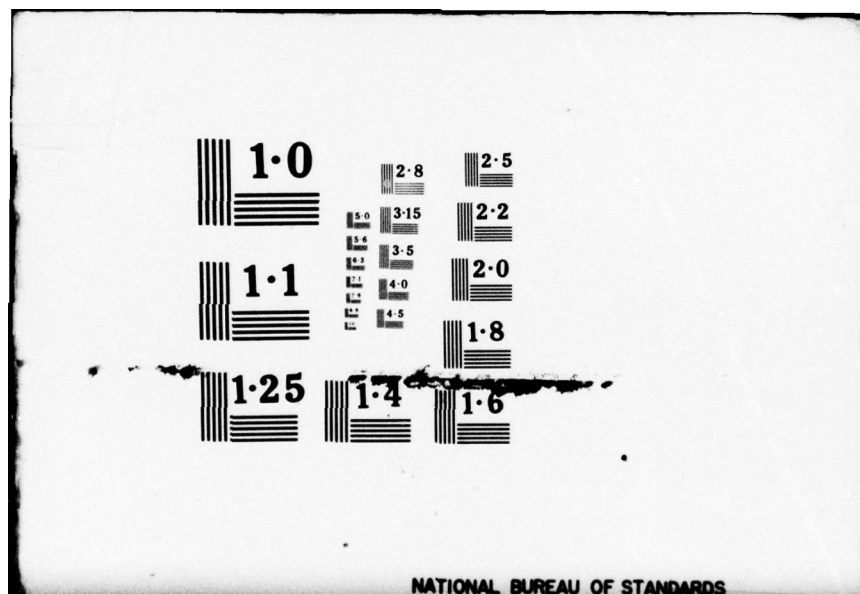

NATIONAL BUREAU OF STANDARDS

Dir. of APS

6
P.S.

AD A 052534

DESIGN OF PROTOTYPE ASSEMBLIES
IN SELECTED LINE REPLACEABLE UNITS
OF AN/APQ-109 FCS

June 1972

DDC
APR 11 1978
F

AD No. _____
DDC FILE COPY

Prepared for

OGDEN AIR MATERIEL AREA
Hill Air Force Base, Utah

Under Contract F42600-72-D-0779-0002

Publication C42-01-1-1178

This document has been approved
for public release and sale; its
distribution is unlimited.



ARINC RESEARCH CORPORATION

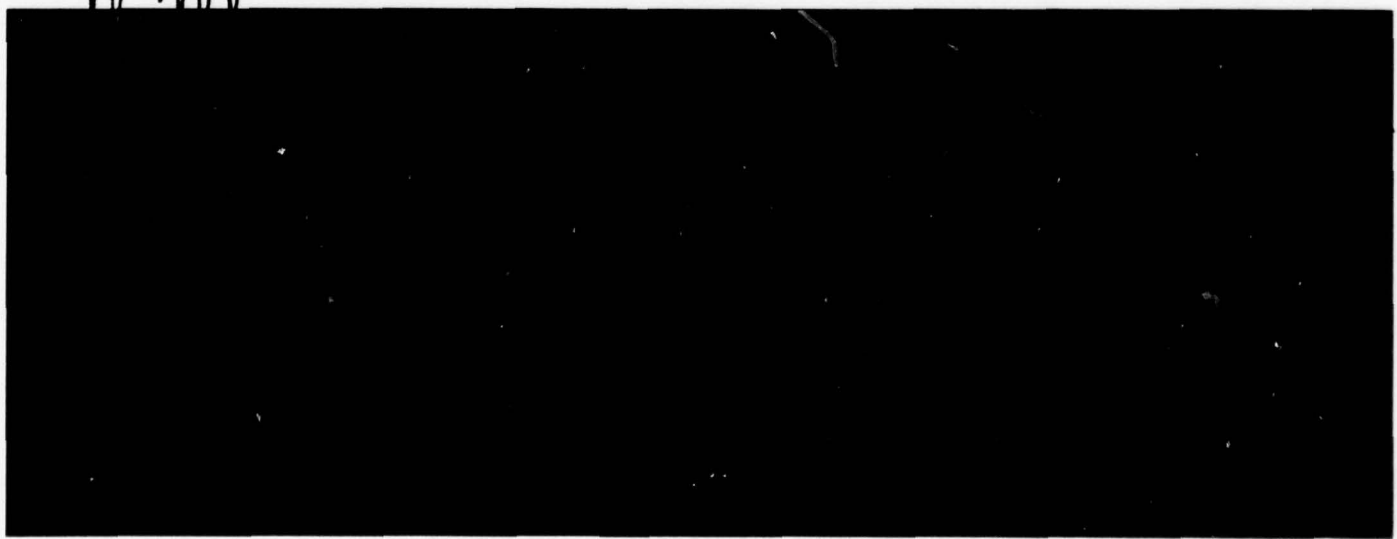

6

⑥
DESIGN OF PROTOTYPE ASSEMBLIES
IN SELECTED LINE REPLACEABLE UNITS
OF AN/APQ-109 FCS

⑪
June 1972

⑫ 82p.

DDC
APR 11 1978
RESOLVED
47 F

Prepared for
OGDEN AIR MATERIEL AREA
Hill Air Force Base, Utah
Under Contract F42600-72-D-0779-0002

⑬

Prepared by

Approved by

K.J. Braman
K.J. Braman
⑩

W.P. Reeves
W.P. Reeves

ARINC RESEARCH CORPORATION
Western Division
P. O. Box 1375
Santa Ana, California 92702
Publication C42-01-1-1178

⑭

This document has been approved
for public release and sale; its
distribution is unlimited.

406 547

YB

C42-01-1-1178

Copyright © 1972

ARINC Research Corporation

Prepared under Contract F42600-72-D-0779-0002,
which grants to the U. S. Government a license to
use any material in this publication for government
purposes.

CONTENTS

1. INTRODUCTION. 1
1.1 Background 1
1.2 Scope of Present Study 2
2. SUMMARY 5
3. TASK RESULTS. 7
3.1 Task 1 — Parts Determination
3.2 Tasks 2 and 8 — Parts and Equipment Procurement and Delivery 7
3.3 Tasks 3 and 4 — Electrical Prototype Assurance Tests. 7
3.4 Task 5 — Mechanical Redesign. 9
3.5 Tasks 6 and 7 — Mechanical Prototype Fabrication and Testing. 9
3.6 Task 9 — Test Plans and Procedures. 10
3.7 Task 10 — Prototype Fabrication Support 11
APPENDIX A: PROCEDURES AND RESULTS, ELECTRICAL PROTOTYPE TESTING A-1
APPENDIX B: RESULTS OF VIBRATION TESTING, MECHANICAL PROTOTYPES B-1

ACCESSION for	
NTIS	<input checked="" type="checkbox"/>
DDC	<input type="checkbox"/>
UNANNOUNCED	<input type="checkbox"/>
J.S. PROPERTY	
DISSEMINATION/AVAILABILITY NOTES	
SIGNAL	
A	-

ILLUSTRATIONS AND TABLES

Figure

1	Modified A-Gun Deflection Amplifier, P/N 501R327G02	15
2	Modified 940-Hz Oscillator and Modulator, P/N 501R329G01	16
3	Modified Range Rate and Elevation Strobe Demodulator, P/N 501R333G03	17
4	Modified Acquisition Symbol Range and R-Min, R-A Generator, P/N 501R342G03	18
5	Modified B-Gun Deflection Amplifier, P/N 501R343G02	19
6A	Vibration Curve AR (Used for Initial Sweep)	20
6B	Vibration Curve G (Used for Final Sweep)	21
7	Typical Test Setup for Three Vibration Axes	22
8	Elevation Strobe Horizontal Circuit	24

Table

1	Parts Furnished by ARINC Research.	12
2	Equipment Furnished by ARINC Research	13
3	List of Modified Drawings of APQ-109 Assemblies	14

1
INTRODUCTION

1.1 BACKGROUND

During the latter half of 1970, ARINC Research Corporation conducted an availability analysis of the AN/APQ-109 Fire Control System of the F-4D aircraft. The work, performed under Contract F09603-70-A-2026-QP02 with the Ogden Air Materiel Area, was primarily directed toward determining the product improvement potential inherent in the FCS design. Specific problem areas in APQ-109 equipments were identified and recommendations were offered for correcting them. Analysis of available data indicated that implementation of the recommended product improvement program has the potential of increasing the operational availability and decreasing the maintenance manhours per flying hour for the APQ-109.

The aforementioned study revealed that most of the maintenance time and effort associated with the APQ-109 was expended in adjustment-type repairs rather than in the replacement of failed parts or line replaceable units (LRU's). * The majority of the electrical instability problems were found to be concentrated in three LRU's:

- a. Indicator Control Unit, WUC 74780;
- b. Synchronizer, WUC 74710; and
- c. Receiver/Transmitter, WUC 74790

*See ARINC Research publication C05-01-1-1103, Product Improvement Analysis of AN/APQ-120 Fire Control System, March 1971.

ARINC Research was then contracted (F09603-71-A-1437-QP01) to evaluate these three LRU's with the objective of recommending the needed redesign of their electrical adjustments and associated circuitry. As a result of that effort, modifications were recommended to 17 subassemblies in the three LRU's.* It was estimated that implementation of these modifications would reduce APQ-109 maintenance man-hours in the field by 11 percent.

1.2 SCOPE OF PRESENT STUDY

In the present study, conducted under Contract F42600-72-D-0779-0002, ARINC Research participated in an Air Force program to fabricate and conduct developmental testing of modified prototypes of the three LRU's. The Corporation's specific tasks were to:

1. Determine the parts required to modify the three LRU's, selecting "High Rel" parts where possible.
2. Procure for OOAMA certain of the needed components, either long-lead-time items or those not available from Government supply sources.
3. Assist OOAMA as required in fabricating one prototype electrical model of each of the three LRU's.
4. Participate in electrical testing of the prototype electrical models in an operational APQ-109 system at OOAMA. Make any design changes needed to make the models electrically compatible with the system.
5. Develop any new drawings required to incorporate the design changes recommended by ARINC Research.
6. Build mechanical prototypes of assemblies recommended for significant mechanical modification.
7. Plan and conduct vibration and shock tests of the individual mechanical prototype assemblies.

*See ARINC Research publication C12-01-1-1157, Analysis of Adjustments in Selected Line Replaceable Units of AN/APQ-109 FCS, February 1972.

C42-01-1-1178

8. Deliver to OOAMA the parts identified in Task 2.
9. Assist in the preparation of module and system test plans and procedures as applicable to the APQ-109 product improvement program.
10. Monitor OOAMA procedures and methods for assembly engineering prototypes and provide assistance as required.

2
SUMMARY

The previously recommended modifications for improving the stability and/or desensitizing individual adjustment points of the AN/APQ-109 Fire Control System fall into two categories:

- a. Replacement of existing components (resistors, potentiometers, etc.) with newer components exhibiting better stability characteristics.
- b. Modification of circuits to incorporate additional circuitry or components with changed values.

In cooperation with OOAMA, ARINC Research made the necessary modifications per item b above and subjected the modified assemblies to developmental testing. Results of testing of these assemblies are summarized on the following page. In all instances the test deflection (in inches or degrees) exceeded the minimum expected control range for the adjustment points. The "expected" values were those calculated by ARINC Research in the previous study, and represented the range of satisfactory performance.

In theory, an adjustment parameter would be 100-percent desensitized if the test-recorded deflection equaled the expected value. When the test result exceeds that value, some amount of undesirable sensitivity still exists. On the other hand, the test result should never be less than the expected value or the adjustment component would not be able to fully compensate for all the system variables.

SUMMARY OF APQ-109 CIRCUIT MODIFICATION TESTING

LRU	Assembly	Adjustment	Location	Expected Minimum Range ^{1/}	Test Result ^{2/}
ICU	A3701	Pilot A-Gun V Cent.	R8	1.6"	2.01"
	A3703	Range Rate Circle Amp	R12	1.6"	1.65"
	ICU Main Chassis	Dot Stbd Limit	R3732	0.46"	0.83"
	ICU Main Chassis	Range Rate Zero	R3706	34°	26° ^{3/}
	A3703	ASE Circle Amp	R18	0.21"	0.27"
	A3700	E1. Strobe Vert. Ampl.	R4	28°	29°
	A3723/24	Pilot B-Gun V Cent.	R14	3.2"	3.4"
	A3718	R.O. B-Gun V Cent.	R23	1.9"	2.7"
		R _A Adj	R15	0.65"	1.0"
		R _{MIN} Adj	R25		
Sync	A2904	Back Bias Adjust	R12	130V	133V
	A3002	Lock-On Sensitivity Adjust	R13	11V	14.2V
^{1/} Minimum expected control range on modified circuit as determined by calculation.					
^{2/} Control range measured on modified circuit using Hill AFB simulator.					
^{3/} Adequate control range was obtained when associated circuitry was properly modified to reflect latest production design; see Section 3.3 of this report.					

3
TASK RESULTS

3.1 TASK 1 - PARTS DETERMINATION

ARINC Research compiled an initial listing of parts needed for modification of the prototype assemblies and delivered it to OOAMA, which checked the list against items available from local federal stock. For needed parts not in stock, the stock was searched for possible substitutes. If no substitute could be found the part was procured by ARINC Research at OOAMA's request (see Section 3.2).

The initial parts list contained many "high reliability" parts, but since these were not available in federal stock at Hill Air Force Base, OOAMA decided to use standard military-qualified parts.

3.2 TASKS 2 AND 8 - PARTS AND EQUIPMENT PROCUREMENT AND DELIVERY

As previously stated, those parts not available in local federal stock at Hill AFB and for which no available substitution could be found were procured by ARINC Research and delivered to OOAMA. Table 1 is a listing of such parts.

In addition to the procurement of parts to be used in the fabrication of the prototype hardware, ARINC Research was requested by OOAMA to procure certain equipments not originally covered in the contract. This additional requirement necessitated a modification to the original contract involving a substantial increase in funding. The procured equipments are listed in Table 2.

3.3 TASKS 3 and 4 - ELECTRICAL PROTOTYPE ASSURANCE TESTS

To ascertain that those recommended modifications involving changes to the electrical configuration produced the desired results at the system level, tests were conducted in an operating system using assemblies modified in this manner. These tests were performed at Hill AFB by OOAMA personnel with the on-site assistance of ARINC Research personnel.

The prototype circuits were assembled using component parts of the recommended value but not necessarily of the type and mechanical configuration intended for the final prototype circuits, since stability and environmental testing were not involved at this point in the program. In the case of the signal AGC assembly, a potted module within the synchronizer, an unpotted assembly was purchased from Electronic Modules, Inc., and forwarded to Hill AFB for testing.

Tests performed on these assemblies generally consisted of:

- a. A check to determine that the adjustments of concern could be adjusted to the point required by published alignment procedures; and
- b. That the range of adjustment was within the limits determined to be necessary in previous ARINC Research analyses.

A problem was encountered at the outset of testing of the range rate zero adjustment and associated circuits. The first test indicated that the ICU could not be satisfactorily calibrated with respect to range rate zero. Subsequent attempts were made using different A3709 (P/N 501R333G03) assemblies, and it was found that satisfactory calibration could be accomplished with four out of six assemblies tested. Examination of these assemblies revealed that in those cases where a satisfactory calibration was possible, A3709-R18 had a value of 2 kilohms, while in the other two instances it had a value of 2.8 kilohms. All type A3709 assemblies were identified with the same part number, 501R333G01. The 2-kilohm value for A3709-R18 corresponds with the value in T.O. 12P2-APQ109-4, "Illustrated Parts Breakdown," dated 15 July 1970; and on drawing 664R066, revision J, for configuration G03. Therefore the modification recommended by ARINC Research is based on a configuration of A3709 with A3709-R18 having a value of 2 kilohms.

Another problem encountered during testing of the range rate zero adjustment was the failure to obtain the desired range of adjustment (26 degrees was measured versus the 34 degrees specified). The source of this problem was found to be in the range rate phase-shifting network (R3708, R3704, C3703, R3707, etc.), which produced a phase shifted range of 51 degrees versus the 90 degrees specified in T.O. 12P2-2APQ109-2-1, 15 July 1970. Since a portion of the required range was included to allow for adjustment compensation of a percentage change in the phase shifted range, acceptance of a 26-degree range of adjustment is considered feasible.

The test procedures and results are given in Appendix A.

3.4 TASK 5 - MECHANICAL REDESIGN

The mechanical redesign incorporating the recommended modifications to the 33 adjustments and associated circuits was performed and documented in the drawings listed in Table 3. The modifications affected 14 types of assemblies - eight in the ICU, three in the RT, and two in the synchronizer. The remaining three potted assemblies in the synchronizer were redesigned mechanically by Westinghouse.

The approach to the redesign was to develop modifications that would require a minimum of mechanical rework to the existing hardware, be suitable for the production of a limited number of prototype assemblies, and yield assemblies capable of withstanding the environmental conditions specified for the APQ-109.

3.5 TASKS 6 AND 7 - MECHANICAL PROTOTYPE FABRICATION AND TESTING

Upon completion of the mechanical redesign activities, each modified assembly was reviewed and a decision made as to whether the redesign warranted vibration testing to prove its mechanical integrity. The assemblies selected for vibration testing were those to which components had been added in a manner not consistent with the method of mechanical attachment employed in the original design. The assemblies selected for testing were:

<u>Part Number</u>	<u>Nomenclature</u>
501R327G02	A-Gun Deflection Amplifier
501R329G01	940-Hz Oscillator and Modulator
501R333G03	Range Rate and Elevation Strobe Demodulator
501R342G03	Acquisition Symbol Range and R-Min, R-A Generator
501R343G02	B-Gun Deflection Amplifier

Using assemblies provided as government-furnished equipment, ARINC Research modified one assembly of each of those listed above at its Santa Ana facility. Photographs of the modified assemblies are shown as Figures 1 through 5.

These assemblies were then tested per method 514.1 of MIL-STD-810B, Figure 514.1-2, curves AR and G (see Figure 6A and 6B of this report). Each sample

was subjected to successive 20-minute up-and-down sweeps per curve AR and Curve G. A typical test setup for each of the three vibration axes is pictured in Figure 7.

No modified portions of the assemblies experienced mechanical failure. However, certain of the original components on the test samples exhibited failures at the leads and solder joints. Since the APQ-109 does not have a history of mechanical failure of the original parts under the operational environment, it is concluded that the modified portions of the prototype assemblies have sufficient mechanical integrity.

Vibration testing was conducted by Ogden Technology Laboratory, Inc., of Fullerton, Calif. The Ogden test report is reproduced in Appendix B.

3.6 TASK 9 - TEST PLANS AND PROCEDURES

Since OOAMA was required to use the APQ-100 instead of the APQ-109 system for testing, ARINC Research was requested to determine any effects this substitution would have on the planned tests and procedures.

Schematic diagrams of both systems were studied with respect to the comparative characteristics of the circuits containing the proposed modifications. Identified differences were then evaluated to determine the effects they would have on the performance of the modified circuits. Where it was found necessary, alternate test procedures were proposed.

The circuits in which dissimilarities were found included the following:

- a. The elevation strobe vertical circuit in the ICU of the APQ-100 has two additional transistors in series with the signal path (Q3 and Q4 on A3710). These transistors would introduce a varying dc offset voltage not found in the APQ-109 configuration. The circuit can be essentially changed to the APQ-109 configuration by removing these transistors and replacing them with a jumper from the collector to the emitter connection points.
- b. The elevation strobe horizontal circuit in the ICU is significantly different for the two systems, as shown in Figure 8. As in the previous case, changes can be made to A3710 that will make its configuration very similar to that of the APQ-109.

- c. For the B-gun dc amplifier circuits on A3720 of the ICU, a constant voltage source is used to bias transistors Q2-A and -B in the APQ-100, while a constant current source is used for this bias in the APQ-109. The A3720 configuration on the APQ-100 can be converted to the APQ-109 configuration by 1) removing diodes CR3 and CR4, and 2) changing the value of R27, R28, R29, and R30 from 12.4 to 10 kilohms.
- d. A slight difference exists in the lock-on sensitivity circuit in the synchronizer, but not of an extent that would affect the test results.

To compensate for the first three of the above-noted circuit differences, changes will be necessary to both the "unmodified" and "modified" ICU's used in the OOAMA test program. The "unmodified" ICU's should be changed to reflect an APQ-109 configuration. The "modified" ICU's should incorporate, in addition to the APQ-109 changes, the changes recommended by ARINC Research for improvement of the APQ-109.

The above changes have been incorporated in the drawing documenting the mechanical redesign.

3.7 TASK 10 - PROTOTYPE FABRICATION SUPPORT

In support of OOAMA's prototype fabrication effort at Hill AFB, ARINC Research constructed and delivered the following prototype subassemblies:

<u>Nomenclature</u>	<u>Part No.</u>	<u>Qty</u>
Terminal Board	XC42-01-54	6
Terminal Board	XC42-01-32	20
Insulator	XC42-01-33	30

Assistance was also provided by ARINC Research during this effort in the form of on-site and telephone consultation concerning problems arising during fabrication. Upon resolution of the problems, appropriate changes were made to the drawings.

TABLE 1. PARTS FURNISHED BY ARINC RESEARCH

Part Number	Nomenclature	Qty	Date Delivered
USECO 1310C	Terminal	100	12 May 72
USECO 2000B	Terminal	200	12 May 72
USECO 1310	Terminal Die	1 Set	31 May 72
USECO 2000	Terminal Die	1 Set	31 May 72
MS20426002-4	Rivet	75	31 May 72
RN55C1693F	Resistor	50	12 May 72
RN55C7501F	Resistor	50	12 May 72
APW-1/2-104-6	Potentiometer	50	12 May 72
APW-1/2-104-10	Potentiometer	20	12 May 72
APW-1/2-104-4	Potentiometer	20	12 May 72
RN65C-5113F	Resistor	50	12 Jun 72
RN65C1004F	Resistor	50	12 Jun 72
RN70D1243F	Resistor	50	12 Jun 72
XC42-01-33	Terminal Board	20	31 May 72
XC42-01-32	Insulator Board	20	31 May 72
XC42-01-54	Terminal Board	6	5 Jun 72
604R392G01	Signal AGC Module	1	12 May 72

TABLE 2. EQUIPMENT FURNISHED BY ARINC RESEARCH

Mfr	Model	Nomenclature	Qty	Date Delivered
Hewlett-Packard	6286A	} Power Supply	2	21 Jun 72
	6291A		2	15 May 72
	6296A		2	15 May 72
	6448A		2	6 Jun 72
	895A		6	
	214A	Pulse Generator	1	15 May 72
	14525A	Mount	3	15 May 72
Tektronix	015-0189-00	High Voltage Transformer	1	30 May 72
	015-0190-00	Dc Bucking Coil	1	30 May 72
	015-0194-01	High Voltage Bushing	1	30 May 72
	010-0207-00	Dc Current Probe	1	30 May 72
Premier Metal Products	RMX-7719-24	Rack	3	15 May 72
	MAP-719	} Panel	4	15 May 72
	MAP-1419		2	15 May 72
	MAP-3519		1	15 May 72

TABLE 3. LIST OF MODIFIED DRAWINGS OF APQ-109 ASSEMBLIES

Affected Assembly	LRU	Drawing Number
A3701/A3707	ICU	XC42-01-14 XC42-01-15
A3702/A3708	ICU	XC42-01-30
A3703	ICU	XC42-01-21 XC42-01-22
A3709	ICU	XC42-01-25 XC42-01-26
A3715	ICU	XC42-01-28
A3718	ICU	XC42-01-12 XC42-01-13
A3720	ICU	XC42-01-29
A3723/A3724	ICU	XC42-01-31 XC42-01-32 XC42-01-33 XC42-01-34
Main Chasis and TB3701	ICU	XC42-01-51 XC42-01-52 XC42-01-53 XC42-01-54 XC42-01-55
A3001	Sync	XC42-01-18
A3002	Sync	XC42-01-47
R420	RT	XC42-01-39
R790	RT	XC42-01-36
R1412	RT	XC42-01-38

C42-01-1-1178

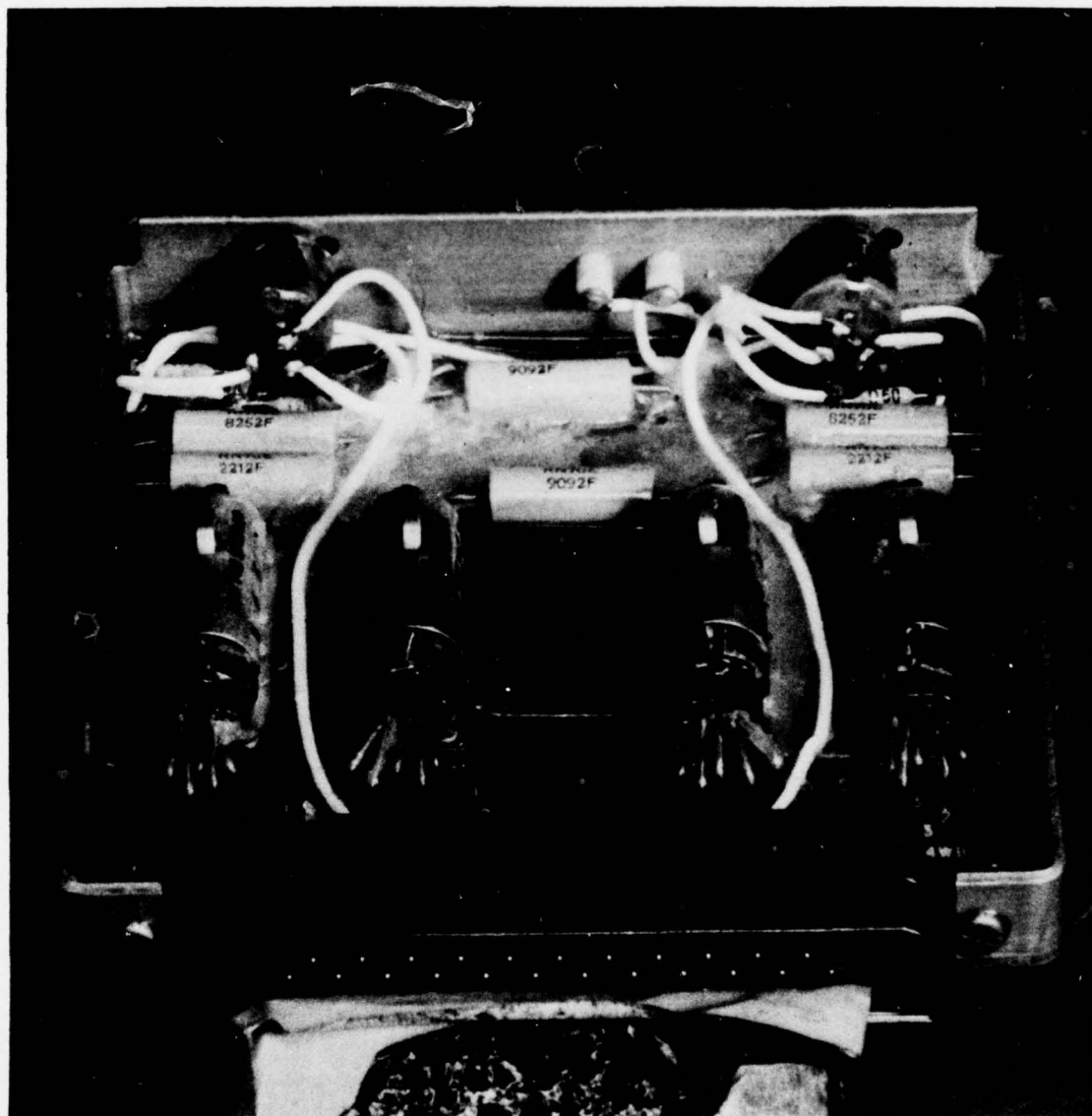

Figure 1. Modified A-Gun Deflection Amplifier,
P/N 501R327G02

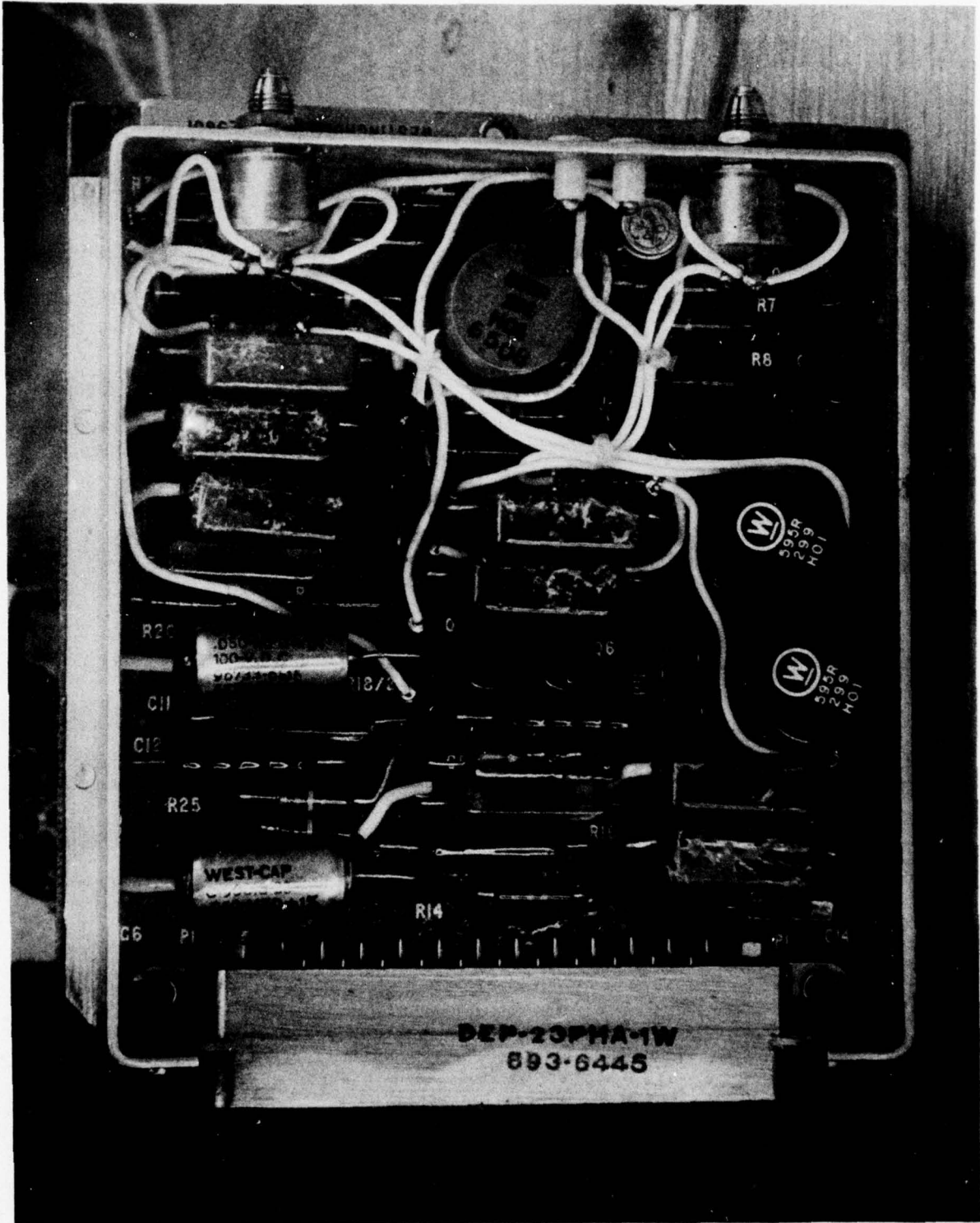

Figure 2. Modified 940-Hz Oscillator and Modulator,
P/N 501R329G01

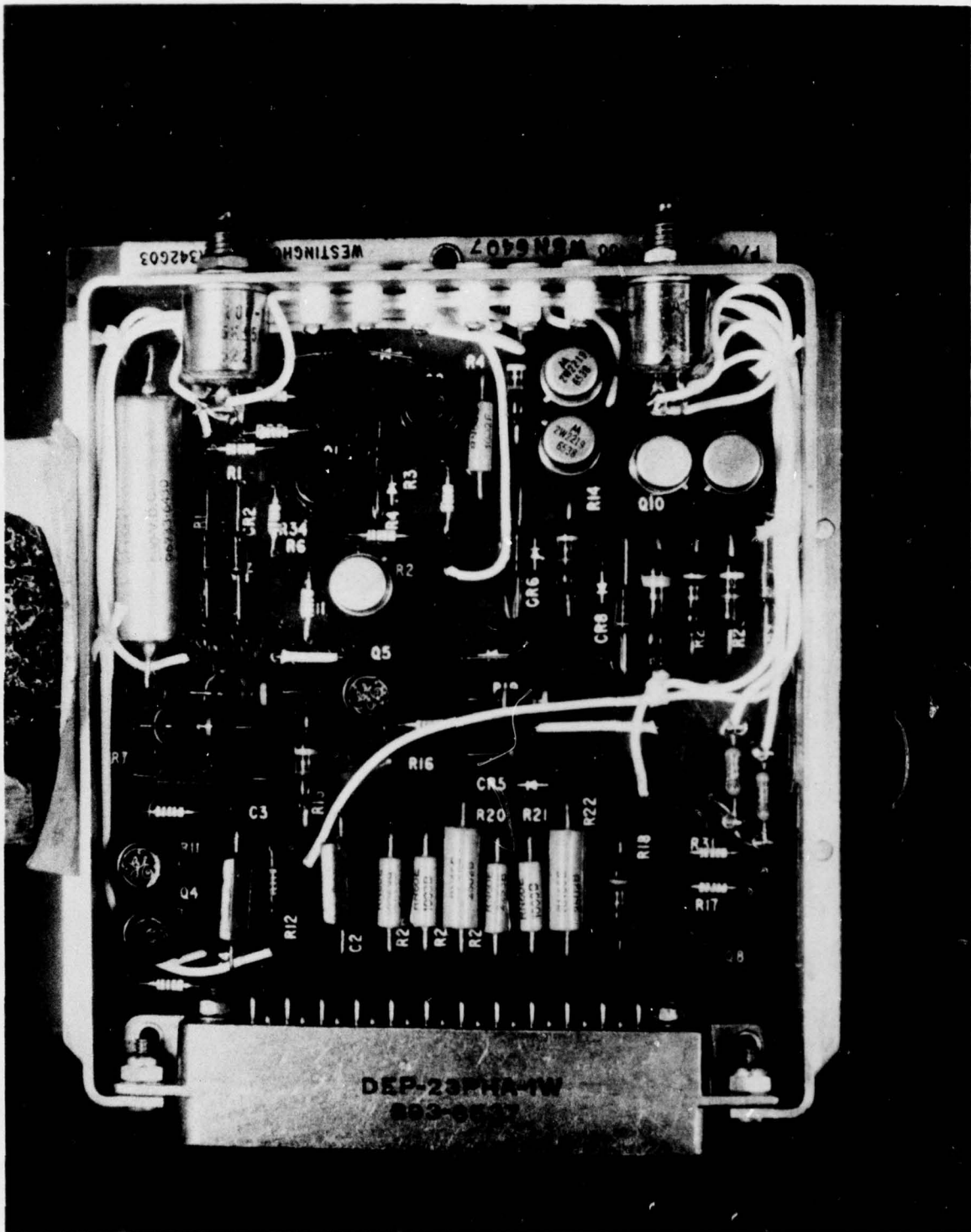

Figure 4. Modified Acquisition Symbol Range and R-Min, R-A Generator, P/N 501R342G03

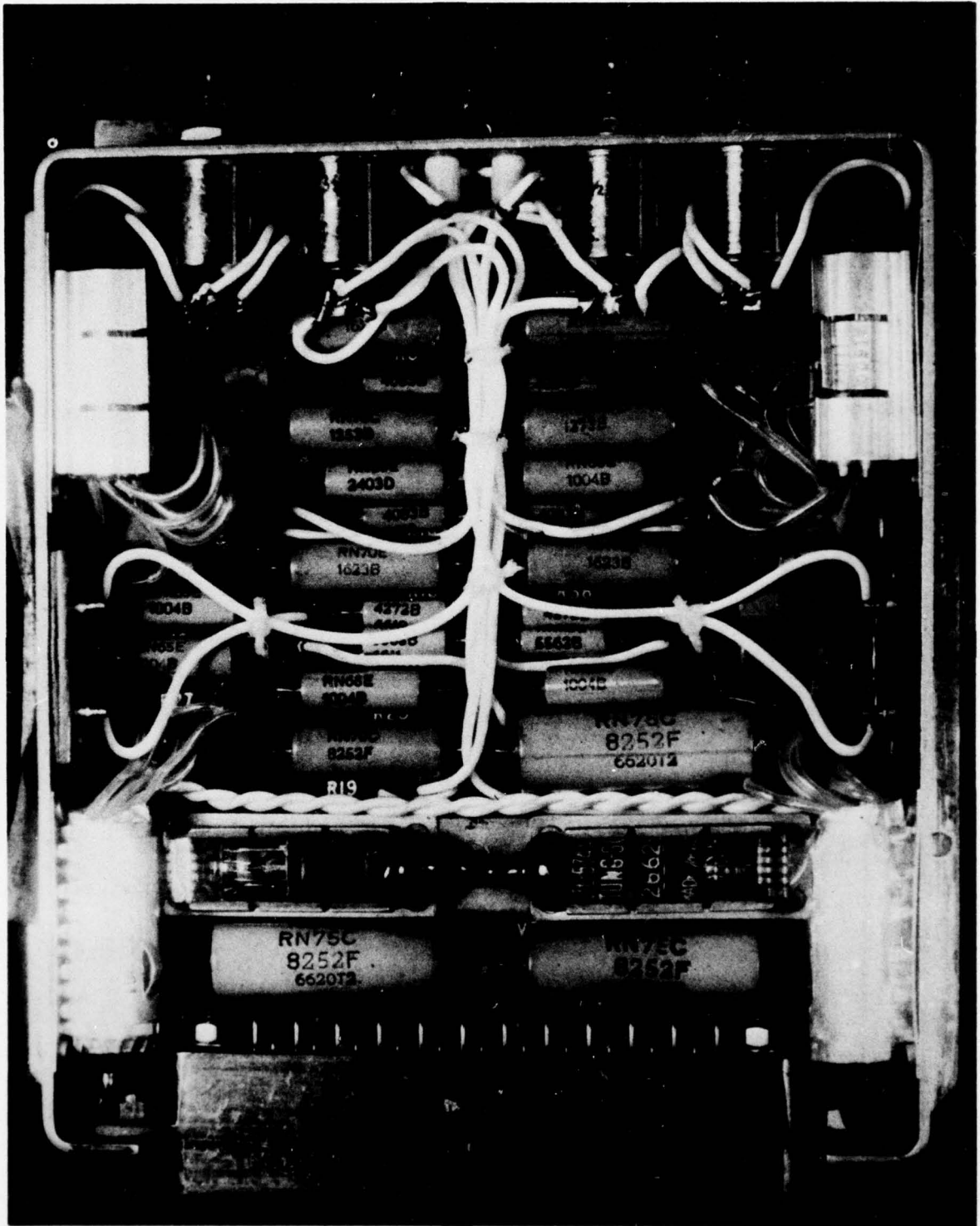

Figure 5. Modified B-Gun Deflection Amplifier,
P/N 501R343G02

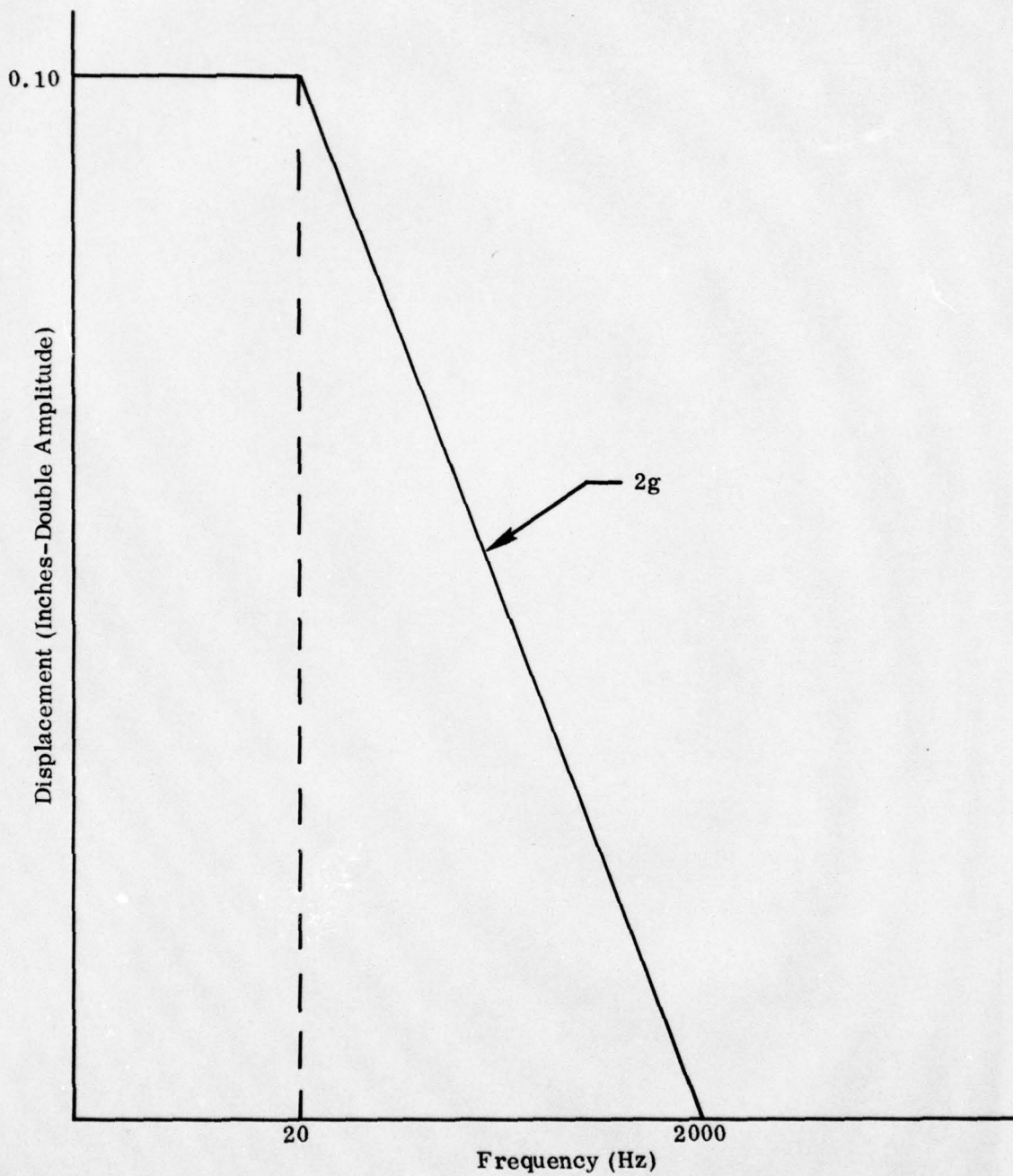

Figure 6A. Vibration Curve AR (Used for Initial Sweep)

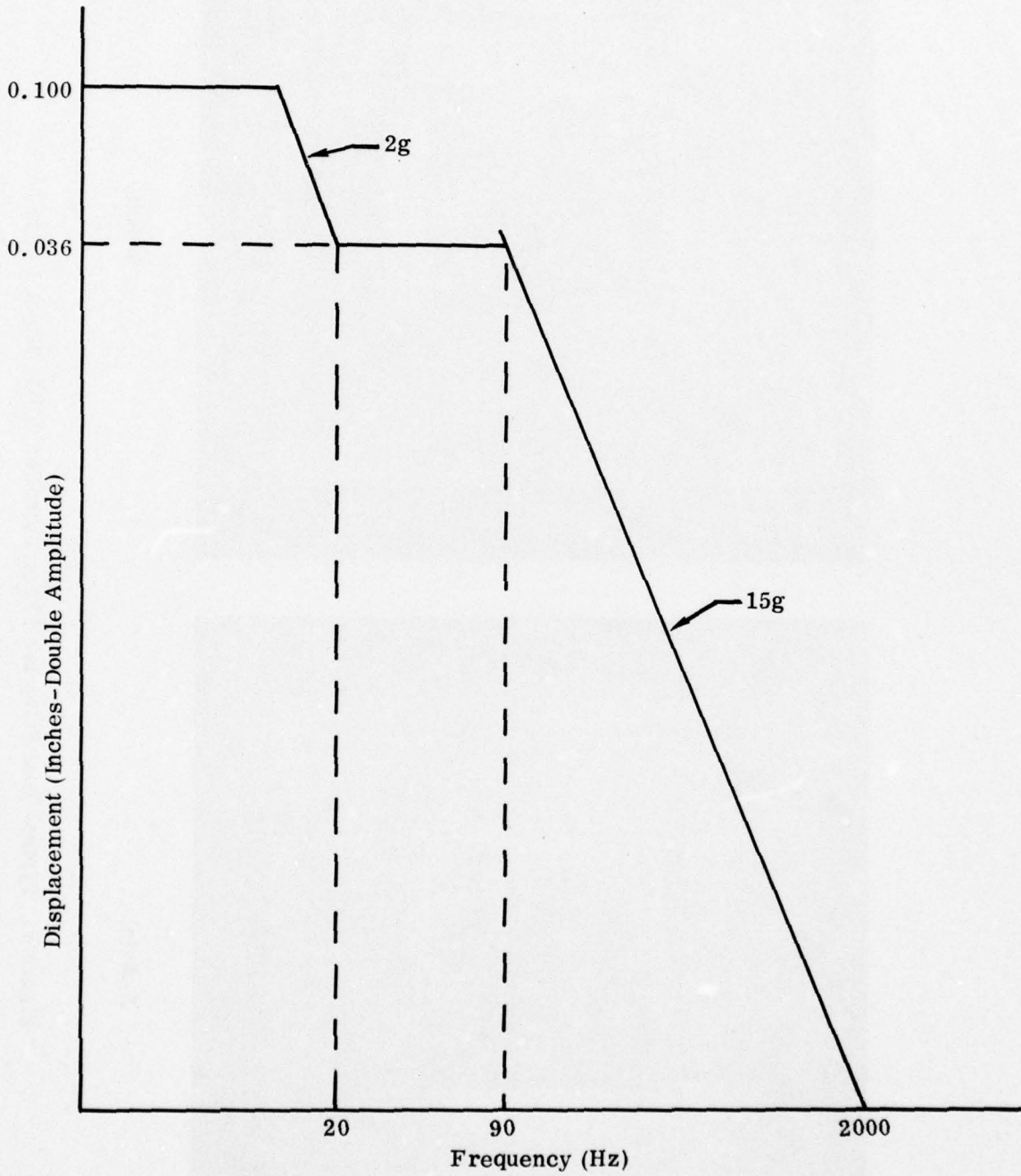
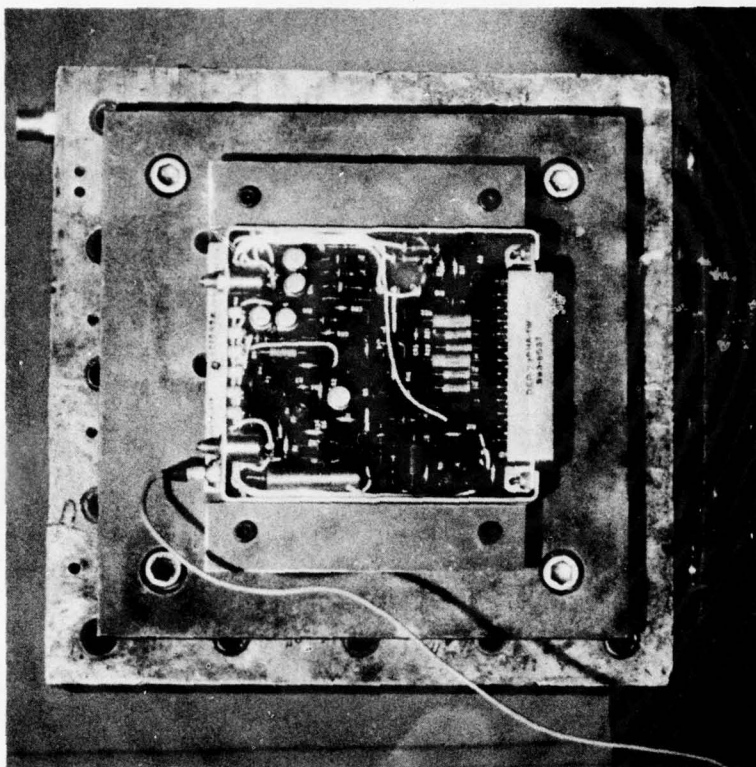
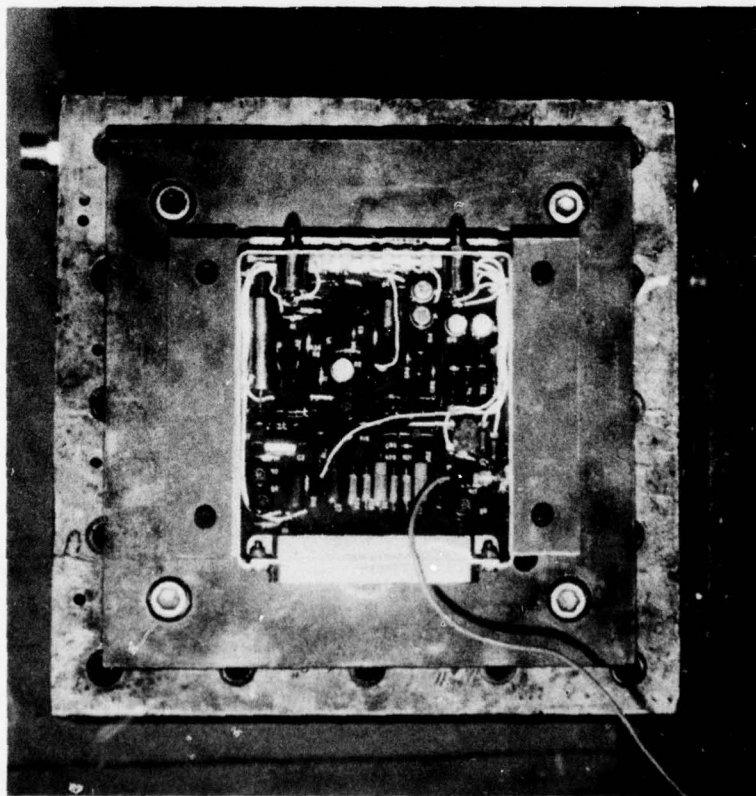

Figure 6B. Vibration Curve G (Used for Final Sweep)



Y-Axis



X-Axis

Figure 7. Typical Test Setup for Three Vibration Axes (Sheet 1 of 2)

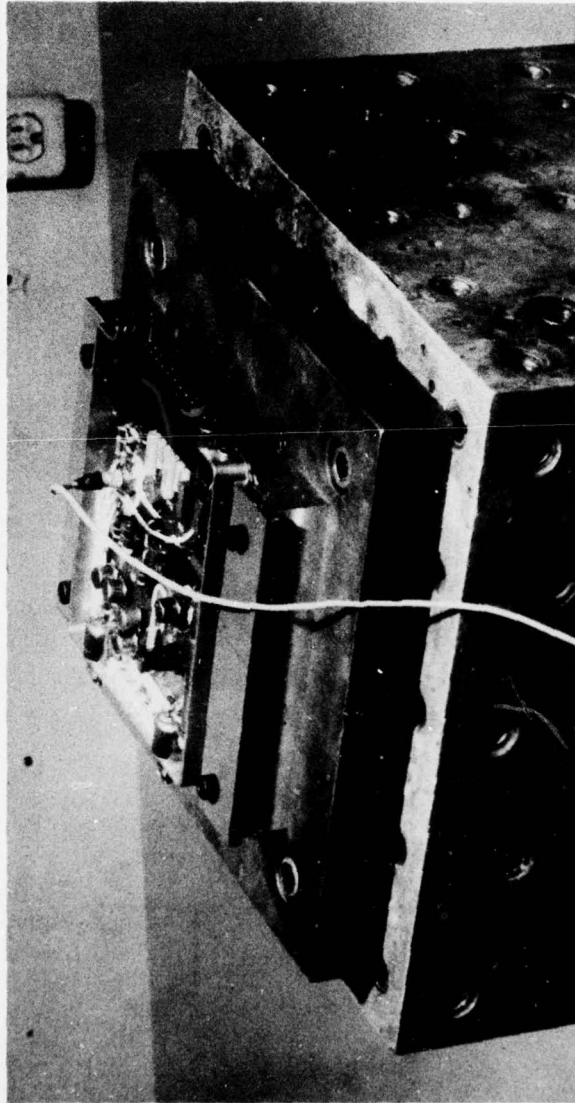

Z-Axis

Figure 7. (Sheet 2 of 2)

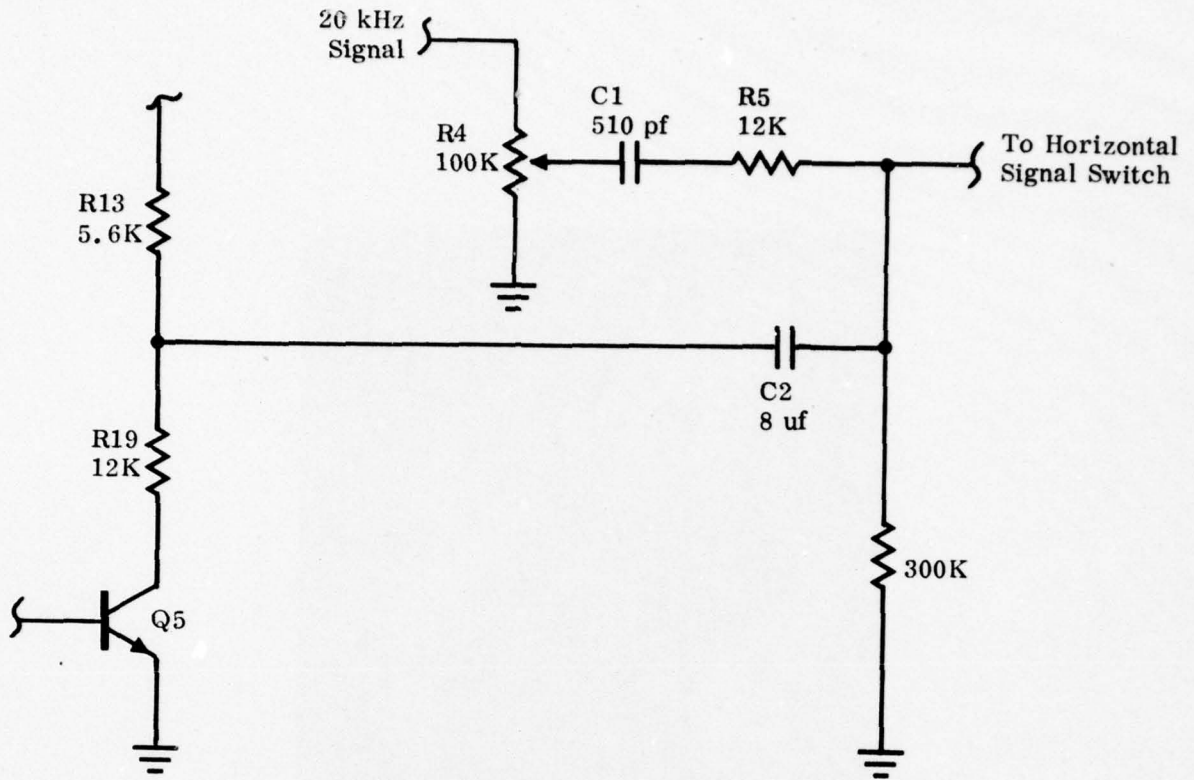

A. Configuration in APQ-100
(All components located on A3710.)

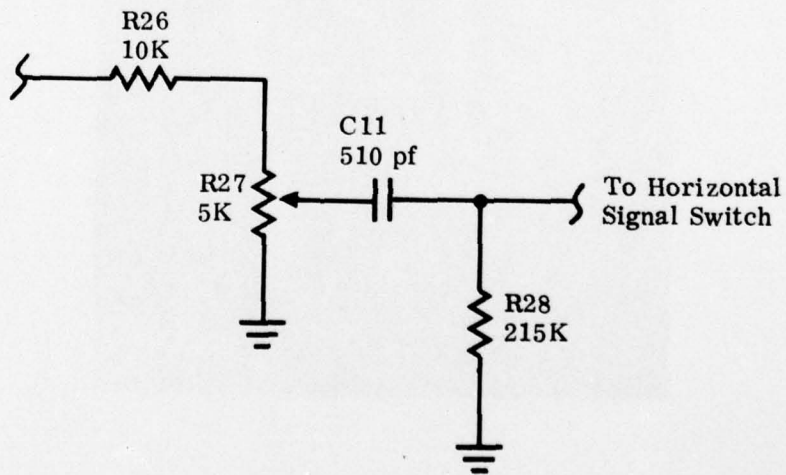

B. Configuration in APQ-109
(All components located on A3715.)

Figure 8. Elevation Strobe Horizontal Circuit

C42-01-1-1178

APPENDIX A
PROCEDURES AND RESULTS,
ELECTRICAL PROTOTYPE TESTING

Assembly: A-Gun Deflection Amplifier

Ref. Sketch: XC42-01-1

Test Procedure:

- Step 1. Set controls as follows:
- a. Radar power - test
 - b. Track - manual
 - c. Test - Dot bal (hold)
2. Check that the aimdot is centered. If not, realign ICU.
3. Adjust R8 fully CW, measure and record the aimdot deflection from center.
4. Adjust R8 fully CCW, measure and record the aimdot deflection from center.
5. The sum of the deflections in 3 and 4 above shall be greater than 1.6 inches.

Test Results:

- Step 3. 1.2 inches
4. 0.9 inches
5. 2.1 inches

Assembly: Range Rate Circle Generator

Ref. Sketch: XC42-01-3

Test Procedure:

Step 1. Set controls as follows:

- a. Radar power - test
- b. Track - manual
- c. Test - 0

2. Adjust R12 for a range rate circle diameter of 3.25 ± 0.06 inches.

3. Set R12 fully CCW. Measure and record the diameter of the range rate circle.

4. Set test to 3 and repeat step 3 above.

5. Set R12 fully CW. Measure and record the diameter of the range rate circle.

6. The difference between the diameters measure in steps 4 and 5 above shall be greater than 1.6 inches.

Test Results:

Step 3. 2.13 inches

4. 1.25 inches

5. 2.90 inches

6. 1.65 inches

Assembly: Dot Limit Adjust

Ref. Sketch: XC42-01-4

Test Procedure:

- Step 1. Set controls as follows:
- a. Radar power - test
 - b. Track - manual
 - c. Test - 0
 - d. Power (missile control panel) - radar standby
 - e. Select - heat
2. Action: Full action and release
 3. Turn hydraulic power on.
 4. Move radar control stick full right and adjust R3732 to position aimdot 1.4 inches to right of center.
 5. Set R3732 fully CW, measure and record the deflection of the aimdot from center.
 6. Set R3732 fully CCW, measure and record the deflection of the aimdot from center.
 7. The difference of the deflections measured in 5 and 6 above shall be greater than 0.46 inches.

Test Results:

- Step 5. 1.22 inches
6. 2.05 inches
7. 0.83 inches

Assembly: Range Rate Zero Adjustment

Ref. Sketch: XC42-01-5

Test Procedure:

- Step 1. Set controls as follows:
- a. Radar power - test
 - b. Test - dot bal (hold)
 - c. Track - auto
2. Adjust R3706 until CCW of V_C gap is positioned at 12 o'clock.
 3. Set R3706 fully CCW.
 4. Measure and record the angular displacement of the CCW edge of V_C gap from 12 o'clock.
 5. Set R3706 fully CW.
 6. Repeat step 4 above.
 7. The sum of the angle measured in steps 4 and 6 above shall be greater than 34 degrees.

Test Results:

- Step 4. +3 degrees
6. -23 degrees
 7. 26 degrees

Assembly: ASC Circle Generator

Ref. Sketch: XC42-01-6

Test Procedure:

- Step 1. Set controls as follows:
 - a. Radar power - test
 - b. Track - manual
 - c. Test - 3
2. Adjust R18 for an ASE circle diameter of 0.56 ± 0.06 inches.
3. Set R18 fully CW.
4. Measure and record the ASE circle diameter.
5. Set R18 fully CCW.
6. Repeat step 4 above.
7. The difference between the values measured in steps 4 and 6 above shall be greater than 0.21 inch.

Test Results:

- Step 3. 0.72 inch
6. 0.45 inch
7. 0.27 inch

Assembly: Elevation Strobe Amplitude Control Circuit

Ref. Sketch: XC42-01-8

Test Procedure:

- Step 1. Set controls as follows:
 - a. Radar power - test
 - b. Test - 2
 - c. Mode - BST
2. Adjust R4 until the elevation strobe indicates 38 ± 2 degrees.
3. Set R4 fully CW.
4. Record the elevation strobe indication.
5. Set R4 fully CCW.
6. Repeat step 4 above.
7. The difference between the indications recorded in steps 4 and 6 above shall be greater than 28 degrees.

Test Results:

- Step 4. 54 degrees
6. 25 degrees
7. 29 degrees

Assembly: Pilot or Pilot Sys Operator B-Gun Deflection Amplifier

Ref. Sketch: XC42-01-16

Test Procedure:

- Step 1. Set controls as follows:
 - a. Radar power - stby
 - b. Range - AI(50)
 - c. Mode - map PPI
2. Adjust R14 so that apex of the PPI display is at bottom of unmasked area on indicator.
3. Adjust R23 so that apex of the PPI display is at zero azimuth scribe on both indicators.
4. Set mode to PPI.
5. Set R14 fully CW.
6. Measure and record distance of sweep apex to the lower edge of the mask.
7. Set R14 fully CCW.
8. Measure and record distance of sweep apex to the lower edge of the mask.
9. Repeat steps 5, 6, 7, and 8 with R23.
10. The difference between the values measured in steps 6 and 8 should be 3.2 inches (difference using both R14 and R23 should be calculated).

Test Results:

- Step 6. 1.70 inches above
8. *Estimated 1.6 inches below
- 9./6. 1.8 inches above
- 9./8. *Estimated 1.6 inches below
10. 3.3 inches
- 10./9. 3.4 inches

*During this measurement the apex was off the scope. The estimate was made on the basis of potentiometer travel.

Assembly: ACQ Symbol Range and R Min, RA Generator

Ref. Sketch: XC42-01-17

Test Procedure:

- Step 1. Set controls as follows:
- a. Radar power - test
 - b. Test - Bit 3
 - c. Mode - map 13
 - d. Range - 25 Mi (lock-on any target)
2. Adjust R15 to position RA strobe on 15-mile range calibration mark.
 3. Adjust R25 to position R min strobe on 5-mile range calibration mark.
 4. Set R15 fully CW.
 5. Measure and record distance from 15-mile range calibration mark.
 6. Set R15 fully CCW.
 7. Measure and record distance from 15-mile range calibration mark.
 8. The difference between the values measured in steps 5 and 7 should be a minimum of 1.9 in.
 9. Set R25 fully CW.
 10. Measure and record distance from 5-mile range calibration mark.
 11. Set R25 fully CCW.
 12. Measure and record distance from 5-mile range calibration mark.
 13. The difference between the values measured in steps 10 and 12 should be a minimum of 0.65 inch.

Test Results:

- Step 5. 1.6 inches
7. 4.3 inches
8. 2.7 inches
10. 0.5 inch
12. 1.5 inches
13. 1.0 inch

Assembly: Back Bias Adjust

Ref. Sketch: XC42-01-45

Test Procedure:

Step 1. Set radar controls as follows:

- a. Power - test
 - b. Test - 0
 - c. Clutter - heavy
 - d. Mode - map-B
 - e. Range - AI(25-50)
 - f. Track - auto
 - g. Rcvr gain - max CW
2. Connect DC VTVM to A2904/TP2 on signal AGC Unit.
 3. Adjust A2904/R12 for a meter reading of 150 ± 0.5 Vdc.
 4. Check the mechanical setting of A2904/R12. Potentiometer should be approximately half way between its full CW and its full CCW position.
 5. Adjust A2904/R12 fully CW.
 6. Measure and record reading.
 7. Adjust A2904/R12 fully CCW.
 8. Measure and record reading.
 9. The difference in the values measured in steps 6 and 8 should be a minimum of 130 Vdc.

Test Results:

- Step 5. 182V
7. 49V
9. 133V

Assembly: Lock-On Relay Driver

Ref. Sketch: XC42-01-46

Test Procedure:

- Step 1. Set radar controls as follows:
 - a. Power - test
 - b. Test - 0
 - c. Clutter - heavy
 - d. Mode - map-B
 - e. Range - AI(25-50)
 - f. Track - auto
 - g. Revr gain - max CW
2. Connect dc VTVM to A2904/TP2 on Signal AGC Unit.
3. VTVM should read $150 \pm 0.5V$. If necessary adjust A2904/R12 to obtain this reading.
4. Connect dc VTVM to A3002/TP2.
5. Adjust A3002/R13 for a VTVM of $12 \pm 1V$.
6. Turn A3002/R13 fully CW.
7. Measure and record output voltage.
8. Turn A3002/R13 fully CCW.
9. Measure and record output voltage
10. The difference in the voltages measured in steps 7 and 9 should be a minimum of 11V.
11. Repeat step 5 above.

Test Results:

- Step 6. 1.8V
8. 16.0V
10. 14.2V

C42-01-1-1178

APPENDIX B
RESULTS OF VIBRATION
TESTING, MECHANICAL
PROTOTYPES

(The subject tests were conducted by Ogden Technology Laboratories, Inc., Fullerton, Calif., under contract with ARINC Research Corporation.)



OGDEN TECHNOLOGY LABORATORIES, INC.

Subsidiary of Ogden Corporation

1536 E. VALENCIA DRIVE, FULLERTON, CALIFORNIA 92631

TELEPHONE: 714/879-6110

15 May 1972

FULLERTON DIVISION REPORT NUMBER F-72255
Arinc Research Corp., P. O. No. Y 6973

- A. TEST: Sinusoidal Vibration
- B. TEST ITEMS: Printed Circuit Boards, Model APQ-109 (Modified)

P/N 501R333G03,	S/N FN6313
P/N 501R327G02,	S/N FN6668
P/N 501R343G02,	S/N WSN7471
P/N 501R342G03,	S/N WSN6407
P/N 501R329G01,	S/N 6617
- C. SPECIFICATIONS: Arinc Research Corp. Evaluation Test Procedure, dated 3 May 1972, and MIL-STD-810B, Method, 514.1, Curves AR & G.

D. RESULTS: This is to certify that the test items were subjected to the Sinusoidal Vibration Test according to the above specifications.

A Resonant Survey was conducted on each board in each axis using curve AR and a 20 minute sweep was then conducted in each axis using curve G. Results are recorded on the data sheets and X-Y Plots.

OGDEN TECHNOLOGY LABORATORIES, INC.



 R. D. Short, Division Manager

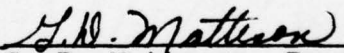

 G. D. Matteson, Project Engr.

Subscribed and sworn to before me this 17th day of May 1972.

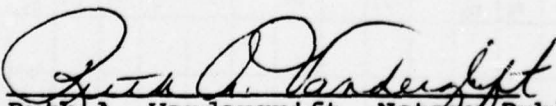

 Ruth A. Vandergrift, Notary Public in and for the County of Los Angeles, State of California. My commission expires Feb. 3, 1973.



 R. J. McKelligott
 Quality Assurance Manager



ENCL: Photographs

DATE STARTED:		PARTS TEST DATA ----- OGDEN TECHNOLOGY LABORATORIES, INC. (FULLERTON)										TEST ENGINEER:							
11 MAY 72		SPECIMEN DESCRIPTION: VIBRATION, SINE										OTL G.A.							
DATE COMPLETED:		TEST: J/N F-72255										GOV'T INSP.							
11 MAY 72		Circuit Board Assy for 501R326-03																	
TEMP. AMG.		VENDOR: ARINC RESEARCH Corp																	
HUMIDITY AMG.		CUST. INSP.																	
DATE	TIME	TA		VIBRATION FREQUENCY		DISPLACEMENT (D.A.)		INPUT ACCELERATION		SPECIMEN RESONANCE		OUTPUT ACCELERATION		AXIS		ELAPSED TIME		COMMENT	
		CPS	INCH	G-PK	CPS	NOTED	G-PK	X-Y-Z	NOTED	NOTED	NOTED	NOTED	NOTED	NOTED	NOTED	NOTED	NOTED		
1972	----	----	----	----	----	----	----	----	----	----	----	----	----	----	----	----	----	----	
NO. DAY	HOUR	°F																	
5-11	0840	72		5-20	0.1	—													
				20-2000	—	2.0													
				2000-5	SAME	SAME													
	0910				SAME AS ABOVE														
	0940				SAME AS ABOVE														
	1026			5-20	0.1	—													
				20-33	—	2.0													
				33-90	0.036	—													
				90-2000	—	15.0													
				2000-5	SAME	SAME													
	1050				SAME AS ABOVE														
					SAME AS ABOVE														
Y	1115	Y			SAME AS ABOVE														TRANSISTOR CAME OFF DURING DOWN SWEEP

DATE STARTED:		PARTS TEST DATA ----- OGDEN TECHNOLOGY LABORATORIES, INC. (FULLERTON)										TEST ENGINEER:										
11 MAY 72		SPECIMEN DESCRIPTION:										OTL Q.A.										
DATE COMPLETED:		CIRCUIT BOARD ASSY No 5018343602																				
11 MAY 72		VIBRATION, SINE																				
TEMP.	HUMIDITY	VENDOR:		DISPLACEMENT (D.A.)		VIBRATION FREQUENCY		INPUT ACCELERATION		SPECIMEN RESONANCE		OUTPUT ACCELERATION		ITEM NUMBER		ELAPSED TIME		RUN NO.		COMMENT		
Ans.	Ans.	ARINC RESEARCH CORP		J/N F-72255		CUST. INSP.		GOV'T INSP.														
DATE	TIME	TA	TIME	TA	INCH	G-PK	CPS	NOTED	G-PK	X-Y-Z	NOTED	NOTED	NOTED	NOTED	NOTED	NOTED	NOTED	NOTED	NOTED	NOTED	NOTED	NOTED
NO. DAY	HOUR	°F	CPS	CPS	INCH	G-PK	CPS	NOTED	G-PK	X-Y-Z	NOTED	NOTED	NOTED	NOTED	NOTED	NOTED	NOTED	NOTED	NOTED	NOTED	NOTED	NOTED
5-11	1246	72	5-20	0.1	—	—	—			Y	WISN 7471	0	14									
			20-2000	—	2.0	—	—															
			2000-5	SAME	SAME	—	—															
	1311			SAME AS ABOVE	—	—	—			X												
	1337			SAME AS ABOVE	—	—	—			Z												
	1406		5-20	0.1	—	—	—			Y												
			20-33	—	2.0	—	—															
			33-90	0.036	—	—	—															
			90-2000	—	15.0	—	—															
			2000-5	SAME	SAME	—	—															
	1430			SAME AS ABOVE	—	—	—			X												
Y	1524	Y		SAME AS ABOVE	—	—	—			Z		Y										

DATE STARTED:		PARTS TEST DATA ----- OGDEN TECHNOLOGY LABORATORIES, INC. (FULLERTON)										TEST ENGINEER:
11 MAY 72		SPECIMEN DESCRIPTION: VIBRATION, SINE										OTL Q.A.
DATE COMPLETED:		TEST: J/N F-72255										GOV'T INSP.
12 MAY 72		PAINTED CIRCUIT BOARD 501R327602										
TEMP. HUMIDITY		VIBRATION FREQUENCY										
AMB. AMB.		DISPLACEMENT (D.A.)										
		INPUT ACCELERATION										
		OUTPUT ACCELERATION										
		AI RESONANCE										
		AXIS										
		ITEM NUMBER										
		ELAPSED TIME										
		RUN NO.										
		COMMENT										
DATE	TIME	TA	VIBRATION FREQUENCY	DISPLACEMENT (D.A.)	INPUT ACCELERATION	OUTPUT ACCELERATION	AI RESONANCE	AXIS	ITEM NUMBER	ELAPSED TIME	RUN NO.	COMMENT
19 72	----	----	----	----	NOTED	NOTED	3	NOTED	NOTED	NOTED		SPECIFIED
NO. DAY	HOUR	°F	CPS	INCH	G-PK	CPS	G-PK	X-Y-Z	----			UNITS
5-11	1550	72	5-20	0.1	—			Z	FN 6668	0	20	
			20-2000	—	2.0							
			2000-5	SAME	SAME				20 MIN			
Y	1614							X		20 MIN	21	
5-12	0830							Y		20 MIN	22	
								Y		0	23	
			5-20	0.1	—							
			20-33	—	2.0							
			33-90	0.036	—							
			90-2000	—	15.0							
			2000-5	SAME	SAME					20 MIN.		
								X		20 MIN.	24	
Y	0950							Z		20 MIN.	25	

DATE STARTED:		PARTS TEST DATA ----- OGDEN TECHNOLOGY LABORATORIES, INC. (FULLERTON)				TEST ENGINEER:										
12 MAY 72		SPECIMEN DESCRIPTION:				E. A. Boyd										
DATE COMPLETED:		TEST:				OTL Q.A.										
12 MAY 72		PRINTED CIRCUIT BOARD Assy P/N 5-1R333603				GOV'T INSP.										
TEMP. AMG.	HUMIDITY AMG.	VENDOR:		J/N F-72255		CUST. INSP.										
		ARINC RESEARCH CORP.														
DATE	TIME	TA		VIBRATION FREQUENCY		INPUT ACCELERATION		SPECIMEN RESONANCE		OUTPUT ACCELERATION		ITEM NUMBER	ELAPSED TIME	RUN NO.	COMMENT	
		DISPLACEMENT (D.A.)	TA	INCH	G-PK	CPS	G-PK	CPS	NOTED	NOTED	3					NOTED
1972	----	----	----													
MO. DAY	HOUR	°F	CPS	INCH	G-PK	CPS	G-PK	CPS	G-PK	X-Y-Z	----					
5-12	1028	72	5-20	0.1	—					Z			0	26		
			20-2000	—	2.0								20 MIN.			
			2000-5	SAME	SAME								20 MIN.			
	1055				SAME AS ABOVE					X			20 MIN.	27		
	1120				SAME AS ABOVE					Y			20 MIN.	28		
	1250				SAME AS ABOVE					Y			20 MIN.	29		
			5-20	0.1	—											
			20-88	—	2.0											
			88-90	0.036	—											
			90-2000	—	15.0											
			2000-5	SAME	SAME											
	1320				SAME AS ABOVE					X			20 MIN.	30		
	1345				SAME AS ABOVE					Z			20 MIN.	31		

OGDEN TECHNOLOGY LABORATORIES, INC. (FULLERTON)
VIBRATION TEST DATA
ACCELERATION VS. FREQUENCY

DATE: 10 MAY 72	JOB NO.: F-72255	P.O. NO.: Y6973
SPECIMEN DESCRIPTION:	P/N:	S/N:
AXIS: Z	RUN NO.:	ACC. LOCATION: FIXTURE
CUSTOMER: ARINC RESEARCH CORP	ACC. NO.: 1 (CONTROL)	

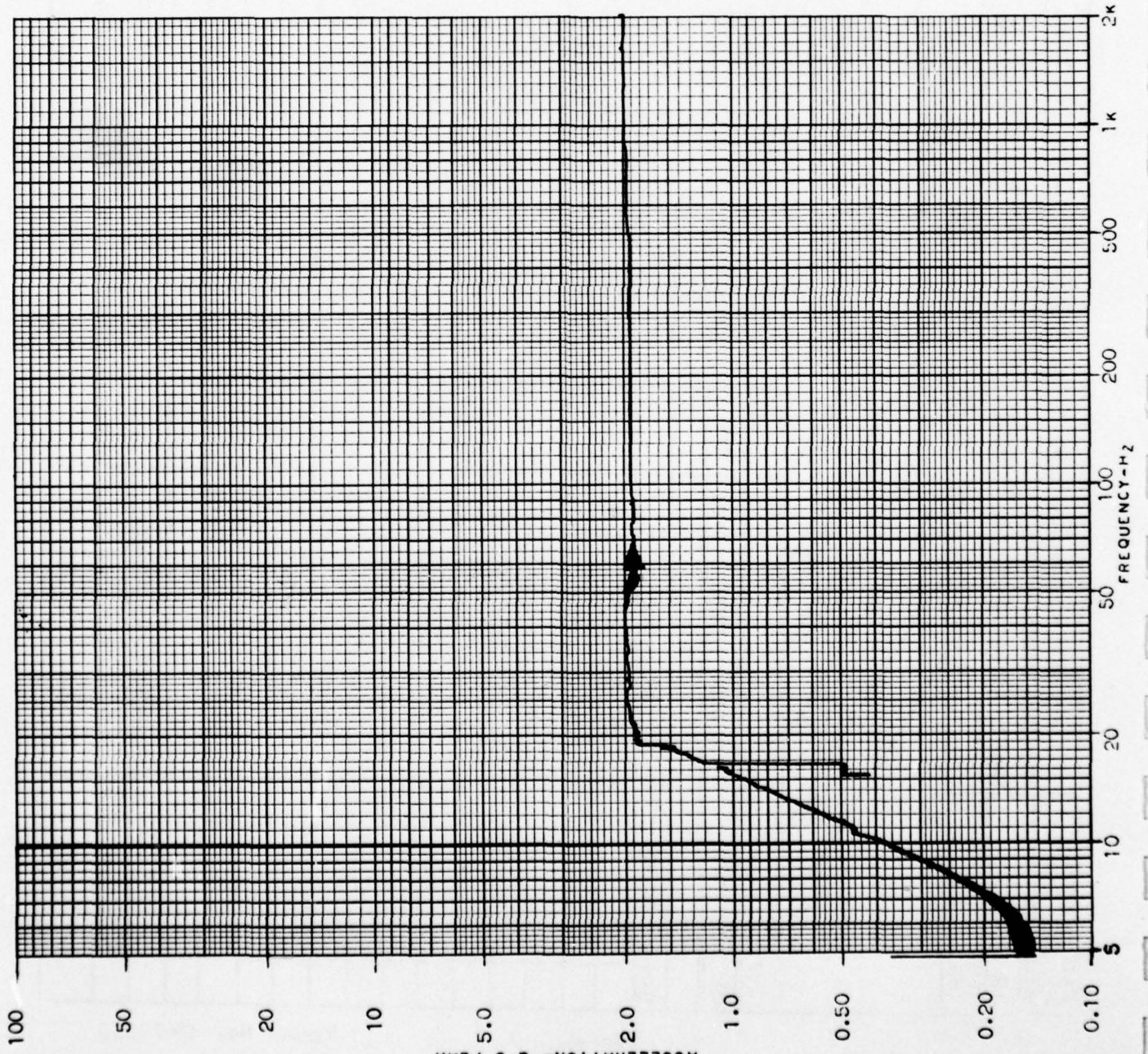

OGDEN TECHNOLOGY LABORATORIES, INC. (FULLERTON)

VIBRATION TEST DATA
ACCELERATION VS. FREQUENCY

DATE: 10 May 72	JOB NO.: F-72255	P.O. NO.: Y 6973
SPECIMEN DESCRIPTION:	P/N:	S/N:
AXIS: Z	RUN NO.: 1	ACC. LOCATION: FIXTURE
CUSTOMER: ARINC RESEARCH CORP.	ACC. NO.: 2 (RESPONSE)	

FIXTURE SURVEY

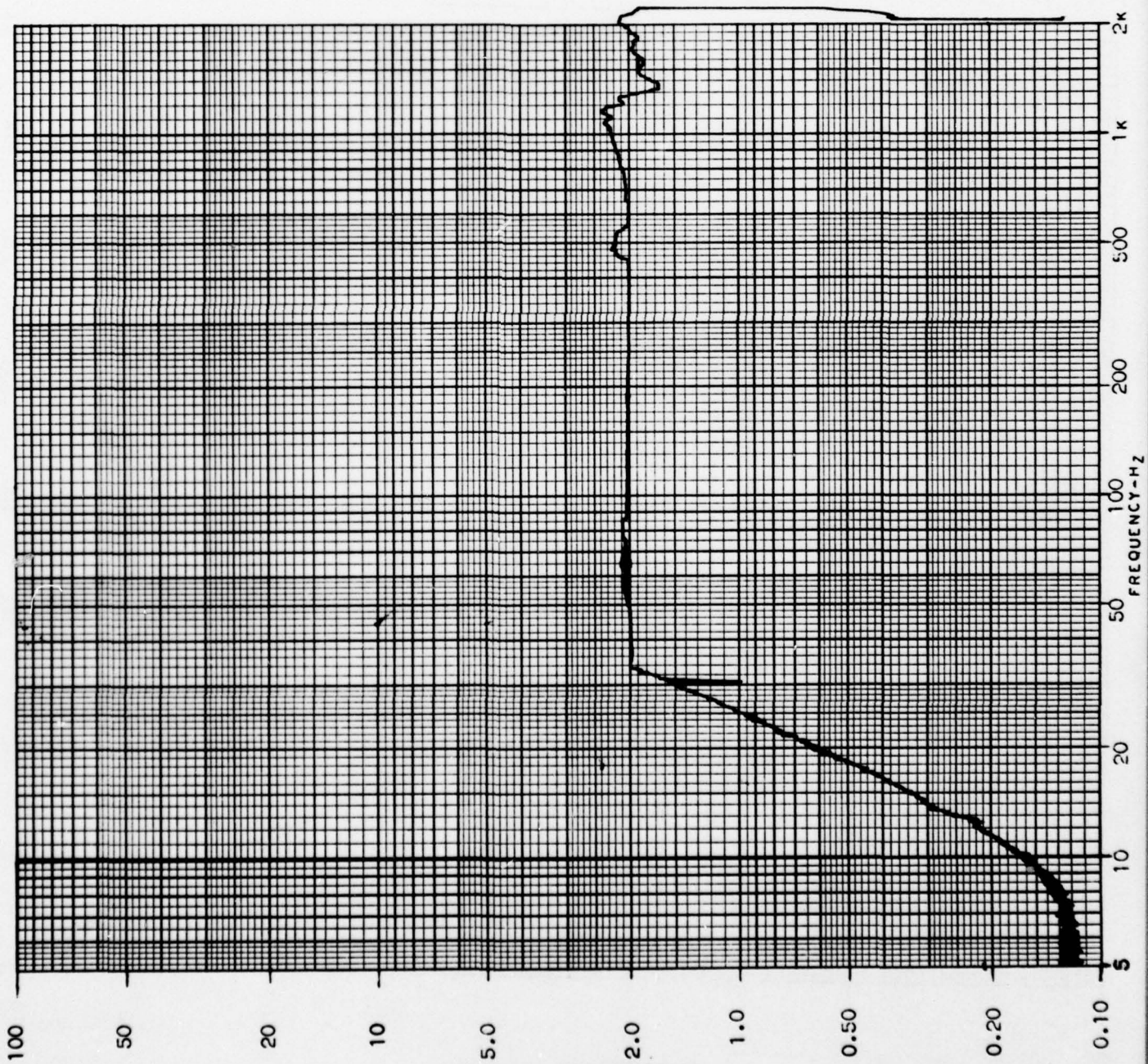

OGDEN TECHNOLOGY LABORATORIES, INC. (FULLERTON)

VIBRATION TEST DATA

ACCELERATION VS. FREQUENCY

DATE: 10 MAY 72	JOB NO.: F-72255	P.O. NO.: Y 6973
SPECIMEN DESCRIPTION: CIRCUIT BOARD ASSY	RUN NO.: 2	P/N: 501R329601 S/N: FN6617
AXIS: Y		ACC. LOCATION: SAMPLE
CUSTOMER: ARINC RESEARCH CORP.		ACC. NO.: 2 (RESPONSE)

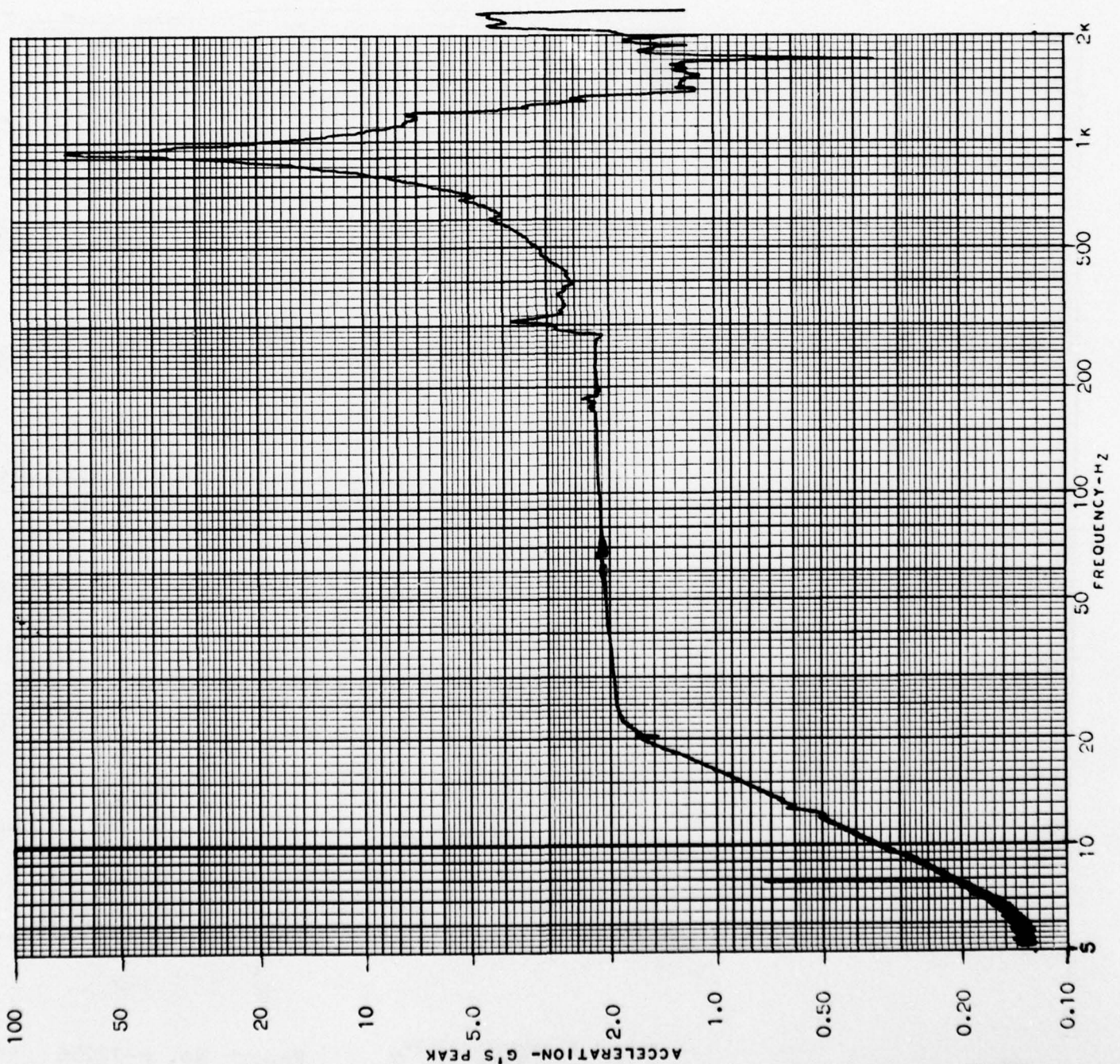

OGDEN TECHNOLOGY LABORATORIES, INC. (FULLERTON)
VIBRATION TEST DATA
ACCELERATION VS. FREQUENCY

DATE: 10 MAY 72 JOB NO.: F-72255 P.O. NO.: Y 6973
SPECIMEN DESCRIPTION: CIRCUIT BOARD ASSY P/N: 501R329G01 S/N: FN 6617
AXIS: X RUN NO.: 3 ACC. LOCATION: SAMPLE
CUSTOMER: ARINC RESEARCH CORP. ACC. NO.: 2 (RESPONSE)

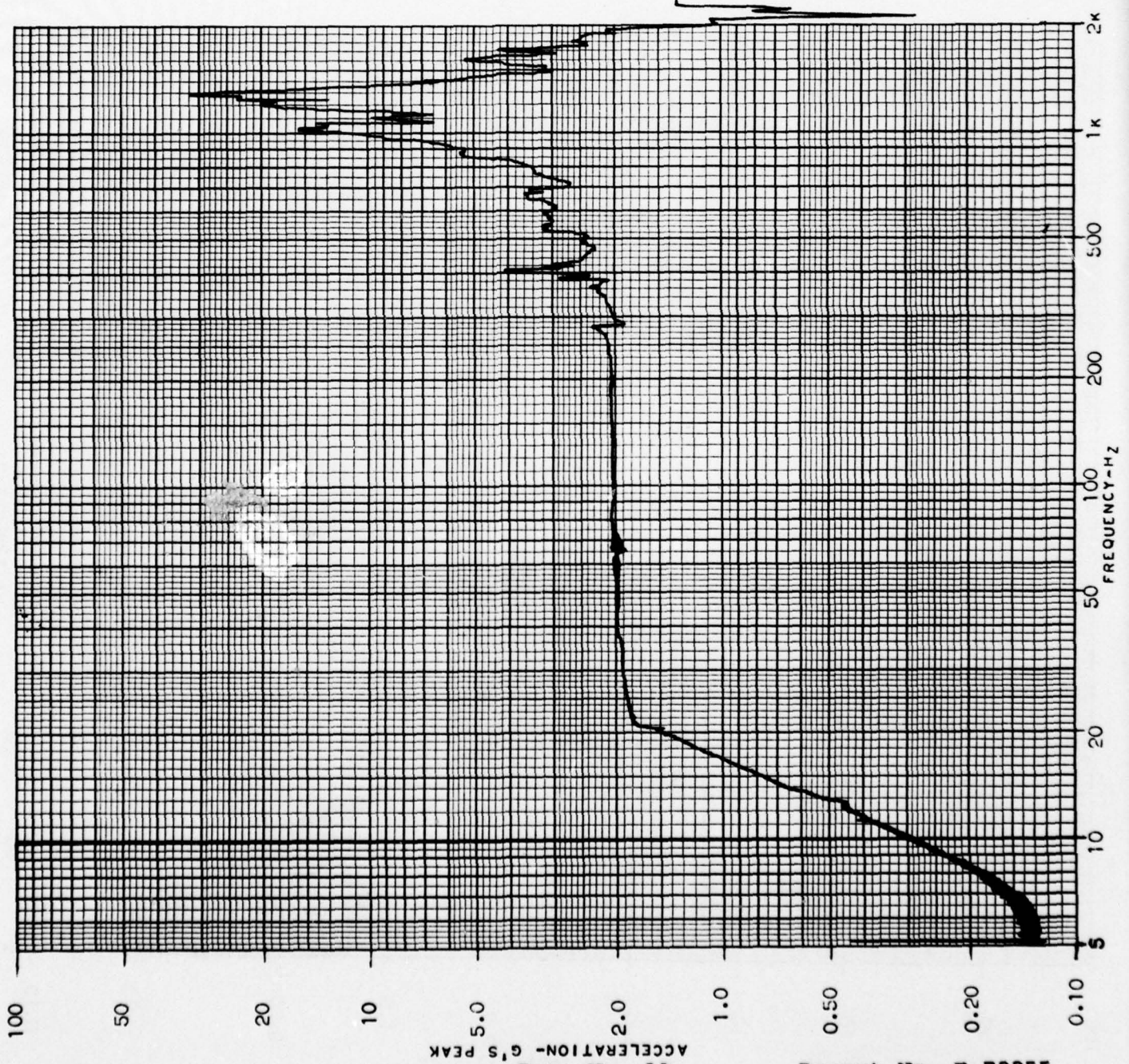

OGDEN TECHNOLOGY LABORATORIES, INC. (FULLERTON)

VIBRATION TEST DATA

ACCELERATION VS. FREQUENCY

DATE: 10 MAY 72 JOB NO.: F-72255 P.O. NO.: Y6973
SPECIMEN DESCRIPTION: PRINTED CIRCUIT BOARD ASSY P/N: 501R329601 S/N: 6617
AXIS: Z RUN NO.: 4 ACC. LOCATION: SAMPLE
CUSTOMER: ARINC RESEARCH CORP. ACC. NO.: 2 (RESPONSE)

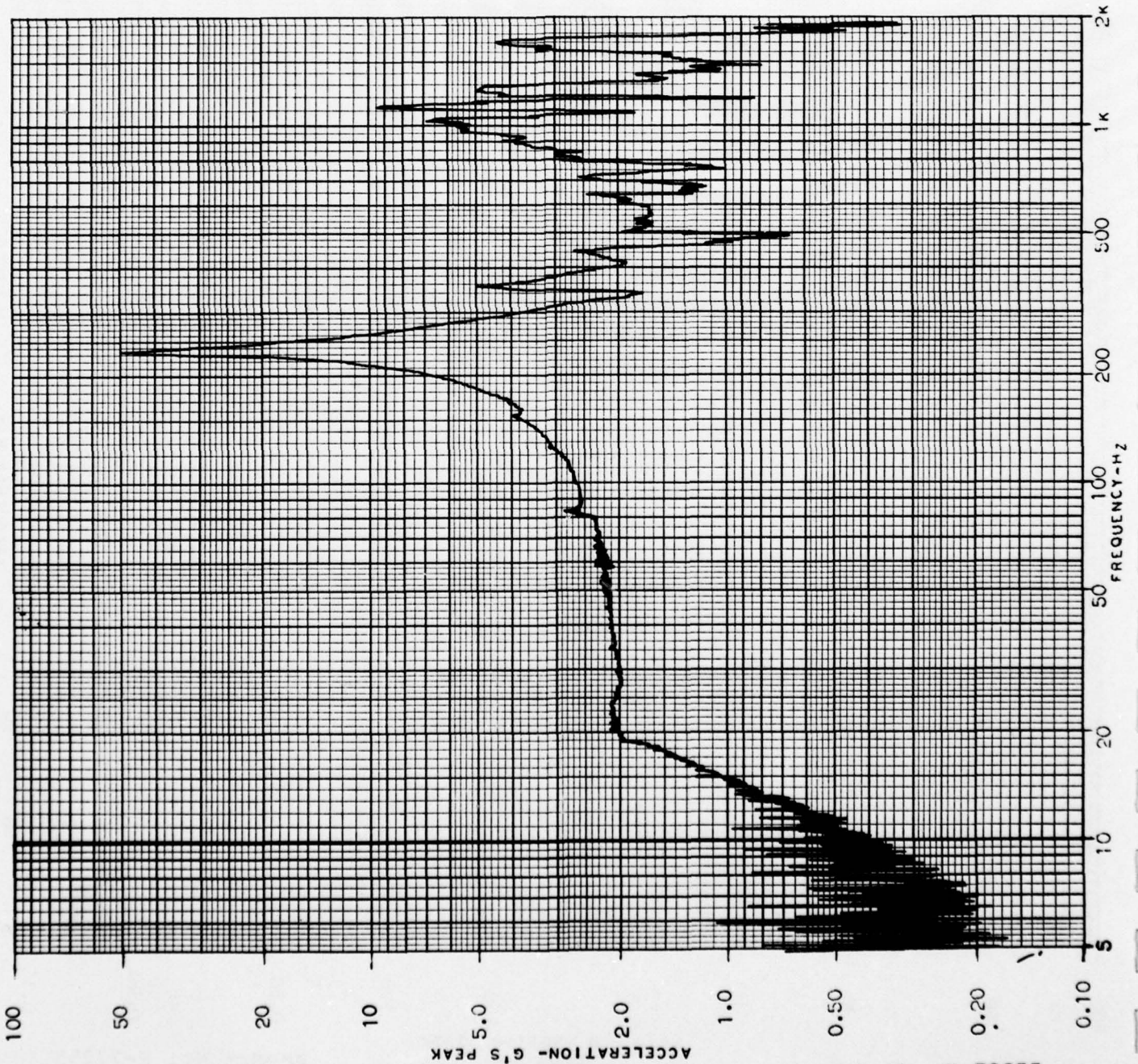

ACCELERATION - G'S PEAK

OGDEN TECHNOLOGY LABORATORIES, INC. (FULLERTON)

VIBRATION TEST DATA

ACCELERATION VS. FREQUENCY

DATE: 10 MAY 72	JOB NO.: F-72255	P.O. NO.: Y6973
SPECIMEN DESCRIPTION: CIRCUIT BOARD ASSY		P/N: 501R329601 S/N: 6617
AXIS: X Y	RUN NO.: 5	ACC. LOCATION: SAMPLE
CUSTOMER: ARINC RESEARCH CORP		ACC. NO.: 2 (RESPONSE)

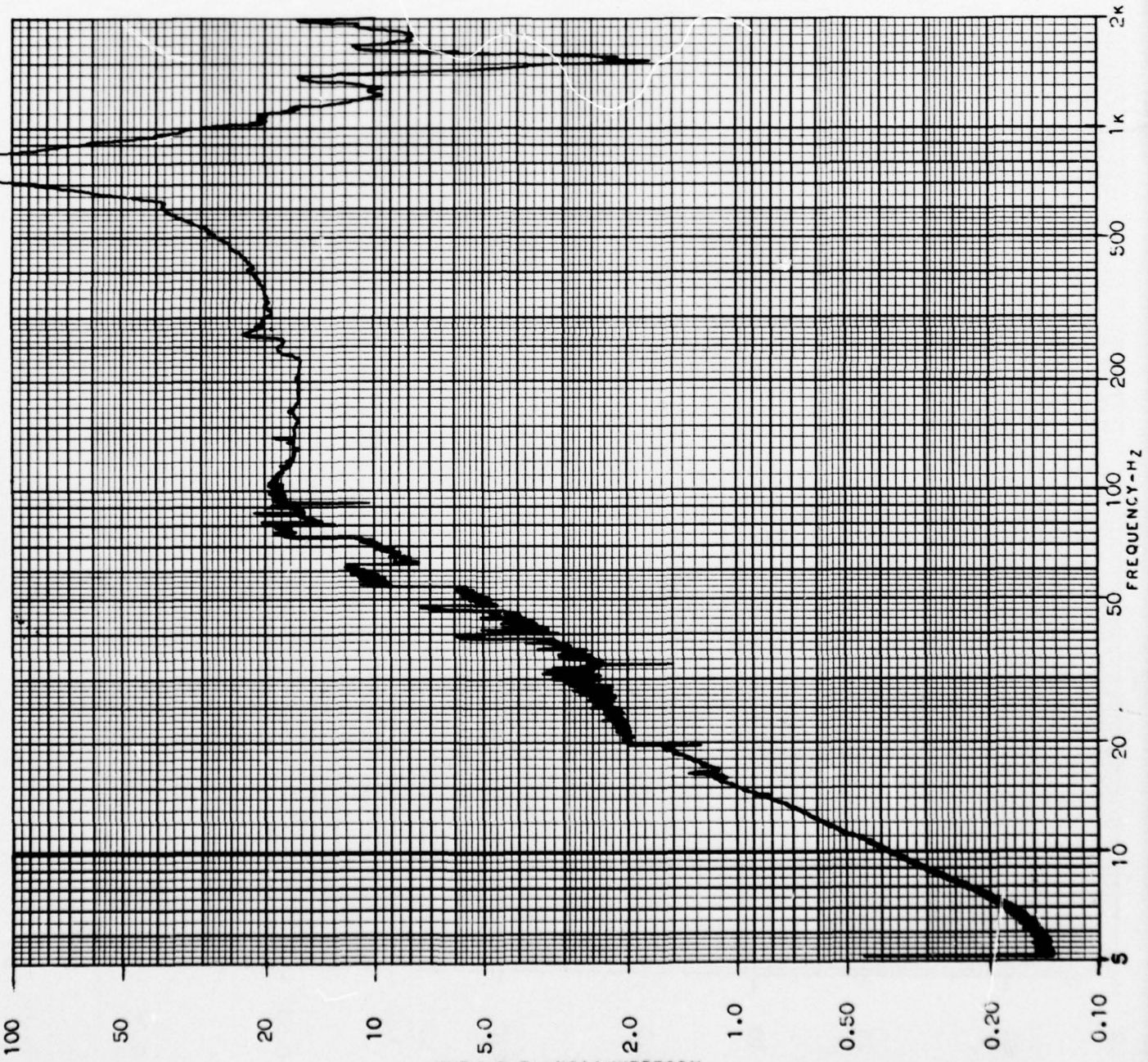

OGDEN TECHNOLOGY LABORATORIES, INC. (FULLERTON)

VIBRATION TEST DATA

ACCELERATION VS. FREQUENCY

DATE: 10 MAY 72	JOB NO.: F-72255	P.O. NO.: Y6973
SPECIMEN DESCRIPTION: CIRCUIT BOARD ASSY	P/N: 501R329601	S/N: 6617
AXIS: Y X	RUN NO.: 6	ACC. LOCATION: SAMPLE
CUSTOMER: ARINC RESEARCH CORP	ACC. NO.: 2 (RESPONSE)	

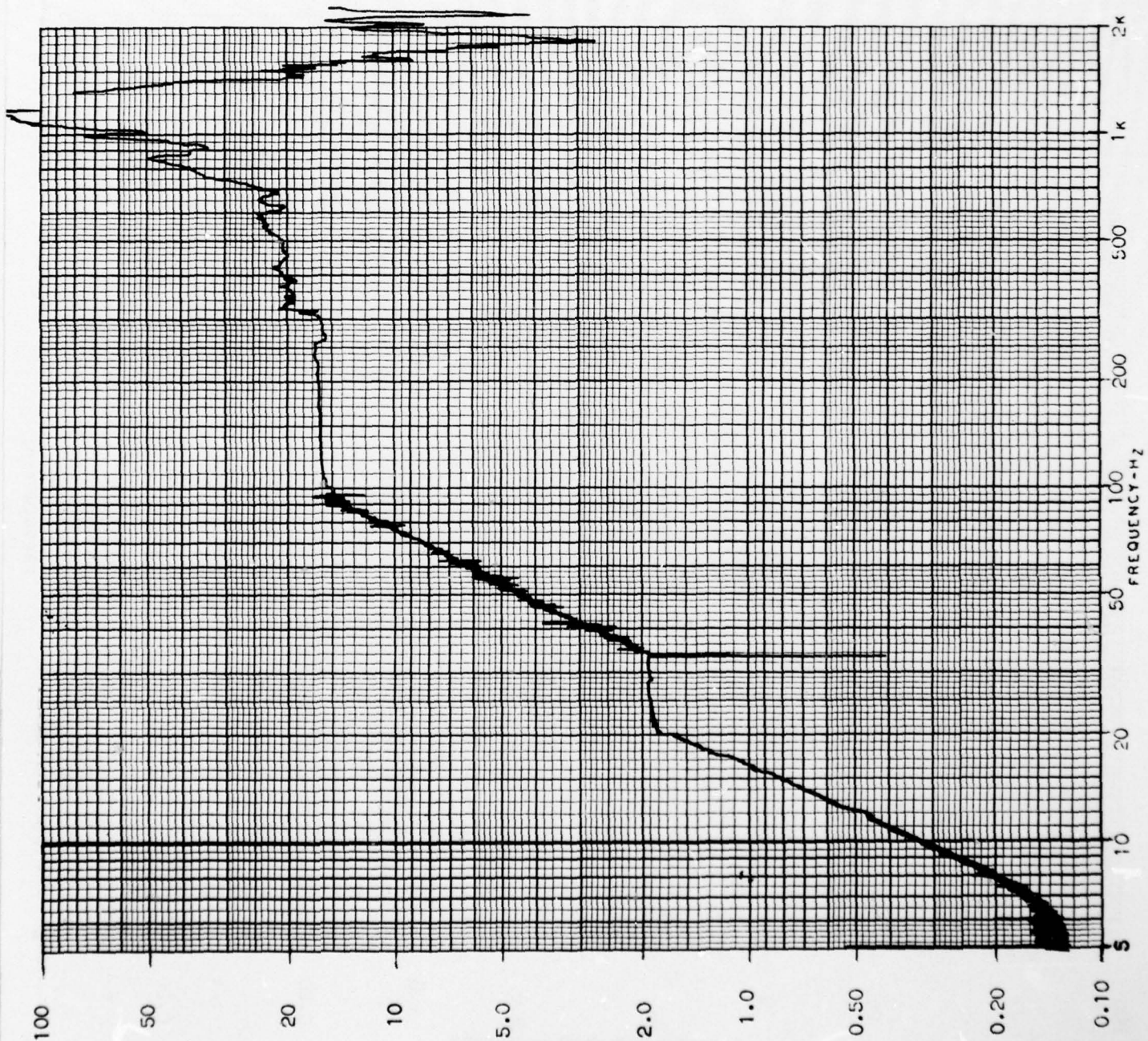

OGDEN TECHNOLOGY LABORATORIES, INC. (FULLERTON)

VIBRATION TEST DATA
ACCELERATION VS. FREQUENCY

DATE: 10 MAY 72 JOB NO.: F-72255 P.O. NO.: Y6973
SPECIMEN DESCRIPTION: CIRCUIT BOARD ASSY. P/N: 501R329601 S/N: 6617
AXIS: Z RUN NO.: 7 ACC. LOCATION: SAMPLE
CUSTOMER: ARINC RESEARCH CORP. ACC. NO.: 2 RESPONSE

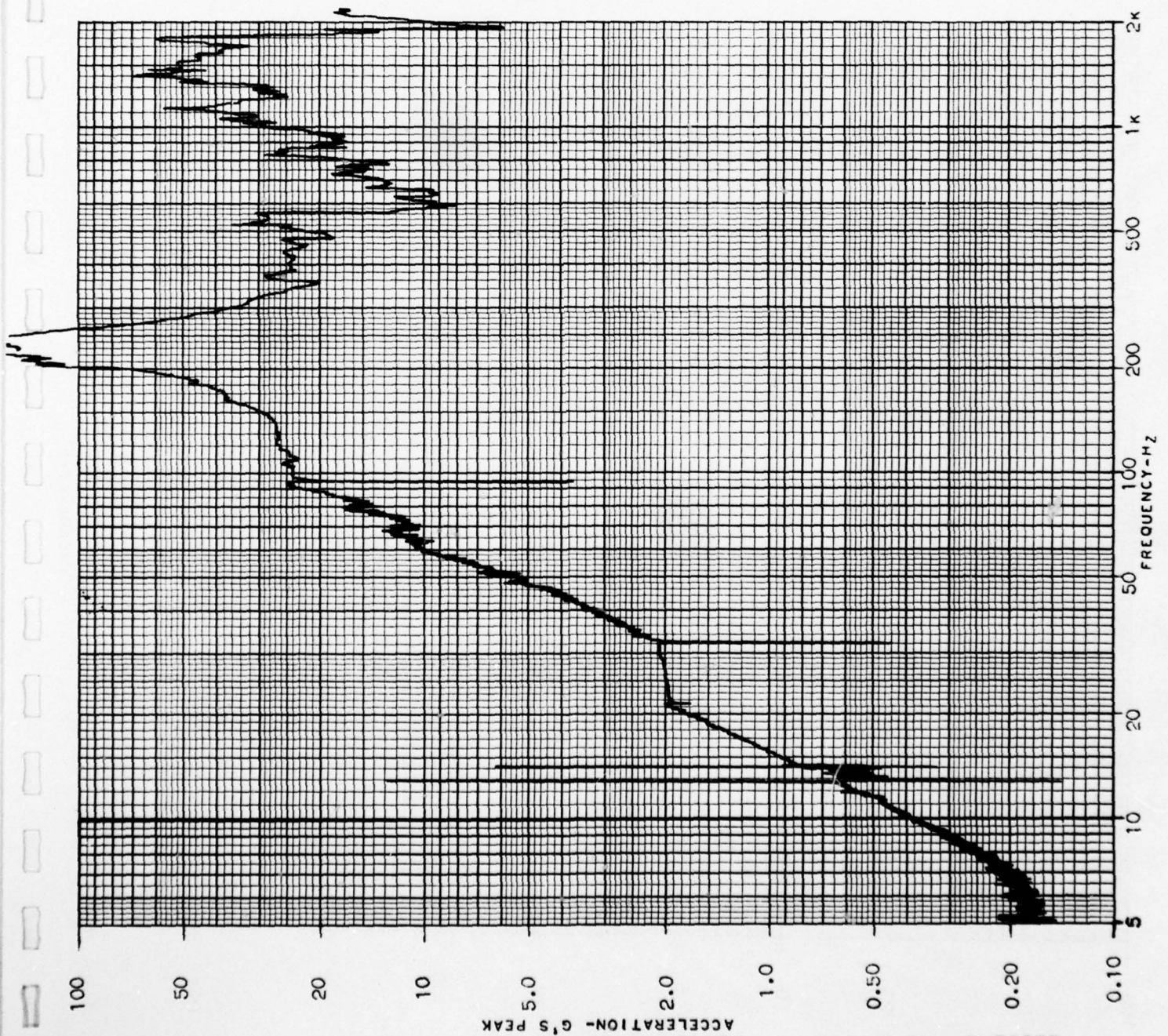

OGDEN TECHNOLOGY LABORATORIES, INC. (FULLERTON)

VIBRATION TEST DATA

ACCELERATION VS. FREQUENCY

DATE: 11 MAY 72 JOB NO.: F-72255 P.O. NO.: Y6973
SPECIMEN DESCRIPTION: CIRCUIT BOARD ASSY P/N: 501R342603 S/N: WSN 6407
AXIS: Y RUN NO.: 8 ACC. LOCATION: SAMPLE
CUSTOMER: ARINC RESEARCH CORP ACC. NO.: 2 (RESPONSE) 1

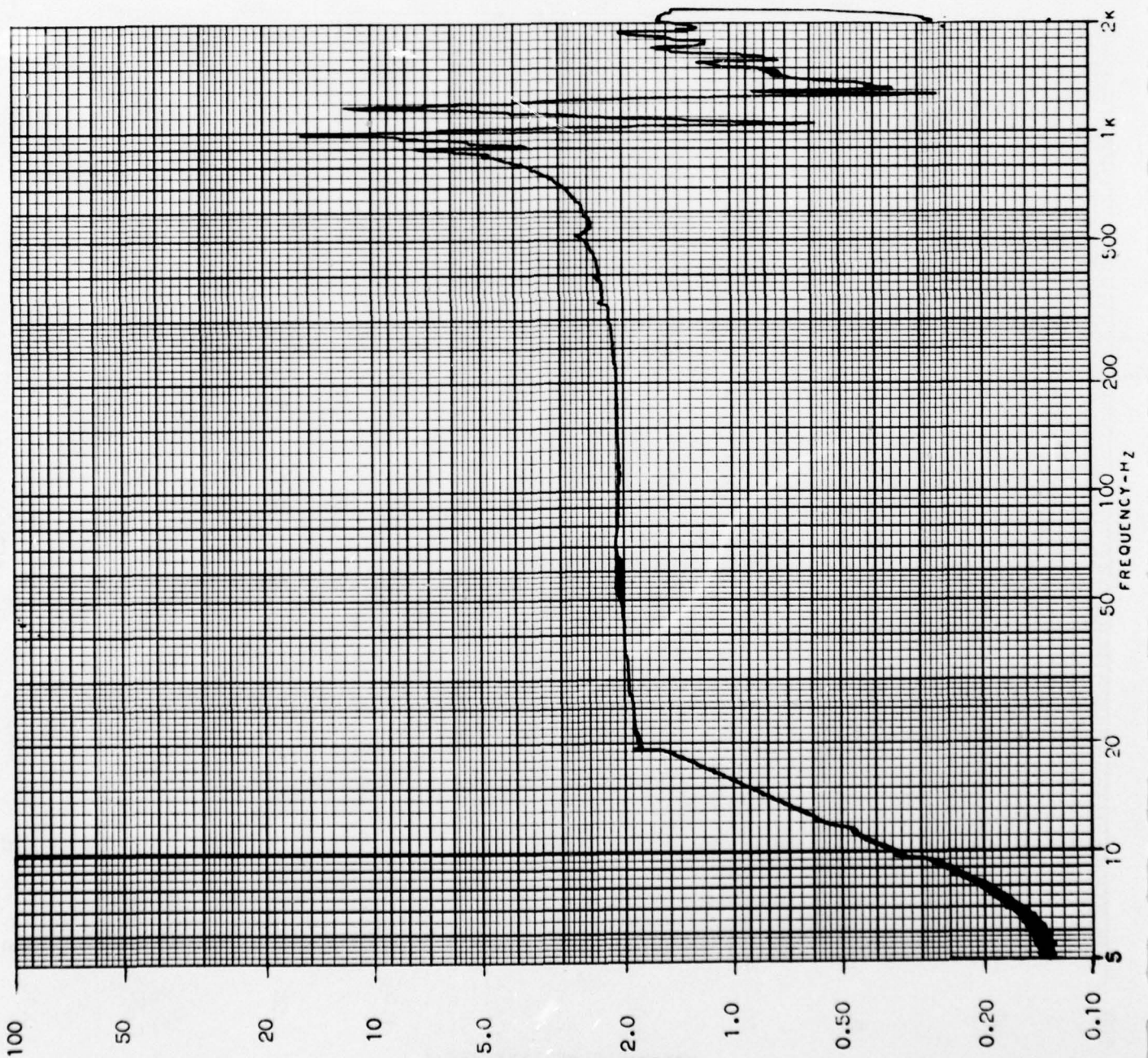

OGDEN TECHNOLOGY LABORATORIES, INC. (FULLERTON)

VIBRATION TEST DATA

ACCELERATION VS. FREQUENCY

DATE: 11 MAY 72 JOB NO.: F-72255 P.O. NO.: Y6973
SPECIMEN DESCRIPTION: CIRCUIT BOARD Assy P/N: 501R342603 S/N: WSN6407
AXIS: X RUN NO.: 9 ACC. LOCATION: SAMPLE
CUSTOMER: ARINC RESEARCH CORP. ACC. NO.: 2 (RESPONSE)

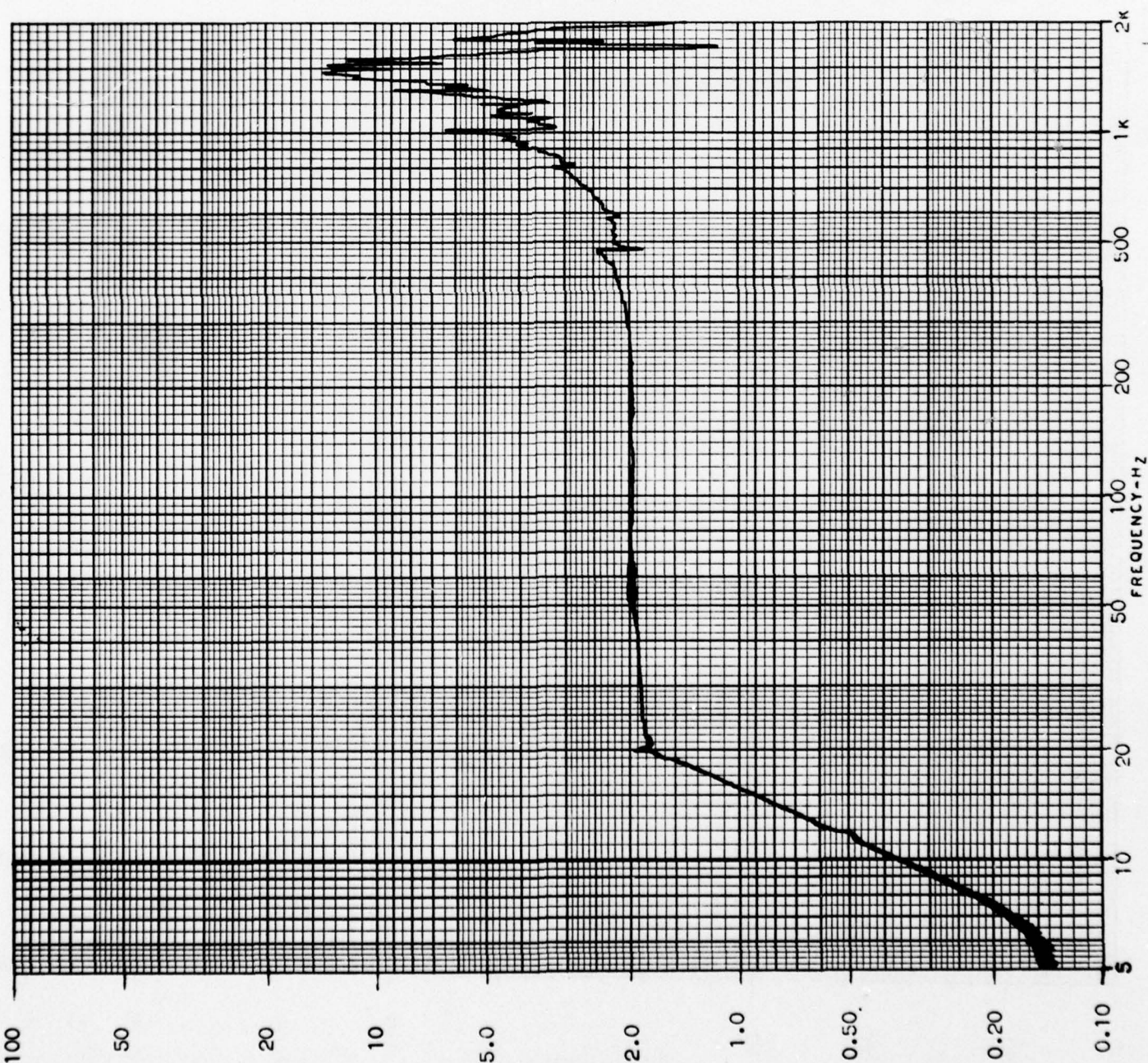

OGDEN TECHNOLOGY LABORATORIES, INC. (FULLERTON)
VIBRATION TEST DATA
ACCELERATION VS. FREQUENCY

DATE: 11 MAY 72 JOB NO.: F-72255 P.O. NO.: Y6973
SPECIMEN DESCRIPTION: CIRCUIT BOARD ASSY P/N: 501R342603 S/N: WSN 6407
AXIS: Z RUN NO.: 10 ACC. LOCATION: SAMPLE
CUSTOMER: ARINC RESEARCH CORP. ACC. NO.: 2 (RESPONSE)

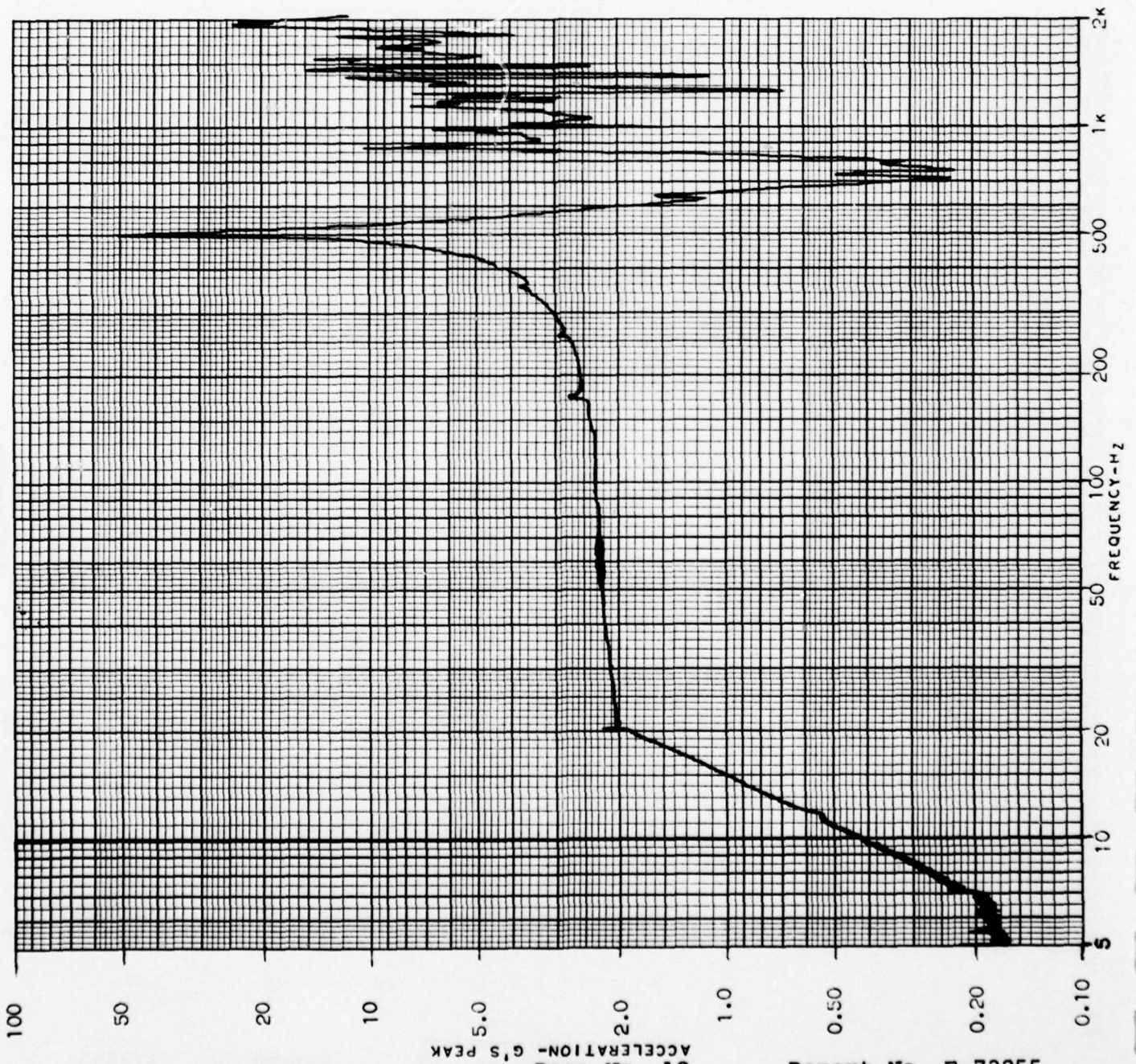

OGDEN TECHNOLOGY LABORATORIES, INC. (FULLERTON)

VIBRATION TEST DATA

ACCELERATION VS. FREQUENCY

DATE: 11 MAY 72	JOB NO.: F-72255	P.O. NO.: Y6973
SPECIMEN DESCRIPTION: CIRCUIT BOARD ASSY	P/N: 501R342G03	S/N: WSN 6407
AXIS: Y	RUN NO.: 11	ACC. LOCATION: SAMPLE
CUSTOMER: ARINC RESEARCH CORP.		ACC. NO.: 2 (RESPONSE)

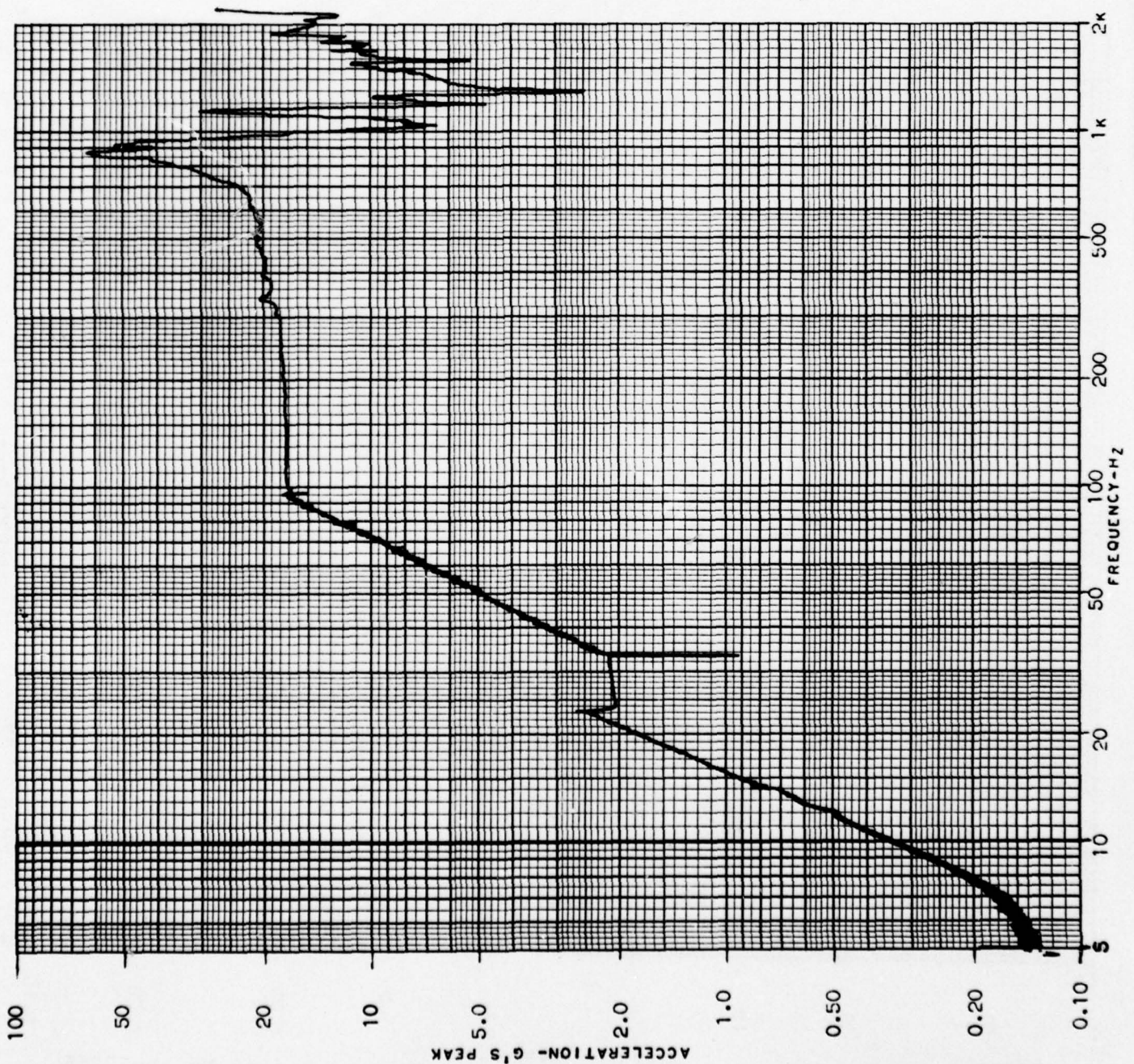

ACCELERATION - G'S PEAK

OGDEN TECHNOLOGY LABORATORIES, INC. (FULLERTON)
VIBRATION TEST DATA
ACCELERATION VS. FREQUENCY

DATE: 11 MAY 72 JOB NO.: F-72255 P.O. NO.: Y 6973
SPECIMEN DESCRIPTION: CIRCUIT BOARD Assy P/N: 501R342603 S/N: WSN 6407
AXIS: X RUN NO.: 12 ACC. LOCATION: SAMPLE
CUSTOMER: ARINC RESEARCH CORP. ACC. NO.: 2 (RESPONSE)

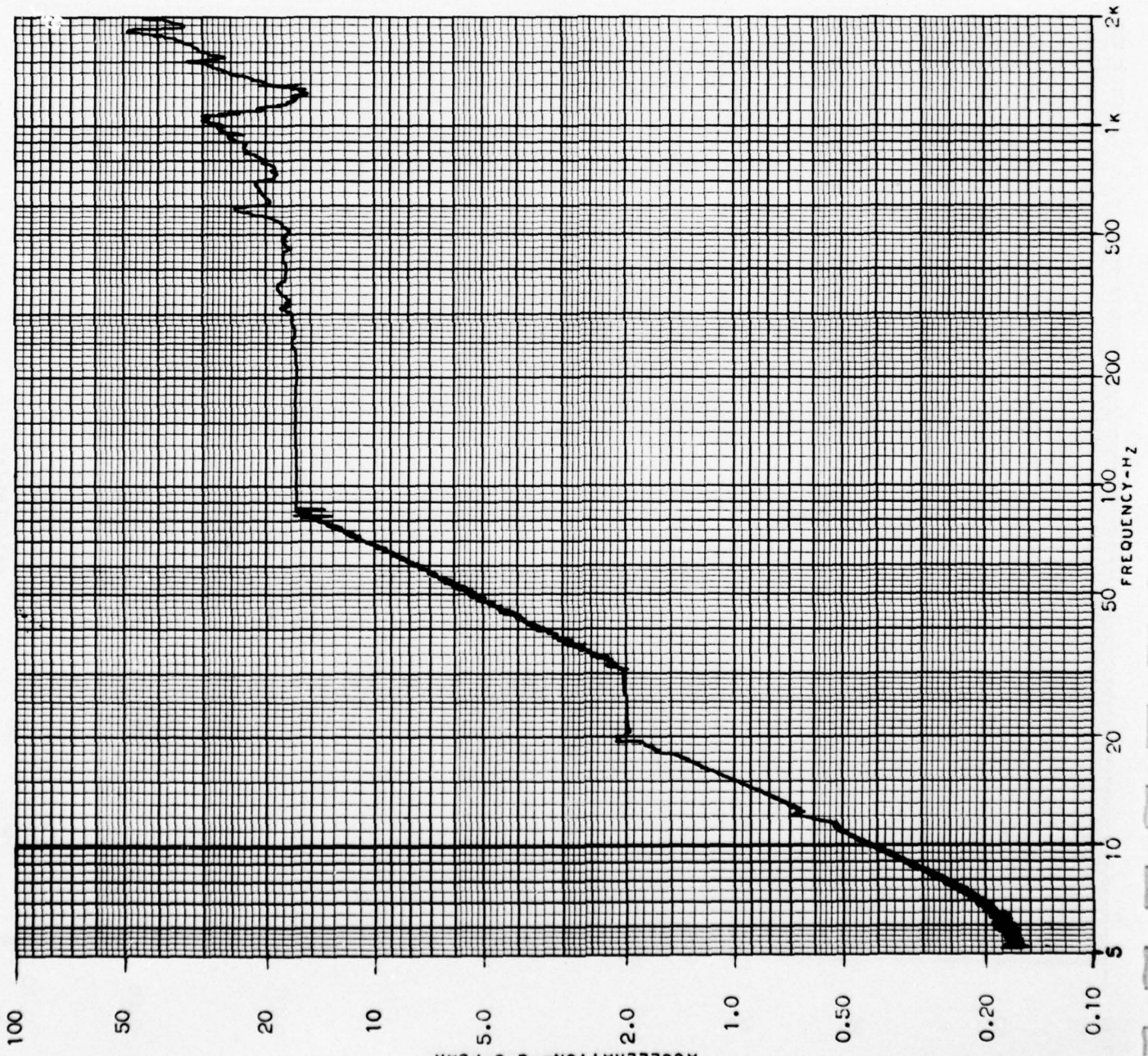

OGDEN TECHNOLOGY LABORATORIES, INC. (FULLERTON)

VIBRATION TEST DATA
ACCELERATION VS. FREQUENCY

DATE: 11 MAY 72 JOB NO.: F-72255 P.O. NO.: Y6973
SPECIMEN DESCRIPTION: CIRCUIT BOARD ASSY P/N: 501R342602 S/N: WSN 6407
AXIS: Z RUN NO.: 13 ACC. LOCATION: SAMPLE
CUSTOMER: ARINC RESEARCH CORP. ACC. NO.: 2 (RESPONSE)

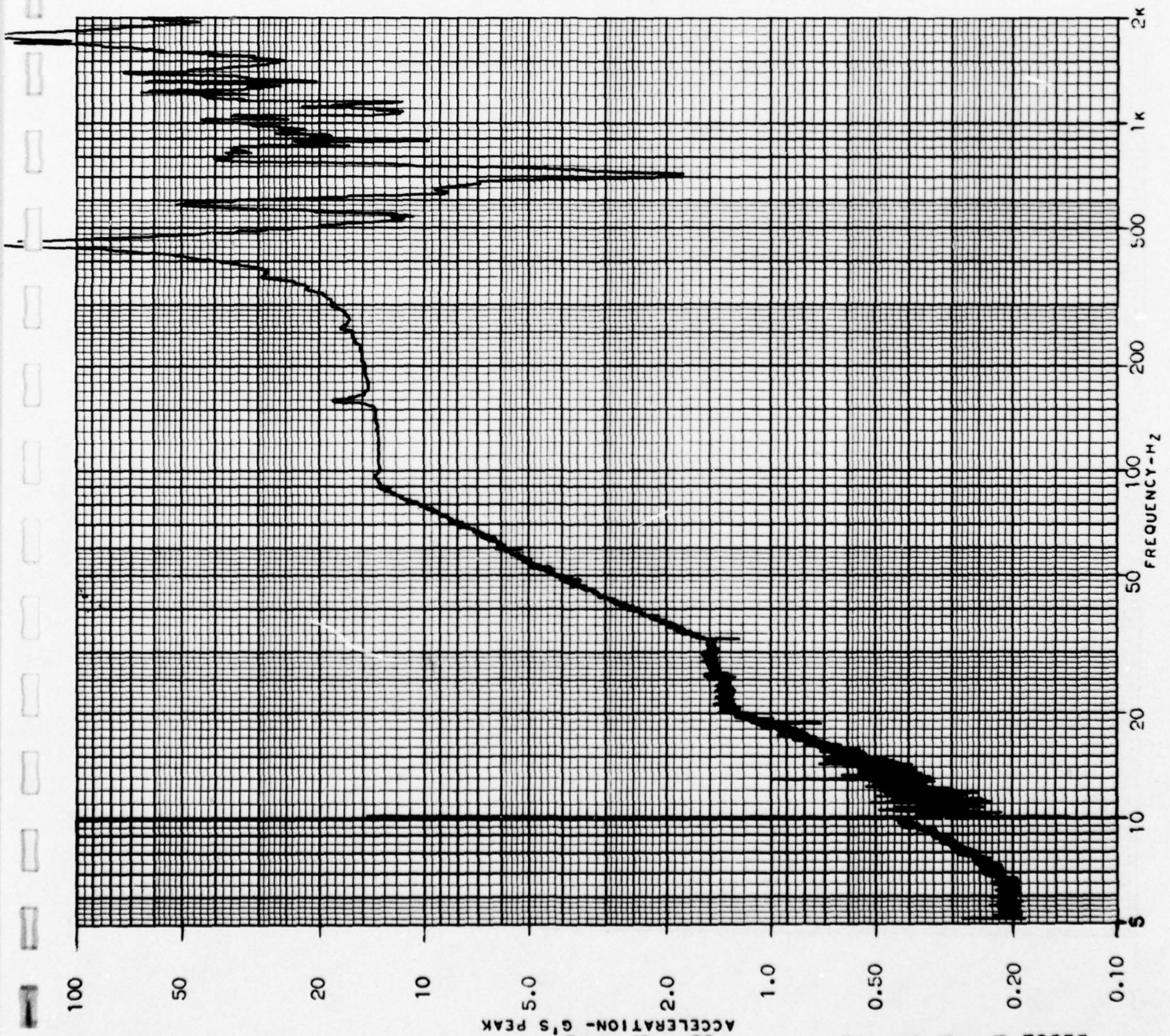

OGDEN TECHNOLOGY LABORATORIES, INC. (FULLERTON)

VIBRATION TEST DATA
ACCELERATION VS. FREQUENCY

DATE: 11 MAY 72 JOB NO.: F-72255 P.O. NO.: Y6973
SPECIMEN DESCRIPTION: CIRCUIT BOARD ASSY P/N: 50/R343602 S/N: WSN 7421
AXIS: Y RUN NO.: 14 ACC. LOCATION: SAMPLE
CUSTOMER: ARINC RESEARCH CORP. ACC. NO.: 2 (RESPONSE)

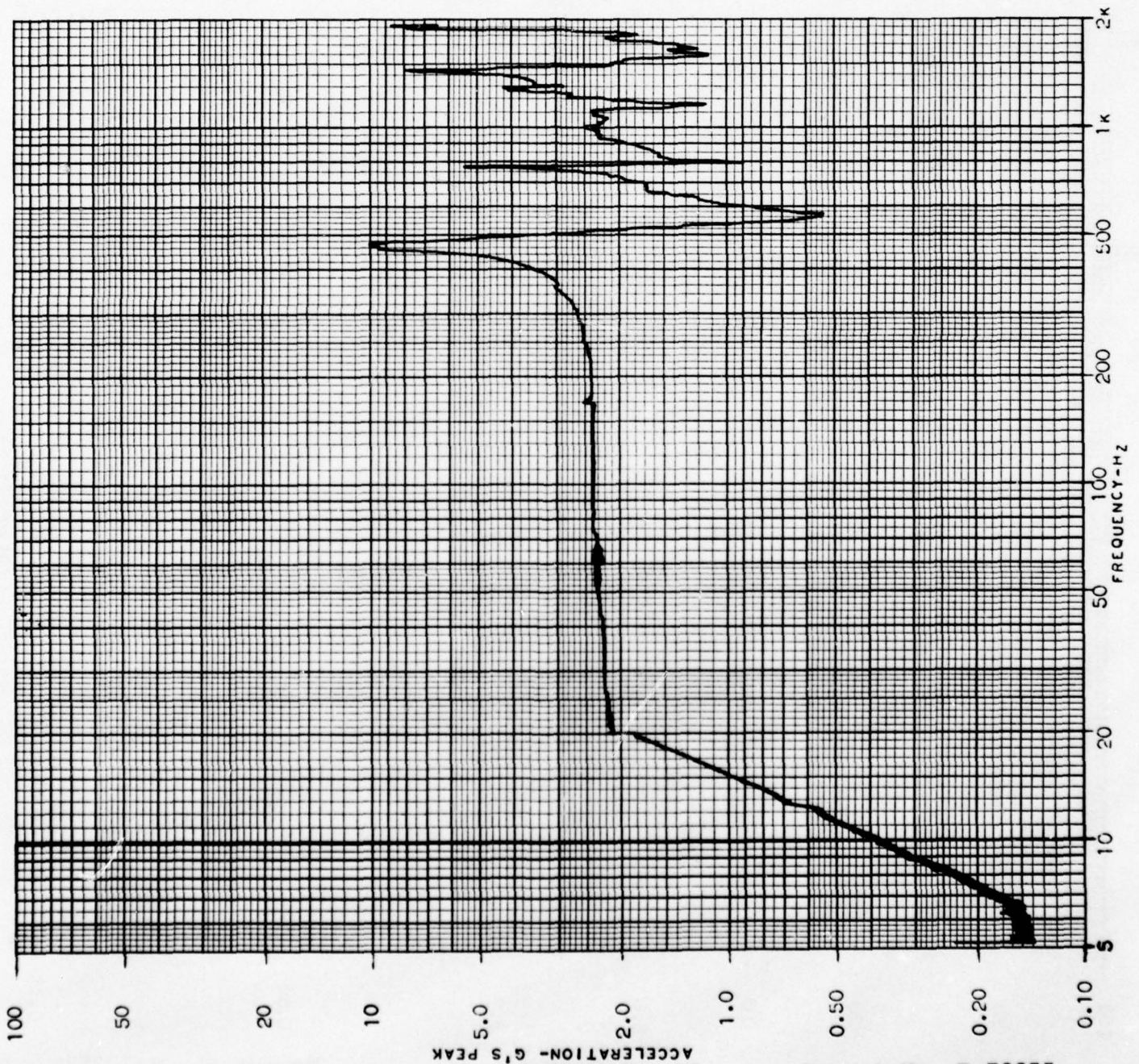

OGDEN TECHNOLOGY LABORATORIES, INC. (FULLERTON)

VIBRATION TEST DATA
ACCELERATION VS. FREQUENCY

DATE: 11 MAY 72 JOB NO.: F-72255 P.O. NO.: Y6973
SPECIMEN DESCRIPTION: CIRCUIT BOARD ASSY P/N: 501R343602 S/N: WSN 7471
AXIS: X RUN NO.: 15 ACC. LOCATION: SAMPLE
CUSTOMER: ARINC RESEARCH CORP ACC. NO.: 2 (RESPONSE)

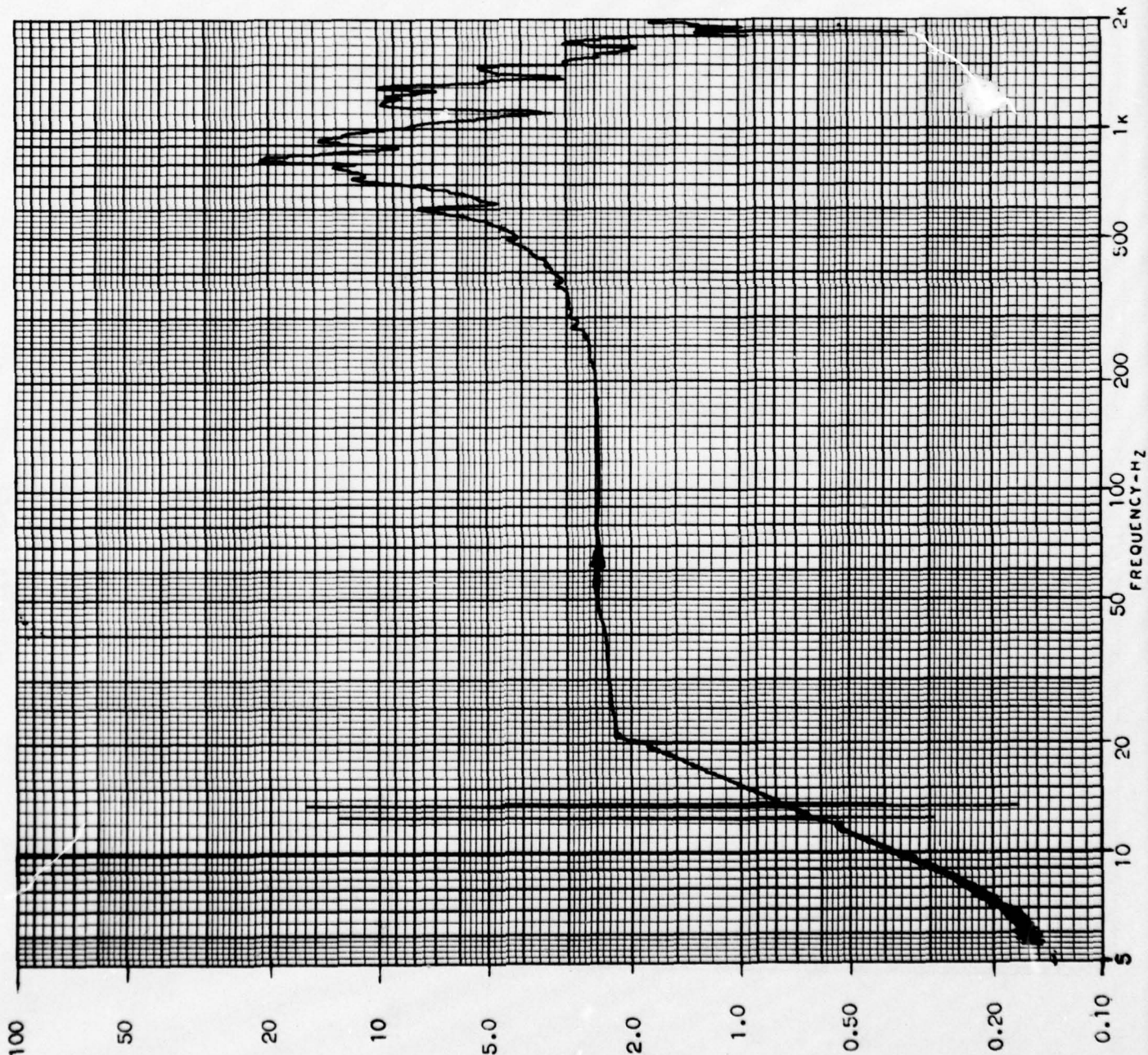

OGDEN TECHNOLOGY LABORATORIES, INC. (FULLERTON)
VIBRATION TEST DATA
ACCELERATION VS. FREQUENCY

DATE: 11 MAY 72	JOB NO.: F-72255	P.O. NO.: 46975
SPECIMEN DESCRIPTION: CIRCUIT BOARD ASSY	P/N: 50R343G02	S/N: WSN 7471
AXIS: Z	RUN NO.: 16	ACC. LOCATION: SAMPLE
CUSTOMER: ARINC RESEARCH CORP.	ACC. NO.: 2 (RESPONSE)	

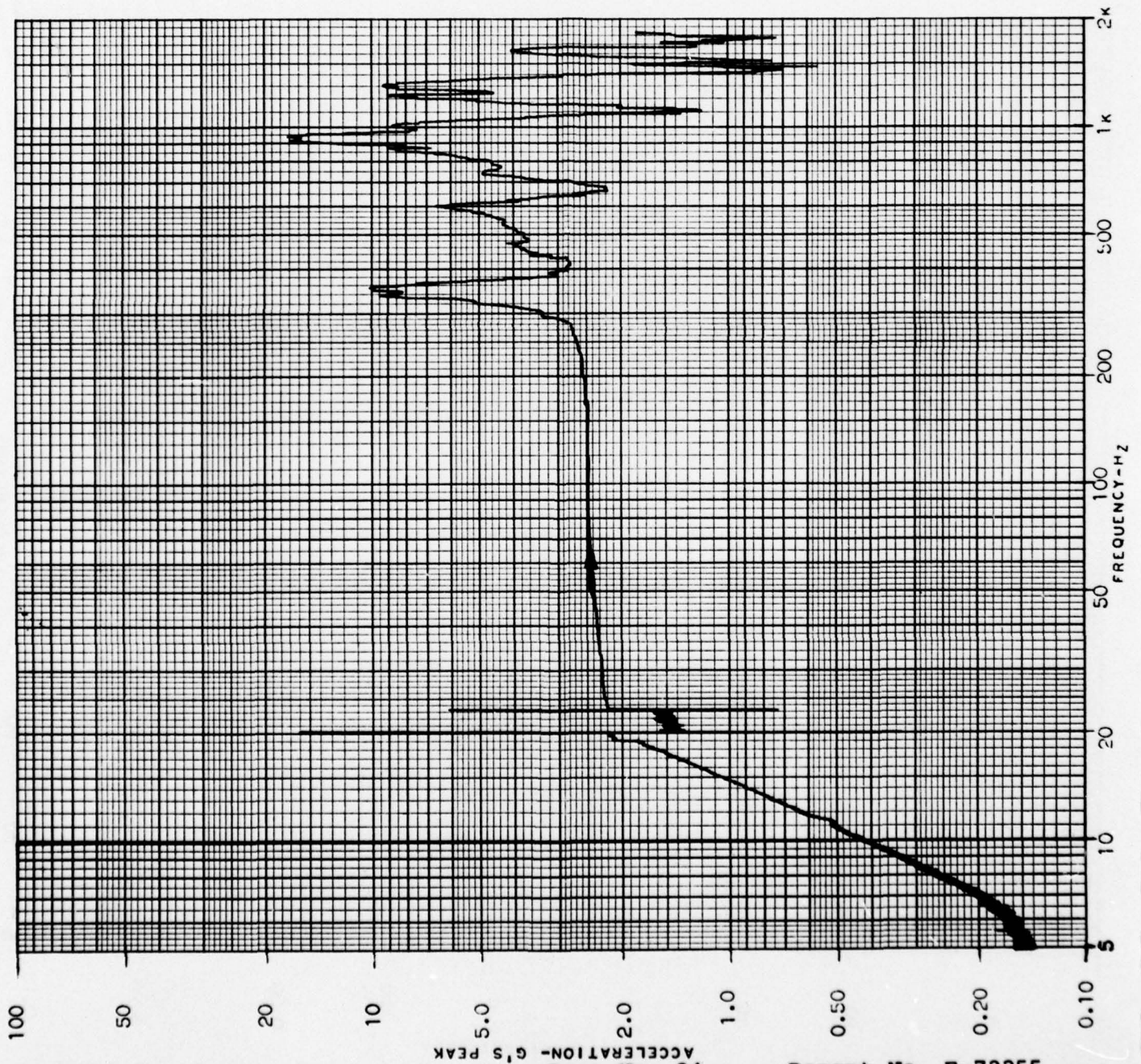

OGDEN TECHNOLOGY LABORATORIES, INC. (FULLERTON)

VIBRATION TEST DATA
ACCELERATION VS. FREQUENCY

DATE: 11 MAY 72 JOB NO.: F-72255 P.O. NO.: y 6973
SPECIMEN DESCRIPTION: CIRCUIT BOARD ASSY. P/N: 501R3F3G02 S/N: WSN 7471
AXIS: y RUN NO.: 17 ACC. LOCATION: SAMPLE
CUSTOMER: ARINC RESEARCH CORP. ACC. NO.: 2 (RESPONSE)

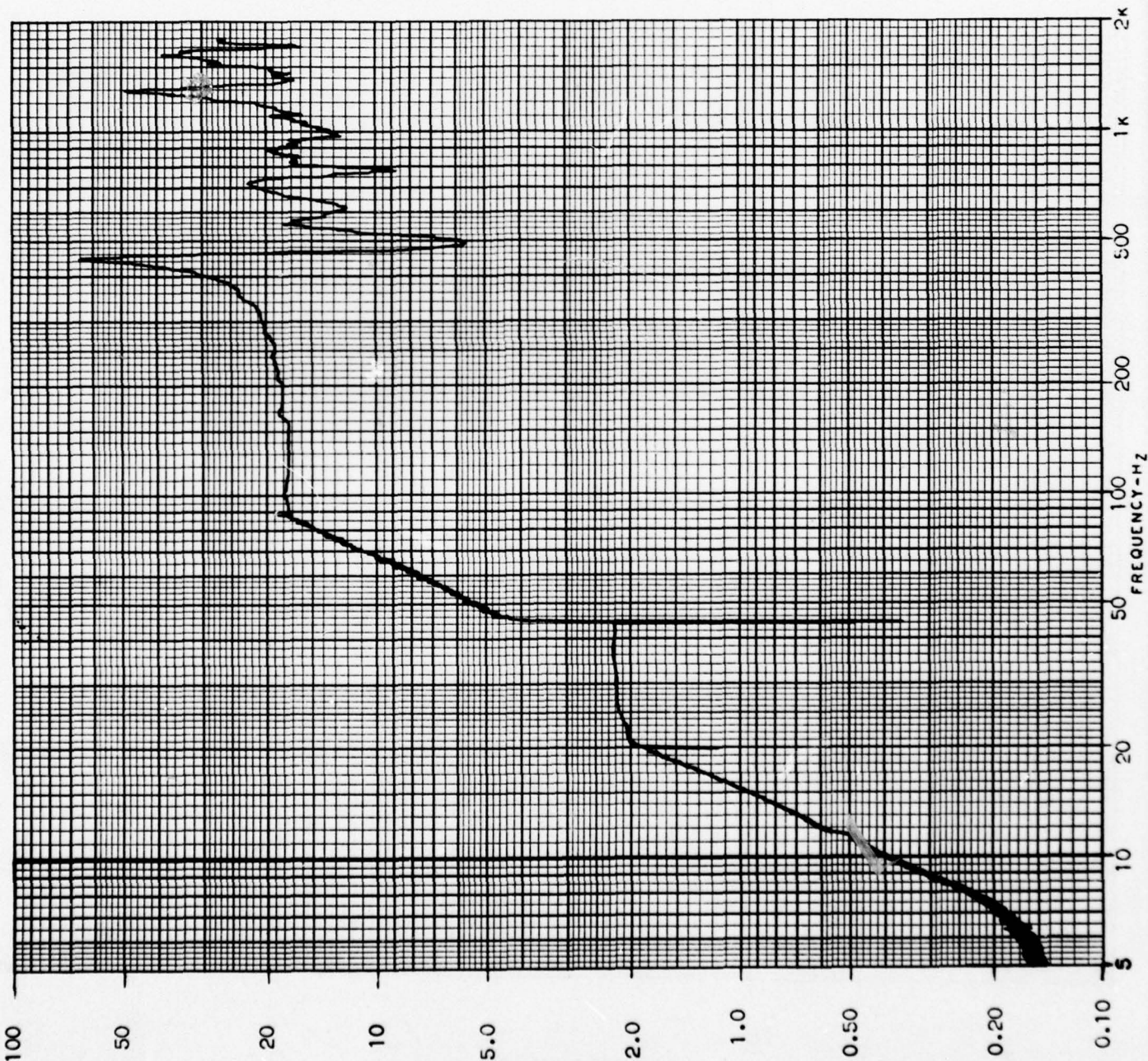

OGDEN TECHNOLOGY LABORATORIES, INC. (FULLERTON)

VIBRATION TEST DATA

ACCELERATION VS. FREQUENCY

DATE: 11 MAY 72	JOB NO.: F-72255	P.O. NO.: Y6973
SPECIMEN DESCRIPTION: CIRCUIT BOARD ASSY	P/N: 501R343G02	S/N: WSN 7471
AXIS: X	RUN NO.: 18	ACC. LOCATION: SAMPLE
CUSTOMER: ARINC RESEARCH CORP.		ACC. NO.: 2 (RESPONSE)

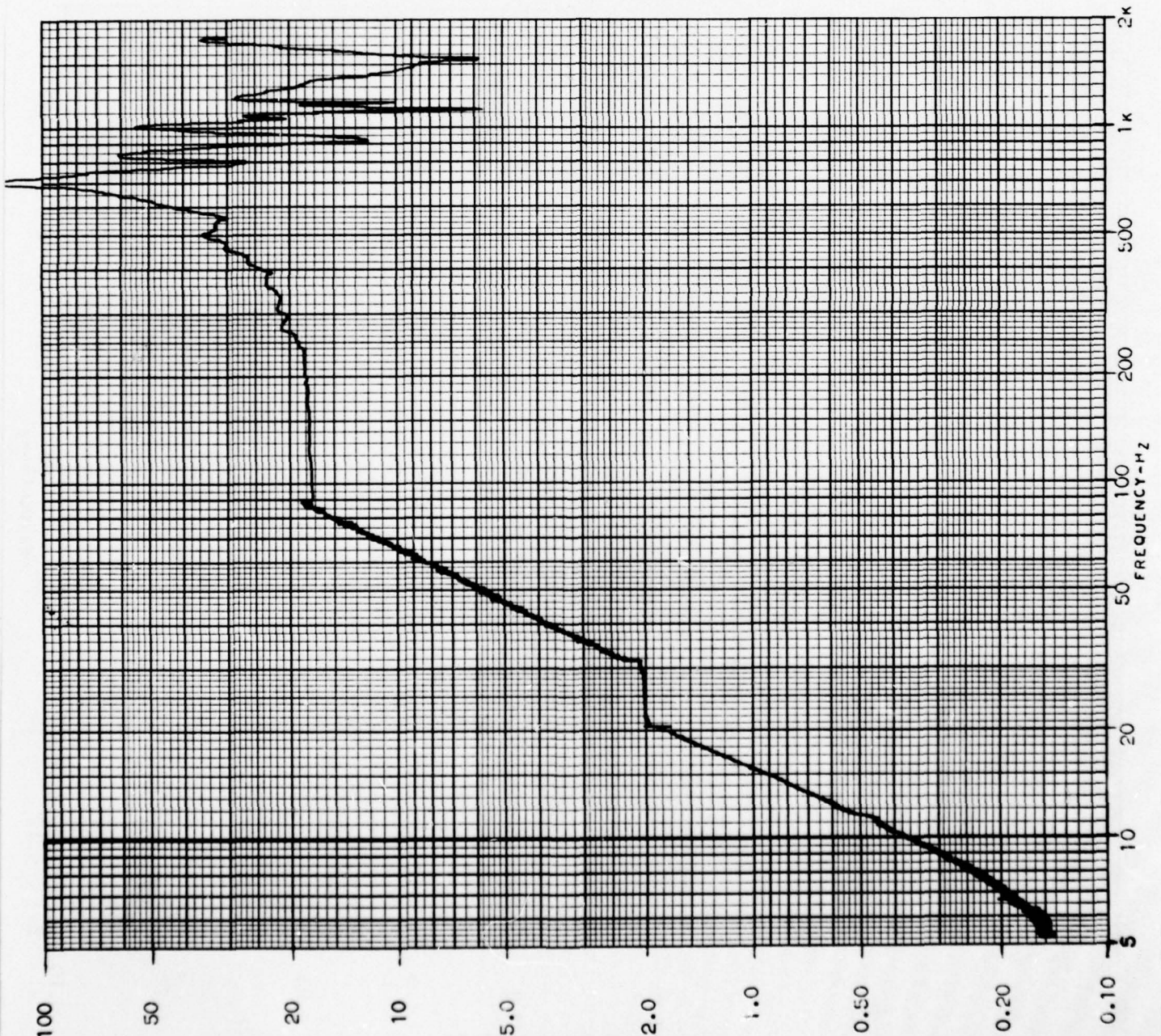

OGDEN TECHNOLOGY LABORATORIES, INC. (FULLERTON)

VIBRATION TEST DATA
ACCELERATION VS. FREQUENCY

DATE: 11 MAY 72	JOB NO.: F-72255	P.O. NO.: Y6973
SPECIMEN DESCRIPTION: CIRCUIT BOARD ASSY	P/N: 5dR3d3G02	S/N: WSN 7471
AXIS: -Z	RUN NO.: 19	ACC. LOCATION: SAMPLE
CUSTOMER: ARINC RESEARCH CORP.	ACC. NO.: 2 (RESPONSE)	

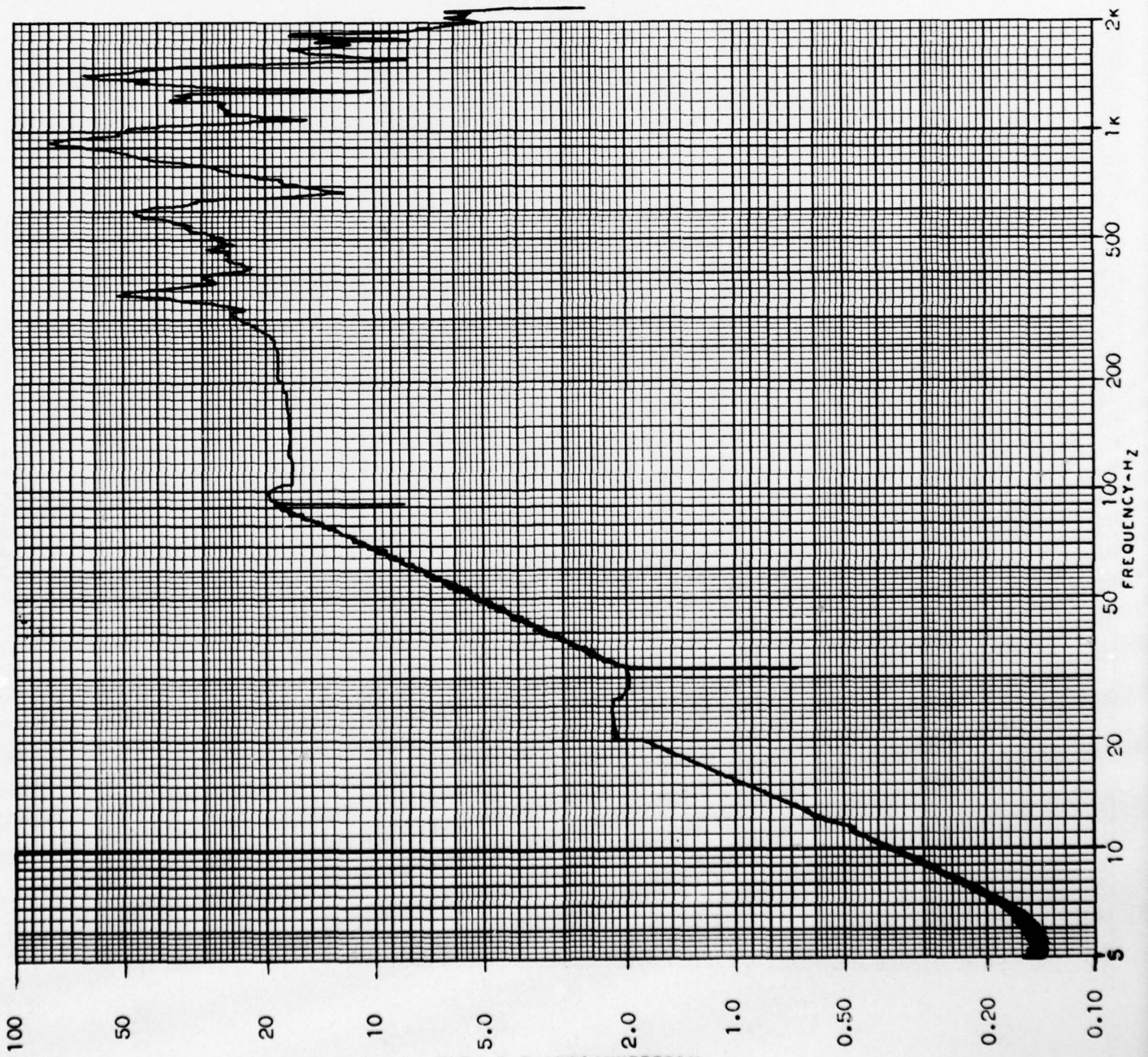

OGDEN TECHNOLOGY LABORATORIES, INC. (FULLERTON)

VIBRATION TEST DATA

ACCELERATION VS. FREQUENCY

DATE: 11 MAY 72 JOB NO.: F-72255 P.O. NO.: Y 6973
SPECIMEN DESCRIPTION: CIRCUIT BOARD ASSY P/N: 501R327602 S/N: FN 6668
AXIS: Z RUN NO.: 20 ACC. LOCATION: SAMPLE
CUSTOMER: ARINC RESEARCH CORP. ACC. NO.: 2 (RESPONSE)

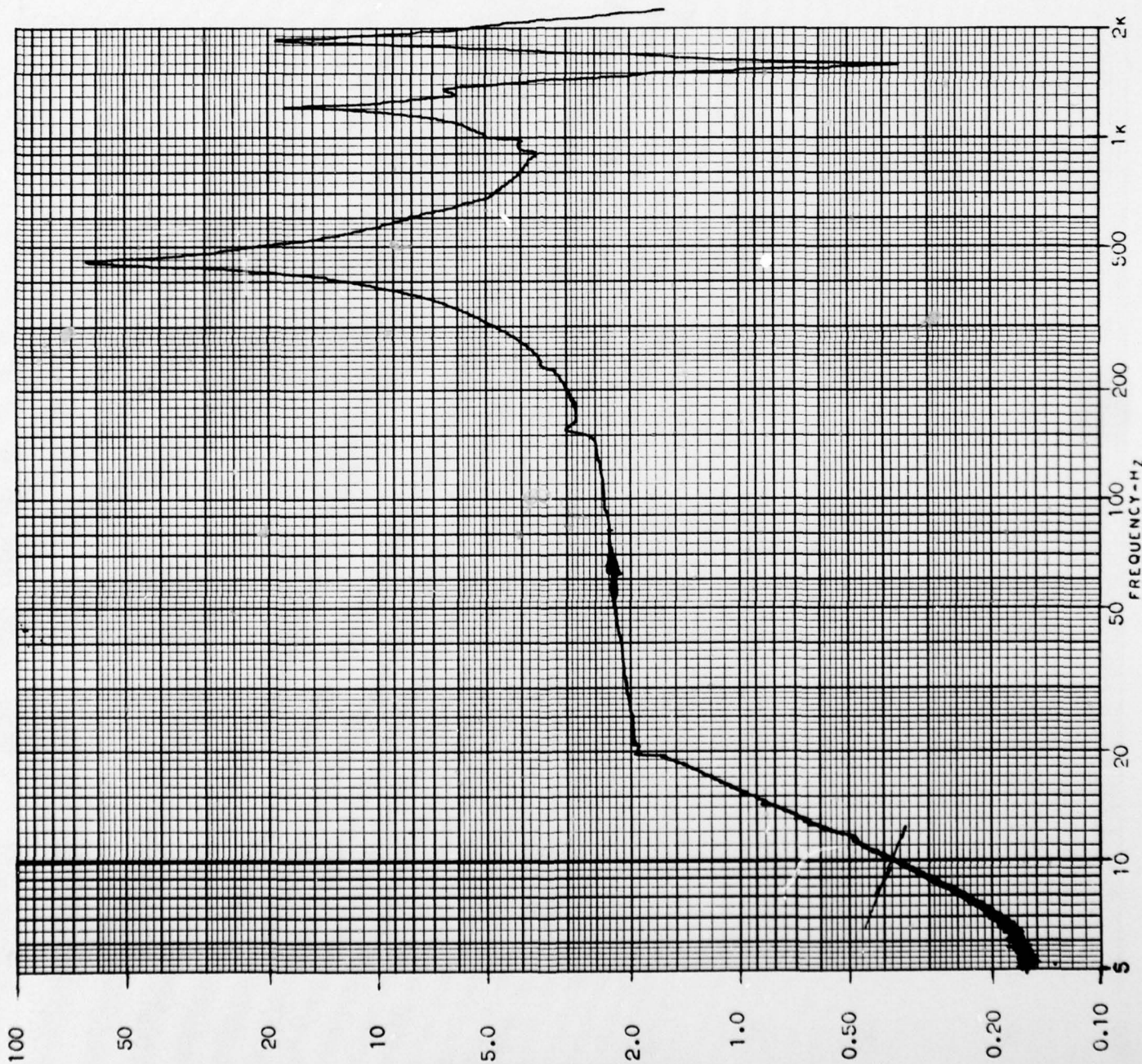

OGDEN TECHNOLOGY LABORATORIES, INC. (FULLERTON)

VIBRATION TEST DATA
ACCELERATION VS. FREQUENCY

DATE: 11 MAY 72 JOB NO.: F-72255 P.O. NO.: Y 6973
SPECIMEN DESCRIPTION: CIRCUIT BOARD ASSY P/N: 501R327G02 S/N: FN6668
AXIS: X RUN NO.: 21 ACC. LOCATION: SAMPLE
CUSTOMER: ARINC RESEARCH CORP. ACC. NO.: 2 (RESPONSE)

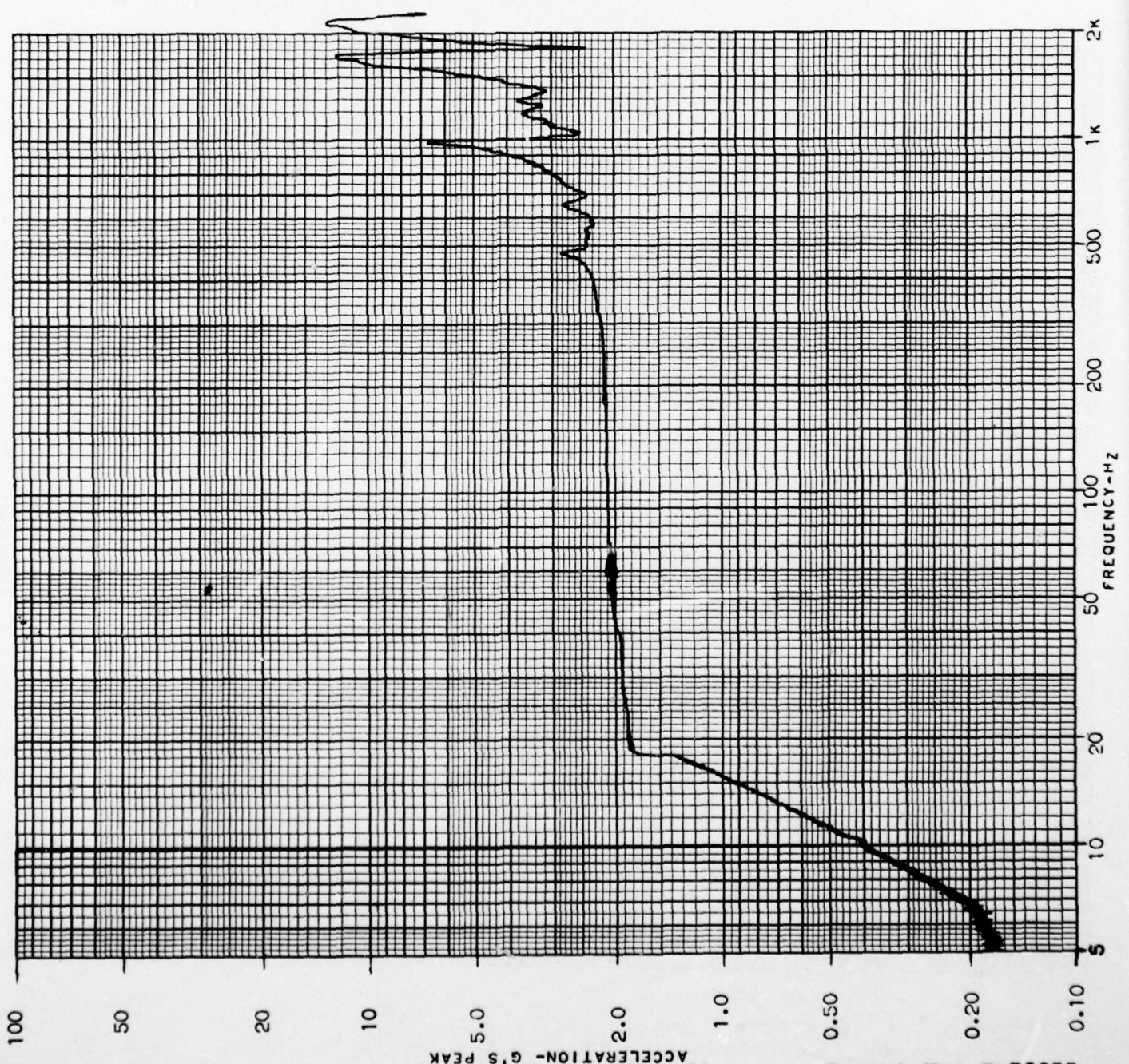

OGDEN TECHNOLOGY LABORATORIES, INC. (FULLERTON)

VIBRATION TEST DATA

ACCELERATION VS. FREQUENCY

DATE: 12 MAY 72 JOB NO.: F-72255 P.O. NO.: Y 6973
SPECIMEN DESCRIPTION: CIRCUIT BOARD ASSY P/N: 501R327602 S/N: FN 6668
AXIS: Y RUN NO.: 22 ACC. LOCATION: SAMPLE
CUSTOMER: ARINC RESEARCH CORP. ACC. NO.: 2 (RESPONSE)

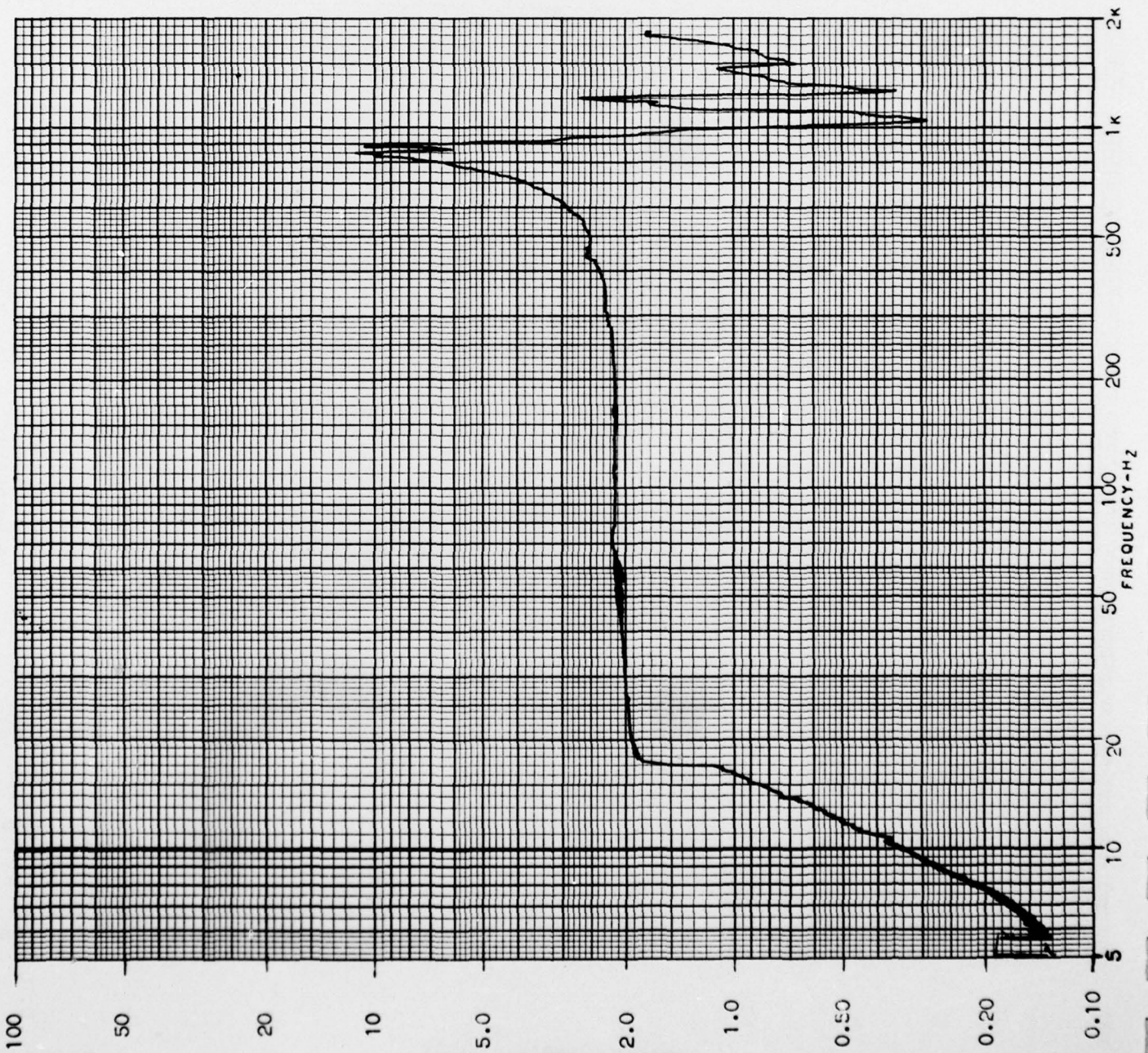

OGDEN TECHNOLOGY LABORATORIES, INC. (FULLERTON)
VIBRATION TEST DATA
ACCELERATION VS. FREQUENCY

DATE: 12 MAY 72 JOB NO.: F-72255 P.O. NO.: Y 6973
SPECIMEN DESCRIPTION: CIRCUIT BOARD ASSY. P/N: 501R327G02 S/N: FN6668
AXIS: Y RUN NO.: 23 ACC. LOCATION: SAMPLE
CUSTOMER: ARINC RESEARCH CORP. ACC. NO.: 2 (RESPONSE)

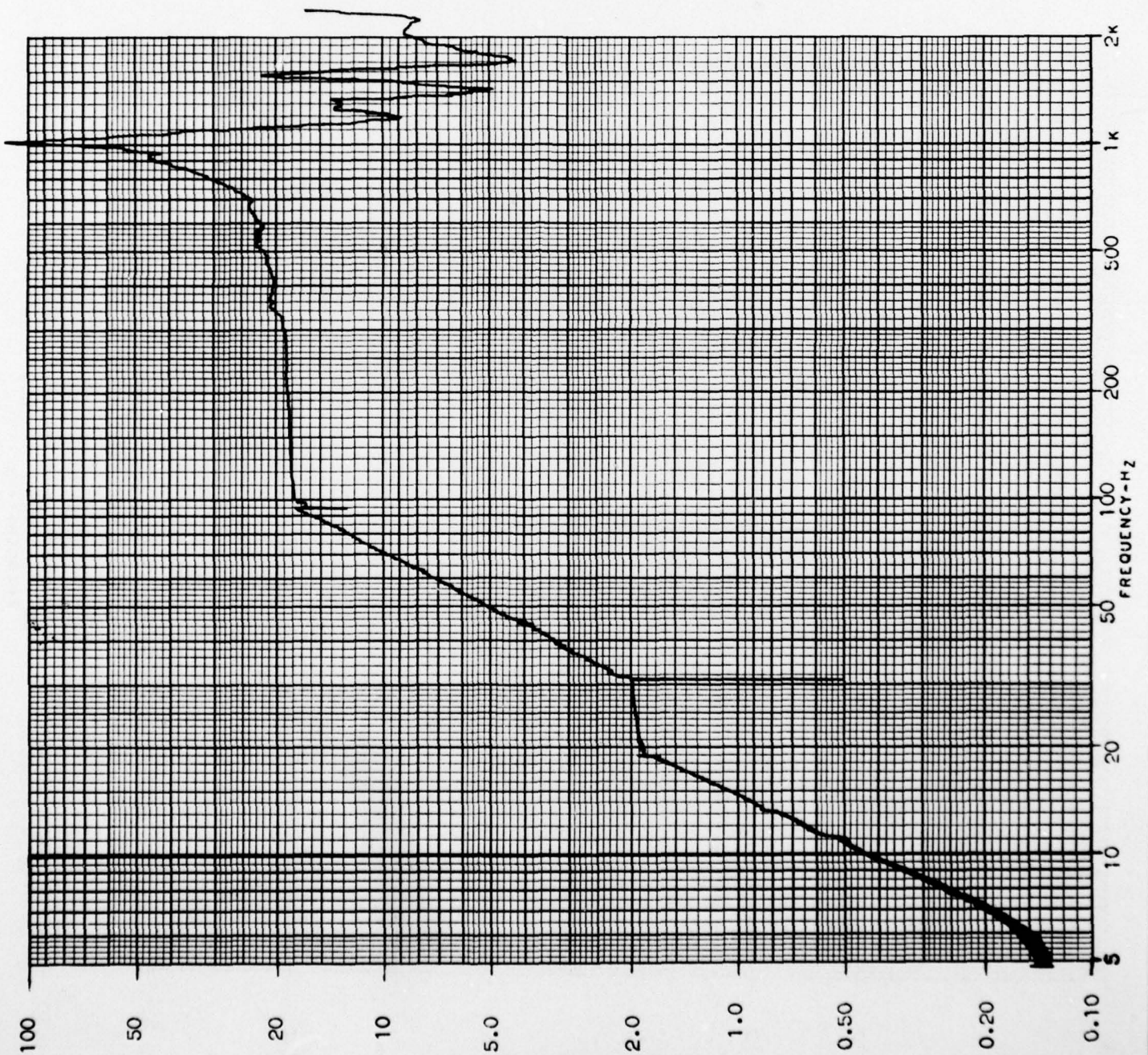

OGDEN TECHNOLOGY LABORATORIES, INC. (FULLERTON)

VIBRATION TEST DATA

ACCELERATION VS. FREQUENCY

DATE: 12 MAY 72 JOB NO.: F-72255 P.O. NO.: Y6973
SPECIMEN DESCRIPTION: CIRCUIT BOARD ASY. P/N: S/N:
AXIS: X RUN NO.: 24 ACC. LOCATION: SAMPLE
CUSTOMER: ARINC RESEARCH CORP ACC. NO.: 2 (RESPONSE)

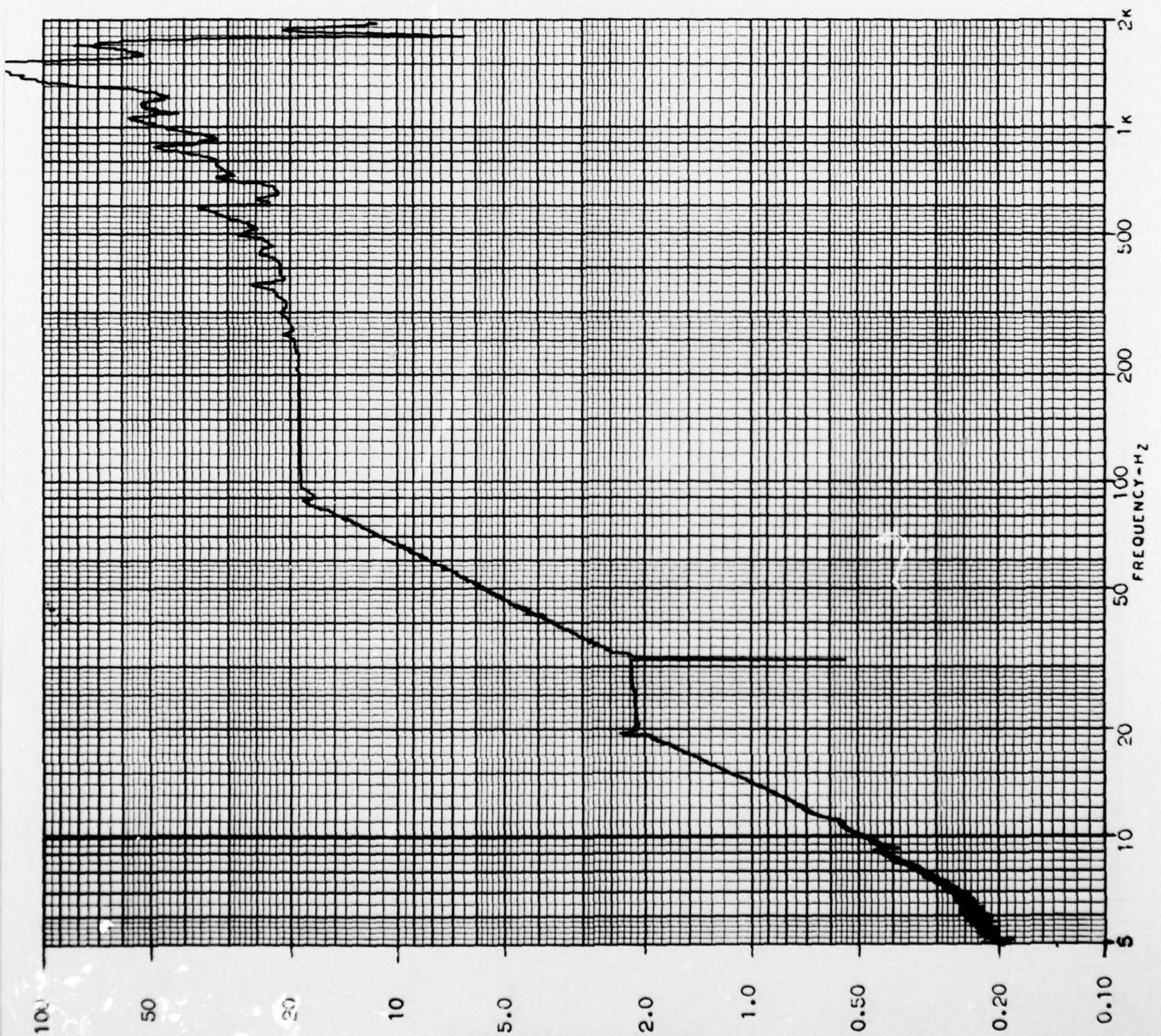

OGDEN TECHNOLOGY LABORATORIES, INC. (FULLERTON)

VIBRATION TEST DATA
ACCELERATION VS. FREQUENCY

DATE: 12 MAY 72 JOB NO.: F-72255 P.O. NO.: Y6973
SPECIMEN DESCRIPTION: CIRCUIT BOARD ASSY P/N: 501R327G02 S/N: FN6668
AXIS: Z RUN NO.: 25 ACC. LOCATION: SAMPLE
CUSTOMER: ARINC RESEARCH CORP. ACC. NO.: 2 (RESPONSE)

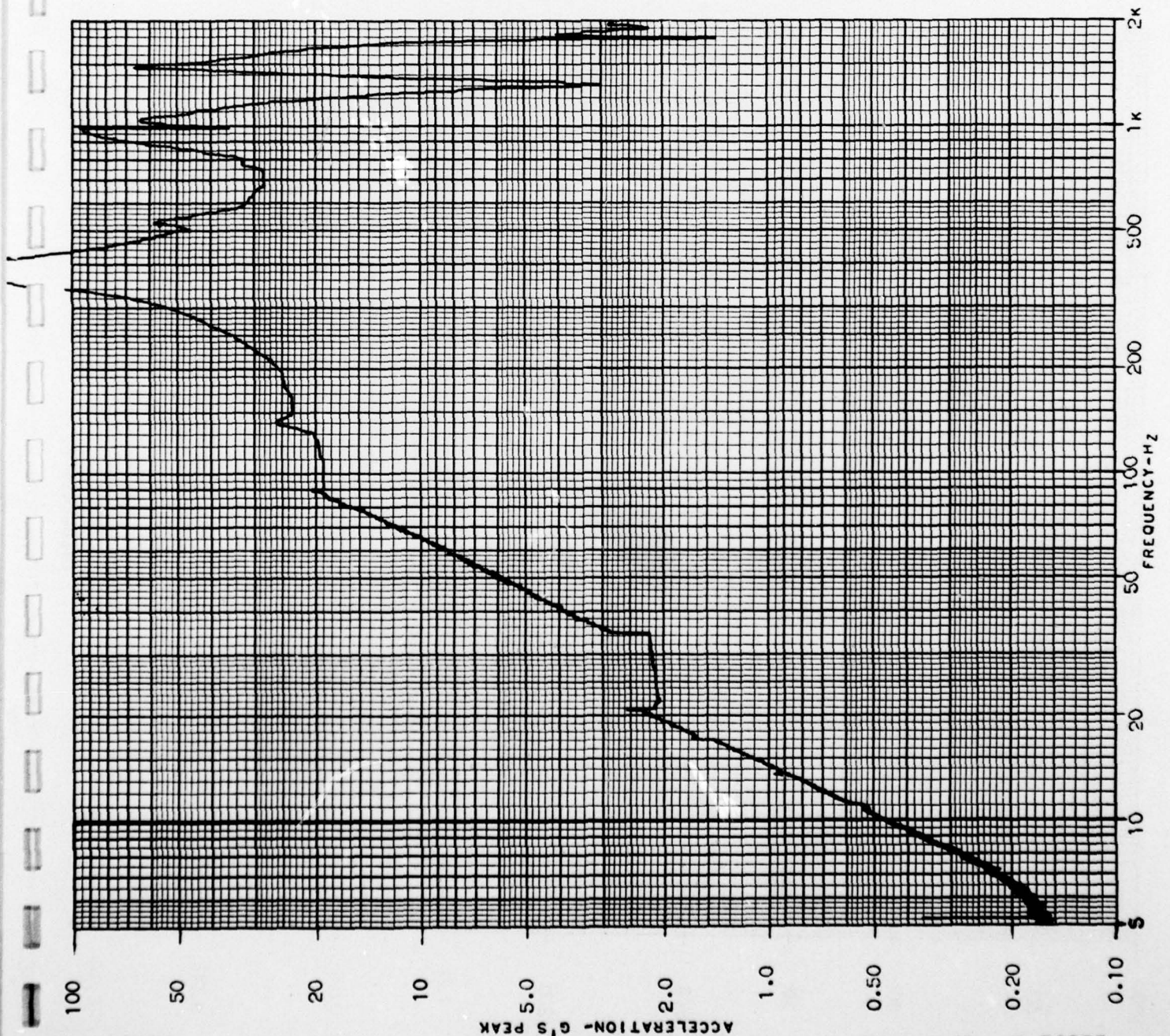

ACCELERATION - G'S PEAK

OGDEN TECHNOLOGY LABORATORIES, INC. (FULLERTON)
VIBRATION TEST DATA
ACCELERATION VS. FREQUENCY

DATE: 12 MAY 72 JOB NO.: F-72255 P.O. NO.: Y6773
SPECIMEN DESCRIPTION: CIRCUIT BOARD ASSY P/N: 501R33603 S/N: FNG313
AXIS: Z RUN NO.: 25 ACC. LOCATION: SAMPLE
CUSTOMER: ARINC RESEARCH CORP. ACC. NO.: 2 (RESPONSE)

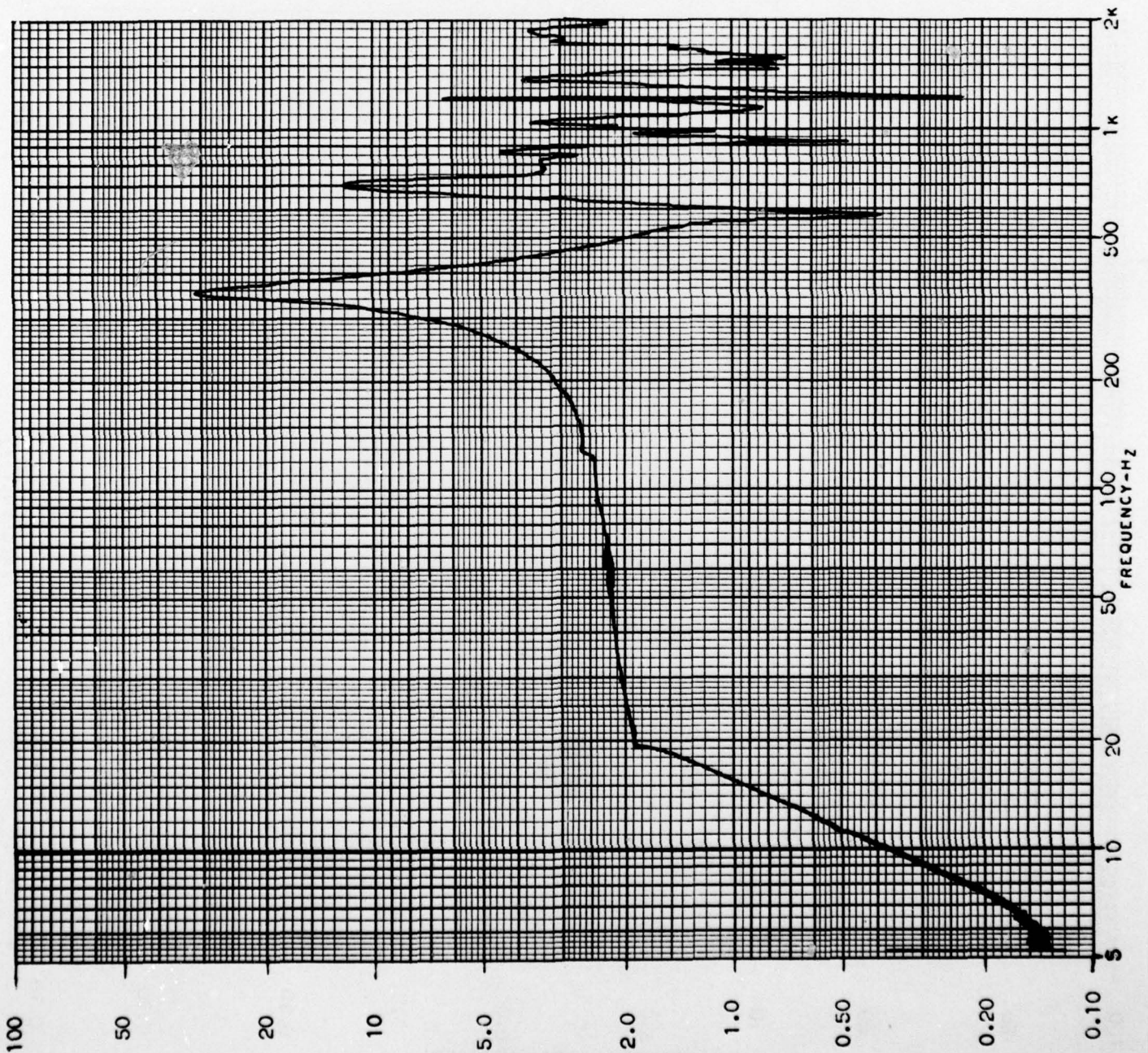

OGDEN TECHNOLOGY LABORATORIES, INC. (FULLERTON)

VIBRATION TEST DATA

ACCELERATION VS. FREQUENCY

DATE: 12 MAY 72 JOB NO.: F-72255 P.O. NO.: Y6973
SPECIMEN DESCRIPTION: CIRCUIT BOARD ASSY P/N: 501R 333603 S/N: FN 6313
AXIS: X RUN NO.: 27 ACC. LOCATION: SAMPLE
CUSTOMER: ARINC RESEARCH CORP. ACC. NO.: 2 (RESPONSE)

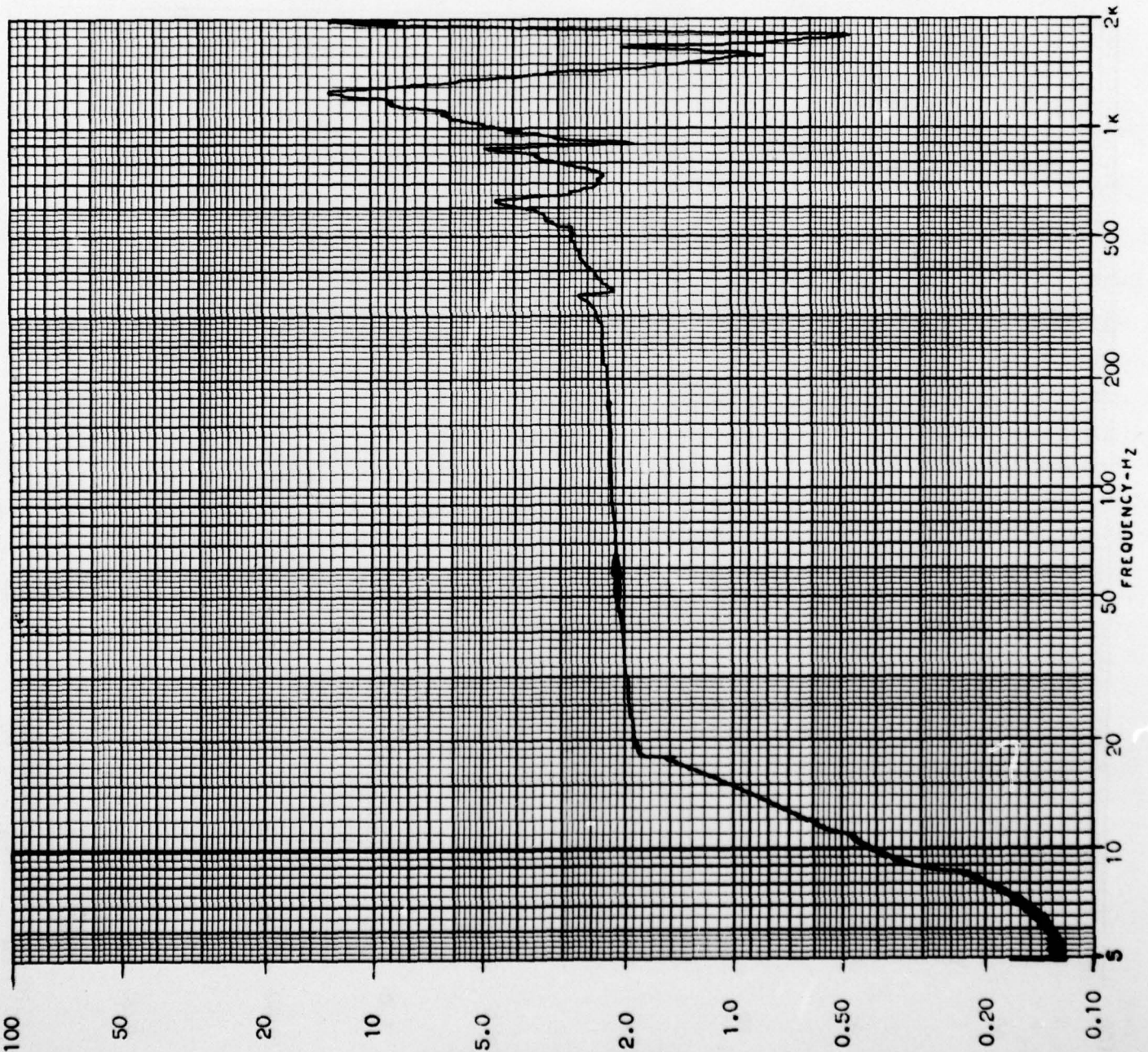

OGDEN TECHNOLOGY LABORATORIES, INC. (FULLERTON)
VIBRATION TEST DATA
ACCELERATION VS. FREQUENCY

DATE: 12 MAY 72 JOB NO.: F-72255 P.O. NO.: Y6973
SPECIMEN DESCRIPTION: CIRCUIT BOARD ASSY P/N: 501R33603 S/N: FN6313
AXIS: Y RUN NO.: 28 ACC. LOCATION: SAMPLE
CUSTOMER: ARINC. RESEARCH CORP. ACC. NO.: 2 (RESPONSE)

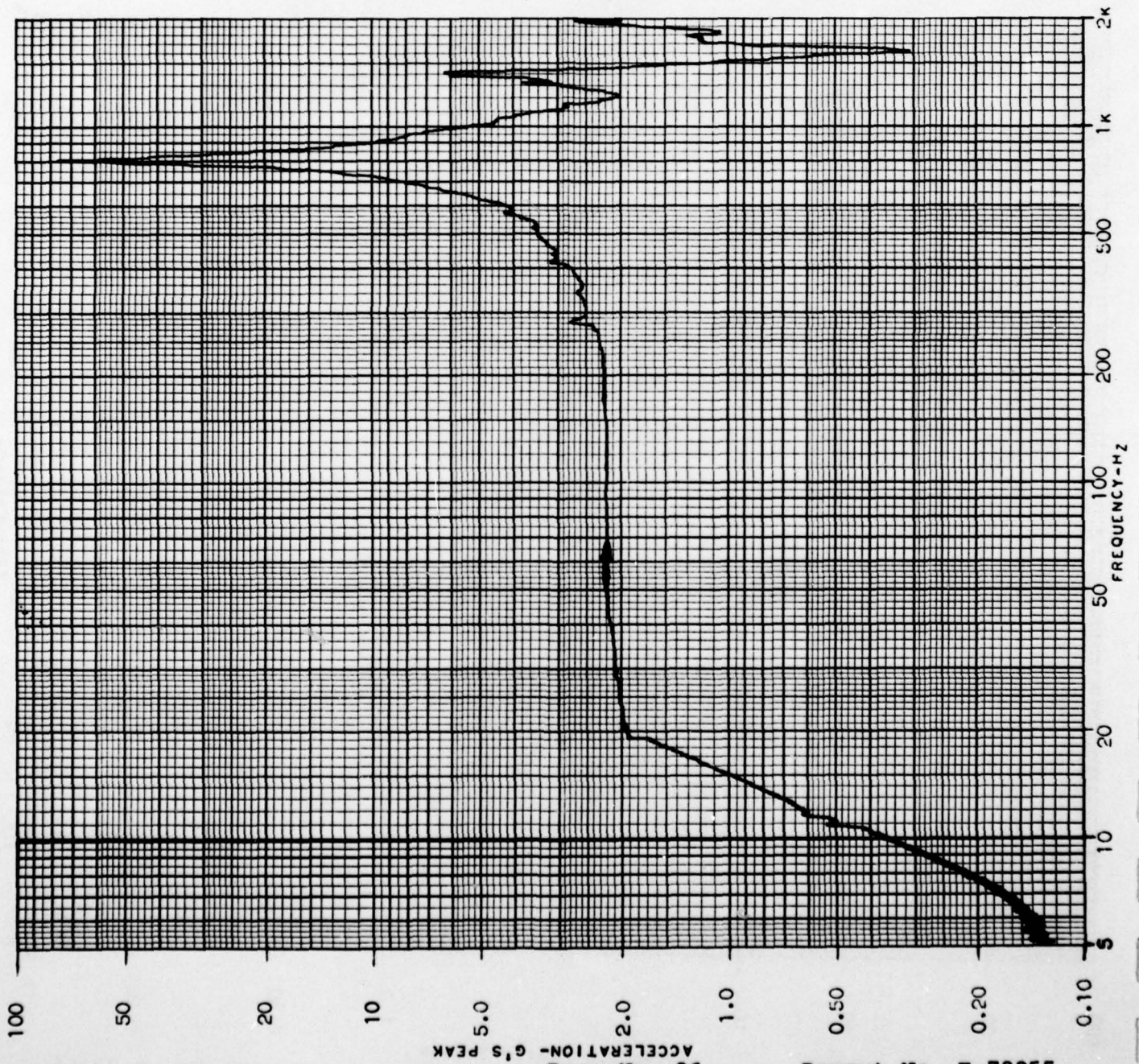

OGDEN TECHNOLOGY LABORATORIES, INC. (FULLERTON)

VIBRATION TEST DATA

ACCELERATION VS. FREQUENCY

DATE: 12 MAY 72 JOB NO.: F-72255 P.O. NO.: Y 6973
SPECIMEN DESCRIPTION: CIRCUIT BOARD ASSY. P/N: 501R333G08 S/N: FN 6313
AXIS: Y RUN NO.: 29 ACC. LOCATION: SAMPLE
CUSTOMER: ARINC RESEARCH CORP. ACC. NO.: 2 (RESPONSE)

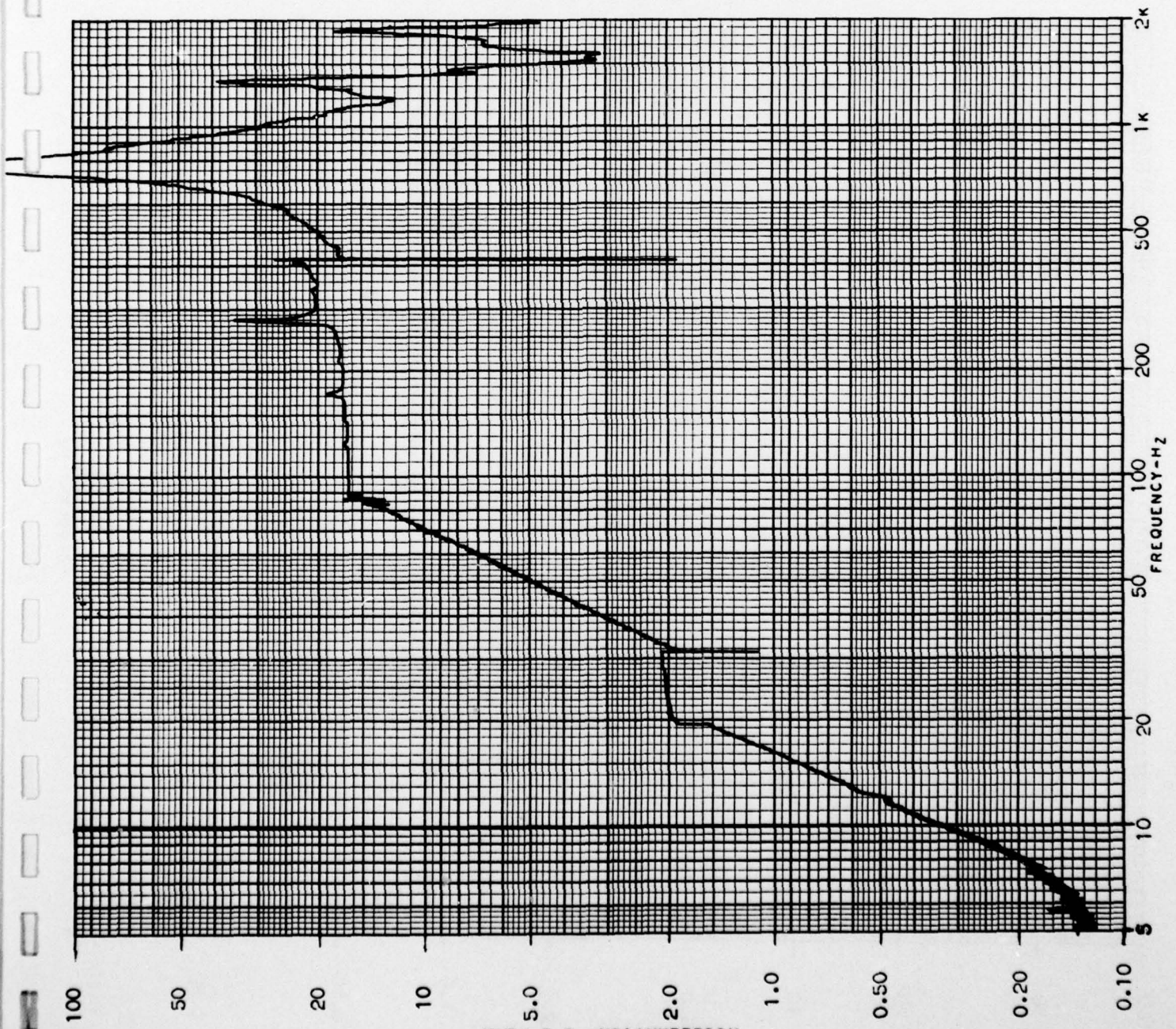

OGDEN TECHNOLOGY LABORATORIES, INC. (FULLERTON)
VIBRATION TEST DATA
ACCELERATION VS. FREQUENCY

DATE: 12 MAY 72	JOB NO.: F-72255	P.O. NO.: Y 6973
SPECIMEN DESCRIPTION: CIRCUIT BOARD ASSY	RUN NO.: 30	P/N: 501R333G03 S/N: FN6313
AXIS: X		ACC. LOCATION: SAMPLE
CUSTOMER: ARINC RESEARCH CORP.		ACC. NO.: 2 (RESPONSE)

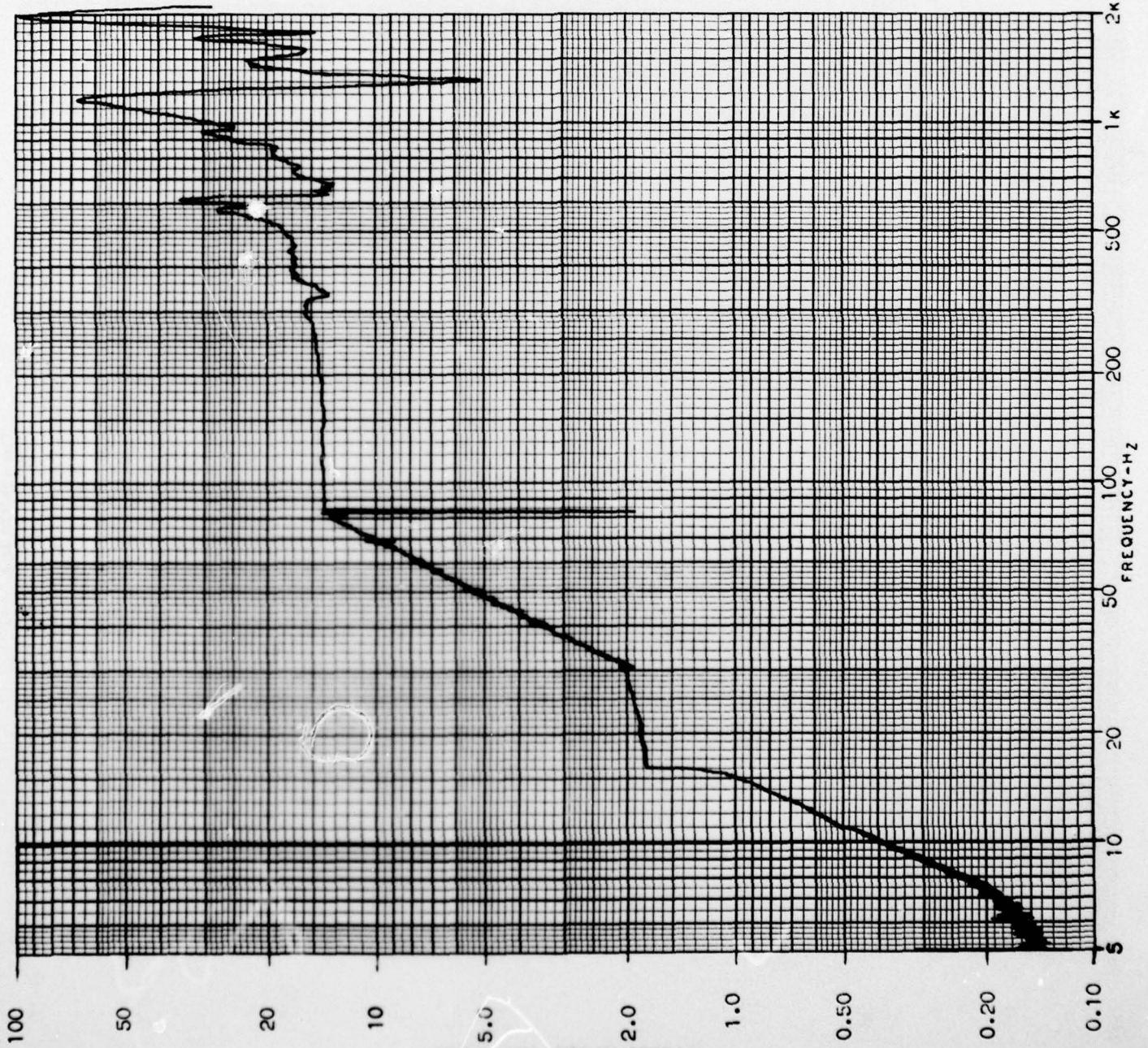

OGDEN TECHNOLOGY LABORATORIES, INC. (FULLERTON)

VIBRATION TEST DATA

ACCELERATION VS. FREQUENCY

DATE: 12 MAY 72 JOB NO.: F-72255 P.O. NO.: Y 6973
SPECIMEN DESCRIPTION: CIRCUIT BOARD ASSY P/N: 501R333603 S/N: FN 6313
AXIS: Z RUN NO.: 31 ACC. LOCATION: SAMPLE
CUSTOMER: ARINC RESEARCH CORP. ACC. NO.: 2 (RESPONSE)

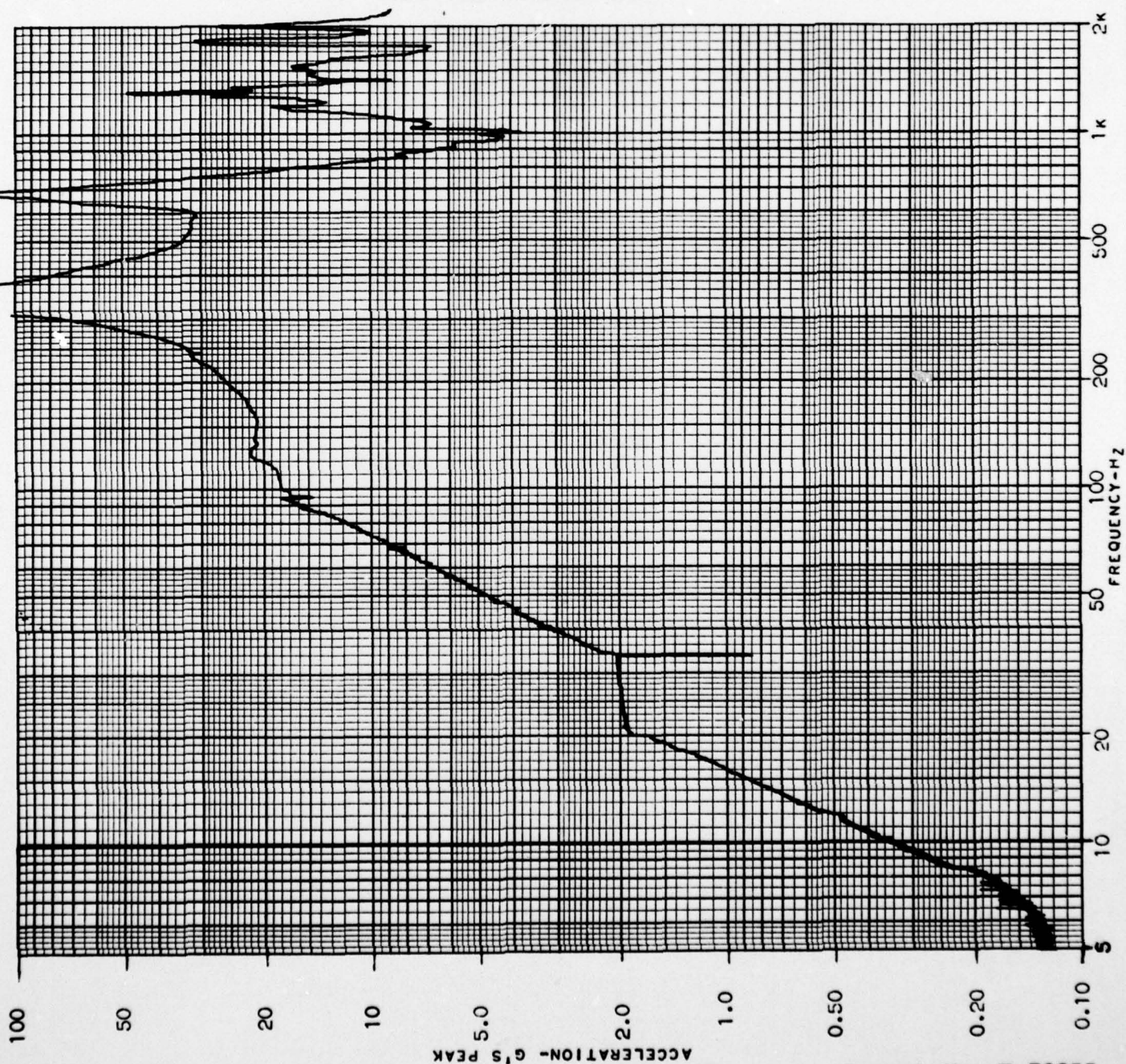

EQUIPMENT LIST

<u>DESCRIPTION</u>	<u>APPARATUS</u>	<u>CALIBRATION</u>
<u>SINE VIBRATION:</u>	Feldmar Stop Watch, OTL Control No. 3119	12 Months Due 9-14-72
	Bruel & Kjaer Automatic Exciter Control, Model 1018, OTL Control No. 153	6 Months Due 10-19-72
	Endevco Accelerometer, Model 2242, OTL Control No. 5696	6 Months Due 9-28-72
	Endevco Amplifier, Model 2614, OTL Control No. 5118	6 Months Due 5-16-72
	Endevco Accelerometer, Model 2226, OTL Control No. 3052	6 Months Due 11-5-72
	Endevco Amplifier, Model 2614, OTL Control No. E-3968	6 Months Due 5-16-72
	X-Y Plotter, Model 2D-2, OTL Control No. 2026	12 Months Due 9-20-72
	Moseley Log Converter, Model 60B, OTL Control No. E-122	6 Months Due 8-28-72
	Power Amplifier, MB Model T995	Not Required
	Vibration Exciter, MB Model C-125	Not Required

UNCLASSIFIED

SECURITY CLASSIFICATION OF THIS PAGE (When Data Entered)

REPORT DOCUMENTATION PAGE		READ INSTRUCTIONS BEFORE COMPLETING FORM
1. REPORT NUMBER C42-01-1-1178	2. GOVT ACCESSION NO.	3. RECIPIENT'S CATALOG NUMBER
4. TITLE (and Subtitle) DESIGN OF PROTOTYPE ASSEMBLIES IN SELECTED LINE REPLACEABLE UNITS OF AN/APQ-109 FCS		5. TYPE OF REPORT & PERIOD COVERED
		6. PERFORMING ORG. REPORT NUMBER C42-01-1-1178
7. AUTHOR(s) K.J. Braman		8. CONTRACT OR GRANT NUMBER(s) F42600-72-D-0779-0002 <i>new</i>
		10. PROGRAM ELEMENT, PROJECT, TASK AREA & WORK UNIT NUMBERS
9. PERFORMING ORGANIZATION NAME AND ADDRESS ARINC Research Corp. 2551 Riva Road Annapolis, Maryland 21401		12. REPORT DATE June 1972
		13. NUMBER OF PAGES 41
11. CONTROLLING OFFICE NAME AND ADDRESS OGDEN AIR MATERIEL AREA Hill Air Force Base, Utah		15. SECURITY CLASS. (of this report) UNCLASSIFIED
		15a. DECLASSIFICATION/DOWNGRADING SCHEDULE
16. DISTRIBUTION STATEMENT (of this Report) UNCLASSIFIED/UNLIMITED		
17. DISTRIBUTION STATEMENT (of the abstract entered in Block 20, if different from Report)		
18. SUPPLEMENTARY NOTES		
19. KEY WORDS (Continue on reverse side if necessary and identify by block number)		
20. ABSTRACT (Continue on reverse side if necessary and identify by block number)		