

AD-A052 589

OHIO STATE UNIV COLUMBUS ELECTROSCIENCE LAB  
ADAPTIVE ARRAYS FOR AM AND FM SIGNALS.(U)  
FEB 78 R T COMPTON  
ESL-4618-4

F/G 17/2

UNCLASSIFIED

N00019-77-C-0156  
NL

| OF |  
ADA  
062 589



END  
DATE  
FILMED  
5-78  
DDC

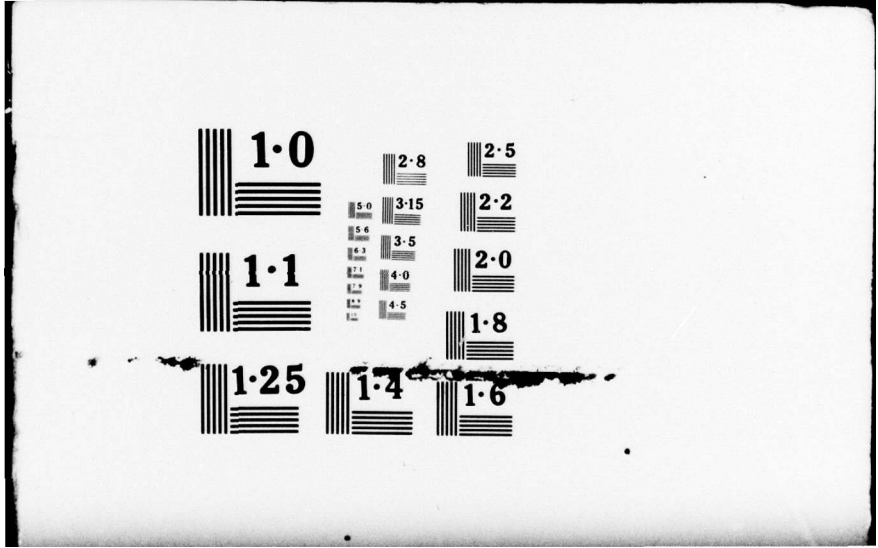

AD A 052589



*R*

OFFERED FOR PUBLIC RELEASE  
DISTRIBUTION UNLIMITED

*(12)*

ADAPTIVE ARRAYS FOR AM AND FM SIGNALS

R.T. Compton, Jr.

The Ohio State University

# ElectroScience Laboratory

Department of Electrical Engineering  
Columbus, Ohio 43212

DDDC  
APR 4 1978  
TV 5  
F  
*R*

AD No. **DDC FILE COPY**

Quarterly Report 784618 (4618-4)

February 1978

Contract N00019-77-C-0156

Department of the Navy  
Naval Air Systems Command  
Washington, D.C. 20361

## NOTICES

When Government drawings, specifications, or other data are used for any purpose other than in connection with a definitely related Government procurement operation, the United States Government thereby incurs no responsibility nor any obligation whatsoever, and the fact that the Government may have formulated, furnished, or in any way supplied the said drawings, specifications, or other data, is not to be regarded by implication or otherwise as in any manner licensing the holder or any other person or corporation, or conveying any rights or permission to manufacture, use, or sell any patented invention that may in any way be related thereto.

9 Quarterly rept. 1 Jun - 31 Aug 77,

UNCLASSIFIED

SECURITY CLASSIFICATION OF THIS PAGE (When Data Entered)

REPORT DOCUMENTATION PAGE		READ INSTRUCTIONS BEFORE COMPLETING FORM
1. REPORT NUMBER	2. GOVT ACCESSION NO.	3. RECIPIENT'S CATALOG NUMBER (14) ESL-4618-4
4. TITLE (and Subtitle) 6 ADAPTIVE ARRAYS FOR AM AND FM SIGNALS.		5. TYPE OF REPORT & PERIOD COVERED Quarterly Report 6/1/77 - 8/31/77
7. AUTHOR(s) 10 R.T./Compton, Jr.		6. PERFORMING ORG. REPORT NUMBER 784618 (4618-4)
9. PERFORMING ORGANIZATION NAME AND ADDRESS The Ohio State University ElectroScience Laboratory, Department of Electrical Engineering, Columbus, Ohio 43212		8. CONTRACT OR GRANT NUMBER(s) 15 Contract N00019-77-C-0156
11. CONTROLLING OFFICE NAME AND ADDRESS Department of the Navy Naval Air Systems Command Washington, D.C. 20361		10. PROGRAM ELEMENT, PROJECT, TASK AREA & WORK UNIT NUMBERS Project #N00019-77-C-PR-RJ004
14. MONITORING AGENCY NAME & ADDRESS (if different from Controlling Office) 11 Feb 78 12 7p.		12. REPORT DATE February 1978
		13. NUMBER OF PAGES 4
		15. SECURITY CLASS. (of this report) Unclassified
		15a. DECLASSIFICATION/DOWNGRADING SCHEDULE
16. DISTRIBUTION STATEMENT (of this Report)  APPROVED FOR PUBLIC RELEASE: DISTRIBUTION UNLIMITED		
17. DISTRIBUTION STATEMENT (of the abstract entered in Block 20, if different from Report)  APPROVED FOR PUBLIC RELEASE: DISTRIBUTION UNLIMITED		
18. SUPPLEMENTARY NOTES		
19. KEY WORDS (Continue on reverse side if necessary and identify by block number) Adaptive Arrays Interference Rejection Communications		
20. ABSTRACT (Continue on reverse side if necessary and identify by block number)  This report describes progress under Naval Air Systems Command Contract N00019-77-C-0156 during the third quarterly period. Research on the problem of integrating adaptive arrays into conventional modulation systems is summarized.		

402251 B

TABLE OF CONTENTS

	Page
INTRODUCTION	1
PROGRESS	1
A. Implementation of the AM System	1
B. Studies on Single Sideband Tagging	3
PLANS FOR NEXT QUARTER	3
REFERENCES	4

ACCESSION for	
File Section	<input checked="" type="checkbox"/>
Buff Section	<input type="checkbox"/>
REMARKS	<input type="checkbox"/>
DISTRIBUTION/AVAILABILITY CODES	
A	

## INTRODUCTION

This report describes progress under NASC Contract N00019-77-C-0156 during the third quarterly period. There are three areas of work under this contract. The first involves experimental tests of an adaptive array in an AM communication system. The second involves array experiments with an FM communication system. The third consists of theoretical studies of methods of integrating adaptive arrays into other types of conventional communication systems.

The AM and FM communication systems involve the addition of a binary phase switching modulation on conventional AM and FM signals. The purpose of this phase switching is to allow the array to distinguish between the desired signal and interference. Implementation of the system with this phase switching requires an IF delay lock loop for the AM system and a Costas loop and baseband delay lock loop for the FM system, in addition to other minor circuitry.

## PROGRESS

During the third quarter of this program, most of the work has involved the implementation of the AM system, as described below. A small amount of time has also been devoted to the problem of tagging single sideband signals in adaptive arrays.

### A. Implementation of the AM System

Construction of a brassboard version of the coded AM reference signal generation circuitry is currently underway. The details of the circuits used were described in the second Quarterly Report[1]. A few minor changes have been made in the design, however, to improve performance. The most significant change was to the 1 kHz active bandpass filter design. For the filter design previously shown (Figure 2 of Report 4618-3), it was found to be difficult to obtain identical filter characteristics in the two channels required in the delay lock loop. That design did not have sufficient adjustment flexibility to enable the two channels to be matched properly. Instead we have substituted the filter design shown in Figure 1, for which center frequency, Q, and passband gain can all be separately varied.

At the end of the quarterly period, the brassboard version of the delay lock loop has been partially constructed. Construction will be completed during the fourth quarter.

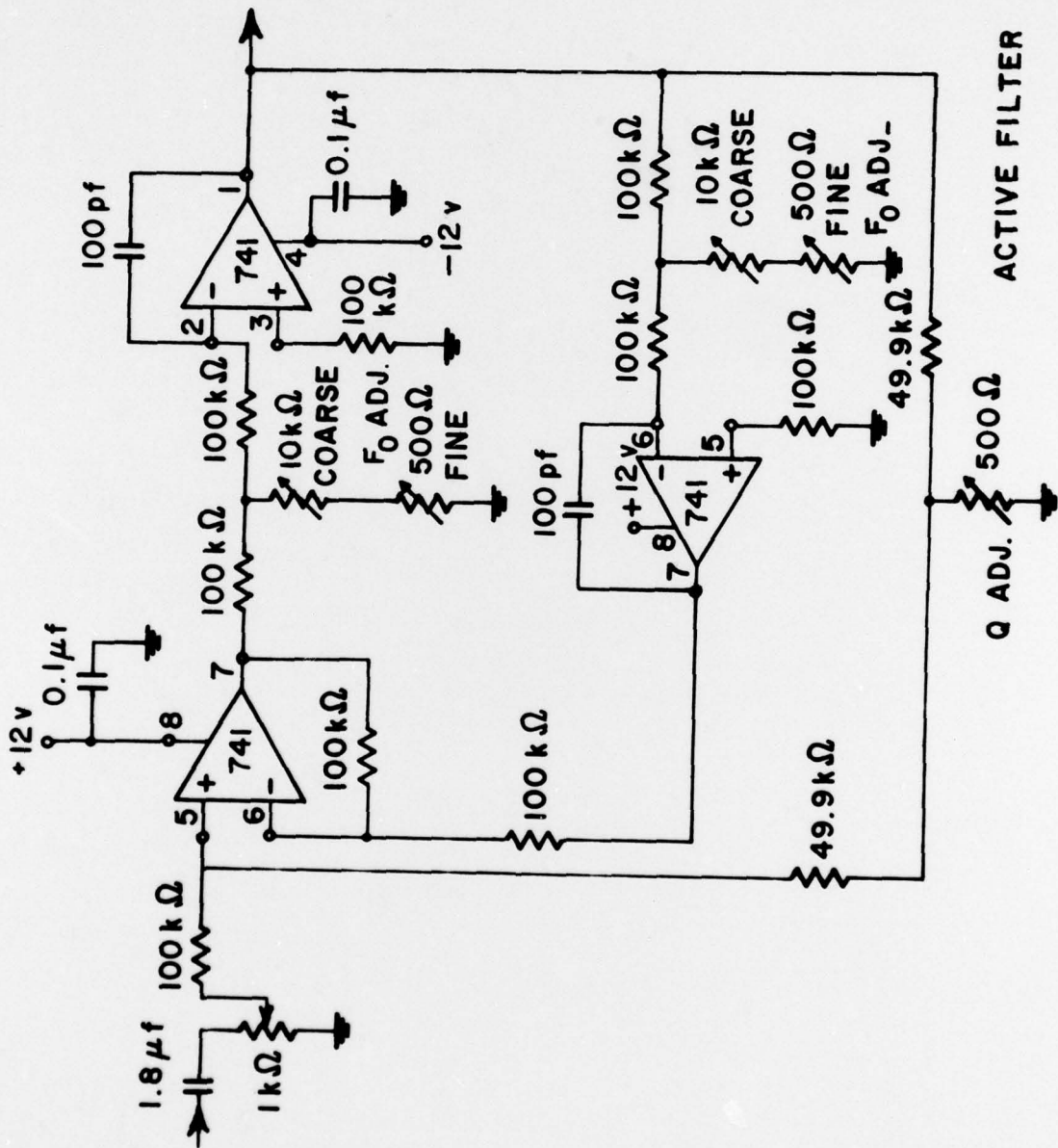

Figure 1. 1 kHz active bandpass filter.

## B. Studies on Single Sideband Tagging

Studies on desired signal tagging and reference signal generation methods for single sideband signals have been started. The methods under study include the use of two-frequency tone modulation and pseudo-noise code modulation. Either of these modulations may be imposed in the form of product modulation or may be linearly added to the transmitted signal. The effect of such modulation on the correlation between the reference signal and interference is being evaluated.

### PLANS FOR NEXT QUARTER

During the next quarter we plan to finish construction of the brassboard delay lock loop model for the AM system and to begin testing the performance of the adaptive array with phase-switched AM. Also, circuit design for phase-switched FM will be started. Finally, studies of tagging methods for single sideband will be continued.

REFERENCES

1. Compton, R.T., Jr., "Adaptive Arrays for AM and FM Signals," Quarterly Report 4618-3, June 1977, The Ohio State University ElectroScience Laboratory, Department of Electrical Engineering; prepared under Contract N00019-77-C-0156 for Naval Air Systems Command.