

AD-A052 603

HYDROLOGIC ENGINEERING CENTER DAVIS CALIF
PROCEEDINGS OF A SEMINAR ON COMPUTER APPLICATIONS IN HYDROLOGY --ETC(U)
FEB 71 L R BEARD, D R BURNETT, R E BENNION

F/G 8/8
--ETC(U)

UNCLASSIFIED

HEC-SP-04

NL

1 of 3
AD
A052603

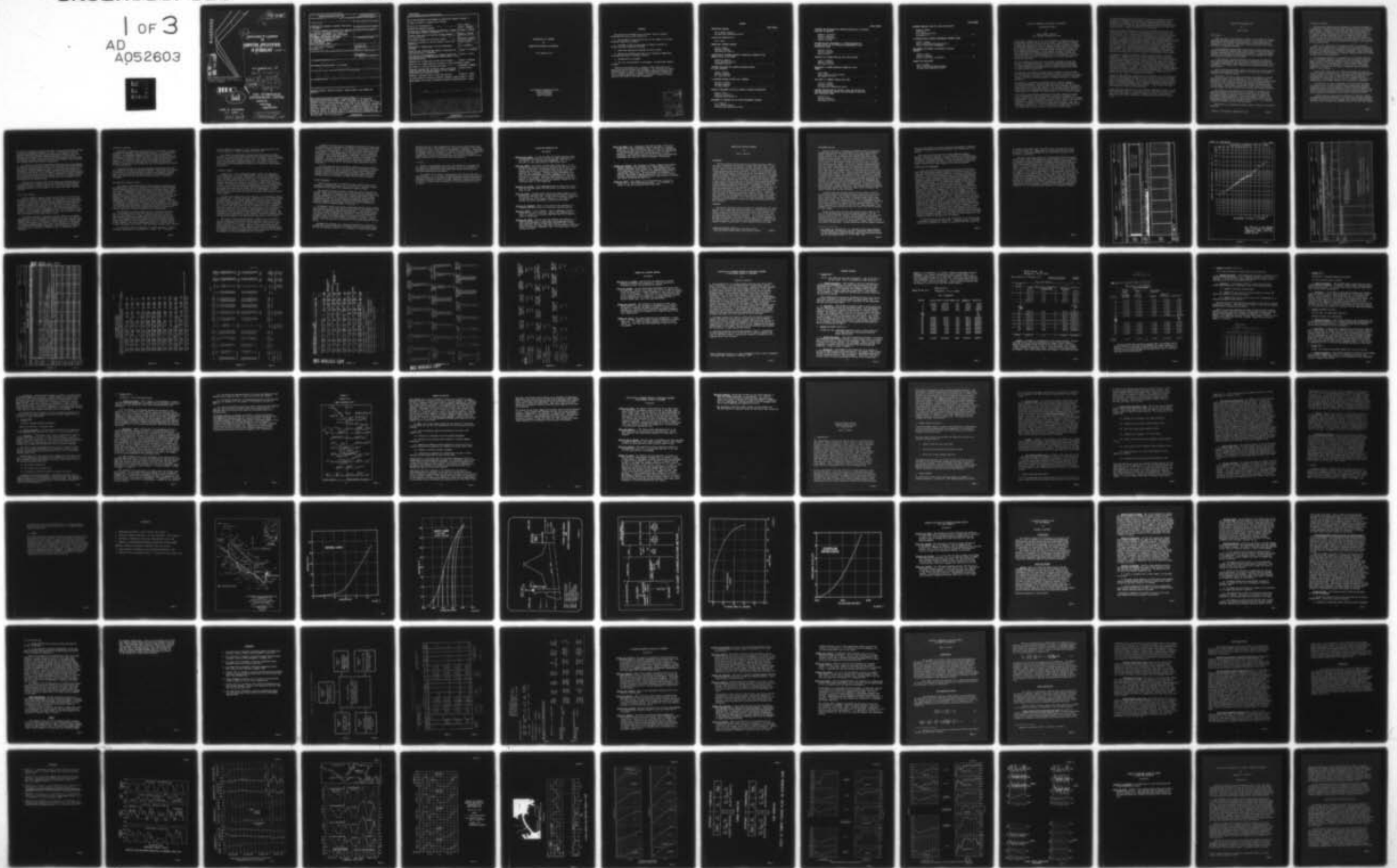

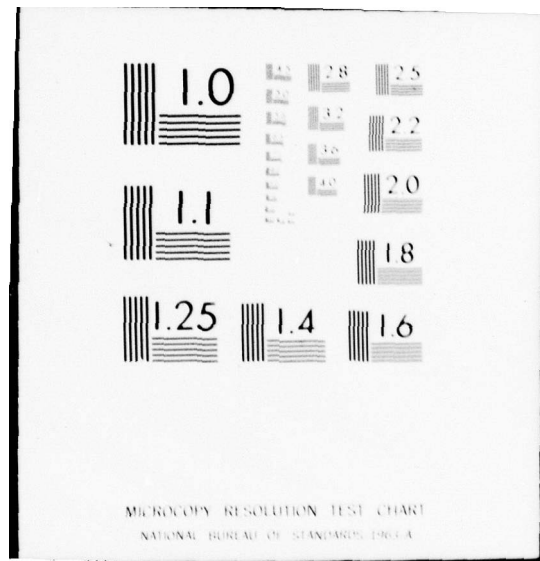

MICROCOPY RESOLUTION TEST CHART
NATIONAL BUREAU OF STANDARDS-1963-A

AD A 052603

14
HEC-SP-04

12
SC

6
PROCEEDINGS OF A SEMINAR
ON
COMPUTER APPLICATIONS
IN HYDROLOGY Held on

23-25 FEBRUARY 1971, at
Davis, California,

AD No. DDC FILE COPY

Leo R./Beard, Dale R./Burnett,
Richard E./Bennion, Jerry L./Curnutt
William G./Westall

11 Feb 71

12 220p.

DDC
RECEIVED
APR 13 1978
A

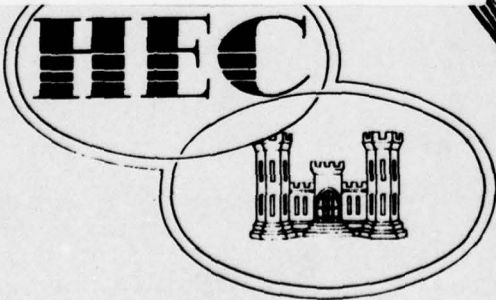

THE HYDROLOGIC
ENGINEERING CENTER

- research
- training
- application

CORPS OF ENGINEERS
U. S. ARMY 142

407989

DISTRIBUTION STATEMENT A

Approved for public release
Distribution Unlimited

4B

SECURITY CLASSIFICATION OF THIS PAGE (When Data Entered)

REPORT DOCUMENTATION PAGE		READ INSTRUCTIONS BEFORE COMPLETING FORM
1. REPORT NUMBER	2. GOVT ACCESSION NO.	3. RECIPIENT'S CATALOG NUMBER
4. TITLE (and Subtitle) Proceedings of a Seminar on Computer Applications in Hydrology		5. TYPE OF REPORT & PERIOD COVERED
7. AUTHOR(s) L.R. Beard, D.R. Burnett, R.E. Bennion, J.L. Curnutt, W.G. Westall, J.T. Price, A.J. Fredrich, E.A. Cristofano, H.D. Pierce, J.A. Matthews, S. Copper, W.A. Thomas, R. Mirick, D.M. Thomas, R.L. Renner, W.L. Sharp		6. PERFORMING ORG. REPORT NUMBER
9. PERFORMING ORGANIZATION NAME AND ADDRESS The Hydrologic Engineering Center U.S. Army Corps of Engineers 609 Second Street Davis, California 95616		8. CONTRACT OR GRANT NUMBER(s)
11. CONTROLLING OFFICE NAME AND ADDRESS U.S. Army Corps of Engineers Washington, D.C.		10. PROGRAM ELEMENT, PROJECT, TASK AREA & WORK UNIT NUMBERS
14. MONITORING AGENCY NAME & ADDRESS (if different from Controlling Office)		12. REPORT DATE February 1971
		13. NUMBER OF PAGES 214
		15. SECURITY CLASS. (of this report) Unclassified
		15a. DECLASSIFICATION/DOWNGRADING SCHEDULE
16. DISTRIBUTION STATEMENT (of this Report) Distribution of this document is unlimited.		
17. DISTRIBUTION STATEMENT (of the abstract entered in Block 20, if different from Report)		
18. SUPPLEMENTARY NOTES		
19. KEY WORDS (Continue on reverse side if necessary and identify by block number) Computer programs, hydrologic aspects, computer models, data storage and retrieval		
20. ABSTRACT (Continue on reverse side if necessary and identify by block number) These seminar proceedings contain 16 papers presented at The Hydrologic Engineering Center 23-25 February, 1971. The purpose of the seminar was to provide a forum for sharing experiences and views on such subjects as: a) case studies of unique applications of the computer for solving hydrologic engineering problems b) critiques of past use and misuse of computer programs for solving hydrologic engineering problems c) areas where generalized programs are sorely needed d) methods for managing input data or for analyzing, summarizing, and presenting results of computer analysis e) documentation of programs f) the		

UNCLASSIFIED

SECURITY CLASSIFICATION OF THIS PAGE(When Data Entered)

role and philosophy of development of generalized computer programs.

Titles and authors of papers are as follows:

Closing the Technology Gap	Leo R. Beard
Generalized Computer Programs	Dale R. Burnett
Application of Computer Programs to Hydrologic Problems of the Central Valley of California	Richard E. Bennion
Computer Application for Interior Drainage Studies - St. Louis District	Jerry L. Cumutt
A Backwater Program for the GE-225 Computer	William G. Westall
Hydraulic Transients in the TVA System of Rivers and Reservoirs	James T. Price
Management of Computer Use in Solving Engineering Problems	A. J. Fredrich
Combining New Techniques and Computer Technologies for Problem Solutions in Hydrology	Eugene A. Cristofano
The Need for and Development of a Computer Program for Re-Establishing Low Flow Navigation Requirements on the Apalachicola River	Herlon D. Pierce
Computer Use in Regulating the Ohio River Projects	James S. Matthews
Regulation of Complex Reservoir Systems for Flood Control	Saul Cooper
The Power of a General-Storage Data Array	William A. Thomas
Computer Programs Used to Collect, Store, and Analyze Data Received from the New England Division Automatic Hydrologic Radio Reporting System	Robert Mirick
Computer Techniques Used in a Mass Data Analysis	Donald M. Thomas
A Conversationally-Oriented Engineering Computer System	Robert L. Renner
Requirements for review of Engineering Computer Programs	Warren L. Sharp

Computer programs, hydrologic aspects, computer models, data storage and retrieval

These seminar proceedings contain 18 papers presented at the Hydrologic Engineering Center 23-25 February, 1971. The purpose of the seminar was to provide a forum for sharing experiences and views on such subjects as: (a) case studies of unique applications of the computer for solving hydrologic engineering problems; (b) critiques of past use and misuse of computer programs for solving hydrologic engineering problems; (c) areas where generalized programs are sorely needed; (d) methods for managing input data or for analyzing, summarizing, and presenting results of computer analysis; (e) documentation of programs; (f) the

UNCLASSIFIED

UNCLASSIFIED

SECURITY CLASSIFICATION OF THIS PAGE(When Data Entered)

PROCEEDINGS OF A SEMINAR
ON
COMPUTER APPLICATIONS IN HYDROLOGY

23-25 February 1971

The Hydrologic Engineering Center
Corps of Engineers
609 Second Street
Davis, California

FOREWORD

The purpose of the seminar was to provide a forum for sharing experiences and views on such subjects as:

- a. Case studies of unique applications of the computer for solving hydrologic engineering problems.
- b. Critiques of past use and misuse of computer programs for solving hydrologic engineering problems.
- c. Areas where generalized programs are sorely needed.
- d. Methods for managing input data or for analyzing, summarizing, and presenting results of computer analyses.
- e. Documentation of programs.
- f. The role, and philosophy of development, of generalized computer programs.

Papers and discussions are, in general, frank evaluations by the authors and are not official Corps documents. The views and conclusions expressed herein are those of the individual seminar participants, and are not intended to modify or replace official guidance or directives such as Engineer Regulations, Manuals, Circulars, or Technical Letters issued by the Office of the Chief of Engineers.

ADDRESS FOR	White Section	<input checked="" type="checkbox"/>
WTIS	Buff Section	<input type="checkbox"/>
DOC		<input type="checkbox"/>
UNCLASSIFIED		
JUSTIFICATION		
BY		
RESTRICTION/AVAILABILITY CODE		
SIG.	AVAIL. CODE/SPECIAL	

A

CONTENTS

	PAPER NUMBER
INTRODUCTORY REMARKS	
Leo R. Beard, Director The Hydrologic Engineering Center	
CLOSING THE TECHNOLOGY GAP	
Leo R. Beard	1
GENERALIZED COMPUTER PROGRAMS	
Dale R. Burnett Hydraulic Engineer San Francisco District	2
APPLICATION OF COMPUTER PROGRAMS TO HYDROLOGIC PROBLEMS OF THE CENTRAL VALLEY OF CALIFORNIA	
Richard E. Bennion Chief, Hydrology Section Sacramento District	3
COMPUTER APPLICATION FOR INTERIOR DRAINAGE STUDIES - ST. LOUIS DISTRICT	
Jerry L. Curnutt Hydraulic Engineer St. Louis District	4
A BACKWATER PROGRAM FOR THE GE-225 COMPUTER	
William G. Westall Hydraulic Engineer St. Paul District	5
HYDRAULIC TRANSIENTS IN THE TVA SYSTEM OF RIVERS AND RESERVOIRS	
James T. Price Hydraulic Specialist Tennessee Valley Authority	6
MANAGEMENT OF COMPUTER USE IN SOLVING ENGINEERING PROBLEMS	
A. J. Fredrich Chief, Research Branch The Hydrologic Engineering Center	7

PAPER NUMBERS

COMBINING NEW TECHNIQUES AND COMPUTER TECHNOLOGIES FOR PROBLEM SOLUTIONS IN HYDROLOGY

Eugene A. Cristofano
Hydraulic Engineer
Bureau of Reclamation
Denver, Colorado 8

THE NEED FOR AND DEVELOPMENT OF A COMPUTER PROGRAM FOR RE-ESTABLISHING LOW FLOW NAVIGATION REQUIREMENTS ON THE APALACHICOLA RIVER

Herlon D. Pierce
Hydraulic Engineer
Mobile District 9

COMPUTER USE IN REGULATING THE OHIO RIVER PROJECTS

James S. Matthews
Hydraulic Engineer
Ohio River Division 10

REGULATION OF COMPLEX RESERVOIR SYSTEMS FOR FLOOD CONTROL

Saul Cooper
Chief, Reservoir Control Center
New England Division 11

THE POWER OF A GENERAL-STORAGE DATA ARRAY

William A. Thomas
Hydraulic Engineer
The Hydrologic Engineering Center 12

COMPUTER PROGRAMS USED TO COLLECT, STORE, AND ANALYZE DATA RECEIVED FROM THE NEW ENGLAND DIVISION AUTOMATIC HYDROLOGIC RADIO REPORTING SYSTEM

Robert Mirick
Hydraulic Engineer
New England Division 13

COMPUTER TECHNIQUES USED IN A MASS DATA ANALYSIS

Donald M. Thomas
Hydrologist
U. S. Geological Survey
Washington, D. C. 14

A CONVERSATIONALLY-ORIENTED ENGINEERING COMPUTER SYSTEM

Robert L. Renner
Chief, Research and Training Section
Office of the Chief of Engineers 15

REQUIREMENTS FOR REVIEW OF ENGINEERING COMPUTER PROGRAMS

Warren L. Sharp
Hydraulic Engineer
Office of the Chief of Engineers 16

SUMMARY AND CONCLUSIONS

Bill S. Eichert
Chief, Training and Methods Branch
The Hydrologic Engineering Center

SEMINAR ON COMPUTER APPLICATIONS IN HYDROLOGY

INTRODUCTORY REMARKS

by

LEO R. BEARD, Director
The Hydrologic Engineering Center

I would like to welcome all of you to The Hydrologic Engineering Center, to the Sacramento District and to the city of Davis. This seminar is somewhat different from previous seminars that have concentrated on particular areas of hydrologic engineering. In those seminars, we were interested in defining the hydrologic problems that exist, the current methods used in their solutions, and the outlook for improved application of computer techniques and new mathematical developments. In this seminar, we hope to discuss the state of development of computer applications in hydrologic engineering, the problems that are being encountered in the use of computers, and future trends that can be expected in the application of computer technology to hydrologic engineering.

Very few engineers will deny that the electronic computer has come into its own in the engineering field. Almost every engineering organization is becoming dependent on computers, because computers have provided means of solving problems more economically or for solving problems that cannot be solved feasibly in other ways.

Ten years ago, the computer was used almost exclusively to solve problems of relatively minor scope that could be done by hand in a few hours or less. Recently, however, the computer is used to perform long chains of computations without interruption, and the complexity of computer programs has increased enormously.

Ten years ago, the engineer communicated with the computer through a professional programmer. Today, software packages such as FORTRAN have been developed to such a level that, with very little training, the engineer communicates directly with the computer. Time sharing on large computers has reduced many of the programming constraints and has provided the rapid turn-around needed by an engineer for really effective use of electronic computers.

The efficiency and unequalled capability of electronic computers now makes their use imperative. The ever-increasing complexity of problems to be solved provides a pressing challenge to expand program capability and computer applications. Computer programs are growing in size. There is ever-increasing requirement to upgrade their capability and their efficiency. Thus, the computer is threatening to become an uncontrollable juggernaut that carries the engineer along with it. We are now reaching the stage where control of this machine and its future course of action is of primary concern.

As computer programs become more complex, it becomes increasingly difficult to check their validity, and continuous correcting and revision of large programs is a necessity. As they are used, then, difficulties may be encountered in new applications, and it might be weeks before such difficulties can be overcome. Is this an inevitable consequence of greater program complexity, or is it possible to avoid this by some means?

Except for compiling languages and some basic mathematical operations, new programs are generally written by each organization for each general type of application. This is because it is relatively easy to write some programs, and it is difficult to become thoroughly acquainted with programs written by others. In order to overcome this, many institutions have established libraries of programs that are usable generally, or of problem-oriented languages whereby a combination of preprogrammed routines can be selected to solve any problem. Suffice it to say that, as of now, neither of these approaches has been successful in serving the real needs at the planning and design level in the field. Perhaps there is need for developing a systematic manner of programming, including standard means of subscripting, variable naming, and so forth. Also, there is a need for better documentation than has been available, and this subject will be discussed to some extent in this seminar.

Differences in hardware availability create many difficulties in computer applications. Computers with small memories greatly restrict programming capability and greatly increase the cost of programming. It is only economical to develop large programs in a large computer, and these must often be segmented for use in smaller computers. The amount of work involved in adapting programs to several different computers can exceed the original cost of developing the program and, in a sense, is largely wasted effort if satisfactory alternative hardware is available. Software differences among various computers also increase problems associated with computer applications. In this regard, however, it is often possible to anticipate software differences, and to program in such a way as to minimize their effects.

Despite the many problems associated with the effective use of the electronic computer in hydrologic engineering, benefits obtained to date and the future value of past development far exceed the cost and justify the time and effort devoted to those developments. We are here to discuss some of these developments, but primarily to propose means of managing computer applications in the future so as to increase benefits most rapidly. I hope that you will keep this in mind as you make your presentations.

I hope also that, while you are at The Hydrologic Engineering Center, you will become acquainted with all of our people and our facilities and that you will feel free in the future to contact us whenever we can be of assistance or whenever you have ideas, suggestions or information that would be of value to us.

CLOSING THE TECHNOLOGY GAP

By

Leo R. Beard¹

The Problem . . .

Every few years, a new dimension is added to the problems of planning, designing and operating water resource projects. Thirty years ago, most Corps projects were designed and operated for a single purpose such as navigation or flood control. Even then, associated problems were complex and often not adequately solvable.

As multipurpose projects became practical and a general necessity, the number of alternative possibilities in each planning or operation decision increased exponentially with the number of purposes. It took deep understanding, wide experience and great ingenuity for the engineers to obtain even acceptable solutions to the problems.

In the meantime, a growing awareness of the necessity to integrate water resources development into the political process dictated the need to examine alternatives to each project and to many design features of each alternative, thus adding another dimension that expanded the problem area significantly.

Next, increasing development within a river basin or a region required the functional integration of many projects, and this added yet another dimension to the analysis process.

Furthermore, not only is there an increase in the number of problems that must be studied, but the complexity of each individual problem is magnified with each added dimension because of the interaction among problems. Fortunately, legal, physical, economic and political constraints often rule out much of the problem area and thus simplify the planning process to some extent. Nevertheless, the problems at this stage are admittedly far more complex than can successfully be attacked with present technology.

The entrance of water quality (and its myriads of parameters) as a dominating influence on water resources development is now increasing political pressures to the point that the water resources problem area will again be greatly expanded. It will be necessary to examine alternatives that have heretofore been politically infeasible and to evaluate environmental effects that are far more complex than any of the phenomena heretofore considered in water resources studies.

Thus there is an expanding gap between problem complexity and technical capability.

¹Director, The Hydrologic Engineering Center

Attacking the Problem . . .

The electronic computer and new mathematical techniques developed as a consequence of computer capability offer the best promise of closing this technology gap. Yet there is a disturbing lag between the origin of new ideas, concepts, techniques or tools and their effective employment in the planning, design and operation of water resource projects. There is no question that the development process of converting a theoretical concept to a practical tool takes time. Yet there is surely a factor of 2 to 10 between the time that the process actually takes and what it would take if execution of the process were perfectly efficient. This difference is due to many factors.

First of all, ideas must be critically reviewed in the academic community, and a consensus must be transmitted to the practicing engineer. This takes time because of the complexity of many theoretical concepts and because of the competing flow of technical information. These difficulties are compounded by the differences in technical language between the academic community and the design community.

The development process is a responsibility of the design community, not of the academic community, because it is not practical to convey the degree of detail required for adequate design to the academic community, except perhaps in a few selected cases. But the design community is reluctant to carry the ball because it is difficult for a busy design organization to devote time and effort to ideas that have no immediate impact on current design.

This is often interpreted as a stubborn reluctance to discard old familiar methods and adopt new ones. There is certainly some justification in this inference, but there is also good reason not to adopt unproven techniques that could result in hazard to life or general welfare. Consequently, a significant part of the lag is consumed in the process of demonstrating to the design community that a technique is dependable.

Six years ago, the Corps of Engineers took steps toward narrowing the technical gap in a major technical area by creating The Hydrologic Engineering Center, with the missions of research, methods development, training and special projects assistance to all Corps field offices. The Center was directed to maintain close liaison with major universities and other development organizations as well as with Corps field offices.

Through training courses and the combination of research, methods systemization and special assistance, the Center has encouraged hydrologic engineers throughout the Corps to consider and evaluate newly developing techniques and to recognize the tremendous power of the electronic computer.

The HEC has provided more than 2000 man-weeks of group and individual training to hydrologic engineers throughout the Corps. This training is directly oriented toward providing the technical background necessary to solve the hydrologic engineering problems commonly encountered in Corps offices. Nevertheless, it appears that training alone cannot wholly satisfy the needs for providing technical capability to solve the increasingly complex problems that comprise modern water resources engineering.

The training in fundamental engineering methodology must be supplemented by assistance in applying the methods to the distinctive and diverse problems that confront engineers engaged in analysis of virtually every type of water management or water development project. Although specialized assistance on a specific problem can be of considerable value to the individuals involved in that particular study, there is a need for generalized technical assistance which can be made available to every engineer--available to whatever extent and in whatever form are dictated by the experience of the engineer and the requirements of the problem at hand.

Providing such assistance would surely narrow the technology gap, and the implementation of computer power by the development of user-oriented, universally-available computer programs such as the Generalized Computer Packages developed by the HEC appears to be a major step toward attaining that goal.

Power of the Computer . . .

The best available computer hardware and software do not approach the human brain in degree of sophistication, but they exceed it by many orders of magnitude in the speed of processing and documenting logical computation sequences. Consequently, elaborate computer packages solve problems with far more arithmetic effort than would be required by the human brain if the brain could solve the problem at all. The reason that the computer is valuable is that it can solve simple and complex problems dependably and cheaply. But the computer is invaluable in that it can persevere at acceptable cost to solve problems that require too much time or storage or transfer of information for the human brain to solve.

The fastest computers can perform 10,000,000 additions or 2,000,000 multiplications of 14-digit numbers per second and can go on for hours and hours without an error. Software is so sophisticated that a FORTRAN source program, easily written by an engineer, can be converted in a few seconds to a machine-language program that is more efficient than can ordinarily be developed by a professional programmer. This combination of speed and ease of use make the horizon of computer utility in engineering almost unlimited.

Associated Technology . . .

Many areas of mathematics have developed in recent years as a direct consequence of the power of the electronic computer. Of particular significance in the hydrologic engineering field are elaborate simulation, stochastic, and operations research processes. Water resource systems can be simulated in a degree of detail that was not physically feasible a few years ago. Stochastic procedures enable the engineer to make far more effective use of available hydrologic data in planning and operation studies. The degree of data coordination that is now possible was undreamed of a short while back.

Of particular value are the newly developed optimization techniques that constitute the field of operations research. These enable the computer to make many of the decisions that the technician and engineer formerly made. As problem size and complexity increase, optimization techniques will solve design problems that defy solution in terms of precomputer technology.

The Generalized Computer Package . . .

The concept of combining pertinent modern technical developments and the computational power of the computer are illustrated by the generalized computer packages developed in The Hydrologic Engineering Center. These are a natural consequence of using the computer to perform computations on many kinds of traditional problems in many technical areas of hydrologic engineering and to solve problems that could not previously be solved. The Generalized Computer Package is intended to perform virtually any desired sequence of computations in an entire operational area of hydrologic engineering that is separated from the overall water resource problem by the necessity to interpose the judgment of the design engineer. The secret to closing the technology gap is to enlarge these areas that can be isolated, thus increasing the preprogrammed decision area and reserving to the engineer only those decisions that require specialized background, information or criteria that cannot feasibly be generalized and preprogrammed.

The development of these packages will be a continuing undertaking and, if developed properly, they will represent the state of the art. This is a new concept of a "living" computer program that must grow or renew itself as new problems develop and as new techniques become available. The packages are in no way commensurate with an ordinary computer program that performs a rigid function or even with an integrated library of such programs. They can be manipulated easily to do a great variety of jobs, some simple, some complex, some approximate and some highly detailed.

At the present stage of development of computer packages, a complete hydrologic design might be accomplished in a single "run." This might

involve hundreds of thousands of minor computation sequences such as were the sole function of computer programs a few years ago.

For example, the hydrologic evaluation and some attendant economic analyses of an elaborately detailed multipurpose reservoir system operation plan for conservation purposes in one or more river basins can be accomplished in a single run, using computer package HEC-3. As another example, a number of development or operation plans for flood control in an entire river basin can be simultaneously evaluated in a single run, using computer package HEC-1.

A Detailed Example . . .

Program HEC-1, "Flood Hydrograph Package," enables the engineer to solve automatically for runoff characteristics such as unit hydrographs, loss relationships and routing coefficients, from observed station precipitation, snowpack, temperature and runoff data. It can be used for simple jobs such as a reservoir routing or for elaborate computations such as complete computations, plottings and summaries of design floods throughout a basin. It is possible to compute simultaneously 40 or 50 different floods at each location in any stream system, representing the range of floods that would occur under each of several plans of improvement or projected development and, at the same time, evaluate the flood damage for each flood at each location under each state of development and integrate average annual damages.

For each flood computation at each location, it is necessary to specify precipitation and, if snow is important, temperature for each interval during the flood period. If the energy budget method is used, radiation and other pertinent variables must also be specified. Provision is made for applying ratios and other adjustments to base patterns of precipitation, temperature, etc., so that these input data need not be repeated for every computation. Conditions in each sub-basin at the start of the flood, such as initial snowpack, loss coefficients, and degree of imperviousness must be specified. Drainage area size and unit hydrograph coefficients are also provided, and the computer will then compute the unit hydrograph, snowmelt, snowfall, new snowpack at each elevation during each interval, rainfall and snowmelt excess, and perform the repeated cross-multiplication operation to obtain runoff.

This runoff is usually routed through a channel reach or reservoir or both for combining with another hydrograph previously computed or to be computed and possibly also routed. For reservoirs, storage-outflow tables must be provided, and for channel reaches, routing coefficients for any standard method must be provided. Whenever all necessary hydrographs have been computed and routed to a particular location, the resulting hydrographs are combined into one, and computer storage space occupied by its components is released for storing new hydrographs to be computed.

Computation efficiency and job management considerations require that all operations to be performed at any location in the basin be done before moving on to another location. If 40 floods are being computed, they are all computed simultaneously as the computation process moves through the stream system. At each damage center, the peak flow of each hydrograph is found and the corresponding damage is determined from the flow-damage tabulation. These flows and damages are summarized, and damages are integrated. In order to integrate damages, each flood is automatically assigned a recurrence frequency based on a prespecified frequency tabulation for the location and for one specific basin condition or plan of development.

It can be seen that such an elaborate computation process requires extensive preparation of input data and results in large amounts of output. In order to minimize the work of preparing input and evaluating output, elaborate routines have been developed for managing input, suppressing unwanted output, and automatically summarizing and plotting the most pertinent portions of the output in forms directly usable in reports.

Program Management . . .

There is obvious need for different and more elaborate ways of performing all engineering studies, and it is difficult to envision ultimate development of the concept of the generalized computer package.

When programs provide this type of capability, there is virtually an infinite number of different paths that can be followed in different applications. Consequently, a package cannot feasibly be thoroughly tested. In each new application, there is need for a careful check by the engineer responsible for the job, but self-checking routines and printouts that provide information in the form, format and terminology familiar to the hydrologic engineer make the checks virtually as easy and dependable as checks on properly documented manual calculations.

Furthermore, almost every new major application entails system features that are peculiar to that river basin or that problem or that project. This means that the package may need some modification. A minor change in one "routine" can upset the systematic interaction of many routines as applied in a variety of other problems, and, therefore, it is often necessary to thoroughly retest the package whenever minor changes are made. It is not unusual to make 30 or 40 runs to modify a package to a new major problem. However, any other approach to the solution of the problem would be far more costly.

Although the development of a computer package might be justified by a single application in some cases, the number of major applications within the Corps is increasing rapidly. It is reasonable to expect that problems

requiring the use of these programs will exist in most Corps offices within the next few years. The programs do not, therefore, represent a rarely-used phenomenon, and surely their use will eventually be commonplace. Nevertheless, the packages cannot be relegated to a library but must be attended constantly by engineers versed in the subject matter. The continued usefulness of programs such as these can be assured only when a staff is available to help manage application and to assure continuous modernization.

A New Era . . .

There is a new challenge, not only in the demands on the engineer for the solution of increasingly complex problems, but in the availability of new computation capability and the almost unbelievable ramifications of associated mathematical developments.

The computer is not simply a technological tool like the slide rule or desk calculator. It is the means of revolutionizing engineering technology. Continued application of systems analysis, operations research, simulation techniques, stochastic analysis and other techniques to engineering problems by use of the computer must be emphasized if the technology gap is ever to be closed.

CLOSING THE TECHNOLOGY GAP

Discussion

Question, Mr. Renner: (1) Why not make your general purpose program conversationally-oriented so the user can react dynamically with the computer? (2) How about data management? Isn't it too difficult to input large amounts of data without error?

Reply, Mr. Beard: In our work, we have simply found that it is more economical and effective, with the facilities that we have, to run the job in batch mode. The engineer gives his job to the computer operator and devotes his attention to other matters until the completed job is returned. Probably the most programming effort goes into input management, and output management also requires large effort. The actual technical computations are a very small fraction of the program. The future will certainly see much more emphasis on output analysis within the computer, because the job of digesting output is often staggering.

Question, Mr. Curnutt: Short-sightedness seems to always be a problem. How do we look far enough into the future to see that the future needs are met?

Reply, Mr. Beard: Although design offices are always rushed to develop programs for immediate needs, attempts should be made to generalize the programs for future use. In the field of hydrologic engineering, the HEC can help in this regard, because it is our mission to increase the future competence of the Corps in this area.

Question, Mr. Matthews: What is your opinion of the operation of a computer terminal directly by a relatively high paid engineer?

Reply, Mr. Beard: If he is capable, I see no fundamental objection, except for the cost of his time. However, the engineer should never be required to do terminal input work that can be handled by clerks or technicians.

Question, Mr. Sharp: How well would HEC Packages lend themselves to a CORPS (Conversationally Oriented Real-time Programming System) type monitoring system, including user interrupt? Isn't it true that essentially the "same input data" would be required, regardless of whether conventional programming, ICES or conversationally oriented routines are used?

Reply, Mr. Beard: Yes. Although we feel that the type of work we do is most effectively accomplished without interruption of computer operations, it would be relatively easy to provide for interruptions in the programs when they would be operated in the time sharing mode. Ordinarily, I would expect this type of operation to be less economical, but we have not really tried it in view of the additional development time required to make the packages conversational.

Comment, Mr. Eichert: The following is offered in regard to Mr. Sharp's question concerning the desirability of communicating with the computer during the actual computer run. Most engineers feel that it is undesirable to do a huge job on the computer without checking intermediate answers first. This philosophy is accomplished in using the HEC program by making separate jobs out of pieces of the problems, checking the intermediate results, reprocessing if necessary, and finally processing the entire job.

Reply, Mr. Beard: This appears to be an excellent way of using the batch mode in a semi-conversational manner. It is necessary, of course, to run the job from the start every time.

GENERALIZED COMPUTER PROGRAMS

by

Dale R. Burnett¹

BACKGROUND

The San Francisco District has been utilizing electronic computers as an aid in hydrologic and hydraulic studies since about 1960. It was not until this year that we were able to have "in-house" computer facilities. Prior to this time we have operated under service contracts with various government and private facilities. This has not necessarily been a disadvantage although it probably has placed less emphasis on the development of computer programs in the District or the utilization of programs developed by others. Even with "in-house" facilities we are still making use of overnight service on a government leased CDC 6600 which is available for a very favorable cost and is more efficient for programs requiring a large amount of core storage such as Reservoir Water Supply Simulation studies, Regional Frequency Analysis, Monthly Streamflow Simulation, HEC Flood Hydrograph Package and a few others. Programming is primarily a function of the ADP group with engineers in other elements of the District outlining mathematical procedures to be used and desired output format. ADP started out under the Technical Service Branch but is now directly under the Division Engineer as a Regional Computer Center. During the past two years, as recent graduates have joined our Section, our programming capability has increased but is used primarily to make minor modification to existing programs. Also, with the availability of programs from HEC and other Districts, there is no longer the urgent need for new basic programs.

EQUIPMENT

The present "in-house" facility consists of a GE-Honeywell 427 system with 64K core storage using 24-bit characters, an 800-900 per minute card reader, 4 tape drives and 6-167 disk drives with a total capacity of 90 million characters, an on-line printer with a print speed of 1100 lines per minute and a 100-card/minute card punch. It is a multi-process environment system with a job stack converter. The satellite computers at the other two Districts are GE 225's with 8K memory core and 800-900 line per minute printers. The facility is being developed as a prototype for computer hardware being planned at other Divisions within the Corps.

¹ Hydraulic Engineer, Hydrology & Hydraulics Section
Water Resources Planning Branch, San Francisco District

DEVELOPMENT AND USE

The first work done on computers by engineers within the Hydrology and Hydraulics Section was the development of a water supply routing monthly simulation for a reservoir with releases made downriver to augment existing flows on the main stem from which M&I water supply diversions were to be made.² There were several control points having minimum flow requirements. This type of program has one of the greatest B/C ratios of any program utilized in the District and I am sure that there is no need to point out the many hours of tedious arithmetic that this program has spared. It was not a completely generalized program and required some modification for nearly every reservoir studied since that time. It has never been well documented and each new reservoir study requires a program writer to do some tailoring of control and check points and output format. Some have included power studies along with water supply studies. One program combines two reservoirs operated in tandem and one required the operation of twin reservoirs on parallel tributaries with a common reservoir pool at the higher elevations of the reservoir. The water surface profile computation both downstream and upstream from a control point and hydrograph from unit hydrograph were the next two programs which were developed because of the great percentage of time spent on these types of computations. Synthetic unit hydrograph derivation, frequency statistics, flow duration analysis, hydrograph routing through channel and reservoirs, simple linear correlation and others followed over the next few years.

A program which was developed within the past couple of years is the Interior Drainage Flood Routing Program for which there was a great need at various times. The program is working well and accounts for inflow from the interior area as well as seepage through levee systems and toe drain flows. The seepage can be put in as a hydrograph or computed from a differential head relationship. It is published as HEC 23-79 and has been amended only slightly from the published edition so that river conditions can be entered in the form of a stage hydrograph. This amendment facilitates computations where the tidal cycle has an influence on river stages.

Another program which has been particularly useful during the past year is the HEC Hydrograph Routing and Combining Program. The San Francisco District has had a channel routing program for some time which has proved very useful for routing reservoir holdouts and evaluating reservoir benefits but we have not as yet expanded the program to include local hydrograph generation or the capability of adding a known local inflow above a control point. The HEC program was used to evaluate reductions

2 The program was developed by I. H. Steinberg, Chief, Water Resources Planning Branch, San Francisco District, during water supply studies for the subsequently authorized Russian River, Dry Creek, Warm Springs Dam and Lake Sonoma Project, H. D. 547, Sept. 1962.

from reservoir holdouts and develop discharge hydrographs by combining 12 subarea hydrographs and routing through 6 river reaches with 20 sub-reaches.

Much use has also been made of the HEC-3 Reservoir System Analysis, Conservation Program. Other programs we are starting to use include the Reservoir Temperature Studies, Reservoir Delta Sedimentation and Deposit of Suspended Sediment. We have not expended a great number of man hours duplicating the effort of other Districts in writing programs, but have tried to make maximum use of existing programs.

SUGGESTIONS FOR IMPROVEMENT

I feel that the HEC Methods Systemization Manual "Preparation of Hydrologic Engineering Computer Programs," January 1970, is an excellent guide for preparing programs and that it should be followed by all Districts. Greater attention should be given to program documentation so that there can be a more profitable interchange of programs between Districts. Greater uniformity could be given to input format so that keypunch operators would not be required to remember details which are unique to each program. If the LX,F7.0,9F8.0 format is followed whenever possible, it would make their work more efficient. A standard Data Preparation Sheet of 10 fields could be used for most program inputs. We have utilized specially designed input sheets on most of our programs but the present tendency is to use the standard 10-field form along with a "users guide." Exhibits 1 and 3 are examples of forms which were thought to be an improvement over the standard form in that all variables are defined on the form and an input write-up is not required in order to prepare the input data. The reason for the restricted field on the title cards of Exhibit 1 is to confine it to the area allotted on the plot shown as Exhibit 2. Several plot packages have been developed in the District, using a Behnson-Lehner software package with modifications. There are some instances when this saves on engineering costs and could decrease drafting costs for reports. Exhibits 4a, b and 5a, b, c are examples of Reservoir System, Conservation Routing output which have been arranged and headed to be more convenient for ease in review, particularly for anyone not working with program output frequently. We should put as much thought into the output format as we do in any other phase of programming because of the time spent in understanding the volume of material which is generated from the computers.

In our District, we have been very inconsistent in the methods used to designate "stacking" and "end of Job." Sometimes we use a -1 punched a data column, sometimes a 2 punched in column 80, sometimes "end of job"

is called by three blank cards, four blank cards, the words "end of job" in the first field, etc. Unless there is a good reason to use a certain procedure, it would seem advisable to use a consistent procedure on all jobs within the District.

Engineers should take greater care in identifying and dating computer output so that it will have greater and longer lasting value as a permanent file document in those cases where the output is kept in study files. I particularly noticed this recently in reviewing output from the Hydrograph Routing and Combining Program where index points are identified by code number. It was very difficult to be certain just what location the code number represented. In most cases there is sufficient space in the three title cards to identify the code numbers by name. If three title cards are not adequate, it is a simple modification to provide greater flexibility in the number of title cards allowed. Also, I would like to see this particular program output arranged in a vertical format with a time (hour-day-month) column at the left and amended to allow reservoir holdouts to be combined at more than one downstream index point. This modification would perhaps decrease its usefulness as a "general" program but would make it more valuable in the majority of cases in the San Francisco District. The Methods Systemization Manual previously referenced contains many recommendations which, if followed, would improve the quality of our computer programs.

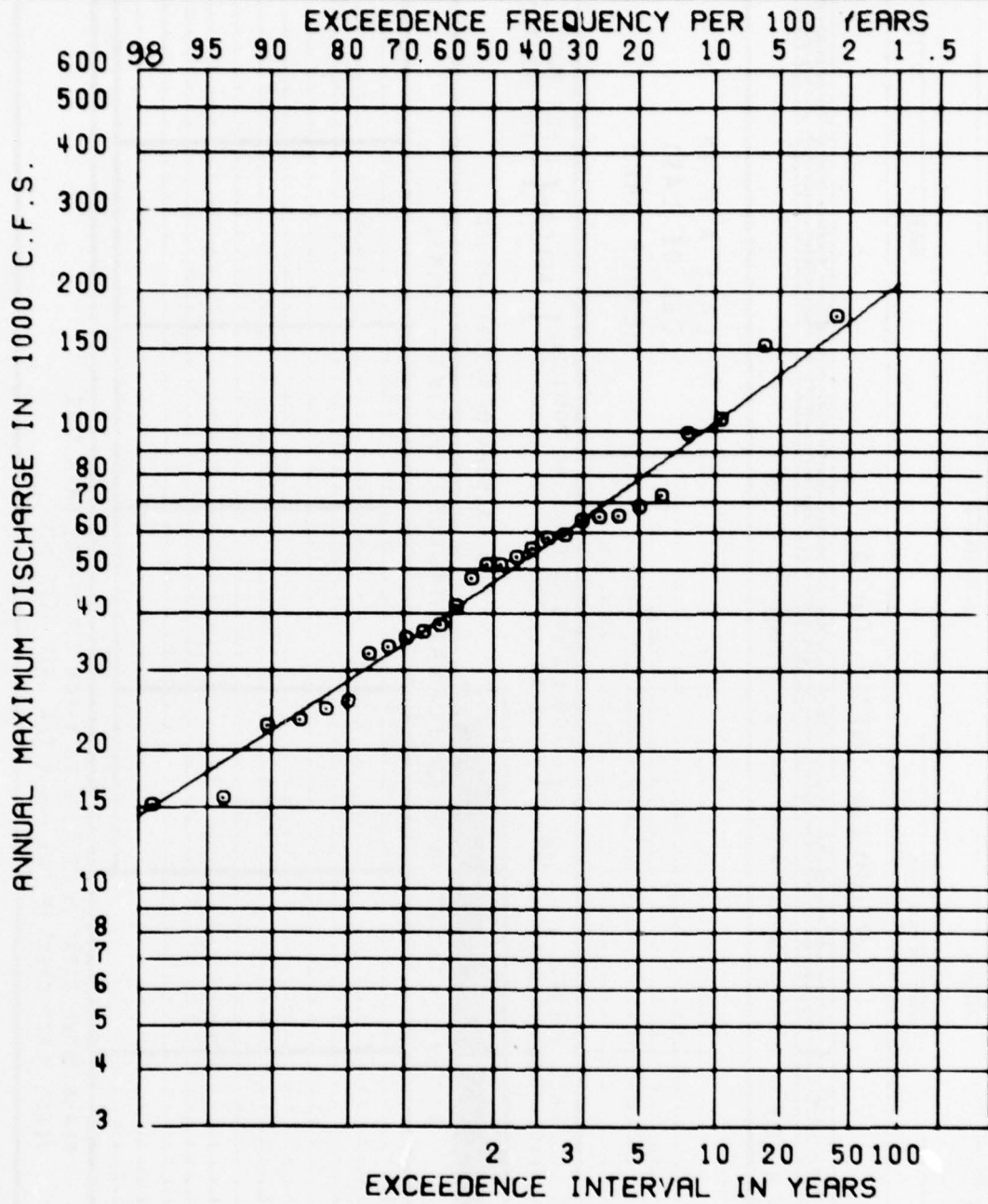

SO. FORK EEL R NR MIRANDA
YEARLY MAXIMUM DISCHARGE
FREQUENCY CURVE 1940-1967
GAGED VALUES

BEST AVAILABLE COPY

2317- INTERIOR DRAINAGE
FLOOD ROUTING

PROGRAM TITLE OR NUMBER

PROJECT

REQUESTED BY

SHEET 2 of 2

PRIORITY

WORK OR COST CODE

DATE

PROBLEM INPUT DATA

FOUR TITLE CARDS OR BLANK CARDS DO NOT USE THESE COLUMNS

NOTES	1	2	3	4	5	6	7	8	9	10	11	12	13	14	15	16	17	18	19	20	21	22	23	24	25	26	27	28	29	30	
CARD ORDER 7																															
CARD ORDER 8																															
CARD ORDER 9																															
CARD ORDER 10																															
CARD ORDER 11																															
CARD ORDER 12																															
CARD ORDER 13																															

L: STARTING HOUR NO: STARTING DAY MC: STARTING MONTH USE IF APPLICABLE (IF ISM: 1)
 SMT: INDICATES OUTPUT TIME FORMAT 2: 0 IF OUTPUT IS TO BE IN HOURS, 1: 1 IF OUTPUT IS TO SHOW HOUR DAY MONTH
 ISW2: DENOTES PUMPING CRITERIA: 0 IF NO PUMPING, 1 IF CONSTANT PUMPO RATE, 2 IF PUMPING IS VARIABLE (EL VS QP)
 JOBKD: PROGRAM CONTROL: 1 IF NEXT RUN USES NEW CARD ORDERS 7-13, 2 IF ALL NEW DATA, 3 IF LAST OR ONLY RUN OF JOB
 (CARD ORDER 11, 12, 13 MUST HAVE 2 CARDS IF USED)
 STEL: INTERIOR POND ELEVATION AT START OF ROUTING
 TOPEL: RIVER ELEV AT WHICH POND DISCHARGES CHANGE FROM GRAVITY TO PRESSURE FLOW
 PONEL: ELEV AT WHICH THE PUMP TURNS ON AND OFF IF APPLICABLE PUMPO: CONSTANT DISCHARGE IF APPLICABLE
 QG: GRAVITY DISCHARGE VALUES CORRESPOND TO ELPA VALUES OF CARD ORDER 1
 DELM: DELTA POND ELEVATION HEAD OGG: PRESSURE FLOW DISCHARGE CORRESPONDING TO DELM VALUE
 EL: ELONGING AREA ELEVATION QP: PUMP DISCHARGE CORRESPONDING TO EL VALUE (USE IF ISW2: 2)
 DELM2: SEEPAGE FLOW HEAD S1: SEEPAGE FLOW CORRESPONDING TO DELM2 VALUE (USE IF ISM2: 2)

SPW FORM 538-A
1 APR 65

WATER CONSERVATION HOULING
 MAU RIVER BASIN, BUTLER DAMSITE
 INFLOW INCLUDES RUTH SUPPLY

RUTH MIN. POOL = 9.8 T.A.F., BUTLER MIN. POOL = 20.0 T.A.F.
 CRITERIA FOR FISH RELEASES ARE BASED ON PERMISSIBLE FIRMSI OF MONTH STORAGES
 PLAN C, FULL M+I PLUS ACCRETIONS AND FULL FISH RELEASES. 9 FEB 1971

RUTH M+I REQUIREMENTS (TH.AC.FT.)

OCT= 5.9 DEC= 5.9 FEB= 5.8 APR= 5.8 JUNE= 6.6 AUG= 6.6
 NOV= 5.8 JAN= 5.8 MAR= 5.9 MAY= 5.8 JUL= 6.6 SEP= 6.5

BUTLER M+I REQUIREMENTS = 160.0 TH.AC.FT.

OCT= 12.8 DEC= 12.8 FEB= 12.9 APR= 12.8 JUNE= 14.4 AUG= 14.4
 NOV= 12.8 JAN= 12.8 MAR= 12.8 MAY= 12.8 JUL= 14.4 SEP= 14.4

IRRIG REQUIREMENTS = 0. TH.AC.FT.

OCT= 0. DEC= 0. FEB= 0. APR= 0. JUNE= 0. AUG= 0.
 NOV= 0. JAN= 0. MAR= 0. MAY= 0. JUL= 0. SEP= 0.

NORMAL FISH REQUIREMENTS AT MATCHERY(TH.AC.FT.)

OCT= 12.0 DEC= 18.1 FEB= 18.1 APR= 18.1 JUNE= 12.0 AUG= 6.0
 NOV= 18.1 JAN= 18.1 MAR= 18.1 MAY= 12.0 JUL= 6.0 SEP= 6.0

CRITICAL FISH REQUIREMENTS AT MATCHERY(TH.AC.FT.)

OCT= 7.8 DEC= 11.8 FEB= 11.8 APR= 11.8 JUNE= 7.8 AUG= 3.9
 NOV= 11.8 JAN= 11.8 MAR= 11.8 MAY= 7.8 JUL= 3.9 SEP= 3.9

NORMAL FISH REQUIREMENTS BELOW ARCAT(TH.AC.FT.)

OCT= 10.3 DEC= 18.1 FEB= 18.1 APR= 18.1 JUNE= 9.0 AUG= 2.7
 NOV= 18.1 JAN= 18.1 MAR= 18.1 MAY= 9.0 JUL= 2.7 SEP= 2.7

CRITICAL FISH REQUIREMENTS BELOW ARCAT(TH.AC.FT.)

OCT= 6.7 DEC= 11.8 FEB= 11.8 APR= 11.8 JUNE= 5.8 AUG= 1.8
 NOV= 11.8 JAN= 11.8 MAR= 11.8 MAY= 5.8 JUL= 1.8 SEP= 1.8

FISH REQUIREMENTS AT RUTH(TH.AC.FT.)

OCT= 2.5 DEC= 4.6 FEB= 4.3 APR= 4.5 JUNE= 4.5 AUG= 2.5
 NOV= 4.5 JAN= 4.6 MAR= 4.5 MAY= 4.6 JUL= 3.1 SEP= 1.8

RUTH MAX. STORAGE(TH.AC.FT.)

OCT= 51.8 DEC= 51.8 FEB= 51.8 APR= 51.8 JUNE= 51.8 AUG= 51.8
 NOV= 51.8 JAN= 51.8 MAR= 51.8 MAY= 51.8 JUL= 51.8 SEP= 51.8

BUTLER MAX. STORAGE(TH.AC.FT.)

OCT= 255.0 DEC= 205.0 FEB= 255.0 APR= 305.0 JUNE= 305.0 AUG= 305.0
 NOV= 205.0 JAN= 205.0 MAR= 280.0 MAY= 305.0 JUL= 305.0 SEP= 305.0

BUTLER MONTHLY PERMISSIBLE STORAGE FACTORS

OCT= .30 DEC= .40 FEB= .30 APR= .50 JUNE= .20 AUG= .40
 NOV= .40 JAN= .42 MAR= .45 MAY= .50 JUL= .45 SEP= .30

BUTLER MONTHLY PERMISSIBLE STORAGES (TH.AC.FT.), BELOW WHICH CRITICAL FISH RELEASES WILL BE MADE

OCT= 76.5 DEC= 42.0 FEB= 76.5 APR= 152.5 JUNE= 152.5 AUG= 122.0
 NOV= 82.0 JAN= 86.1 MAR= 126.0 MAY= 152.5 JUL= 137.2 SEP= 91.5

DATE	RUTH INFLOW (TAF)	RUTH FISH REL (TAF)	RUTH TOT. REL (TAF)	RUTH STOR (TAF)	SPILL (TAF)	BUTLER INFLOW (TAF)	BUTLER FISH REL (TAF)	BUTLER TOT. REL (TAF)	BUTLER STOR (TAF)	ELEV (FT)	SPILL (TAF)	FLOW PAST MATCH (CFS)	FLOW PAST ARCATATA (CFS)
1022	0.	0.	5.9	24.4	0.	5.9	12.0	30.7	191.3	540	0.	509	199
1122	1.2	4.5	6	25.0	0.	7.0	18.1	37.9	160.4	524	0.	661	375
1222	21.3	4.6	3	46.0	0.	92.4	18.1	19.4	205.0	547	29.4	1268	1275
123	25.7	4.6	3	51.8	19.6	104.0	18.1	18.4	205.0	547	85.6	2152	2129
223	13.1	4.3	3	51.8	12.8	49.5	18.1	30.0	224.5	556	0.	680	493
323	5.2	4.6	3	51.8	4.9	21.1	18.1	33.3	212.3	551	0.	632	376
423	21.7	4.5	3	51.8	21.2	93.3	18.1	19.1	286.0	583	0.	683	619
523	3.8	4.6	3	51.8	3.1	17.6	12.0	27.9	274.9	579	0.	535	275
623	1.0	4.5	3.9	48.4	0.	8.6	12.0	35.0	247.4	567	0.	605	274
723	.1	2.5	6.7	41.3	0.	8.3	6.0	28.7	225.7	557	0.	484	141
823	0.	.7	6.6	34.2	0.	7.1	6.0	27.5	204.1	547	0.	458	111
923	0.	.4	6.6	27.2	0.	6.8	6.0	27.2	182.7	536	0.	453	106
YEAR TOTALS					61.6 (TAF)		162.6 (TAF)			115.0 (TAF)		550.1 (TAF)	384.5 (TAF)
1023	.2	2.5	5.3	21.9	0.	7.3	12.0	32.1	157.3	522	0.	543	240
1123	.2	3.1	6.0	15.1	0.	7.9	18.1	38.8	126.4	504	0.	653	351
1223	2.4	4.6	3	19.2	0.	17.6	18.1	32.3	111.7	494	0.	626	376
124	5.6	4.6	3	23.5	0.	30.2	18.1	31.2	110.7	494	0.	673	469
224	17.7	4.3	3	40.9	0.	81.1	18.1	18.4	173.4	531	0.	724	695
324	2.4	4.6	3	43.0	0.	12.3	18.1	35.1	150.6	518	0.	643	376
424	1.6	4.5	3	44.1	0.	8.9	11.8	30.3	128.8	506	0.	548	270
524	.4	4.6	5.5	34.6	0.	8.7	7.8	29.3	107.6	492	0.	503	206
624	0.	.6	6.6	31.6	0.	7.0	3.9	24.9	84.7	475	0.	486	139
724	0.	0.	6.6	24.6	0.	6.6	3.9	24.9	65.6	460	0.	413	65
824	0.	0.	6.6	17.6	0.	6.6	3.9	24.9	46.7	442	0.	413	65
924	0.	0.	6.6	10.8	0.	6.6	3.9	24.9	28.0	419	0.	413	65
YEAR TOTALS					61.6 (TAF)		141.6 (TAF)			115.0 (TAF)		400.4 (TAF)	200.1 (TAF)

DATE	RUTH INFLOW (TAF)	RUTH FISH REL (TAF)	RUTH TOT. REL (TAF)	RUTH STOR (TAF)	SPILL (TAF)	BUTLER INFLOW (TAF)	BUTLER FISH REL (TAF)	BUTLER TOT. REL (TAF)	BUTLER STOR (TAF)	ELEV (FT)	SPILL (TAF)	FLOW PAST MATCH (CFS)	FLOW PAST ARCATATA (CFS)
1911-67*					934.5 (AF)		9196.8 (AF)			22087.7		49051.5	41704.6
MEMIOJ TOTAL					934.5 (AF)		9196.8 (AF)			22087.7		49051.5	41704.6
MEMIOJ MO. AV					13.7 (AF)		13.4 (AF)			32.3		71.7	61.0
MEMIOJ AVF.					164.1 (AF)		161.3 (AF)			387.5		860.6	731.7

TEST DATA PACKAGE NO. 2 4-19-69
 COYOTE AND WARM SPRINGS DAMS AS A UNIT
 UTILIZATION OF 20,000 A.F. OF FLOOD CONTROL STORAGE SPACE IN COYOTE Res.

POTTER VALLEY IMPAIRMENTS, IN 1000 ACRE-FEET
 OCT = 1.00 DEC = 0.00 FEB = 0.00 APR = 0.00 JUN = 1.10 AUG = 4.30
 NOV = 0.00 JAN = 0.00 MAR = 0.00 MAY = .10 JUL = 6.70 SEP = 2.90

MONTHLY M+I DEMAND BASED ON AN ANNUAL M+I DEMAND OF 190.0 THOUSAND ACRE-FEET
 OCT = 15.20 DEC = 9.50 FEB = 9.50 APR = 15.20 JUN = 20.90 AUG = 22.80
 NOV = 11.40 JAN = 5.50 MAR = 13.30 MAY = 17.10 JUL = 24.70 SEP = 20.90

RUSSIAN RIVER ABOVE HEADSBERG IRRIGATION REQUIREMENTS (WATER RIGHTS), IN 1000 ACRE-FEET
 OCT = 1.30 DEC = 0.00 FEB = 0.00 APR = 0.00 JUN = 1.40 AUG = 5.60
 NOV = .10 JAN = 0.00 MAR = 0.00 MAY = .10 JUL = 6.20 SEP = 3.30

RUSSIAN RIVER BELOW HEADSBERG IRRIGATION REQUIREMENTS (WATER RIGHTS), IN 1000 ACRE-FEET
 OCT = 1.00 DEC = 0.00 FEB = 0.00 APR = 0.00 JUN = 1.10 AUG = 4.10
 NOV = 0.00 JAN = 0.00 MAR = 0.00 MAY = .10 JUL = 4.60 SEP = 2.40

DRY CREEK IRRIGATION REQUIREMENTS (WATER RIGHTS), IN 1000 ACRE-FEET
 OCT = .10 DEC = 0.00 FEB = 0.00 APR = 0.00 JUN = .20 AUG = .80
 NOV = 0.00 JAN = 0.00 MAR = 0.00 MAY = 0.00 JUL = .80 SEP = .40

COYOTE DAM EVAPORATION FACTORS, IN ACRE-FEET PER ACRE OF SURFACE AREA PER MONTH
 OCT = .20 DEC = .20 FEB = .10 APR = .30 JUN = .60 AUG = .70
 NOV = .10 JAN = .30 MAR = .10 MAY = .40 JUL = .70 SEP = .50

WARM SPRINGS DAM EVAPORATION FACTORS, IN ACRE-FEET PER ACRE OF SURFACE AREA PER MONTH
 OCT = .24 DEC = .25 FEB = .08 APR = .28 JUN = .58 AUG = .66
 NOV = .11 JAN = .23 MAR = .02 MAY = .38 JUL = .71 SEP = .52

COYOTE DAM MONTHLY MAXIMUM ALLOWABLE STORAGE, IN 1000 ACRE-FEET
 OCT = 72.30 DEC = 72.30 FEB = 72.30 APR = 82.30 JUN = 92.30 AUG = 92.30
 NOV = 72.30 JAN = 72.30 MAR = 72.30 MAY = 92.30 JUL = 92.30 SEP = 92.30

COYOTE DAM MINIMUM ALLOWABLE STORAGE = 2 THOUSAND ACRE-FEET

COYOTE DAM STARTING STORAGE = 10 THOUSAND ACRE-FEET

WARM SPRINGS DAM MAXIMUM ALLOWABLE STORAGE = 225 THOUSAND ACRE-FEET

WARM SPRINGS DAM MINIMUM ALLOWABLE STORAGE = 13 THOUSAND ACRE-FEET

WARM SPRINGS DAM STARTING STORAGE = 28 THOUSAND ACRE-FEET

} 31,300 Ac.Ft. Irr.
 from Coyote

} Combined yield from
 two reservoirs

DATE	UNIMPAIRED FLOW AT GUERNEVILLE (1000 A.F.)	ADJUSTED FLOW AT GUERNEVILLE (1000 A.F.)	EAST FORK RUSSIAN RIVER NEAR UKIAH (1000 A.F.)	POTTER VALLEY POWERHOUSE RELEASES (1000 A.F.)	COYOTE DAM INFLOW (1000 A.F.)	FLCK AT RUSSIAN RIVER NEAR UKIAH (1000 A.F.)	RELEASES REQUIRED FOR MINIMUM FLOW AT THE FUPKS (1000 A.F.)
1262	5.2	3.0	3.3	13.4	12.7	14.4	1.5
1163	157.6	131.7	10.4	18.5	28.9	24.7	1.5
1263	31.0	23.5	2.1	17.6	15.7	20.1	1.5
1264	244.0	243.3	18.3	19.3	37.6	36.4	1.5
284	63.1	51.0	4.1	17.2	21.3	20.7	1.5
364	40.2	32.7	2.7	14.5	17.2	18.4	1.5
464	23.9	20.2	1.6	3.4	5.0	5.8	3.1
564	10.5	9.0	.7	5.0	5.6	3.8	5.4
664	14.1	13.2	1.0	4.7	4.6	2.5	4.6
764	13.3	12.2	.8	11.0	7.2	6.0	3.2
864	10.6	9.9	.7	10.5	6.9	7.3	1.9
964	4.8	4.5	.3	10.3	8.1	10.0	1.5
YEARLY TOTALS	661.4	555.7	43.6	144.9	174.8	170.1	28.7

RESERVOIR RELEASES REQUIRED TO SATISFY DEMANDS (1000 A.F.)	COYOTE DAM TOTAL DEMANDS (1000 A.F.)	COYOTE DAM EVAPORATION LOSSES (1000 A.F.)	COYOTE DAM STORAGE END OF MONTH (1000 A.F.)	COYOTE DAM END OF MONTH ELEVATION (FT. ABOVE MSL)	COYOTE DAM WATER EXCESS (1000 A.F.)	PROJECT CONDITIONS FLOW PAST GUERNEVILLE (1000 A.F.) (CFIS)
17.2	1.0	.3	59.1	729.3	0.	7.7
0.	1.5	-.2	72.3	737.3	14.3	137.5
0.	1.5	-.3	72.3	737.3	18.5	2292
0.	1.5	-.5	72.3	737.3	36.6	622
0.	1.5	-.2	72.3	737.3	20.0	4466
0.	1.5	.2	72.3	737.3	15.5	67.5
0.	3.1	.5	73.7	738.1	0.	40.9
5.0	10.3	.7	68.4	734.9	0.	660
11.1	2.4	1.0	62.0	731.2	0.	9.6
22.5	17.1	1.1	51.0	724.0	0.	124
22.7	19.9	1.1	42.0	717.8	0.	7.7
22.7	12.7	.7	36.7	713.8	0.	124
YEARLY TOTALS	105.6	4.4			105.0	7.4
						616.6

INFLOW TO WARM SPRINGS DAM (1000 A.F.)	RELEASES REQUIRED FROM DAMS (COYOTES SHARE) (1000 A.F.)	DAM TOTAL DEMANDS (1000 A.F.)	WARM SPRINGS DAM EVAPORATION LOSSES (1000 A.F.)	WARM SPRINGS DAM END OF MONTH STORAGE (1000 A.F.)	WARM SPRINGS DAM END OF MONTH ELEVATION (FT. ABOVE MSL)	WARM SPRINGS DAM EXCESS WATER (1000 A.F.)
3.3	3.0	11.3	.6	176.3	430.0	0.
15.8	0.	1.5	-.2	190.9	436.6	0.
5.2	0.	4.5	-.6	193.2	437.6	0.
22.3	0.	4.5	-.7	211.6	449.5	0.
3.0	0.	4.5	-.2	215.3	450.2	0.
4.3	0.	4.5	-.1	215.7	450.3	0.
2.1	0.	1.5	.8	215.5	450.3	0.
1.2	4.1	5.7	1.0	210.0	448.3	0.
6.0	5.3	7.9	1.5	201.2	442.0	0.
22.8	9.8	14.7	1.7	184.9	433.9	0.
22.7	8.0	16.2	1.5	167.2	425.5	0.
0.	7.0	17.2	1.1	148.8	416.2	0.
YEARLY TOTALS	62.1	64.1	6.5			0.

DATE	UNIMPAIRED FLOW AT GLENEVILLE (1000 A.F.)	ADJUSTED FLOW AT GJERNEVILLE (1000 A.F.)	EAST FORK RUSSIAN RIVER NEAR UKIAH (1000 A.F.)	POTTER VALLEY POWERHOUSE RELEASES (1000 A.F.)	COYOTE DAM INFLOW (1000 A.F.)	FLOW AT RUSSIAN RIVER NEAR UKIAH (1000 A.F.)	RELEASES REQUIRED FOR MINIMUM FLOW AT THE FORKS (1000 A.F.)
PERIOD TOTALS	62287.6	52627.5	4107.3	3501.4	11931.3	5765.9	3033.0
PERIOD MONTHLY AVERAGE	105.5	-86.1	7.0	14.5	20.3	9.8	5.2
PERIOD YEARLY AVERAGE	1271.2	1033.2	93.7	173.5	243.5	117.7	61.5

1965-64

PERIOD TOTALS	5408.5	5828.5	225.9	5846.2	5846.6	5846.5.6
PERIOD MONTHLY AVERAGE	9.2	9.9	.4	9.5	9.5	99.4
PERIOD YEARLY AVERAGE	110.4	118.5	4.7	119.3	119.3	1193.2

INFLW TO WARM SPRS DAM (1000 A.F.)	RELEASES REQUIRED FROM DAMS	WARM SPRS DAM TOTAL SHARE (1000 A.F.)	WARM SPRS DAM TOTAL DEMANDS (1000 A.F.)	WARM SPRS DAM EVAPORATION LOSSES (1000 A.F.)	WARM SPRS DAM END OF MONTH STORAGE (1000 A.F.)	WARM SPRS DAM END OF MONTH ELEVATION (FT. ABOVE MSL)	WARM SPRS DAM EXCESS WATER (1000 A.F.)
PERIOD MONTHLY AVERAGE	750.3	521.9	2477.0	2743.0	4265.1	319.8	2854.8
PERIOD MONTHLY AVERAGE	12.9	8.9	4.2	4.7	7.3	.5	4.5
PERIOD YEARLY AVERAGE	154.3	106.5	50.6	56.0	87.0	6.5	58.3

GENERALIZED COMPUTER PROGRAMS

Discussion

Question, Mr. D. Thomas: What has been the experience of various agencies in getting good documentation? Would a specialist in documentation help? Can guidelines be proposed?

Reply, Mr. Burnett: We have had minimum requirements and "guide lines" for some time. However, with a heavy work load it is easy to procrastinate the preparation of formal documentation other than that required by the "using" engineer. Although engineers or professional writers could be assigned this as a major job, it would seem more efficient for the program writer to document his own program and have it edited by other users and a well qualified writer.

Comment, Mr. Fredrich: The consensus of the persons to whom I have talked seems to be that the degree of documentation is related to the amount of technical assistance available to potential users. Programs for a depository must be much more thoroughly documented than programs which will be supported by a technical staff for any user's applications.

Comment, Mr. Price: For simpler programs good documentation is worthwhile. For more complex programs, complete documentation is almost impossible. For these more complex programs a person-to-person contact is, in my view, the most helpful way to learn how to use the program.

APPLICATION OF COMPUTER PROGRAMS TO HYDROLOGIC PROBLEMS
OF THE CENTRAL VALLEY OF CALIFORNIA

By

Richard E. Bennion¹

1. The Sacramento District extends easterly from the crest of the Coast Range of California to the Continental Divide in Wyoming and Colorado. It is one of the largest districts of the Corps. Because of the wide variation of climate in the district hydrologic problems are varied. Civil work projects include navigation and various types of flood control projects. Navigation begins in the tidewater area and extends about 100 miles up Sacramento River. Two deep water channels to inland ports have been constructed. Federal flood control projects include channel improvements, levee construction, diversion channels, detention reservoirs, single purpose operable flood control reservoirs, multipurpose reservoirs, and various combinations of storage and channel projects. A number of reservoirs in the district have been constructed by local agencies or other government agencies with Federal contribution for flood control and are operated under the provisions of Section 7 of the 1944 Flood Control Act. Three distinctive types of floods occur in the Sacramento-San Joaquin Basins, snowmelt, general rain and cloudburst. These floods range in characteristics from moderately high peaks associated with sustained high flows for months, to extremely high peaks with flood durations of only a few hours.

2. The paper consists of a series of seven short discussions concerning computer programs that have been and are being used in the Sacramento District for solution of hydrologic problems. Each discussion includes an identification of the program, a statement of the purpose, and outline of program function, and a discussion of the utility, adaptability and general effectiveness of the program. The first six are relatively small programs and the seventh is a large generalized program.

3. Following discussions of individual programs, there is a generalized statement appraising the effect of the ADP era on quality, quantity, and costs of hydrologic reports. Administrative aspects of transition into a computer age are also discussed.

¹Chief, Hydrology Section, U. S. Army, Sacramento District, Corps of Engineers, 650 Capitol Mall, Sacramento, California 95814

COMPUTER PROGRAMS

4. Program (HEC). -

723-110 Unit Graph and Loss Rate Optimization. Used on CDC 6600 or GE 7090 class. This is an adaptation of HEC 23-J2-L211.

a. Purpose and method. - This program is used for determination of optimized unit hydrograph and loss rates from precipitation and flood hydrograph data. It determines Clark's unitgraph if appropriate parameters are read in, or will determine best unitgraph from a synthetic time-area curve. Rainfall losses can be specified or a loss equation can be computed ($L = KP^e$) based upon reproductions of several floods for the basin being studied.

Trial reproductions of historical hydrographs are made using varying loss rates or methods of computing losses in a short period time. It provides a means of selecting the "best" combination of unit hydrographs and loss for a particular basin.

b. Discussion. - The program as proposed by HEC is used directly and has not required modification for applications made. Unit hydrographs and losses so developed give reasonable reproductions of historical events. Sometimes the optimized values do not fit too well on certain individual streams. The program presently is written to optimize more on the peak of the historical hydrograph rather than on the total volume. As a result, it does not give a true unit hydrograph and the volumes of these constituted hydrographs are often more in error than is desired. Applicability of the unit hydrographs and losses derived in flood synthesis requires use of judgement. No modifications of the program have been made as it has been incorporated into HEC-1.

5. Program (Sacramento District). -

723-AAA and -AAB Hydrograph Computation with or without Base Flow (also Tatum Routing or Precipitation and Snow Excess Distribution).

a. Purpose and method. - This basic program was developed to accomplish the cumulative multiplication required in using rainfall excess, unit hydrograph, and base flow to compute a flow hydrograph. Input is excess values in inches for successive periods, unit hydrograph ordinates and base flow. Computation of excess values must previously have been accomplished separately. Output is shown on example 1.

b. Discussion. - The program is very simple and can be applied to accomplish other purposes without modification. For example, this program can also be used for Tatum routing by feeding in hydrograph ordinates for "excess" and Tatum Steps for "unit hydrograph." "Base flow" cards could be used to add in a second hydrograph at the end of the routing reach.

Example 2 is an adaptation of 723-AAA to compute a percentage of another hydrograph, for instance a proportional flood of another basin, or a different frequency flood for the same basin if desired. This is done by using hydrograph ordinates for "excess" and a single percentage figure for "unit hydrograph," and "0" as base flow. In this instance base flow could be used to add a concurrent hydrograph. Column headings are modified when the program is used for other than the original purpose.

CREEK DA DA 11.0

EXAMPLE
Program 723-AAA

UNIT HYDROGRAPH

PERIOD	EXCESS	UNIT H-GRAPH	BASE FLOW	ORDINATE	SUMMATION
1	0.0000	528.00	110.	110.0	110.0
2	0.0000	2560.00	110.	110.0	220.0
3	.2700	3147.00	110.	252.5	472.5
4	.2200	1538.00	110.	917.3	1389.9
5	.4500	1071.00	110.	1760.4	3150.4
27	0.0000	45.00	110.	292.4	32445.3
28	0.0000	35.00	110.	260.5	32705.9
29	0.0000	27.00	110.	237.1	32943.1
30	0.0000	18.00	110.	225.0	33168.1
31	0.0000	15.00	110.	209.5	33377.6
32	0.0000	0.00	110.	190.1	33567.7
33	0.0000	0.00	110.	171.8	33739.5
34	0.0000	0.00	110.	153.5	33893.1
35	0.0000	0.00	110.	138.1	34031.2
36	0.0000	0.00	110.	127.8	34159.1
TOTAL	2.1300	14178.00	3960.	34159.1	34159.1

EXAMPLE 2
Program 723-AAA

RATTLE CREEK AT DIVERSION SITE

FIRST 5 DAY WAVE

100-YR

UNIT HYDROGRAPH

2 HR.

PERIOD	EXCESS UNIT HYDROGRAPH SPF.	UNIT HYDROGRAPH % SPF at Ratio	BASE FLOW	ORDINATE HYDROGRAPH	SUMMATION
1	3400.00	0.13	0.	433.5	433.5
2	3426.00	0.00	0.	436.8	870.3
3	3604.00	0.00	0.	460.1	1330.5
4	4268.00	0.00	0.	544.2	1874.6
5	5585.00	0.00	0.	712.1	2586.7
6	7556.00	0.00	0.	963.4	3550.1
7	10390.00	0.00	0.	1324.7	4874.8
8	15587.00	0.00	0.	1987.3	6862.2
9					
10					
11					
12					
13					
14					
15					
16					
17					
18					
19					
20					
21					
22					
23					
24					
25					
26					
27					
28					
29					
30					
31					
32					
33					
34					
35					
36					
37					
38					
39					
40					
41					
42					
43					
44					
45					
46					
47					
48					
49	4825.00	0.00	0.	615.2	119804.0
50	4328.00	0.00	0.	551.8	115416.4
51	4068.00	0.00	0.	518.7	115935.1
52	3932.00	0.00	0.	501.3	116436.4
53	3760.00	0.00	0.	479.4	116915.8
54	3543.00	0.00	0.	451.7	117367.6
55	3400.00	0.00	0.	433.5	117801.1
56	3400.00	0.00	0.	433.5	118234.6
57	3400.00	0.00	0.	433.5	118668.1
58	3400.00	0.00	0.	433.5	119101.6
59	3400.00	0.00	0.	433.5	119535.1
60	3400.00	0.00	0.	433.5	119968.6
TOTAL	940930.00	0.13	0.	119968.6	119968.6

Example 3 (723-AAB) is a modification of the original program. Decimal form ratio cards (as shown in Sacramento-San Joaquin Criteria Report, Chart 28) of a 96-hour storm are put in for "excess" cards. Total basin "excess" precipitation is put in for the "unit hydrograph" card. Snowmelt, if any, is put in on "base flow" cards. Column (5) is total precipitation by snowmelt. Note column headings have been changed on the machine printout.

EXAMPLE 3
PROGRAM 723-AAB

SPS CONC WITH SPECIFIC OVER LITTLE COW

Precipitation Distribution
UNIT HYDROGRAPH

PERIOD	% storm total PRECIP. ON SNOW EXCESS	storm total PRECIP. ON SNOW	Concurrent Snowmelt D-SNOW	D-PRECIP. AND-SNOW	SUMMATION
1	0.0000	19.1700	0.000	0.0000	0.00
2	0.0000	0.0000	0.000	0.0000	0.00
3	0.0000	0.0000	0.000	0.0000	0.00
4	0.0010	0.0000	0.000	0.0192	0.02
5	0.0010	0.0000	0.000	0.0192	0.04
6	0.0060	0.0000	0.000	0.1150	0.15
7	0.0110	0.0000	0.000	0.2109	0.36
8	0.0060	0.0000	0.000	0.1150	0.48
9	0.0070	0.0000	0.000	0.1342	0.61
10	0.0070	0.0000	0.000	0.1342	0.75
⚡					
80	0.0000	0.0000	0.000	0.0000	18.69
81	0.0020	0.0000	0.000	0.0383	18.73
82	0.0000	0.0000	0.000	0.0000	18.73
83	0.0020	0.0000	0.000	0.0383	18.77
84	0.0100	0.0000	0.000	0.1917	18.96
85	0.0090	0.0000	0.000	0.1725	19.13
86	0.0020	0.0000	0.000	0.0383	19.17
TOTAL	1.0000	19.1700	7a 0.000	19.1700	19.17

No real problems have occurred in program usage. The formats could be modified simply to give proper column headings for whatever purpose it is being used. Its use has greatly reduced hydrologic study costs because it has been used many times and does the work much faster than it could have been done with a desk calculator.

6. Program (Sacramento District). -

23-73 Time Distribution of Basin Mean Storm Precipitation

a. Purpose and method. - This program was developed to distribute total storm basin-mean precipitation into incremental amounts needed for flood analyses. It distributes total basin mean precipitation proportional to distribution for one or more recorder stations.

b. Discussion. - In Sacramento District, total storm basin-mean precipitation is generally determined by one of the following methods:

- (1) Computed from storm isohyetal maps.
- (2) Computed by use of ratios of station amounts to station NAP values and averaging indicated basin means.
- (3) Computed from station weights based on the "Thiessen Method" or some arbitrary modification thereof.

Time distribution of precipitation may be based on one or more recording precipitation stations. When more than one station is used for this purpose, desired station weighting can be applied.

Input is storm total precipitation amount and desired time incremental amounts of selected recording stations. Output format provides clock time with distributed amounts and a progressive summation of incremental amounts. The program also punches the distributed amounts so that the cards can be used as input data for other programs. Sample copy of printout, sample 4, is attached.

EXAMPLE 4
Program 23-73

MILL CR. ST. RECORD DATED 09 11 1963
STORM OF 14-22 JUN 1963 (55-0205)

BEGINNING DAY* 14 1963 ENDING DAY* 22 1963
BEGINNING TIME* 1000 ENDING TIME* 1000

STATION WEIGHTS* GRANT GROVE .75, PINE FLAT DAM .25
BASIN AVE PRECIP* 12.42 STATION WEIGHTED PRECIP* 17.77 RATIO* .697

ENDING TIME	DAY 1		DAY 2		DAY 3		DAY 4		DAY 5	
	AMT	SUM	AMT	SUM	AMT	SUM	AMT	SUM	AMT	SUM
100	0.000	0.000	.220	3.32	.005	7.65	.211	8.85	.052	12.12
200	0.000	0.000	.092	3.41	.010	7.66	.218	9.07	.025	12.14
300	0.000	0.000	.151	3.56	.026	7.68	.122	9.19	.028	12.16
400	0.000	0.000	.183	3.75	.005	7.67	.252	9.44	.015	12.17
500	0.000	0.000	.228	3.97	.062	7.73	.158	9.60	0.000	12.17
600	0.000	0.000	.432	4.41	.036	7.77	.057	9.66	.056	12.21
700	0.000	0.000	.265	4.67	.020	7.79	.193	9.85	.120	12.33
800	0.000	0.000	.226	4.90	.010	7.80	.026	9.88	.020	12.35
900	0.000	0.000	.745	4.94	.012	7.81	.123	10.00	.022	12.37
1000	0.000	0.000	.050	4.99	.005	7.82	.214	10.22	.020	12.39
1100	.008	3.000	.219	5.21	0.000	7.82	.103	10.41	0.000	12.40
1200	.057	.06	.356	5.56	.038	7.82	.231	10.64	0.000	12.40
1300	.123	.18	.244	5.82	0.000	7.82	.104	10.74	0.000	12.40
1400	.195	.38	.233	6.05	0.000	7.82	.015	10.76	0.000	12.40
1500	.214	.59	.350	6.40	0.000	7.82	.061	11.12	0.000	12.40
1600	.305	.90	.205	6.56	.010	7.83	.067	11.17	0.000	12.40
1700	.240	1.14	.287	6.85	.036	7.87	.125	11.29	0.000	12.40
1800	.308	1.45	.282	7.13	.020	7.89	.101	11.39	0.000	12.40
1900	.373	1.82	.144	7.28	.104	7.99	.125	11.52	0.000	12.40
2000	.354	2.18	.366	7.35	.082	8.09	.135	11.65	0.000	12.40
2100	.297	2.45	.393	7.33	.130	8.22	.136	11.78	0.000	12.40
2200	.287	2.73	.130	7.49	.087	8.30	.136	11.90	0.000	12.40
2300	.237	2.97	.083	7.57	.151	8.45	.115	12.01	0.000	12.40
2400	.146	3.12	.048	7.62	.163	8.64	.052	12.06	0.000	12.40
DAY TOTALS	3.12		4.50		1.01		3.42		.33	

7. Program (HEC). -

723-GIL-2320 Hydrograph Combining and Routing

Will run on GE 225 series or larger.

a. Purpose and method. - This program combines gaged flows and routes them through river channels. It computes ungaged inflows occurring between successive index points. It can also route through reservoirs which have a known storage-outflow relationship.

b. Discussion. - This program is particularly adaptable for computing flows with ratios of initial input hydrographs, as it can handle a large number of input increments. The district has used this extensively in routing various flood series, such as SPF, 100-year and 50-year floods. The reservoir routing routine is the limitation, as computations for this routine are more complicated than channel routing routine. With the district's GE 225 computer the program limitation is 250 hours and with the CDC 6600 the limitation is 500 hours. This program has been used extensively in the past and will probably be continued in use for applicable problems.

8. Program (Sacramento District). -

723-GI-12-AFO Unit Hydrograph Computation

Computes synthetic unit hydrographs.

a. Purpose and method. - This program computes a unit hydrograph by use of drainage basin characteristics, a summation hydrograph generally known as the "S" graph a predetermined set of lag relationship curves (roughness coefficient noted below is used as a parameter).

b. Discussion. - Drainage basin characteristics include area, length of main stem of stream (L), length from computation point to center of the area (Lca), average slope of the main stem (S), and an estimated average basin roughness coefficient (\bar{n}). The program has been used extensively in developing unit hydrographs for urban areas and to some extent for small drainage areas, particularly those where the cloudburst type storm produces critical floodflows. Its chief advantage is that physical dimensions of the basin can be determined quickly from available topographic maps. It has also been an inexpensive device to verify unit hydrographs determined by other means.

9. Program (HEC). -

723-AGO Unit Graph and Hydrograph Computation; will run on GE 225.

a. Purpose and method. - This program computes unit graphs by Clarks Method and uses either computed water-excess or storm precipitation and loss relationships to compute water-excess, then accomplishes the unit hydrograph routing to compute flood runoff.

b. Discussion. - Program accepts rainfall in inches, or as proportional increments of specified storm total. Program computes rain excess by use of either an initial loss and uniform loss rate, or the loss equation $L=KP^e$. The changes were made in instructions pertaining to the use of the loss equation, $L=KP^e$. The first change was to replace the initially specified ΔK from 0.2 ΔL to any desired ratio of ΔL in order to obtain better reproductions of the observed hydrographs. The second change involved a modification so that losses can be computed to any designated time increment rather than the 1-hour increment originally used in the program.

The program has been incorporated in other generalized programs and its future use will be limited largely to studies involving computing flows in a stream at a single index point.

10. Program (HEC). -

23-X6-L268 Regional Frequency Computation

Must run on CDC 6600, or IBM 7094 class.

a. Purpose and method. - Performs statistical analysis for computations of minimum annual flood frequency for peaks, 1, 3, 10, 30-day mean flows.

b. Discussion. - This program can be used for analyzing one station at a time or more than one station. If more than one station is used the program will correlate data between stations for each duration being used, compute correlation coefficient "R", and estimate missing data at any station whenever there is data available at one or more of the other stations. Program also estimates missing peaks when daily flow data is available.

When desired, skews and standard deviations can be inserted as input data for use in computing frequency curve coordinates. Usually, however, the skew, standard deviation, and mean values are not fed in, and machine computes these values.

Program output lists both recorded and estimated data (the latter noted with an "E") arranged in descending order of magnitude for each duration. Also, correlation coefficients between stations for each duration are given for the three following conditions.

- (1) For actual recorded data.
- (2) For recorded and estimated data.
- (3) For smoothed conditions (labeled as adopted statistics).

Program has been used considerably in developing frequency curves in order to adhere to the "Water Resources Council Procedure." This program computes required values for plotting a statistical curve. The computed SPF values are indicated on the frequency plot and when deemed necessary, the curve is modified graphically.

11. Program (HEC-1). -

723-X6-L2010 Flood Hydrograph Package

a. Purpose and method. - HEC-1 computes flood hydrographs, optimizes loss rates and unit hydrographs, calculates basin precipitation, routes and combines flood hydrographs and routes floods through detention type reservoirs.

With this package all hydrograph computations associated in the historical or hypothetical storms, channel routing and reservoir routing where outflow is a function of storage and inflow can be accomplished for a complex river system. Routings include rainfall and snowmelt determination, computation of basin precipitation from station values, unit hydrograph determination, hydrograph calculation, various methods for channel and reservoir routing and complete stream system hydrograph routing and combining. Unit hydrographs, loss rates, snowmelt, freezing temperatures and best fit routing coefficients can be derived automatically from historical storm and flood data.

b. Discussion. - HEC-1 is being used in the Sacramento District to route historical and hypothetical floods in the upper Sacramento River system through detention reservoirs and to various points of interest. The reservoir routing routine does not lend itself for reservoir system routing, because the program does not make use of reservoir parameters and downstream flood control objectives. In the determination of flows from ungaged areas, unit hydrographs, and loss rates were developed from historical events for gaged tributaries by use of the optimization routine of the program. The unit hydrographs were comparable to those developed by the S-curve method. See page 10. The use of flood ratios for the simultaneous calculation of a whole range (10-year to SPF) of hypothetical floods was a major time saver to reduce the total computer time for any run, the hydrograph plotting routing was modified to allow for greater flexibility in the choice of the location of the plot. An instantaneous peak calculation was added to the summary routine to make interpretation of hydrographs easier.

The upper Sacramento River system encompasses eleven routing points on the main stem of the river, historical and hypothetical outflows from seven reservoirs and flows from thirty areas of which less than half were gaged. These were routed and combined to derive the total flow at Ord Ferry. Hypothetical flood series were developed to be used by the Reservoir Regulation Section in a reservoir systems analysis. A routing schematic is shown on Example 5 on page 11.

This program is also being used in the Walnut Creek and Coalinga Creek Basin studies. For the Walnut Creek Basin hypothetical local storms were developed by use of percentage distributions of the storms with initial and constant losses. However, for the Coalinga Creek Basin, the hyperbolic loss function was used in derivation of hydrographs. To accomplish the objectives in these studies it was found to be advantageous to modify the loss calculations as follows:

(1) The uniform and maximum allowable loss rates were changed in their dimensions from inches per hour to inches per selected time interval.

(2) For greater flexibility of the hyperbolic portion of the loss rate function, the constant (0.2) was changed to a variable as indicated on page 8.

(3) The loss calculations within the runoff routine have been modified such that either initial or constant losses can be satisfied first. A negative value of the initial loss calls for the uniform losses to be satisfied first.

The package program will probably be modified to satisfy the specific requirements for each major basin use. Use to date has demonstrated that this generalized program provides an economical solution to complex hydrologic problems. For complex applications a considerable amount of set up time (data management and becoming familiar with the program) is required. Once users are aware of all aspects of the program, it becomes a very effective and time saving tool. Application in the Sacramento District has indicated a need for more thorough documentation of the program and need for more descriptive language in this documentation.

Example 5

Schematic For

Upper Sacramento River

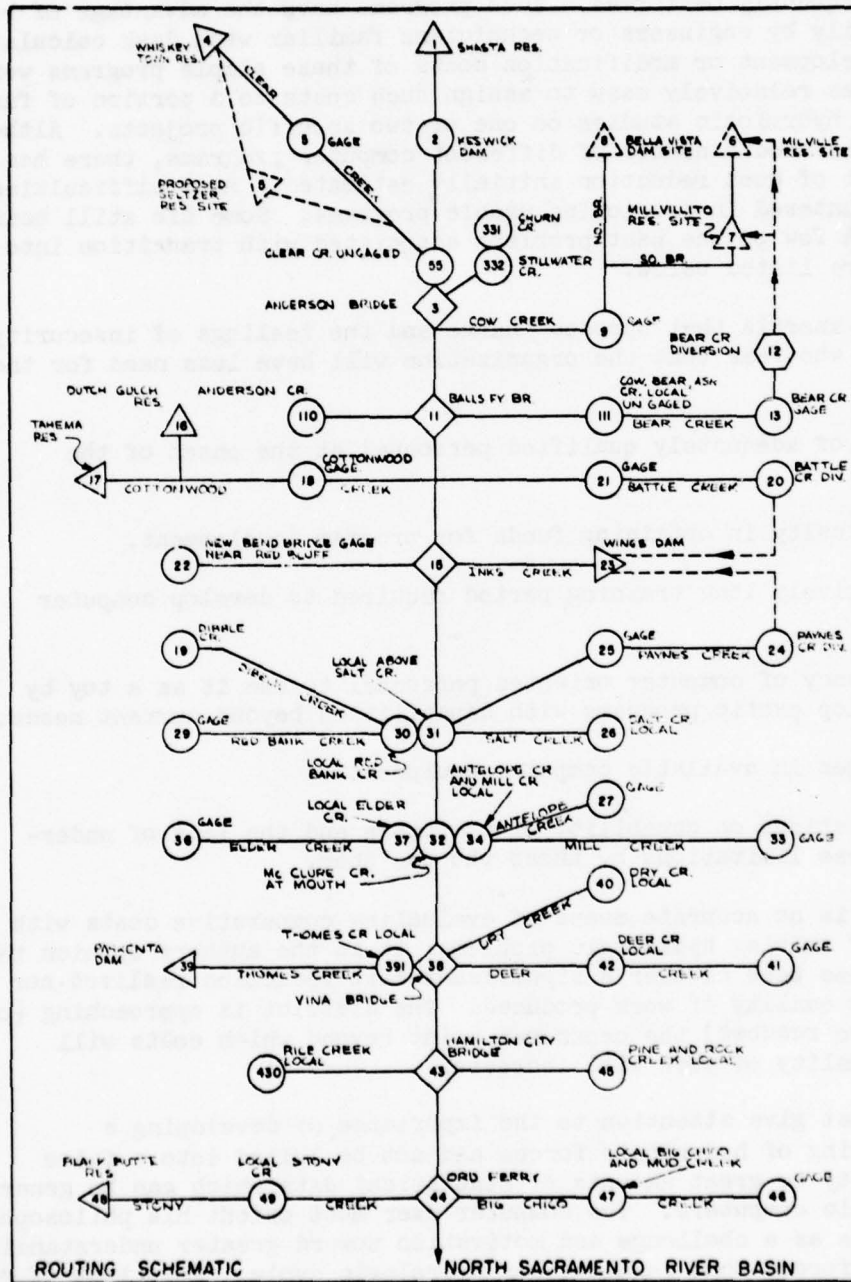

GENERAL DISCUSSION

Most computer use to date in Sacramento District has involved the simple programs designed to accomplish one-step or two-step problems. The computer was used to eliminate time consuming desk calculator computations, particularly of types frequently performed. Such programs have the advantage of being understood easily by engineers or technicians familiar with desk calculator problems. Development or modification costs of these simple programs were small and it was relatively easy to assign such costs to a portion of funds allocated for hydrologic studies on one or two specific projects. Although the district has used a number of different computer programs, there has not been the amount of cost reduction initially estimated. Many difficulties have been encountered in developing usable programs. Some are still being encountered. A few of the past problems associated with transition into the computer era are listed below.

- (1) Human inertia that opposes change and the feelings of insecurity in individuals who fear that the organization will have less need for their services.
- (2) Lack of adequately qualified personnel at the onset of the computer era.
- (3) Difficulty in obtaining funds for program development.
- (4) Relatively long training period required to develop computer proficiency.
- (5) Tendency of computer oriented personnel to use it as a toy by trying to develop exotic programs with capabilities beyond current needs.
- (6) Changes in available computer equipment.
- (7) Limitations on capability of computers and the lack of understanding of these limitations by those who use them.

Although there is no accurate means of evaluating comparative costs with former means of solving hydrologic problems, it is the authors opinion that to date there has been neither a significant cost reduction realized nor increase of the quality of work produced. The district is approaching (or may already have reached) the crossover point beyond which costs will decrease and quality of work will increase.

Hydrologists must give attention to the importance of developing a deep understanding of hydrologic forces and not be lulled into a false sense of security by great amounts of statistical data which can be generated by the electronic computers. The computer user must orient his philosophy to use the machines as a challenge and motivation toward greater understanding of the natural forces that regulate our hydrologic cycle. This task of deep

hydrologic indoctrination bears heavily on the shoulders of experienced hydrologists that have grown up the hard way and they must assist the newcomer in obtaining a deep understanding of his responsibility to advance the art and to serve his clients well. This tool if used wisely will enable him to accomplish infinitely more and better quality of work than his predecessor.

The outlook for the future appears much brighter than the results achieved to date. Proven programs are available for most of the time consuming hydrologic computations. The experience of engineers and technicians in computer programing is now approaching a desirable level. New engineers are being trained in computer application as a part of their basic engineering training, so they will enter into their professional careers better equipped for the challenge of this day and of the future.

APPLICATION OF COMPUTER PROGRAMS TO HYDROLOGIC PROBLEMS
IN THE CENTRAL VALLEY OF CALIFORNIA

Discussion

Comment, Mr. Beard: Mr. Bennion implied that his use of HEC on short-time consultation frequently, since his staff is near HEC, might unduly impose on HEC. For the benefit of the Corps representatives here, I simply want to make it clear that the HEC exists solely to assist Corps offices in any way that we can and that we are more than happy to work with the Districts in any way that they desire. Also, we hope that the matter of pride of authorship doesn't inhibit cooperation with HEC. It is not the function of HEC to become a center of competence dispensing knowledge, but to work cooperatively with field offices to increase the competence of the entire Corps in the hydrologic engineering field.

Reply, Mr. Bennion: I feel that you have demonstrated this in our relationship and by the assistance we have been given. My men have expressed their appreciation especially for help from A. J. Fredrich.

Question, Mr. W. Thomas: Has your idea of encouraging your young engineers to develop some of their own computer programs increased the insight or "feel" for hydrology that you are trying to impart to them.

Reply, Mr. Bennion: This question can only be honestly answered in a few years from now, but it is my real hope that this is the case. I do see some evidence of development.

Comment, Mr. Sharp: Mr. Bennion, you have expressed a reluctance of your office to become computer oriented and a reluctance to place a great amount of confidence in computer programs, not only developed by others, but by yourself as well. However, it appears from the content of your paper that perhaps you may be more of a convert to ADP than you realize, or are willing to admit. In any case, I'm sure that all of us here who have been actively engaged in hydrologic engineering applications with the computer have a great deal of respect for your worthwhile transition into computer usage. Many of our offices have not displayed such a change, which is most important. In this transition you chose to modify a few of the HEC programs, presumably to render them more suitable to your needs and confidence, and I'm sure you must consider yourself in a better position to stand behind any such modifications, which would require explanation in design memorandums and other reports.

Reply, Mr. Bennion: We try only to modify to the extent necessary to make the programs functional for our purposes. As I tried to point out in the presentation, these have been frustrating experiences with respect to funding for program development or adaptation. This in a large measure I am sure was due to lack of adequate training of those attempting the program modification.

Any reluctance I have felt toward computer use has stemmed from the hard necessity of getting a given job done within fund limitations.

COMPUTER APPLICATION FOR
INTERIOR DRAINAGE STUDIES
ST. LOUIS DISTRICT
by
JERRY L. CURNUTT

1. INTRODUCTION.

The first question a person might ask is, "What is an interior drainage study?" After the design or construction of a levee, protecting an area from direct flooding by a river, a study is made to determine methods of alleviating flooding on the landward side of the levee caused by interior runoff. This runoff would result from seepage through the levee during high river stages and from rainfall over the bottom lands and adjacent hill land areas. Means of alleviation studied include: small reservoirs in the hill land; diversion channels; enlarged ditching; additional drains through the levee; and pumping stations. Because of the heavy development of the land, improvements are usually limited to the last three methods. Therefore, the study will determine the degree of improvement at the outflow point that can be economically justified to reduce the annual flood damages. Plate 1 illustrates a plan view of a typical flood plain area to be investigated for an interior drainage study.

The St. Louis District has been involved in interior drainage studies for about 20 years. In the first studies all computations were done manually and the time required to study one pump station was staggering. The gravity outlets were not investigated with the pump stations due to the additional time involved. To eliminate the great volume of manual computation, the District developed an interior drainage program in 1965. The analysis was still rather simplified inasmuch as the same procedures

were used in the program as were previously performed manually. Only the periods of blocked drainage were investigated and no consideration was given to periods of runoff when the river was low. By 1968, it was evident that a new approach to interior drainage studies was needed since all periods of flow needed to be examined to determine the best plan of improvement. The computer program in use at that time was inadequate because of the simplified approach and general assumptions used in the program. Several programs developed by other districts were investigated but none met the desired criteria of pumping with the gravity drain in operation. Consequently, it was decided to develop a new program that would be general enough to handle the various combinations of river stage, gravity drain flow, and pumping, but would be in sufficient detail to provide information for economic analysis. The program has been operational for several months and, based on preliminary results, it appears to be the most comprehensive interior drainage program in use at the present time. The program has been assigned the number 723-R1-A3-530.

2. GENERAL METHOD OF ANALYSIS.

Interior drainage analysis is based on the evaluation of flood damages for each area where improvements are contemplated. The evaluation covers the full period-of-record, both with and without the improved drainage facilities in place.

''

The basic steps involved in performing the hydraulics portion of an interior drainage study are:

- a. Prepare inflow and river stage data.
- b. Analyze existing and additional gravity drains.
- c. Analyze the various pumping capacities.

The program will evaluate, for the full period of record, up to five conditions of gravity drainage, pumping and ditching, and overflow into adjacent subareas. The first condition will only consider no-pumping (gravity drain being the only means available to remove water), whereas the second, third, fourth, and fifth conditions can include various combinations of gravity drain and pump capacities.

3. INFLOW PROGRAM.

The inflow used in the interior drainage program is computed in a separate program No. 723-R1-A3-470. The program computes the inflow

due to rainfall and seepage, and the daily river elevation. Daily runoff is computed by the use of rainfall, runoff factors, and drainage areas.

a. Rainfall runoff. The inflow from rainfall runoff used in the daily routings are developed for each pump station location from the Weather Bureau, U.S.G.S., or Corps records of rainfall at the long term gage nearest to the study area. The rainfall is applied to variable runoff coefficients to convert daily rainfall into daily runoff values and is a major change from past programs. Coefficients for each of the four seasons of the year were determined from data developed in previous studies, using the ASCE Hydrology Handbook as a major reference. The rules listed in the above mentioned publication were applied to previously determined coefficients for hill lands and bottom lands. These rules state: "There is no dependable method for correcting infiltration capacities for specific seasons. A review of the scant data available, however, suggests that as a "rule of thumb", the summer values should be multiplied by approximately 0.75 to estimate the winter capacities, and by approximately 0.85 to indicate the rate during the transition periods of low biologic activity between summer and winter. These factors do not apply to frozen soils." These seasonal coefficients, the area of the hill and bottom lands, and the daily rainfall amounts are used to compute the runoff in day-second-feet for each area where a pump station is proposed.

b. Seepage. Seepage is also included in the computation of inflow used in the routing program. Discharge rating curves for varying heads are developed for each seepage well located in the study area. Composite curves are then prepared using the seepage well curves located in that specific pump station area. Plate 2 shows an example of the head versus seepage curve used in the program. The seepage values of inflow are added to the daily runoff inflow to achieve the total inflow value.

c. River stage transfer curve. The daily river stage data at the nearest main stem gage are transferred along the river profile to the gravity drain site where improvements are proposed. This is done by developing a relationship between the water surface elevation at the gage and the water surface elevation at the pump station site and is used to give a better river stage reading at the actual location of the gravity drains. The stages from the recording gage are converted in this program so these computations were not required in the routing program.

4. GRAVITY DRAIN AND PUMP ANALYSIS

All of the flood plain areas located within the St. Louis District subject to possible interior drainage studies are small enough for runoff

to travel to the proposed pump station site within 24 hours. Therefore, the program was developed to perform a daily routing. This routing combines rainfall and seepage runoff, routes it to the pump station location, computes the outflow, then determines the daily acres flooded. The District's needs were best served by a daily routing, due to the number of long term gages located within the St. Louis District. The periods of record to be used in the program vary from about 30 to 65 years.

a. Curves needed and method of use. Most of the control parameter data is stored in the computer in coefficient form for second degree curves. Coefficients rather than tables are used to fully utilize the limited amount of computer storage available. The curves used in the program are:

- (1) Storage curve (storage in dsf versus elevation).
- (2) Storage curve (elevation versus storage in dsf).
- (3) Area curve (acres versus storage in dsf).
- (4) Seepage curve (seepage in cfs versus head).
- (5) Gravity drain rating curves (elevation versus discharge in cfs).
- (6) Ditch rating curves (elevation versus discharge in cfs).
- (7) Pump efficiency curve (head versus fraction of full capacity in percent).
- (8) Overflow curve (elevation versus discharge in cfs).

After the data for the curves are developed, another program (No. 704-R1-A3-59M) is used to compute the A, B, and C coefficients for second degree equations ($Y = AX^2 + BX + C$) by the least squares method. In many instances, a value of zero is computed for the A coefficient and the segment becomes a straight line. This program also computes X and Y coordinate values by the use of the coefficients. These computed X and Y values can be plotted and compared to the original curve segment. If care is taken in selecting the original points used to

compute the A, B, and C coefficients, the computed curves will closely approximate the original curves.

b. Gravity drain rating curves. An example of the type of gravity drain curves used in the program is shown on Plate 3. Each set of these rating curves consists of two distinct parts: the free-flow rating curve and a series of restricted-flow curves. The free-flow rating curve is used when the river is low and does not impede gravity drain outflow. The restricted-flow rating curves are used when the river is affecting the discharge through the drain. The latter curve must be developed for each foot of river elevation, starting one foot above the gravity drain landside invert and continue in one-foot increments to the top of the drain. Along with the gravity drain rating curve inputted in equation form, several other variables for the gravity drain are required. Plate 4 is a schematic cross section of a typical pump station location, showing some of the variables. One of these values, affecting the use of the gravity drains, is the river control elevation. This elevation is the point at which the gravity drain is considered closed, irregardless of the landside ponding elevation. The river control elevation is selected by assuming that access to the closure structure would be practically impossible when the river exceeded this value. When the river elevation is below this value, the gravity drain is assumed to be open when there is a sufficient head differential between the landside ponding elevation and the river elevation. Discharge through the gravity outlet can therefore be achieved even during high river stages. The head differential is determined for each pump station location and is provided in the control parameter deck.

c. Ditch rating curve. The inputted capacity of the ditch leading to the proposed pump station location generally equals or exceeds the capacity of the gravity drain. If the capacity of the ditch is less than the combined capacity of the gravity drain and pump station, the flow is retarded and this prevents the system from operating at full capacity. The program can be used to determine the required ditch size by equating ditch capacity to the optimum pump and gravity drain capacities.

d. Routing procedure. The routing procedure is somewhat different in its approach. A schematic diagram of the method is shown on Plate 5. The program begins the routing procedure by setting the end of the day storage (E.D.S.) equal to the beginning day storage (B.D.S.) of the next day. The inflow is then added to the B.D.S. to give the maximum storage. An average storage value (between B.D.S. and maximum storage) is used to initially compute the outflow. This outflow value is then subtracted from the B.D.S., giving a minimum storage. The maximum and minimum storages are averaged and this half storage value is then

averaged with the E.D.S. to find a value to recompute a mean daily outflow. This outflow is subtracted from the original B.D.S. resulting in a new E.D.S. If the half storage and the E.D.S. are equal, or within a tolerance set for each specific area, the E.D.S. is accepted as good and the routing proceeds to the next day. If the half storage and the E.D.S. are not equal, the maximum storage or minimum storage is revised. When the half storage is larger than the E.D.S., the half storage becomes the new maximum storage and a new half storage value is determined at the beginning of the next cycle. However, if the half storage is smaller than the E.D.S., the half storage becomes the new minimum storage and a new half storage value is determined at the beginning of the next cycle.

e. Pumping. Pumping can occur with or without gravity drain flow during the routing study. When pumping, a start pump elevation must be supplied. The full capacity of the pump station is assumed to be in operation when this elevation is reached. A pump efficiency curve must also be provided for the daily routing. This curve is used to compute the actual capacity of the pump station operating under various head conditions. The curve reflects a reduction in pump capacity due to the increase in static head measured from the ponding elevation to the river elevation. The curve must start with 1.0 (100-percent capacity) at zero head. An example of this curve is shown on Plate 6.

f. Overflow into subareas. In the St. Louis District, many of the subarea drainage divides in the flood plain are so low that they will pond only a limited volume of water before overflow into an adjacent subarea occurs. In general, this condition is prevalent only during prolonged periods of blocked drainage coinciding with severe rainfall in the area. A rating curve of discharge versus elevation at the area of overflow is developed to account for this occurrence. An example of this curve is shown on Plate 7. A discharge rating curve, based on open channel flow, appears to adequately represent the natural flow from one subarea into another. The curve can be developed by the use of Manning's Equation for open channel flow after determining an approximate cross section of the low swale where overflow will occur. When this happens, the mean daily values of overflow are recorded on a separate magnetic tape and are added to the runoff values for the specific adjacent area during the gravity drain-pump analysis to provide total runoff inflow.

5. OUTPUT

The output generates a magnetic tape and printed record of all flood data for each day of gravity flow in the period of record. Contained in the information are the: year, month, day, rainfall, runoff, river stage, river elevation, outflow, and acres flooded. The printed record is checked for possible errors by Hydraulics personnel. The tape is used in the benefit analysis to compute flood damages with

and without the various improved facilities. The gravity drain is first optimized and, with this drain in place, the optimum pumping station is determined.

6. SUMMARY.

The program operates on a period of record type routing, making use of daily values of inflow, seasonal runoff coefficients, and outflow over the entire period of record. The program will evaluate up to five conditions of gravity drainage, pumping, ditching, and overflow into adjacent subareas. The program uses curves in coefficient form instead of tables, while making computations. The adequacy of existing gravity drains may be checked or new gravity outlets sized. The optimum capacity for a pump station may be determined. An optimum system of both gravity and pumping may also be computed. The program is currently running on an RCA 301 computer and requires about 8 to 12 hours of running time for a period of record of 60 years.

References

1. ASCE Hydrology Handbook, adopted January 1959, Chapter 3.
2. Handbook of Applied Hydrology, V. T. Chow, McGraw-Hill, 1964, Chapter 12.
3. TM-5-820-4, "Drainage for Areas Other than Airfields," Aug. 1964.
4. Handbook of Steel Drainage and Highway Construction Products (ARMCO Handbook), American Iron and Steel Institute, 1967, (pp. 83-141).
5. King's Handbook of Hydraulics, King and Brater, McGraw-Hill, 1963
6. Hydraulic Charts for Highway Culverts - U.S. Bureau of Public Roads, 1964.



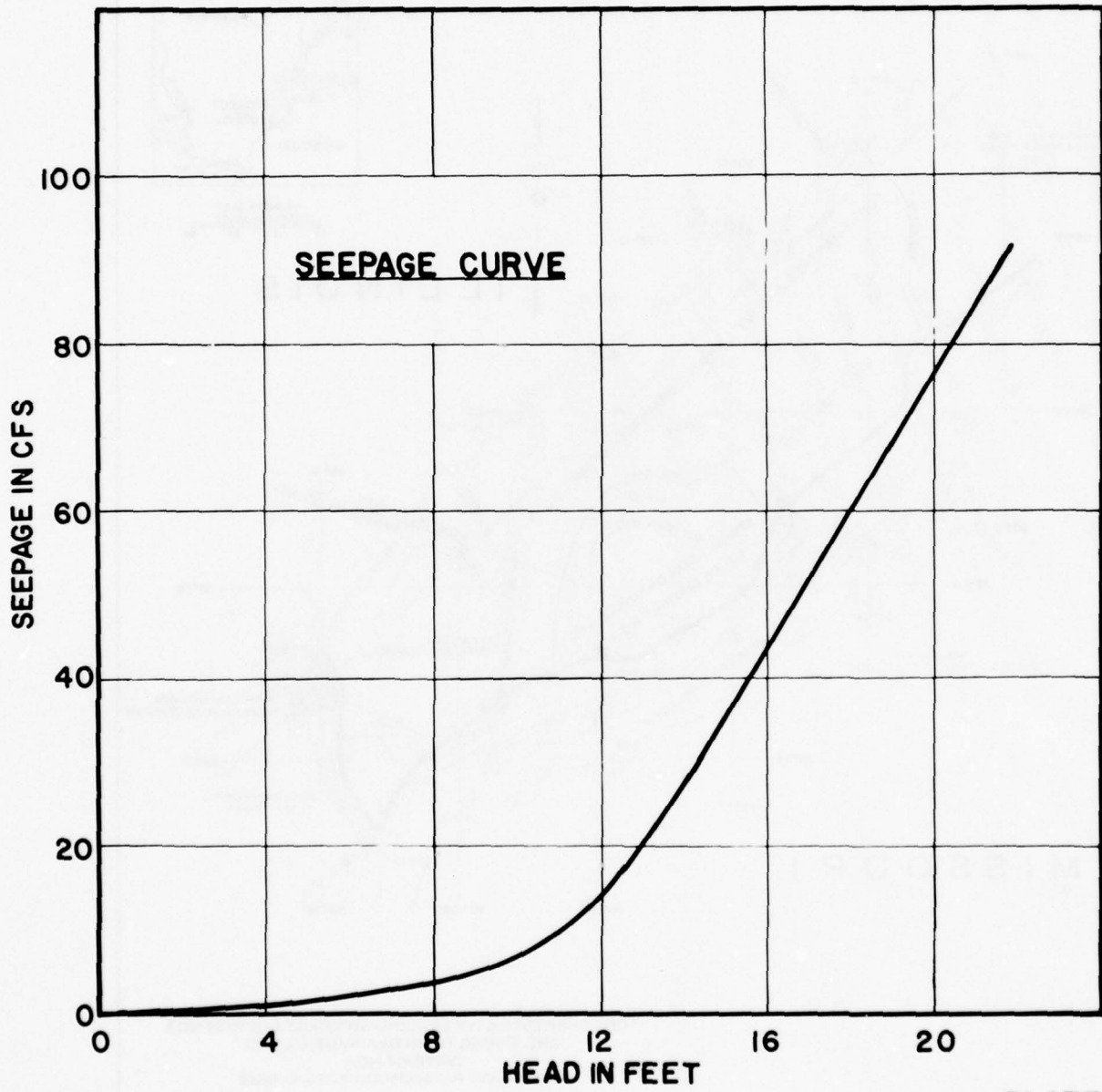
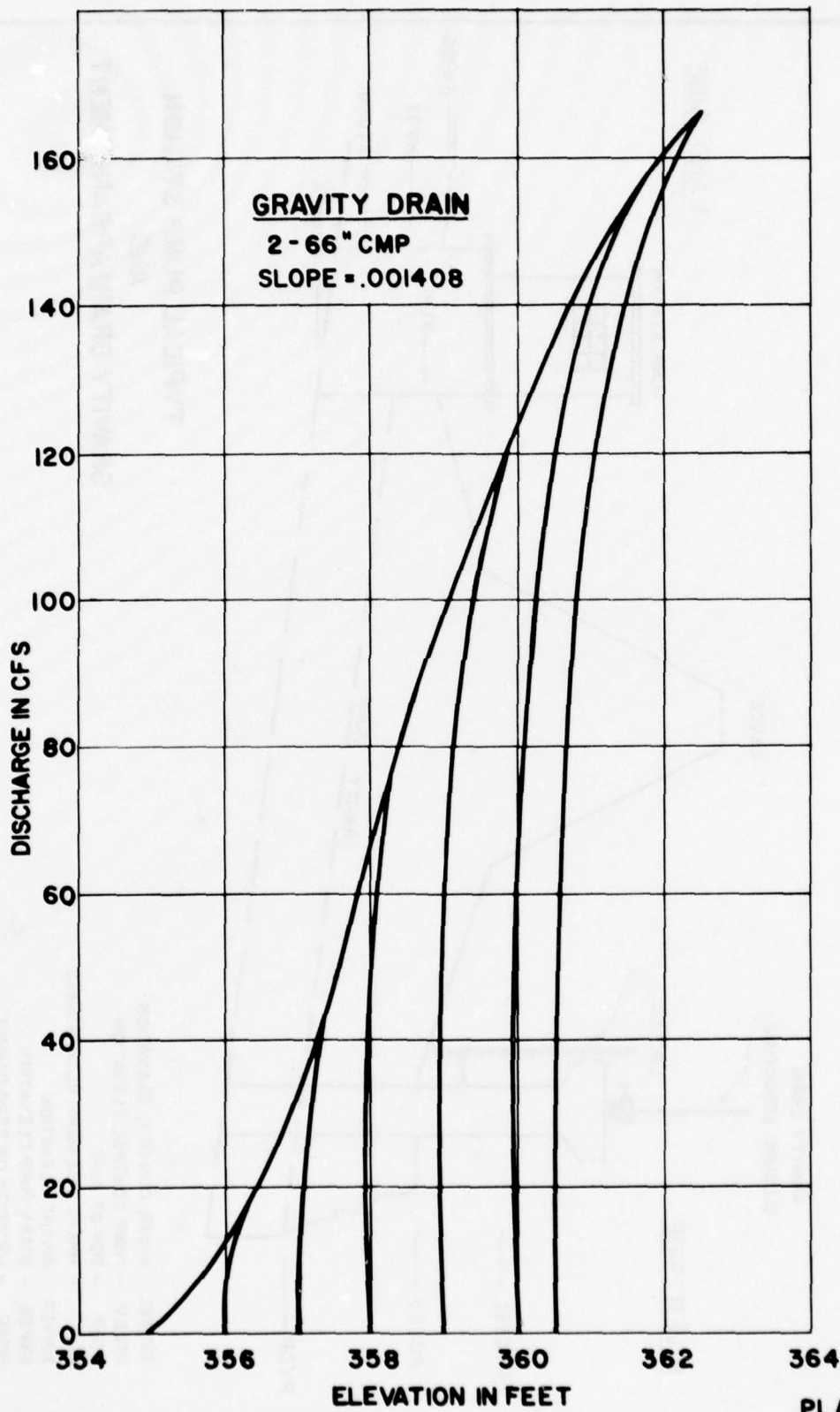
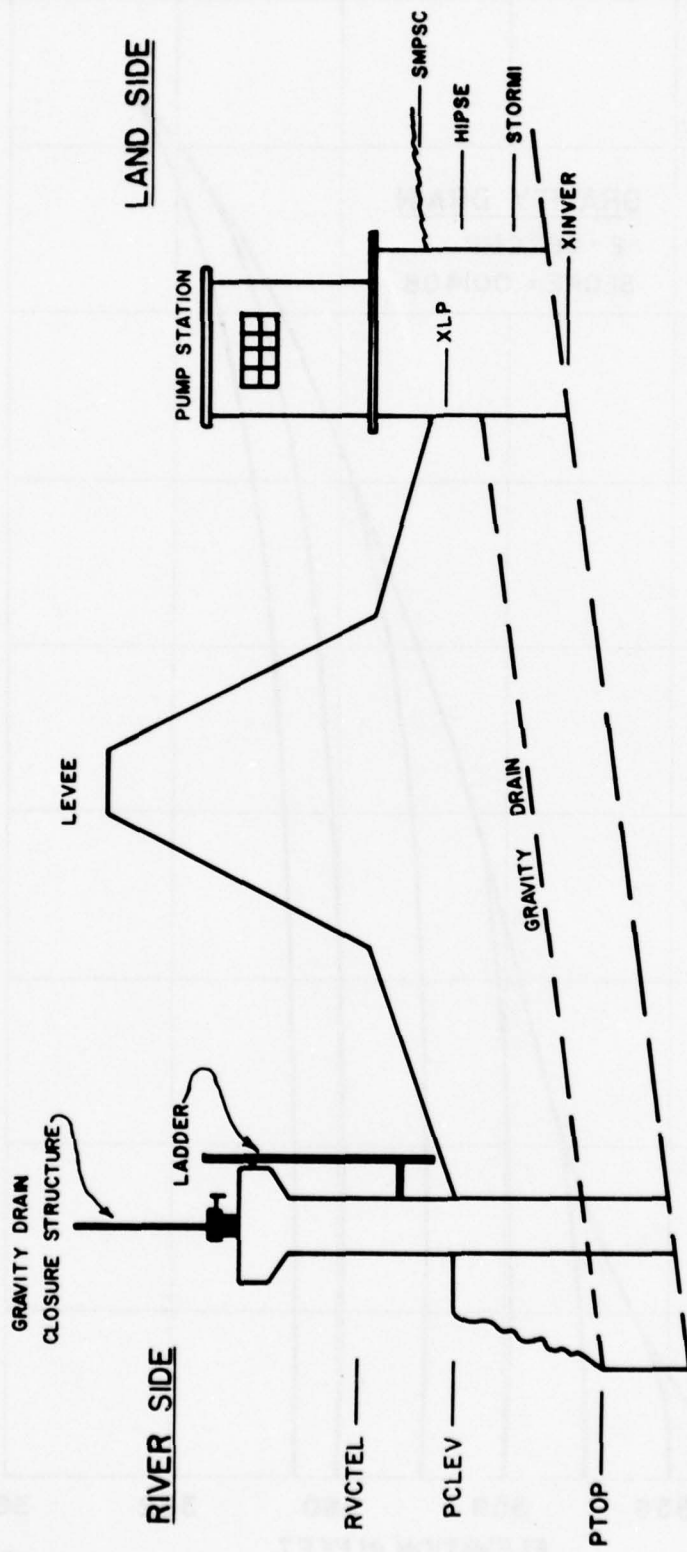

PLATE 2

2
SLK





**TYPICAL PUMP STATION
AND
GRAVITY DRAIN ARRANGEMENT**

- RVCTEL - RIVER CONTROL ELEVATION
- PCLEV - PUMP CONTROL ELEVATION
- PTOP - TOP OF PIPE
- XLP - WHERE PRESSURE FLOW STARTS
- XINVER - INVERT ELEVATION
- SMPSE - START PUMP ELEVATION
- HIPSE - LOCATION OF ZERO DAMAGE
- STORMI - STORAGE VALUE FOR LIMITS OF ROUTING

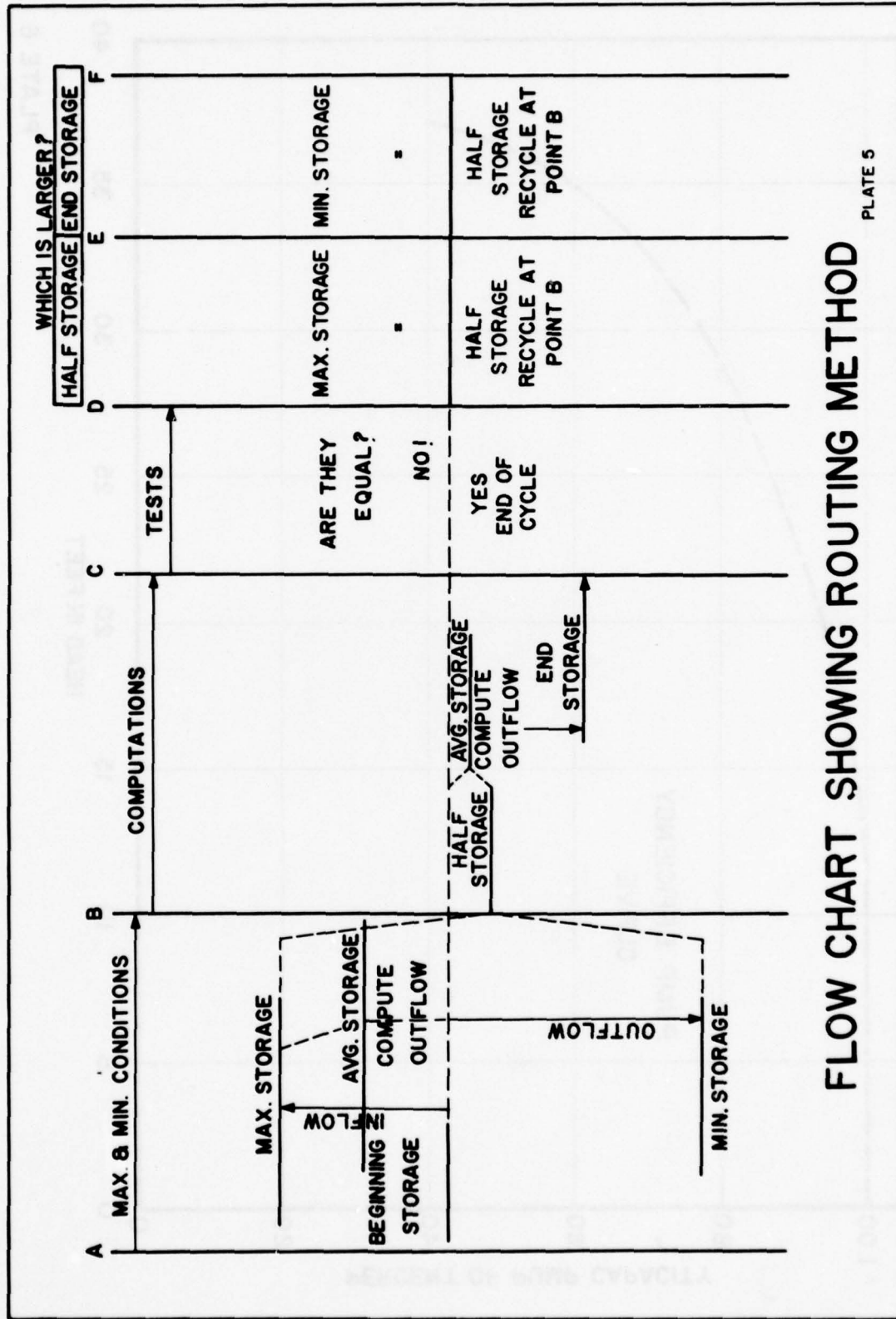

FLOW CHART SHOWING ROUTING METHOD

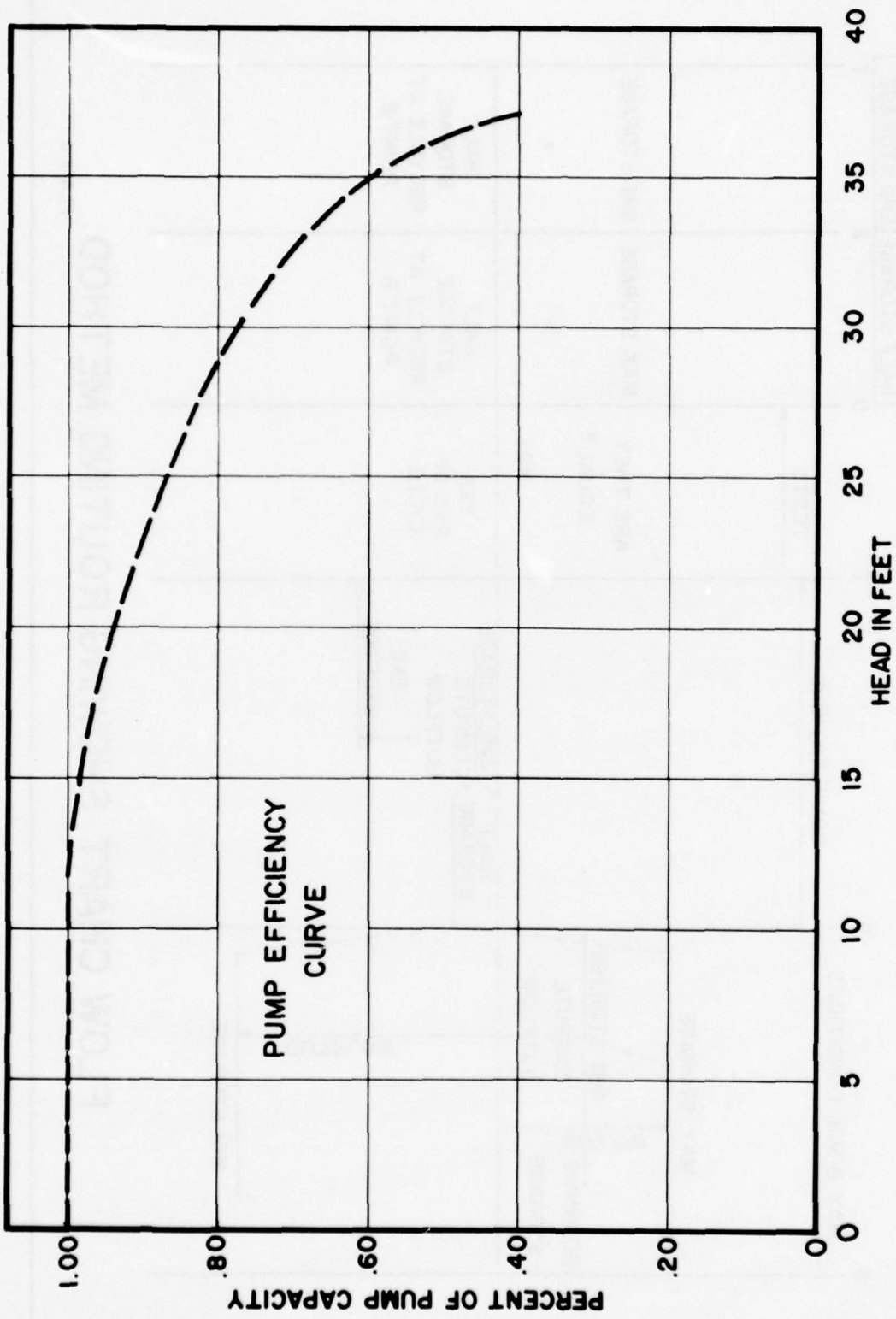

PLATE 6

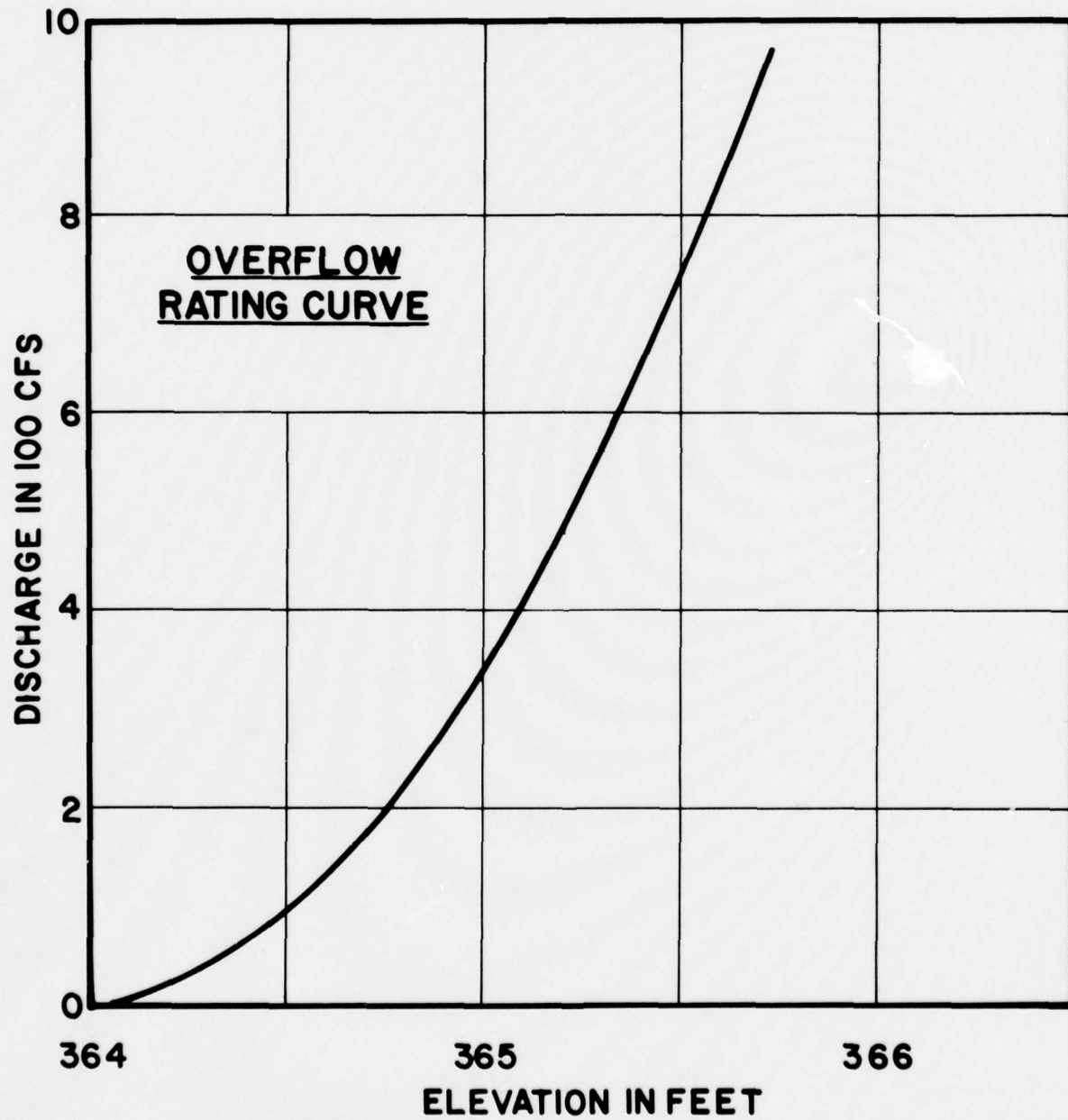

PLATE 7

COMPUTER APPLICATION FOR INTERIOR DRAINAGE STUDIES
ST. LOUIS DISTRICT

Discussion

Question, Mr. Beard: The program you describe simulates the operation of a specified interior drainage facility over many years of operation. Is there a need for optimizing the physical characteristics and operation rules of drainage facilities on the basis of costs and expected damages?

Reply, Mr. Curnutt: The operational costs have not been optimized up to the present time in our studies. Only the damage and the alleviation of damages for different sizes of pumping stations have been studied. This is not to say that the operational characteristics could not be used in the optimization studies in the future.

Question, Mr. Burnett: (1) Do you place the pump discharge line through the levee or over the levee? (2) Do you take any credit for siphon action through the pump discharge lines? (3) Outflow must be a small percent of inflow in order for daily routing to be accurate or else you have inflow which changes very little from day to day.

Reply, Mr. Curnutt: (1) The pump discharge line goes over the top of the levee in almost all cases. (2) No. None at all. (3) The outflow on any day can vary greatly. It can vary from the total capacity of the station and gravity drain to some percentage of the pump capacity. It could also equal zero. The amount of accuracy that will be achieved depends on the limit that is set in the program.

A Backwater Program for the
G.E. 225 Computer

by

William G. Westall¹

INTRODUCTION

The Computer program to be introduced in this paper is not original, but is a version of an early Hydrologic Engineering Center program entitled, "Backwater--Any Cross Section", dated June 1967. The modification was made in the St. Paul District Office of the Army Corps of Engineers, and was necessitated by the replacement of the District's IBM 1130 computer (to which the HEC program had been adapted) with a G.E. 225 computer.

The program for the G.E. 225 is limited in its abilities as compared to the original HEC program or its IBM 1130 adaptation, but should be adequate for the development of designs which in general conform to procedures and criteria outlined in the U.S. Army Corps of Engineers, Engineering Manual EM 1110-2-1601, 1 July 1970, "Hydraulic Design of Flood Control Channels".

ABOUT THE PROGRAM

General. There was a need for some editing of the HEC backwater program since all aspects of that program could not reasonably be adapted for use on the G.E. 225. There is also disagreement as to how some specific problems should be solved, and a generalized approach to some of these problems, particularly with respect to the computation of bridge losses, can not in all cases produce satisfactory results. The writer does agree with the idea of including flexible general solutions for as many different problems as possible in technical programs, but until there is specific criteria which governs the use of certain generalized methods, users of generalized programs might well be advised to be cautious. To avoid the problem altogether the G.E. 225 program, therefore, does not contain some of the generalized routines that are incorporated into the original HEC program.

¹Hydraulic Engineer, St. Paul District

Size and Form of Program. The G.E. 225 computer, for which the subject program is written, has an 8000 computer word memory, and the program which is written in FORTRAN II will fit this machine without the need for "chaining". Chaining is the process by which programs requiring more computer memory than is available on the G.E. 225 may still be adapted for use. To be more specific, if a large program is divided into a number of smaller subprograms or chains which individually can be handled by the computer, the chains can then be stored in sequence on tape and called into the computer as they are needed. The backwater program as modified was originally divided into four chains. The chains were then combined into one main program and five subroutines. The form is shown in Plate 1.

Method of Computation. The G.E. 225 program will compute water surface profiles for both subcritical and supercritical flow in either prismatic or irregular channels. The method of computation has not been changed from that in the original HEC program, and is similar to Method 1, as presented in the U.S. Army Corps of Engineers, Engineering Manual EM 1110-2-1409, 7 December 1959, "Backwater Curves in River Channels". The method of computation varies from Method 1 in that reach lengths between cross sections for overbank and channel flow need not be the same, shock loss due to expansion or contraction between sections is considered, and an attempt is made to compute the "true" velocity head at each section by considering Corioli's coefficient. A sample computation which would most closely represent the method of computation used by the computer program is shown in Plate 2.

Methods of Beginning. There are three methods by which a user may tell the computer what water surface elevation to use for beginning the backwater computation. The methods are the same as in the original program and are:

1. A known or estimated water surface elevation is provided by the user.

2. The water surface elevation is established by the computer using a slope-area method which requires a slope and an initial estimate of the water surface to be provided.

3. Critical energy will be computed and the corresponding water surface elevation will be used. An initial estimate of the water surface elevation should be provided.

A discharge and Manning's "n" values to be used for the first cross section must also be given to the computer.

Allowable Error. The allowable error of closure, which stops the iterations when computing backwater, must also be given to the computer before computations can proceed. When computing water surface elevations for subcritical flow with either the G.E. 225 or HEC program, allowable errors of .001 and .0001 appear to have little effect on the profile obtained as compared to the profile obtained using allowable errors of .05 or 0.1. The number of iterations is not significantly increased, however, when using the very small allowable errors. When computing profiles for supercritical flow, an allowable error of .001 to .0001 is desirable, particularly for very steep channels, because substantial error can be generated into the profile if large allowable errors are used. (See Ref. No. 6)

Abilities Retained. Most of the abilities of the HEC Program which apply directly to the backwatering process have been retained in the subject program. The specific items are listed and described briefly below and should be familiar to users of HEC programs.

1. If ice conditions are anticipated, wetted perimeter equal to the top width of the flow area will be added and included in the computation of the hydraulic radius. This procedure is an initialization process, however, and cannot be changed from section to section.

2. The computer will add 50 feet to the end elevations of each cross section unless another amount is specified. This process is also one of the initialization steps, and cannot be changed for each cross section.

3. Tables of "n" values can be established for each and every section which can be used to describe multiple roughness characteristics in the overbanks. The table is applicable only to the overbanks and not to the channel. The channel roughness can, however, be changed for each section.

4. Discharge changes can be made between sections to account for changes in flow due to decreasing or increasing tributary area.

5. The shock loss coefficients for expansion and contraction can be changed from section to section.

6. The computer will correct for ineffective area in the overbanks if desired. This step is not automatic but must be indicated for each section where the correction is to be made.

7. The computer will calculate the critical water surface elevation, and provide a check to insure that the water surface elevation computed during backwater operations remains on the

proper side of critical. Critical depth will be assumed when the computed water surface elevation is on the wrong side of critical. By an initialization step critical depth may be computed for all cross sections, but if desired critical depth may be computed only for specifically selected sections. The G.E. 225 program varies slightly from the HEC program in that critical depth will not be automatically assumed if computational problems are encountered by the computer, but will stop computing at the point of difficulty and print the appropriate note. This variation applies principally when the number of iterations for balancing the water surface elevation exceeds 20 iterations.

Estimating the Water Surface Elevation for the Next Section.

There are two methods for estimating the water surface elevation for the next section. The first method is the one used by the HEC program, and is good for channels that have regular bottom slopes. This method takes the depth calculated for the previous section, adds it to the bottom elevation of the next section, and uses the resulting water surface elevation as the first estimate to begin the iteration process. There may be problems encountered with this method if the channel bottom is irregular and the elevations for the profile to be computed are near critical for each cross section.

The second method available on the G.E. 225 program is not available on the HEC program and is considered by the writer to be an improvement over the first method discussed. The second method uses the slope of the water surface profile computed between the previous two sections for estimating the water surface elevation for the next section. This method is particularly good for computing profiles which start by critical depth and stay close to critical throughout the channel reach for which the profile is to be computed. The second section must by necessity be very close to the first section when starting by critical depth. The depth method must be used for the first estimate of the water surface for the second section because no water surface slope has been established until the water surface elevation of the second section has been computed. Once the water surface slope has been computed, however, succeeding first estimates are guaranteed to be on the proper side of critical by the very nature of water surface profiles which began at critical depth. This fact is true for both subcritical and supercritical flow. Computational problems involving the critical depth check or the inability to balance through the iteration process can be more easily overcome if the slope method is used since the insertion of intermediate sections often solves the problem.

Bridge Routines. The following bridge routines are available in the G.E. 225 program:

1. Losses for class A & B flow can be calculated by the Yarnell Energy Method. Class C flow cannot be handled.
2. Upstream and downstream surface elevations can be calculated

for orifice type flow.

3. Normal backwater can be used for flows below the low chord of the bridge.

4. A loss computed or estimated independently by the user may be added into the profile at the bridge section without the need for stopping the computation.

There is no provision for considering weir flow at a bridge, however, for flows below the low chord of the bridge normal backwater procedures (which correspond to the normal bridge routine in the HEC program) may be used to estimate the water surface profile through the bridge and over the approach roads. In the writer's opinion, assuming that weir flow exists at every approach road embankment when the upstream water surface elevation is above the roadway elevation is a generalization which cannot always be trusted. The flow situation around and through a bridge is not a simple two dimensional phenomena, especially in cases where the approach road is overtopped some distance from the bridge. If the roadway embankment acting as a weir can discharge by a substantial amount more flow than can be carried by the overbank or than can be supplied to the overbank by the channel, than the effect of the road embankment is something other than that of a weir.

One approach to the problem would be to subtract the overbank flow from the total flow and compute the loss as that which the bridge structure effects on the channel flow alone. The writer does acknowledge that weir flow may exist in cases where overtopping of the road occurs close to the channel or at the bridge, but more criteria is needed before the concept should be applied in all cases.

Other Modifications. The HEC program has the ability to interpolate intermediate cross sections when the change in velocity head between given sections exceeds a specified amount. To include this ability in the G.E. 225 program was unreasonable, but notes indicating the need for additional sections are printed for informational value to the user.

There is an error routine for the subject program that prints error messages which are more complete than the notes printed by the HEC program. The output format has also been changed in the program and a sample is shown in Plate 3.

SUMMARY

The program for the G.E. 225 as presented should be rather useful in offices where access to very large computers is limited. As written, the program should be easy to modify to other computers similar in size to the G.E. 225. The form of the program should inspire numerous ideas for routines which can be added to expand

the program's capabilities. Three of the subroutines can be made into separate chains without any significant increase in the run time. The subroutines START, ABRID, and AERR are self contained and calculate or print what is desired of them without cycling back and forth to the main program. When these routines are made into chains, considerable memory space is available for adding routines which solve other problems that are relative to the computation of water surface profiles.

REFERENCES

1. U.S. Army Corps of Engineers, Engineering Manual EM 1110-2-1601, "Hydraulic Design of Flood Control Channels", 1 July 1970.
2. U.S. Army Corps of Engineers, Engineering Manual EM 1110-2-1409, "Backwater Curves in River Channels", 7 December 1959.
3. U.S. Army Corps of Engineers, Hydrologic Engineering Center, "Backwater--Any Cross Section", June 1967.
4. U.S. Army Corps of Engineers, Hydrologic Engineering Center, "HEC 2 Water Surface Profiles", December 1968.
5. Eichert, Bill S., "Survey of Programs for Water-Surface Profiles", Journal of the Hydraulics Division, ASCE, Vol. 96, No. HY2, Proc. Paper 7098, February 1970.
6. Prasad, Ramanand, Discussion of (5) Journal of the Hydraulics Division, ASCE, Vol. 96, No. HY11, November 1970.
7. Eichert, Bill S., and Peters, John, "Computer Determination of Flow Through Bridges", Journal of the Hydraulics Division, ASCE, Vol. 96, No. HY7, July 1970.
8. U.S. Army Corps of Engineers, Hydrologic Engineering Center, HEC Training Document "Water Surface Profiles", Preliminary, February 1969.

FORM OF BACKWATER PROGRAM

FOR G. E. 225

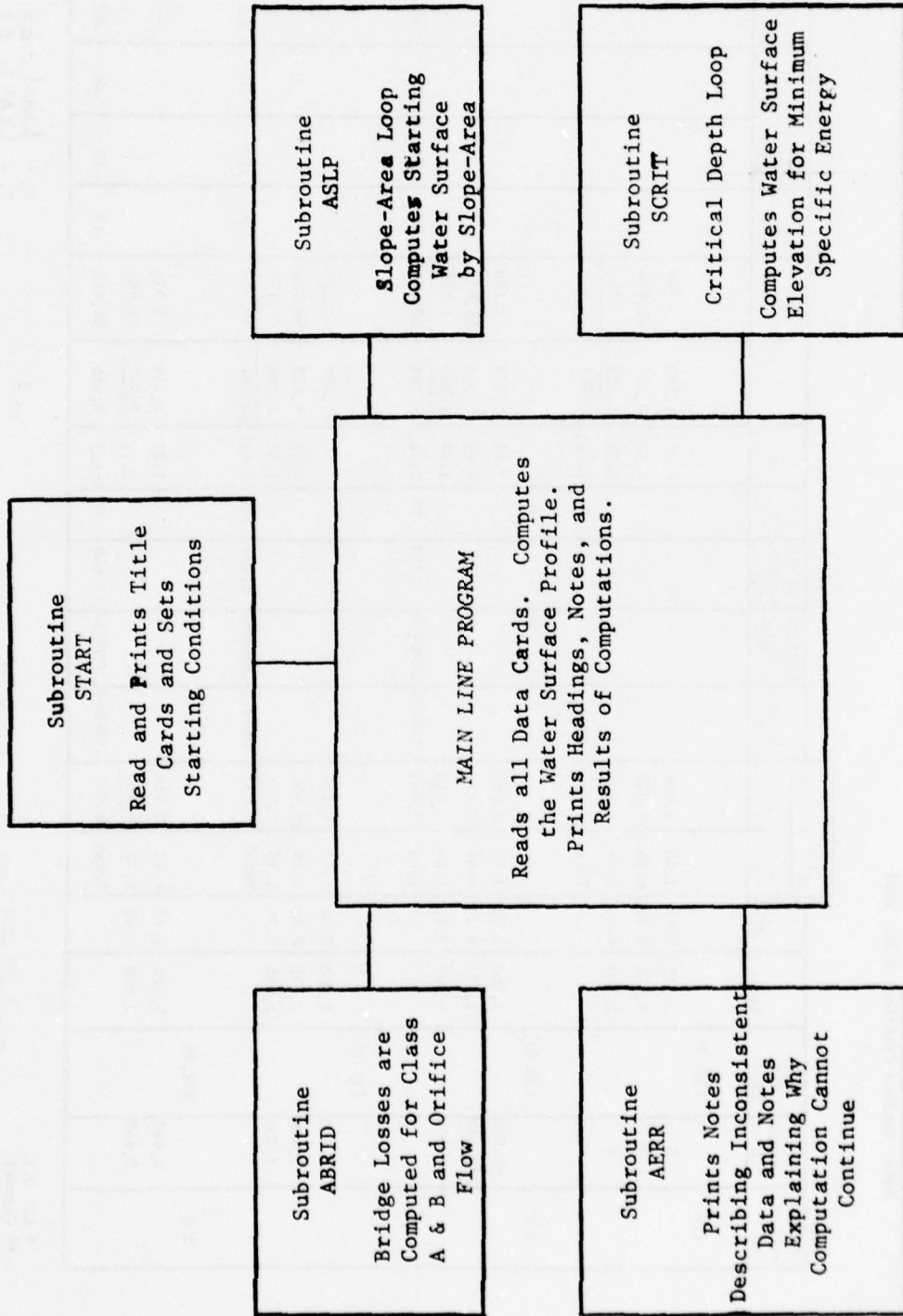

EXAMPLE OF BACKWATER COMPUTATION
AS DONE BY COMPUTER

Note: Numbers were taken from Preliminary HEC Training Document - Water Surface Profiles, 5 Feb 1969

Note: Capital letters for Q and V denote totals for section.

Mile or Sec. No.	Reach Length L	Est. M.S. Elev.	Area	r ^{2/3}	S ^{1/2} = 0.01		Slope S	Average S _{avg}	W'd Length L _{wf}	h _f	v	q	v ² q	h _v	h _v - h _{v2} / Δh	h _s	H	Comp. M.S. Elev.
					v ₀₁	q ₀₁												
1.0	0	132.70	1,589	6.63	2.46	3,909					0.78	1,239	754					
	0		3,924	9.20	6.86	26,840					2.17	8,515	40,096					
	0		1,589	6.63	2.46	3,909					0.78	1,239	754					
				Total	34,658		.00001					Total	10,993	41,604	.06			
1.5		132.80																
	*2,000		1,068	5.72	1.89	2,019					1.01	1,079	1,100					
	**2,640		3,197	8.23	4.89	15,633					2.61	8,344	56,823					
	***2,950		1,068	5.72	1.89	2,019					1.01	1,079	1,100					
			Total	19,671		.000028		2,760	.05	Total	10,502	59,023	.09				.03	132.73
2.0		132.75																
	2,000		1,065	5.74	1.90	2,024					1.02	1,086	1,129					
	2,640		3,191	8.22	4.89	15,604					2.61	8,329	56,720					
	2,950		1,065	5.74	1.90	2,024					1.02	1,086	1,129					
			Total	19,652		.000029		2,606	.05	Total	10,501	58,978	.09				.03	132.73
2.0		132.80																
	2,640		1,920	4.93	1.83	3,514					1.27	2,438	3,932					
	2,640		2,280	6.41	4.76	10,853					3.31	7,547	82,686					
			Total	14,367		.000048		2,640	.10	Total	9,985	86,618	.13				.07	132.80

$$h_s = |.3\Delta h|, \Delta h = (-)$$

$$h_s = |.1\Delta h|, \Delta h = (+)$$

$$H = \Delta h + h_f + h_s$$

$$H = \Delta h + h_f + h_s$$

$$v = \frac{v_{01} Q}{\sum v^2 q}$$

$$h_v = \frac{64.4 Q}{\sum v^2 q}$$

$$L_{wt} = \frac{\sum q_{01} L}{q_{01}}$$

$$h_f = S_{avg} \times L_{wt}$$

$$v_{01} = \frac{1.486}{n} r^{2/3} (.01)$$

$$S = \left[\frac{0.01 \cdot Q}{C_{01}} \right]^2$$

* Lt. O.P.
** Channel
*** Rt. O.P.

CHIPPEWA RIVER
 WATER SURFACE PROFILE FOR
 100-YEAR FLOOD-Q=131,000 CFS
 AT EAU CLAIRE, WIS.
 LOW FLOW CONDITIONS AT BRIDGE

STARTING CONDITIONS

COEF CONT EXP WSEL ALL-ERR LT BK RT BK CHAN -N- -N- -N- CHANGE
 0.300 0.500 0.100 0.030 0.060 0.029 0.50
 HV-ALLOW

START BY KNOWN W S

WATER SURFACE EL DISCHARGE
 775.200 131000.

USE SLOPE OF WATER SURFACE PROFILE FOR
 ESTIMATING W.S. FOR NEXT CROSS SECTION

SECTION NO.	W.S. ELEVATION	WSEL	ALOR	ACH	AROR	FG	ELMIN	LOBL
		CMSEL	VLOB	VCH	VRJB	HV	TOPWID	CHL
		CHWS	XNL	XNCH	XNR	HL	SLOPE	ROBL
		Q	ULOR	QCH	QROR	OTHER LOSS	TRIAL	CIRIAL
DIVIDED FLOW								
CROSS SECTION EXTENDED	4.70 FEET							
2.00	775.20	775.20	1903.	15062.	2481.	776.21	743.80	0.
		775.20	1.23	8.26	1.74	1.01	1394.28	0.
		762.70	0.080	0.029	0.080	0.00	0.000000	0.
		131000.	2334.	124353.	4312.	0.00	0.	10

TABLE OF N VALUES FOR X-SECT.

DIVIDED FLOW	W.S. ELEVATION	WSEL	ALOR	ACH	AROR	FG	ELMIN	LOBL
		CMSEL	VLOB	VCH	VRJB	HV	TOPWID	CHL
		CHWS	XNL	XNCH	XNR	HL	SLOPE	ROBL
		Q	ULOR	QCH	QROR	OTHER LOSS	TRIAL	CIRIAL
DIVIDED FLOW								
3.00	775.70	775.67	32.	13365.	14618.	776.48	730.00	860.
		775.67	0.17	7.95	1.69	0.80	3020.28	670.
		0.00	0.080	0.029	0.100	0.21	0.000706	260.
		131000.	5.	106259.	24736.	0.06	2.	0

A BACKWATER PROGRAM FOR THE GE-225 COMPUTER

Discussion

Comment, Mr. Fredrich: The types of discrepancies being discussed are not what would be considered programming errors and therefore would not be detected by a detailed examination of the coding. The discrepancies are due to assumptions and criteria inherent in the method that are not consistent with the physical conditions obtained in the particular application at hand. These discrepancies are only discovered by a somewhat comprehensive and detailed understanding of both the program logic and the problem itself.

Reply, Mr. Westall: Many of the problems encountered which are of the type mentioned above were corrected by eliminating or limiting the particular option in which the problem was encountered. The bridge routines and interpolated section routine are examples. A detailed and comprehensive study of the original HEC program was felt to be outside the scope of the intended purpose of the modification. The intended purpose was to provide a program which would handle most of our design problems and not to provide comprehensive corrections to the HEC program.

Question, Mr. Curnutt: What is the approximate running time per cross-section in this program?

Reply, Mr. Westall: The run time per cross section is dependent upon the number of points in the cross section and the options used at the cross section. The run time will vary from 5 seconds per section in a simple prismatic channel to 40 seconds per section in a natural channel with complex sections. The average run time would generally be about 15 to 20 seconds per section.

Question, Mr. Eichert: How much development time and money were required to convert the HEC backwater program from use on the IBM 1130 to the GE 225?

Reply, Mr. Westall: To develop a program that would compute the water surface profile took about 3 weeks. This development was done by two GS-11's working mostly on overtime (which is cheaper than regular time). The rest of the development was done partly in conjunction with actual design projects but mostly in connection with this paper which cost the government little except in the way of computer time and the time associated with the monitoring of the output. The exact cost is unknown since it was spread out in different overhead items.

Question, Mr. Eichert: Why didn't the District rent computer time to use the HEC backwater program instead of modifying it to be used on the GE 225?

Reply, Mr. Westall: The general feeling was that the District should develop the ability to utilize its own equipment in all phases of its mission and that the ability should be developed as quickly as possible. Small amounts of time were rented on an IBM 1130 to be utilized when absolutely necessary and to allow for time to make the necessary modifications in existing programs. Although HEC-2 was available on the University of Minnesota's CDC 6600, no one in the District had actually used HEC-2. The users of the IBM 1130 backwater program felt that there was a certain amount of mystery associated with the program they had and that to proceed to a larger more complicated program would add to their design problems rather than alleviate them.

Comment, Mr. Matthews: Time spent in modifying the HEC program could have been decreased by consulting with HEC when problems appeared. Tests should be run at difficult points.

Reply, Mr. Westall: The HEC program was documented fairly well in that the variable names and the variable functions in the program were well defined. The modification was actually fairly easy and no large problems were encountered. The Hydrologic Engineering Center would have been consulted if problems which we could not understand did appear.

The program was tested initially with the test data given in the HEC documentation of the original program. Testing was completed by running actual design problems which had been done originally on the IBM 1130. Since the testing period, four large designs have been completed using the program and no problems with the program were encountered.

Comment, Mr. Fredrich: I don't think that what you have described as your ignorance should rightfully be called ignorance. The problems you described are the problems one might anticipate any technically competent user to encounter in using a generalized program with which he is only generally familiar. Until perfect documentation is developed, we must depend on the users' experience for evaluation of the validity of results and to determine how to use the program to obtain the required results.

Reply, Mr. Westall: When I said that most of our problems with the original HEC program stemmed from our own ignorance I was referring primarily to the details of the method of computation and the program logic within the program rather than to technical competence. However, lack of technical competence may have played a part in some cases. Remaining technically competent is rather difficult when using a

computer program in lieu of hand computations because gaining "the feeling" for a problem is more difficult and may be completely lost in the pressing need to get out the report.

Comment, Mr. Eichert: The HEC does offer training in the use of our generalized computer programs. We offer this training in our formal training courses and in special courses given at the request of the District offices and in individual training assignments to the Center which are also requested by the District offices.

Reply, Mr. Westall: When the Districts have developed their computer capabilities more fully, formal and individual training would be needed. At the present, however, all the training could not necessarily be put to immediate use, and could become stale before it is used.

Comment, Mr. Peters: I'd like to ask Tony Thomas to pursue his comments with regard to making use of someone else's computer program. Tony, what would you do to convince yourself that a program does or does not meet your needs and is doing what it's supposed to do?

Reply, Mr. Thomas: From the program abstract and documentation, assuming that hardware and software requirements can be satisfied, one can judge whether or not the program merits more detailed consideration.

My next step is to investigate the type and amount of input data required. If my problem can be described without excessive simplification, the investigation is shifted to the computation algorithms. It is not sufficient to rely upon theory formulated in the program document when numerical integration, differentiation and interpolation techniques are involved. Understanding how the FORTRAN logic handles these techniques is important. Occasionally the basic theory can be modified to incorporate the desired capability.

Test problems that accompany the program are processed, but also new test problems are formulated. These are simple and small in scope, but are designed to test extreme events. Variables defined by input data are set to zero or to a very large value for some cases. Problems for which solutions are available are analyzed. It is important for the user to develop confidence so that he can tell when the program is not performing properly.

HYDRAULIC TRANSIENTS IN THE TVA SYSTEM OF RIVERS AND RESERVOIRS

James T. Price¹

INTRODUCTION

The operation of the water control and hydro power generating facilities of the TVA system causes a continuously varying movement of the waters in the separate reservoirs and connecting river links which make up this system. Research efforts over the past several years have led to the development of a computer solved mathematical model which accurately describes this movement of the water in a reservoir or river link as it responds to the multipurpose operations of the facilities bounding the reservoir or river link. These water release operations may be as sudden as the near instantaneous come-on and shutdown of the turbines during power peaking or as gradual as the passage of floodwaters through the control structures or any combination thereof.

This paper describes the application of a computerized mathematical model to a variety of complex transient flow problems associated with the TVA system of rivers and reservoirs.

The Mathematical Model

The mathematical model for unsteady flows in open channels is one dimensional in that it considers flow characteristics such as depth and velocity to vary only in the longitudinal (x) direction and with time. The channel geometry is three-dimensional. The two equations of one dimensional unsteady flow, the continuity equation and the equation of motion are:

$$\frac{\partial(AV)}{\partial x} + B \frac{\partial H}{\partial t} = q \quad (1)$$

$$g \frac{\partial H}{\partial x} + V \frac{\partial V}{\partial x} + \frac{\partial V}{\partial t} + g \frac{n^2 V |V|}{2.21 R_H^{4/3}} + \frac{q}{A} V = 0 \quad (2)$$

1. Hydraulic Specialist and Head, Unsteady Flow Staff, Flood Control Branch, TVA, Knoxville, Tennessee.

Where A is flow area, B is surface width, V is velocity, x is distance, H is water surface elevation, t is time, q is lateral inflow per unit distance and time, g is the gravity constant, n is Mannings coefficient, and R_H is the hydraulic radius. TVA is using a centered difference net (1)* to solve equations 1 and 2. This net is stable and convergent if the following relation is satisfied.(2)

$$\left(V + \sqrt{g \frac{A}{B}} \right) \frac{\Delta t}{\Delta x} \leq 1 - g \frac{n^2 |V|}{2.21 R_H^{4/3}} \Delta t \quad (3)$$

in which Δt and Δx are the computational net dimensions. Off-channel storage is accounted for by adjusting the width B in the equation of continuity to give the correct volume of the water body at a particular elevation. Stage, flow, or rating curve boundary conditions, local inflows, variable roughness along the channel, and actual channel geometry can be used. Steady or transient flows and stages along the channel may be given for initial conditions. The computer output from the solution of the mathematical model may be obtained in either tabular or graphical form, for any set of desired locations and times. An IBM system 360, model 50, or an equivalent system, is required to accommodate the program used by TVA.

Model Verification

The validity of mathematical modeling rests upon the ability of the model to reproduce, within a study reach, actual transient conditions which have occurred in response to known time varying boundary conditions of stage and/or discharge or velocity. For a controlled river such as the Tennessee these model verification data are readily available from the records required for the daily multipurpose operations of the system. These necessary data may also be obtained by special field tests.

That the model accurately reflects the water behavior in response to the operations involved, is illustrated by the following examples.

Browns Ferry Nuclear Generating Plant Study--This plant is located on Wheeler Reservoir in which transient flow conditions continuously occur because of the intermittent hydropower operations of the turbines located at the upstream and downstream boundaries of the reservoir. Water required for condenser cooling purposes at the Browns Ferry Plant will be

*Numbers in parentheses refer to references on page 6.

withdrawn from and returned with an elevated temperature to this reservoir in which flow conditions are continuously changing. These cooling water facilities must therefore be so designed as to meet the established water quality standards for the area and to prevent recirculation of these heated waters back through the cooling system. Consequently, a thorough knowledge of Wheeler Reservoir transient flow conditions was one basic need to the effective design of these cooling water facilities. Plate 1 illustrates the excellent model verification achieved in this study (3, 4, 5) using field measurements of continuously varying velocity and stage measured at the Browns Ferry site.

Sequoyah Nuclear Plant Study--Design of the cooling water facilities for this plant again dictated that the transient water behavior in response to the intermittent turbine operations of the upstream and downstream dams be understood. This study (5) is cited because the model verification was achieved using field velocity data taken from a specially arranged steady flow field test. Plate 2 shows the excellent agreement between computed and observed quantities both at the site and at several other locations within Chickamauga Reservoir.

Cumberland River Study--This study (4, 5), a joint effort among TVA, Corps of Engineers, and USGS, was designed to shed some light on how power peaking releases from Barkley Dam during low stages on the Ohio River affected navigation conditions in the narrow, winding Cumberland River. Plate 3 compares the computed and observed stages at selected stations along the Cumberland. Again the agreement is excellent. The sensitivity of the model is seen by noting the small blips on the stage some 11 miles downstream from Barkley Dam. These were caused by locking operations made during these turbine releases. Observed upper depth navigation channel velocities are compared with the mean channel velocity (Q/A) on Plate 4.

Kentucky-Barkley Canal Study--TVA's Kentucky and the Corps of Engineers' Barkley Lakes are linked together by an uncontrolled navigation canal. The magnitude and direction of the flow in this canal is determined by the head difference which exists between the canal ends. Because both these lakes are subject to intermittent power operations, this head difference, though small, is continuously varying. Consequently, there is a continuous flow interchange between these two water bodies. Plate 5 (4, 5) illustrates the use of the model to determine canal discharge using the stage at the canal ends as boundary conditions. This figure also contrasts two field discharge measurements with model results. One measurement is good, the other poor.

Model Applications

The foregoing examples have been presented to illustrate that the model will indeed reproduce known historical transient flow events. Because of this, it can now be used with faith to predict transient flow conditions which will occur for nearly all other types of anticipated operations or conditions.

Guntersville Reservoir: Maximum Possible Flood--Nuclear plant siting studies and licensing procedures require that extreme flood elevations be determined at the plant sites. Plate 6 shows the elevations and discharges which will occur in Guntersville Reservoir at several possible site locations during the passage of this extreme flood. Also shown is the effect of an assumed sudden failure of the dam at the upstream reservoir boundary coupled with the passage of this flood.

Raccoon Mountain Pumped Storage Study--TVA is constructing a pumped storage generating station on Nickajack Reservoir. Water will be released into the reservoir during generation and withdrawn from the reservoir during pumping operations. Plate 7 (4) illustrates schematically these releases and withdrawals to and from the reservoir. These effects needed to be evaluated in order to assess how these operations might affect navigation past the location of the intake-outlet structure. In order to adequately design the intake-outlet structure, hydraulic model studies are being made to assure proper structure performance. The mathematical model was used to predict the overall reservoir transients which will result from the operation of the turbines at the upstream and downstream boundaries of Nickajack Reservoir coupled with the operation of the Raccoon Mountain station. Plate 8 shows these transients at selected locations. In order to properly operate the hydraulic model which extends approximately 1/2 mile above and below the intake-outlet structure, transient flow conditions must be known at the hydraulic model boundaries. To accomplish this, the reservoir mathematical model was used to give transient boundary conditions for still another mathematical model extending some 4 miles on either side of the intake-outlet structure. This 8-mile long mathematical model used finely divided Δx spacing to yield the transients which will occur at the boundaries of the hydraulic model. Plate 9 illustrates the results obtained using this secondary model.

Model Input Separation Technique--Plate 10 shows for the Sequoyah Nuclear Plant study the transient flow conditions which occurred at the plant site in response to the actual turbine operations at the upstream and downstream boundaries of the reservoir. Plate 10 also shows the transients caused by assuming respectively, only downstream boundary turbines operating, only upstream boundary turbines operating, and local

inflow alone. These "separately" caused transients are then added algebraically and compared to the real case in which these transients occur simultaneously. While not precisely correct, this technique does permit identifying these separated operations with the effect each produces at any point along the water course. Thus, the additive characteristics of these translatory waves may be exploited to arithmetically or graphically approximate a composite transient behavior. This suggests that by simple phase-shifting a wide variety of operations can be investigated coarsely from a few computer runs.

Conclusions

Once verified, the model may be used with complete confidence to predict transient flow behavior for a variety of complex unsteady flow behavior. The model thus becomes an invaluable water management tool. With the continued and increased emphasis being placed on maintaining and improving our water resources through better water quantity and quality management practices, the ability to trace transient water behavior becomes the key for attacking the more complex problems of water transport. It is these continuously moving waters which transport life-sustaining dissolved oxygen, the heated effluent from nuclear and conventional generating plants, and pollutants of all types from industrial and municipal sources. Such a mathematical model is the only method available which provides the detailed spatial and temporal data on water movement necessary to attack the more complex environmental problems relating to the water transport of dissolved oxygen, heat from thermal sources, etc.

References

1. Stoker, J. J., "Numerical Solution of Flood Prediction and River Regulation, Report I," Report IMM-NYU 200, New York University, October 1953.
2. Perkins, F. E., "The Role of Damping in the Stability of Finite Difference Techniques," ASCE National Meeting on Environmental Engineering, Meeting Preprint 689, Chattanooga, Tennessee, May 13-17, 1968.
3. Buehler, B. J., Price, J. T., and Garrison, J. M., "Transient Flow Investigations for TVA's Browns Ferry Generating Station," Proceedings, 7th Annual Sanitary and Water Resources Engineering Conference, Vanderbilt University, Nashville, Tennessee, May 1968.
4. Garrison, J. M., Granju, J. P., and Price, J. T., "Unsteady Flow Simulation in Rivers and Reservoirs," Proceedings A.S.C.E., Journal of the Hydraulics Division, September 1969.
5. Buehler, B. J., Garrison, J. M., Granju, J. P., and Price, J. T., "Digital Computer Simulation of Transient Flows in the TVA System," Proceedings XIII Congress I.A.H.R., Kyoto, Japan, September 1969.

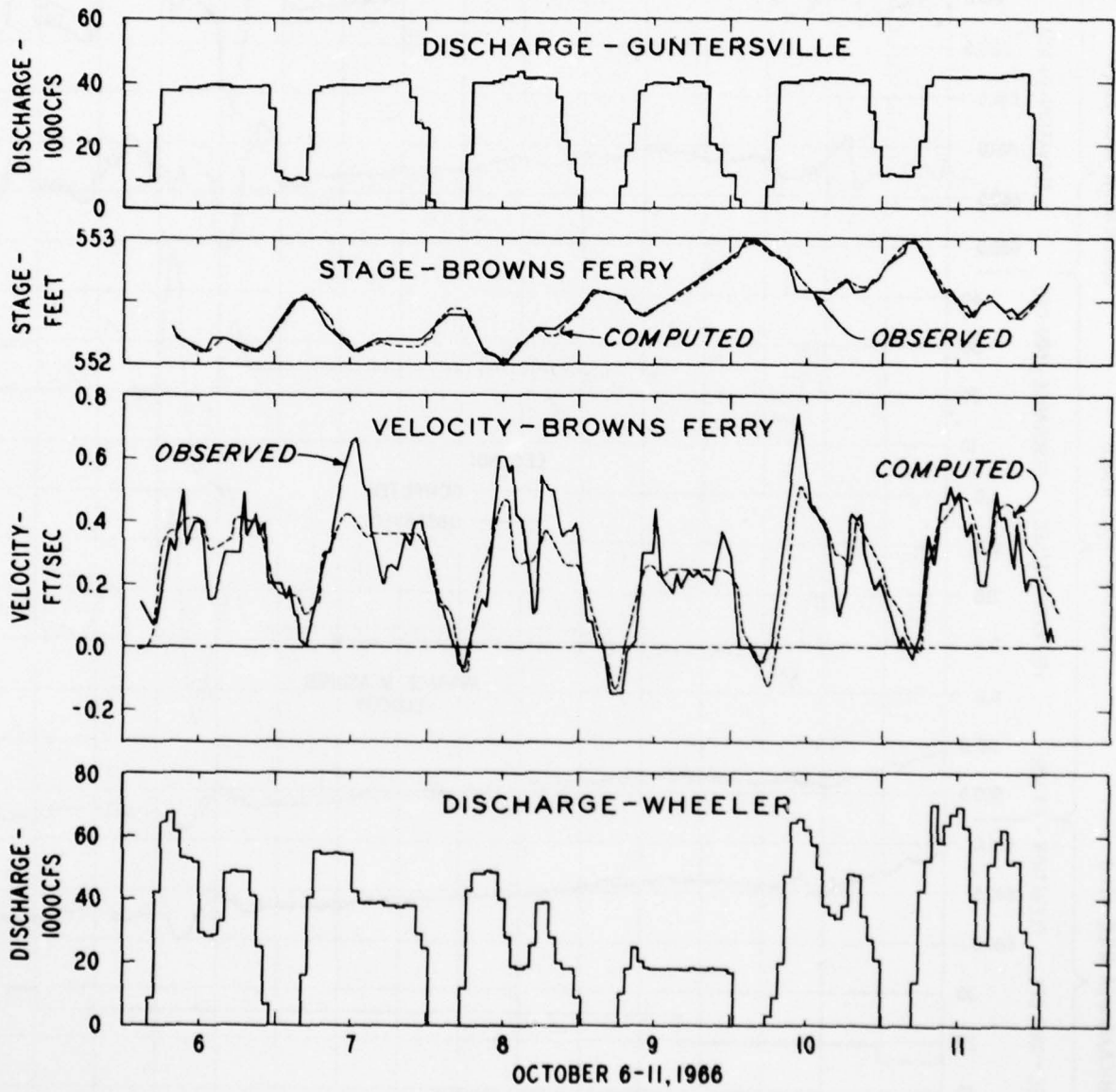

BROWNS FERRY STUDY

COMPUTED AND MEASURED QUANTITIES AT BROWNS FERRY SITE

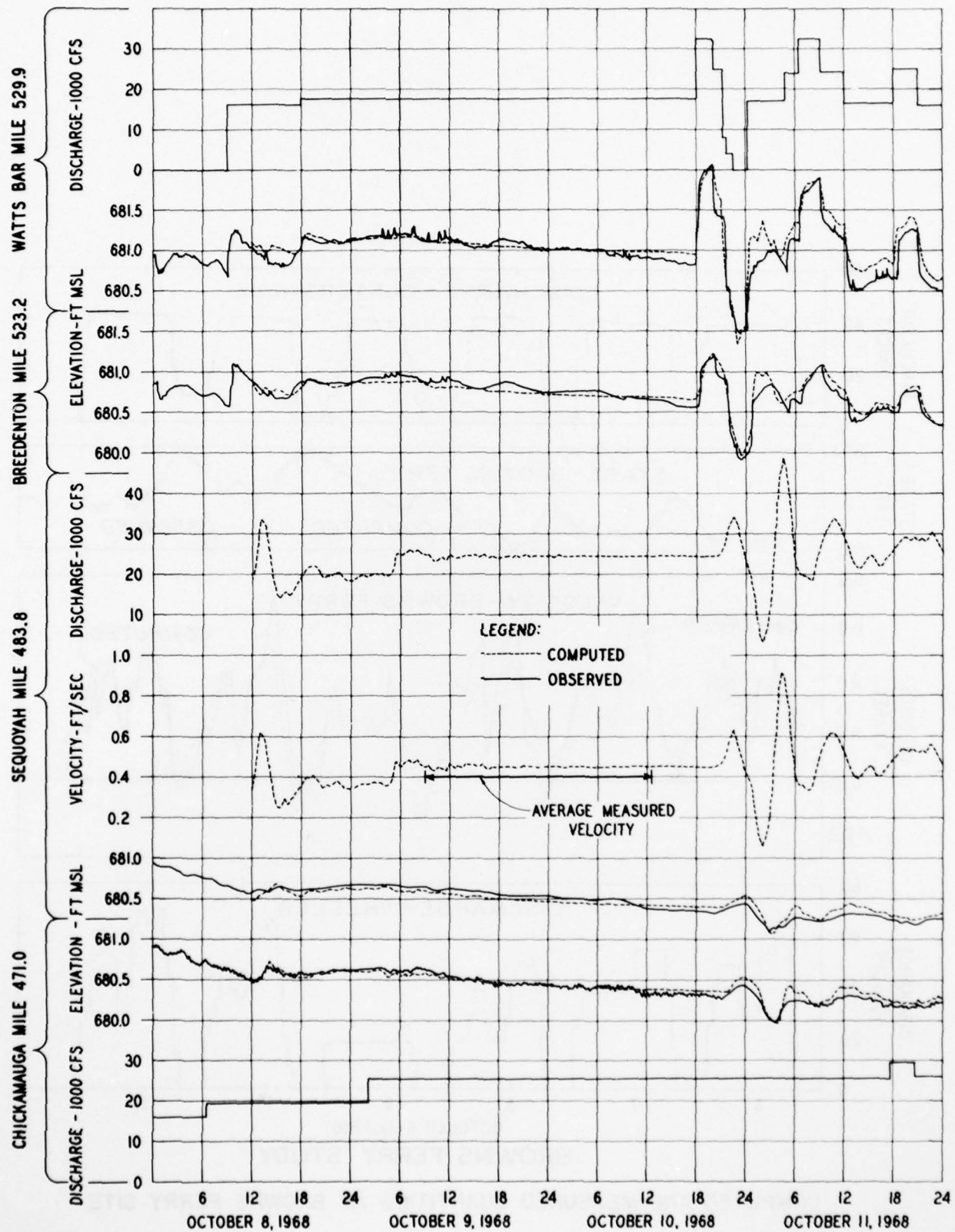

COMPARISON OF COMPUTED AND OBSERVED QUANTITIES
 SEQUOYAH NUCLEAR PLANT STUDIES

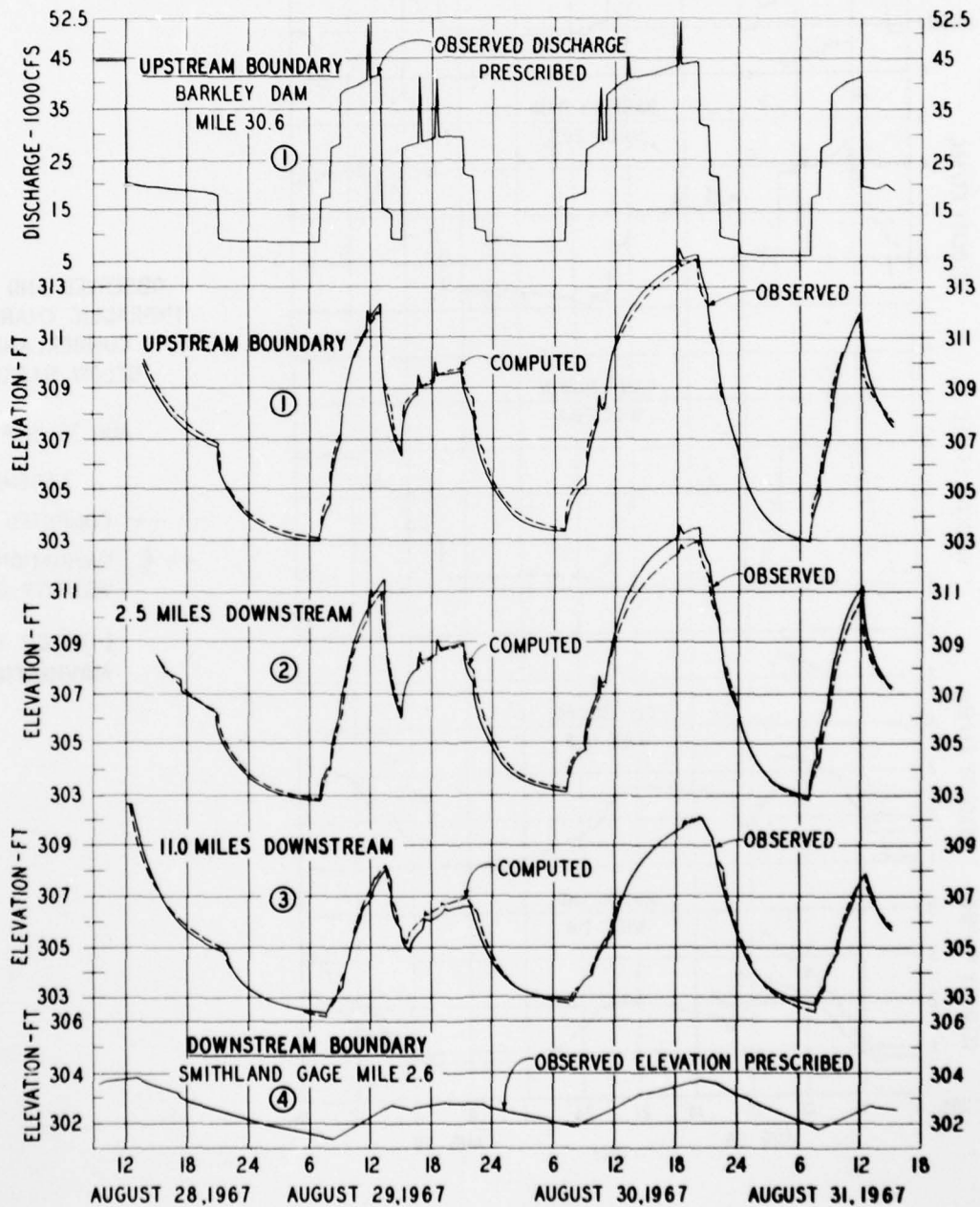
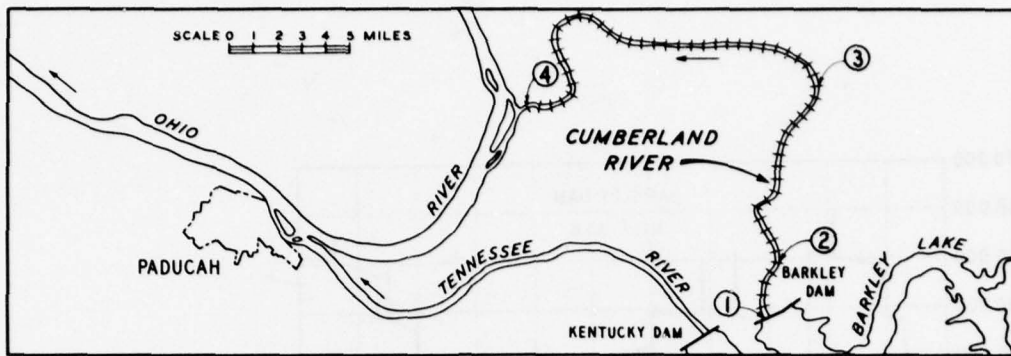

CUMBERLAND RIVER STUDY

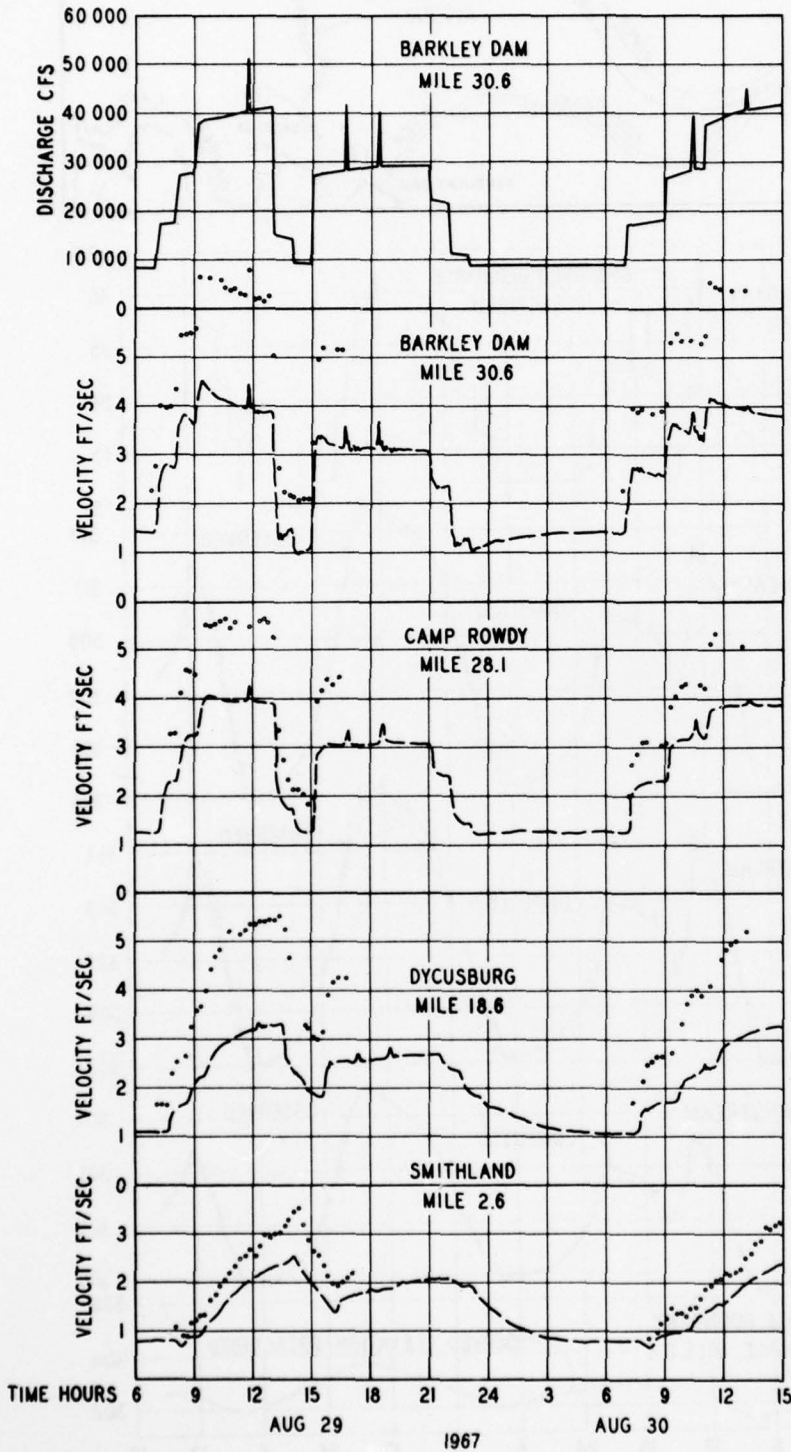

OBSERVED AND COMPUTED
HYDRAULIC CHARACTERISTICS
CUMBERLAND RIVER
BELOW BARKLEY DAM

AUG 28 - SEPT 1, 1967

LEGEND

- COMPUTED MEAN VELOCITY
- NAVIGATION CHANNEL VELOCITY OBSERVATION

(UPPER 11' OF
NAVIGATION CHANNEL)

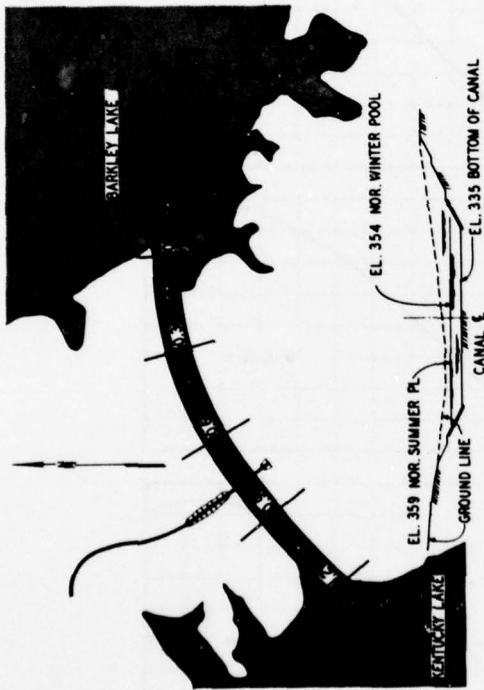

TYPICAL CROSS-SECTION

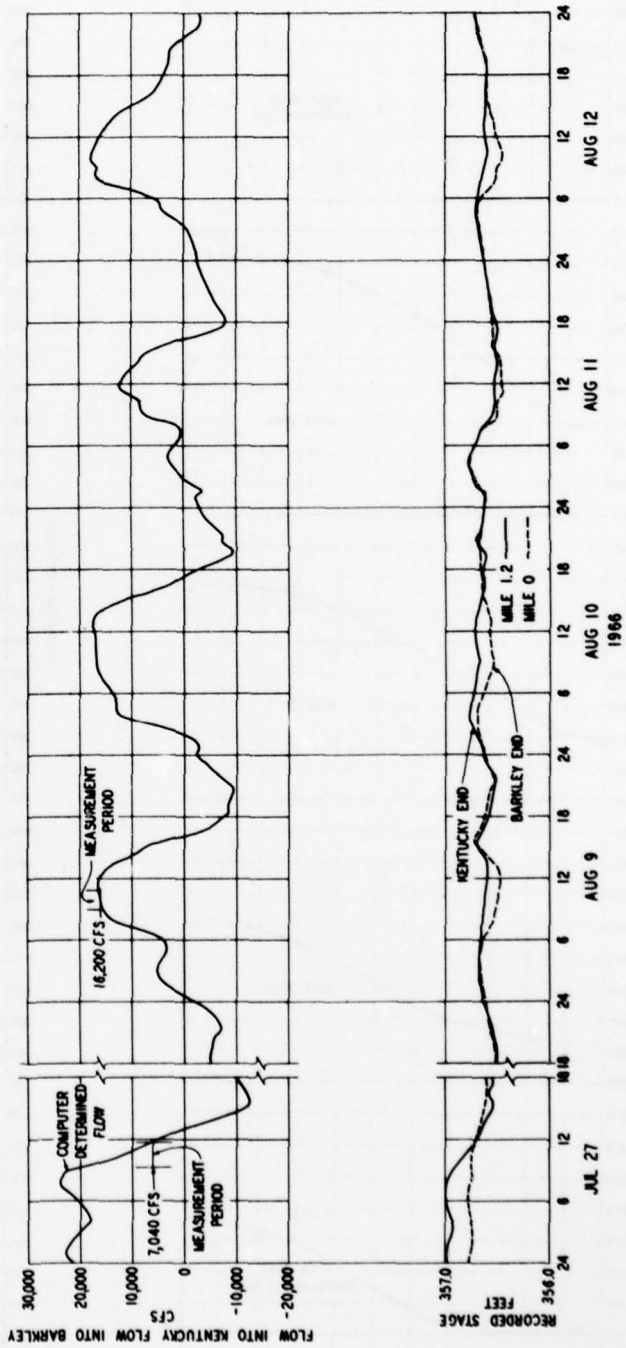

TYPICAL RESULTS FOR KENTUCKY-BARKLEY STUDY

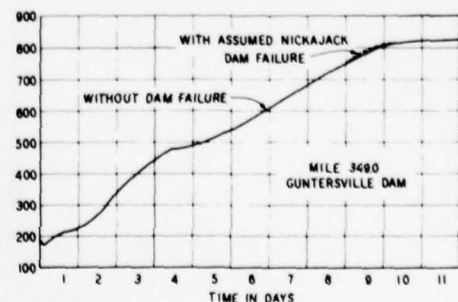
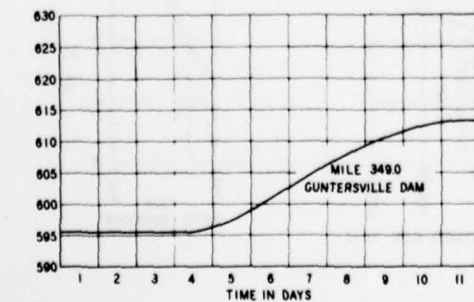
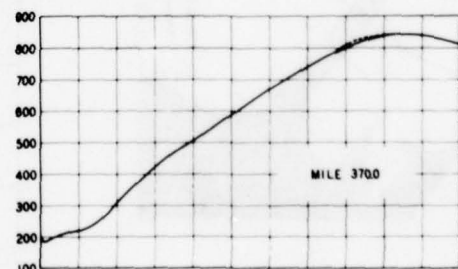
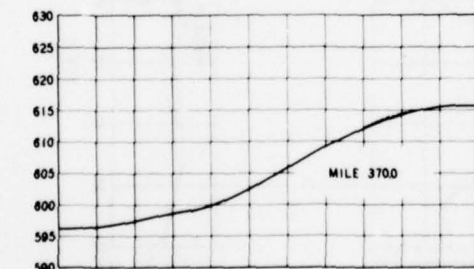
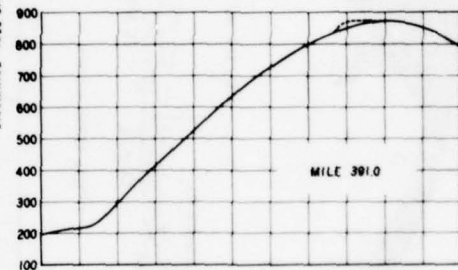
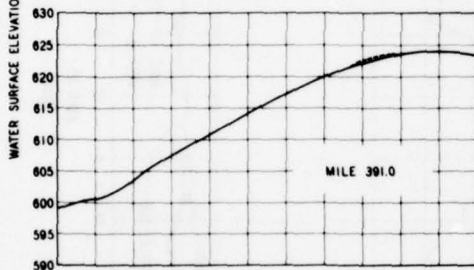
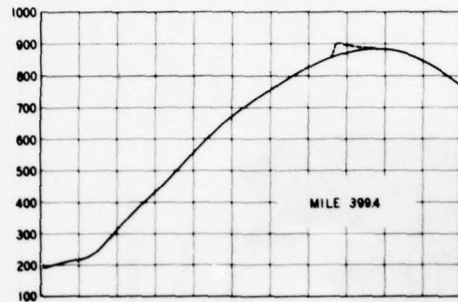
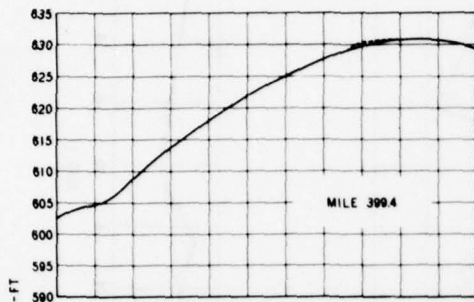
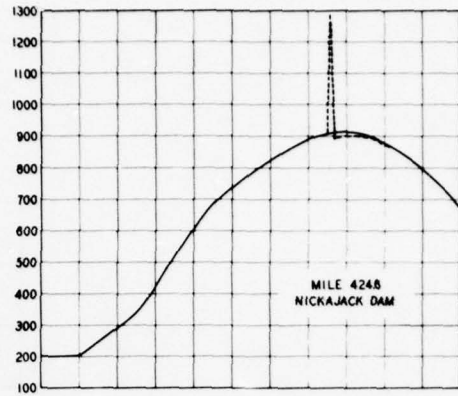
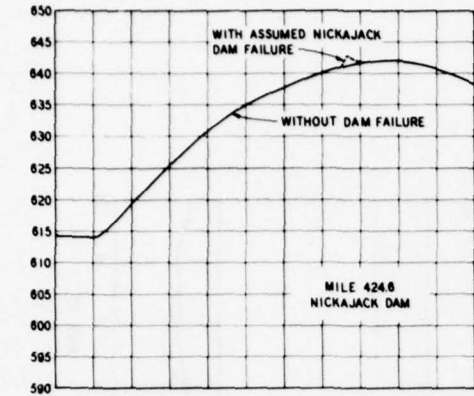

GUNTERSVILLE RESERVOIR
MAXIMUM POSSIBLE FLOOD

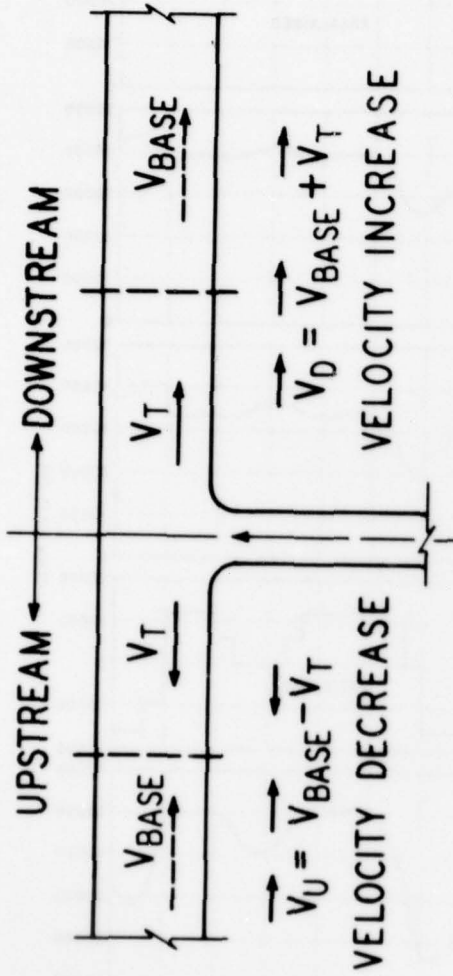

TURBINE OPERATION

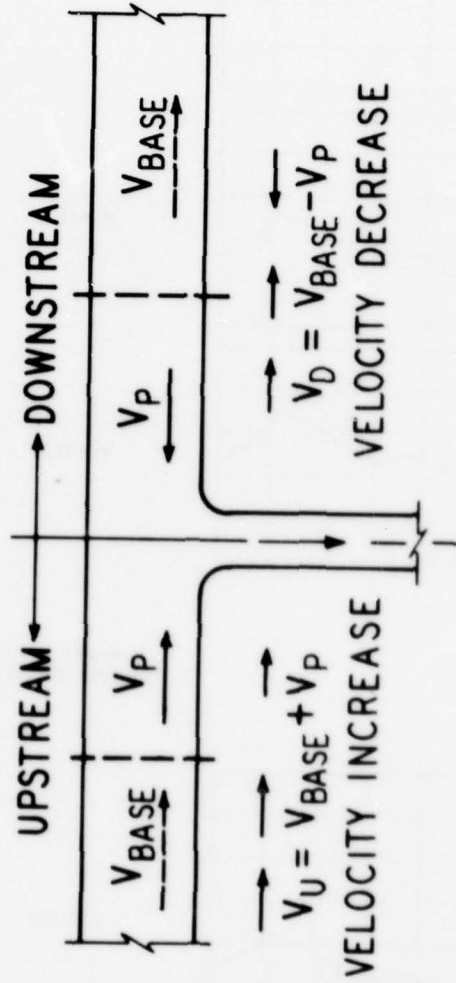

PUMP OPERATION

EFFECT OF PUMPED-STORAGE PLANT ON RESERVOIR FLOW



MI 471
CHICKAMAUGA

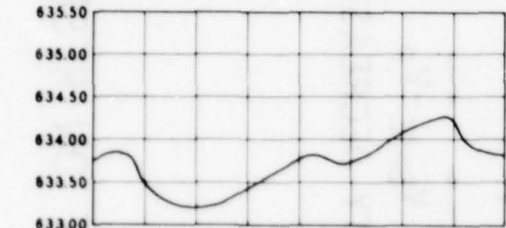

MI 449.85

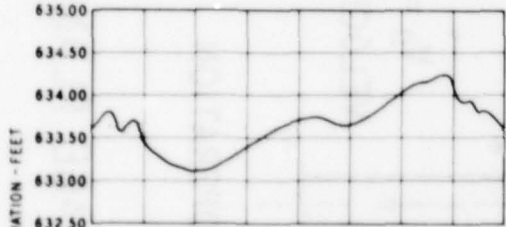

MI 445.75

MI 443.64-444.75
RACCOON MOUNTAIN

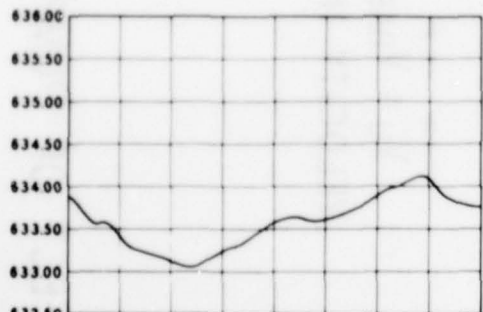

MI 441.54

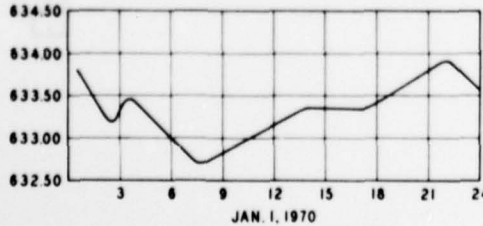

MI 424.7
NICKAJACK

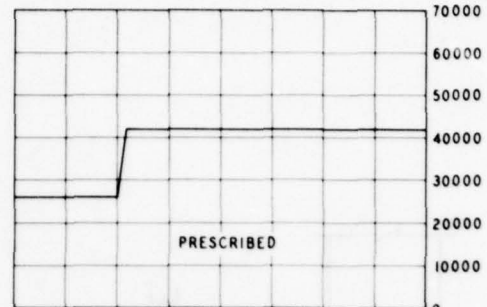

PRESCRIBED

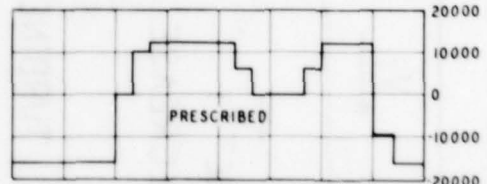
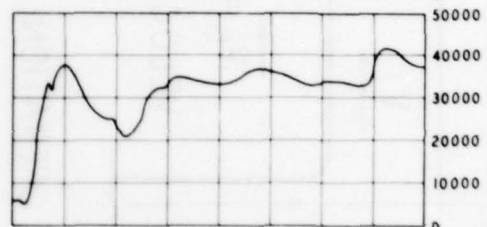
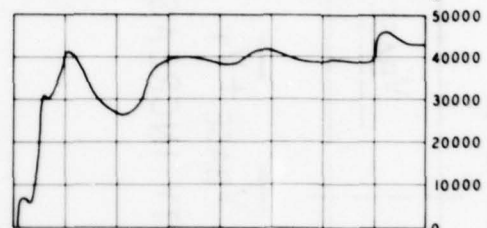

PRESCRIBED

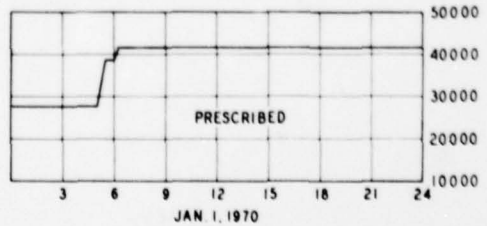
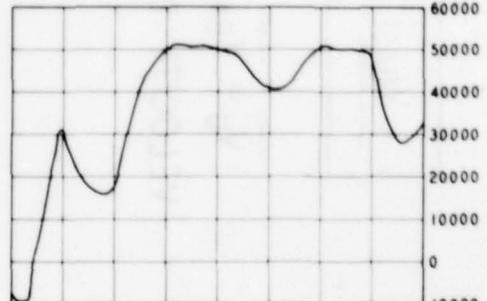

PRESCRIBED

WATER SURFACE ELEVATIONS

WATER FLOWS

TRANSIENT FLOW RESULTS - NICKAJACK RESERVOIR

PLATE 9

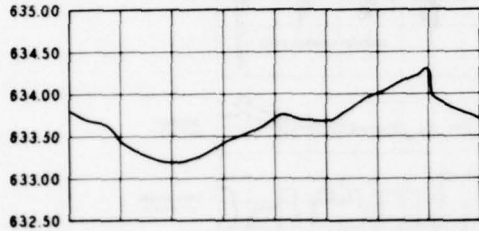
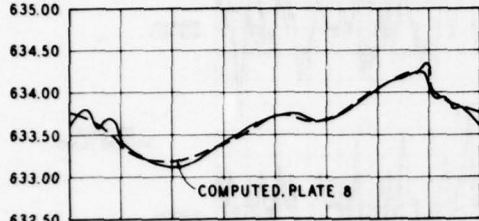
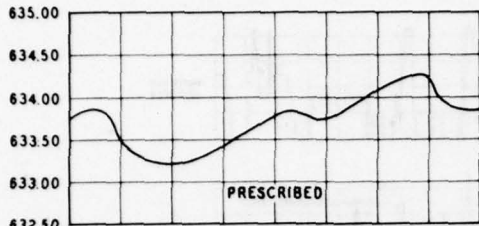

MI 444.53 - 441.81
RACCOON MOUNTAIN

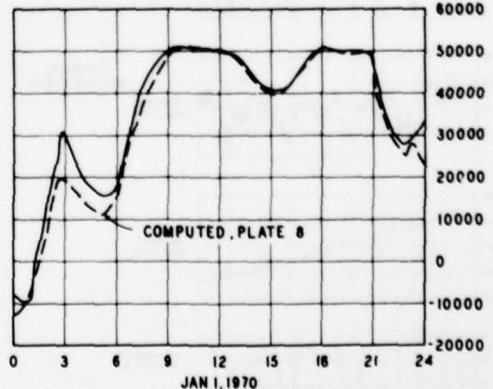
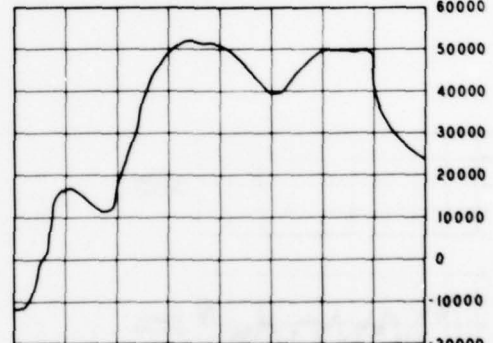
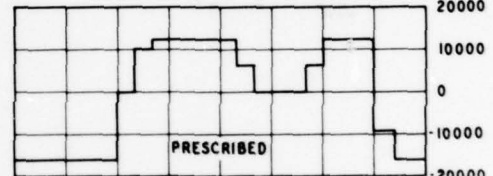
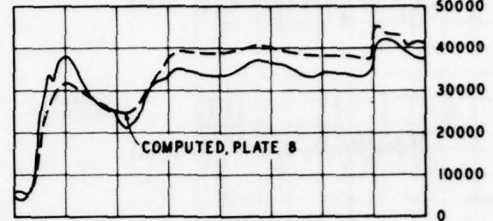
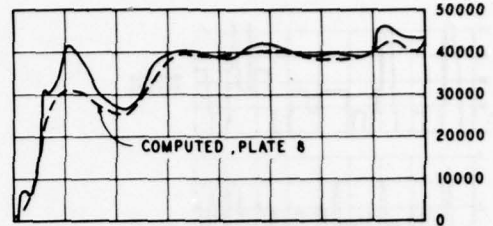

ELEVATION - FEET

FLOW - 1000 CFS

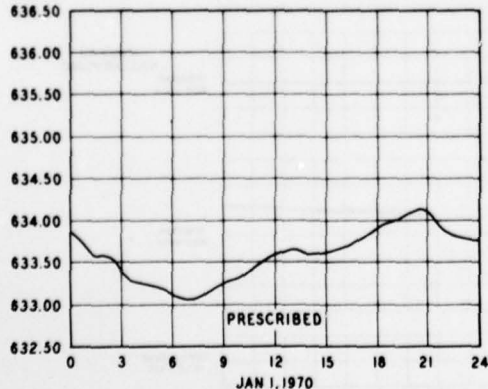
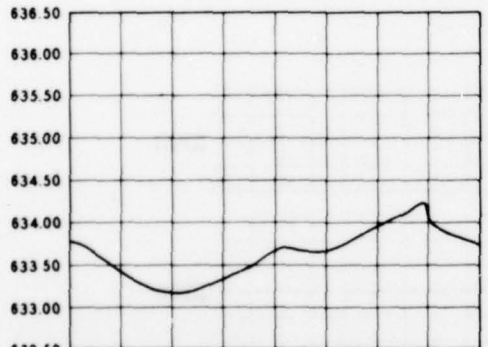

WATER SURFACE ELEVATIONS

WATER FLOWS

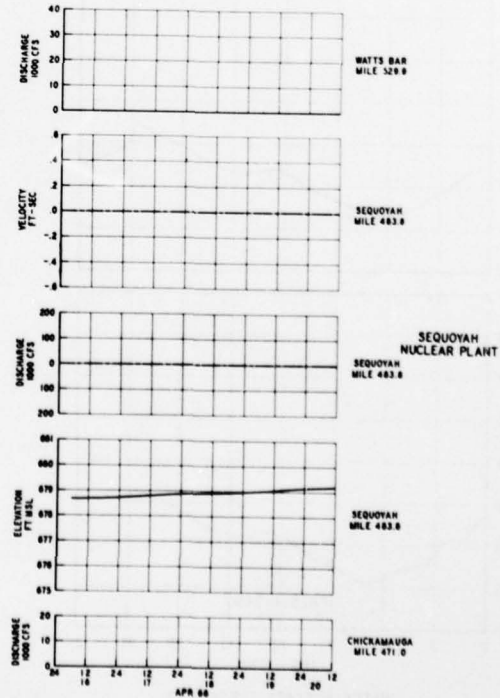
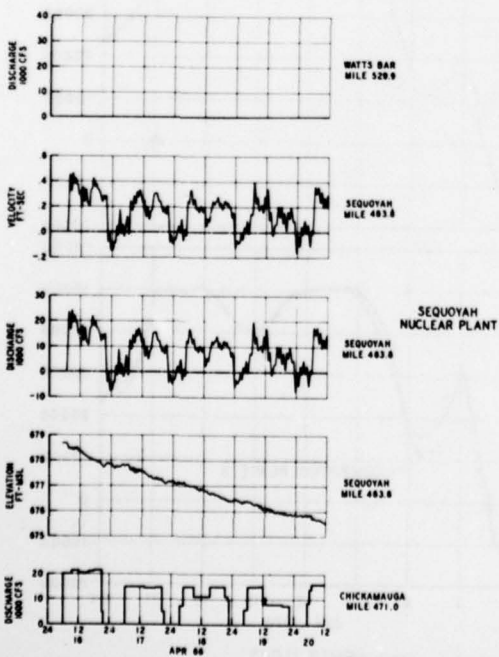
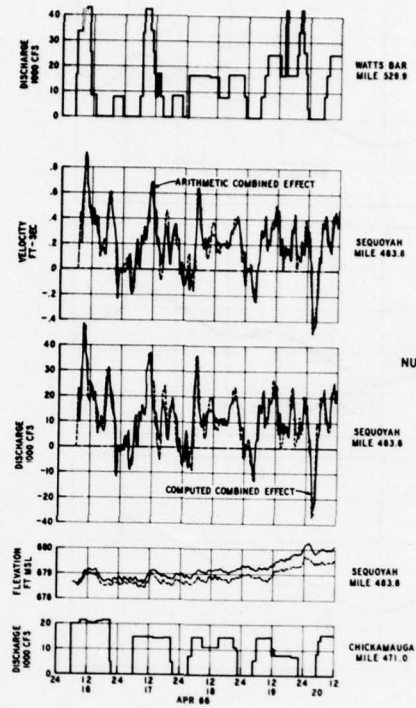
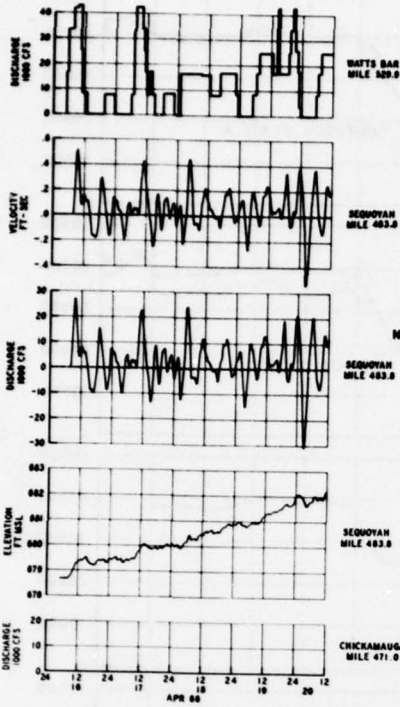

HYDRAULIC TRANSIENTS IN THE TVA SYSTEM
OF RIVERS AND RESERVOIRS

Discussion

Question, Mr. Matthews: Are projections of flows below Barkely Dam on the Cumberland available?

Reply, Mr. Price: Results of the computer studies were sent by TVA to the Nashville District. What has been done as a result of this study is unknown to me. There may have been further analysis of the data and problem by the Nashville District but I do not know this.

MANAGEMENT OF COMPUTER USE IN SOLVING ENGINEERING PROBLEMS

By

Augustine J. Fredrich¹

INTRODUCTION

Telling an engineer who uses the computer that "he will like using the computer when he learns how" may seem ridiculous, but so does telling a baseball player who just hit a home run that he will like playing baseball when he learns to hit. And yet there are many baseball fans who will agree that there is more to being a great baseball player than just hitting home runs. Similarly, effective computer use for engineering requires much more than simply writing programs, preparing data and reviewing output.

When computers were in their infancy and engineering applications consisted primarily of computerization of standard manual techniques, there was not too much need for engineers to be concerned with managing computer studies. Since the engineer was relatively familiar with the computational techniques employed in computer solutions and since, by present standards, the computers were not too fast or too efficient, there was little concern that computer use might get out-of-hand. Throughput time for studies accomplished by computers was not enough faster than the time required for manual studies for a competent engineer to be concerned about his ability to control the overall study. However, just as the parent must become more vigilant as an infant progresses from crawling to walking, engineers have had to learn to exercise more control over technical studies as computer capability increases and computational techniques become more complex.

The use of computers in engineering has now advanced to the point that managing the use of the computer in solving an engineering problem may be more important than the development of the solution technique. The availability of larger and faster computers and the expansion of technical knowledge have challenged engineers to develop solutions to problems that heretofore were unsolvable. Even in technical areas where traditional solution techniques were thought to be adequate, computerization of these solutions has, in many cases, added new dimensions to the problems and their solutions.

Although the cost per unit of work accomplished usually decreases as the speed and size of the computer is increased, the capability for more **extensive** and improved analyses that are a natural result of the larger and faster computers can result in a higher overall computer cost if the overall study is not carefully managed. Furthermore, newly developed

¹Chief, Research Branch, The Hydrologic Engineering Center, 609 Second Street, Davis, California 95616

analytical capabilities in many technical areas are causing increased competition for computer access during "prime-shift" time and increasing competition for available funds for technical studies. Unless the computer is used effectively in hydrologic engineering (or any other field) the relative value of the computer will diminish as far as that technical subject is concerned. In fact, since the expenditure of funds on computers is not tightly constrained by either time or manpower, as was the case in precomputer days, the computer can become a liability--ravenously consuming the available study funds without producing the needed results.

Having considered the potential adverse effects of poorly managed computer use it is obvious that it is worthwhile to develop principles of engineering management that can be applied by engineers and engineer-managers to insure that the computer is used in such a way that it is an asset to any given study. These principles must be developed and applied in such a manner that they provide effective and efficient control over computer analyses without unduly restricting creative applications.

MANAGING COMPUTER PROGRAM DEVELOPMENT

An engineer, given a problem to solve and given the availability of a computer, must make one of three decisions: use manually-oriented solution techniques; use the computer with an available program, modified if necessary; or use the computer with a program developed for the problem at hand. Frequently, neither of the latter decisions could be justified for any particular problem, on the basis of either economy, manpower utilization, time savings, or improvement of results. Unless the problem is exceptionally large and/or complex or unless a well-documented program is readily available for use with little or no modification, there are ordinarily manual computation techniques that will provide acceptable, if not fully adequate, solutions. Furthermore, the manual solution can often be obtained at a lower cost and in a shorter time than the initial computer solution can be obtained.

At first glance it would appear, then, that there are only a few opportunities for an engineer to develop and use computer solutions in his routine work. However, this appearance is deceptive because the engineering environment does not normally consist of single tasks done once and never repeated, so the use of the computer should not be viewed in the context of solving a single problem once. Instead, computers are used in engineering to repeatedly obtain solutions to problems in which the basic principles and computations are invariant but subject to wide variations in assumptions, criteria, engineering judgement and data availability. Consequently, the decision to develop a computer program or make major modifications to an available program represents an investment

AD-A052 603

HYDROLOGIC ENGINEERING CENTER DAVIS CALIF

F/G 8/8

PROCEEDINGS OF A SEMINAR ON COMPUTER APPLICATIONS IN HYDROLOGY --ETC(U)

FEB 71 L R BEARD, D R BURNETT, R E BENNION

UNCLASSIFIED

HEC-SP-04

NL

2 of 3
AD
A052603



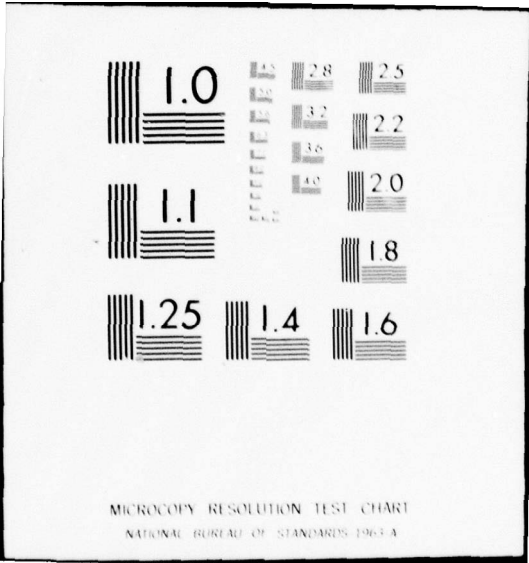

of current time, manpower and funds into an implement which will yield savings in all of the inputs at some future time, with the realization that the investment probably costs more than its value for any single application. As previously noted, there are exceptions such as the development of programs for one-time use on extremely large or extremely complex problems, or on problems involving analyses or processing of very large quantities of data that are readily available in a usable form.

If the foregoing statements are valid - and experience indicates that they are in many technical areas - the value of a program for engineering uses can be measured by its utility as reflected by repeated applications in the specific problem area. In many cases the applications of a given program will not always be exactly the same for various problems. From application to application the problem may vary with respect to data availability, number and type of assumptions, output requirements, and even study objectives. And yet, if properly developed, a single program can be used through an extensive range of problem variations without major modification. As one might expect, this flexibility is not an intrinsic characteristic of all programs. It must be deliberately built into a program, and it is done so at considerable cost in time, money, and engineering talent. However, if properly done, this investment will be recouped many times over through repeated applications of the program at little or no additional cost.

The development of flexible or generalized (as they will be called herein) programs can be subdivided into six basic tasks--all of which must be accomplished within two overall guiding principles. The six basic tasks are: (1) evaluate the output needs (What information must the program produce for the engineer to complete the problem solution?); (2) consider the available data (What data can be expected to be available for use in solving the problem?); (3) evaluate alternative computation techniques (What computation technique is best for producing the needed information given the available data?); (4) conceptualize the program framework (How will the program logic be organized to perform the required computations in an efficient manner, in the desired sequence, and in such a way as to facilitate possible future modifications?); (5) develop detailed computational and data manipulation algorithms (What programming must be used to transform the engineering logic into a program?); and (6) test and verify program logic (Does the program perform the required computations properly?). The two guiding principles that must encompass the entire program development are: the program and the programming effort must be directed toward solution of the basic engineering problem, and the program capabilities must be thoroughly documented if the program is to be of maximum value. Figure 1 depicts the relationship between problem orientation, program documentation and the steps involved in program development. Effective management of the development of a generalized program or, to a lesser extent, a special purpose program requires familiarity with each of the steps and their supporting rationale.

As indicated in figure 1, the necessity for continually considering the nature of the engineering problem must underlie the entire effort. It is all too easy to become lost in the details of the programming effort with a resultant loss of awareness of the engineering objectives. Losing sight of the engineering problems at any point in the program development can result in the program becoming an end unto itself rather than a means of accomplishing an engineering task.

Development of a generalized program should not be relegated to just whomever happens to be available. The task is usually a major undertaking that should be assigned to a highly competent engineer-programmer who is thoroughly familiar with the basic problem and capable of anticipating the possible variations in the problem so that provisions for treating the variations can be incorporated into the program. Failure to identify and provide for common variations in the problem at this stage can significantly increase the effort required for future modifications--even to the extent that modification is not justified for some relatively common applications.

The second consideration that should underlie the entire program development effort is the need for documenting the program capability. Too frequently, engineers attempt to make program documentation a seventh step that is initiated after the program has been tested and verified. Since the elapsed time between inception of the program and its completion can be relatively long, important facts can be omitted from the documentation if it is not carried along concurrently with the program development. Furthermore, since all users other than the original authors must rely on the documentation to explain the program's capabilities, it is imperative that the documentation be complete if the benefits of repeated applications over a relatively long period of time are to be attained.

The documentation must contain information for both the engineer-user (who may or may not be a programmer) and the engineer-programmer. The information for the engineer-user should consist of an explanation of the engineering problem that can be solved by using the program, a description of the computation techniques used in the program (with references to appropriate textbooks or manuals, if necessary), illustrative examples which demonstrate the program's capability and which include a sample input and output, and detailed instructions on preparation of input for the program. The engineer-programmer's interest in the documentation will be somewhat different from the engineer-user's interest because the engineer-programmer will ordinarily be concerned with modifying the program. Consequently, for his purposes the documentation should contain relatively detailed information on the program logic, program structure, and hardware and software requirements.

Unfortunately, there are not many well-documented engineering programs available, even after more than fifteen years of fairly widespread computer

use. This can be attributed in a large part to the fact that most engineering organizations are production oriented, and program documentation detracts from immediate production. However, immeasurable duplication of effort and lost value in available but unusable programs have resulted from this lack of documentation, and engineer-managers can no longer afford to ignore the need for thorough documentation.

With the understanding that program development should take place in an environment that emphasizes problem orientation and thorough documentation, some elaboration on each of the six steps in program development is warranted. It is obvious that the output requirements for the program are a fundamental consideration. In prescribing the output requirements the engineer must consider the information normally available from manually-oriented solution techniques as well as additional useful information which might be derived from the computerized solution. The engineer-programmer should be encouraged to study the problem from many viewpoints-- attempting to identify as many important elements of the problem and the solution as possible. All too frequently we tend to limit our consideration of the solution to what we have been accustomed to obtaining from traditional solution techniques that may have been constrained by the necessity for hand calculations.

As an integral part of the consideration of output requirements the engineer-programmer should also consider variations of the basic problem that are both more general and more specific than the problem at hand. Since the output requirements often vary considerably with changes in study objectives, the consideration of various scopes of the basic problem gives additional insight into the nature of the output needed, the types of data that might be available as input and the types of computation methods that might be satisfactory. In considering the wide range of potential output requirements it is important to recognize that the computer can easily generate more output data and information than an engineer can effectively use, unless the programmer carefully selects only those output items that are actually important to the problem solution. Whenever possible the user should be permitted to exercise selective control (by input) over the output so that he can obtain only the output that is useful and pertinent to his particular problem.

A final consideration with respect to output requirements is that the computer output will occupy the same place in engineering files as the manual computations did in the past. Consequently, the output itself should be designed so that future referrals to the document are as independent of knowledge of the program as possible. To accomplish this the engineer-programmer must organize the output information so that it is self-explanatory to an engineer familiar with the technical subject. The output format should contain common technical terminology and abbreviations rather than programmer-generated variable names, and the format limitations imposed by filing and reproduction should also be considered, if possible.

Analyses and summaries of the output data, usually considered to be a separate operation in manual computations, can often be incorporated into the program and will then become an integral part of the program output.

The second step in program development, consideration of available input, is also essential in the development of generalized programs. Since data availability varies considerably from problem to problem--even without the variations caused by changes in the scope of a study--it is necessary to make provisions for extremely flexible data input to insure that the program will be usable. Ideally, the program should be designed so that it can be used equally well with a minimum amount of data if the study is broad in nature and detailed data are not available, or with a complete set of data for more detailed studies.

Once the input and output requirements have been established, alternative computation techniques can be evaluated with respect to both their adaptability for computerization and their utility with the required input and output. Frequently this step is overlooked because the engineer-programmer decides to computerize an existing manual solution without evaluating whether the manual solution is really the best possible technique or whether it is simply the best that could be done manually. The speed and accuracy of the computer and the increases in scientific and mathematical knowledge during recent years have created new computation methods for many problems and have made feasible other methods that were known to exist in the precomputer era, but were not amenable to manual application. Also, new techniques and new knowledge have expanded our understanding of many problems and it is often desirable to obtain output data that cannot be readily obtained from manual methods, even if they are computerized.

Before attempting extensive coding of the program logic it is desirable to conceptualize the program framework. This can be done mentally if the program is relatively small, but it is usually necessary to develop some type of flow chart such as the functional flow chart shown as figure 2. This type of chart is useful in later stages of programming because it shows the relationships of various modules in the program to one another. The flow chart should be detailed enough to insure that the interrelationships between the various modules and the data manipulations are identified so that they can be provided for in the coding. In cases of complex computation routines it may be desirable to develop more detailed flow charts (such as the one shown in figure 3) during the course of the program development. If the functional flow chart and any other charts explaining the program logic are developed using standard technical terminology rather than program variable names, they can be used very effectively in the program documentation.

The fifth and sixth steps--development of the computational and data manipulating algorithms and testing and verification of program logic--are

the two facets of programming which have received the most emphasis in the past. Although most engineer-programmers are relatively proficient in coding, testing and verifying programs for technical applications, experience indicates that improvements in the overall development of a program can be realized in this phase by following the four preceding steps. The improvements will result from better planning and design of the program-- minimizing false starts and inconsistencies in the coding of the program. Also, the thorough consideration of the problem in the early stages of program development should help in the development of comprehensive tests. Better, more comprehensive tests should, in turn, reduce testing time and effort, and minimize the possibility of errors in the finished program.

MANAGING COMPUTER USE

If the preceding section of this paper can be considered to have dealt with the "planning, design, and construction" phases of computer utilization in engineering, the remainder of the paper will deal with the "operations" phase. Having a good, **well-developed program for use in a particular application** isn't the sole factor in making effective use of the computer. The best of programs is worse than worthless in the hands of an uninformed, misinformed, or misguided user. Just as great technological breakthroughs have been misused to the detriment of mankind in some instances, good programs can be misused to produce "more errors faster and at a lower cost per error than a whole stadium full of mathematicians working by hand!" To assist the engineer-manager in guidance of the computer analyses associated with a technical study, five principles of managing computer use are proposed: (1) collect, analyze, and check the basic data; (2) document assumptions and study criteria; (3) control sequence of computer runs, (4) analyze and summarize results; and (5) develop conclusions, recommendations and reports. In the following paragraphs each of these principles is discussed in some detail and suggestions for implementing the principles are proposed.

Since the computer is not always able to distinguish good data from bad data, and since most programs do not contain provisions for including a full listing of input data in the program output, it is important for the engineer to develop and preserve a record of all important input data, its source, and its relative accuracy. This record should be filed with the study results to insure that a complete history of the work is available for future reference. In addition to collecting and analyzing the basic data, **the engineer must check the data for errors and inconsistencies** which might cause the job to be terminated before it is completed or, worse yet, render the completed job useless. In the days of manual analyses it was not as important to check each data item at the time of data collection and processing, because it was assumed that the engineer performing the

study would exercise some judgement concerning the validity of each data item as it was used. In computer programs, however, this type of check can be made only in very general terms that in no way approximate all of the judgement that an engineer would bring to bear on determining the validity of the data. Since the production of erroneous results not only invalidates the particular run but also frequently creates an unfavorable situation with respect to the use of the computer for any application, the importance of complete checking of the input data cannot be overemphasized.

The assumptions and criteria associated with a particular computer analysis of a problem often are as significant as the analysis itself--as far as the results are concerned. And yet, virtually no programs have provisions for qualifying the output to reflect the assumptions or criteria for the study. Since the inclusion of this type of provision in a program is rather difficult--given the wide range of possible assumptions that can be associated with engineering studies--the engineer-user must record this information and see that it is attached to the results in such a way as to insure that the results are not misinterpreted or misused. This problem is not limited to computer analyses, as engineers have been concerned about misuse of their studies since long before the computer came into use. However, it is compounded in computer studies because the lack of supportive information for an analysis is usually more pronounced in computer runs, and because many people are still placing more faith in what the computer prints out than they would place in a similar document produced by a man.

The problems of collecting, analyzing and checking input data and of documenting assumptions and criteria are growing rapidly with increased computer use by engineers. Because the computer gives us the capability to analyze a basic plan and many variations of that plan at a relatively small cost in time and money, we tend to perform the additional analyses without describing and documenting the rationale that led from one analysis to the next and without documenting the changes in data, assumptions and criteria. While this seldom creates problems during the study itself, the results are disastrous when the results of the analyses must be described in reports or when reference must be made to the studies in the relatively distant future. Just as documenting the program itself is a present cost which will pay dividends in the future, documentation of the precomputer phases of a particular study are an essential price which must be paid if the computer is to be used effectively.

Controlling the sequence of computer runs is one of the most difficult tasks facing the engineer-user or engineer-manager. The apparent low cost of additional computer analysis and the normal technical curiosity of most engineers frequently entice engineers to make analyses that fall into the "nice-to-know" category as opposed to the "need-to-know" category. Such investigations are certainly desirable and should be encouraged when the work schedule and study funds permit. However, it must be realized that the costs in time, money and manpower of these supplemental investigations

are usually far greater than the cost of the additional computer time needed to make the computations. Too many engineers have fallen into the trap of pursuing one "nice-to-know" study after another until the point is reached where the study that must be done is still incomplete and the funds and time are gone. The mystique of "just one more run" to an engineer can become much like the "I'll quit tomorrow" syndrome of the cigarette smoker or narcotics addict. However, for the engineer "tomorrow" comes much sooner than for the smoker and the addict, and--while the physical repercussions may not be as great for the engineer--his job security and credibility can certainly be adversely affected.

The most common cause of uncontrolled computer use is the absence of a realization that the input must be documented and the output must be reviewed and analyzed, and that the cost of these operations far exceeds the cost of the computer run itself with respect to funds, time and manpower. Experience indicates that the best approach to use of the computer in a major study is to lay out, in advance, a study plan which clearly indicates where the computer is to be used and what results are expected. If explorative type efforts are contemplated, definite time and/or monetary constraints should be indicated to provide a gage against which actual performance can be measured. The engineer-manager can use this study plan to evaluate the study progress and can assess the impact of unplanned computer use on the overall study effort. As long as the study plan is used as a guide or standard rather than as an absolute constraint the plan will be a useful management tool rather than a restrictive detriment to effective and innovative computer use.

Even in a well-planned study effort there will be occasions where the results of a planned analysis will indicate that an unforeseen analysis should be or must be made. The aforementioned study plan should not be used as an excuse to avoid these analyses. Rather, the plan should be used to determine the potential effect of the unforeseen analysis on the study completion date so that additional planning or budgeting or both can be accomplished without being under the stigma of an already-missed deadline. Moreover, the engineer can use the plan to integrate planned and unforeseen analyses in a way which minimizes the number of computer runs that must be made. Since a certain minimal amount of input documentation and output analyses is associated with each run, the combination of two or more investigations into a single analysis, where possible, saves not only the computer cost but also the associated time and manpower costs.

The need for thorough output analysis has already been alluded to in the preceding discussion on controlling computer study sequences, and experience has indicated that ineffective analysis of computer results is a major component of mismanaged studies. The computer is capable of generating, in any given study, far more output than any engineer or group of engineers can analyze in any reasonable length of time. This is one

of the important reasons why the number and sequence of studies must be carefully controlled. An "information explosion" of the type caused by indiscriminate use of the computer can overwhelm the capability of the most competent and well-intentioned engineer to detect even the most obvious inconsistencies or the most important results. If the study is properly planned the number of computer runs will be carefully controlled, and there will be some predetermined output analyses for each run. In addition to reviewing the output with respect to the preconceived objectives, the engineer should carefully review the output to determine that the overall results are logical with respect to what was anticipated. Since occasionally input errors are overlooked--even in the most thorough checking process--it is worthwhile to examine the output for possible discrepancies that might be indicative of input errors. It is far better to detect errors at this point than at some time in the future after additional studies have been based on the output results.

As an important part of the output analyses the engineer should record any important conclusions based on the results and any supporting calculations or interpretations of the output data. This type of record, when filed with the computer results and when properly related to the results, forms the basis of a retrieval system which is helpful in reconstructing the study logic in the future. Since modifications of completed studies are not infrequent in engineering work because of alterations in the overall study objectives, the capability to reconstruct a study sequence is important.

Transforming the results of computer analyses into a finished engineering report is the final step in the "operations" phase, and it is a step which is frequently stumbled over. Developing conclusions and recommendations is the engineer's forte. Substantiating them is his downfall! Instead of developing clear and concise rationale for our conclusions and recommendations to decision makers we tend to try to overwhelm them with the sheer volume and details of our work. However, we are finding that--interesting as they are to us--the details of our labors and the stacks of output data we can and do develop are of little or no interest to the decision makers or to the general public. To gain acceptance of our work and approval of our recommendations we must work dilligently at improving our ability to communicate our findings and our feelings to persons who are not as close to the problem as we are. This problem, like many of the problems described in this paper, did not originate with the advent of the computer but the magnitude has certainly increased with the increase in computer use.

By giving us the ability to explore more facets of a problem the computer may help us develop explanations of complex technical subjects, but not until we learn to employ it effectively. Computer-generated tables and charts are desirable when they clarify or supplement an oral or written explanation. They are worse than useless when they merely present endless columns and rows of unanalyzed data. To use the computer effectively in

this phase of a study the engineer can relegate to the computer the task of extracting from all of the data, that which is really important, or the task of arranging the data so that he himself can more readily extract the important information. In this role the computer becomes a true asset to the study instead of a number-spewing liability.

SUMMARY

We have passed through the era where the computer was a toy to be tinkered with by engineers with a bent toward the new and innovative, and we are now entering into an era where the use of computers in engineering studies is of fundamental importance in doing a satisfactory job. The necessity for developing good management practices to correct our past inadequacies and to forestall the development of new and potentially more serious inadequacies in the future is obvious. Some possible principles of computer management have been outlined and discussed in this paper. What remains to be done is to discuss them, modify them as necessary, and finally--and most importantly--implement them.

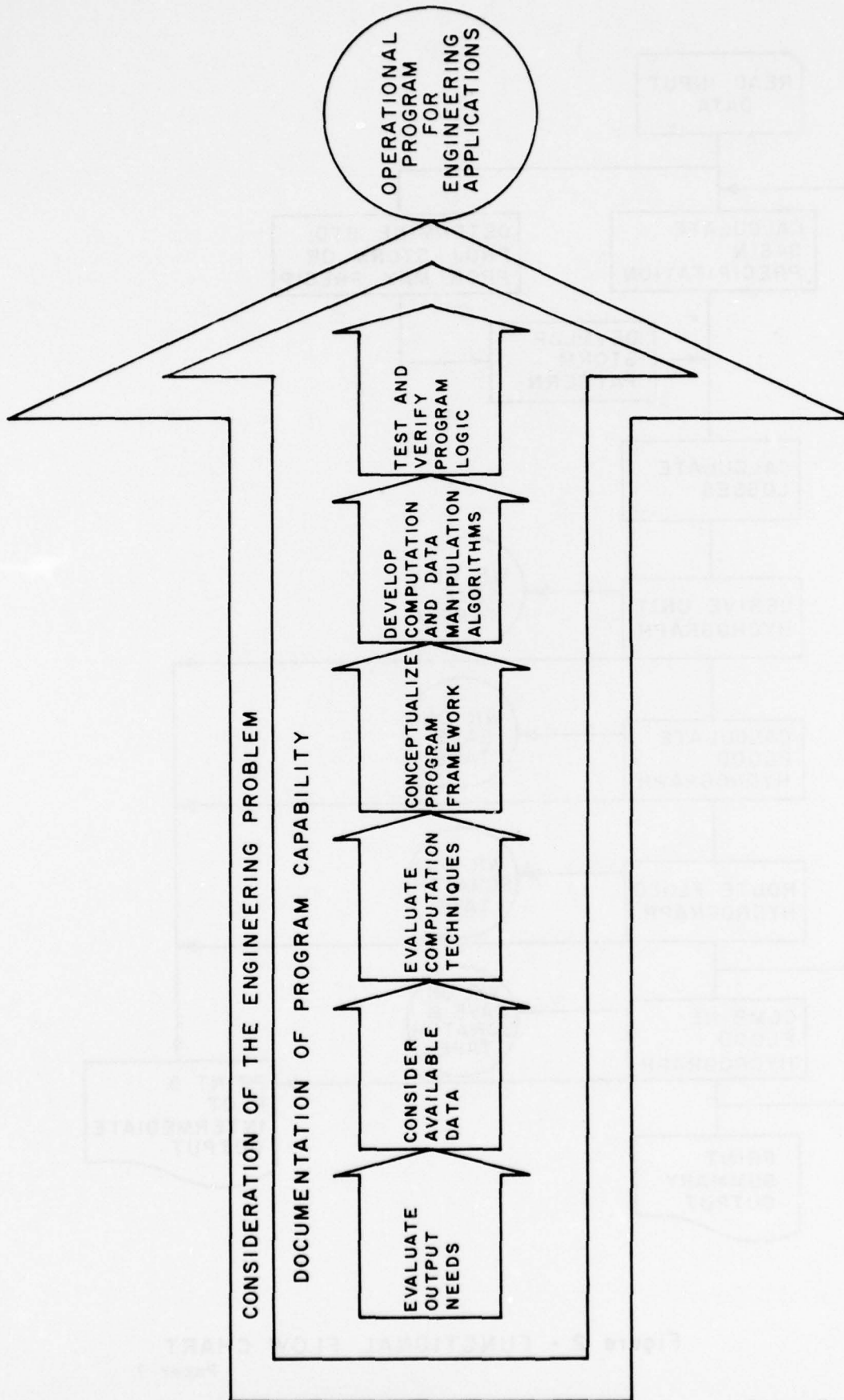
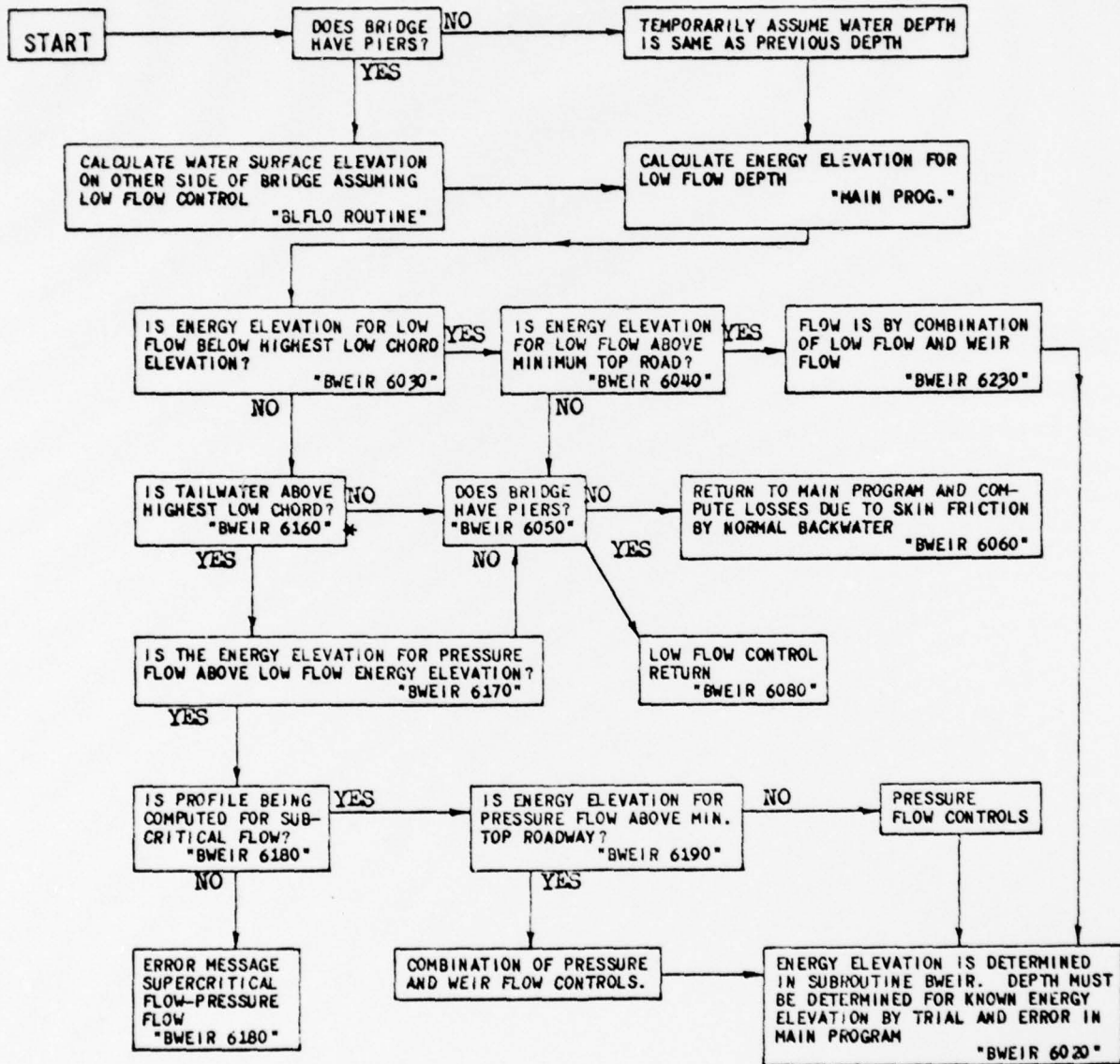

Figure 1 - COMPUTER PROGRAM DEVELOPMENT

FLOW CHART
SPECIAL BRIDGE ROUTINE



*Refers to statement 6030 of subroutine BWEIR

(After Eichert and Peters, "Computer Determination of Flow Through Bridges," 1970.)

Figure 3 - DETAILED FLOW CHART

MANAGEMENT OF COMPUTER USE IN
SOLVING ENGINEERING PROBLEMS

Discussion

Question, Mr. Matthews: How do you manage people working on programming so as to be most effective in overall results?

Reply, Mr. Fredrich: It is necessary to have firm fiscal and production control and knowledge of the problem and results expected. This will not happen until the executives and supervisors become knowledgeable about the capabilities of computers and how they and their users are managed.

Question, Mr. Beard: How much detail should there be in the program documentation?

Reply, Mr. Fredrich: The detail in the program documentation should be commensurate with the scope of the program. A program which performs a simple computation in a relatively inflexible way will require very little documentation; while a large, complex program with many input options and several alternative computation schemes or computation sequences will require much more documentation. In short, the documentation should enable the user to understand and effectively use all of the program's capability.

Comment, Mr. Wm. Thomas: In my opinion the program document would have to be sufficiently detailed to impart the practical experience of the programmer to the user if the user is just casually familiar with the type of problem the computer program is attempting to solve.

Question, Mr. Sharp: Mr. Fredrich, you have expressed the need to thoroughly document "generalized" computer programs, especially those contained in the library at WES that will not be backed-up by adequate applications assistance. I agree with the views you expressed in general. However, do you feel there is much danger of a problem arising from "over-documentation" of programs... to the point of appreciably discouraging their use... especially the more complex programs having several input options?

Reply, Mr. Fredrich: No, I don't think there is too much chance of that, given the current ability (or inability) of engineers to document their work. It will, however, certainly be necessary to maintain some control over the time and manpower spent on documentation to

insure that the expenditures are consistent with the capabilities of the program being documented and that the efforts are not wastefully misdirected. In the specific case of generalized programs, I cannot visualize "over-documentation" - at least not from the users standpoint.

Question, Mr. Eichert: Since we are talking about computer program documentation, I would like to ask the participants of this seminar whether the documentation of the HEC programs is adequate or not.

Reply, Mr. Fredrich: In many cases the HEC documentation is considerably less than I personally would like to see, but I have heard many people from other offices and other agencies say that the HEC documentation is far superior to most other documentation.

**COMBINING NEW TECHNIQUES AND COMPUTER TECHNOLOGIES
FOR PROBLEM SOLUTIONS IN HYDROLOGY**

by

**Eugene A. Cristofano
Hydraulic Engineer
Engineering and Research Center
Bureau of Reclamation
Denver, Colorado**

February 1971

Paper 8

Combining New Techniques and Computer Technologies for Problem Solutions in Hydrology

In the past decade, with the onset of the high-speed electronic computer, many problems in hydrology have been solved with the application of the computer. Most of these applications have simply used the computer as a high-speed adding machine or desk calculator without incorporating those numerical and mathematical techniques most compatible to computer applications.

I would like to digress for a moment to trace the evolution in the application of the electronic computer as a tool used to solve problems in hydrology. Use of the computer began with those facilities of very limited capabilities and such tasks as machine language programming, scaling, design of function generators, and the manipulation of non-alpha output hardware left little desire for the more sophisticated techniques of problem solving. Today, however, with modern computer facilities along with the various pseudo languages as software, little, if any, limitations are imposed in using the computer as a tool.

Three problems in hydrology were most commonly found as computer applications. These were namely: reservoir operations studies, flood frequency studies, and tailwater or backwater studies. I think this was due to the repetitive nature of these type problems and the fact that a minimum of logic and decisionmaking concepts were employed. Also, one sometimes found statistical techniques, such as simple and multiple linear regression analysis and curve-fitting, among the tools of hydrology that were used as computer applications.

With these types of studies as our early background, we in the Bureau of Reclamation, and I am sure most of you, have found that today's problems in hydrology are really those of water resource systems analyses and they are multipurpose or multidiscipline in objective, and consequently, multidimensioned in mathematical solution.

Our efforts in hydrology in the Bureau of Reclamation for the past 2 years have been directed towards an extensive investigation of mathematical and statistical techniques that will enable a more efficient use of the computer and provide more flexibility in our hydrology studies. We are conducting our investigation in two phases. The first phase being the application of these techniques without materially changing concept or philosophy. The second phase will be to use these same techniques to provide an insight into the new concepts and philosophies of present day hydrology.

We have then, as a necessity in the continuous evolution, initiated experimentation with these new statistical and mathematical techniques

in solving problems under the old philosophy and obtaining insight into the new philosophy. Before going further, you might ask what I mean by old philosophy and new philosophy. I think I would define old philosophy that, where, as hydrologists, we provided two or three alternatives to the planner as our analyses of a system and then implied that the input to these analyses were without error and the results were absolute. We might have advised the planner that the maximum height of a dam to provide safety from ravages of nature and the greatest benefit to mankind was "x" feet to the nearest one-hundredth of a foot, even though this result may have been based upon a very small and inconsistent data set and poorly defined operational criteria. I think of the new philosophy as being one where we can, with proper and accepted techniques, evaluate the data set for consistency, evaluate criteria as to the physical and economical feasibility, and present to the planner far more alternatives where each of the alternatives would have meaningful measures of our confidence in our analyses.

You are aware of the abundance of literature concerning advanced techniques and new philosophies in hydrology. This literature is available from several sources - the predominant source being that of various university research programs. In this literature you can find intricate and rigorous proof of these techniques and elaborate hypotheses of the new philosophy, but little about the actual application to the problems of the real world.

A major part of our effort in experimenting with new techniques, most of which are found in the aforementioned literature, has resulted in a model that is used in studying water resource systems. This model was designed to accommodate the conjunctive use of both surface and subsurface water resources.

The model has essentially five main functional aspects. The computer application of this model was constructed such that any of the five aspects can be studied as separate analyses or can be combined as one analysis.

A logical point to begin the discussion of this model would be the functional aspect of data analysis. This aspect, which is the first block in our computer application, incorporates techniques such as those required in decomposing a discrete time series. The discrete time series being for the most part subsets within the input data set and representing such data as runoff, precipitation, temperature, chemistry, and etc., where the time increment is usually 1 month. Other statistical techniques are also incorporated as part of this functional aspect. We use this block to determine measures of information contained within each of the input data subsets, levels of confidence related to this information, trends, and inconsistencies as concerned with the homogeneity of the

series. From this block, we can also obtain the mathematical expressions and parameters necessary to generate, if required, larger periods of information.

The next functional aspect we might discuss is that which concerns the mathematical simulation of the operational characteristics of the water resource system. This block could be considered analogous to the previously mentioned reservoir operation studies. We have designed the computer application of the simulation such that with use of parameters, one can study different water resource systems without materially modifying the language of the computer application. Disciplines or objectives, such as irrigation, M&I, power, flood control, recreation, and water quality, can have assigned priorities in the simulation of the operational characteristics of the water resource system.

The simulation block or functional aspect is the "guts" of our whole water systems analysis application and, consequently, is the largest in physical size. Because we have designed this model as a conjunctive use model including water quality as a discipline, we have incorporated, among other things, the simulation of water percolating down through a soil column to predict chemical exchanges between soil and solution. A subsidiary subblock to the simulation is a control block which incorporates the criteria of a system operation as a series of constraints. I have made the explanation of the simulation block very brief; however, the functional aspect is simply to provide physically feasible solutions for the study of a particular water resource system.

After we have obtained how ever many physically feasible solutions we may require, we enter the next functional aspect which simply ranks the impact of priority of one objective or discipline upon all other objectives one may have included in a particular system. This ranking is further modified with respect to confidence levels of data pertinent to the simulation of this objective. A sensitivity analysis is also incorporated and this is simply an arbitrary variance of the first and second moments obtained for pertinent data subsets in the data analysis block. This particular functional aspect is used to maximize information and minimize efforts required for the subsequent blocks or functional aspects. It is with the use of this block that we have found that some of the studies of various water resource systems of the real world, imposed constraints, political and otherwise, have limited the degrees of freedom in such a manner that the use of our remaining functional aspects of this model become redundant or exercises in futility.

Our impact study realistically determines the number and size of the objective function we are to use in this functional aspect, which is simply an optimization technique to determine optional solutions for our study with the introduction of cost parameters.

The final functional aspect is one that uses a technique which can be considered analogous to "dynamic programming." It is in this block that we attempt to find the best plan, the next best plan, and etc., in the operation of our water resource system.

The model I have just briefly discussed is by no means in a final form. With our continued experimentation with new techniques and new philosophies, I am sure we will change many parts of the model.

The model has served us well as a base to build upon because in evaluating and experimenting with new techniques and philosophies you must start somewhere with real world applications and the important thing is to start. In applying this model, we have found how easy it is to become engaged in practicing the extreme of "driving a tack with a sledge hammer." We have also found that some of the intuitively designed best plans of a water resource system are very good and the use of our model does not add any significant improvement.

A few of our other efforts are in the experimentation of various techniques applicable to routing studies, prediction of sediment loads, and the digital modeling of aquifer simulation.

COMBINING NEW TECHNIQUES AND COMPUTER TECHNOLOGIES
FOR PROBLEM SOLUTIONS IN HYDROLOGY

Discussion

Question, Mr. Beard: In view of the variety of definitions of water resource systems, what is the general scope of the model you have developed? In particular, does the model simulate all water resources development features that the USBR is interested in?

Reply, Mr. Cristofano: The Bureau of Reclamation in their studies of water resource systems is becoming more involved in the total environment concerned with the system; therefore, the model I have developed does in simulation consider such features as irrigation, power, flood control, water quality augmentation, reservoir stratification with respect to temperature, and salinity balances as obtained by the best use of surface and subsurface water resources within the system. Constraints of water resource levels can be made applicable to recreation requirements if such are necessary.

Question, Mr. Peters: How do you handle the linearizing assumptions required for the linear programming algorithm?

Reply, Mr. Cristofano: I assume from this question that you are interested in knowing how the model accommodates nonlinear relationships that might have to be transformed for the linear objective function. From our experience, we have found that the levels of confidence related to various cost parameters are such that the nonlinearity can be handled by simply reducing the time frame such that a linear objective function can be approximated. Often times such approximation is not warranted on the basis of the low levels of confidence usually found in cost parameters.

Question, Mr. Fredrich: Does the simulation model have the capability to assign to each component in a system (based on the relative state of the component) an output quantity so that the sum of the outputs will equal a specified system requirement?

Reply, Mr. Cristofano: The simulation model actually divides the water resource system into several subsystems; each of the subsystems being called a node. In simulation, these nodes are in themselves entities and the capability assigned to each component within the node and its interface with any other node of the system is such that the output quantity from the node is a zero sum or, in effect, a balance. The output quantities of each of the nodes are again summed to insure that a particular system objective has been met.

Question, Mr. Eichert: What water quality parameters are considered in your model? Is complete mixing assumed or can vertical zones be used? What routing interval is used?

Reply, Mr. Cristofano: The model has two distinct mixing modes. One is the mixing as a result of the ionic exchange between soil and solution as water percolates down through a soil column and into an aquifer. This mixing is simulated by maintaining an ionic balance between soil and percolating waters which is governed by physical concepts of ionic exchanges. The mixing in this mode is complete and can be simulated for as many vertical zones as there are nodes. Each vertical zone can be divided into as many as 10 horizontal slices (two-dimensional flow). The horizontal slices are used to simulate lateral transmissions.

The second mode of mixing is that of water (solution) only. In this mode, mixing can be simulated as complete or incomplete and linear or nonlinear, and is used to simulate surface water mixing and lateral transmissions of subsurface waters.

The water quality parameters considered are those that are not inert and can be as many as 10 constituents; i.e., anions and cations, as long as a balance is maintained between the anions and cations. The routing interval is varied and can be a 1-hour interval to an annual interval and is specified by an index as part of the input. From this index, the model has accommodations to do the required dimensioning.

Question, Mr. Price: How large a system can your model handle? Can you handle reservoir stratification?

Reply, Mr. Cristofano: The system is presently designed to accommodate 100 subsystems within the water resource system. Each of the subsystems is called a node, and is defined as being an entity with an interface to any other subsystem as well as a whole system. However, from experience in using the model and input data available, it has been found that the model is far more accommodating in capacity than present water resource systems require. The model has a capability of simulating reservoir stratification insofar as temperature gradients are concerned. These temperature gradients are represented as mathematical expressions designed for a time frame of 1 day. The model does not make an attempt in mathematical concept to define all parameters one could conceivably use in simulating temperature gradients but uses instead statistical inference on the basis of data available and the objective impact of such data.

Question, Mr. Matthews and Mr. Beard: Is program (model) documentation available? When?

Reply, Mr. Cristofano: At the present time, we anticipate a fairly thorough documentation of the mathematical model, and in this respect, we do not intend to document the computer application. The model as designed is composed of 30-odd subroutines which can be linked to represent a water resource system using all features of the model or any part thereof. This model has been developed over the past 3 years with funds from the Water Quality Office in conjunction with the Bureau of Reclamation. I assume then that the Water Quality Office will have major responsibility as to when and if such documentation will be available.

Question, Mr. Fredrich: After simulating the physically feasible alternatives, the variables to be included in the objective function for the optimization process must be selected. Are the selections of the variables made by the computer or by the engineer-user?

Reply, Mr. Cristofano: The selection of the variables used in the objective function are made by the computer on the basis of ranking each of the objectives by the engineer-user. Further refinement in the selection of these variables by the computer is based upon the level of confidence obtained from the data analysis block of the input data applicable to the particular objective.

THE NEED FOR AND DEVELOPMENT OF A COMPUTER
PROGRAM FOR RE-ESTABLISHING LOW FLOW NAVI-
GATION REQUIREMENTS ON THE APALACHICOLA
RIVER

by

HERLON D. PIERCE¹

My presentation will not deal to great extent on a computer program, but with the need for and results of a program developed to study low flows on the Apalachicola River. In order for this discussion to be meaningful it will be necessary to present a background on the planned development and development to date on the Apalachicola, Chattahoochee and Flint Rivers. I will try to show this in relation to the time effect on the planned development of low flows on the Apalachicola River, and how computer studies were made to develop operating procedures that would re-establish the frequency of low flows to design frequency.

The existing project for the Apalachicola, Chattahoochee and Flint River as authorized by Congress in the River and Harbor Acts of 1945 and 1946, provided for a three stage plan of development for the basin. The overall plan for navigation was to provide a channel depth of 9 feet with a minimum width of 100 feet from the Gulf Intra-coastal Waterway through the Apalachicola River to Columbus, Georgia, on the Chattahoochee River and Bainbridge, Georgia, on the Flint River.

As was previously mentioned basin development was provided for in a three stage plan. The initial stage of development, consisting of the construction of Jim Woodruff Lock and Dam, provided navigation upstream to near Columbia, Alabama, on the Chattahoochee River and to near Bainbridge, Georgia, on the Flint River. Navigation on the Apalachicola River below Jim Woodruff was to be provided by open channel methods. The second stage provided for the extension of navigation on the Chattahoochee River upstream to near Columbus, Georgia, with the addition of the Columbia and Walter F. George Locks and Dams. Buford, a storage-power dam, located above Atlanta, Georgia, was included in this stage for multiple reasons one of

1 Hydraulic Engineer, Reservoir Regulation Section, Mobile District

which was to increase low flows in the Apalachicola River, thereby reducing maintenance dredging required for open-river navigation. The third stage assumed full basin development.

Principal Purposes	Stages of basin development			
	River	Stage I	Stage II	Stage III
Storage-Power	Chattahoochee		Buford	Buford
Storage-Power	Chattahoochee			Cedar Creek (1)
Storage-Power	Chattahoochee			Franklin (1)
Storage-Power	Chattahoochee			West Point
Navigation-Power	Chattahoochee		W.F.George	W.F.George
Navigation	Chattahoochee		Columbia	Columbia
Storage-Power	Flint			Spewell Bluff
Storage-Power	Flint			Lazer Creek
Storage-Power	Flint			Lower Auchumkee
Navigation-Power	Apalachicola	Jim Woodruff	Jim Woodruff	Jim Woodruff

(1) Not yet authorized - approved as a part of the general plan.

The effects of the various stages of development on low flow frequency downstream of Jim Woodruff can be shown from data developed in the original studies. These effects are shown in the following table.

Flows on the Apalachicola River for various stages of development

Flow	Stage I	Stage II	Stage III
Minimum flow	5,150	7,400	10,100
% of time 9,300 cfs will be available	86%	95%	100%

The 9,300 cfs is shown because the project as presently approved for improvement of the Apalachicola River calls for dredging and snagging to provide a navigable channel 9 feet deep at a flow of 9,300 cfs. Studies showed that a flow of 9,300 cfs could be expected 95% of the time and that the expected minimum flow of 7,400 cfs, minimum flow at the completion of stage II, would provide a channel 7 feet deep.

Jim Woodruff completed in 1957 initiated development of the basin. Stage II was achieved with the completion of the Walter F. George project in early 1963, and since that date no projects in stage III have been completed.

After the initial dredging and snagging of the Apalachicola River channel it was found to be impossible to maintain project depth throughout the low-flow season, June to December, each year. Depending on the status of maintenance dredging at the time, flow requirements to maintain a 9-foot channel vary from about 13,000 cfs to 17,000 cfs. Another factor that is important at this point is the fact that flow augmentation was an authorized purpose at Buford, however, in the authorization and planning stage flow augmentation was not set as a requirement but as a benefit which resulted from power operations. Initial and study power requirements from Buford set minimum weekly energy requirements that were used in evaluating the effects of power operations on low flows on the Apalachicola River. The effect of these operations on flows on the Apalachicola River can be seen by comparing flows at the completion of stage I and II as shown in the above table.

The original power contract for Buford was followed closely from the time of its completion in 1958 until the completion of Walter F. George in 1963. With the addition of Walter F. George into the power system a new contract was drawn up for the entire South Atlantic Division power system, which included projects in two separate Districts and three river basins. The studies for the system power contract were made by the Southeastern Power Administration and did not include flow augmentation from Buford as a requirement. Each project included in the system was allocated what was considered to be its share of the total energy sold in this contract for scheduling purposes. The monthly distribution of total annual energy at Buford was near the distribution specified in the original contract, therefore, it was assumed that the original flow analysis as shown earlier for stage II would be valid. As would be expected, in operating the power plants on a system basis very little weight was given to the weekly power values allocated to the individual projects. As a result, low flow augmentation did not occur as assumed in the original low flow studies for stage II. During the period 1963 through 1968 flows of less than 9,300 cfs occurred approximately 11% of the time as compared to the 5% shown for stage II development. This was pointed out more sharply by navigation interests who complained that sufficient depths for profitable operations were not dependable and that variations in depths

from week to week were too severe to effectively use available depths in the river. As it became apparent that operating the reservoirs on a system basis for power would not augment flows in accordance with studies made during planning, the Mobile District's Reservoir Regulation Section decided that studies would be made to re-evaluate the status of navigation flows on the Apalachicola River and to examine what if anything, could be done to return low flows to design frequency.

After a limited study of flows for the 1963 through 1968 period and an observation of rainfall amounts and distribution during this same period, it was determined that a detailed study of the hydrologic data associated with the period was not necessary since this period was highly representative of normal conditions. It was further noted that the total weekly energy delivered from the Mobile District's projects was near the total allocated to these projects. It was concluded that because of this fact the Mobile District's reservoirs could be operated as a sub-unit of the overall power system, and studies would be made to develop operating procedures for the most advantageous distribution of the allocated power amounts among the projects for the benefit of navigation on the Apalachicola River. As is apparent the two most important restraints in any study would be the Mobile District's share of total allocated energy and capacity since these values had been sold as part of the overall Southeastern Power Administration's contract for the South Atlantic Division power projects.

Although there were several alternatives to the type of study that could be made, facts surrounding the problem indicated that the study should include all the Mobile District power projects even though some of the projects do not directly affect low flows on the Apalachicola River. The study, while meeting all power requirements, strives to establish the best power distribution at any given time to return the frequency of low flows to as near that established for stage II development as practical.

At this point it might be wise to review some of the physical factors of the projects involved.

a. Jim Woodruff Lock and Dam, located just below the confluence of the Chattahoochee and Flint Rivers, was designed principally to provide for navigation on the Chattahoochee River to the vicinity of Columbia, Alabama, and up the Flint River to near Bainbridge, Georgia, and to produce hydro-electric power. The 108 miles

of open river channel between the dam and the Gulf of Mexico has a total fall of about 40 feet and navigable depths are dependent on a continuous flow. For this reason the Woodruff power plant is operated as a run-of-river project that utilizes its limited usable pondage of up to 2 feet for re-regulating variations in inflows caused by the operation of upstream power plants.

b. Columbia Lock and Dam on the Chattahoochee River 47 miles upstream from Jim Woodruff is a navigation project. Columbia is operated to provide navigation depths upstream to Walter F. George Lock and Dam, and to re-regulate the outflow from peaking power operations at the Walter F. George powerhouse. It has no usable storage but regulation narrows the range of daily discharge for the benefit of navigation in the upper reaches of the Jim Woodruff pool.

c. Walter F. George Lock and Dam, a multiple-purpose power-navigation project, is operated to provide navigation depths upstream to near Columbus, Georgia, and for the generation of hydroelectric power. The 244,000 acre-feet of seasonally available storage can be scheduled for use as required for power operations.

d. Buford Dam, located 274 miles upstream from the Walter F. George project, is a multiple-purpose flood-control-power project. It has 1,050,000 acre-feet of usable storage below the top of power pool. Since Buford does have a large amount of storage it becomes the most important project in the Apalachicola River system as far as flow augmentation is concerned.

e. Allatoona Dam, located on the Alabama River system, a storage power project, adds nothing to navigation on the Apalachicola River, but is a part of the Mobile District's power system. Having it in the system permits greater flexibility in scheduling releases from Buford and George.

The study program consists of weekly routings of flows for a 40 year period through the district's power plants with the objective to utilize the storage at these plants for the benefit of navigation while delivering the Mobile District's allocated power requirements. At all reservoir sites flows were converted to natural flows.

All releases are made through the power plants and all power scheduling is on a weekly basis. The maximum generation at any project is that plant's capability for the 100 peak hour period, while the minimum is plant capability for a 10 hour period. Pool restraints

such as top-of-power pool and minimum operating pool are observed, and in addition, zoning is included to maintain proportioned storage balance among the reservoirs.

The program begins by comparing the inflow at Woodruff to the 9,300 cfs. The discharge at Walter F. George is then reduced or increased as the case may require to give a minimum of 9,300 cfs and a maximum of as near 9,300 cfs as possible. Buford's discharge is then computed in an attempt to hold the Walter F. George pool within prescribed operating limits. The pool levels at Walter F. George and Buford are then computed and their discharges re-adjusted, if necessary, to hold the pool levels to within prescribed operating limits. The Allatoona generation is then set at a minimum, which is that needed to keep the pool from exceeding top-of-power pool elevation. The total generation at Walter F. George, Buford and Allatoona is then compared to the total allocated to these projects. In the event the total generation is not as great as that allocated, Allatoona is adjusted upward, as required, but within prescribed operating limits. If the Allatoona increase is not adequate Buford and George are adjusted upward, as required, in proportion to their respective discharge - generation relationships. In the event that the inflow at Woodruff is not equal to the target 9,300 cfs, the 2 feet of storage available at Woodruff is used as necessary to maintain the discharge of 9,300 cfs. At this point a generation of at least the amount of the allocated commitment and a flow of as near 9,300 cfs as possible is met. It is noted that during periods when excess energy is called for, to supply the 9,300 cfs, no attempt is made to reduce the energy computed to that allocated. Since the study shows that periods when excess energy is required are relatively few in number it was assumed that the excess energy from the Mobile District projects could be worked out within the overall system. Experience to date has shown this to be true.

As was mentioned earlier, design studies had indicated that with stage II development a flow of 9,300 cfs could be expected 95 percent of the time. By operating the reservoirs in accordance with the operating rules described, the flow of 9,300 cfs can be maintained 100 percent of the time. While this does not provide project depths of 9 feet as the original design studies anticipated, it does permit year-round navigation at depths which are profitable for the operators. Depending on the status of maintenance dredging this flow will provide 7 to 7.5 feet of water in the channel.

Since project depth can not be maintained with the 9,300 cfs, several alternative flow requirements greater than 9,300 cfs were investigated. It was found that none of these were acceptable primarily because of the power requirements imposed by the Southeastern Power Administration's power contract. These investigations showed that any appreciable increase in flow augmentation would violate the annual distribution of energy and jeopardize capacity requirements specified in the contract.

Although the design frequency of low flows were returned through this study the frequency of project depth was not returned. As a result of channel depths not being as originally believed, a program of channel improvement was undertaken. This recently completed channel improvement program consisted of contraction works and channel realignment. Early investigations after completion indicate that the dikes have helped some, and it is expected that considerable improvement will be evident by the next low flow season. Although the river should continue to improve over the next several years, it is expected that the major results of the channel improvement program will be seen by the low flow season of calendar year 1972.

In addition to channel improvement further improvement will be seen with the addition of phase III projects. These projects were described previously and one, the West Point project, is under construction. It is expected that with the completion of West Point, in early 1973, studies will be made by the Southeastern Power Administration which will include West Point in the Power system. Before approval of a new power contract the Mobile District will evaluate the effects of the contract on low flow augmentation. It is believed that low flow augmentation will be greater than anticipated in design studies if the new power contract is not too restrictive.

The district is also investigating the possibility of building a series of low head dams on the Apalachicola River. Future planning of these projects will depend to large extent on the success of the channel improvement project, on timing of phase III development and future power contracts. Early completion of phase III and the inclusion of navigation requirements in future studies for power contracts would alleviate to a large extent the problem of navigation on the Apalachicola River.

It might be interesting to you to know that the program as developed for the low-flow frequency study has been expanded to

include other restraints inherent in the operations of reservoirs, and is now known as the Mobile District's reservoir system program. The program has been used for an overall study of the system with historical flows and has been modified to use current and projected flows to set up weekly operating requirements and for short range planning.

This particular program was chosen as the subject because it shows how the computer can be used to evaluate the effects of new restraints or restraints which have not been fully considered (such as SEPA's failure to properly consider flow augmentation) to a portion of an overall system if certain precautions are taken. It also points out the need for a coordinating body, such as a Reservoir Control Center, for making and evaluating overall reservoir system studies to assure proper consideration of all project functions.

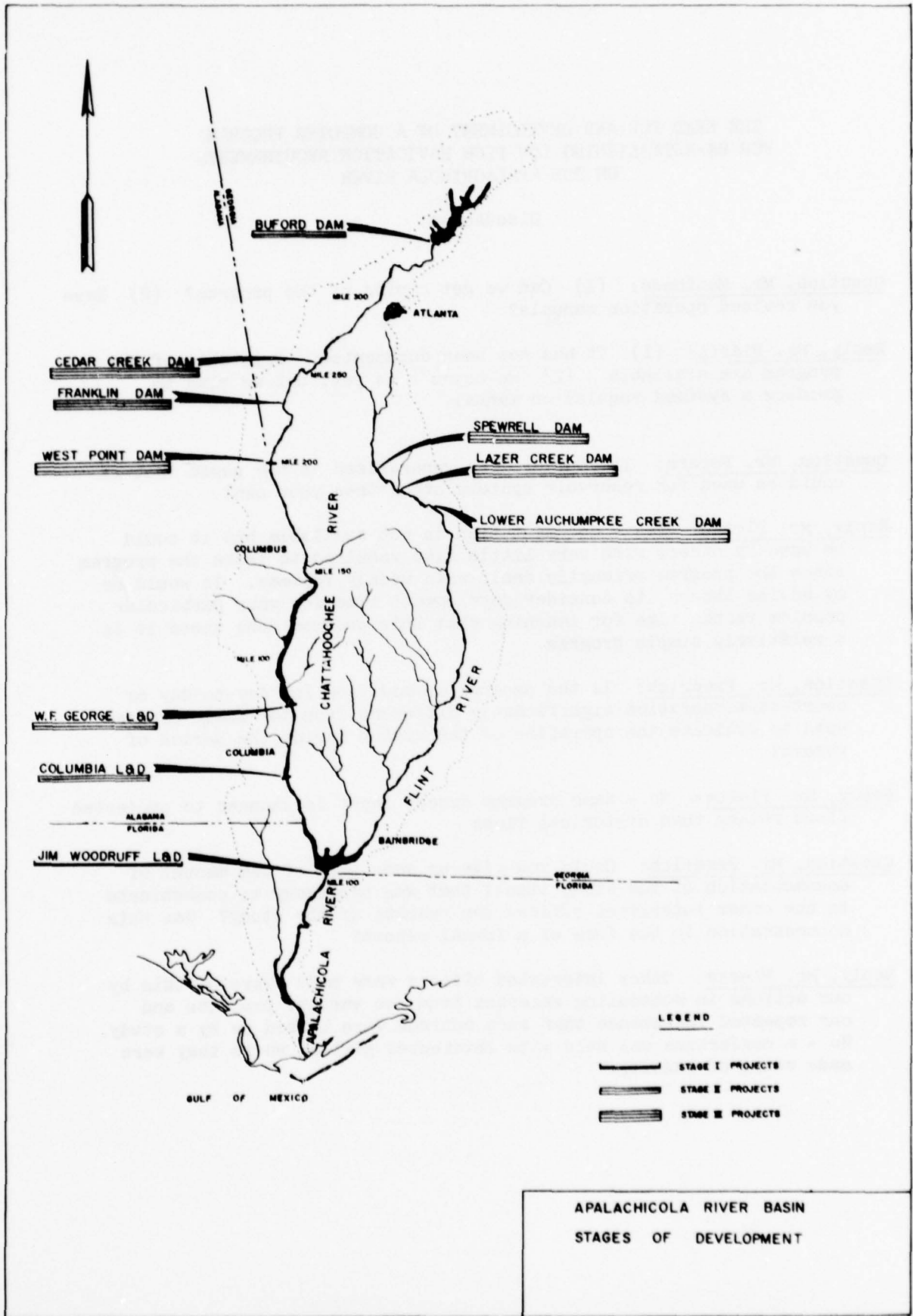

APALACHICOLA RIVER BASIN
STAGES OF DEVELOPMENT

THE NEED FOR AND DEVELOPMENT OF A COMPUTER PROGRAM
FOR RE-ESTABLISHING LOW FLOW NAVIGATION REQUIREMENTS
ON THE APALACHICOLA RIVER

Discussion

Question, Mr. Matthews: (1) Can we get copies of the program? (2) Have you revised operation manuals?

Reply, Mr. Pierce: (1) It has not been documented. Printouts of the program are available. (2) We haven't as yet, but we plan to produce a systems regulation manual.

Question, Mr. Peters: Is your program generalized in the sense that it could be used for reservoir systems other than your own?

Reply, Mr. Pierce: Yes - documentation is not available but it could be used by others with very little time required to learn the program since the program primarily deals with weekly volumes. It would be my advice though, to consider development time for your particular problem vs. the time for learning what this program does since it is a relatively simple program.

Question, Mr. Fredrich: Is the program as modified for day-to-day or short-term operation significantly different from the basic program used to evaluate the operation of the system during the period of record?

Reply, Mr. Pierce: No - same program except input is changed to projected flows rather than historical flows.

Question, Mr. Fredrich: Could you give us some idea of the amount of documentation of the study itself that was necessary to communicate to the other interested offices the results of the study? Was this documentation in the form of a formal report?

Reply, Mr. Pierce: Other interested offices were made aware of this by our actions in scheduling releases from the various projects and our repeated insistence that such actions were backed up by a study. No - a conference was held with interested parties where they were made aware of results.

COMPUTER USE IN REGULATING THE OHIO RIVER PROJECTS

by

James S. Matthews¹

INTRODUCTION

Regulation of reservoirs and navigation dams using computers began in the early 1950's. Major improvements have paralleled refinements in computer hardware.

The goals of the computer programming effort in the Ohio Basin are:

- a. Prevention, or reduction, of flood damages through effective regulation of the reservoirs now operational. (Plus incorporation of new projects as they become operational.)
- b. Seasonal regulation of multi-purpose pools to insure the timely utilization of available storage with optimum effectiveness among purposes.
- c. Continuing monitoring of the projects with a view to improving regulation through new procedures and operating guides. Those improvements may also include realignment of storages dedicated to the several uses as the Reservoir Control Center staff matures functionally and procedures become more sophisticated.

The Ohio Basin Corps of Engineers system of improvements includes ninety-six (96) major lakes and reservoirs. Fifty-six of those are completed; twenty-four (24) are under construction; five (5) are in the land acquisition phase; and planning is underway on eleven (11). They range from the simplest "dry pool" detention structures to some of the most complex multiple purpose projects in the nation. Effectively regulating reservoirs with purposes of flood control, power, navigation, quality control, water supply, recreation, and fish and wildlife (upstream and down) presents quite a challenge. The seventy-four (74) completed local protection projects, along with the at least twenty (20) which will be completed in the next decade, add to the complexity of the problem.

A second major area of shared responsibility of the Center is the regulation of the navigation system along the 981 mile canalized Ohio River. Flow forecasts provide guidance for manipulating the navigation dams to improve water quality and to extend "Open River" conditions at the movable structures.

An area of great responsibility is the coordination of discharges at Barkley and Kentucky Dams during threat of flooding on the lower Ohio and Mississippi Rivers.

¹Hydraulic Engineer, Reservoir Control Center, Ohio River Division

This paper discusses the hardware and software now being used in ORD along with future plans. It contains brief references to allied manual routing procedures which are used as a first estimate and will later be incorporated as a back-up procedure. The area covered is primarily that of the functioning of the Reservoir Control Center in ORD, Cincinnati, Ohio.

HARDWARE

Hardware in ORD

a. The Central Processing Unit of the recently expanded ADP Center of ORD is a General Electric 425 Computer. The unit capacity is 32K., or 32,000 - 4 character - 6 bit words of core. There is a proposal to increase the core storage to 64K. The unit has been in place since September 1970 and is still somewhat in the "shake down" stage.

The "Job-Stack" Processor, through previously designated priorities can automatically select candidates (jobs) for execution by the machine. Assuming that one or more jobs being processed leave ample remaining capacity; the Processor will sort through the stack; locate a job and start processing (or programming) it through the C.P.U. Thus the system has multi-programming capability, or ability to do two or more jobs at a time.

b. The peripheral hardware includes a nine disc storage unit. The DSU 167 contains three - 3 spindle units, eight discs can be in use at a time. Each disc has 11 platters containing 20 recording surfaces. There is a storage capacity of 15 million characters per disc. There are three magnetic tape controllers.

The present center includes a 1,200 lines per minute (numerical) printer, a card reader, an automatic card punch and several manual card punch machines.

c. The Terminal Control in the ADP Center is made up of a Datanet 30 Unit. The terminal can communicate with satellites without destroying efficiency. A smaller satellite terminal has been installed in the RCC for direct phone communication with the ADP Center hardware.

Hardware in Districts

a. Each of the four Districts has a Central Processing Unit (G.E. 225) with 8 K-3 character words - storage. They generally have a card reader, printer, card punch and 2 tape drives. All units are smaller units than those in the ADP Center. The C.P.U is designed principally to communicate with G.E. 425 in ORD.

SOFTWARE

Software in Use in ORD

There are five (5) programs now in use in the Reservoir Control Center. They include a program for reservoir heat budget analyses of reservoirs

developed by Water Resources Engineers, Inc. (WRE) of Walnut Creek, California. That requires more storage than the G.E. 425 now has. There is a Muskinqum flood routing program used in our damage - benefit analysis of projects which was developed in ORD. We have three (3) programs used in the regulating of reservoirs and navigation dams.

a. The principal daily routing program includes the routing of flows from Dashields, Pennsylvania to Metropolis, Illinois, through eleven (11) reaches. The program utilized storage routing techniques in which the travel time of the flood wave is approximately made equal to routing time. Five-day discharge forecasts are calculated for eleven (11) points on the main stem.

Five-day forecasts for twenty (20) inflow points which represent the major tributaries to the Ohio River are furnished daily by the Districts.

Releases at two of the points, the Cumberland River at Barkley Dam and the Tennessee River at Kentucky Dam, are determined by ORD during high flows on the lower Ohio or Mississippi Rivers.

The program may be initiated at any reach. This is especially important when trying to determine the optimum release schedule for Kentucky and Barkley projects that will give the greatest reduction in stage at Cairo, Ill. and still retain sufficient storage to control the next flood event. There are four sub-routines which support the main program:

(1) Sub-routine Xcess calculates rainfall excess over a drainage area. Program input consists of a code designating a particular drainage basin or local area; the antecedent precipitation index for the basin; and, the rainfall quantity at selected stations considered representative of the basin.

Data files are created that contain rainfall distribution factors for each station as it applies to a particular drainage area. From this an average rainfall is estimated. Yesterday's estimate of the moisture condition (API), averaged for the season of the year, is reduced by a factor of 0.9. A search of data files containing the National Weather Service Coaxial Rainfall Runoff Chart for the Ohio River Valley, together with associated calculations results in the rainfall excess as output from the sub-routine.

(2) Sub-routine Untgr calculates distribution of the flow from a drainage basin using output from the previous sub-routine.

Data files containing the unitgraph values for specified time increments are accessed and a flow distribution pattern is calculated. Applying the principle of superposition, the residual of yesterday's hydrograph is added to today's runoff to give the total flow graph for the drainage area. Output from the sub-routine is then transposed into the main program.

(3) Sub-routine CCLC may not be accessed depending upon the reach in which the flow forecast is being developed.

It inputs the District's tributary flow forecast and utilizing previous studies of past floods, lags or advances this forecast. A quadratic

equation is fitted to successive forecast flows and estimates of the flow at intermediate times is calculated. Newton's Forward Interpolational Formula is used to calculate the coefficients of the quadratic equation. Output from the sub-routine is then transposed into the main program.

(4) Sub-routine FCHEK is being developed to plot the preceding five-day observed hydrograph along with the five-day forecast using a Terminet 300 as the output device. This allows the hydraulic engineer to smooth the forecast based upon the previously observed data and experience gained from routing of previous flows. The smoothed forecast hydrograph is then input into the main program for routing through the next reach.

A preliminary estimate is made each morning by a modified Puls routing procedure developed through long years of observation. The computer routing is run to obtain the discharge forecasts used in regulating the system. This run is usually at mid-morning after District inputs arrive.

b. The Rating Program at Wicket Navigation Dam 52 was developed to aid in maintenance problems. It determines the amount of peak flow that could safely be released through Kentucky and Barkley turbines and still keep the movable dam up so that navigation will not be impeded.

c. The Reservoir Storage Analysis Program calculates reservoir storage and sums for each tributary basin and the Ohio Basin. Data giving the amount of storage utilized for flood control and the amount available for augmentation is calculated for each reservoir. The program is to be run daily as soon as the terminet is connected.

District Software

The four ORD Districts are using over sixty (60) general programs and sub-routines. They have goals which range from rainfall weighting to complex systems analysis. Many are in the developmental stage.

a. The Districts all use or are developing flow prediction programs. These programs are used to a greater extent on post flood studies. They are basically the application of the modified Puls Flood Routing procedures. The Muskinum routing procedure also has limited use in tributary routing.

The following sub-routines are parts of the total routing package.

(1) The weighted runoff routine includes Thiessen Polygon weighting procedures.

(2) The output from (1) is adjusted and applied to unit hydrographs to obtain flood hydrographs. One District uses sixty-one (61) sub-areas in their programs.

(3) The flood (outflow) hydrographs are input into the main program and the results are printed or punched using various sub-routines developed for different needs. This output contains outflows for desired reaches of a river or stream.

b. All of the Districts also have computer programs to perform design calculations for regulation of a single reservoir and/or routing of holdout hydrographs for one or more damage stations or reference reaches. These programs, or program combinations, can be modified for special routings, such as low flow augmentation.

PROGRAM NEEDS

The ultimate satisfier of regulation needs would, of course, be a complete program (mathematical model) of a basin or sub-basin which would be fed data from automated gages. The output would be accurate analyses of the system including recognition of critical points along the river and a listing of alternative schemes for system regulation to mitigate the hazards or meet water needs.

Program Needs in ORD

Needs of the RCC are principally in support areas. We feel that the basic programs already are sound. We are, however, working to expand and improve them.

a. Improved unit hydrographs from some tributaries are needed. In some cases sub-areas are being sub-divided into smaller true hydrologic units for improved accuracy. There is also a great need for improving main stem unit hydrographs.

b. Cover and geology of hydrologic units are being studied for more accurate estimating of seasonal differences in storm run-off. These also include studies to improve base flow estimates.

c. Ratings for gates at reservoirs and navigation dams are being refined by us and the USGS. Improved gaging and control are especially important during periods of extreme low flows.

d. Increased automation is planned, but for the immediate future, plans include only RCC plant improvements.

e. Coordination of activities with other Corps offices and federal and state agencies becomes more important as we strive for efficiency.

f. Our most pressing need is the completion of the adaptation programs for the new hardware. We will ultimately require much greater core for storage and execution than the G.E. 425 can provide. It is hoped, however, that the ADP Center can expand its facilities as our needs expand.

Program Needs of Districts

District needs are generally those of ORD. Most of them are working on the inputs to a routing program for an entire basin, such as the Cumberland or Monongahela. They are in varying stages of development.

a. Increased automation is an area in which the Districts hope to make major advancements soon. The availability of funds and cooperative efforts with the National Weather Service and U.S. Geological Survey will regulate.

We are very optimistic.

Summation of Needs

We are all striving toward the ideal already noted. To reach it will take several years and millions of dollars. However, there is much we can do to update and improve our efforts. Ohio River Division is striving to meet the challenge.

PERSONNEL NEEDS

We are all aware of the present budgetary constraints. There is, however, a need for staffing at most of the Districts and ORD. The ORD needs are for support staff to refine program inputs as outlined above. Some of the Districts need little change while others need almost entire new or retrained staffs.

DISCUSSION

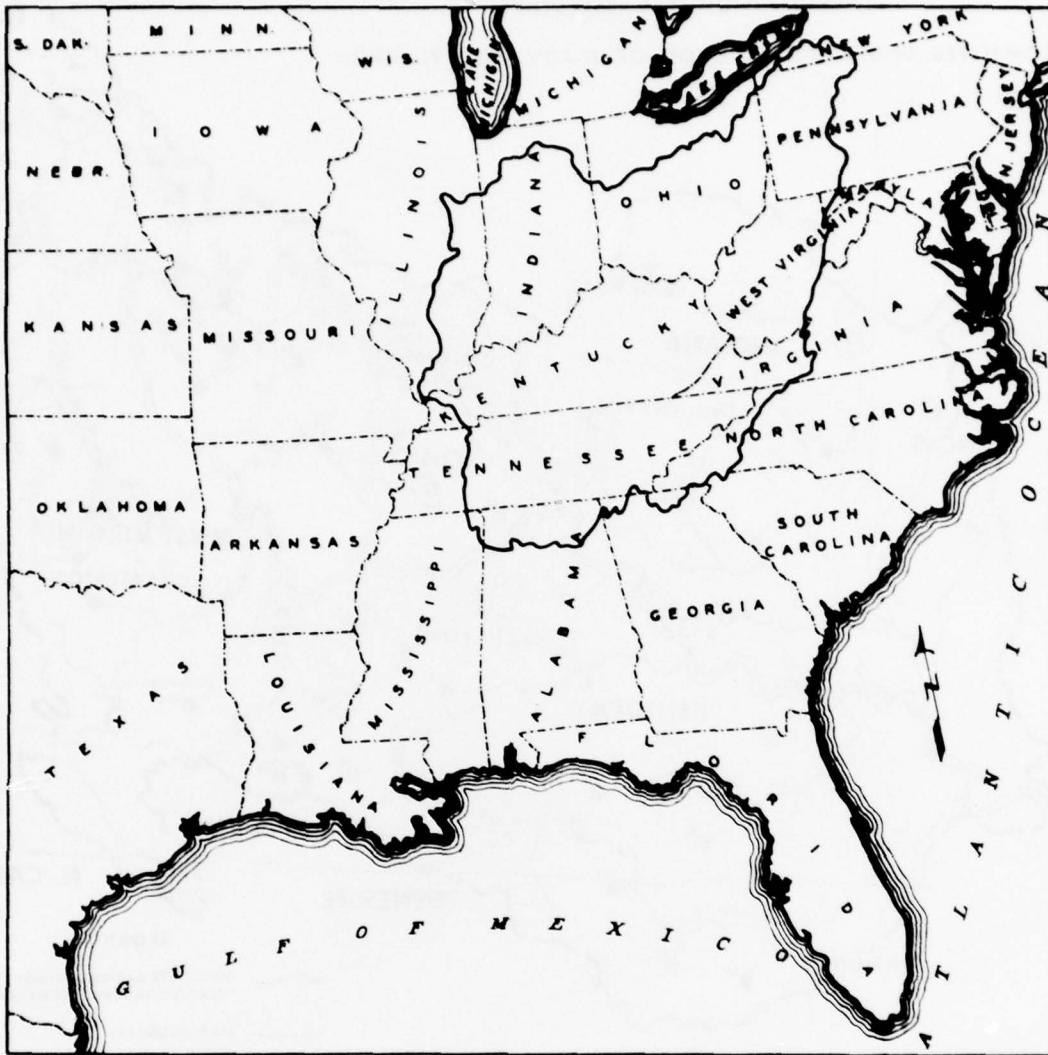

100 200 300 MILES
SCALE

FIGURE 1.

THE OHIO RIVER BASIN

**OHIO RIVER BASIN
CORPS OF ENGINEERS RESERVOIRS**

COMPLETED, UNDER CONSTRUCTION, OR IN ADVANCED PLANNING

MARCH 1971



FIGURE 2.

RESERVOIR STATUS

- EXISTING RESERVOIRS
- ◐ RESERVOIRS UNDER CONSTRUCTION
- RESERVOIRS IN ADVANCED ENGINEERING AND DESIGN OR LAND ACQUISITION

ALLEGHENY BASIN

- 1-ALLEGHENY
- 2-CONE MAUGH
- 3-CROOKED CREEK
- 4-EAST BR. CLARION
- 5-LOYALHANNA
- 6-MAHONING CREEK PA.
- 7-TIONESTA
- 8-UNION CITY
- 9-WOODCOCK CREEK
- 10-MUDDY CREEK

MONONGAHELA BASIN

- 11-TYGART
- 12-YOUGHIOGHENY
- 13-STONEWALL JACKSON
- 14-ROWLESBURG

BEAVER BASIN

- 15-BERUN
- 16-MOSQUITO CREEK
- 17-SHENANGO
- 18-M. J. KIRWAN

MUSKINGUM BASIN

- 19-ATWOOD
- 20-BEACH CITY
- 21-BOLIVAR
- 22-CHARLES MILL
- 23-CLENDENING
- 24-DILLON
- 25-DOVER
- 26-LEESVILLE
- 27-MOHAWK
- 28-MOHICANVILLE
- 29-PIEDMONT
- 30-PLEASANT HILL
- 31-SENECAVILLE
- 32-TAPPAN
- 33-WILLS CREEK
- 34-N BRANCH KOKOSING
- 35-UTICA

LITTLE KANAWHA BASIN

- 36-BURNSVILLE
- 37-WEST FORK
- 38-LEADING CREEK

HOCKING BASIN

- 39-TOM JENKINS

KANAWHA BASIN

- 40-BLUESTONE
- 41-SUMMERSVILLE
- 42-SUTTON

GUYANDOTTE BASIN

- 43-R. D. BAILEY

TWELVEPOLE CR. BASIN

- 44-EAST LYNN
- 45-BEECH FORK

BIG SANDY BASIN

- 46-DEWEY
- 47-FISHTRAP
- 48-J. W. FLANNAGAN
- 49-N FORK OF POUND
- 50-PAINTSVILLE
- 51-YATESVILLE

LITTLE MIAMI BASIN

- 52-GRAYSON

TYGARTS CREEK BASIN

- 53-KEHOE

SCIOTO BASIN

- 54-DEER CREEK
- 55-DELAWARE
- 56-PAINTCREEK
- 57-ALUM
- 58-BIG DARBY
- 59-MILL CREEK
- 60-SALT CREEK

LITTLE MIAMI BASIN

- 61-CAESAR CREEK
- 62-EAST FORK

LICKING BASIN

- 63-CAVE RUN
- 64-FALMOUTH

MILL CREEK BASIN

- 65-WEST FORK

MIAMI BASIN

- 66-CLARENCE J. BROWN
- 67-BROOKVILLE

KENTUCKY BASIN

- 68-BUCKHORN
- 69-CARR FORK
- 70-RED RIVER
- 71-BOONEVILLE
- 72-EAGLE CREEK

SALT BASIN

- 73-TAYLORSVILLE

GREEN BASIN

- 74-BARREN RIVER
- 75-NOLIN
- 76-ROUGH RIVER
- 77-GREEN RIVER

WABASH BASIN

- 78-CAGLES MILL
- 79-HUNTINGTON
- 80-MANSFIELD
- 81-MISSISSINAWA
- 82-MONROE
- 83-SALAMONIE
- 84-LAFAYETTE
- 85-LINCOLN
- 86-BIG PINE
- 87-CLIFTY CREEK
- 88-PATOKA
- 89-LOUISVILLE

CUMBERLAND BASIN

- 90-MARTINS FORK
- 91-BARKLEY
- 92-CENTER HILL
- 93-DALE HOLLOW
- 94-J. PERCY PRIEST
- 95-WOLF CREEK
- 96-LAUREL

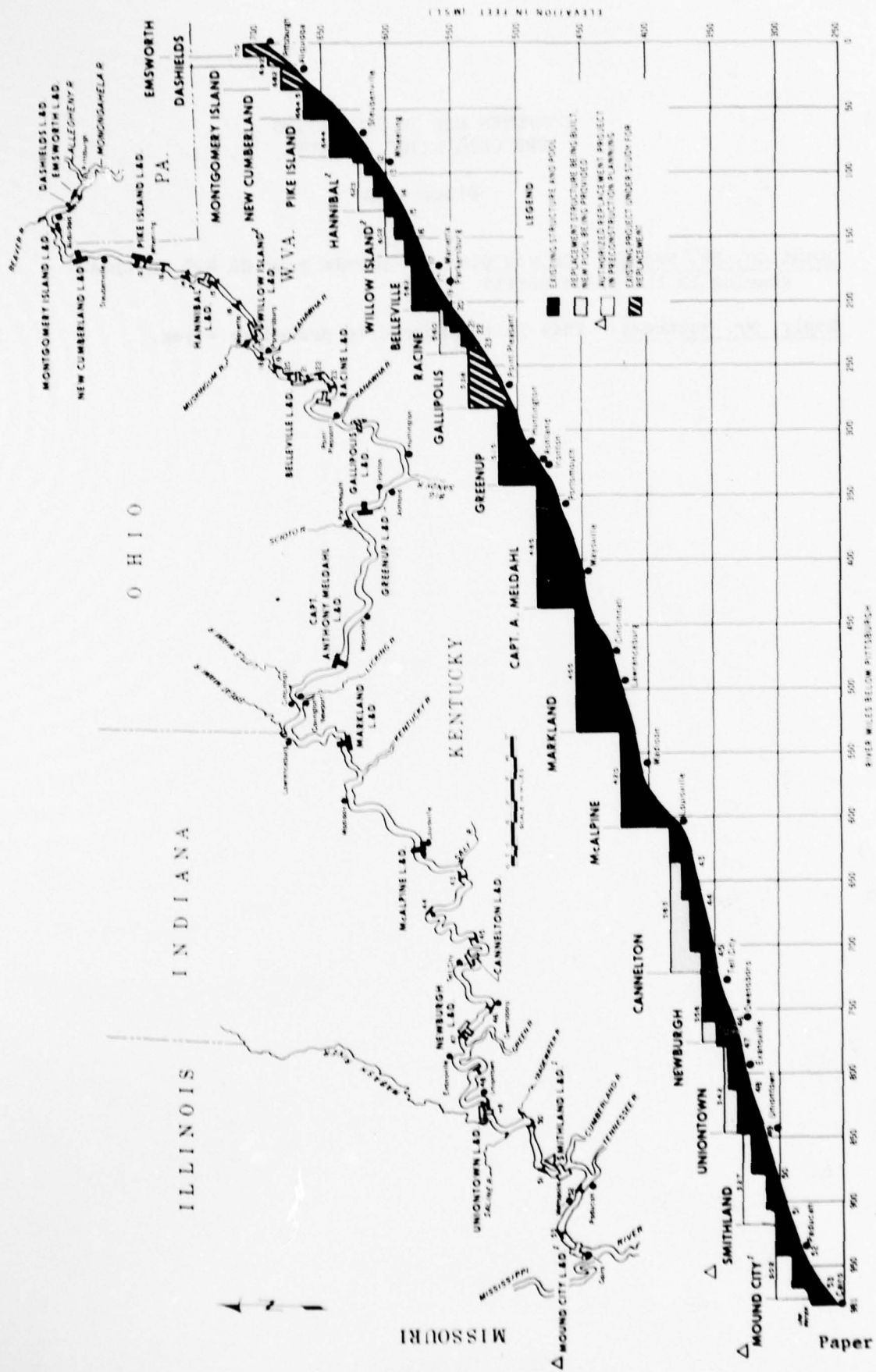

FIGURE 3.
OHIO MAIN STEM NAVIGATION SYSTEM

Map in July 1965 program. ENTIRE PRECONSTRUCTION STATUS AFTER THAT DATE.
Construction drawings after July 1965.

COMPUTER USE IN REGULATING
THE OHIO RIVER PROJECTS

Discussion

Question, Mr. Renner: Do you plan to operate your GE 425 on time-sharing in the prime shift?

Reply, Mr. Matthews: That is the agreed-to procedure - yes.

REGULATION OF COMPLEX RESERVOIR
SYSTEMS FOR FLOOD CONTROL

by

Saul Cooper¹

DESCRIPTION

The New England region covers an area of about 67,000 square miles, one-half of which is in the State of Maine. The region is comprised of many hydrologically different river basins, the largest being the Connecticut River which drains a little over 11,000 square miles. The Saint John River originates in Canada and has a total drainage area of 21,360 square miles of which 7,360 are in Maine. Many of the regions' larger river basins are located in Maine, however, because the state is sparsely populated, annual flood losses are small and to date no flood control reservoirs have been constructed with the exception of a small ice dam on the Narraguagus River. The same conditions generally prevail in northern New Hampshire and Vermont.

In southern New England the river basins are generally smaller, but more heavily populated with larger industrial, commercial and residential centers located in or adjacent to flood plains. Most of the Corps' 74 flood control projects are located in southern New England. Table 1 lists pertinent data on the flood control system by river basin and Table 2 lists pertinent data for each reservoir.

TABLE 1

<u>Basin</u>	<u>D.A.</u> (sq.mi.)	<u>Number of</u> <u>Reservoirs</u>	<u>Flood Control</u> <u>Capacity</u> (ac.ft.)	<u>Number of</u> <u>Local Protection</u> <u>Projects</u>	<u>Estimated</u> <u>Population</u> (1960)
Housatonic ⁽¹⁾	1,949	7	76,520	3	500,000
Connecticut	11,250	16	521,010	18	1,640,000
Thames	1,473	6	140,250	1	310,000
Blackstone	540	1	12,440	3	890,000
Merrimack	5,015	5	365,000	5	1,030,000
		TOTAL	1,115,220		

(1) All reservoirs in the Housatonic River basin are located on its most important tributary, the Naugatuck River.

¹Chief, Reservoir Control Center, New England Division

TABLE 2
PERTINENT DATA
NED FLOOD CONTROL RESERVOIRS

<u>Reservoir</u>	<u>River Basin</u>	<u>Drainage</u>	<u>Flood Control Storage</u>	
		<u>Area</u> (sq. mi.)	<u>Ac/Ft</u>	<u>Inches</u>
Sucker Brook	Connecticut	3.4	1,480	8.2
Northfield Brook	Naugatuck	5.7	2,350	7.7
Conant Brook	Connecticut	7.8	3,740	9.0
East Branch	Naugatuck	9.3	4,350	8.8
Hancock Brook	Naugatuck	12.0	3,900	6.1
Hop Brook	Naugatuck	16.4	6,850	7.8
Hall Meadow Brook	Naugatuck	17.2	8,620	9.4
Mad River	Connecticut	18.2	9,510	9.8
Black Rock	Naugatuck	20.4	8,450	7.8
Buffumville	Thames	26.5	11,300	8.0
West Hill	Blackstone	28.0	12,440	8.3
Hodges Village	Thames	31.1	13,250	8.0
Westville	Thames	32.0 (net)	11,000	6.4
MacDowell	Merrimack	44.0	12,800	5.4
Otter Brook	Connecticut	47.0	17,600	7.0
Tully	Connecticut	50.0	20,500	7.7
Littleville	Connecticut	52.3	23,000	8.3
Barre Falls	Connecticut	55.0	24,000	8.2
East Brimfield	Thames	67.5	29,900	8.3
Thomaston	Naugatuck	70.8 (net)	42,000	11.1
West Thompson	Thames	74.0 (net)	25,600	6.5
Surry Mountain	Connecticut	100	31,680	5.9
Townshend	Connecticut	106 (net)	32,800	5.8
Colebrook River	Connecticut	118	50,200	8.0
Union Village	Connecticut	126	38,000	5.6
Blackwater	Merrimack	128	46,000	6.7
North Springfield	Connecticut	158	48,500	5.8
Mansfield Hollow	Thames	159	49,200	5.8
Knightville	Connecticut	162	49,000	5.7
Ball Mountain	Connecticut	172	52,350	5.7
Birch Hill	Connecticut	175	49,900	5.3
North Hartland	Connecticut	220	68,750	5.8
Hopkinton-Everett*	Merrimack	446 (net)	155,600	6.5
Franklin Falls	Merrimack	1,000	150,600	2.8

* Two reservoirs when pool elevation is below 400 feet msl and one reservoir when pool elevation is 400 feet msl or higher

In addition, we have five local protection projects on four small coastal streams and four hurricane barriers along the southern New England coast. Because the flood plains along the main rivers are highly settled and developed, reservoirs had to be located on the small, steep tributaries. Our reservoirs range in size from 3.43 square miles to 1,000 square miles and 21 of them have drainage areas of less than 100 square miles. So you can see our projects are much smaller than in most Divisions. However, potential flood damages are very high as evidenced by the \$500,000,000 loss experienced in southern New England in August 1955.

The primary purpose of our reservoirs is flood control. Two of the projects have water supply storage, two have conservation storage and 22 have permanent water bodies which support water based activities. In earlier years, procedures for determining the amount of flood control storage indicated that 6 inches would be adequate. However, later studies following the 1955 floods indicated that in most instances 8 inches would be necessary, especially in southern New England. Therefore, most of our newer reservoirs have between 6 and 8 inches of flood control storage. The only exception is Franklin Falls reservoir which has 2.8 inches, controlling the runoff from 1,000 square miles, most of which drains the slopes of the White Mountains. At the time it was conceived in the early 1940's, it would operate in series with another upstream project. However, the other project was never built and so Franklin Falls is regulated with a constant outflow and the amount is dependent upon snow cover and flood volume.

TYPES OF FLOODS

The New England region is subjected to floods in all seasons of the year. The probability of a flood is greatest in the spring when the snowmelt occurs and the rivers are flowing at or near bankfull capacity for several weeks. Most of the minor and moderate floods, with the exception of tidal floods, occur during the spring runoff period and can encompass the entire region rather than a single basin. Of course, major floods also can occur during this period as in March 1936 when the entire region experienced record or near record floods. During the hurricane season, various portions of the region are exposed to all types of floods which depend upon the path of the hurricane. Floods ranging from minor to major can result from hurricane rains. Tidal flooding also is a major concern in the New England region and flooding can occur during hurricanes and severe coastal storms. Floods occurring in the fall after the foliage is gone are frequent and could be of sufficient magnitude or volume to fill the reservoirs. In the winter, floods ranging in size from minor to major have resulted from heavy rains with thaws which were preceded by freezing ground conditions and moderate amounts of snowfall.

DATA COLLECTION SYSTEM

A comprehensive data collection network has been established in order to operate the flood control system. Each dam is equipped with a voice radio for relaying data to and receiving instructions from the Reservoir Control Center. Each dam is responsible for obtaining data from a group of index stations either through cooperative observers or visual observations. This information usually consists of precipitation reports in the basin, climatologic and hydrologic data at the dam, certain river stages and general river conditions at strategic locations, both upstream and downstream of the dam. In addition, NED has a new Automatic Hydrologic Radio Reporting System which consists of 41 remote reporting stations. These stations report information such as reservoir level, river stage and/or precipitation. Two of the stations are used for the operation of hurricane barriers and report tide elevation, wind speed and direction, and barometric pressure. This system is under computer programmed control and data is received in about three seconds from each station. Programs developed to date to analyze the data will be discussed by Mr. Mirick. There is continuous communication by telephone and teletype with the U.S. National Weather Service and River Forecast Center for the exchange of information. Contact also is established with the USGS, the USCG and many other State and private agencies for pertinent flood information. RCC also coordinates snow sampling measurements with several Federal, State and private agencies to determine the water equivalent of the snowpack and issues on a weekly basis a bulletin depicting snow conditions in the region.

PRESENT REGULATION METHODS

Most of the NED reservoirs are regulated initially to reduce damaging stages on their respective tributaries and regulation usually is continued to afford reductions at main stem damage centers. In each basin the design height of local protective works is predicated upon a recommended system of reservoirs and in most cases the recommended system has not been completed. Until the early 1960's, we did not have enough reservoirs in a single river basin to exert a large amount of control. However, with the addition of 26 new reservoirs since the August 1955 flood, giving us a total of 35, we now can cause a substantial reduction in four of the five basins (Connecticut, Merrimack, Thames and Naugatuck basins) we regulate for flood control.

With 6 to 8 inches of storage at our projects we can regulate the reservoirs conservatively during minor and moderate floods and provide optimum reductions at downstream damage centers. There would be sufficient space in the reservoir to store the entire runoff during these types of floods and emptying could begin after the flood receded to safe channel

capacity. In a major flood with high runoff we might not be able to contain the entire runoff and without good forecasting and simulation techniques we may not achieve optimum stage reductions at downstream damage centers. All the major river floods (March 1936, September 1938 and August 1955) in New England were unusual but they had one element in common. Each was preceded by a series of storms that soaked the area with a large amount of rainfall and set the stage for rapid runoff from the next storm. Our regulation can be considered in three phases: (a) initial regulation for tributary damage centers, (b) continued regulation for main stem damage centers and (c) emptying the reservoirs after the flood peaks have passed by.

A few illustrations may help explain some of these problems.

Knightville Reservoir. This reservoir is located in the Westfield River, a tributary of the Connecticut River, and contains 5.7 inches of storage. Its drainage area of 162 square miles makes it one of our larger reservoirs. The project is regulated for protection to communities along the Westfield River and, in conjunction with other flood control reservoirs, along the Connecticut River. (See Plate 1). The index station on the Westfield River is in the city of Westfield where channel capacity is about 10,000 cfs for a drainage area of 497 square miles. Travel time from Knightville to Westfield is about 3 to 6 hours. The reporting network in the basin includes gaging stations on the Middle Branch (D.A. = 52 square miles), West Branch (D.A. = 94 square miles), and Westfield, and precipitation stations at the dam, Chesterfield and West Cummington. In the August 1955 flood, heavy rainfall was centered over the city of Westfield where a total of 19 inches was recorded in about 36 hours. The initial alerting report to RCC is received from the Dam Operator when one inch is reported from any of the rainfall stations. Alerting reports also are received when certain rivers reach specified stages. Because runoff in the Westfield can build up rapidly, regulation usually is started based on 2 or 3 inches of rainfall or predetermined rising river stages on the West Branch.

On August 18, over 3 inches of rain were recorded at Knightville dam in about 7 hours. (See Plate 2). This caused the initial rise and the gates were closed about noon on the 18th. Another 4.4 inches were recorded at the dam in 6 hours ending 0400 hours on the 19th and the peak inflow occurred at the end of the heavy rainfall period. The initial regulation of this project is based on what is actually happening on the Westfield River. By noon on the 18th, flows at the tributary index stations reached operation stages so Knightville gates were closed. There was not a big enough drop in stage on the night of the 18th to begin opening the gates and so when the heavy rainfall occurred during the night

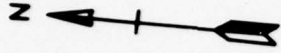

WESTFIELD RIVER WATERSHED

KNIGHTVILLE DAM

LITTLEVILLE DAM

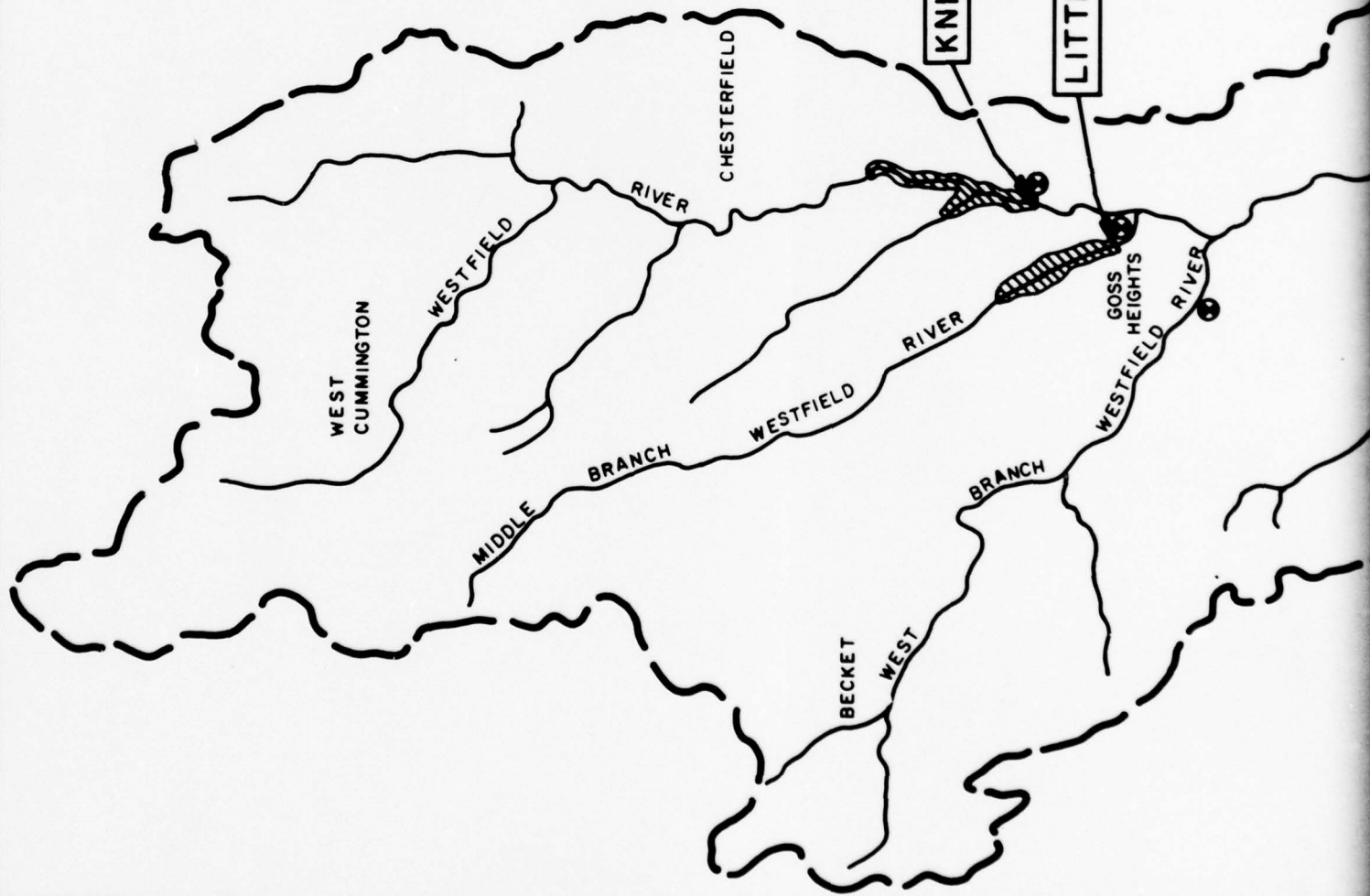

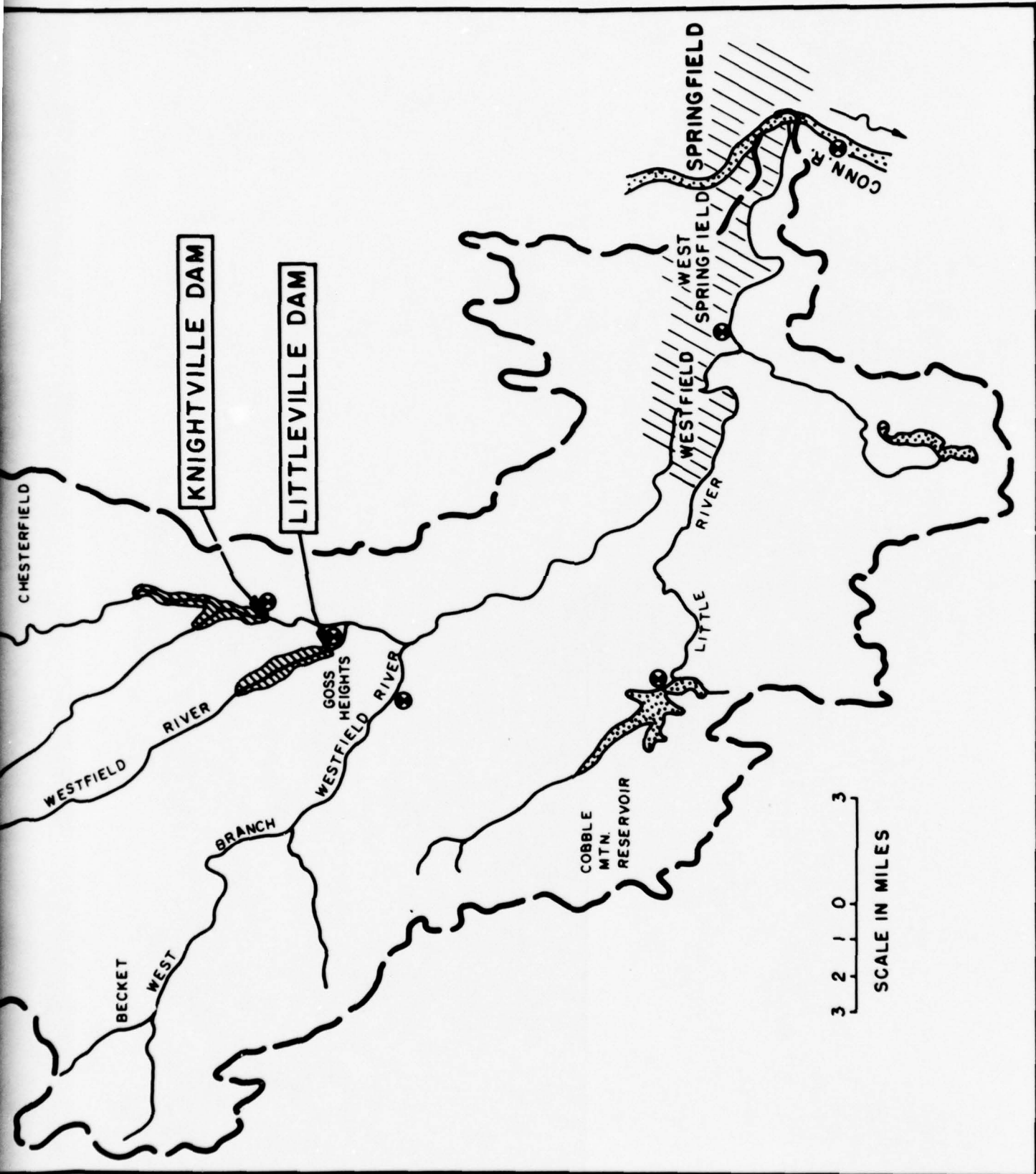

2

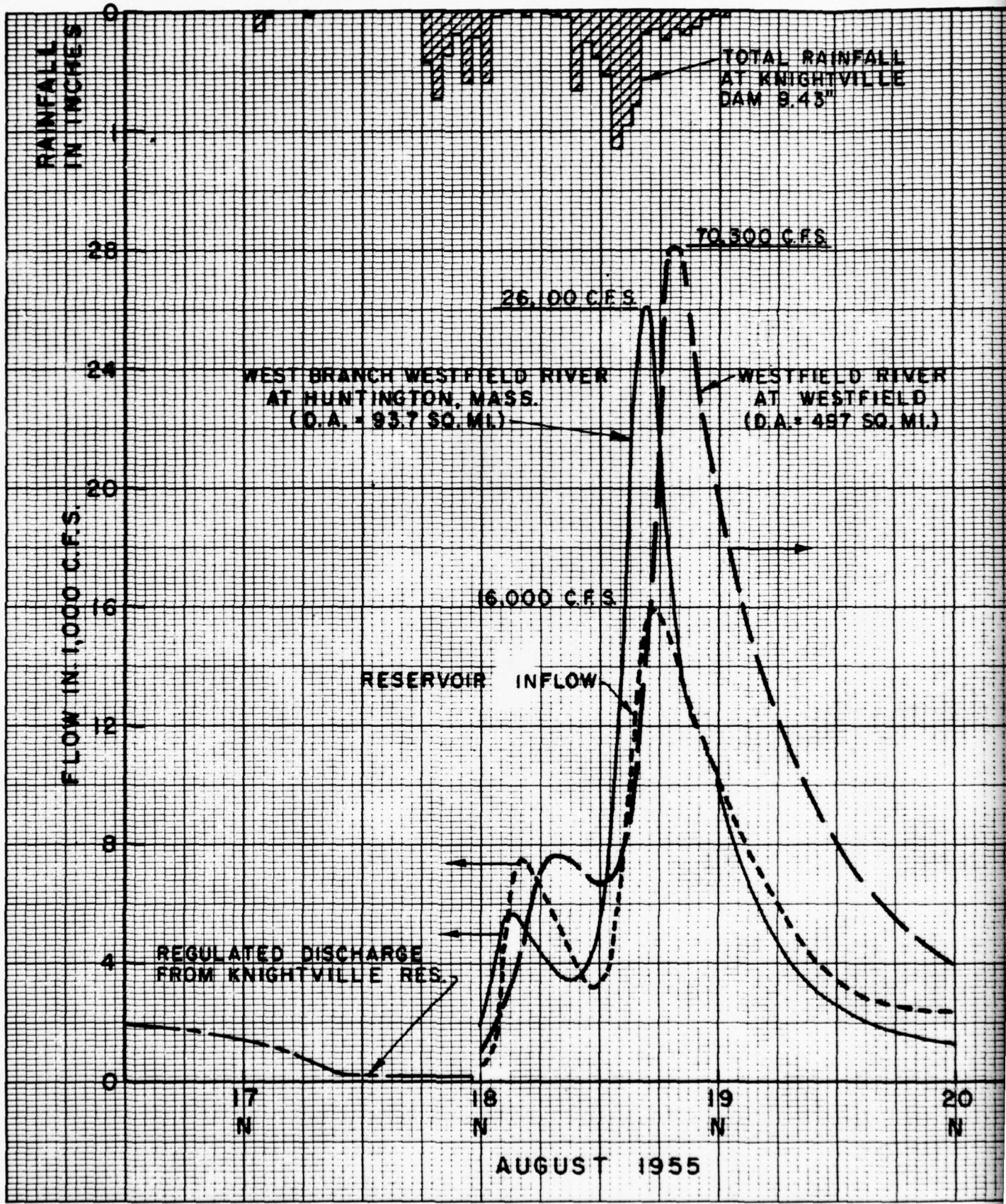

RAINFALL
KNIGHTVILLE
2.43"

C.F.S.

WESTFIELD RIVER
WESTFIELD
(497 SQ. MI.)

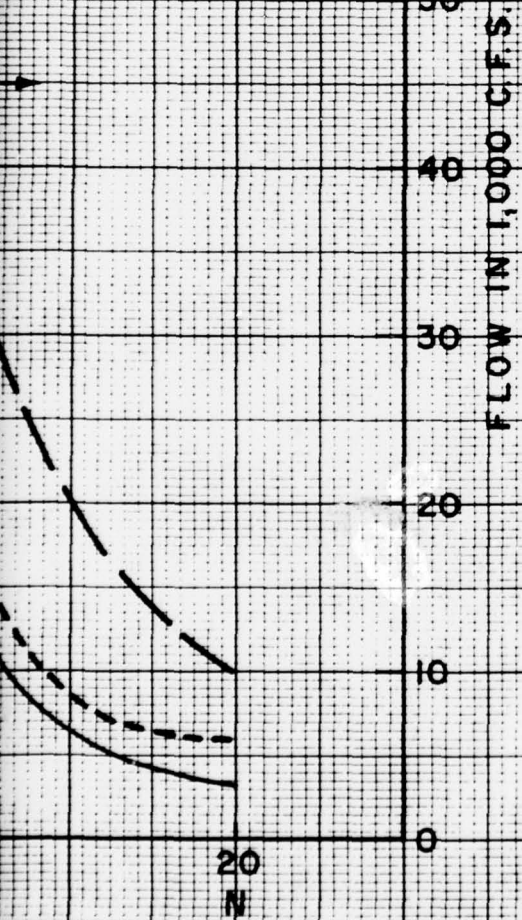

FLOOD OF AUGUST 1955
REGULATION AT
KNIGHTVILLE RESERVOIR
AND WESTFIELD, MASS.

2

of the 18th and morning of the 19th, the gates already were closed. Because of the 3 to 6 hour travel time from Knightville to Westfield, you can understand why we have to regulate almost prematurely in order to provide stage reductions. Therefore, during our initial regulation phase, where we regulate for tributary damage centers, there does not appear to be sufficient time to develop elaborate forecasting techniques.

Although the August 1955 flood developed over the lower third of the Connecticut River, it produced the third largest flood at Springfield, Massachusetts. Plate 3 shows the relative timing of the flood with the inflow at Knightville. During this second phase when we regulate for the main stem, we should have a few hours of lead time before decisions have to be made. It is this phase where we are weakest as far as developing forecasting techniques and simulations of various plans of regulation. For the August flood there was no question that the reservoir remained closed until the peak passed Springfield. However, there are other types of floods which occur in the spring when conditions are not as clear cut.

In the spring of 1969, a record snow cover over all the northern and central watersheds in Vermont, New Hampshire and Massachusetts posed a serious flood threat to the Connecticut River as the runoff period approached. The water content in the snow varied from 150 to 250 percent of normal and water equivalents from 8 inches to 14 inches were quite general. From the last week in March through the month of April, a series of five storm periods, associated with melting snows, resulted in high sustained flows on the Connecticut River. For 24 days, the Connecticut River at Montague City was above the alert stage of 22 feet, equivalent to a flow of 52,000 cfs. This was the first significant operation since completion of 11 new reservoirs in the basin and during this period, record amounts of flood control storage were utilized at the six northern reservoirs, ranging from 53 to 71 percent of capacity.

During this period, an event occurred which reveals one of the problems associated with reservoir regulation in the basin -- the sudden and significant effect of the Deerfield River runoff on Connecticut River discharges. A rapidly moving intense storm spread across southern New England during 22-23 April depositing 2 to 3 inches in western Connecticut and Massachusetts. During the afternoon and early evening hours on 22 April, when it became apparent that heavy rainfall was occurring over southern New England, all reservoirs in the basin were either throttled or shut down. The Connecticut River discharges, which had been flowing at near bankfull capacity as a result of upstream regulation procedures, started to rise quickly and in less than 18 hours rose from 80,000 to 103,000 cfs at Montague City, Massachusetts. As can be seen from the hydrographs on Plate 4, the uncontrolled discharges from the Deerfield River caused most

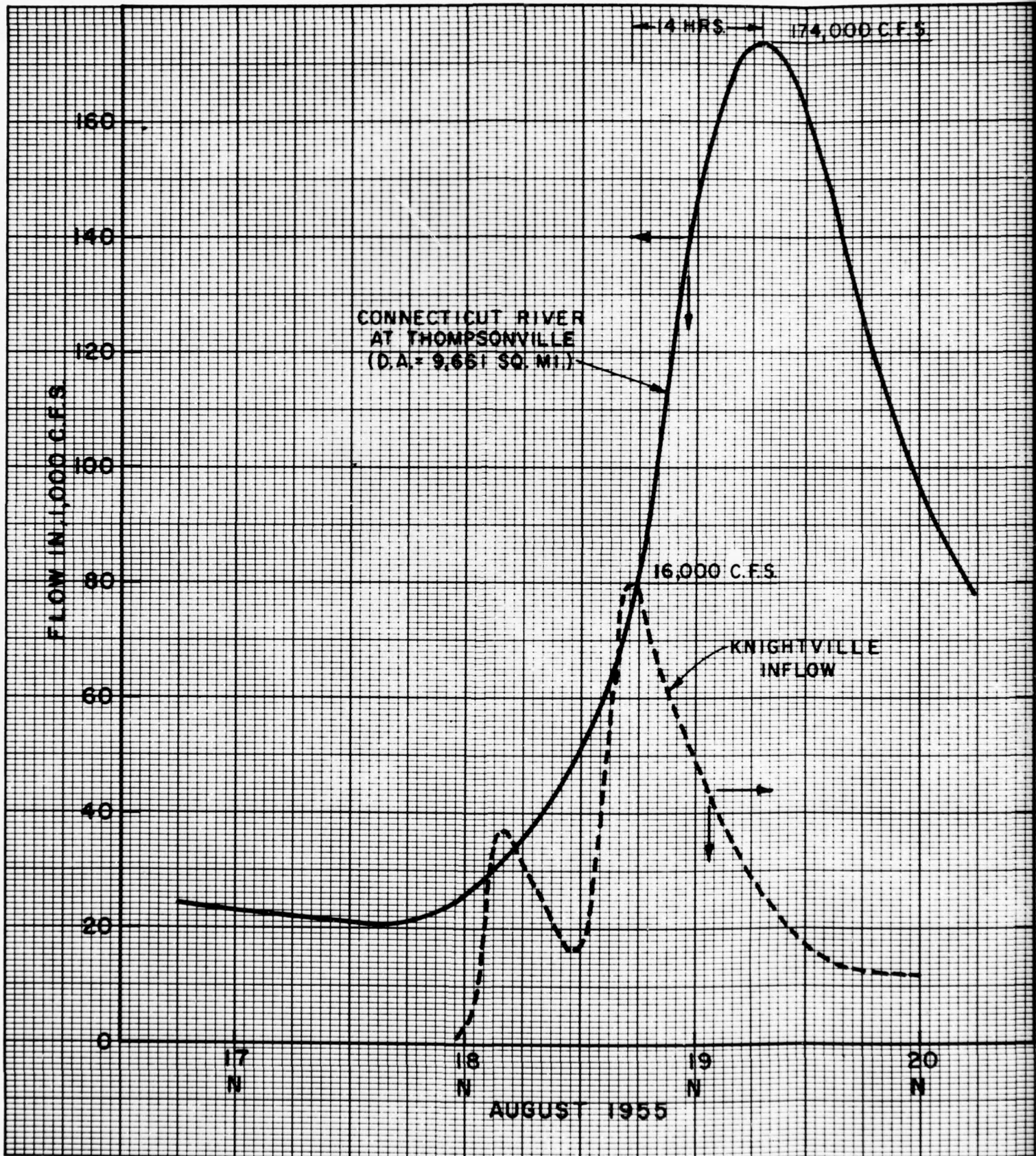

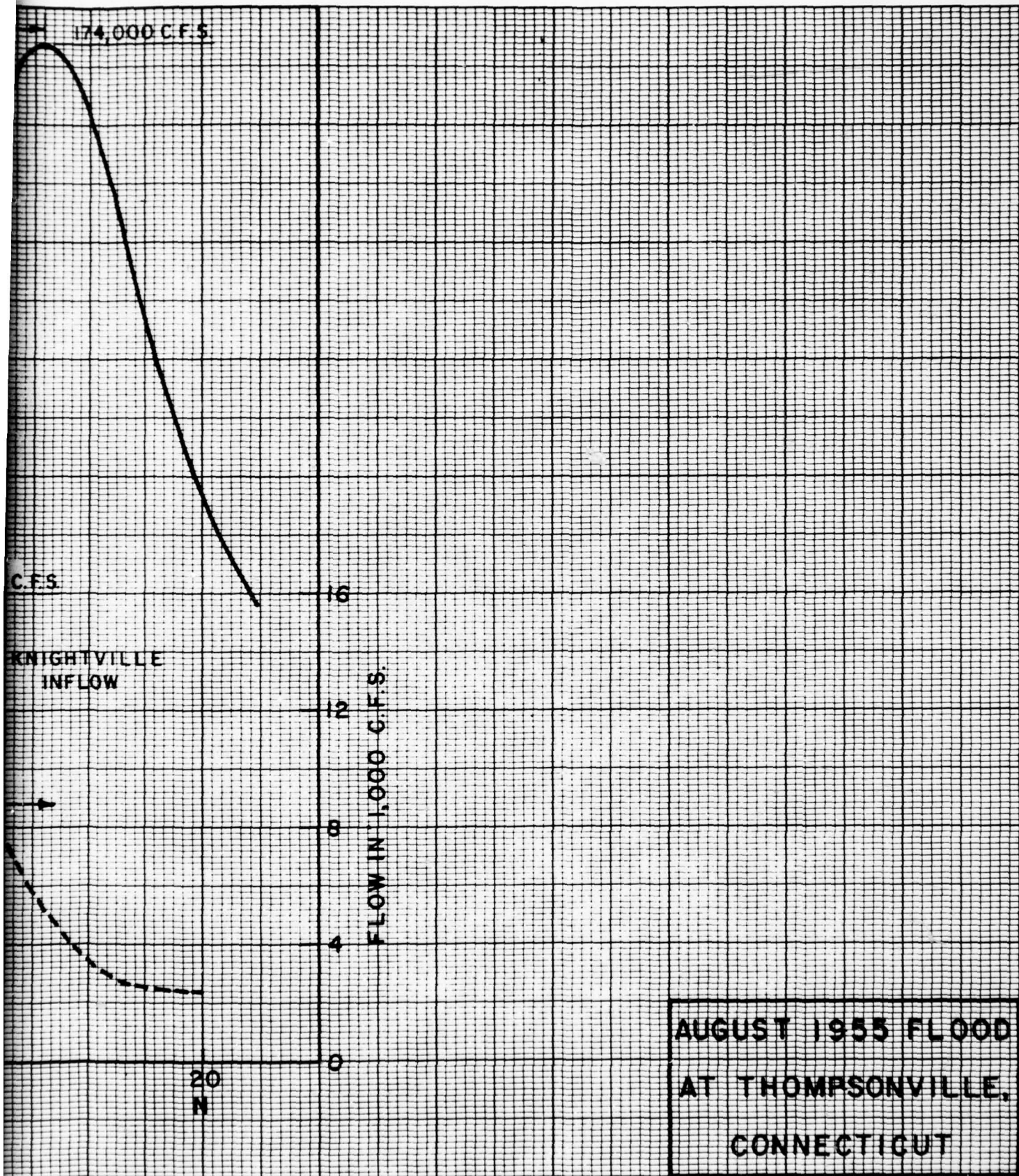

2

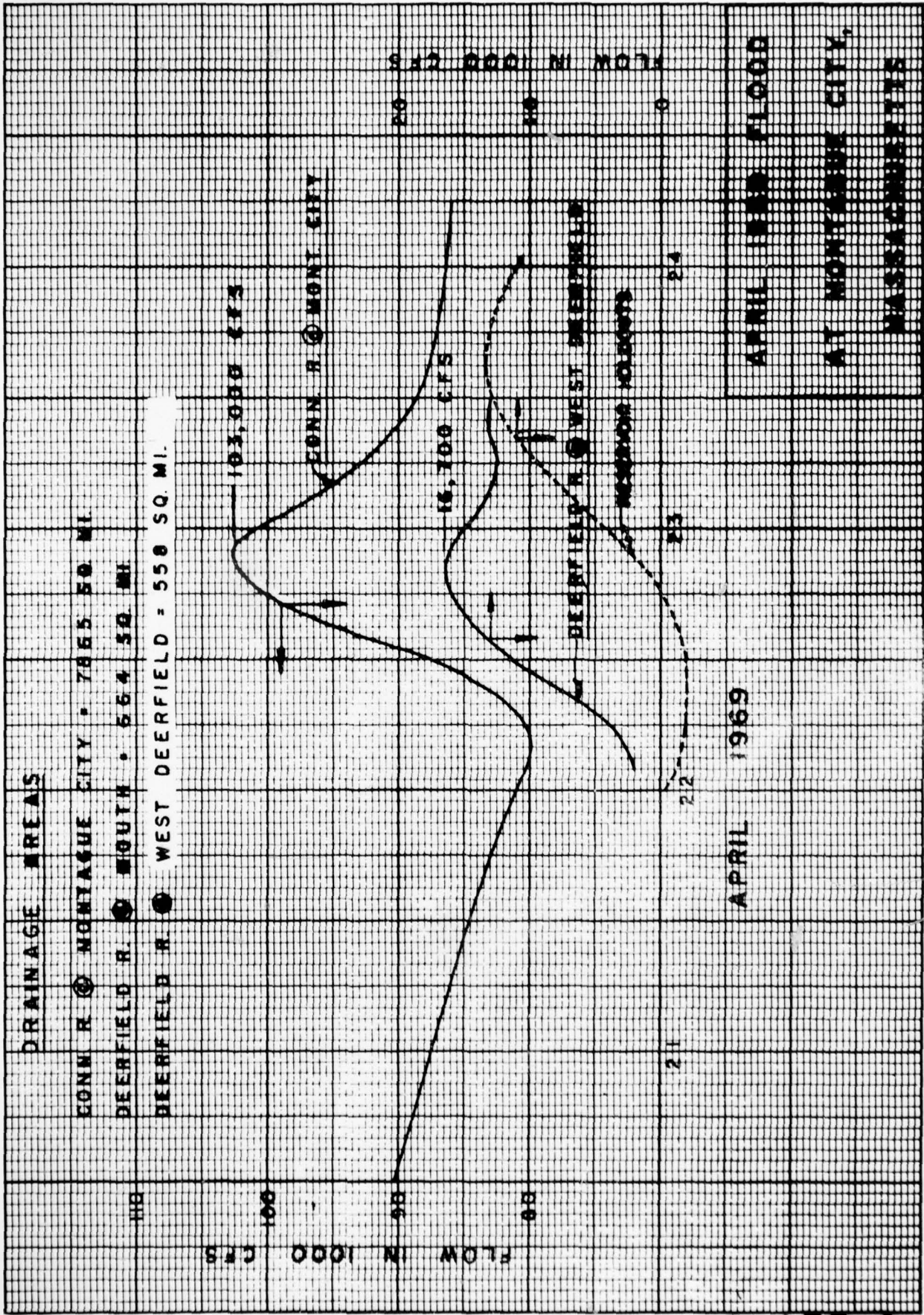

of this rise. Although we closed most of the gates at our dams on the 22nd, their holdouts did not have too much of an effect at Montague City. This brings into account the timing element and you can see that the reservoirs that did a little good were on the West River where travel time to Montague City is not as great as those further north. So this becomes a critical area where the river can rise above flood stage in less than 24 hours and travel time from the reservoirs in most cases is greater than this amount. (See Plate 5).

All major tributaries in Vermont and New Hampshire experienced record volumes of runoff in April; for example, the runoff was 20 percent greater than the previous maximum for that month based on over 50 years of record for the White River at West Hartford. Despite the high volume of runoff, the natural peaks on the Connecticut River are estimated to be in the frequency range of once in 5 years. Table 3 lists the reservoir storage utilized during the spring runoff of 1969. It is evident that during the spring runoff period we need good forecasting techniques and also simulation programs to aid in the regulation of large systems of reservoirs.

Another important consideration during phase two of a major flood is spillway discharge at projects where the government has not acquired fee or easements on properties above spillway crest. Regulation procedures must take into account the adverse effects in the reservoir area if water is stored above spillway crest versus the adverse effects downstream if the water is released through the outlet works.

The third phase of our regulating problem is the emptying of the reservoirs on the recession of the flood peak. This is fairly easy with only a few projects, but in the Connecticut basin our 16 projects pose a problem. We have begun a computer program for emptying the system, trying to maintain an equal amount of storage available at each project. We still have a long way to go before it is finished, but some of the parameters include:

- Reservoir inflow.
- Reservoir outflow.
- Immediate downstream channel capacity.
- Travel time to Connecticut River downstream control points.
- Order of downstream control points for each dam.
- Time at each set of flows.
- Reservoir storage at current time.
- Reservoir storage at spillway crest.
- Flood discharges at all control points.
- Drainage area at all reservoirs and control points.
- Predicted precipitation.

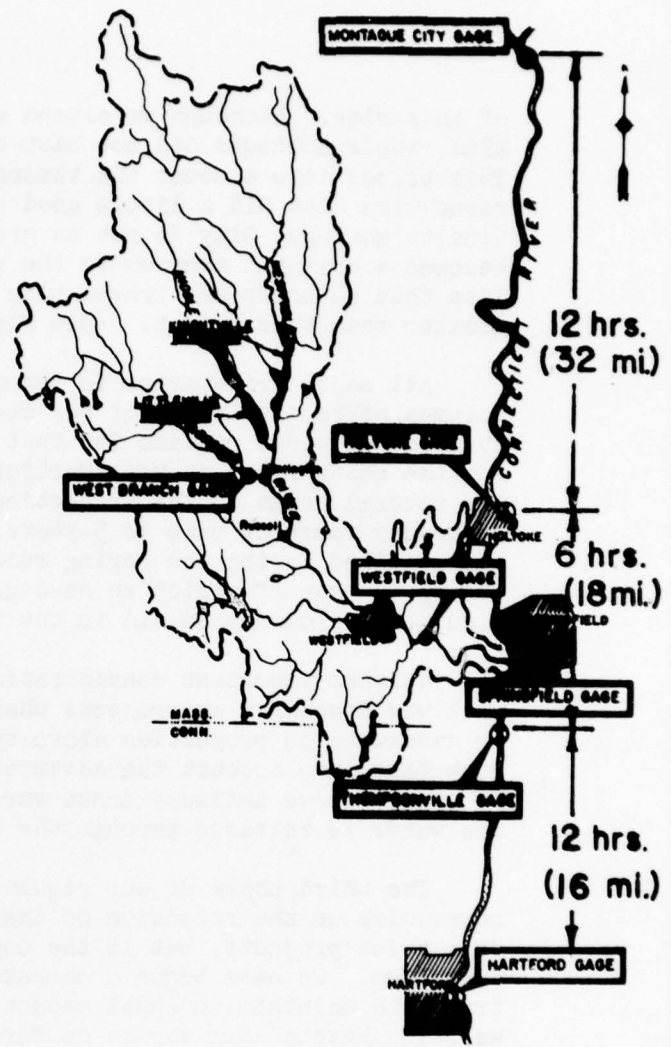
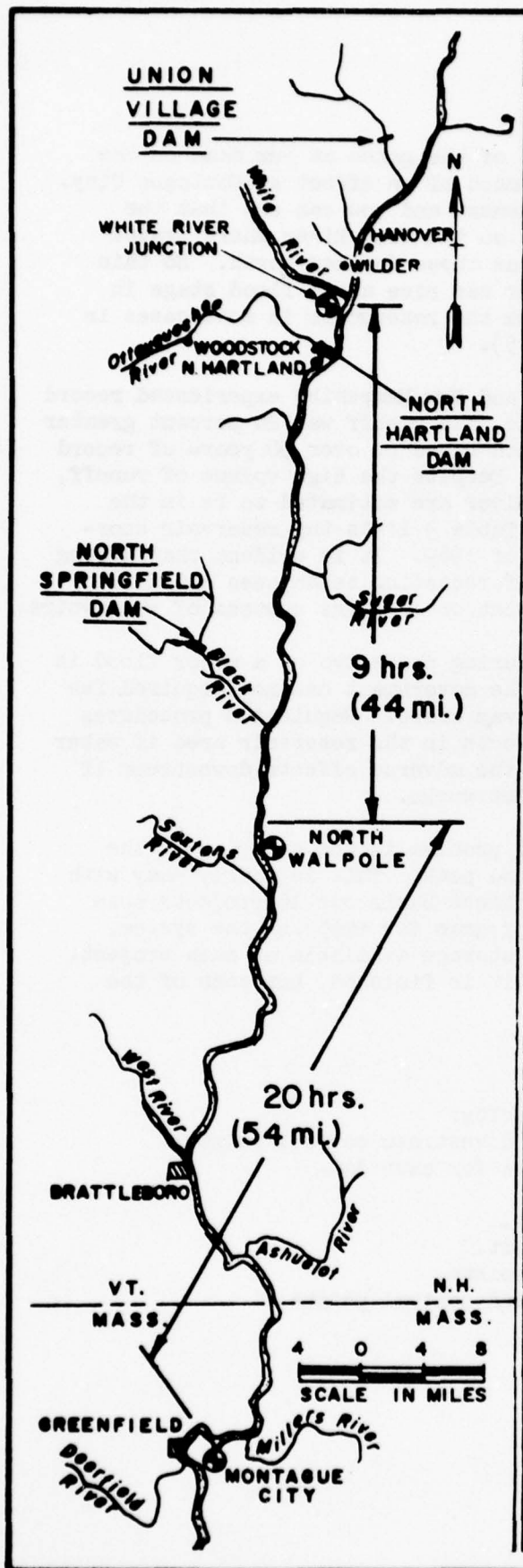

**CONNECTICUT RIVER
TRAVEL TIMES DURING
FLOOD PERIODS**

TABLE 3
1969 SPRING RUNOFF
MAXIMUM FLOOD CONTROL STORAGE UTILIZED

	Maximum Pool		Storage Utilized		% Full
	Stage (ft)	Elev. (ft, msl)	Ac/Ft	Inches	
<u>Connecticut River Basin</u>					
Union Village	114.2	534.2	20,000	3.0	53**
North Hartland	128.2	518.2	44,900	3.8	63**
North Springfield	78.8	530.8	34,000	4.0	68**
Ball Mountain	197.8	1003.3	42,000	4.6	66**
Townshend	80.3	537.3	22,400	4.0	66**
Surry Mountain	55.8	540.8	23,000	4.3	73
Otter Brook	82.6	765.6	12,300	4.9	71**
Birch Hill	22.6	837.6	16,000	1.7	33
Tully	24.2	649.2	5,200	2.0	24
Barre Falls	Insignificant storage utilized			-	
Knightville	89.2	569.2	18,400	2.1	38
Littleville	-	540.7	7,550	2.7	33**
Colebrook River	-	708.7	48,000	7.6	-**
<u>Merrimack River Basin</u>					
Franklin Falls	-	349.1	56,000	1.1	35
Blackwater	-	561.6	34,800	5.1	72**
Hopkinton	-	405.0)	69,600*	2.7	44**
Everett	-	397.1)			
MacDowell	-	930.0	5,300	2.3	42

* Occurred with Hopkinton elevation at 403.1
and Everett elevation at 396.4

** New record

The River Forecast Center (RFC) of the National Weather Service forecasts flood stages for the rivers in New England. They use unit hydrographs and have correlated storm rainfall and runoff with average weekly temperatures. From this analysis, the RFC expanded its forecasts to include 12 hour rainfall required to bring certain rivers up to flood stage. This forecast is issued weekly throughout the year and is a useful guide. Because the RFC predictions are based on rainfall that already has occurred, they are not too helpful on the tributaries that peak at the end of the heavy precipitation.

We have come a long way, completing a real time data acquisition system. Mr. Mirick will enumerate the programs we have completed to help in making reservoir regulation decisions. I feel we can and will obtain excellent results for the minor and moderate floods, but we do not have procedures worked out for major floods with high volumes when spillway discharge occurs. Since our reservoir system is fairly new, we have not gained operating experience for the entire system during a major flood. It is in this area that we are looking for help to develop the programs that can be run on our computer in the time frame we have available to aid in our reservoir regulation decisions.

COMPUTER PROGRAMS REQUIRED FOR REGULATING
COMPLEX RESERVOIR SYSTEMS FOR FLOOD CONTROL

Discussion

Question, Mr. Matthews: (1) Do you have regulation guides? (2) Are spillways gated or ungated? (3) Do you have resident operators?

Reply, Mr. Cooper: (1) Yes. (2) Most are gated. (3) Yes - they are under the Operations Division ordinarily and under the RCC during critical periods.

Question, Mr. Sharp: What is the areal distribution of automated hydrometeorological stations with respect to damsites.

Reply, Mr. Cooper: Of the 33 river stations, three are situated upstream of NED reservoirs and the remainder are on tributaries or along the main rivers.

THE POWER OF A GENERAL-STORAGE DATA ARRAY

By

William A. Thomas¹

A general storage data array is a single dimensioned array which treats computer memory as if it were a large block of space and allocates each variable array to this space by uniquely defining, for both the computer and the programmer, the location of its base element. For example, the general purpose data storage array, U(5000), could contain an array of values of elevation vs. storage capacity, a discharge rating table for spillway, an outlet works discharge rating table and two rating tables for auxiliary spillways. These would appear in the FORTRAN as U(LES), U(LSR), U(LOR), U(LAR1), and U(LAR2). Figure 1 illustrates how these variables are stored.

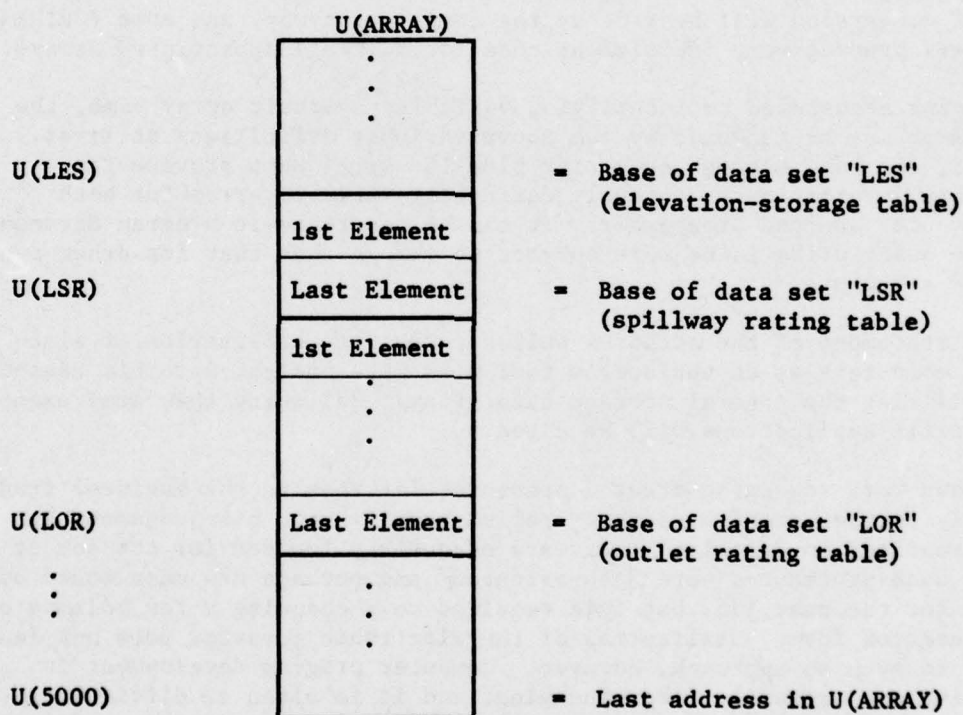

Figure 1. Storing Variables in the U (ARRAY)

¹Research Hydraulic Engineer, U. S. Army Corps of Engineers, The Hydrologic Engineering Center, 609 Second Street, Davis, California

The base element for the elevation-capacity table might be 1 or it might be some other element in the U(ARRAY). In either case U(LES) always locates the data for the elevation-capacity table by pointing to its base element. The base element for the next variable array to be stored in U can be calculated from LES and the number of values in the elevation-capacity table. The procedure is repeated until all variable arrays are stored.

The single-dimensioned array is utilized because it is the "lowest common denominator" to which all arrays can be conveniently reduced. If the input data needs to be two-dimensional or multidimensional or parametric sets of values, it can be so. However, all are converted to a single-dimensioned array upon input, and the variables are used as single-dimensioned variables during the entire program. For example, the elevation-capacity table above contains two columns of thirteen values each and would normally be accessed by ELSTO(I,J). However, in the U(ARRAY) this table would be accessed by $U(LES + K*(J - 1) + I)$ where K is 13, in this case, and I and J are analogous to rows and columns, respectively. This does not reflect additional computations. This type of conversion will be made by the compiler anyway, and some FORTRAN compilers produce very inefficient code for multiple subscripted arrays.

Being accustomed to identifying variables by their array name, the programmer may be confused by the above variable definitions at first. However, the base element subscript plus the array name provide the necessary information to uniquely define any variable array for both the computer and the programmer. It can be described in program documents and the description is no more subject to change than that for other types of data structure.

A statement of the author's philosophy of the utilization of electronic computers as an engineer's tool will give insight into his reason for utilizing the general-storage data array. Following this some examples of specific applications will be cited.

When work scheduled created pressures for results the engineer traditionally devised procedures which relied heavily upon his judgement but which resulted in decisions that were adequately founded for the job at hand. Such procedures were "job-oriented" and perhaps new ones would be needed for the next job, but this required only changing a few columns on a computation form. Utilization of the electronic computer does not lend itself to such an approach, however. Computer program development is expensive and extremely time consuming, and it is often as difficult to change a completed program as it is to develop one from scratch. Put in the situation of having the use of a "job-oriented" program for general application, the engineer has the pressure, not only of completing studies, but also of approximating, of simplifying and of transforming portions of

studies to conform to program stipulations. He must then interpret the significance of the simplifications on the results and draw conclusions. It is not unusual for this effort to so completely dominate the entire study that the engineer feels he is being used by the machine. As a result many engineers find reasons for avoiding the computer when at all possible.

The engineer considers that neither developing nor using a computer program is an end in itself; it is merely a means to an end. When programs which will serve his needs are available, the engineer will use them in accomplishing his jobs. The unique feature of these programs will be that they are user-oriented.

A systematic procedure for one to follow in moving from the initial conception to the final product, a user-oriented program for general application by the practicing engineer, has not been advanced. This paper does not attempt such. However, it is the author's opinion that the most important phase of program development is the initial planning phase. Here an overall plan is established for the completed program. Only portions of this plan may be implemented initially, but having an overall objective provides guidance for developing program logic, identifying functional parts and designing an appropriate data structure for the present as well as for future expansion. Very fundamental to this concept is the fact that future expansion is expected and a flexible data structure will be required to accommodate it.

The type of program which the author desires, as a practicing engineer, is one which gives the user maximum control over computers. Its functions should be developed as separate algorithms, and most attractive are algorithms which can stand alone so the "module" concept of program development can be utilized. This would permit the engineer to utilize subprograms, previously developed, for forming new programs. One great advantage of such "modules" is that debugging aids and special error recovery logic can be built into the basic package. Trace and debugging aids are very important to user-oriented programs. These can be incorporated into any program, but programming time does not usually permit it for short life programs. The type of modules that are particularly useful in the water resources area are table search and interpolation algorithms, input algorithms for data arrays, the calculation of geometric properties, optimization algorithms, convergence criteria algorithms for solutions requiring successive approximation, etc. Another aspect of a user-oriented program is that it can be scaled up or down when necessary to fit problem and machine size. When modification is required to accommodate special features of a job, a user-oriented program will permit the modification to be accomplished with a minimum amount of programming effort. Finally, the input data format must be convenient to use, the amount of required data kept to a minimum, and the amount of optional

data kept to a maximum. Extensive program logic is required to develop this type of input data flexibility, and it should be developed as an algorithm and used for as many input variables as possible in as many different programs as possible.

Data handling and related logic are the major part of any computer program, but it is especially important to a user-oriented program. The general-storage data array offers many desirable features for accomplishing the type of programs the author is proposing. It permits maximum flexibility in the utilization of available computer memory without reprogramming by permitting the user to allocate memory space among his variables with input data on a job to job basis. Linkage between program subroutines and between program segments is easily established or changed because the number of variables is reduced. Programs may be developed around the "module" concept with assurance that the individual data structures will be compatible with each other, and programs may be scaled up or down with ease by just changing the dimension of the U(ARRAY). The FORTRAN coding for using such a data structure lends itself to future expansion because data locations are specified as relative to some variable base element rather than the absolute location of standard type data structure. Debugging printout and program trace printout can be obtained easily by printing the entire array if necessary. The following applications of this concept have proved it to be very useful and suggest that much wider applications are possible.

In the first application, a period of record, interior drainage study was made to produce stage-frequency curves for the sump and energy requirements for a pump station for pre- and then for post-project conditions on the Arkansas River. The routing had to account for both gravity flow and pumping.

The bulk of data was the result of storing, in table form, the information shown in figure 2. The storage vs. elevation data, figure 2a, gravity flow through the culvert, figure 2b, and pump characteristics data, figure 2c, all required table look-up procedures. The rating table for the culvert contained river stage as a parameter and the characteristic curves for the pump required shifting the dependent and independent variables back and forth from head and discharge to discharge and energy as calculations proceeded. Memory size and programming time did not permit utilizing different table look-up algorithms for each situation; therefore, all variables were stored in the U(ARRAY) and a single table look-up algorithm was developed.

Linkage between the main program and the table search subroutine was accomplished by putting the U(ARRAY) in common and transferring the proper base element locator and independent-dependent variables at the call statement as follows:

```

Main Program:      COMMON      U(1000)

                   CALL      TBS(IX, IY, NX, NP, LBE, X, Y, P, F)

Subroutine:       SUBROUTINE  TBS(IX, IY, NX, NP, LBE, X, Y, P, F)

                   COMMON      U(1000)

```

where IX = column number of independent variable in multi-column array
 IY = column number of dependent variable
 NX = number of (X,Y) points in table
 NP = number of parametric curves (sets of (X,Y) points)
 LBE = location of base element in U-array
 X = value of independent variable
 Y = value of dependent variable
 P = value of parameter
 F = flag information

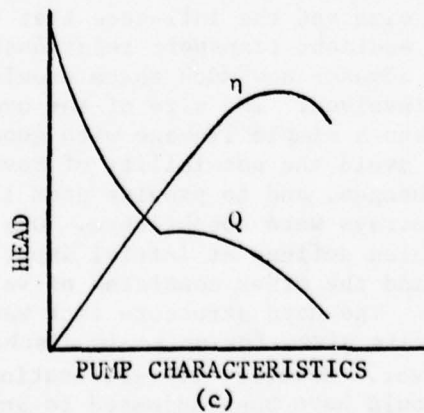
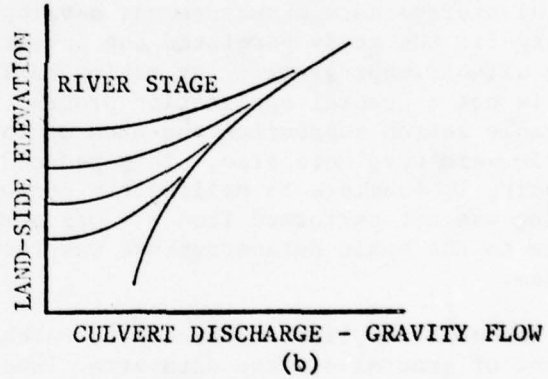
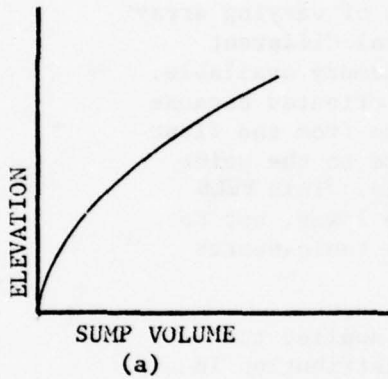

Figure 2. Basic Data for Interior Drainage Study

The river stage was furnished to the table search subroutine for that table requiring it as a parameter, and the column numbers of the dependent and independent variable to be considered in the multi-column table of pump characteristics was furnished also. The procedure worked nicely. The table search subroutine was developed into a "module" that has been used in several other applications with no reprogramming except to change the size of the U(ARRAY) to fit requirements of the calling program. An additional discharge rating curve was later added to simulate another outlet, and it only required establishing do loops whose limits were defined by the number of outlets desired. The new discharge rating curve did not have to be parametric. In fact, with the do loops defined by the number of outlets with input data, any number could be simulated with no additional programming.

A routing situation involving two reservoirs connected by a canal required special study for design memorandum purposes. The outlet structure was located in one reservoir and the emergency spillway in the other. Because of the large number of variables involved and the possibility of modifying the general arrangement of facilities during design studies, a general-storage data structure was developed. The freedom of varying array size to fit the study permitted the investigation of several different plans without reprogramming by making maximum use of the memory available. This is not a general application program, but it is user-oriented because the table search subroutine and much of the input algorithm from the first example were used here also. This reduced programming time to the point of making it feasible to utilize the computer in this study. This PULS routing was not performed from $S + Q/2$ curves like example 1 was, but no change to the basic data structure was required to use the table search routine.

The most complicated problem to which the author has applied the concept of general-storage data array involves sediment distribution in a reservoir. Because of the complex relationships between hydraulic parameters, sediment load and grain size and the influence that the composition of the bed has upon the sediment transport relationships, it was not possible to determine in advance how much space should be allocated to each of the variables involved. The size of the overall program necessitated segmentation, and a simple linkage with good debugging features was desired. To avoid the possibility of having to reprogram to accommodate minor changes, and to provide good linkage for segmentation, two general data arrays were established. One consisted primarily of coefficients and variables defined at initial input and retained throughout the entire run and the other consisted of values that were changed each computation cycle. The data structure that was developed permitted the analysis of up to 8 grain sizes for up to 10 discharges in a set and through 7 reaches of the river. However, if verification of the model had dictated, these numbers could have been adjusted to any other combination as long as their sum did not exceed the total memory

space acquired by the U(ARRAY). The resulting program was adapted to the job, rather than requiring the study be modified to fit the rigid requirements of the machine.

The flexibility of this design was of great value later when a completely different sediment transport relationship was incorporated into the program. The original transport relationship required 3 variables; the new one required 6 variables. The transition was made by changing the base element locations to account for the proper number of variables. No changes were required to the statements actually using the variables, because base element names did not change. Statements were added to perform linkage with the new algorithm.

In Summary . . .

In the field of hydraulic engineering, studies deal in both the time and space domains. Functions are represented as arrays of discrete values and integration and differentiation are accomplished by numerical techniques. The number of gage locations, controls, tributaries and damage centers change from project to project and the amount of detail required changes from study to study. A large number of variables are involved and their importance, relative to each other, changes from job to job. Data storage and manipulation is a major part of any computer program.

Computer applications are still in the early stages of development and changes to existing programs are constantly in demand. The only way to make progress is to carefully design programs according to a comprehensive plan and provide for future expansion. Avoid reprogramming where possible and minimize the effort for accomplishing unique studies by designing a simple data structure that is flexible to changes in the number of variables as well as the amount of data that can be used to define a variable. The general-storage data structure offers not only a flexible data structure but also causes a more flexible type of program logic to result by inviting iterative computation logic which does depend upon knowing that the absolute location of data is in element 1 of an array. Therefore, changes and additions can be accomplished with much less programming than is required for the more rigidly specified data structure. The user can translate the program from one machine to another, scale it up or down to accomplish most efficient use of memory space, develop subroutines as "modules" with assurance that their data structures will be compatible and assign the length of variable arrays at execution time with no special requirements to input data. The results are programs which can be applied to jobs with the sensation that the machine is a tool of the user rather than the user a tool of the machine.

THE POWER OF A GENERAL-STORAGE DATA ARRAY

Discussion

Comment, Mr. Beard: The technique of combining data in a single-dimensioned array can be applied to computed quantities, as well as to input data. The HEC-1 package has a good example of this, where hydrographs for possibly 5 locations, 4 plans of development, and 9 flood sizes can be carried in storage. With 150 ordinates per hydrograph, this takes 27,000 memory locations. This information was formerly stored in a triple-dimension array, but is now stored in a single-dimension array, allowing great flexibility in combinations of numbers of locations, floods, plans and ordinates. Of course, it is especially important to have a program check for exceeding dimension capacity, because the user can easily exceed the capacity inadvertently.

Reply, Mr. W. Thomas: It was not the author's intent to limit use of the general-storage data array to input data. The same variable names used to input data are also used in data manipulation, computations, linkage between various subroutines and linkage with secondary storage. Values in these storage locations may be initialized by input data but changed many times during the execution of the program.

Question, Mr. Mirick: Why confine this data array concept only to core storage area, instead of disk file area?

Reply, Mr. W. Thomas: It was not intended to imply that this data structure was limited to the computer memory. It is appropriate as a basic data structure in both internal and external storage.

COMPUTER PROGRAMS USED TO COLLECT, STORE
AND ANALYZE DATA RECEIVED FROM THE NEW
ENGLAND DIVISION AUTOMATIC HYDROLOGIC
RADIO REPORTING SYSTEM

by

Robert Mirick¹

INTRODUCTION

1. PURPOSE

There have been discussions at this seminar on the advantages and disadvantages of closer contact between the programmer and the computer. The program I will describe is designed for reservoir regulation personnel to operate an IBM 1130 computer to interrogate, tabulate and plot hydrologic data during the progress of a flood.

2. DESCRIPTION OF SYSTEM

The New England Division improved the speed of receiving, analyzing, and computing the large volume of river gage, tide gage and reservoir data so that optimum regulation procedures and control can be achieved at all times. With the aid of an Automatic Radio Interrogation System, combined with a computer and plotter, this has become a reality. The reporting system for relaying hydrologic and meteorologic information into a 16K, 1130 IBM computer was officially dedicated on January 5, 1970. The system was designed and built by Motorola, Inc., under the auspices of the New England Division Corps of Engineers, for the Reservoir Control Center (RCC) in Waltham, Massachusetts. It contains four relay stations, twelve repeater stations, forty-one hydrologic data reporting stations, and five remote teletype receiving stations.

In order to interrogate these stations, an identifying signal from the Motorola interface data control unit is initiated by an 1130 computer program for each of forty-one hydrologic stations. Each remote station then transmits back one to four parameters of information. The two coastal stations report tidal stage, barometric pressure, wind velocity and wind direction, and the remaining thirty-nine stations transmit river stage and/or precipitation. Four of these stations transmit rainfall and river stage and one transmits rainfall only. Since the path of transmission by necessity is line of sight, data from some stations are transmitted through a repeater station and then through two relay stations before arriving at Waltham, thence through an interface to the

¹Reservoir Control Center, New England Division

computer files and printer. The original signal that leaves RCC is modulated and demodulated, in some cases nine different times after it leaves the computer, until it gets to the remote data site. Total time elapse per station interrogation and return is about three seconds unless no answer is received, then three more attempts are made before proceeding to the next station in the program sequence. In addition to the stations described above, individual basin data and computed information can be sent out to five separate remote teletype receiving stations. These teletype stations are also in the programming sequence controlled by the computer so that pertinent alarms, as well as basic and computed data, can be automatically sent to the teletype stations day and night.

The Reservoir Control Center can also send typed messages to any of the teletype stations if desired. The damtenders, however, have only two options at their teletype stations: (1) They can communicate by voice through the system to the computer room at Waltham. Voice communication is in fact possible from any radio gaging station to the Motorola data control unit at Waltham. (2) They also can interrogate a limited number of stations for basic data only.

INTERROGATION PROGRAMS

3. PROGRAMS SUPPLIED BY MOTOROLA

a. General. The original software package and programming for the 1130 computer to control the interrogation system was supplied by SYS Associates, Inc., Fort Lee, New Jersey, through Motorola, Inc. This consisted of a software real time scheduling monitor, an interrogation program and a teletype sending program.

b. Monitoring Program. Real time monitoring and control of the interface was accomplished by the mainline program.

c. Interrogation Program. Other interrogation options and controls were initiated by subroutines.

(1) Options. The original options supplied were:

- (a) Enter time and day of year.
- (b) Print out time and day of year.
- (c) Interrogate any single station by entering its station on the keyboard.
- (d) Interrogate all stations in a programmed sequence.
- (e) Enter times for automatic interrogations.

(f) Automatically interrogate all stations at the times entered.

(g) Send a single teletype message.

(2) Subprograms. Other subprograms not directly controlled by the subroutine were:

(a) Interrogation Printout Subroutine. This routine printed out the station number, time, river stage and/or rainfall for 39 stations and tidal stage, barometric pressure, wind velocity and direction for the two coastal stations. A battery "charge alarm" and "no report" messages were printed when applicable.

(b) Time Delay. Interrogation and teletype signals required that the computer be delayed in carrying out its next programmed instruction until the mechanical and/or electrical, and radio transmissions were completed. These were accomplished by a time delay routine in assembly language called from a fortran subprogram.

(c) Time. A time routine maintained a record of day of year, hours and minutes and the variables were in common through all subroutines that used the common area.

(d) Interrogation Time Looping Subroutine. This subprogram continually refreshed itself by calling a routine which recalled the looping subroutine back again. This process continued until time of day coincided with any one of the interrogation times entered, or a console switch was thrown which would return control to the keyboard options.

d. Teletype Program. A third package supplied was the teletype routines called from the control subprogram. Initially, this sent one preset test message to any of the five receiving stations.

4. NEW ENGLAND DIVISION PROGRAMS

a. Files. At the present time, the interrogation programs have been expanded to meet the needs of the Reservoir Control Center. Six existing files used for plotting reservoir data on a Calcomp 502 plotting table from card input have been expanded to include the 41 stations of the Automatic Interrogation System. These files are as follows:

(1) File 1 contains the station number, station name, drainage area, alert and flood stage, stage-discharge and stage-capacity tables for reservoirs for a selected stage increment for every station. Interpolation routines compute the discharge or capacity from these tables.

(2) File 2 contains station number and plotting scales for stage, discharge and time.

(3) File 3 contains plot sheet number and station arrangement on one to ten sheets.

(4) Files 4 and 5 contain the station number and last file read and last file plotted, respectively.

(5) File 6 contains the station number and from 1-200 back readings of each station. The readings include time, stage, discharge, precipitation (or outflow and inflow) and an alarm message. One of five alarm messages or a blank is compacted with the precipitation parameter on file, so that these messages can be printed or sent out on the teletype at a later time.

(6) A seventh file was set up on a separate file disk for long term storage of stage data. The stage and time only are stored in two words. This tight compaction allows about 1/4 million readings or four years of data on one disk. If a more permanent storage is required in cards, a "dump" operation from disk file to card output in binary can be performed.

b. Present Programs. The present interrogation program contains most of the original options, but most of these options now have sub-options. To start the program, a basic operating data card is read after execution. This card contains all interrogation times and other data needed to operate for normal conditions. If different interrogation times or controls are needed, the changes can be made by this card or by keyboard options. Program options are as follows:

(1) A single station scan can be printed and put on or off files.

(2) An all station scan can be printed and put on file.

(3) Enter day of year and time of day. This is the only option that has to be entered by keyboard with every loading of the program.

(4) Enter 8 interrogation times, zone control, and rainfall tolerance. The 8 interrogation times are in such a manner that if the first four are tested against time only then the system will interrogate all stations every 6 hours. If all 8 times are tested, then 3 hour readings can be obtained. Zone control permits intermediate interrogations of the two coastal stations or two of the larger basins on any time increment, in minutes, provided it will divide evenly into any one of the all station scan intervals. Rainfall tolerance, the last entry, will cause all data to be sent out to the teletypes. If the tolerance is exceeded, its value will be reduced by ten percent.

(5) Automatic all station scan at four or eight interrogation times per day will be made with or without intermediate scans of the two coastal stations or two river basins. At the completion of an automatic all station scan, data from one or two key index stations will be sent to each of the five teletype stations. Both calculated and observed data are sent from the last reading just put on file. If no reading was received from that station, a no report message is sent along with the previous reading that was received. Any alarm reading will cause all stations to be sent instead of the single index station. These alarms are as follows:

(a) "FSTG" - The reading of stage is at or above flood stage.

(b) "WARN" - The reading of stage is between the first alert and flood stage.

(c) "RAIN" - If the difference in rainfall total at any of the five precipitation stations exceeds the rainfall tolerance, the tolerance will be reduced by one-tenth, or by two-tenths the tolerance if twice the tolerance is exceeded. Whenever the tolerance is cut below .22 inch, 3-hour interrogations will be initiated. A warning stage will cut the tolerance to .24 inch of rain. Any further rain alarm will set the system to interrogate every three hours instead of six hours. A flood stage will also set the system for three hour interrogations and cut the rainfall tolerance to under one-quarter inch.

(6) The first line of every automatic teletype contains identifying asterisks followed by the current information on:

(a) The last station to cause an alarm on the system;
"0" if none.

(b) Time in day of year, hour and minute.

(c) Day of month.

(d) Three or six hour intervals for all station scans.

(e) Rainfall tolerance in hundredths of an inch.

(7) A utility program for the files was developed out of a listing program. Many different options of listing back data from file and resetting overlapping and correcting any files were developed. Any number of back readings (from 1-200) for a single or all stations in a basin can be listed. Even a simple listing of data cards was found to be a useful subprogram to add to this subroutine.

Additional internal routines have been added and some existing ones altered, as follows:

(a) The interrogation printout subroutine includes the checks for flood and warning stages, rainfall, nonvalid and no reports. It prints out the current file number, station name, time, stage, discharge, discharge per square mile and precipitation if included. The routine also keeps track of the last file number for each station and enters the data on the next file.

(b) The interrogation time looping subroutine not only selects the correct time for interrogations, but controls the order of stations reporting.

(c) Zone control determines the correct time to interrogate intermediate coastal or dual basin scans such that the all station scan will go off at the prescribed times, regardless of the time when the program was initiated.

(d) Interpolation and extrapolation routines calculate discharge or reservoir storage from tables on file.

(e) A data transfer routine will move interrogated stage data and the computed discharge for six of the uncontrolled dams to a different file number and location so that reservoir capacity tables may be used for computing inflow and storage available. These latter file station numbers should be used when setting up the reservoir data plotting program. This transfer is performed by a special subroutine that is now called once daily after 7 a.m. to keep these files updated. The rating table that is used to compute the outflow for these uncontrolled dams is interpolated between table values on a straight line basis except for the first increment which interpolates using the weir formula. This gives closer results for low flow readings, especially over a weir or small spillway.

(f) A calendar routine will print out the day and month when given the day of the year.

The teletype subroutines are separate but can be entered by the last option. They can send typed messages from the keyboard or from the card, and the routines can be used to send any number of back readings on file similar to the listing routine in the utility subroutine. These are the routines that are called immediately after the automatic all station scan. Internal subprograms used in the teletype are:

- (a) Convert alpha characters to teletype code.
- (b) Convert real number values to teletype code.
- (c) A control routine switches the sending from one teletype station to the next, sending only the stations that are located within the basin or adjacent to where the teletype is located.
- (d) A looping subroutine sends one character at a time until a single line of teletype is complete.

Since a teletype is not set up in the computer room, a service interrogation program in core image was developed. A short but fast executing program was required so that service testing or a quick stage reading could be made without changing a disk in the console. No files were used and only a repeated single station scan was needed. However, a reading cannot as yet be obtained while another program is in operation.

RESERVOIR DATA AND RIVER GAGE PLOTTING PROGRAM

5. GENERAL

A reservoir data and river gage plotting program was developed prior to the introduction of the interrogation program. Due to inconsistent common areas and limited core storage, they have not been combined. This program will plot the stage and/or discharge hydrograph for any river gage on the interrogation system files. It will also plot the pool stage, outflow and inflow for any of the flood control dams controlled by the New England Division. The input for all stations is from either card input for most of the dams or automatic input following each interrogation.

6. PROGRAM OPTIONS

Similar to the interrogation program, several options are typed on the typewriter.

- a. The first option is for entering input by card or keyboard.
- b. The sheet number, title and layout order for nine box outlines are entered by card or keyboard. Each graph is located in the proper box by entering the station number in proper reading order. Two or three discharge hydrographs can be plotted in the same box on the same scale by entering each additional station by its negative number and a different symbol is automatically plotted with each graph.
- c. Plot the box outline and print all titles for the sheet number entered above.

d. Read the axis data for all stations and place on a file the starting unit and units per inch for stage, discharge, and time. A zero units per inch causes a bypass to the next scale or station in the scale layout of the graphs.

e. Plot all axis data for each box outline on the sheet.

f. Enter reservoir data on card or keyboard, line at a time, reading station number, day, time, stage and discharge.

g. Plot all reservoir and gage data that will fit within the confines of the box outline for each reservoir or gaging station and in accordance with the given scales. Any plot point that would fall outside the box outline is omitted. This process assures that only the range of dates selected will be plotted as well as screening outside non-valid data.

h. Plot all new data from the previous plotted data. This option saves the time of plotting each location from the beginning each time a new set of data is entered.

i. This option is used for changing the time scale only, for all the stations. This allows all the vertical scales and titles to be plotted or reproduced on sheets to be ready in the event of a rapidly developing flood. Only the time scale has to be plotted after all station time scales have been set for the starting time and days per inch. The time required to plot all full sheets with titles and scales could run 3/4 hour. A sheet that is already layed out should not take more than ten minutes to plot time scales and hydrographs.

j. This option is used for changing the sheet on the plotting table and relocating the pen origin.

k. The last option calls in the same utility program used in the interrogation program using the same suboptions for listing or altering files.

SUMMARY

7. GENERAL

It is possible to expand the interrogation system to 99 stations with the available storage and existing hardware. Meanwhile, it may be necessary to economize on storage if new subroutines are added. To date, all but 286 words of the 16 K of core storage are utilized by the present main line program and subroutines.

Although it would be desirable to combine as many programs as possible with real time features of the interrogation program, core storage area is a limiting factor. We are investigating the possibility of multiprogramming capabilities for the IBM 1130. In fact, IBM is preparing a package to go with their new System 7 computer which will be available in the fall of 1971.

AUTOMATIC HYDROLOGIC RADIO REPORTING NETWORK

A computerized network of remote stations in five major New England river basins which report hydrologic data (such as rainfall, river stages and tidal elevations) from index locations on important rivers and streams and in tidal areas for the more timely and efficient operation of flood control reservoirs and hurricane barriers.

LEGEND:

-  RELAY CENTER
-  REPEATER STATIONS
-  REMOTE RECORDING STATION
-  REMOTE REPORTING STATION
-  CORPS OF ENGINEERS
FLOOD CONTROL / HURRICANE PROJECTS

DEPARTMENT OF THE ARMY
NEW ENGLAND DIVISION, CORPS OF ENGINEERS

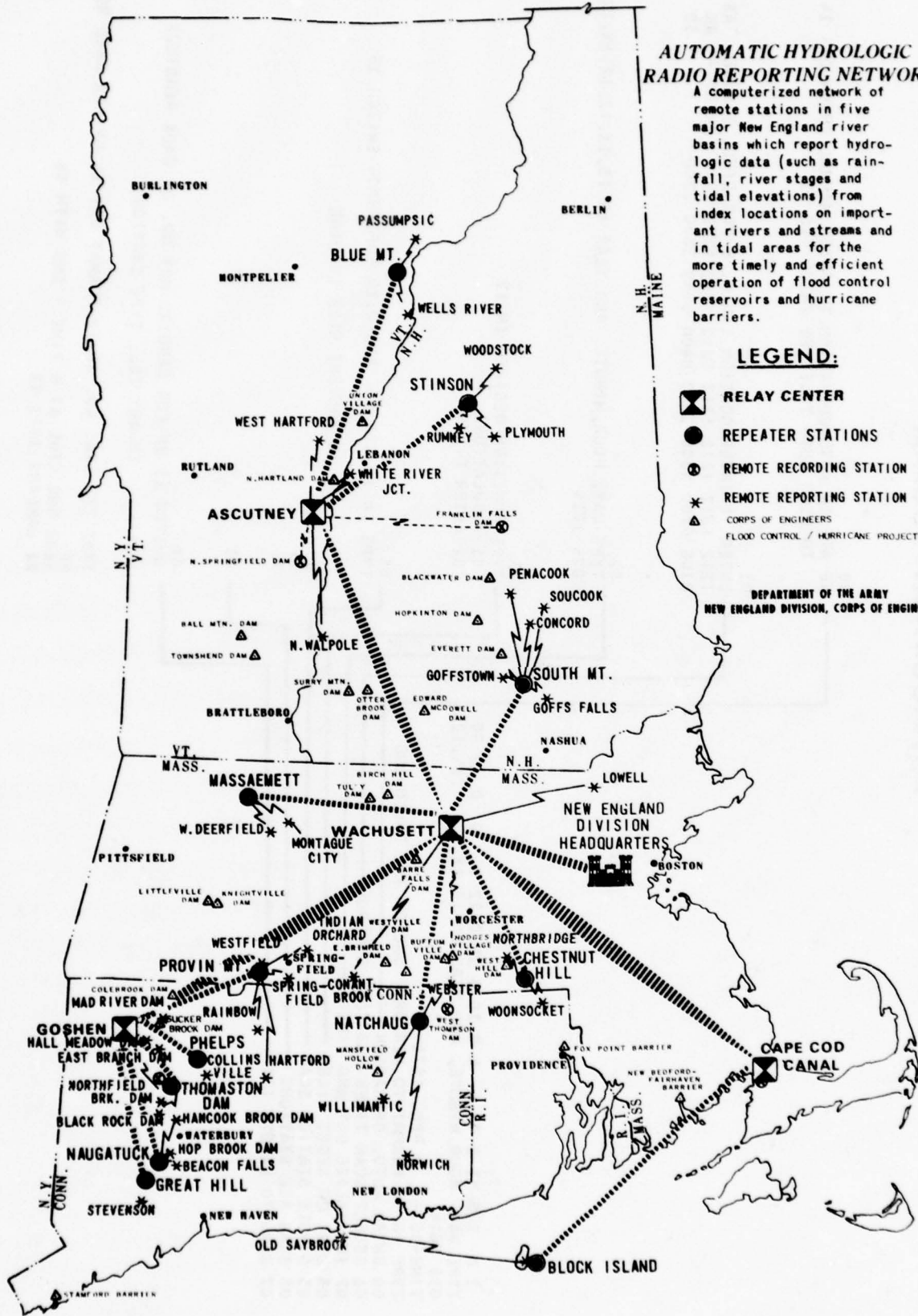

INTERROGATION PROGRAM

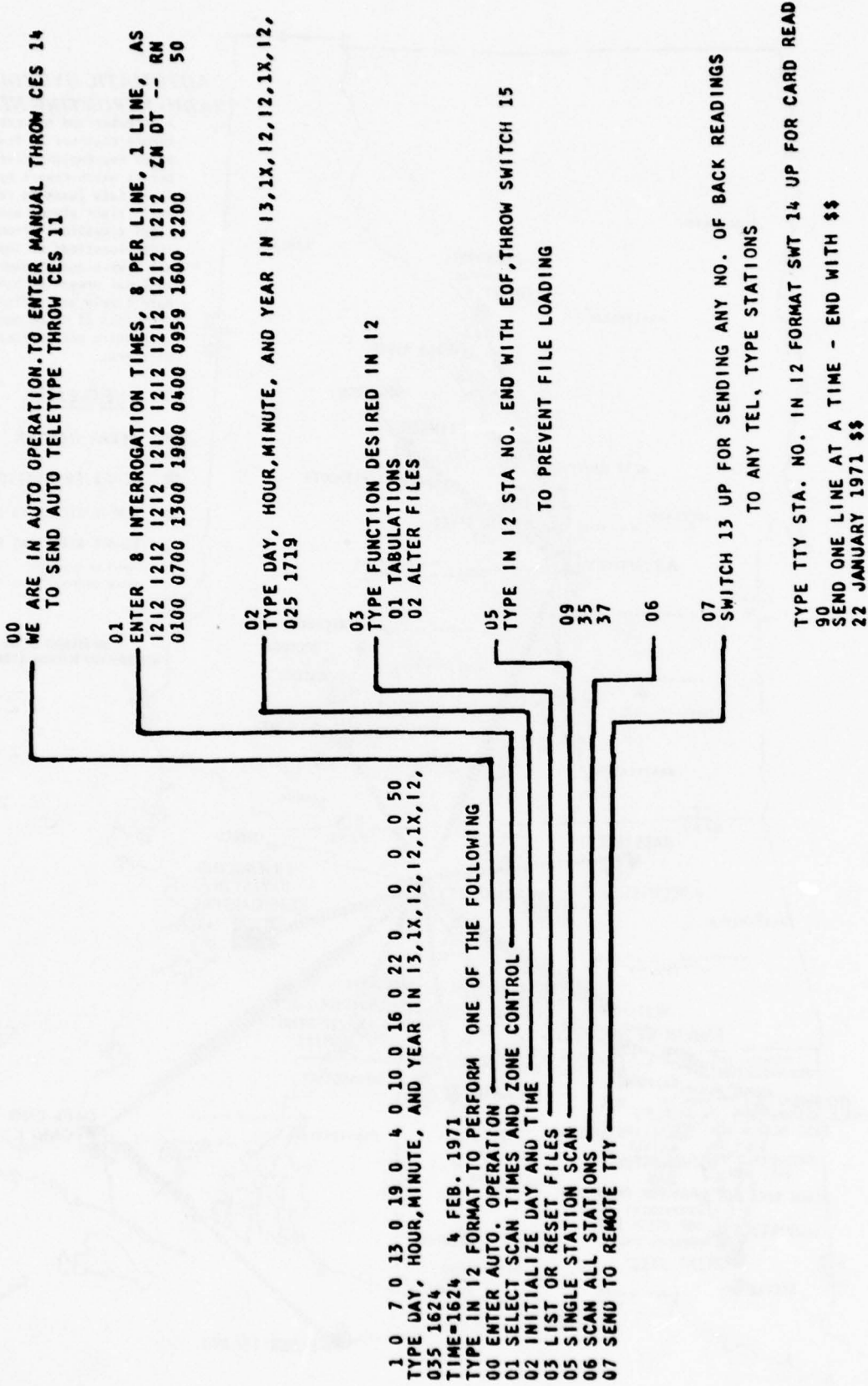

STATION NAME	STA. DAY	NO.	TIME	STAGE FT.	DISCH. CSF	PRECIP. IN.
* * * * * CONCORD	* * * * *	0	2870107	0.	4.00	0.40
		11	2870103	3.30	2100.00	
* * * * * MONTAGUE CITY	* * * * *	0	2870108	0.	4.00	0.40
		6	2870101	9.40	8144.00	
* * * * * WELLS RIVER	* * * * *	0	2870710	0.	4.00	0.40
		38	2870700	0.90	430.00	
		35	2870700	3.00	450.00	
		37	2870700	4.70	708.30	
		6	2870701	8.10	5494.00	
		16	2870701	2.30	3900.00	
		19	2870701	2.60	5800.00	
		39	2870700	1.10	3.70	
		36	2870700	2.90	166.00	
		7	2861900	121.55	632124	
		17	2870701	3.20	49.00	
		15	2870701	0.50	2.00	
		18	2870701	2.90	87.50	
		20	2870701	1.40	175.80	
		24	2870701	4.20	330.00	
		27	2870702	17.20	15.00	
		33	2870702	2.90	234.40	2.00
		34	2870702	2.70	88.50	3.55
		32	2870702	-0.80	172.00	
		8	2861902	121.55	183119	
		9	2870702	1.60	318.40	
		10	2870703	1.60	187.00	
		3	2870703	5.10	29.32	
		11	2870703	3.30	2100.00	
		14	2870703	42.10	1760.00	

SINGLE STATION LISTING
 STATION NAME
 THOVASTON

DAY	TIME	ENDING	STAGE	OUTFLOW	INFLOW	PERCENT USED	INCHES USED
61	1	1000	5.6	340.	340.	0.0	0.00
61	1	1300	6.3	370.	384.	0.0	0.00
61	1	1800	6.6	380.	383.	0.0	0.00
61	2	500	5.6	360.	360.	0.0	0.00
61	2	1100	1.6	580.	660.	0.1	0.01
61	2	1200	1.0	25.	1234.	0.3	0.03
61	2	1400	3.0	30.	1345.	0.8	0.07
61	2	1800	3.0	36.	2849.	3.0	0.25
61	2	2200	4.0	41.	4427.	6.4	0.53
61	3	200	4.0	42.	3029.	8.8	0.72
61	3	900	5.0	46.	2038.	11.5	0.94
61	3	1600	5.2	240.	1685.	13.4	1.10
61	3	1700	5.4	480.	1157.	13.6	1.11
61	4	1000	5.7	490.	1748.	15.3	1.25
61	4	1100	5.8	500.	1153.	15.5	1.35
61	5	800	5.2	760.	1134.	15.6	1.36
61	5	900	5.1	820.	1016.	17.7	1.45
61	5	800	5.8	805.	435.	17.6	1.44
61	6	900	5.7	1250.	587.	16.6	1.36
61	6	800	5.5	575.	865.	16.5	1.35
61	7	900	5.4	772.	1420.	14.0	1.16
61	8	200	5.0	1390.	772.	14.0	1.15
61	8	900	4.9	1360.	615.	11.5	0.94
61	8	1000	4.7	1570.	458.	10.2	0.84
61	9	600	4.0	1340.	1043.	10.1	0.83
61	9	900	2.7	1180.	387.	6.4	0.53
61	10	900	2.2	1340.	432.	2.7	0.22
61	10	2100	2.0	1100.	614.	2.5	0.21
61	11	800	2.0	700.	360.	0.8	0.07
61	11	1200	7.8	460.	342.	0.1	0.01
61	12	600	7.0	410.	381.	0.0	0.00
61	14	300	5.8	390.	407.	0.0	0.00
61	14	900	5.8	390.	398.	0.0	0.00
61	14	1400	6.1	400.	388.	0.0	0.00
61	14	1800	6.0	390.	403.	0.0	0.00
61	17	500	5.2	320.	388.	0.0	0.00
61	18	100	5.0	300.	349.	0.0	0.00
61	18	600	5.5	380.	295.	0.0	0.00
61	19	1700	5.0	300.	391.	0.0	0.00
61	20	1200	4.9	290.	286.	0.0	0.00
61	20	1800	6.8	400.	289.	0.0	0.00
61	21	300	7.0	410.	420.	0.0	0.00
61	22	700	6.0	380.	412.	0.0	0.00
61	23	1500	4.9	290.	377.	0.0	0.00
61	23	2000	5.7	360.	297.	0.0	0.00
61	23	2000	5.3	340.	289.	0.0	0.00
61	24	2000	9.4	520.	370.	0.0	0.00
61	24	2000	9.4	520.	335.	0.1	0.01
61	25	1300	6.0	390.	520.	0.1	0.01
61	26	1900	4.9	290.	300.	0.0	0.00
61	27	1900	4.9	290.	297.	0.0	0.00
61	30	2300	4.8	280.	279.	0.0	0.00

ALL STATION SCAN

20 JUNE 1970

COASTAL STATION	FILE N	YR	DAY	HR	MIN	TIDE	BAROMETER	WIND VELOCITY	WIND DIRECTION
40 BLOCK ISLAND	167	70	171	7	0	1.30 FT	29.89 INCH	16.0 MPH	305.0 DEGR
COASTAL STATION	FILE N	YR	DAY	HR	MIN	TIDE	BAROMETER	WIND VELOCITY	WIND DIRECTION
41 OLD SAYBROOK	156	70	171	7	0	0.90 FT	29.84 INCH	5.0 MPH	283.0 DEGR
STA. NO. AND NAME	-FILE N	YR	DAY	HR	MIN	DISCH.	CFS/SM	STAGE	RAINFALL
38 WELLS RIVER	-1	70	171	7	0	430.	0.2	0.90 FT	
35 WHITE RIVER JUNCTION	164	70	171	7	0	404.	0.1	2.90 FT	
37 N WALPOLE	90	70	171	7	0	264.	0.0	4.10 FT	
39 PASSUMPSIC	165	70	171	7	0	109.	0.3	2.30 FT	
36 W HARTFORD	132	70	171	7	0	382.	0.6	3.50 FT	
7 WEST DEERFIELD	173	70	171	7	0	176.	0.3	1.80 FT	GAS
15 CONANT BROOK	173	70	171	7	0	4.	0.5	1.0 FT	
6 MONTAGUE CITY	176	70	171	7	0	1447.	0.2	5.30 FT	
16 SPRINGFIELD	144	70	171	7	1	2550.	0.3	1.70 FT	
19 HARTFORD	155	70	171	7	1	9100.	0.9	3.70 FT	
17 INDIAN ORCHARD	146	70	171	7	1	693.	1.0	5.10 FT	
18 WESTFIELD	146	70	171	7	1	412.	0.8	3.90 FT	
20 RAINBOW	145	70	171	7	1	107.	0.2	1.20 FT	
24 COLLINSVILLE	148	70	171	7	1	1950.	5.5	7.0 FT	
27 MAD RIVER	138	70	171	7	1	29.	1.6	17.40 FT	
33 WOODSTOCK	-1	70	171	7	1	142.	0.7	2.60 FT	1.54 INCH
34 RUMNEY	151	70	171	7	2	49.	0.3	2.50 FT	3.35 INCH
32 PLYMOUTH	156	70	171	7	2	50.	0.1	98.10 FT	
8 GOFFSTOWN	165	70	171	7	2	54.	0.5	3.60 FT	
9 GOFFS FALLS	153	70	171	7	2	1110.	0.4	3.0 FT	
10 PENACOOK	163	70	171	7	2	471.	0.6	2.10 FT	
3 SOUCCOCK	171	70	171	7	2	45.	0.6	5.40 FT	
11 CONCORD	172	70	171	7	2	2900.	1.2	3.70 FT	
14 LOWELL	159	70	171	7	2	2249.	0.5	42.30 FT	
96	-1	70	171	7	2				
28 HALL MEADOW	148	70	171	7	2	22.	1.9	2.10 FT	
30 EAST BRANCH	163	70	171	7	3	20.	2.2	0.80 FT	0.26 INCH
26 THOMASTON DAM	142	70	171	7	3	272.	2.8	4.80 FT	
31 NORTHFIELD	140	70	171	7	3	15.	2.8	19.90 FT	
29 HOP BROOK DAM	142	70	171	7	3	241.	14.7	20.20 FT	
25 BLACK ROCK	7	70	171	7	3				
22 HANCOCK BROOK	150	70	171	7	3	622.	51.9	77.55 FT	NO REPORT
23 BEACON FALLS	94	70	171	7	3				NVLD
21 STEVENSON	143	70	171	7	4	117.	0.1	1.10 FT	NO REPORT
98	-1	70	171	7	4				
13 NORTHBRIDGE	177	70	171	7	4	560.	4.0	4.20 FT	
12 WOONSOCKET	180	70	171	7	4	20.	0.0	0.20 FT	
1 WILLIMANTIC	171	70	171	7	4	318.	0.8	2.60 FT	
2 WEBSTER	168	70	171	7	4	54.	0.6	4.70 FT	
4 NORWICH	159	70	171	7	4	1149.	0.9	20.70 FT	
5 NATCHAUG PRECTP.	5	70	171	7	4				2.32 INCH

RESERVOIR AND RIVER GAGE PLOTTING PROGRAM

```

00      BEGIN PROGRAM RES1A      ENTER I/O CODE, 00=TYPE, 01=CARD
01      SUBROUTINE RES2B, READ BASIC SHEET LAYOUT DATA
      ENTER SHEET NO., NAME, NUMBERS FOR 9 SHEET LOCATIONS
SN ----- SHEET #      56 57 58 52-53-34 59 60 09-11-14 10
04      MERRIMACK RIVER BASIN
08-03
      ENTER RES1A SUBROUTINE - 12
02      ENTER SHEET NO. - 12
10
      ENTER RES1A SUBROUTINE - 12
03      SUBROUTINE RES2C, READ PLOT SHEET AXIS DATA
      ENTER RES. NO. AND AXIS DATA FOLLOWED BY BLANK IN 12,F3.0,5F5.0
ST DO X10 Y00 YQ1 Y50 Y51
57 36 2 0 1000 510 10
0
      ENTER RES1A SUBROUTINE - 12
04      ENTER SHEET NO. - 12
06      ENTER RES1A SUBROUTINE - 12
05      ENTER RES. DATA STA. DAY, TIME, STAGE, OUTFLOW IN 12,13,212,F9.0,F10.0 EXIT WITH EOF
ST DAY TIME STAGE OUTFLOW
56 36 0830 305.5 6000.
      ENTER RES1A SUBROUTINE - 12
06      ENTER RES1A SUBROUTINE - 12
07      ENTER RES1A SUBROUTINE - 12
08      ENTER RES1A SUBROUTINE - 12
08      PREPARE PLOTTER, SET PEN ON 0 AT LOWER LEFT---PRESS START
      BEGIN PROGRAM RES1A      ENTER I/O CODE, 00=TYPE, 01=CARD
09      SUBROUTINE RES2C, READ PLOT SHEET AXIS DATA
      TYPE IN 12,F3.0,F5.0 FILE OPTION DAY AND 1H/DAY (-1/DY FOR Y AXIS SUPPRESSION)
F DAY 1/DY
34 0.5
      ENTER RES1A SUBROUTINE - 12
10      TYPE FUNCTION DESIRED IN 12
01 TABULATIONS
02 ALTER FILES
  
```

PREPARE PLOTTER, SET PEN ON 0 AT LOWER LEFT
PRESS START

BEGIN PROGRAM RES1A ENTER I/O CODE,
00=TYPE, 01=CARD

ENTER SHEET NO. - 12

CHANGE MODE

READ DATA FOR SHEET LAYOUT

PLOT SHEET LAYOUT

READ AXIS DATA FOR SHEET

PLOT AXIS DATA

ENTER RES. DATA TRANSFORM AND STORE

PLOT ALL RES. DATA FROM START

PLOT REM RES. DATA ONLY

CHANGE SHEET AND MODE

CHANGE TIME SCALE

LIST FILES

ENTER RES.A SUBROUTINE - 12

58
 MACDOWELL
 DAM
 1" = 400 CFS
 1" = 5'
 900

60
 EVERETT
 DAM
 1" = 1000 CFS
 1" = 10 FT
 340

8 GOFFSTOWN
 3 SOUCCOCK
 1" = 1000 CFS

57
 BLACKWATER
 DAM
 1" = 1000 CFS
 1" = 10 FT
 510

59
 HOPKINTON
 DAM
 1" = 2000 CFS
 1" = 5'
 980

10
 PENACOOK
 1" = 2000 CFS

56
 FRANKLIN FALLS
 DAM
 1" = 5000 CFS
 1" = 10 FT.
 300

32 PLYMOUTH
 33 WOODSTOCK
 34 RUMNEY
 1" = 5000 CFS

9 GOFFS FALLS
 11 CONCORD
 14 LOWELL
 1" = 10,000 CFS

MERRIMACK RIVER - SHEET # 4 (7" X 9" Blocks)

APRIL 1970

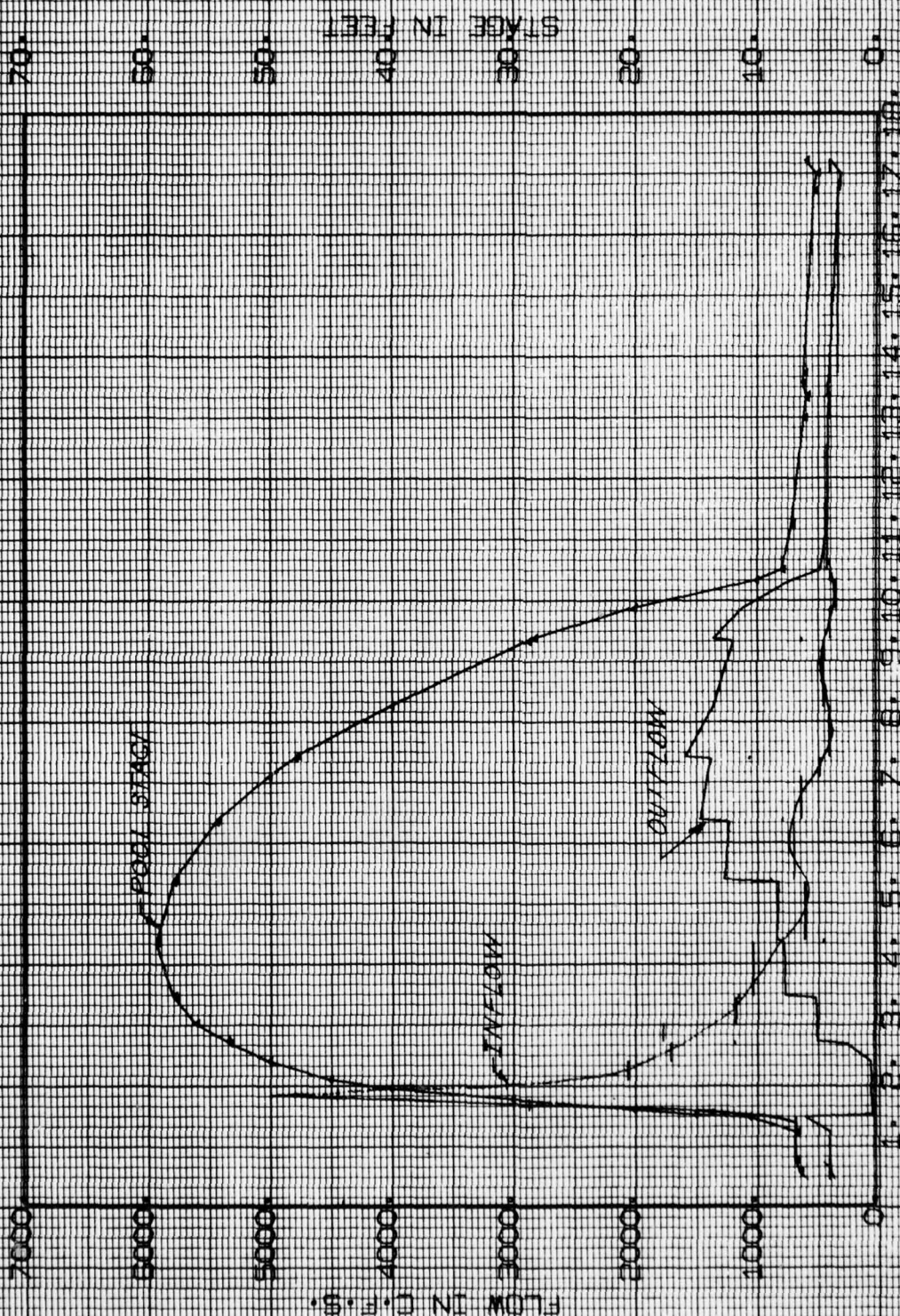

THOMASTON DAM OAF 97.4

COMPUTER TECHNIQUES USED IN
A MASS DATA ANALYSIS

By
D. M. Thomas¹

INTRODUCTION

During the 1970 fiscal year, the Geological Survey undertook and completed nationwide studies of the needs for streamflow information and of the adequacy of available streamflow data for meeting the needs. The objective of those studies was to design an efficient program for providing needed information. The studies required extensive use of computer techniques to assemble and analyze the large mass of streamflow data that has been collected over the past 70 years.

The purposes of this report are to describe some of the computer techniques used in those studies and to announce some of the study products that will be useful in future hydrologic investigations.

Streamflow information evaluation studies were performed in each Water Resources Division (WRD) district office except Hawaii. A project leader was selected in each district who was familiar with the gaging program and with streamflow records, but the experience of these leaders in analytical procedures and in computer methods varied widely. It was necessary therefore to provide a carefully prepared and detailed set of instructions on the desired methods of analysis and on the methods of using computer programs. In addition, a senior member of the Regional or Washington, D.C., headquarters staff was assigned to each district to advise on the analysis and to expedite and coordinate the work.

Nearly all of the machine data assembly and analysis work was done on the Geological Survey's computer system. The primary features of this system are on IBM 360/65 central processing unit located in Washington, D.C., with major terminals located in Rolla, Mo., Denver, Colo., and Menlo Park, Calif. Very little additional computer related equipment was available to district personnel. Perhaps six districts had access to card punching equipment, and a few additional districts had the special typewriters needed for preparing typed input to an optical character reader.

Because of the large mass of data analyzed, the variability in experience of the project leaders, and the general inaccessibility of the project leaders to the computer system; this streamflow evaluation study provided a unique experience in computer applications.

¹Hydrologist, Surface Water Branch, WRD, Geological Survey, Washington, D.C.

In this report the overall framework of the streamflow evaluation studies will be described first, then the computer techniques will be discussed, and finally some products of the study will be announced.

STREAMFLOW DATA EVALUATION METHODS

Methods used in the study of streamflow programs will be described only briefly. More detailed description has been provided by Carter and Benson (1970) and in reports for each WRD district except Hawaii.

The study consisted of four steps: (1) establishing program goals in a quantitative form, (2) assessing the adequacy of existing data for meeting those goals, (3) considering alternate means of meeting goals for which available data are insufficient, and (4) proposing the most efficient possible future streamflow information system. Another feature of the study was that all streamflow data was considered to be of four types: (1) data for current use, (2) data for planning and design, (3) data on long term trends, and (4) data on stream environment. Table 1 shows the study framework.

Current Use Data - The goal for current use data; which is data needed for management, assessment, or surveillance; is to provide gaging records of any desired accuracy at any necessary site. In the evaluation studies the current use of data was determined for all active gages.

Planning and Design Data - Statistical characteristics of flow may be needed by planners and designers at any point on any stream. The goal is to provide these data with an accuracy attainable from 10 years of observed record on minor streams and with an accuracy attainable from 25 years of record on major streams.

Since it is impossible to operate gages at every point where data may be wanted, a method is needed for transferring information from the sample of gaged points. Different transfer methods are used for natural and non-natural streams.

On natural flow streams, multiple-regression relations defined between a flow characteristic and drainage basin characteristics provide an effective method of transferring information. Once the relation is defined, basin characteristics above an ungaged point may be determined and used in the relation to estimate the flow characteristic. A measure of the accuracy of such estimates is provided by the "standard error of estimate".

In the data evaluation study, multiple-regression relations were defined to estimate a wide range of flow characteristics. The accuracy of those relations was then compared with the accuracy obtainable from 10 and from 25 years of observed record. If the regression estimates were found to be of equal or superior accuracy, then the available data were considered adequate to meet the goal.

For non-natural streams a systems model approach will be required to define flow characteristics. Definition of systems models for all regulated streams was beyond the capabilities available for this study, so the evaluation was limited to setting priorities for future stream studies and assessing the amount of available data in the system.

Long-term trend Data - Long-term, homogeneous flow records are needed for time-series analysis and for adjusting nearby short-term records. In the evaluation studies, the long-term records of natural-flow streams which are expected to remain in a comparable future condition were identified and from this group about 450 gages were proposed for indefinite future operation.

Environmental Data - Environmental data includes a broad category of information such as flood prone area delineations, flood profiles, time-of-travel, drainage basin characteristics, and so forth. In the evaluation studies, the needed types of environmental data were determined, and plans proposed for providing it.

COMPUTER TECHNIQUES

Computer techniques used in the evaluation studies were concerned with judging the adequacy of available data for providing planning and design information. The steps taken in the study were: (1) expansion and creation of data files, (2) computation of flow characteristics from the data files, (3) definition of basin characteristics, and (4) multiple-regression analysis using flow characteristics as dependent variables and basin characteristics as independent variables.

Data Files - Two data files, the daily discharge file and the flood peak file, provided input to a set of computational programs used to evaluate the statistical characteristics of a streamflow record.

A sequential, magnetic tape file containing about 185,000 station-years of daily discharge record existed at the start of the study. During the study, 23,000 additional station-years of record were merged into the file. The file now contains all daily records over 10 years in length (through the 1967 water year) for all natural or virtually natural flow sites and for all regulated flow sites where monthly flow values can be adjusted on the basis of storage and diversion records to represent natural flow conditions with an error of less than 10 percent.

Three techniques were used for entering daily discharge records into the file -- punch cards, typed sheets for use with an optical-character-reader, and a 7/8-inch wide, 7-channel, paper tape created by an add-punch machine. Most data were handled by punch cards and to the extent possible in-house punch facilities were utilized, although some cards were prepared by commercial firms. A few district offices prepared relatively small data batches by typing. The add-punch tapes are inefficient and were not used extensively.

All data were accepted by a 10-point edit program before being merged into the tape file. The inclusion of monthly and annual runoff totals in the data stream greatly facilitated the location and correction of data errors.

A new data file, the flood peak file, was created during the study. This is an index-sequential file on magnetic disk and contains information on the gaging station number and name, drainage area, stage datum, and for each water year it provides the date, stage, and discharge of the peak flow, the date and annual maximum stage if for a different date than the peak discharge date, and a system of codes about accuracy, qualifying information, effects of regulation or diversion, and historical information.

Creation of this file was a major undertaking. All flood records over 10-years in length and published in Geological Survey reports were entered into the file by the typed optical-character-reader method. The number of gaging records has not been counted, but is believed to exceed 12,000. A listing of the file data was sent to district offices for checking before the data were used in computational programs.

Computation of Flow Characteristics - Statistical flow characteristics were computed from the data files by three library programs. Each project leader was instructed to inspect closely the program output for possible data errors and also to adjust computed flow characteristics as necessary on the basis of historical information or data "outliers".

Programs used in computation of flow characteristics were: (a) - Stream-flow Statistics (A969) - This program provides magnitude-duration-frequency characteristics of daily discharges. Basic output is (1) tables of daily flow duration, (2) tables of highest mean flows for 1, 3, 7, 15, 30, 60, 90, 120, 183, and 365 or 366 consecutive days in each water year, and (3) tables of lowest mean flow for 1, 3, 7, 14, 30, 60, 90, 120, 183, and 365 or 366 consecutive days in each climatic year. Optional output may be provided for any duration of highest or lowest flows and includes several statistics of natural and log-transformed data, coordinates of a log-Pearson III frequency curve, and a plot of the data and computed curve. (b) - Flow variability (W4422) - This program computes statistics describing the annual and monthly characteristics of a flow record. Output includes means, variances, standard deviations, coefficients of skew and coefficients of variation. Also provided are the first-order serial correlation coefficient of annual flows and a matrix of serial correlation coefficients for monthly flows with lags of one, two and twelve months. Options allow computations on natural and log-transformed data. (c) - Log-Pearson Type III (W4014) - This program fits a Pearson type III probability distribution to the base-10 logarithms of peak flow observations and provides related statistics. A line-printer formed plot is provided to visually check the fit of the computed curve to the data points.

Computation of Basin Characteristics - Several drainage basin characteristics were defined for about 6300 gaged sites with defined flow characteristics. These basin characteristics were ones that might logically be related to areal differences of flows and ones that could be defined from readily available maps or tabular data. As a minimum the defined basin characteristics included basin size, main channel length and slope, lake and pond areas, forested area, mean elevation, annual precipitation, and precipitation intensity. For northern sites average January temperature and a snowfall index were defined. Soil Conservation Service soil scientists provided information to define a soils index for all basins in most districts. Additional indices of climate and topography were defined in many districts.

Regression Analyses - Stepwise multiple-regression analysis was used to define relations between a flow characteristic as the dependent variable and the basin characteristics as independent variables. The standard error of estimate of the relation containing the most independent variables that were all significant at the 5 percent level was used as the estimating accuracy for comparison with the accuracy attainable from 10 or 25 years of observed flow records.

At least 37 flow characteristics covering the range from lowest to highest flows were each used as dependent variables. For simplicity, the relations were assumed to be linear when variables were transformed to logarithms.

The regression analyses were performed with a group of interlocking library programs known as STATPAC. Geological Survey programmers prepared STATPAC for the reduction and statistical analyses of data presented in the form of a two dimensional matrix. For the data evaluation studies, the data matrix consisted of flow and basin characteristics in columns with each row containing data for a gaging station. The data matrix was prepared on punch cards.

The analytical procedure used in most studies was to first define district-wide regression relations for selected flow characteristics. The areal distribution of residual errors were then studied to suggest additional basin indices for use as independent variables, or to suggest areal groupings for which the relations should be defined. Regression relations were then defined for all flow characteristics using additional basin indices or selected areal groupings. This process was repeated until the project leader was satisfied that the relations were as refined as possible.

PRODUCTS OF THE STUDY

The primary product of the data evaluation study is a program proposed for efficiently providing needed streamflow information. There are, however, several additional products that will be useful in future hydrologic investigations. A few of these products are:

- (1) An updated and expanded magnetic tape data file which now contains daily discharges of all except the highly regulated flow records more than 10 years in length.
- (2) A new data file of annual flood peak information.
- (3) Flow characteristics describing the daily, monthly, annual, and/or flood peak characteristics for all sites with more than 10 years of record on virtually natural flow.
- (4) Indices describing the topographic and climatic characteristics of over 6300 drainage basins with 10 years or more of virtually natural flow records.
- (5) Regression relations that may be used to estimate flow characteristics needed by planners and designers for ungaged natural flow sites.
- (6) Experience and competence in each District office in analytical and computer techniques.

SUMMARY

The Geological Survey has completed a nationwide study of streamflow information needs, of the adequacy of available data for meeting those needs, and of an information system to provide for future information needs.

Only through computer techniques was it possible to assemble and process the large mass of existing streamflow data and then perform an objective analysis of those data.

Although the primary product of the study was the design of a streamflow information system, some byproducts of the study will be helpful in future hydrologic investigations.

REFERENCES

- Carter, R. W., and Benson, M. A., 1970, Concepts for the design of a streamflow data program: U.S. Geol. Survey open-file report.

Table 1.—Framework for design of data collection program

Type of data	Current use	Planning and Design				Long-term trends	Stream environment
		Natural Flow		Regulated Flow			
		Minor streams	Principal streams	Minor streams	Principal streams		
Goals	To provide current data on streamflow needed for day-by-day decisions on water management as required.	To provide information on statistical characteristics of flow at any site on any stream to the specified accuracy.				To provide a long-term data base of homogeneous records on natural-flow streams.	To describe the hydrologic environment of stream channels and drainage basins.
Drainage area limits	Full range	Less than 500* sq mi.	Greater than 500* sq mi.	Less than 500* sq mi.	Greater than 500* sq mi.	Full range	Full range
Accuracy goal	As required	Equivalent to 10 years of record.	Equivalent to 25 years of record.	Equivalent to 10 years of record.	Equivalent to 25 years of record.	Highest obtainable	As required
Approach	Operate gaging stations as required to provide specific information needed.	Relate flow characteristics to drainage basin characteristics using data for gaged basins.	Operate gaging stations to obtain 25 years of record (or the equivalent by correlation) at a network of points on principal streams; interpolate between points.	Develop generalized relations that account for the effect of storage, diversion or regulation on natural flow characteristics.	Utilize analytical model of stream system with observed data as input to compute homogeneous records for both natural flow conditions and present conditions of development.	Operate a number of carefully selected gaging stations indefinitely.	Observe and publish information on stream environment.
Evaluate available data	Identify stations where data is used currently and code the specific use of data.	Develop relationship for each flow characteristic and compare standard error with accuracy goal. Evaluate sample.	Lay out network of points on principal streams and compare data available at these points with goal.	Appraise type of regulation, data available, and areas where relationships are needed.	Identify stream systems that should be studied using model approach and determine data requirements.	Select two stations in each WRC subregion to operate indefinitely for this purpose.	Evaluate information available in relation to goals.
Design future program	Identify goals that have not been attained. Consider alternate means of attaining goals. Identify elements of future program.						

* May be varied with terrain and hydrologic conditions.

COMPUTER TECHNIQUES USED IN A MASS DATA ANALYSIS

Discussion

Question, Mr. Mirick: Is flow duration done on a seasonal frequency?

Reply, Mr. Thomas: Seasonal discharge-duration-frequency data may be obtained as an option of the Streamflow Statistics program. This information has already been computed for some states and is available in WRD District offices.

Question, Mr. Sharp: Mr. Thomas, you have talked a lot about data files, retrieval problems and so forth. You also briefly mentioned the STORET system of the Environmental Protection Agency that is used to store water quality data. Are you knowledgeable of this system, especially any problems associated with use, and if so, would you please comment in this regard?

Reply, Mr. Thomas: I have only limited knowledge of EPA's STORET file. I do know that any agency may enter data into the file, and that a variety of agency codes and station identification codes have been used, thereby resulting in some problems for retrieval of information collected and stored by a different agency.

The Geological Survey has a newly-designed quality of water data file on magnetic tapes. This file contains all of the quality data on surface water that the Survey has collected since the 1967 water year and much of the data collected since the 1959 water year. Only a small amount of data on quality of ground water has been entered into this file.

Question, Mr. Matthews: What would be the cost per station of streamflow statistics and flow variability program printouts and/or the costs of copies of the daily flow records?

Reply, Mr. Thomas: There is no accurate way to estimate costs since it varies with job size, with location of data on tapes, and with program options selected. For cost estimates we figure that the Flow Variability and Streamflow Statistics programs each cost about \$5.00 per station regardless of record length. Transfer of daily flow records costs about \$0.25 per station-year on 7-channel tapes and somewhat less-perhaps \$0.15 per station-year on 9-channel tapes.

A CONVERSATIONALLY-ORIENTED ENGINEERING COMPUTER SYSTEM

By

Robert L. Renner¹

INTRODUCTION

The Corps of Engineers installed its first electronic digital computer in the late 1950s. Today it owns or leases 70 electronic computers. The computer is used in some manner in a great number of Corps functions. It is considered to be an essential engineering tool by many Corps engineers.

In adapting the computer to engineering problem solving, the Corps has made mistakes; it has had false starts and followed paths that have led to frustration; but it has learned. First, it has learned that although the computer is a powerful tool, it is not the answer to every problem. Second, it has learned when to apply the computer and when to seek more efficient manual or semi-automatic methods. Third, it has learned that it is better to make the computer speak the language of the user rather than to make the user speak the language of the computer.

A GROWING CORPS COMPUTER POTENTIAL

The Corps has been moderately successful in applying the computer to engineering problem solving. However, it now appears that the Corps is standing on the threshold of great promise for making the computer the indispensable engineering tool it is capable of becoming. This optimism is attributed to four significant factors:

- A new generation of computer-oriented engineers are now assuming positions of responsibility within the Corps of Engineers. Many of them have been associated with the Corps early experience in adapting the computer to engineering applications and they appreciate its power as a design aid; others are college trained in computer science and bring with them a depth of understanding in computer technology.

- New and sophisticated computer equipment is becoming available; equipment which is faster, easier to use and less expensive to operate than ever before. A particularly significant equipment development has been the time-sharing computer system.

- A library of meaningful engineering computer programs is being developed within the Corps of Engineers. Programs in this library will have been documented, thoroughly tested and approved by competent authority for use in planning, design or construction.

¹Chief, Research and Training Section, Structural Branch, Civil Works Directorate, OCE

• A conversationally-oriented engineering computer system has been developed which will allow any engineer to use all of the programs in the Corps library with an absolute minimum of effort. This system provides linking and chaining of computer programs and it communicates with the user in his own discipline-oriented language.

The development of a meaningful computer potential within the Corps of Engineers began in 1965. It started with an in-depth study of our engineering processes and the identification of problems associated with computerizing these processes. The engineer normally receives assignments in the form of mission requirements. These are used by the engineer to develop project concepts. Project concepts form the basis for design criteria; design criteria are used in making design decisions and in developing a specific design. This design is evaluated to determine how well it satisfies mission requirements. If inadequacies exist, the project concepts are altered and the design process repeated until a satisfactory design is achieved.

Most aspects of this process can be computerized provided the engineer can effectively communicate with the computer. This communications problem has been difficult because of these factors:

• The engineer understands the language and processes of his profession. His principal concern is solving engineering problems. If we give him a computer as a design aid, but force him to become a computer programmer in order to use it, we have more than likely complicated the design process.

• Since engineering is an iterative process, the computer must be accessible and capable of responding to the engineers' requirements in a relatively short period of time. Otherwise, it can become a liability rather than an asset for the next iteration in the design process is always dependent upon the results of the previous one.

• Engineering is not only an iterative process, but one which requires ingredients of experience and creative ability in order for the design to satisfy the mission need. The computer can easily provide computational speed, analyses and comparisons in problem solving (some experience can be programmed into the computer but that is often limited because of the great number of variables involved) and man can provide the experience and creative ability. A proper man/machine balance is often difficult to achieve, but once it has been done, it provides an unbeatable problem solving combination.

• There are no universally acceptable standards for developing engineering computer programs. The data input requirements, data element sizes, variable name assignments, solution techniques and data output formats are usually unique to each program. This non-uniformity between programs makes it difficult for the normal user to acquire and use programs developed by others. Although this problem is not restricted to engineering, it is especially critical in problem solving where the solution technique is the predominant factor. The engineer user must be satisfied that the computer solution is valid for his set of conditions; this requires that he know what parameters and assumptions were used in the programs development.

EXPLOITING THE COMPUTER AS AN ENGINEERING TOOL

Once we had evaluated our processes and identified those computer problems which were inhibiting us from fully exploiting the computer as an engineering tool, we could explore techniques for solving them. In reviewing the problems it was found that they could be grouped into three principle areas: (1) providing better and more easily accessible hardware, (2) developing a library of computer programs that would be pertinent to our work and which could be relied upon to produce satisfactory solutions and (3) to make it easier for the engineer to communicate with and use the computer. Corps goals have been established and are being implemented to address these problem areas.

COMPUTER HARDWARE

The first major goal established has been to make the computer more easily accessible to the engineer professional. A program to up-grade Corps of Engineers computer facilities was developed in 1965. Its implementation began in 1969 and will be completed in 1972; at that time every Corps office will either have an installed computer or have access to one. In addition, a large scientific computer will be installed in the Corps' Waterways Experiment Station in Vicksburg, Mississippi, in 1971. This machine will be available, via time-sharing, to all other Corps facilities. The acquisition of satisfactory terminal devices, at design level, which will communicate with installed or leased equipment, will provide every engineer the power of the computer for problem solving.

COMPUTER LIBRARY

The second major goal has been the development of a Corps-wide engineering computer programs library. In developing the system to achieve this goal, maximum use of previous in-house work, as well as that of others, is being made in the applications area. The program now being implemented consists of three efforts:

- An Engineering Computer Programs Library has been established at the Waterways Experiment Station. It serves as a repository and distribution center for all agency approved computer programs.

- Approval procedures have been established by which all engineering computer programs must pass in order for them to become a part of the library. Those programs which attain approved status may be used in design without the designer being required to document his solution technique in a design memorandum; he need only refer to the program by number and provide the input used for the problem solution.

- Engineering computer program documenting standards have been established and published.

AD-A052 603

HYDROLOGIC ENGINEERING CENTER DAVIS CALIF

F/G 8/8

PROCEEDINGS OF A SEMINAR ON COMPUTER APPLICATIONS IN HYDROLOGY --ETC(U)

FEB 71 L R BEARD, D R BURNETT, R E BENNION

UNCLASSIFIED

HEC-SP-04

NL

3 of 3
AD
A052603

END

DATE

FILMED

5 -78

DDC

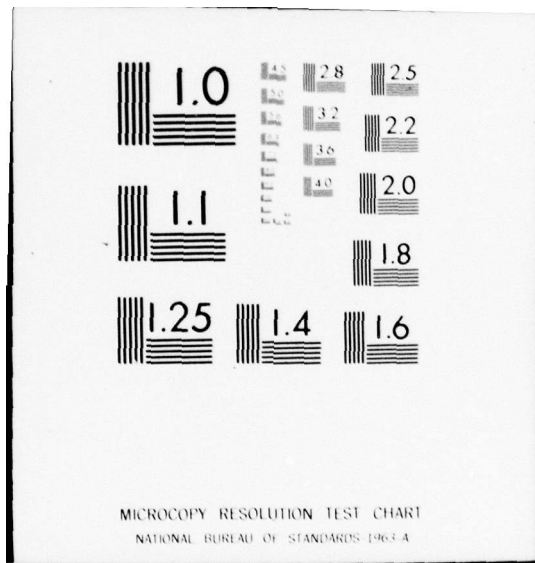

MICROCOPY RESOLUTION TEST CHART
NATIONAL BUREAU OF STANDARDS-1963-A

COMMUNICATING WITH THE COMPUTER

The last major goal has been to make it easier for the engineer to communicate with and use the computer. The design and implementation of a program to achieve this goal has been particularly difficult. Our first efforts have been two-fold:

- An Engineer Computer Training Program has been developed. It defines a minimum level of computer competence for every engineer. The type of training and level of difficulty is commensurate with the engineers' duties and responsibilities. The implementation of this program will assure the Corps of a high degree of computer competence among its engineering staff.

- A conversationally-oriented engineering computer system has been developed which will allow an engineer to use any program or group of programs in the library with an absolute minimum of effort. This system communicates with the user in his own language and produces results that he can understand. The development of the system represents a break-through in our search to make the computer a tool for every engineer. The Mark I system operates in real-time and has been titled as "CORPS" (an acronym for Conversationally Oriented Real-Time Program-Generating System).

"CORPS" CONCEPTS

The development of the "CORPS" is perhaps our most promising effort for creating a properly balanced engineer/computer design team. The statement that the system was developed is misleading since the original systems work was directed along other lines. It is perhaps more explanatory to say that the system was discovered.

It all began when it was decided that a survey would be made of the Corps of Engineers to determine what computer programs were in use for hydraulic design. This program envisioned that all the hydraulic design programs would be collected, an engineering evaluation made of them to determine which of them could be used Corps-wide, and those considered as appropriate would be documented and placed in the WES Library for distribution.

In order for the hydraulic design engineer to use the programs in the library, either as individual programs or in some group order, it was usually necessary for him to write a small computer program. The writing of these small programs was not too difficult, provided the user was a computer programmer, since all the basic programs were written in a common language, FORTRAN, and they were well documented. However, as every programmer knows, it is easy to make mistakes in coding no matter how simple the task, so every new program required some debugging and testing prior to its being used in production.

The development of these hydraulic design subroutines, to be used as a system, was clearly a step in the right direction, for each program furnished was well defined, tested and could be relied upon to provide a satisfactory answer if used within the limits imposed. However, the requirement that the

hydraulic designer be a computer programmer in order to use the system was exactly opposite to what we had been preaching; we were, in fact, compounding the design effort. Realizing this, an Executive System was developed to provide the communications link between the set of system subroutines and the engineer user. The Executive System required that every subroutine in the system contain a preamble in FORTRAN language. This preamble contained a list of parameters required to run the program, any input, output or computation options available, variable definitions, a brief summary of the program and any other data pertinent to making the system operate. The Executive System was capable of reading the preamble, converting it into English and presenting system requirements to the user in hydraulic terms. The engineers responses were used by the Executive System to write a new program containing all the basic subroutines requested, as overlays, in the new program. The Executive System was performing the same programming function that the engineer user had previously performed but it could do it flawlessly. It would automatically generate a program, including all applicable subprograms, in response to engineering language input. We had succeeded in relieving the hydraulic engineer of the programming task when using subroutines in our system.

The mechanics for using the system were quite elementary. The engineer would access the computer via a time-sharing computer terminal. He would converse with the computer in English; telling it which programs he wanted to run and in what order, supplying the inputs demanded by the computer and reviewing results as necessary. The entire process could be easily learned by any hydraulic engineer in just a few minutes. The basic subroutines in the system were all developed by other hydraulic engineers so they were written in the language of the user. New hydraulic design programs were added to the system as time permitted. The only requirement for adding new programs was that each of them contain a preamble conforming to system specifications. As time passed, programs other than hydraulic design were demanded by the users. Thus, the system we now call "CORPS" was born.

SYSTEM DETAILS

The present "CORPS" was developed for the General Electric 400 series computer of the type being procured by each Corps Division office. It is the Mark I system and is operational on time-sharing only. A Mark II system is now under development. It will include many operational improvements over the Mark I system except it will still be programmed for time-sharing only. A proposed Mark III system will extend our capabilities to batch and remote-batch. Later adaptations will be made to apply the system to other computers.

A system schematic of "CORPS" is shown in Figure 1.

Operational details of the system are as follows (circled number refer to activities shown in Figure 1);

• Sequence I

If the user wishes to develop a new FORTRAN computer program which utilizes any subroutine or group of subroutines in the program library, he starts with Sequence I. Thus:

(1) He addresses the computer via a remote terminal device and tells it to run the Executive Program. The computer asks the user if he would like system details or subroutine content. If he does, the computer accesses the disc library (2) to retrieve the data and displays it at the terminal (3). The computer then asks the user to enter the subroutines desired and in the order he wishes to run them. He can specify the same subroutine more than once if he so desires. Using these input data, the computer accesses the disc FORTRAN Library (2) to retrieve the programs in run order. It interprets the preamble for each program and asks the user to supply any data required to assemble the new program. The Executive System utilizes user supplied data and the preamble content to develop a new FORTRAN IV program. This is stored on disc storage (4). The program developed by the Executive System is a valid FORTRAN IV computer program and can be used on any system which will accept GE FORTRAN. As previously mentioned, the conversation between the user and the computer is in English language and specifically oriented to the discipline involved.

• Sequence II

If the user wishes to compile an object program from the source program he has just created, or from a source program he had previously created, he would follow Sequence II. Thus:

(5) The user asks the computer to run his program. (6) The computer inputs a copy of the program from disc storage, it inputs a copy of the basic subroutines from the disc library (7). It compiles the program and stores the object program back on disc storage (9) and in computer memory (8). (10) The computer runs the object program either with or without input from the user. The computer accesses the disc storage to run subroutines in overlay mode (11). It accesses the disc storage to retrieve or store data required for program execution (12). Program output can be printed hard copy (13), disc storage (12) or both. If the user wishes to rerun the program using different input data, he begins Sequence II at Step (10). In this instance the computer accesses the disc storage for the object program and begins processing.

ADVANTAGES OF THE "CORPS" CONCEPT

The "CORPS" concept provides the following advantages over normal computer library concepts:

• Any user can communicate with the computer in an effective manner without becoming a computer programmer.

- The system communicates with the user in his own discipline-oriented language.
- The system provides instant access to a great variety of meaningful computer programs.
- Dynamic dimensioning of computer memory is allowed. Thus, the user can sub-divide large programs into logical units and run them efficiently on the GE 400 series computer (or similar equipment).
- The system can be easily converted to any computer since it operates in FORTRAN.
- The system will be available for Corps-wide use in 1971.
- The system reduces computer programming and debugging time.
- The system was developed by engineers for engineers.
- The present Mark I system is operational. The Mark II, Mark III, etc. systems will enhance capabilities but pay-offs begin at once.

CONSTRUCTION OF THE PREAMBLE

A computer program that is written in FORTRAN and is operational on the GE 400 series computer, can be used in the "CORPS" system provided it has been modified in accordance with system specifications. This modification is relatively simple and consists of the addition of a preamble in the form of comments statements. These statements are interpreted by the Executive System and form the basis of a new FORTRAN program which is written by the Executive. The Executive can recognize the type of statement and its content by the range of its line number, as follows:

<u>Line No. (Not statement number)</u>	<u>Type of Statement</u>
001 to 009	Program name
011 to 499 (Odd numbers)	Notes to user
010 to 500 (Even numbers)	Dimensions, Equivalence, Type and Data Initialization Statements
501 to 899	Overlay Calling, Read, Print, Assign and other statements
900 to 950	Program Options
951 to 999	Program Summary
Line numbers ending in a code letter for comments	Special options selected at compile time
1000 to 99999	FORTRAN Program or subprogram

"CORPS" DEVELOPMENT SCHEDULE

The present Mark I, "CORPS" system contains about 20 hydraulic design subroutines; it is planned that as many as 100 programs will be available in the system by 30 June 1971, and in excess of 500 by 30 June 1972. The programs will cover every engineering discipline used in the Corps of Engineers. Although "CORPS" is not the ultimate in computer programs or the answer to every computer problem, it does allow any engineer to access the computer, in a meaningful way, with little effort or previous computer training. The user must be intimately familiar with the problem to be solved and know what he can expect in the way of computer solutions. He can tailor every problem solution to his specific requirements, provided there are basic programs available which he can use. If he needs a computer program other than those already in the system, he can develop one or have one developed.

CONCLUSIONS

The future of the computer in the Corps' engineering design business can be assured if it becomes a truly useful device for every problem solver. In an effort to make the computer an indispensable engineering tool, the Corps is acquiring responsive computer equipment, building a library of meaningful and useful computer programs, training engineers in computer technology and providing him with a machine which speaks his own language.

FIGURE 1
SYSTEM SCHEMATIC

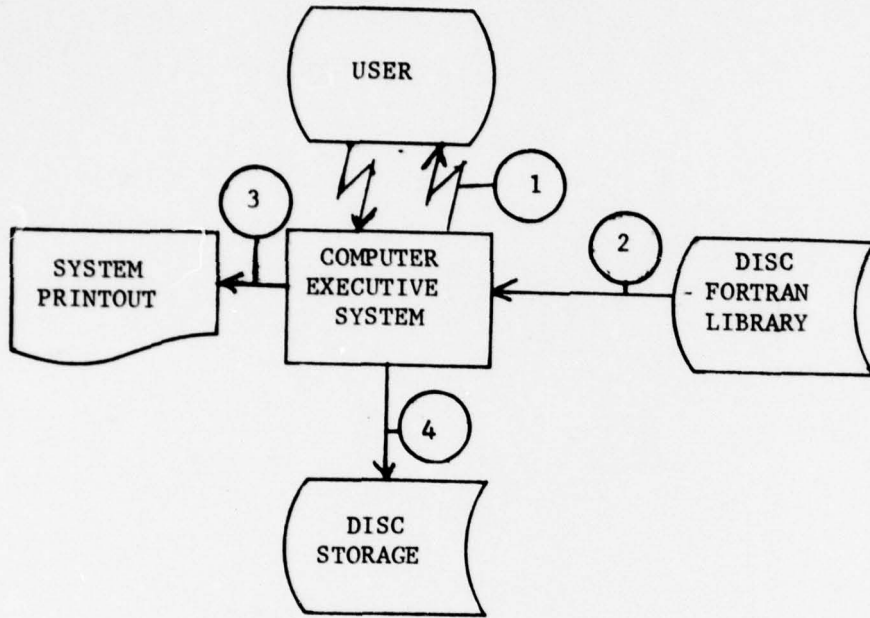

SEQUENCE I

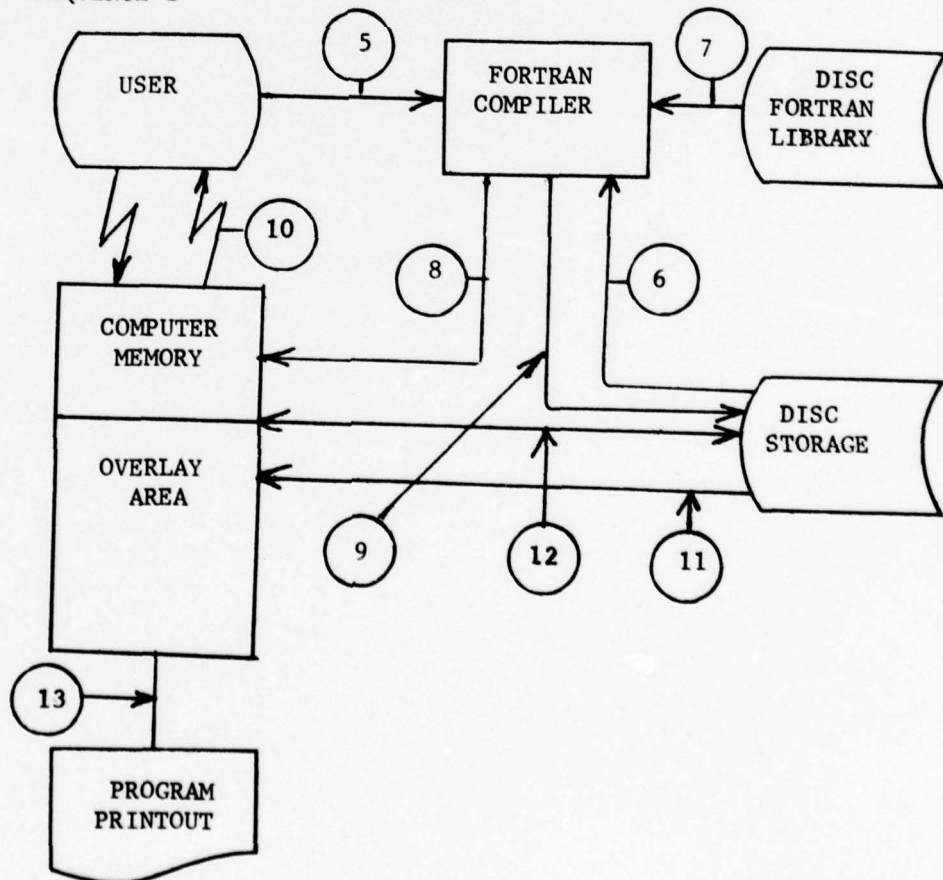

SEQUENCE II

CONVERSATIONALLY-ORIENTED ENGINEERING COMPUTER SYSTEM

Discussion

Question, Mr. Fredrich: One thing about the proposed system that is rather disturbing to me is that it appears that the system is designed to encourage the engineer to use the computer without bothering to learn too much about programming. Isn't it possible that the system will remove the motivation for engineers who really should be doing more to familiarize themselves with computers and with programming?

Reply, Mr. Renner: I believe that an engineer can effectively use the computer without becoming a computer programmer. However, if he is to be successful he must be knowledgeable of the capabilities and limitations of the systems he is using and the programs involved. In my opinion, the use of a computer for engineering problem solving is similar to using design tables; if you know how the tables were derived and their limitations you should certainly use them rather than recalculate the information each time you require an answer.

Question, Mr. Matthews: What about priorities?

Reply, Mr. Renner: In the time-sharing mode the computer gives each user a time-slice of the central processor. Normally, in a mixed mode operation, time-sharing has priority.

Question, Mr. Mirick: How reliable is the remote terminal over telephone lines due to background noise or interference?

Reply, Mr. Renner: The use of a computer via telephone lines can result in transmission errors and false data, unless you take adequate precautions. The lines used must be conditioned for data transmission and you should provide for error checking in the equipment, if possible.

Comment, Mr. Bennion: Your basic proposal seems to provide a practical way of helping program users to develop generalized programs, such as offered by HEC, by providing a convenient means of grouping smaller programs for application to a particular problem.

Reply, Mr. Renner: This is true. The system we have developed will allow a user to generate a sophisticated computer program by grouping smaller, but well tested, programs together.

REQUIREMENTS FOR
REVIEW OF ENGINEERING COMPUTER PROGRAMS

by

Warren L. Sharp¹

INTRODUCTION

Engineers within the Corps have been actively engaged in computer program development and use for well over a decade, and the need for guidance regarding review of existing and future programs is long over due. I would like to express a few words relative to this need, followed by a proposal for actually performing reviews.

A tally of most engineering type programs included in the latest printing of the Corps catalog of engineer computer programs (Engineer Pamphlet 18-1-3, 14 Feb 69), yields the following numbers of programs when grouped according to closely related disciplines: hydrologic/hydraulic/reservoir regulation, 817; structural/concrete/soil mechanics, 684; geodesy/surveying, 569; mechanical/electrical, 48; and earthwork/dredging, 185. Fortunately, there are specialized organizations in the Corps that are capable of reviewing programs in the first of these groups, i.e., hydrologic, reservoir regulation and hydraulic engineering. However, the number and complexity of programs within the other disciplines mentioned above is an indication of the problems to be expected in formulating review procedures for those areas.

There have been recent activities within the Corps designed to improve computer program development and utilization. These are: (1) establishment of a library of engineering computer programs (ECPL) at the Waterways Experiment Station; (2) development of coding standards and documentation requirements; and (3) installation of small to medium sized computers in all of the Division and District offices. In addition, future activities are planned regarding computer oriented training, especially at the supervisory and management levels, and the provision of specialized assistance on a very limited scale to engineers in those disciplinary areas where such assistance is not presently available. Strange as it may seem, until very recently there has been no guidance or requirements for the review of engineering programs, and very little guidance for their development. To permit such a long time lapse after appreciable utilization of the computer for engineering computations became commonplace, without any requirements for review, has been somewhat of a management oversight (to put it mildly). The major reason there has

¹Chairman, Field Assistance Task Force IV, Engineer Computer Concepts and Applications Group. Computer program Review Monitor for the hydrologic engineering discipline. Office, Chief of Engineers.

been no (known) discrepancies of a serious nature occurring in project design or operation, as a result of faulty programs or their misuse, is due to the inherent trait of engineers to do the job right, even in the absence of specific guidance. The seemingly lack of error has been due in part to program usage being limited to the authors, and to their nearby associates who are given first hand assistance in using the programs. This limited use by others is changing . . . rapidly.

Those of you who are intimately familiar with program development are well aware of the overpowering desire, as well as the need, to render a program completely error free. It is like California or bust. However, many of us are reluctant to adequately document our programs for use by others, myself being no exception. Regardless of the reasons for avoiding documentation, e.g., time and effort, they all seem inexcusable especially if we are to establish a successful computer program sharing system on a Corps-wide basis. The engineering profession will always depend very strongly upon integrity and trust of engineers at the computational level, but there is more than this to consider. Even the best engineers have been known to make mistakes occasionally. Most of the reasons that constitute the need for review of engineering methods and techniques, and their application in design memoranda and other reports, are equally valid for requiring the review of engineering computer programs.

In addition to the library mentioned earlier, which will distribute specially prepared programs on a Corps-wide basis, The Hydrologic Engineering Center (HEC) has been offering programs to the field offices for about six years, and they learned very soon the importance of program documentation. To supplement their efforts to accomplish adequate documentation, instruction during training courses is often given to explain and discuss the use of certain of their programs. Hopefully, arrangements can be made in the near future to couple a convenient and expert assistance with the ECPL similar to that of the HEC, although such plans exist only in the minds of a few engineers at present. I dwell upon "assistance in the use of programs" to emphasize the additional effort that must be made to standardize and document programs for the benefit of the user. Program authors will be encouraged to avail themselves for consultation by telephone, but I envision supervisory problems and seriously question the effectiveness of such an arrangement. Instruction by telephone can be valuable, but it is very limited. The Corps needs a small group or groups of engineers organized for the express purpose of serving other disciplines in a manner comparable to the service provided hydrologic engineering by the HEC.

Several of you here at the seminar have expressed strong opinions spontaneously, and within your papers, regarding the need for adequate documentation. My contention is that program development and review

go hand in hand, and without specific guidance for the latter, adequate documentation will doubtless be realized. It can hardly be questioned that requirements for program review are urgently needed to assure conformance to coding standards and documentation procedures.

Other difficulties arise when trying to establish the "scope or extent" of review within a particular office, as well as the difference in review procedures to be performed at the various organizational levels. The following attachment to this paper is an attempt to resolve these and other associated problems. I am going to present a proposed directive to you as a "strawdummy," i.e., for your evaluation and comment. Other considerations while formulating the directive were: (1) instilling confidence in the mind of the program user; (2) categorization of programs to control areal distribution; (3) poor performance of existing approved programs, and what to do about them; (4) keeping programs up to date; (5) temporary waiver of certain requirements for development to permit a rapid build-up of programs in the ECPL (not recommended); (6) difficulty in selecting one or a few programs from among several programs which calculate essentially the same thing; (7) the ability of HEC and WES to perform reviews; (8) the varying ability of field offices and OCE to perform meaningful reviews, including differing capabilities of the various engineering disciplines within any one office; and finally, (9) assurance of satisfactory project design. After I have read the proposed plan for reviewing engineering computer programs, you will be given what may be your first opportunity to criticize a proposed directive.

DRAFT

**Requirements for
Review of Engineering Computer Programs**

1. Purpose. The purpose of this directive is to establish guidance and requirements for the review of computer programs used in the planning, design, construction and operation of Corps of Engineers projects. This directive supplements the information contained in ER 1110-1-10 pertaining to computer program review.
2. Scope. Guidance and requirements are given for review at appropriate organizational levels for each of the three categories of digital computer programs defined in ER 1110-1-10, reference 4a below. Coordinating activities of computer program Review Monitors in the Office, Chief of Engineers are also outlined herein. Reference 4e below lists the names of Review Monitors for the various engineering disciplines.
3. Applicability. This directive is applicable to each engineering discipline within the Corps of Engineers. Normal engineering command channels are responsible for enforcing the requirements for review that are outlined herein. A directive similar to this is planned for distribution within OCE and to appropriate field offices to aid the development, review and use of computer programs.
4. References:
 - a. ER 1110-1-10, Development, Review and Use of Computer Programs, 30 June 1970.

- b. ER 1110-2-40, Engineer Computer Programs Library, 21 August 1970.
- c. ETL 1110-1-45, Engineering Computer Programs Library, Standards and Documentation, 9 February 1971.
- d. OM 1110-2-1, Standing Operating Procedure for Review of Design Memorandums, 18 April 1969, and references therein.
- e. EC 18-1-32 Planning Data--Engineer Information and Data Systems Office, 15 January 1971.
- f. ER 10-1-2, Par. 2, Decentralization, 8 August 1963.
- g. EC 18-1-29, Release of Computer Programs and other Documentations, 6 July 1970.

5. Basis for Review. The need for review of engineering computer programs used in the Corps of Engineers is no less desirable than prevailing requirements for review of engineering methods and practices associated with design memorandums and other reports (ref. 4d). In some respects the need is greater, primarily because of newly developed and more complex methods that only lend themselves to computerized solution. Assurance of the adequacy of design is the objective in either case, which may be increased or decreased from the standpoint of the reviewer in comparison to manual computations. Other reasons for review are to enhance user reliance of programs in the Engineering Computer Programs Library (ECPL) at the Waterways Experiment Station (ref. 4b), and to control duplication of program development, insofar as practicable. Conformance to the principles and guidance contained herein, at each organizational level, will aid the evaluation of programs by reviewing engineers and expedite their approval.

6. Categories of Computer Programs. All computer programs used within the Corps have been grouped into three categories (ref. 4a). The scope of requirements for review are different for each category and for various organizational levels within the Corps, as explained throughout the remainder of this directive.

a. Category A. These programs are approved for Corps-wide use and are included in the Engineer Computer Program Library at the Waterways Experiment Station. Conformance to coding standards and documentation procedures established by the Engineer Computer Concepts and Applications Groups (ECCAG) and outlined in reference 4c, is required.

b. Category B. Category B programs are approved for inter-Division of independent office use, such as SWD, NPD, CRREL, CERC and other installations. These programs are also included in the library at WES, and must conform to standards and documentation requirements of the ECCAG.

c. Category C. These programs are developed for originating office use only. Coding standards and documentation criterion of the ECCAG are not required by OCE, and they are not included in the library at WES. However, review and approval is required for the more important of these programs, as explained below.

7. Levels of Review. The extent or degree of review to which computer programs will be subjected has been divided into three levels; namely; basic extensive and moderate reviews. The levels are arranged according to the "organizational levels" of reviewing offices within the Corps, and generally represent the "extent of review" required at each level.

Extensive or major review requirements are assigned to the Divisions and independent offices, which is in keeping with the current trend toward decentralization (ref. 4f). These associations are explained in the following sub-paragraphs, and exceptions are covered in later paragraphs of the directive. Review beyond the originating office is considered necessary to satisfactorily evaluate and approve all Category A and B programs, and the more important Category C programs. Programs that are used for significant aspects of Corps activities, regardless of category, must be referenced in design memorandums and other reports submitted for review (ref. 4a). Category C programs used in this manner are referred to herein as the "more important" of the category to identify them for review. Category C programs that may be exempt from review outside the originating office are those used in preliminary planning, utility type programs and all other programs of relatively insignificant importance, insofar as the design and regulation of Corps projects are concerned. Further differentiation of the relative importance of Category C programs, and likewise the extent of their review, is left to the discretion of the field offices.

a. Level 1 - Basic review. A basic or primary review is required by the originating office for all programs, regardless of category. This is a thorough initial review associated with program development and initial application.

b. Level 2 - Extensive review. An extensive or detailed review is required by Divisions and independent offices for Category A and B

programs, and the more important Category C programs. Extensive reviews of other programs may be performed at any organizational level if considered appropriate. This is a major review in depth, thus the most extensive of the three levels.

c. Level 3 - Moderate review. A moderate or limited review is required by OCE for all Category A and B programs, and the more important Category C programs. When appropriate, review of Category C programs by Divisions and independent offices may be limited to this level. This is the least extensive type of review, which may be very limited or cursory if appropriate.

8. Constituent Parts and Aspects of Review. Computer programs are sub-divided into four sections in ER 1110-1-10 for convenience of development, review and application. Briefly, these sections consist of: Section I - program abstract; Section II - methods of solution; Section III - file documentation; and Section IV - software. Detailed requirements for the constituent parts of programs are given in reference 4c in terms of standards and documentation procedures for those programs to be included in the library at WES. Other significant aspects of review follow:

a. Program testing. The very nature of program development and initial application usually includes extensive testing, primarily with regard to error-free coding and solution precision (re, level 1). However, for reasons given in paragraph 5, further evaluation of testing should be performed at higher levels on these and other aspects of

programs. Test examples submitted with the program description should be limited, but selective in terms of more common applications of the program. Complex programs offering several input options should undergo appropriate tests by the originating office, who should be prepared to furnish adequate evidence, upon request from higher authority, of satisfactory performance of the program for any combination of permissible input options. A concise summary of program testing for major options should be documented in the program write-up. New programs that do not include satisfactory test examples or cannot be substantiated by further testing, will not be approved for use in any manner until the errors are corrected, or the unsatisfactory options are eliminated. Programs discovered to perform unsatisfactorily, even though previously approved, will also be disapproved for use (at least in the manner noted unsuitable) and subjected to possible deletion from the library at WES if contained therein. Normally, Category C programs will not require as extensive testing beyond the originating office as Category A and B programs. Comparatively, the greatest amount of "testing" is required by the originating office, even though the most extensive "overall review" is required by the Divisions and independent offices, and the extent of additional testing is left to the discretion of the reviewing offices (re, levels 2 and 3).

b. Categorization. Originating offices should consider appropriate categorization of each program, and develop the programs accordingly. Encouragement is given to the highest possible category, insofar as

time and manpower permit. Assignment of programs to Category C will be performed by the originating office, and further consideration toward categorization should be given at the Division or independent office level, especially in regard to Category B, and establishment of same. Final categorization of programs for Corps-wide use will be established by the Office, Chief of Engineers, with due consideration given to recommendations of the field offices.

9. Review by Originating Office. Requirements for the basic or primary (level 1) review of computer programs are given in the sub-paragraphs below. The bulk of this review is closely associated with program development and application, and emphasis should be placed upon error-free coding and solution precision. In addition to the initial review, this office has major responsibility for application assistance and updating the program. Requirements for review follow:

- a. Develop Category A and B programs to meet standards and documentation requirements given in reference 4a.
- b. Develop Category C programs to meet standards and documentation requirements adopted by the originating office.
- c. Thoroughly test all programs for the more important and popular options of application.
- d. Assign programs to Category C, and recommend A and B categorization, as appropriate.
- e. Submit Category A and B, and the more important Category C programs to higher authority for review and approval.

10. Review by Divisions and Independent Offices. Requirements for review by the Divisions and independent offices are more comprehensive than requirements for any other organizational level, and will usually be of the level 2 type. The extent of review considered appropriate for Category C programs is left to the discretion of these offices in accordance with the guidance given in paragraph 7 above. Requirements for review follow:

a. Require compliance of Category A and B programs with the standards and documentation requirements given in reference 4c.

b. Perform a detailed review of the more important Category C programs that are used for project development or regulation, and referenced in design memorandums and other reports submitted for review. Perform a moderate review of other Category C programs. Reference 4c may be used as a guide for reviewing Category C programs.

c. Evaluate tests performed by originating office and perform additional testing, or request from originating office, if necessary to assure satisfactory performance of the program for the more important and popular options of program application.

d. Assign programs to Category B and C, and recommend Category A, as appropriate.

e. Submit Category A and B, and the more important Category C programs to OCE for review and approval.

f. Perform only a cursory review of those programs pertaining to hydraulic and hydrologic engineering, regardless of category, and

forward to OCE. These programs will usually be submitted to the HEC and/or WES for detailed review, as appropriate, which will limit the workload for review at Division and independent offices.

11. Review by Office, Chief of Engineers. The review by OCE will usually be of a limited (level 3) nature, with emphasis upon methods of solution and documentation. However, an extensive (level 2) review will be performed if considered appropriate, which may involve the utilization by OCE of select personnel in the field offices. Engineering specialists in OCE that are knowledgeable in computer applications have been designated computer program Review Monitors (ref. 4e), to serve in a coordinating capacity for applications assistance within their respective engineering disciplines, in addition to the review of programs, for engineers in the field offices. The Review Monitors should coordinate with the library (ECPL) at WES for the build-up and maintenance of programs in their respective engineering disciplines, and should become generally knowledgeable of these programs. The Review Monitors serve in a liaison capacity between potential program users and the library, and between users and authors of programs in response to requests for assistance. Aspects of a level 3 review follow:

a. Perform a moderate review of Category A and B programs for conformance with the standards and documentation requirements given in reference 4c.

b. Perform a moderate review of the more important Category C programs used for project development or regulation referenced in design memorandums and other reports submitted for review.

c. Evaluate tests performed at previous review levels and perform additional testing, or request from originating office, if necessary to assure satisfactory performance of the more important and popular options of program application.

d. Transmit hydrologic and hydraulic engineering programs to HEC and/or WES, as appropriate, for extensive review. Perform a very limited review of these programs upon their return.

e. Comply with reference 4g regarding requests for Corps computer programs by other agencies.

f. Perform a moderate review of programs developed by the HEC and WES.

g. Approve or disapprove programs and categorize as A or B, as appropriate.

REQUIREMENTS FOR
REVIEW OF ENGINEERING COMPUTER PROGRAMS

Discussion

Question, Mr. Beard: Would it be helpful to make the review categories more definitive - such as thorough testing by originating office, technical review by Division office and functional and policy review by OCE?

Reply, Mr. Sharp: The descriptive phrases you suggest are very representative of the "type" of review intended for each of the three organizational levels. Coupling the terms you suggest with those already used to represent the "extent" of review will enhance understanding of the directive:

Level 1 - Originating office: basic or initial review, to include thorough testing.

Level 2 - Division or independent office: extensive review, emphasis upon technical aspects.

Level 3 - Office, Chief of Engineers: moderate review, primarily regarding policy.

Retention of the other terms (basic, extensive & moderate) is needed if we are to comply with the current trend of delegating more responsibility to the Division offices.

Comment, Mr. Bennion: I feel that the review accomplished at the Division should generally be of the technical adequacy nature - not a review for accuracy of programming, etc. This will leave the Division free for other review functions that they should be performing.

Reply, Mr. Sharp: In the event you are referring to a detailed review of each "programming" statement and each coding routine, I agree with you, and the proposed directive would not require the Division offices to do this. However, there are those who insist that review at intermediate steps in computational procedures, even at the OCE level, is necessary for a review to be at all meaningful. If use of the word "programming" is intended to represent computational procedures rather than coding, who do you propose should perform the review for technical "accuracy"? Division offices are required

to review all other applications of engineering techniques and methods of solution for their "accuracy", as well as for "adequacy". Limiting the "extent" of review to no more than is required to assure the "accuracy" needed is the important thing.

Question, Mr. Fredrich: What will happen when the review assignment falls upon an organization or individual without the technical competence to perform the review?

Reply, Mr. Sharp: I think we would agree that this problem cannot exist in an office that originates a program. Review requirements for the Division offices (Level 2) and OCE (Level 1), as proposed, are flexible for this very reason. In cases where Division offices do not have the expertise, they should inform OCE of this fact and "forward" programs rather than "recommend" them for approval. OCE will either, (1) perform an extensive review (not very likely); (2) utilize the better engineers in field offices for review of these programs; or possibly (3) return them to the Division office when a cursory or moderate review reveals they are unsatisfactory.

Question, Mr. Peters: Is a mechanism available for requesting review of computer programs developed outside the Corps?

Reply, Mr. Sharp: Not to my knowledge.

Comment, Mr. Beard: Perhaps there is some question as to whether OCE would be wise to imply in their approval of a program that work using that program would be automatically approved insofar as the program use is concerned.

Reply, Mr. Sharp: This is a most important point, and I hope that I have not implied this. To be sure, a qualifying statement will be added to the proposed directive in this regard.

SEMINAR ON COMPUTER APPLICATIONS

SUMMARY AND CONCLUSIONS

by

Bill S. Eichert⁽¹⁾

The participants of this seminar represent a wide range of experience in both computer use and hydrologic engineering, and have diversified views according to diversified experiences in the different offices they represent. The Corps of Engineers' participants are from District offices, Division offices, Office of the Chief of Engineers, and The Hydrologic Engineering Center. The non-Corps participants are from the US Geological Survey, the Tennessee Valley Authority, and the Bureau of Reclamation. These men range in experience in computer applications from those who have had supervisory experience without familiarity with computers to those who are experts in computer hardware and software.

The papers of this seminar discussed the use of small computer programs (both generalized and specialized), comprehensive generalized computer programs and large specialized computer programs. The papers also cover such items as programming, real-time computer applications, program modification problems, computer documentation needs, management of computer use, hardware and software availability, conversational programming techniques, mass data analysis, and requirements for review and certification of computer programs.

Because of the wide use of computers in the field of hydrology and the limited number of papers given, many areas of computer use in hydrology were not covered in this seminar, and several important areas were only mentioned in passing. The effectiveness of The Hydrologic Engineering Center's efforts in providing generalized computer programs was discussed in general terms, but a realistic appraisal of the adequacy of the HEC work in documentation, assistance, and general program capabilities was not made. The advantages and difficulties encountered in inter-office sharing of computer programs were discussed on several occasions.

The papers show the great progress that has been made during the last ten years by the Corps of Engineers and others in the use of computers in hydrology. Very few Corps offices were using computers ten years ago, and they used them in a few simple applications. Now all Corps District offices use computers on a wide range of problems, and

(1) Chief, Training & Methods Branch, The Hydrologic Engineering Center, US Army Corps of Engineers, 609 Second Street, Davis, California.

many have medium-speed computers. Many others have terminals and are sharing the use of high-speed computers with other offices. The progress and experience by the New England Division office in the automatic collection of hydrologic data, as described in paper 11, is an outstanding example of new applications.

The necessity for using computers to keep pace with the number of possible alternatives for each planning or operation decision was emphasized in several papers. The increased complexity of each individual problem is magnified with each added dimension because of the interaction among problems. For example the need and capability to examine water quality interactions has greatly expanded the planning and design problems of previous generations. Without the computer and new mathematical techniques, the additional studies required by these complexities would have been impractical. The Corps' development of generalized computer programs for specific engineering applications has made it possible for the computer to be effectively utilized on large and small jobs in nearly all parts of the country. Several good examples of programs of this nature were given in papers 1, 2, and 3.

The concept of a living computer program for the large generalized computer packages was also suggested in paper 1. The basic concept is that a computer program must grow or renew itself as new problems develop and as new techniques become available.

Several of the papers presented flexible comprehensive computer programs in certain areas of hydraulics and hydrology. Paper 4 presented a comprehensive program for interior drainage computations which will handle various combinations of river stage, gravity drain flow and pumping, over the historical period of daily flows, in sufficient detail to provide the necessary information for a detailed economic analysis.

Paper 6 describes one of the most thoroughly tested computer programs in existence, and one of the few programs available for unsteady flow computation. The TVA program will accurately describe the movement of water in a reservoir or river as it responds to the multipurpose operation of the facilities bounding the reservoir or river. The water release operation may be as sudden as the near instantaneous come-on and shut down of the turbines during power peaking or as gradual as the passage of floodwaters through the control structures.

The Bureau of Reclamation's progress in developing a comprehensive model for system analysis was presented in paper number 8. Their model is designed to perform system analysis studies for multipurpose reservoirs including irrigation, power, flood control, and water quality augmentation. The program also makes use of both ground water and surface water resources in automatically determining the most economical plan by using a technique similar to dynamic programming.

The use of a conversationally oriented real-time programming system, as contrasted to running an entire job in batch mode, received a great deal of discussion. The difficulty of checking intermediate answers for reasonableness in a huge run made in the batch mode was pointed out. This difficulty can be overcome by temporarily separating the large job into several jobs until the adequacy of the input data is determined; then the final processing of the entire job can be done. The value of using the conversationally-oriented system for training purposes and for jobs requiring small volumes of input was also discussed.

Paper 12 on power of a general storage data array presented a new idea to most of the seminar participants. The method provides for more efficient use of the computer core storage used for dimensioned variables. All dimensioned variables could appear in one common array and there would be no limits on individual variables as long as the total items in all variables does not exceed the dimension statement of the general array. This technique is a substitute for dynamic dimensioning, which is available on only a few computers.

The proliferation of computer programs and the extensive application of computer programs in hydrologic studies have created unique problems for persons who are responsible for establishing the validity of computer-based studies. The degree of confidence that can be placed in such studies depends on the degree of confidence that can be placed in the computer programs that were used in the studies. In paper 16 it is recommended that programs be categorized according to the extent of testing and review that the programs have been given, and requirements for review of computer programs are proposed.

Several of the discussions made reference to the need for adequate computer program documentation, which led to the "conclusions" stated in this regard.

Conclusions

1. The Corps of Engineers should continue its efforts in eliminating unnecessary duplication in the District offices in developing and maintaining large computer programs. The number of generalized computer programs and solutions approved for use on a Corps wide basis for a particular engineering problem should be limited to no more than two or three. Consideration should be given to modifying these programs when it is necessary to perform special related computations, rather than develop new programs. Special-purpose programs and programs that require only a moderate development effort should be written in each District office, since the time to train people to properly use these programs could exceed the development costs.

2. Computer program documentation should be commensurate with its use. A minimum of documentation would be required for the special purpose program that is used only once; considerably more documentation would be required if the program is to be used frequently. The generalized computer program should be well documented and should contain sufficient information for an engineer to use the computer program correctly.

3. It is recognized that the best documentation of the generalized computer programs cannot fully explain the effective use of all of the program capabilities to every user. Therefore, special training and/or assistance should be available from the developing office to help new users become acquainted with the more complex programs. Formal or informal training from a few days to 2 weeks may be required to effectively avoid the apparent use of the black box approach. A reasonable amount of time should be given by the supervisor to the engineer to learn how to use these large programs. Reviewing source deck listings, studying flow charts, and running sample data based on hand computations are all good ways to become familiar with the new program.

4. The Corps of Engineers should provide each Corps office with modern computer facilities and service that include adequate memory, speed, and provisions for rapid turn-around (5-60 minutes). Where adequate computer facilities are not available to use the latest generalized computer programs developed in the Corps, administrative policies should encourage the renting of adequate computer facilities from computer service organizations. The use of in-house computers should be mandatory only for applications where sufficient computer memory, speed, and turn-around are available. The common practice of rewriting and stripping large programs to fit on smaller computers should be discouraged where adequate computer facilities can be rented. The use of rented computer time should also be approved if the in-house computer cannot provide turn-around time of 1 hour or less when required.

5. Administrative policies concerned with obtaining computer hardware should be streamlined to reduce the time required to obtain new equipment.

6. Computer hardware selected for installation in Corps District offices should have available adequately tested software that make a computer terminal effective when used in conjunction with a large computer in the Division office. The capability of the system to recompile a large program based on a few changes without rereading the entire source deck is a necessary part of any good system. The present software for the GE-400 series computers being installed in Corps offices should be modified to provide this capability.

7. The Corps of Engineers should devote more effort to developing generalized programs for short-interval routings which operate reservoir systems during flood periods. These programs would include forecasting reservoir inflows and local runoff and the determination of reservoir releases all on a real time basis. A separate program with similar capabilities should also be developed for simulating reservoir system studies as a planning tool.

8. Steps should be taken immediately to identify needs and develop specifications for hardware and software to meet the requirements of increasingly complex real-time operation of large water resource systems. The operation of existing reservoir systems is already taxing the capability of available Corps computers, and the needs are increasing rapidly. The consideration of operation constraints which are imposed by environmental and social objectives and the increased emphasis on optimal operation plans will soon result in computational requirements that cannot be accommodated with the equipment currently available to the Corps offices.