

ID-A052 608

HUGHES AIRCRAFT CO FULLERTON CALIF
NEAR FIELD ANTENNA MEASUREMENT SYSTEM. (U)
JAN 78 A E HOLLEY
FR-78-14-338A

F/G 14/2

UNCLASSIFIED

DAAB07-77-C-0587
NL

| of |

AD
A052 608



END
DATE
FILMED
5-78
DDC

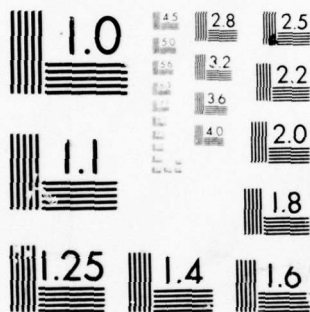

MICROCOPY RESOLUTION TEST CHART
NATIONAL BUREAU OF STANDARDS-1963-A

AD NO. ~~1~~
DDC FILE COPY

AD A 052608

12
ap

FIRST QUARTERLY PROGRESS REPORT
NEAR FIELD ANTENNA MEASUREMENT SYSTEM
29 AUGUST 1977 TO 30 NOVEMBER 1977
CONTRACT DAAB07-77-C-0587

Placed by: U.S. Army Electronics Command
P. and P. Directorate W15P7R
Fort Monmouth, New Jersey 07703

Hughes Aircraft Company
1901 W. Malvern
Fullerton, California 92634

Approved for public release; distribution unlimited.

"The findings in this report are not to be construed as an official Department of the Army position unless so designated by other authorized documents."

"Destroy this report when it is no longer needed. Do not return it to the originator."

"This project has been accomplished as part of the U.S. Army (Manufacturing and Technology) program, which has as its objective the timely establishment of manufacturing processes, techniques or equipment to insure the efficient production of current or future defense programs."

FR 78-14-338A

DDC
RECEIVED
APR 13 1978
D

FIRST QUARTERLY PROGRESS REPORT
NEAR FIELD ANTENNA MEASUREMENT SYSTEM
29 AUGUST 1977 TO 30 NOVEMBER 1977
CONTRACT DAAB07-77-C-0587

Placed by: U.S. Army Electronics Command
P. and P. Directorate W15P7R
Fort Monmouth, New Jersey 07703

Hughes Aircraft Company
1901 W. Malvern
Fullerton, California 92634

Approved for public release; distribution unlimited.

"The findings in this report are not to be construed as an official Department of the Army position unless so designated by other authorized documents."

"Destroy this report when it is no longer needed. Do not return it to the originator."

"This project has been accomplished as part of the U.S. Army (Manufacturing and Technology) program, which has as its objective the timely establishment of manufacturing processes, techniques or equipment to insure the efficient production of current or future defense programs."

ACCESSION for		
WTS	White Section	<input checked="" type="checkbox"/>
DD	Buff Section	<input type="checkbox"/>
UNANNOUNCED		<input type="checkbox"/>
JUSTIFICATION.....		
BY.....		
DISTRIBUTION/AVAILABILITY CODES		
Dist.	AVAIL. and/or SPECIAL	
A		

FR 78-14-338A

DDC
RECEIVED
APR 13 1978
D

6

NEAR FIELD ANTENNA
MEASUREMENT SYSTEM.

9

FIRST QUARTERLY REPORT. no. 1
29 AUG ~~1977~~ TO 30 NOVEMBER 1977

The objective of this program is the development of a complete, self-contained system which will automatically probe the near field amplitude and phase of an antenna aperture and compute and display far field antenna patterns and related data.

15

Contract DAAB07-77-C-0587

10

Prepared by A. E. Holley

11 11 Jan 78

Approved for public release; distribution unlimited.

12 27p.

14

FR-78-14-338A

1473
172 350 -

ABSTRACT

This report describes the first three months activity in the development of a fully self-contained automated near field antenna measurement facility. A description of the system is included. The primary efforts have involved purchasing of long lead hardware and equipment, mechanical design of the positioner structure, and outlining of software requirements.

TABLE OF CONTENTS

	Page
PURPOSE	1
NARRATIVE	2
System Description.....	2
Program Organization	5
Status of Individual Functional Areas	6
CONCLUSIONS	9
PROGRAM FOR THE NEXT QUARTER.....	9
IDENTIFICATION OF TECHNICIANS	11
DISTRIBUTION LIST	23

LIST OF ILLUSTRATIONS

Figure 1 – Positioner Structure	3
Figure 2 – System Interconnections	7/8
Figure 3 – 3D Plot Example	10
Attachment – Software Functional Design Specification	17

PURPOSE

The measurement of antenna characteristics is a significant cost item in the development, manufacturing, and field use of many radar and communication systems. Such costs are particularly high for phased array radar systems where a large amount of information, such as beam position data, is required on each individual antenna in order to provide system calibrations.

The conventional approach to such requirements involves transporting the antennas and beam steering control equipment to a high performance outdoor pattern range, often at a considerable distance from the manufacturing site. Even if the pattern range is automated so that data acquisition is computer controlled, a relatively long test program is required to properly evaluate typical phased arrays. If problems arise, far field pattern measurements provide little insight into the difficulty--a single miswired phase shifter or an open connection in a complex array may be almost impossible to diagnose without dismantling the system.

In recent years a measurement technique called near field probing has been developed to the point where it can provide an effective alternate to the far field range. The National Bureau of Standards, Boulder, Colorado, and the Georgia Institute of Technology, Atlanta, Georgia, have pioneered in the development of the hardware and computational techniques necessary to make this approach practical. Both organizations have built and demonstrated systems which provide accurate measurements on typical array antennas.

The near field technique involves the sampling of the vector RF field on a periodic grid near the antenna radiating aperture. These data are converted to a far field pattern by a mathematical algorithm equivalent to the actual creation of the far field pattern in space from the field distribution. Although the sampling must be periodic, and approximately at half wavelength intervals, an absolute position reference to the antenna aperture is not required. This feature makes the technique extremely cost effective for measurements of phased arrays since many beam positions can be interlaced during a single scan of the near field probe. Fast RF switching may also be used to allow sum and difference or multiple beam antenna ports to be properly sampled during a single scan.

This program will develop the hardware and software necessary to provide a near field measurement system capable of meeting the requirements for measurements of planar array antennas such as the AN/TPQ-36 and AN/TPQ-37.

NARRATIVE

System Description

The system being developed consists of a 2 axis XY positioner, an antenna mounting structure, a signal source and phase amplitude detector, and a computer, display and control system. The system will be entirely self sufficient with only special control devices for the antenna under test required to perform a full measurement of all pertinent antenna parameters.

The basic design of the positioner mechanism has a great deal of similarity to the very successful NBS facility except for modification necessary to make the equipment relocatable and to provide a more suitable antenna mounting arrangement.

The positioner scans in a vertical plane and is capable of traversing 13 feet in the X (horizontal) direction and 15 feet in the Y (vertical) direction. Simple scaling of the design could be used to obtain different area coverage. Lateral displacement of the probe with respect to the antenna under test (Z direction) is accomplished by movement of the antenna mount. The artist's sketch in Figure 1 shows the positioner mechanism.

Accurate position measurements in the X and Y direction will be made by a Hewlett-Packard laser interferometer measuring system. The laser measuring system is more than adequate to provide the specified probe position resolution of .005 in. Each axis will be monitored independently by the software operating system to allow on-line determination of the probe location while the probe is traveling across the antenna aperture. A single laser transducer will be used as the coherent light source, and the output beam split to provide a beam for each axis. Each beam will be measured using its own interferometer and receiver, with the two receiver outputs being fed into an interface unit for translation to a binary value that can be read by the computer.

The probe used to sample the radiated field mounts in a simple, manually adjusted fixture on the vertical carriage of the positioner. The fixture allows the probe to be rotated about a Z-axis for polarization selection with indexing provided to insure repeatability. The accuracy obtained in the computation of the far field patterns is strongly dependent on the accuracy of the probe characterization. For linearly polarized antennas, the probe should be linearly polarized. To avoid ambiguities in the computed pattern, it is necessary that the probe pattern not have any nulls in the region of interest and linearly polarized, open-ended waveguide elements are nearly optimum probes for this system. A complete data set will be measured on each probe in an anechoic chamber. In this calibration measurement, the probe will be as close as possible to the condition it will be used in the near field measurement. Absorber will be placed around the back of the probe so the RF characteristics measured in the anechoic chamber will be the same as they are in the near field test.

An antenna mounting fixture will be provided which, while designed primarily to support the AN/TPQ-36 and AN/TPQ-37 antennas, can readily be used with other antennas. This antenna mount has the capability of linear travel in the lateral (Z) direction and rotation about the Y (vertical) axis. The lateral motion is provided

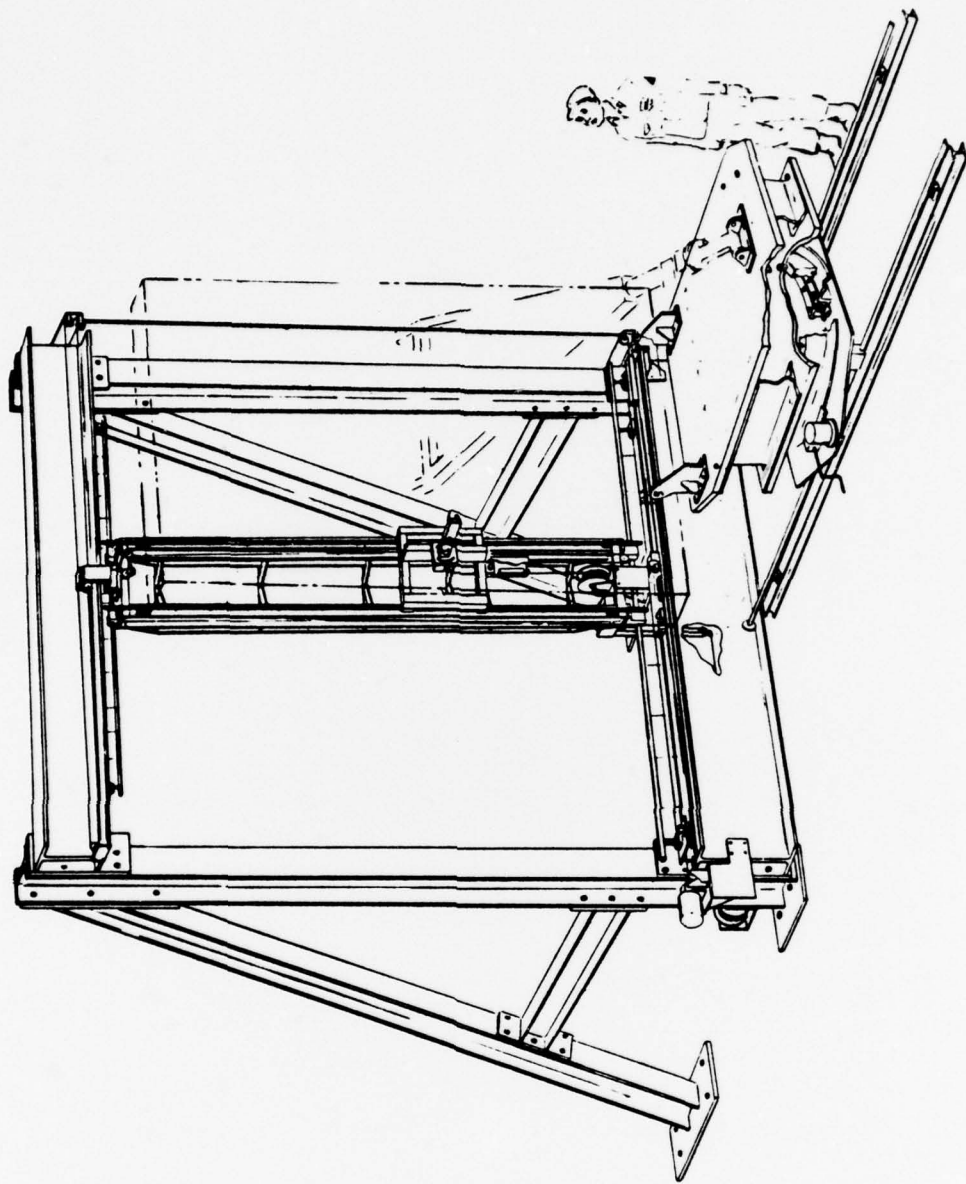
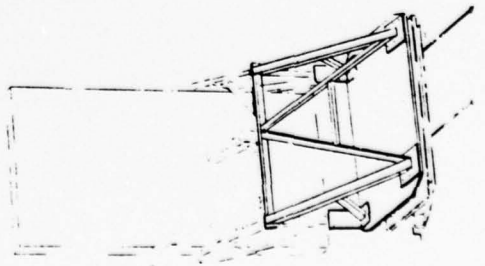

Figure 1. Positioner Mechanism with Antenna Mount.



by placing the antenna mount on ball bushing pillow blocks riding on hardened and ground stainless steel shafts. The lateral six feet of travel is sufficient to allow rotation of the mount and convenient installation or removal of the AN/TPQ-36 and AN/TPQ-37 antennas without interference with the probe positioning structure. The rotation about the Y-axis is provided by a large roller bearing. Locking mechanisms are provided to prohibit lateral and rotational movement while measurements are being taken.

A frequency synthesizer (Hewlett-Packard 8672A) and network analyzer (Hewlett-Packard 8410) form the source and phase amplitude detector for the system. These specific units make it possible to realize measurement rates consistent with the concept of multiplexing and obtaining a full set of antenna data in a single scan, while meeting the stability and accuracy required to meet the system performance objectives. The computer controls the synthesizer through an IEEE 488 Buss interface and high performance analog to digital converters are used to translate the phase and amplitude data from the network analyzer into the computer.

A Hewlett-Packard 1000 computer system has been chosen for this application because of its sophisticated real-time executive operating system, extensive instrument interface capability, large and fast memory, complete subsystem software, microprogrammability, and high-speed input/output. This computer system forms the major element for controlling the collection and processing of near-field data. All normal operations will be performed under the control of the real-time executive and subsystem software.

The 50 megabyte on-line disc provides sufficient data storage for both the near-field probe data and software used in data collection and analysis. The disc also provides a media for interactive software modification and program generation. A magnetic tape drive allows the system user the capability to store collected data as well as software sources for off-line use, transfer to other computer systems, or for archives. The HP21MX, E series, computer used in this system provides, in addition to a fast processing speed and high-speed main memory, a considerable amount of main memory to handle the special processing required for the efficient three-dimensional or contour plot generation. To further improve operating speed, special microcoded instructions may be included to handle extended precision numbers and subroutine transfers.

There are two devices used for graphic display--a Hewlett-Packard CRT terminal display, and a Versatec Model 1200 electrostatic printing/plotting device. The CRT has 1024 x 1024 addressable points; the hard copy unit provides 200 dots/inch, across the 11-inch page and may generate as long a plot as required. These graphic peripherals have dual functions since they are also used as the system console and line printer, respectively.

The software to support these devices includes a library of subroutines to generate simple plots with axes, notation, grids and automatic scaling on both the CRT terminal and hard copy plotter. More sophisticated plots such as contour plots and three-dimensional plots are generated directly on the electrostatic plotter.

Software to be used with the near field measurement system can be divided into four general categories:

- Control and measurement
- Analysis
- Display
- Standard subsystems

The control and measurement software involves most of the programming written specifically for the system. The analysis software primarily involves a number of FORTRAN subroutines which have already been developed by NBS and Georgia Tech and which have been converted to operate on the Hughes HP3000 computer which is a 16-bit machine like the selected minicomputer. Since a cross compiler is available on the 3000 for the 21MX, much of the preliminary effort and debug will be performed on the larger machine. Display software mainly involves standard products such as HP PLOT and VERSAPLOT which are currently in use. Standard software provided with the selected minicomputer system is among the most complete and capable of any currently available for a minicomputer including many functions normally not associated with minicomputers. The real-time operating system is the most appropriate computer operating software available for automated test applications.

The operation of the X-Y positioner including the laser interferometer, selection of the RF source frequency, and recording and storing probe data will be controlled by software subroutines. The control programming will operate in two basic modes, with all operator dialog being performed through a conversational command sequence. One mode will normally be used for making a measurement on either an AN/TPQ-36 or AN/TPQ-37 antenna using a predetermined set of frequencies and beam positions. In this mode, all parameters, such as positioner speed, measurement intervals, data file allocation, and number of antenna inputs, will already be known, and the measurement will begin on operator command.

The second mode of program execution will allow an operator to specify the various characteristics of a measurement for general applications. Parameters, such as measurement frequencies, beam positions, and number of antenna input ports will be input through the console keyboard using an English language dialog with the operator. The program will then determine measurement locations either by calculation or as requested by the operator, determine positioner speed to achieve measurement reliability, etc. and begin the measurement. Controls will be available to the operator to select a specific frequency and beam position and perform spot check measurements or to set up a complete measurement sequence which could be stored for production use.

Measurement intervals will normally be determined by the set of measurement frequencies. Each beam position and antenna input port will be measured at half-wavelength intervals for every frequency. A table of locations will be constructed in the program that will be compared to the laser interferometer location data. At each point of coincidence during a vertical scan of the positioner a measurement of phase and amplitude will be initiated and a frequency, beam position or port parameter changed to be ready for the next coincidence. At the end of the pass, the vertical drive will be set back to the start position, the horizontal drive will be moved approximately one-half wavelength, and another vertical pass started. Optimum positioner speed will be determined from the measurement pattern to allow data to be taken in the shortest possible time while maintaining data reliability.

Program Organization

The entire development task has been divided into separate functional areas generally associated with specific individual responsibilities. These are:

- Computer Hardware
- Microwave Equipment
- Laser System
- Positioner Structure

- Positioner Drive and Control Equipment
- Antenna Mount Structure
- System Housing
- Interface and Cabling
- Software Design
- Control and Data Collection Programming
- Analysis Programming
- Display Programming
- System Alignment Procedures
- Test and Evaluation Procedures

In this and subsequent quarterly reports each of these areas will be reported on as to status including problems and results for each individual area.

Status of Individual Functional Areas

Computer Hardware--Orders have been placed for all of the basic computer system equipment including all standard interface cards and the electrostatic plotter. The basic system, a Hewlett-Packard 1000 is expected to be delivered and set up in early January 1978. A member of the program staff will attend a two week training session in mid January to become fully familiar with the System 1000 hardware and Real-Time Executive software. No problems have been encountered associated with this portion of the system.

Microwave Equipment--The major microwave equipment items, the signal source, the network analyzer, and the preamplifiers have been ordered and will be delivered during the first quarter of 1978. No problems are anticipated in connection with these items and an internal Hughes test facility which uses these items in an automated control system is nearing completion. This test facility will provide considerable experience in using this equipment prior to use in the near field facility.

Laser System--The equipment required for the laser interferometer position measurement system has been ordered and delivery is expected in mid December 1977. Alternative approaches to using the laser data for automatic control of the positioner are being studied. No hardware difficulties are expected in this area and a mockup of the laser system will be built to check its operation and interface before installation on the actual structure.

Positioner Structure--The overall structural design is complete. Final drawing release has been delayed pending decisions on details of the drive mechanism and laser mounting.

Positioner Drive and Control Equipment--Alternative drive techniques are under investigation. Potential accuracy limitations arising from cable stretch and the positioning resolution of simple DC motor control systems need to be resolved.

Antenna Mount Structure--No significant effort has been expended in this area however a potential change to the present concept in order to accommodate heavier antennas than required for the FIREFINDER system is being examined.

System Housing--No activity in this reporting period except for providing Hughes Plant Facilities with space requirements.

Interface and Cabling--Components have been ordered for the A to D interface required for the network analyzer and preliminary interconnection block diagram is complete and shown in Figure 2.

Software Design--An initial functional design specification for the system is complete and is provided as Attachment A to this report. This document provides an outline of the individual computer controlled tasks to be performed by the system and will be the basis for development of specific software flow charting and programming. No problems have been encountered associated with the software design.

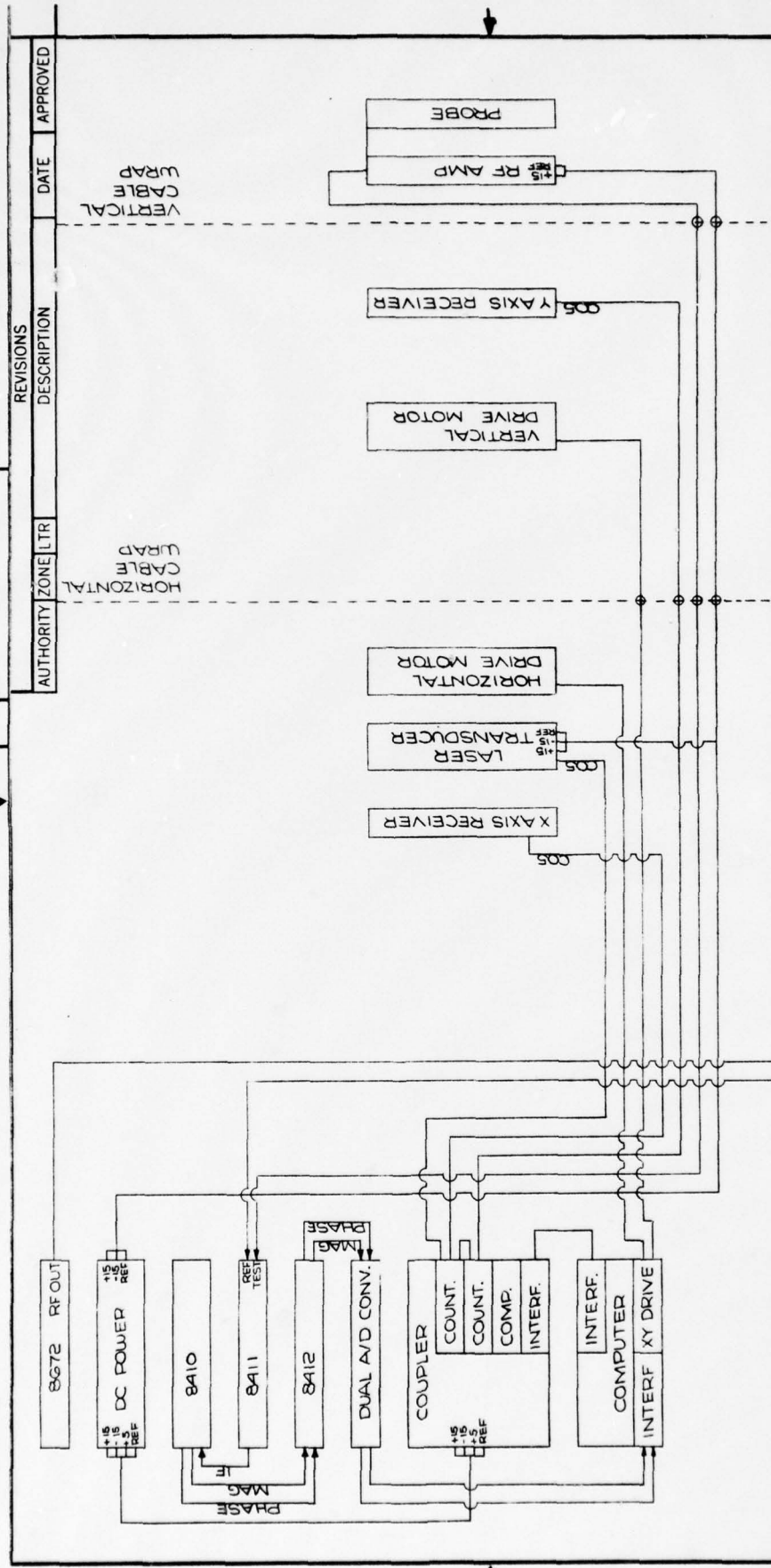

HUGHES HUGHES AIRCRAFT COMPANY FULLERTON, CALIFORNIA		10 JAN 78	EXCEPT AS NOTED DIM ARE IN INCHES AND PER ANS Y14.5 .XXX .XX ANGLES $\pm 0.10 \pm 0.03 \pm 0'30''$ MATERIAL	
Figure 2. System Interconnections.		DR	NEXT ASSY USED ON APPLICATION	
SIZE CODE IDENT NO DRAWING NO. B 05869		CHK	APPLICATION	
SCALE		APPD	SHEET	
REV		8		

REVISIONS	DESCRIPTION	DATE	APPROVED
	HORIZONTAL CABLE WRAP		
	VERTICAL CABLE WRAP		

Control and Data Collection Programming--No specific activities in this area have been started.

Analysis Programming--The National Bureau of Standards, Boulder, Colorado will be used as a consultant in the development and adaptation of analysis programs to the minicomputer system. Paperwork necessary to formalize this consultant contract has been initiated and informal consultations have begun. The analysis software will first be converted to operate on the Hughes-owned Hewlett Packard 3000 computer and then transferred to the near field system computer. This will allow the near field computer to be dedicated to development of the control and data collection software. Transfer of programming between these two computers in this manner will not involve any significant extra programming and will speed up overall program development.

Display Programming--No activity has begun in this area except for gathering of background program data from currently operating display software associated with a number of in-house computers. Figure 3 shows an example of a plot generated by a minicomputer using an electrostatic printer and software converted from an IBM 370 Library program.

System Alignment Procedures--Various concepts for system alignment are being examined as part of the positioner structural design, however no formal procedure development has taken place yet.

Test and Evaluation Procedures--No activity has been started in this area.

Other Activities--In addition to technical program development a meeting was held at Hughes with Mr. J. F. Kelley and Mr. G. R. Teller of ECOM. A number of government and Hughes personnel involved with the FIREFINDER program were also present. Minor contract discrepancies were resolved and discussions relating to the application of the near field measurement system to the FIREFINDER antennas occupied most of the meeting. As a result of these discussions changes to the positioner drive mechanism has been made to eliminate cable stretch as a potential problem.

CONCLUSIONS

At this point in the development program there are no important results which require a change in the proposed program. Details of the positioner drive technique will be somewhat different from that originally proposed (which was identical to the NBS system) however this change will not impact on program cost or schedule. Assessment of progress on a percentage basis is not yet appropriate however at this time there are no specific indications that would suggest any problem in meeting the current program schedule.

PROGRAM FOR THE NEXT QUARTER

A number of major program events should occur during the second quarter. These include:

- Receipt and setup of the computer system
- Receipt and breadboarding of the laser system
- Placement of the positioner structure subcontract
- Flow charting of program segments
- Start of formal consultation with NBS
- Completion of positioner drive and control design.

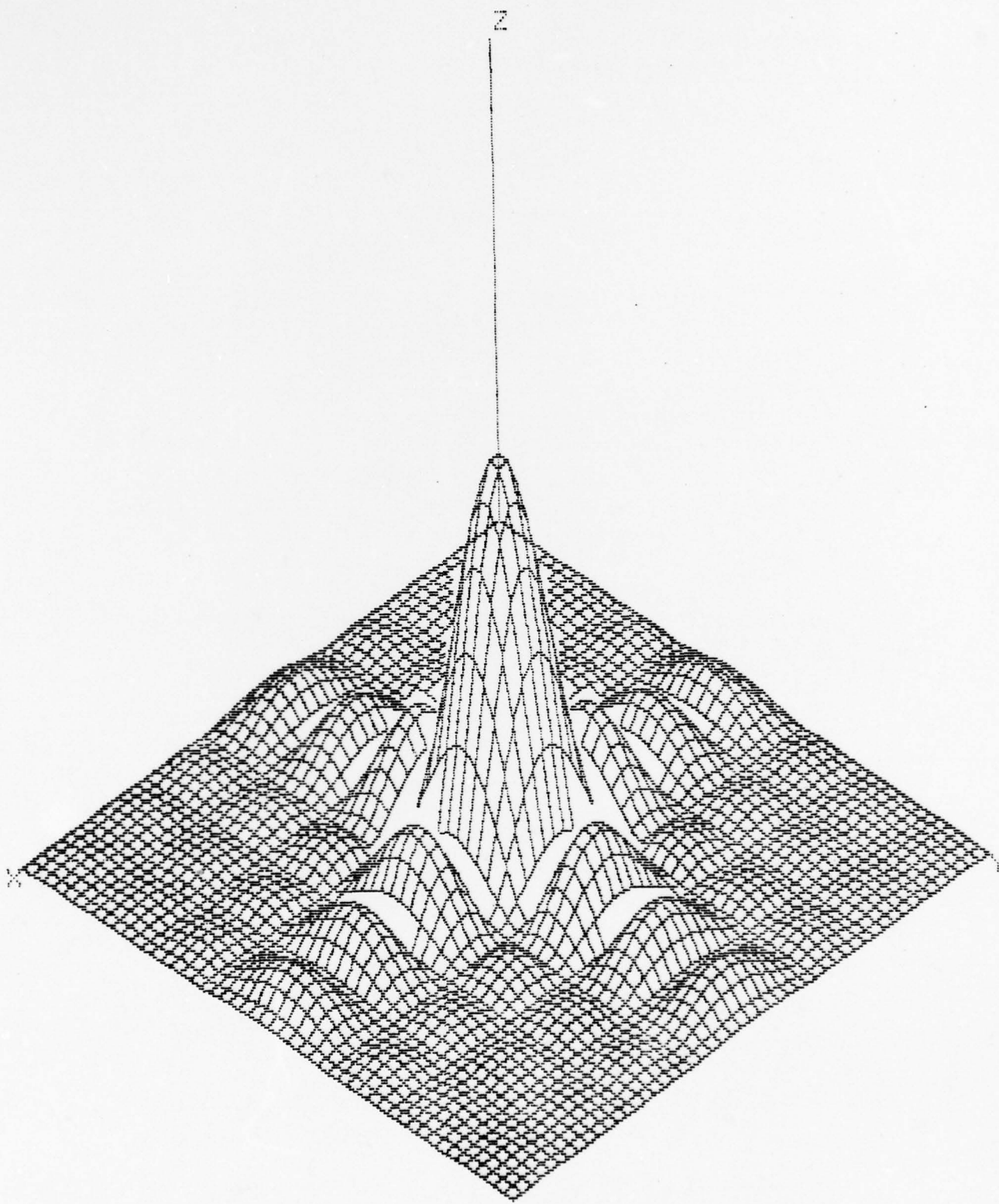

Figure 3. 3D Plot with Hidden Lines Removed.

IDENTIFICATION OF TECHNICIANS

Listed below are the primary technical personnel working on this program, their areas of responsibility, and the time spent during this reporting period. Biographies for those listed are attached.

- Alan E. Holley--Program Manager
- R. W. Howard--Computer hardware, microwave equipment, laser system, control and data collection programming (100 hours).
- D. J. Mecham--Software design, display programming (35 hours).
- R. L. Cummings--Positioner structure, positioner drive and control equipment, antenna mount structure system housing (114 hours).
- W. L. Lange--Analysis programming, test and evaluation procedures (115 hours).

A. E. HOLLEY

Manager
Technical Staff
Electromagnetics Laboratory
Communications and Radar Division

Education:

BS, Physics, Polytechnic Institute of Brooklyn
MS, Physics, University of California at Los Angeles

Experience:

22 years at Hughes
23 years total

Hughes Positions: Mr. Holley has a wide variety of experience in the field of microwave devices, antennas, and instrumentation. He is currently responsible for the acquisition, development, and use of Communications and Radar Division test equipment and facilities and is also senior consultant in the Electromagnetics Laboratory for advanced microwave and antenna programs. He supervises the automated RF test facilities including automatic network and spectrum analyzers as well as the special-purpose computing facilities of the Division. He has been involved in most major hardware programs within the Division including AN/SPS-32/33, SAM-D/CUP, ADAR, AWACS, FLORIDA and has contributed to many of the study programs in providing technical direction for many of the research and development programs in the microwave areas. While associated with the Antenna Department at Hughes Aerospace Group he was involved in many programs involving shaped beam antennas and other optical microwave systems.

Previous Associations: Prior to joining Hughes, Mr. Holley worked on microwave antenna projects at the Naval Research Laboratory and special purpose computer equipment at E. C. Berkley and Associates.

Activities and Honors: IEEE, Professional Groups on Microwave Theory and Techniques, Antennas and Propagation, and Instrumentation and Measurement

R. W. HOWARD

Engineering Programmer
Electromagnetics Laboratory
Communications and Radar Division

Education/Training:

U.S. Air Force Radar Technician School
Fullerton Junior College, pursuant to A.A. in Engineering Technology
Hewlett-Packard Company, specialized computer programming courses

Experience:

18 years at Hughes
4 years as Air Force Radar Technician

Hughes Positions: Mr. Howard has been associated with a number of major programs at Hughes. These include SPS-39/42, SPS-33, ADAR, FLORIDA, AWACS, etc., primarily in the area of microwave design and component test. For the past seven years he has been associated with automatic testing of RF components and subassemblies using both an automatic network analyzer and spectrum analyzer. Mr. Howard is currently responsible for specialized programming efforts on both of these systems and also for generating on-line data collection programming for a Hewlett-Packard 3000 computer system. These programming efforts require the use of FORTRAN, SPL, ASSEMBLY, and BASIC languages.

Previous Experience: Prior to joining Hughes, Mr. Howard was an Airborne Radar Technician in the Air Force performing maintenance on airborne fire control systems.

D. J. MECHAM

Member of the Technical Staff
Electromagnetics Laboratory
Communications and Radar Division

Education:

A.A., Physics/Mathematics, Fullerton Junior College, 1961
A.B., Science, Oregon State University, 1964
M.S., Computer Science, California State University, Chico, 1974

Experience:

5 years at Hughes
13 years total

Hughes Positions: Mr. Mecham directed the implementation and operation of a Real-Time Data Processing Center for a large group of engineers. The Center uses an HP3000 and several peripheral HP2100 computers. Operating systems are performed in batch and timeshare modes. Significant tasks include system programming, user documentation and training for interactive operations, troubleshooting, procurement, data link, graphics, and data collection subsystem design and development, and account management. Computer languages include: user interface dialog languages, AN/FSQ-7 Assembly Language, JOVIAL, ALGOL, FORTRAN, PL/1, BAL, JCL, COBOL, data base management/query/report languages (CDMS).

Previous Experience: Prior to joining Hughes, Mr. Mecham was a Programmer Analyst for System Development Corporation, Santa Monica, California. He performed design and implementation tasks for interactive search and retrieval system operating in a time-sharing (TS/DMS) environment. Machine used was IBM 360/67. Performed system and programming documentation analysis and design. As Computer System Analyst, responsible for design of interface between user and time-shared data management system. The main task was the design and production of the user manual for report description and generation. Other tasks included design and implementation of messages for interactive communication, data base design and generation for specific applications, and data base system training lectures. Had responsibility for computer programs in large-scale, real-time command and control system, SAGE. The programs involved real-time executive, input/output, data link, display, light gun, system simulation, and system utility programs. Designed, tested, and implemented special functions, integrating them into the command and control system programs. Performed system generation and wrote technical documentation.

Activities and Honors: Founder and Past President, HP3000 Users Group
 Past President, Los Angeles Chapter, Association for
 Systems Management

R. L. CUMMINGS

Member of the Technical Staff
Electromagnetics Laboratory
Communications and Radar Division

Education:

BS, Mechanical Engineering, University of Southern California
MS, Mechanical Engineering, University of Southern California

Experience:

11 years at Hughes

Hughes Positions: Mr. Cummings is presently working as the Operations Coordinator on the HP3000 computer. His duties include system programming in three languages (BASIC, FORTRAN and SPL) as well as controlling system operations and providing mechanical design support to the Technical Staff. He worked as a stress and dynamic structures analyst in the Antenna Systems Department. He has been involved in the following projects and studies: Hardsite, AWACS and IPD. He also worked on the design and analysis of the polarizer for the Comsat Domestic Satellite Program.

Activities and Honors: Pi Tau Sigma Mechanical Engineering Honorary Fraternity
Tau Beta Pi Engineering Honorary Fraternity
ASME

W. L. LANGE

Member of the Technical Staff
Array Systems Analysis Group
Array Antenna Section
Antenna Systems Department
Electromagnetics Laboratory
Communications and Radar Division

Education:

BSEE and MSEE, Texas A and M University

Experience:

11 years at Hughes

Hughes Positions: Mr. Lange's responsibilities have included design, analysis, and testing of phased array antennas, single element antennas, and reflector antennas. The phased array antenna programs he has participated in include ADAR, AN/SPS-33, AWACS, COBRA JUDY, and AN/TPQ-36. Mr. Lange used aperture simulation techniques to match the ADAR aperture to space. This included the design and testing of a high power radome. On the AWACS and AN/TPQ-36 programs he was involved in software generation to computer beam forming and beam steering analysis and the effects of errors on pattern performance, and beam location. In AWACS he aided in the design of a sum-difference monopulse feed for elevation tracking. For the sequential lobing AN/TPQ-36 antenna he was involved in creating an algorithm to predict beam position using measured and theoretical data. These tasks have involved considerable antenna pattern range work and computer simulation. Mr. Lange's conformal array experience includes a design effort on a proposed system for COBRA JUDY. The proposed antennas was a cylindrical array with both azimuth and elevation scanning capability.

Mr. Lange aided in the corporate RF feed design for IPD/TAS. This involved the design and testing of high power air dielectric stripline circuits. For the DSCS antenna Mr. Lange did most of the initial computer simulation of the spherical lens antenna. Beam crossovers, null formation and broad beam coverage capabilities were predicted. Single element antenna design and ground propagation studies were performed for a short range communication system. Field testing was done at both L-band and at MF. Mr. Lange's latest task involves the design of RF lenses using optical techniques. These lenses are used to modify feed characteristics to match these feeds to reflector antennas.

Activities

and Honors: Tau Beta Pi, Eta Kappa Nu, Phi Kappa Phi.

FUNCTIONAL DESIGN SPECIFICATIONS FOR THE NEAR FIELD SYSTEM

The following outline covers the primary functions, with a brief description, required to implement the Near Field Probe software system. The functional description below is used to generate specific Software Specifications upon which the actual design will be based.

A. INITIALIZE RTE COMPUTER SYSTEM

START THE COMPUTER PERIPHERALS AND EXECUTE THE NEAR FIELD PROBE SOFTWARE OPERATING SYSTEM.

B. VERIFY ANTENNA LOCATION

PRIOR TO TAKING MEASUREMENTS THE ANTENNA MUST BE ALIGNED.

1. MECHANICAL CONSIDERATIONS

IN ORDER TO INSURE PHYSICAL ALIGNMENT AN OPERATOR MAY BE REQUIRED TO MAKE THE FOLLOWING ADJUSTMENTS

- A) HEIGHT
- B) TWIST
- C) TILT
- D) SPACING

2. SOFTWARE CONSIDERATIONS

COORDINATION OF SOFTWARE AND HARDWARE LOCATION IS PERFORMED BY INITIALIZATION OF THE LASER MEASURING INSTRUMENTATION.

C. CONFIGURE/CALIBRATE/INITIALIZE

A SEQUENCE OF OPERATOR/COMPUTER DIALOG TO ESTABLISH THE TYPE OF ANTENNA TO BE MEASURED AND THE TYPE OF MEASUREMENT TO BE PERFORMED. THIS PROVIDES THE APPROPRIATE SET OF ANTENNA MEASUREMENT PARAMETERS FOR THE DESIRED TESTING. THE FOLLOWING LISTS THE FUNCTIONAL PARAMETERS REQUIRED.

1. MEASUREMENT TYPE DETERMINATION

ESTABLISH WHETHER THE MEASUREMENT WILL BE MADE USING PRE-DETERMINED MEASUREMENT PARAMETERS, OR THE OPERATOR WILL BE INPUTTING THE PARAMETERS ON THE CONSOLE KEYBOARD.

- A) STANDARD MEASUREMENT FOR TPQ-36
PREDETERMINED SET OF MEASUREMENT PARAMETERS FOR TPQ-36
- B) STANDARD MEASUREMENT FOR TPQ-37
PREDETERMINED SET OF MEASUREMENT PARAMETERS FOR TPQ-37
- C) SPECIAL
THERE WILL BE A FUNCTION TO ALLOW THE OPERATOR TO CHANGE THE STANDARD MEASUREMENT PARAMETERS.
- D) DIAGNOSTICS OF TEST ANTENNA
WHILE NOT WITHIN THE SCOPE OF THIS PROJECT CURRENT DESIGN WILL TAKE INTO ACCOUNT POSSIBLE DIAGNOSTIC FUNCTIONS SUCH AS PHASE SHIFTER TESTS.

2. ANTENNA INPUT SIGNAL SPECIFICATION

- A) STANDARD TPQ-36
1 INPUT PORT
- B) STANDARD TPQ-37
3 INPUT PORTS
SUM
AZIMUTH DIFFERENCE
ELEVATION DIFFERENCE
- C) SPECIAL MEASUREMENTS
SPECIAL INPUT SIGNAL SPECIFICATION.

3. MEASUREMENT FREQUENCIES

- A) STANDARD
 - 1) TPQ-36
 - F(0)
 - F(1)
 - F(15)
 - F(16)
 - F(30)
 - F(31)

2)TPQ-37
F(Ø)
F(-)
F(+)

B)SPECIAL

ALLOW OPERATOR INPUT OF SPECIFIC FREQUENCIES.
THIS DATA AND THE # OF BEAM POSITIONS FROM
SEC. 6.5 WILL BE USED TO DETERMINE MEASUREMENT
INCREMENT AND OPTIMUM SCANNER SPEED.

- 1)SINGLE FREQ.
- 2)START,STOP,STEP
- 3)FREQ. SET

4. BEAM POSITIONS

A)STANDARD

1)TPQ-36

1Ø BEAM POSITIONS

AZIMUTH

Ø DEG (*)

-1/3 MAXIMUM BEAM SCAN AZMITH ANGLE

-2/3 MAXIMUM BEAM SCAN AZMITH ANGLE

- MAXIMUM BEAM SCAN AZMITH ANGLE (*)

+1/3 MAXIMUM BEAM SCAN AZMITH ANGLE

+2/3 MAXIMUM BEAM SCAN AZMITH ANGLE

+ MAXIMUM BEAM SCAN AZMITH ANGLE (*)

(*) 3 ADJACENT BEAMS F(Ø),F(15),F(16)

2)TPQ-37

AZIMUTH

Ø DEGREE

-1/3 MAXIMUM BEAM SCAN AZMITH ANGLE

-2/3 MAXIMUM BEAM SCAN AZMITH ANGLE

- MAXIMUM BEAM SCAN AZMITH ANGLE

- MAXIMUM BEAM SCAN AZMITH ANGLE

Ø DEGREE

+1/3 MAXIMUM BEAM SCAN AZMITH ANGLE

+ MAXIMUM BEAM SCAN AZMITH ANGLE

+1/3 MAXIMUM BEAM SCAN AZMITH ANGLE

+2/3 MAXIMUM BEAM SCAN AZMITH ANGLE

ELEVATION

Ø DEGREE

Ø DEGREE

Ø DEGREE

Ø DEGREE

+ MAXIMUM BEAM SCAN AZMITH ANGLE

- MAXIMUM BEAM SCAN AZMITH ANGLE

Ø DEGREE

Ø DEGREE

+1/3 MAXIMUM BEAM SCAN AZMITH ANGLE

+2/3 MAXIMUM BEAM SCAN AZMITH ANGLE

B)SPECIAL

PROVIDES FOR INPUT BY OPERATOR OF SPECIAL BEAM POSITIONS.

5. PROBE PHYSICAL POSITION

THE OPERATOR MUST PERFORM THE FUNCTION OF PHYSICALLY INITIALIZING
AND CONFIGURING THE TEST ANTENNA FOR PROPER RELATIONSHIP TO THE PROBE.

6. MEASUREMENT POLARIZATIONS

THE POLARIZATION FUNCTION IS A PHYSICAL OPERATION BY THE
OPERATOR TO INITIALIZE AND THE POLARIZATION IS COMMUNICATED
TO THE SOFTWARE THROUGH OPERATOR DIALOG.

7. PROBE SCANNER DRIVE CONTROL

THE DRIVER SPEED IS INITIALIZED AND VERIFIED THRU SOFTWARE.

8. ADDITIONAL PARAMETERS

ADDITIONAL PARAMETERS ARE REQUIRED DURING INITIALIZATION I.E.
THE STORAGE FILE NAMES AND REQUIREMENTS FOR COLLECTED AND ANALYZED
DATA.

D. SYSTEM VERIFICATION

IN ORDER TO INSURE THE CORRECT OPERATION OF THE TEST/DATA COLLECTION
EQUIPMENT A VERIFICATION FUNCTION IS PERFORMED FOR THE FOLLOWING
ITEMS.

1. FREQ CONTROLLER
2. BEAM POSITIONER
3. LASER

E. PRELIMINARY DATA ANALYSIS & DISPLAY

1. COLLECT SPECIAL SET OF DATA

THE INITIAL ABBREVIATED TEST CONSISTING OF
MEASURING A SINGLE CENTRAL ROW WITH TWO FREQUENCIES
AND TWO BEAM SCANS IS PERFORMED PRIOR TO THE MAIN
DATA COLLECTION MEASUREMENTS TO VERIFY ANTENNA SET UP.

INITIALIZE X INCREMENT IN MEASUREMENT SEQUENCE TABLE
POSITION PROBE TO ORIGIN (X(0),Y(MIDDLE))
START Y DRIVE
MONITOR MEASUREMENT SEQUENCE TABLE & LASER FOR MEASUREMENT LOCATION
MEASURE & STORE DATA AT EACH CO-INCIDENCE
SET FREQ & BEAM POS FOR NEXT MEAS
CONTINUE FOR DURATION OF Y RANGE

2. ANALYZE PRELIMINARY DATA

AN ANALYSIS IS PERFORMED ON THE SPECIAL DATA MEASUREMENT TO INSURE THAT THE ANTENNA AND MEASUREMENT EQUIPMENT ARE IN WORKING ORDER AND ALL PARAMETERS ARE WITHIN EXPECTED SPECIFICATIONS.

PLOT AMPLITUDE AND PHASE
PLOT COMPUTED FAR FIELD PATTERN (SEE G.1)
EVALUATE DATA AND MAKE DECISION TO CONTINUE TESTING.
AMPLITUDE SHOULD FALL WITHIN SPECIFIED CONSTRAINTS
FAR FIELD PATTERN SIDELOBES SHOULD BE BELOW THE SPECIFIED DB VALUE.
FAR FIELD BEAM LOCATIONS SHOULD BE WITHIN SPECIFICATIONS

F. DATA COLLECTION

THE COLLECTION OF MEASURED DATA IS TAKEN BY DRIVING THE PROBE ALONG VERTICAL PATHS.

1. INITIALIZE MEASUREMENT SEQUENCE TABLE

A. X INCREMENT

THE HORIZONTAL SPACING BETWEEN VERTICAL SWEEPS OF THE SCANNER. THIS VALUE WILL BE EQUAL TO 1/2 WAVELENGTH AT THE HIGHEST TEST FREQUENCY.

B. Y INCREMENT

THIS IS THE SET OF VERTICAL SCANNER LOCATIONS THAT WILL CONTROL DATA TAKING. ONE MEASUREMENT OF AMPLITUDE AND PHASE WILL BE MADE AT EACH 1/2 WAVELENGTH LOCATION FOR THE HIGHEST TEST FREQUENCY FOR EVERY MULTIPLEXED BEAM SETTING.

2. POSITION PROBE TO ORIGIN (X(0),Y(0))

COMPUTER POSITIONS THE SCANNER TO THE UPPER LEFT-HAND CORNER OF THE SCAN WINDOW.

3. START Y DRIVE

THE Y AXIS DRIVE MOTOR IS STARTED AT AN OPTIMUM SPEED FOR THE DATA TO BE TAKEN.

4. MONITOR MEASUREMENT SEQUENCE TABLE & LASER FOR MEASUREMENT LOCATION

5. MEASURE & STORE DATA AT EACH CO-INCIDENCE

AS EACH MEASUREMENT LOCATION IS ENCOUNTERED BY COMPARING THE LASER POSITION TO THE MEASUREMENT SEQUENCE TABLE, THE AMPLITUDE AND PHASE DATA ARE DIGITIZED AND STORED IN A TEMPORARY STORAGE AREA.

6. SET FREQ & BEAM POS FOR NEXT MEASUREMENT

THE SYNTHESIZER AND BEAM POSITIONER ARE SET TO THE VALUES FOR THE NEXT POINT OF CO-INCIDENCE IN THE MEASUREMENT SEQUENCE TABLE.

7. CONTINUE FOR DURATION OF Y RANGE

8. RE-POSITION PROBE TO Y(0),X(N)

DURING THE RETURN OF THE SCANNER TO THE BEGINNING OF THE VERTICAL SWEEP, THE MEASURED DATA WILL BE STORED IN THE APPROPRIATE DISC FILES. THE FILE POINTERS WILL NOT BE INCREMENTED UNTIL AFTER THE COMPLETION OF THE PRELIMINARY ANALYSIS.

9. PERFORM PRELIMINARY ANALYSIS OF INTERMEDIATE DATA

TO INSURE DATA VALIDITY AS THE MEASUREMENTS ARE BEING PERFORMED IT IS DESIREABLE TO PERFORM PRELIMINARY TESTS AND DISPLAYS OF EACH COLUMN OF DATA AS IT IS COLLECTED.

10. DISPLAY INTERMEDIATE DATA

11. EVALUATE ONE VERTICAL SCAN OF DATA

THE COMPUTER WILL NOT POSITION THE SCANNER TO THE BEGINNING OF THE NEXT VERTICAL SWEEP UNTIL ANY PROBLEMS WITH THE DATA TAKEN ON THE LAST VERTICAL SCAN HAVE BEEN RESOLVED.

12. CONTINUE TO SWEEP, ANALYZE, & STORE DATA FOR TOTAL ANTENNA AREA

G. COMPLETE ANALYSIS

1. COMPUTE FAR FIELD PATTERN
OBTAIN MEASUREMENT CONFIGURATION DATA WHICH SPECIFIES PATTERN TYPE, FREQUENCY AND PATTERN PARAMETERS TO BE ANALYZED.
OBTAIN INPUT MEASURED DATA, AMPLITUDE AND PHASE TRANSPOSE OR REARRANGE MEASURED DATA AS REQUIRED
PERFORM FAST FOURIER TRANSFORM (FFT) OR CHIRP-Z TRANSFORM OF MEASURED DATA. THE CHIRP-Z TRANSFORM IS USED WHERE FINE PATTERN GRANULARITY IS REQUIRED AS IN BEAM POINTING AND BEAMWIDTH COMPUTATION. THE FFT IS USED FOR SIDELobe LEVEL DETERMINATION.
REARRANGE DATA
THE FFT OUTPUT HAS THE BEAM SPLIT. DATA REARRANGEMENT IS REQUIRED TO CENTER THE BEAM.
PERFORM PROBE CORRECTION
OBTAIN MEASUREMENT PARAMETER DATA
OBTAIN PROBE AMPLITUDE AND PHASE PATTERN DATA
INTERPOLATE MEASURED PROBE DATA--CONVERT TO KX, KY
NORMALIZE DATA
COMPUTE ABSOLUTE ANTENNA GAIN USING NORMALIZED DATA.
DETERMINE BEAM PEAK LOCATIONS WITH UNNORMALIZED DATA.
DETERMINE SIDELobe LEVELS USING NON-NORMALIZED DATA.
CONVERT KX, KY TO THETA, PHI COORDINATES
THE FFT OUTPUT IS IN KX, KY COORDINATES.
COMPARE NEAR FIELD DATA WITH FAR FIELD DATA BY CONVERTING THE DATA TO THETA, PHI COORDINATES.

2. COMPLETE ANALYSIS

PATTERN RESULTS

THE NEAR FIELD DATA ALLOWS THE USER TO DETERMINE ALL THE ANTENNA PARAMETERS NORMALLY MEASURED ON A FAR FIELD RANGE. THE FOLLOWING TPQ-36 PARAMETERS WILL BE COMPUTED.

TPQ-36

SIDE LOBE LEVEL
BEAM CROSSOVER LOCATIONS
GAIN
BEAMWIDTH

TPQ-37

SIDE LOBE LEVELS
BEAM POSITIONS
GAIN
DIFFERENCE PATTERN SLOPE
BEAMWIDTH

GRAPHIC OUTPUT DISPLAY

PLOTTED PATTERNS WILL DISPLAY PATTERN POWER IN DB VERSUS ANTENNA ANGLE. PATTERN LABELING WILL INCLUDE ANTENNA TYPE, FREQUENCY CODE, AZIMUTH OR ELEVATION CUT, AND BEAM SCAN.
LINEAR PATTERNS
CONTOUR PATTERNS
3-D PATTERNS

H. DATA DISPLAY

A TABLE DERIVED FROM TEST SPECIFICATIONS WILL BE PRINTED OUT. GRAPHICS WILL BE OPERATOR SELECTED. ALL RAW DATA FILES WILL BE STORED ON TAPE. COMPUTED DATA FILES, INCLUDING OUTPUT FROM THE FFT AND CHIRP-Z ROUTINES, MAY BE STORED ON TAPE UPON OPERATOR REQUEST.

I. DATA STORAGE CAPABILITIES

STORE RAW DATA ON TAPE
CREATE A SEPARATE 2-DIMENSIONAL ARRAY (X VS. Y) FOR EACH FREQUENCY AND BEAM POSITION.
RETRIEVE RAW DATA FROM TAPE
STORE PROCESSED DATA ON TAPE
RETRIEVE PROCESSED DATA FROM TAPE
STORE OR RETRIEVE TEST PARAMETER DATA ON TAPE

J. TERMINATE RTE

K. ERROR DETECTION & PROCESSING

1. MECHANICAL DRIVE LIMITS
PROVIDE A MEANS OF STOPPING SCANNER DRIVE AT EITHER EXTREME OF THE SCANNER RANGE.
2. EXCESSIVE PROBE RATE OF TRAVEL
SOFTWARE FUNCTION TO INSURE THAT THE SCANNER IS NOT BEING DRIVEN TOO FAST FOR THE MEASUREMENT.
3. LASER FAULT
SOFTWARE TO INSURE THAT LASER BEAM HAS

NOT BEEN INTERRUPTED.
4. BEAM POSITIONER FAULT

L. UTILITY & SUPPORT ROUTINES

1. STANDARD MEASUREMENT CONFIGURATIONS

TABLES OF VALUES AS OUTLINED IN SECTION C.

2. SPECIAL MEASUREMENT MEASUREMENT SEQUENCE TABLES

GENERATE A SPECIAL MEASUREMENT SEQUENCE TABLE FOR A COMPLETE DATA ANALYSIS.

3. SPECIAL MEASUREMENT CONFIGURATIONS

SPECIFY A SPECIAL SET OF DATA MEASURING AND ANALYSIS OPTIONS. THIS WOULD INCLUDE NON-SWEEP CONTROL AND MEASUREMENT.

4. OPERATOR DIALOG

DIALOG WITH THE OPERATOR IS PERFORMED USING THE FOLLOWING FUNCTIONS SYNTAX SCANNER, SEMANTIC ANALYZER, MESSAGE HANDLER

5. DATA STORAGE (TAPE)

COLLECTED AND ANALYZED SETS OF DATA MAY BE ARCHIEVED ON MAGNETIC TAPE

6. FILE HANDLING

ALL FILE HANDLING FUNCTIONS ARE HANDLED BY THE HP RTE OPERATING SYSTEM

7. PLOTTING & GRAPHICS FUNCTIONS

THE FOLLOWING GRAPHICS FUNCTIONS PROVIDE THE NEAR FIELD APPLICATION'S PROGRAMS WITH THE ABILITY TO DISPLAY DATA IN GRAPHIC/PLOT FORMAT ON THE HARD COPY PLOTTER OR CRT GRAPHICS TERMINAL. THE BASIC TWO DIMENSIONAL PLOT PACKAGE IS BASED ON THE EXISTING VERSAPLOT SOFTWARE PACKAGE WITH ALL ITS ATTRIBUTES.

A. 2 DIMENSIONAL PLOTTING CHARACTERISTICS

THE 2-DIMENSIONAL FUNCTIONS WILL PROVIDE FOUR DIFFERENT PLOT TYPES WITH OPTIONAL PLOT BACKGROUND INFORMATION OUTPUT ON THE HARD COPY PLOTTER. A LIMITED SUBSET OF THESE FUCTIONS WILL BE AVAILABLE ON THE GRAPHICS CRT TERMINAL.

- POINT PLOT
- LINE PLOT
- CONTOUR PLOT
- POINT SYMBOL PLOT
- AXES X & Y
- AXES TIC MARKS
- AXES LABELS
- PLOT TITLE
- OPTIONAL GRID
- TONAL SHADING

B. 3 DIMENSIONAL PLOTTING CHARACTERISTICS

THE 3-DIMENSIONAL FUNCTIONS WILL PROVIDE TWO DIFFERENT PLOT PERSPECTIVES. THE FIRST IS A THREE DIMENSIONAL GRID PLOT AND THE SECOND SHOWS CONTOURS

- MESH PERSPECTIVE PLOT
- CONTOUR PLOT
- AXES LABELS
- PLOT TITLING

C. CRT DISPLAY GRAPHICS

THE CRT GRAPHICS ARE LIMITED TO SIMPLE PLOTS FOR PURPOSES OF REVIEWING DATA. PLOT MAY BE COPIED ON THE VERSATEC.

- POINT PLOT-I.E. RAW AMPLITUDE OR PHASE DATA
- LINE PLOT-I.E. CONVENTIONAL ANTENNA PATTERNS
- 3 DIMENSIONAL MESH PERSPECTIVE PLOT

D. UILITY

THE UTILITY FUNCTIONS AND PROGRAMS ASSOCIATED WITH THE VERSAPLOT SOFTWARE INCLUDE THE FOLLOWING LIST. GENERALLY, THESE FUNCTIONS WILL BE USED IMPLICITLY ALTHOUGH THEY WILL BE MADE AVAILABLE FOR SPECIAL OPERATOR USE.

- SORTING VECTORS
- VECTOR TO RASTOR CONVERSION
- CRT PLOT GENERATION
- CRT PLOT LABEL GENERATION
- GRAPHIC SHADING PATTERN DESIGNATION

- LINE TYPE DESIGNATION
- SPECIAL CHARACTER GENERATION

M. NON-SWEEP PROBE CONTROL & MEASUREMENT

WHILE NOT INCLUDED IN THIS PROJECT THE SOFTWARE DESIGN WILL PROVIDE POTENTIAL NON-SWEEP PROBE CONTROL AND SPECIFIED DATA MEASUREMENT PARAMETERS.

N. STANDARD COMPUTER SYSTEM SOFTWARE FUNCTIONS

THERE ARE A NUMBER OF SOFTWARE ELEMENTS THAT ARE PROVIDED WITH THE HP1000 COMPUTER SYSTEM

REAL-TIME EXECUTIVE - CONTROLS ALL SOFTWARE OPERATION, PERFORMS SYSTEM FUNCTIONS, SYSTEM UTILITY FUNCTIONS, AND CONTROLS ALL PERIPHERAL INTERFACE FUNCTIONS.

FILE MANAGER - PROVIDES UTILITY FUNCTIONS TO CREATE, UPDATE, PURGE, LIST, COPY, ETC. DISC AND MAGNETIC TAPE FILES.

HP FORTRAN II - COMPILER
RTE FORTRAN IV - COMPILER
HP ALGOL - COMPILER
HP EDITOR - TEXT EDITING
RTE ASSEMBLER - HP21MX ASSEMBLER
LOADER - LINK-EDITOR
SYSTEM DIAGNOSTICS

UNCLASSIFIED

SECURITY CLASSIFICATION OF THIS PAGE (When Data Entered)

REPORT DOCUMENTATION PAGE		READ INSTRUCTIONS BEFORE COMPLETING FORM
1. REPORT NUMBER FR 78-14-338A ✓	2. GOVT ACCESSION NO.	3. RECIPIENT'S CATALOG NUMBER
4. TITLE (and Subtitle) First Quarterly Report	5. TYPE OF REPORT & PERIOD COVERED Quarterly 29 August 1977-November 1977	
	6. PERFORMING ORG. REPORT NUMBER	
7. AUTHOR(s) Hughes Aircraft Company 1901 West Malvern Fullerton, California 92634	8. CONTRACT OR GRANT NUMBER(s) DAAB07-77-C-0587 <i>new</i>	
9. PERFORMING ORGANIZATION NAME AND ADDRESS Hughes Aircraft Company ✓ 1901 West Malvern Fullerton, California 92634	10. PROGRAM ELEMENT, PROJECT, TASK AREA & WORK UNIT NUMBERS 2779873	
11. CONTROLLING OFFICE NAME AND ADDRESS U.S. Army Electronics Command P and P Directorate W15P7R Fort Monmouth, New Jersey 07703	12. REPORT DATE 11 January 1978	
	13. NUMBER OF PAGES 22	
14. MONITORING AGENCY NAME & ADDRESS (if different from Controlling Office) U.S. Army Electronics Command P and P Directorate W15P7R Fort Monmouth, New Jersey 07703	15. SECURITY CLASS. (of this report) Unclassified	
	15a. DECLASSIFICATION/DOWNGRADING SCHEDULE	
16. DISTRIBUTION STATEMENT (of this Report) See attached distribution list <div style="border: 1px solid black; padding: 5px; display: inline-block; text-align: center;"> DISTRIBUTION STATEMENT A Approved for public release; Distribution Unlimited </div>		
17. DISTRIBUTION STATEMENT (of the abstract entered in Block 20, if different from Report) Same		
18. SUPPLEMENTARY NOTES None		
19. KEY WORDS (Continue on reverse side if necessary and identify by block number) Antenna Measurements Near Field Probe Automated Measurements		
20. ABSTRACT (Continue on reverse side if necessary and identify by block number) The report describes the first three months activity in the development of a fully self-contained automated near field antenna measurement facility. A description of the system is included.		

UNCLASSIFIED

DISTRIBUTION LIST

Contract DAAB07-77-C-0587

Commander Defense Documentation Center ATTN: DDC-TCA Cameron Station, Building 5 Alexandria, VA 22314	12	Commander Tobyhanna Army Depot ATTN: Mr. W. Coniff Tobyhanna, PA	1
Commander US Army Materiel Development and Readiness Command ATTN: DRCRD-RS-PE-E, DRCRE-CMT 5001 Eisenhower Avenue Alexandria, VA 22333	2	Commander US Army Research Office ATTN: DRXRO-IP PO Box 12211 Research Triangle Park, NC 27709	1
Office of Defense Research & Engineering Communications and Electronics Room 3D1037 Washington, DC 20330	1	Commander US Army ERADCOM Technical Support Activity ATTN: DELSD-D-PC Fort Monmouth, NJ 07703	2
Director US Army Production Equipment Agency ATTN: Mr. C. McBurney Rock Island Arsenal Rock Island, IL 61201	1	Commander US Army Missile Command Redstone Scientific Info Center ATTN: Chief, Document Section Redstone Arsenal, AL 35809	1
Department of Defense Deputy for Science & Technology Ofc Assist Sec Army (R&D) Washington, DC 20310	1	US Army Missile Command ATTN: DRSMI-RGP (Mr. Victor Ruwe) Redstone Arsenal, AL 35809	1
Advisory Group on Electron Devices 201 Varick Street, 9th Floor New York, NY 10014	2	Commander Harry Diamond Laboratories ATTN: Mr. Horst Gerlach (DRXDO-RAA) 2800 Powder Mill Road Adelphia, MD 20783	1
Chief, Research & Development ATTN: Director of Developments Department of the Army Washington, DC 20310	1	Commander Naval Electronics Laboratory Center ATTN: Library San Diego, CA 92152	1
Director Electronic Components Laboratory ATTN: DRSEL-RD-ER-2 Fort Monmouth, NJ 07703	1	Commander Department of the Navy, Elex 05143A ATTN: A. H. Young Electronics System Command Washington, CD 20360	1

DELS-D-PC
Distribution List

Commander US Army Electronics Research and Development Command ATTN: DELET-TL-IC Fort Monmouth, NJ 07703	2	AFAL (AVTA) Electronic Technology Division ATTN: Mr. Robert D. Larson, Chief Advanced Electronics Devices Branch Wright-Patterson Air Force Base Dayton, OH 45433	1
Chief Naval Ship Systems Command Department of the Navy ATTN: Code 681A2b, Mr. L. Gumina Room 3329 Washington, DC	1	NASA Scientific & Tech Information Facility PO Box 8759 Baltimore/Washington Int'l Airport	2
Commander US Naval Air Development Center ATTN: Library Johnsville, Warminster, PA 18974	2	National Aeronautics & Space Administration George C. Marshall Space Flight Center ATTN: R-QUAL-FP (Mr. Leon C. Hamiter) Huntsville, AL 35812	1
Commander Naval Ocean Systems Command ATTN: Mr. Richard Gamble San Diego, CA 92152	1	NSSA-Manned Space Craft Center Reliability and Flight Safety Division ATTN: Library Houston, TX	1
Commander Air Research & Development Command ATTN: RDTCT Andrews Air Force Base Washington, DC	1	Bell Laboratories Whippany Road ATTN: Tech Reports Center WH5E-227 Whippany, NJ 07981	1
Commander Rome Air Development Center Griffiss Air Force Base ATTN: EMERR (Mr. L. Gubbins) Rome, NY 13440	1	Arthur D. Little Acorn Park ATTN: Dr. H. Rudenberg 15/206 Cambridge, MA 02140	1
Commander Air Force Materials Laboratory ATTN: MATE (Ms. E. Torrance) Electronic Branch Wright-Patterson Air Force Base Dayton, OH 45433	1	Georgia Institute of Technology Engineering Experimental Station Atlantic, GA	1
Commander Rome Air Development Center Griffiss Air Force Base ATTN: EMERR (Mr. Regis C. Hilow) Rome, NY 13440	1	Dr. Robert H. Rediker Massachusetts Institute of Technology Building 13-3050 Cambridge, MA 02139	1
	1	Rockwell International Collins Radio Group ATTN: Dr. Cheng Wen MS 406-246 Dallas, TX 75207	1

DEISD-D-PC
Distribution List

Northrop Corporation Laboratories ATTN: Library 320-61 3401 West Broadway Hawthorne, CA 90250	1	PRD Electronics Inc ATTN: Mr. Frank Chiappone 6801 Jericho Turnpike Syosset, NY 11791	1
Rockwell International Corporation Science Center Thousand Oaks, CA	1	AAI Corporation ATTN: Mr. K. Raines PO Box 6767 Baltimore, MD 21204	1
Lockheed Electronic Co. Inc. US Highway 22 ATTN: Mr. A. Eisenberger, MS 138 Plainfield, NJ 07061	1	Texas Instruments ATTN: Technical Reports Service PO Box 5936, MS 105 Dallas, TX 75222	1
Sanders Associates, Inc. ATTN: Microwave Department 95 Canal Street Nashua, NH 03060	1	Singer Librascope Systems Division ATTN: Mr. Philop W. LaClair 808 Western Avenue Glendale, CA 91201	1
Scientific Atlantic Inc ATTN: Mr. Gerald Hickman 3845 Pleasantdale Road Atlantic, GA 30340	1	Raytheon ATTN: Library 141 Spring Street Lexington, MA	1
College of Engineering The University of Tennessee Knoxville, TN 37916	1	Singer Kearfott Division ATTN: Mr. L. A. Smith 1150 McBride Avenue Little Falls, NJ 07424	