

AD-A052 652

AIRESEARCH MFG CO OF ARIZONA PHOENIX  
ADVANCED TECHNOLOGY SERVICING EQUIPMENT FOR ARMY AIRCRAFT.(U)

F/G 1/5

DEC 77 R R MEJDRICH  
31-2491B

DAAJ02-76-C-0042

UNCLASSIFIED

USAAMRDL-TR-77-33

NL

1 OF 2  
AD A052652



AD A 052652

USAAMRDL-TR-77-33

12  
52



**ADVANCED TECHNOLOGY SERVICING EQUIPMENT FOR  
ARMY AIRCRAFT**

R. R. Mejdrich

AiResearch Manufacturing Company of Arizona  
402 S. 36th Street  
Phoenix, Ariz. 85034

DDC FILE COPY

December 1977

Final Report

DDC  
RECEIVED  
APR 4 1978  
A

Approved for public release;  
distribution unlimited.

Prepared for

APPLIED TECHNOLOGY LABORATORY  
U. S. ARMY RESEARCH AND TECHNOLOGY LABORATORIES (AVRADCOM)  
Fort Eustis, Va. 23604

## APPLIED TECHNOLOGY LABORATORY POSITION STATEMENT

This report was prepared by the AiResearch Manufacturing Company under contract DAAJ02-76-C-0042. It relates the approach, trade-offs, and selected configuration description of a multiple output ground power unit that could supply all necessary ground power inputs to the UH-60A UTTAS, YAH-64 AAH, and CH-47D Army helicopters. The report and associated layout drawings, along with a hardware procurement specification, were the objectives of a Ground Power Unit concept formulation and configuration selection required by the contract.

Finite Ground Power Unit performance and mobility requirements were described in the contract Statement of Work. The numerous options to achieve the requirements, with relative effects on the trade-off characteristics, are described in the report. It was concluded that gas turbine power is optimum for achieving the lowest weight and volume. Surveys of off-the-shelf components provided options which permitted subsystem generation without requiring component development. The depth of analysis is very good, and the final concept selected permits a high degree of confidence in the probability of successfully achieving the required performance from hardware built to the selected definition.

The selected Ground Power Unit configuration described in the report and the associated specification is to be fabricated into concept validation models that can be tested on the applicable helicopters to verify the simultaneous, multiple output of ground power parameters.

This report has been reviewed by the appropriate technical personnel of this Directorate, who concur with the conclusions contained herein. The U. S. Army Project Engineer for this effort was Mr. R. L. Campbell, Sr. of the Military Operations Technology Division.

### DISCLAIMERS

The findings in this report are not to be construed as an official Department of the Army position unless so designated by other authorized documents.

When Government drawings, specifications, or other data are used for any purpose other than in connection with a definitely related Government procurement operation, the United States Government thereby incurs no responsibility nor any obligation whatsoever; and the fact that the Government may have formulated, furnished, or in any way supplied the said drawings, specifications, or other data is not to be regarded by implication or otherwise as in any manner licensing the holder or any other person or corporation, or conveying any rights or permission, to manufacture, use, or sell any patented invention that may in any way be related thereto.

Trade names cited in this report do not constitute an official endorsement or approval of the use of such commercial hardware or software.

### DISPOSITION INSTRUCTIONS

Destroy this report when no longer needed. Do not return it to the originator.

UNCLASSIFIED  
SECURITY CLASSIFICATION OF THIS PAGE (When Data Entered)

19. REPORT DOCUMENTATION PAGE		READ INSTRUCTIONS BEFORE COMPLETING FORM
1. REPORT NUMBER 28 USAAMRDL TR-77-33	2. GOVT ACCESSION NO.	3. RECIPIENT'S CATALOG NUMBER
4. TITLE (and Subtitle) 6 ADVANCED TECHNOLOGY SERVICING EQUIPMENT FOR ARMY AIRCRAFT.	8. TYPE OF REPORT & PERIOD COVERED 9 Final Technical Report,	PERFORMING ORG. REPORT NUMBER 14 31-2491B
7. AUTHOR(S) 20 R.R. Mejdrich	10. PROGRAM ELEMENT, PROJECT, TASK AREA & WORK UNIT NUMBERS 622097 AF262209AH76 1700 153 EX	11. CONTRACT OR GRANT NUMBER(s) 15 DAAJ02-76-C-0042 new
9. PERFORMING ORGANIZATION NAME AND ADDRESS AiResearch Manufacturing Company of Arizona 402 So. 36 St., Phoenix, Arizona 85034	12. REPORT DATE 21 December 77	13. NUMBER OF PAGES 193 12 195P
11. CONTROLLING OFFICE NAME AND ADDRESS Applied Technology Laboratory, U.S. Army Research & Technology Laboratories (AVRADCOM), Fort Eustis, Virginia 23604	14. MONITORING AGENCY NAME & ADDRESS (if different from Controlling Office)	15. SECURITY CLASS. (of this report) Unclassified
15a. DECLASSIFICATION/DOWNGRADING SCHEDULE		
16. DISTRIBUTION STATEMENT (of this Report) Approved for public release; distribution unlimited.		
17. DISTRIBUTION STATEMENT (of the abstract entered in Block 20, if different from Report)		
18. SUPPLEMENTARY NOTES		
19. KEY WORDS (Continue on reverse side if necessary and identify by block number) Army Aircraft Army Helicopter Advanced Ground Power Unit Study Program		
20. ABSTRACT (Continue on reverse side if necessary and identify by block number) The purpose of this effort was to define an advanced Ground Power Unit (GPU) to service AAH and UTTAS helicopters. The GPU was to be lightweight, air-transportable, highly mobile, and use aircraft equipment wherever possible. → om		

DD FORM 1 JAN 73 1473 EDITION OF 1 NOV 65 IS OBSOLETE

UNCLASSIFIED  
SECURITY CLASSIFICATION OF THIS PAGE (When Data Entered)

404 796 JOB

UNCLASSIFIED

SECURITY CLASSIFICATION OF THIS PAGE(When Data Entered)

Block 20 (Contd)

The program included the following activities:

- ⊗ Aircraft requirements verification;
- ⊗ Trade-off analyses to select specific components;
- ⊗ Design and component compatibility verification; and
- ⊗ Preparation of specification and layout drawings defining conceptual design.

ACCESSION for	
NTIS	White Section <input checked="" type="checkbox"/>
DDC	Self Section <input type="checkbox"/>
UNANNOUNCED	<input type="checkbox"/>
JUSTIFICATION	
BY	
DISTRIBUTION/AVAILABILITY CODES	
Dist.	AVAIL. num./or SPECIAL
A	

UNCLASSIFIED

SECURITY CLASSIFICATION OF THIS PAGE(When Data Entered)

## SUMMARY

The purpose of this effort was to define an advanced Ground Power Unit (GPU) to service AAH and UTTAS helicopters. The GPU was to be lightweight, air-transportable, and highly mobile, and use aircraft equipment wherever possible to eliminate component development and simplify GPU logistics.

Prior to initiating concept selection activities, the program problem statement was verified through visits and interviews with airframe manufacturers. Based on data gathered during these visits, 14 power generation subsystems, 3 mobility systems, and 2 enclosure systems were defined (as shown in Figure 1) and then evaluated through a series of trade-off analyses. Evaluation factors used in the trade-offs were weight, volume, mobility, cost, reliability, and maintainability. A series of weighting factors was devised for the trade-off analyses, and a simple arithmetic comparison of various candidates was performed from which an optimum GPU concept was selected. This concept was then compared with existing, current fleet, aircraft requirements, and necessary changes to the concept were defined. This information was then presented to a committee of Army personnel representing Aviation Systems Command (AVSCOM), Air Mobility Research and Development Laboratory (AMRDL), Training and Doctrines Command (TRADOC), Program Manager-Mobile Electric Power (PM-MEP) and the AAH-Program Management Office (AAH-PMO).

As a result of this presentation, an Army decision was made to limit GPU applicability to the YAH-64 (AAH), UH-60A (UTTAS), and CH-47D helicopters since these aircraft will comprise the bulk of the Army VTOL fleet requiring 115 VAC, 400 Hz and hydraulic ground power. The GPU concept selected is gas turbine-engine-driven, having an integral bleed capability and an integral two-pad gearbox. The driven accessories are a 12,000-rpm air cooled alternator and a 6000-rpm hydraulic pump. The unit is self-propelled using hydraulic drive motors, and is housed in a fiberglass enclosure as depicted in Figure 2.

The GPU concept was optimized, and specification and layout drawings defining the concept were prepared.

In parallel with specifications and drawings, the use of an advanced auxiliary power unit (APU) engine was evaluated. Analyses were performed of integral bleed versus shaft driven compressor; wide range, variable geometry versus interstage bleeding; and exhaust acoustic treatments versus recuperation.



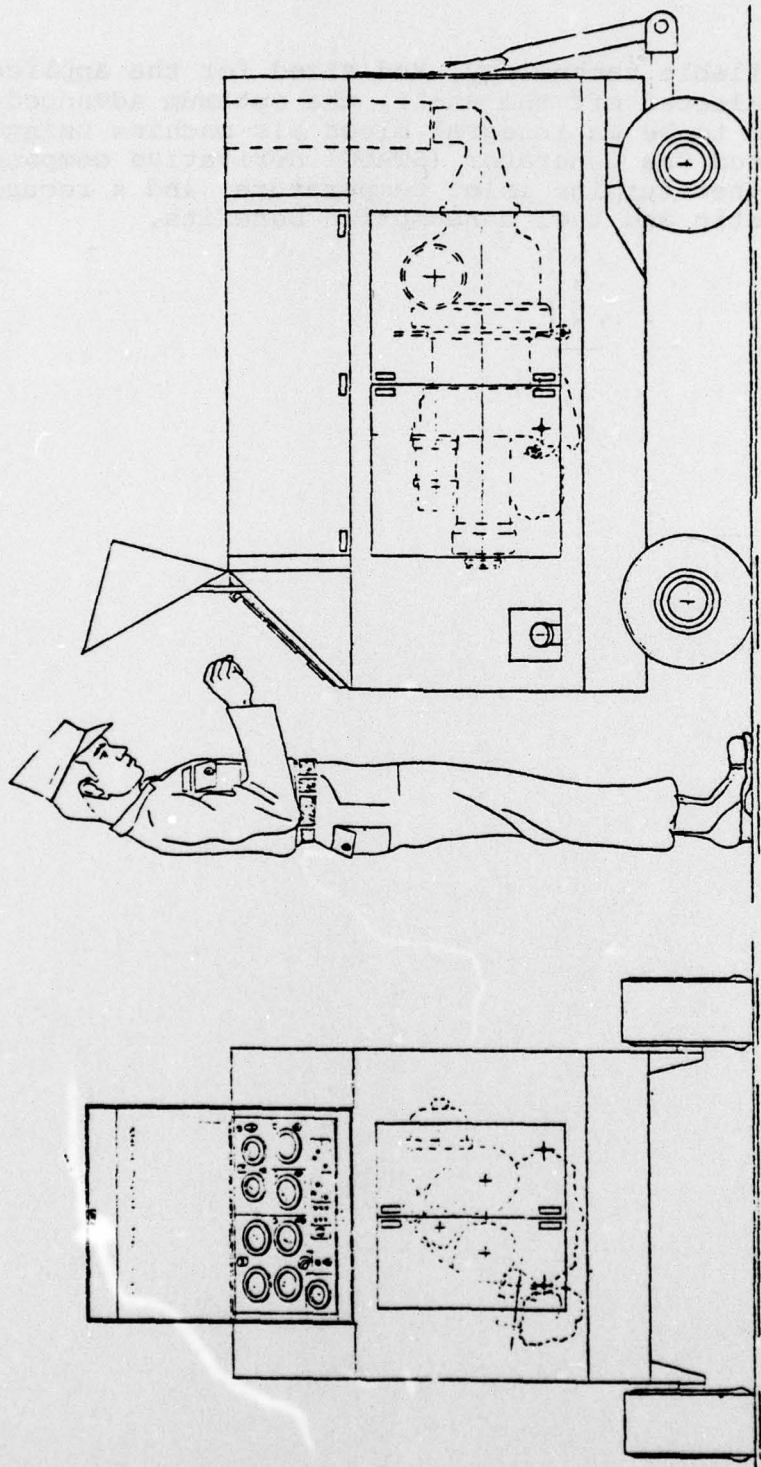
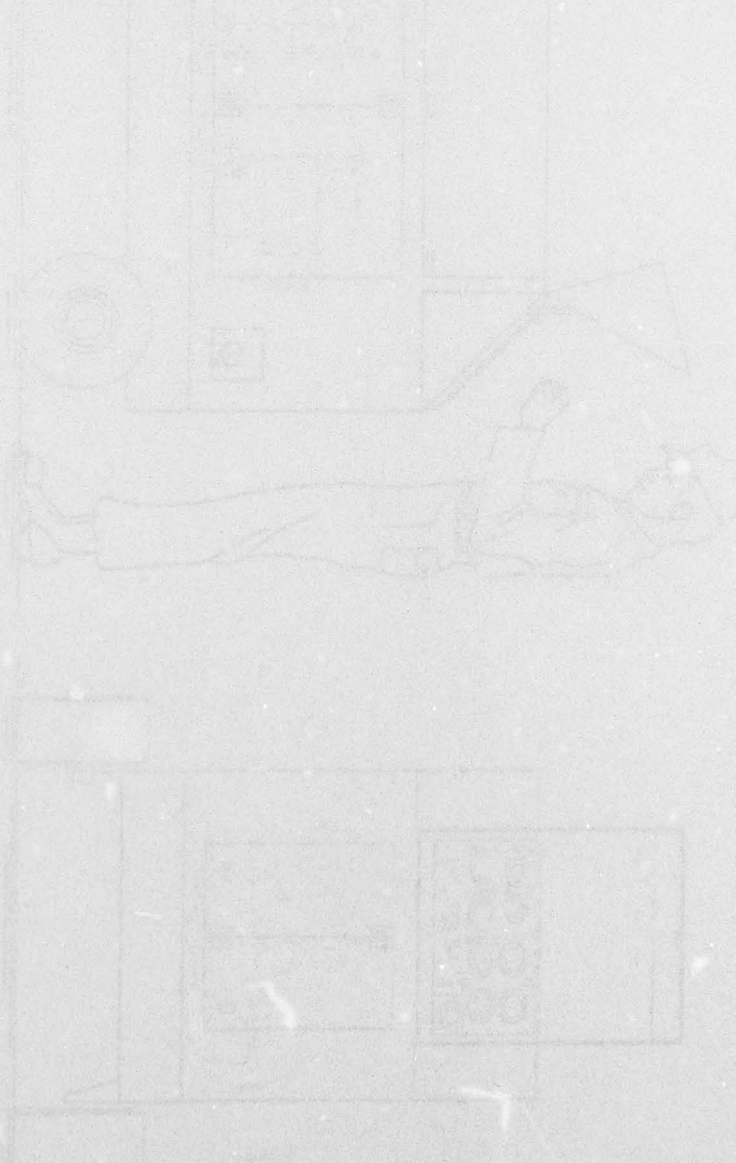

Figure 2. U.S. Army advanced ground power unit.

Utilizing available technology, and sized for the application rather than selected off the shelf, the optimum advanced APU was determined to be an integral bleed air machine using Small Turbine Advanced Gas Generator (STAGG) derivative components, relatively higher turbine inlet temperature, and a recuperator for both acoustic and fuel consumption benefits.



## PREFACE

This report was prepared by the AiResearch Manufacturing Company of Arizona. The work was accomplished under Contract DAAJ02-76-C-0042 with the Eustis Directorate, U. S. Army Air Mobility Research and Development Laboratory,\*Ft. Eustis, Va. Mr. R. R. Mejdrich directed the program for AiResearch. The Contracting Officer's Technical Representative (COTR) was Mr. R. L. Campbell, Sr.

The author wishes to acknowledge contributions made to this program by the many individuals within The Garrett Corporation, particularly P. F. Bliklen, W. G. Wald, A. T. Koen, S. S. Kitaguchi, and A. Hall.

The author also wishes to acknowledge the contribution made to this program by the following companies: Vertol Division, Boeing Company; Bell Helicopter Textron; Hughes Helicopters; Sikorsky Aircraft; Cotta Transmission Co; Vehicle Systems Development Corp; Fluid Power Design; Williams Research Corp; Vickers Aerospace; and the Brunswick Corporation. In addition, acknowledgement is given to all companies that responded to the problem statements and provided performance, cost, and physical data on their respective equipment. The companies are listed in the appropriate section of this report.

---

\*Since the preparation of this report, the Eustis Directorate, USAAMRDL, has been redesignated Applied Technology Laboratory, U.S. Army Research and Technology Laboratories (AVRADCOM).

## TABLE OF CONTENTS

	<u>Page</u>
SUMMARY . . . . .	3
PREFACE . . . . .	7
LIST OF ILLUSTRATIONS . . . . .	11
LIST OF TABLES. . . . .	13
1.0 INTRODUCTION . . . . .	15
1.1 Background. . . . .	15
1.1.1 Pneumatic Requirements . . . . .	15
1.1.2 Hydraulic Requirements . . . . .	15
1.1.3 Electrical Requirements. . . . .	15
1.1.4 Limitations. . . . .	15
1.2 Program Objectives. . . . .	16
2.0 CONCEPT FORMULATION. . . . .	19
2.1 Review Contract Statement of Work . . . . .	19
2.1.1 Specific Requirements. . . . .	19
2.1.2 General Requirements . . . . .	24
2.2 Review Existing Equipment . . . . .	25
2.2.1 MSU-1. . . . .	25
2.2.2 MA-1A. . . . .	26
2.2.3 D5-B . . . . .	26
2.3 Review Aircraft Requirements. . . . .	26
2.3.1 Helicopter Interface . . . . .	27
2.3.2 Helicopter Components. . . . .	32
2.3.3 Ground Service Requirements. . . . .	32
2.3.4 Mobility . . . . .	32
2.3.5 General. . . . .	34
2.4 Component Survey. . . . .	35
2.4.1 Prime Mover. . . . .	35
2.4.2 Hydraulic System . . . . .	37
2.4.3 Electrical System. . . . .	39
2.4.4 Mobility . . . . .	42
2.4.5 Enclosure. . . . .	47

TABLE OF CONTENTS (Contd)

	<u>Page</u>
2.5 Start System . . . . .	48
2.5.1 Electric Starting System. . . . .	51
2.5.2 Hydraulic . . . . .	51
2.5.3 Pneumatic . . . . .	51
2.6 Design Layout. . . . .	51
2.7 Summary. . . . .	59
3.0 CONCEPT SELECTION . . . . .	64
3.1 Trade-Off Technique. . . . .	64
3.2 Detailed Trade-Off Analyses. . . . .	65
3.2.1 Hydraulic Pump. . . . .	65
3.2.2 Start System. . . . .	67
3.2.3 400 Hz Electrical System. . . . .	67
3.2.4 Battery Charge System . . . . .	78
3.2.5 60 Hz System. . . . .	79
3.2.6 Enclosure . . . . .	82
3.2.7 Mobility . . . . .	92
3.2.8 Prime Mover . . . . .	94
3.2.9 Auxiliary Gearbox . . . . .	96
3.2.10 Installation. . . . .	97
3.2.11 Instrument Panel. . . . .	107
3.2.12 Acoustics . . . . .	109
3.2.13 Infrared. . . . .	113
3.2.14 GPU Selection . . . . .	115
4.0 TRADE-OFF FOR CURRENT AIRCRAFT. . . . .	127
4.1 Review Current Aircraft Requirements . . . . .	127
4.1.1 UH-1. . . . .	129
4.1.2 AH-1. . . . .	129
4.1.3 CH-47B/C. . . . .	129
4.1.4 CH-47D. . . . .	130
4.1.5 OV-1. . . . .	130
4.1.6 U-21. . . . .	130
4.1.7 CH-54 . . . . .	131
4.2 GPU System Modifications . . . . .	131
4.2.1 Electric System . . . . .	131
4.2.2 Hydraulic System Modifications. . . . .	133

TABLE OF CONTENTS (Contd)

	<u>Page</u>
4.3 Recommended Concept . . . . .	133
4.4 Program Review . . . . .	133
5.0 DESIGN OPTIMIZATION. . . . .	141
5.1 Specification of Equipment. . . . .	141
5.1.1 Wheel Drive. . . . .	141
5.1.2 Hydraulic System . . . . .	142
5.1.3 Battery Charger. . . . .	146
5.1.4 Running Gear . . . . .	146
5.1.5 Inlet Filter . . . . .	147
5.1.6 Noise Characteristics. . . . .	147
5.2 Design Layout . . . . .	148
6.0 ADVANCED APU . . . . .	165
6.1 Parametric Analysis . . . . .	165
6.2 Preliminary System Selection. . . . .	166
6.3 Final Systems Analysis . . . . .	175
7.0 CONCLUSIONS AND RECOMMENDATIONS. . . . .	184
 APPENDIXES	
A. Questionnaires. . . . .	186
B. Problem Statement -- 400-Hz System. . . . .	190
C. Problem Statement -- 60-Hz Power Supply . . . . .	190

## LIST OF ILLUSTRATIONS

<u>Figure</u>		<u>Page</u>
1	Ground power unit system trade-off tree. . . .	4
2	U.S. Army advanced ground power unit . . . . .	5
3	Program plan flow chart. . . . .	17
4	60 Hz system description . . . . .	44
5	GPU as UTTAS internal cargo. . . . .	46
6	Baseline GPU layout. . . . .	55
7	Baseline GPU . . . . .	57
8	Center of gravity location . . . . .	60
9	Electrical start system. . . . .	72
10	Pneumatic start system . . . . .	73
11	Hydraulic start system . . . . .	74
12	Candidate battery charging system. . . . .	80
13	Enclosure materials. . . . .	85
14	Exploded view of GPU body. . . . .	86
15	Fuel tank details. . . . .	88
16	Enclosure details. . . . .	89
17	Removable top details. . . . .	90
18	Two pad auxiliary gearbox, advanced ground power unit . . . . .	99
19	Clutch driven two pad auxiliary gearbox. . . .	101
20	Inertial inlet air filter diagram. . . . .	106
21	Airflow schematic, Army advanced GPU . . . . .	108
22	Instrument panel layout. . . . .	110
23	Comparative noise characteristics. . . . .	111
24	Comparative noise characteristics. . . . .	112
25	Acoustic treatment cost and weight penalties .	114
26	Infrared signature . . . . .	116
27	Cargo area and tie-down fittings . . . . .	119
28	Cargo tie-down fitting data. . . . .	120
29	GPU electrical system schematic - elementary .	121
30	Pressurized reservoir system . . . . .	122
31	Ground power unit, recommended configuration .	125
32	Ground power unit, DC output for current fleet aircraft . . . . .	135
33	Alternate GPU electrical systems . . . . .	137
34	Recommended multi-application GPU hydraulic system . . . . .	138
35	Selected ground power unit, hydraulic schematic. . . . .	143
36	Estimated GPU noise level characteristics. . .	149
37	Estimated GPU noise level characteristics. . .	150
38	Selected ground power unit, components list. .	151
39	Selected ground power unit, left side cutaway view . . . . .	153
40	Selected ground power unit, section view . . .	155
41	Selected ground power unit, end view . . . . .	157

LIST OF ILLUSTRATIONS (Contd.)

<u>Figure</u>		<u>Page</u>
42	Selected ground power unit, right side installation view . . . . .	158
43	Selected ground power unit, final instrument and control panel . . . . .	159
44	Selected ground power unit, AC circuit wiring schematic. . . . .	161
45	Selected ground power unit, DC circuit wiring schematic. . . . .	163
46	Nonrecuperated engine with load compressor. .	167
47	Recuperated engine with load compressor . . .	168
48	Recuperated engine with load compressor . . .	169
49	Recuperated engine with load compressor . . .	170
50	Recuperated engine with load compressor . . .	171
51	Interstage bleed APU, parametric analysis . .	173
52	Recuperator sizing study. . . . .	176
53	Recuperator sizing study. . . . .	177
54	Predicted acoustics for advanced APU. . . . .	180

LIST OF TABLES

		<u>Page</u>
1	Aircraft System Characteristics . . . . .	28
2	Helicopter Interfaces . . . . .	31
3	Tabulation of Aircraft Hardware . . . . .	33
4	Subsystem Requirements. . . . .	36
5	Power Plant Characteristics . . . . .	38
6	60 Hz Power Supply Characteristics. . . . .	43
7	APU Starting Characteristics. . . . .	49
8	GPU Estimated Weight. . . . .	53
9	GPU Weight Breakdown. . . . .	61
10	Power Generation System Matrix. . . . .	62
11	Hydraulic Pump Characteristics. . . . .	66
12	Boeing 747 1976 Hydraulic Pump U.R. Summary . . . .	68
13	L-1011 Hydraulic Pump Reliability Summary . . . .	69
14	Boeing 707/727/737 1976 Hydraulic Pump U.R. . . .	70
	Summary . . . . .	
15	Hydraulic Pump Tradeoff . . . . .	71
16	Starting System Trade-Off . . . . .	75
17	20 KVA Electrical Generating System . . . . .	77
18	60 Hz Power Trade-Off . . . . .	83
19	Mobility Equipment. . . . .	95
20	Installation Parametric Analysis. . . . .	104
21	Ground Power Unit Trade-Off . . . . .	117
22	Existing Aircraft Ground Power Requirements . . . .	128
23	Changes to Fit Existing Aircraft. . . . .	132
24	Comparison of Integral Bleed Engines. . . . .	172
25	Maximum Power APU Comparison at 10,000. . . . .	
	Feet, 64°F. . . . .	174
26	Recuperator/Acoustic Treatment Trade-Off Engines .	178
27	Volume Comparisons. . . . .	179
28	Muffler Volumes - Ft <sup>3</sup> . . . . .	181
29	Recuperator Volumes - Ft <sup>3</sup> . . . . .	181
30	Weight Analysis . . . . .	182

## 1.0 INTRODUCTION

### 1.1 Background

This document summarizes an analysis defining an advanced ground power unit (GPU) to provide service for the Advanced Attack Helicopter (AAH), the Utility Tactical Transport Aircraft System (UTTAS), and CH-47D helicopter. Present APU-equipped Army aircraft have up to a 2:1 APU-to-aircraft-hour utilization ratio. With increasingly sophisticated electronic gear on aircraft such as the AAH, this ratio could become even higher, resulting in degraded aircraft availability due to high onboard APU usage.

Using the GPU for all maintenance and extended running, the on-board APU life would be optimized for mandatory aircraft pre-/post-flight checkout and main engine starts (MES). An additional benefit gained from using the multioutput GPU is in the reduction of the total amount and variety of ground support equipment.

#### 1.1.1 Pneumatic Requirements

No pneumatic supply carts are presently available in Army inventory. AAH and UTTAS flight test evaluation trials were conducted using surplus MA-1A Air Force carts; current Air Force production units are A/M32A-60. Both MA-1A and A/M32A-60 carts are significantly larger than required to service these Army aircraft.

#### 1.1.2 Hydraulic Requirements

Hydraulic system needs are presently filled by MSU-1 or D5-B/C carts. The MSU-1 is heavy and expensive, and has demonstrated poor reliability. The D5-C is a lighter weight unit, but supplies only hydraulic services and will not meet reservoir contamination requirements of current aircraft systems.

#### 1.1.3 Electrical Requirements

Electric supply can be provided by the MSU-1 or the DOD standard 30-KW, 400-Hz diesel-driven generators. However, these sets are heavy and have poor reliability, and neither will meet GPU mobility requirements.

#### 1.1.4 Limitations

All of the existing equipment includes one or more of the following limitations:

- (a) Limited in application (single or dual services)
- (b) High weight
- (c) Poor reliability
- (d) Poor mobility
- (e) High cost

The advanced GPU defined by this study overcomes these limitations and provides a lightweight, compact source of pneumatic, electric, and hydraulic power in a highly mobile, cost-effective, reliable, and easily maintained package.

## 1.2 Program Objectives

The advanced GPU program was conducted according to the plan presented in the sections that follow and as shown graphically by Figure 3.

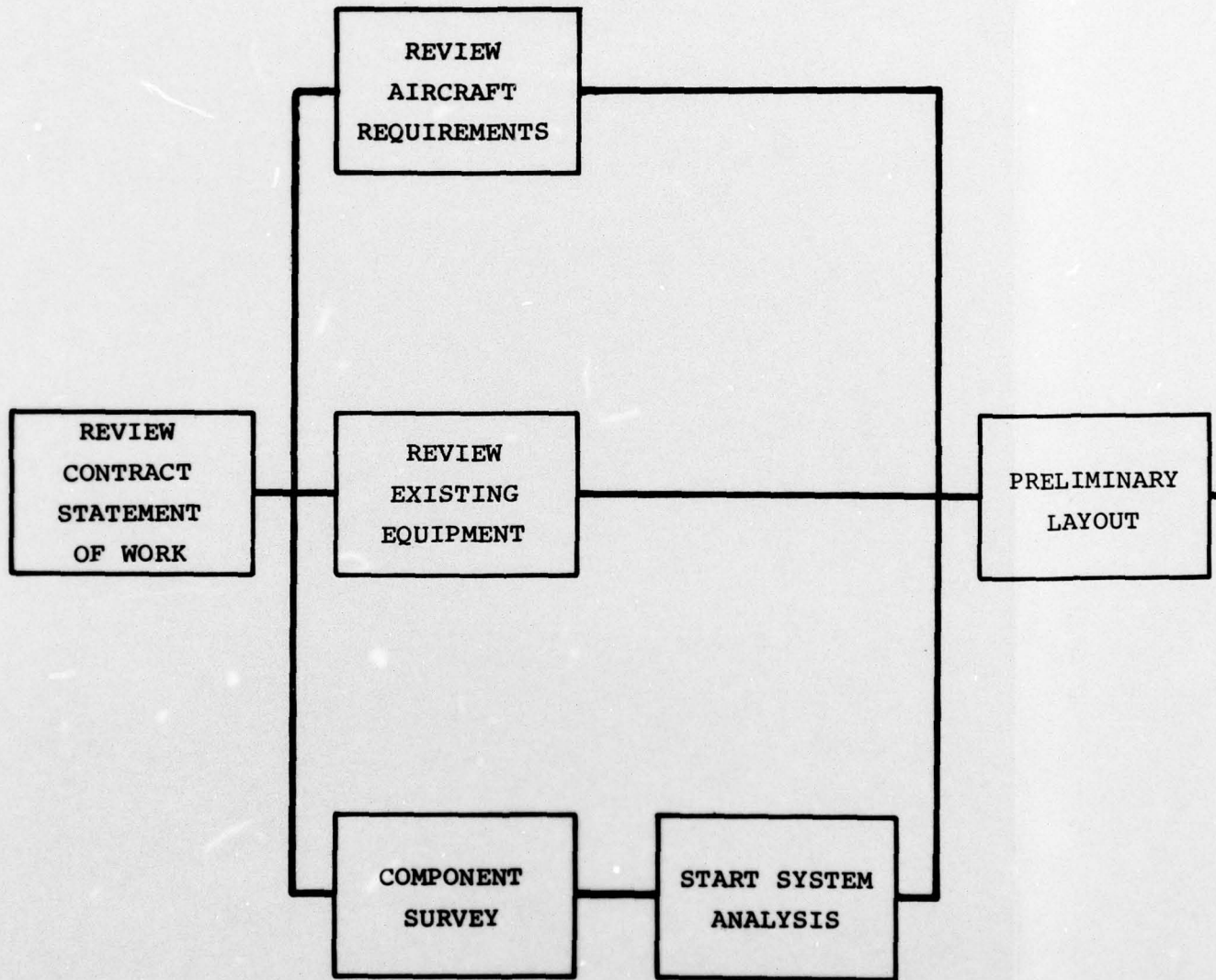

Figure 3. Program Plan Flow Chart.

ESTABLISH  
WEIGHTING  
FACTORS AND  
TRADE-OFF  
TECHNIQUES

ESTABLISH  
SUBSYSTEM/  
COMPONENT  
MATRIX

ESTABLISH  
VIABLE GPU  
CANDIDATES

PERFORM  
IN-DEPTH  
TRADE OFF  
ANALYSIS

SELE  
SYST

PRELIMINARY  
LAYOUT

PRELIMINARY  
SCREENING

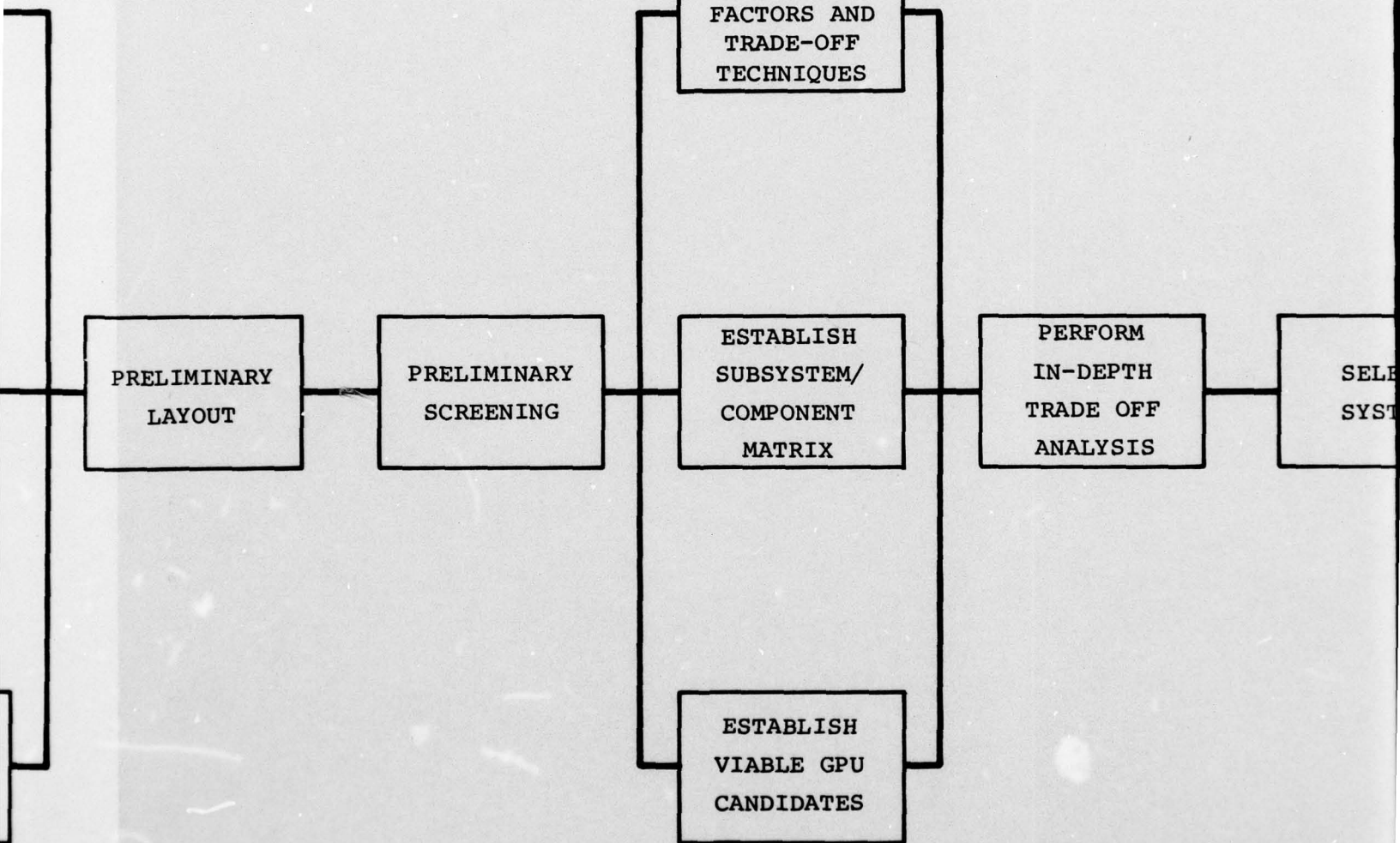

2



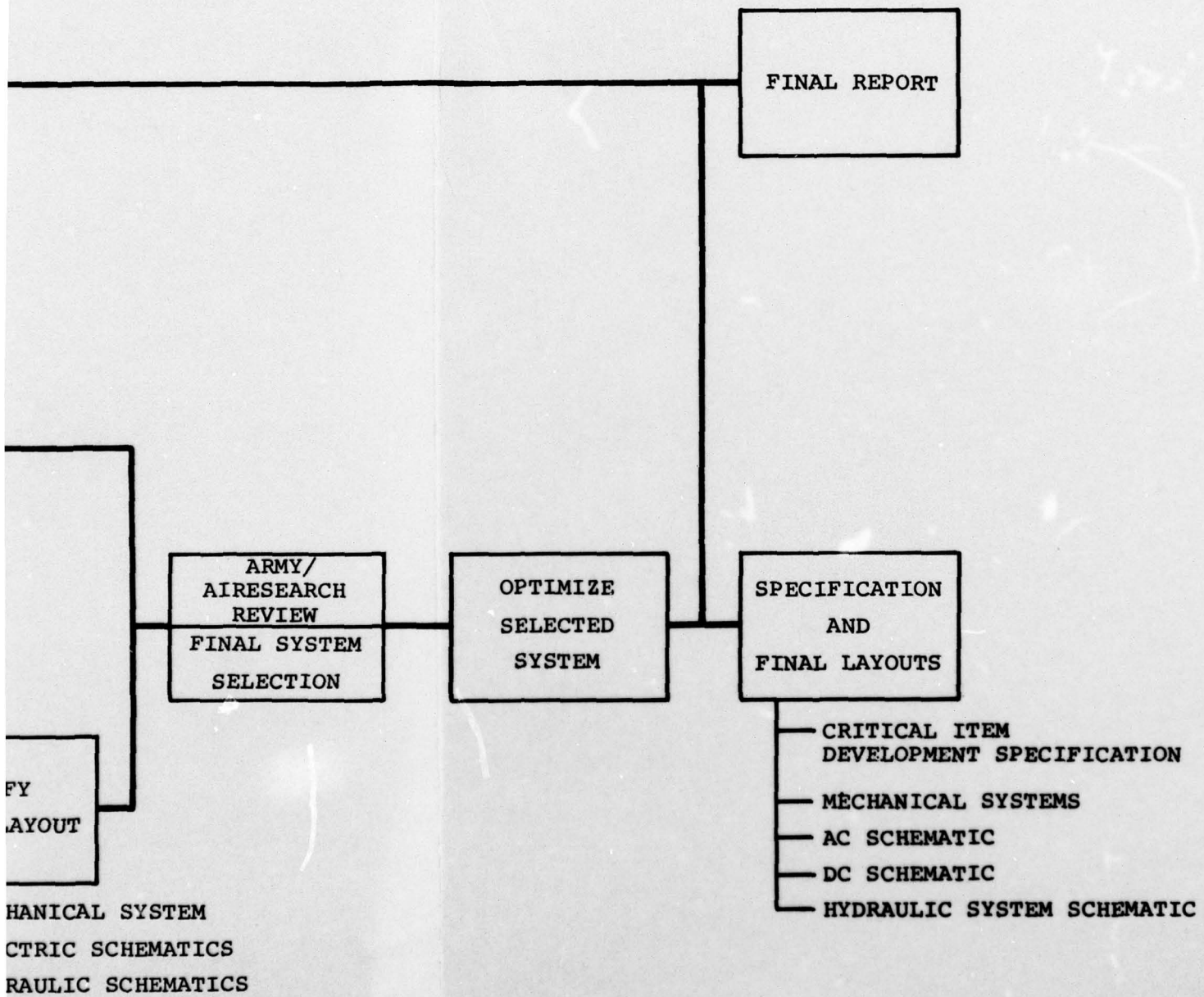

## 2.0 CONCEPT FORMULATION

The concept formulation task was comprised of defining general portions of the contract Statement of Work (SOW), verifying specific requirements, and gathering component data and ideas from which to form the GPU concepts to be evaluated in subsequent tasks.

### 2.1 Review Contract Statement of Work

The contract SOW was a composite of specific and general requirements. Specific requirements were those defining GPU performance. General requirements included all design details by which specific GPU performance characteristics were determined, such as noise, mobility, enclosure, design and materials, component arrangements, and size. From a review of the contract SOW with the Government, three additional requirements were established:

- (a) The GPU should be capable of highway tow at speeds up to 25 mph.
- (b) The GPU should be towable by the M151, 1/4-ton truck in addition to the M-37 and M-34 trucks.
- (c) Hydraulic system considerations for the analysis of Section 4 should include 3 micron filtration for the CH-47D. It was also requested that output flow for the CH-47D should be 29 gpm at 3000 psi; however, this subsequently proved to be erroneous and the SOW requirement of 15 gpm was determined to be adequate.

The SOW requirements on which the study was based are summarized in the paragraphs that follow.

#### 2.1.1 Specific Requirements

The GPU shall provide electrical, hydraulic, and pneumatic power, either individually, in dual combination, or all three simultaneously to meet the minimum ground power requirements for the Advanced Attack Helicopter (AAH) and/or the Utility Tactical Transport Aircraft System (UTTAS). Subsystem power generation shall include integral, automatic, power output controls for frequency, pressures, and flows.

(a) Fuel Supply - The GPU design shall contain an integral fuel supply with a usable fuel capacity for 2 hours of GPU operation at maximum power output without refueling. Fuel tank drainage capability shall be provided.

(b) Power Plant and Drive Subsystem - The GPU power plant and power generation drive subsystem shall be designed to include the following:

(1) The GPU power plant shall be essentially constant speed and shall not, upon being subjected to transients in GPU output power, droop or fluctuate in speed causing output power to fall outside limits contained in the paragraphs that follow.

(2) The power plant shall operate on fuel conforming to MIL-T-5624, Grade JP-4 or JP-5.

(3) The GPU power plant and drive system shall contain an integral lubrication system and shall be operable on oil conforming to MIL-L-7808 or MIL-L-23699.

(4) The GPU shall have an integral power plant starting system with the capability of a second start attempt if the first is not successful. The starting system shall automatically recharge during GPU operation. A backup manual, or other external source, starting system recharge capability shall be incorporated.

(c) Electrical Power Subsystem - The GPU electrical power generation subsystem shall:

(1) Produce 120/208-vac, three-phase, 400-Hz power with up to a 20-KVA output capability. Frequency, voltage, and phasing shall be regulated by an integral, automatic monitor and control unit.

(2) Provide signal conditioning to produce 115-vac, 60-Hz power at an environmentally protected outlet on the GPU.

(3) Provide an ac power output cable with an end connection conforming to MS25486.

- (4) Conform to the power quality requirements of MIL-STD-704A, Category B.
  - (5) Not create electromagnetic interference with the subsystems of the aircraft to which the GPU is applied.
  - (6) Contain controls for manual subsystem power flow shutoff in the event of subsystem malfunction.
- (d) Hydraulic Power Subsystem - The GPU hydraulic power generation subsystem shall:
- (1) Produce 3000-psig hydraulic pressure with a minimum flow rate of 15 gpm.
  - (2) Incorporate relief and by-passing valves for excess pressure control and returning excess fluid flow to the GPU hydraulic reservoir.
  - (3) Contain an integral fluid reservoir conforming to MIL-R-8931, fluid cooling, and conform to temperature and aeration prevention requirements of MIL-H-5440F, Type II systems.
  - (4) Be operable on MIL-H-5606 or MIL-H-83282 hydraulic fluid (MIL-H-5606 only below -40°F).
  - (5) Contain a 5-micron absolute fluid filter and subsystem draining and purging capability. For the Section 4 analysis, a 3-micron filtration level is required.
  - (6) Provide a power output hose with a quick disconnect end connector conforming to self-sealing requirements of MIL-H-5440F.
  - (7) Contain controls for manual subsystem power flow shutoff in the event of subsystem malfunction.
- (e) Pneumatic Power Subsystem - The GPU pneumatic power generation subsystem shall be designed to:

- (h) Ground and Air Mobility - The GPU shall have the following ground and air mobility characteristics and capabilities (items 1 through 4 apply only if the GPU configuration has wheels):
- (1) The GPU shall have integral tow fittings, steering, and ground flotation capability to permit towing and movement at up to 2 miles per hour by, as a minimum, an M-37 3/4-ton, an M-34 2-1/2 ton, or an M-151 1/4-ton cargo truck in rough unimproved terrain. Rough, unimproved terrain is defined as a land surface area sufficiently free of standing vegetation to permit helicopter flight operations (landing and takeoff) and having no prior surface preparation; a soil strength as low as a one-pass Cone Index of 50 combined with up to 3-percent (2 degrees) slopes, graduating to a one-pass Cone Index of 125 combined with a slope of up to 27-percent (15 degrees); surface depressions or protrusions of 6 in. vertically and 6 in. wide, with horizontal spacing between such depressions/projections of as close as 10 feet.
  - (2) The GPU towbar shall have a lunette eye conforming to MS51336.
  - (3) The GPU shall have a turning radius of not more than 18 feet, and shall have an integral, manual brake to prevent inadvertent movement on a 27-percent (15 degree) slope.
  - (4) The GPU shall be towable at speeds up to 25 mph on improved roads.
  - (5) The GPU shall be air transportable by UH-1H, UTTAS, CH-47, CH-54, and C-130 aircraft. The GPU shall have integral sling attachment points above the center of gravity and shall not require GPU configuration modification to be airmobile as a helicopter sling load or as internal cargo in the above fixed-wing aircraft.
- (i) Operational Attitude - The GPU shall be operational on up to 27-percent (15 degrees from horizontal) slopes when parked in any GPU azimuth on such slopes.

- (j) Output Lines - The GPU output parameter hoses, lines, and/or leads, with appropriate connectors for aircraft attachment, shall not be less than 30 feet long.
- (k) Reliability, Maintainability and Human Factors - The GPU shall have a minimum service life of 5000 hours, a functional mean-time-between-failures of at least 500 hours, and an on-condition component overhaul policy. The GPU shall retain output capability of the remaining parameters if one output mode (e.g., hydraulic) is inoperative. The GPU shall not pose undue hazards to operator or crew.

#### 2.1.2 General Requirements

Perform a concept formulation, selection, and design layout of an experimental model advanced technology, multi-parameter output GPU for use on Army developmental helicopters (AAH and UTTAS). The GPU shall, as a minimum, be designed to provide power outputs defined herein when operated in the defined environment, possess the air and ground mobility characteristics set forth, and be significantly lighter and more compact than current inventory power units. The GPU and GPU systems shall be compatible with comparable systems on board the aircraft which it services.

In performing this effort, consider:

- (a) Use of late-technology, flight-qualified electrical and hydraulic power generators and subsystem components to minimize weight and increase compactness.
- (b) Use of late-technology GPU subsystem components which are common to, and interchangeable with, counterpart components and assemblies on the aircraft serviced by the GPU to yield logistics simplifications via commonality.
- (c) Use of a late-technology, off-the-shelf, gas turbine APU having compressor bleed air capability to provide required pneumatic power outputs.
- (d) Use of a derated engine to provide increased GPU reliability and service life.
- (e) Use of high flotation wheels and tires to provide the required rough terrain mobility.

- (f) Use of lightweight, high-strength materials, such as titanium, aluminum and composites, in GPU framing and structural members to minimize weight.
- (g) Use of stored-energy electrical, hydraulic, or pneumatic GPU power plant starting systems.
- (h) Incorporation of a device to reduce GPU power plant foreign object damage and internal erosion due to sand and dust.
- (i) Use of wheels versus skids for effect on mobility.
- (j) As an objective, an operational GPU noise level of no more than 50 dB at 10 feet on any horizontal azimuth from the GPU.
- (k) A design as simple as possible for maximum inherent reliability and maintainability.
- (l) Modular design for rapid GPU repair.

## 2.2 Review Existing Equipment

To provide a basis for comparison of the new design, existing equipment used to service the aircraft in the AAH and UTTAS aircraft competitive fly-off was reviewed. This review provided a significant input to the design study, which showed the lack of adequate servicing equipment in present Army inventory to meet requirements. Equipment used consisted of the Army MSU-1, Air Force surplus MA-1A, and the Army D5-B hydraulic cart. Although each of these carts provided part of the output required, none provided all. The equipment used was heavy, bulky, exhibited poor reliability, and generally limited usefulness for its intended task.

### 2.2.1 MSU-1

The MSU-1 was a diesel-engine-driven combination electric and hydraulic servicing cart primarily intended for shipboard use and was originally developed under Navy Bureau of Weapons (BUWEPS) auspices by Sun Electric Company. Cart outputs are hydraulic and electric (both ac and dc). The MSU-1 is self-propelled. Disadvantages of the MSU-1 were high weight, bulkiness, poor reliability (particularly in starting) and a limited output capability due to the diesel engine power level. Human factor characteristics of the MSU were poor. The instrument panel was cluttered and difficult to read. The unit was noisy since there was no attenuation of body radiated noise from

either the diesel engine or hydraulic pump. In addition, the unit displayed all normal problems of diesel-engine-driven equipment such as frequent maintenance requirements for the belts, hoses, and fuel injection system components, requirement for ether-assist starting at any temperature below 70°F, and difficult servicing due to the packaging arrangement, size, and weight of components involved. Availability of the MSU was significantly compromised by the hydraulic engine start system. The backup arrangement provided either an external connection for a buddy start or a hand pump to recharge the accumulator. In many cases, the hand pump was the only backup available. Good features of the MSU-1 included the self propulsion feature, the hydraulic system flexibility allowing operation from either the aircraft or MSU reservoir, and the stowage hooks allowing interim ready storage of the service conductors.

#### 2.2.2 MA-1A

This cart was developed by AiResearch for the USAF in 1955 and was the USAF standard air start cart through the early 1970's. Approximately 3000 MA-1As were produced in that period. The MA-1A successfully served its intended purpose, i.e., air starting the USAF Strategic Air Command (SAC) fleet of B-47 and B-52 bombers. Its disadvantages for servicing the AAH and UTTAS were based on the fact that it is a pneumatic supply only and had about twice the required capacity for the helicopter application.

#### 2.2.3 D5-B

The D5-B was used by at least one of the AAH contractors due to an inability to get the MSU-1 to operate. The D5-B provided a hydraulic test capability, but it was limited in application due to its single output.

### 2.3 Review Aircraft Requirements

As a further aid in establishing the study basis and also in verification of the SOW, an effort was made to review aircraft requirements. It was felt that this review would be best accomplished by a visit to the aircraft manufacturers facilities. Tasks described in Paras. 2.2 and 2.4 were also addressed during these visits.

Prior to the visits to the airframe manufacturers in August and September 1976, a letter requesting the visit and presenting a preliminary questionnaire was sent to each of the potential aircraft manufacturers: Hughes and Bell for AAH, and

Vertol and Sikorsky for UTTAS. Recognizing the competitive nature of the aircraft programs at this time, a means was sought to protect any responses that could compromise the airframe manufacturers competitive position. If properly identified, it was found that certain material could be exempted from distribution under the Public Information Act. Throughout the program, all data that was felt to be sensitive in nature was stamped "Competition Sensitive," and all documents reporting this information carried the legend, "This page/report contains proprietary technical information exempt from freedom of information distribution per 18 USC 1905."

The questionnaire (Appendix A) sent to the airframe manufacturers requested general information dealing with:

- o Aircraft interface
- o Number, type, and description of ground service connections
- o Amount and type of input power required
- o Required power quality
- o Any general information which might assist designing the GPU for aircraft compatibility

Prior to the actual visits, a second list was prepared dealing with more specific information including component details such as vendor name, part number, capacity, direction of rotation, etc. This list dealt primarily with the component commonality aspect of the program.

Results of the visits were favorable. Responses generally exceeded expectation. However, one airframe manufacturer felt that the information requested was of a proprietary nature and provided no immediate response to the questions submitted. This led to problems in the final hydraulic system configuration which will be discussed in Paragraph 5.1.2.

Results of the aircraft review are shown in Table 1.

### 2.3.1 Helicopter Interface

For purposes of this study, the helicopter interface was interpreted to include compatibility with the onboard systems as well as physical ground service attachments on the aircraft skin. Three basic system interfaces, the electrical, hydraulic

TABLE 1. AIRCRAFT SYSTEM CHARACTERISTICS

Aircraft	Electric	Hydraulic	Pneumatic	Installation
A	<p>Alternator - 20 KVA 400 Hz Air Cooled - 12,000 Rpm - CCW Looking at Anti-Drive End</p> <p>Battery AC Power Monitor MS24021-2 TR Unit 100 Amp</p>	<p>Pump - 300 Psi - 12 Gpm 8016 Rpm 0.38 CIDR</p> <p>Cooler Accumulator Initiator Valve (Start Solenoid) Reservoir System Uses Individual Components</p>	<p>Integral APU Bleed for MES and ECS</p>	<p>-65° to 160°F Nonoperating -65° to 126°F Operating S.L. to 15,000 Ft Operating 20/30 Kva, 400 Hz, 6 kW, 28 Vdc 3000 Psi, 20 Gpm; 80 lb/min at 55 psia 400°F Bleed Air; MIL-STD-704A Electric Power Quality No Parallel With A/C Systems Follow-up Response for Balance of Information not Received</p>
B	<p>Alternator - 20 KVA 400 Hz Air Cooled - 12,000 Rpm</p> <p>AC Power Monitor - MS24021-2 TR Unit Battery - Lead Acid - 17 Amp-Hr.</p>	<p>Pump - 3000 Psi, 4 Gpm Cooler Accumulator 250 In.<sup>3</sup> Initiator Valve - Built into Accumulator System Uses Individual Components</p>	<p>Load Compressor Load Valve Air Pressure Regulator</p>	<p>-65° to 125°F Operating S.L. to 12,000 Ft. Frequency Control to MIL-E-24021F Power Quality to MIL-STD-704B 20 Kva, 400 Hz; 3000 Psi, 10 Gpm 32 Lb/Min at 45 Psia (Reg)</p>
C	<p>(1) Alternator - 30/45 KVA 400 Hz Oil Spray Cooled 12,000 Rpm</p> <p>AC Power Monitor MS24021-2 Battery</p>	<p>System Uses Pump, Cooler, Reservoir Module - Approx 6 Gpm Capacity</p>	<p>Integral APU Bleed for MES and ECS</p>	<p>No data</p>
D	<p>Alternator - 40 KVA, 400 Hz Oil Cooled 12,000 Rpm</p> <p>AC Power Monitor Battery 6 Amp-Hr. NiCad TR Unit Cond Monitor (Integrated With Battery)</p>	<p>Pump/Cooler/Fan Module 7 Gpm - 3000 Psi Accumulator - 300 In.<sup>3</sup> Initiator Valve</p>	<p>Integral APU Bleed for MES and ECS</p>	<p>-65° to 125°F S.L. to 15,000 Ft MIL-STD-704B 115 V 60 Hz Provided by Optional NSN Converter</p>

(1) Model C also uses a 20-KVA 400-Hz, 12,000-rpm air-cooled alternator for the APU only

and pneumatic, were required. Because the ultimate manufacturers of the AAH and UTTAS helicopters had not been selected at the time the study was initiated, GPU compatibility with the three basic interfaces was complicated by the fact that there were essentially four aircraft models involved.

#### 2.3.1.1 Electrical Interface

The electrical interface connector on prototype helicopters conformed to MS90362-4. Originally, an MS24586-1 connection was also planned for use on the Hughes AAH. However, it was subsequently deleted so that all aircraft were consistent and compatible with standard hardware. The Hughes YAH-64 also has an AN2552 28-vdc connector which, though not required for normal operation, was provided for convenience.

All the prototype aircraft models also used an external power monitor conforming with MS24021-2 which compared input power quality with the requirements of MIL-STD-704A. If the external supply was noncompliant, the monitor would reject it by opening the aircraft external power relay. Input power features checked by the external power monitor included frequency, voltage, and phase sequence. The external power monitor was arranged to provide its own dc supply by converting external ac, thus allowing an external power connection even with low or dead aircraft batteries, or with the aircraft battery removed.

The ac power generating capability provided on the aircraft was relatively consistent. Three of the four aircraft models used a version of the Bendix Model 28B262 20-KVA, 400-Hz, 12,000-rpm air-cooled alternator. Different dash numbers were used to represent different directions of rotation and detail design features to fit requirements of the specific application.

A Lucas 30/45-KVA, oil-cooled 12,000-rpm machine was used on one aircraft model.

The alternators were driven directly from the onboard APU output, or from the aircraft accessory drive gearbox. One aircraft employed two different part number alternators: a 30/45 KVA, oil-cooled, 12,000-rpm unit constant-speed-driven for the main aircraft supply, and the Bendix 20-KVA unit previously mentioned, which was APU-driven.

The generator control units (GCUs) used in each case were matched to, and procured as a set with, the alternator.

Direct current systems varied considerably on the aircraft. None of the aircraft required external dc power supply for normal operation although some did make provision for external dc input. All four aircraft models included storage batteries, primarily for instruments and control, since each employed hydraulic APU starting. All the aircraft used NiCad batteries varying in size from 6 to 22 ampere-hour capacity. These batteries employed charging systems ranging from simple transformer-rectifier (TR) units to very sophisticated battery condition monitor and charging systems which maintained and advised battery condition through cockpit indicators on a continuous basis.

#### 2.3.1.2 Hydraulic Interface

The aircraft hydraulic interface was represented by two ground service hydraulic quick-disconnect attachments. These varied in size from -8 (1/2 in.) per MIL-H-8790 for the pressure supply to -12 (3/4 in.) for the system return. Generally, two sets of attachments were provided: one for the flight control and one for the utility hydraulic systems. System flow requirements varied from 4 gpm to 12 gpm at 3000 psi. Both UTTAS models also used 3000 psi systems in the flow range of 6 to 7 gpm. Both vented and pressurized reservoir systems were utilized, and systems were comprised of individual and modular components. Hydraulic modules included the pump, cooler, fan, filters, and bypass and relief valves. Use of the modules was intended to enhance system maintainability. However, the modularized cost was two to three times that of individual components.

#### 2.3.1.3 Pneumatic Interface

The aircraft pneumatic interface allowing ground service connection for Environmental Control System (ECS) operation and main engine starts (MES) was a nipple conforming to MS33740. Three of the four aircraft models used onboard APUs having integral bleed capability. The Hughes AAH used a shaft-driven compressor (SDC) taken off the accessory drive gearbox in the helicopter. Since the Hughes AAH systems were designed for a bleed air pressure of 30 psig, the application of higher pressure caused some matching problems. As a result, Hughes initially suggested installing a bleed air pressure regulator in the GPU to limit pressure to a level compatible with the aircraft equipment. However, this was later found to be unnecessary since an internal pressure regulating device (blow off valve) had been incorporated into the aircraft.

A summary of the helicopter interfaces is presented in Table 2.

TABLE 2. HELICOPTER INTERFACES

Aircraft	Electric	Hydraulic	Pneumatic
A	MS90362 Receptable MS24021-2 Power Monitor No dc No 60 Hz	Not Fixed	MS33740 Nipple
B	AN3114-2A Receptacle MS24435 Utility Receptacle 28 Vdc No 60 Hz	MIL-H-5440 -12 Pressure, -16 Return Could Use -8, 12	MS33740 Nipple
C	MS90362-4	QAD Fittings	MS33740 Nipple
D	MS25486 End Connection No dc No 60 Hz	-12 Pressure, -16 Return Aeroquip 3200 Series QAD Increased for MIL-H-5440 from -6, -8	MS33740 Nipple

### 2.3.2 Helicopter Components

Since one of the desirable GPU system characteristics was commonality with aircraft components, systems, and subsystems, a tabulation of these items was made during the visits to the airframe manufacturers.

Components listed included the APU, alternator and regulator, hydraulic pump, battery, start accumulator, start motor, start initiator valve, hydraulic reservoir, battery, battery charger/condition monitor, and any other equipment used on the aircraft which might have been applicable to the GPU. This listing is shown in Table 3.

Generally, it appeared that aircraft APU, generator, and possibly start system components, might have been useful in the GPU. Because of smaller capacity or complexity, aircraft hydraulic system components were not useful.

### 2.3.3 Ground Service Requirements

In addition to helicopter system descriptions and identification of components by part number, it was recognized that, in some cases, ground service requirements might be in excess of those provided by the onboard APU. This possibility was addressed in the questionnaire sent to the aircraft manufacturers. Responses generally indicated duplication of onboard APU performance requirements/capabilities except for the Bell AAH. Bell ground service requirements, all well in excess of APU capabilities, were stated to include up to 30 KVA, 400 Hz and 6 KW 28 vdc, electrical; 20 gpm at 3000 psi hydraulic; and 80 lb/min at 55 psia pneumatic. It was assumed that (1) the hydraulic requirement was established to enable powering both utility and flight control systems simultaneously with maximum flow on both, and (2) the pneumatic requirement would allow both air conditioning and main engine start simultaneously. Recognizing the GPU output would at least match onboard APU output, the concept formulation was undertaken, assuming that duplicating APU output would allow adequate performance to satisfy all normal ground service requirements.

### 2.3.4 Mobility

The contract SOW specified that an evaluation be made of both skid-mounted and wheeled devices for this study. Further evaluation of intended usage of the GPU indicated that the SOW rough terrain description truly defined the potential laager area in which the GPU would be deployed. In this kind of situation, GPU usefulness would be seriously degraded if it

TABLE 3. TABULATION OF AIRCRAFT HARDWARE

Aircraft	Electric	Hydraulic	Pneumatic
A	<p>Alternator - Bendix 28B262-32 20 KVA, 400 Hz Air Cooled - 12,000 rpm - CCW Looking at Anti- Drive End</p> <p>GCU Bendix 21B17-60</p> <p>Contactator</p> <p>Battery</p> <p>A.C. Power Monitor MS24021-2</p> <p>TR Unit - Wagner Electric 28 VS 1004-16 100 amp</p>	<p>Pump - Vendor not Assigned 3000 psi - 12 gpm 8016 rpm 0.38 cidr.</p> <p>Cooler</p> <p>Accumulator</p> <p>Initiator Valve (Start Solenoid)</p> <p>Reservoir</p>	<p>Integral APU Bleed for MES and ECS</p>
B	<p>Alternator - Bendix 28B262-30 20 KVA, 400 Hz Air Cooled 12,000 rpm</p> <p>GCU Bendix 21B17-61</p> <p>CT Bendix 2B91-1</p> <p>AC Power Monitor - MS24021-2 Dynamic Controls Corp. DC10786-6</p> <p>TR Unit Bendix 9B40-10</p> <p>Battery Lead-Acid - 17 amp-hr</p>	<p>Pump - 3000 psi - 4 gpm</p> <p>Cooler</p> <p>Accumulator 250 in.<sup>3</sup></p> <p>Initiator Valve - Build into Accumulator</p>	<p>Load Compressor</p> <p>Load Valve</p>
C	<p>Alternator* Bendix 28B302-8 30/45 400 Hz Oil Spray Cooled 12,000 rpm</p> <p>GCU Bendix 21B17-55</p> <p>CT Bendix 2B103-1</p> <p>AC Power Monitor</p> <p>Contactator</p> <p>Battery</p>	<p>System Uses Pump, Cooler, Reservoir Module - Approx. 6 gpm capacity</p>	<p>Integral APU Bleed for MES and ECS</p>
D	<p>Alternator - Lucas AE2152 40 KVA - Oil cooled, 12,000 rpm</p> <p>GCU Lucas AE7083</p> <p>CT Lucas AE5795</p> <p>AC Power Monitor</p> <p>Battery 6 amp-hr NiCad-Gulton</p> <p>TR Unit SAFT EMBS-143A Cond Monitor (integrated with battery)</p> <p>Contactator - Hartman Electric B233K</p>	<p>Pump/Cooler/Fan Module - Kelsey-Hayes 7 gpm - 3000 psi</p> <p>Cooler - UAP</p> <p>Accumulator - Parker Hannifin - 300 in.<sup>3</sup></p> <p>Original Design</p> <p>Initiator Valve - Sterer Vertol P/N 179-32106-1</p>	<p>Integral APU Bleed for MES and ECS</p>

\*Model C also uses a Bendix 28B262-27, 20-KVA, 40-Hz, 12,000-rpm air-cooled alternator for the APU only.

were skid-mounted. Bolting the skid-mounted device to a trailer would not provide any significant improvement. Therefore, it was felt that the towed, wheel-mounted device was the only viable approach to the problem. This supposition was later proven in the numerical evaluation of the systems during the concept selection task. During discussions of the GPU concept with the airframe manufacturers, it was suggested that the advanced GPU should be self propelled. These suggestions were again based on anticipated usage for the equipment. Normal laager deployment would place the aircraft to be maintained at least 30 meters apart and hidden by camouflage or natural foliage. A towed device would have to be moved by another vehicle in the rough terrain conditions that could exist since the tow load could approach 500 pounds. With anticipated repair times on the order of 30 minutes to 1 hour, this would demand full-time assignment of a tow vehicle to a GPU to ensure adequate GPU utilization. For this reason, a self-propelled device was also considered. Both separate drive motors and drive devices powered by the onboard power supply were considered.

#### 2.3.5 General

Several suggestions and comments were received from the airframe manufacturers that appeared to be appropriate for consideration during the concept formulation task.

##### 2.3.5.1 Fire Protection

Because the GPU would be deployed in close proximity to the aircraft, consideration should be given to the GPU fire hazard with regard to extinguishers, contained flammable fluids, and as a potential ignition source. Since the GPU would store fuel, oil, and hydraulic fluid, care should be taken in the system design to minimize potential hazards to the aircraft. This problem was compounded since high temperature components of the GPU engine, whether gas turbine or diesel, also represented an ignition source.

##### 2.3.5.2 Infra Red

No recognition was given to GPU infra-red characteristics in the contract SOW. Although helicopter deployment, paint, and camouflage techniques were all developed to minimize unit detectability by visual or infra-red detection devices, the GPU would be operating in close proximity to the aircraft. The GPU would generate a significant infra-red signature due to power plant exhaust plume and hot metal parts associated with the system exhaust.

## 2.4 Component Survey

Since a number of the components used on the helicopters were not applicable to the GPU due to size, cost, or complexity, it was determined that an outside survey should be made to provide an adequate array of combinations to satisfy system requirements. Surveys were made to maintain commonality with aircraft hardware and provide flight qualified aircraft type hardware to minimize weight and volume.

### 2.4.1 Power Plant

The contract SOW was written specifically toward a gas turbine GPU power plant. However, with increased emphasis placed on fuel consumption and fuel economy, it was requested that the diesel engine be evaluated as a part of this study. For this reason, both gas turbine and diesel engines were considered.

#### 2.4.1.1 Gas Turbine

Each aircraft model considered in this analysis (AAH, UTTAS and CH-47D) study has an onboard gas turbine APU. Although different modes of output power extraction were employed (pure shaft or combination bleed and shaft), the aerodynamic output capability of each was over 200 shp. Since output power required for the application was only 115 shp (Table 4), it was evident that helicopter APUs would be significantly derated in the GPU application. None of the helicopter APUs exactly fit the GPU application since, ideally, the GPU power plant should be either a pure shaft machine with three output pads to drive a compressor, alternator, and hydraulic pump, or a two-pad with integral bleed. Since there was a limited number of gas turbine power plants in this power class, it was determined that the best approach would be to survey available power units and try to make an optimal selection from the available hardware.

Data on AiResearch candidates was available within the AiResearch facility. However, it was necessary to solicit information from other small gas turbine manufacturers. Accordingly, a letter of inquiry was sent to Solar Division, International Harvester; Detroit Diesel, Allison; and Williams Research. These manufacturers all had equipment in the approximate size required to satisfy GPU output power requirements. Four gas turbine models were considered as candidate power plants for the advanced GPU: the AiResearch Model GTCP36-50D, a variation of the APU used on the A-10 aircraft; the AiResearch Model GTCP36-55C, the APU used on the Hughes AAH;

TABLE 4. SUBSYSTEM REQUIREMENTS

Subsystem	Requirement	HP	Conversion Efficiency	Engine HP Requirements
Electrical - 120/208 V, 400Hz 115 VAC, 60 Hz	20 kva 21 kva 1 kva	28.16	$\frac{1}{0.90}$	31.29
Hydraulic	3000 psi - 15 gpm	26.25	$\frac{1}{0.90}$	29.44
Pneumatic	34 lb/min 32.5 psig	40.0	$\frac{1}{0.80}$	50.00
		Total		110.73 HP
		Gearbox Efficiency	$\frac{1}{0.97}$	114.1 HP

the Solar Model T62T-40, the APU used on the UTTAS aircraft; and the Williams Research WR-27, the APU used on the Lockheed S3A. Characteristics of these gas turbines are shown on Table 5.

Since hardware descriptions available for gas turbines other than AiResearch were inadequate for design, the study was based on AiResearch engine models. It was felt that this approach would allow a valid comparison and selection to be made since the characteristics of units considered were so similar.

#### 2.4.1.2 Diesel

Four diesel engines were evaluated as applicable to the GPU, each of which was significantly larger than the engine used in the MSU-1. A larger engine was required for this application since the advanced GPU would be required to provide all three services simultaneously, whereas the MSU-1 was required to provide only one or two services at reduced output power levels. The diesel engine data was derived from QPL 11276. Diesel cost information was obtained by USAAMRDL from Mobility Equipment Research and Development Command (MERADCOM). The diesel engine models evaluated included the Detroit Diesel Models 4V-53 and 6V-53; the Allis Chalmers A-C2300; and the Cummins V-470. Evaluation of the Cummins engine was eventually stopped when it was found that this was a "throw-away" engine. Long service life is a requirement for the GPU; as a result, this kind of an engine did not appear appropriate for this study.

#### 2.4.2 Hydraulic System

Although a large number of components comprised the GPU hydraulic system, only the hydraulic pump and reservoir system were considered for trade off. The contract SOW required that the hydraulic system be designed to basic requirements of MIL-H-5440 and that the reservoir conform to MIL-R-8931. These two military specifications provided severe design restrictions on the hydraulic system, and necessarily limited the kinds of hardware that could be used.

##### 2.4.2.1 Hydraulic Pump

The basic SOW requirement to consider aircraft-qualified components wherever possible was followed in the hydraulic pump selection. However, it was felt that the aircraft hydraulic pumps available to perform the required function in the GPU system were not of adequate reliability to completely

TABLE 5. POWER PLANT CHARACTERISTICS

Description	Weight (lb)	Volume (in. 3)	Cost (3)	Reliability (MTBF-Hours)	Maintenance Requirement
<b>Diesel</b>					
AC 3500	1780	71,280	1.0	5000 (1)	High (2)
6-53	1800	76,576			
4-53	1650	71,130			
Cummins V470	1800	76,576			
<b>Gas Turbine</b>					
Air GTCP36-50D	114	7041	4.39	6000 (1)	Low (2)
GTCP36-55C	107.5	8612			
Solar T62T-40	108 (4)	7177			
W.R. 27	124	6097			

- NOTES: (1) Reliability includes basic power section only without accessory equipment. Installed reliability (MTBF) is 501 hours for diesel engine and 1154 hours for gas turbine. Diesel reliability is based on use of diesel fuel which is likely not available in Aviation unit. Diesel reliability is degraded for operation on jet fuel.
- (2) Precise figures were not available, however diesel maintenance requirement is understood to be higher than gas turbine on the basis of preventive maintenance required and relative difficulty in performing any maintenance due to size and weight of parts for diesel engines in this power class. The diesel also requires more frequent service (oil change, injector service, belts, hoses, etc.).
- (3) Cost shown is relative cost. Actual cost data is vendor proprietary. Due to competitive market, engine costs are assumed to be equal from various manufacturers. Diesel costs include ancillary equipment required to provide equivalent package for direct comparison i.e., cooling system, ether start kit, etc.
- (4) T62 weight is estimated based on bare engine (90 lbs) plus installation and accessory components (starter, load control valve, and inlet plenum).

satisfy all contract requirements. For this reason, an array of commercial hydraulic pumps was also considered. Discussions with various equipment suppliers and hydraulic system design engineers indicated that the main cause for a lack of system reliability in any hydraulic system was a lack of cleanliness and pump speed and, therefore, deterioration due to wear. For this reason, it was determined that each pump considered would be run at less than full rated capacity and at less than the pump rated speed to enhance life and reliability. Evaluation of the commercial pumps considered immediately revealed a second problem, in that the drive speed required was considerably lower than that normally found in aircraft hydraulic pumps. Aircraft system pumps normally operate in the speed range of 4000 to 8000 rpm, whereas commercial pumps operate generally in the speed range of 1500 to 2000 rpm. Characteristics of the hydraulic pumps considered are shown in Table 11, Page 66.

#### 2.4.2.2 Reservoir System

Contract requirements specified that the hydraulic system reservoir be Type II, which required that hydraulic fluid be separated from ambient air by a membrane, diaphragm, or piston. Review of existing aircraft equipment indicated that both the AAH and UTTAS aircraft models use a pressurized reservoir system. The system selected for the GPU would, necessarily, be required to fit all variations in the aircraft systems.

#### 2.4.3 Electrical System

Electrical systems for the GPU would consist of 400 Hz ac, 60 Hz ac, and 28 vdc. The 400-Hz ac system was the prime power supply used to service the aircraft. The 60-Hz ac requirement was intended as a convenience to satisfy the need for maintenance lighting and small hand tools. The 28-vdc system would be used for GPU battery charging only, since there was no need for external 28-volt power to the applicable aircraft.

##### 2.4.3.1 400 Hz Electrical System

Electrical system rating and performance were established in the SOW. A 20-KVA system was required to meet AAH and UTTAS aircraft needs, and the power quality was to conform with requirements of MIL-STD-704A, Category B.

Based on these requirements, inquiries were sent to certain manufacturers to determine the types of electrical generating systems that should be considered for the GPU. The "system" was to consist of the generator, generator control unit (GCU), and current transformers (CTs). The GCU was to include the regulator, logic, and protective devices.

Prospective suppliers were requested to place primary emphasis on systems already on military aircraft, preferably Army. The work statement included in Appendix B was sent to the following vendors:

- o Bendix Corporation, Eatontown, N.J.
- o Westinghouse Electric, Lima, Ohio
- o General Electric Company, Erie, Pa.
- o Lear Siegler, Cleveland, Ohio
- o Lucas Aerospace, Yorkshire England

#### 2.4.3.2 Battery Charger System

A battery charger system would be required for the GPU regardless of the GPU power plant start system chosen. This was necessary due to the need for some minimal 28-vdc capability for instrumentation and control. A system independent of batteries could be conceived, but the additional cost and complexity of fitting a permanent magnet generator (PMG) and associated controls to the existing off-the-shelf power plant would far outweigh any system weight advantage.

Due to interrelationships with other GPU systems, selecting the battery/charging system was not simple and straightforward. If only AAH and UTTAS were considered, the primary selection factor would be the GPU start system, i.e., the battery size for electric versus hydraulic or pneumatic starting. If all aircraft analyzed in Section 3 were considered, with their requirement for 28-vdc electric supply, a large TR unit sized for external aircraft requirements would become the primary factor, with battery charging only a secondary function. A third consideration was the 60-Hz ac system size requirement since a possible selection might consider a large TR unit with additional capacity to convert part of the 28 vdc to 60 Hz ac. Another potential arrangement evaluated used a 28-vdc starter-generator. This scheme was dropped in preliminary screening because of higher cost, higher maintenance, and potential power plant gearbox modifications required to convert the high-speed starter pad to a lower speed compatible with existing starter-generators.

#### 2.4.3.3 60-Hz System

The amount, quality, and characteristics of 60-Hz power were undefined in the SOW. Therefore, two approaches were taken to establish a 60-Hz system. One approach was to determine what type of 60-Hz supplies were available as a part of Army aircraft equipment. The other was to analyze the Aviation Unit Maintenance (AVUM) tool list to ascertain what type of equipment was likely to be used on the 60-Hz supply. This analysis also explored equipment power needs, i.e., motor

starting current, harmonic content, voltage regulation and level, connector plug type, and frequency sensitivity.

Thirteen manufacturers of 60-Hz power supplies were contacted. In addition to determining the various power supply characteristics, relative advantages of each type were also established. Both rotary and static types were investigated. Units operating directly from 400-Hz input were evaluated against units operating from a dc input. Both low and high voltage (28 and 115V, respectively) dc levels were considered. During analysis of dc input types, possible trade-offs with battery charging requirements were also investigated.

The manufacturers contacted and significant characteristics of their respective units included the following:

<u>Manufacturer</u>	<u>Unit Characteristics</u>
o Advanced Conversion Devices Passaic, New Jersey	dc to 60 Hz primarily, but could build 400- to 60-Hz sine wave output
o Flitetronics Burbank, California	dc to 60 Hz, 250 va optimum size, but can parallel units for higher output
o Unitron Garland, Texas	400 to 60 Hz available, military qualified; 3.5-KVA unit designed for UTTAS
o TOPAZ Electronics San Diego, California	Can supply dc to 60 Hz or 400 60 Hz. Wide range of catalog models
o Deltec Corporation San Diego, California	dc to 60 Hz only
o Interelectronics Congers, New York	dc to 60 Hz; has supplied many units for airborne applications
o Nova Electronics Nutley, New Jersey	Can supply dc to 60 Hz and 400 to 60 Hz
o Willmore Electronics Durham, North Carolina	dc to 60 Hz only; telephone company usage; temperature limited; square wave output
o Delta Electronics	dc to 60 Hz or 400 to 60 Hz; prefer higher dc voltage for lighter weight

<u>Manufacturer</u>	<u>Unit Characteristics</u>
o Power Tech Chatsworth, California	dc to 60 Hz only; limited to 600 watts
o Abbott Transistor Los Angeles, California	dc to 60 Hz only; 320 va a largest size presently available
o Leland Electronic Vandalia, Ohio	Rotary MG set, 400 Hz in, 60 Hz out; qualified for military aircraft
o Computer Power Madison, New Jersey	dc to 60 Hz, sine wave output

Following initial contacts, problem statements were sent to manufacturers indicating interest in the program and having units considered suitable for the intended use. The problem statement is included as Appendix C.

Manufacturers responses were analyzed and summarized as shown in Table 6. Several factors became evident as a result of the analysis. Evaluation parameters could not be confined to the established weight, volume, cost, reliability, maintainability, and mobility. Performance characteristics, efficiency, commonality, wave shape, temperature limits, overload capability, regulation, and protective circuitry all appeared to represent significant evaluation factors which should be considered in the trade-off described in Section 3. The 60-Hz systems considered are shown in Figure 4.

#### 2.4.4 Mobility

To enhance AiResearch capability in the mobility system, services of Vehicle Systems Development Corporation, experts in the field of vehicle mobility, were employed. Vehicle Systems provided mobility system descriptions that were used in the AiResearch technical proposal. A visit was made to Vehicle Systems shortly after receipt of the contract, during which a problem statement and cost estimate were obtained. The GCU mobility problem statement was well-defined in the contract SOW. Rough-terrain mobility, soft-soil mobility, and vehicle tow capability were all specified. Vehicle Systems agreed that to meet these contract requirements, towed vehicles suspended on high flotation tires and both solid and sprung axles, would be evaluated. Consideration would also be given to a skid-mounted device and a self-propelled device, based on one of the wheeled versions. Early in the GPU concept formulation task, additional requirements were established for the mobility system. These additional requirements included a

TABLE 6. 60 HZ POWER SUPPLY CHARACTERISTICS

Parameter	Manufacturer Number				
	No. 1	No. 2	No. 3	No. 4	No. 5
Units Required	1-3.5 KVA	1-2.0 KVA	8-250 KVA	1-2.0 KVA	1-1.5 KVA
Weight, lbs	95	80	129.5	185	70
Converter	95	80	8x15=120	165	70
Conditioner	--	--	9.5	20	--
Volume, cu. in.	1940	1940	3017	5000	1730
Converter	1940	1940	8x360=2920		1730
Conditioner	--	--	197		--
Converter Dimensions	10x9x21.6	10x9x21.6	7-1/2x12x4 ea	12-1/4x17x24	10.6x12x13.6
Relative Cost*	4	1	5	2	3
Conditioner	N.R.	N.R.	Yes	Yes	N.R.
Reliability				30,000 hrs	
Maintainability					Rotary
Related Factors			Multiple units		
Efficiency	80%	75%	0.68x0.80=55	70	53%
Wave Shape	5% dist	5% dist	7% dist	6% (sq wave)	
Input Conditioner	115 3φ,400	115 3φ,400	104A, 28 VDC	120V, 400 Hz 1	115 3φ,400
Noise					Factor
Temperature Limits	None	None	-10°F	-20°C	-10°C
Overload	20%-5 min	20%-5 min	50%-5 min	150%	50%-2 min
Regulation					
Voltage	+3.0 V	+3.0 V	+5.7-8.0V	+1%	+1.5V
Frequency	+0.6 Hz	+0.6 Hz	+1 Hz	+0.15%	Same as input
Usage	UTTAS	Com'1 A/C	Com'1 A/C	Vertol, WBBM-TV	Military A/C
Protection					S.C. Current Limit

\*Relative costs are rated from lowest, 1, to highest, 5. Conditioner cost, where required, is included.

LOAD ANALYSIS: TYPE LOADS: DETECTOR KIT HEAT GUN  
GRINDER TROUBLE LIGHT  
SOLDER IRON INSTRUMENTATION  
DRILLS TESTERS

POWER RANGE: 25 TO 2000 WATTS  
VOLTAGE: 120 V SINGLE PHASE 60 Hz  
POSSIBLE ALTERNATIVES: SQUARE WAVE OUTPUT, 110 VDC, -20°C OPERATION (-4°F)

CANDIDATE SYSTEMS

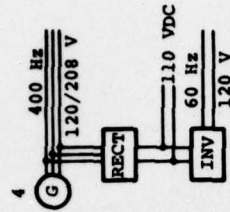
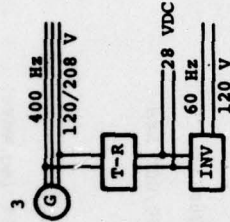
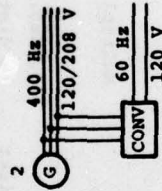
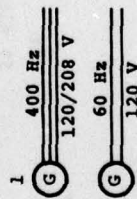

COMPONENTS NEEDED FOR 60 Hz	GENERATOR	CONVERTER STATIC OR ROTARY	TRANSFORMER-RECTIFIER INVERTER, STATIC	RECTIFIER ASSEMBLY STATIC INVERTER
FEATURES	INDEPENDENT CT 400 Hz LOWEST COST	FEWEST COMPONENTS UTILIZES 400 Hz SYSTEM PROTECTION	STANDARD COMPONENTS 28 VDC OUTPUT ISOLATED FROM 400 Hz	LIGHTEST WEIGHT 110 VDC OUTPUT ISOLATED FROM 400 Hz
DISADVANTAGES	COMPLICATES GEARBOX LOW SPEED DRIVE PAD, BELT DRIVE CONTROLS AND PROTECTION NEEDED	LIMITED AVAILABILITY 400 Hz WAVE SHAPE EFFECT	NON-OPTIMIZED COMPONENTS	NON-STANDARD COMPONENTS NEEDS FILTERING

Figure 4. 60 Hz system description.

capability for towing on improved roads at speeds up to 25 mph and the capability for rough-terrain towing by the M-151 1/4-ton truck.

All concepts were configured to meet the required ground mobility criteria: to be transportable as an internal load in either of the two UTTAS candidates, and to make maximum use of standard available components. For example, each of the concepts used the same type of tires, wheels, brakes, and steering system. The wheelbase length, trend, width, and height were comparable for all of the designs.

The advantage of being able to accommodate the GPU as an internal load in the UTTAS cabin related to the strategic deployment of the helicopter by such aircraft as the C-141 Starlifter and C-5A Galaxy (Figure 5).

While a full complement of UTTAS vehicles utilized the inter-theater transport aircraft internal volume, additional payload capacity existed in terms of weight-carrying ability that make accommodation of the GPU as an internal helicopter load of particular value in terms of maximum employment of available air lift capacity.

#### 2.4.4.1 Concept A GPU

Concept A was a conventional four-wheel layout with Ackermann-type steering on the leading axle, employed rigid axles, high-flotation tires, and rear wheel braking. Both the leading and rear axles were attached to the chassis by pillow blocks that were fastened to the integral chassis/fuel tank. Weight of the Concept A mobility element was 292 lb.

#### 2.4.4.2 Concept B GPU

The Concept B mobility element was identical to the Concept A layout with the addition of an air spring suspension system. Lightweight air springs with inflation valves were operated at 15 to 20 psi for the calculated gross GPU weight. Of standard design, the springs could be deflated to reduce overall GPU height.

Radius rods were used with the springs to limit lateral and longitudinal movement. The air suspension system resulted in a 60.8-lb weight increase over the Concept A GPU. Wheel base was also increased to accommodate the unit springs. Total weight for the Concept B mobility element was 353 lb.

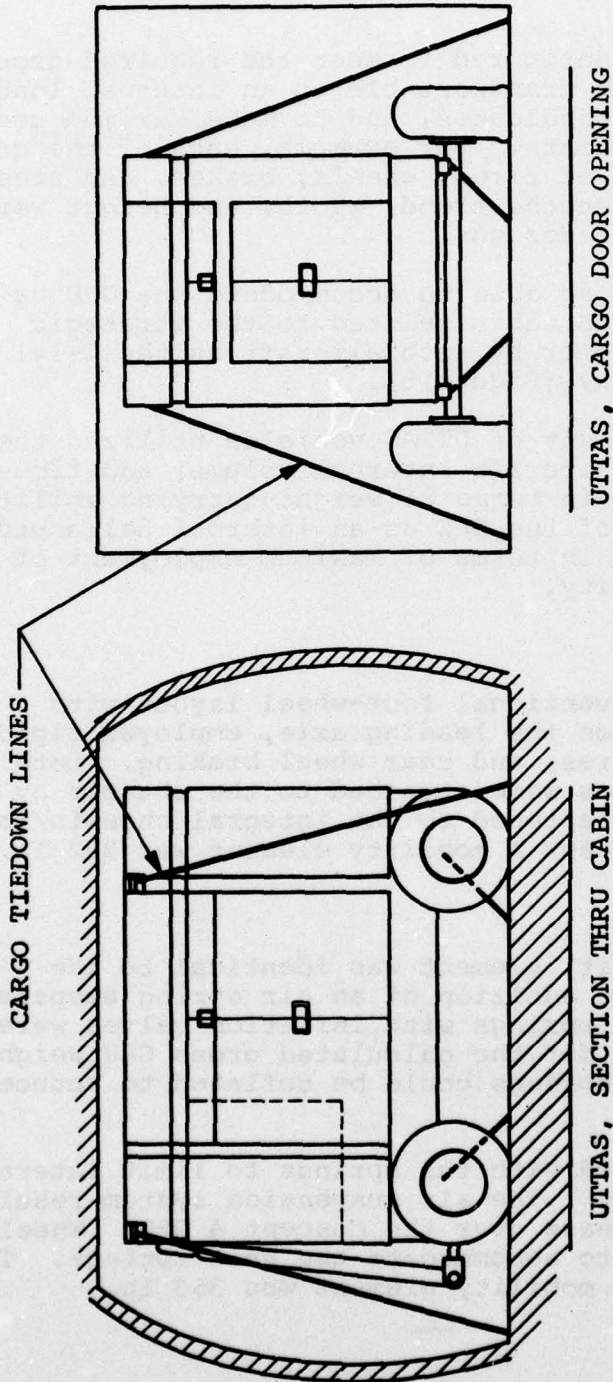

- NOTE: 1. AIR PRESSURE IN TIRES MAY BE REDUCED IF DESIRED.
2. GPU TRANSPORTED AS AN INTERNAL LOAD WHEN UTTAS IS DEPLOYED BY C-141 OR C-5A TO MAXIMIZE USE OF AVAILABLE VOLUME.

Figure 5. GPU as UTTAS internal cargo.

#### 2.4.4.3 Concept C GPU

Concept C was a self-propelled version of Concept A and employed an air motor to drive a single rear wheel. Power for the air motor was obtained by bleeding air from the GPU turbine. Speed reducer gearing and an over-center clutch arrangement permitted the operator to "walk" the GPU at up to 3 mph in either direction. A novel handlebar-type control unit was configured for mounting as a retractable extension of the conventional tow bar. This arrangement permitted tow bar employment in a conventional manner as well as serving as the medium for operator control in the self-propelled mode.

Weight of the advanced, self-propelled GPU drive, controls, and mobility element was estimated at 395 lb, an increase of 103 lb over Concept A.

#### 2.4.4.4 Concept D GPU

The skid-mounted GPU module was configured with standard-width forklift guides. The MIL STD, rough terrain forklift would be employed for local transport. A variation of this scheme would consider mounting the GPU skid base to the M101 trailer.

#### 2.4.5 Enclosure

The contract SOW required that lightweight, high-strength enclosure materials be considered in the enclosure system. These materials included aluminum, titanium, and composites. AiResearch had recently completed an evaluation of composite structures for an Army 30-KW gas-turbine-engine-driven generator set conducted under the auspices of MERADCOM. Results of this evaluation indicated that no significant benefit could be gained by the use of composite materials over a more conventional construction of bolted, riveted, or welded aluminum. Exotic materials, such as titanium or other high-strength alloys, did not lend themselves readily to fabrication of a piece of ground support equipment, since a minimum material thickness was generally required due to usage or manufacturing limitations. That minimum material thickness negated any advantage gained through the extreme high strength/weight ratio of the material under consideration.

##### 2.4.5.1 Composite Structures

Continued evaluation in the area of composites indicated that conclusions drawn from the initial 30-KW generator set evaluation might have been in error due to vendor selection. For this reason, a concerted effort was made to find vendors qualified to produce aerospace hardware. Ultimately, two

qualified vendors were found, although others are likely available. The two vendors represented different types of fabrication procedures. One used wet layup, molding the complete structure, controlling material thickness and resin content by tooling and raw material qualities. This system exploited the inherent design characteristics of composite structures. The second vendor fabricated structural shapes, i.e., sheet, tube, angle, channel, and beam. The structure developed by joining these standard components more nearly approximates conventional construction. Its advantage was developed through use of extremely lightweight fabricated composite materials. Assembly of this type of structure is probably more costly, due to requirements for joints and fastenings, similar to that of conventional riveted aluminum, for example. However, it avoided the necessity for expensive sophisticated molding tooling. A weight analysis of a typical structure, comparing composite and conventional aluminum construction, indicated an approximate 40-percent possible savings through use of composite structures.

#### 2.4.5.2 Conventional Construction

Conventional construction considered the use of 6061-T6 aluminum material in appropriate sizes and shapes to fulfill requirements of the particular area of application on the enclosure. Due to the requirement for structural integrity, the tank base would be made of 1/8-in. sheet, the enclosure walls 1/16-in. sheet, and the top 1/8-in. sheet. Angles, channels, and beams of the appropriate sizes and stiffness would be employed in the tank base both as structural members for engine mount and running gear attachment and as baffles to inhibit motion of the fuel.

#### 2.5 Start System

The contract SOW required that alternative starting means be evaluated for the GPU power plant. Since only limited power plant data was available from other manufacturers, the evaluation was based on AirResearch gas turbine starting systems. Results of this analysis still produced a valid comparison, since application of a specific starting system to any manufacturer's gas turbine or diesel engine represented approximately the same relative cost in dollars, weight and volume. No power plant offered a specific advantage to a particular starting system type. Start system characteristics are shown in Table 7.

Type System		Starter	Air Assist		
Electrical	Item	Electrical starter	Air pump (on starter)	Battery	
	P/N	519892 (A/R)	3884075 (A/R)	MS24498	
	Size (in. <sup>3</sup> )	4 dia x 7.25 (91)	3 dia x 2 (14)	11 x 10	
	Weight (lb)	8.0	1.0	80	
	Approx. cost (\$)	900	400	600	
	MTBF	10,000	25,000	Expend	
			P <sub>CD</sub> supercharge		
Pneumatic	Item	Vane system	Differential press. regulator	Accumul	
	P/N	PASS*	PASS*	PASS*	
	Size (in. <sup>3</sup> )	4 dia x 6 (75)		4.25 di	
	Weight (lb)	3.3	0.3	14.3 (e	
	Approx. cost (\$)	600	Incl. in manifold assembly	3800	
	MTBF	20,000	Incl. in manifold assembly	25,000	
	Misc. description	N = 0-12,000 rpm Op. press. = 200 psi Torque = 100 in.-lb	Regulated air from accumulator	Capacit start air a valve	
	*Pneumatic Actuated Start System				
Hydraulic	Item	Hydraulic start motor	Clutch driven	Elec. driven	Accumul
	P/N	4100139 (Aero-hydr)	3884075 + adapter	3884062	271099
	Size (in. <sup>3</sup> )	5.5 x 2.7 x 2.7 (40)	3 dia x 4 (28)	4.5 dia x 13 (208)	2 x 56
	Weight (lb)	3.5	3.0	8.5	2 x 25
		1800	700	78	3000-4
		10,000	25,000	40,000	50,000
		N = 0-14,000 rpm	Electro-	Alternate	Capacit
		Op. Press. = 3000- 3700 psig	magnetic clutch	air pump	2 at
	Disp. = 0.3 in. <sup>3</sup> /rev.				

TABLE 7. APU STARTING CHARACTERISTICS

	Power Source	Start Initiating Device	Recharge Backup	
ter)	Battery 34 amp-hr MS24498-1 11 x 10 x 11 (1210) 80 600 Expendable - life limited	Relay MS24184-D1 3.7 x 3.7 x 3.5 (48) 2.4 175 50,000 24-V switch actuated (common)  300 amp cont. 600 amp 1 min. 1800 amp inrush	Slave receptacle 7321299 (ord) 3 x 5 x 4 1.2 14 200,000 Batt. charge backup is common for all systems Manual backup-replace batteries	Ba N
ec. regulator	Accumulator with manifold PASS* 4.25 dia x 39 (ea) 2 reqd (964) 14.3 (ea) 2 at 28.6 3800 25,000 Capacity - 285 in. <sup>3</sup> ea includes start solenoid, regulator, air assist supply, check valve, etc.	Start valve    Bleed shutoff valve Manifold                    (25)  N/A                    50,000	Recharge compr. w/crank PASS* 12 x 18 x 12 (1152) 25.0 1500 25,000  APU bleed - driven Bleed = 4.5 lb/min 1.2 min to recharge 7.0 min - manual 0.75 lb/min char. rate	Ba M 1 1 3 E Ba
ec. driven 884062	Accumulator 2710996 (Parker-Hannefin)	Start solenoid valve Various	Hand pump Enerpac P-18	Ba M
5 dia x 13 (208)	2 x 565 =            (1130)	25	5 x 5 x 13 (325)	1
5	2 x 25.5 = 50.4	8	9.0	1
0,000	3000-4000 - Use 3500	150                    50	50	3
ternate	50,000	50,000	300,000	E
air pump	Capacity 300 in. <sup>3</sup> ea 2 at 600 in. <sup>3</sup>	24 V switch actuated (common) for all systems)	Hydraulic pump recharge	B

2

E 7. APU STARTING CHARACTERISTICS

Charge Backup	DC Supply	Power Transmission	Miscellaneous
receptacle 99 (ord) x 4	Battery (main power source)  N/A	DC cables with conn.  Est. length 17 ft (204) Est. weight 11 Est. cost 60	Batt. box, clamps, etc.  Est. volume addition 200 Est. volume addition 5 Est. cost 80
charge backup is for all systems 1 backup-replace series	Batt. charge power pack is part of frequency converter		
charge compr. w/crank 18 x 12 (1152)	Battery - 6 A H MA 500 H 12 x 5 x 5 (300) 15 300 Expendable - life limited	Pneumatic tube w/fittings  Est. length 9 ft (120) Est. weight 6 Est. cost 35  100,000	Batt. Box, valves brackets, etc.  Est. volume addition 25
bleed - driven 1 = 4.5 lb/min min to recharge min - manual lb/min char. rate	Batt. charge power pack is part of frequency converter		
pump pac P-18 5 x 13 (325)	Battery - 6 A H MA 500 H 12 x 5 x 5 (300) 15 300 Expendable - life limited	Hydraulic tube w/fittings  Est. length 20 ft (240) Est. length 10 Est. cost 140  50,000	Acc. air side fittings, valves, brackets, etc.  Est. volume addition 700** Est. weight 15** Est. cost 300**
000 hydraulic pump recharge	Batt. charge power pack is part of frequency converter		**Increase reservoir by 600 in. for non-self displacing accumulator

3

Miscellaneous	Summary		Remarks
t. box, clamps, etc.			
. volume addition	200	Size	1827 in. <sup>3</sup>
. volume addition	5	Weight	109
. cost	80	Cost	2229
		MTBF	5714
1. System required low temperature start aid.			
Options: Battery heater and thermal blanket - add 2 to 5 lbs and \$100 - \$250			
External heater - \$100 - \$500			
t. Box, valves brackets, etc.			
. volume addition	25	Size	2661
		Weight	82.7
		Cost	6365
		MTBF	6250
1. *PASS components are in development, costs are estimates only.			
2. This system offers best low temperature start capability.			
t. air side fittings, valves, brackets, etc.			
. volume addition	700**	Size	2778
. weight	15**	Weight	114
. cost	300**	Cost	6940
		MTBF	4919
		Alt.	2968
			119
			6318
1. System does not include approximately 15 lbs of additional hydraulic fluid and its cost.			
2. Air side of accumulator is not sealed. A standby high pressure pump is required.			
3. A self-displacing reservoir could reduce the volume by 600 in. <sup>3</sup> but cost is estimated to rise by \$200 to \$500.			
Increase reservoir by 600 in. <sup>3</sup> for non-self displacing accumulator			

### 2.5.1 Electric Starting System

The electric starting system consisted of a 28-vdc, high-torque, high-speed starter motor; a storage battery; and appropriate cables, relays, and attachments to properly install this starting system. The combination of storage battery and starting motor was selected so that a minimum of two successive starts could be made without restriction for cooling and/or delay between starts. The system was configured such that unrestricted operation at temperatures down to -25°F would be possible. At temperatures below -25°F, some auxiliary starting aid would be required, such as battery heating, external power, or a battery shorting device.

### 2.5.2 Hydraulic

Since the applicable aircraft APU start systems were all hydraulic, hydraulic starting of the GPU appeared to be a natural fallout. The hydraulic GPU starting system included the hydraulic start motor; two hydraulic start accumulators, since a two-shot capability without recharge was required; a hydraulic start initiator valve; and use of the hydraulic storage reservoir, systems, lines, and valves already in the GPU.

### 2.5.3 Pneumatic

AiResearch had developed a new and unique starting system for small gas turbines that utilized a small vane-type air motor. In function, a pneumatic start system was very similar to the hydraulic start system, having a start motor, pneumatic reservoir, starter valve, and recharge pump. The Pneumatic Actuated Start System (PASS) had been proposed for several applications and offered a significant weight advantage over either electric or hydraulic starting.

### 2.6 Design Layout

Although the original proposal for the GPU program did not anticipate a design layout until late in the concept selection phase, it became apparent as the component, subsystem, and system concept formulation data was accumulated that a layout showing the approximate size, weight, and general arrangement of the components in the system would be advantageous. A number of arbitrary selections were required, since none of the system components ultimately selected had been chosen at the time this layout was prepared.

Initial layout components consisted of the AiResearch Model GTCP36-50 gas turbine engine; Bendix 20-KVA, 12,000 rpm, 400-Hz alternator; Aero Hydraulics 15 gpm, 3000-psi, hydraulic pump, hydraulic start system consisting of the Aero Hydraulics starter, one 215 cu in. hydraulic accumulator, as used on the F-15 system; and the hydraulic system reservoir. Service conductors consisted of a 30-ft, 3-1/2-in. flexible air duct, two 30-ft hydraulic hoses of 3/4-in. and 1-in. diameter, and a 30-ft ac electrical cable. Wheels were shown in the original layout sketches; however, no running gear was defined. One of the purposes of the layout was to provide a basis for the subcontract with Vehicle Systems Development Corporation. Once hardware selections were made for the layout drawings, a preliminary weight estimate was prepared. Because only the major components had been considered in the preliminary design layout, a certain adjustment factor was considered in the weight estimate to accommodate those parts potentially forgotten. This preliminary weight estimate is shown in Table 8.

A second layout, Figures 6 and 7, was prepared subsequent to the visits to the airframe manufacturers and before initiating concept selection activities. The primary purpose of this second layout was to establish a baseline system to trade off the various system components. The layout incorporated more GPU detail hardware based on airframe manufacturer's inputs, a better understanding of GPU system requirements, and concept formulation activities. In addition, it provided increased consideration to installation detail, human factors, and mobility. The new layout contained all hardware and prime mover installation revisions to allow component, subsystem, and system trade-offs. These tradeoffs were to be made on the basis of differences from the standard shown in Figure 6.

The baseline unit shown had the following features:

- o AiResearch Model GTCP36-50 gas turbine engine
  - Single combustor
  - Two-pad gearbox
  - Hydraulic starting
  
- o Bendix Part No. 28B262 - 30/32 alternator  
(Used on prototype AAH)
  - 12,000 rpm
  - Air cooled
  - 400 Hz

TABLE 8. GPU ESTIMATED WEIGHT

Item	Weight (lb)
Exhaust box	45
Air cleaner	12
Fuel system	7-1/2
Generator	25
Hydraulic pump	10
Battery	34
Tank, enclosure, frame	200
Mobility equipment (wheels, springs, steering)	300
Electric service cable	35
Air hose	20
Hydraulic service hoses	35
Accumulator	9-1/2
Hydraulic filters	10
Engine	120
Control box	45
Contactator	7
CT	7
Battery charger	3-1/2
Wiring	7-1/2
Miscellaneous	20
<b>Total (Dry Weight)</b>	<b>953</b>

TABLE 8 (CONTD)

Item	Weight (lbs)
Fuel	300
Hydraulic fluid	12
Lube oil	5
<b>Total Fluids</b>	<b>317</b>
<b>Total Weight (wet)</b>	<b>1270</b>

Assumes: Accumulator 215 in<sup>3</sup>  
 Filters 140  
 Lines 100  
 Hydraulic fluid = 455 in.<sup>3</sup> @ 7 lb/gal = 12 lb  
 Hydraulic Start Motor and Initiator Valve = electric starter (included in engine)

Length 50 in.  
 Width 35 in.  
 Height 35 in. (to bottom of frame)

Frame is 4 x 2 channel 6061-T-6 0.15 wall

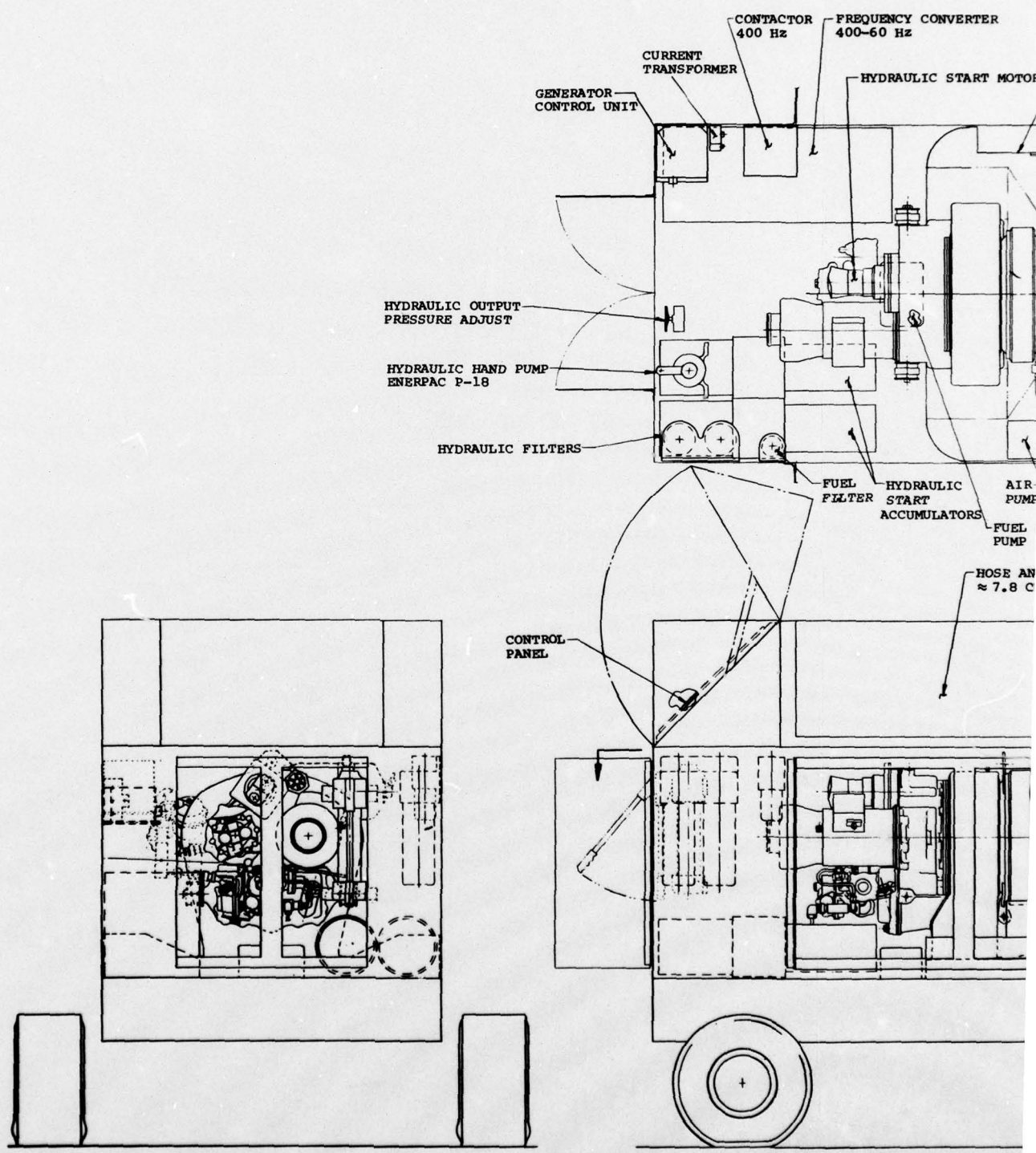
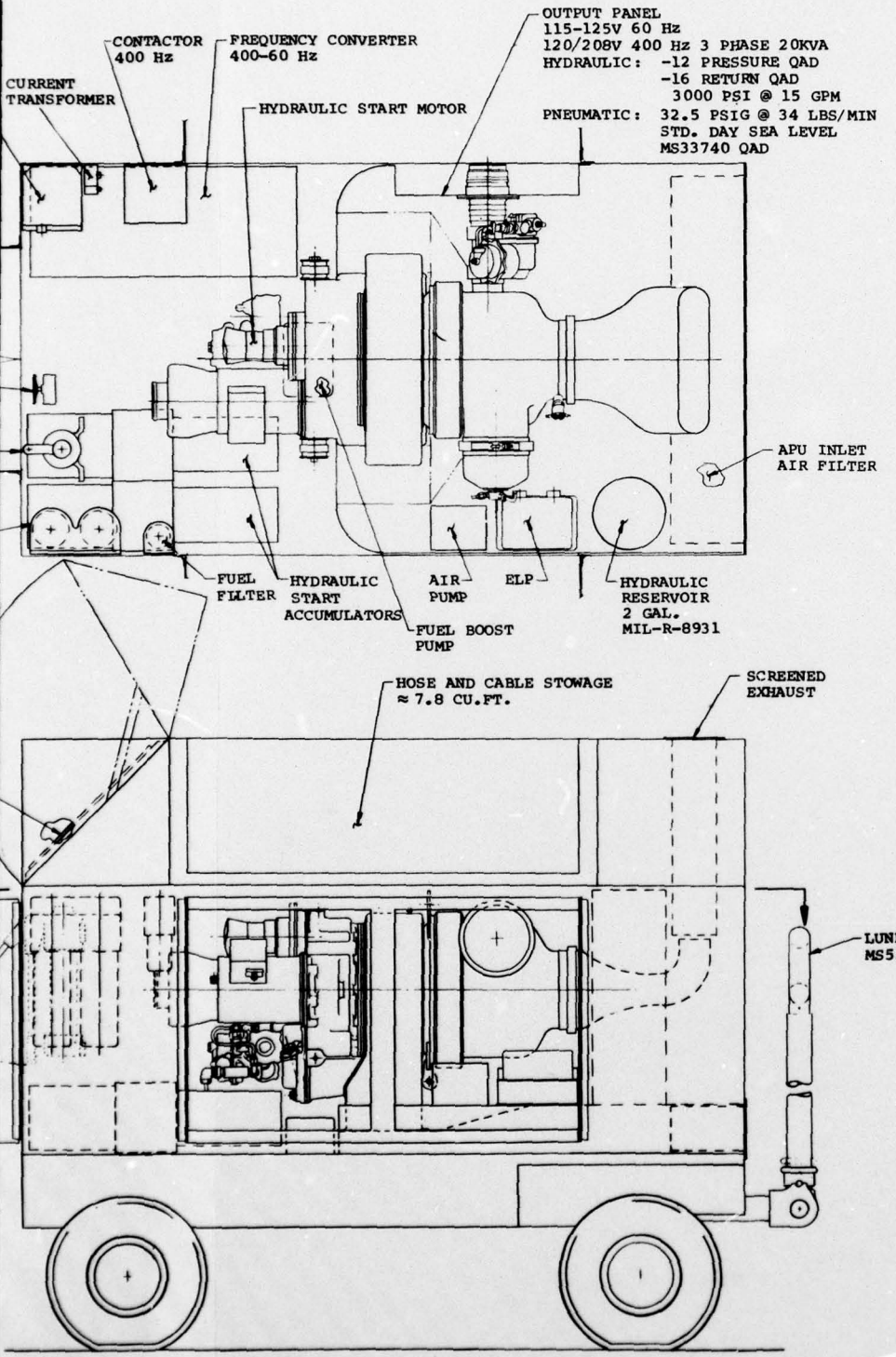

Figure 6. Baseline GPU layout.



2

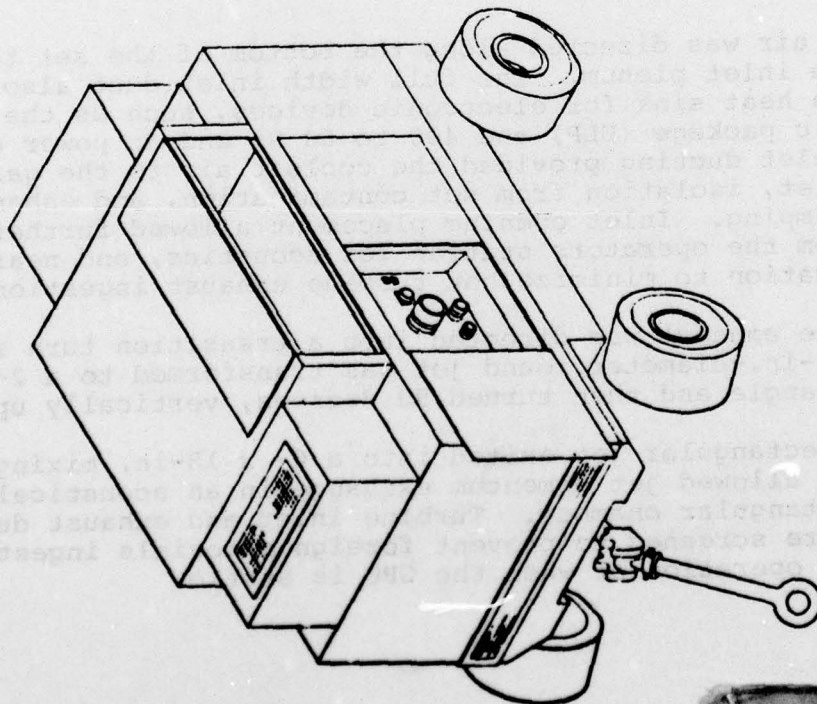
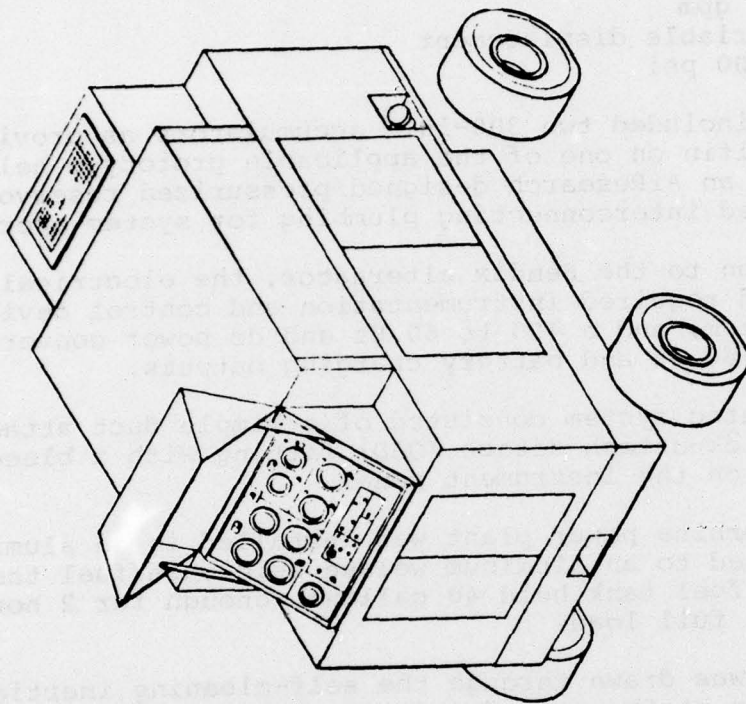

Figure 7. Baseline GPU.

PRECEDING PAGE BLANK-NOT FILLED

o AeroHydraulics Part No. 4110025 Hydraulic Pump

15 gpm  
Variable displacement  
3000 psi

The unit included two 300-in.<sup>3</sup> accumulators as provided by Parker-Hannifin on one of the applicable prototype helicopter models, an AiResearch designed pressurized reservoir, and the required interconnecting plumbing for system operation.

In addition to the Bendix alternator, the electrical system included required instrumentation and control devices for the ac system, and a 400 to 60 Hz and dc power converter to provide the 60 Hz and battery charging outputs.

The pneumatic system consisted of a simple duct attachment to the quick-attach-detach (QAD) fitting with a bleed load control switch on the instrument panel.

The gas turbine power plant was installed in an aluminum enclosure mounted to an aluminum welded skid base/fuel tank assembly. The fuel tank held 40 gallons, enough for 2 hours of operation at full load.

Inlet air was drawn through the self-cleaning inertial inlet air filter at the rear (opposite the control panel) bottom of the set. The self-cleaning function was driven by a small bleed air ejector.

Inlet air was directed along the bottom of the set to the gas turbine inlet plenum. The full width inlet duct also served as a heat sink for electronic devices, such as the engine logic package (ELP) and 400 to 60 Hz and dc power converter. Inlet ducting provided the coolest air to the gas turbine inlet, isolation from set contamination, and enhanced acoustic damping. Inlet opening placement allowed further removal from the operators station for acoustics, and near optimum location to minimize hot turbine exhaust ingestion.

Turbine exhaust was directed into a transition turn in which the 6-in.-diameter round jet was transformed to a 2- x 14-in. rectangle and then turned 90 degrees, vertically upward.

This rectangular jet exited into a 6- x 18-in. mixing section, which allowed jet momentum exchange in an acoustically treated rectangular chamber. Turbine inlet and exhaust duct openings were screened to prevent foreign materials ingestion both during operation or when the GPU is static.

Secondary airflow for the exhaust gas ejector was drawn through two oil coolers, one for engine oil and one for the hydraulic system. Cooler exhaust was then directed around the engine and installed components to maintain compartment air temperature and thus maintain component temperature at reasonable levels.

The service connector panel for hoses and cables was located on the left side of the unit away from the control panel. The connector panel was protected by a hinged cover when not in use.

All service conductors could be stowed in a closed locker at the set top, when not in use. Service conductors were 30 ft long and consisted of one 3-1/2-in.-diameter hose, one 4-conductor electrical cable, and two hydraulic hoses.

The unit was suspended on a solid axle mounted on wide base wheels with 13-in.-diameter high flotation tires, 6.5-in. wide. Steering was the Ackerman type. Steerable wheels were at the set aft end to keep the towbar from the control panel area.

A revised weight estimate was prepared from Figure 6. Excluding mobility equipment, system wet weight was 1112 pounds. The weight breakdown is shown in Table 9. Mobility equipment weight was estimated at 292 to 395 pounds depending on the final configuration selected. The unit shown in Figure 6 is a rigid axle system with 13-x 6.50-x 6-in. tires that weigh 292 lb. Therefore, total baseline system weight, as analyzed, is 1404 lb including fluids. The approximate center of gravity is shown in Figure 8.

## 2.7 Summary

After all component subsystems and systems to be used in the subsequent trade-offs and concept selection were defined, various combinations were arranged that could be used to satisfy total GPU system requirements. A summary of these combinations and arrangements is shown in the power generation system matrix, Table 10. This matrix considered only elements of the power generating system. It was not necessary to include the secondary systems of enclosure and mobility equipment since the choices were limited to only two selections in each area. A review of the power generation system matrix allowed a preliminary screening to be made of the various combinations possible for the overall systems. Preliminary screening eliminated those combinations that were obviously more complex, more costly, or more cumbersome than otherwise equivalent combinations. On this basis, the total number of trade-offs that might have been required was limited.

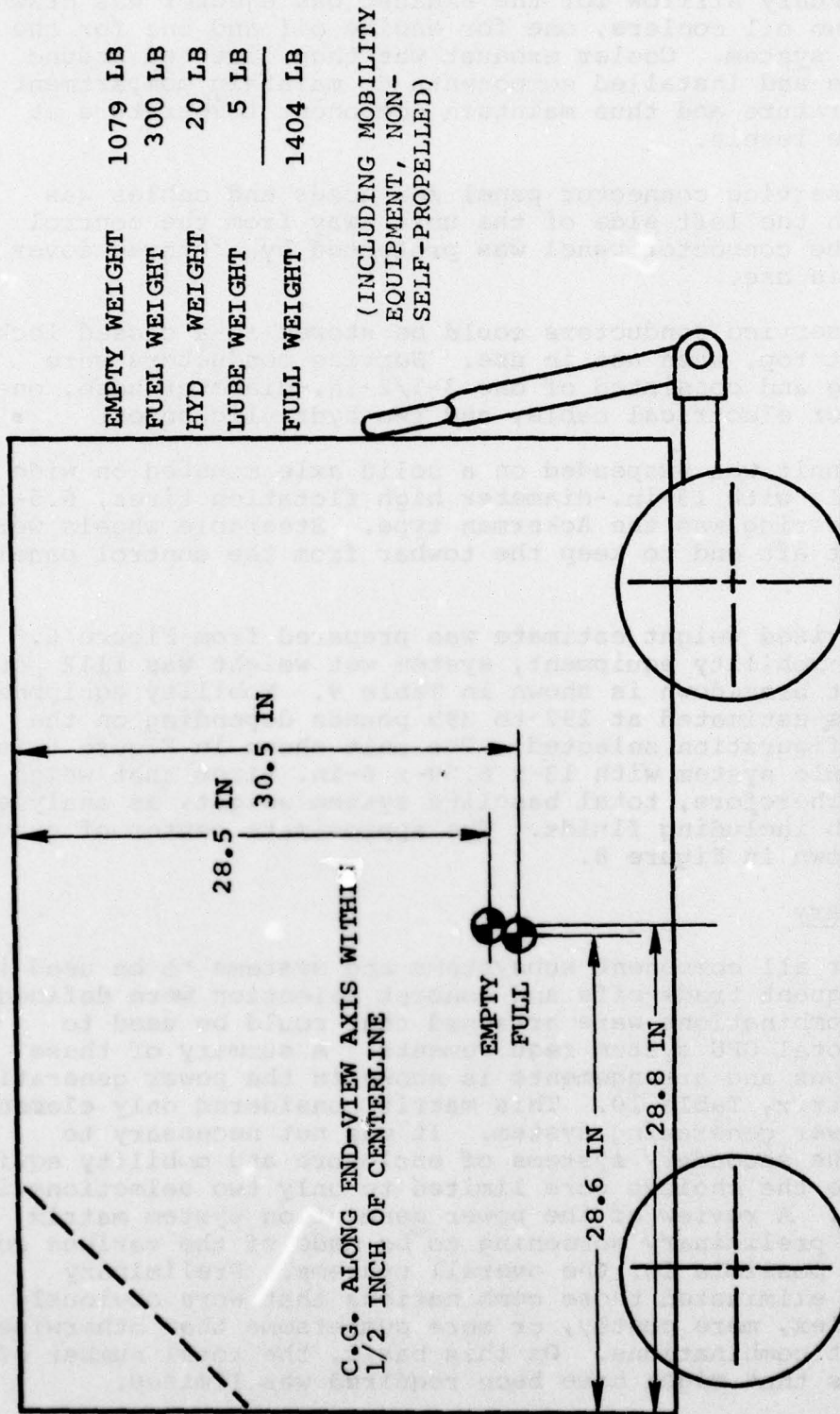

Figure 8. Center of gravity location.

TABLE 9. GPU WEIGHT BREAKDOWN

Item	Weight	
Tank, Enclosure, Frame	240	
Engine with LCV* and Control, Hydraulic Starter	117	
20 KVA, 400-Hz Generator	28	
Hydraulic Pump - 15 gpm, 3000 psi	7	
Engine Accessories		
Fuel Boost Pump	6	--
Air Pump (Start Fuel Vaporizer)	12	--
ELP (Engine Logic Package)	6	
		<u>24</u>
Service Conductors		
Pneumatic	20	
Hydraulic	35	
Electric Cables	35	
		<u>90</u>
Exhaust Box	45	
Air Cleaner	12	
Battery	6 amp-hr	15
Control Box w/Gages, Switches, Malf. Ind., etc.		30
Hydraulic System		
2 gal Reservoir	10	--
Filters	10	--
Hand Pump	10	--
Start Accumulator (2)	19	--
Misc., Start Valve, Hand Valve, Lines, Etc.	20	--
		<u>69</u>
Electrical System		
Contactor	7	
Current Transformer	1	
Battery Charger	5	
Frequency Converter	80	
Regulator	4	
Misc. Wiring, Connectors, etc.	8	
		<u>100</u>
Tailpipe		<u>5</u>
	Weight Empty	<u>787</u>
Fuel	300	
Hydraulic Fluid	20	
Lube Oil	<u>5</u>	
<u>Total, Including Fluids</u>	<u>1112</u>	

\*LCV = Load Control Valve

TABLE 10. POWER GENERATION SYSTEM MATRIX

System Description	Power Unit	Gearbox	Gearbox	Hydraulic Drive Motor	Hydraulic Pump	Air Drive Motor	Air Compressor	Electric Drive Motor	Generator
Engine Driven 3-Pad Gearbox	Diesel	NR	3-pad	NR	15 GPM	NR	34 lb/min 32.5 psi	NR	20 KVA 12,000 rpm
Direct Drive Alt-Piggy Back Hyd Comp	Diesel	NR	NR	NR	Low speed 15 GPM	NR	As above	NR	20 KVA 1,714 rpm
All Electric	Diesel	NR	NR	Electric	Low Speed 15 GPM	Elec.	As above	NR	100 KVA 1,714 rpm
All Hydraulic	Diesel	NR	NR	NR	Low Speed 67 GPM	Hyd.	As above	Hyd	20 KVA 8,000 rpm
All Pneumatic	Diesel	NR	NR	Air	Hi Speed 16 GPM	NR	70 lb/min 32.5 psi	Air	20 KVA 12,000 rpm
Direct Drive Alt-Belt Drive Hyd and Pneu	Diesel	NR	NR	NR	15 GPM 2K	NR	34 lb/min 32.5 psi	NR	20 KVA 1,714 rpm
Engine Driven* 3-Pad Gearbox	Gas turbine shaft	Single pad	3-pad	NR	15 GPM Hi speed 6K	NR	34 lb/min 32.5 psi	NR	20 KVA 12,000 rpm
Piggy Back Pump Drive	Bleed type	As above	2-pad	NR	As above	NR	NR	NR	20 KVA 12,000 rpm
	*Bleed type	As above	NR	NR	15 GPM 8K	NR	NR	NR	20 KVA 8,000 rpm
	*Bleed type	As above	NR	Electric	As above	NR	NR	NR	100 KVA 8,000 rpm
	*Bleed type	As above	NR	Air	As above	NR	NR	Air	20 KVA 12,000 rpm
	Bleed type	2-pad	NR	NR	15 GPM 6K	NR	NR	NR	20 KVA 12,000 rpm
	*Bleed type	2-pad	NR	NR	15 GPM 8K	NR	NR	NR	20 KVA 12,000 rpm
	*Bleed type	Single pad	NR	NR	67 GPM	NR	NR	Hyd	20 KVA 8,000 rpm

\*Dropped out in preliminary screening

Trade-off studies resulting from the power generation system matrix evaluation are shown in Figure 1.

### 3.0 CONCEPT SELECTION

The concept selection task was initiated once the arrays of components, subsystems, and systems were established in the concept formulation phase, and after the preliminary screening had been completed, eliminating obviously unacceptable approaches to solution of the problem. The concept selection task goals were to: develop a completely objective trade-off evaluation technique; trade off the various components, subsystems, and systems previously established; and select an optimum GPU system to satisfy the problem statement.

#### 3.1 Trade-Off Technique

The first step in the concept selection task was to devise an objective evaluation technique. As a part of the contract SOW, the Army had established a series of evaluation parameters which were, in descending order of importance: weight, volume, mobility, cost, reliability, and maintainability. The evaluation parameters were to be applied to component options previously determined to be able to meet the GPU physical and performance requirements. If a simple numerical rating of 1 through 6 was established and attached to these evaluation parameters, then weight would have six times the importance of maintainability, three times the importance of reliability, and only twice the importance of cost. It was felt that this provided a distorted representation of the true values of these various parameters. As a result, a system of weighting factors was sought to provide a true weighting of these features. It was decided that the total evaluation parameter range should span values from 1 to 2, thus limiting the importance of any one parameter to twice that of any other parameter; i.e., weight would be assigned a value of 2 and maintainability a value of 1, with the remainder falling in an intermediate position. This arrangement and concept was discussed with USAAMRDL for concurrence. Final weighting factors selected were: weight - 2.0; volume - 1.8; mobility - 1.7; cost - 1.5; reliability - 1.2; and maintainability - 1.0.

After the factors were established, the next step involved developing an evaluation technique using these weighted factors and evaluation parameters, and comparing different systems parts to allow the objective evaluation desired. A trade-off technique was developed in "The Secondary Power Systems Study for Advanced Rotary Wing Aircraft," conducted at AiResearch in 1972. In this study, one system was established as a baseline and all variation systems were compared and rated better or worse than the baseline on a percentage basis. Percentile comparisons were factored by application of weighting factors,

resulting in a total evaluation number. By comparing evaluation numbers, a component, subsystem, or system was selected on the basis of the lowest total number.

In testing this system for use on the GPU, it was found that the evaluation could be slanted, depending on the baseline selected. This deficiency was not obvious with compared systems having very close values. However, in evaluating components with very drastic differences in characteristics, such as the weight and volume in a gas turbine versus a diesel engine, the gas turbine or the diesel could be represented as a better selection depending upon which was chosen as the baseline. Once this deficiency was found, it became obvious that some other arrangement must be chosen to provide the objectivity desired in the selection process. It was ultimately determined that by selecting a baseline value rather than a baseline system, the necessary requirements for selection could be met. Application of this weighted value evaluation was used in each of the trade-offs discussed in subsequent paragraphs.

### 3.2 Detailed Trade-Off Analyses

Once all data required to describe the systems was compiled, trade-off analyses were started. Initiating these trade-offs was delayed due to difficulty in obtaining data from one airframe source, the GPU power plant vendors, and the 400-Hz power generation system vendors. To work around those problems, the best-defined components were evaluated first, with action on the remaining hardware delayed until more complete information could be provided.

#### 3.2.1 Hydraulic Pump

A study of hydraulic pumps comparing weight, cost, and reliability was undertaken (Table 11). Three basic hardware combinations were considered in this study: (1) aircraft hardware operated at design speed; (2) aircraft hardware operated at derated speed to increase life; and (3) commercial hardware operated at design speed. Consideration of these arrangements was based on the belief that typical aircraft hydraulic pump installations have low reliability at low weight and high cost, that commercial pumps have high reliability at high weight and low cost, and that derated aircraft pumps provide a compromise solution favoring weight, the most important evaluation criterion.

As data was accumulated, it appeared that assumptions on which this trade-off was based were not correct; i.e.; aircraft pumps applied at design conditions are not unreliable. Commercial airline data for Vickers pumps indicated pumps

TABLE 11. HYDRAULIC PUMP CHARACTERISTICS

Pump	Weight lbs	Displace- ment In <sup>3</sup> /Rev.	Rela- tive Cost*	Rated Speed - rpm	Rated Flow - GPM at 3000 psig	Volume In <sup>3</sup>	Application
Abex AP6VSC	11.6	0.97	5	3000	15	91.5	Chinook
Delavan RV3200	57.0	3.9	2	1200	16.4	Large	Commercial
Dennison PIV07-0020-51-06	167.0	4.05	5	1200	19.6	Large	Commercial
Parker PAV-32	55.0	1.95	1	1800	14.0	282.7	Commercial
Vickers PV3-044	6.8	0.44	6	8000	15.0	79.5	YS-11
-075	8.9	0.75	3	7000	22.0	117.8	C-130, A-7D, YAH-56
-115	11.5	1.15	4	6000	29.0	190.8	
-205	19.8	2.05	6	5900	43.0	212.0	
-375	28.0	3.75	7	5550	85.0	384.8	

\*Relative costs are rated from lowest, 1, to highest, 7.

were operated "on condition" with demonstrated MTBFs in excess of 10,000 hours (Tables 12, 13, and 14). No better MTBF could be predicted for derated aircraft pumps. Commercial pumps, by virtue of a 2-1/2 times weight increase, were quickly eliminated, resulting in selection of an aircraft pump for the application.

Table 15 presents the pump trade-off evaluation and final pump selection.

### 3.2.2 Start System

The starting system trade-off analysis comparing electric, hydraulic, and pneumatic systems is described in Figures 9, 10, and 11. Summary data showing characteristics considered in this analysis is provided in Table 16.

Since hydraulic APU start systems are used on the AAH and UTTAS aircraft, it was expected that the hydraulic system would be best for the GPU. Therefore, the validity of the analysis was questioned when the electric system proved to have the better score. Further review showed that cost and weight of one of the two accumulators installed on the aircraft is not included in the aircraft APU start system because one accumulator is required for other aircraft systems. Cost and weight of both GPU accumulators are included in the GPU start system.

The pneumatic system evaluated was the AiResearch Pneumatic Actuated Start System (PASS). This system used a small, vane-type air motor driven by a mixed air bleed system. Mixed air bleed was derived from a high pressure jet (2000 psia) supplied by an air storage bottle combined with ambient air in an ejector to provide mixed air at 200 psig to drive the air motor. The system used an air amplifier pump to replenish the reservoir between start attempts. The PASS system was the lightest of the three systems evaluated.

The electric start system was selected because it had the best overall score as shown in Table 16. Cost was a primary driving factor in selecting the electric start system.

### 3.2.3 400 Hz Electrical System

Preliminary analysis of data received from the potential 400-Hz system vendors made it apparent that parameters used in the trade-offs would have to be enlarged beyond the established factors of weight, volume, cost, reliability, and maintainability. In an attempt to keep engine gearbox changes to a minimum, a list was sent to the vendors indicating

TABLE 12. BOEING 747 1976 HYDRAULIC PUMP U. R. SUMMARY

AIRLINE	AMERICAN	AIR CANADA	DELTA	JAPAN A/L	PAN AM	TWA	TOTAL	UR/1000 PH
AIRCRAFT HOURS	9,309	12,856	2,547	54,228	65,397	26,779	144,337	
PUMP HOURS	74,472	102,848	20,376	433,284	523,176	206,232	1,154,696	
NUMBER OF AIRCRAFT	10 (5 mo)	6 (8 mo)	3 (6 mo)	27 (8 mo)	35 (6 mo)	10 (8 mo)		
REASONS FOR JUSTIFIED PREMATURE REMOVALS								
1. Pressure Fluctuation	1	0	1	0	1		3	0.003
2. External Leakage	9	0	6	21	6		42	0.036
3. Shaft Seal Leakage	1	1	1	9	10		22	0.019
4. E.D.V. Solenoid	0	2	0	0	2		4	0.003
5. Low or High Pressure	4	1	2	7	11		25	0.022
6. Piston Shoe	0	0	0	3	0		3	0.003
7. Miscellaneous	0	1	0	5	2		8	0.007
TOTAL JUSTIFIED	15	5	10	45	32		107	0.093
U.R./1000 PH	0.20	0.05	0.49	0.10	0.06		0.09	
UNJUSTIFIED PREMATURE REMOVALS								
1. Lost Fluid	0	0	0	1	2		3	0.003
2. Precautionary	2	2	0	40	8		52	0.045
3. All Others	11	7	5	11	11		45	0.039
TOTAL UNJUSTIFIED	13	9	5	52	21		100	0.087
U.R./1000 PH	0.17	0.09	0.25	0.12	0.04		0.09	
TOTAL ALL REASONS	28	14	15	97	53	48	255	
U.R./1000 PH	0.38	0.14	0.74	0.22	0.10	0.23	0.19	

MTEF = 10,791 MTEUR = 5,337

TABLE 13. L-1011 HYDRAULIC PUMP RELIABILITY SUMMARY FOR 1976

AIRLINE	AIR CANADA	ALL NIPPON	DELTA	TWA	TOTAL	UR/1000 PH
AIRCRAFT HOURS	16,642	20,435	31,892	45,014	68,969	
PUMP HOURS	99,852	122,610	191,352	270,084	413,814	
NUMBER OF AIRCRAFT	10 (8 mo.)	18 (7 mo.)	21 (7 mo.)	33 (8 mo.)	82	
REASONS FOR JUSTIFIED PREMATURE REMOVALS						
1. External Leakage	5	6	13		24	0.058
2. Shaft Seal Leakage	4	10	4		18	0.043
3. Low or High Pressure	0	6	3		9	0.022
4. E.D.V. Solenoid	1	0	1		2	0.005
5. Piston Shoe Wear	0	0	0		0	0.000
6. All Others	0	5	1		6	0.014
TOTAL JUSTIFIED	10	27	22		59	0.142
U.R./1000 PH	0.10	0.22	0.11		0.14	
UNJUSTIFIED PREMATURE REMOVALS						
1. Lost Fluid	2	1	3		6	0.016
2. Precautionary	1	4	4		9	0.019
3. All Others	12	4	8		24	0.051
TOTAL UNJUSTIFIED	15	9	15		39	0.086
U.R./1000 PH	0.15	0.07	0.08		0.09	
TOTAL ALL REASONS	25	36	37	70	168	
U.R./1000 PH	0.25	0.29	0.19	0.26	0.25	

MTBF = 8072 MTBUR = 4070

TABLE 14. BOEING 707/727/737 1976 HYDRAULIC PUMP U.R. SUMMARY

AIRLINE	AMERICAN	AIR CANADA	BRANIFF	DELTA	PAN AM	TWA	TOTAL	UR/1000 PH
AIRCRAFT HOURS	328,310	28,677	122,505	129,158	121,267	323,207	1,053,124	
PUMP HOURS	656,620	57,354	245,010	258,316	242,534	646,414	2,106,248	
NUMBER OF AIRCRAFT	203 (7 mo)	16 (8 mo)	72 (7 mo)	76 (6 mo)	76 (7 mo)	200 (8 mo)	643	
REASONS FOR JUSTIFIED PREMATURE REMOVALS								
1. Pressure Fluctuation	2	0	2	1	0	0	5	0.002
2. External Leakage	3	0	0	3	1	9	16	0.008
3. Shaft Seal Leakage	31	1	0	0	2	33	67	0.032
4. E.D.V. Solenoid	16	4	6	6	6	0	38	0.018
5. Low or High Pressure	19	5	13	5	8	37	87	0.041
6. Piston Shoe	18	0	10	3	2	48	81	0.038
7. All Others	21	1	5	20	5	13	65	0.031
TOTAL JUSTIFIED	110	11	36	38	24	140	359	0.170
U.R./1000 PH	0.17	0.19	0.15	0.15	0.10	0.22	0.17	
UNJUSTIFIED PREMATURE REMOVALS								
1. Lost Fluid	57	0	0	5	0	34	96	0.046
2. Precautionary	29	3	9	0	4	107	152	0.072
3. All Others	43	12	1	7	6	209	278	0.132
TOTAL UNJUSTIFIED	129	15	10	12	10	350	526	0.250
U.R./1000 PH	0.20	0.26	0.04	0.05	0.04	0.54	0.25	
TOTAL ALL REASONS	239	26	46	50	34	490	885	
U.R./1000 PH	0.36	0.45	0.19	0.19	0.14	0.76		

MTEF = 5866 MTEUR = 4004

TABLE 15. HYDRAULIC PUMP TRADE-OFF

Pump Model	Weighting factor		Weight (lb)	Volume (In. <sup>3</sup> )	Cost (3)	Reliability (rpm/Rated rpm)	Maint. Avail.	Total
	2.0	1.8						
	<u>Pump Speed (rpm)</u>							
PV3-044	8000	79.5 (1)	6.8 (1)	1.80	6.46	8000/8000	1.0	17.13
			2.00			3.54	3.33	
PV3-075	6000	117.8	8.9	2.67	3.23	6000/7500	0.7	13.84
			2.58			3.03	2.33	
AP6VSC	4000	91.5	11.6	2.07	4.62	4000/3000	0.3 (1)	15.82
			3.41			4.72	1.0	
PV3-205	2000	212.0	19.8	4.8	6.46	2000/5900 (1)	0.7	20.61
			5.82			1.20	2.33	
PAV-32	2000	283.7	55.0	6.41	1.50 (1)	2000/1800 (X2) (2)	1.0	29.39
			16.18			1.97	3.33	

(1) Baseline value

(2) X2 for commercial pump

(3) Actual costs are vendor proprietary - Weighted values were obtained by multiplying percentile comparison of individual pump cost with baseline cost by a weighting factor of 1.5.

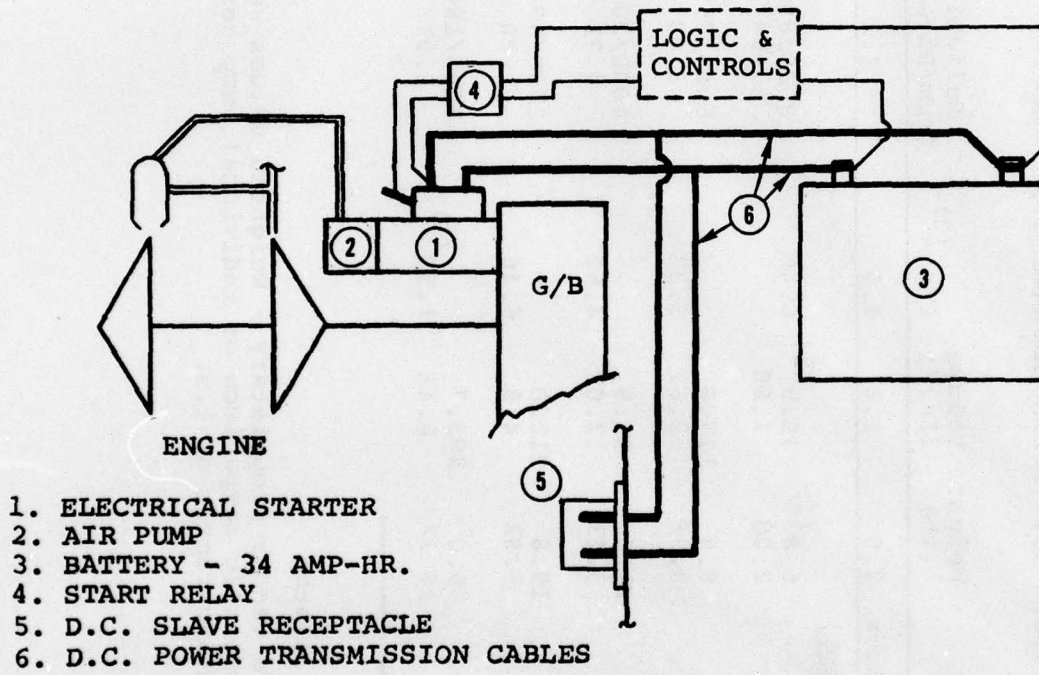
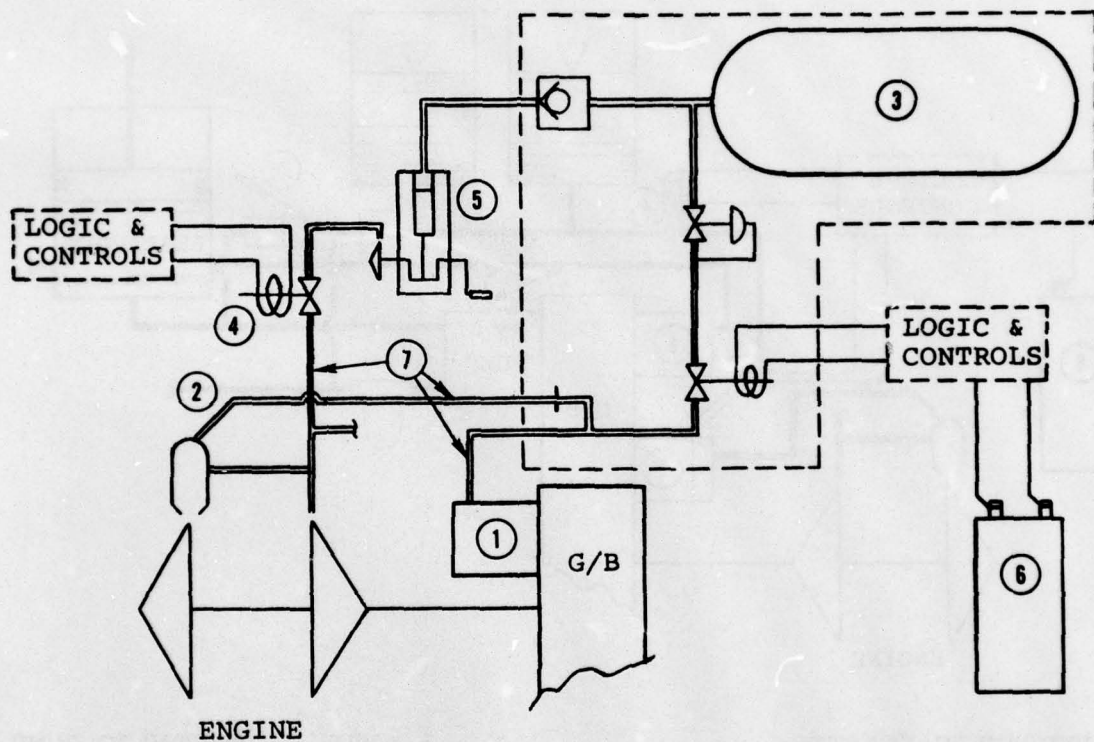
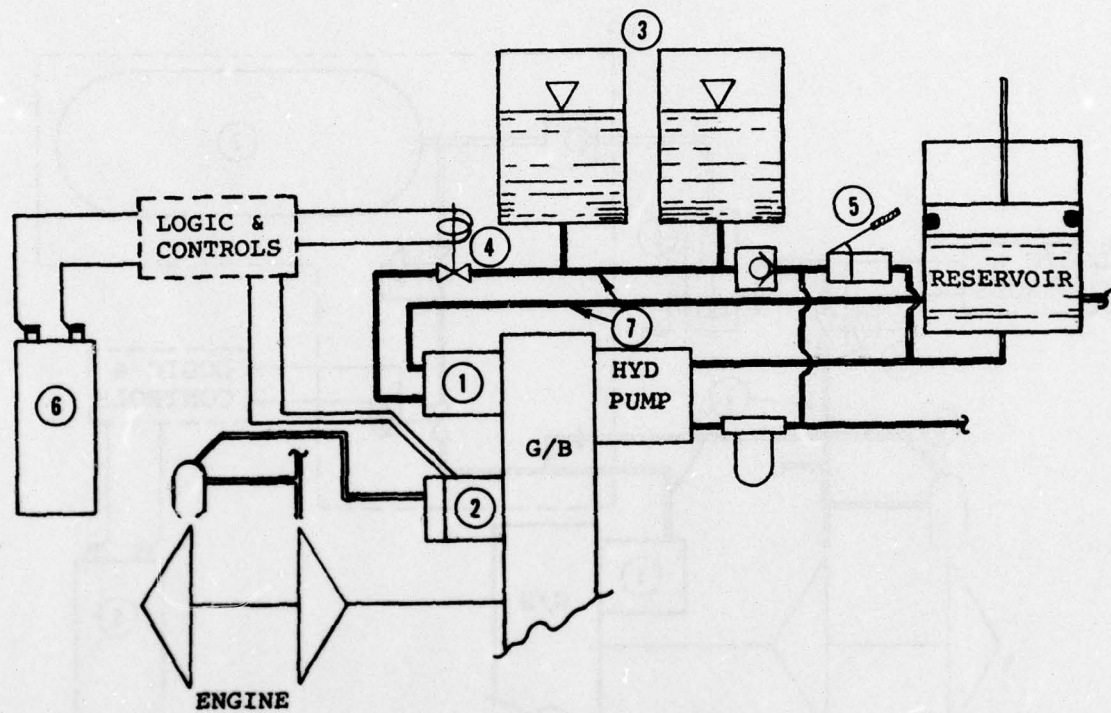

Figure 9. Electrical start system.



- |                         |                                       |
|-------------------------|---------------------------------------|
| 1. PNEUMATIC STARTER    | 5. RECHARGE COMPRESSOR W/MANUAL CRANK |
| 2. AIR ASSIST LINE      | 6. BATTERY - 6 AMP.-HR.               |
| 3. ACCUMULATOR/MANIFOLD | 7. PNEUMATIC TUBING                   |
| 4. BLEED S/O VALVE      |                                       |

Figure 10. Pneumatic start system.



- |  |                          |
|--|--------------------------|
| 1. HYDRAULIC STARTER                   | 5. MANUAL HYDRAULIC PUMP |
| 2. G/B DRIVEN, ELEC.-CLUTCHED AIR PUMP | 6. BATTERY - 6 AMP.-HR.  |
| 3. HYDRAULIC ACCUMULATOR               | 7. HYDRAULIC TUBING      |
| 4. START VALVE                         |                          |

Figure 11. Hydraulic start system.

TABLE 16. STARTING SYSTEM TRADE-OFF

System	Weight (2.0) lbs	Volume (1.8) in. 3	Cost (1.5) (2)	Reliability (1.2) MTBF - Hrs	Maintainability (1.0)	Total	Comments
<b>Electric</b>							
Starter	8.0	91		10,000/0.0001	0.7		System described was qualified for A10 Aircraft APU with 0°F electrolyte at -40°F. A-10 gearbox drives 10 gpm hyd. pump and 10 kva alternator. GPU start system should be limited to -25°F starts w/o assistance. External power required below -25°F; blankets and battery heater to maintain battery temperature.
Air Assist	1.0	14		25,000/0.00004	0.7		
Power Source	80.0	1210		Expendable	0.3		
Initiator	2.4	48		50,000/0.00002	0.5		
Recharge/Backup	1.2	60		200,000/0.000005	0.5		
DC Supply	--	--		--	--		
Power Transfer	11.0	204		100,000/0.00001	--		
Miscellaneous	5.0	200		--	--		
<b>TOTAL</b>	108.6/2.6	1827 <sup>(1)</sup> /1.8	1.5	0.000175 <sup>(1)</sup> /5714/1.2	2.7/1.0 <sup>(1)</sup>	8.1	
<b>Hydraulic</b>							
Starter	3.5	40		10,000/0.0001	0.1		Similar system was qualified for F-15 SFS at -40°F. System uses 2 300 in. accumulators. (3)
Air Assist	8.5	208		40,000/0.000025	1.0		
Power Source	50.4	1130		50,000 ea 0.00004	0.7		
Initiator	8.0	25		50,000/0.00002	0.7		
Recharge/Backup	9.0	325		300,000	1.0		
DC Supply	15.0	300		--	1.0		
Power Transfer	10.0	240		50,000/0.00002	--		
Miscellaneous	15.0	700		-- / 0.0000003	--		
<b>TOTAL</b>	1194/2.9	2968/2.9	4.6	0.0002053/48701/1.4	4.5/1.7	13.5	
<b>Pneumatic</b>							
Starter	3.3	75		20,000/0.00005	1.0		PASS characteristics are estimated only. System uses 2,285 in. accumulators. (3)
Air Assist	0.3	--		-- / 0.00004	1.0		
Power Source	28.6	964		25,000 ea 0.00004	1.0		
Initiator	2.5	25		50,000/0.00002	1.0		
Recharge/Backup	25.0	1152		25,000/0.00004	1.0		
DC Supply	15.0	300		--	1.0		
Power Transfer	6.0	120		100,000/0.000001	--		
Miscellaneous	2.0	25		-- / 0.000191	--		
<b>TOTAL</b>	82.7 <sup>(1)</sup> /2.0	2661/2.6	4.3	0.000191/5235/1.3	6.0/2.2	12.4	

(1) Best Value - Baseline

(2) Actual costs are vendor proprietary. Weighted values were obtained by multiplying percentile comparison of individual system costs by weighting factor of 1.5.

(3) Hydraulic and PASS both use dual accumulators for 2-shot capability.

preferences for speed, mounting-flange diameter, pad configuration, direction of rotation, overhung moment shaft damping, shear section, and maximum body diameter. This resulted in a trade-off parameter identified as "gearbox impact." Other parameters included system efficiency, cooling requirements, commonality, protective functions, need for auxiliary devices, lubrication needs, and amount of logic provided with the GCU. Trade-off results are summarized in Table 17.

The system selected was a Bendix model 28B262, three variations of which were available. One model was used on a UTTAS application, and the other two on the Hughes and Bell AAH aircraft. The Hughes version (-30) was chosen because it provided a large production base, was common to one of the selected aircraft, and its direction of rotation was compatible with the GPU power plant ultimately selected.

Subsequent to AAH contract award, the aircraft load profile grew until the 20-KVA alternator selected for the aircraft, and therefore the GPU, would no longer meet the 33-percent growth requirement. This required a size increase in the AAH generator to 30 KVA (or possibly even 45 KVA). As a result, the UTTAS version of the generator (-27) was selected. Because the UTTAS generator rotation direction was opposite to that of the AAH generator, it became necessary to determine whether the generator rotation should be changed to be compatible with the gearbox pad rotation or vice versa. The latter approach was selected since the gearbox was already designed to accommodate either direction of rotation with the simple addition (or removal) of an idler gear. The decision preserved use of identical (with the aircraft) part numbers for the generator, GCU, and current transformer. The actual rating of the selected generator is 20/30 KVA, which will permit up to 30-KVA output at sea level, with a normal overload capacity (150 percent for 5 minutes and 200 percent for 5 seconds).

The type of circuit protection used was not specified in the AiResearch work statement. Vendors were requested to stipulate the same type of protection, set points, time delays, and interlocks used on the aircraft. This ensured use of a system common to the aircraft and the same protection level to which the aircraft equipment was designed. In analyzing the level of protection, all functions were retained and used except for feeder fault. Feeder fault protection is normally included in aircraft generating systems since the generator could be located a considerable distance from the main contactor, resulting in relatively long runs of unprotected high voltage transmission lines. The GPU has very short lines from the alternator to the contactor (less than 5 feet), which are all

TABLE 17. 20 KVA ELECTRICAL GENERATING SYSTEM

Model	Weight (1) (lb)	Volume (in. <sup>3</sup> )	Cost (4)	Reliability (MTBF)	Maintainability (MMH/OH)	Related (2) Factors	Total
Weighting Factor	2.0	1.8	1.5	1.2	1.0		
Bendix 28B262	31.75 (3) 2.00	448 (3) 1.80	2.10	11,230 2.14	0.006 (3) 1.00	0.20	9.24
Westinghouse 976J255-5	50.5 3.18	769 3.09	2.95	16,800 1.43	0.006 1.00	1.10	12.75
Bendix 28B135	50.5 3.18	627 2.52	1.50	10,000 2.40	0.006 1.00	0.80	11.40
LSI 31161-001	53.0 3.34	815 3.27	3.30	10,000 2.40	0.006 1.00	0.40	13.71
LUCAS BA00201-C-1	57.75 3.64	685 2.75	7.82	20,000 (3) 1.20	0.0066 1.10	0.80	17.31

(1) Weight includes generator, GCU, and CTS

(2) Related Factors - Derating factors which consider efficiency, G/B impact (such as OH MOM, speed, etc.), cooling, usage and protective functions.

(3) Baseline Value

(4) Actual costs are vendor proprietary. Weighted values shown were obtained by multiplying percentile comparison of individual generator costs by weighting factor of 1.5.

visible with the access doors open, and are housed in a non-conductive enclosure. Therefore, feeder fault protection was felt to be superfluous in this application, and was deleted. The feeder fault function was retained in the GCU, but not used. This permitted elimination of one three-phase current transformer assembly.

The original concept included a capability to adjust operating voltage by a rheostat on the control panel. Voltage adjustment is normally not included in aircraft electrical systems, but is included in ground generator sets, to allow compensation for line losses for various power distribution systems. The line length and size provided on the GPU (30 ft of No. 4 conductor) are such that voltage drop is less than 1 volt and line length would not vary. Further, using the same GCU used on the AAH and UTTAS aircraft precluded availability of the voltage adjust feature for panel mounting. For these reasons, the voltage adjust feature was deleted.

As an element of concept selection, primarily for logistics purposes, parts lists of the various Army aircraft were evaluated for items that could be used on the GPU. Several components were identified, including contactors, relays, circuit breakers, instruments, terminal boards, switches, lights, and receptacles. Where practical, the GPU system specified use of these items. These items were selected directly without trade-off since it was determined that no significant cost or weight benefit would result.

#### 3.2.4 Battery Charge System

An electric start system was selected for the GPU power plant (3.2.2), which dictated the need for a 34-amp/hr nickel cadmium battery or its equivalent. The battery would provide starting current for the engine as well as for GPU control power needs.

The battery could be charged either by a dc generator or a static power supply. The generator would require an additional drive pad that was not available on the GPU. A dc starter-generator was also considered, which would perform the APU starting function as well as battery charging. The dc starter-generator would replace the starter motor. However, this would require a major change to the gearbox to accommodate the 6000 to 12,000 rpm starter-generator rotation speed. The starter pad was geared for a nominal 30,000 rpm. Starter-generator voltage regulation was similar to a transformer-rectifier (TR), which had caused battery reliability problems. Another negative factor was that the starter-generator was a brush type machine requiring periodic maintenance for the brushes.

Static power supplies considered were a conventional, unregulated TR type and a unit specifically designed for nickel cadmium battery charging. The TR units considered were identical to those used on Army aircraft to supply the aircraft dc bus. On aircraft, the batteries were floated across the bus to maintain a suitable charge. However, this method of charging was determined to be unsatisfactory. Aircraft maintenance practice specified that the batteries were to be removed after 100 hours of operation for recharging due to aircraft charging system deficiencies. A problem statement was prepared and sent to conventional TR manufacturers and battery-charger suppliers defining input power and output characteristics.

Battery charger and transformer-rectifier data was received and analyzed to determine candidate systems that would satisfy AAH and UTTAS needs, and changes required to meet other helicopter model dc needs. A "maintenance-free" system was recommended, which improved battery performance considerably over present methods of floating nickel-cadmium batteries on the 28-vdc bus. Four manufacturers, including Utah Research and Development Corp., General Electric Co., Gulton Industries, and Christie Electric Co., submitted data on these chargers. Three were suitable for portable ground cart use and could be procured to accept either a 400-Hz input or an input from the dc bus. System No. 1 in Figure 12 depicts the recommended scheme for an AAH and UTTAS GPU. The other systems are alternates which would satisfy the need for external dc output as described in Section 4.

### 3.2.5 60-Hz System

In reviewing the 60-Hz system characteristics (as well as other portions of the electrical system), it became apparent that performance characteristics such as efficiency, commonality, wave shape, temperature limits, overload capability, regulation, and protective circuitry all became significant in the trade-off. Weighting factors were assigned to each of these parameters and were added to the previously established factors. Candidate systems are described in Figure 4.

In reviewing the AVUM tool list, the following 60-Hz power devices were identified:

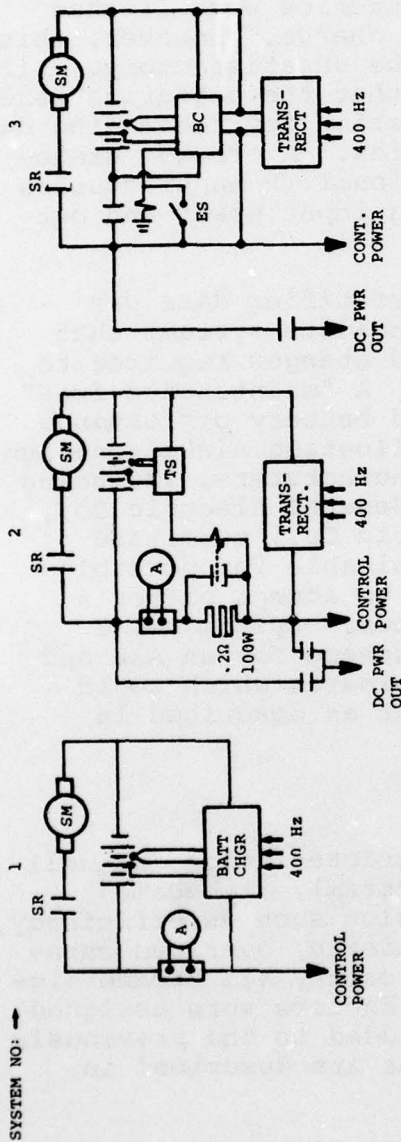

APPLICABLE TO: →

AAH AND UTTAS

ALL HELICOPTERS

WEIGHT	AAH AND UTTAS	ALL HELICOPTERS
AM + SHUNT CHARGER	4.9	7
TRANS-RECT	20	17
RELAYS/CONTACTORS/NOISE	-	7
<b>TOTAL</b>	<b>24.9 (TOT)</b>	<b>31 (TOT)</b>
<b>VOLUME</b>		
AM + SHUNT CHARGER	25	280
TRANS-RECT	373	410
RELAYS/CONTACTORS/NOISE	-	130
<b>TOTAL</b>	<b>398 (TOT)</b>	<b>820 (TOT)</b>
<b>COST</b>	<b>1.0</b>	<b>2.64</b>
<b>RELIABILITY</b>	<b>GOOD</b>	<b>EXCELLENT</b>
<b>MAINT. (SYS)</b>	<b>AVERAGE</b>	<b>MINIMAL</b>

Cost data is relative cost. Actual cost data is vendor proprietary.

Figure 12. Candidate battery charging systems.

<u>Federal Stock Number</u>	<u>Device</u>
6335-548-3991	Detector Kit
3415-517-7754	Grinder
4940-241-3075	Blow Gun
4940-785-1162	Heat Gun
6230-283-9671	Light Kit - 25W
6230-283-9246	Light Kit - 100W
3439-585-6057	Soldering Iron
4920-156-9946	Blade Tracker
4920-372-4593	EGT Temperature Tester

Of these, several would be usable on the 400-Hz system if a suitable receptacle were provided. In addition, several other tools such as electric drills would probably be used on the 60-Hz supply even though they did not appear on the tool list.

It was concluded that the heat gun imposed the governing load on the 60-Hz supply, requiring 1400 watts of power for the heater plus power for a 1/4-hp blower. This would require a 2- to 3-1/2-KVA converter to supply the heat gun load simultaneously with any other 60-Hz load. Following a coordination meeting, it was determined that cost, weight, and volume penalties imposed by such a converter were too great. Investigation revealed that the heat gun normally was used in the vicinity of a maintenance shop and would operate satisfactorily on rectified 400-Hz power. Eliminating the heat gun from 60-Hz load requirements reestablished the 60-Hz output rating at 750 to 1000 VA, which satisfied all other hand tool requirements.

It was also determined that a sine wave output was desirable (as opposed to square wave) since availability of a convenience outlet encouraged use of test instrumentation in addition to hand tools. Test instrumentation often incurs adverse effects when powered by a square wave supply.

Reviewing temperature limitations on converters/inverters, it was noted that all proposed models could withstand -65°F storage, but only one model could operate at -65°F. It was recommended that the operational temperature limit be raised to approximately 0°F with a condition imposed that the unit shall not be damaged when energized at -65°F. This requirement satisfied the majority of the instances where 60-Hz power was needed. At temperatures below 0°F, the converter/inverter would warm up through a combination of compartment heating from engine operation and energizing the unit. A warm-up time would be established and noted in the unit operating instructions.

Once it was decided to limit the 60-Hz power capability to 750 to 1000 VA, further vendor data was collected. These additional responses were also analyzed in an effort to find a converter suitable for GPU use. When 60-Hz power supply trade-offs were completed, a packaged 1-KVA model was selected as the best candidate. It was 20 percent lighter than any other contender and the least costly. The design is based on a laboratory model packaged into an assembly suitable for ground cart needs. Many components and circuits were identical to those used in the 3.5-KVA model selected for one of the UTTAS helicopter models. The final selection summary is shown in Table 18.

### 3.2.6 Enclosure

As noted in Para. 2.4.5, some of the lightweight, high-strength materials suggested as part of the SOW were eliminated in a preliminary screening process. This was due to physical factors, such as manufacturing or usage, requiring a minimum material thickness. Use of a minimum material thickness would generate a significantly over-designed piece of hardware negating the weight advantage of high-strength materials. For this reason, concept selection task activities were limited to evaluating and selecting either a simple fiberglass, or aluminum structure. During the Army's 30-KW generator set program, fiberglass was eventually dropped as an enclosure material since it offered no significant advantage over aluminum. Fiberglass did offer an increased risk in that no existing hardware of this material was available in using agency support inventory. The primary concern with use of any new material not presently in Army inventory was one of maintenance support, i.e., manpower, equipment, and facilities to effect repairs in case of damage to the equipment. This limitation is not present in the aviation unit, since a large number of individual components in the helicopters to be serviced would be fiberglass. In the search for advantages, disadvantages, and applications for fiberglass structures, a literature survey was conducted. Unfortunately, most available literature dealt with high-strength, lightweight applications, such as aircraft components, which truly utilized the excellent design capabilities of composite fiberglass structures. Materials generally included simple fiberglass, Kevlar, E-glass, S-glass, graphite, and boron fibers. One disadvantage of these materials was the extreme high cost. Simple fiberglass structures such as those eventually proposed for use in the GPU enclosure cost about \$2.25 a pound, compared to some of the exotic glass materials which ran as high as \$35 a pound.

In the MERDC 30-KW evaluation, a major disadvantage in the proposed fiberglass structure was the difficulty in controlling material thickness. Thickness variation amounted

TABLE 18. 60-HZ POWER TRADE-OFF

	Weight (lb)	Volume in <sup>3</sup>	Cost (3)	Related Factors (1)	Total
Weighting Factor	2.0	1.8	1.5	0.5	
Packaged	95	1940			10.1
3.5 KVA Unitron	4.5	2.7	2.4	0.5	
Packaged	63	1800			9.6
.75 KVA Unitron	3.0	2.5	1.6	2.5	
4 Module	54.5	1277(2)			10.7
.75 KVA Flitetronics	2.6	1.8	3.2	3.1	
2 Module	92.5	2677			12.4
.7 KVA Deltec	4.4	3.8	1.8	2.4	
Packaged, SPL.	42(2)	1900			7.5
1 KVA Unitron	2.0	2.7	1.5	1.3	
Packaged	110	2460			12.3
1 KVA Com'1 Topaz	5.2	3.5	1.8	1.8	
2 Module	115	1930			10.9
1 KVA Nova	5.5	2.7	1.6	1.1	
Rotary	70	1730			10.0
1.5 KVA Leland	3.3	2.4	3.0	2.2	

(1) Related Factors = Relative Efficiency, wave shape, overload capability, temperature limits, regulation and common usage.

Reliability and maintainability not used in trade-offs due to lack of creditable MTBF numbers and similarity in circuit design, construction and repair procedures for each manufacturers product.

(2) Baseline value

(3) Actual costs are vendor proprietary. Weighted values shown were obtained by multiplying percentile comparison of individual converter cost by weighting factor of 1.5.

to +0.030 in. A 0.125-in. wall thickness was desired; with the tolerance variation added to the desired thickness, a structural wall of up to 3/16 in. thick could result. The second problem involved resin content. A wet-layup structure had very high resin content. Resin was the largest weight constituent in the total enclosure system. Deficiencies associated with the 30-KW design were overcome through selection of a more knowledgeable vendor accustomed to aerospace-type structure design, development, and fabrication. The wall thickness problem was resolved by using a two-piece mold. This forced the wall thickness to fall within relatively narrow tolerance limits, such as those attainable by nesting two mold pieces together. By using preimpregnated glass material, the resin content problem could also be overcome. However, these techniques raised the cost of the fabricated component. The increased tooling and "pre-preg" material cost were offset by the savings in material allowed by better tolerance control on the parts. A second composite structure approach was evaluated, which considered the use of preformed materials such as sheet, tube, angle, channel, and rod, assembled in a fashion similar to that using metallic components in the same shapes. Joining techniques were different; adhesives were used instead of metallic fasteners. Components of this type are normally used in aircraft structures, and resin content and weight are precisely controlled. This technique could probably produce a lighter system than that formed by the two-piece mold arrangement. Tooling costs probably would be about the same, but assembly costs would be significantly higher due to the necessity of cutting, fitting, and bonding individual pieces.

Since the structure considered in the advanced GPU was very similar to that proposed for the MERADCOM 30-KW generator set, size, weight and cost estimates accumulated for that program were used in the GPU aluminum enclosure evaluation. The trade-off chart, Figure 13, shows the ultimate comparison between aluminum and the wet-layup, two-piece-mold fiberglass system. The fiberglass system allowed a weight and reliability advantage, and for this reason was selected for use in the GPU.

#### 3.2.6.1 Fiberglass Enclosure

Principal features of the GPU fiberglass structural body are illustrated in Figure 14. The structure consists of three primary subassemblies: the fuel tank, enclosure, and removable top (Figure 14A, B, and C, respectively). The fuel tank and enclosure will be permanently joined during fabrication of the body. The top, including hose and cable storage bin, are easily removable to facilitate power unit installation.

ALUMINUM

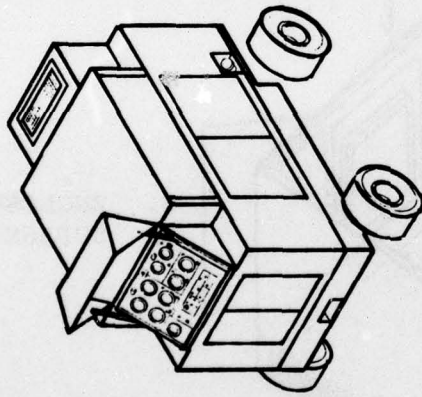
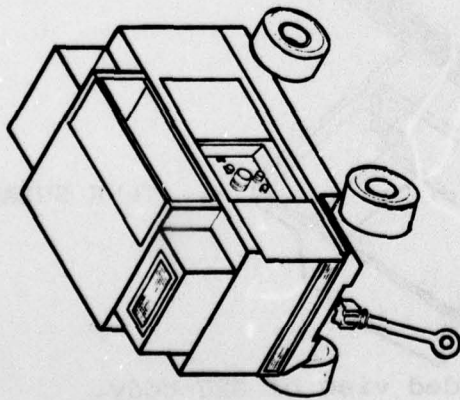

FIBERGLASS

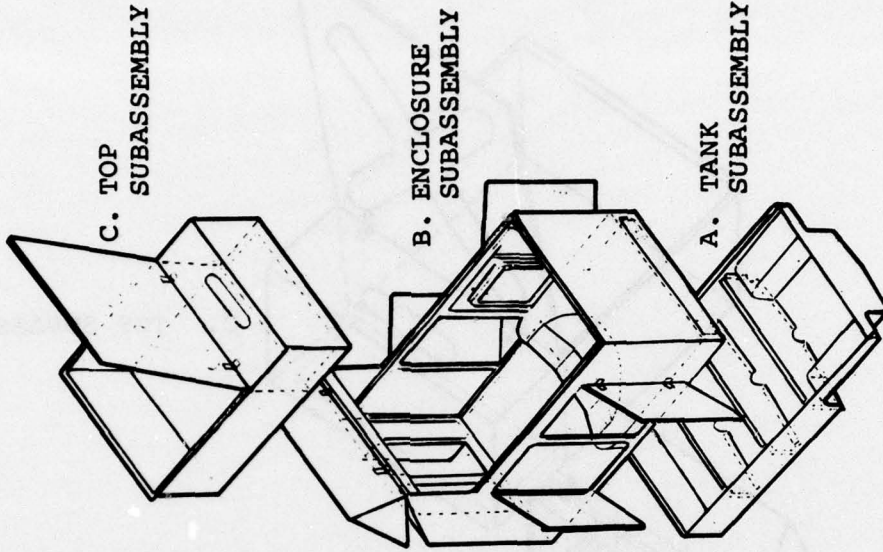

	ALUMINUM	FIBERGLASS
WEIGHT	240 LB	203 LB
COST	\$2000	\$2000
RELIABILITY	--	--
MAINTAINABILITY	--	--

Figure 13. Enclosure materials.

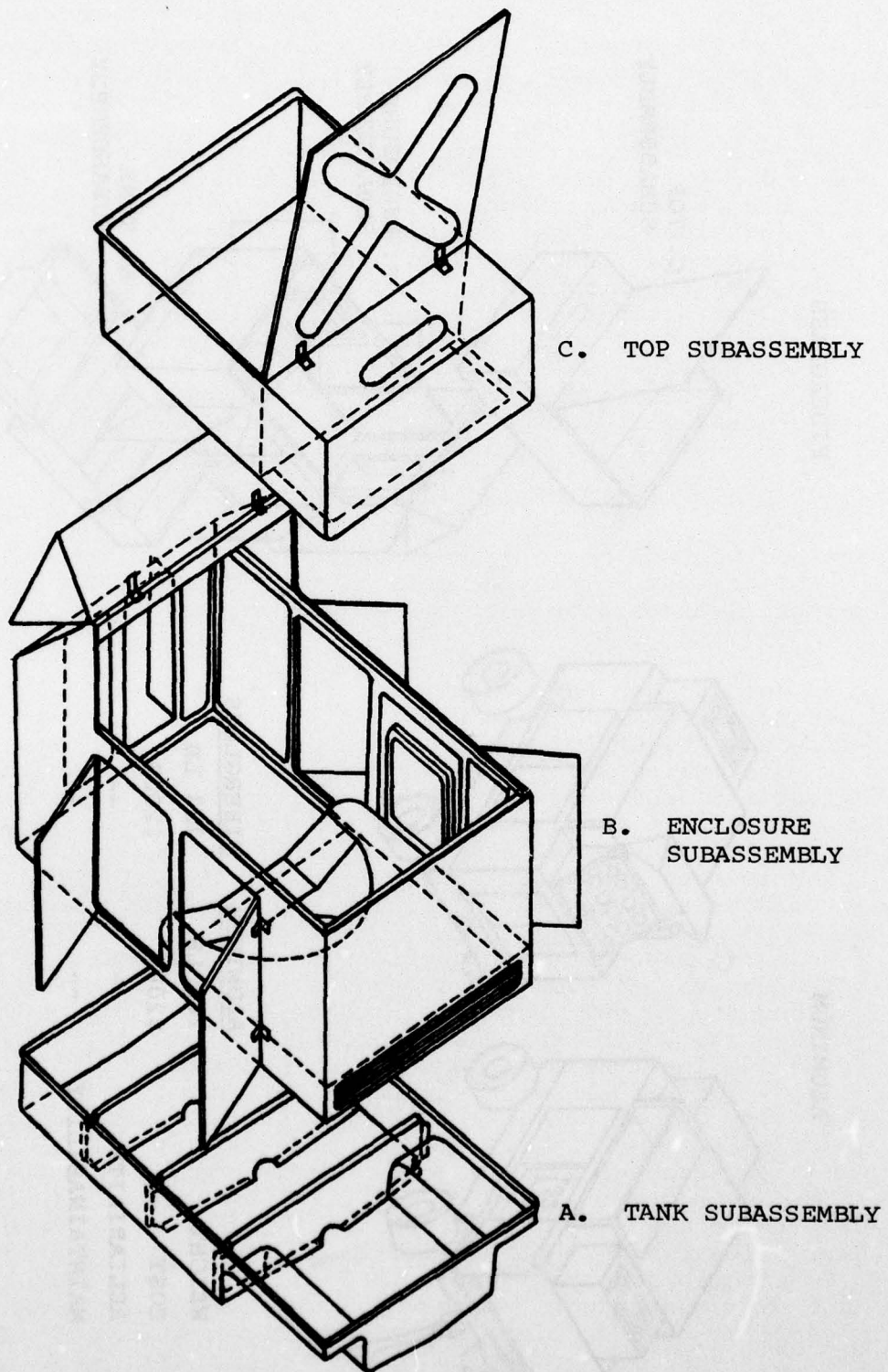

Figure 14. Exploded view of GPU body.

#### 3.2.6.1.1 Fuel Tank Subassembly

Fuel tank details are shown in Figure 15. The pan making up the bottom, sides, and ends of the fuel tank will be molded in one piece. Wheel cutout surface edges and corners would be rounded generously to improve moldability and reduce stress concentrations.

Separately molded bulkheads will be bonded in place at three locations as shown in Figure 15. The bulkheads serve as anti-slosh baffles as well as structural stiffeners, and have integrally molded flanges along the upper and lower edges and at the ends to provide bonding surfaces. The bottom center of the fuel tank is lower than the sides to facilitate low level fuel pick-up and drainage.

Suspension attachment locations are reinforced with extruded aluminum box sections. Nominal thickness of the tank pan molding is 3/16 in.

#### 3.2.6.1.2 Enclosure Subassembly

The central enclosure subassembly (Figure 16) is essentially an open topped box with the control panel, control panel cover, and air plenum added.

The enclosure bottom surface forms the top surface of the fuel tank when the fuel tank subassembly and enclosure subassembly are mated. The bottom surface of the enclosure also doubles as the bottom of the air plenum.

Edges of the door cutouts and the entire upper periphery of the enclosure are stiffened. Nominal thickness of enclosure panels is 1/8 in.

#### 3.2.6.1.3 Removable Top Subassembly

The removable top (Figure 17) is molded with the aft end, bottom, and sides of the hose and cable storage bin integral. A bulkhead forming the forward end of the storage bin is bonded in place after the initial molding is made. The top surface forward of the storage bin also is permanently bonded to the initial molding. Storage bin covers and quick disconnect fasteners complete the subassembly. The bottom of the subassembly forward of the storage bin is open except for stiffening around the periphery.

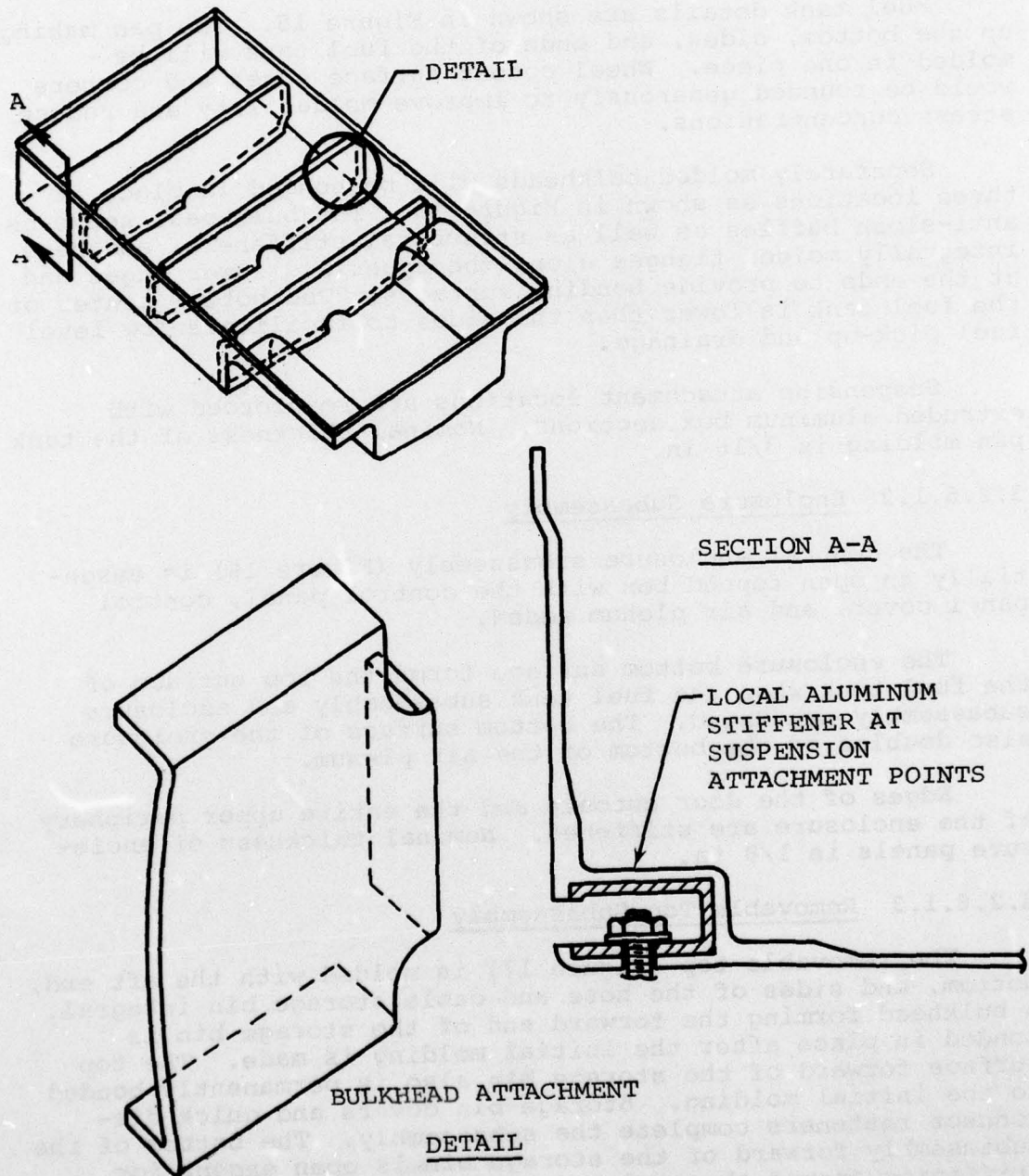
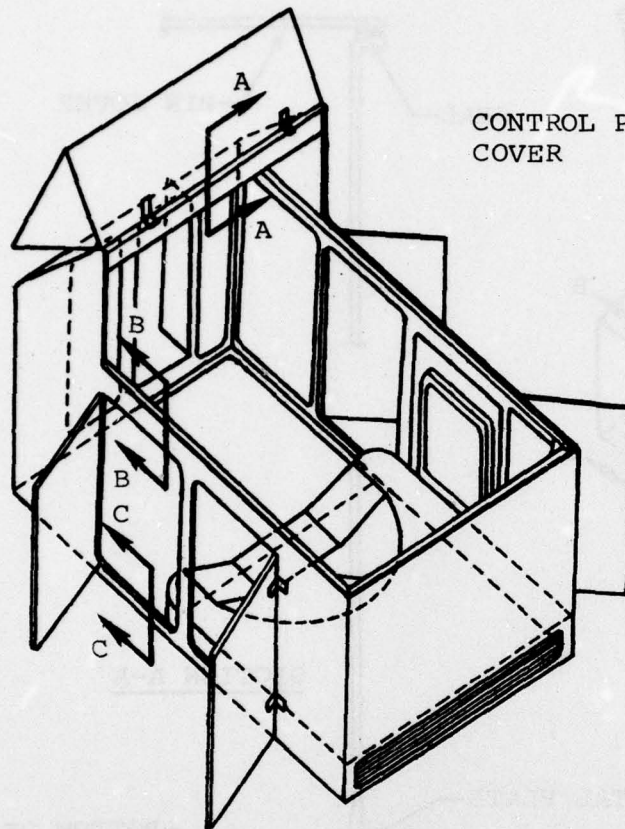
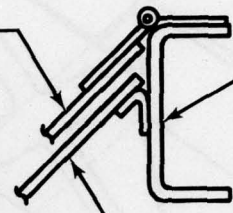

Figure 15. Fuel tank details.



CONTROL PANEL COVER



CHANNEL

CONTROL PANEL

SECTION A-A

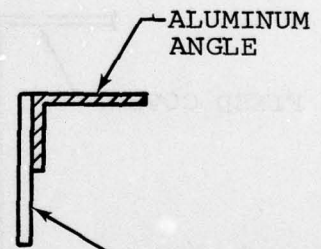

ALUMINUM ANGLE

LAMINATE

SECTION B-B

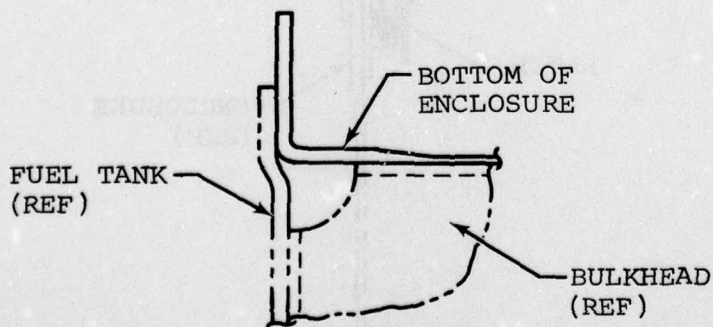

FUEL TANK (REF)

BOTTOM OF ENCLOSURE

BULKHEAD (REF)

SECTION C-C

Figure 16. Enclosure details.

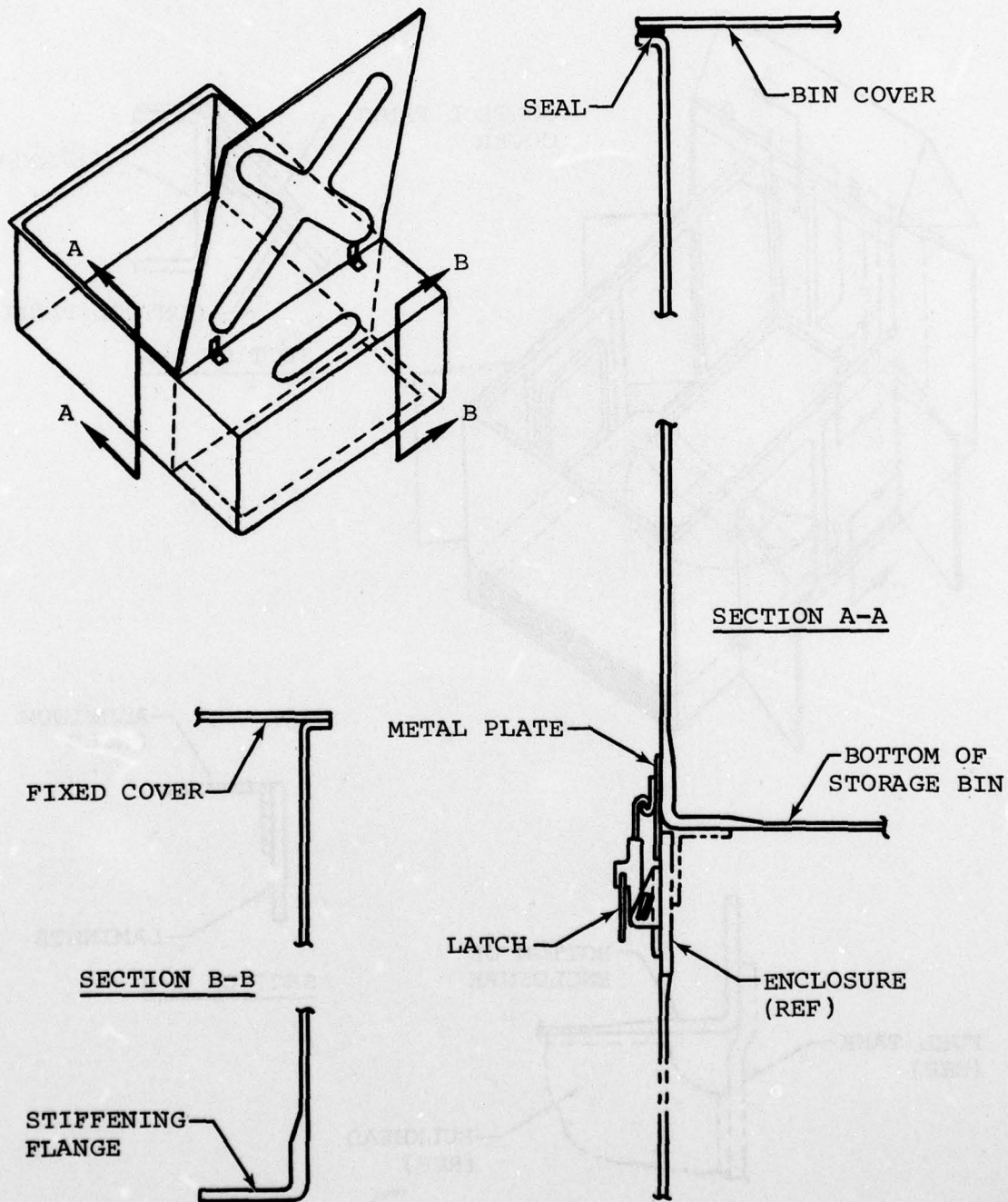

Figure 17. Removable top details.

#### 3.2.6.1.4 Materials

Primary structural elements are molded of glass reinforced epoxy material. Reinforcement is in the form of woven roving for strength and random mat for interlaminar toughness. Minimum tensile strength will be 25,000 psi and specific weight 0.065 pound per cubic in.

Aluminum angle stiffeners around the upper edge of the enclosure and box section reinforcements at the suspension attachment points will be 6061-T6 extrusions.

#### 3.2.6.1.5 Weights

Preliminary weight analysis results are listed below. Weights were based on nominal panel thicknesses of 1/8 in. except for the fuel tank subassembly for which 3/16 in. was assumed:

Fuel tank	51 lb
Tank baffles	9
Enclosure	54
Enclosure stiffeners and hardware	27
Plenum	15
Storage bin	<u>47</u>
Total	203 lb

#### 3.2.6.2 Aluminum Enclosure

The aluminum enclosure would be fabricated of standard sheet and structural forms of 6061-T-6 aluminum. The skid base and tank assembly would be of welded construction.

The tank would include internal structural members for engine mounting frame and running gear support. The location and shapes of these members could also allow them to function as baffles to prevent sloshing inside the tank. The enclosure would consist of four basic elements: control panel/module assembly; front enclosure half; rear enclosure half; and exhaust box. These elements would be of 1/16-in. sheet, using self-framing design members wherever possible. Elements would be attached together and to the skid base/tank assembly with 1/4-20 hex-head bolts and nuts. The control panel/module would be a bolt-in assembly so that the complete assembly or the panel alone could be removed for servicing control components. The front enclosure half would include two access doors to electrical and hydraulic system components, and would be removable, with the control panel module installed, without disassembly of the complete set. The rear enclosure half

would also contain two access doors to the gas turbine, controls, and hydraulic system elements. The rear enclosure half would have the same maintainability features as the front enclosure half. The exhaust box was merely a shroud to house the stainless steel exhaust muffler and curved transition pipe from the gas turbine. The service conductor stowage box would be a separate removable element at the extreme top of the enclosure. This box would have a wraparound door arrangement so that the complete stowage box could be exposed, allowing easy stowage of the service conductors. All access panels and layout of the components requiring service inside the enclosure would be designed for easy maintainability. Components requiring regular service would be placed near access openings. All piping and wiring inside the enclosure will be attached to the GPU power generation system, so elements of the enclosure could be removed without requiring disassembly of other enclosure subsystems.

Maintainability features would be applicable either to the all-aluminum or fiberglass enclosures.

### 3.2.7 Mobility

Mobility requirements specified for the advanced GPU were: gradeability on a 3-percent slope in soil with a Cone Index (CI) of 50, and gradeability on a 27-percent slope in soil with a CI of 125. The GPU also must be capable of a towed road speed of 25 mph. The 16 x 6.50-8 Terra-Tire was selected to meet these requirements. With an inflation pressure of 20 psi, the Terra-Tire could accommodate a single tire load of 350 pounds at speeds up to 30 mph. Assuming a gross vehicle weight (GVW) of 1400 lb (350 lb x 4 tires), reserve capacity at 25 mph would be provided and would readily satisfy the improved surface requirement. Mobility analysis of the towed version advanced GPU, with the Terra-Tires at 20 psi and employing the Waterways Experiment Station (WES) towed wheeled vehicle equation, indicated a single-pass Vehicle Cone Index ( $VCI_1$ ), in soil with a CI of 50, of 35 to 39, providing ample mobility reserve (15 to 11 points) in the lowest strength soil specified. Towing resistance could vary from a low of 196 lb to a high of 490 lb, well within the capability of the 1/4-ton truck which has a  $VCI_1$  of 19, some 31 points below the soil CI of 50 and providing ample mobility for negotiating the prescribed slopes. The self-propelled version of the advanced GPU would have a similar  $VCI_1$  range and overall mobility characteristics comparable to the towed vehicle. The drive could be easily disengaged to permit GPU towing at the prescribed road speed.

AD-A052 652

AIRESEARCH MFG CO OF ARIZONA PHOENIX  
ADVANCED TECHNOLOGY SERVICING EQUIPMENT FOR ARMY AIRCRAFT.(U)

F/G 1/5

UNCLASSIFIED

31-2491B

USAAMRDL-TR-77-33

DAAJ02-76-C-0042

NL

2 OF 2  
AD  
A052652



Nominal Unit Ground Pressure (NUGP) values for the three concepts described in Para. 2.4.4 were:

Concept A	(psi)	11.4
Concept B	(psi)	12.0
Concept C	(psi)	12.4

Values were based on the following: Concept A, gross vehicle weight (GVW) = 1281 lb; Concept B, GVW = 1342 lb; and Concept C, GVW = 1384 lb.

Running gear selections for the GPU were as follows:

	<u>United</u>	<u>Saginaw</u>
Front axle	OA1-2022	15285-A
Steering	6LOT325	6853-A
Drawbar	48-7016	6954-3
Rear axle	2522A (Mod.)	10963 (Mod.)
Suspension	1-1656 (Leaf Springs)	1460 (Leaf/Air)
Hub assembly front axle	7-625 (5/4.5 dia. B.C.)	6403-M
Hub assembly rear axle	9-625 (W/7 x 1.75 Drum)	6403-M
Brake assembly	3-8142(w/Park)	6437 (w/Park)
Brake rigging	7066R	31110
Wheels (4)	DICO 7521 (5/4.5 Dia B.C.)	Same
Tires (4)	Goodyear (16 x 6.5-8)	Same

Vehicle Systems' initial recommendation noted in 2.4 was for an air motor drive attachment fitted to the side of the GPU. This scheme was dropped when further evaluation revealed that:

- (1) The air motor drive was soft, requiring a relatively large initial throttle displacement to overcome start inertia, which must then be reduced for slow running. In close quarters this lack of precise control could cause the GPU to collide with the aircraft. This problem has been recognized in the A/M32-A60, and is serious enough that the drive system is disconnected on receipt by the using command.

- (2) The air motor is a relatively expensive device and the cost is not consistent with the balance of the GPU.

Hydraulic drives similar to those used on the MSU-1 were evaluated. Live axle designs using: (1) a single drive motor and differential, and (2) a simple offset gearbox, and simple gerotor type direct-drive hydraulic motors were evaluated. The direct-drive gerotor motor provided by Char-Lynn division of Eaton Corporation was found to be lightest, cheapest, and, by its simplicity, the most reliable drive scheme. In evaluating the mobility system, it became apparent that no objective justification for the self-propelled GPU could be made since the simple towed device was lighter, cheaper, and met all mobility requirements. The mobility equipment trade-off chart, Table 19, illustrates the selection basis.

### 3.2.8 Power Plant

This section describes characteristics of the power plants considered. The ultimate power plant selection was made on the basis of its relationship with driven accessories, and is discussed in Para. 3.2.14.

As noted in Para. 2.4.1, both diesel and gas turbine power plants were considered for this study. Even though the diesel engine was heavy, required a large volume for installation, had poor mobility, and demonstrated poor reliability and high maintenance requirements, it was felt that the fuel economy and low initial cost might offset these disadvantages.

The gas turbine, on the other hand, had the advantages of low weight, high mobility, and low volume, but these were offset by relatively high fuel consumption and higher first cost.

Gas turbines that were finally considered were integral-bleed, and of the single-pad type, as represented by the UTTAS or AAH APUs, and the dual-output pad type. Two output pads were required to turn at speeds of 6000 and 12,000 rpm for compatibility with the hydraulic pump and high-speed alternator. Therefore, the single-pad gas turbines had to include a two-pad auxiliary gearbox.

Diesel engines considered were all Army inventory hardware selected from QPL 11276. These engines operate in the range of 1800 to 2500 rpm, thus creating a problem of driving relatively high-speed accessories (6000-rpm hydraulic pump, 3600-to 6000-rpm alternator, and 30,000-rpm boost compressor) with the low engine input speed. Several approaches were considered in the diesel prime mover evaluation. The auxiliary

TABLE 19. MOBILITY EQUIPMENT

	Weight (lb)	Relative Volume	Mobility	Relative Cost (3)
Skid Mounted	20	Least (1)	0	
Solid Axle	292	(2)	Meets Spec	1
Sprung Axle	353	(2)	Meets Spec	2
Self Propelled (Solid Axle)	393	(2)	Exceeds Spec	3

95

- (1) The skid mounted system mobility requires use of a trailer or fork lift. M101 trailer weight is 1340 lb and volume is 210,936 in.<sup>3</sup>.
- (2) System volume is same for all three configurations.
- (3) Relative cost is rated from lowest, 1, to highest, 3.

gearbox arrangement used with the gas turbine overcame the diesel low-speed problem. Two basic diesel approaches, identified as mechanical links, were gearbox driven and considered using (1) the aircraft alternator for commonality with the aircraft systems, and (2) the low-speed commercial alternator. The advantages of the two systems were weight and cost, respectively. In addition to these mechanical link approaches, all-electric, all-hydraulic, or all-pneumatic drive systems for the diesel were also considered. In the all-electric system, a 100-KW low-speed alternator was driven directly from the diesel engine output shaft. Small (40 hp) electric motors were used to drive the hydraulic pump and air compressor to provide system hydraulic and pneumatic outputs. The all-hydraulic system was basically identical except that an 80-gpm, 3000-psi, hydraulic pump was driven directly from the diesel engine output shaft, and 40-hp hydraulic motors were used to drive the load compressor and alternator. The pneumatic system provided a direct drive air compressor that drove the hydraulic pump and alternator through air motors. Other potential combinations of hardware were available. However, the seven systems considered, i.e., five diesel and two gas turbine engines, represented the most economical arrangements in each of the drive systems.

### 3.2.9 Auxiliary Gearbox

Both the mechanical link diesel engine-driven systems and the single output pad gas turbine systems mentioned in the preceding paragraph required use of an auxiliary gearbox to provide the two- or three-output drive capability required to satisfy system output characteristics. Two approaches were followed in evaluating the auxiliary gearbox: (1) soliciting outside vendor interest in providing this kind of equipment, and (2) evaluation within AiResearch, since AiResearch has considerable expertise in the development and production of gearbox systems.

Cotta Transmission Company was contacted and indicated an interest in this program. Unfortunately, the responses were not received in time to use in the original evaluations leading up to the program review with Army personnel. Material from Cotta Transmission Company was based on a unit then in production. It would be adaptable either to a gas turbine or a diesel engine. However, the diesel engine would require additional gearing to adjust the speeds. The gas turbine engine driven device would have two output pads, both conforming to MS 18054. The input would be a pad similar to AND 20002. The gearbox, which would weigh approximately 200 pounds, would be based on an aluminum casting. The diesel engine-driven gearbox would be identical in output to that provided for the gas turbine. Additional gears would be

required to obtain the proper output speed, thus the weight would increase by about 50 pounds and cost by about 10 to 15 percent.

Since the Cotta response was late, AiResearch initiated a backup program to provide a preliminary gearbox design layout to be used on gas turbine engine-driven equipment only. The box would fit with either the standard AND 20002 pad or with the modified output pad anticipated for use on the AAH APU. The modified AAH APU pad was designed to fit with the friction clutch through which the APU drives into the helicopter gearbox. These layout schemes are shown in Figures 18 and 19. The AiResearch design approaches were significantly different from those used by Cotta Transmission Co. Cotta gearboxes were of industrial design using heavy low-strength shafts, large slab gears, and thick-walled aluminum castings. These features allow a low-cost, but high-weight part. AiResearch designs, on the other hand, are of aircraft quality, using high-strength steel gears, lightweight hollow shafts, and thin-walled aluminum castings. The estimated weight of the AiResearch gearbox was 50 pounds, compared with 200 pounds for the Cotta. However, AiResearch gearbox costs would be somewhat higher. Estimated prototype cost of the Cotta Transmission gearbox was about 60 percent of that for the AiResearch gearbox.

One other significant cost factor associated with the design, development, and test of an auxiliary gearbox was the nonrecurring task. In addition to the basic design, substantial nonrecurring cost for test and qualification would also be required. The large nonrecurring cost was felt to be inconsistent with the program hardware goals of using developed off-the-shelf equipment.

The AiResearch design was used in the trade-off discussed in Para. 3.2.14.

### 3.2.10 Installation

In the installation design considerations, the parameters of weight and volume of the selected components were fixed, and these established system mobility characteristics. Therefore, the only flexibility in the design was configuring the package to minimize enclosure dimensions. An enclosure could be configured so that no internal space was wasted; however, such an arrangement would generally be impossible to maintain and reliability would be poor. As a result, reliability, maintainability, and cost were felt to be the most significant design parameters. Specific tasks considered in the installation design included compartment cooling, exhaust isolation, acoustic treatments, inlet and exhaust location, inlet filtration, hydraulic oil cooling, and compressor inlet air treatments.

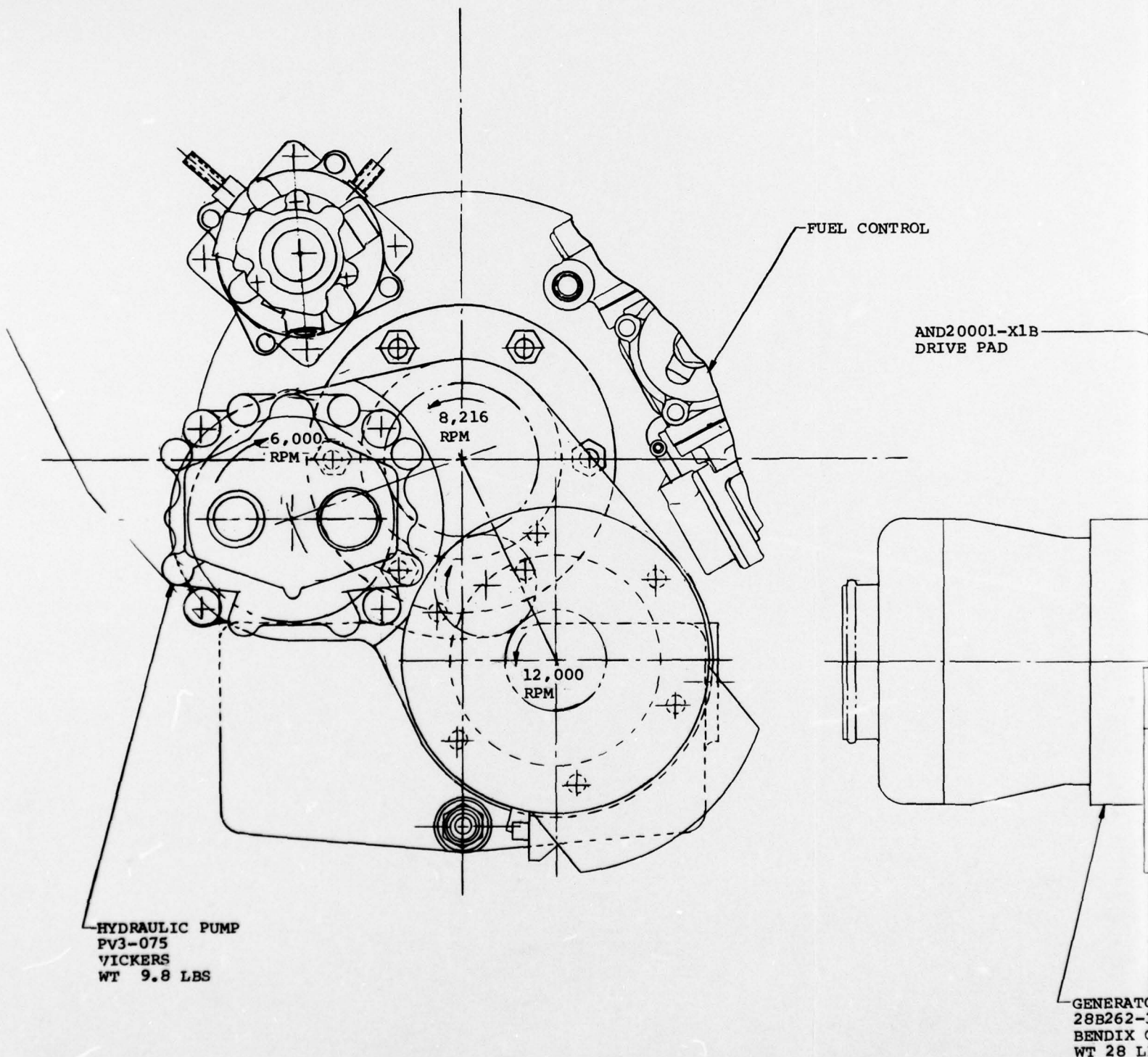
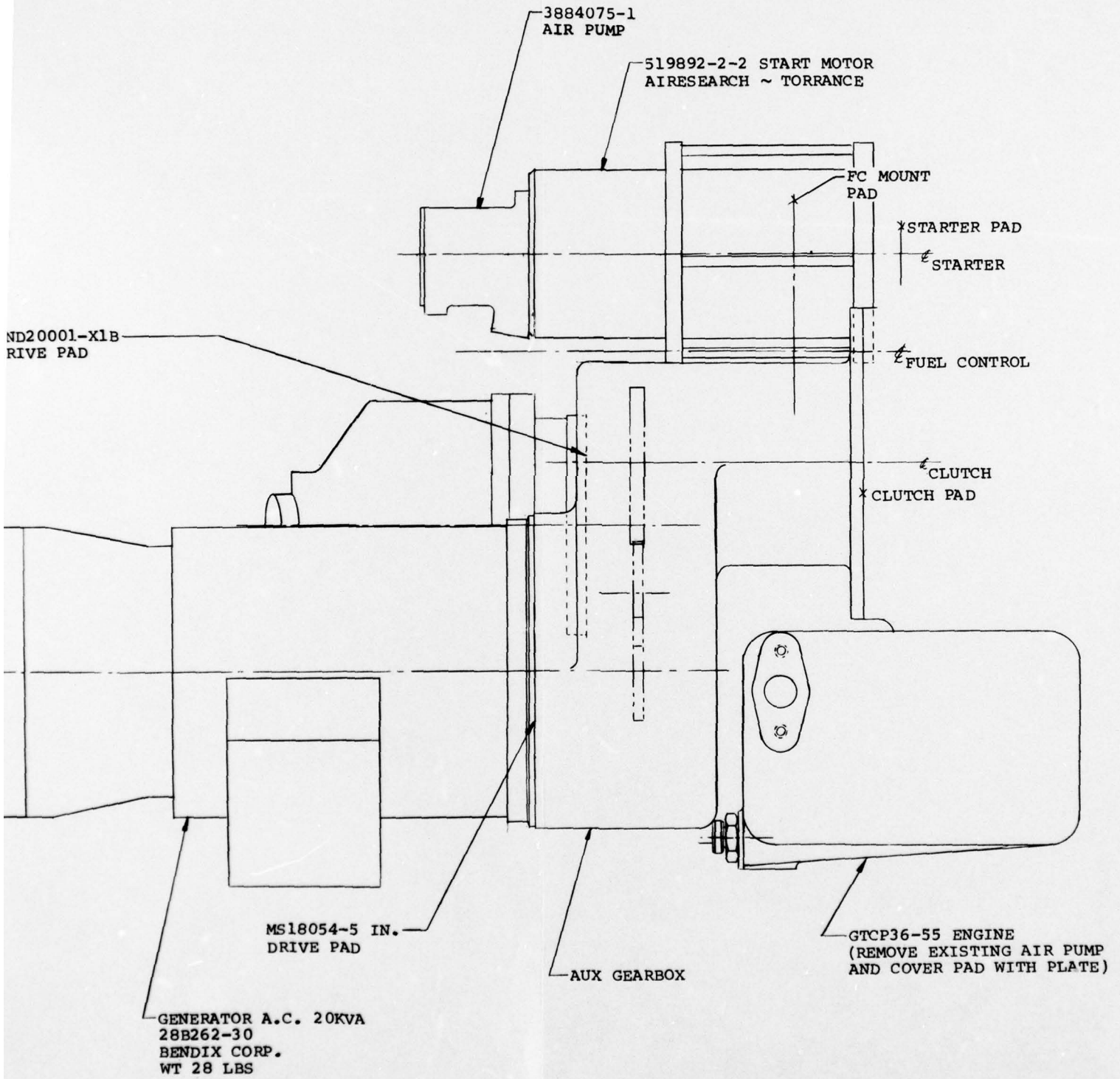
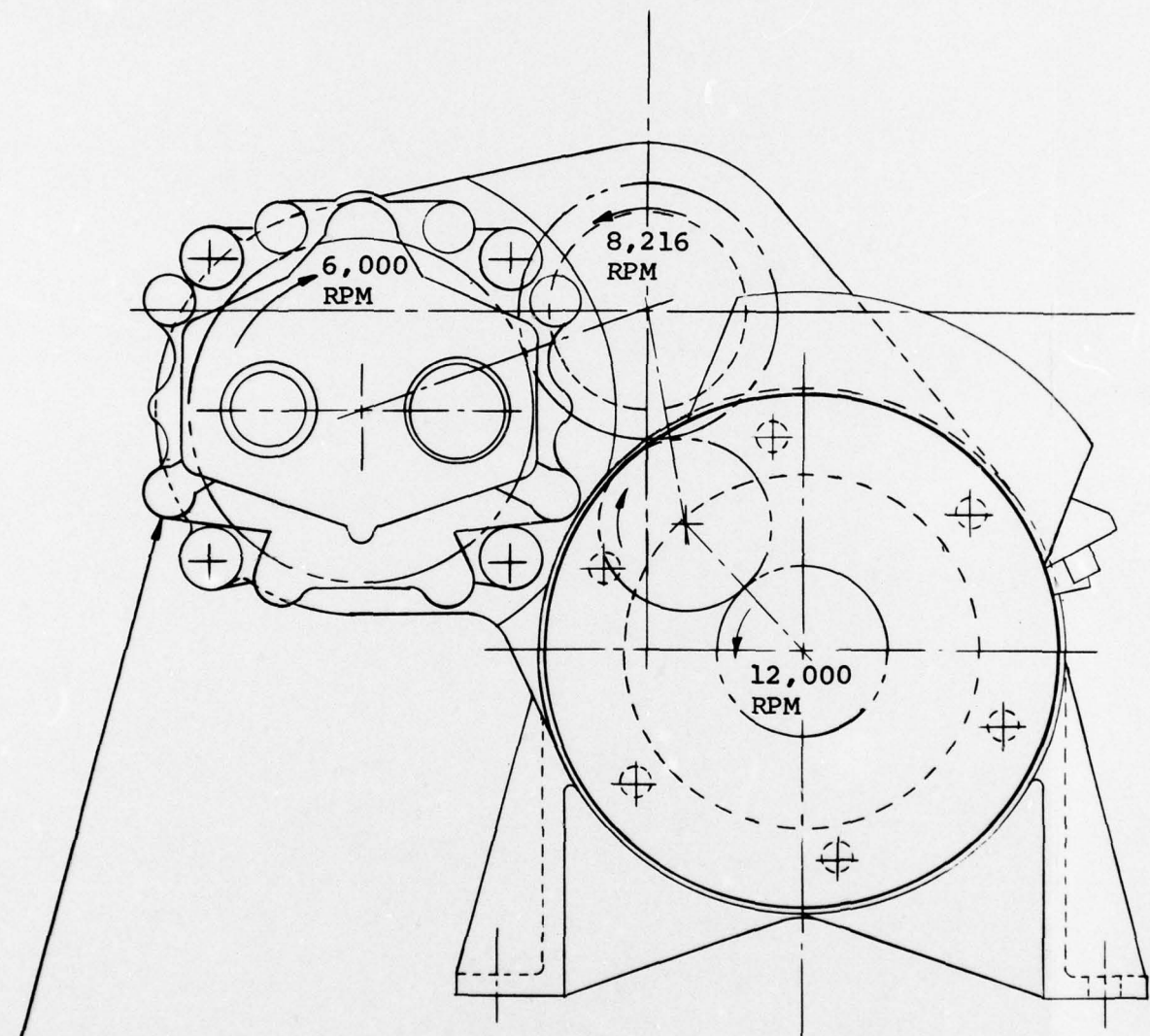

Figure 18. Two-pad auxiliary gearbox, advanced ground power unit.





2



HYDRAULIC PUMP  
 PV3-075  
 VICKERS  
 WT 9.8 LBS

Figure 19. Clutch-driven two-pad auxiliary gearbox.

PRECEDING PAGE BLANK-NOT FILMED

AND20001-X1B  
DRIVE PAD

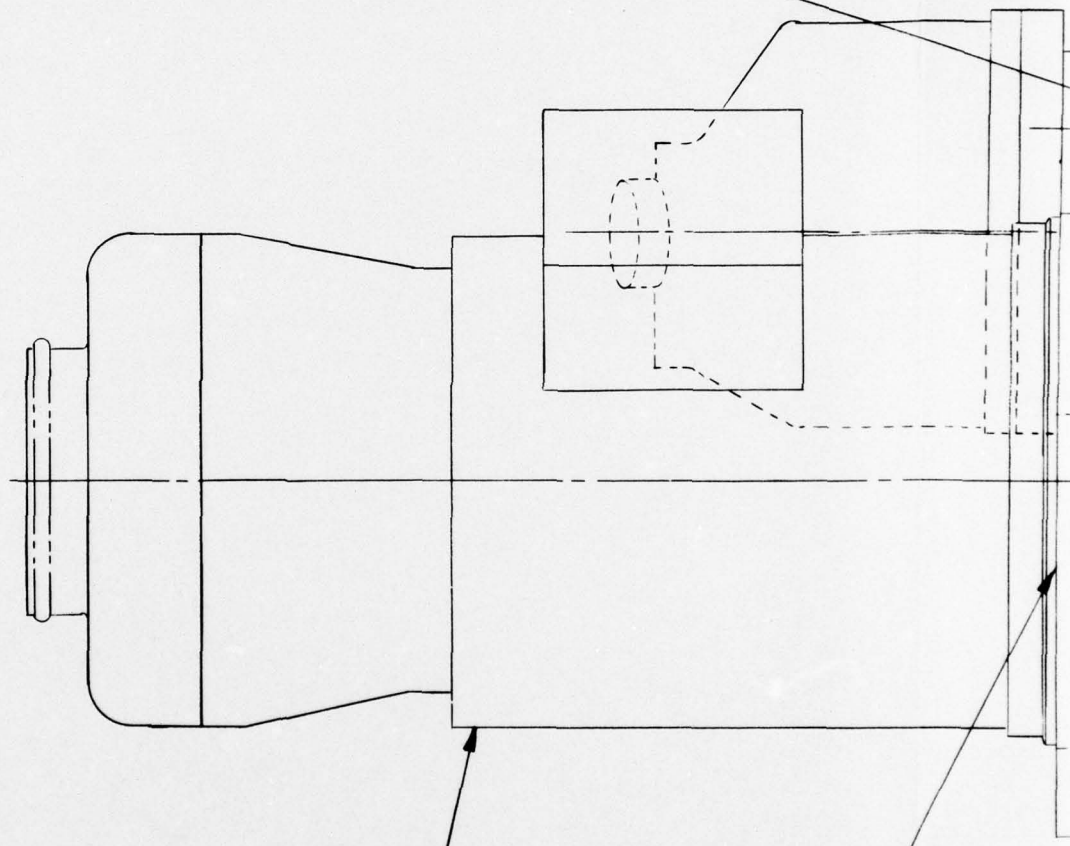
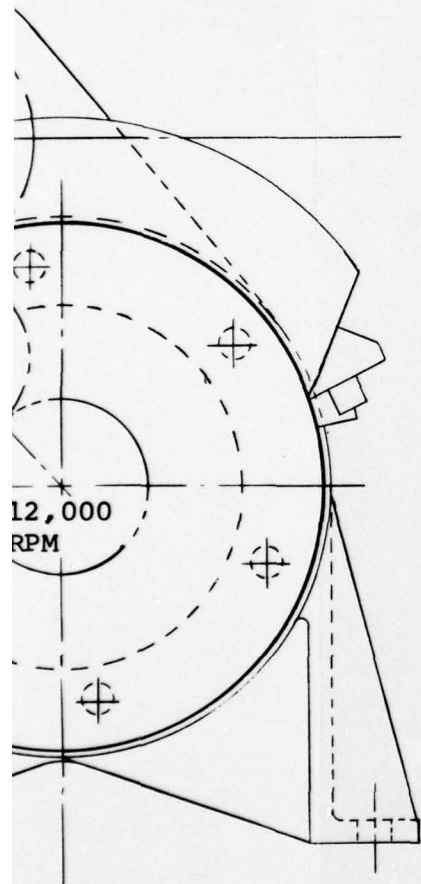

MS18054-5 IN.  
DRIVE PAD

GENERATOR A.C. 20KVA  
28B262-30  
BENDIX CORP.  
WT 28 LBS

ry gearbox.

2

AUX GEARBOX

CLUTCH ASSEMBLY  
(PART OF GTCP36-55 ENGINE  
ASSEMBLY NO. 3800034-1)

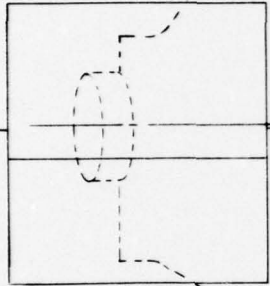

MS18054-5 IN.  
DRIVE PAD

GENERATOR A.C. 20KVA  
8B262-30  
ENDIX CORP.  
WT 28 LBS

3

A detailed installation analysis was undertaken as a part of the MERADCOM 30-KW generator set program. The generator set and GPU were basically identical. Therefore, the previously conducted parametric analysis was felt to be valid for this program. Results of this analysis are shown in Table 20. Installation selection was based on minimum specific fuel consumption (SFC) penalty. It should be noted that Configurations B and G both introduce a lower SFC penalty on the installed gas turbine than the selected Configuration H. Configuration G was selected for the MERDC 30-KW system. The difference between G and H was that inlet air to the gas turbine and to the generator is ducted in Configuration H, whereas it was not ducted in Configuration G. The ducted inlet system was felt to be more appropriate for the GPU since bleed air extracted from the GPU power plant would be used in the AAH aircraft environmental control systems and must be breathable. For this reason, it was felt that the contamination that might occur within the enclosure would be unacceptable. Accordingly the inlet plenum and duct were selected. Configuration B required use of an engine-driven fan. Since no fan drive pads were available on the gearbox of the selected GPU power plant, this was not a viable system.

Compartment cooling in the installation arrangement was provided by an exhaust gas ejector. Primary flow was from the turbine exhaust taken from the engine exhaust duct into a transition turn that redirected air from the 6-in. round exhaust duct into a 2-x 14-in. rectangular duct, and then through a 90-degree turn to discharge vertically upward. The high velocity, high temperature exhaust jet was used as the motive force for an exhaust gas eductor. Previous AiResearch experience with eductors of this type indicated that a primary-to-secondary flow ratio approaching one may be obtained. Secondary flow was used for compartment and hydraulic oil cooling, as well as cooling and reducing turbine exhaust velocity. This feature also provided advantages in acoustics and infrared (IR) signature.

The control system and electrical components should be isolated from the hot turbine area. This isolation could be accomplished by use of the shrouded exhaust arrangement chosen or a firewall. The shrouded exhaust was chosen since it significantly enhanced maintainability of the generator set. The hot turbine exhaust components were shrouded in a flow of cool air induced by the exhaust gas ejector. The extremely hot turbine exhaust was exposed only to the internal components of the exhaust shroud. Acoustic treatments would be addressed in a separate item; however, acoustic treatments generally were incorporated as a part of the overall installation design to provide the most optimum arrangement meeting the general

TABLE 20. INSTALLATION PARAMETRIC ANALYSIS

System Parameters	System Configurations									
	Firewall Design (Base)	A	B	C	D	E	F	G	H**	
Inertial Filter (small to large) (sizes 1, 2, and 3)	1	1	1	1	2	3	3	1	1	
Inlet Duct/Plenum	-	Yes	Yes	-	-	-	-	-	Yes	
Generator Inlet Duct	Yes	Yes	Yes	-	-	-	-	-	Yes	
Inertial Filter (Bleed Air Requirements)	1	1	1	1	2	3	3	1	1	
1 Filter No. 1										
2 Filters No. 2										
3 Filters No. 3										
Firewall or Shrouded Exhaust (F)	F	S	None	S	S	S	S	S	S	
Engine Driven Fan	-	-	Yes	-	-	-	-	-	-	
Eductor Stack	Yes	Yes	-	Yes	Yes	Yes	Yes	Yes	Yes	
Exhaust Stack w/o Eductor	-	-	Yes	-	-	-	-	-	-	
Oil Cooler Duct	-	-	-	yes	Yes	Yes	Yes	-	-	
Maintainability	2	1	1	1	1	1	1	1	1	
1. Good										
2. Poor										
Eductor SFC Penalty	1.904	1.404	0	1.638	1.630	1.638	1.404	1.170	1.170	
Filter Scav. Flow SFC Penalty	0.675	0.675	0.675	0.675	0.837	1.013	1.013	0.675	0.675	
Inlet Heating (at 3°F) Penalty (at 50F)	0.300	-	* 0.300	0.300	0.300	0.300	0.300	0.300	-	
0.500			0.500	0.500	0.500	0.500	0.500	0.500	-	
Inlet Duct SFC Penalty	0	0.500	0	0	0	0	0	0	0.500	
Total SFC Penalty at 3°F	2.379	2.579	1.675	2.613	2.775	2.951	2.717	2.145	2.345	
Total SFC Penalty at 5°F	2.579	2.579	1.673	2.813	2.975	3.151	2.917	2.345	2.345	

\*Incr. SFC due to fan power input

\*\*Selected system

requirements of reliability, maintainability, and cost. Both inlet and exhaust were located on the towbar end of the set, away from the operator's console. The inlet was located above the towbar in a wide duct, extending across the end of the enclosure. The turbine exhaust discharges vertically upward at the same end. This was felt to be the best arrangement for a number of reasons: the inlet and exhaust are both located as far as possible from the operator's station; this arrangement affords the best separation of inlet and exhaust to prevent reingestion of hot exhaust; the inlet is high enough above the ground so that no "vacuum cleaner" effect would take place; the turbine exhaust is placed high in the enclosure, thus minimizing safety hazard.

In every mobile gas turbine system, location of inlet and exhaust ducting represents a compromise in the installation. The arrangement chosen for the GPU was felt to offer the least possible compromise to other factors in the system design.

An inertial inlet air filter is provided as a part of the installation. This device is believed to be mandatory in a piece of ground servicing equipment requiring high reliability and long life. The particular filter selected for this design is available from either the Donaldson Company or Aircraft Porous Media. Technical features of efficiency and installation requirements are almost identical between the two systems. No production cost data has been accumulated; however, based on previous experience, the two companies would be extremely competitive.

The inlet filter functions by inducing a swirl component through a series of small diameter tubes (approximately 1-in. diameter). The swirl or centrifugal separator effect generated in these swirl tubes tends to sling the heavy dirt particles to the outer film of air passing through the tubes (see Figure 20). Downstream of the swirl tube is a receiver slightly smaller in diameter than the swirl tube. This receiver skims off the dirty air, allowing only clean air to pass through. Dirty air is drawn through an ejector system to an exhaust port in the installation. In the GPU, this filter scavenge arrangement is accomplished by using the low pressure in the area surrounding the exhaust gas ejector as a filter scavenge medium. Penetrations into the inlet filter box are provided from the exhaust box so that contaminated inlet filter air may be drawn away. Filter efficiency is on the order of 90 percent with A.C. coarse dust and 85 percent with A.C. fine dust, with air contaminated to the level specified in MIL-E-5007.

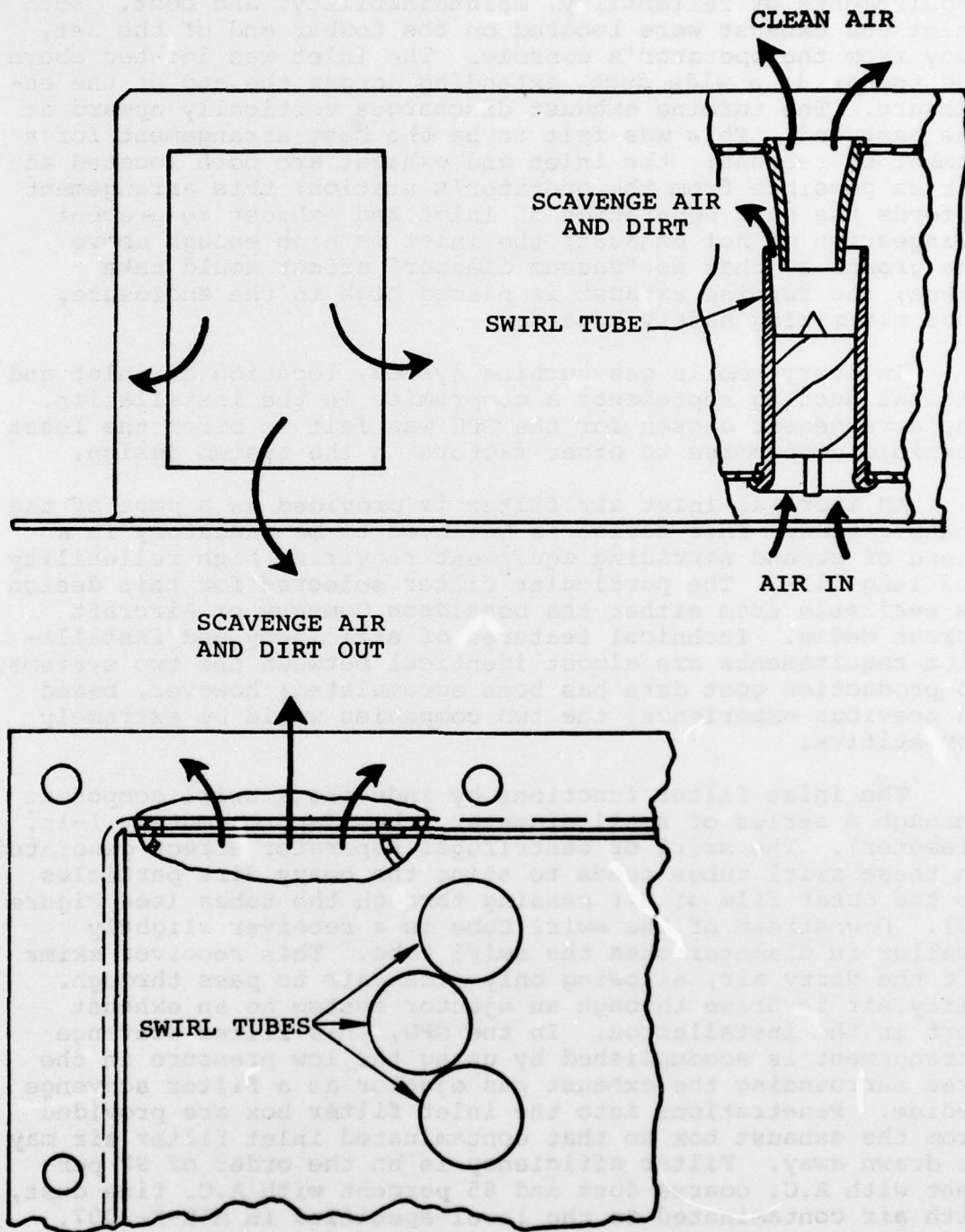

Figure 20. Inertial inlet air filter diagram.

Hydraulic oil cooling is another byproduct of the exhaust gas ejector system selected for this installation. Hydraulic oil filters were mounted in the enclosure wall with a simple deflector and acoustic baffles on the inside of the enclosure to present direct line of sight into the enclosure. Compartment cooling airflow is initially drawn through the hydraulic oil coolers, over the temperature-sensitive control system components, and into the turbine exhaust box.

The inlet plenum and duct arrangement provide a crushable elastomeric seal between the compressor inlet plenum and inlet duct in the GPU enclosure. The inlet duct is a formed element in the bottom pan of the fiberglass enclosure. The inlet plenum is a separate gas turbine component. The inlet plenum provides a flow of clean, uncontaminated air from the outside ambient, through the inertial inlet air filter, and directly to the gas turbine compressor. An airflow schematic is shown in Figure 21.

### 3.2.11 Instrument Panel

The GPU instrument panel is laid out with the instrumentation arranged in functional groupings. The gas turbine engine instrumentation includes the exhaust gas temperature (EGT) indicator, tachometer, hourmeter, and battery charge indicator. Controls included in this group are the dc circuit breaker, panel light switch, and gas turbine master/start-stop switch. The second group includes the hydraulic system and pneumatic system. Each of these systems consists of a pressure gage, a function light to indicate that the system is in operation, and an on/off selector switch. The third grouping comprises electrical instruments, including the frequency meter, volt meter, ammeter, and a space for dc volts and dc amps if it is ultimately decided that these instruments are required. Controls included in these groupings are the ac circuit breaker switch and indicator light, ac voltage adjust rheostat (later deleted), volt amp transfer switch, and dc circuit breaker switch and light. The fourth grouping is the fault isolation panel. This device receives a fault signal from one of the sensing devices provided in the GPU either from the gas turbine logic package or the electrical or hydraulic system warning functions, provides a shutdown function, and automatically lights the appropriate fault warning light on the indicator panel. Both are latching functions. If a fault causes gas turbine shutdown, the shutdown is latched such that the unit may not be restarted without clearing the fault panel. At the same time, the first fault that occurs lights the appropriate indicator light on the fault isolation panel and then blocks any subsequent fault shutdown indications. Faults appearing on the fault isolation panel include overspeed, electrical shutdown, loss of fuel, control system short circuit,

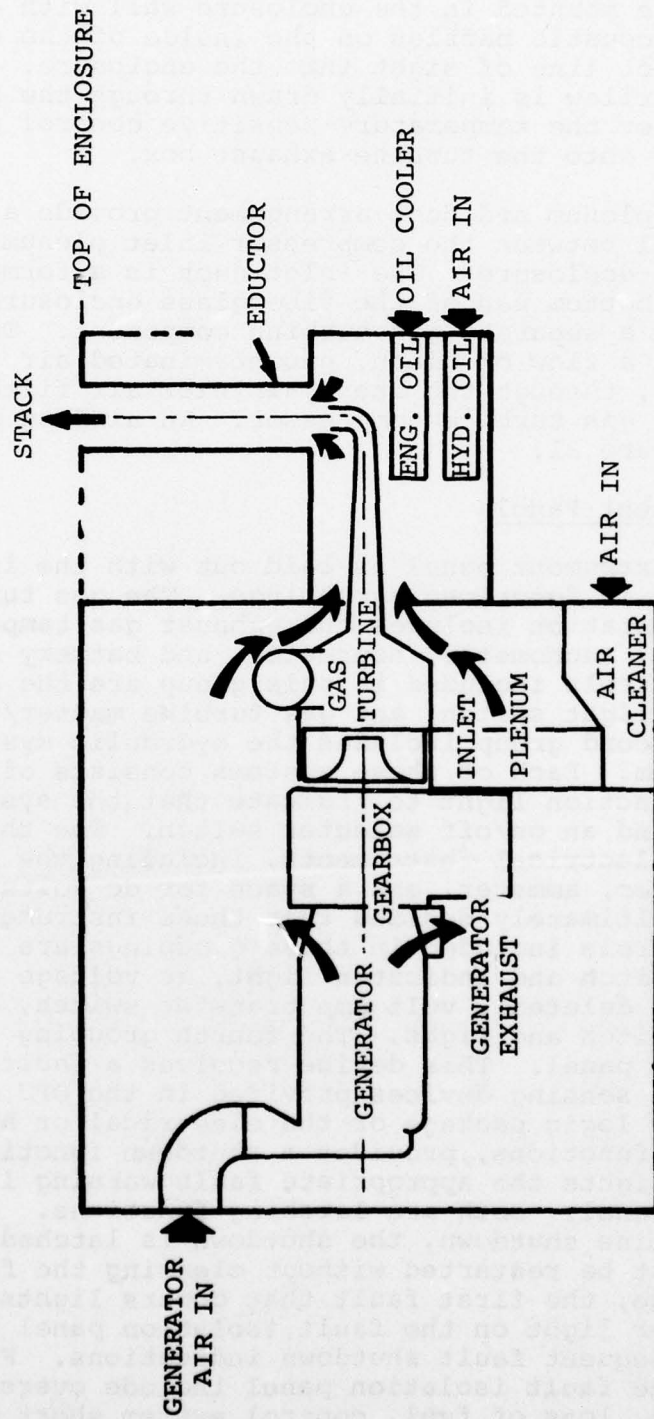

Figure 21. Airflow schematic, Army advanced GPU.

high oil temperature and low oil pressure. Warning functions are also provided to alert the operator of pending problem areas. These four functions are battery fault, low fuel, high EGT, and hydraulic fluid high temperature. These functions are not lockout-type and reset independently when the fault condition is removed. Also included on the fault indicator panel are the test-reset switch and indicator light. The initially proposed instrument panel layout is shown in Figure 22.

### 3.2.12 Acoustics

The contract SOW established an objective of 50 dB at 10 feet as the GPU allowable noise level. Subsequent to issuance of the contract, this requirement was relaxed such that 50 dB became a design goal. It was originally pointed out in the AiResearch GPU program proposal that 50 dB was an ambitious requirement which was beyond the current state of the art for existing off-the-shelf equipment. AiResearch suggested that 50 dB could be obtained by incorporating acoustic suppression characteristics in the basic aerodynamic component design, and therefore suggested that an effort in the advanced APU portion of the GPU concept contract could be extended to include attaining the 50-dB noise level goal.

Some evaluation of the single-point noise level requirement was felt to be in order. A simple single-point overall statement could allow significant variations in the sensible noise as heard by the human ear. Standard practice in the gas turbine industry is to specify the noise level over the audible frequency range using center frequencies of octave band frequency limits. This results in a curve statement as shown in Figure 23. A modification of this method that provides much closer approximation of the sensible noise uses a weighting network representing the acoustic response of the human ear. Figure 24 illustrates the "A" weighting scale, allowable octave band noise limits for diesel and gas turbine sets, and the single-point overall and A-weighted values for those limits. The main goal in establishing any acoustic specification is to fix noise generation characteristics of a piece of hardware as represented either by the noise tolerance of individuals working around the operating equipment or as a function of detectability of a piece of military equipment in a combat operating zone. A goal of 50 dB had been established in prior programs on the basis of the detectability criterion. Both civilian and military agencies have established standard limits that govern the allowable noise outputs of equipment for human tolerance. These are specified in the OSHA requirements, in MIL-STD-1474, and in other documentation dealing with military hardware. The main concern was the cost of acoustic treatment in weight and dollars to accomplish a

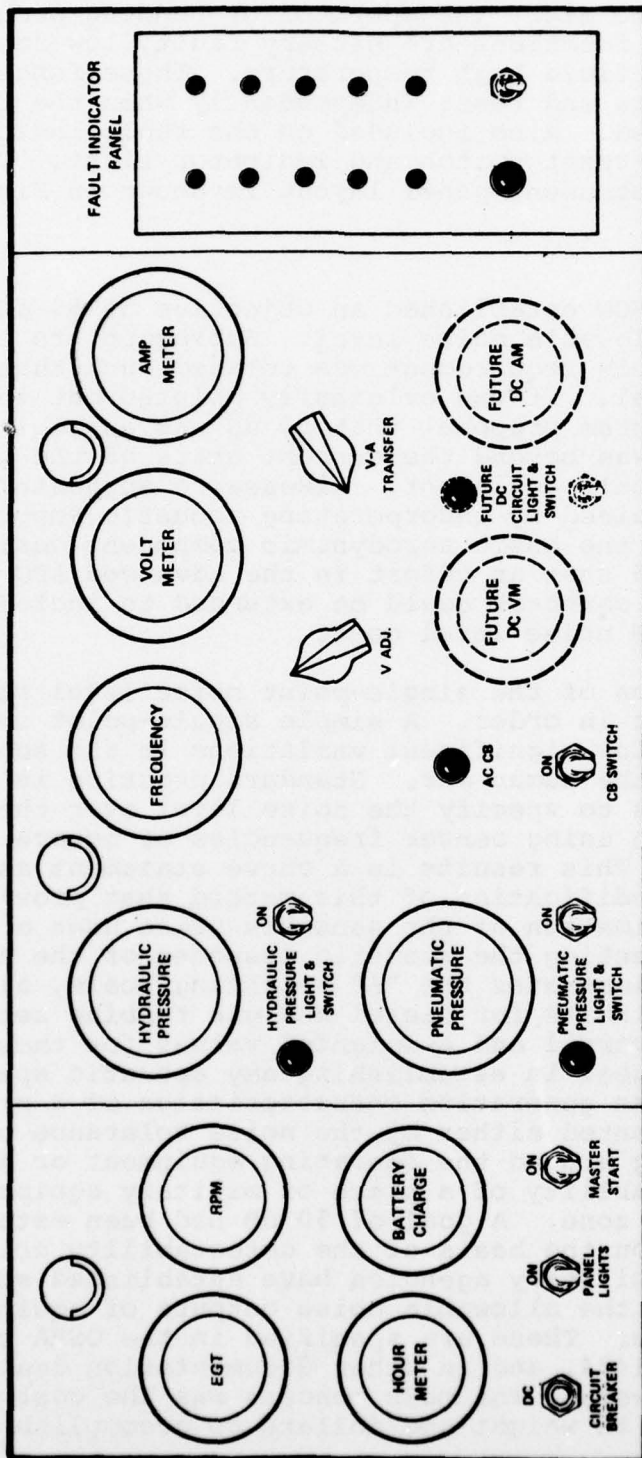

Figure 22. Instrument panel layout.

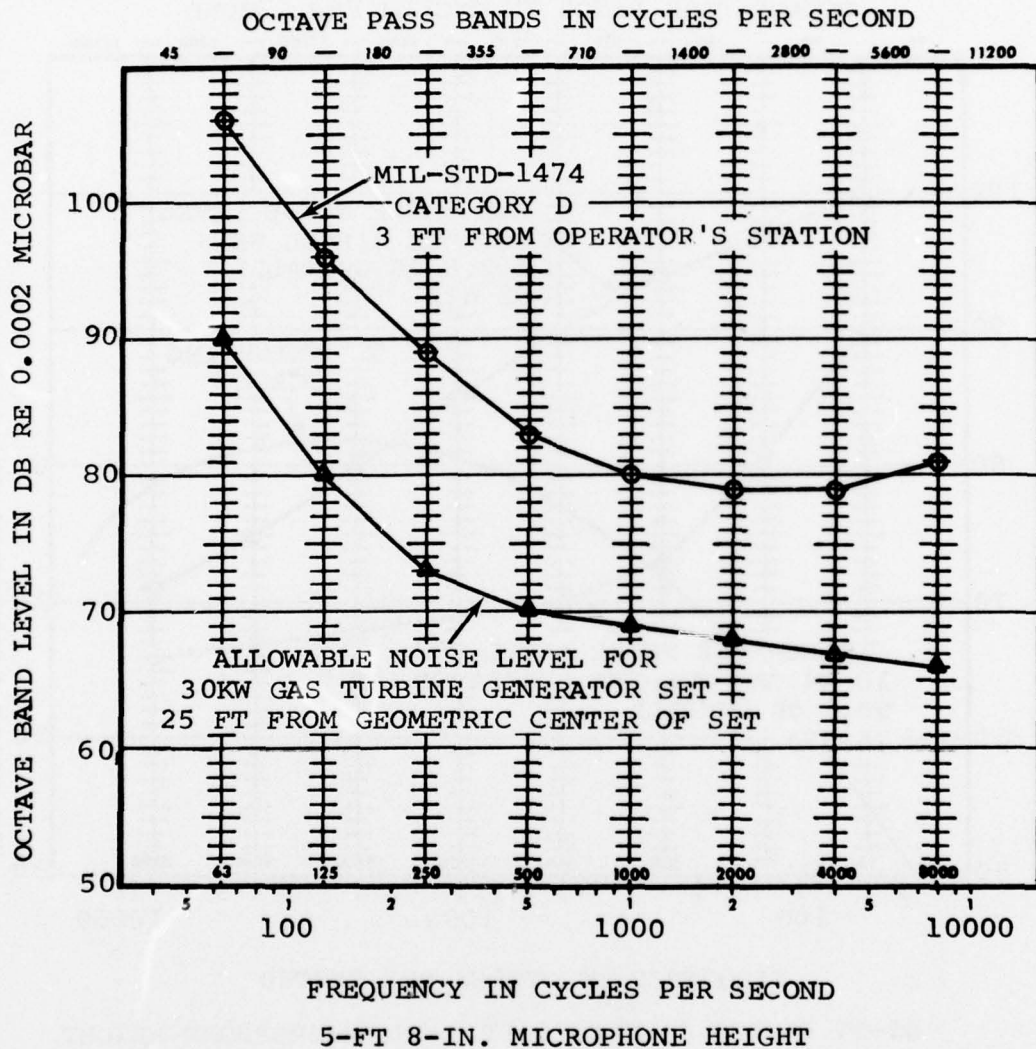
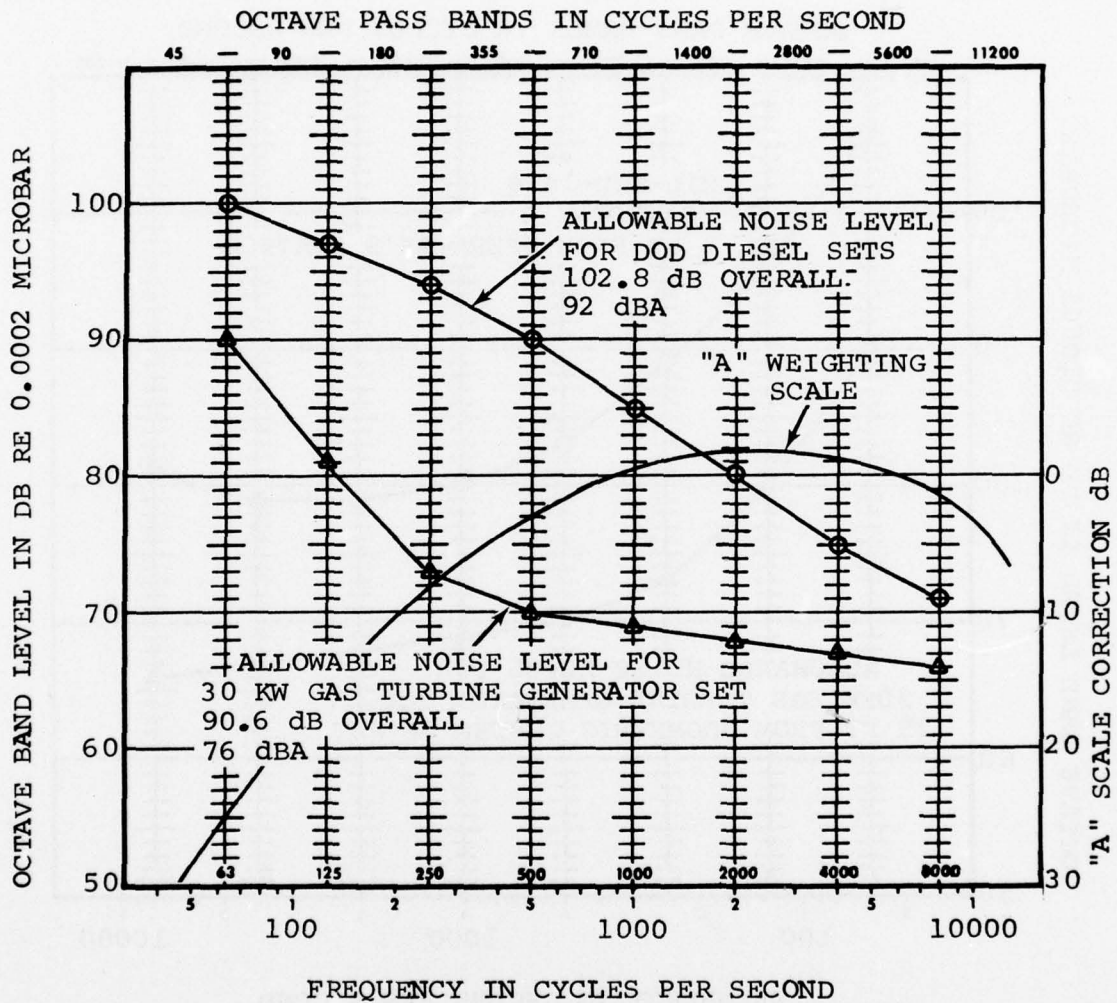

Figure 23. Comparative noise characteristics.



25-FT RADIUS CIRCLE, 5-FT 8-IN. MICROPHONE HEIGHT

Figure 24. Comparative noise characteristics.

specified level of quietness. A chart was prepared illustrating general characteristics and relative cost and weight to accomplish overall noise levels of gas turbine driven equipment. In this particular case the advanced GPU was used as a model. In Figure 25, seven points are established on the curve representing increasingly quiet installations. Point one represents only an enclosed bare gas turbine with no inlet or exhaust silencing incorporated. A sound pressure level (SPL) of 98 dB overall is noisy to the point of discomfort. Point 2 represents the same unit with inlet and exhaust silencing added. This drops the overall noise from 98 to 82 dB. Point three provides an additional 1-dB reduction by adding a straightening grid in the turbine exhaust. The configuration represented by Point 3 was chosen and depicted in the layout sketches defining the GPU as presently conceived. The balance of the configurations noted, 4 through 7, significantly increase the package envelope to accomplish the stated noise reduction. A point worthy of some consideration is the weight. The vertical weight of Figure 25 scale is not linear, and the 10 dB change realized by the next step in treatment providing additional enclosure treatments and an inlet and exhaust maze imposes an added weight penalty of 650 pounds and a relative cost three times that of the chosen system. The main point illustrated in this chart is that, with the addition of enough material and its attendant weight and cost increases, an extremely quiet system could be developed; however, this quietness would necessarily be traded off against weight, cost, serviceability, and usability of that piece of hardware. As noted, the treatment represented by Point 3 on the curve is the treatment selected for use in the advanced GPU. A total of 81 dB overall is a relatively quiet, tolerable noise level. To illustrate this noise level, reference has been made both verbally and audibly to the MERADCOM 30-KW generator set that was produced at AiResearch. The proposed treatments and anticipated noise levels are represented by that piece of hardware.

### 3.2.13 Infrared Radiation

No infrared (IR) requirements were established for the GPU in the SOW. However, it was felt that because of the proximity of the laager area, where the GPU is envisioned for widest usage, to the battle area there was a potential for the GPU system to be exposed to infrared seeking devices. Also, because of the GPU proximity to the aircraft, a potential hazard to the aircraft itself was present. For this reason, an investigation was conducted to establish IR characteristics of the GPU and to determine if any modifications not requiring complete redesign of the GPU system could be implemented to reduce the IR characteristics.

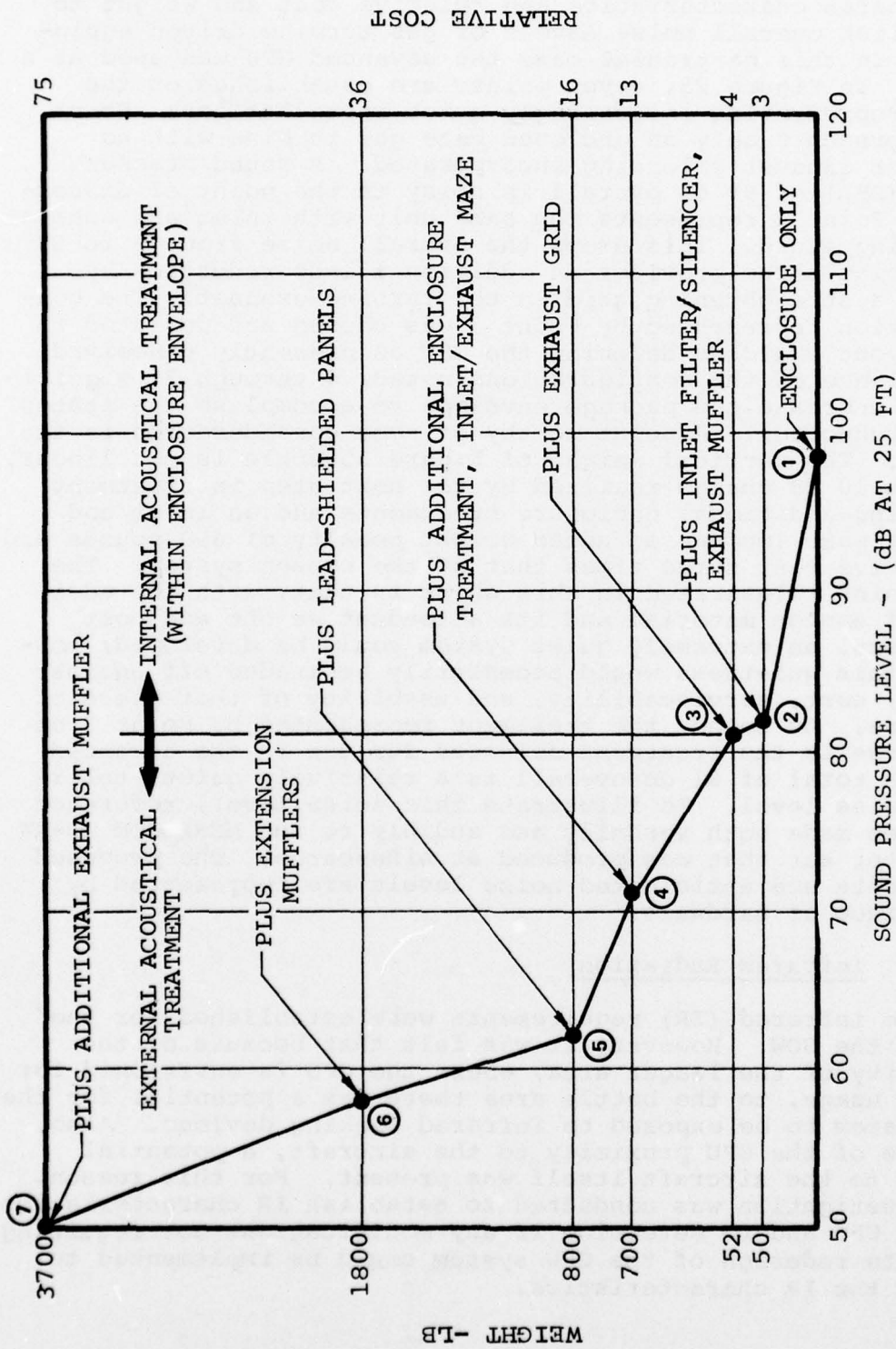

Figure 25. Acoustic treatment cost and weight penalties.

RELATIVE COST

WEIGHT - LB

The gas turbine IR signature consists of two elements: the exhaust plume, which is a cloud of hot gas ejected from the turbine exhaust into the atmosphere; and the hot metal parts associated with the turbine exhaust (see Figure 26). Other installations might have other sources, but these two are the primary concern in the GPU. For evaluation purposes, a full-load exhaust gas temperature of 1275°F was assumed at a flow rate of 3.35 lb/sec. As noted in the installation section, the unit employs an exhaust gas ejector to provide compartment cooling. If an ambient temperature of 100°F is assumed with a secondary flow rate of 3 lb/sec, a mixed gas temperature of 710°F is projected from the turbine exhaust. This 710°F plume provides a hot gas signature of 10 watts per steradian. The hot metal temperature is estimated to be 700°F. There are approximately 150 sq in. of material at this metal temperature, including the screen, the end of the exhaust muffler, and the turbine exhaust pipe that is visible through the screened opening. This area of hot metal has a signature of 35 watts per steradian. These values exceed the aircraft IR limits. However, design changes using mixing devices, cascade ejectors, or screens, can be incorporated to shield turbine exhaust components and hide hot metal parts sufficiently to satisfy IR requirements should they be imposed.

Inasmuch as no IR requirements have been imposed and the investigation ruled out the potential redesign requirement, no further investigation was conducted.

#### 3.2.14 GPU Selection

Hardware systems were established to present an array of choices associated with different power plants so that the total power generation system could be traded off and evaluated. The combinations ultimately considered for evaluation are shown in Table 21. As noted in the power plant description in Para. 3.2.8, combinations of diesel-engine-driven primary electric, hydraulic and pneumatic systems were established, as well as gearbox-driven, mechanically-linked systems using both commercial and aircraft quality hardware. Even with the best combinations of hardware available, the total rating values for all diesel systems were nearly twice that of the gas turbine configurations. The two gas turbine configurations shown in Table 21 used fiberglass enclosures and the selected components described in the detailed trade-off analyses of Para. 3.2. The auxiliary gearbox considered for the two-pad gearbox configuration was the AiResearch design, which was lighter but more expensive than the Cotta Transmission design that was received later. The optimum configuration, based on the trade-off information presented, is the gas turbine engine-driven, integral bleed, integral two-pad gearbox

PLUME - 10 WATTS/STERADIAN

710°F MIXED GAS TEMPERATURE

HOT METAL - 35 WATTS/STERADIAN  
700°F SCREEN AND  
PIPE

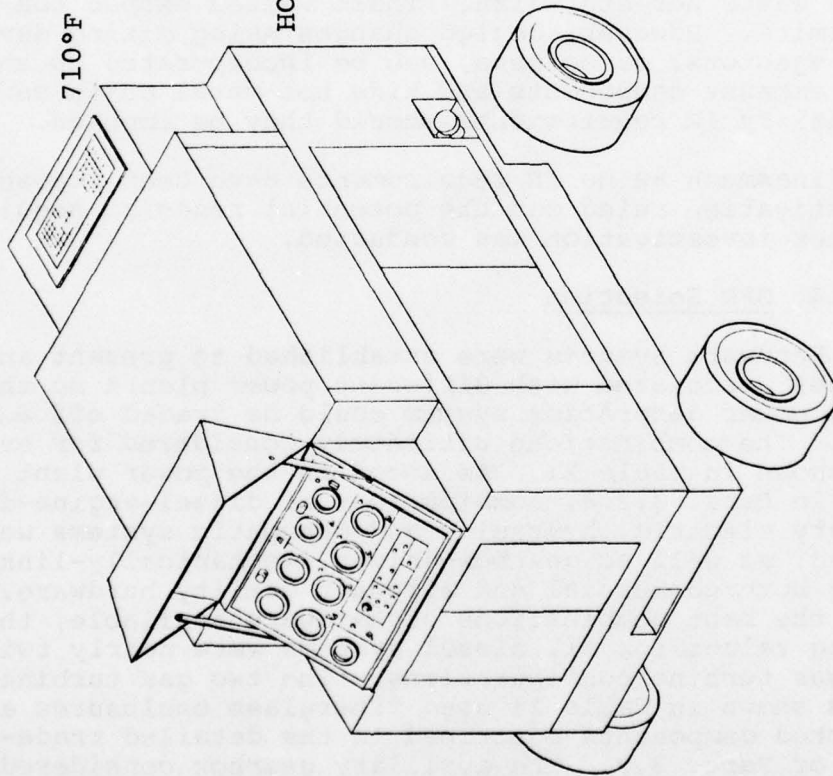

Figure 26. Infrared signature.

TABLE 21. GROUND POWER UNIT TRADE-OFF

System	Weight (lb)	Volume (in. <sup>3</sup> )	Relative Cost (2)	Reliab. (MTBF)	Maint.	Total
Weighting Factor	(2.0)	(1.8)	(1.5)	(1.2)	(1.0)	7.5
Diesel All Electrical	5646 10.04	253,368 4.32	2.02	394.5 2.00	+50% 1.5	19.88
Diesel All Hydraulic	4784 8.50	253,368 4.32	1.57	336.9 2.34	+50% 1.5	18.23
Diesel All Pneumatic	4656 8.28	253,368 4.32	1.5(1)	361.3 2.18	+50% 1.5	17.78
Diesel Mech. Link	5046 8.97	253,368 4.32	1.52	386.4 2.04	+50% 1.5	18.35
Diesel Mech. Link A/C Alternator	4224 7.50	218,376 3.72	1.52	386.4 2.04	+50% 1.5	16.28
G/T Int. Bleed Std 2-Pad G/B	1125(1) 2.00	105,600 1.80(1)	1.74	657.8 1.2(1)	1.0(1)	8.57
G/T Int. Bleed Aux 2-Pad G/B	1148 2.04	118,560 2.02	1.93	649.3 1.22	1.0	8.90

(1) Baseline Value

(2) Actual costs are vendor proprietary. Weighted values were obtained by multiplying percentile comparison of individual GPU cost with baseline cost by weighting factor of 1.5.

unit driving the hydraulic pump and high-speed alternator directly. The unit is housed in a fiberglass enclosure, and is mounted on high-flotation wheels and tires fixed to solid axles. It is a towed device. The gas turbine is electrically started.



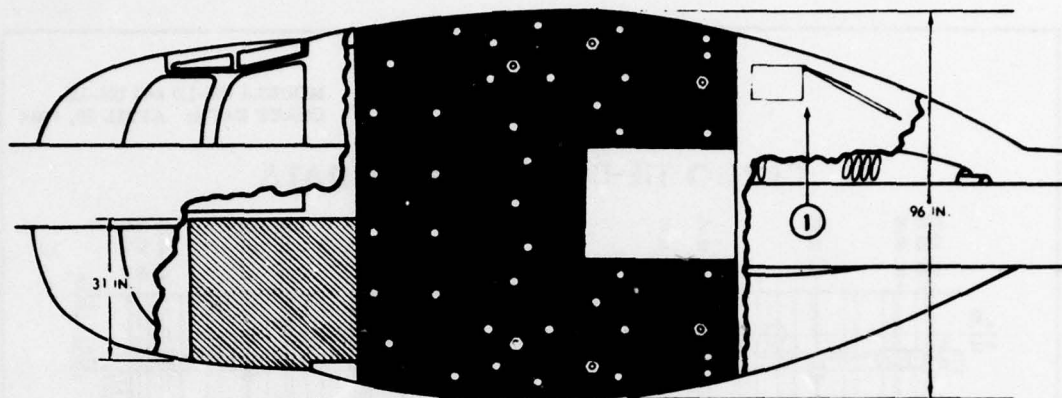

Additional features beyond those evaluated in the trade-off analyses were incorporated. Part of the transportability requirement established for the GPU was that it might be carried as an internal cargo load in the CH-47 and the C-130 aircraft, and as a sling load by the UTTAS, UH-1, or CH-47D. In reviewing the UTTAS aircraft procurement specification, it was noted that sling load cargo could be carried only in VFR conditions, and that IFR operation could be conducted with internal cargo load only. For this reason, the GPU was configured to be carried as internal cargo in the UTTAS helicopter. A layout sketch showing this installation was prepared by Vehicle Systems as part of the mobility study (Figure 5). Further review suggested that, although it was not a problem statement requirement, it would be desirable to have the GPU also stowable on-board the UH-1. Therefore, unit height was limited to 48 in. The UTTAS door opening is 52 in. high, while the UH-1 door opening is 49 in. high. The 48-in. GPU dimension will fit within either of the aircraft hulls. The GPU track over the outside of the wheels is 52 in. This dimension is also consistent with either aircraft cargo area. GPU length with the towbar folded up is 72 in., which again is a consistent dimension with the aircraft cargo areas. Tie-down provisions are available to accommodate the GPU in either aircraft model, and either aircraft floor will accommodate the unit loadings imposed by the tires. Cargo area and tie-down data for the UH-1 aircraft only are shown in Figures 27 and 28.

Stowage compartment for aircraft service conductors is at the top of the GPU, and is sized so that all service conductors (the bleed air duct, ac cable, and hydraulic hoses, each 30 ft long), could be stowed in this container during GPU transport. External service conductors stowage was not considered since loss in transport would be very likely. GPU system dry weight is 1175 lb. In addition, with each of the reservoirs full, the fluids would add an additional 244.5 lb. This is made up of 6 gal. of hydraulic fluid, 40 gal. of jet fuel, and 1 gal. of lube oil. System gross weight is estimated at 1484.5 lb.

An elementary electrical system schematic is shown in Figure 29. The hydraulic system schematic associated with the pressurized reservoir system is shown in Figure 30.



**CODE**

-  1 Tie-down Fittings
-  2 Stanchion Fittings
-  3 Cargo Area, Maximum Loading Dimensions
-  4 Optional Loading Area, Left Seat Removed
-  5 Interior Clearance Above Maximum Package at Center-line of Cabin

① Mirror Stowage

**NOTES:**

1. Cargo floor loading vs G load factor

Lb. Sq. Ft.	Safety factor
300	1.0
150	2.0
100	3.0

- 2. Floor tie-down fittings, strength 1250 pounds vertical, 500 pounds horizontal load per fitting. Each aft bulkhead tie-down fitting is capable of the following loads: 1250 lbs, parallel to the bulkhead, 2195 lbs at a 45° angle.
- 3. Bulkhead tie-down fittings are good for 2500 pounds ultimate per fitting perpendicular to the bulkhead.
- 4. Tie-down fittings on the side of the beams are good for 1250 pounds ultimate per fitting perpendicular to the beams.
- 5. Two fittings at station 129.0 are good for 1250 pounds ultimate per fitting perpendicular to bulkhead.

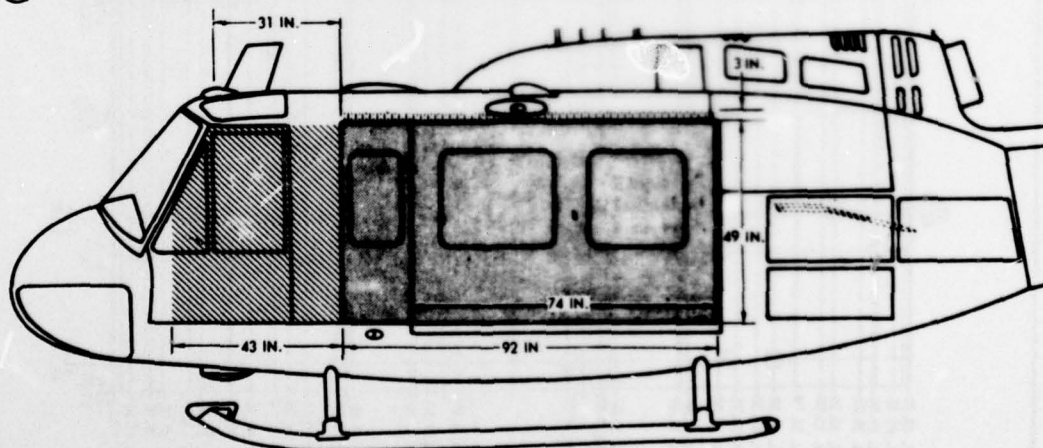
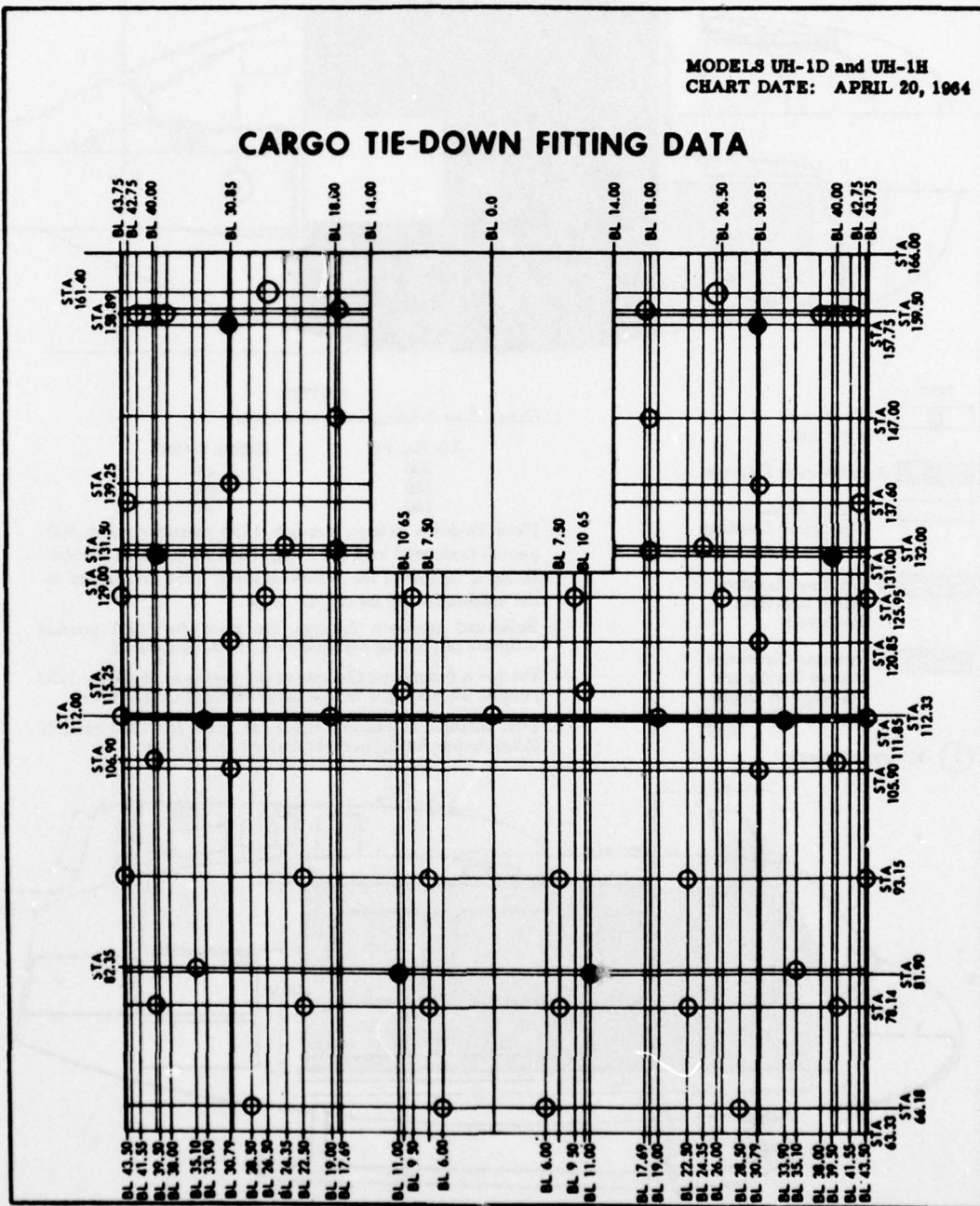

Figure 27. Cargo area and tie-down fittings.

MODELS UH-1D and UH-1H  
 CHART DATE: APRIL 20, 1964

### CARGO TIE-DOWN FITTING DATA



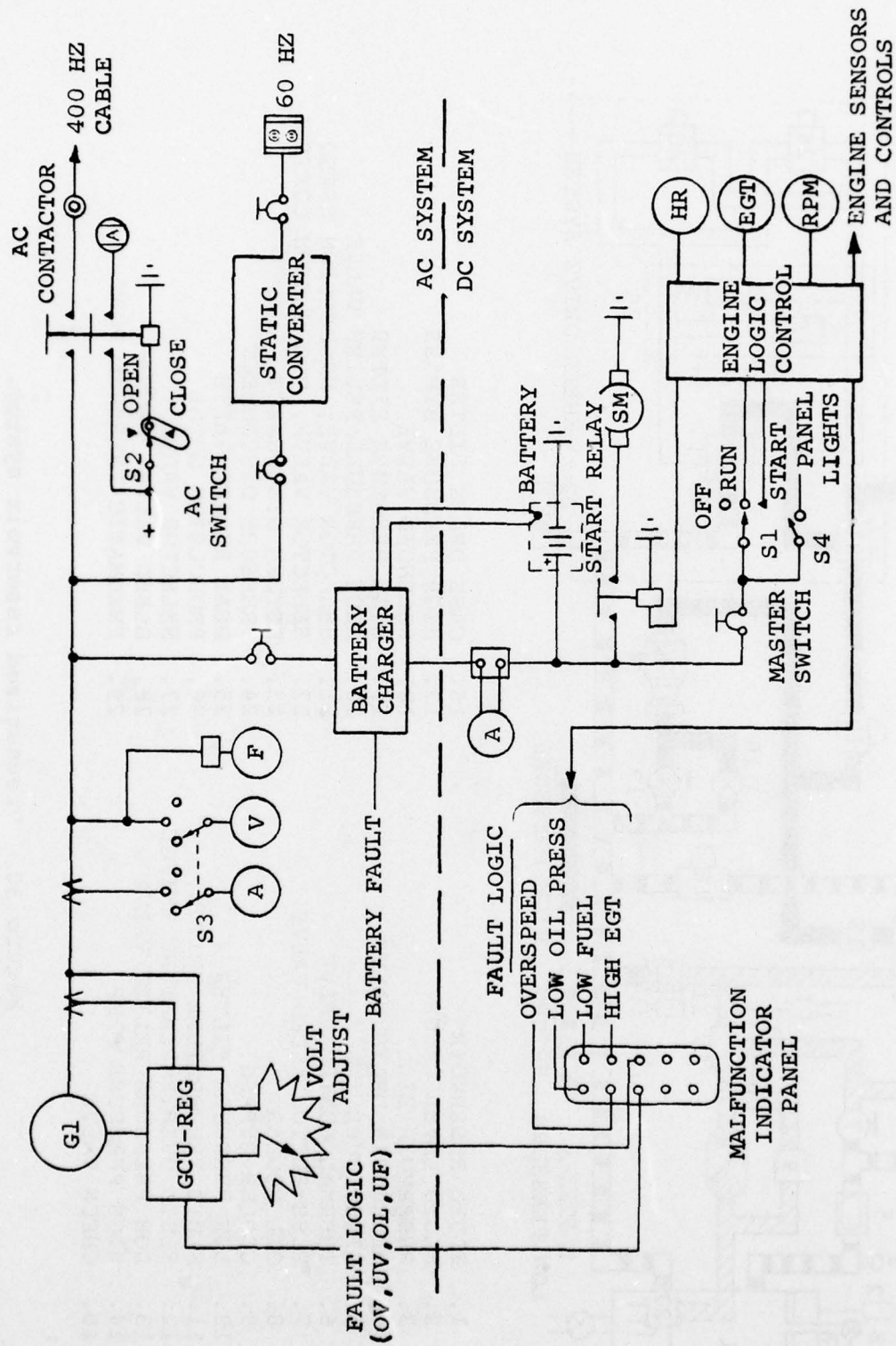
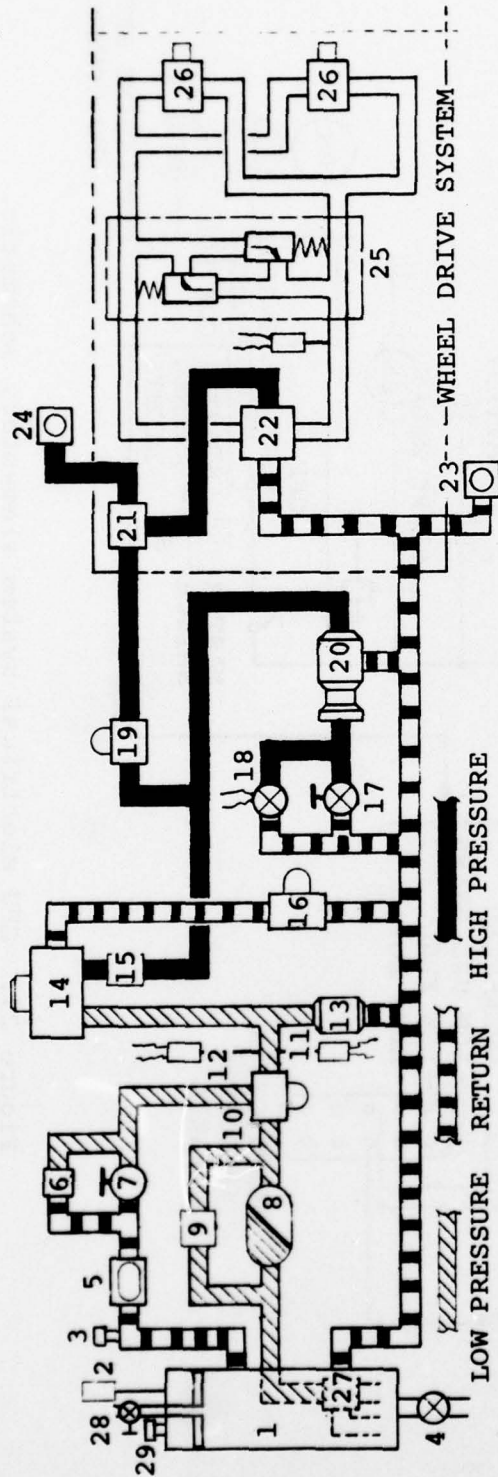

Figure 29. GPU electrical system elementary schematic.



- |     |                              |     |                                    |
|-----|------------------------------|-----|------------------------------------|
| 1.  | FLUID RESERVOIR              | 16. | CASE DRAIN FILTER                  |
| 2.  | FLUID LEVEL GAUGE            | 17. | HIGH PRESSURE BYPASS               |
| 3.  | RESERVOIR FILL               | 18. | SOLENOID VALVE                     |
| 4.  | RESERVOIR DRAIN VALVE        | 19. | HIGH PRESSURE FILTER               |
| 5.  | SIGHT TUBE                   | 20. | HIGH PRESSURE RELIEF VALVE         |
| 6.  | THERMAL RELIEF VALVE         | 21. | SELECTOR VALVE, PROPULSION SPEED   |
| 7.  | PUSH-BUTTON BLEED VALVE      | 22. | SELECTOR VALVE, PROPULSION CONTROL |
| 8.  | OIL COOLER                   | 23. | RETURN DISCONNECT                  |
| 9.  | COOLER BYPASS                | 24. | PRESSURE DISCONNECT                |
| 10. | LOW PRESSURE FILTER          | 25. | DUAL RELIEF VALVE                  |
| 11. | FLUID TEMPERATURE SWITCH     | 26. | PROPULSION MOTOR                   |
| 12. | FLUID OVERTEMPERATURE SWITCH | 27. | SELECTOR VALVE                     |
| 13. | LOW PRESSURE RELIEF VALVE    | 28. | BLEED VALVE                        |
| 14. | HIGH PRESSURE PUMP           | 29. | PNEUMATIC PRESSURE PORT            |
| 15. | CHECK VALVE                  |     |                                    |

Figure 30. Pressurized reservoir system.

The final AAH/UTTAS GPU system recommended by AiResearch is shown in Figure 31. Figure 2 illustrates the GPU size relative to an average person as determined by principles of human engineering.

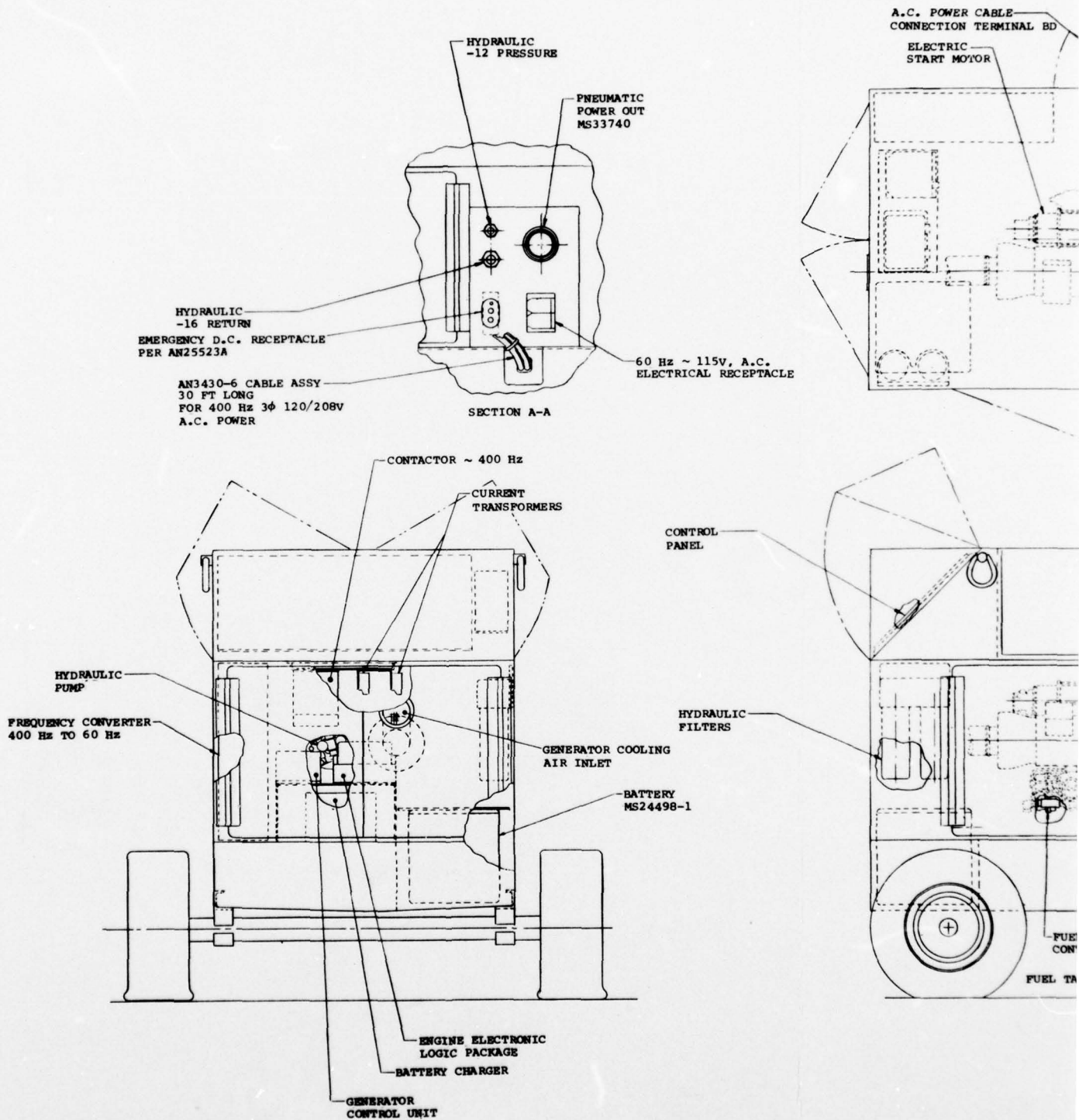
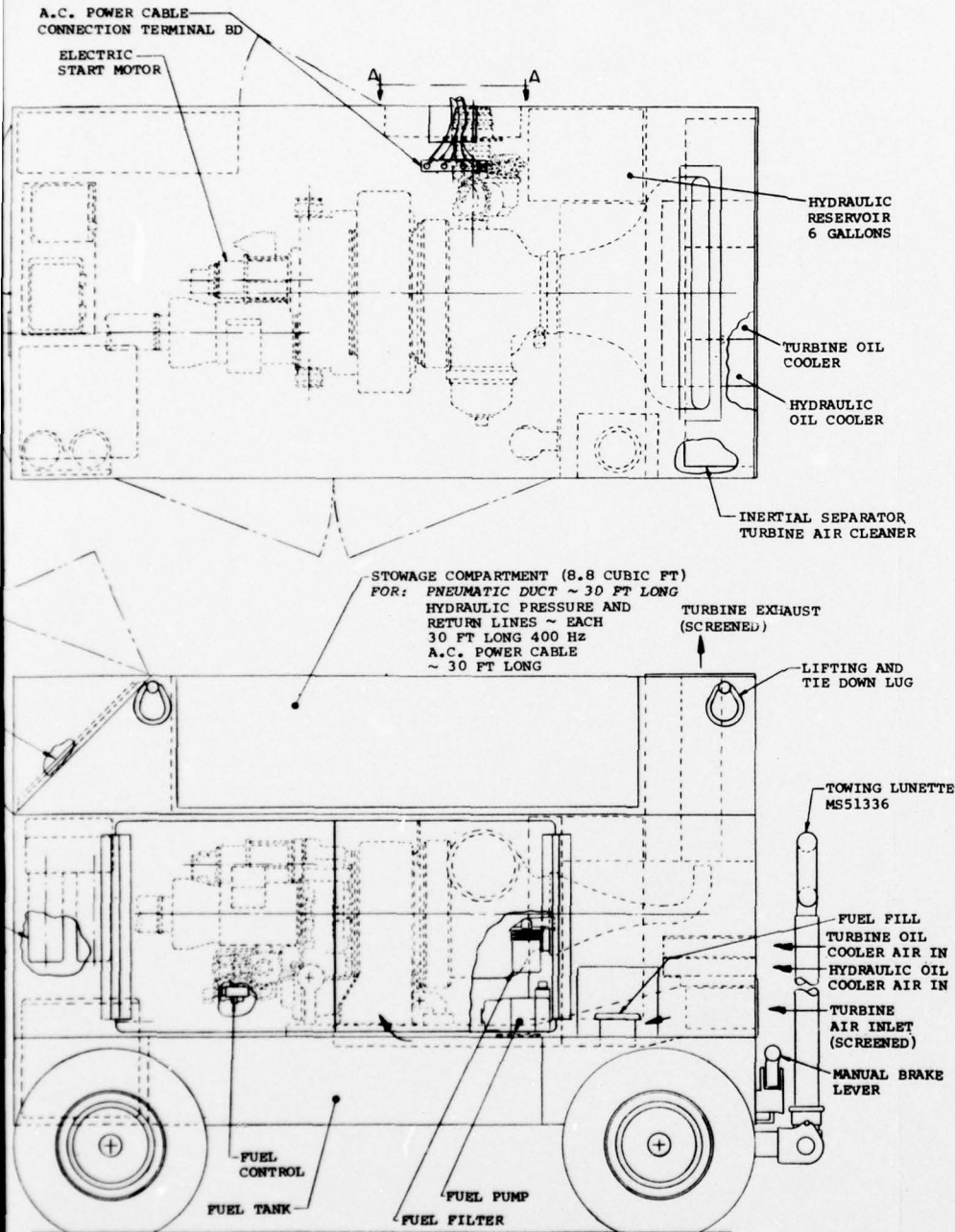

Figure 31. Ground power unit, recommended configuration.



2

#### 4.0 TRADE-OFF FOR CURRENT AIRCRAFT

The GPU presented as a result of detailed trade-off analyses discussed in Section 3.0 was designed specifically to service AAH and UTTAS helicopters. The next program task was to evaluate the needs of existing inventory aircraft. These include the UH-1, AH-1, CH-47, CH-54, OV-1, and U-21, and comprise both rotary and fixed-wing, hydraulic- and electric-started aircraft, and which represent the aircraft most likely to remain in the current Army fleet through the period in which the advanced GPU would be expected to operate. The intent of this task was to review existing support documentation for the aircraft to determine the following:

- o Ground service requirements
- o Interfaces
- o Ground support performance requirements
- o Mobility requirements

It was then necessary to determine what modifications would be required in the selected GPU system to fit with some or all of the existing aircraft and to provide ground service support.

#### 4.1 Review Current Aircraft Requirements

The initial aircraft requirements review activity was to procure appropriate aircraft manuals. These manuals were provided by USAAMRDL for AiResearch use in the Task III effort. Manuals procured were the operation and service manuals and aviation unit maintenance manuals for the following aircraft: AH-1, UH-1, CH-47, CH-53, CH-54, U-21, OV-1. The CH-47D was included in the existing aircraft evaluation. Details of this aircraft, which varied from the B and C models, were acquired both from USAAMRDL and directly from Boeing Vertol. Operation and service manuals were reviewed specifically for information relating to ground service support procedures, and generally included the locations of the ground service connections, and a photographic description of the attach points. Maintenance manuals were reviewed for input requirements that might size the output devices on the ground power unit and for descriptive information concerning the aircraft systems that must be supported. Electrical, hydraulic, and pneumatic systems schematics, and any peculiarities that might affect the GPU, the aircraft, or the interface between the two were reviewed. Manuals also were reviewed to determine any operating limitations affecting gas turbine operation inside the rotor radius. Existing aircraft ground power requirements defined by the aircraft manual review are summarized in Table 22.

TABLE 22. EXISTING AIRCRAFT GROUND POWER REQUIREMENTS

	UH-1 D/H	AH-1 G/Q	CH-47 B/C	CH-47 D	OV-1 B/C	U-21 A/D	CH-54 A/B
	N/R	N/R	N/R	N/R	N/R	N/R	N/R
Pneumatic							
Electric	28 vdc 300A	28 vdc 200A T-R 1000A O'load	28 vdc 200A T-R	28 vdc 200A T-R	28 vdc 500A	28 vdc 200A	28 vdc 200A T-R
	200A St-gen 300A (Later models)	20 kva-115V 400 Hz 3 $\phi$ gen	20 kva-115V 400 Hz 3 $\phi$ gen	2500 va and 115V 400 Hz 3 $\phi$ gen	2500 va and 750 va inv 400A St-gen	2500 va inv 115V 400 Hz 3 $\phi$ gen 1 $\phi$ 250-300A	10 kva-115V 400 Hz 3 $\phi$ gen
	300A Gen					St-gen 34A-hr NiCad	
	34A-hr NiCad	11A-hr NiCad		22 A-hr NiCad		22A-hr NiCad	
	Elec Start 650A	650A		Elec Start 500A		Elec Start 650A	
Hydraulic	6 gpm 1000 psi	14.2 gpm 3000 psi-F.C. 11 gpm 3000 psi-Util 22.5 gpm-agb 4000 psi	8 gpm 3000 psi F.C. 15 gpm 3000 psi-Util	6 gpm 3000 psi		N/R	12 gpm (Hoists) 3500 psi (Eng. St) 6 gpm (1st Servo) 3000 psi 6 gpm 2000 psi 6 gpm (Utility) 1500 psi
	Ambient Res	Hydraulic Start Ambient and Press. Res.	Hydraulic Start Press. Res.	Press. Res.			Hydraulic Start Vented Res.

#### 4.1.1 UH-1

The UH-1 review indicated that the aircraft has a 200-300 amp, 28-vdc electric starter-generator, which also doubles as a standby generator. The operation and service manual states that 650 amps dc is required to start the main engine at reduced ambient temperatures. The aircraft electrical system incorporates a 34-amp/hr NiCad battery, a 300-amp, 28-vdc main generator, and a 400-Hz, 115-volt inverter. The aircraft also incorporates a small hydraulic system to operate flight controls. This hydraulic system uses an ambient-vented reservoir and provides a system flow rate of 6 gpm at 1000 psi. The aircraft has no pneumatic system.

#### 4.1.2 AH-1

The AH-1 engine is electrically started. The aircraft contains either a 22- or a 34-amp/hr NiCad battery and requires up to 650 amps power for main engine starting. The electrical system consists of the 300-amp, 28-vdc starter-generator and a static inverter for 115-volt, 400-Hz output. The unit also contains an ambient-vented hydraulic reservoir. System flow is 6 gpm at 1500 psi. No pneumatic system is provided.

#### 4.1.3 CH-47B/C

The CH-47 is a more complicated aircraft than either the UH-1 or AH-1. It has both 115-v 400-Hz and 28-vdc electrical systems. Primary aircraft power is 115 vac, 400 Hz. The main engines are hydraulically started; therefore the electrical storage capacity on board the aircraft is small. The CH-47 uses an 11-amp/hr NiCad battery for control and instrumentation requirements. DC power on board the aircraft is provided by a 200-amp TR unit. AC power is provided by a 20-KVA, 115-volt, 400-Hz, three-phase, gearbox-driven alternator. Both ac and dc external power receptacles are provided, but an ac input would energize both aircraft systems through the TR unit. There are three hydraulic systems on board the aircraft. Two identical flight control systems provide flight control redundancy for better survivability in case of battle damage. The third system is the aircraft utility system used for aircraft braking and power for the hydraulic hoisting systems. The CH-47 has an on board APU that is started by a hydraulic pump/motor assembly. The APU hydraulic pump output is used to provide main engine starting power. System capacities are 14.2 gpm at 3000 psi for flight control, 11 gpm at 3000 psi for the utility systems, and 22.5 gpm at 4000 psi for main engine start from the APU. Pneumatic system input is not required.

#### 4.1.4 CH-47D

The CH-47D is an updated modernized version of the basic B and C models. Major changes have been made in the aircraft hydraulic system. The electrical systems were basically unchanged from the B and C models. Hydraulic system modifications reduced flight control system flows from 14 to 8 gpm. System pressure of 3000 psi was maintained. Modular hydraulic system components (pumps) are used. The utility system has been increased to 15 gpm and 3000 psi. Main engine start capability is still provided by the on board APU. However, pressure and flow have been reduced to 16.5 gpm at 3350 psi for engine starts. The hydraulic system reservoir is pressurized at 60 psi. The 3350 psi main engine start requirement was established only to meet a -40° start requirement using MIL-H-83282 hydraulic fluid. Under normal ambient conditions, and/or using MIL-H-5606 hydraulic fluid, all aircraft system functions could be accomplished using a system pressure of 3000 psi. Pneumatic ground power input is not required.

#### 4.1.5 OV-1

The OV-1 is primarily a dc electrical system aircraft, although some ac is provided. However, engine start and most normal aircraft system operation is provided by 400-amp starter-generators driven by the main engines. Starting from a ground power supply is not allowed by the technical manuals. The aircraft storage battery is a 22-amp/hr NiCad, which provides starting power. A small pressurized reservoir hydraulic system is also provided. This system is rated at 6 gpm at 3000 psi. No GPU pneumatic or electrical input is required.

#### 4.1.6 U-21

The U-21 is an electrically started, dc aircraft. One version, the RU-21D, requires a small quantity of 115-volt, 400-Hz, single-phase ac for electronic countermeasure equipment on board the aircraft. Primary power utilization and generation on the aircraft is 28 vdc provided by a 250- to 300-amp starter-generator on each main engine. The storage battery is a 34-amp/hr NiCad. The main engines are electrically started, requiring 650 amps dc maximum. There are no pneumatic or hydraulic systems on board the aircraft. A ground service connection is provided on the RU-21D for the single-phase ac requirement. That power is provided on the aircraft by a small inverter.

#### 4.1.7 CH-54

The CH-54 is a complicated aircraft having both 28-vdc and 400-Hz ac electrical systems and four hydraulic systems. The primary electrical system on board the aircraft is provided by a gearbox-driven 10-kva, 115-volt, 400-Hz, three-phase alternator. Onboard dc is provided by a 28-volt, 200-amp TR unit. A 22-amp/hr NiCad storage battery is also provided. One aircraft hydraulic system is used to drive the cargo hoists and for main engine starts. There are also two flight control hydraulic systems and a utility system. The hoisting and engine start system is rated at 12 gpm, 3500 psi. The first servo (flight control system) is a 6-gpm, 3000-psi system, and the second a 6-gpm, 2000-psi system. The aircraft utility system is rated 6 gpm, 1500 psi. Main engines are hydraulically started. The aircraft reservoir is vented to ambient. No pneumatic system input is required.

#### 4.2 GPU System Modifications

GPU changes required to support existing aircraft ground power requirements are summarized in Table 23. This data indicates that the GPU requires no pneumatic system modifications to fit all existing aircraft considered in this study. A 28-vdc output capability must be incorporated to provide dc electric start requirements for the UH-1, AH-1, and U-21, and ground maintenance requirements for the OV-1. A 200-amp system with overload capability to 1000 amps would be required for low temperature engine starts. A GPU hydraulic system modification must be incorporated to accommodate variations in existing aircraft hydraulic systems. Variations include use of both ambient-vented and pressurized reservoir systems and variable system output pressures from 1000 to 4000 psi.

##### 4.2.1 Electric System

The 20-KVA, 400-Hz, 115-volt, three-phase, ac generating system proposed for the recommended GPU concept is adequate to supply all existing aircraft ac needs. Existing aircraft dc starting and secondary power supply requirements could be met by incorporating a 200-amp continuous rated, 500-amp intermittent rated TR unit in the existing systems. For aircraft starting requirements, the TR unit output could be paralleled with the 34-amp/hr NiCad battery, allowing intermittent operation at currents up to 1000 amps. The 200-amp dc steady-state requirements could be met by the TR unit steady-state rating. These schemes are shown as Systems 2 and 3 in Figure 12. System No. 3, retaining the "maintenance-free" battery charging scheme was recommended.

TABLE 23. CHANGES TO FIT EXISTING AIRCRAFT

- |           |   |  |
|-----------|---|--|
| Pneumatic | o | None   |
| Hydraulic | o | New Pump with Variable Pressure Compensator Adjustment                 |
|           | o | Attachments to Adapt to Various Line Sizes                             |
|           | o | Boost Pump to Allow Operation From Vented or Pressurized Reservoir     |
| Electric  | o | Bigger Transformer Rectifier Unit(s) to Allow up to 1000 AMP DC Output |
|           | o | DC Output Cables   |

#### 4.2.2 Hydraulic System Modifications

Variations in existing aircraft hydraulic systems are related to the reservoirs and system pressure and flow. The reservoirs are both vented to ambient and pressurized to levels from 11 to 60 psig. To allow GPU operation with the variable systems will require a more sophisticated GPU reservoir. The reservoir would include a selector valve to allow operation either on the aircraft reservoir or the GPU reservoir. In addition, to allow operation with reservoir pressures varying from ambient to 60 psi, a boost pump would be required that would maintain a minimum 35-psig inlet pressure to the GPU hydraulic pump to prevent cavitation. The GPU hydraulic pump selected is a variable displacement pump, to match with any of the existing aircraft systems' flow requirements. To fit with the different output system pressures, however, an adjustable and variable pressure compensation device would be required. The presently selected Vickers PV-3-075 hydraulic pump does not have variable pressure compensation capability; therefore, a different GPU pump would be required to meet system demands.

#### 4.3 Recommended Concept

The recommended multi-application GPU concept is shown in Figure 32. Envelope dimensions are unchanged from the system described for AAH and UTTAS only. Required modifications described in Para. 4.2 are all internal to the GPU system enclosure. The 200-amp TR unit is located adjacent to the gas turbine power plant, immediately aft of the power output panel. The hydraulic system boost pump is located adjacent to the hydraulic system reservoir. The dc output cable is connected inside the GPU enclosure and fits in the service conductor storage contained at the top of the unit. System weight increased by 93.7 pounds. The electrical system recommended for the multi-application GPU is System 3, Figure 33. The recommended multi-application GPU hydraulic system is shown in Figure 34.

#### 4.4 Program Review

A program review and concept selection meeting was held at AiResearch on February 2 and 3, 1977 to review, with interested Army agencies, the recommended GPU concepts for AAH and UTTAS and for application to existing aircraft. The agencies represented in the design review meeting were as follows:

- (a) USAAMRDL, Fort Eustis, Virginia
- (b) AAH-PMO, St. Louis, Missouri

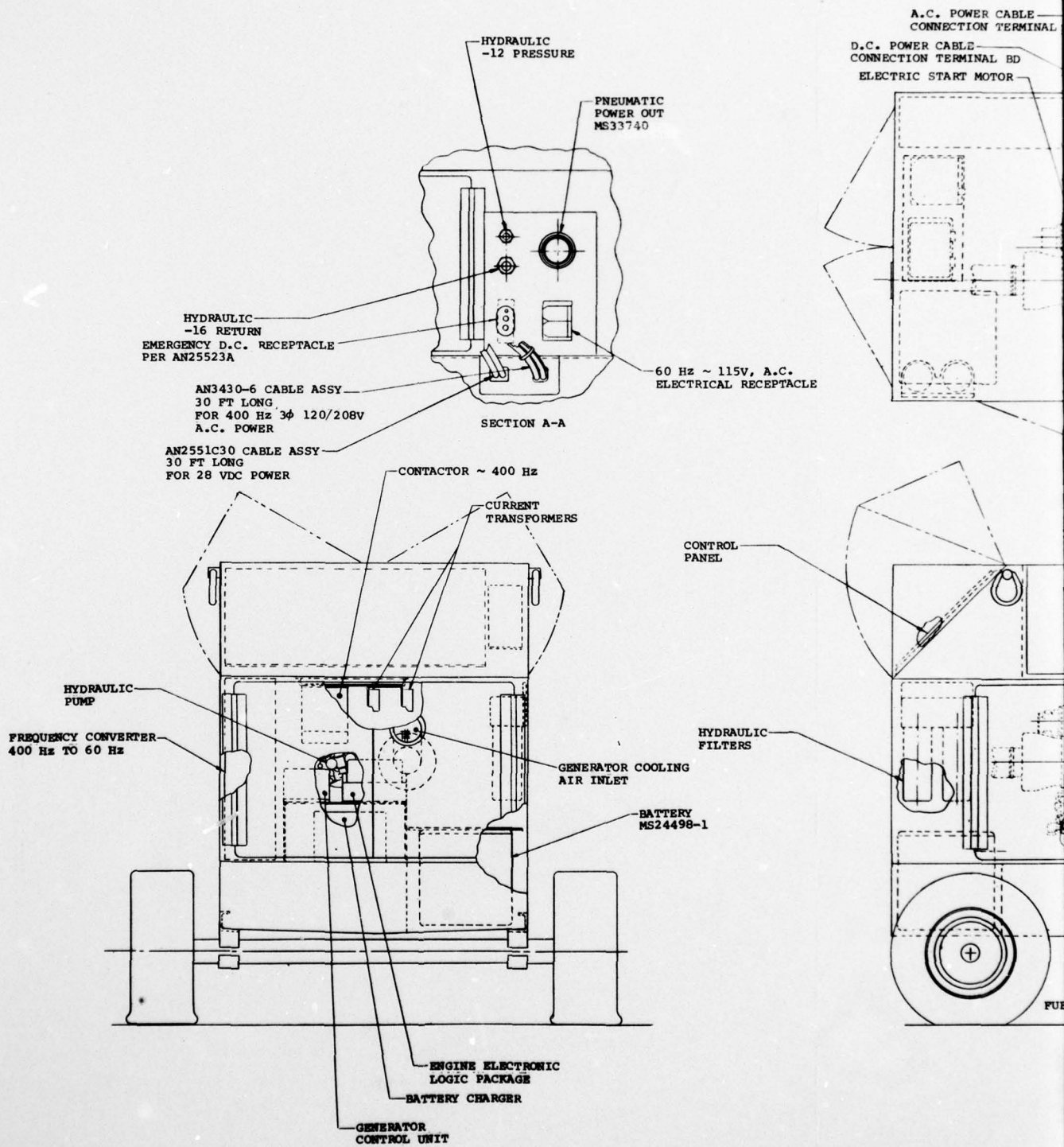
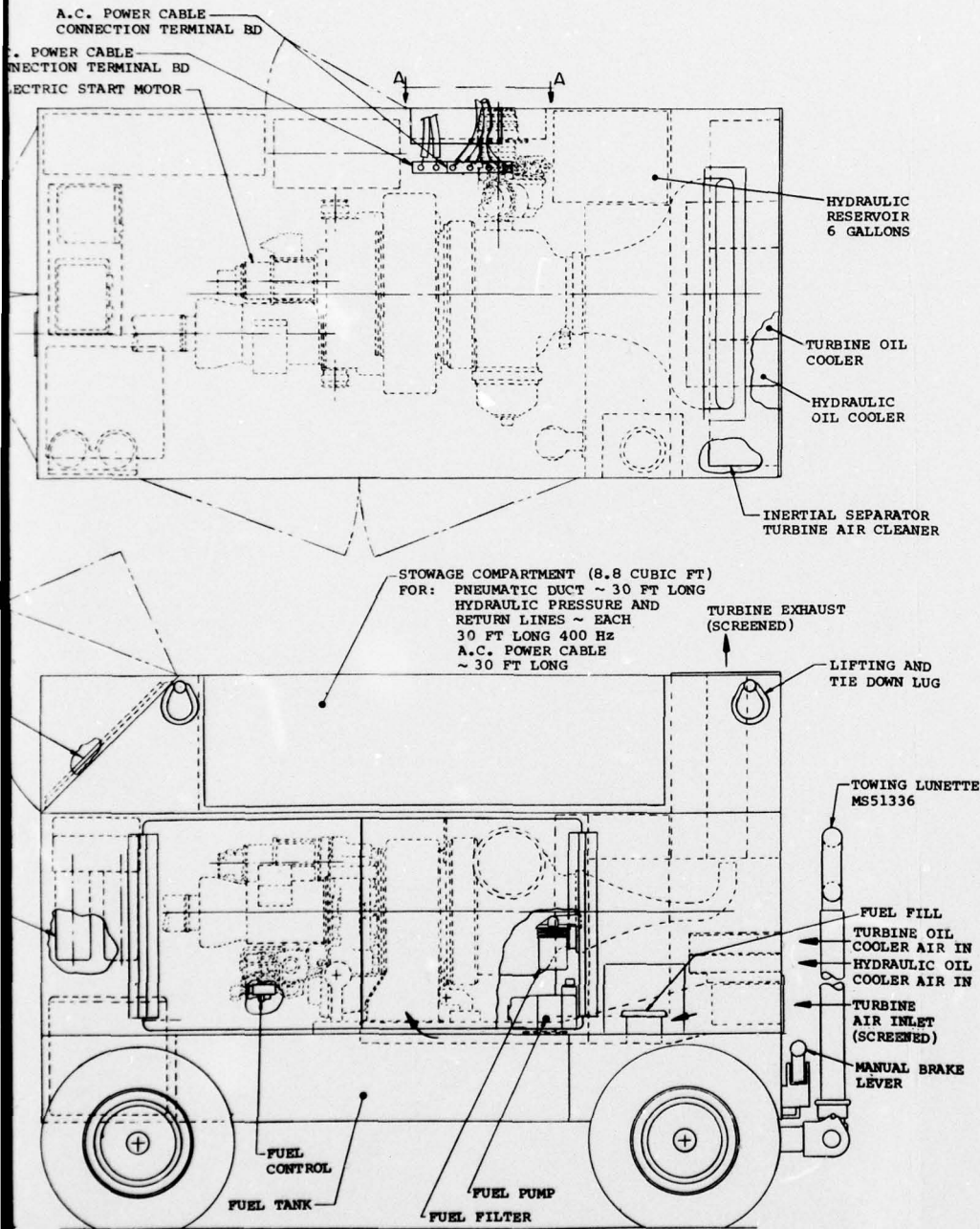
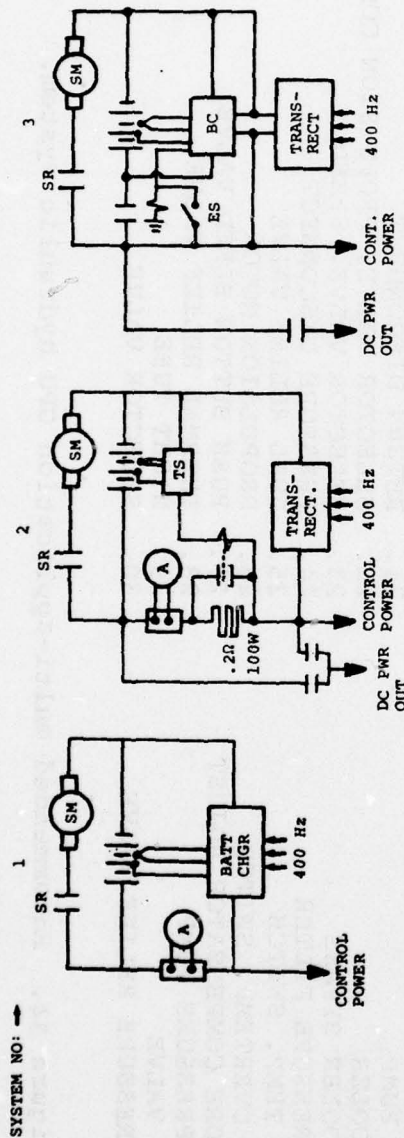

Figure 32. Ground power unit, DC output for current fleet aircraft.



craft.



APPLICABLE TO: →	AAH AND UTTAS	ALL HELICOPTERS	ALL HELICOPTERS
WEIGHT			
AM + SHUNT CHARGER	4.9	4.9	7
TRANS-RECT RELAYS/CONTACTORS/NOISE	20	17	17
	24.9 (TOT)	32.1 (TOT)	31 (TOT)
VOLUME			
AM + SHUNT CHARGER	25	25	280
TRANS-RECT RELAYS/CONTACTORS/NOISE	373	410	410
	398 (TOT)	206	820 (TOT)
COST			
AM + SHUNT CHARGER	26	26	900
TRANS-RECT RELAYS/CONTACTORS/NOISE	900	1300	1300
	926 (TOT)	750	2575 (TOT)
RELIABILITY	GOOD	AVERAGE	EXCELLENT
MAINT. (\$/YR)	AVERAGE	HIGH	MINIMAL

Figure 33. Alternate GPU electrical systems.

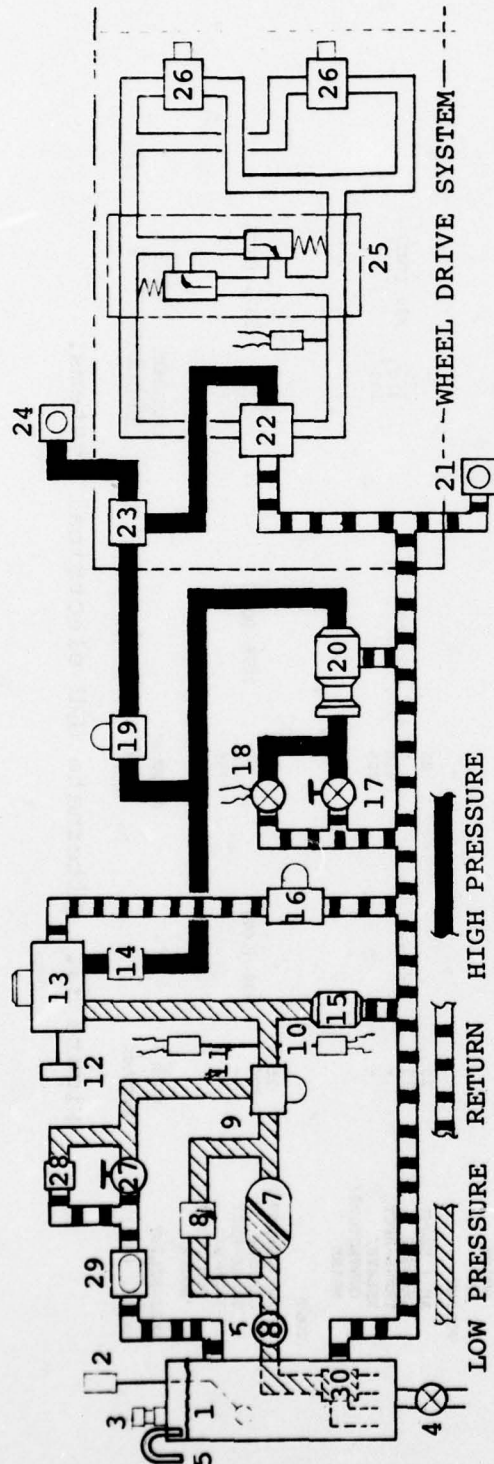

- |     |                             |     |                                    |
|-----|-----------------------------|-----|------------------------------------|
| 1.  | FLUID RESERVOIR             | 16. | PUMP CASE FILTER                   |
| 2.  | FLUID LEVEL RESERVOIR GAUGE | 17. | HIGH PRESSURE BYPASS               |
| 3.  | RESERVOIR FILL              | 18. | SOLENOID VALVE                     |
| 4.  | RESERVOIR DRAIN VALVE       | 19. | HIGH PRESSURE FILTER               |
| 5.  | RESERVOIR VENT (AMBIENT)    | 20. | HIGH PRESSURE RELIEF VALVE         |
| 6.  | BOOST PUMP                  | 21. | RETURN DISCONNECT                  |
| 7.  | OIL COOLER                  | 22. | SELECTOR VALVE, PROPULSION CONTROL |
| 8.  | OIL COOLER BYPASS           | 23. | SELECTOR VALVE, SPEED              |
| 9.  | LOW PRESSURE FILTER         | 24. | PRESSURE DISCONNECT                |
| 10. | FLUID TEMP. SWITCH          | 25. | DUAL RELIEF VALVE                  |
| 11. | FLUID OVERTEMP. SWITCH      | 26. | PROPULSION MOTOR                   |
| 12. | PRESSURE COMPENSATOR ADJUST | 27. | PUSH BUTTON BLEED VALVE            |
| 13. | HIGH PRESSURE PUMP          | 28. | THERMAL RELIEF VALVE               |
| 14. | CHECK VALVE                 | 29. | SIGHT TUBE                         |
| 15. | LOW PRESSURE RELIEF VALVE   | 30. | SELECTOR VALVE                     |

Figure 34. Recommended multi-application GPU hydraulic system.

- (c) AVSCOM, R&D Directorate, St. Louis, Missouri
- (d) TRADOC (USATSCH), Fort Eustis, Virginia
- (e) PM-MEP, Springfield, Virginia

These represented both development and user agencies anticipated to be involved in development and application of the production model of the U.S. Army advanced GPU. During this meeting, the program evolution described by the various charts and descriptions contained in the concept formulation and concept selection sections of this report were presented. This presentation led to definition of the GPU for AAH and UTTAS, and the multi-application unit to service other aircraft. As a result of the presentations and discussions during the meeting, a final concept to service AAH, UTTAS, and CH-47D was defined.

This unit would embody the following characteristics:

- (a) Gas turbine power plant with integral two-pad gearbox and integral bleed capability. The system was designed around the AiResearch Model GTCP36-50D APU.
- (b) 15 gpm, 3000 psig, variable displacement, pressure compensated hydraulic pump - Vickers PV3-075.
- (c) 20 kva, 12,000 rpm, air-cooled alternator - Bendix Model 28B262-27.
- (d) Fiberglass enclosure - Based on design provided by Brunswick Corporation.
- (e) Self-propelled, wheeled system.

Subsequent to the meeting, authority was received from the contracting officer to proceed with design optimization, design layout, and specification description of the unit ultimately defined during the concept program review meeting.

During the concept selection meeting, it was decided that there is sufficient equipment in the Army inventory to perform the starting function for aircraft equipped with dc start systems. Therefore, the need for the TR disappeared and System #1 (Figure 33) became the selected scheme.

The need for a 60-Hz power supply was reassessed during the concept selection meeting. Cost, weight, and volume

penalties imposed on the GPU were still considered too great for the questionable benefit, and the requirement for a 60-Hz signal output was deleted. As a compromise, it was agreed to provide a 400-Hz, 115-volt convenience outlet on the GPU, which would have a decal warning that it was 400 Hz. A conventional, parallel-blade (with grounding pin) receptacle would be provided for equipment such as light kits, soldering irons, and other non-frequency-sensitive devices.

## 5.0 DESIGN OPTIMIZATION

Program concept formulation and selection activities were conducted with the goal of establishing an objective evaluation system and selecting approaches to satisfy design requirements of an advanced GPU. The analyses conducted to establish the concepts on which the recommended arrangements were based were performed in adequate depth to ensure feasibility, but not necessarily to ensure design compatibility. The purpose of the design optimization was to continue component evaluation to the point of assuring compatibility, specify additional hardware critical to GPU function, and complete the definition of hardware unique to the GPU.

### 5.1 Specification of Equipment

Prior to submitting the advanced GPU design layout, an attempt was made to ensure compatibility of the equipment selected and specified as a result of the trade-off studies. In certain cases, it was found that components or subsystems were not compatible, either with the other components in the subsystem or with the other subsystems in the GPU system. For this reason, a certain amount of redesign, reevaluation, and redefinition of various GPU system parts was required.

#### 5.1.1 Wheel Drive

The recommended GPU concept did not consider a self-propelled device, although self propulsion had been considered subsequent to meetings with the airframe manufacturers. The towed vehicle system, as pointed out during the concept selection task discussion, met all problem statement requirements. As a result of the concept review meeting discussion of vehicle mobility, the self-propelled feature was reinstated as a part of the advanced GPU.

Wheel-drive mechanisms considered to that point included the pneumatic drive recommended by Vehicle Systems in the original design approaches, and a hydraulic drive originally considered during the concept formulation and concept selection tasks. No further investigation or analysis was done once it was decided that a towed vehicle met problem statement requirements. When the self-propelled feature was reinstated, it became necessary to review information that had been accumulated to that point.

As discussed in Para. 3.2.7, live axle designs using a single drive motor and differential, live axle designs using a simple offset gearbox, and direct-drive hydraulic motors,

were evaluated before selecting a towed device for the recommended concept. Further evaluation of concepts considered revealed problems with each of the devices.

The live axle design with offset gearbox provided a relatively low cost arrangement, allowing the use of a single-drive motor. However, major modifications to the skidbase/tank assembly would be required to provide space for the offset gearbox. In addition, no differential action would be provided for the driving wheels, requiring skidding of the outside wheel during turns. The live axle differential arrangement overcame the problem of wheel skidding. However, this system required even more space than the offset gearbox system, and again would have required a major redesign of the fuel tank.

A review of available data indicated that gerotor hydraulic motors, provided by Char-Lynn Division of Eaton Manufacturing Company, would provide adequate torque for use in a direct-drive application into the wheel axle without requiring the use of a gearbox or solid axle, thereby significantly reducing packaging impact, weight, and cost. A design calculation for the Char-Lynn motor was completed to provide sizing for motor drives. For the 7.4-in. rolling radius of the Goodyear 16 x 6.5-8, Soft Trac Terra Tire, a maximum 68 motor rpm would be required for the 3-mph maximum vehicle speed. Maximum vehicle towing resistance was determined to be 495 lb. This compared very favorably with the estimated 490 lb maximum provided by Vehicle Systems for the towed device. The total tractive effort for the vehicle, which includes acceleration torque, was determined to be 546 lb. This required 4040 in.-lb total hydraulic motor torque or 2020 in.-lb each for the two motors anticipated for this application. This torque can be delivered through the wheels with tire inflation pressure reduced to approximately 15 psig. The Char-Lynn motor selected was of the "S" series with a mid-mounted flange having 23 cubic in. per revolution displacement. The motor could actually deliver torque in excess of that required. However, the slight oversizing involved was felt to enhance starting capabilities.

#### 5.1.2 Hydraulic System

The hydraulic system defined in Figure 35 was derived to fit aircraft systems using pressurized reservoirs; the maximum reservoir pressure anticipated was 60 psi as used on the CH-47D. It was intended that matching reservoir pressure would be provided in the GPU either by pressurization through bleed-air from the GPU power plant or by a separate gas bottle pressurization arrangement similar to that used on the helicopters. The system would be adjustable so that aircraft

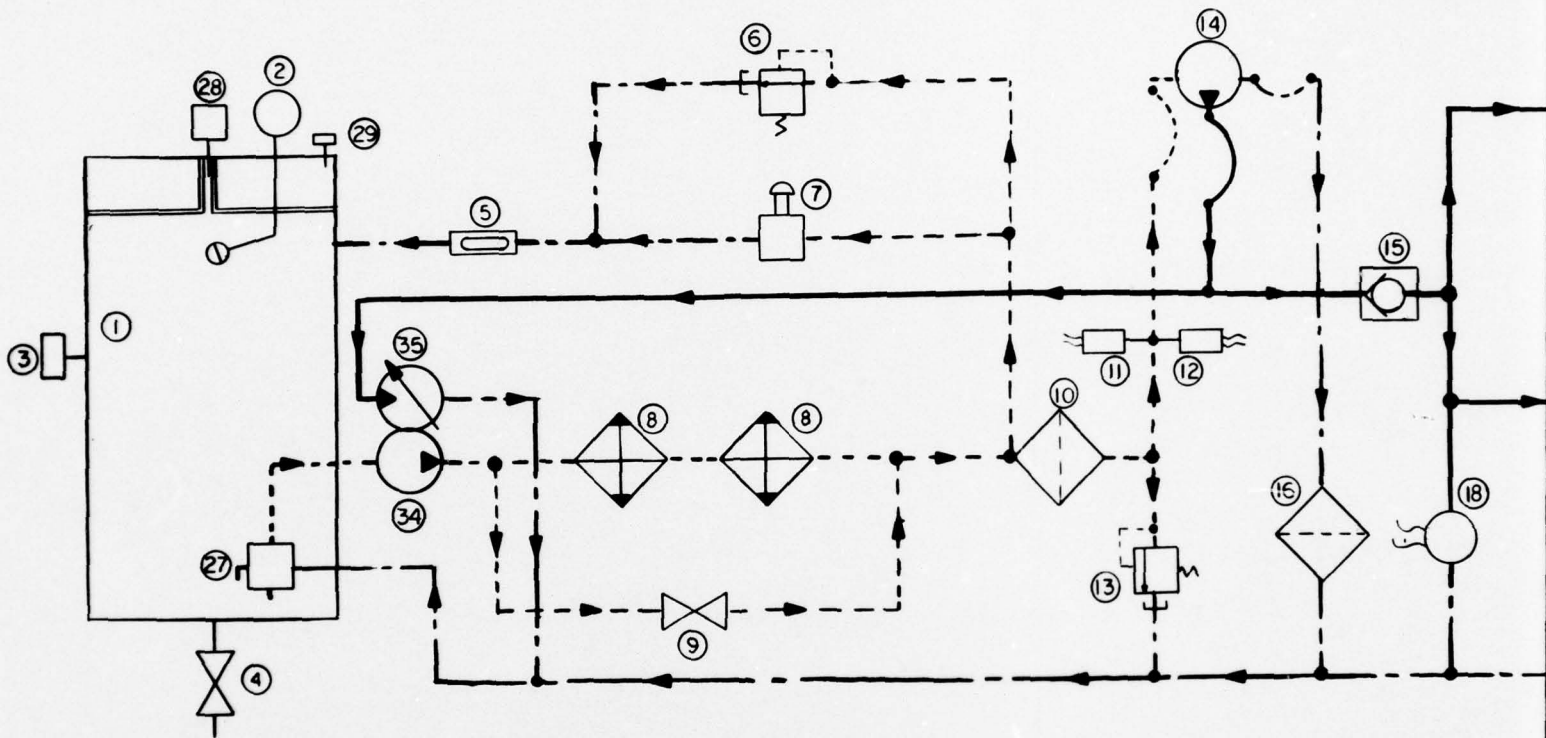

- |                            |                                      |                            |
|----------------------------|--------------------------------------|----------------------------|
| ① FLUID RESERVOIR          | ⑫ FLUID OVERTEMPERATURE SWITCH       | ⑳ RETURN DISCONNECT        |
| ② FLUID LEVEL GAUGE        | ⑬ LOW PRESSURE RELIEF VALVE          | ㉑ PRESSURE DISCONNECT      |
| ③ RESERVOIR FILL           | ⑭ HIGH PRESSURE PUMP                 | ㉒ DUAL RELIEF VALVE        |
| ④ RESERVOIR DRAIN VALVE    | ⑮ CHECK VALVE                        | ㉓ PROPULSION MOTOR         |
| ⑤ SIGHT TUBE               | ⑯ CASE DRAIN FILTER                  | ㉔ SELECTOR VALVE           |
| ⑥ THERMAL RELIEF VALVE     | ⑰ HIGH PRESSURE BYPASS-MANUAL        | ㉕ BLEED VALVE              |
| ⑦ PUSH BUTTON BLEED VALVE  | ⑱ HIGH PRESSURE FILTER               | ㉖ PNEUMATIC PRESSURE GAUGE |
| ⑧ OIL COOLERS              | ㉒ HIGH PRESSURE RELIEF VALVE         | ㉗ DRIVE SYSTEM FILTER      |
| ⑨ COOLER BYPASS            | ㉓ SELECTOR VALVE, PROPULSION SPEED   | ㉘ PRESSURE GAUGE           |
| ⑩ LOW PRESSURE FILTER      | ㉔ SELECTOR VALVE, PROPULSION CONTROL | ㉙ WARNING HORN             |
| ⑪ FLUID TEMPERATURE SWITCH |                                      | ㉚ WHEEL DRIVE SOLENOID     |

Figure 35. Selected ground power unit, hydraulic schematic.

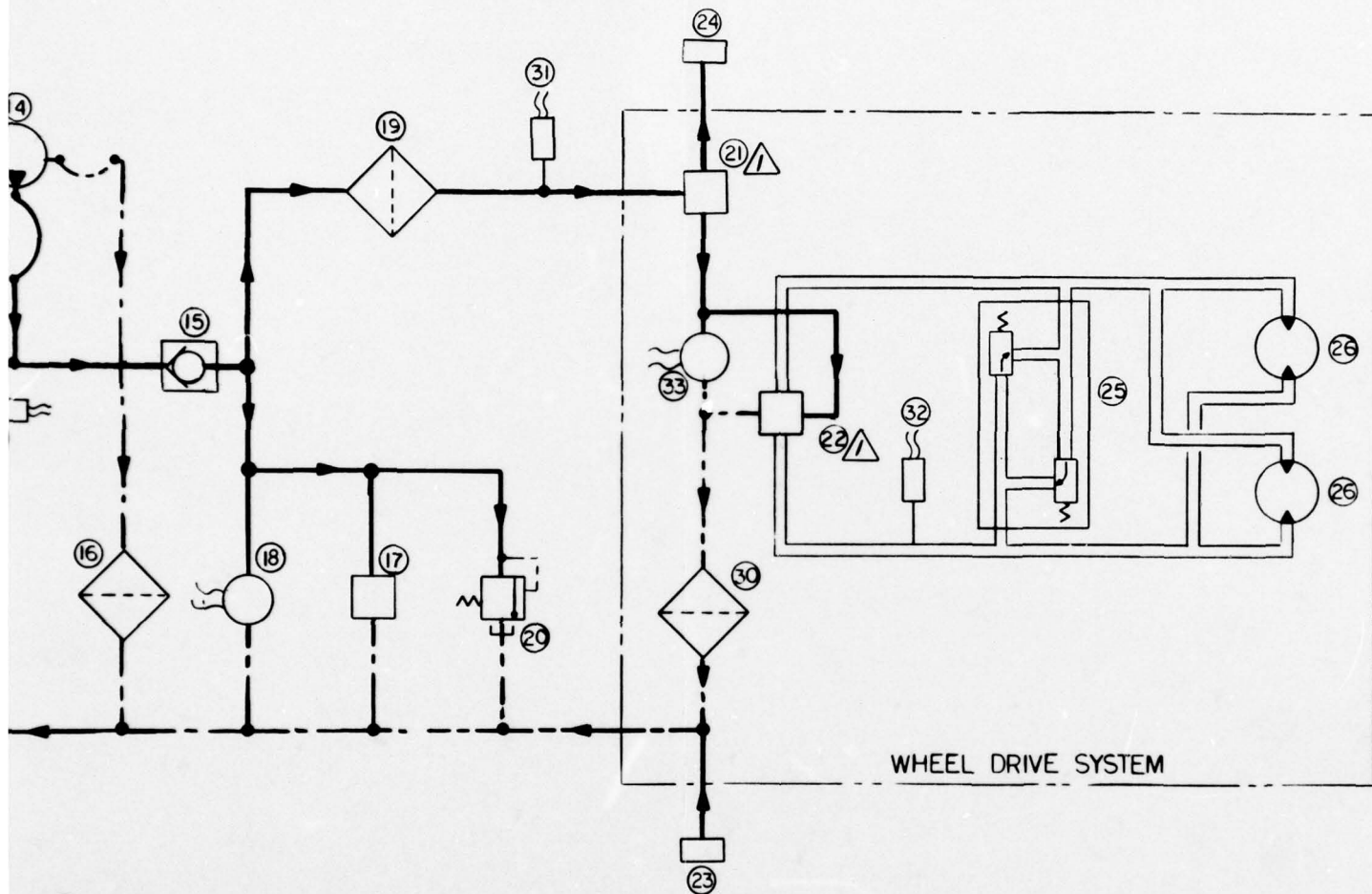

- ②③ RETURN DISCONNECT
- ②④ PRESSURE DISCONNECT
- ②⑤ DUAL RELIEF VALVE
- ②⑥ PROPULSION MOTORS
- ②⑦ SELECTOR VALVE
- ②⑧ BLEED VALVE
- ②⑨ PNEUMATIC PRESSURE PORT
- ③⑩ DRIVE SYSTEM FILTER
- ③① PRESSURE GAUGE TRANSDUCER
- ③② WARNING HORN INTERLOCK SWITCH
- ③③ WHEEL DRIVE SAFETY BYPASS VALVE

———→ HIGH PRESSURE  
 - - - - -→ RETURN  
 ······→ LOW PRESSURE

⚠ THE FUNCTIONS OF VALVES ②① & ②② MAY BE COMBINED INTO A SINGLE VALVE.

system pressure could be matched by GPU system pressure, thus precluding any transfer of fluid from one reservoir to the other. In this manner, the GPU main pump precharge requirement would also be satisfied.

As described in the concept formulation section, one airframe manufacturer chose to consider all UTTAS aircraft data requested by AiResearch as proprietary. As a result, concept formulation and concept selection activities were conducted without any direct information input from that company. Some scattered detail information was obtained, but no hard information was available. Indications were that the reservoir pressure was only 11 psi. This pressure is too low to allow cavitation-free operation of the GPU main pump. Therefore, to provide long life and satisfactory operation in any application, it was necessary to incorporate a boost pump as proposed for the current fleet aircraft systems.

In searching for small, lightweight, compact boost pump systems, a Vickers pump was found that would provide a nearly ideal solution to the boost pump problem. This boost pump design consists of a two-stage pumping section coupled to a hydraulic motor. The two-stage pumping unit is comprised of a centrifugal impeller and vane pump. A fixed displacement, bent-axis motor drives the two pumping units. When high pressure from the main hydraulic system is applied to the motor, it drives the boost pump to deliver inlet flow at a pressure proportional to the high pressure flow.

The boost pump mounts on the reservoir. The inlet in the center of the mounting flange opens directly into the reservoir selector valve. The centrifugal impeller takes fluid from the reservoir to supply the vane pump. The pump then pressurizes the inlet lines to the engine-driven variable displacement pump.

Flow can vary from 0 gpm at 92 psi to 31.5 gpm at lower pressures, depending upon system needs. The controlled flow occurs because the motor and boost pump are torque balanced. That is, as the pump output pressure approaches 92 psi, the motor stalls. This results because the torque then required to turn the pump equals the motor torque capability. When inlet line pressure drops below 92 psi, the motor begins to operate again, to maintain at least a 75-psi inlet pressure to the engine-driven pump. With this feature no relief valve is needed.

### 5.1.3 Battery Charger

During the concept selection meeting, it was recommended that Christie Electric be contacted regarding battery chargers, since their unit was widely used in the Army for shop nickel-cadmium battery maintenance. It had been rejected earlier because of its requirement for a 60-Hz power input. Additional investigation indicated an interest by Christie in adapting the unit to an aircraft-type package using a 400-Hz input. When the final proposal was received, the 400-Hz version was the same package size as the 60 Hz and weight was in the range of 120 to 130 pounds. This was considered to be too large for GPU application.

During the GPU system optimization phase, the dc voltage level imposed on the battery by the battery charger was analyzed in more detail. The charger was designed to supply the battery only and be independent of the system dc bus. In this way, the battery could be run through the proper recharge cycle without concern for other loads that might be affected by these voltage swings. The battery could be switched to the bus in the event of normal dc supply loss. In the GPU application, there was no "normal" dc supply as differentiated from an emergency or backup supply. The battery and its charger were the only source of dc output; therefore, the battery charger output would be imposed on other dc loads.

Further consideration was then given to using a small, 20- to 30-amp TR unit instead of the battery charger. However, the importance of keeping the GPU battery at peak performance condition was considered to outweigh the lower cost of a TR unit. The battery charger design was modified to extract approximately 5 amperes of unregulated 28 vdc from the charger, independent of the battery charger output. This would be used to supply the GPU control system during normal operation. This also permitted recharging the battery in an optimum manner without compromising it by dc control system needs.

### 5.1.4 Running Gear

Running gear selections recommended by Vehicle Systems were discussed in Para. 3.2.7. Items selected from both the United and Saginaw catalogues were presented. In attempting to illustrate mechanical arrangements using catalogue selections, an incompatibility was found. The catalogue components, as recommended, would not assemble without component interference. Wheels would not fit the hubs, and the hubs and drums would not accept the recommended brake systems. Subsequent review with Vehicle Systems indicated that Saginaw

catalogue data was inconsistent and AiResearch was advised to use only the United Manufacturing Co. data. Using United catalogues, a system was assembled (shown in Figures 39 and 41).

#### 5.1.5 Inlet Filter

An inertial inlet air filter was shown in each of the layout sketches describing the GPU. Sizing for this filter was based on available information derived from other applications. In the design optimization phase, two vendors (the Donaldson Company and Aircraft Porous Media) were contacted to establish firm envelope, weight, and cost data for the inertial inlet air filter. Both APM and Donaldson have basic filter tubes to use in fabricating shapes and forms to fit specific installations. Because of the location selected for the GPU inlet, a very thin filter was desired. Therefore, the smallest available swirl tubes were used to establish the filter envelope. Filter sizing was based on an average engine airflow of 3 lb/sec. The specified maximum filter pressure drop was 3 in. H<sub>2</sub>O. From AiResearch calculations, a device 7.5 in. high, 30.5 in. wide, and 3 in. deep was derived.

One unique feature incorporated in the GPU inlet filter installation is the filter scavenge provision. An inertial inlet air filter normally takes a small supply of compressor bleed air, directs it to a jet nozzle, and mixes it with filter scavenge air in the secondary ejector stage to scavenge the contaminated filter air. The GPU inlet filter is immediately adjacent to the exhaust box. Exhaust box pressure would normally run at 5 in. H<sub>2</sub>O with about 3 lb/sec flow capacity. It was felt that filter scavenge capability could easily be provided by attaching the filter body to the low pressure exhaust box area with simple orifice penetrations, without the complexity and cost of an ejector. Discussions with APM indicated that two penetrations would be required, located at either end of the filter element. Because of the space required for scavenge ducting, the effective filter area length was decreased, requiring a slight increase in vertical height. Final anticipated filter height is about 8.7 in. If deterioration in the inlet duct wall occurred due to radiation from the hot pipe, an insulating blanket could be attached.

#### 5.1.6 Noise Characteristics

A GPU noise level was predicted, based on the bare engine noise characteristics of the AiResearch Model GTCP36-50D and on attenuation anticipated from installation components.

Installation treatments were identical to those provided for the MERDC 30-KW generator set. Anticipated noise levels are shown in Figures 36 and 37. The noise levels at the operators station, a series of points at a 3-ft radius from the geometric center of the operators panel and 5 ft, 8 in. from ground level, are compared with requirements of Category D, MIL-STD-1474. From Figure 36, it may be seen that the estimated noise level of the advanced GPU is less than MIL-STD-1474 requirements. The overall noise level at 25 feet is compared with requirements established for the MERADCOM 30-KW gas turbine engine-driven generator set. These measurements were taken at 25 feet from the geometric center of the set at a microphone location 5 ft, 8 in. from ground level. It can be seen that estimated noise levels for the GPU are less than specification requirements. Attaining established noise levels and those projected for the GPU are felt to be within current state of the art in gas turbine engine acoustic treatments.

## 5.2 Design Layout

Although a fairly complete design layout was prepared for the concept review and selection meeting, additional detail information was derived during the design optimization task and a new layout was felt to be justified. For this reason, Figures 38 through 43 were produced. These figures depict general arrangement, outline dimensions, and detail installation information for the major components anticipated to be used in the advanced GPU. The parts list (Figure 38) contains vendor names and part numbers for major components derived from trade-off studies conducted as a part of the program and represents a workable system based on the analysis conducted. Standard hardware or parts that would not significantly affect system performance were specified by description only, not by part number, and may be chosen from any vendor catalogue. Vendor data for all the detail items listed in the GPU parts list were included as part of the contract data. Detail schematics of the hydraulic system, and ac and dc electrical systems and are shown in Figures 35, 44, and 45.

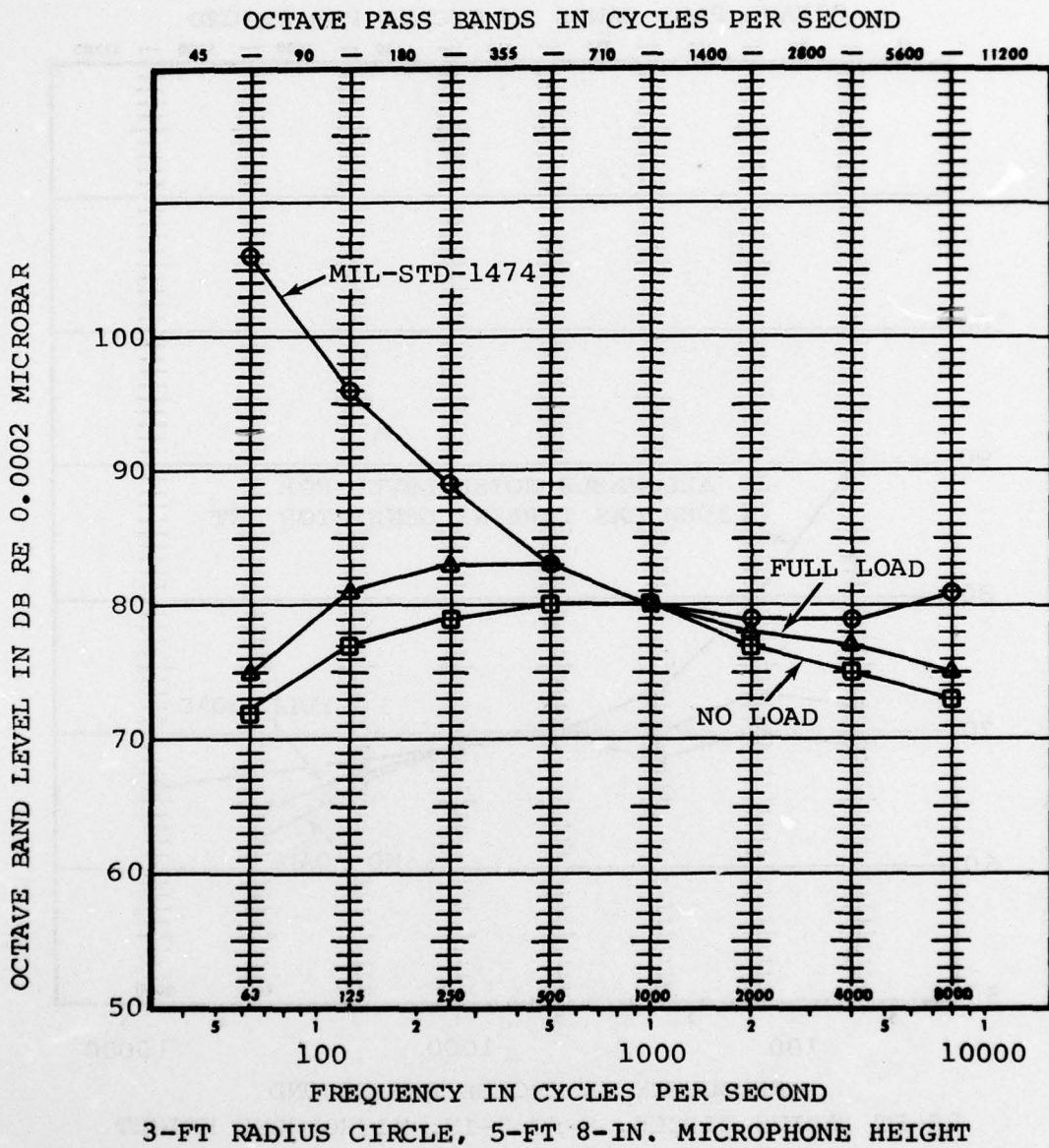

Figure 36. Estimated GPU noise level characteristics.

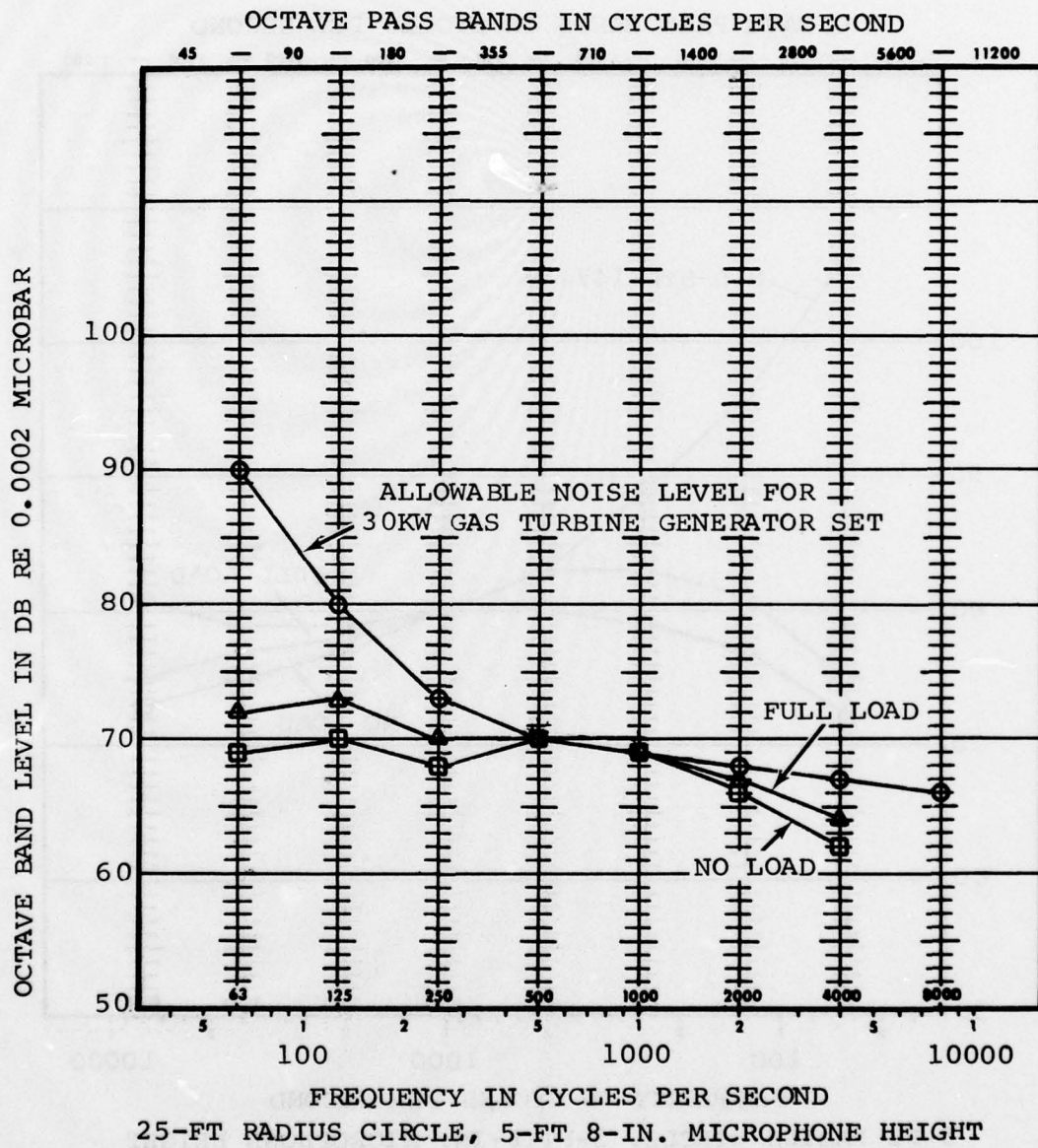

Figure 37. Estimated GPU noise level characteristics.



124	51185		HOSE ASSEMBLY, PNEU (30 FT)	H. K. PORTER
123	7950-82		COUPLING HALF, QUICK DISCONNECT	ROYLYN-KAISER
119	AA-15508		BOOST PUMP, HYD DRIVEN	VICKERS AEROSPACE
118	MS28759-K-3600		HOSE, RETURN, HYD (30 FT)	
117	MS28759-H-3600		HOSE, PRESSURE, HYD (30 FT)	
116	SERIES 6500		GAUGE, FLUID LEVEL TANK	ROCHESTER GAUGES, INC
115			TANK FILL	AEROQUIP CORP
114			PRESSURE PORT, TANK	
113	FIGG		SIGHT TUBE	TELEDYNE REPUBLIC
112	3205-12		DISCONNECT, RETURN, HYD (-12)	AEROQUIP CORP
111	3205-8		DISCONNECT, PRESSURE, HYD (-8)	AEROQUIP CORP
110			VALVE, TANK DRAIN	
109			VALVE, COOLER BY-PASS	
108			VALVE, THERMAL RELIEF	
107			VALVE, PUSH BUTTON BLEED	
106			VALVE, RELIEF, LOW PRESS	
105			VALVE, MANUAL, BYPASS	
104			VALVE, CHECK	
103			VALVE, HIGH PRESS RELIEF	
102			VALVE, BLEED, TANK	
101			VALVE, SELECTOR, TANK	TELEDYNE REPUBLIC
100	N3-175-0-B		VALVE, SELECTOR, SPEED	DOUBLE A
99			VALVE, SELECTOR, CONTROL	PRODUCTS CO
98			VALVE, DUAL RELIEF	
97	1031008007		MOTOR, PROPULSION	CHAR-LYNN/EATON
96	7559450		FILTER, DRIVE SYSTEM	PURULATOR PRODUCTS
95	7558360		FILTER, CASE DRAIN	PURULATOR PRODUCTS
94	7559450		FILTER, HIGH PRESSURE	PURULATOR PRODUCTS
93	9990 SERIES (AP) IND		FILTER, LOW PRESSURE	AIRCRAFT POROUS MEDIA
92	3880033-1	⚠	COOLER, OIL	
91	PV3-075	⚠	PUMP HYDRAULIC	VICKERS AEROSPACE
90		⚠	HYDRAULIC TANK	
81			RELAY, BATTERY	(MAKE BEFORE BREAK)
80	3890521	⚠	METER, EXHAUST GAS TEMP	
79			SOLENOID, HYD DUMP	
78			TRANSDUCER PNEU PRESSURE	(100 MV OUTPUT)
77			TRANSDUCER HYD PRESSURE	(100 MV OUTPUT)
76			THERMOSWITCH HYD HIGH TEMP	
75			THERMOSWITCH HYD OPER-TEMP	
74	MS27245-1		RELAY NO FUEL	
73			HORN, TOW INTERLOCK	
72			SWITCH, NO FUEL	GEMS CO, INC
71			SWITCH, LOW FUEL	GEMS CO, INC
70	3890525-1	⚠	SWITCH, VOLT-AMP	
69	MS24524-23		SWITCH, PNEU OUTPUT	
68	MS24524-23		SWITCH, HYD OUTPUT	
67	MS24523-23		SWITCH, PANEL LIGHTS	
66	MS24524-27		SWITCH, POWER OUTPUT	

FIND NO	PART NO OR IDENTIFYING NO.	SYM	NOMENCLATURE OR DESCRIPTION	MATERIAL AND SPECIFICATION
---------	----------------------------	-----	-----------------------------	----------------------------

⚠ AIRESEARCH MFG CO.

2

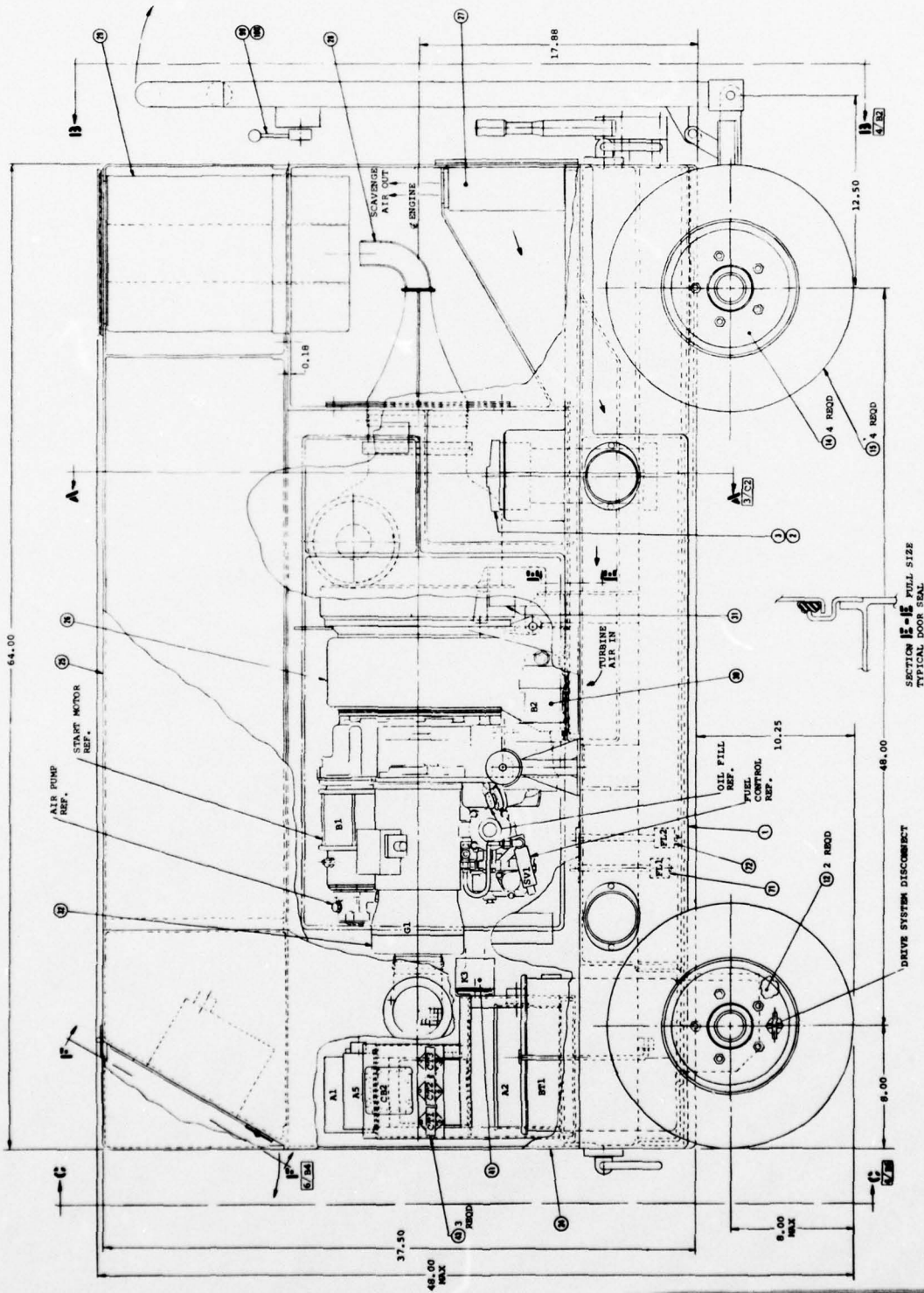
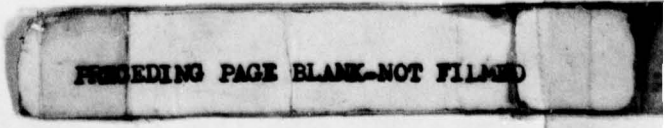

Figure 39. Selected ground power unit, left side cutaway view.



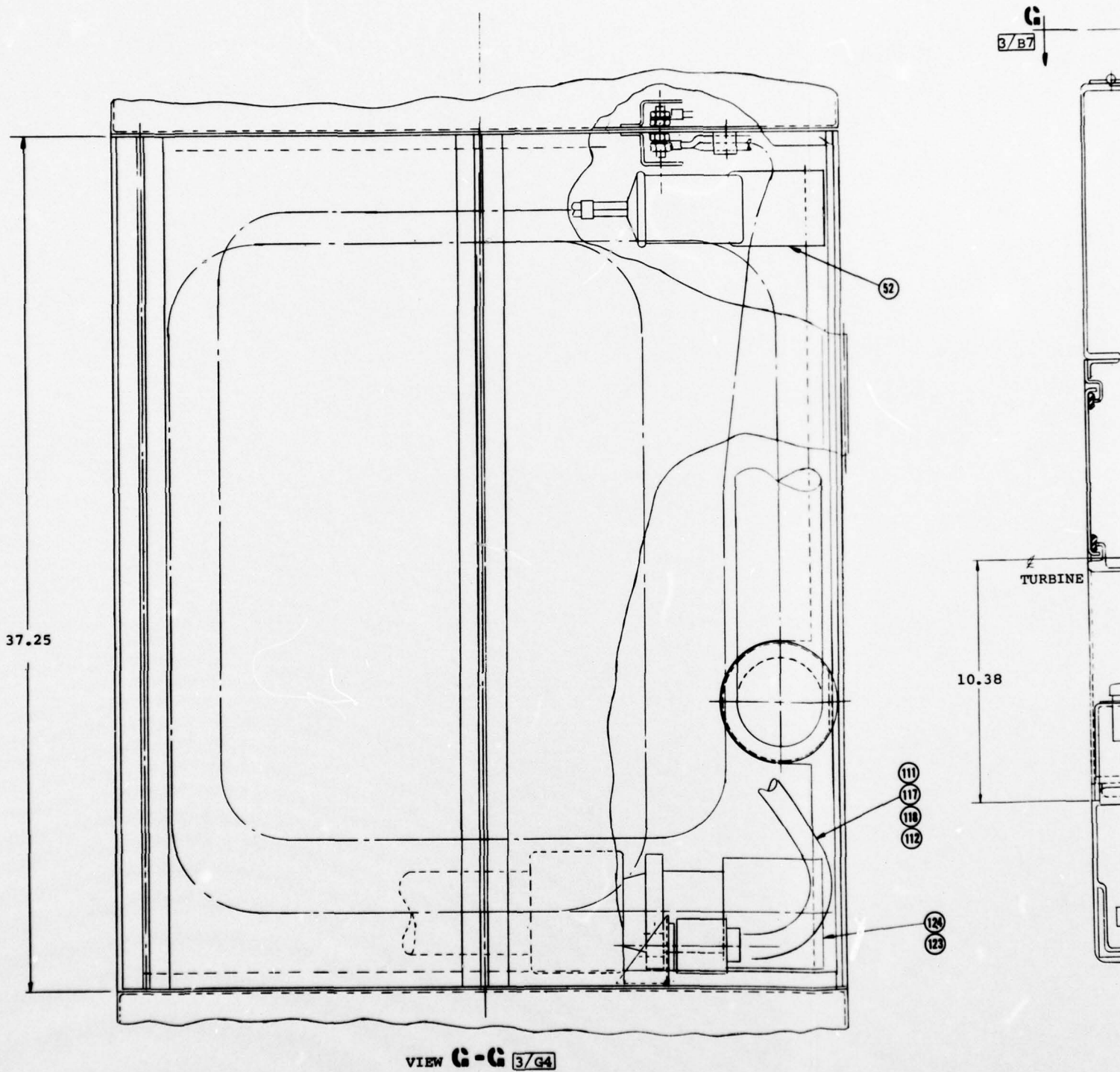
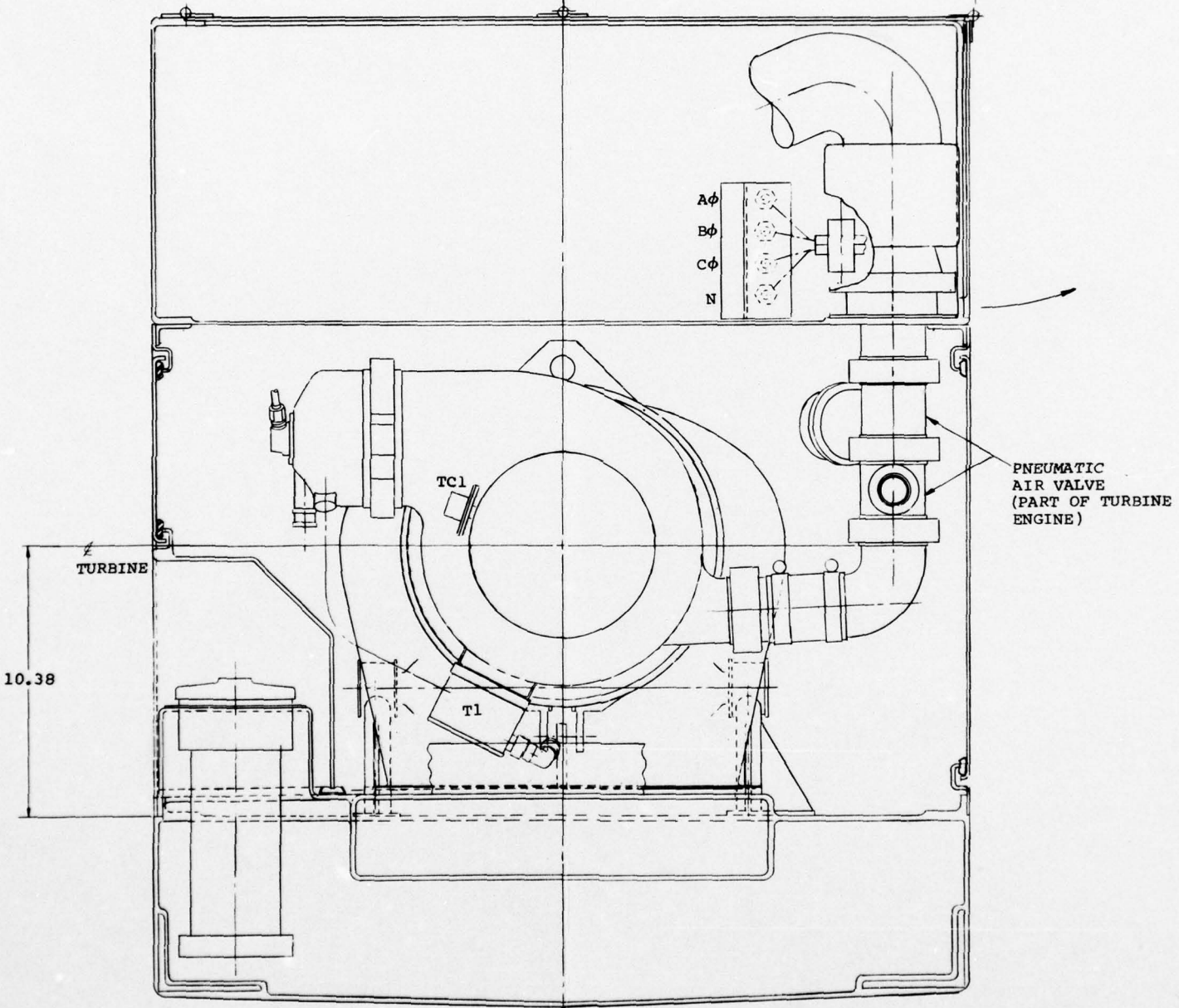

Figure 40. Selected ground power unit, section view.

G  
3/B7

G



VIEW A-A 2/B3

2

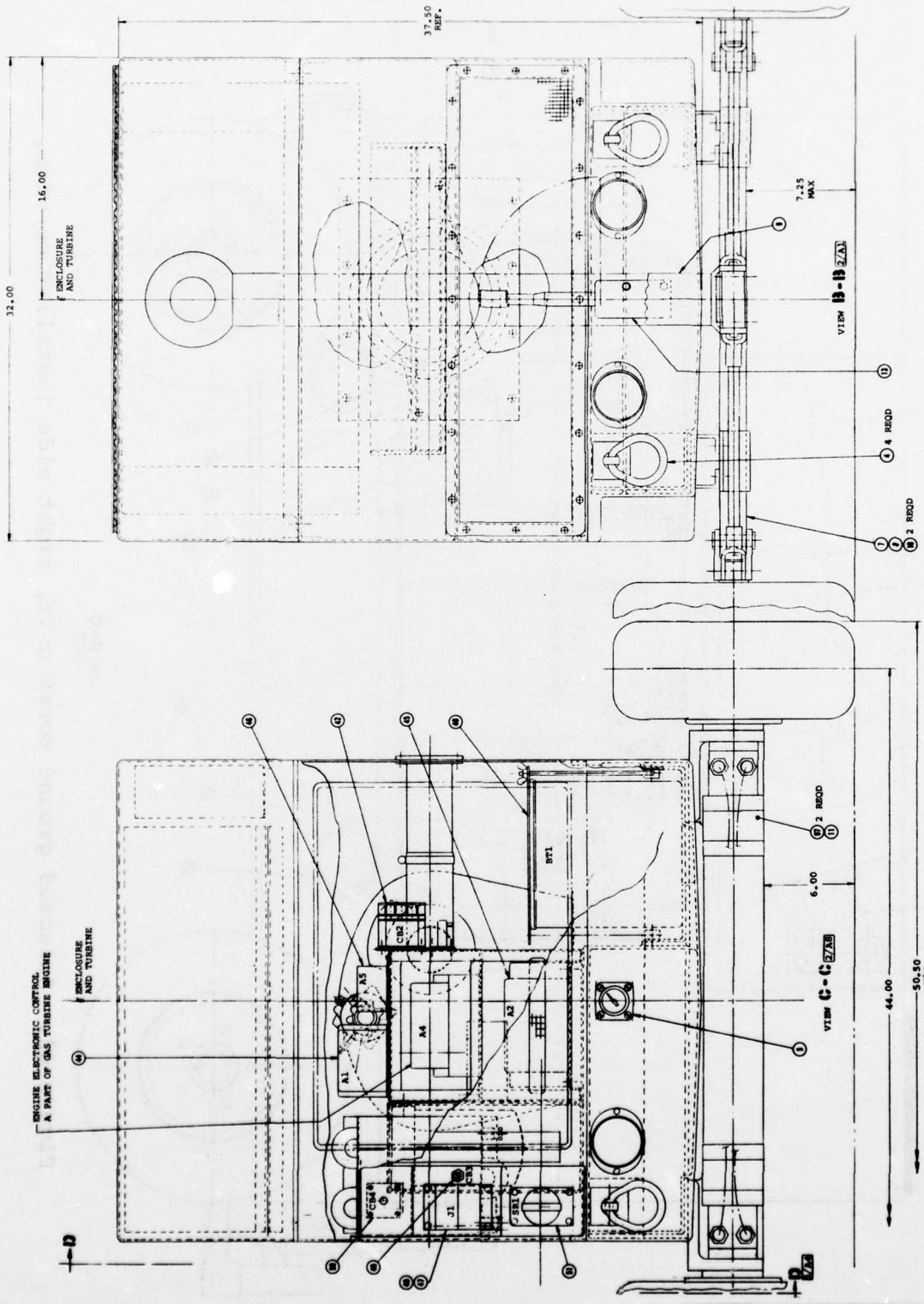
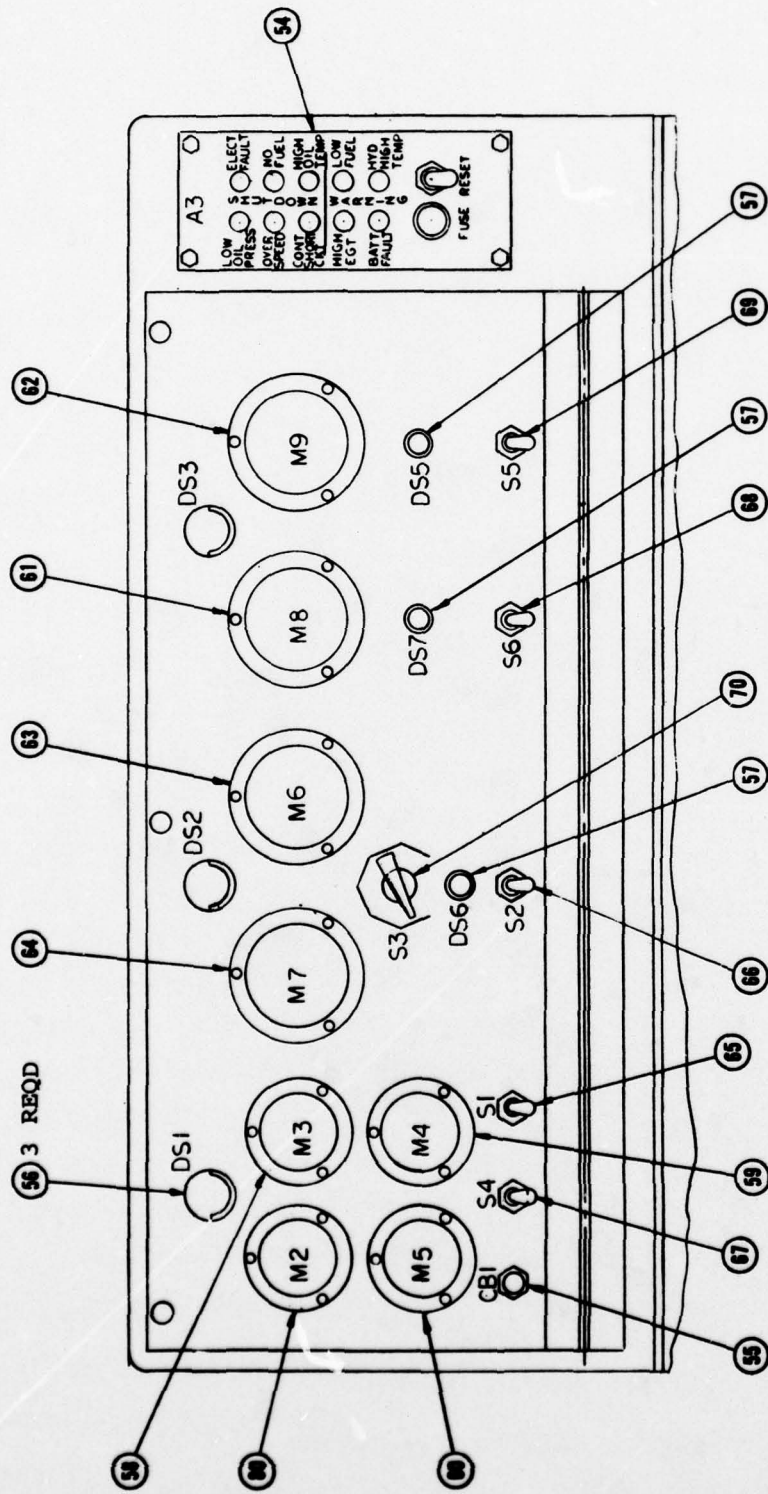

Figure 41. Selected ground power unit, end view.







VIEW **F-F**  
 ROTATED **2/E8**

Figure 43. Selected ground power unit, final instrument and control panel.

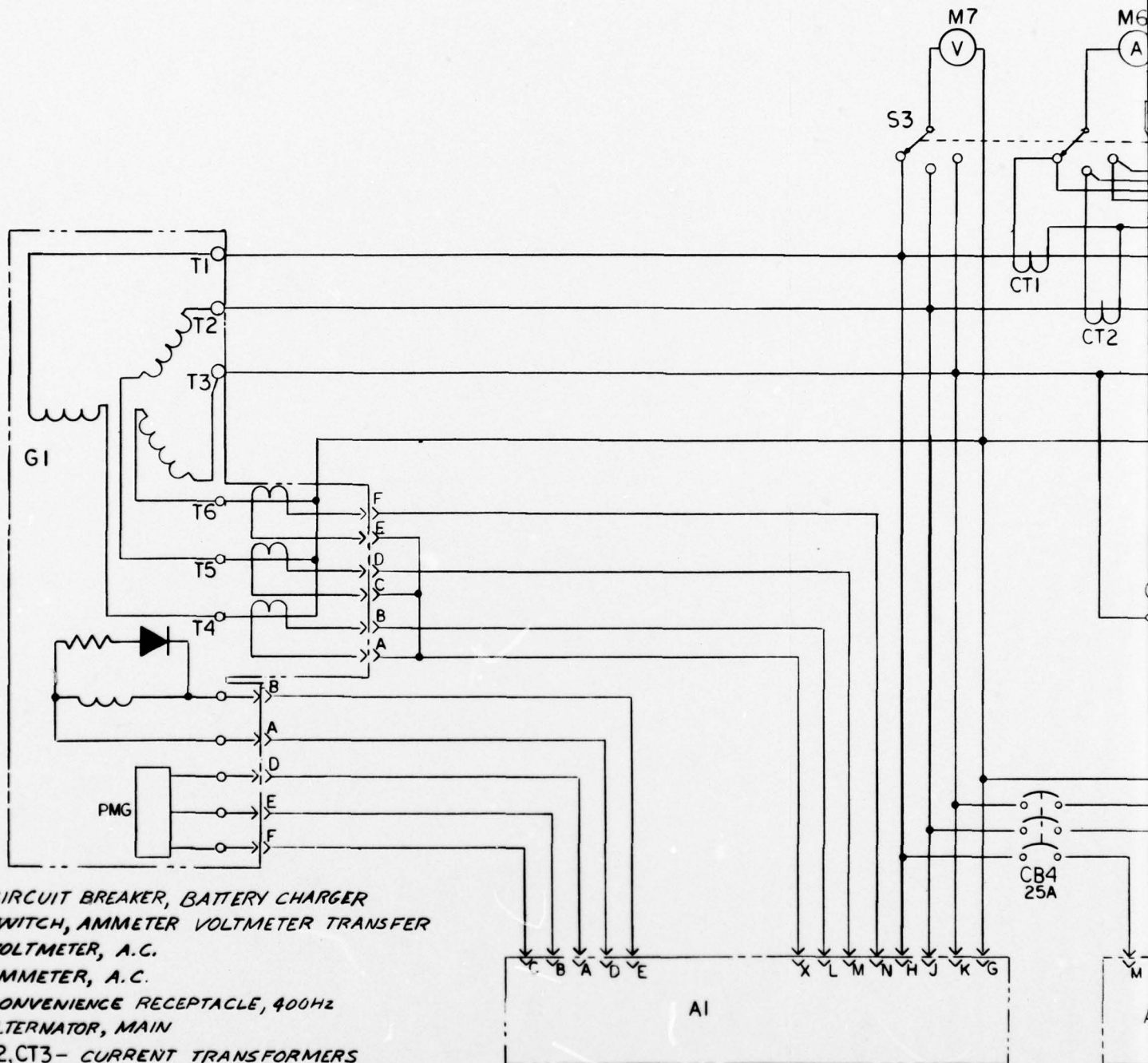

- CB4 - CIRCUIT BREAKER, BATTERY CHARGER
- S3 - SWITCH, AMMETER VOLTMETER TRANSFER
- M7 - VOLTMETER, A.C.
- M6 - AMMETER, A.C.
- J1 - CONVENIENCE RECEPTACLE, 400HZ
- G1 - ALTERNATOR, MAIN
- CT1, CT2, CT3 - CURRENT TRANSFORMERS
- CB3 - CIRCUIT BREAKER, CONVENIENCE RECEPTACLE
- CB2 - POWER OUTPUT CONTACTOR
- A2 - BATTERY CHARGER
- A1 - GENERATOR CONTROL UNIT - VOLTAGE REGULATOR

SEE FIGURE 45

Figure 44. Selected ground power unit, AC circuit wiring schematic.

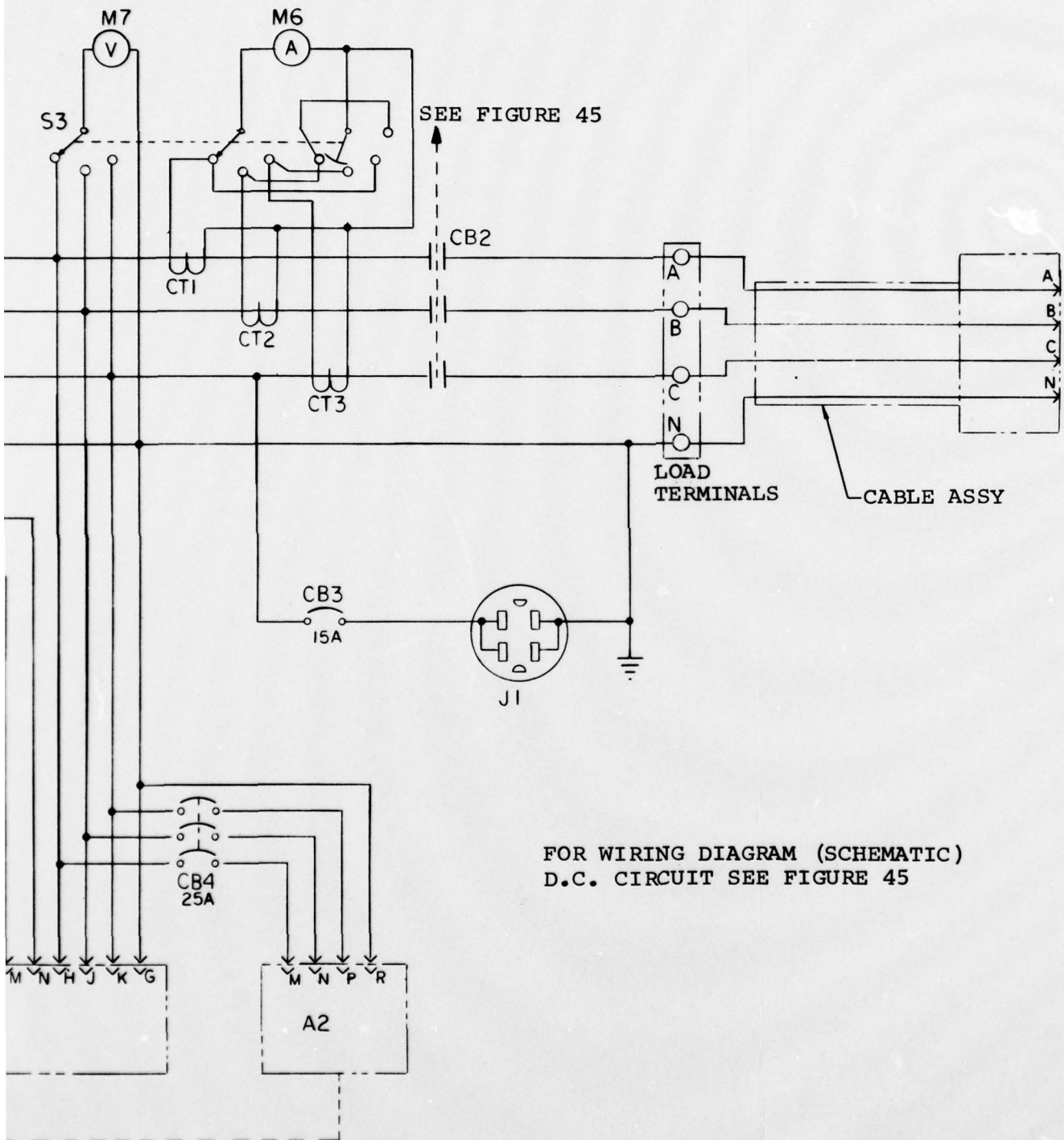

FOR WIRING DIAGRAM (SCHEMATIC)  
 D.C. CIRCUIT SEE FIGURE 45

ic.

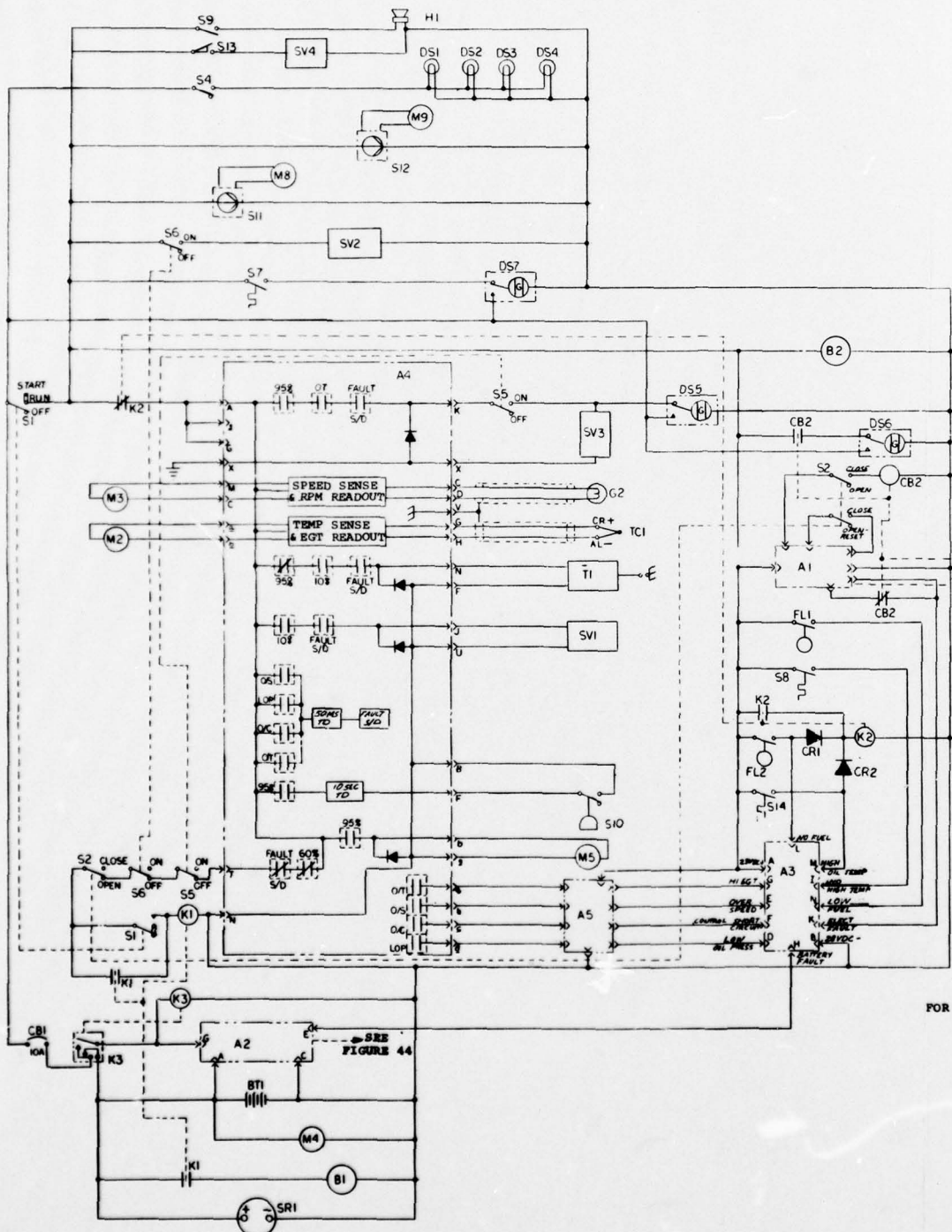

- S14 THERMOSWITCH, HIGH OIL TEMP
- SV4 WHEEL DRIVE SAFETY BY-PASS VALVE
- S13 WHEEL DRIVE INTERLOCK SWITCH
- TC1 THERMOCOUPLE
- T1 IGNITION UNIT
- SRI RECEPTACLE, SLAVE
- SV3 VALVE PNEUMATIC LOAD CONTROL
- SV2 SOLENOID, HYDRAULIC DUMP
- SV1 SOLENOID, FUEL SHUTOFF
- S12 TRANSDUCER, PNEUMATIC PRESSURE
- S11 TRANSDUCER, HYDRAULIC PRESSURE
- S10 SWITCH OIL PRESSURE
- S9 SWITCH, TOW INTERLOCK
- S8 THERMOSWITCH, HYDRAULIC HIGH TEMP
- S7 THERMOSWITCH, HYDRAULIC OPERATING TEMP
- S6 SWITCH, HYDRAULIC OUTPUT
- S5 SWITCH, PNEUMATIC OUTPUT
- S4 SWITCH, PANEL LIGHTS
- S2 SWITCH, POWER OUTPUT CONTACTOR
- S1 SWITCH, MASTER-START-STOP
- M9 METER, PNEUMATIC PRESSURE
- M8 METER, HYDRAULIC PRESSURE
- M5 METER, TOTAL TIME
- M4 METER, BATTERY VOLTS
- M3 METER, SPEED INDICATOR
- M2 METER, EXHAUST GAS TEMPERATURE
- K3 RELAY, BATTERY
- K2 RELAY, NO FUEL
- K1 RELAY, CRANK
- H1 HORN, TOW INTERLOCK
- G2 MONOPOLE
- FL2 SWITCH, NO FUEL SHUTDOWN
- FL1 SWITCH, FUEL LEVEL, LOW
- DS7 LIGHT, HYDRAULIC TEMP OPERATING LEVEL
- DS6 LIGHT, POWER OUTPUT CONTACTOR IND
- DS5 LIGHT, PNEUMATIC LOAD ON
- DS4 LIGHT, UTILITY
- DS1, DS2, DS3 LIGHT, PANEL
- CB2 POWER OUTPUT CONTACTOR
- CB1 CIRCUIT BREAKER, D.C.
- B1 BATTERY, 24V
- B2 MOTOR, FUEL PUMP
- BI MOTOR, STARTER
- A5 FAULT SIGNAL BUFFER
- A4 ENGINE ELECTRONIC CONTROL
- A3 MALFUNCTION INDICATOR PANEL
- A2 BATTERY CHARGER
- A1 GENERATOR CONTROL UNIT-VOLTAGE REGULATOR

FOR WIRING DIAGRAM (SCHEMATIC) A.C. CIRCUIT SEE FIGURE 44

Figure 45. Selected ground power unit, DC circuit wiring schematic.

## 6.0 ADVANCED APU

The purpose of the advanced APU analysis was to determine whether an APU (power plant) employing advanced technology components sized to fit the application could offset the added cost, risk, and complexity inherent in a new engine development program. Potential advantages of the advanced APU included size, weight, cost (potentially both first cost and life-cycle cost through reduced fuel consumption), reliability, and maintainability. These advantages were predicated on the assumption that, using current design and manufacturing technology, the engine was designed specifically for the application rather than selected from a variety of available off-the-shelf power plants near the required power class.

### 6.1 Parametric Analysis

Technology incorporated in this study represented low cost aerodynamics, manufacturing, and metallurgy available in calendar year 1977. For this study, all configurations considered utilized cast turbine and compressor wheels, metallic annular combustors, hot-end foil journal bearings, and compact plate-fin counterflow recuperators (where applicable), and are single-spool, constant speed engines.

Required GPU outputs at two operating conditions are shown below:

	<u>Point A</u>	<u>Point B</u>
Pressure altitude	Sea level	10,000 ft
Ambient temperature	125°F	64°F
Pneumatic output	34 lb/min at 47.2 psia	26.5 lb/min at 34.1 psia
Mechanical output	59 shp	59 shp

System analysis indicated that altitude point (B) was the limiting condition.

Requirements for both mechanical and pneumatic output were met by several different APU systems as follows:

- o Pure Shaft Power APU - Required a load compressor mounted on the gearbox, but permitted optimizing power section performance.

- o Integral Bleed APU - With a wide-range compressor, eliminated need for a load compressor and surge valve, but compromised power section performance optimization.
- o Integral Bleed APU - With a variable diffuser, permitted a smaller APU than with the wide range compressor.
- o Interstage Bleed APU - Permitted optimizing power section performance while supplying required pneumatic power, but required both variable diffuser and a second compressor stage.

Recuperation was considered as a possible option for both shaft-power and integral bleed APUs. In addition to reducing fuel consumption, the recuperator provided muffling for turbine and combustor exhaust noise, and therefore, could eliminate additional exhaust noise treatment. However, the recuperator could not occupy more volume than the volume of the muffler replaced plus fuel saved.

Figures 46 through 50 represent the parametric performance of a pure shaft power APU without and with recuperation. Turbine inlet temperature levels represent equal incremental gains (75°F) from AiResearch GTCP36-50 levels to the 2050°F level to be demonstrated by the AiResearch GTP305-2 advanced APU program. A turbine inlet temperature of 1975°F was selected as a low risk production value for 1977 since this temperature was only moderately higher than temperatures demonstrated with a cooled nozzle in an engine in 1975.

Thermodynamic cycle analysis of integral bleed engines with wide-range and variable diffuser compressors permitted the performance comparison shown in Table 24.

With bleed pressure requirements met by the low pressure compressor, the overall pressure ratio of the interstage bleed APU could be varied to minimize power section size. Results of this parametric analysis are shown in Figure 51.

## 6.2 Preliminary System Selection

A performance comparison of the four types of non-recuperated APUs is shown in Table 25.

Comparing integral bleed type systems, with and without variable diffusers, indicated that the variable diffusers

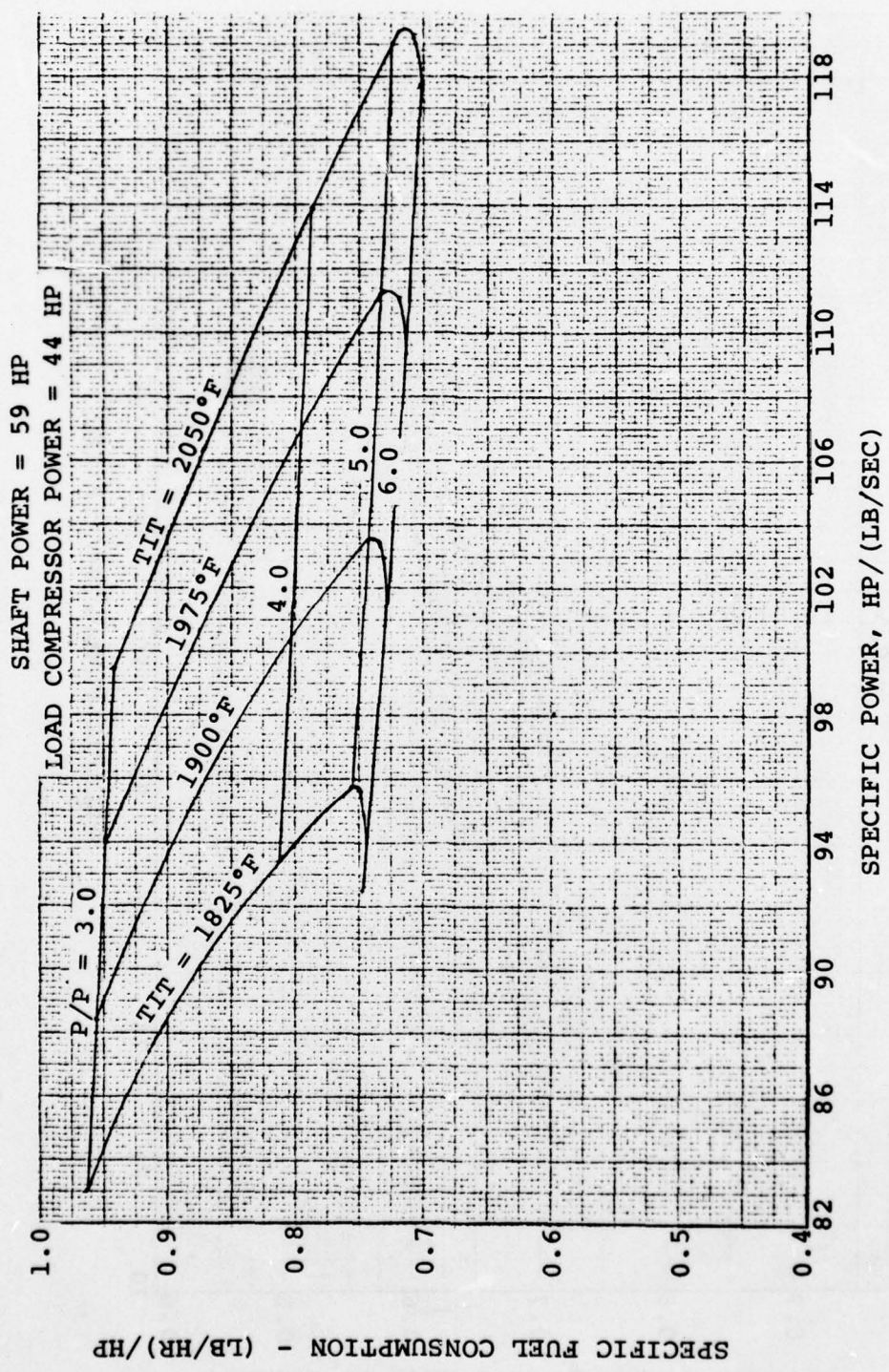

Figure 46. Nonrecuperated engine with load compressor.

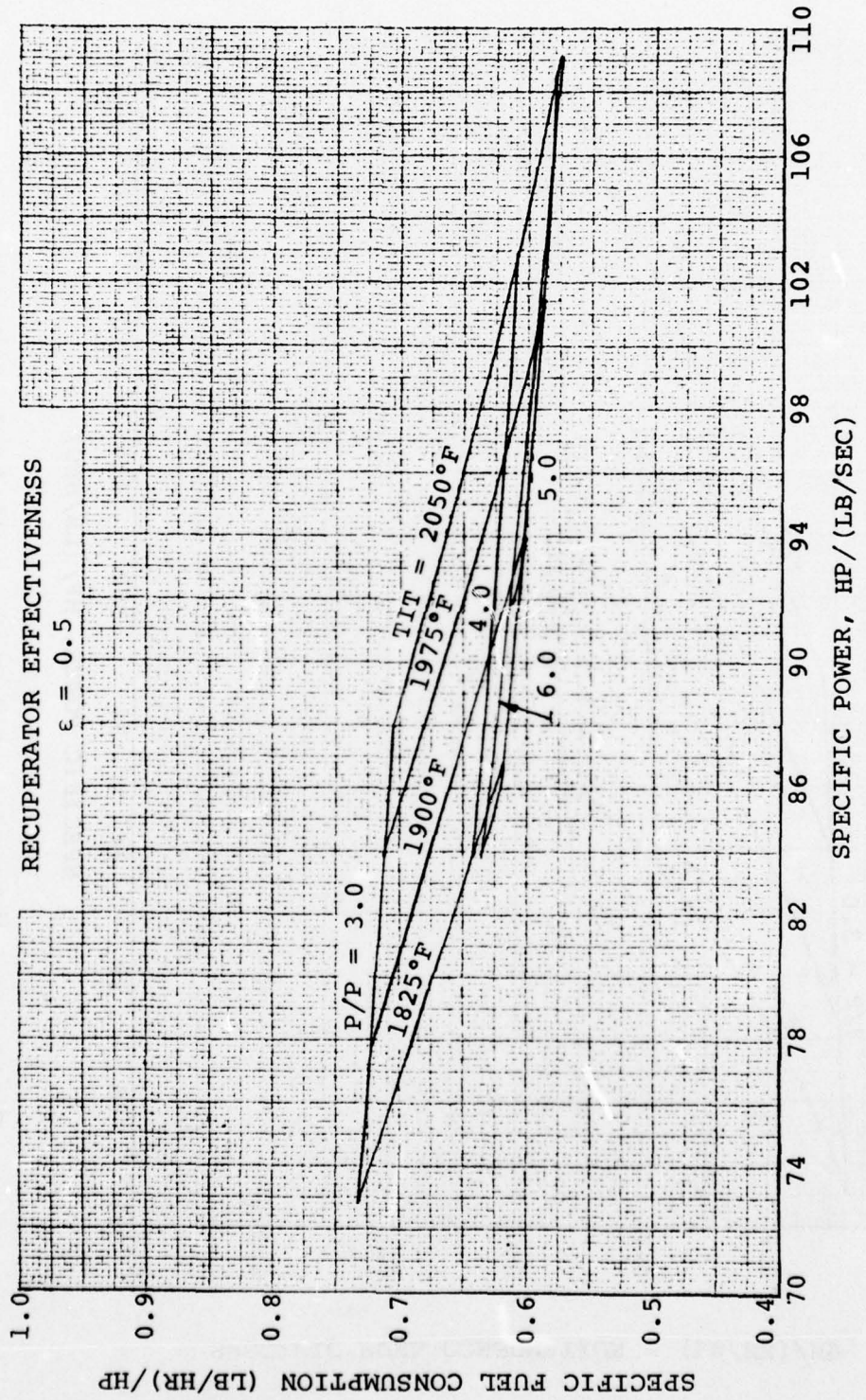

Figure 47. Recuperated engine with load compressor.

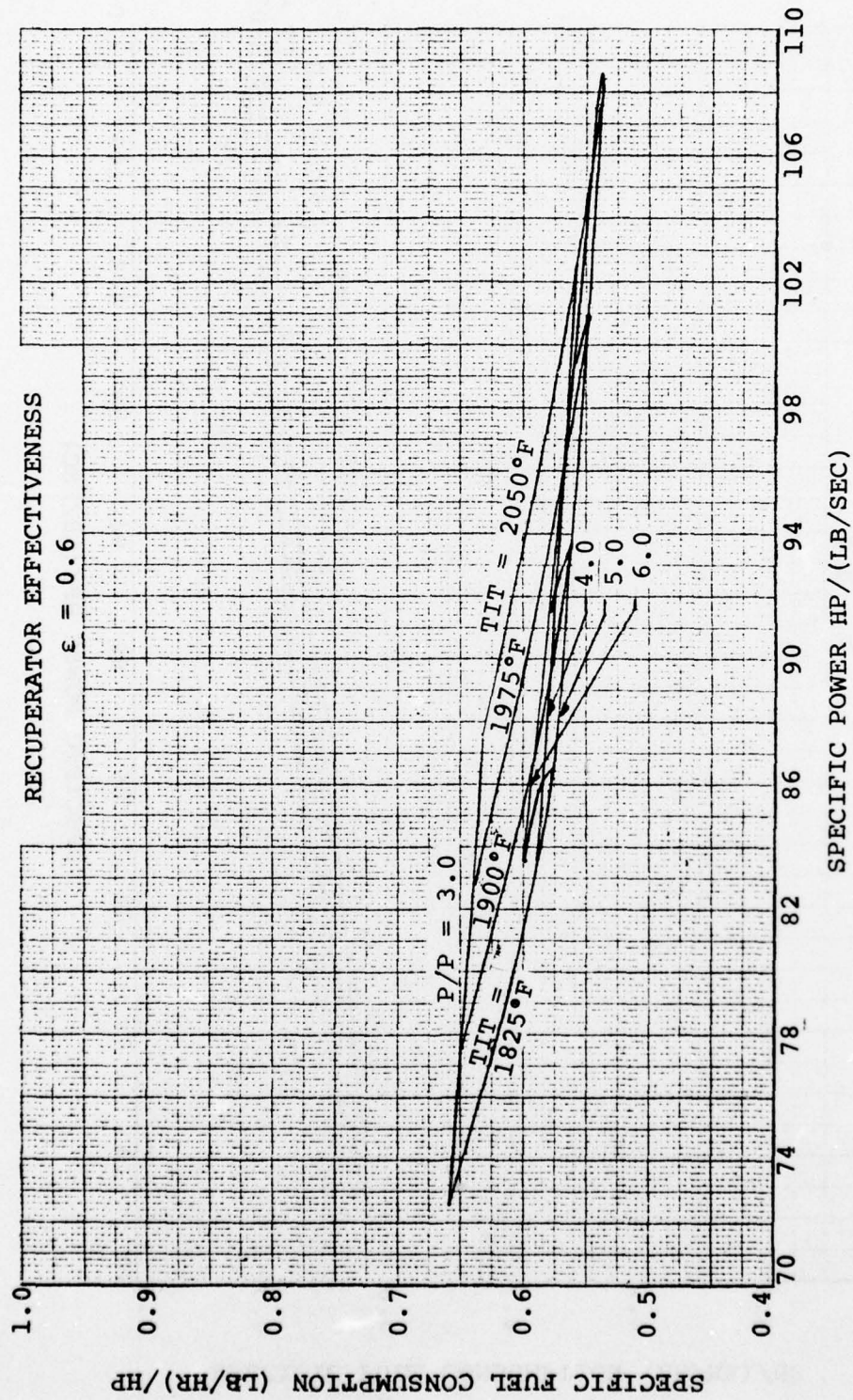

Figure 48. Recuperated engine with load compressor.

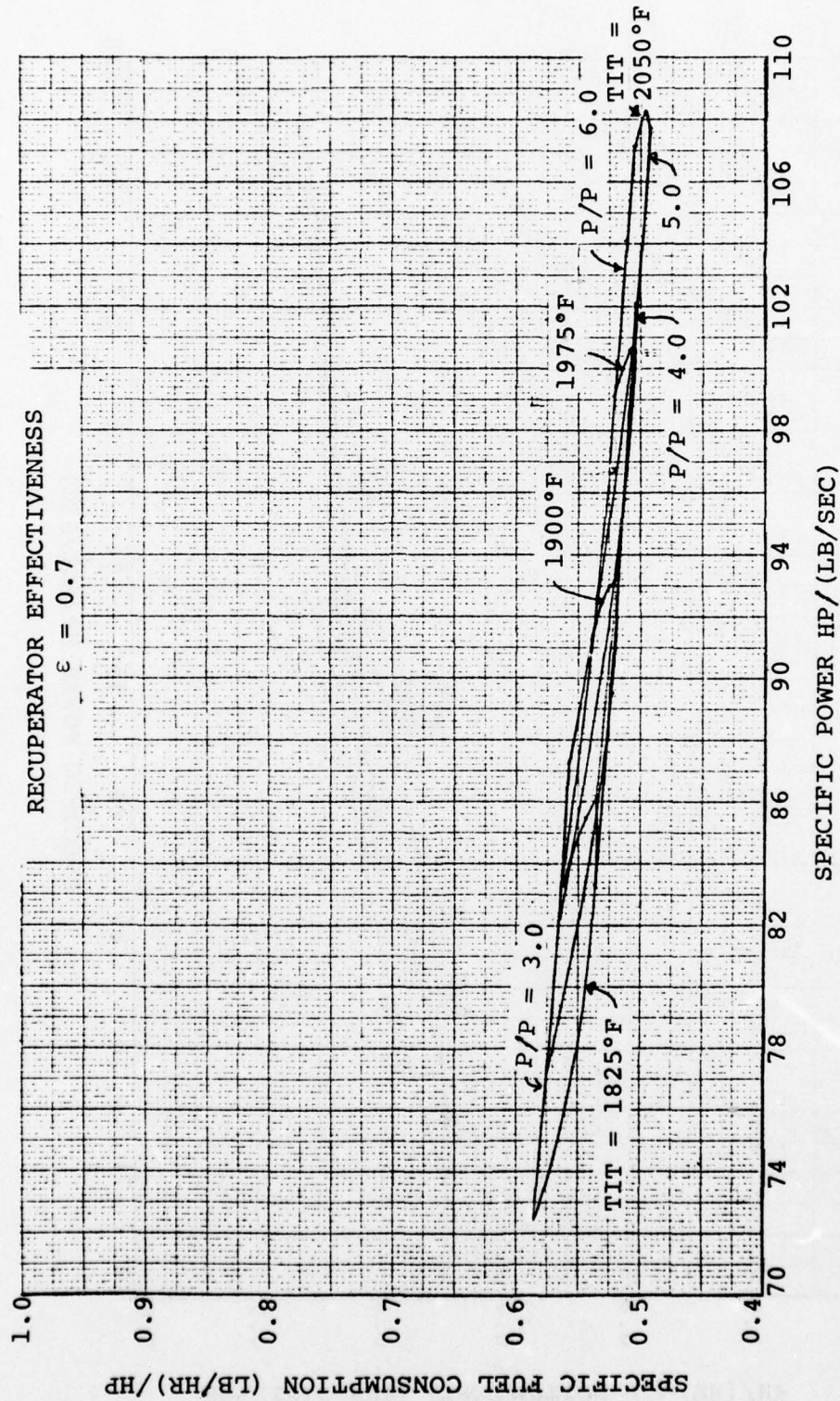

Figure 49. Recuperated engine with load compressor.

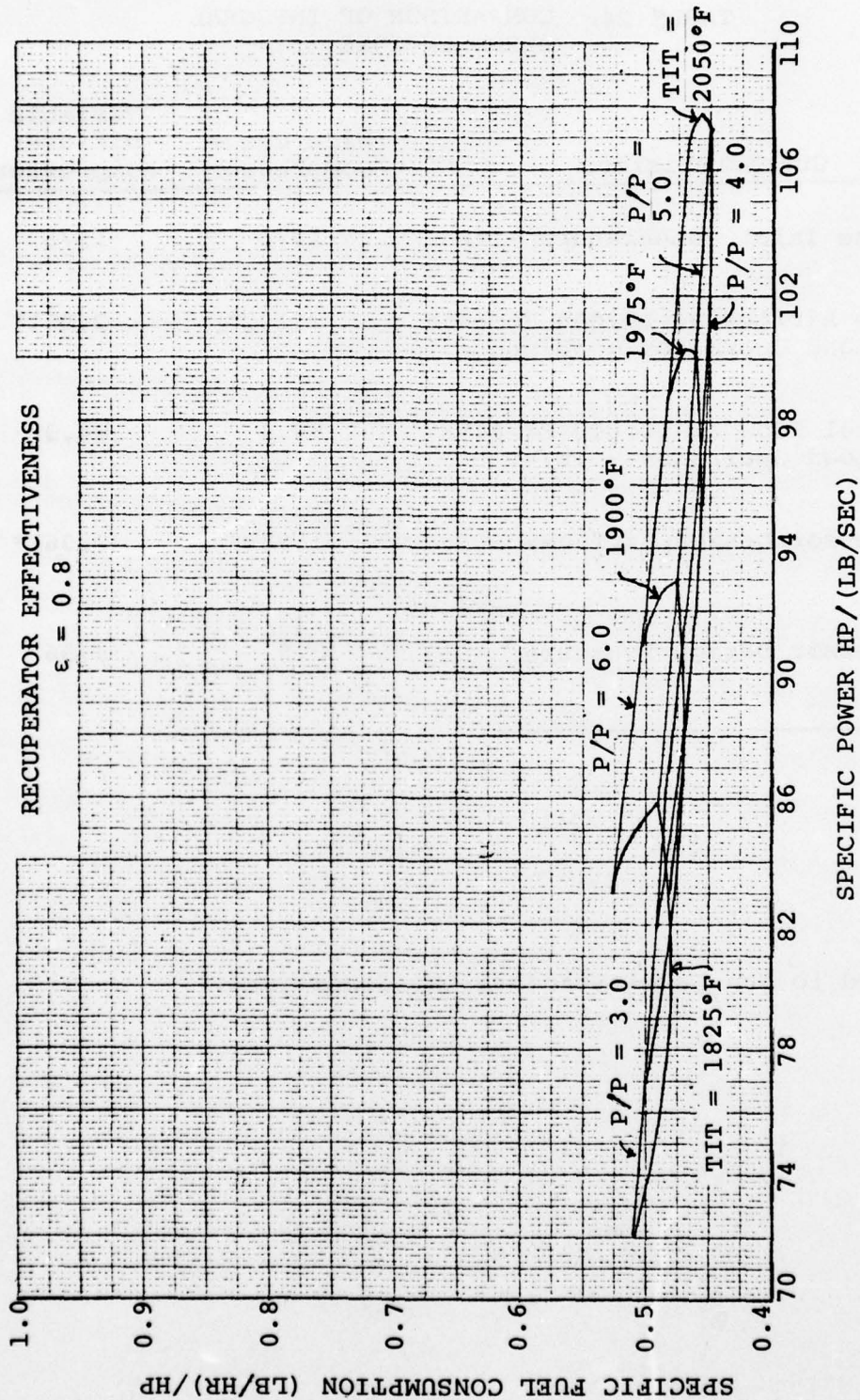

Figure 50. Recuperated engine with load compressor.

TABLE 24. COMPARISON OF INTEGRAL BLEED ENGINES

Characteristics	Wide Range Compressor	Variable Diffuser Compressor
Turbine Inlet Temperature - °F	1975	1975
Engine Airflow at 10,000 Ft 64°F Full Load Operation - lb/sec	2.102*	2.061*
APU Fuel Flow at 10,000 Ft 64°F Full Load Operation - lb/hr	86.4	84.3
Compressor Design Airflow, lb/sec	1.980*	2.061*
Compressor Design Pressure Ratio	3.8	3.56

\*Corrected to Sea Level Standard Day Conditions.

2-STAGE CENTRIFUGAL COMPRESSOR  
INTERSTAGE BLEED                      VARIABLE DIFFUSER

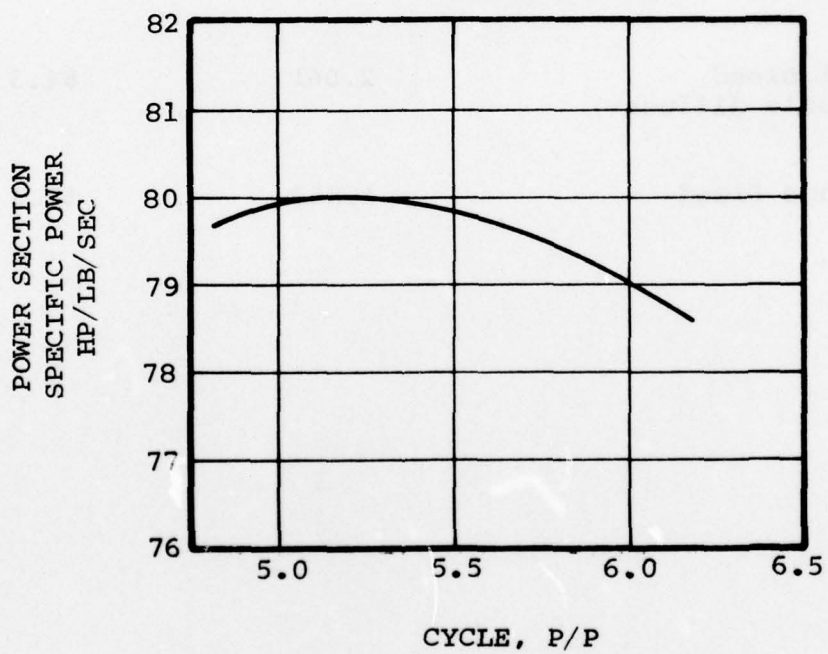

Figure 51. Interstage bleed APU parametric analysis.

TABLE 25. MAXIMUM POWER APU COMPARISON  
AT 10,000 FEET, 64°F

Engine Type	Required Corrected Airflow lb/sec	Required Fuel Flow lb/hr
Shaft Power	1.374	77.0
Integral Bleed (wide range compressor)	2.102	86.4
Integral Bleed (variable diffuser)	2.061	84.3
Interstage Bleed	1.863	67.3

provide a modest (2.4 percent) improvement in maximum power fuel consumption, but would not significantly reduce APU size or weight. Incorporating variable diffusers would increase the basic APU and control system cost and likely reduce reliability. In light of projected first cost increases, fuel savings appeared insignificant, and eliminating the variable diffuser system from further consideration was justified.

The attractiveness of the interstage bleed APU was diminished by requirements for: (1) variable diffuser, (2) second compressor stage, and (3) second turbine stage. This type would have a higher cost, lower reliability, increased length, and likely increased weight relative to other options. These projected penalties also eliminated this system as a possible option.

### 6.3 Final Systems Analysis

To determine the worth of system recuperation, heat exchangers for both shaft power and integral bleed APUs were sized. Weight and volume as functions of recuperator effectiveness are shown in Figures 52 and 53. This information was used for a recuperator/acoustic treatment trade-off analysis. Systems evaluated are shown in Table 26.

The primary acoustic benefit of using recuperation was to reduce the hard-to-muffle low-frequency combustion-generated noise. Noise was reduced as effectiveness increased because the combustor temperature rise was reduced. The predicted combustion source noise for the engines of Table 27 is shown in Figure 54.

For each APU type, a muffler was sized that would quiet the nonrecuperated APU to the same noise level as the 0.5 and 0.8 effectiveness recuperated APU. This muffler sizing was done using actual noise suppression test data and theoretical calculations. The recuperators for these same systems using the lightweight and more compact, but heavier designs, is shown along with the muffler data in Table 28. Using this data and assuming a 2-hour maximum power fuel requirement, the system volume trade-off, assuming the most optimistic mufflers and larger recuperators, is shown in Table 29. A weight analysis comparing the fuel used against recuperator core weight is shown in Table 30. This table illustrates that this mission would permit recuperated engines to provide significant weight savings.

PRELIMINARY RECUPERATOR SIZING  
 PARAMETRIC CYCLES AT 5:1 P/P 1975°F TIT  
 SHAFT POWER ENGINES

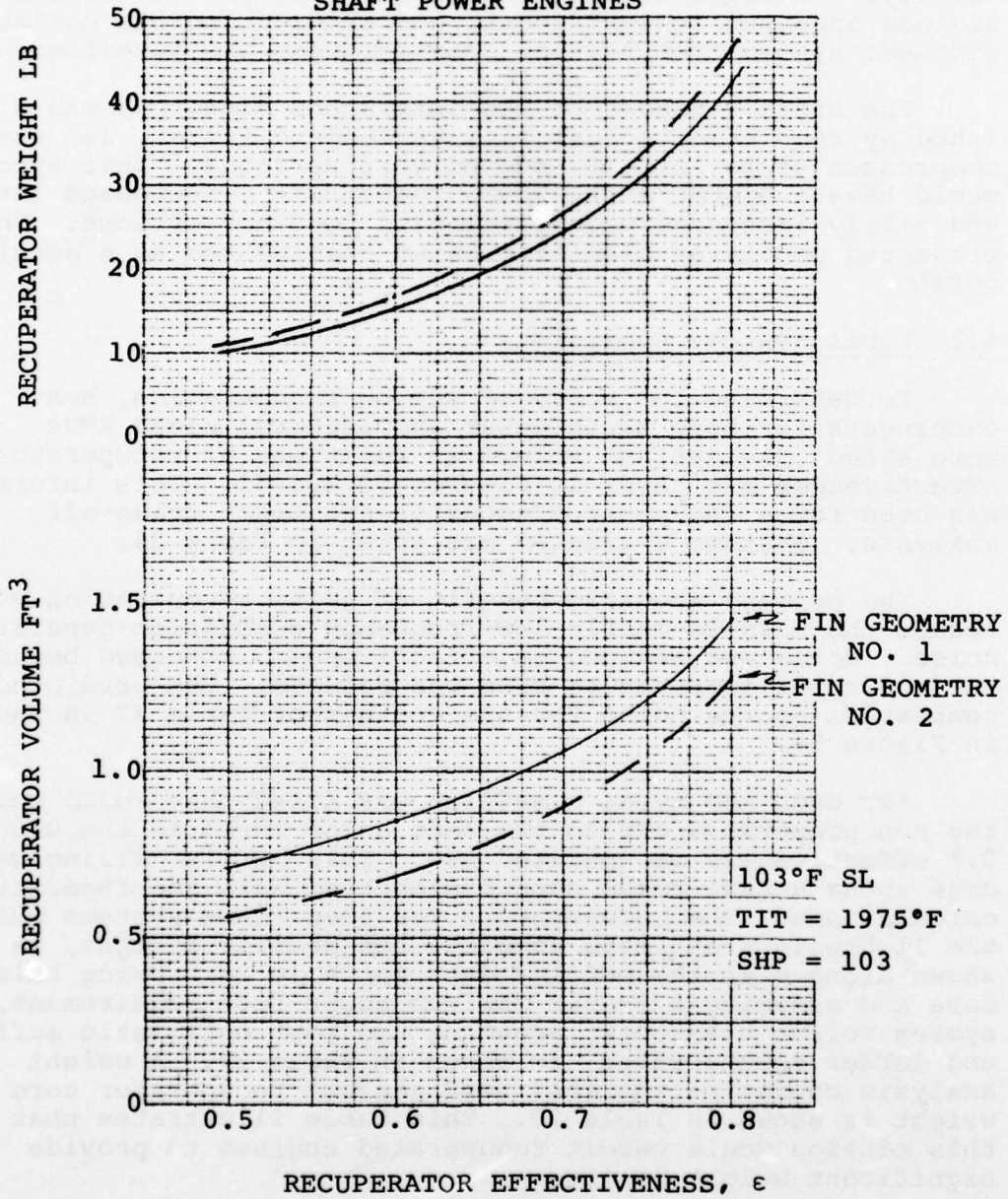

Figure 52. Recuperator sizing study.

PRELIMINARY RECUPERATOR SIZING  
 PARAMETRIC CYCLES AT 3.5:1 P/P, 1975°F TIT

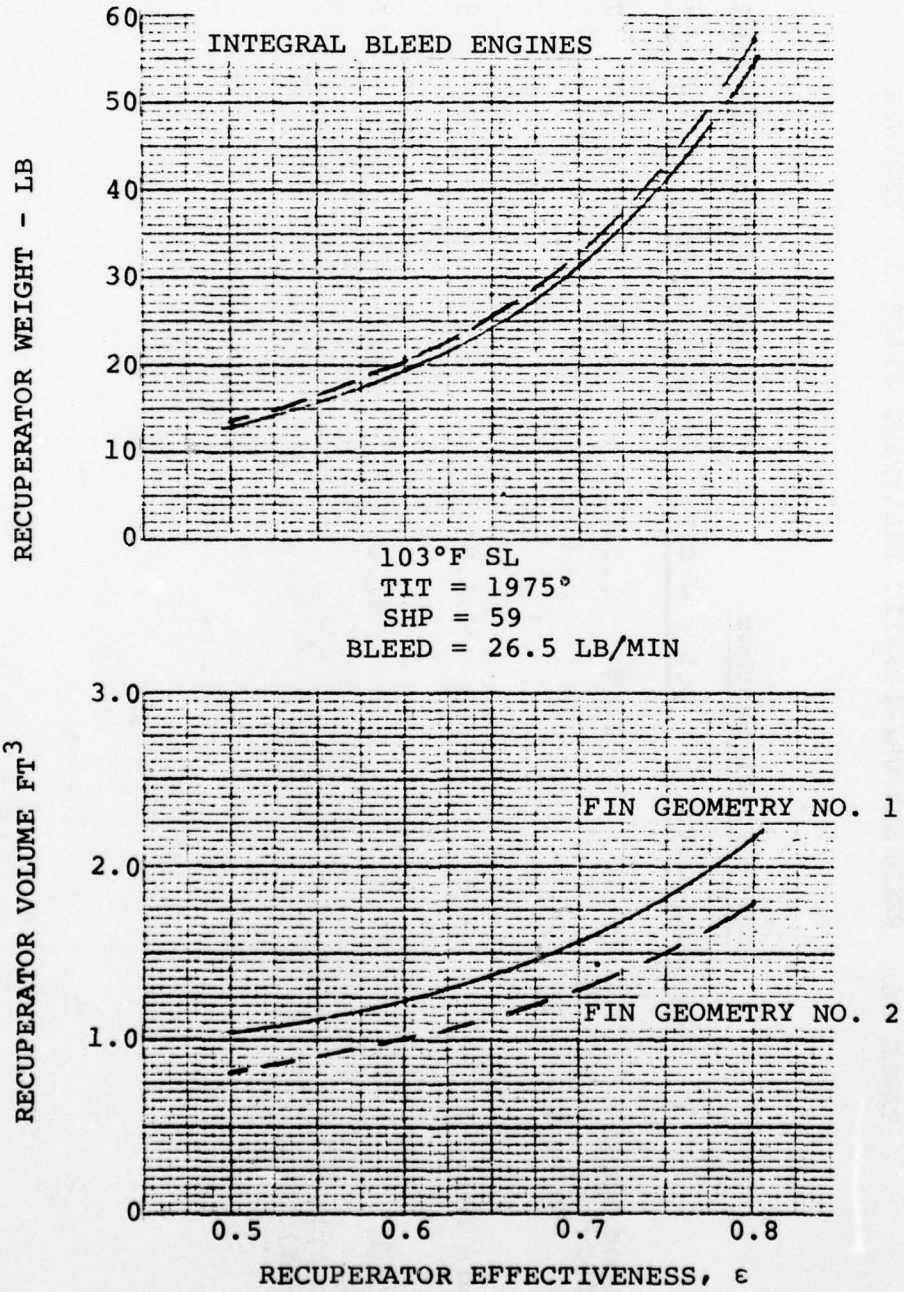

Figure 53. Recuperator sizing study.

TABLE 26. RECUPERATOR/ACOUSTIC TREATMENT TRADE-OFF ENGINES

	<u>Shaft Power Systems</u>		<u>Integral Bleed Systems</u>	
	No Recuperator $\epsilon = 0.5$	$\epsilon = 0.8$	No Recuperator $\epsilon = 0.5$	$\epsilon = 0.8$
Full Load Engine Airflow $W/\theta/\delta$ (lb/sec)	1.37	1.49	1.51	2.10
Pressure Ratio	5.0	5.0	5.0	3.6
Full Load Fuel Consumption (lb/hr)	77.0	61.0	47.6	86.4
			2.28	2.30
			3.6	3.6
			66.1	47.7

TABLE 27. VOLUME COMPARISONS

APU Configuration	At $\epsilon_R = 0.5$ Noise Level		At $\epsilon_R = 0.8$ Noise Level	
	No Recuperator	$\epsilon_R = 0.5$	No Recuperator	$\epsilon_R = 0.8$
<u>Bleed APU Systems</u>				
Recuperator Volume, ft <sup>3</sup>	--	1.1	--	2.2
Muffler Volume, ft <sup>3</sup>	1.4	--	2.7	--
Fuel Volume, ft <sup>3</sup>	<u>3.5</u>	<u>2.7</u>	<u>3.5</u>	<u>2.0</u>
BLEED APU TOTAL	4.9	3.8	6.2	4.2
<u>Shaft APU Systems</u>				
Recuperator Volume, ft <sup>3</sup>	--	0.7	--	1.5
Muffler Volume, ft <sup>3</sup>	1.1	--	1.8	--
Fuel Volume, ft <sup>3</sup>	<u>3.1</u>	<u>2.5</u>	<u>3.1</u>	<u>1.9</u>
SHAFT APU TOTAL	4.2	3.2	4.9	3.4

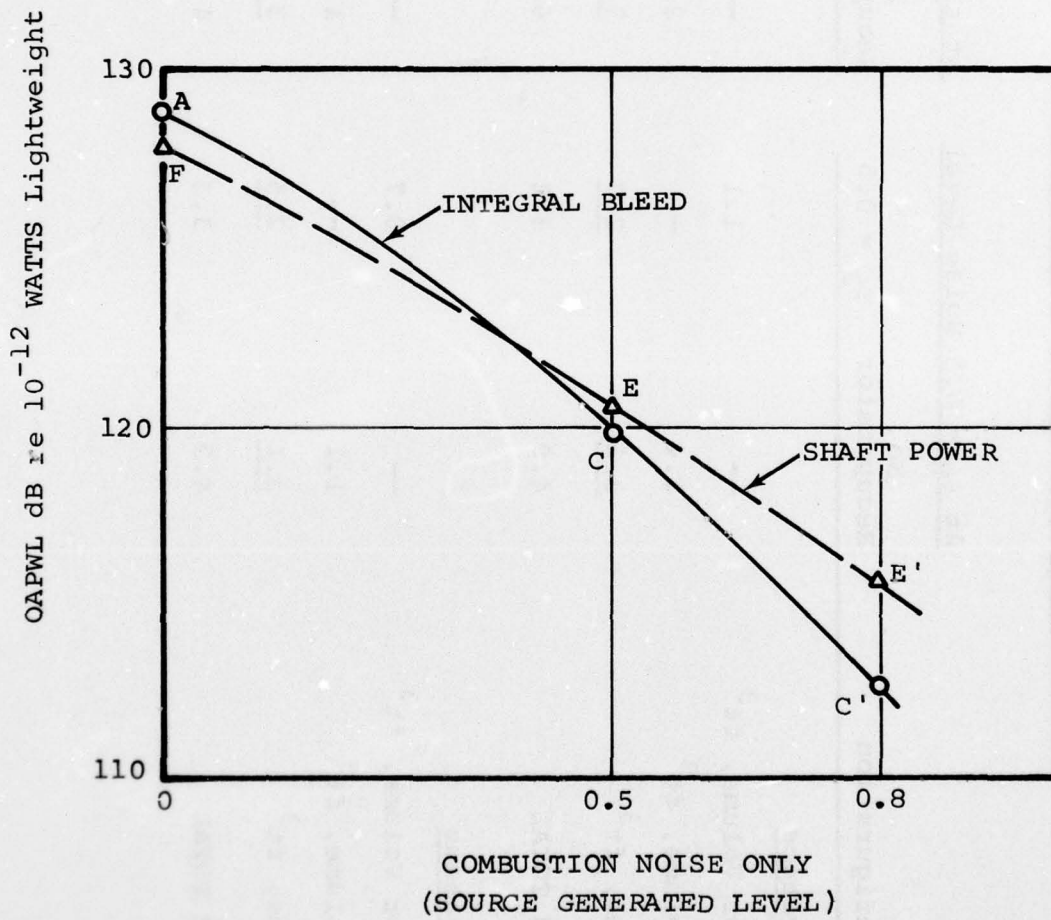

Figure 54. Predicted acoustics for advanced APU.

TABLE 28. MUFFLER VOLUMES - FT<sup>3</sup>

	Based on Test Data	Theoretical Value
<b>Bleed APU</b>		
Muffled to 0.5 $\epsilon_R$	2.0	1.4
Muffled to 0.8 $\epsilon_R$	3.6	2.7
<b>Shaft APU</b>		
Muffled to 0.5 $\epsilon_R$	1.5	1.1
Muffled to 0.8 $\epsilon_R$	2.5	1.8

TABLE 29. RECUPERATOR VOLUMES - FT<sup>3</sup>

	Lightweight Core Design	Heavy Core Design
<b>Bleed APU</b>		
0.5 $\epsilon_R$	1.05	0.80
0.8 $\epsilon_R$	2.16	1.80
<b>Shaft APU</b>		
0.5 $\epsilon_R$	0.71	0.57
0.8 $\epsilon_R$	1.46	1.28

TABLE 30. WEIGHT ANALYSIS

	$\epsilon_R = 0$	$\epsilon_R = 0.5$	$\epsilon_R = 0.8$
<b>Bleed APU</b>			
Recuperator Core, lb	--	13.0	55.0
Fuel Weight, lb	172.8	132.2	95.4
<b>BLEED APU TOTAL</b>	<b>172.8</b>	<b>145.2</b>	<b>150.4</b>
<b>Shaft APU</b>			
Recuperator Core, lb	--	10.0	42.0
Fuel Weight, lb	144.0	122.0	95.2
<b>SHAFT APU TOTAL</b>	<b>144.0</b>	<b>132.0</b>	<b>137.2</b>

Use of a shaft power APU driving a gearbox-driven load compressor would require a load compressor, load compressor control devices, and a more complex gearbox for implementation than would the integral bleed system. Therefore, a shaft power APU system would have more parts, higher complexity, and a more complex control system, which, for this application, would result in increased cost and lower reliability. For these reasons, the advanced APU selected is of the integral bleed type.

The data presented indicates that the muffler/recuperator trade-off is decided in favor of recuperators. The data also indicates that both the weight and volume penalties for  $\epsilon_r = 0.8$  relative to  $\epsilon_r = 0.5$  designs are small. Life-cycle fuel savings for the highest effectiveness system would be significant; therefore, the  $\epsilon_r = 0.8$  recuperator will be used.

## 7.0 CONCLUSIONS AND RECOMMENDATIONS

This analysis verified that a need exists for a mobile, lightweight, multi-output ground power unit for AAH, UTTAS, and CH-47D. The study also illustrated the lack of equipment in current U.S. Army inventory with even single- or dual-output to provide the pneumatic ground service requirements for current and future inventory aircraft. The gas-turbine-driven, self-propelled, air-transportable GPU described as a result of this study meets and fulfills all of these needs.

The recommended advanced APU for this GPU system is an integral bleed machine incorporating a single-stage radial compressor, a single-stage radial turbine, and a compact 0.8 effectiveness, plate-fin counterflow recuperator.

Several areas outside the scope of this contract, but worthy of continued study were identified during the conduct of the advanced GPU program. These areas include:

- (a) Infrared - As noted in Para. 3.2.13, GPU infrared (IR) characteristics were evaluated and found to exceed the aircraft allowable limits. However, no IR characteristics are defined for the GPU. Therefore, it is recommended that GPU IR limits be defined as part of a separate study, and an optimum IR suppression scheme be established for the GPU.
- (b) Advanced APU - Due to funding limitations, the advanced APU study was terminated before all originally anticipated work was completed. Several interesting subject areas warrant further investigation, including:
  - o Recuperation/Sound Attenuation - The addition of a recuperator to a gas turbine was found to significantly reduce sound noise generated in addition to normal attenuation. This effect was most pronounced in the difficult-to-treat low-frequency (combustor) noise area. It would be desirable to continue this study and test on a component basis to provide a complete evaluation of this concept. A future study could consider both engine and component testing.
  - o Size and Weight Comparison - The size and weight of the recommended advanced APU configuration were not established. It would be

interesting to complete this study and then conduct a trade-off to evaluate life-cycle cost effects including development of the lighter, smaller, more economical advanced technology unit against the already developed current technology unit selected and illustrated in Figures 38 through 43.

APPENDIX A  
QUESTIONNAIRES

Airframe questions - UTTAS

Is there a hard point to sling lift the GPU?

Allowable GPU weight (2900 lbs?)

Can the GPU be stowed on board-cargo door opening size

A/C interface description

Electric

Hydraulic

Pneumatic

Parallel requirements

Generator description

Manfr - P/N

Size

Electrical System description

Weight

Speed

Dir of rotation

Cooling

GCU

Manfr - P/N

Size

Weight

CT's

Contractor

Hydraulic pump

Manfr. - P/N

Hydraulic System description

Weight

Speed

Dir of rotation

Mounting pad

Accumulator

Manfr -P/N

Size

Weight

Filter

Manfr. P/N

Size

Weight

Rating

Load requirements

GPU not APU

Max elect

Max

Max combined shaft & bleed -

Individual

Max combined shaft load (hyd & elec

Fault Clearance?

Max hyd

bleed load -

How are loads supplied on the A/C

GPU system description -

Elect.

Hyd.

Pneu.

Maintenance Concepts/Philosophy -

IR requirements

Review GPU layout -

Service cable length

**Airframe questions - AAH**

**Is there a hard point to sling lift the GPU?  
Allowable GPU weight (1140 lbs?)**

**A/C interface description**

**Electric**

**Hydraulic**

**Pneumatic**

**Parallel requirements**

**Generator description**

**Manfr - P/N**

**Size**

**Weight**

**Speed**

**Dir of rotation**

**Cooling**

**Manfr - P/N**

**Size**

**Weight**

**Electrical System description**

**GCU**

**CT's**

**Contractor**

**Hydraulic pump**

**Hydraulic System description**

**Manfr. - P/N**

**Weight**

**Speed**

**Dir of rotation**

**Mounting pad**

**Accumulator**

**Manfr -P/N**

**Size**

**Weight**

**Filter**

**Manfr. P/N**

**Size**

**Weight**

**Rating**

**Load requirements**

GPU not APU

Max elect

Max

Max combined shaft & bleed -

**Individual**

Max combined shaft load (hyd & elec

Fault Clearance?

Max hyd

bleed load -

How are loads supplied on the A/C

GPU system description -

Elect.

Hyd.

Pneu.

Maintenance Concepts/Philosophy -

IR requirements

Review GPU layout -

Service cable length

## APPENDIX B

### PROBLEM STATEMENT

#### SYSTEM PERFORMANCE AND DESCRIPTION REQUIREMENTS

##### 400-HZ GENERATING SYSTEM

- Application:** To be mounted on and driven by a gas turbine or diesel engine (through an appropriate gearbox) which is part of a ground power unit (GPU) used to service Army helicopters.
- Loads:** All loads typically found in Army helicopters, particularly the AAH and UTTAS. In addition, loads in the GPU will include a battery charging TR and possibly a static converter rated at approximately 1 kva.
- Environment:**
- a) Unit must produce rated output when operating under any of the following conditions:
    - o Sea level to 10,000 ft
    - o -65°F to +140°F
    - o Humidity; sand and dust, or moisture as may be drawn into GPU enclosure
    - o Mounting in any attitude
  - b) In a nonoperating mode, unit will be subjected to shock and vibration loads as encountered during air or ground transport.
  - c) Unit shall be self-cooled.
- Rating:** Rating shall be in the range of 20 kva at 120/208 volts, three phase, 400 Hz. Power quality to meet MIL-STD-704A.
- Regulation & Protection:** Proposed system should include a GCU and regulator. GCU to include overvoltage, undervoltage, underfrequency, overcurrent, logic, anti-cycling, fault current limiting, contactor control and excitation control provisions. If special CTs are required, they shall be included. Regulator shall regulate voltage to MIL-STD-704A limits.
- Mounting Interface:** Preferred speed is 8,000 rpm but 12,000 or 6,000 are acceptable. Speed input range is ±5%. AND 10262, 5-inch bolt circle type mounting flange preferred. Direction of rotation is ccw facing mounting flange. Vendor to advise whether generator requires special cooling (oil or air) provisions and spline and flange details.

**Qualification:** Preference will be given to units that have previous military aircraft usage. Vendor to advise applicable specs and/or aircraft usage that applies to proposed hardware.

**Physical:** Vendor requested to advise and/or provide drawings on dimensions, weight, interfaces and mounting provisions for generator, GCU regulator and CTs.

**Vendor Response:** In addition to providing drawings in sufficient detail to design the GPU compartment, vendor is also requested to provide statement on repairability, maintainability, service life, maintenance man-hours per operating hour, MTBF and a description of the system. Vendor also requested to provide budgetary cost for 500-unit procurement over a three-year period based on 1976 prices.

## APPENDIX C

### PROBLEM STATEMENT

#### UNIT PERFORMANCE AND DESCRIPTION REQUIREMENTS

##### 60-HZ POWER SUPPLY

- Application:** To be mounted in a ground power unit (GPU) which is used to service Army helicopters.
- Loads:** Hand tools, trouble lights and miscellaneous housekeeping loads. Typical tools are a small hand drill, heat gun, soldering iron.
- Environment:**
- a) Unit must produce rated output when operating under any of the following conditions:
    - o Sea level to 10,000 ft
    - o -65°F to +140°F
    - o Humidity, sand and dust, or moisture as may be drawn into GPU enclosure
    - o Mounting in any attitude
  - b) In a nonoperating mode, unit will be subjected to shock and vibration loads as encountered during air or ground transport.
  - c) Unit shall be self-cooled.
- Noise:** Unit shall not emit acoustic noise or EMI that interferes with helicopter checkout.
- Rating:** Rating shall be approximately 1 kva but at least sufficient to permit satisfactory operation of loads indicated above.
- Input:** Preferred input is either single or three phase, 400 Hz, 120/208 volts, which will be within limits of MIL-STD-704A. Alternate inputs are full wave rectified 400 Hz or 28 vdc which is supplied by a transformer rectifier with an 11 a-hr battery floating on the bus.
- Output:** 60 Hz, 120 v, single phase. Wave shape and regulation to be adequate to permit satisfactory operation of loads indicated above.
- Protection:** Overload--others optional (ov, uv, etc.). Unit shall not be damaged by a short circuit.

**Qualification:** Preference will be given to units that have had previous aircraft application. Vendor is requested to list specs and/or aircraft usage that applies to proposed unit.

**Physical:** Vendor is requested to provide dimensions and weight of proposed unit. If two or more units are required to operate in parallel in order to adequately supply loads, size and weight of individual and total package shall be provided plus any interface devices or physical proximity limitations that apply.

**Vendor Response:** Interested vendors are requested to supply data on proposed inverter or converter to meet above problem statement. Key data required are size, weight, rating, output characteristics, input requirements, repairability, service life, MTBF, limitations (temperature, overload, vibration, power factor, etc.) and previous usage and qual status of proposed unit or its derivative. Vendor also to provide budgetary cost for 500-unit procurement over a three-year period based on 1976 pricing.

END  
5-79