

AD-A052 711

KANSAS UNIV/CENTER FOR RESEARCH INC LAWRENCE REMOTE --ETC F/G 17/9  
BACKSCATTER PROPERTIES OF SEA ICE WITH RADAR. ARCTIC OPERATIONS--ETC(U)  
OCT 77 R G ONSTOTT, G J DOME, R A HAND N00014-76-C-1105

UNCLASSIFIED

RSL-TM-331-1

NL

1 OF 2  
AD  
A052 711



1

AD-A052711



DDC  
REF ID: A052711  
APR 14 1978  
D



THE UNIVERSITY OF KANSAS CENTER FOR RESEARCH, INC.  
2291 Irving Hill Drive—Campus West  
Lawrence, Kansas 66045

**DISTRIBUTION STATEMENT A**  
Approved for public release;  
Distribution Unlimited



**THE UNIVERSITY OF KANSAS SPACE TECHNOLOGY CENTER**  
**Raymond Nichols Hall**

2291 Irving Hill Drive—Campus West Lawrence, Kansas 66045

Telephone:



**BACKSCATTER PROPERTIES OF SEA ICE  
WITH RADAR**

**ARCTIC OPERATIONS DESCRIPTION AND  
PRELIMINARY DATA SUMMARY**

R.G. Onstott, Project Engineer  
G.J. Dome  
R.A. Hand  
J. Hague  
H. Pape  
Richard K. Moore, Principal Investigator

Remote Sensing Laboratory  
Center for Research, Inc.  
The University of Kansas  
Lawrence, Kansas 66045

RSL Technical Memorandum  
RSL TM 331-1

October 1977

Supported by:

OFFICE OF NAVAL RESEARCH  
Department of the Navy  
800 N. Quincy Street  
Arlington, Virginia 22217

CONTRACT N00014-76-C-1105

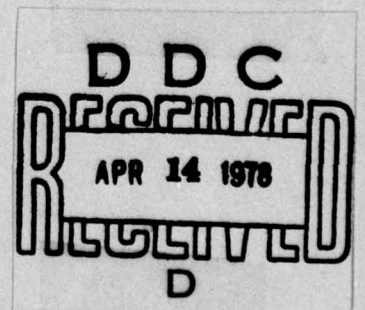

CRES



**DISTRIBUTION STATEMENT A**

Approved for public release;  
Distribution Unlimited

REMOTE SENSING LABORATORY

REPORT DOCUMENTATION PAGE		READ INSTRUCTIONS BEFORE COMPLETING FORM
1. REPORT NUMBER	2. GOVT ACCESSION NO.	3. RECIPIENT'S CATALOG NUMBER
4. TITLE (and Subtitle)  Backscatter Properties of Sea Ice with Radar Arctic Operations Description and Preliminary Data Summary		5. TYPE OF REPORT & PERIOD COVERED
		6. PERFORMING ORG. REPORT NUMBER
7. AUTHOR(s) R.G. Onstott, G.J. Dome, R.A. Hand, J. Hague, H. Pape, and R.K. Moore		8. CONTRACT OR GRANT NUMBER(s)
9. PERFORMING ORGANIZATION NAME AND ADDRESS		10. PROGRAM ELEMENT, PROJECT, TASK AREA & WORK UNIT NUMBERS
11. CONTROLLING OFFICE NAME AND ADDRESS		12. REPORT DATE
		13. NUMBER OF PAGES
14. MONITORING AGENCY NAME & ADDRESS (if different from Controlling Office)		15. SECURITY CLASS. (of this report)
		15a. DECLASSIFICATION/DOWNGRADING SCHEDULE
16. DISTRIBUTION STATEMENT (of this Report)		
<div style="border: 1px solid black; padding: 5px; width: fit-content; margin: 0 auto;"> <p><b>DISTRIBUTION STATEMENT A</b> Approved for public release; Distribution Unlimited</p> </div>		
17. DISTRIBUTION STATEMENT (of the abstract entered in Block 20, if different from Report)		
18. SUPPLEMENTARY NOTES		
19. KEY WORDS (Continue on reverse side if necessary and identify by block number)		
20. ABSTRACT (Continue on reverse side if necessary and identify by block number)		
<p>Active microwave responses of sea ice and lake ice were investigated at sites located off the North Alaskan Coast in the Arctic Ocean. The experimenters were ground-based at the Naval Arctic Research Laboratory, NARL, located outside of Barrow, Alaska, during May 1977, an early spring month in the Arctic. Microwave equipment was mounted on a portable A-frame type support system which was transported to test sites via sled and snowmobile and assembled. Data were acquired at numerous microwave</p>		

20. frequencies, receive-transmit polarizations, and angles of incidence for 5 sea ice and 2 lake ice types. This memo documents the experiment and the experimental procedure; and lists the raw experimental data.

ACCESSION BY	
NTIS	White Section <input checked="" type="checkbox"/>
DDI	Buff Section <input type="checkbox"/>
UNANNOUNCED	<input type="checkbox"/>
JUSTIFICATION	
Per Hq. on file	
BY	
DISTRIBUTION/AVAILABILITY CODES	
Dist.	AVAIL. and/or SPECIAL
A	

DISTRIBUTION STATEMENT A  
 Approved for public release;  
 Distribution Unlimited

## TABLE OF CONTENTS

	<u>Page</u>
ACKNOWLEDGEMENT	i
ABSTRACT	ii
1.0 INTRODUCTION	1
2.0 EXPERIMENT DESCRIPTION	3
2.1 SITE DESCRIPTION	3
2.2 MICROWAVE SENSOR - MAS JR. 1-2 AND 8-18	3
2.3 GROUND TRUTH	8
2.3.1 Snow Conditions	8
2.3.1.1 Snow Depth	8
2.3.1.2 Snow Density	8
2.3.1.3 Snow Temperature	9
2.3.1.4 Snow Wetness	9
2.3.1.5 Surface Roughness	9
2.3.2 Ice Conditions	9
2.3.2.1 Ice Type	9
2.3.2.1 Ice Thickness	10
2.3.2.3 Surface Roughness	10
2.3.2.4 Horizontal Inhomogeneity	10
2.3.2.5 Temperature Profile	10
2.3.2.6 Stratification	10
2.3.2.7 Salinity Profiles	13
2.3.3 Air Temperature	13
2.4 DATA ACQUISITION	13
2.4.1 Logistics	13
2.4.2 Backscatter Measurements	14
2.4.3 Experimental Procedure	16
3.0 SUMMARY	21
APPENDIX A. SITE SUMMARY	22
APPENDIX B. RAW L-BAND DATA	23
APPENDIX C. RAW Ku-X-BAND DATA	30
APPENDIX D. GROUND TRUTH NOTES	97
PART I	98
PART II	112

TABLE OF CONTENTS (continued)

	<u>Page</u>
APPENDIX E. SALINITY MEASUREMENTS	129
APPENDIX F. THIN SECTION LOCATION LOG	137
APPENDIX G. GROUND TRUTH PHOTO LOG FOR CORES AND THIN SECTIONS	139
APPENDIX H. ASSEMBLY INSTRUCTIONS	146

## LIST OF FIGURES

	<u>Page</u>
FIGURE 1. MAS JR. IN OPERATION	4
FIGURE 2. DETAIL OF L-BAND ANTENNAS AND HARDWARE ARRANGEMENT	4
FIGURE 3. DETAIL OF KU-X-BAND HARDWARE AND ANTENNAS	5
FIGURE 4. DETAIL OF KU-X-BAND ANTENNA AND REFLECTOR ARRANGEMENT	5
FIGURE 5. MAS JR. SYSTEM BLOCK DIAGRAM	7
FIGURE 6. COVING AND DRILLING TO DETERMINE ICE THICKNESS	11
FIGURE 7. MICROTONE IN OPERATION	11
FIGURE 8. THIN-SECTION ON MICROTONE	12
FIGURE 9. SOFT LIGHT SOURCE WITH POLARIZING FILTER	12
FIGURE 10a. EXAMPLE OF ILLUMINATED THIN SECTION	15
FIGURE 10b. EXAMPLE OF ILLUMINATED THIN SECTION AS VIEWED WITH POLARIZING FILTER	15
FIGURE 11. AN APPLIED POSITIONING SCHEME USED TO OBTAIN MULTIPLE LOOK POSITIONS	17
FIGURE 12. SYSTEM CONFIGURATION	18

LIST OF TABLES

	<u>Page</u>
TABLE 1. SITE SUMMARY	2
TABLE 2. NOMINAL SYSTEM SPECIFICATIONS	6
TABLE 3. NOMINAL TIMES FOR DATA ACQUISITION	14
TABLE 4. TARGET RETURN VERSUS BACKGROUND RETURN	20

## ACKNOWLEDGEMENT

We wish to acknowledge the technical and logistic assistance; the fine meals; and comfortable accommodations of the Naval Arctic Research Laboratory.

We wish especially to acknowledge Dr. W.F. Weeks, CRREL, for his ground truth efforts in the experiment.

We would like to acknowledge Professors F.T. Ulaby and K.C. Carver for their suggestions and help throughout the developmental stages of MAS Jr.

Mr. James Hague, a NESEP student, put in many long hours for "problem-course" credit, somewhat to the detriment of his studies, because of his sense of responsibility to this project. These efforts are greatly appreciated.

## ABSTRACT

Active microwave responses of sea ice and lake ice were investigated at sites located off the North Alaskan Coast in the Arctic Ocean. The experimenters were ground-based at the Naval Arctic Research Laboratory, NARL, located outside of Barrow, Alaska, during May 1977, an early spring month in the Arctic. Microwave equipment was mounted on a portable A-frame type support system which was transported to test sites via sled and snowmobile and assembled. Data were acquired at numerous microwave frequencies, receive-transmit polarizations, and angles of incidence for 5 sea ice and 2 lake ice types. This memo documents the experiment and the experimental procedure; and lists the raw experimental data.

## 1.0 INTRODUCTION

The use of radar imagers to monitor the properties of sea ice has been tested in numerous experiments in recent years. The actual properties of the radar return from sea ice of known characteristics are still known only in a qualitative way. The ice cover in the Arctic Ocean and associated areas is of great importance to potential naval operations both on the surface and below it. Civilian needs call for an understanding of the properties of the ice due to development of the oil reserves of the Alaskan and Canadian North Coasts and off-shore areas.

The uncertainties that have accompanied previous experiments provided the impetus to perform this experiment. To develop a quantitative understanding of the radar backscatter properties of sea ice, a ground-based 8-18 GHz scatterometer-spectrometer and a SEASAT-SAR-frequency scatterometer (1-26 Hz) were designed and constructed. The multiple frequencies, numerous polarizations, angles of incidence from 10 to 70 degrees, and ground truth provide a complete story of the backscatter properties over the frequency range of interest.

In the Arctic spring of 1977, the portable "Microwave Active Spectrometer (MAS Jr:)" was used to collect data investigating the backscatter properties of sea ice off the North Alaskan Coast. Inland lake ice was also easy to access. Backscatter measurements and ground truth were taken to complement the sea ice study. Table 1 summarizes the categories of ice, dates the backscatter investigations were performed, and the number of looks at a site.

TABLE 1. SITE SUMMARY

SITE NUMBER	CATEGORY	DATES INVESTIGATION PERFORMED	NUMBER OF LOOKS
1	Thick first year	5/14/77 to 5/15/77	5
2	Multi-year	5/17/77 to 5/18/77	6
3	Thick first year	5/19/77 to 5/21/77	6
4	Small pressure ridge	5/21/77 to 5/22/77	2
5	Multi-year	5/22/77 to 5/23/77	6
6	Lake ice*	5/25/77 to 5/26/77	5
7	Lake ice**	5/28/77	3

\*Lake ice with sea ice substructure

\*\*Lake ice frozen to bottom

## 2.0 EXPERIMENT DESCRIPTION

The following section describes the test site, the equipment, the ground truth, and the data acquisition.

### 2.1 SITE DESCRIPTION

The test sites were selected on the basis of site logistic simplicity and availability of cooperative programs by other investigators. It was initially proposed to perform the investigation using Narwhal Island as ground-base. Narwhal Island, an ice covered gravel bar, is located at Prudhoe Bay in the McClure Islands. Ice conditions for the season were abnormal with formations of multi-year and thick first-year ice nearly non-existent in the area. The logistic plan was to transport men and system to ice sites via helicopter. Sites would have been several hundred kilometers away, making experiments dangerous and extremely time-consuming, requiring more helicopter time than was available. Discussions proceeded to locate a more advantageous ground-base. NARL was chosen after an aerial survey located numerous ice categories off its coast. The Naval Arctic Research Laboratory provided site logistic simplicity, a comfortable ground base, lab facilities, and availability of cooperative investigators. NARL is situated along the North Alaskan Coast of the Arctic Ocean near Point Barrow.

Shorefast ice extended outward into the Arctic Ocean for several thousand meters. Ice categories such as multi-year, thick first-year, lagoon, pressure ridges, and stacks were located in the shorefast ice. Inland ice sites within reach included lakes with scientifically interesting ice structures.

### 2.2 MICROWAVE SENSOR - MAS JR. 1-2 AND 8-18

MAS Jr. is a portable ground-based wideband FM-CW radar. Figure 1 shows the radar and structure in operation. Figure 2 shows detail of the L-band (1-2 GHz) antenna and hardware arrangement. Figures 3 and 4 show the Ku-X-band (8-18 GHz) antennas, hardware, and reflector arrangement. Nominal system specifications for MAS Jr. are given in Table 2. A system block diagram is shown in Figure 5.

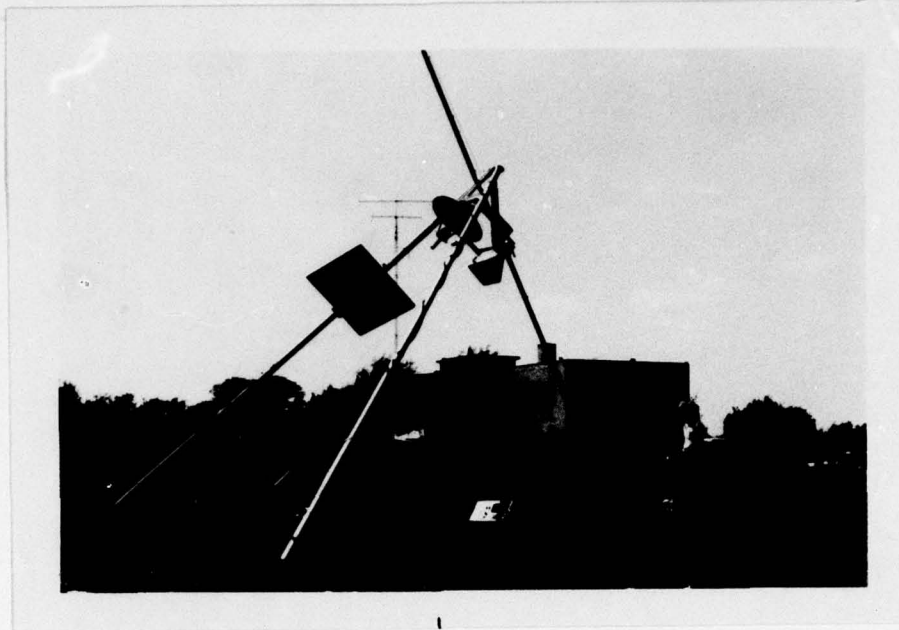

Figure 1. MAS Jr. in Operation

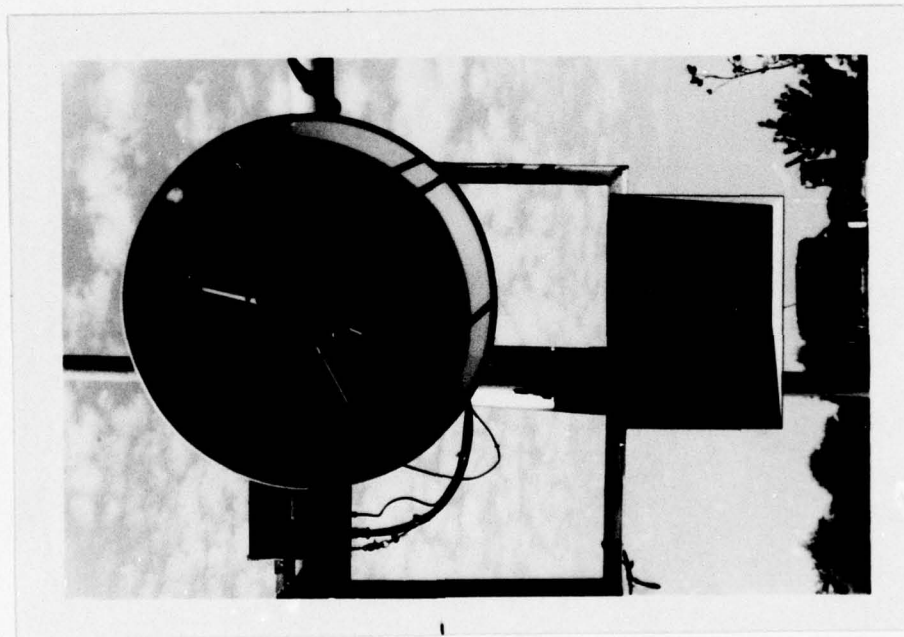

Figure 2. Detail of L-band Antenna and Hardware Arrangement.

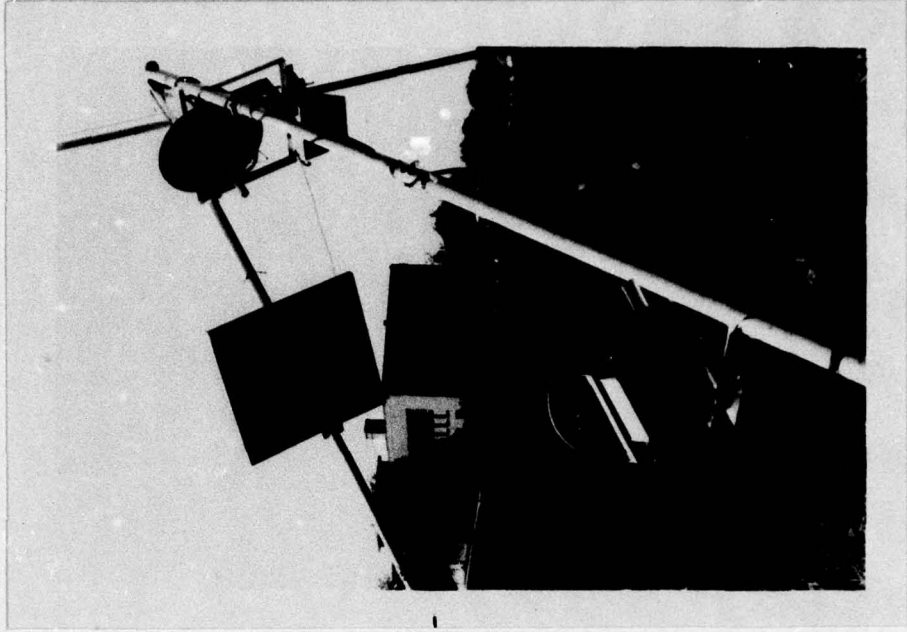

Figure 4. Ku-X-band Antenna and Reflector Arrangement Detail

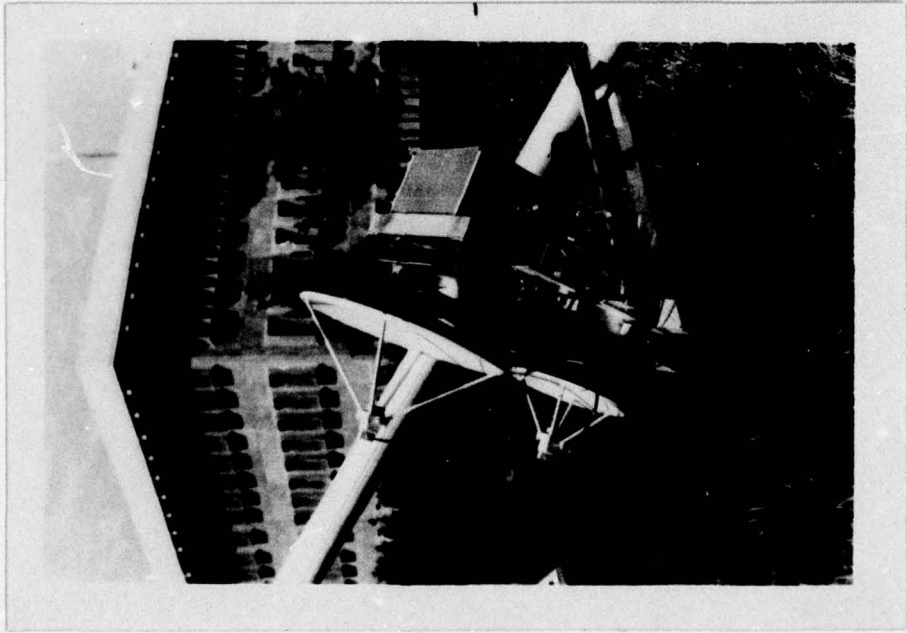

Figure 3. Detail of Ku-X-band Hardware and Antennas

TABLE 2. NOMINAL SYSTEM SPECIFICATIONS

	<u>Ku-X-band</u>	<u>L-band</u>
Type	FM-CW	FM-CW
Frequency Range	8-18 GHz	1.5 GHz
Modulating Waveform	Triangular	Triangular
FM Sweep: $\Delta f$	1 GHz	800 MHz
Transmitter Power	14-19 <b>mW</b>	50 mW
Intermediate Frequency	50 kHz	50 kHz
IF Bandwidth	10 kHz	10 kHz
<b>Antennas</b>		
Receive Type	46 cm. Reflector	91 cm. Reflector
Transmit Type	31 cm. Reflector	Standard Gain Horn
Feeds	Dual Ridge Horn	Log Periodic
Polarization Capabilities	HH,HV,VV,VH	VV,VH
Target Distance	10.7 meters	6.1 meters
Transmit Beamwidth	8.2° at 8 GHz 4.0° at 17.7 GHz	27°
Receive Beamwidth	5.3° at 8 GHz 2.3° at 17.8 GHz	9.5°
Incidence Angle Range	10° - 70°	10° - 70°
<b>Calibration:</b>		
Internal	Signal Injection (delay line)	Signal Injection (shorted delay line)
External	Luneberg Sphere Reflector	Square Trihedral Corner Reflector
Operating Temperature Range	-50° C to +50° C	-50° C to +50° C

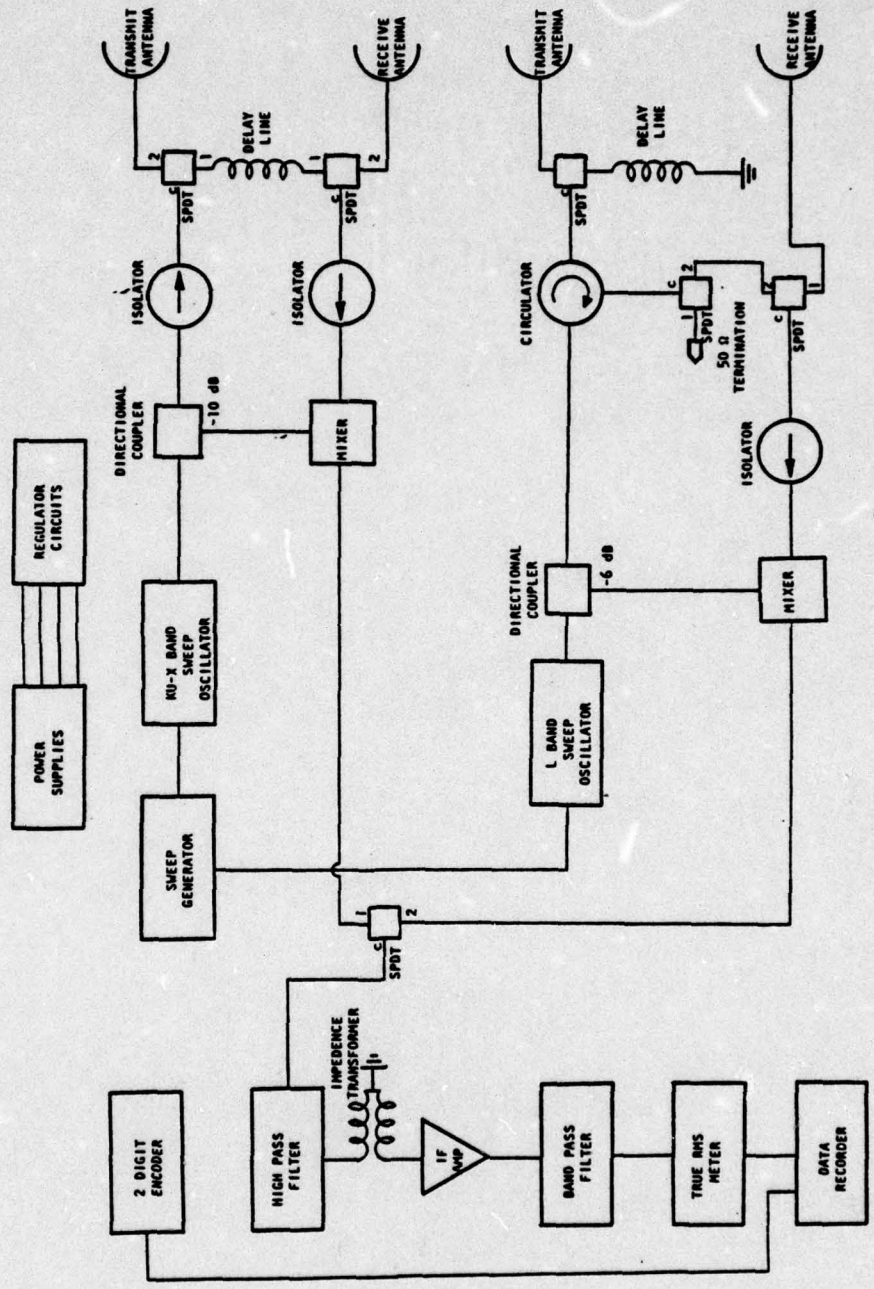

Figure 5. Block Diagram of MAS Jr. System.

## 2.3 GROUND TRUTH

This section covers description of the sampling techniques used to describe snow and ice conditions.

### 2.3.1 Snow Conditions

The following parameters were measured for the snowpack:

- (1) Depth
- (2) Density
- (3) Temperature
- (4) General description of grain size, shape, and texture
- (5) Surface roughness

#### 2.3.1.1 Snow Depth

Snow depth was measured at the center of the area illuminated by the Ku-X-band radar. The L-band radar spot was within one and a half meters. Depth was taken using a meter rule as the gauge.

#### 2.3.1.2 Snow Density

Snow density was measured using a horizontal sampling technique. A thin-walled aluminum cylinder of known volume and weight was implanted into the snow horizontally. After carefully removing the cylinder by brushing the snow away and shaving the snow off the ends, the known volume of snow and cylinder were weighed. Data were recorded relating the snow density and the horizontal axis of the cylinder above the ice surface. When the snow was several centimeters in depth, samples were taken to provide a density profile.

#### 2.3.1.3 Snow Temperature

Snow temperatures were measured in the first few centimeters below the air-snow interface. Snow depths were usually limited to a few centimeters such that a profile measurement was not needed. Temperatures were measured using a Fastemp portable temperature meter and a surface probe.

#### 2.3.1.4 Snow Wetness

Snow wetness experiments were not performed. Air temperatures were expected to be low with low snow temperatures, thus suppressing free water in the thin snowpack.

#### 2.3.1.5 Surface Roughness

Surface roughness was recorded by photographs of a grid inserted into the snowpack. The grid lines were spaced at 2 centimeter intervals.

#### 2.3.2 Ice Conditions

The following parameters were measured:

- (1) Type
- (2) Thickness
- (3) Surface roughness
- (4) Horizontal inhomogeneity
- (5) Temperature profile
- (6) Salinity profile

##### 2.3.2.1 Ice Type

The ice was categorized by visual inspection. Dr. W.F. Weeks of the U.S. Army Cold Regions Research and Engineering Laboratory provided the expertise here and throughout all ground-truth phases.

#### 2.3.2.2 Ice Thickness

Ice thickness was determined by coring with a small-diameter coring tool and then measuring depth using a line, sinker, and rule device.

#### 2.3.2.3 Surface Roughness

Surface roughness was described as to how the surface rolled, sloped, and had bumps. Small scale characteristics in the first few centimeters were observed.

#### 2.3.2.4 Horizontal Inhomogeneity

Cores were typically taken at each look position. Less-than-millimeter thickness slices were taken out of the core using a microtone (Figures 7 and 8). The microtone shaved sections of ice to obtain the millimeter thickness. To examine a "thin section" of the ice core, an enclosed soft light source was used (Figure 9). Black-and-white photographs using a macro lens were taken of the eight-millimeter-diameter thin sections. See Figure 10 for an example.

Cores were stored, thin sections cut, and photographs made in a cold storage shed. Storage temperature was typically  $-5^{\circ}$  F.

#### 2.3.2.5 Temperature Profile

A temperature profile was measured at intervals of a few centimeters in the ice core by drilling small diameter holes into the core using a hand drill and inserting probe-type thermometers. The temperature of the probe was allowed to stabilize before recording.

#### 2.3.2.6 Stratification

Stratification was logged by recording visual impressions and by photographs. A macro lens was used. All cores were photographed as complete cores, in 30 centimeter lengths, and close ups of small sections of interest.



Figure 6. Coring and Drilling to Determine Ice Thickness



Figure 7. Microtone in Operation

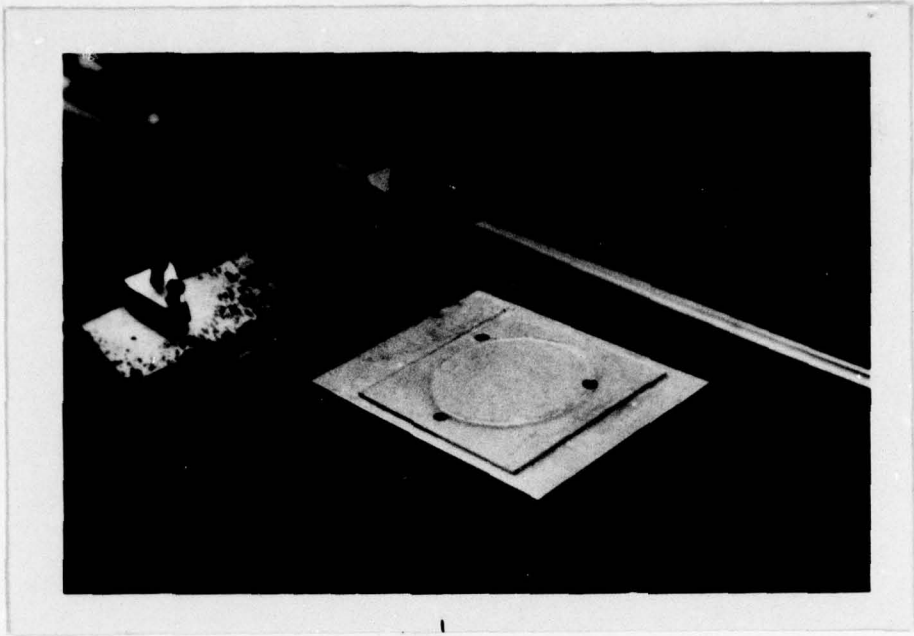

Figure 8. Thin Section on Microtome



Figure 9. Soft Light Source with Polarizing Filter

### 2.3.2.7 Salinity Profiles

A core to be used for the salinity profile was obtained at each site. The core was sectioned into 10-centimeter lengths with a saw and placed into quart plastic containers. These containers were enclosed with their mating cover, taken to the laboratory, and allowed to melt at room temperature. A salinity bridge was used to make measurements of the sea ice melt samples.

A more sophisticated salinity meter was used to make measurements of the low-salinity lake ice melt samples.

### 2.3.3 Air Temperature

Air temperature was recorded at each look position. The Fastemp thermometer and air probe was used.

## 2.4 DATA ACQUISITION

This section describes the specifics of the data acquisition process of the performed radar backscatter experiment.

### 2.4.1 Logistics

MAS Jr. may be considered to consist of the following subpackages:

- (1) A-frame antenna support system
- (2) Ku-X-band microwave hardware and dual antenna assembly
- (3) L-band microwave hardware module
- (4) L-band 3' parabolic dish and L-band horn
- (5) Power and data acquisition control unit
- (6) Power system (900 VA generator, 12 volt storage battery, battery charger)
- (7) Calibration targets with known radar cross sections
- (8) Miscellaneous tools and hardware

All of the above gear was transported to selected sites off the coast near NARL. A snowmobile and 12-foot sled provided the means of transportation of all logistic movements of man and system. The power and data-acquisition

control unit, generator, storage battery, and charger were transported back to NARL at the end of each day. The remainder was left at the ice sites.

Ice sites were selected by Dr. Weeks from both ground and air visual inspection of the off-shore coastal area near NARL. Representative samples of the available types of sea ice and lake ice which were accessible by snowmobile were selected.

#### 2.4.2 Backscatter Measurements

Measurements were made at 10 frequencies, up to 4 transmit-receive configurations, and 7 angles of incidence from  $10^{\circ}$  to  $70^{\circ}$  at each look position. Up to 6 look positions were taken at a site to employ spatial averaging in the reduction of the effects of fading. The number of looks at a site was limited by time factors. Normally two days were allowed per site. Nominal times for performance of a site experiment may be found in Table 3.

TABLE 3  
NOMINAL TIMES FOR DATA ACQUISITION\*

Function	Time (Minutes)
Complete Assembly	75
Data Set - 1 Look	60
Reposition - New Look	30 to 60
Disassembly	45
Loading Sleds	30

\*Three man operation

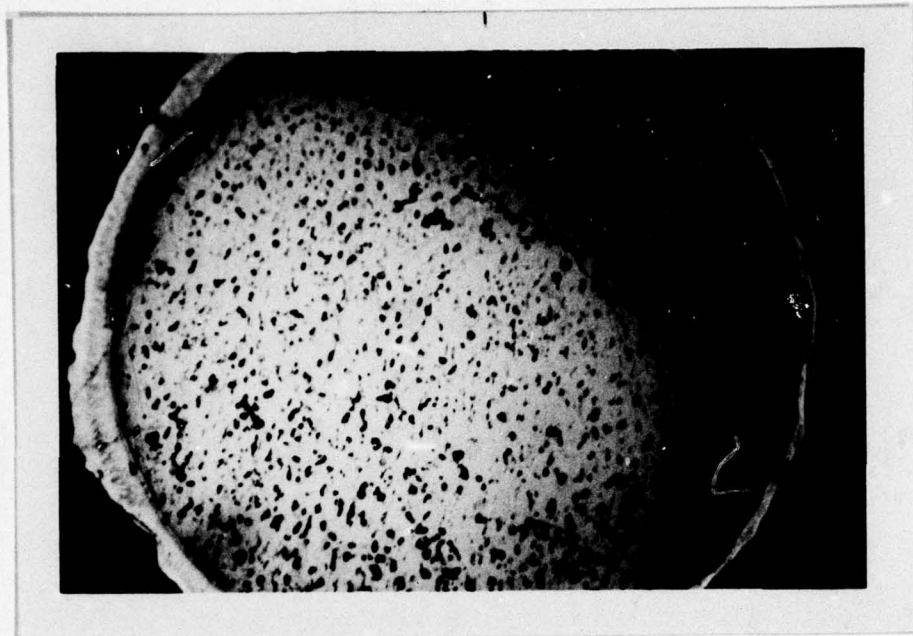

Figure 10a. Example of Illuminated Thin Section

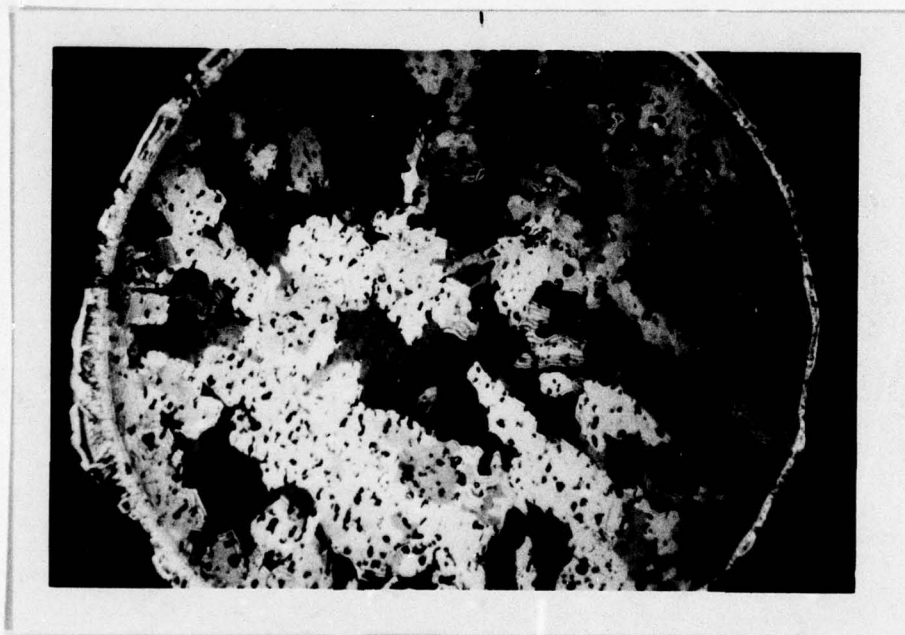

Figure 10b. Example of Illuminated Thin Section as Viewed with Polarizing Filter

Independent look positions were obtained by physically repositioning the scatterometer so that at least half of the new illuminated cell was not overlapped by a previous cell. Figure 11 demonstrates one scheme used to reposition the scatterometer. This was commonly used where a large area of smooth ice was observed.

#### 2.4.3 Experimental Procedure

The system was assembled, using the "assembly instructions" found in the Appendix as a guide. The reflector was aligned using the attached cable straps. Ku-X-band antenna alignment was checked using a four-power rifle scope which could be positioned on each antenna. Alignment of the antennas remained stable throughout shipping and all phases of the experiment. L-band antennas required no additional alignment through the experimental phase.

The scatterometer was configured as shown in Figure 12. The winch ran from a large-capacity 12-volt storage battery. Due to continuous use throughout the day and due to the cold operating conditions, a 12-ampere charger charged the battery continuously. It also acted as an additional 12-ampere 12-volt source. The winch typically drew 20 amperes.

Power-up and system stabilization proceeded as follows. After major assembly was completed, the generator was activated, charging the battery and charging the power control and data acquisition center. As soon as the antennas were in place with microwave ports connected, the microwave hardware was energized. The L-band and Ku-X-band hardware may be energized independently by each having their own control cable. When both cables are linked, both L-band and Ku-X-band microwave hardware modules are in transmit-receiver mode, or one in transmit-receive and the other in delay-line-calibrate mode. Each microwave system was allowed a warm up period. Data acquisition proceeded when returns from the delay-line-calibration mode stabilized.

Data were typically taken using the following format:

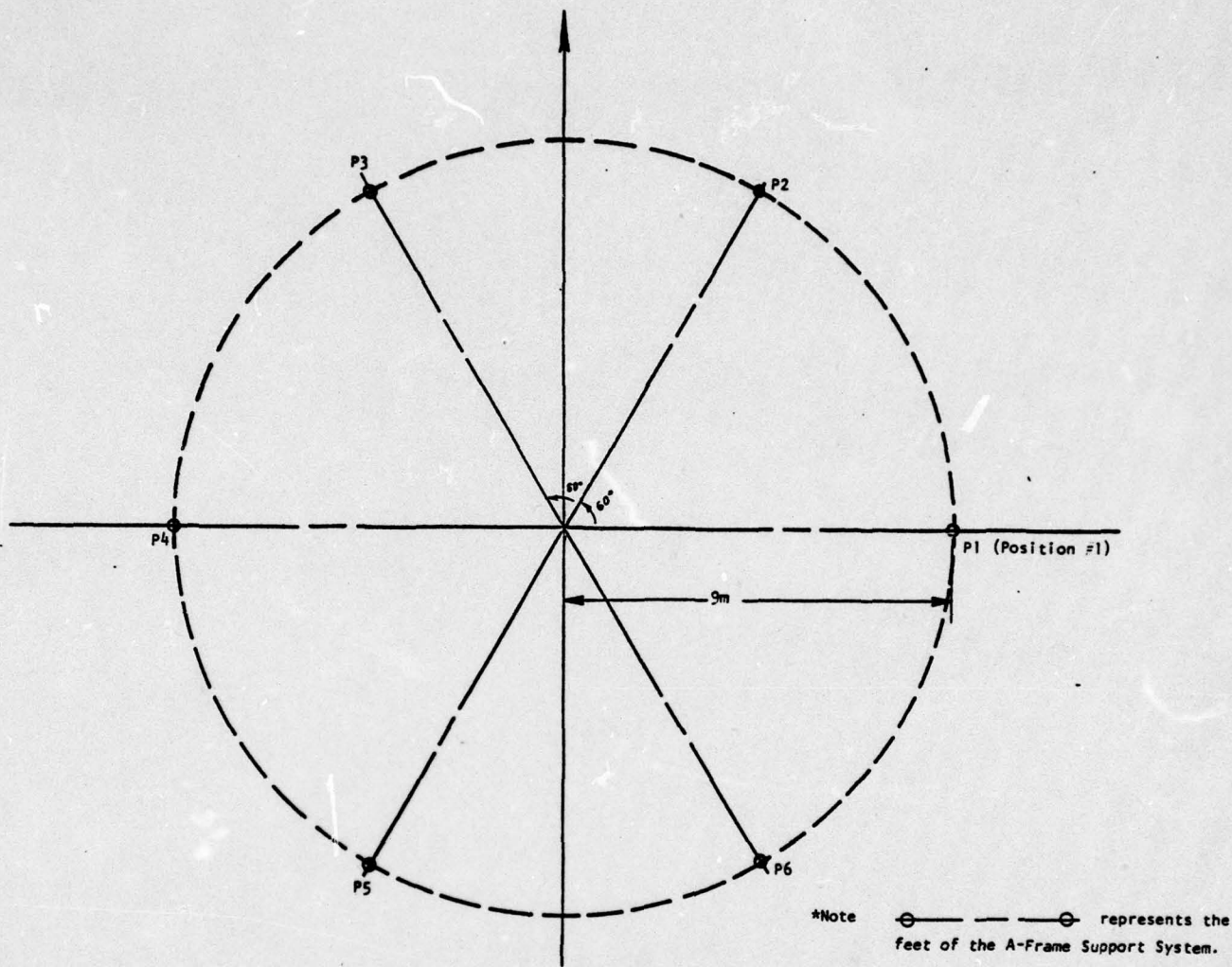
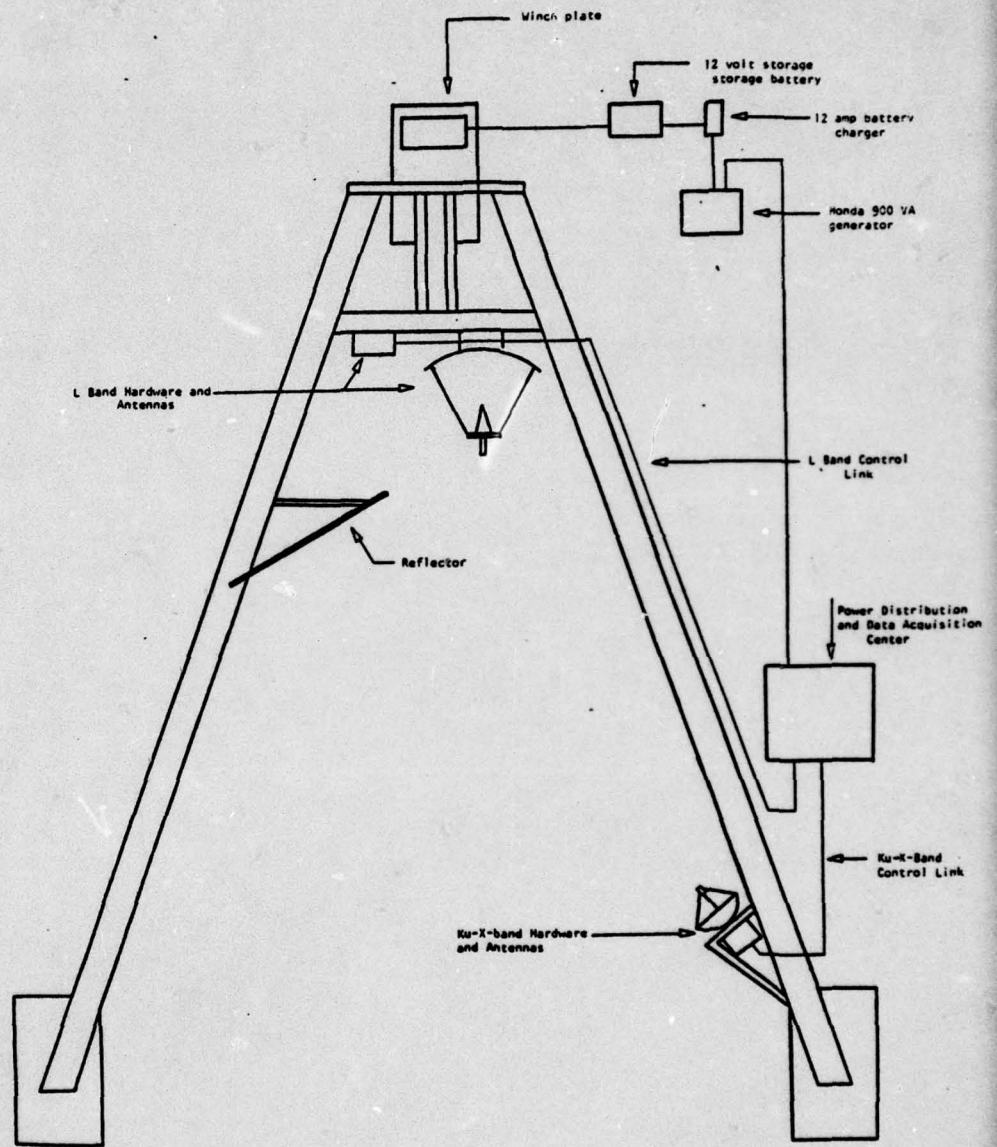

Figure 11. An Applied Positioning Scheme Used to Obtain Multiple Look Positions



System Configuration

Figure 12

- (1) L-band delay line return.
- (2) Nine frequencies of Ku-X-band delay line returns.
- (3) L-band VV and Ku-X-band HH returns for 10 frequencies at  $20^{\circ}$  off horizontal.
- (4) Proceeded up to  $10^{\circ}$  off nadir taking data at each preset angle of incidence.
- (5) At  $10^{\circ}$  off nadir, changed to Ku-X-band HV and took 9 frequencies of Ku-X-band, then coming down for all established angles of incidence.
- (6) At  $20^{\circ}$  off horizontal the L-band dish was rotated for VH. Ku-X-band antennas were rotated for VV. Data taking proceeded as in Step 4.
- (7) At  $10^{\circ}$  off nadir Ku-X-band receive antenna was rotated for VH and the data taking cycle continued.

The returns were recorded using a 6-digit-with-sign formatted thermal printer and paper tape. After the data set was completed, partial dis-assembly was undertaken and the structure moved to the new look position. The old look position then became active with ground-truth data gathering. A core was taken for salinity measurements and one taken for stratification and thin section study. Temperature profiles, snow data, and surface data were taken.

Calibration with targets of known radar cross-sections were made at each site. A Luneberg lens was used for the Ku X-band radar and a square trihedral corner reflector was used for the L-band radar. The targets were positioned on the ice in the main beams of the radar for maximum return. Included here is an example of the power returns of the targets versus the return from an ice background. This comparison is from site 5 look 6.

TABLE 4  
 TARGET RETURN VERSUS BACKGROUND RETURN

Frequency - GHz	VV Background (dB)	VV Target (dB)	Target/ Background (dB)
1.5	-17.0	+5.2	+22.2
9.0	-21.6	- .3	+21.3
12.0	-20.9	+ .0	+20.9
17.0	-35.2	-15.2	+20.1

The above table shows that lens and trihedral returns were significantly larger (> 20 dB) than ice returns; thus calibration returns may be considered independent of background.

### 3.0 SUMMARY

Available types of ice were investigated during the 4-week experiment. The experiment was terminated due to the warming weather conditions. Seven sites and five categories of ice were investigated. Thirty-three look positions were obtained. The raw data and ground-truth are given in the Appendix.

Apparent consistent differences between L-band return for different looks appear for Sites 1 and 3 (smooth first-year ice). Explanation must await further analysis of the ground-truth information.

Analysis of the observations had just started at the time of preparation of this report. Detailed correlation of ground-truth and radar data will be presented in a subsequent report. The L-band raw data presented in the Appendix will be subject to modification when a procedure is implemented to compensate for effects of the wide beam on measurements of angular variation.

APPENDIX A.

TABLE 1. SITE SUMMARY

SITE NUMBER	CATEGORY	DATES INVESTIGATION PERFORMED	NUMBER OF LOOKS
1	Thick first year	5/14/77 to 5/15/77	5
2	Multi-year	5/17/77 to 5/18/77	6
3	Thick first year	5/19/77 to 5/21/77	6
4	Small pressure ridge	5/21/77 to 5/22/77	2
5	Multi-year	5/22/77 to 5/23/77	6
6	Lake ice*	5/25/77 to 5/26/77	5
-7	Lake ice**	5/28/77	3

\*Lake ice with sea ice substructure

\*\*Lake ice frozen to bottom

APPENDIX B. RAW L-BAND DATA

Raw L-band data is included here. Data are listed according to date of experiment, site number, and look number. The angle of incidence of the return is indicated at the top of the first heading page. The transmit-receive configurations are indicated by VV and VH shown to the left of the data. Lens return with the corresponding delay line return are indicated as LENS and DLL. The first DLT is the delay line return taken prior to beginning a data run. The second DLT is the delay line return taken at the end of a data run.

## SEA ICE DATA      SPRING 1977 EXPERIMENT

## L-BAND DATA

ANGLE	10	20	30	40	50	60	70
-------	----	----	----	----	----	----	----

DATE- MAY 14, 1977      SITE- 1    LOOK- 1

VV	LENS-	-6.88	DLL-	21.76	DLT-	21.76	DLT-	21.76
		-28.28		-30.45		-28.44		-30.07
				-27.27		-15.70		-14.44
VH	LENS-	-6.88	DLL-	21.76	DLT-	21.76	DLT-	21.76
		-32.49		-29.92		-32.54		-30.69
				-29.35		-30.17		-26.79

DATE- MAY 14, 1977      SITE- 1    LOOK- 2

VV	LENS-	-6.88	DLL-	21.76	DLT-	17.43	DLT-	20.06
		-33.56		-33.31		-31.16		-30.89
				-29.42		-14.81		-30.01
VH	LENS-	-6.88	DLL-	21.76	DLT-	22.69	DLT-	22.69
		-32.45		-31.51		-33.04		-31.66
				-31.40		-28.97		-27.30

DATE- MAY 14, 1977      SITE- 1    LOOK- 3

VV	LENS-	-6.88	DLL-	21.76	DLT-	21.74	DLT-	19.62
		-18.21		-16.77		-15.82		-15.33
				-13.64		-11.28		-10.84
VH	LENS-	-6.88	DLL-	21.76	DLT-	21.74	DLT-	21.74
		-29.73		-31.65		-31.62		-29.49
				-29.08		-29.07		-29.22

DATE- MAY 15, 1977      SITE- 1    LOOK- 4

VV	LENS-	-7.47	DLL-	23.17	DLT-	23.17	DLT-	23.07
		-18.59		-18.42		-17.36		-16.96
				-16.48		-14.87		-15.77
VH	LENS-	-7.47	DLL-	23.17	DLT-	22.97	DLT-	22.97
		-24.04		-22.72		-24.51		-21.71
				-22.51		-21.11		-21.98

DATE- MAY 15, 1977      SITE- 1    LOOK- 5

VV	LENS-	-7.47	DLL-	23.17	DLT-	23.91	DLT-	23.40
		-16.36		-16.62		-16.83		-17.95
				-17.70		-17.09		-10.55
VH	LENS-	-7.47	DLL-	23.17	DLT-	22.38	DLT-	22.88
		-22.83		-22.12		-23.31		-22.75
				-22.47		-24.11		-16.88

24

DATE- MAY 17, 1977 SITE- 2 LOOK- 1

VV	LENS-	-2.34	DLL-	16.86	DLT-	24.46	DLT-	22.56
		-23.83	-21.03	-20.30	-19.57	-17.44	-15.45	-15.27
VH	LENS-	-2.34	DLL-	16.86	DLT-	20.66	DLT-	18.76
		-25.82	-23.19	-22.72	-20.85	-23.05	-19.46	-16.46

DATE- MAY 17, 1977 SITE- 2 LOOK- 2

VV	LENS-	-2.34	DLL-	16.86	DLT-	22.01	DLT-	22.01
		-20.08	-21.77	-19.22	-17.84	-19.99	-15.13	-6.21
VH	LENS-	-2.34	DLL-	16.86	DLT-	22.01	DLT-	22.01
		0.	0.	0.	0.	0.	0.	0.

DATE- MAY 17, 1977 SITE- 2 LOOK- 3

VV	LENS-	-2.34	DLL-	16.86	DLT-	21.01	DLT-	21.01
		-21.00	-18.80	-17.78	-17.26	-14.72	-13.31	-7.65
VH	LENS-	-2.34	DLL-	16.86	DLT-	21.01	DLT-	21.01
		-22.49	-22.09	-21.42	-21.45	-20.20	-15.59	-12.13

DATE- MAY 18, 1977 SITE- 2 LOOK- 4

VV	LENS-	-2.34	DLL-	16.86	DLT-	24.74	DLT-	24.56
		-22.27	-19.64	-17.61	-18.14	-17.48	-18.41	-8.59
VH	LENS-	-2.34	DLL-	16.86	DLT-	24.56	DLT-	24.56
		-24.24	-21.65	-21.31	-23.02	-23.45	-17.08	-11.11

DATE- MAY 18, 1977 SITE- 2 LOOK- 5

VV	LENS-	-2.34	DLL-	16.86	DLT-	23.96	DLT-	23.96
		-22.85	-20.65	-20.03	-19.10	-19.09	-17.93	-17.64
VH	LENS-	-2.34	DLL-	16.86	DLT-	23.96	DLT-	23.96
		-24.83	-23.38	-23.07	-21.47	-20.72	-18.91	-18.51

DATE- MAY 18, 1977 SITE- 2 LOOK- 6

VV	LENS-	-2.34	DLL-	16.86	DLT-	23.21	DLT-	23.21
		-18.44	-18.32	-17.63	-16.71	-14.08	-10.54	-7.48
VH	LENS-	-2.34	DLL-	16.86	DLT-	0.	DLT-	0.
		0.	0.	0.	0.	0.	0.	0.

25

DATE- MAY 19, 1977 SITE- 3 LOOK- 1

VV	LENS-	-1.82	DLL-	20.65	DLT-	21.38	DLT-	21.20
		-21.30	-21.00	-20.14	-22.39	-21.74	-21.54	-15.00
VH	LENS-	-1.82	DLL-	20.65	DLT-	21.02	DLT-	20.83
		-24.28	-25.28	-22.89	-24.23	-24.59	-22.42	-16.68

DATE- MAY 19, 1977 SITE- 3 LOOK- 2

VV	LENS-	-1.82	DLL-	20.65	DLT-	20.12	DLT-	20.35
		-23.58	-21.78	-23.35	-20.23	-17.69	-20.55	-14.14
VH	LENS-	-1.82	DLL-	20.65	DLT-	20.58	DLT-	20.58
		-24.43	-24.45	-24.01	-24.64	-22.92	-21.12	-13.71

DATE- MAY 20, 1977 SITE- 3 LOOK- 3

VV	LENS-	-1.82	DLL-	20.65	DLT-	27.47	DLT-	24.53
		-27.21	-25.90	-25.12	-24.65	-22.13	-17.45	-14.21
VH	LENS-	-1.82	DLL-	20.65	DLT-	21.59	DLT-	21.59
		-24.17	-25.20	-24.92	-23.98	-23.76	-19.59	-17.71

DATE- MAY 20, 1977 SITE- 3 LOOK- 4

VV	LENS-	2.73	DLL-	27.72	DLT-	26.98	DLT-	27.31
		-27.59	-25.99	-24.61	-22.61	-20.92	-20.81	-13.14
VH	LENS-	2.73	DLL-	27.72	DLT-	27.64	DLT-	27.19
		-25.24	-24.84	-25.61	-22.64	-23.41	-18.64	-15.35

DATE- MAY 20, 1977 SITE- 3 LOOK- 5

VV	LENS-	2.73	DLL-	27.72	DLT-	26.89	DLT-	27.02
		-26.94	-24.41	-24.38	-25.50	-20.24	-11.93	-12.50
VH	LENS-	2.73	DLL-	27.72	DLT-	27.14	DLT-	27.14
		-25.89	-26.22	-25.83	-25.37	-23.78	-18.65	-14.99

DATE- MAY 21, 1977 SITE- 3 LOOK- 6

VV	LENS-	2.73	DLL-	27.72	DLT-	26.96	DLT-	26.96
		-26.71	-25.27	-23.00	-22.67	-23.90	-16.43	-10.38
VH	LENS-	2.73	DLL-	27.72	DLT-	27.45	DLT-	27.45
		-26.61	-26.12	-26.31	-25.92	-24.02	-23.88	-13.94

DATE- MAY 21, 1977 SITE- 4 LOOK- 1

VV	LENS-	2.73	DLL-	27.72	DLT-	26.46	DLT-	26.46
		-24.22	-19.72	-19.12	-14.72	-9.33	-9.44	-9.61
VH	LENS-	2.73	DLL-	27.72	DLT-	26.66	DLT-	26.66
		-25.34	-25.98	-21.98	-16.95	-13.91	-14.96	-14.83

DATE- MAY 22, 1977 SITE- 4 LOOK- 2

VV	LENS-	2.73	DLL-	27.72	DLT-	26.92	DLT-	26.88
		-19.25	-15.50	-14.64	-9.48	-9.59	-8.45	-5.92
VH	LENS-	2.73	DLL-	27.72	DLT-	26.80	DLT-	26.91
		-22.43	-20.96	-20.62	-16.69	-15.63	-12.38	-11.40

DATE- MAY 22, 1977 SITE- 5 LOOK- 1

VV	LENS-	5.20	DLL-	27.30	DLT-	26.78	DLT-	26.78
		-24.33	-19.92	-20.70	-17.97	-16.90	-14.04	-12.87
VH	LENS-	5.20	DLL-	27.30	DLT-	27.30	DLT-	27.30
		-27.58	-23.63	-23.51	-21.64	-21.66	-18.52	-15.36

DATE- MAY 23, 1977 SITE- 5 LOOK- 2

VV	LENS-	5.20	DLL-	27.30	DLT-	27.00	DLT-	27.15
		-23.98	-20.40	-18.70	-18.07	-15.53	-15.23	-8.78
VH	LENS-	5.20	DLL-	27.30	DLT-	27.63	DLT-	27.35
		-25.72	-24.02	-23.58	-20.20	-17.92	-20.43	-15.30

DATE- MAY 23, 1977 SITE- 5 LOOK- 3

VV	LENS-	5.20	DLL-	27.30	DLT-	27.52	DLT-	27.57
		-21.91	-21.30	-23.21	-23.64	-18.57	-14.50	-6.58
VH	LENS-	5.20	DLL-	27.30	DLT-	27.71	DLT-	27.71
		-23.03	-25.55	-24.63	-21.38	-22.06	-18.74	-11.80

DATE- MAY 23, 1977 SITE- 5 LOOK- 4

VV	LENS-	5.20	DLL-	27.30	DLT-	27.23	DLT-	27.23
		-23.92	-22.13	-21.23	-19.89	-17.64	-13.22	-12.98
VH	LENS-	5.20	DLL-	27.30	DLT-	27.23	DLT-	27.23
		-27.57	-26.73	-24.34	-22.23	-20.85	-18.44	-17.33

27

DATE- MAY 23, 1977 SITE- 5 LOOK- 5

VV	LENS-	5.20	DLL-	27.30	DLT-	27.23	DLT-	27.23
		-24.93	-21.05	-18.34	-18.31	-15.18	-14.92	-12.06
VH	LENS-	5.20	DLL-	27.30	DLT-	27.26	DLT-	27.23
		-24.50	-23.50	-22.18	-20.89	-20.98	-18.28	-13.55

DATE- MAY 23, 1977 SITE- 5 LOOK- 6

VV	LENS-	5.20	DLL-	27.30	DLT-	27.31	DLT-	27.31
		-22.96	-19.98	-16.98	-13.29	-15.44	-14.23	-8.64
VH	LENS-	5.20	DLL-	27.30	DLT-	27.31	DLT-	27.31
		-25.49	-25.65	-24.67	-19.09	-17.89	-18.67	-15.57

DATE- MAY 25, 1977 SITE- 6 LOOK- 1

VV	LENS-	9.62	DLL-	27.14	DLT-	27.14	DLT-	27.14
		-20.58	-20.73	-21.20	-19.57	-19.68	-12.57	-11.94
VH	LENS-	9.62	DLL-	27.14	DLT-	27.14	DLT-	27.14
		-23.58	-22.93	-23.76	-22.10	-22.46	-16.45	-12.93

DATE- MAY 25, 1977 SITE- 6 LOOK- 2

VV	LENS-	9.62	DLL-	27.14	DLT-	27.57	DLT-	27.57
		-20.54	-20.88	-20.43	-21.85	-21.85	-11.33	-11.41
VH	LENS-	9.62	DLL-	27.14	DLT-	27.57	DLT-	27.57
		-25.42	-23.40	-22.53	-22.92	-22.45	-18.33	-11.86

DATE- MAY 26, 1977 SITE- 6 LOOK- 3

VV	LENS-	9.62	DLL-	27.14	DLT-	27.69	DLT-	27.82
		-22.85	-21.94	-19.99	-21.30	-19.35	-13.87	-11.16
VH	LENS-	9.62	DLL-	27.14	DLT-	27.94	DLT-	27.65
		-23.75	-22.73	-22.93	-22.81	-21.86	-20.01	-12.80

DATE- MAY 26, 1977 SITE- 6 LOOK- 4

VV	LENS-	9.62	DLL-	27.14	DLT-	27.84	DLT-	27.75
		-22.58	-22.03	-21.36	-18.98	-20.12	-13.58	-8.89
VH	LENS-	9.62	DLL-	27.14	DLT-	27.65	DLT-	27.71
		-22.26	-24.50	-22.92	-21.12	-22.24	-18.52	-10.06

28

DATE- MAY 26, 1977 SITE- 6 LOOK- 5

VV	LENS-	9.62	DLL-	27.14	DLT-	27.65	DLT-	27.53
		-19.66	-20.79	-20.03	-20.40	-18.49	-14.79	-10.05
VH	LENS-	9.62	DLL-	27.14	DLT-	27.41	DLT-	27.52
		-23.50	-23.14	-23.52	-23.17	-22.51	-21.05	-12.96

DATE- MAY 28, 1977 SITE- 7 LOOK- 1

VV	LENS-	9.06	DLL-	27.69	DLT-	27.69	DLT-	27.67
		-25.30	-24.71	-21.41	-19.74	-18.19	-14.37	-11.04
VH	LENS-	9.06	DLL-	27.69	DLT-	27.65	DLT-	27.67
		-27.79	-25.95	-25.17	-23.74	-20.03	-17.63	-14.98

DATE- MAY 28, 1977 SITE- 7 LOOK- 2

VV	LENS-	9.06	DLL-	27.69	DLT-	27.50	DLT-	27.57
		-26.45	-25.47	-24.62	-23.49	-20.61	-14.24	-13.25
VH	LENS-	9.06	DLL-	27.69	DLT-	27.63	DLT-	27.62
		-26.64	-25.64	-24.90	-25.28	-23.11	-16.58	-19.50

DATE- MAY 28, 1977 SITE- 7 LOOK- 3

VV	LENS-	9.06	DLL-	27.69	DLT-	27.82	DLT-	27.71
		-24.01	-23.85	-22.42	-23.48	-19.58	-13.52	-11.17
VH	LENS-	9.06	DLL-	27.69	DLT-	27.61	DLT-	27.61
		-23.82	-23.92	-25.00	-24.49	-23.54	-18.55	-13.23

29

APPENDIX C. RAW KU-X-BAND DATA

Raw Ku-X-band data included here are listed according to date of experiment, site number, and look number. The transmit-receive configuration are indicated by VV, VH, HV, and HH shown to the left of the data. The nine Ku-X-band frequencies are 9, 10, 11, 12, 13, 14, 15, 16, 17 GHz, and their returns are listed as shown, left to right. The first row of data indicated by LENS are the lens returns. The second row indicated by DLL are the delay line returns measured at the time of the lens calibration. The third row indicated by DLT are the delay line returns measured at the start of the data run. The next 7 lines are the returns measured at the angle indicated to the left. Note that the angle indicated to the left is the angle off the horizon (complement of incidence angle). The last line indicated by DLT is the delay line return measured at the end of a data run.

## SEA ICE DATA

SPRING 1977 EXPERIMENT

DATE- MAY 14, 1977

SITE- 1 LOOK- 1

HH	LENS-	-6.79	-7.36	-8.75	-8.51	-8.05	-10.39	-14.15	-11.09	-13.54
	DLL-	20.15	17.34	14.50	12.25	11.98	11.80	8.41	3.84	2.11
	DLT-	20.15	17.34	14.50	12.25	11.98	11.80	8.41	3.84	2.11

## ANGLE

20	-48.10	-49.07	-49.27	-49.66	-47.43	-34.16	-38.82	-51.39	-55.05
30	-31.94	-33.24	-32.98	-33.88	-36.74	-31.74	-33.95	-51.82	-50.86
40	-32.93	-33.46	-30.30	-35.25	-31.48	-30.25	-34.87	-51.79	-53.33
50	-31.86	-31.31	-34.83	-34.40	-33.67	-35.04	-37.52	-47.73	-50.89
60	-27.61	-31.88	-32.45	-30.42	-31.16	-31.69	-32.36	-34.63	-53.27
70	-37.80	-37.99	-37.46	-31.07	-28.43	-28.51	-33.82	-38.39	-38.15
80	-33.36	-35.29	-30.16	-30.30	-27.08	-36.82	-33.46	-33.01	-34.47
DLT-	20.15	17.34	14.50	12.25	11.98	11.80	8.41	3.84	2.11

HV	LENS-	-34.08	-37.14	-38.74	-36.97	-36.05	-37.30	-41.47	-38.45	-37.20
	DLL-	20.15	17.34	14.50	12.25	11.98	11.80	8.41	3.84	2.11
	DLT-	20.15	17.34	14.50	12.25	11.98	11.80	8.41	3.84	2.11

## ANGLE

20	-49.49	-52.45	-48.39	-51.58	-50.75	-49.05	-51.32	-51.21	-58.11
30	-55.62	-56.20	-47.60	-56.50	-57.40	-53.30	-56.59	-51.60	-54.87
40	-53.78	-55.08	-47.33	-56.56	-52.74	-53.85	-55.05	-51.04	-51.54
50	-52.89	-54.75	-48.40	-54.88	-51.72	-53.32	-56.59	-49.49	-54.72
60	-52.70	-54.10	-47.80	-57.77	-52.73	-52.27	-56.75	-50.27	-53.95
70	-51.34	-51.00	-47.95	-55.49	-55.10	-55.94	-55.15	-50.47	-56.10
80	-34.10	-37.73	-36.35	-50.55	-52.97	-51.87	-55.64	-53.06	-56.46
DLT-	20.15	17.34	14.50	12.25	11.98	11.80	8.41	3.84	2.11

VV	LENS-	-7.57	-8.96	-10.15	-10.29	-10.63	-16.92	-17.58	-14.59	-17.45
	DLL-	20.15	17.34	14.50	12.25	11.98	11.80	8.41	3.84	2.11
	DLT-	20.15	17.34	14.50	12.25	11.98	11.80	8.41	3.84	2.11

## ANGLE

20	-38.24	-38.04	-35.08	-38.33	-35.49	-33.59	-38.79	-51.50	-53.94
30	-32.89	-33.08	-32.76	-35.17	-34.74	-33.33	-36.05	-52.97	-52.95
40	-34.00	-33.63	-29.61	-35.11	-32.08	-31.55	-38.36	-52.80	-53.82
50	-30.87	-31.15	-33.73	-32.00	-31.46	-34.28	-35.91	-38.35	-50.34
60	-35.48	-31.92	-31.31	-33.15	-29.17	-31.05	-32.96	-38.47	-54.23
70	-30.38	-28.14	-27.88	-31.65	-27.36	-27.12	-37.02	-38.78	-53.25
80	-34.09	-35.85	-31.51	-29.86	-26.49	-35.20	-35.12	-36.88	-38.64
DLT-	20.15	17.34	14.50	12.25	11.98	11.80	8.41	3.84	2.11

VH	LENS-	-36.04	-39.43	-37.21	-38.96	-37.72	-43.65	-38.43	-41.95	-42.44
	DLL-	20.15	17.34	14.50	12.25	11.98	11.80	8.41	3.84	2.11
	DLT-	20.15	17.34	14.50	12.25	11.98	11.80	8.41	3.84	2.11

ANGLE

20	-57.93	-51.79	-46.87	-53.78	-51.97	-49.66	-51.73	-52.39	-49.80
30	-56.41	-55.21	-47.04	-56.94	-57.32	-54.87	-57.12	-54.03	-49.18
40	-53.58	-55.63	-46.80	-56.62	-52.66	-54.64	-56.92	-52.84	-48.27
50	-52.60	-55.68	-46.49	-54.88	-52.58	-53.13	-49.51	-51.98	-48.86
60	-51.33	-53.62	-46.67	-56.92	-51.96	-52.87	-55.75	-52.58	-49.33
70	-51.90	-51.10	-36.02	-55.95	-52.91	-53.95	-56.81	-54.51	-49.14
80	-35.02	-49.76	-35.66	-51.15	-53.12	-51.66	-56.35	-55.77	-49.16
DLT-	20.15	17.34	14.50	12.25	11.98	11.80	8.41	3.84	2.11

## SEA ICE DATA SPRING 1977 EXPERIMENT

DATE- MAY 14, 1977 SITE- 1 LOOK- 2

HH	LENS-	-6.79	-7.36	-8.75	-8.51	-8.05	-10.39	-14.15	-11.09	-13.54
	DLL-	20.15	17.34	14.50	12.25	11.98	11.80	8.41	3.84	2.11
	DLT-	14.55	12.21	9.33	6.66	6.49	6.39	7.97	3.30	2.07

## ANGLE

20	-34.13	-35.46	-37.35	-38.57	-36.64	-35.14	-46.74	-50.33	-50.66
30	-33.80	-33.21	-33.62	-35.98	-33.86	-31.54	-46.91	-49.00	-52.42
40	-30.92	-32.90	-29.86	-30.04	-30.63	-32.91	-34.39	-47.79	-50.50
50	-31.93	-29.85	-30.75	-34.50	-30.78	-28.70	-28.36	-35.04	-34.54
60	-29.70	-32.91	-31.59	-31.95	-32.40	-26.41	-34.85	-37.23	-54.85
70	-28.14	-27.96	-29.83	-29.49	-28.06	-34.79	-31.43	-36.83	-36.34
80	-35.01	-30.11	-28.50	-27.65	-32.44	-31.38	-31.32	-37.90	-37.46
DLT-	17.20	15.91	12.53	10.14	9.02	8.79	9.36	3.53	2.40

HV	LENS-	-34.08	-37.14	-38.74	-36.97	-36.05	-37.30	-41.47	-38.45	-37.20
	DLL-	20.15	17.34	14.50	12.25	11.98	11.80	8.41	3.84	2.11
	DLT-	17.20	15.91	12.53	10.14	9.02	8.79	9.36	3.53	2.40

## ANGLE

20	-57.57	-56.28	-48.66	-51.02	-48.00	-46.87	-49.32	-52.88	-52.70
30	-56.94	-54.12	-48.41	-55.36	-56.92	-52.78	-54.32	-50.81	-53.72
40	-53.09	-55.45	-48.40	-54.41	-50.40	-53.46	-55.79	-51.18	-49.24
50	-54.17	-53.62	-47.29	-53.57	-53.05	-52.55	-54.55	-52.80	-53.63
60	-50.53	-50.00	-48.40	-51.92	-51.37	-52.44	-53.81	-51.32	-52.43
70	-56.12	-56.73	-47.81	-58.58	-49.44	-52.94	-55.40	-50.35	-53.58
80	-37.58	-38.10	-36.81	-51.69	-47.59	-47.78	-55.99	-50.42	-47.04
DLT-	19.85	19.62	15.73	13.63	11.56	11.19	10.75	3.76	2.72

VV	LENS-	-7.57	-8.96	-10.15	-10.29	-10.63	-16.92	-17.58	-14.59	-17.45
	DLL-	20.15	17.34	14.50	12.25	11.98	11.80	8.41	3.84	2.11
	DLT-	19.85	19.62	15.73	13.63	11.56	11.19	10.75	3.76	2.72

## ANGLE

20	-34.19	-35.27	-35.31	-38.23	-34.81	-33.93	-36.55	-51.24	-50.16
30	-33.12	-33.45	-31.42	-35.59	-34.07	-33.35	-34.59	-38.54	-53.09
40	-30.03	-33.10	-30.00	-30.62	-29.30	-27.64	-34.31	-38.31	-49.83
50	-30.34	-28.95	-29.10	-35.33	-29.45	-28.81	-31.89	-37.20	-37.21
60	-31.55	-32.53	-29.52	-33.56	-36.52	-35.37	-32.07	-36.62	-50.09
70	-37.96	-36.91	-37.10	-37.41	-35.72	-37.60	-35.46	-37.14	-50.00
80	-32.86	-35.87	-30.58	-27.28	-32.80	-33.28	-38.38	-35.88	-38.21
DLT-	19.85	19.62	15.73	13.63	11.56	11.19	10.75	3.76	2.72

VH	LENS-	-36.04	-39.43	-37.21	-38.96	-37.72	-43.65	-38.43	-41.95	-42.44
	DLL-	20.15	17.34	14.50	12.25	11.98	11.80	8.41	3.84	2.11
	DLT-	19.85	19.62	15.73	13.63	11.56	11.19	10.75	3.76	2.72

ANGLE

20	-57.58	-56.39	-47.05	-51.89	-49.26	-47.86	-49.82	-52.93	-48.10
30	-57.10	-54.60	-46.86	-55.74	-57.65	-54.68	-54.73	-50.48	-47.90
40	-53.34	-55.05	-47.25	-54.31	-52.25	-52.63	-55.97	-50.27	-47.86
50	-54.92	-54.02	-46.38	-54.24	-52.74	-50.95	-54.75	-50.27	-49.02
60	-50.41	-50.72	-46.38	-53.25	-49.89	-52.16	-53.45	-50.21	-49.95
70	-55.64	-54.39	-35.77	-49.31	-53.42	-51.90	-56.65	-50.79	-48.72
80	-46.93	-48.11	-46.92	-51.20	-48.27	-48.65	-51.80	-57.88	-58.50
DLT-	19.85	19.62	15.73	13.63	11.56	11.19	10.75	3.76	2.72

## SEA ICE DATA

SPRING 1977 EXPERIMENT

DATE- MAY 14, 1977

SITE- 1 LOOK- 3

HH	LENS-	-6.79	-7.36	-8.75	-8.51	-8.05	-10.39	-14.15	-11.09	-13.54
	DLL-	20.15	17.34	14.50	12.25	11.98	11.80	8.41	3.84	2.11
	DLT-	14.72	12.52	9.43	6.61	6.42	6.38	8.64	4.04	2.93

## ANGLE

20	-33.55	-36.22	-35.84	-34.21	-35.36	-36.31	-32.85	-49.82	-49.97
30	-30.77	-30.83	-33.60	-31.09	-30.99	-31.88	-34.58	-36.81	-38.03
40	-29.01	-31.43	-27.19	-28.42	-29.24	-31.03	-31.00	-37.08	-34.55
50	-32.69	-27.87	-31.23	-28.17	-29.51	-29.88	-32.98	-35.36	-33.71
60	-38.22	-30.16	-27.12	-32.29	-29.60	-35.86	-34.07	-35.43	-36.68
70	-37.67	-31.24	-31.00	-27.58	-31.11	-28.33	-31.32	-35.08	-32.80
80	-30.05	-33.95	-38.04	-35.26	-31.16	-26.94	-26.56	-34.93	-36.00
DLT-	16.77	14.47	11.51	9.06	8.38	8.36	7.75	2.94	-3.02

HV	LENS-	-34.08	-37.14	-38.74	-36.97	-36.05	-37.30	-41.47	-38.45	-37.20
	DLL-	20.15	17.34	14.50	12.25	11.98	11.80	8.41	3.84	2.11
	DLT-	16.77	14.47	11.51	9.06	8.38	8.36	7.75	2.94	-3.02

## ANGLE

20	-55.73	-53.63	-48.13	-54.22	-51.72	-52.68	-55.28	-58.01	-50.47
30	-51.30	-53.35	-48.38	-52.40	-52.04	-52.09	-53.43	-56.60	-57.66
40	-51.58	-50.76	-48.78	-51.71	-50.26	-50.33	-51.75	-56.99	-50.64
50	-49.52	-52.22	-48.07	-52.56	-51.93	-50.58	-49.30	-57.02	-49.74
60	-50.81	-47.85	-35.91	-51.74	-50.00	-48.92	-54.14	-57.60	-53.96
70	-36.86	-51.10	-48.73	-53.24	-51.49	-33.32	-52.11	-49.75	-54.08
80	-51.77	-56.08	-49.80	-51.01	-51.69	-49.22	-51.95	-53.11	-54.70
DLT-	18.81	16.42	13.60	11.51	10.34	10.34	6.86	1.84	-8.96

VV	LENS-	-7.57	-8.96	-10.15	-10.29	-10.63	-16.92	-17.58	-14.59	-17.45
	DLL-	20.15	17.34	14.50	12.25	11.98	11.80	8.41	3.84	2.11
	DLT-	18.81	16.42	13.60	11.51	10.34	10.34	6.86	1.84	-8.96

## ANGLE

20	-33.20	-34.38	-33.80	-33.06	-34.05	-34.59	-31.77	-50.39	-50.48
30	-32.14	-31.56	-30.97	-31.08	-30.89	-31.44	-33.76	-38.65	-52.77
40	-29.21	-29.49	-28.87	-31.05	-29.99	-32.80	-32.10	-38.86	-49.38
50	-31.43	-27.84	-29.81	-28.50	-29.05	-32.03	-33.22	-38.69	-37.16
60	-37.07	-29.42	-27.99	-32.39	-31.69	-28.09	-32.21	-36.30	-50.33
70	-37.93	-34.83	-31.06	-28.82	-28.89	-27.79	-31.44	-35.76	-50.75
80	-30.46	-33.56	-32.01	-26.74	-27.95	-30.42	-28.93	-34.35	-50.10
DLT-	18.81	16.42	13.60	11.51	10.34	10.34	6.86	1.84	-8.96

VH	LENS-	-36.04	-39.43	-37.21	-38.96	-37.72	-43.65	-38.43	-41.95	-42.44
	DLL-	20.15	17.34	14.50	12.25	11.98	11.80	8.41	3.84	2.11
	DLT-	18.81	16.42	13.60	11.51	10.34	10.34	6.86	1.84	-8.96

ANGLE

20	-56.43	-54.92	-46.95	-56.33	-55.52	-55.84	-57.85	-50.63	-49.20
30	-51.93	-53.97	-46.54	-52.85	-53.10	-53.73	-54.79	-49.46	-47.16
40	-52.25	-51.36	-46.89	-51.94	-51.47	-51.70	-54.01	-50.00	-50.07
50	-49.91	-52.25	-35.64	-52.00	-51.29	-51.29	-51.46	-57.42	-56.80
60	-49.98	-49.46	-35.06	-52.34	-51.19	-47.81	-53.39	-49.95	-46.66
70	-47.63	-50.83	-46.32	-54.11	-54.31	-34.52	-53.10	-49.86	-46.78
80	-50.95	-53.92	-47.31	-52.47	-53.04	-50.36	-53.76	-53.34	-54.80
DLT-	18.81	16.42	13.60	11.51	10.34	10.34	6.86	1.84	-8.96

## SEA ICE DATA

## SPRING 1977 EXPERIMENT

DATE- MAY 15, 1977

SITE- 1 LOOK- 4

HH	LENS-	4.66	4.81	4.18	3.77	4.86	4.84	0.52	-4.40	-5.99
	DLL-	22.49	19.99	17.30	14.93	14.57	14.68	10.50	5.57	4.67
	DLT-	22.49	19.99	17.30	14.93	14.57	14.68	10.50	5.57	4.67

## ANGLE

20	-36.13	-38.38	-38.37	-37.33	-36.00	-35.40	-37.71	-43.52	-43.76
30	-35.97	-34.75	-36.62	-35.58	-32.03	-34.22	-35.38	-40.55	-40.69
40	-35.14	-32.92	-32.99	-36.21	-31.29	-31.00	-32.34	-38.31	-36.39
50	-31.39	-33.03	-30.34	-33.13	-32.74	-32.20	-32.25	-40.79	-43.96
60	-32.61	-30.20	-32.13	-29.86	-29.48	-30.39	-34.92	-38.18	-40.25
70	-27.53	-28.50	-30.86	-27.56	-27.73	-27.73	-31.03	-38.53	-48.19
80	-22.25	-22.87	-21.56	-28.00	-20.90	-23.67	-32.28	-34.23	-37.82
DLT-	22.20	19.62	16.87	14.50	14.13	14.20	9.93	5.04	3.87

HV	LENS-	-25.81	-25.82	-25.81	-23.95	-26.11	-28.00	-27.12	-31.76	-29.65
	DLL-	22.49	19.99	17.30	14.93	14.57	14.68	10.50	5.57	4.67
	DLT-	22.20	19.62	16.87	14.50	14.13	14.20	9.93	5.04	3.87

## ANGLE

20	-48.59	-47.80	-42.36	-47.98	-48.18	-48.50	-50.56	-51.12	-55.94
30	-46.29	-45.90	-40.46	-46.15	-46.46	-45.69	-51.46	-50.65	-51.19
40	-46.53	-47.60	-41.18	-45.87	-46.48	-47.50	-47.15	-51.49	-52.41
50	-42.09	-43.96	-39.60	-46.43	-46.26	-44.65	-44.65	-50.22	-53.67
60	-43.65	-42.24	-40.11	-43.40	-42.47	-43.05	-42.48	-46.57	-55.79
70	-43.99	-43.99	-43.11	-41.16	-41.57	-40.72	-43.42	-48.31	-48.80
80	-46.04	-46.48	-40.42	-43.98	-42.85	-39.24	-47.60	-52.54	-49.29
DLT-	21.90	19.25	16.44	14.07	13.68	13.72	9.35	4.50	3.06

VV	LENS-	3.88	3.21	2.48	1.99	2.28	1.69	-2.91	-7.90	-9.90
	DLL-	22.49	19.99	17.30	14.93	14.57	14.68	10.50	5.57	4.67
	DLT-	21.90	19.25	16.44	14.07	13.68	13.72	9.35	4.50	3.06

## ANGLE

20	-34.50	-36.37	-35.83	-38.21	-35.38	-35.57	-38.47	-42.41	-44.16
30	-34.26	-33.16	-35.69	-35.34	-34.13	-32.82	-36.54	-41.69	-40.74
40	-36.88	-33.56	-32.68	-38.39	-33.53	-31.12	-33.82	-42.06	-42.04
50	-31.28	-30.87	-32.40	-33.11	-32.23	-30.93	-32.31	-42.50	-46.04
60	-31.33	-30.28	-33.72	-29.76	-30.00	-30.17	-36.26	-37.91	-37.04
70	-27.56	-28.12	-32.48	-28.65	-29.10	-28.56	-30.30	-38.29	-42.98
80	-21.87	-20.89	-22.36	-26.96	-20.84	-23.77	-27.76	-34.36	-35.71
DLT-	21.90	19.25	16.44	14.07	13.68	13.72	9.35	4.50	3.06

VH	LENS-	-22.41	-27.26	-24.58	-21.03	-23.65	-23.42	-25.60	-31.44	-34.89
	DLL-	22.49	19.99	17.30	14.93	14.57	14.68	10.50	5.57	4.67
	DLT-	21.90	19.25	16.44	14.07	13.68	13.72	9.35	4.50	3.06

ANGLE

20	-48.24	-49.61	-38.99	-48.78	-50.48	-49.05	-49.06	-52.92	-56.71
30	-46.92	-46.38	-39.08	-47.07	-46.82	-46.50	-49.78	-51.89	-52.23
40	-46.20	-47.96	-38.90	-45.78	-46.51	-48.70	-46.63	-53.09	-51.76
50	-43.35	-43.78	-38.89	-47.81	-48.26	-45.24	-43.70	-51.67	-53.69
60	-43.01	-42.55	-39.28	-43.23	-43.03	-42.45	-41.81	-49.69	-53.62
70	-44.06	-43.34	-39.87	-42.07	-41.73	-41.94	-45.00	-50.66	-50.62
80	-42.82	-42.99	-38.37	-44.54	-42.37	-41.21	-52.12	-56.38	-49.81
DLT-	21.90	19.25	16.44	14.07	13.68	13.72	9.35	4.50	3.06

## SEA ICE DATA

## SPRING 1977 EXPERIMENT

DATE- MAY 15, 1977

SITE- 1 LOOK- 5

HH	LENS-	4.66	4.81	4.18	3.77	4.86	4.84	0.52	-4.40	-5.99
	DLL-	22.49	19.99	17.30	14.93	14.57	14.68	10.50	5.57	4.67
	DLT-	20.49	18.13	14.55	12.43	12.42	12.61	10.70	6.95	4.42

## ANGLE

20	-36.11	-37.51	-37.04	-36.95	-35.88	-33.77	-37.11	-38.70	-42.07
30	-33.58	-32.76	-34.33	-36.82	-35.35	-31.70	-36.30	-37.45	-37.54
40	-31.74	-33.60	-34.63	-32.55	-31.25	-30.69	-32.35	-37.00	-38.37
50	-30.33	-33.37	-28.54	-32.96	-31.57	-29.93	-30.09	-37.12	-36.35
60	-26.90	-25.76	-27.16	-32.16	-27.97	-34.01	-32.89	-38.76	-46.44
70	-29.26	-25.46	-26.12	-28.20	-30.89	-27.72	-33.97	-36.05	-32.59
80	-22.32	-18.20	-17.67	-22.61	-17.78	-20.90	-25.49	-26.48	-34.19
DLT-	21.17	18.74	15.53	13.27	13.05	13.19	10.31	6.08	4.30

HV	LENS-	-25.81	-25.82	-25.81	-23.95	-26.11	-28.00	-27.12	-31.76	-29.65
	DLL-	22.49	19.99	17.30	14.93	14.57	14.68	10.50	5.57	4.67
	DLT-	21.17	18.74	15.53	13.27	13.05	13.19	10.31	6.08	4.30

## ANGLE

20	-47.81	-49.17	-44.45	-47.78	-45.17	-45.57	-45.73	-48.14	-54.18
30	-44.45	-45.50	-43.64	-46.51	-42.68	-43.90	-43.09	-47.85	-49.75
40	-46.07	-43.22	-41.73	-44.89	-40.42	-40.45	-43.49	-48.06	-50.21
50	-45.13	-44.36	-39.37	-44.17	-43.14	-41.53	-43.31	-46.45	-54.23
60	-41.14	-40.59	-42.84	-44.31	-41.90	-43.94	-48.66	-48.73	-51.71
70	-43.58	-40.38	-40.50	-43.45	-41.63	-42.48	-43.12	-47.19	-48.77
80	-40.22	-41.12	-42.78	-39.01	-43.92	-44.53	-43.55	-42.70	-45.98
DLT-	21.86	19.35	16.52	14.11	13.68	13.76	9.91	5.21	4.18

VV	LENS-	3.88	3.21	2.48	1.99	2.28	1.69	-2.91	-7.90	-9.90
	DLL-	22.49	19.99	17.30	14.93	14.57	14.68	10.50	5.57	4.67
	DLT-	21.86	19.35	16.52	14.11	13.68	13.76	9.91	5.21	4.18

## ANGLE

20	-33.39	-33.91	-33.50	-33.89	-34.89	-30.85	-35.09	-40.37	-41.04
30	-34.39	-30.71	-35.10	-34.75	-32.39	-31.42	-32.27	-38.62	-39.49
40	-27.82	-31.30	-31.89	-30.83	-29.41	-28.40	-35.72	-35.82	-40.39
50	-30.99	-32.53	-28.80	-31.88	-28.68	-31.08	-35.01	-39.72	-39.56
60	-28.18	-25.68	-29.17	-29.12	-24.17	-32.65	-31.88	-35.92	-42.10
70	-26.46	-24.78	-26.72	-27.72	-29.47	-26.97	-32.38	-38.40	-32.99
80	-19.47	-18.18	-19.37	-21.32	-18.79	-15.64	-29.48	-26.96	-30.86
DLT-	21.86	19.35	16.52	14.11	13.68	13.76	9.91	5.21	4.18

VH	LENS-	-22.41	-27.26	-24.58	-21.03	-23.65	-23.42	-25.60	-31.44	-34.89
	DLL-	22.49	19.99	17.30	14.93	14.57	14.68	10.50	5.57	4.67
	DLT-	21.86	19.35	16.52	14.11	13.68	13.76	9.91	5.21	4.18

ANGLE

20	-48.31	-47.60	-41.98	-47.13	-46.44	-46.43	-48.11	-52.00	-55.98
30	-44.88	-45.75	-41.70	-47.10	-43.71	-43.89	-46.07	-53.11	-51.22
40	-45.11	-42.96	-41.34	-47.71	-43.02	-42.07	-46.32	-51.19	-52.22
50	-45.15	-46.88	-39.40	-44.12	-44.24	-43.22	-46.26	-48.22	-55.15
60	-43.67	-41.62	-41.58	-41.95	-42.18	-42.33	-46.33	-51.35	-54.21
70	-41.05	-38.96	-41.14	-47.31	-41.73	-45.66	-45.66	-51.76	-51.66
80	-36.57	-40.67	-39.70	-41.26	-40.28	-42.59	-45.43	-48.28	-52.41
DLT-	21.86	19.35	16.52	14.11	13.68	13.76	9.91	5.21	4.18

## SEA ICE DATA SPRING 1977 EXPERIMENT

DATE- MAY 17, 1977 SITE- 2 LOOK- 1

HH	LENS-	1.62	0.44	-1.46	-1.47	-0.75	-5.29	-11.48	-13.22	-37.42
	DLL-	20.44	17.74	14.30	12.31	12.44	10.08	5.98	2.95	-9.46
	DLT-	22.53	19.73	16.93	15.30	15.78	13.71	8.62	6.87	-4.10

## ANGLE

20	-27.78	-27.50	-29.40	-27.36	-29.09	-33.45	-37.19	-37.05	-52.07
30	-23.93	-25.73	-25.87	-26.13	-27.05	-26.62	-32.88	-33.96	-52.10
40	-21.55	-21.48	-27.21	-27.21	-23.41	-25.42	-33.20	-32.91	-52.54
50	-21.67	-24.05	-26.28	-25.71	-24.50	-27.25	-35.62	-31.21	-50.84
60	-23.07	-22.48	-21.70	-22.79	-22.18	-26.55	-34.91	-34.11	-49.69
70	-17.81	-18.06	-21.64	-16.83	-18.67	-18.86	-31.27	-29.29	-46.37
80	-16.83	-18.29	-15.56	-20.36	-23.19	-25.70	-27.06	-32.49	-47.49
DLT-	22.01	19.23	16.27	14.55	14.95	12.80	7.96	5.89	-5.44

HV	LENS-	-27.00	-25.75	-24.31	-24.06	-25.02	-27.28	-32.10	-31.41	-54.92
	DLL-	20.44	17.74	14.30	12.31	12.44	10.08	5.98	2.95	-9.46
	DLT-	22.01	19.23	16.27	14.55	14.95	12.80	7.96	5.89	-5.44

## ANGLE

20	-36.48	-35.64	-38.39	-41.27	-35.40	-42.18	-43.92	-46.17	-49.22
30	-34.05	-35.16	-34.45	-35.65	-35.18	-38.34	-40.89	-42.58	-55.89
40	-31.96	-34.72	-37.39	-36.97	-33.94	-36.92	-41.40	-44.06	-57.04
50	-31.62	-31.88	-34.12	-31.51	-33.78	-34.37	-43.95	-40.15	-63.27
60	-32.30	-30.80	-30.57	-35.67	-31.50	-38.61	-37.45	-41.41	-61.42
70	-27.03	-32.39	-33.08	-33.66	-35.36	-37.57	-37.46	-42.28	-56.02
80	-29.33	-31.93	-34.99	-32.27	-28.13	-40.67	-40.62	-43.22	-58.73
DLT-	21.49	18.74	15.62	13.80	14.11	11.90	7.30	4.91	-6.78

VV	LENS-	1.01	-0.01	-1.20	-1.52	-0.41	-3.67	-8.54	-13.83	-37.87
	DLL-	20.44	17.74	14.30	12.31	12.44	10.08	5.98	2.95	-9.46
	DLT-	21.49	18.74	15.62	13.80	14.11	11.90	7.30	4.91	-6.78

## ANGLE

20	-25.36	-28.31	-30.71	-27.59	-26.70	-31.71	-35.36	-37.42	-48.65
30	-24.53	-25.02	-26.02	-25.74	-27.63	-26.84	-34.10	-34.62	-49.03
40	-22.18	-19.94	-25.07	-30.26	-27.82	-24.21	-32.80	-33.68	-50.10
50	-19.43	-22.20	-26.35	-24.73	-21.90	-26.33	-35.66	-30.26	-48.67
60	-23.26	-19.83	-21.03	-21.53	-21.02	-25.07	-33.75	-35.24	-45.38
70	-17.56	-16.99	-21.66	-21.11	-18.90	-23.75	-28.50	-29.79	-47.89
80	-13.56	-16.41	-15.35	-21.60	-21.31	-29.93	-26.97	-31.33	-46.46
DLT-	20.96	18.24	14.96	13.06	13.28	10.99	6.64	3.93	-8.12

VH	LENS-	-28.34	-30.62	-28.48	-29.87	-29.65	-30.32	-32.66	-32.60	-52.57
	DLL-	20.44	17.74	14.30	12.31	12.44	10.08	5.98	2.95	-9.46
	DLT-	20.96	18.24	14.96	13.06	13.28	10.99	6.64	3.93	-8.12

ANGLE

20	-37.86	-36.76	-38.40	-42.43	-37.04	-43.64	-47.63	-48.61	-65.52
30	-35.91	-36.83	-34.86	-36.39	-36.42	-41.57	-43.32	-48.07	-65.07
40	-31.44	-35.02	-37.62	-37.59	-35.08	-40.37	-42.13	-46.65	-65.18
50	-31.31	-34.00	-33.98	-32.95	-32.55	-37.79	-45.74	-43.26	-48.74
60	-33.28	-31.37	-30.83	-33.73	-31.65	-37.61	-42.32	-47.61	-47.00
70	-27.86	-32.73	-34.08	-37.98	-35.79	-31.95	-38.63	-48.58	-46.59
80	-28.60	-31.15	-32.51	-33.78	-30.24	-38.80	-41.74	-41.82	-48.27
DLT-	20.44	17.74	14.30	12.31	12.44	10.08	5.98	2.95	-9.46

## SEA ICE DATA

SPRING 1977 EXPERIMENT

DATE- MAY 17, 1977

SITE- 2 LOOK- 2

HH	LENS-	1.62	0.44	-1.46	-1.47	-0.75	-5.29	-11.48	-13.22	-37.42
	DLL-	20.44	17.74	14.30	12.31	12.44	10.08	5.98	2.95	-9.46
	DLT-	21.85	19.17	15.91	14.26	14.38	12.58	7.35	5.30	-4.21

## ANGLE

20	-28.46	-27.56	-28.46	-28.17	-27.75	-32.25	-34.67	-37.65	-59.77
30	-24.34	-27.76	-32.13	-29.28	-24.43	-27.16	-33.78	-36.90	-60.38
40	-24.97	-23.63	-25.48	-22.79	-26.66	-27.16	-33.38	-33.38	-56.02
50	-20.92	-21.24	-28.90	-24.42	-22.31	-26.34	-30.67	-38.21	-58.68
60	-22.50	-23.61	-19.49	-23.73	-26.61	-28.45	-30.68	-35.23	-58.26
70	-16.24	-21.80	-24.27	-22.66	-23.18	-25.82	-31.97	-32.48	-51.98
80	-10.06	-20.87	-23.84	-19.46	-18.37	-22.73	-30.31	-27.66	-45.96

DLT-	21.85	19.17	15.91	14.26	14.38	12.58	7.35	5.30	-4.21
------	-------	-------	-------	-------	-------	-------	------	------	-------

HV	LENS-	-27.00	-25.75	-24.31	-24.06	-25.02	-27.28	-32.10	-31.41	-54.92
	DLL-	20.44	17.74	14.30	12.31	12.44	10.08	5.98	2.95	-9.46
	DLT-	21.85	19.17	15.91	14.26	14.38	12.58	7.35	5.30	-4.21

## ANGLE

20	-38.22	-36.86	-37.52	-36.63	-37.84	-45.82	-50.01	-52.99	-65.72
30	-35.06	-35.79	-36.55	-35.00	-35.33	-42.98	-47.61	-46.90	-64.53
40	-36.60	-33.04	-33.16	-36.30	-33.91	-37.85	-48.55	-49.73	-66.50
50	-32.59	-34.32	-34.29	-34.96	-33.02	-40.68	-41.45	-46.23	-64.84
60	-33.44	-32.70	-34.22	-34.69	-37.50	-37.32	-44.34	-46.47	-62.24
70	-33.48	-35.81	-31.36	-31.86	-36.93	-37.17	-42.40	-38.94	-63.65
80	-31.75	-29.48	-29.43	-31.37	-30.62	-32.55	-40.29	-41.38	-55.94

DLT-	21.85	19.17	15.91	14.26	14.38	12.58	7.35	5.30	-4.21
------	-------	-------	-------	-------	-------	-------	------	------	-------

VV	LENS-	1.01	-0.01	-1.20	-1.52	-0.41	-3.67	-8.54	-13.83	-37.87
	DLL-	20.44	17.74	14.30	12.31	12.44	10.08	5.98	2.95	-9.46
	DLT-	21.85	19.17	15.91	14.26	14.38	12.58	7.35	5.30	-4.21

## ANGLE

20	-26.13	-25.79	-29.85	-26.79	-29.11	-30.13	-37.20	-40.27	-60.60
30	-23.79	-27.26	-28.19	-29.84	-24.66	-28.66	-32.81	-35.97	-59.07
40	-26.02	-26.04	-26.10	-24.11	-25.91	-27.41	-38.81	-38.47	-48.66
50	-20.80	-22.77	-28.15	-26.39	-22.76	-28.18	-30.54	-36.71	-58.83
60	-23.48	-20.86	-19.35	-23.66	-26.79	-27.98	-33.12	-35.24	-54.88
70	-15.80	-22.73	-21.42	-20.98	-21.25	-25.73	-32.04	-34.50	-57.68
80	-11.73	-23.00	-25.47	-23.37	-19.74	-28.46	-29.48	-27.34	-54.44

DLT-	21.85	19.17	15.91	14.26	14.38	12.58	7.35	5.30	-4.21
------	-------	-------	-------	-------	-------	-------	------	------	-------

VH	LENS-	-28.34	-30.62	-28.48	-29.87	-29.65	-30.32	-32.66	-32.60	-52.57
	DLL-	20.44	17.74	14.30	12.31	12.44	10.08	5.98	2.95	-9.46
	DLT-	21.85	19.17	15.91	14.26	14.38	12.58	7.35	5.30	-4.21

ANGLE

20	-38.83	-38.14	-35.30	-37.11	-39.49	-46.01	-50.98	-54.28	-66.66
30	-35.55	-35.52	-35.16	-35.45	-37.21	-44.11	-47.36	-48.70	-64.91
40	-37.85	-34.46	-33.77	-36.28	-35.08	-39.79	-51.13	-52.90	-66.76
50	-31.70	-34.64	-34.02	-36.82	-32.32	-38.07	-44.20	-48.23	-65.07
60	-32.54	-33.95	-32.30	-40.21	-34.40	-41.53	-50.36	-48.43	-64.60
70	-32.89	-36.27	-33.38	-33.85	-37.29	-39.77	-45.29	-40.88	-63.71
80	-30.10	-31.15	-30.47	-30.88	-32.48	-37.05	-48.45	-48.05	-61.57
DLT-	21.85	19.17	15.91	14.26	14.38	12.58	7.35	5.30	-4.21

## SEA ICE DATA

SPRING 1977 EXPERIMENT

DATE- MAY 17, 1977

SITE- 2 LOOK- 3

HH	LENS-	1.62	0.44	-1.46	-1.47	-0.75	-5.29	-11.48	-13.22	-37.42
	DLL-	20.44	17.74	14.30	12.31	12.44	10.08	5.98	2.95	-9.46
	DLT-	21.31	18.53	15.16	13.66	13.49	11.88	6.47	4.39	-6.04

## ANGLE

20	-34.67	-31.30	-33.13	-34.57	-34.71	-37.14	-40.53	-42.31	-58.48
30	-29.34	-26.83	-30.08	-30.09	-27.74	-32.43	-35.83	-38.24	-60.58
40	-23.80	-26.92	-26.85	-26.03	-24.87	-29.84	-33.76	-39.86	-58.66
50	-21.86	-24.96	-25.69	-19.23	-27.77	-27.87	-33.01	-33.24	-54.70
60	-16.92	-24.06	-24.25	-24.27	-20.60	-26.49	-33.19	-36.20	-56.37
70	-23.40	-17.90	-23.08	-20.68	-26.16	-32.28	-33.57	-28.76	-55.95
80	-20.32	-20.92	-19.57	-18.09	-21.56	-21.11	-31.21	-30.74	-50.54

DLT-	21.31	18.53	15.16	13.66	13.49	11.88	6.47	4.39	-6.04
------	-------	-------	-------	-------	-------	-------	------	------	-------

HV	LENS-	-27.00	-25.75	-24.31	-24.06	-25.02	-27.28	-32.10	-31.41	-54.92
	DLL-	20.44	17.74	14.30	12.31	12.44	10.08	5.98	2.95	-9.46
	DLT-	21.31	18.53	15.16	13.66	13.49	11.88	6.47	4.39	-6.04

## ANGLE

20	-42.27	-42.88	-42.64	-44.42	-43.45	-46.01	-51.51	-54.74	-65.42
30	-37.64	-40.17	-40.67	-39.98	-40.73	-44.23	-51.99	-53.63	-66.56
40	-35.88	-38.19	-38.85	-36.71	-36.12	-41.79	-48.20	-48.16	-64.16
50	-36.25	-36.89	-36.00	-35.82	-36.34	-39.90	-46.11	-46.99	-64.88
60	-35.94	-33.73	-36.33	-37.49	-37.40	-44.04	-45.81	-51.20	-65.96
70	-34.77	-33.99	-35.29	-35.76	-35.64	-41.90	-41.18	-44.61	-63.62
80	-36.68	-31.58	-34.54	-34.04	-32.77	-39.84	-43.38	-48.05	-64.38

DLT-	21.31	18.53	15.16	13.66	13.49	11.88	6.47	4.39	-6.04
------	-------	-------	-------	-------	-------	-------	------	------	-------

VV	LENS-	1.01	-0.01	-1.20	-1.52	-0.41	-3.67	-8.54	-13.83	-37.87
	DLL-	20.44	17.74	14.30	12.31	12.44	10.08	5.98	2.95	-9.46
	DLT-	21.31	18.53	15.16	13.66	13.49	11.88	6.47	4.39	-6.04

## ANGLE

20	-30.68	-30.57	-31.93	-33.31	-33.04	-37.45	-42.61	-45.75	-59.93
30	-26.73	-25.30	-31.31	-29.30	-27.48	-31.35	-36.33	-40.15	-60.96
40	-25.41	-26.13	-25.77	-27.73	-26.30	-29.70	-32.47	-42.97	-61.56
50	-20.98	-24.35	-23.85	-17.41	-25.26	-27.52	-31.60	-31.88	-56.96
60	-16.60	-20.98	-23.93	-23.74	-20.58	-26.01	-32.91	-33.64	-54.85
70	-22.60	-19.17	-24.38	-20.27	-27.13	-32.19	-35.39	-29.54	-58.44
80	-17.38	-18.62	-20.17	-19.61	-20.72	-22.94	-33.08	-36.78	-59.36

DLT-	21.31	18.53	15.16	13.66	13.49	11.88	6.47	4.39	-6.04
------	-------	-------	-------	-------	-------	-------	------	------	-------

45

VH	LENS-	-28.34	-30.62	-28.48	-29.87	-29.65	-30.32	-32.66	-32.60	-52.57
	DLL-	20.44	17.74	14.30	12.31	12.44	10.08	5.98	2.95	-9.46
	DLT-	21.31	18.53	15.16	13.66	13.49	11.88	6.47	4.39	-6.04

ANGLE

20	-43.07	-43.68	-40.92	-46.85	-42.99	-46.83	-51.39	-56.16	-67.81
30	-38.28	-41.36	-39.73	-40.60	-40.24	-46.23	-51.83	-52.63	-66.09
40	-35.52	-37.90	-38.44	-37.06	-36.35	-41.35	-50.81	-48.93	-64.08
50	-36.25	-36.52	-36.09	-37.46	-36.57	-40.45	-51.03	-47.82	-63.08
60	-34.12	-35.38	-34.43	-38.47	-38.62	-44.15	-45.29	-52.82	-64.56
70	-35.20	-31.43	-34.56	-35.42	-37.69	-41.15	-43.59	-50.42	-64.39
80	-33.40	-32.86	-36.86	-36.36	-30.42	-40.93	-45.84	-47.32	-63.46
DLT-	21.31	18.53	15.16	13.66	13.49	11.88	6.47	4.39	-6.04

## SEA ICE DATA

## SPRING 1977 EXPERIMENT

DATE- MAY 18, 1977

SITE- 2 LOOK- 4

HH	LENS-	1.62	0.44	-1.46	-1.47	-0.75	-5.29	-11.48	-13.22	-37.42
	DLL-	20.44	17.74	14.30	12.31	12.44	10.08	5.98	2.95	-9.46
	DLT-	23.00	20.04	16.92	15.34	15.81	13.69	8.51	6.74	0.

## ANGLE

20	-31.64	-31.71	-34.53	-33.76	-30.23	-33.69	-36.81	-40.80	0.
30	-28.08	-28.46	-30.88	-30.33	-27.30	-29.91	-33.53	-36.64	0.
40	-24.63	-26.03	-28.17	-24.94	-23.36	-27.59	-33.20	-37.84	0.
50	-22.76	-21.45	-25.60	-25.91	-25.74	-25.89	-34.14	-36.79	0.
60	-22.19	-19.21	-22.50	-21.96	-22.35	-25.16	-33.04	-32.49	0.
70	-17.43	-17.83	-25.71	-21.64	-19.95	-23.77	-39.05	-31.61	0.
80	-21.29	-20.67	-22.73	-21.70	-23.75	-22.16	-30.42	-36.34	0.
DLT-	22.80	19.60	16.65	14.92	15.27	13.25	7.42	5.83	0.

HV	LENS-	-27.00	-25.75	-24.31	-24.06	-25.02	-27.28	-32.10	-31.41	-54.92
	DLL-	20.44	17.74	14.30	12.31	12.44	10.08	5.98	2.95	-9.46
	DLT-	22.80	19.60	16.65	14.92	15.27	13.25	7.42	5.83	0.

## ANGLE

20	-39.62	-39.89	-41.35	-40.73	-39.65	-45.98	-46.09	-52.90	0.
30	-36.75	-37.48	-37.87	-40.15	-37.86	-42.73	-46.63	-50.14	0.
40	-34.87	-36.69	-35.48	-39.93	-33.81	-42.42	-45.92	-45.74	0.
50	-32.13	-33.20	-35.74	-35.14	-35.94	-37.20	-44.62	-43.93	0.
60	-32.74	-32.40	-36.30	-35.14	-35.64	-36.88	-41.65	-46.22	0.
70	-32.47	-30.85	-35.63	-33.42	-32.00	-35.60	-39.81	-46.35	0.
80	-33.96	-32.34	-33.79	-33.36	-34.44	-35.60	-47.13	-39.56	0.
DLT-	22.80	19.60	16.65	14.92	15.27	13.25	7.42	5.83	0.

VV	LENS-	1.01	-0.01	-1.20	-1.52	-0.41	-3.67	-8.54	-13.83	-37.87
	DLL-	20.44	17.74	14.30	12.31	12.44	10.08	5.98	2.95	-9.46
	DLT-	22.80	19.60	16.65	14.92	15.27	13.25	7.42	5.83	0.

## ANGLE

20	-31.08	-30.80	-32.25	-33.15	-33.63	-35.52	-38.24	-43.19	0.
30	-27.04	-27.42	-30.28	-30.70	-25.29	-30.75	-37.91	-40.34	0.
40	-24.23	-26.34	-27.51	-25.23	-23.44	-27.06	-32.55	-38.23	0.
50	-24.59	-21.44	-25.36	-27.45	-24.85	-26.20	-35.73	-41.29	0.
60	-21.98	-19.70	-20.46	-21.93	-24.08	-26.70	-34.54	-32.96	0.
70	-18.37	-18.31	-24.14	-23.36	-22.03	-24.18	-34.38	-34.23	0.
80	-19.11	-21.90	-22.49	-18.55	-21.20	-25.28	-34.59	-39.82	0.
DLT-	22.80	19.60	16.65	14.92	15.27	13.25	7.42	5.83	0.

VH	LENS-	-28.34	-30.62	-28.48	-29.87	-29.65	-30.32	-32.66	-32.60	-52.57
	DLL-	20.44	17.74	14.30	12.31	12.44	10.08	5.98	2.95	-9.46
	DLT-	22.80	19.60	16.65	14.92	15.27	13.25	7.42	5.83	0.

ANGLE

20	-39.41	-39.38	-40.38	-40.55	-39.62	-45.21	-47.70	-55.49	0.	
30	-36.26	-38.46	-38.55	-40.55	-38.83	-44.35	-47.74	-51.59	0.	
40	-35.22	-36.59	-34.88	-38.55	-34.99	-42.28	-46.00	-47.30	0.	
50	-34.30	-34.59	-34.95	-36.52	-33.48	-36.48	-45.39	-46.68	0.	
60	-33.50	-32.20	-32.37	-33.92	-35.70	-42.24	-41.68	-48.63	0.	
70	-32.60	-31.98	-33.31	-34.99	-33.66	-35.76	-44.11	-44.83	0.	
80	-29.75	-31.87	-36.90	-36.14	-37.54	-33.46	-44.72	-44.60	0.	
	DLT-	22.80	19.60	16.65	14.92	15.27	13.25	7.42	5.83	0.

## SEA ICE DATA

SPRING 1977 EXPERIMENT

DATE- MAY 18, 1977

SITE- 2 LOOK- 5

HH	LENS-	1.62	0.44	-1.46	-1.47	-0.75	-5.29	-11.48	-13.22	-37.42
	DLL-	20.44	17.74	14.30	12.31	12.44	10.08	5.98	2.95	-9.46
	DLT-	22.23	19.16	15.89	14.38	14.69	12.59	7.33	5.48	0.

## ANGLE

20	-29.82	-30.65	-33.76	-32.72	-33.64	-34.20	-36.76	-42.79	0.
30	-27.48	-27.49	-30.29	-30.09	-29.88	-29.64	-37.69	-38.57	0.
40	-26.13	-28.39	-27.28	-26.19	-26.04	-28.21	-35.57	-36.80	0.
50	-23.64	-25.92	-26.66	-27.02	-27.67	-30.33	-31.89	-35.76	0.
60	-20.25	-23.38	-26.04	-27.18	-21.15	-25.53	-33.94	-34.37	0.
70	-20.15	-23.40	-23.38	-24.31	-22.67	-25.94	-26.27	-37.28	0.
80	-24.40	-20.24	-21.02	-20.68	-23.75	-25.36	-31.16	-32.15	0.

DLT-	22.23	19.16	15.89	14.38	14.69	12.59	7.33	5.48	0.
------	-------	-------	-------	-------	-------	-------	------	------	----

HV	LENS-	-27.00	-25.75	-24.31	-24.06	-25.02	-27.28	-32.10	-31.41	-54.92
	DLL-	20.44	17.74	14.30	12.31	12.44	10.08	5.98	2.95	-9.46
	DLT-	22.23	19.16	15.89	14.38	14.69	12.59	7.33	5.48	0.

## ANGLE

20	-43.09	-43.09	-42.52	-45.25	-42.84	-44.81	-47.89	-51.08	0.
30	-39.01	-39.74	-42.00	-41.15	-41.30	-42.45	-45.67	-48.78	0.
40	-36.63	-38.23	-38.77	-38.02	-38.09	-41.11	-43.72	-50.59	0.
50	-34.90	-35.98	-35.66	-38.53	-37.34	-41.34	-45.76	-48.38	0.
60	-37.29	-34.46	-34.21	-38.13	-33.64	-40.47	-45.87	-47.50	0.
70	-35.64	-35.35	-37.06	-38.79	-37.48	-41.49	-45.45	-47.77	0.
80	-31.27	-34.06	-36.19	-32.77	-33.52	-41.59	-43.91	-44.66	0.

DLT-	22.23	19.16	15.89	14.38	14.69	12.59	7.33	5.48	0.
------	-------	-------	-------	-------	-------	-------	------	------	----

VV	LENS-	1.01	-0.01	-1.20	-1.52	-0.41	-3.67	-8.54	-13.83	-37.87
	DLL-	20.44	17.74	14.30	12.31	12.44	10.08	5.98	2.95	-9.46
	DLT-	22.23	19.16	15.89	14.38	14.69	12.59	7.33	5.48	0.

## ANGLE

20	-31.90	-32.01	-32.69	-32.56	-32.45	-34.70	-38.41	-41.62	0.
30	-27.66	-27.40	-31.43	-28.93	-29.64	-30.03	-36.81	-41.00	0.
40	-26.67	-26.35	-25.82	-27.54	-27.31	-30.39	-36.16	-39.98	0.
50	-24.69	-26.45	-26.66	-30.28	-29.18	-31.35	-34.56	-33.47	0.
60	-20.07	-23.27	-25.59	-26.37	-20.61	-26.49	-31.16	-32.83	0.
70	-19.22	-20.15	-21.69	-22.64	-23.03	-22.44	-31.15	-40.24	0.
80	-24.86	-19.98	-22.00	-19.32	-27.13	-25.56	-32.37	-32.13	0.

DLT-	22.23	19.16	15.89	14.38	14.69	12.59	7.33	5.48	0.
------	-------	-------	-------	-------	-------	-------	------	------	----

VH LENS- -28.34 -30.62 -28.48 -29.87 -29.65 -30.32 -32.66 -32.60 -52.57  
DLL- 20.44 17.74 14.30 12.31 12.44 10.08 5.98 2.95 -9.46

DLT- 22.23 19.16 15.89 14.38 14.69 12.59 7.33 5.48 0.

ANGLE

20 -42.85 -43.27 -42.96 -45.83 -44.85 -45.29 -51.51 -52.98 0.

30 -39.38 -40.02 -40.70 -41.23 -41.18 -42.59 -46.42 -50.41 0.

40 -36.48 -37.90 -38.34 -37.53 -37.49 -41.42 -46.44 -51.68 0.

50 -35.43 -36.98 -37.71 -36.58 -36.74 -42.03 -46.98 -48.00 0.

60 -38.37 -35.39 -36.74 -35.81 -35.33 -42.19 -47.48 -47.95 0.

70 -37.49 -34.95 -37.12 -40.17 -32.56 -44.31 -45.98 -50.07 0.

80 -35.62 -36.70 -37.73 -33.80 -34.13 -36.83 -45.12 -47.35 0.

DLT- 22.23 19.16 15.89 14.38 14.69 12.59 7.33 5.48 0.

SEA ICE DATA      SPRING 1977 EXPERIMENT

DATE- MAY 18, 1977      SITE- 2    LOOK- 6

HH    LENS-    1.62    0.44    -1.46    -1.47    -0.75    -5.29    -11.48    -13.22    -37.42  
       DLL-    20.44    17.74    14.30    12.31    12.44    10.08    5.98    2.95    -9.46  
       DLT-    22.22    19.65    16.48    14.85    14.70    12.87    7.03    5.50    0.

ANGLE

20    -28.20    -27.40    -29.83    -28.09    -25.14    -31.31    -34.43    -37.28    0.  
 30    -26.26    -22.87    -27.84    -27.75    -27.33    -29.38    -33.72    -38.34    0.  
 40    -24.72    -28.82    -25.63    -26.81    -26.63    -30.89    -32.47    -32.86    0.  
 50    -22.45    -23.90    -23.98    -26.35    -27.06    -28.37    -31.31    -34.71    0.  
 60    -21.02    -22.14    -25.11    -23.14    -24.72    -26.38    -33.07    -35.65    0.  
 70    -18.84    -23.43    -22.63    -31.25    -24.35    -25.03    -34.35    -34.05    0.  
 80    -18.86    -17.79    -22.96    -18.18    -18.39    -26.17    -29.53    -31.78    0.  
       DLT-    22.22    19.65    16.48    14.85    14.70    12.87    7.03    5.50    0.

HV    LENS-    -27.00    -25.75    -24.31    -24.06    -25.02    -27.28    -32.10    -31.41    -54.92  
       DLL-    20.44    17.74    14.30    12.31    12.44    10.08    5.98    2.95    -9.46  
       DLT-    22.22    19.65    16.48    14.85    14.70    12.87    7.03    5.50    0.

ANGLE

20    -39.50    -39.33    -40.29    -40.17    -40.96    -42.27    -46.03    -49.49    0.  
 30    -37.67    -39.59    -38.71    -38.14    -41.49    -41.48    -43.08    -47.51    0.  
 40    -36.67    -33.19    -36.15    -35.00    -37.38    -40.31    -41.40    -43.27    0.  
 50    -34.45    -33.39    -36.20    -33.49    -33.20    -40.32    -43.60    -48.63    0.  
 60    -36.61    -34.93    -35.18    -35.32    -34.09    -35.97    -42.26    -46.11    0.  
 70    -32.41    -37.02    -35.93    -34.31    -35.25    -41.83    -44.03    -43.76    0.  
 80    -33.50    -30.68    -33.09    -36.66    -35.32    -37.39    -43.11    -44.77    0.  
       DLT-    22.22    19.65    16.48    14.85    14.70    12.87    7.03    5.50    0.

VV    LENS-    1.01    -0.01    -1.20    -1.52    -0.41    -3.67    -8.54    -13.83    -37.87  
       DLL-    20.44    17.74    14.30    12.31    12.44    10.08    5.98    2.95    -9.46  
       DLT-    0.       0.       0.       0.       0.       0.       0.       0.       0.

ANGLE

20    0.       0.       0.       0.       0.       0.       0.       0.       0.  
 30    0.       0.       0.       0.       0.       0.       0.       0.       0.  
 40    0.       0.       0.       0.       0.       0.       0.       0.       0.  
 50    0.       0.       0.       0.       0.       0.       0.       0.       0.  
 60    0.       0.       0.       0.       0.       0.       0.       0.       0.  
 70    0.       0.       0.       0.       0.       0.       0.       0.       0.  
 80    0.       0.       0.       0.       0.       0.       0.       0.       0.  
       DLT-    0.       0.       0.       0.       0.       0.       0.       0.       0.

VH	LENS-	-28.34	-30.62	-28.48	-29.87	-29.65	-30.32	-32.66	-32.60	-52.57
	DLL-	20.44	17.74	14.30	12.31	12.44	10.08	5.98	2.95	-9.46
	DLT-	0.	0.	0.	0.	0.	0.	0.	0.	0.
	ANGLE									
	2C	0.	0.	0.	0.	0.	0.	0.	0.	0.
	3C	0.	0.	0.	0.	0.	0.	0.	0.	0.
	40	0.	0.	0.	0.	0.	0.	0.	0.	0.
	50	0.	0.	0.	0.	0.	0.	0.	0.	0.
	60	0.	0.	0.	0.	0.	0.	0.	0.	0.
	70	0.	0.	0.	0.	0.	0.	0.	0.	0.
	80	0.	0.	0.	0.	0.	0.	0.	0.	0.
	DLT-	0.	0.	0.	0.	0.	0.	0.	0.	0.

## SEA ICE DATA

SPRING 1977 EXPERIMENT

DATE- MAY 19, 1977

SITE- 3 LOOK- 1

HH	LENS-	-13.62	-11.80	-10.21	-11.24	-11.62	-11.51	-12.52	-16.22	-24.11
	DLL-	13.09	12.33	12.32	7.44	5.38	4.98	-0.29	-6.87	-12.35
	DLT-	14.71	13.91	13.83	10.02	8.76	8.45	3.54	-4.14	-7.78

## ANGLE

20	-45.41	-41.87	-44.67	-42.94	-43.21	-43.48	-44.09	-47.65	-51.85
30	-49.58	-46.88	-41.46	-48.12	-41.23	-44.14	-49.22	-48.70	-51.74
40	-53.24	-48.15	-44.82	-45.56	-46.97	-42.32	-47.80	-49.66	-48.93
50	-49.56	-45.20	-51.29	-48.17	-49.34	-45.98	-46.00	-50.25	-49.43
60	-50.21	-43.09	-46.45	-47.26	-43.80	-40.73	-47.19	-48.64	-51.75
70	-40.38	-42.63	-41.98	-41.43	-43.43	-42.34	-43.56	-45.59	-49.52
80	-39.98	-46.72	-45.58	-42.33	-41.54	-42.22	-51.00	-47.35	-53.51

DLT-	14.31	13.51	13.45	9.38	7.92	7.58	2.58	-4.82	-8.92
------	-------	-------	-------	------	------	------	------	-------	-------

HV	LENS-	-41.35	-41.58	-38.97	-40.44	-38.88	-38.07	-40.56	-45.64	-54.89
	DLL-	13.09	12.33	12.32	7.44	5.38	4.98	-0.29	-6.87	-12.35
	DLT-	14.31	13.51	13.45	9.38	7.92	7.58	2.58	-4.82	-8.92

## ANGLE

20	-56.77	-54.65	-53.24	-55.16	-53.42	-54.63	-52.08	-59.39	-61.85
30	-59.17	-56.33	-55.76	-59.36	-56.49	-54.01	-55.58	-53.40	-62.53
40	-60.27	-56.84	-58.86	-61.28	-63.05	-55.78	-54.45	-58.40	-61.60
50	-61.62	-62.69	-55.39	-54.86	-61.09	-61.81	-56.44	-56.46	-61.23
60	-56.12	-58.58	-56.41	-55.81	-57.67	-62.11	-51.43	-53.21	-60.41
70	-57.84	-57.62	-55.18	-57.20	-57.46	-59.23	-53.54	-46.52	-57.49
80	-57.46	-54.89	-55.33	-46.87	-55.10	-50.83	-53.18	-50.27	-54.91

DLT-	13.90	13.12	13.08	8.73	7.07	6.72	1.63	-5.50	-10.07
------	-------	-------	-------	------	------	------	------	-------	--------

VV	LENS-	-14.35	-12.83	-11.51	-12.72	-13.48	-13.71	-15.18	-21.91	-25.02
	DLL-	13.09	12.33	12.32	7.44	5.38	4.98	-0.29	-6.87	-12.35
	DLT-	13.90	13.12	13.08	8.73	7.07	6.72	1.63	-5.50	-10.07

## ANGLE

20	-44.44	-44.58	-46.01	-45.83	-45.90	-47.45	-46.94	-46.16	-58.37
30	-49.39	-49.10	-44.92	-47.32	-43.41	-44.91	-43.96	-50.85	-55.84
40	-52.09	-47.56	-50.10	-48.09	-47.76	-42.58	-45.85	-56.63	-58.68
50	-47.76	-49.75	-46.97	-55.07	-50.53	-42.97	-43.69	-55.17	-54.27
60	-46.91	-44.88	-43.50	-52.68	-43.74	-44.99	-52.80	-45.28	-54.11
70	-39.90	-41.87	-42.29	-42.51	-43.31	-44.89	-44.32	-51.68	-52.26
80	-38.29	-46.98	-45.04	-44.70	-48.53	-46.07	-46.55	-51.71	-61.99

DLT-	13.50	12.73	12.70	8.09	6.23	5.85	0.67	-6.19	-11.21
------	-------	-------	-------	------	------	------	------	-------	--------

VH LENS- -44.17 -40.98 -39.72 -41.71 -39.57 -40.16 -33.93 -40.71 -43.51  
DLL- 13.09 12.33 12.32 7.44 5.38 4.98 -0.29 -6.87 -12.35  
DLT- 13.50 12.73 12.70 8.09 6.23 5.85 0.67 -6.19 -11.21

ANGLE

20 -55.48 -55.27 -52.30 -55.96 -54.17 -52.86 -55.62 -56.57 -59.33  
30 -59.42 -55.44 -54.66 -58.37 -57.02 -54.72 -56.25 -56.34 -59.70  
40 -60.74 -56.54 -57.69 -59.40 -60.61 -54.31 -55.45 -56.29 -60.00  
50 -59.95 -59.17 -56.22 -54.73 -56.94 -59.09 -57.54 -56.02 -60.51  
60 -57.08 -61.81 -56.59 -55.18 -58.82 -59.23 -51.28 -54.59 -58.89  
70 -55.49 -53.95 -55.29 -56.99 -58.97 -58.68 -58.10 -56.54 -60.85  
80 -58.92 -56.45 -52.79 -53.85 -51.41 -54.94 -55.04 -54.50 -61.60  
DLT- 13.09 12.33 12.32 7.44 5.38 4.98 -0.29 -6.87 -12.35

54

## SEA ICE DATA SPRING 1977 EXPERIMENT

DATE- MAY 19, 1977 SITE- 3 LOOK- 2

HH	LENS-	-13.62	-11.80	-10.21	-11.24	-11.62	-11.51	-12.52	-16.22	-24.11
	DLL-	13.09	12.33	12.32	7.44	5.38	4.98	-0.29	-6.87	-12.35
	DLT-	21.15	19.80	17.05	13.94	12.60	12.62	12.09	8.36	5.31

## ANGLE

20	-38.56	-36.03	-35.87	-36.34	-36.07	-37.03	-34.59	-35.90	-40.04
30	-34.62	-33.41	-32.87	-33.96	-33.53	-31.62	-30.72	-33.87	-36.79
40	-32.75	-32.97	-32.49	-30.72	-33.70	-29.42	-28.29	-30.86	-35.88
50	-32.61	-31.13	-30.11	-34.08	-32.86	-29.86	-31.28	-34.67	-32.59
60	-29.81	-30.43	-32.30	-32.12	-28.33	-27.65	-32.42	-36.22	-37.22
70	-26.69	-24.52	-32.07	-30.96	-34.18	-29.98	-28.53	-33.90	-35.85
80	-19.69	-20.43	-22.19	-22.91	-21.54	-23.13	-22.47	-25.23	-24.54

DLT-	20.27	18.61	15.94	13.06	11.90	12.16	11.33	8.11	5.25
------	-------	-------	-------	-------	-------	-------	-------	------	------

HV	LENS-	-41.35	-41.58	-38.97	-40.44	-38.88	-38.07	-40.56	-45.64	-54.89
	DLL-	13.09	12.33	12.32	7.44	5.38	4.98	-0.29	-6.87	-12.35
	DLT-	20.27	18.61	15.94	13.06	11.90	12.16	11.33	8.11	5.25

## ANGLE

20	-46.19	-46.34	-44.38	-44.78	-48.06	-43.61	-46.10	-45.90	-51.28
30	-46.32	-45.61	-43.89	-43.17	-43.73	-42.73	-42.27	-44.55	-47.91
40	-43.73	-43.77	-44.24	-43.29	-44.36	-41.96	-43.07	-43.63	-46.04
50	-42.94	-44.59	-42.59	-41.87	-47.74	-42.52	-39.53	-46.25	-47.65
60	-44.72	-43.06	-41.62	-43.74	-46.63	-41.31	-38.50	-40.44	-50.47
70	-44.14	-45.85	-44.24	-43.12	-39.88	-39.16	-40.51	-40.04	-44.27
80	-37.64	-41.04	-38.23	-38.90	-42.73	-46.21	-41.44	-41.14	-41.48

DLT-	19.39	17.41	14.83	12.17	11.19	11.70	10.57	7.85	5.19
------	-------	-------	-------	-------	-------	-------	-------	------	------

VV	LENS-	-14.35	-12.83	-11.51	-12.72	-13.48	-13.71	-15.18	-21.91	-25.02
	DLL-	13.09	12.33	12.32	7.44	5.38	4.98	-0.29	-6.87	-12.35
	DLT-	19.39	17.41	14.83	12.17	11.19	11.70	10.57	7.85	5.19

## ANGLE

20	-37.07	-35.81	-34.29	-36.10	-33.84	-31.95	-32.04	-34.89	-40.77
30	-35.10	-34.38	-35.07	-35.76	-35.04	-32.81	-31.80	-33.95	-35.95
40	-33.38	-34.39	-34.42	-33.80	-36.49	-31.57	-33.28	-33.56	-37.32
50	-33.72	-30.74	-31.45	-35.70	-36.04	-33.01	-30.91	-34.68	-39.55
60	-31.04	-31.86	-33.65	-32.30	-29.35	-31.52	-35.29	-34.34	-38.86
70	-30.99	-28.27	-34.48	-38.68	-33.54	-26.53	-27.07	-34.70	-37.14
80	-19.60	-20.14	-21.21	-21.00	-18.76	-18.19	-21.44	-26.57	-26.34

DLT-	19.39	17.41	14.83	12.17	11.19	11.70	10.57	7.85	5.19
------	-------	-------	-------	-------	-------	-------	-------	------	------

55

VH	LENS-	-44.17	-40.98	-39.72	-41.71	-39.57	-40.16	-33.93	-40.71	-43.51
	DLL-	13.09	12.33	12.32	7.44	5.38	4.98	-0.29	-6.87	-12.35
	DLT-	19.39	17.41	14.83	12.17	11.19	11.70	10.57	7.85	5.19

ANGLE

20	-48.54	-46.85	-47.90	-41.67	-43.89	-51.93	-54.32	-53.47	-53.17
30	-50.23	-49.13	-50.99	-43.24	-47.27	-47.58	-47.62	-48.50	-51.58
40	-43.67	-43.70	-45.39	-42.05	-44.17	-43.69	-44.39	-46.21	-46.96
50	-39.87	-41.41	-43.62	-40.84	-42.19	-50.08	-50.63	-52.88	-51.64
60	-44.08	-44.48	-43.96	-42.58	-50.42	-43.58	-42.42	-41.71	-48.58
70	-42.48	-41.69	-45.79	-42.40	-39.43	-38.63	-41.33	-40.57	-46.30
80	-39.59	-39.66	-36.98	-39.66	-39.09	-38.83	-44.16	-47.77	-46.38
DLT-	19.39	17.41	14.83	12.17	11.19	11.70	10.57	7.85	5.19

## SEA ICE DATA SPRING 1977 EXPERIMENT

DATE- MAY 20, 1977 SITE- 3 LOOK- 3

HH	LENS-	-13.62	-11.80	-10.21	-11.24	-11.62	-11.51	-12.52	-16.22	-24.11
	DLL-	13.09	12.33	12.32	7.44	5.38	4.98	-0.29	-6.87	-12.35
	DLT-	20.40	19.33	16.46	13.10	12.02	12.22	11.96	7.96	3.16

## ANGLE

20	-37.18	-33.39	-34.58	-37.54	-37.20	-33.80	-34.05	-38.17	-40.16
30	-34.25	-33.11	-30.67	-33.31	-33.06	-32.92	-33.34	-34.03	-40.63
40	-30.26	-33.80	-32.41	-34.62	-33.58	-31.02	-27.78	-34.20	-39.79
50	-32.50	-33.96	-30.87	-32.20	-31.00	-30.89	-29.79	-33.29	-43.76
60	-32.06	-27.43	-29.38	-28.99	-37.84	-35.28	-33.88	-36.11	-39.60
70	-28.51	-27.32	-29.61	-27.63	-27.12	-23.42	-32.17	-33.18	-31.96
80	-24.81	-25.22	-26.07	-25.43	-34.29	-27.69	-29.28	-31.55	-40.42

DLT-	20.67	19.44	16.68	13.26	12.33	12.50	11.91	7.65	2.75
------	-------	-------	-------	-------	-------	-------	-------	------	------

HV	LENS-	-41.35	-41.58	-38.97	-40.44	-38.88	-38.07	-40.56	-45.64	-54.89
	DLL-	13.09	12.33	12.32	7.44	5.38	4.98	-0.29	-6.87	-12.35
	DLT-	20.67	19.44	16.68	13.26	12.33	12.50	11.91	7.65	2.75

## ANGLE

20	-51.46	-49.20	-49.80	-44.07	-49.41	-46.10	-49.38	-52.77	-53.43
30	-48.12	-49.91	-49.54	-42.11	-46.68	-42.96	-44.04	-50.43	-52.75
40	-47.20	-44.25	-44.46	-42.79	-44.49	-45.39	-46.22	-47.88	-51.26
50	-45.22	-44.93	-42.09	-42.28	-45.26	-44.10	-38.88	-46.29	-53.39
60	-40.66	-45.09	-46.17	-41.34	-46.52	-43.98	-44.21	-49.66	-51.24
70	-42.98	-41.94	-43.82	-39.05	-42.15	-40.00	-39.71	-43.75	-51.34
80	-43.90	-46.79	-42.37	-38.67	-38.45	-43.94	-40.18	-42.71	-49.65

DLT-	20.94	19.56	16.89	13.43	12.64	12.78	11.85	7.34	2.34
------	-------	-------	-------	-------	-------	-------	-------	------	------

VV	LENS-	-14.35	-12.83	-11.51	-12.72	-13.48	-13.71	-15.18	-21.91	-25.02
	DLL-	13.09	12.33	12.32	7.44	5.38	4.98	-0.29	-6.87	-12.35
	DLT-	20.94	19.56	16.89	13.43	12.64	12.78	11.85	7.34	2.34

## ANGLE

20	-37.17	-34.59	-36.79	-37.80	-36.25	-33.30	-34.54	-39.08	-44.99
30	-33.87	-35.67	-32.50	-34.73	-35.78	-33.19	-32.76	-37.60	-41.98
40	-32.98	-31.19	-33.01	-32.72	-34.07	-29.38	-31.11	-36.59	-44.52
50	-31.83	-33.03	-31.83	-29.62	-32.82	-29.57	-31.53	-36.28	-41.94
60	-33.20	-29.46	-29.79	-30.84	-38.50	-33.97	-31.68	-35.32	-43.02
70	-27.64	-24.48	-29.30	-28.24	-27.68	-27.49	-30.04	-30.39	-33.86
80	-24.78	-23.17	-21.05	-29.06	-33.21	-25.36	-24.63	-34.48	-37.01

DLT-	20.94	19.56	16.89	13.43	12.64	12.78	11.85	7.34	2.34
------	-------	-------	-------	-------	-------	-------	-------	------	------

57

VH	LENS-	-44.17	-40.98	-39.72	-41.71	-39.57	-40.16	-33.93	-40.71	-43.51
	DLL-	13.09	12.33	12.32	7.44	5.38	4.98	-0.29	-6.87	-12.35
	DLT-	20.94	19.56	16.89	13.43	12.64	12.78	11.85	7.34	2.34

ANGLE

20	-51.98	-50.21	-50.15	-41.73	-49.90	-47.04	-50.72	-52.74	-55.18	
30	-49.81	-50.45	-47.60	-40.71	-47.20	-42.96	-44.89	-50.22	-54.25	
40	-45.55	-44.63	-44.79	-42.45	-42.41	-45.03	-46.69	-48.80	-52.33	
50	-46.18	-43.00	-42.07	-41.88	-47.49	-44.57	-43.94	-45.67	-52.04	
60	-43.60	-47.64	-45.13	-40.82	-45.29	-45.65	-43.92	-51.12	-51.60	
70	-45.39	-45.88	-40.12	-38.97	-44.35	-41.37	-42.14	-45.92	-53.81	
80	-41.94	-47.95	-40.25	-40.79	-42.03	-41.94	-42.73	-45.40	-48.09	
	DLT-	20.94	19.56	16.89	13.43	12.64	12.78	11.85	7.34	2.34

## SEA ICE DATA

SPRING 1977 EXPERIMENT

DATE- MAY 20, 1977

SITE- 3 LOOK- 4

HH	LENS-	1.81	1.97	0.48	-0.29	-0.64	0.37	-0.34	-5.80	-12.05
	DLL-	20.81	19.42	16.81	13.27	12.30	12.33	11.52	6.69	1.29
	DLT-	22.06	20.66	18.24	14.90	14.37	14.71	13.69	9.52	4.85

## ANGLE

20	-38.06	-35.72	-34.03	-35.60	-34.23	-34.68	-32.81	-37.36	-44.26
30	-34.09	-34.89	-33.76	-35.61	-30.90	-29.78	-33.01	-35.79	-40.70
40	-31.51	-30.93	-37.03	-34.03	-33.01	-32.89	-27.22	-36.89	-37.92
50	-34.86	-29.83	-32.52	-32.37	-31.25	-30.57	-30.57	-30.56	-40.74
60	-34.08	-29.32	-27.50	-31.08	-28.69	-26.00	-28.76	-28.20	-34.89
70	-24.48	-27.23	-24.59	-27.85	-25.47	-26.22	-29.80	-30.26	-34.13
80	-30.03	-22.08	-22.01	-25.67	-20.13	-15.94	-24.85	-24.77	-32.70

DLT-	22.13	20.84	18.35	14.98	14.36	14.56	13.67	9.42	4.43
------	-------	-------	-------	-------	-------	-------	-------	------	------

HV	LENS-	-25.73	-28.25	-27.74	-28.75	-28.64	-27.63	-27.66	-33.16	-35.71
	DLL-	20.81	19.42	16.81	13.27	12.30	12.33	11.52	6.69	1.29
	DLT-	22.13	20.84	18.35	14.98	14.36	14.56	13.67	9.42	4.43

## ANGLE

20	-49.81	-48.95	-47.34	-44.38	-47.15	-46.93	-45.33	-45.63	-50.25
30	-45.98	-47.43	-47.67	-44.10	-44.13	-42.44	-47.18	-43.49	-48.17
40	-47.61	-43.03	-41.10	-46.21	-44.19	-44.93	-44.69	-47.26	-47.64
50	-46.42	-43.60	-41.08	-42.33	-42.15	-40.16	-43.15	-46.83	-48.28
60	-43.67	-43.89	-40.74	-40.96	-42.41	-44.09	-41.83	-45.25	-46.70
70	-47.03	-41.53	-39.72	-40.95	-42.08	-44.29	-40.30	-46.59	-48.33
80	-40.27	-43.66	-39.72	-42.30	-44.88	-36.54	-34.76	-39.55	-49.70

DLT-	22.19	21.01	18.45	15.05	14.34	14.40	13.65	9.32	4.00
------	-------	-------	-------	-------	-------	-------	-------	------	------

VV	LENS-	-0.35	-0.14	-0.91	-2.94	-2.88	-3.03	-4.97	-10.79	-16.30
	DLL-	20.81	19.42	16.81	13.27	12.30	12.33	11.52	6.69	1.29
	DLT-	22.19	21.01	18.45	15.05	14.34	14.40	13.65	9.32	4.00

## ANGLE

20	-35.65	-37.25	-33.32	-35.34	-35.32	-35.24	-33.85	-37.75	-44.41
30	-35.60	-32.45	-32.33	-32.81	-31.69	-31.07	-32.07	-35.24	-38.01
40	-31.45	-32.52	-34.27	-31.39	-31.22	-33.78	-32.86	-37.21	-39.75
50	-35.17	-27.90	-32.70	-31.07	-34.15	-27.21	-30.43	-29.52	-39.45
60	-34.48	-31.31	-28.33	-31.50	-29.09	-26.91	-27.32	-30.86	-36.11
70	-28.62	-26.28	-24.64	-29.62	-25.67	-25.77	-27.07	-31.04	-36.00
80	-26.49	-22.92	-20.85	-29.64	-22.49	-17.98	-24.01	-24.00	-28.96

DLT-	22.01	20.82	18.27	14.85	14.07	14.23	13.38	9.01	3.68
------	-------	-------	-------	-------	-------	-------	-------	------	------

VH	LENS-	-27.42	-30.68	-28.43	-31.61	-29.97	-30.12	-26.82	-34.33	-41.29
	DLL-	20.81	19.42	16.81	13.27	12.30	12.33	11.52	6.69	1.29
	DLT-	22.01	20.82	18.27	14.85	14.07	14.23	13.38	9.01	3.68

ANGLE

20	-47.95	-49.59	-47.66	-44.33	-47.36	-46.83	-46.07	-50.77	-54.78
30	-47.01	-46.92	-48.03	-44.36	-44.84	-43.99	-48.25	-45.39	-52.09
40	-46.57	-43.09	-41.73	-44.80	-43.80	-44.05	-45.74	-50.77	-53.80
50	-45.67	-42.00	-41.71	-41.97	-43.63	-39.79	-44.03	-49.49	-51.14
60	-44.00	-47.53	-40.25	-39.38	-46.71	-42.81	-50.95	-50.40	-50.18
70	-44.46	-41.02	-39.84	-43.94	-40.53	-45.15	-43.66	-48.03	-48.40
80	-43.08	-48.19	-36.89	-41.88	-41.45	-40.84	-42.21	-42.46	-50.15
DLT-	21.82	20.62	18.08	14.65	13.80	14.05	13.12	8.69	3.36

60

## SEA ICE DATA

## SPRING 1977 EXPERIMENT

DATE- MAY 20, 1977

SITE- 3 LOOK- 5

HH	LENS-	1.81	1.97	0.48	-0.29	-0.64	0.37	-0.34	-5.80	-12.05
	DLL-	20.81	19.42	16.81	13.27	12.30	12.33	11.52	6.69	1.29
	DLT-	22.56	21.41	18.86	15.51	15.10	15.35	14.33	10.06	5.72

## ANGLE

20	-39.60	-36.05	-38.77	-37.70	-34.10	-32.65	-36.92	-35.74	-40.80
30	-34.83	-35.71	-32.77	-34.52	-30.24	-27.33	-33.34	-37.04	-42.37
40	-34.24	-34.49	-37.82	-34.44	-29.64	-30.46	-34.34	-34.81	-38.94
50	-28.70	-30.08	-30.56	-34.14	-31.05	-27.18	-29.74	-39.54	-37.46
60	-29.47	-26.98	-25.71	-26.55	-29.54	-29.62	-28.24	-36.05	-38.56
70	-30.82	-27.28	-26.30	-26.23	-24.09	-24.18	-25.18	-29.20	-34.22
80	-18.35	-19.91	-19.76	-21.75	-19.59	-27.89	-27.32	-25.56	-34.66
DLT-	22.53	21.33	18.80	15.46	14.95	15.22	14.22	9.83	5.33

HV	LENS-	-25.73	-28.25	-27.74	-28.75	-28.64	-27.63	-27.66	-33.16	-35.71
	DLL-	20.81	19.42	16.81	13.27	12.30	12.33	11.52	6.69	1.29
	DLT-	22.53	21.33	18.80	15.46	14.95	15.22	14.22	9.83	5.33

## ANGLE

20	-51.38	-51.87	-49.25	-45.70	-48.40	-47.79	-47.48	-50.34	-50.64
30	-50.90	-48.69	-43.63	-44.88	-43.51	-43.21	-48.63	-48.57	-48.66
40	-51.33	-50.82	-46.03	-44.82	-43.08	-43.61	-39.89	-47.58	-48.38
50	-47.04	-44.58	-43.50	-42.36	-44.02	-40.22	-39.01	-47.73	-49.32
60	-42.75	-46.07	-47.62	-42.33	-44.39	-40.13	-40.69	-44.83	-47.63
70	-43.94	-40.42	-40.74	-41.34	-45.01	-41.83	-42.47	-49.56	-46.21
80	-47.16	-42.08	-38.25	-39.43	-38.63	-43.71	-40.63	-44.45	-47.40
DLT-	22.50	21.25	18.74	15.40	14.80	15.09	14.10	9.59	4.94

VV	LENS-	-0.35	-0.14	-0.91	-2.94	-2.88	-3.03	-4.97	-10.79	-16.30
	DLL-	20.81	19.42	16.81	13.27	12.30	12.33	11.52	6.69	1.29
	DLT-	22.50	21.25	18.74	15.40	14.80	15.09	14.10	9.59	4.94

## ANGLE

20	-40.26	-38.44	-38.76	-37.59	-35.35	-35.86	-37.08	-37.82	-45.06
30	-35.66	-36.55	-33.67	-32.29	-33.55	-30.69	-37.65	-39.94	-43.55
40	-35.47	-33.79	-38.49	-36.41	-33.38	-30.40	-36.47	-35.45	-43.40
50	-30.06	-31.52	-30.57	-33.04	-32.30	-28.84	-31.82	-37.68	-36.75
60	-30.18	-27.92	-28.06	-28.01	-31.31	-31.30	-28.95	-36.55	-38.61
70	-30.26	-27.87	-24.77	-27.84	-24.56	-25.17	-27.73	-32.43	-35.67
80	-19.63	-18.56	-24.17	-20.38	-20.06	-29.12	-25.90	-28.00	-38.78
DLT-	22.37	21.13	18.62	15.23	14.58	14.87	13.87	9.27	4.49

VH	LENS-	-27.42	-30.68	-28.43	-31.61	-29.97	-30.12	-26.82	-34.33	-41.29
	DLL-	20.81	19.42	16.81	13.27	12.30	12.33	11.52	6.69	1.29
	DLT-	22.37	21.13	18.62	15.23	14.58	14.87	13.87	9.27	4.49

ANGLE

20	-52.19	-50.41	-49.89	-45.70	-50.04	-47.47	-48.23	-52.49	-57.00
30	-49.09	-48.49	-43.78	-43.79	-45.74	-45.03	-47.56	-48.42	-53.28
40	-50.39	-50.97	-45.56	-44.26	-43.30	-44.21	-40.48	-47.80	-54.46
50	-44.15	-44.32	-44.15	-41.70	-46.51	-40.71	-38.24	-48.02	-52.70
60	-42.19	-45.23	-49.30	-43.21	-45.21	-41.63	-43.41	-45.50	-50.93
70	-42.24	-40.84	-40.41	-42.50	-48.46	-43.68	-45.22	-46.97	-48.26
80	-42.90	-45.74	-40.75	-40.36	-40.65	-45.51	-39.64	-42.90	-49.24
DLT-	22.23	21.02	18.49	15.06	14.36	14.65	13.63	8.94	4.04

## SEA ICE DATA

SPRING 1977 EXPERIMENT

DATE- MAY 21, 1977

SITE- 3 LOOK- 5

HH	LENS-	1.81	1.97	0.48	-0.29	-0.64	0.37	-0.34	-5.80	-12.05
	DLL-	20.81	19.42	16.81	13.27	12.30	12.33	11.52	6.69	1.29
	DLT-	23.38	22.23	19.85	16.53	16.07	16.51	15.65	11.84	6.96

## ANGLE

20	-34.89	-35.16	-35.11	-39.83	-32.52	-31.86	-35.27	-38.31	-42.79
30	-35.07	-33.75	-31.15	-31.58	-30.45	-31.68	-34.40	-36.90	-39.88
40	-31.75	-32.05	-32.77	-34.88	-29.92	-27.13	-30.49	-24.91	-40.99
50	-28.68	-33.99	-31.37	-29.43	-29.61	-31.37	-30.59	-35.76	-39.55
60	-25.06	-25.54	-26.02	-25.36	-34.77	-31.30	-29.33	-31.81	-35.65
70	-28.54	-24.77	-23.66	-33.74	-21.43	-20.90	-21.46	-29.41	-35.38
80	-18.04	-17.71	-20.03	-15.35	-21.67	-21.01	-25.95	-24.49	-28.73

DLT-	23.38	22.23	19.67	16.41	15.98	16.28	15.41	11.51	6.44
------	-------	-------	-------	-------	-------	-------	-------	-------	------

HV	LENS-	-25.73	-28.25	-27.74	-28.75	-28.64	-27.63	-27.66	-33.16	-35.71
	DLL-	20.81	19.42	16.81	13.27	12.30	12.33	11.52	6.69	1.29
	DLT-	23.38	22.23	19.67	16.41	15.98	16.28	15.41	11.51	6.44

## ANGLE

20	-52.81	-51.63	-48.19	-46.16	-49.94	-48.36	-47.14	-48.71	-51.00
30	-49.85	-46.64	-43.16	-44.73	-44.83	-43.94	-46.45	-48.75	-47.48
40	-48.06	-47.63	-46.76	-43.94	-42.44	-42.90	-45.56	-52.53	-50.18
50	-46.35	-46.34	-41.17	-46.10	-46.23	-42.48	-43.38	-46.63	-48.65
60	-47.93	-43.40	-41.72	-41.43	-42.59	-40.62	-44.13	-46.24	-51.24
70	-43.35	-44.52	-39.34	-44.04	-42.49	-44.33	-44.39	-49.32	-49.87
80	-41.53	-46.16	-41.71	-35.27	-41.51	-34.74	-42.70	-46.26	-50.12

DLT-	23.37	22.22	19.50	16.30	15.89	16.04	15.17	11.18	5.91
------	-------	-------	-------	-------	-------	-------	-------	-------	------

VV	LENS-	-0.35	-0.14	-0.91	-2.94	-2.88	-3.03	-4.97	-10.79	-16.30
	DLL-	20.81	19.42	16.81	13.27	12.30	12.33	11.52	6.69	1.29
	DLT-	23.13	21.99	19.51	16.20	15.55	15.96	15.08	10.70	5.74

## ANGLE

20	-34.89	-34.39	-32.39	-37.67	-34.96	-31.29	-33.99	-40.38	-42.24
30	-31.96	-32.46	-31.69	-31.51	-33.10	-33.75	-33.20	-35.71	-41.80
40	-30.65	-32.46	-32.48	-33.93	-34.08	-30.74	-33.52	-33.16	-43.07
50	-27.72	-32.33	-30.36	-28.69	-29.20	-28.46	-30.18	-34.59	-42.04
60	-26.81	-24.96	-25.67	-25.64	-31.73	-28.69	-31.02	-34.34	-36.71
70	-28.54	-25.15	-22.97	-34.71	-27.25	-22.16	-22.14	-27.83	-35.94
80	-20.22	-19.95	-18.98	-17.37	-19.99	-26.49	-23.24	-28.48	-27.90

DLT-	23.16	22.05	19.22	16.10	15.40	15.65	14.84	10.28	5.30
------	-------	-------	-------	-------	-------	-------	-------	-------	------

63

VH	LENS-	-27.42	-30.68	-28.43	-31.61	-29.97	-30.12	-26.82	-34.33	-41.29
	DLL-	20.81	19.42	16.81	13.27	12.30	12.33	11.52	6.69	1.29
	DLT-	23.16	22.05	19.22	16.10	15.40	15.65	14.84	10.28	5.30

ANGLE

20	-50.23	-50.41	-48.69	-45.17	-48.72	-47.65	-47.70	-47.00	-54.48
30	-48.66	-46.54	-44.35	-44.01	-44.09	-43.60	-47.53	-46.02	-52.09
40	-44.85	-46.48	-46.01	-43.48	-42.94	-43.80	-45.89	-45.61	-52.63
50	-45.24	-45.04	-41.27	-44.34	-44.54	-44.77	-44.78	-44.70	-52.06
60	-46.15	-43.69	-42.12	-40.41	-42.57	-42.36	-48.67	-44.85	-51.07
70	-43.61	-43.89	-40.92	-44.67	-46.07	-40.27	-45.81	-43.55	-48.67
80	-41.39	-42.94	-33.08	-37.59	-36.07	-37.85	-45.71	-44.20	-48.03
DLT-	23.19	22.10	18.93	16.00	15.25	15.33	14.59	9.85	4.86

64

## SEA ICE DATA

## SPRING 1977 EXPERIMENT

DATE- MAY 21, 1977

SITE- 4 LOOK- 1

HH	LENS-	1.81	1.97	0.48	-0.29	-0.64	0.37	-0.34	-5.80	-12.05
	DLL-	20.81	19.42	16.81	13.27	12.30	12.33	11.52	6.69	1.29
	DLT-	23.03	21.94	19.38	15.99	15.57	15.83	15.08	10.97	6.74

## ANGLE

20	-34.61	-31.86	-34.32	-38.55	-39.36	-37.19	-39.73	-41.77	-42.55
30	-30.26	-30.15	-31.85	-28.54	-31.00	-30.94	-34.09	-36.62	-40.38
40	-25.18	-25.28	-24.91	-32.10	-32.74	-29.25	-29.01	-34.07	-35.44
50	-24.11	-25.60	-23.70	-29.32	-25.25	-26.49	-26.35	-33.56	-36.48
60	-26.92	-25.73	-25.87	-25.78	-21.89	-26.65	-24.17	-26.45	-36.18
70	-21.23	-19.13	-20.27	-24.06	-19.33	-21.95	-24.06	-26.13	-31.76
80	-20.64	-17.59	-16.31	-14.96	-14.90	-22.43	-19.97	-25.19	-27.76

DLT-	22.96	21.88	19.22	16.00	15.38	15.68	14.82	10.57	6.05
------	-------	-------	-------	-------	-------	-------	-------	-------	------

HV	LENS-	-25.73	-28.25	-27.74	-28.75	-28.64	-27.63	-27.66	-33.16	-35.71
	DLL-	20.81	19.42	16.81	13.27	12.30	12.33	11.52	6.69	1.29
	DLT-	22.96	21.88	19.22	16.00	15.38	15.68	14.82	10.57	6.05

## ANGLE

20	-46.56	-44.46	-44.39	-47.02	-48.93	-50.58	-46.71	-49.25	-48.24
30	-38.99	-40.44	-41.33	-40.37	-40.89	-40.00	-38.79	-44.97	-46.30
40	-39.37	-40.88	-36.53	-39.61	-37.96	-35.46	-40.45	-41.66	-44.60
50	-37.99	-35.05	-37.53	-37.51	-37.42	-33.64	-36.76	-43.25	-45.78
60	-35.76	-37.07	-34.52	-36.26	-34.36	-38.49	-41.00	-41.52	-46.10
70	-33.22	-33.16	-33.15	-35.02	-35.06	-37.07	-37.56	-36.90	-42.32
80	-31.60	-32.10	-32.25	-30.22	-29.11	-29.08	-30.47	-36.86	-41.53

DLT-	22.88	21.83	19.06	16.01	15.19	15.52	14.56	10.17	5.35
------	-------	-------	-------	-------	-------	-------	-------	-------	------

VV	LENS-	-0.35	-0.14	-0.91	-2.94	-2.88	-3.03	-4.97	-10.79	-16.30
	DLL-	20.81	19.42	16.81	13.27	12.30	12.33	11.52	6.69	1.29
	DLT-	22.88	21.83	19.06	16.01	15.19	15.52	14.56	10.17	5.35

## ANGLE

20	-35.48	-33.24	-34.67	-37.16	-40.67	-39.33	-36.89	-46.18	-46.65
30	-33.04	-32.77	-32.28	-31.21	-31.57	-32.20	-35.18	-40.56	-44.25
40	-26.86	-27.04	-27.28	-28.71	-30.91	-29.91	-31.95	-33.92	-38.26
50	-27.25	-27.78	-25.17	-29.78	-27.03	-30.60	-30.33	-32.76	-36.98
60	-28.75	-27.33	-24.99	-24.70	-22.16	-25.06	-23.44	-30.55	-35.31
70	-22.85	-20.91	-19.81	-24.43	-22.40	-24.38	-24.98	-26.25	-33.98
80	-19.78	-18.86	-18.35	-18.40	-12.97	-13.27	-22.30	-24.61	-28.52

DLT-	22.88	21.83	19.06	16.01	15.19	15.52	14.56	10.17	5.35
------	-------	-------	-------	-------	-------	-------	-------	-------	------

65

VH	LENS-	-27.42	-30.68	-28.43	-31.61	-29.97	-30.12	-26.82	-34.33	-41.29
	DLL-	20.81	19.42	16.81	13.27	12.30	12.33	11.52	6.69	1.29
	DLT-	22.88	21.83	19.06	16.01	15.19	15.52	14.56	10.17	5.35

ANGLE

20	-44.51	-44.83	-45.39	-44.94	-49.65	-50.70	-47.55	-45.90	-53.17
30	-38.06	-39.73	-40.50	-40.04	-40.71	-40.27	-38.81	-42.57	-47.78
40	-38.23	-38.92	-38.33	-38.17	-38.31	-37.48	-42.69	-41.21	-47.41
50	-35.04	-34.57	-37.14	-40.11	-39.55	-32.50	-37.51	-42.26	-45.33
60	-36.24	-34.96	-34.70	-36.14	-33.14	-38.16	-40.48	-41.82	-45.58
70	-32.91	-31.02	-32.26	-36.44	-35.13	-34.95	-34.70	-38.80	-43.86
80	-33.53	-32.63	-31.75	-30.72	-27.45	-28.76	-30.96	-34.22	-37.92
DLT-	22.88	21.83	19.06	16.01	15.19	15.52	14.56	10.17	5.35

## SEA ICE DATA SPRING 1977 EXPERIMENT

DATE- MAY 22, 1977 SITE- 4 LOOK- 2

HH	LENS-	1.81	1.97	0.48	-0.29	-0.64	0.37	-0.34	-5.80	-12.05
	DLL-	20.81	19.42	16.81	13.27	12.30	12.33	11.52	6.69	1.29
	DLT-	23.57	22.78	19.83	16.66	16.17	16.66	15.87	12.17	7.19

## ANGLE

20	-30.40	-28.84	-29.26	-30.62	-31.16	-30.95	-29.05	-34.30	-38.07
30	-23.62	-28.54	-26.80	-28.18	-26.74	-25.07	-22.97	-31.80	-33.04
40	-27.55	-24.50	-26.35	-23.54	-24.63	-22.96	-25.77	-31.48	-34.07
50	-26.70	-25.61	-23.62	-24.11	-27.60	-23.53	-24.22	-29.79	-35.38
60	-21.88	-20.06	-23.14	-24.52	-24.20	-23.58	-26.49	-31.18	-35.44
70	-22.56	-21.40	-21.35	-21.64	-20.93	-22.31	-21.08	-27.95	-29.49
80	-13.19	-15.41	-12.06	-15.11	-16.76	-17.07	-15.28	-20.46	-27.58
DLT-	23.42	22.69	19.44	16.59	16.05	16.19	15.62	11.88	6.44

HV	LENS-	-25.73	-28.25	-27.74	-28.75	-28.64	-27.63	-27.66	-33.16	-35.71
	DLL-	20.81	19.42	16.81	13.27	12.30	12.33	11.52	6.69	1.29
	DLT-	23.42	22.69	19.44	16.59	16.05	16.19	15.62	11.88	6.44

## ANGLE

20	-42.50	-44.55	-42.36	-44.18	-45.37	-41.43	-45.97	-48.05	-49.70
30	-38.33	-36.47	-35.30	-37.76	-35.27	-34.47	-34.10	-38.77	-46.01
40	-36.97	-34.39	-37.06	-35.00	-36.31	-33.93	-34.54	-36.96	-41.44
50	-33.42	-34.74	-35.01	-34.71	-33.94	-33.80	-33.21	-38.42	-43.71
60	-35.00	-34.11	-34.33	-33.82	-35.61	-30.90	-41.01	-42.68	-44.77
70	-33.06	-29.48	-31.45	-35.93	-30.54	-29.92	-30.92	-38.11	-38.97
80	-37.29	-30.65	-29.28	-31.24	-33.64	-29.43	-25.45	-32.76	-36.11
DLT-	23.28	22.61	19.06	16.51	15.93	15.71	15.37	11.60	5.68

VV	LENS-	-0.35	-0.14	-0.91	-2.94	-2.88	-3.03	-4.97	-10.79	-16.30
	DLL-	20.81	19.42	16.81	13.27	12.30	12.33	11.52	6.69	1.29
	DLT-	23.29	22.42	19.32	16.32	15.66	15.79	15.12	11.66	5.82

## ANGLE

20	-34.22	-33.79	-35.65	-34.27	-34.85	-36.70	-38.35	-40.00	-45.24
30	-28.35	-30.24	-30.47	-30.62	-26.53	-27.71	-28.84	-33.58	-35.98
40	-27.54	-26.41	-27.13	-26.20	-25.55	-26.93	-27.57	-35.90	-39.83
50	-23.76	-25.83	-25.61	-25.38	-26.56	-22.24	-23.88	-31.94	-36.49
60	-20.55	-21.28	-24.99	-24.44	-25.34	-24.40	-28.59	-30.97	-34.12
70	-21.09	-23.08	-23.00	-22.78	-22.56	-22.61	-21.71	-28.62	-29.82
80	-14.81	-16.66	-12.44	-16.21	-21.91	-17.66	-19.00	-20.66	-26.36
DLT-	23.13	22.18	19.04	16.07	15.37	15.49	14.80	10.68	5.31

VH	LENS-	-27.42	-30.68	-28.43	-31.61	-29.97	-30.12	-26.82	-34.33	-41.29
	DLL-	20.81	19.42	16.81	13.27	12.30	12.33	11.52	6.69	1.29
	DLT-	23.13	22.18	19.04	16.07	15.37	15.49	14.80	10.68	5.31

ANGLE

20	-41.97	-41.99	-41.23	-42.58	-44.56	-42.43	-44.46	-48.19	-52.81
30	-35.04	-38.65	-35.66	-38.60	-36.88	-36.86	-36.85	-38.80	-46.95
40	-37.25	-34.39	-34.70	-34.42	-36.35	-34.43	-35.59	-37.38	-45.42
50	-32.53	-32.62	-33.91	-35.30	-33.14	-33.19	-34.75	-38.00	-44.79
60	-34.08	-34.22	-35.30	-34.55	-35.18	-34.31	-37.67	-40.96	-43.50
70	-34.00	-30.66	-31.48	-34.49	-31.85	-31.51	-31.38	-36.52	-39.99
80	-32.88	-32.28	-28.65	-31.75	-28.91	-29.82	-29.20	-32.79	-41.73
DLT-	22.97	21.94	18.76	15.82	15.07	15.18	14.48	9.69	4.80

68

## SEA ICE DATA SPRING 1977 EXPERIMENT

DATE- MAY 22, 1977 SITE- 5 LOOK- 1

HH	LENS-	3.21	4.31	3.91	2.66	3.30	3.57	1.26	-4.97	-11.25
	DLL-	22.24	21.23	18.70	15.62	14.43	14.52	13.76	9.06	4.12
	DLT-	22.52	21.25	18.92	15.54	15.08	15.31	14.65	10.30	5.91

## ANGLE

20	-26.15	-26.63	-25.87	-28.83	-26.77	-27.64	-30.82	-33.58	-37.27
30	-23.69	-22.89	-20.33	-26.68	-18.64	-26.21	-22.96	-30.50	-33.86
40	-24.01	-20.60	-21.92	-21.83	-18.37	-19.13	-19.04	-23.93	-32.16
50	-19.39	-21.34	-18.26	-18.83	-19.03	-20.39	-24.72	-23.67	-24.91
60	-17.94	-16.97	-18.38	-20.56	-17.50	-17.50	-16.81	-22.11	-27.83
70	-16.84	-15.20	-16.60	-15.81	-13.36	-14.49	-22.81	-23.24	-25.65
80	-12.94	-15.27	-16.94	-20.24	-20.08	-19.82	-22.07	-19.02	-22.46

DLT-	22.53	21.37	18.81	15.49	14.87	15.13	14.38	9.94	5.35
------	-------	-------	-------	-------	-------	-------	-------	------	------

HV	LENS-	-27.13	-25.91	-25.22	-31.12	-24.70	-23.34	-26.06	-32.33	-34.91
	DLL-	22.24	21.23	18.70	15.62	14.43	14.52	13.76	9.06	4.12
	DLT-	22.53	21.37	18.81	15.49	14.87	15.13	14.38	9.94	5.35

## ANGLE

20	-37.57	-35.96	-37.29	-35.16	-39.87	-35.04	-38.37	-44.96	-48.01
30	-30.89	-32.23	-36.59	-32.69	-35.61	-32.07	-33.12	-38.77	-42.35
40	-30.83	-30.94	-30.36	-32.55	-31.69	-31.15	-30.99	-35.20	-42.39
50	-30.64	-29.50	-28.17	-28.24	-32.95	-27.72	-28.36	-32.68	-41.20
60	-28.29	-28.54	-30.43	-28.32	-29.51	-26.91	-27.82	-35.83	-36.30
70	-29.03	-29.20	-28.09	-29.73	-29.85	-23.65	-30.28	-34.47	-34.84
80	-30.34	-25.71	-28.57	-28.81	-28.72	-29.57	-24.75	-30.57	-38.33

DLT-	22.54	21.48	18.69	15.43	14.66	14.96	14.12	9.57	4.78
------	-------	-------	-------	-------	-------	-------	-------	------	------

VV	LENS-	-0.35	2.20	2.52	0.01	1.06	0.17	-3.37	-0.02	-15.16
	DLL-	22.24	21.23	18.70	15.62	14.43	14.52	13.76	9.06	4.12
	DLT-	22.24	21.23	18.70	15.62	14.43	14.52	13.76	9.06	4.12

## ANGLE

20	-25.30	-28.57	-24.56	-27.73	-27.76	-27.73	-33.22	-35.17	-42.46
30	-26.42	-23.93	-22.36	-25.81	-19.45	-27.56	-27.01	-33.69	-40.88
40	-21.85	-24.35	-22.29	-22.71	-18.33	-23.12	-18.96	-28.49	-32.11
50	-20.32	-24.02	-19.65	-20.40	-20.60	-22.12	-27.92	-30.91	-28.31
60	-19.78	-16.41	-20.00	-20.12	-17.05	-17.72	-17.33	-22.96	-28.68
70	-20.24	-16.58	-16.44	-18.63	-13.83	-13.90	-21.46	-24.02	-26.56
80	-14.73	-18.85	-15.07	-18.60	-20.19	-15.30	-21.26	-25.78	-26.01

DLT-	22.24	21.23	18.70	15.62	14.43	14.52	13.76	9.06	4.12
------	-------	-------	-------	-------	-------	-------	-------	------	------

69

VH LENS- -28.82 -28.34 -25.00 -28.66 -26.03 -26.56 -25.22 -23.56 -40.15  
DLL- 22.24 21.23 18.70 15.62 14.43 14.52 13.76 9.06 4.12

DLT- 22.24 21.23 18.70 15.62 14.43 14.52 13.76 9.06 4.12

ANGLE

20 -37.20 -34.81 -38.74 -35.57 -38.86 -34.81 -38.24 -45.37 -52.56  
30 -32.02 -33.47 -34.58 -34.90 -34.62 -32.72 -34.61 -40.55 -43.00  
40 -33.07 -32.88 -32.32 -33.41 -33.01 -32.01 -33.32 -35.70 -44.96  
50 -30.95 -30.95 -28.51 -30.20 -34.55 -28.82 -29.57 -33.69 -43.02  
60 -29.63 -29.61 -31.09 -30.86 -30.51 -29.02 -27.17 -34.14 -40.54  
70 -27.95 -29.66 -29.25 -29.04 -31.54 -28.18 -30.44 -34.30 -41.30  
80 -28.08 -26.55 -30.54 -31.06 -28.84 -29.69 -31.11 -32.76 -37.69

DLT- 22.24 21.23 18.70 15.62 14.43 14.52 13.76 9.06 4.12

## SEA ICE DATA

SPRING 1977 EXPERIMENT

DATE- MAY 23, 1977

SITE- 5 LOOK- 2

HH	LENS-	3.21	4.31	3.91	2.66	3.30	3.57	1.26	-4.97	-11.25
	DLL-	22.24	21.23	18.70	15.62	14.43	14.52	13.76	9.06	4.12
	DLT-	23.58	22.12	19.84	16.63	16.30	16.65	15.69	11.74	7.27

## ANGLE

20	-22.89	-23.90	-22.94	-24.48	-24.36	-22.33	-24.35	-30.70	-33.18
30	-20.18	-21.48	-18.48	-22.32	-21.53	-19.65	-22.03	-22.44	-28.48
40	-19.69	-17.92	-18.84	-18.77	-16.24	-22.23	-22.72	-23.38	-30.55
50	-17.91	-14.27	-17.33	-20.51	-18.70	-14.39	-17.22	-25.71	-28.26
60	-16.82	-13.14	-15.55	-18.54	-15.71	-17.27	-16.33	-23.76	-25.56
70	-13.55	-13.06	-15.47	-15.67	-16.94	-18.08	-20.70	-18.90	-30.59
80	-11.12	-12.52	-17.72	-16.31	-16.64	-14.52	-18.14	-20.36	-26.28
DLT-	23.43	22.52	19.72	16.79	16.13	16.34	15.47	11.48	6.60

HV	LENS-	-27.13	-25.91	-25.22	-31.12	-24.70	-23.34	-26.06	-32.33	-34.91
	DLL-	22.24	21.23	18.70	15.62	14.43	14.52	13.76	9.06	4.12
	DLT-	23.43	22.52	19.72	16.79	16.13	16.34	15.47	11.48	6.60

## ANGLE

20	-31.78	-33.49	-29.77	-29.26	-30.30	-30.29	-29.97	-35.86	-38.13
30	-30.30	-25.32	-28.20	-27.06	-26.17	-25.54	-25.28	-28.40	-34.64
40	-27.48	-26.19	-25.73	-26.91	-25.76	-24.78	-24.61	-26.82	-33.25
50	-26.36	-26.39	-27.63	-26.33	-22.93	-21.99	-22.82	-30.10	-33.75
60	-24.57	-24.65	-24.66	-25.05	-25.02	-22.54	-24.58	-25.92	-33.48
70	-26.68	-23.53	-23.26	-23.95	-23.46	-22.88	-23.07	-28.13	-32.98
80	-24.87	-24.22	-24.77	-25.08	-25.19	-23.07	-23.93	-27.67	-32.88
DLT-	23.28	22.91	19.61	16.95	15.95	16.02	15.24	11.21	5.93

VV	LENS-	-0.35	2.20	2.52	0.01	1.06	0.17	-3.37	-0.02	-15.16
	DLL-	22.24	21.23	18.70	15.62	14.43	14.52	13.76	9.06	4.12
	DLT-	23.12	21.86	19.41	16.20	15.64	15.98	15.06	10.44	5.98

## ANGLE

20	-21.77	-21.46	-22.02	-22.38	-22.94	-24.00	-26.00	-31.24	-34.95
30	-18.70	-17.26	-15.53	-17.64	-20.64	-19.86	-22.04	-24.41	-31.23
40	-17.36	-14.00	-17.70	-18.53	-16.83	-18.68	-20.04	-25.08	-30.26
50	-17.44	-16.95	-16.76	-19.40	-18.95	-15.71	-17.69	-21.27	-28.29
60	-12.80	-15.39	-14.62	-20.53	-17.44	-17.85	-16.53	-23.58	-27.76
70	-10.67	-12.84	-13.90	-16.12	-18.03	-16.82	-18.59	-21.24	-28.35
80	-9.85	-11.95	-15.22	-15.37	-15.72	-13.16	-16.12	-21.36	-28.31
DLT-	22.95	21.66	19.29	16.00	15.39	15.66	14.73	10.04	5.43

VH	LENS-	-28.82	-28.34	-25.00	-28.66	-26.03	-26.56	-25.22	-23.56	-40.15
	DLL-	22.24	21.23	18.70	15.62	14.43	14.52	13.76	9.06	4.12
	DLT-	22.95	21.66	19.29	16.00	15.39	15.66	14.73	10.04	5.43

ANGLE

20	-30.83	-33.35	-28.82	-29.63	-30.69	-28.60	-31.35	-36.20	-45.42
30	-29.77	-28.58	-28.21	-30.09	-28.42	-26.76	-27.63	-31.22	-37.94
40	-25.87	-25.67	-27.01	-27.42	-27.29	-23.31	-25.79	-28.25	-35.27
50	-25.37	-25.23	-25.42	-26.31	-24.10	-24.30	-25.59	-31.38	-35.56
60	-24.79	-26.42	-22.58	-25.56	-25.31	-23.73	-23.64	-27.71	-35.67
70	-24.56	-24.25	-24.40	-25.21	-25.60	-23.43	-25.22	-30.14	-32.96
80	-22.50	-24.50	-24.79	-27.96	-28.08	-22.91	-22.91	-30.70	-34.56
DLT-	22.78	21.47	19.16	15.80	15.14	15.34	14.40	9.63	4.88

## SEA ICE DATA SPRING 1977 EXPERIMENT

DATE- MAY 23, 1977 SITE- 5 LOOK- 3

HH	LENS-	3.21	4.31	3.91	2.66	3.30	3.57	1.26	-4.97	-11.25
	DLL-	22.24	21.23	18.70	15.62	14.43	14.52	13.76	9.06	4.12
	DLT-	22.26	21.16	18.74	15.41	14.97	15.04	14.16	9.63	5.53

## ANGLE

20	-23.79	-21.19	-21.55	-25.94	-25.03	-22.83	-22.55	-30.13	-32.85
30	-23.71	-22.98	-19.85	-23.94	-20.63	-20.71	-25.35	-26.24	-31.17
40	-21.28	-20.14	-18.32	-22.39	-20.64	-21.52	-23.98	-24.95	-32.00
50	-22.90	-19.94	-20.54	-19.39	-20.00	-18.97	-19.67	-26.68	-31.28
60	-19.94	-17.90	-19.89	-17.40	-20.63	-18.00	-22.04	-22.95	-30.05
70	-16.49	-17.17	-22.23	-22.01	-14.85	-24.48	-22.98	-25.50	-30.87
80	-13.91	-17.13	-17.56	-18.72	-17.35	-18.42	-17.92	-27.26	-28.51
DLT-	22.27	20.91	18.71	15.51	14.76	14.88	13.98	9.26	5.10

HV	LENS-	-27.13	-25.91	-25.22	-31.12	-24.70	-23.34	-26.06	-32.33	-34.91
	DLL-	22.24	21.23	18.70	15.62	14.43	14.52	13.76	9.06	4.12
	DLT-	22.27	20.91	18.71	15.51	14.76	14.88	13.98	9.26	5.10

## ANGLE

20	-29.72	-24.73	-26.41	-30.81	-31.41	-29.16	-29.70	-35.20	-41.00
30	-32.21	-28.48	-29.89	-28.97	-29.44	-28.14	-28.84	-32.28	-42.98
40	-31.55	-31.28	-27.75	-29.67	-30.02	-27.97	-31.66	-33.67	-40.74
50	-30.06	-28.17	-29.38	-28.84	-28.27	-27.16	-33.87	-34.48	-37.45
60	-30.16	-24.12	-26.24	-27.07	-27.67	-27.65	-25.68	-34.72	-37.12
70	-29.00	-24.16	-25.84	-28.57	-27.67	-25.92	-27.99	-31.78	-37.16
80	-29.09	-28.58	-27.43	-28.08	-29.23	-28.23	-29.86	-32.61	-34.92
DLT-	22.28	20.66	18.67	15.61	14.55	14.71	13.79	8.90	4.67

VV	LENS-	-0.35	2.20	2.52	0.01	1.06	0.17	-3.37	-0.02	-15.16
	DLL-	22.24	21.23	18.70	15.62	14.43	14.52	13.76	9.06	4.12
	DLT-	22.06	20.95	18.77	15.35	14.58	14.63	13.76	9.02	4.65

## ANGLE

20	-20.30	-19.17	-21.29	-26.30	-23.26	-23.13	-24.31	-27.56	-34.88
30	-21.28	-21.66	-19.17	-25.55	-20.41	-21.80	-25.97	-27.50	-31.63
40	-17.98	-20.03	-20.92	-21.86	-17.16	-19.38	-21.56	-26.18	-37.83
50	-19.27	-18.06	-19.01	-19.21	-15.85	-20.29	-21.42	-26.64	-28.67
60	-18.99	-16.45	-17.57	-17.87	-18.76	-15.72	-22.90	-22.54	-31.74
70	-14.11	-16.79	-18.57	-18.08	-14.63	-22.15	-23.66	-27.75	-27.94
80	-15.90	-16.14	-18.68	-14.18	-16.15	-18.20	-19.65	-22.30	-27.49
DLT-	22.06	20.95	18.77	15.35	14.58	14.63	13.76	9.02	4.65

VH	LENS-	-28.82	-28.34	-25.00	-28.66	-26.03	-26.56	-25.22	-23.56	-40.15
	DLL-	22.24	21.23	18.70	15.62	14.43	14.52	13.76	9.06	4.12
	DLT-	22.06	20.95	18.77	15.35	14.58	14.63	13.76	9.02	4.65

ANGLE

20	-28.64	-28.56	-27.04	-30.22	-30.04	-28.84	-30.59	-35.50	-42.19
30	-27.37	-27.61	-28.47	-31.03	-31.58	-28.18	-32.84	-34.23	-43.18
40	-29.84	-29.51	-25.58	-29.87	-31.29	-29.34	-33.83	-35.49	-43.47
50	-28.18	-28.29	-29.31	-29.24	-27.98	-29.31	-34.52	-34.25	-39.86
60	-27.93	-27.08	-28.22	-28.23	-30.70	-29.14	-27.65	-34.58	-41.84
70	-28.98	-25.25	-25.59	-29.93	-28.74	-25.46	-28.26	-32.25	-37.46
80	-28.31	-27.60	-27.98	-30.80	-30.83	-27.95	-27.46	-32.37	-37.81
DLT-	22.06	20.95	18.77	15.35	14.58	14.63	13.76	9.02	4.65

## SEA ICE DATA SPRING 1977 EXPERIMENT

DATE- MAY 23, 1977 SITE- 5 LOOK- 4

HH	LENS-	3.21	4.31	3.91	2.66	3.30	3.57	1.26	-4.97	-11.25
	DLL-	22.24	21.23	18.70	15.62	14.43	14.52	13.76	9.06	4.12
	DLT-	21.64	20.50	18.12	14.81	14.12	14.24	13.30	8.93	4.42

## ANGLE

20	-25.88	-26.14	-26.34	-31.09	-24.06	-25.31	-26.77	-31.03	-35.15
30	-23.69	-21.64	-21.13	-23.83	-23.13	-22.66	-24.59	-30.21	-34.47
40	-21.72	-21.77	-21.40	-22.87	-22.30	-23.20	-19.99	-29.73	-33.91
50	-21.66	-20.02	-20.02	-22.04	-20.86	-17.55	-22.29	-28.25	-34.17
60	-18.73	-19.84	-19.83	-21.55	-18.82	-14.83	-14.20	-24.06	-34.50
70	-17.11	-17.40	-18.01	-17.76	-17.20	-15.30	-20.57	-23.81	-22.98
80	-20.14	-19.40	-15.23	-15.07	-14.78	-18.49	-23.28	-28.54	-26.87

DLT-	21.64	20.50	18.12	14.81	14.12	14.24	13.30	8.93	4.42
------	-------	-------	-------	-------	-------	-------	-------	------	------

HV	LENS-	-27.13	-25.91	-25.22	-31.12	-24.70	-23.34	-26.06	-32.33	-34.91
	DLL-	22.24	21.23	18.70	15.62	14.43	14.52	13.76	9.06	4.12

DLT-	21.64	20.50	18.12	14.81	14.12	14.24	13.30	8.93	4.42
------	-------	-------	-------	-------	-------	-------	-------	------	------

## ANGLE

20	-33.50	-33.60	-34.18	-36.32	-34.01	-35.78	-36.52	-37.15	-45.63
30	-32.02	-31.32	-31.36	-31.69	-32.82	-31.55	-33.75	-40.51	-44.66
40	-32.21	-31.89	-30.47	-29.28	-30.44	-30.78	-34.08	-35.92	-44.37
50	-32.56	-28.90	-32.97	-34.30	-32.37	-30.00	-34.07	-36.89	-42.46
60	-29.21	-30.15	-30.69	-29.85	-28.68	-30.42	-30.58	-35.06	-44.88
70	-30.87	-30.91	-30.35	-31.56	-28.12	-29.40	-32.47	-37.43	-40.56
80	-32.02	-32.39	-28.10	-26.00	-28.64	-31.13	-33.02	-33.68	-38.56

DLT-	21.64	20.50	18.12	14.81	14.12	14.24	13.30	8.93	4.42
------	-------	-------	-------	-------	-------	-------	-------	------	------

VV	LENS-	-0.35	2.20	2.52	0.01	1.06	0.17	-3.37	-0.02	-15.16
	DLL-	22.24	21.23	18.70	15.62	14.43	14.52	13.76	9.06	4.12

DLT-	21.64	20.50	18.12	14.81	14.12	14.24	13.30	8.93	4.42
------	-------	-------	-------	-------	-------	-------	-------	------	------

## ANGLE

20	-25.25	-24.96	-25.33	-28.46	-25.95	-23.42	-26.62	-32.14	-35.37
30	-25.42	-21.07	-21.52	-23.26	-22.83	-20.93	-23.36	-31.34	-35.09
40	-22.64	-21.22	-20.78	-21.70	-22.26	-24.67	-22.19	-30.99	-37.07
50	-18.79	-18.76	-18.78	-25.59	-23.04	-21.08	-21.52	-26.47	-33.89
60	-19.85	-17.23	-22.33	-20.18	-16.76	-16.69	-15.38	-25.09	-35.70
70	-19.76	-19.64	-17.54	-20.96	-14.40	-15.53	-21.65	-21.49	-31.67
80	-17.43	-14.97	-17.20	-14.92	-13.21	-17.00	-23.96	-25.84	-30.39

DLT-	21.64	20.50	18.12	14.81	14.12	14.24	13.30	8.93	4.42
------	-------	-------	-------	-------	-------	-------	-------	------	------

VH	LENS-	-28.82	-28.34	-25.00	-28.66	-26.03	-26.56	-25.22	-23.56	-40.15
	DLL-	22.24	21.23	18.70	15.62	14.43	14.52	13.76	9.06	4.12
	DLT-	21.64	20.50	18.12	14.81	14.12	14.24	13.30	8.93	4.42

ANGLE

20	-34.90	-34.13	-34.44	-35.70	-35.37	-35.96	-35.86	-37.74	-47.14
30	-34.31	-31.54	-32.69	-32.22	-32.89	-31.99	-34.95	-40.90	-43.50
40	-31.70	-31.82	-29.83	-30.72	-31.71	-32.58	-34.19	-37.03	-42.73
50	-32.38	-28.12	-31.23	-33.36	-31.82	-29.38	-32.94	-36.13	-43.24
60	-29.48	-30.22	-30.36	-30.87	-30.36	-28.91	-34.35	-37.50	-41.34
70	-31.45	-31.74	-33.60	-32.98	-31.56	-28.37	-29.84	-42.20	-40.97
80	-29.53	-31.14	-28.47	-29.30	-31.05	-30.81	-31.84	-35.74	-44.82
DLT-	21.64	20.50	18.12	14.81	14.12	14.24	13.30	8.93	4.42

SEA ICE DATA      SPRING 1977 EXPERIMENT

DATE- MAY 23, 1977      SITE- 5    LOOK- 5

HH    LENS-    3.21    4.31    3.91    2.66    3.30    3.57    1.26    -4.97    -11.25  
       DLL-    22.24    21.23    18.70    15.62    14.43    14.52    13.76    9.06    4.12  
       DLT-    22.33    21.11    18.61    15.09    14.61    14.89    13.99    9.51    5.50

ANGLE

20    -33.00    -28.37    -29.73    -28.36    -26.52    -29.52    -31.23    -32.60    -35.96  
 30    -26.56    -27.11    -25.55    -26.35    -26.94    -23.27    -26.05    -27.94    -38.41  
 40    -26.46    -25.83    -28.91    -27.07    -24.72    -22.73    -24.72    -31.80    -35.65  
 50    -23.27    -21.09    -19.51    -26.10    -22.61    -22.95    -25.26    -30.47    -31.86  
 60    -26.22    -16.71    -21.16    -21.21    -24.41    -25.71    -21.76    -27.77    -30.50  
 70    -23.08    -17.92    -23.26    -21.75    -22.24    -18.91    -19.84    -23.38    -30.63  
 80    -21.97    -17.98    -19.47    -16.55    -22.07    -19.03    -19.12    -24.07    -26.10

DLT-    22.33    21.11    18.61    15.09    14.61    14.89    13.99    9.51    5.50

HV    LENS-    -27.13    -25.91    -25.22    -31.12    -24.70    -23.34    -26.06    -32.33    -34.91  
       DLL-    22.24    21.23    18.70    15.62    14.43    14.52    13.76    9.06    4.12  
       DLT-    22.33    21.11    18.61    15.09    14.61    14.89    13.99    9.51    5.50

ANGLE

20    -43.74    -39.47    -39.24    -40.74    -38.00    -37.46    -39.46    -42.07    -48.03  
 30    -38.27    -37.29    -37.69    -39.04    -34.85    -35.66    -39.75    -38.89    -44.07  
 40    -37.10    -38.41    -34.28    -32.54    -33.73    -33.24    -34.52    -38.80    -43.20  
 50    -33.75    -33.86    -33.90    -35.23    -31.33    -30.65    -34.53    -37.74    -43.93  
 60    -37.65    -34.13    -34.91    -35.88    -32.81    -31.00    -31.51    -35.60    -44.16  
 70    -36.18    -28.30    -31.75    -32.54    -33.23    -34.75    -35.33    -36.72    -41.55  
 80    -36.34    -33.99    -32.70    -36.27    -31.52    -28.62    -31.98    -42.48    -42.56

DLT-    22.16    20.95    18.46    15.02    14.44    14.71    13.78    9.23    5.14

VV    LENS-    -0.35    2.20    2.52    0.01    1.06    0.17    -3.37    -0.02    -15.16  
       DLL-    22.24    21.23    18.70    15.62    14.43    14.52    13.76    9.06    4.12  
       DLT-    22.16    20.95    18.46    15.02    14.44    14.71    13.78    9.23    5.14

ANGLE

20    -28.48    -27.43    -27.89    -25.82    -27.94    -30.03    -28.65    -32.01    -36.34  
 30    -24.52    -24.75    -26.19    -27.09    -27.42    -24.59    -23.52    -30.10    -36.62  
 40    -21.36    -23.46    -26.75    -24.37    -24.39    -23.05    -26.07    -34.58    -36.19  
 50    -18.18    -19.14    -18.00    -26.29    -20.47    -23.69    -24.67    -30.15    -31.92  
 60    -24.39    -16.51    -17.01    -20.12    -22.74    -20.21    -19.47    -31.10    -30.58  
 70    -18.90    -16.59    -21.95    -20.03    -20.37    -20.39    -22.38    -26.57    -33.54  
 80    -17.09    -17.10    -18.45    -16.36    -22.51    -20.14    -19.02    -22.15    -24.07

DLT-    22.33    21.11    18.61    15.09    14.61    14.89    13.99    9.51    5.50

77

VH	LENS-	-28.82	-28.34	-25.00	-28.66	-26.03	-26.56	-25.22	-23.56	-40.15
	DLL-	22.24	21.23	18.70	15.62	14.43	14.52	13.76	9.06	4.12
	DLT-	22.33	21.11	18.61	15.09	14.61	14.89	13.99	9.51	5.50

ANGLE

20	-41.30	-33.77	-38.74	-42.04	-38.64	-38.76	-38.92	-41.49	-48.56
30	-35.36	-36.96	-37.20	-37.72	-36.25	-36.69	-40.55	-40.75	-44.97
40	-31.92	-37.96	-35.20	-33.16	-34.60	-32.83	-35.16	-38.88	-43.52
50	-30.71	-32.53	-32.36	-34.11	-31.04	-30.68	-35.17	-36.31	-43.94
60	-36.55	-34.39	-35.54	-35.22	-32.51	-34.63	-35.23	-36.29	-43.49
70	-31.62	-29.32	-34.40	-32.15	-35.41	-33.61	-35.94	-39.06	-41.93
80	-34.13	-32.94	-32.67	-35.88	-30.79	-29.97	-33.12	-40.04	-44.59
DLT-	22.00	20.80	18.30	14.96	14.27	14.52	13.56	8.95	4.77

SEA ICE DATA      SPRING 1977 EXPERIMENT

DATE- MAY 23, 1977      SITE- 5    LOOK- 6

HH	LENS-	3.21	4.31	3.91	2.66	3.30	3.57	1.26	-4.97	-11.25
	DLL-	22.24	21.23	18.70	15.62	14.43	14.52	13.76	9.06	4.12
	DLT-	21.84	20.64	18.15	14.89	14.10	14.34	13.35	8.67	4.41

ANGLE

20	-31.90	-29.27	-28.66	-30.27	-27.81	-26.95	-29.89	-34.13	-38.71
30	-25.97	-26.43	-28.27	-25.27	-26.06	-25.47	-26.37	-32.61	-37.63
40	-25.21	-28.31	-25.35	-23.88	-23.17	-24.31	-24.60	-36.39	-34.59
50	-23.49	-23.64	-22.65	-23.86	-24.62	-21.70	-22.40	-26.34	-34.48
60	-21.51	-23.10	-23.11	-21.95	-20.58	-20.26	-26.97	-27.35	-32.16
70	-23.67	-23.03	-24.67	-22.98	-23.72	-20.82	-22.34	-24.48	-34.78
80	-19.34	-17.81	-17.27	-17.21	-19.80	-16.51	-23.09	-24.95	-32.65

DLT-	21.84	20.64	18.15	14.89	14.10	14.34	13.35	8.67	4.41
------	-------	-------	-------	-------	-------	-------	-------	------	------

HV	LENS-	-27.13	-25.91	-25.22	-31.12	-24.70	-23.34	-26.06	-32.33	-34.91
	DLL-	22.24	21.23	18.70	15.62	14.43	14.52	13.76	9.06	4.12
	DLT-	21.84	20.64	18.15	14.89	14.10	14.34	13.35	8.67	4.41

ANGLE

20	-44.48	-41.46	-36.50	-37.49	-39.91	-38.52	-39.88	-42.91	-45.72
30	-39.13	-36.82	-37.03	-37.16	-37.00	-38.71	-37.84	-42.21	-44.70
40	-37.36	-34.85	-33.93	-34.11	-36.78	-33.93	-38.02	-38.85	-46.44
50	-34.65	-32.71	-36.25	-35.96	-34.34	-35.95	-33.42	-36.05	-45.62
60	-35.71	-35.46	-32.41	-35.71	-33.47	-34.05	-37.87	-44.21	-40.54
70	-32.89	-35.88	-36.87	-36.80	-34.49	-34.88	-35.34	-37.14	-45.81
80	-36.90	-33.95	-32.57	-32.76	-34.28	-30.76	-37.14	-38.94	-41.46

DLT-	21.84	20.64	18.15	14.89	14.10	14.34	13.35	8.67	4.41
------	-------	-------	-------	-------	-------	-------	-------	------	------

VV	LENS-	-0.35	2.20	2.52	0.01	1.06	0.17	-3.37	-0.02	-15.16
	DLL-	22.24	21.23	18.70	15.62	14.43	14.52	13.76	9.06	4.12
	DLT-	21.84	20.64	18.15	14.89	14.10	14.34	13.35	8.67	4.41

ANGLE

20	-27.63	-28.27	-27.66	-30.40	-29.13	-25.40	-26.76	-38.07	-37.49
30	-23.29	-24.04	-24.42	-23.67	-25.17	-25.15	-26.86	-31.57	-36.07
40	-21.56	-23.66	-23.84	-20.92	-21.43	-24.56	-25.66	-29.77	-35.23
50	-18.52	-22.96	-19.15	-22.80	-23.23	-20.80	-22.44	-29.93	-34.63
60	-19.79	-20.80	-21.62	-19.41	-18.39	-20.68	-24.39	-27.45	-31.40
70	-19.92	-20.03	-21.37	-20.85	-20.87	-17.99	-23.06	-26.26	-34.07
80	-14.98	-15.80	-16.12	-15.35	-17.66	-14.75	-22.04	-25.48	-30.51

DLT-	21.84	20.64	18.15	14.89	14.10	14.34	13.35	8.67	4.41
------	-------	-------	-------	-------	-------	-------	-------	------	------

VH	LENS-	-28.82	-28.34	-25.00	-28.66	-26.03	-26.56	-25.22	-23.56	-40.15
	DLL-	22.24	21.23	18.70	15.62	14.43	14.52	13.76	9.06	4.12
	DLT-	21.84	20.64	18.15	14.89	14.10	14.34	13.35	8.67	4.41

ANGLE

20	C.	0.	0.	0.	0.	0.	0.	0.	0.	0.
30	C.	0.	0.	0.	0.	0.	0.	0.	0.	0.
40	C.	0.	0.	0.	0.	0.	0.	0.	0.	0.
50	C.	0.	0.	0.	0.	0.	0.	0.	0.	0.
60	C.	0.	0.	0.	0.	0.	0.	0.	0.	0.
70	C.	0.	0.	0.	0.	0.	0.	0.	0.	0.
80	C.	0.	0.	0.	0.	0.	0.	0.	0.	0.

DLT-	21.84	20.64	18.15	14.89	14.10	14.34	13.35	8.67	4.41
------	-------	-------	-------	-------	-------	-------	-------	------	------

## SEA ICE DATA SPRING 1977 EXPERIMENT

DATE- MAY 25, 1977 SITE- 6 LOOK- 1

HH	LENS-	5.69	6.09	6.53	5.75	6.52	6.70	3.44	-1.67	-6.42
	DLL-	22.05	21.08	18.43	15.77	14.60	14.81	13.83	8.78	4.48
	DLT-	22.05	21.08	18.43	15.77	14.60	14.81	13.83	8.78	4.48

## ANGLE

20	-39.24	-37.53	-39.54	-38.40	-38.36	-37.52	-39.61	-42.40	-47.27
30	-36.63	-34.77	-34.78	-35.06	-35.65	-36.75	-36.98	-41.14	-44.05
40	-33.56	-32.51	-33.68	-33.08	-33.14	-33.68	-31.94	-35.40	-43.26
50	-31.40	-30.33	-30.34	-33.80	-33.92	-29.79	-30.16	-35.14	-43.65
60	-31.14	-29.91	-25.93	-30.37	-25.85	-27.86	-25.48	-33.14	-37.70
70	-29.09	-27.16	-29.64	-28.93	-24.83	-27.50	-23.63	-30.62	-36.19
80	-26.33	-28.01	-28.11	-29.54	-27.64	-23.46	-26.34	-35.45	-36.43

DLT-	22.05	21.08	18.43	15.77	14.60	14.81	13.83	8.78	4.48
------	-------	-------	-------	-------	-------	-------	-------	------	------

HV	LENS-	-23.25	-24.13	-22.60	-22.71	-21.48	-20.21	-27.88	-29.03	-30.08
	DLL-	22.05	21.08	18.43	15.77	14.60	14.81	13.83	8.78	4.48
	DLT-	22.05	21.08	18.43	15.77	14.60	14.81	13.83	8.78	4.48

## ANGLE

20	-45.82	-45.63	-45.54	-43.73	-45.87	-44.83	-46.90	-50.30	-56.67
30	-42.77	-43.72	-44.26	-43.18	-43.53	-47.79	-44.16	-47.12	-53.16
40	-40.74	-42.32	-43.16	-42.98	-42.43	-41.59	-42.90	-46.88	-53.18
50	-42.88	-41.72	-39.31	-42.24	-43.87	-40.25	-42.90	-46.05	-50.09
60	-39.26	-41.25	-41.16	-41.95	-43.20	-41.61	-39.25	-44.89	-49.76
70	-40.94	-39.63	-40.21	-39.07	-42.53	-40.45	-41.61	-44.17	-46.61
80	-37.55	-39.36	-38.98	-40.77	-39.96	-38.03	-42.74	-44.81	-46.82

DLT-	22.05	21.08	18.43	15.77	14.60	14.81	13.83	8.78	4.48
------	-------	-------	-------	-------	-------	-------	-------	------	------

VV	LENS-	3.53	3.98	5.14	3.10	4.28	3.30	-1.19	-6.66	-10.33
	DLL-	22.05	21.08	18.43	15.77	14.60	14.81	13.83	8.78	4.48
	DLT-	22.05	21.08	18.43	15.77	14.60	14.81	13.83	8.78	4.48

## ANGLE

20	-35.02	-33.96	-35.33	-34.86	-35.67	-33.73	-38.18	-41.69	-46.82
30	-36.84	-31.64	-33.37	-32.62	-32.86	-33.53	-34.66	-41.93	-46.11
40	-33.23	-32.23	-31.67	-33.40	-30.82	-30.80	-29.99	-35.69	-41.31
50	-28.06	-27.37	-27.53	-31.46	-32.82	-29.24	-31.03	-35.74	-43.11
60	-29.69	-29.59	-28.24	-28.38	-28.31	-29.51	-24.74	-36.97	-39.83
70	-29.42	-28.71	-31.26	-27.15	-23.95	-26.47	-23.03	-31.59	-36.77
80	-23.81	-28.35	-30.75	-30.71	-26.82	-24.11	-26.96	-33.76	-35.87

DLT-	22.05	21.08	18.43	15.77	14.60	14.81	13.83	8.78	4.48
------	-------	-------	-------	-------	-------	-------	-------	------	------

VH LENS- -24.94 -26.56 -22.37 -22.57 -22.51 -21.42 -23.04 -30.20 -35.32  
DLL- 22.05 21.08 18.43 15.77 14.60 14.81 13.83 8.78 4.48

DLT- 22.05 21.08 18.43 15.77 14.60 14.81 13.83 8.78 4.48

ANGLE

20 -46.45 -47.99 -45.73 -41.39 -46.28 -46.50 -47.78 -49.11 -57.28  
30 -43.50 -42.60 -44.86 -41.26 -43.83 -46.98 -46.88 -48.63 -52.57  
40 -40.23 -41.45 -43.75 -41.17 -43.92 -42.24 -43.24 -47.43 -53.58  
50 -41.96 -41.03 -40.70 -40.24 -43.01 -42.46 -43.90 -46.02 -50.28  
60 -39.24 -40.72 -40.15 -40.87 -44.45 -42.33 -41.76 -47.67 -50.98  
70 -42.33 -39.05 -41.57 -39.89 -45.34 -40.48 -41.57 -45.94 -48.77  
80 -38.69 -38.17 -40.77 -39.61 -45.32 -42.82 -43.57 -46.66 -48.22

DLT- 22.05 21.08 18.43 15.77 14.60 14.81 13.83 8.78 4.48

SEA ICE DATA      SPRING 1977 EXPERIMENT

DATE- MAY 25, 1977      SITE- 6    LOOK- 2

HH    LENS-    5.69    6.09    6.53    5.75    6.52    6.70    3.44    -1.67    -6.42  
       DLL-    22.05    21.08    18.43    15.77    14.60    14.81    13.83    8.78    4.48  
       DLT-    21.46    19.95    17.65    14.47    13.70    13.72    12.70    8.03    3.76

ANGLE

20    -36.86    -39.23    -39.31    -38.87    -39.14    -37.16    -39.90    -42.15    -47.82  
 30    -35.16    -35.17    -35.80    -36.66    -35.63    -34.71    -34.81    -40.56    -44.65  
 40    -33.05    -34.26    -33.16    -33.41    -34.50    -32.14    -36.67    -40.28    -44.37  
 50    -31.04    -32.04    -33.27    -35.08    -33.80    -33.33    -33.41    -37.36    -42.65  
 60    -32.30    -32.79    -33.77    -32.65    -32.60    -33.48    -33.76    -40.44    -40.44  
 70    -33.35    -34.06    -32.79    -32.23    -34.81    -31.85    -36.85    -35.15    -44.10  
 80    -31.08    -25.08    -30.62    -32.60    -32.88    -30.50    -34.98    -37.29    -39.88

DLT-    21.46    19.95    17.65    14.47    13.70    13.72    12.70    8.03    3.76

HV    LENS-    -23.25    -24.13    -22.60    -22.71    -21.48    -20.21    -27.88    -29.03    -30.08  
       DLL-    22.05    21.08    18.43    15.77    14.60    14.81    13.83    8.78    4.48  
       DLT-    21.46    19.95    17.65    14.47    13.70    13.72    12.70    8.03    3.76

ANGLE

20    -45.35    -45.91    -46.34    -45.75    -51.07    -51.99    -48.96    -50.75    -56.72  
 30    -43.01    -46.71    -44.09    -44.81    -46.00    -47.37    -47.03    -48.34    -54.77  
 40    -42.91    -42.81    -45.66    -44.65    -44.34    -44.83    -46.19    -47.26    -52.83  
 50    -42.54    -42.46    -44.46    -43.09    -42.85    -43.03    -43.46    -45.41    -51.28  
 60    -43.35    -43.57    -40.94    -41.95    -42.54    -42.97    -43.03    -44.60    -52.23  
 70    -41.91    -37.55    -40.18    -42.05    -44.19    -43.87    -45.62    -44.29    -50.69  
 80    -41.03    -42.91    -43.74    -43.65    -42.89    -41.92    -44.35    -45.78    -47.00

DLT-    21.46    19.95    17.65    14.47    13.70    13.72    12.70    8.03    3.76

VV    LENS-    3.53    3.98    5.14    3.10    4.28    3.30    -1.19    -6.66    -10.33  
       DLL-    22.05    21.08    18.43    15.77    14.60    14.81    13.83    8.78    4.48  
       DLT-    21.46    19.95    17.65    14.47    13.70    13.72    12.70    8.03    3.76

ANGLE

20    -37.30    -40.38    -39.35    -39.59    -42.16    -40.29    -41.94    -45.42    -50.93  
 30    -35.99    -36.08    -37.10    -37.41    -35.48    -35.39    -36.89    -43.52    -48.16  
 40    -33.54    -34.20    -33.85    -34.67    -36.19    -37.35    -40.08    -42.32    -47.02  
 50    -33.87    -32.80    -35.46    -35.84    -38.51    -32.25    -42.40    -40.31    -44.78  
 60    -32.55    -30.31    -35.80    -33.90    -33.40    -37.88    -34.24    -40.65    -42.51  
 70    -32.69    -34.27    -32.01    -31.32    -32.78    -30.89    -37.38    -37.51    -45.51  
 80    -32.33    -26.49    -30.97    -36.16    -32.39    -31.49    -35.41    -38.36    -40.93

DLT-    21.46    19.95    17.65    14.47    13.70    13.72    12.70    8.03    3.76

VH	LENS-	-24.94	-26.56	-22.37	-22.57	-22.81	-21.42	-23.04	-30.20	-35.32
	DLL-	22.05	21.08	18.43	15.77	14.60	14.81	13.83	8.78	4.48
	DLT-	21.46	19.95	17.65	14.47	13.70	13.72	12.70	8.03	3.76

ANGLE

20	-45.28	-45.98	-46.67	-45.33	-48.96	-50.81	-48.41	-52.57	-50.15
30	-43.04	-45.00	-44.36	-44.01	-45.47	-50.39	-45.26	-50.59	-49.85
40	-42.25	-42.06	-44.22	-44.18	-45.58	-45.38	-45.26	-48.39	-49.37
50	-41.40	-41.05	-43.73	-42.60	-42.76	-43.35	-43.15	-47.15	-48.77
60	-41.93	-43.79	-41.69	-42.10	-42.34	-42.75	-45.10	-47.36	-49.94
70	-42.04	-38.54	-39.51	-42.31	-44.38	-43.77	-44.74	-46.94	-48.00
80	-42.15	-39.98	-44.39	-42.97	-42.37	-42.35	-46.84	-47.98	-47.77
DLT-	21.46	19.95	17.65	14.47	13.70	13.72	12.70	8.03	3.76

## SEA ICE DATA

SPRING 1977 EXPERIMENT

DATE- MAY 26, 1977

SITE- 6 LOOK- 3

HH	LENS-	5.69	6.09	6.53	5.75	6.52	6.70	3.44	-1.67	-6.42
	DLL-	22.05	21.08	18.43	15.77	14.60	14.81	13.83	8.78	4.48
	DLT-	22.60	21.22	18.73	15.60	15.19	15.66	14.37	9.80	6.04

## ANGLE

20	-35.75	-34.57	-35.69	-39.46	-36.90	-36.95	-37.19	-41.99	-43.36
30	-33.03	-33.41	-34.10	-35.59	-34.29	-33.13	-36.89	-37.97	-41.36
40	-33.60	-32.01	-33.45	-34.34	-32.04	-33.39	-32.29	-37.22	-42.87
50	-30.93	-31.27	-31.35	-31.55	-32.70	-29.95	-33.25	-36.11	-41.81
60	-31.74	-30.74	-31.66	-32.38	-30.83	-27.26	-31.46	-35.98	-41.33
70	-26.71	-26.84	-26.39	-31.89	-31.00	-30.18	-32.49	-35.18	-37.32
80	-28.37	-25.89	-27.98	-28.70	-25.40	-24.48	-24.26	-33.83	-36.10

DLT-	22.26	20.69	18.34	15.15	14.64	15.07	13.73	8.97	4.99
------	-------	-------	-------	-------	-------	-------	-------	------	------

58

HV	LENS-	-23.25	-24.13	-22.60	-22.71	-21.48	-20.21	-27.88	-29.03	-30.08
	DLL-	22.05	21.08	18.43	15.77	14.60	14.81	13.83	8.78	4.48
	DLT-	22.26	20.69	18.34	15.15	14.64	15.07	13.73	8.97	4.99

## ANGLE

20	-42.82	-43.38	-42.22	-43.32	-45.28	-45.02	-45.50	-46.33	-55.75
30	-41.67	-42.63	-41.18	-42.03	-44.31	-42.19	-45.96	-44.16	-50.24
40	-40.29	-39.63	-41.80	-43.24	-40.90	-40.21	-42.61	-44.77	-49.73
50	-40.49	-40.88	-40.89	-38.52	-41.07	-40.34	-41.49	-44.28	-47.88
60	-40.30	-34.68	-38.56	-40.51	-40.69	-40.70	-41.46	-43.09	-48.11
70	-41.36	-37.52	-40.13	-40.39	-41.98	-36.22	-40.81	-43.07	-46.58
80	-40.46	-38.76	-35.11	-40.58	-41.60	-39.22	-39.38	-43.13	-47.97

DLT-	21.92	20.16	17.94	14.69	14.09	14.48	13.09	8.14	3.93
------	-------	-------	-------	-------	-------	-------	-------	------	------

VV	LENS-	3.53	3.98	5.14	3.10	4.28	3.30	-1.19	-6.66	-10.33
	DLL-	22.05	21.08	18.43	15.77	14.60	14.81	13.83	8.78	4.48
	DLT-	21.92	20.16	17.94	14.69	14.09	14.48	13.09	8.14	3.93

## ANGLE

20	-35.12	-34.21	-34.10	-36.37	-36.47	-33.12	-36.27	-42.42	-47.65
30	-31.70	-32.46	-34.69	-37.09	-33.79	-33.01	-36.17	-38.48	-43.88
40	-33.31	-30.66	-31.69	-33.74	-34.49	-33.43	-32.32	-37.09	-43.41
50	-30.49	-30.81	-32.44	-31.10	-32.24	-31.60	-34.09	-38.77	-41.30
60	-29.68	-30.13	-29.98	-32.28	-32.21	-31.39	-30.94	-37.17	-41.61
70	-28.73	-29.76	-25.89	-30.89	-30.03	-28.77	-32.87	-36.49	-38.80
80	-29.93	-27.39	-29.55	-29.59	-29.62	-27.81	-27.09	-33.66	-37.07

DLT-	21.78	20.00	17.76	14.49	13.98	14.38	12.99	8.25	4.25
------	-------	-------	-------	-------	-------	-------	-------	------	------

VH	LENS-	-24.94	-26.56	-22.37	-22.57	-22.81	-21.42	-23.04	-30.20	-35.32
	DLL-	22.05	21.08	18.43	15.77	14.60	14.81	13.83	8.78	4.48
	DLT-	21.78	20.00	17.76	14.49	13.98	14.38	12.99	8.25	4.25

ANGLE

20	-42.94	-43.15	-42.68	-41.71	-46.82	-45.07	-46.72	-50.02	-55.54
30	-42.44	-43.67	-42.48	-41.99	-44.36	-43.46	-44.67	-47.34	-51.17
40	-40.44	-39.96	-41.09	-40.68	-41.44	-41.10	-42.83	-45.61	-48.97
50	-41.57	-42.48	-42.50	-39.11	-43.98	-40.57	-41.12	-43.19	-48.88
60	-39.71	-35.96	-39.72	-39.57	-40.85	-41.16	-40.69	-45.78	-49.62
70	-39.26	-37.24	-40.87	-39.88	-43.14	-39.90	-42.38	-43.81	-47.15
80	-38.23	-38.22	-37.88	-40.37	-41.97	-38.96	-39.47	-44.64	-47.61
DLT-	21.63	19.83	17.57	14.29	13.87	14.27	12.88	8.37	4.57

AD-A052 711

KANSAS UNIV/CENTER FOR RESEARCH INC LAWRENCE REMOTE --ETC F/G 17/9  
BACKSCATTER PROPERTIES OF SEA ICE WITH RADAR. ARCTIC OPERATIONS--ETC(U)  
OCT 77 R G ONSTOTT, G J DOME, R A HAND N00014-76-C-1105

UNCLASSIFIED

RSL-TM-331-1

NL

2 OF 2  
AD  
A052 711

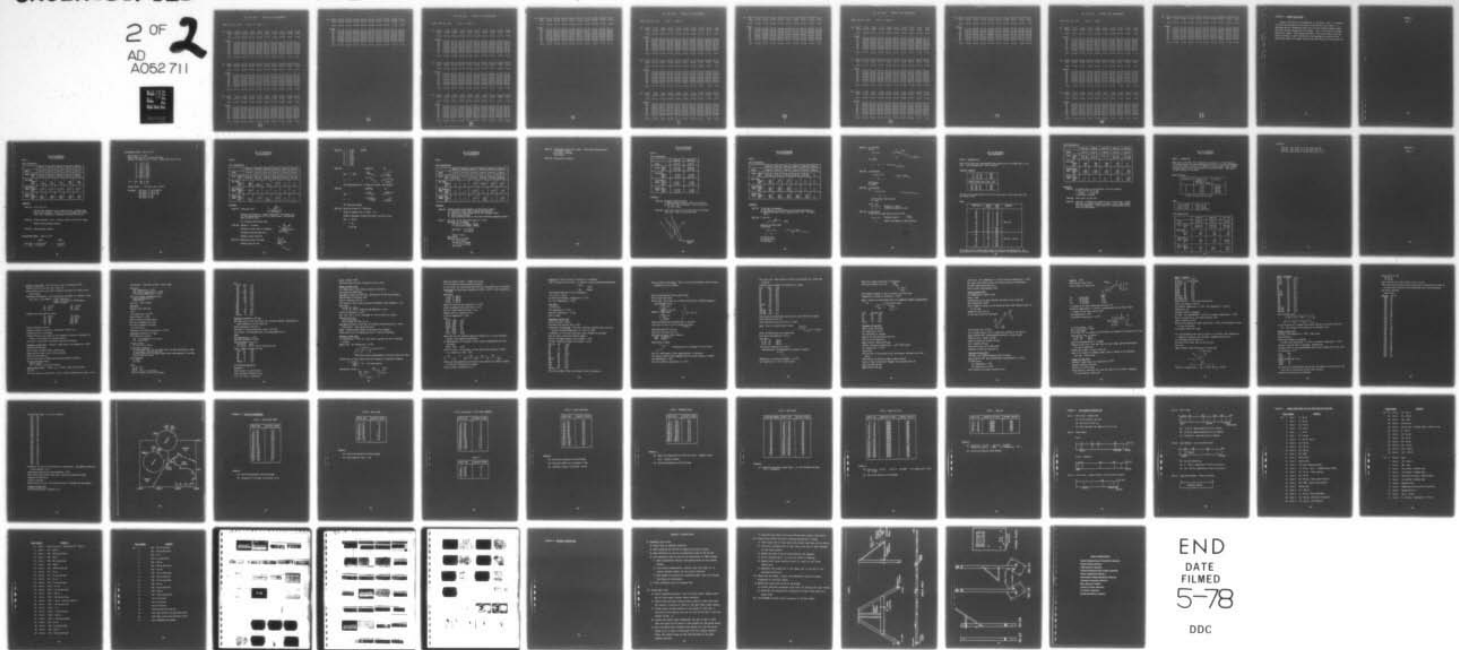

END  
DATE  
FILMED  
5-78  
DDC

## SEA ICE DATA

## SPRING 1977 EXPERIMENT

DATE- MAY 26, 1977

SITE- 6 LOOK- 4

HH	LENS-	5.69	6.09	6.53	5.75	6.52	6.70	3.44	-1.67	-6.42
	DLL-	22.05	21.08	18.43	15.77	14.60	14.81	13.83	8.78	4.48
	DLT-	21.62	19.84	17.55	14.29	13.77	14.25	12.85	8.24	4.38

## ANGLE

20	-37.96	-38.61	-40.35	-41.35	-39.27	-40.81	-42.20	-43.89	-48.12
30	-39.53	-37.03	-40.11	-35.62	-36.71	-36.27	-38.15	-41.43	-46.50
40	-34.95	-33.45	-33.68	-37.00	-34.60	-36.91	-37.85	-41.41	-47.98
50	-34.33	-35.17	-35.13	-34.52	-34.71	-36.32	-39.42	-39.31	-47.00
60	-32.66	-34.24	-34.20	-34.65	-34.86	-37.62	-36.88	-40.54	-44.69
70	-33.23	-34.15	-30.77	-36.13	-30.82	-33.62	-33.19	-38.72	-43.09
80	-27.20	-21.94	-25.83	-30.03	-23.64	-23.44	-25.55	-35.24	-40.70
DLT-	21.57	19.60	17.31	14.06	13.48	13.89	12.47	7.57	3.61

HV	LENS-	-23.25	-24.13	-22.60	-22.71	-21.48	-20.21	-27.88	-29.03	-30.08
	DLL-	22.05	21.08	18.43	15.77	14.60	14.81	13.83	8.78	4.48
	DLT-	21.57	19.60	17.31	14.06	13.48	13.89	12.47	7.57	3.61

## ANGLE

20	-43.54	-43.46	-46.70	-43.56	-47.97	-47.57	-51.68	-54.74	-54.03
30	-42.09	-43.10	-42.95	-41.55	-45.63	-46.86	-45.77	-50.97	-55.97
40	-43.17	-42.87	-42.59	-43.16	-42.58	-42.58	-45.62	-50.60	-55.26
50	-39.64	-42.68	-43.47	-41.44	-43.25	-44.76	-44.92	-50.46	-53.29
60	-39.47	-39.69	-41.79	-38.21	-44.76	-41.48	-42.84	-47.54	-52.07
70	-36.85	-39.58	-40.85	-41.65	-41.90	-43.76	-42.18	-46.97	-49.80
80	-40.90	-41.18	-41.35	-42.62	-41.79	-41.46	-44.00	-44.83	-54.12
DLT-	21.51	19.36	17.07	13.83	13.18	13.53	12.09	6.90	2.83

VV	LENS-	3.53	3.98	5.14	3.10	4.28	3.30	-1.19	-6.66	-10.33
	DLL-	22.05	21.08	18.43	15.77	14.60	14.81	13.83	8.78	4.48
	DLT-	21.51	19.36	17.07	13.83	13.18	13.53	12.09	6.90	2.83

## ANGLE

20	-39.80	-39.78	-42.06	-41.92	-42.51	-43.80	-46.60	-50.78	-50.24
30	-37.24	-37.20	-38.22	-37.71	-37.71	-40.50	-44.01	-44.21	-50.54
40	-36.88	-34.48	-36.35	-38.23	-37.61	-36.06	-41.74	-43.74	-49.56
50	-35.37	-35.56	-34.49	-35.78	-38.43	-36.10	-36.92	-43.01	-48.44
60	-35.27	-32.11	-34.58	-36.57	-33.98	-37.91	-38.45	-41.05	-46.04
70	-33.17	-32.17	-32.00	-33.53	-32.28	-34.88	-34.74	-41.88	-45.29
80	-26.23	-21.80	-26.57	-28.39	-23.29	-21.17	-26.87	-37.36	-37.72
DLT-	21.28	19.12	16.89	13.59	12.86	13.13	11.72	6.33	2.06

VH	LENS-	-24.94	-26.56	-22.37	-22.57	-22.81	-21.42	-23.04	-30.20	-35.32
	DLL-	22.05	21.08	18.43	15.77	14.60	14.81	13.83	8.78	4.48
	DLT-	21.28	19.12	16.89	13.59	12.86	13.13	11.72	6.33	2.06

ANGLE

20	-45.15	-44.32	-46.04	-40.59	-48.70	-48.60	-53.30	-53.11	-56.40
30	-43.13	-43.64	-43.46	-40.10	-46.00	-47.24	-45.13	-51.33	-55.81
40	-41.70	-42.20	-43.70	-40.20	-46.15	-43.15	-45.99	-51.53	-55.05
50	-42.90	-42.95	-42.73	-40.30	-45.50	-46.18	-46.57	-50.80	-53.56
60	-41.53	-41.76	-41.21	-40.54	-45.15	-45.29	-45.52	-47.53	-53.11
70	-37.34	-41.16	-38.65	-40.13	-44.40	-40.48	-46.76	-50.42	-53.78
80	-41.08	-41.00	-41.89	-39.99	-44.03	-39.94	-44.08	-47.72	-52.87
DLT-	21.04	18.88	16.72	13.34	12.53	12.74	11.34	5.77	1.29

## SEA ICE DATA

SPRING 1977 EXPERIMENT

DATE- MAY 26, 1977

SITE- 6 LOOK- 5

HH	LENS-	5.69	6.09	6.53	5.75	6.52	6.70	3.44	-1.67	-6.42
	DLL-	22.05	21.08	18.43	15.77	14.60	14.81	13.83	8.78	4.48
	DLT-	20.79	19.02	16.67	13.51	12.83	12.92	11.40	6.94	2.98

## ANGLE

20	-46.59	-47.17	-43.78	-43.69	-43.27	-43.20	-46.58	-47.57	-55.46
30	-45.81	-40.77	-42.18	-41.41	-39.58	-36.95	-41.09	-45.22	-48.45
40	-36.81	-41.39	-35.64	-37.16	-35.66	-34.02	-38.08	-44.51	-45.24
50	-40.29	-36.60	-33.85	-29.95	-31.03	-31.20	-36.33	-43.30	-45.37
60	-34.73	-33.77	-37.38	-36.14	-34.71	-30.16	-35.56	-35.06	-47.54
70	-37.00	-35.43	-32.42	-34.12	-28.68	-36.29	-41.96	-38.55	-49.55
80	-29.23	-29.62	-26.56	-30.94	-28.60	-35.54	-35.28	-32.50	-41.55

DLT-	20.64	18.88	16.56	13.38	12.64	12.79	11.27	6.39	2.22
------	-------	-------	-------	-------	-------	-------	-------	------	------

HV	LENS-	-23.25	-24.13	-22.60	-22.71	-21.48	-20.21	-27.88	-29.03	-30.08
	DLL-	22.05	21.08	18.43	15.77	14.60	14.81	13.83	8.78	4.48
	DLT-	20.64	18.88	16.56	13.38	12.64	12.79	11.27	6.39	2.22

## ANGLE

20	-59.63	-59.83	-58.57	-43.03	-61.00	-64.20	-58.21	-53.73	-57.76
30	-54.50	-52.88	-52.82	-42.69	-56.64	-57.47	-57.52	-53.50	-57.00
40	-54.11	-53.98	-53.96	-42.16	-47.08	-52.31	-55.66	-53.48	-56.96
50	-46.51	-46.67	-51.22	-44.52	-46.39	-51.93	-53.05	-54.02	-56.60
60	-47.01	-45.43	-48.37	-42.66	-46.57	-47.06	-54.46	-54.25	-55.43
70	-48.29	-46.42	-44.24	-43.11	-46.30	-46.23	-50.34	-56.73	-55.06
80	-43.39	-46.69	-44.35	-41.09	-48.58	-43.38	-47.13	-52.23	-53.56

DLT-	20.49	18.75	16.44	13.24	12.44	12.67	11.14	5.84	1.45
------	-------	-------	-------	-------	-------	-------	-------	------	------

VV	LENS-	3.53	3.98	5.14	3.10	4.28	3.30	-1.19	-6.66	-10.33
	DLL-	22.05	21.08	18.43	15.77	14.60	14.81	13.83	8.78	4.48
	DLT-	20.49	18.75	16.44	13.24	12.44	12.67	11.14	5.84	1.45

## ANGLE

20	-56.80	-55.67	-49.59	-42.37	-58.72	-57.63	-56.28	-52.90	-56.84
30	-48.03	-45.31	-40.90	-41.64	-50.74	-50.98	-54.06	-53.96	-56.24
40	-42.47	-47.62	-44.11	-41.64	-42.35	-41.42	-46.98	-51.99	-56.71
50	-43.94	-45.83	-45.10	-39.28	-42.74	-44.87	-51.50	-51.62	-53.15
60	-36.94	-40.29	-42.31	-39.03	-47.71	-41.33	-47.24	-51.29	-55.58
70	-38.09	-38.09	-40.65	-39.31	-38.57	-42.36	-43.81	-50.77	-55.79
80	-32.45	-34.75	-33.18	-38.21	-36.85	-38.91	-44.25	-42.88	-53.16

DLT-	20.35	18.61	16.31	13.03	12.17	12.34	10.56	5.50	0.80
------	-------	-------	-------	-------	-------	-------	-------	------	------

89

VH	LENS-	-24.94	-26.56	-22.37	-22.57	-22.81	-21.42	-23.04	-30.20	-35.32
	DLL-	22.05	21.08	18.43	15.77	14.60	14.81	13.83	8.78	4.48
	DLT-	20.35	18.61	16.31	13.03	12.17	12.34	10.56	5.50	0.80

ANGLE

20	-63.45	-63.44	-62.23	-39.58	-64.38	-65.26	-55.84	-56.79	-60.41
30	-57.61	-62.12	-46.83	-39.67	-60.39	-63.63	-56.47	-56.49	-60.22
40	-56.93	-57.55	-58.25	-40.06	-58.11	-59.55	-58.07	-54.63	-58.81
50	-50.32	-53.59	-56.22	-40.31	-56.55	-57.86	-57.59	-53.36	-58.00
60	-50.33	-53.19	-49.10	-40.13	-57.08	-57.84	-57.52	-53.55	-58.19
70	-45.50	-43.51	-47.32	-39.97	-54.38	-51.69	-54.06	-53.12	-57.92
80	-47.68	-46.47	-45.75	-40.16	-48.91	-51.23	-53.84	-52.10	-56.39
DLT-	20.21	18.47	16.18	12.82	11.90	12.01	9.97	5.16	0.14

## SEA ICE DATA

## SPRING 1977 EXPERIMENT

DATE- MAY 28, 1977

SITE- 7 LOOK- 1

HH	LENS-	4.15	4.68	5.74	4.92	5.65	5.49	2.78	3.33	7.29
	DLL-	21.54	19.81	17.72	14.72	14.13	14.26	13.17	8.14	3.82
	DLT-	21.54	19.81	17.72	14.72	14.13	14.26	13.17	8.14	3.82

## ANGLE

20	-30.29	-28.12	-28.82	-27.64	-27.64	-28.07	-30.80	-34.06	-40.69
30	-27.71	-31.00	-30.43	-30.56	-27.34	-28.57	-29.79	-32.85	-37.29
40	-29.47	-27.00	-28.83	-29.62	-29.45	-26.57	-24.87	-33.68	-37.95
50	-26.67	-27.13	-28.60	-25.40	-27.53	-24.57	-30.23	-32.90	-34.67
60	-22.03	-29.84	-25.71	-28.05	-24.00	-24.44	-24.95	-31.61	-37.45
70	-25.38	-22.64	-20.16	-23.90	-26.74	-25.83	-25.88	-28.39	-33.47
80	-16.46	-17.54	-17.74	-16.72	-17.32	-18.45	-19.84	-24.54	-32.52
DLT-	21.36	19.59	17.49	14.64	13.89	13.98	12.88	7.67	3.47

HV	LENS-	-24.79	-25.54	-23.39	-23.54	-22.35	-23.43	-24.54	-30.69	-30.95
	DLL-	21.54	19.81	17.72	14.72	14.13	14.26	13.17	8.14	3.82
	DLT-	21.36	19.59	17.49	14.64	13.89	13.98	12.88	7.67	3.47

## ANGLE

20	-45.34	-43.78	-44.47	-41.17	-42.61	-41.83	-42.55	-46.72	-51.29
30	-42.90	-44.89	-44.41	-41.83	-41.23	-40.19	-42.44	-44.78	-48.37
40	-43.60	-43.81	-43.22	-41.49	-41.05	-41.98	-41.39	-45.84	-48.93
50	-41.46	-42.22	-45.25	-43.66	-42.00	-40.48	-43.28	-46.98	-48.60
60	-43.27	-41.77	-44.46	-42.58	-40.01	-39.86	-42.85	-45.77	-52.15
70	-41.66	-43.25	-42.18	-38.74	-39.83	-38.90	-39.94	-43.72	-46.75
80	-39.88	-38.01	-41.71	-41.42	-39.84	-39.58	-39.09	-43.18	-49.70
DLT-	21.17	19.37	17.26	14.56	13.65	13.70	12.59	7.20	3.13

VV	LENS-	1.99	2.57	4.35	2.27	3.41	2.09	-1.85	-8.32	-11.20
	DLL-	21.54	19.81	17.72	14.72	14.13	14.26	13.17	8.14	3.82
	DLT-	21.17	19.37	17.26	14.56	13.65	13.70	12.59	7.20	3.13

## ANGLE

20	-36.22	-35.61	-37.06	-34.79	-35.33	-32.54	-36.83	-41.46	-45.23
30	-34.20	-35.45	-35.63	-33.75	-34.15	-32.17	-35.34	-40.32	-45.77
40	-32.56	-33.11	-32.49	-33.74	-31.71	-32.54	-33.40	-38.30	-41.97
50	-36.50	-34.32	-31.21	-33.15	-31.66	-33.80	-35.42	-36.75	-43.06
60	-26.60	-32.16	-31.27	-33.03	-30.40	-31.13	-29.88	-35.88	-41.59
70	-32.57	-24.66	-25.28	-30.62	-29.07	-30.05	-30.83	-33.28	-38.60
80	-26.52	-19.08	-18.54	-19.50	-19.89	-20.31	-25.39	-27.40	-37.49
DLT-	20.88	19.04	16.86	14.12	13.19	13.32	12.11	7.06	3.04

91

VH	LENS-	-26.48	-27.97	-23.17	-26.40	-23.68	-24.64	-23.70	-31.86	-36.19
	DLL-	21.54	19.81	17.72	14.72	14.13	14.26	13.17	8.14	3.82
	DLT-	20.88	19.04	16.86	14.12	13.19	13.32	12.11	7.06	3.04

ANGLE

20	-47.08	-45.30	-47.53	-40.88	-44.09	-42.75	-43.46	-50.30	-52.92
30	-46.61	-48.19	-45.39	-39.49	-42.36	-41.29	-44.18	-46.50	-51.86
40	-44.61	-47.04	-46.32	-40.78	-44.92	-43.16	-43.37	-48.60	-52.78
50	-44.41	-43.58	-46.94	-41.50	-44.14	-43.68	-45.87	-47.15	-51.86
60	-46.87	-43.68	-44.88	-42.18	-42.25	-41.31	-44.13	-49.70	-52.77
70	-43.40	-45.34	-41.47	-38.89	-38.21	-39.45	-41.74	-44.39	-53.30
80	-42.74	-38.97	-38.08	-37.55	-42.15	-46.00	-43.28	-45.04	-46.89
DLT-	20.58	18.71	16.45	13.67	12.72	12.93	11.63	6.91	2.95

## SEA ICE DATA

SPRING 1977 EXPERIMENT

DATE- MAY 28, 1977

SITE- 7 LOOK- 2

HH	LENS-	4.15	4.68	5.74	4.92	5.65	5.49	2.78	3.33	7.29
	DLL-	21.54	19.81	17.72	14.72	14.13	14.26	13.17	8.14	3.82
	DLT-	20.92	19.11	16.84	13.92	13.36	13.81	12.64	8.20	4.29

## ANGLE

20	-30.00	-29.28	-29.09	-32.18	-29.05	-29.13	-31.85	-33.88	-37.21
30	-29.05	-30.47	-23.14	-24.89	-28.73	-27.10	-29.64	-30.78	-34.92
40	-30.40	-27.59	-25.25	-27.36	-28.61	-26.73	-27.35	-30.32	-34.10
50	-27.35	-27.04	-27.17	-25.63	-24.08	-26.83	-27.61	-27.75	-35.60
60	-28.04	-25.52	-24.22	-25.90	-24.99	-24.21	-27.00	-30.25	-31.07
70	-27.87	-27.59	-27.36	-24.72	-23.89	-21.18	-22.94	-30.68	-33.58
80	-25.21	-22.00	-19.85	-21.73	-26.19	-12.81	-15.46	-24.62	-26.70
DLT-	20.71	18.84	16.54	13.56	12.91	13.35	12.13	7.44	3.30

HV	LENS-	-24.79	-25.54	-23.39	-23.54	-22.35	-23.43	-24.54	-30.69	-30.95
	DLL-	21.54	19.81	17.72	14.72	14.13	14.26	13.17	8.14	3.82
	DLT-	20.71	18.84	16.54	13.56	12.91	13.35	12.13	7.44	3.30

## ANGLE

20	-43.74	-44.84	-42.41	-41.55	-41.33	-39.93	-41.45	-46.53	-52.58
30	-43.00	-43.94	-42.02	-37.20	-39.44	-40.01	-41.01	-43.67	-50.07
40	-42.68	-42.06	-37.36	-40.85	-40.96	-38.93	-40.26	-44.70	-50.61
50	-43.68	-38.50	-41.14	-38.68	-41.95	-38.80	-41.99	-45.34	-50.22
60	-42.94	-44.69	-40.36	-41.15	-41.70	-41.29	-39.06	-44.27	-48.50
70	-42.60	-43.41	-40.02	-41.34	-45.32	-41.21	-42.59	-46.99	-47.69
80	-42.41	-41.05	-39.10	-44.34	-42.26	-34.54	-38.76	-45.20	-44.60
DLT-	20.49	18.56	16.24	13.20	12.46	12.88	11.63	6.67	2.30

VV	LENS-	1.99	2.57	4.35	2.27	3.41	2.09	-1.85	-8.32	-11.20
	DLL-	21.54	19.81	17.72	14.72	14.13	14.26	13.17	8.14	3.82
	DLT-	20.49	18.56	16.24	13.20	12.46	12.88	11.63	6.67	2.30

## ANGLE

20	-36.16	-35.68	-35.35	-33.99	-33.93	-34.87	-34.10	-39.92	-43.19
30	-32.56	-32.53	-32.35	-33.78	-30.95	-31.65	-35.44	-36.54	-43.84
40	-33.73	-32.32	-35.59	-30.72	-28.88	-29.98	-32.34	-35.24	-43.75
50	-31.10	-29.63	-30.34	-29.68	-32.96	-26.91	-31.00	-37.34	-42.98
60	-30.96	-29.52	-30.89	-25.51	-25.82	-25.97	-27.89	-34.79	-36.23
70	-30.43	-29.51	-29.81	-30.74	-27.89	-22.42	-31.98	-28.91	-37.76
80	-25.30	-32.24	-27.81	-24.91	-29.94	-22.07	-22.41	-24.01	-28.49
DLT-	20.24	18.30	16.00	11.93	12.12	12.50	10.88	5.99	1.27

VH	LENS-	-26.48	-27.97	-23.17	-26.40	-23.68	-24.64	-23.70	-31.86	-36.19
	DLL-	21.54	19.81	17.72	14.72	14.13	14.26	13.17	8.14	3.82
	DLT-	20.24	18.30	16.00	11.93	12.12	12.50	10.88	5.99	1.27

ANGLE

20	-43.37	-45.42	-43.58	-37.85	-43.97	-40.02	-42.76	-48.36	-53.13
30	-43.22	-45.36	-41.92	-38.03	-42.80	-39.60	-41.82	-47.00	-52.68
40	-43.11	-43.74	-39.10	-38.86	-41.12	-41.19	-42.38	-44.88	-50.40
50	-43.05	-39.72	-43.11	-38.02	-46.09	-40.94	-42.44	-46.74	-49.68
60	-45.25	-44.92	-42.44	-39.35	-44.31	-37.73	-41.35	-45.33	-49.20
70	-43.87	-44.97	-42.36	-38.65	-45.09	-43.84	-43.36	-45.12	-51.20
80	-42.77	-41.51	-37.03	-40.29	-41.99	-40.43	-39.75	-41.43	-46.26
DLT-	19.99	18.03	15.75	10.66	11.78	12.13	10.13	5.30	0.23

94

## SEA ICE DATA

SPRING 1977 EXPERIMENT

DATE- MAY 28, 1977

SITE- 7 LOOK- 3

HH	LENS-	4.15	4.68	5.74	4.92	5.65	5.49	2.78	3.33	7.29
	DLL-	21.54	19.81	17.72	14.72	14.13	14.26	13.17	8.14	3.82
	DLT-	19.97	18.14	15.71	12.68	11.99	12.38	10.59	6.25	2.16

## ANGLE

20	-31.18	-30.14	-29.92	-27.35	-26.65	-27.64	-28.89	-33.30	-38.85
30	-31.01	-27.20	-26.65	-27.72	-29.46	-27.03	-28.15	-31.34	-36.67
40	-28.10	-30.45	-29.72	-30.20	-26.95	-23.92	-30.69	-34.52	-37.64
50	-24.97	-29.86	-24.75	-29.74	-30.15	-25.93	-34.67	-30.62	-33.57
60	-29.75	-26.82	-28.03	-22.45	-25.82	-23.00	-26.22	-34.50	-34.45
70	-20.22	-21.89	-22.06	-27.11	-22.05	-21.21	-29.61	-29.32	-35.71
80	-20.83	-24.73	-18.84	-19.96	-16.56	-22.20	-21.53	-22.96	-28.40

DLT-	19.80	17.99	15.59	12.48	11.70	12.08	10.19	5.64	1.11
------	-------	-------	-------	-------	-------	-------	-------	------	------

HV	LENS-	-24.79	-25.54	-23.39	-23.54	-22.35	-23.43	-24.54	-30.69	-30.95
	DLL-	21.54	19.81	17.72	14.72	14.13	14.26	13.17	8.14	3.82

DLT-	19.80	17.99	15.59	12.48	11.70	12.08	10.19	5.64	1.11
------	-------	-------	-------	-------	-------	-------	-------	------	------

## ANGLE

20	-42.24	-44.27	-43.13	-38.49	-40.63	-39.61	-42.20	-47.19	-52.08
30	-41.65	-44.65	-41.55	-38.37	-42.66	-39.02	-41.34	-44.52	-49.33
40	-43.75	-42.21	-41.58	-41.35	-41.45	-40.01	-41.04	-44.74	-46.75
50	-44.32	-40.78	-38.25	-39.77	-41.68	-40.45	-41.81	-45.61	-51.00
60	-42.86	-39.91	-42.12	-39.47	-39.54	-39.46	-40.95	-43.97	-47.52
70	-42.90	-41.59	-40.79	-39.59	-41.42	-39.78	-37.94	-43.14	-47.32
80	-41.12	-39.32	-40.48	-40.57	-37.67	-34.00	-38.11	-41.32	-46.14

DLT-	19.62	17.83	15.46	12.27	11.41	11.78	9.79	5.03	0.06
------	-------	-------	-------	-------	-------	-------	------	------	------

VV	LENS-	1.99	2.57	4.35	2.27	3.41	2.09	-1.85	-8.32	-11.20
	DLL-	21.54	19.81	17.72	14.72	14.13	14.26	13.17	8.14	3.82

DLT-	19.62	17.83	15.46	12.27	11.41	11.78	9.79	5.03	0.06
------	-------	-------	-------	-------	-------	-------	------	------	------

## ANGLE

20	-31.92	-35.05	-34.10	-33.34	-31.90	-32.31	-33.24	-39.72	-43.64
30	-34.42	-33.92	-29.90	-31.41	-33.24	-32.24	-34.05	-39.97	-42.93
40	-31.80	-32.67	-32.51	-33.90	-28.59	-31.35	-31.52	-34.31	-38.42
50	-28.19	-32.12	-28.15	-30.70	-27.96	-28.07	-31.51	-34.42	-41.62
60	-32.79	-28.22	-32.16	-24.29	-29.54	-27.81	-29.14	-35.62	-36.50
70	-20.72	-24.28	-24.45	-32.59	-28.04	-23.85	-28.09	-31.81	-38.68
80	-19.57	-21.32	-21.42	-21.88	-24.60	-26.52	-24.82	-27.17	-33.89

DLT-	19.46	17.69	15.27	11.78	10.88	11.24	9.46	4.73	-0.40
------	-------	-------	-------	-------	-------	-------	------	------	-------

95

VH	LENS-	-26.48	-27.97	-23.17	-26.40	-23.68	-24.64	-23.70	-31.86	-36.19
	DLL-	21.54	19.81	17.72	14.72	14.13	14.26	13.17	8.14	3.82
	DLT-	19.46	17.69	15.27	11.78	10.88	11.24	9.46	4.73	-0.40

ANGLE

20	-42.41	-45.53	-43.44	-37.77	-42.52	-38.51	-41.43	-47.87	-52.52
30	-43.55	-43.62	-41.42	-36.54	-45.79	-41.55	-40.79	-46.27	-48.57
40	-45.64	-42.64	-43.25	-37.84	-43.04	-41.18	-40.64	-45.39	-48.61
50	-44.57	-41.56	-41.72	-38.18	-42.90	-42.18	-43.34	-48.32	-53.91
60	-42.47	-42.57	-42.98	-38.51	-44.22	-38.79	-43.11	-45.72	-49.80
70	-43.20	-43.82	-42.44	-38.14	-43.31	-40.14	-38.21	-45.07	-48.77
80	-40.48	-44.72	-42.03	-37.92	-36.01	-37.19	-37.33	-45.42	-48.39
DLT-	19.30	17.56	15.07	11.29	10.36	10.70	9.13	4.42	-0.85

APPENDIX D. GROUND TRUTH NOTES

Ground truth notes are included here in two parts. Part I is information that was available to the author at the start of this report. It tabulates general information about each site and contains comments about the sites and the functioning of the radar. Part II consists of the notes taken by Dr. Weeks. These became available in the later stage of writing and are included in their received form to supplement the notes of Part I. These notes contain Dr. Week's ground truth description of the snow and ice.

APPENDIX D

PART I

SEA ICE EXPERIMENT  
SITE DESCRIPTION

SITE 1:

LOOK INFORMATION:

	LOOK #1	LOOK #2	LOOK #3	LOOK #4	LOOK #5
DATE:	5-14-77	5-14-77	5-14-77	5-15-77	5-15-77
TIME: START END	9:45 am 11:00 am	12:30 pm 1:30 pm	2:30 pm 3:30 pm	9:00 am 10:30 am	1:45 pm 2:30 pm
AIR TEMP: START END	--- -6°C	--- -6°C	--- -6°C	-4°C -4°C	-4°C -4°C
ICE SURFACE TEMP: START END	-5.5°C ---	-5.5°C ---	-5.5°C ---	-5.5°C ---	-5.5°C ---
DELAY LINE TEMP: START END	13°C 18°C	18°C 18°C	18°C 18°C	2°C 2°C	2°C 2°C

COMMENTS:

LOOK #1:   / 12"

Noticed what appeared to be a jump in meter readings when used in auto ranging. Checked it out on example and looked like 6 dB. Am going to use manual settings from now on.

LOOK #4: L-Band cross-pol lens -9.64 dB, reads as 20--9.64 on tape.

Totally uninterrupted surface.

LOOK #5: Uninterrupted surface.

CALIBRATION CHECK: MAY 16, 1977

	Found		Reset
KuX freq	$\Rightarrow 4.25 \times 10^{-3}$	--	$4.3 \times 10^{-3}$
L freq	$\Rightarrow 4.80 \times 10^{-3}$	--	$4.8 \times 10^{-3}$

## CALIBRATION CHECK: MAY 16, 1977

DAC-02 bias  $\Rightarrow$  1 volt  
center freq bias  $\Rightarrow$  1 volt/1.9/2.8/etc.  
freq #9  $\Rightarrow$  center is 8.3 volts; should have been 9 volts.

1	8.5 - 9.5
2	9.5 - 10.5
3	10.5 - 11.5
4	11.5 - 12.5
5	12.5 - 13.5
6	13.5 - 14.5
7	14.5 - 15.5
8	15.5 - 16.5
9	16.5 - 17.5

fs = Kux OK  $\rightarrow$  OK  
L OK  $\rightarrow$  OK

L-Band center = 69.5 mA set to 72 mA

Volatage: 26 volts  $\Rightarrow$  26 volts OK  
+18 volts  $\Rightarrow$  18.1 OK  
-18 volts  $\Rightarrow$  18.2 OK  
+15 volts  $\Rightarrow$  OK  
-15 volts  $\Rightarrow$  OK

SEA ICE EXPERIMENT  
SITE DESCRIPTION

SITE 2:

LOOK INFORMATION:

	LOOK #1	LOOK #2	LOOK #3	LOOK #4	LOOK #5	LOOK #6
DATE:	5-17-77	5-17-77	5-17-77	5-18-77	5-18-77	5-18-77
TIME: START END	8:45 am 10:30 am	2:30 pm 3:30 pm	4:55 pm 5:45 pm	8:45 am 9:45 am	11:00 am 11:30 am	4:00 pm 5:00 pm
AIR TEMP: START END	-2°C -2°C	--- -0.5°C	--- 0°C	-5°C ---	--- ---	--- ---
ICE SURFACE TEMP: START END	-4°C ---	--- ---	--- ---	--- ---	--- ---	--- ---
DELAY LINE TEMP: START END	--- -2°C	8°C ---	--- 12°C	-5°C ---	--- ---	--- ---

COMMENTS:

LOOK #1: "multiyear ice"



Looking into bottom of ridge, undisturbed snow cover, and set done approximately 40.0 cm at pivot point. Calibration done at end of look.

All surfaces undisturbed snow.

LOOK #2: Angles 3' to pivot.

Looking at first faces of hummocks.

2½ meters from previous site.

Skipped L-Band cross pol

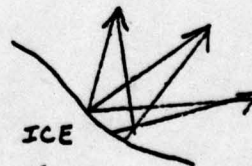

LOOK #3: Measuring return from peak.

Distance back 151 cm.

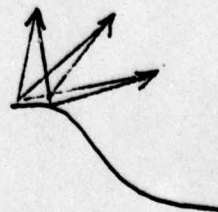

LOOK #3: 1 - 1.20 1100MHz  
 2 - 2.35  
 3 - 3.5  
 4 - 4.66  
 5 - 5.85  
 6 - 6.90  
 7 - 8.15  
 8 - 9.3  
 9 - 10.45

LOOK #4:

parallel

⊥

KuX -- peak

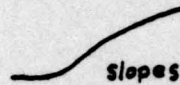

L --

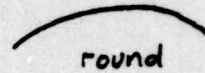

20° questionable due to hump for L-Band. KuX alright.

LOOK #5:

parallel

⊥

KuX --



L --

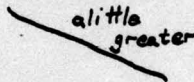

20° erroneous L-Band

LOOK #6: Bare ice surface of multiyear.

Slope in azimuth left to right →.

Surface reasonably rounded and smooth as seen by eye.

KuX -- HH HV

L -- VV

1400 MHz

SEA ICE EXPERIMENT  
SITE DESCRIPTION

SITE 3

LOOK INFORMATION:

	LOOK #1	LOOK #2	LOOK #3	LOOK #4	LOOK #5	LOOK #6
DATE:	5-19-77	5-19-77	5-20-77	5-20-77	5-20-77	5-21-77
TIME: START END	10:00 am 12:30 pm	2:00 pm ---	10:00 am 11:00 am	2:15 pm 2:45 pm	5:00 pm 6:00 pm	9:45 am 10:30 am
AIR TEMP: START END	---	---	-9°C ---	-10.5°C ---	-10°C ---	-10°C ---
ICE SURFACE TEMP: START END	---	---	-4.5°C ---	---	-10°C ---	-6°C ---
DELAY LINE TEMP: START END	---	---	16°C ---	2°C 4°C	---	-10°C ---

COMMENTS:

LOOK #1: Surface smooth--data appeared to have mirror effect.  
 1) Generator acting funny. Causing fluctuations.  
 2) Delay line levels seemed low on KuX; alright L-band.  
 3) Look at data closely.  
 4) Lens calibration done at 12:00 and everything appeared alright.

MAY 19  $\Delta f$  volts set at 0.96 volts reset to 1 volt.  
 Spectrum set to 50kHz.

KuX Fm  $\Rightarrow$  7.4x.5:msec bottom  
 L Fm  $\Rightarrow$  5.35x.5:msec bottom

KuX freq 1 d1  $\Rightarrow$  19.33  
 L d1  $\Rightarrow$  27.39

KuX  $\Delta f$  1v p-p  
 DAC set OK  
 Spectrum reset to 48kHz.  
 L -- d1  $\Rightarrow$  28.06  
 KuX Fm  $\Rightarrow$  7.7x.5:msec  
 L Fm  $\Rightarrow$  5.8x.5:msec  
 KuX  $\Rightarrow$  19.6

LOOK #3: Calibration reset right before. Everything remaining well.  
1) KuX DAC 1-9 OK  
2)  $\Delta f$  KuX - 1000 MHz  
3) Fm reset

LOOK #5: Along plate direction.

SEA ICE EXPERIMENT  
SITE DESCRIPTION

SITE 4:

LOOK INFORMATION:

	LOOK #1	LOOK #2
DATE:	5-21-77	5-22-77
TIME: START END	3:00 pm 4:00 pm	9:00 am 9:45 am
AIR TEMP: START END	-8.0°C -8.0°C	-11.0°C -11.0°C
ICE SURFACE TEMP: START END	-5.0°C -5.0°C	-7.0°C -7.0°C
DELAY LINE TEMP: START END	-10.0°C -10.0°C	-3.0°C -3.0°C

COMMENTS:

LOOK #1: Category--Pressure Ridge

- 1) Took separate looks at ridge for L and KuX
- 2) 20° for L band erroneous; horn looking too low into ridge

LOOK #2: Thick first year ice on both sides of the ridge.  
Very much brine in first year ice.

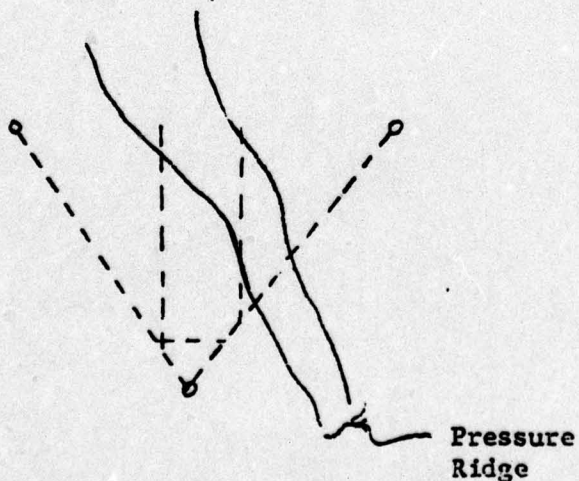

SEA ICE EXPERIMENT  
SITE DESCRIPTION

SITE 5

LOOK INFORMATION:

	LOOK #1	LOOK #2	LOOK #3	LOOK #4	LOOK #5	LOOK #6
DATE:	5-22-77	5-23-77	5-23-77	5-23-77	5-23-77	5-23-77
TIME: START END	3:00 pm 4:30 pm	9:00 am 10:00 am	10:30 am 11:00 am	11:30 am 12:00 am	4:00 pm 5:00 pm	--- ---
AIR TEMP: START END	-6°C -6°C	-6°C ---	-6°C ---	--- ---	--- ---	--- ---
ICE SURFACE TEMP: START END	-5°C -5°C	-4°C -4°C	-4°C -4°C	--- ---	--- ---	--- ---
DELAY LINE TEMP: START END	-2°C 2°C	-2°C 2°C	6°C 12°C	12°C 18°C	8°C 10°C	--- ---

COMMENTS:

- LOOK #1: 1) Put oil in generator.  
2) DAC-02-shift in #6 position on previous multiyear ice.  
3) Calibration done here at grazing then at 30°. 30° works best.

- LOOK #2: 1) Site #1

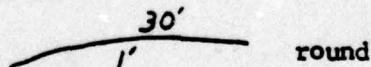

Recorded in Weeks Memo.

- 2) Site #2

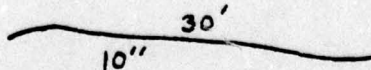
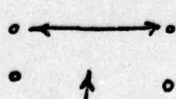

- 1--fairly flat  
KuX--slight roll  
3) Multiyear.

LOOK #3: 1) Multiyear  
2) KuX



3) L Band

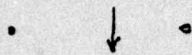

LOOK #4: 1) Multiyear



KuX--slight  
L--slight

LOOK #5: 1) Multiyear

2)

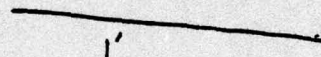

KuX 6\"/>

3) #6 5:3-

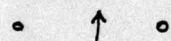
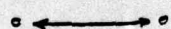

straight 1' slope  
slight down grade for both

LOOK #6: 1) Multiyear

2) Did not do cross pole on last leg #4.

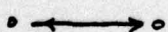

straight slope 1'   
slight down grade for both KuX and L

SEA ICE EXPERIMENT  
SITE DESCRIPTION

SITE 6: EMIKPUK LAKE

Site at bare ice area approximately 200 meters East of the NARL side of the lake. Ice thickness was 6 feet 6 inches.

SALINITY SAMPLES:

1 - 4 cm	#69
5 - 14 cm	#4
14 - 20 cm	#93
badly disced area (can't use)	
42 - 50 cm	#12
55 - 65 cm	#17
78 - 85 cm	#11

We cored on to approximately 180 cm but were unable to get good core (ice wet below 90 cm).

CORE:

CONTAINER #	LENGTH (cm)	DEPTH (cm)	COMMENTS	
16	9	9	Lake Ice	
99	11	20		
33	12	32		
20	12	44		
10	11	55		
5	10	65		
8	10	75		
98	12	87		
3	10	97		
14	14	111		
6	11	122		
66	12	134		
9	13	147		Sea Ice - brine
115	5	152		
7	12	164		
18	12	176		
39	9	185		
74	5	190		
2	8	198		
116	10	208		

Does look in TS as having small amount of brine in top layers also. Not as noticeable as bottom layering where this effect is noticeable by the eye.

## LOOK INFORMATION:

	LOOK #1	LOOK #2	LOOK #3	LOOK #4	LOOK #5
DATE:	5-25-77	5-25-77	5-26-77	5-26-77	5-26-77
TIME: START END	2:15 pm 3:00 pm	4:00 pm 5:00 pm	10:20 am ---	2:10 pm 3:00 pm	4:00 pm 5:00 pm
AIR TEMP: START END	-2°C -2°C	2°C 2°C	-2°C -2°C	0°C 0°C	--- ---
ICE SURFACE TEMP: START END	-.8°C -.3°C	-.5°C -.5°C	-1°C -1°C	-2°C -2°C	-1°C -1°C
DELAY LINE TEMP: START END	--- ---	--- ---	--- ---	6°C 6°C	13°C 16°C

## COMMENTS:

- LOOK #1: 1) Broken cable to KuX antenna; fixed and repaired.  
 2) KuX lens #1 = +5.7 dBm  
 L Band = +9.2 dBm  
 3) Realigned antennas.

LOOK #3: Pivot point set 2½ feet.

LOOK #4: Lake Ice -- Composed of areas of white cotton forms. Cracks are small and under centimeter buckles. A few jumps greater than one centimeter. Green areas with circular balls under ice a few centimeters.

SEA ICE EXPERIMENT  
SITE DESCRIPTION

SITE 7: MEADOWLAKE

This lake is shallow, 74 cm deep, at the test site. It is frozen to the bottom where there is hard frozen dirt (mud). The lake is supposed to be fresh water, no salt. The surface is mirror smooth with visible hairline cracks but no irregularities in surface height. Snow cover is approximately 13 cm deep.

SNOW DENSITIES:

Container #	Distance from surface to container center	Weight*
2	3 cm	500 gm
3	9 cm	512 gm
4	14 cm	512 gm
5	15 cm	496 gm

\*weight of container and snow

CORE:

0-10 cm #121	30-40 cm #13
10-20 cm #108	40-50 cm #1
20-30 cm #110	50-63 cm #152

LOOK INFORMATION:

	LOOK #1	LOOK #2	LOOK #3
DATE:	5-23-77	5-23-77	5-23-77
TIME: START END	9:45 am 10:20 am	2:05 pm 3:00 pm	4:00 pm 5:00 pm
AIR TEMP: START END	0°C 2°C	2°C 2°C	4°C 4°C
ICE SURFACE TEMP: START END	0°C 0°C	0°C 0°C	-0.5°C -0.5°C
DEWY LINE TEMP: START END	2°C 7°C	10°C 14°C	14°C 21°C

## COMMENTS:

LOOK #1: snow cover 17 cm and snow temp 0°C.  
LOOK #2: snow cover 17 cm and snow temp 0°C.  
LOOK #3: snow cover 17 cm and snow temp -0.5°C.

APPENDIX D

PART II

Friday, 13 May 1977: 300' overcast, warm, approximately 20°F.

Checked out cold room near lab, looks o.k.

Moved equipment into cold room, unpacked, microtome all rusted, plus bolts frozen.

Calibrated thermometers. The corrections are added to readings to give

true value. For example:  $-12.0^{\circ}$  (observed)  
 $+ 2.0^{\circ}$  (correction on thermometer)  
 $-10.0^{\circ}$  (actual)

#1. +1.0°C	#4. +3.8°C
#2. +1.8	#5. +2.6
#3. +0.5	#6. +12.0

Weighed rusty snow density tubes:

#1. 308 g	#7. 286 g
#2. 292	#8. 406 g
#3. 288	#10. 312
#4. 288	#11. 408
#5. 284	#12. 412

Kansas equipment arrives.

Prepared salinity containers. Reasonably ready to go.

Whaling movie in the evening.

Dwayne Bostow is the person at the Geophysic Institute, University of Alaska, that handles the Automax comeras.

Bill Zito - electronics technician working with Shapiro.

Saturday, 14 May 1977: Overcast, light winds, air temperature = 20°F.

Moved microtome blade.

Need: Shovel, hacksaw blade, masking tape.

Radar will be ready to go by the afternoon.

Worked on PET write-up.

Set up radar just off NARL and installed antennas (L-band).

Scouted multiyear frags:

65° to nearest

80° to other, a very good example

Sunday, May 15 1977: Colder,  $V_a = 8$  knots, light drifting snow.

Roll #1.

PX1 Snow surface at Radar Site 1 (R1) Surface composition of pans ~ 2-3 m

in diameter. Some minor relief 2 cm at edges

0945 pans

Air temperature =  $-7.0^{\circ}\text{C}$

Snow surface temperature =  $-6.0^{\circ}\text{C}$

Ice surface temperature =  $-5.5^{\circ}\text{C}$

Very nice compact temperature unit

Omega Engineering, Inc.

Stanford, CT

Get one:  $-45^{\circ}$  to  $+20^{\circ}\text{C}$

Site R1-1

Antenna point  $130^{\circ}$  mag

1100

Air temperature =  $-6.0^{\circ}\text{C}$

Snow surface =  $-4.0^{\circ}\text{C}$

PX-2,3; photos of radar system

PX-4 Snow roughness of L area

PX-5 Snow roughness of X-area

11.0 cm of snow

Temperature at snow-ice interface =  $-4.0^{\circ}\text{C}$

Site R1-2 oriented at  $70^{\circ}$  mag

Snow density at L-band

#3. 7 cm sitting on ice, 426 g.

#5. 4 cm, 440 g.

X 8 cm of snow

#5 at 4.5 cm = 434 g.

Ice surface condition:

X- flat except for 1 ea 4 cm high and 5 cm wide raised area = edge of a pancake, oriented  $148^{\circ}$  mag

L- flat except for 4 cm high raised block, approximately 10 cm wide, sharp corner on block.

Ice thickness:

L- 5'5"

X- 5'4½"

Core:

5 cm - 4.0

20 cm - 3.3

50 cm - 3.2 or -2.0 surface

164 cm = bottom of core -2.2 surface

Sal:		
0-10	#10	7.4
10	# 1	3.3
20	2	4.5
30	69	5.3
40	115	5.8
50	12	6.8
60	33	4.5
70	66	4.0
80	93	4.2
90	39	4.7
100	9	5.0
110	7	5.2
120	5	4.2
130	74	5.0
140	32	6.5
150	17	6.5
160-64	8	14.1

Site R1-3 oriented at 20° mag

The upper part of core was slush ice, circular bubbles, approximately =  
rand oriented; 22 cm of slush ice.

Moved sampling to Site R1-2

PX6 Photo of snow surface with scale, very flat.

Ice surface = rolling, amplitude 4 cm, wavelength 30 cm

1430

Air temperature = -4.2°C

Snow-ice interface = -5.8°C

Snow thickness = 12-14 cm

3-5 cm #3 476 g

11.0 cm #5 432 g (on ice surface 14 cm)

Core: (Base of slush at 24 cm)

0-10 #6 8.0

10 15 3.2

20 16 4.0

30 4 4.1

40 11 5.5

50 3 4.6

60-68 14 6.9

Now sampling Site R1-3:

Roughness:

Snow surface = perfectly flat

Snow thickness variable 6-8 cm

3 cm #3 432 g depth hoar

R1-4: Azimuth =  $310^{\circ}$

Batteries dead on winch, stopped for day at 1700.

Monday, 16 May 1977:

Air temperature =  $20^{\circ}$ , windy, overcast, some holes

Did salinities 0800-1000

Site R1-4 oriented at  $300^{\circ}$  mag. Description of this site follows:

Snow surface is perfectly flat

Snow h = uniform, 11.5 cm

Ice surface is flat, with occasional undulation, max roughness = 1 cm

Snow dens:

3.2 cm #1 482 g

7.5 cm #4 442 g (resting approximately on ice)

Snow-ice interface =  $-4.0^{\circ}\text{C}$

Sal. cont. #15 = 13.1% scrapings of 1 mm of upper ice surface

Took core for T.S.

23.5 cm of slush

Total length of core = 61 cm

Site R1-5 oriented at  $250^{\circ}$  mag No detailed observations here - looks like others: snow smooth and hard.

1530: Working moving system to multiyear floe fragment

Worked until 1815 on completing set-up - still not finished.

Tuesday, 17 May 1977:

Air temperature =  $24^{\circ}\text{F}$ ,  $V_a = 8-10$  knots, overcast but sun is burning through.

0800 at R2: Air temperature =  $-5.0^{\circ}\text{C}$

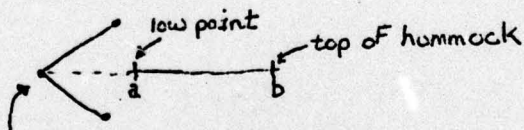

This leg is down approximately 40 cm below other two legs.

Drilled hole on flat, smooth ice just southwest of multiyear fragment

$h = \left. \begin{array}{l} 4'6'' \\ 4'6\frac{1}{4}'' \\ 4'6\frac{1}{2}'' \end{array} \right\} \text{R3 ice very uniform}$

Description of R2-1:

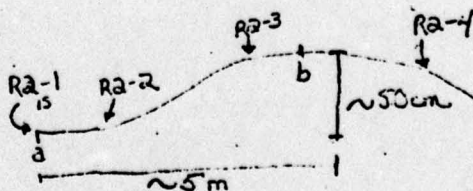

Took two photos of R2-1 - G Dome in picture

19 cm of snow-ice surface smooth and level

3 cm of hard, icy crust below snow which you can break up with a shovel.

Temperature at snow-crust interface at 1100 =  $-8.0^{\circ}\text{C}$  (air temperature =  $-2.0^{\circ}\text{C}$ )

Snow dens:

3 cm	#1	484 g
8 cm	4	460 g
12 cm	3	480 g
16 cm	2	464 g

Sample of crust in Sal container #4 = 3.2%

Crust is granular with grain size = 1 mm

Sal #11 = grab sample of snow = 1.0%

\*Below crust ice surface is flat

5 cm ice temperature =  $-3^{\circ}\text{C}$

Core:

0-10	#18	1.2%
10-21	#19	0.2
22-30	#20	0.2
30-43	#133	0.5
43-50	#121	0.6
50	#152	1.2
60	#116	1.9
70-79	#99	2.0%

Upper part of core contains spherical bubbles up to 4 mm in diameter, appear to be randomly distributed.

At approximately 55 cm change to more typical congelation ice type structure.

79-87 #110 0.9%

Took T.S. core: 107 cm long, cut off 100-107 for salinity in #116.

i.e. 100-107 cm #116 3.0%

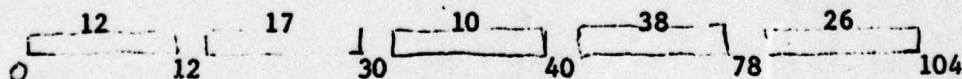

There are semi-spherical snow filled voids through the complete length of the core (notched top of segs)

Having trouble coring below 1 m.

Site R2-2 is just at start of upslope of the hummock.

Took two photos of Site R2-2. B. Onstott in photo holding marked board.

snow                      both  
ice                        smooth

Ice surface might have 4 mm of roughness.

7 cm tube 4 428 g

At snow-ice interface, temperature =  $-5.5^{\circ}\text{C}$

At 1 cm, temperature =  $-5.2^{\circ}\text{C}$

Site R2-3:

1 cm of snow

Air temperature =  $-2.0^{\circ}\text{C}$

Snow-ice temperature =  $-2.0^{\circ}\text{C}$

Quit at 1800.

Wednesday, 18 May 1977:

Windy, 20 knots, colder

Did salinities between 0745 - 0815

Description of Site #R3: very flat, uniform, unrafted first year ice,  
drilled holes yesterday here, h = 4'6" to 4'6½".

In general, 2 cm of snow over area, quite uniform in thickness.

Snow too thin to get snow density sample.

Sal #2 Snow grab sample to ice surface = 7.0%

Sal #10 Scraping of upper ice surface = 12.2%

0-10 cm	#6	7.0%
10	9	7.5%
20	7	8.0
30	14	6.5
40	1	5.5
50	45	4.0?
60	66	5.4
70	16	5.3
80-90	33	4.7
90	39	5.4
100	74	5.5
110	8	5.3
120	69	5.0
130-137	93	8.6

The bottom segment shows a pronounced c-axis orientation.

Took pictures of Site R2-5: Dome is in picture holding a metal rod and standing by leg of tripod.

R2-5 on approximately flat surface again

R2-4 was on down slope

Back at R3: first year ice oriented substructure extremely strong at approximately 90 cm.

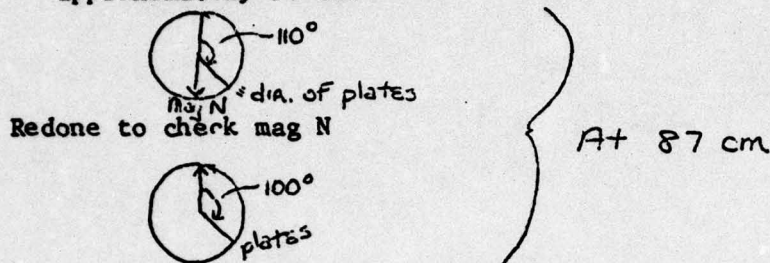

Plates approximately perpendicular to coastline

Took rest of core at 137 cm (plankton layer)  
bottom

Oriented identical to 87 cm.

Took this core back for T.S.

This site is about 1 mile offshore  
200° incinerator  
270° theatre

Description of R2-3:

effectively top of hummock; 2-3 cm of snow

Sal #5: Grab sample of snow approximately =  $\frac{1}{2}$  mm grain

Ice surface shows 3-4 mm roughness but its overall shape is rounded

Air temperature =  $-3^{\circ}\text{C}$

Snow-ice interface temperature =  $-3.5^{\circ}\text{C}$

Took soil core: Many spherical bubbles and refrozen snow slush-like sections

Inclined layers suggest the hummock was a ridge

0-10	#110	0.2%
10	152	0.2
20	11	0.2
30	19	0.6
40	18	0.2
50	15	0.4
60	99	0.7
70	133	0.8
80	12	1.9
90-100	116	1.9
100	121	1.8
110	4	1.7
120-130	108	2.0
150-160	20	1.3
164-174	120	1.4

Can clearly see block-like structures in core (this was a ridge)

Saved 130-150 cm for T.S.

Took additional cores 0-10, 10-21, 21-88.

R2-4: Photo of scaled board in snow

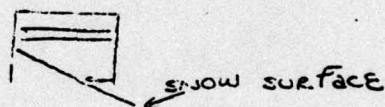

Slope is dipping away from radar beam

Snow depth approximately = 20 cm

Snow dens.

4 cm	#4	428 g
11 cm	#2	450 g
16 cm	#3	408 g

Ice surface roughness as at R2-3:

Approximately 4 mm roughness but overall is smooth

Temperature at snow-ice interface =  $-6.5^{\circ}\text{C}$

Air temperature =  $-3.0^{\circ}\text{C}$  (1600 hours)

R2-5 site largely destroyed by footprints

Snow approximately 10-13 cm

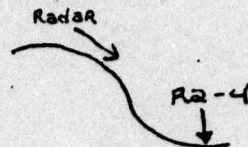

Snow appears similar to that at nearby (3 m) Site R2-4

Temperature of snow-ice interface =  $-4.0^{\circ}\text{C}$

R2-6: Surface is essentially bare ice roughness elements approximately 1 cm.

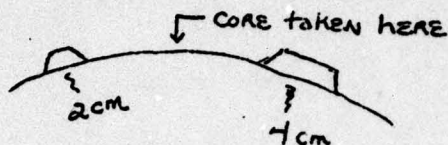

0-10	(D-out)	0.8%
10	#13	0.4
20	17	0.1
30	98	0.1
40	32	0.2
50-63	3	0.4

Thursday, 19 May 1977

Clear, windy (30 knots)

Air temperature =  $24^{\circ}\text{F}$

Did salinities in morning

Onstott and Dome working on Site R3

Went to ice in afternoon

R3-1 oriented looking  $320^{\circ}$  mag

Surface (snow-ice) temperature:  $-4.0^{\circ}\text{C}$  (1400 hours)

Air temperature =  $-5.0^{\circ}\text{C}$

Very windy

Took picture of the general site; both Onstott and Dome are in the photo.

Took picture of pressure ridge in this vicinity

Photo of edge of multiyear fragment that contains Site R2

R3-2 oriented  $355$  mag

R3-3 oriented  $050$  mag

1615 hours: Air temperature =  $-6.0^{\circ}\text{C}$ ; snow-ice temperature =  $-3.5^{\circ}\text{C}$   
The radar unit starts acting odd, bring it back for calibration  
By 2200 everything working ok  
Moore arrives approximately 2400.

Friday, 20 May 1977:

Air temperature =  $+10^{\circ}\text{F}$  (cold)

Windy, clear

Scheduled to go out with Francois and look at ice on the way

BRW declination =  $26^{\circ}\text{E}$

Took a number of photos of the multiyear floe where Francois plans to  
set up camp

Changed to film roll #2

On way back looked for multiyear

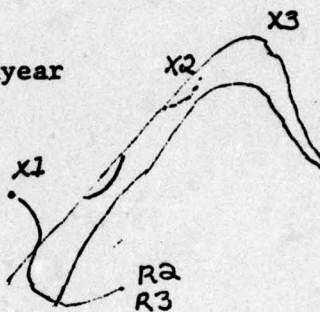

X3 should be easy to find

X1 is closest but it is in a rough area, perhaps I can find it.

R3-4 oriented  $095^{\circ}$  (approximately parallel to basal plane)

Worked on R-4: Ridge, Profile

When we worked, we screwed up site

R3-4 oriented  $10^{\circ}$  mag

Power unit went out at 1600 hours

Returned to NARL and repaired it

Saturday, 21 May 1977:

Overcast, cold ( $+8^{\circ}\text{F}$ ) moderate wind (10 knots)

R3-6 oriented  $225^{\circ}$  mag (approximately perpendicular to coast)

At 1000 hours:

Ice temperature =  $-6^{\circ}\text{C}$

Air temperature =  $-10^{\circ}\text{C}$

Went looking for another multiyear site

Site R4: 4'4½"

Moore leaves after lunch

Took 3 photos of ridge site

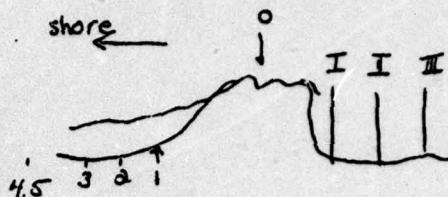

1m      43 cm snow  
2        24 cm snow  
3        10 cm snow  
4.5      5 cm snow

Ice  
4'0"  
3'7"  
3'11"  
4'4½"

0 m ridge 90 cm above undeformed surround. ice

Block in ridge either 3 m thick or approximately 10 cm thick (ridge formed in fall when ice was thin)

Air temperature = -8°C

Ice surface temperature = -5.0°C

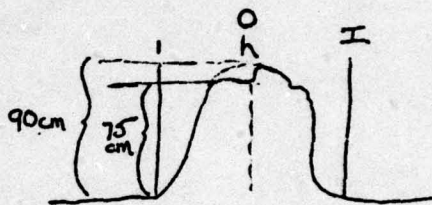

I. 12 cm of snow    5'9"

II. 17 cm of snow   5'10½"

III. 18 cm snow

0. no snow 7'5" ice (point at 90 cm above ice surface but drilled from 75 cm)

Snow density (rep. of drift)

8 cm    #3      454 g  
20 cm   #4      466 g

Moved rig approximately 5' to R4-2:

Similar to R4-1 but a few feet down the same ridge, general description of site is identical.

Worked until 1830 - it was a cold day

Went to M. Frank's in evening, made a list of things to do regarding Tin City. Party after.

Sunday, 22 May 1977:

Overcast, light winds, Air temperature = 15°F

Pleasant working conditions

Sacked in in the morning

Dome obtained a salinity core from the center of the ridge at Site R4 at approximately 1030 hours

Depth	Container	
0-6.5	#1	8.5%
6.5-16.5	10 cm of snow	
16.5-26.5	#2	6.2%
26.5-35	#3	4.4
35-44	#4	4.7
44-51	#5	6.7
51-60	#6	4.0
60-68	#7	6.3
68-77	#8	7.4
77-85.5	#9	5.3
85.5-95.5	#10	4.5
95.5-104.5	#11	7.2
bottom cm	#12	22.5 (ice deteriorated)

Total core length = 126 cm

Ice surface temperature =  $-7.0^{\circ}\text{C}$  Air temperature =  $-11.0^{\circ}\text{C}$

Finished at R4

Afternoon moved to Site R5

At 1440: Air temperature =  $-6.0^{\circ}\text{C}$ , Ice surface temperature =  $-5.0^{\circ}\text{C}$

Site is located on an old thick multiyear floe

Table 3 photos of site.

Where we are making the radar observations, there is essentially no snow on the ice surface

Ice surface itself is rough:

On a approximately less than or equal to 1 cm scale, this roughness is produced by melting, most frequent roughness about 0.5 cm.

Ice thickness greater than 3 m

No voids noted, chips dry all the way down

Took core

Radar readings taken along axis of broad dome

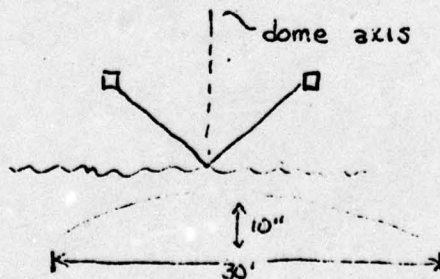

Probe ice temperatures: 5 cm =  $-6.0^{\circ}\text{C}$ ; 40 cm =  $-6.0^{\circ}\text{C}$

Depth	Container	
0-10	#13	0.75%
10-20	14	0.2
20-32	15	0.1?
32-40	16	0.2
40	17	0.2
50	18	0.4
60	19	0.4
70-79	20	0.4
79-90	32	0.6
90-100	33	0.3
100	39	1.2
110	66	0.65
120	69	1.0
130	74	0.8
140	93	0.6
150	98	0.6
160-170	99	0.6
170-180	108	0.6
180-189	110	0.55

Also took T.S. core

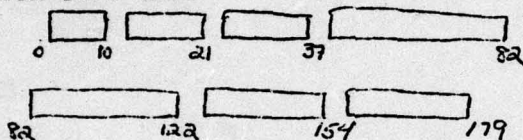

At 130 cm there is a change from layered bubbly ice to more normal sea ice. This change is not marked in the salinity core.

Monday, 23 May 1977:

Overcast, air temperature = +15°F, light winds

Did salinities

Picked up equipment at Site R5:

At 1020, air temperature = -1.0°C; ice surface temperature = -4.0°C

Started on ground truth at Site R6 - Emikpuk Lake

Selected bare ice area approximately 200 m east of NARL side of the lake

Ice thickness = 6'9"

1-4	#69
5-14	4
14-20	93
badly disced (can't use)	
42-50	12
55-65	17
78-85	11

We cored on to approximately 180 cm but were unable to get any more core  
(ice was wet after about 90 cm, water in hole)

Worked on thin section in afternoon

Did sections on R3:

TS 15 cm

TS 130 cm

Took 2 photos of TS 130 at f5.6, 1 sec.,  $\frac{1}{2}$  sec.

Then took cross polaroid photos with section oriented with N (mag) up  
and then with crystals at max brightness and at min brightness

Did fabric analysis

Mag N arrow

<u>Site R3</u>	130 cm
260	1L
258	2L
263	1R
258	1L
252	0
257	1L
262	3L
273	0
272	1R
257	2R
277	6R
268	0
284	5R
258	0
274	2L
266	0
244	8L
258	11L
265	3L
262	6L
256	2L
272	1L
277	1L
268	0
246	5R
271	2L
258	1L
254	1R
257	3R
244	2L
277	0
260	1L
270	2R

Next worked on R3 - 15 cm, not oriented.

163	5L
164	1L
147	3L
181	4L
174	0
172	3L
190	0
178	6L
158	1L
142	1L
160	3R
193	0
150	3L
171	2R
188	0
162	2L
181	0
162	4R
186	3R
167	2R
147	3L
198	3L
213	1L
166	0
175	5L
194	6L
139	5L

A difficult section to study because of small holes. Approximate direction of max extinct = 175

Approximate direction of max brightness = 230°

Took 2 photos with plain light and 2 photos with polarized light

Finished at 2000 hours

Packed in evening

Kansas group will try to do Ikoroavik Lake, S. Meadow Lake and Emikpuk

Tuesday, 24 May 1977:

Leave BRW 1000 hours via NARL C-117

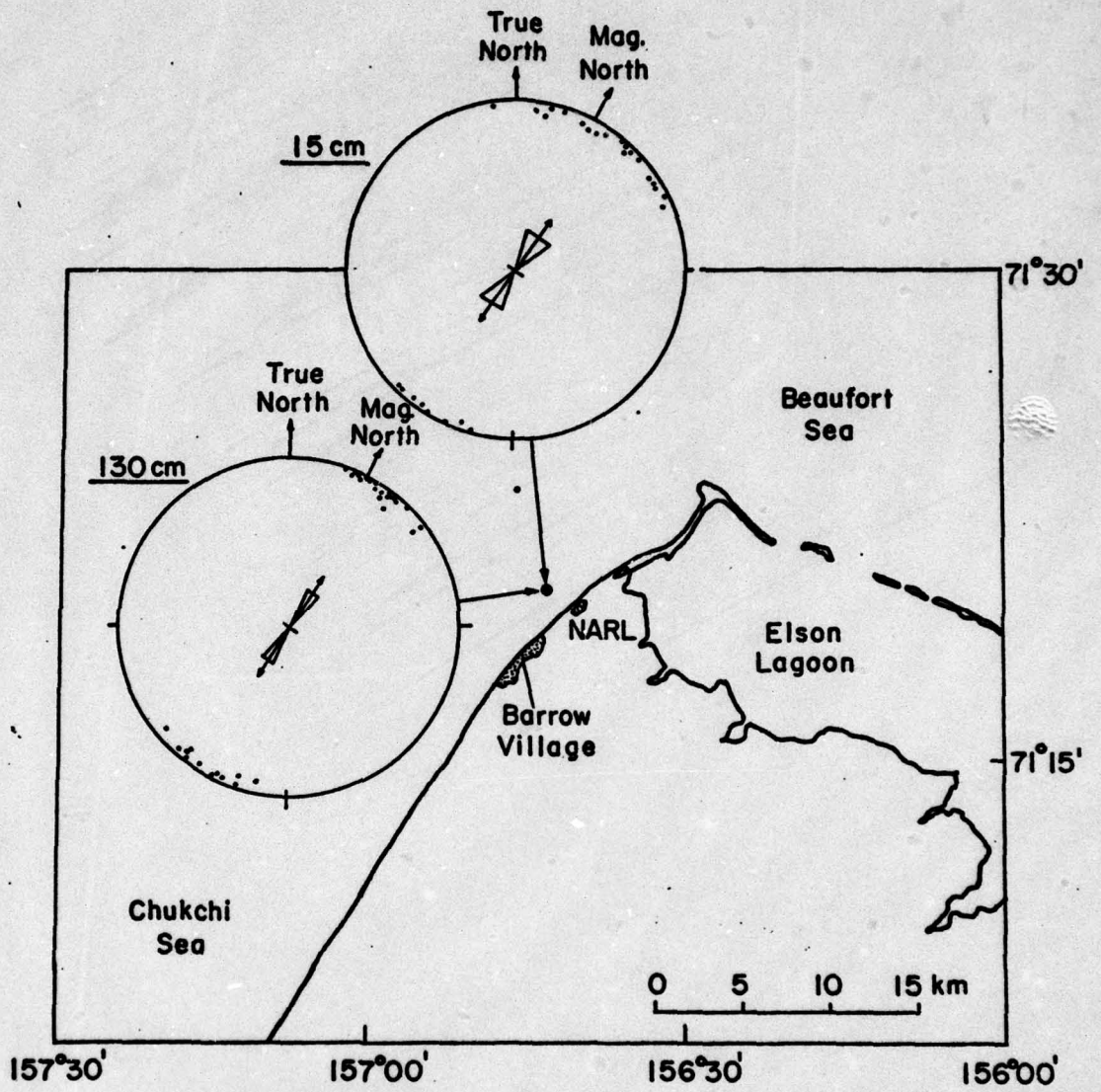

APPENDIX E. SALINITY MEASUREMENTS

SITE 1: THICK FIRST-YEAR

DEPTH (CM)	SALINITY (0/00)
0 - 10	7.4
10 - 20	3.3
20 - 30	4.5
30 - 40	5.3
40 - 50	5.8
50 - 60	6.8
60 - 70	4.5
70 - 80	4.0
80 - 90	4.2
90 - 100	4.7
100 - 110	5.0
110 - 120	5.2
120 - 130	4.2
130 - 140	5.0
140 - 150	6.5
150 - 160	6.5
160 - 164	14.1

Comments:

- (a) Salinities measured with Solu-bridge
- (b) Scraping of 1 mm upper ice surface -13.1%

SITE 2: MULTI-YEAR

DEPTH (CM)	SALINITY (0/00)
0 - 10	1.2
10 - 21	.2
22 - 30	.2
30 - 43	.5
43 - 50	.6
50 - 60	1.2
60 - 70	1.9
70 - 79	2.0
79 - 87	.9
100 - 107	3.0

Comments:

- (a) Salinities measured with Solu-bridge
- (b) Grab sample of snow = 1.0%

SITE 2 (continued): MULTI-YEAR (HUMMOCK)

DEPTH (CM)	SALINITY (0/00)
0 - 10	.2
10 - 20	.2
20 - 30	.2
30 - 40	.6
40 - 50	.2
50 - 60	.4
60 - 70	.7
70 - 80	.8
80 - 90	1.9
90 - 100	1.9
100 - 110	1.8
110 - 120	1.7
120 - 130	2.0
150 - 160	1.3
164 - 174	1.4

Look # 6

DEPTH (CM)	SALINITY (0/00)
0 - 10	.8
10 - 20	.4
20 - 30	.1
30 - 40	.1
40 - 50	.2
50 - 63	.4

SITE 3: THICK FIRST-YEAR

DEPTH (CM)	SALINITY (0/00)
0 - 10	7.0
10 - 20	7.5
20 - 30	8.0
30 - 40	6.5
40 - 50	5.5
50 - 60	4.0
60 - 70	5.4
70 - 80	5.3
80 - 90	4.7
90 - 100	5.4
100 - 110	5.5
110 - 120	5.3
120 - 130	5.0
130 - 137	8.6

Comments:

- (a) Salinities measured with Solu-bridge.
- (b) Snow grab sample to ice surface = 7.0%.
- (c) Scraping of upper ice surface = 12.2%.

SITE 4: PRESSURE RIDGE

DEPTH (CM)	SALINITY (0/00)
0 - 6.5	8.5
6.5 - 16.5	6.2
26.5 - 35.0	4.4
35.0 - 44.0	4.7
44.0 - 51.0	6.7
51.0 - 60.0	4.0
60.0 - 78.0	6.3
68.0 - 77.0	7.4
77.0 - 85.5	5.3
85.5 - 95.5	4.5
95.5 - 104.5	7.2
120.0 - 126.0	22.5

Comments:

- (a) About 16 cm down had 10 cm soft snow layer - probably didn't core. Figured in above.
- (b) Salinities measured with Solu-bridge.

SITE 5: MULTI-YEAR

CONTAINER NUMBER	DEPTH (CM)	SALINITY (0/00)
13	0 - 10	.75
14	10 - 20	.20
15	20 - 32	.10
16	32 - 40	.20
17	40 - 50	.20
18	50 - 60	.40
19	60 - 70	.40
20	70 - 79	.40
32	79 - 90	.60
33	90 - 100	.30
39	100 - 110	1.20
66	110 - 120	.65
69	120 - 130	1.00
74	130 - 140	.80
93	140 - 150	.60
98	150 - 160	.60
99	160 - 170	.60
108	170 - 180	.60
110	180 - 189	.55

Comments:

- (a) Measured using Solu-bridge (under 1 to .05 increment and above 1 to .1 increment).

SITE 6: LAKE ICE (6'6")

DEPTH (CM)	CONDUCTIVITY RATIO	NOMINAL SALINITY
0 - 9	.00279	.097
9 - 20	.00221	.078
20 - 32	.00048	.040
32 - 44	.00046	.040
44 - 55	.00038	.038
55 - 65	.00034	.036
65 - 75	.00029	.036
75 - 87	.00037	.038
87 - 97	.00039	.038
97 - 111	.00045	.038
111 - 122	.00105	.051
122 - 134	.00145	.059
134 - 147	.00391	.118
147 - 152	.00447	.133
152 - 164	.00018	.068
164 - 176	.00241	.082
176 - 185	.00228	.080
185 - 190	.00214	.075
190 - 198	.00576	.165
193 - 208	.00232	.080

Comments:

- (a) Chlorinity - 19.374      Salinity - 35.00007      Air Temperature = 23°C  
 CR - 1.000
- (b) Salinities measured using Bechman

SITE 7: LAKE ICE

DEPTH (CM)	CONDUCTIVITY RATIO	NOMINAL SALINITY
0 - 10	.00150	.062
10 - 20	.00064	.042
20 - 30	.00034	.036
30 - 40	.00040	.038
40 - 50	.00113	.053
50 - 68	.00060	.042

Comments:

- (a) Chlorinity - 13.374      Salinity - 35.00007  
Conductivity Ratio - 1.0000      Air Temperature - 23° C
- (b) Salinities measured using Bechman

APPENDIX F. THIN SECTION LOCATION LOG

Site 1: (first-year pancake ice)

(a) 61 cm of solid ice core

(b) 23.5 cm of slush ice

(c) Thin sections, T5, taken at 10 cm, 51 cm

Site 2: (Multi-year)

Core 1

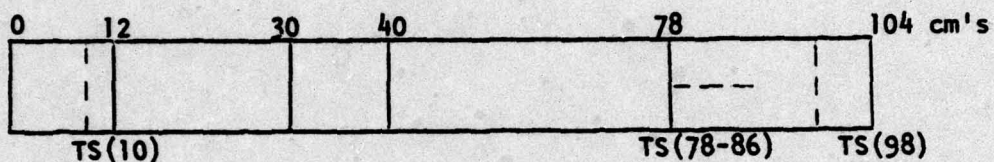

Core 2 (Hummock)

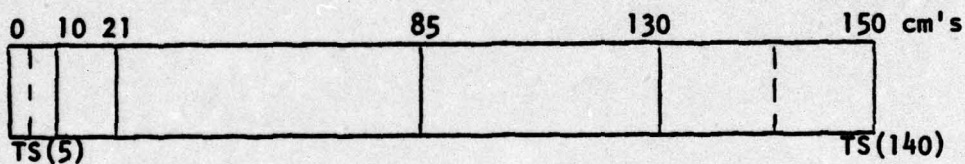

Site 3: (first year - smooth surface, structure with current)

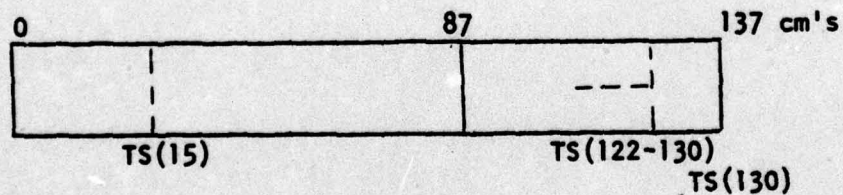

Site 5: (Multi-year)

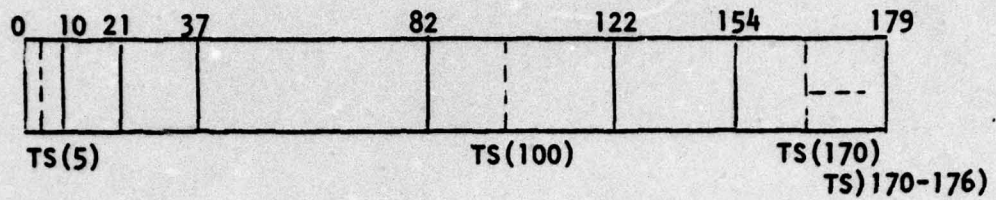

- (a) 0-14 cm: Heavy population of air bubbles
- (b) 14-124 cm: Medium population of air bubbles
- (c) 124-179 cm: Relatively few air bubbles

Site 6: (Lake Emikpuk - sea ice substructure)

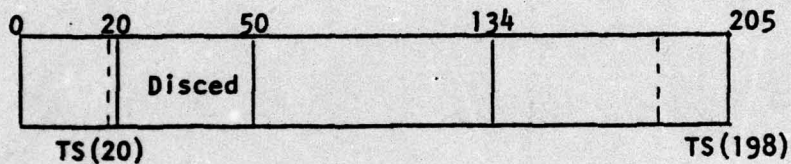

- (a) Ice wet below 30 cm
- (b) 0 - 134 cm. appearance of lake ice structure
- (c) 134 - 205 cm. appearance of sea-ice structure

Site 7: (Lake South Meadow - frozen to bottom)

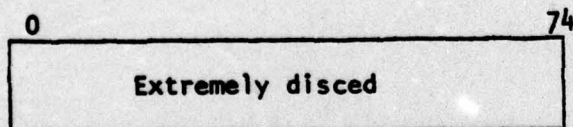

APPENDIX G. GROUND TRUTH PHOTO LOG FOR CORES AND THIN SECTIONS

<u>FRAME NUMBER</u>	<u>COMMENTS</u>
RS - 1 Site 1	0 - 20 cm
2 Site 1	0 - 22 cm
3 Site 1	22 - 44 cm
4 Site 1	44 - 64 cm
5 Site 1	1 - 10 cm
6 Site 1	19 - 30 cm
7 Site 2	0 - 23 cm: Core 1
8 Site 2	23 - 44 cm
9 Site 2	44 - 67 cm
10 Site 2	67 - 90 cm
11 Site 2	90 - END
12 Site 2	Entire Core
13 Site 2	Entire Core
14 Site 2	Top layer showing bubbles
15 Site 2	0 - 22 cm: Core 2 - Hummock-shows bubbles
16 Site 2	22 - 44 cm: shows layering
17 Site 2	44 - 66 cm.
18 Site 2	66 - 89 cm: shows stratification
19 Site 2	89 - END: shows stratification
20 Site 2	Entire core
21 Site 2	97 - 102 cm
22 Site 3	0 - 23 cm: first year-shows
23 Site 3	23 - 46 cm: effects of current on
24 Site 3	47 - 70 cm: ice formation

<u>FRAME NUMBER</u>			<u>COMMENTS</u>
RS - 25	Site 3	70 - 93 cm	
26	Site 3	93 - 106 cm	
27	Site 3	106 - END	
28	Site 3	Entire core	
29	Site 5	Entire core:	Furthest away in photo is top
30	Site 5	0 - 23 cm	
31	Site 5	23 - 45 cm	
32	Site 5	46 - 67 cm	
33	Site 5	67 - 90 cm	
34	Site 5	90 - 113 cm	
35	Site 5	113 - 135 cm	
36	Site 5	137 - 157 cm	
R4 - 0	Site 5	Dome	
1	Site 5	157 - 180 cm	
2	Site 5	180 - END	
3	Site 6	Ice surface - Emikpuk Lake	
4	Site 6	Ice surface - Emikpuk Lake	
5	Site 6	Coring and drilling - Dome and Hand	
6	Site 6	Ice surface - Emikpuk Lake	
7	Site 6	Complete core	
8	Site 6	Comparison of pure and brine sections	
9	Site 6	Bottom few cm's	
10	Site 6	Top 0 - 9 cm's	
11	Site 6	9 - 20 cm's:	Represents 9 - 134 cm

FRAME NUMBERCOMMENTS

12	Site 6	Bottom few cm's: Represents 134 - 205 cm
13	Site 6	TS6 - 198 cm
14	Site 6	TS6 - 198 cm polarized
15	Site 6	TS6 - 20 cm
16	Site 6	TS6 - 20 cm polarized
17	Site 6	TS6 - 198 cm
18	Site 6	Ts6 - 198 cm polarized
19	Site 6	TS1 - 10 cm
20	Site 6	TS1 - 10 cm polarized
21	Site 6	TS1 - 51 cm
22	Site 6	TS1 - 51 cm polarized
23	Site 6	TS2.1 - 10 cm
24	Site 6	TS2.1 - 10 cm polarized
25	Site 6	TS2.1 - 99 cm
26	Site 6	TS2.1 - 99 cm polarized
27	Site 6	TS2.1 - 78 cm: Vertical Section
28	Site 6	TS2.1 - 78 cm polarized
29	Site 6	TS2.2 - 5 cm
30	Site 6	TS2.2 - 5 cm polarized
31	Site 6	TS2.2 - 140 cm
32	Site 6	TS2.2 - 140 cm polarized
33	Site 6	TS3 - 15 cm
34	Site 6	TS3 - 15 cm polarized
35	Site 6	TS3 - 130 cm
36	Site 6	TS3 - 130 cm polarized

<u>FRAME NUMBER</u>	<u>COMMENTS</u>
R5 - 1	TS3 - 122 cm vertical
2	TS3 - 122 cm polarized
3	TS5 - 5 cm
4	TS5 - 5 cm polarized
5	TS5 - 100 cm
6	TS5 - 100 cm polarized
7	TS5 - 170 cm
8	TS5 - 170 cm polarized
9	TS5 - 170 cm vertical
10	TS5 - 170 cm polarized
11	TS6 - 20 cm
12	TS6 - 20 cm polarized
13	TS6 - 198 cm
14	TS6 - 198 cm polarized
15	Use of microtone
16	Use of microtone
17	Use of microtone
18	Microtone and thin section
19	Soft light sorree with polarized filter
20	Soft light sorree with polarized filter
21	Use of Beckman salinometer

PATENT PERS. NEGATIVE

INSERT MEMULSION SIDE DOWN

FILED

KODAK PLUS X PAN FILM

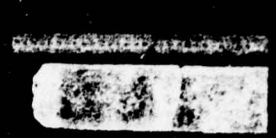
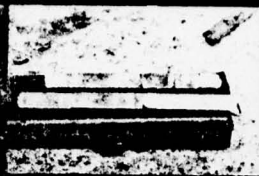

KODAK SAFETY FILM 5062

KODAK PLUS X PAN FILM

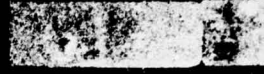
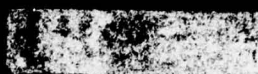
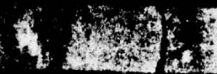
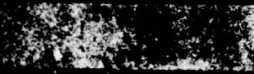

KODAK SAFETY FILM 5062

KODAK SAFETY FILM 5062

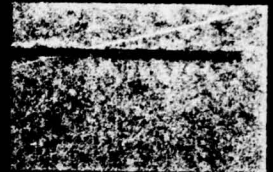

→0 →0A

→1 →1A

→2

→2A

→3

→3A

KODAK SAFETY FILM 5062

KODAK SAFETY FILM 5062

KODAK SAFETY FILM 5062

KC



→4 →4A

→5 →5A

→6

→6A

→7

→7A

KODAK SAFETY FILM 5062

KODAK SAFETY FILM 5062

KODAK SAFETY FILM 5062

KOI

→8 →8A

→9 →9A

→10

→10A

→11

→11A

KODAK SAFETY FILM 5062

KODAK SAFETY FILM 5062

KODAK SAFETY FILM 5062

K

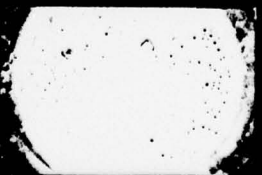
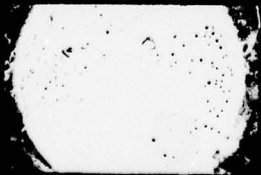

→12 →12A

→13 →13A

→14

→14A

→15

→15A

KODAK SAFETY FILM 5062

KODAK SAFETY FILM 5062

KODAK SAFETY FILM 5062

K

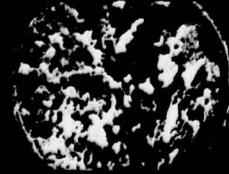

→16 →16A

→17 →17A

→18

→18A

→19

→19A

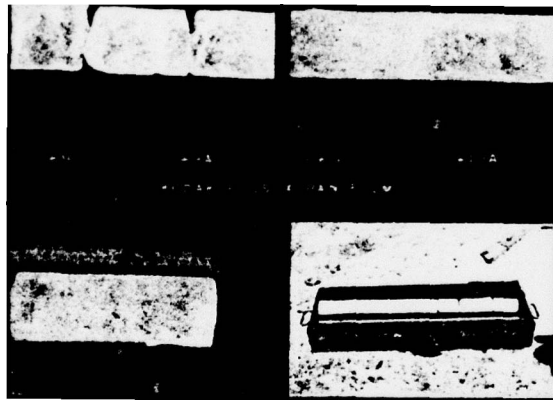

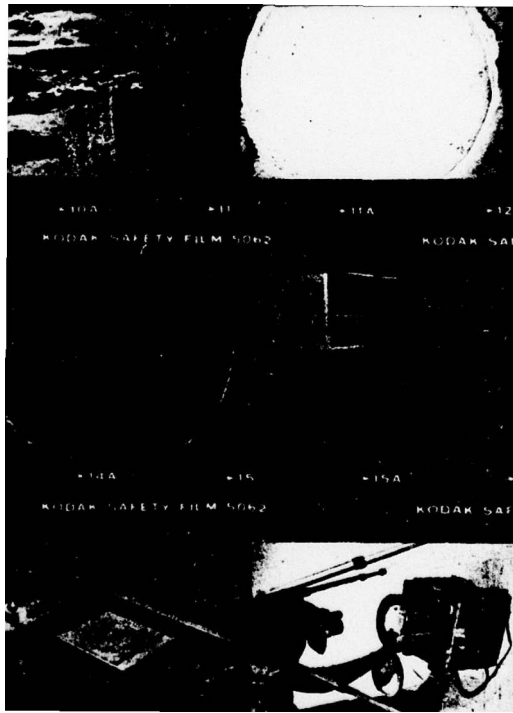

APPENDIX H. ASSEMBLY INSTRUCTIONS

## ASSEMBLY INSTRUCTIONS

### I. Assemble Main Frame

- A. Place Apex in desired location.
- B. Bolt sections 2R and 2X to respective ends of apex.
- C. Bolt sections 3r and 3x to respective ends of 2R and 2X.
- D. Use measuring rope to set proper separation of base plates.
  1. Make measurement between protruding bolts on the inside hinges
  2. For correct measurement, stretch rope and allow it to relax; relaxed length is the proper distance.
  3. Set plates in position by inserting pegs into ice through the holes in the plates.
- E. Place reflector plate on section 2R.

### II. Erect Back Pole

- A. Slide together sections 1 and 2 of back pole, thread plain end of long cable through these sections.
- B. Place these sections through pole guides on apex such that the center of section 2 rests on the main apex cross member.
- C. Thread cable through section 3 and slide it onto Sec. 2  
The entire pole should now rest on the end of Sec. 3 and the center of Sec. 2.
- D. Locate the winch plate underneath the end of Sec. 3 such that the pivot shaft rests in the bracket on the winch plate.
- E. Use the short cable (hooked into winch) to pull the winch plate up to a point 2 feet away from the support bracket. Place the cable's hook on the rod provided on the apex support bracket.

F. Peg down the winch plate and remove short cable from winch.

**III. Raise Main Frame and Place Solenoid Mechanism in Place**

A. Hook lower end of long cable into winch and take up the slack.

B. Hook the carabiner end of the cable into the U. Bolt located on the pole guides.

C. Raise the main frame to approximately 20 degrees.

D. Place solenoid mech. in place as shown in drawing.

E. Adjust main frame position until it rests on the first angle stop.

F. Relocate the carabiner to the small rod at the top of the solenoid mechanism.

**IV. Place the KuX band, L band, and equipment boxes in proper locations on the main frame.**

**V. Raise and Lower Main Frame as Necessary**

A. Unwrap solenoid emergency cord prior to raising the main frame.

B. Activate the solenoid as necessary to lower frame past any angle stop.

**VI. To DISSEMBLE Follow Above Procedure in Reverse Order.**

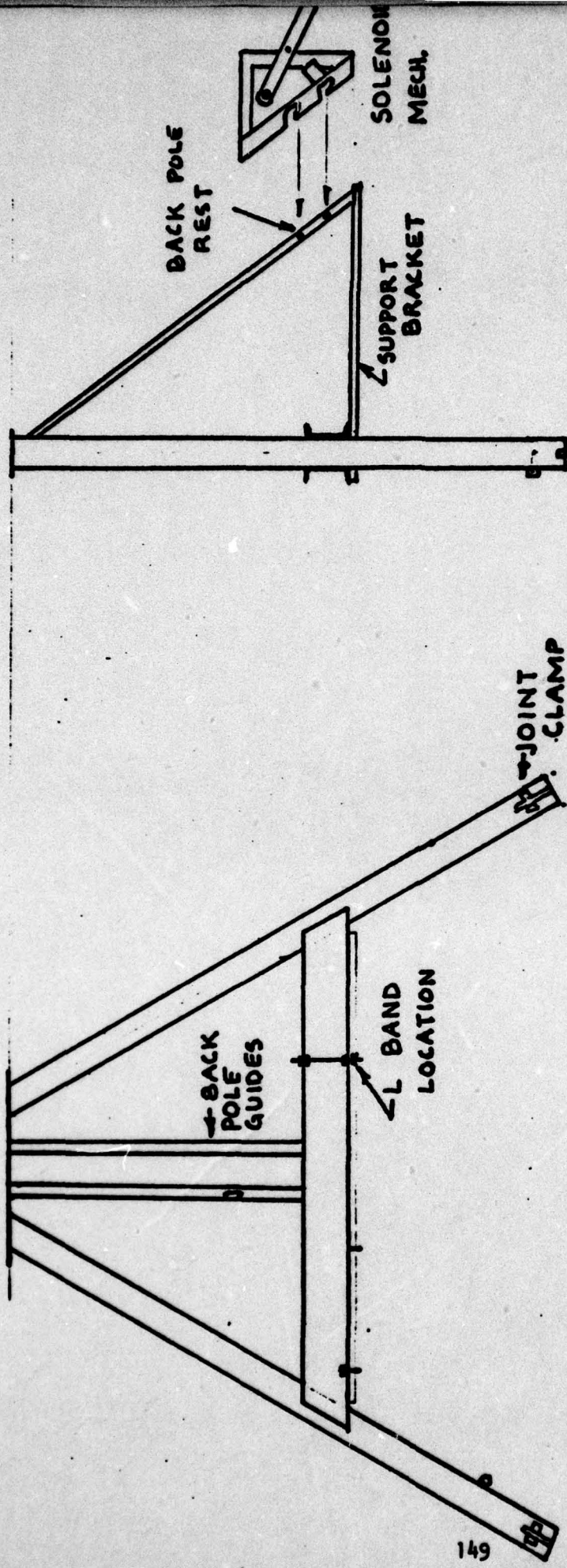

R. SIDE

X SIDE

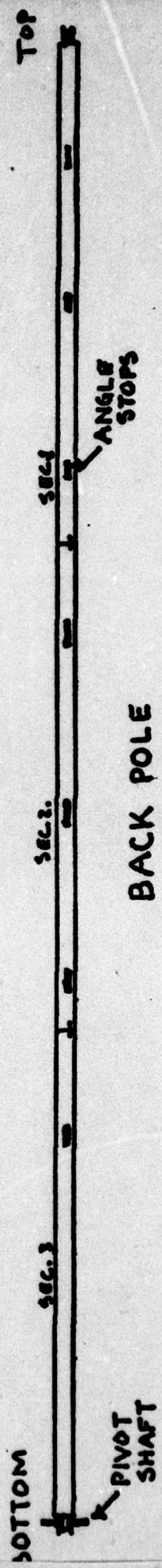

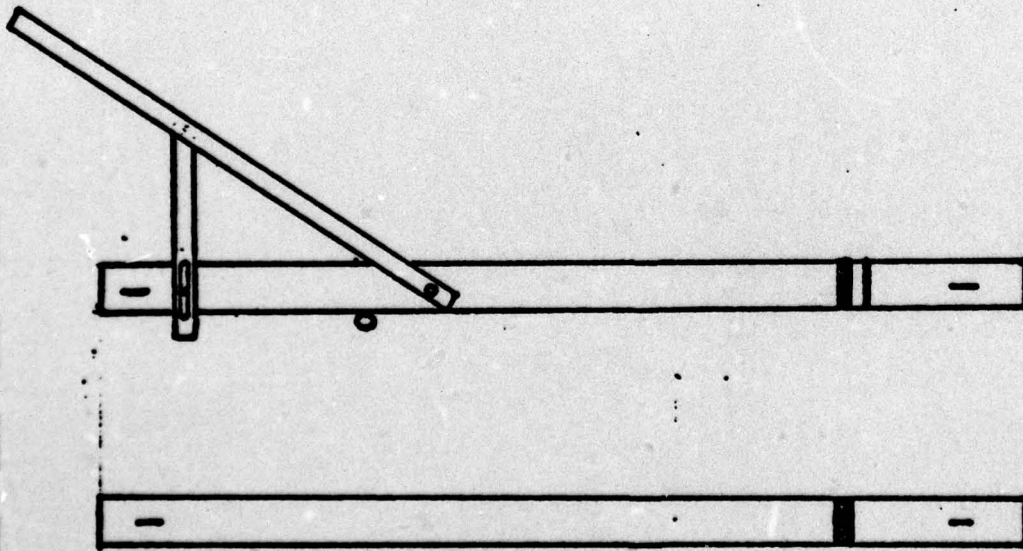

SEC. 2X SEC 2R

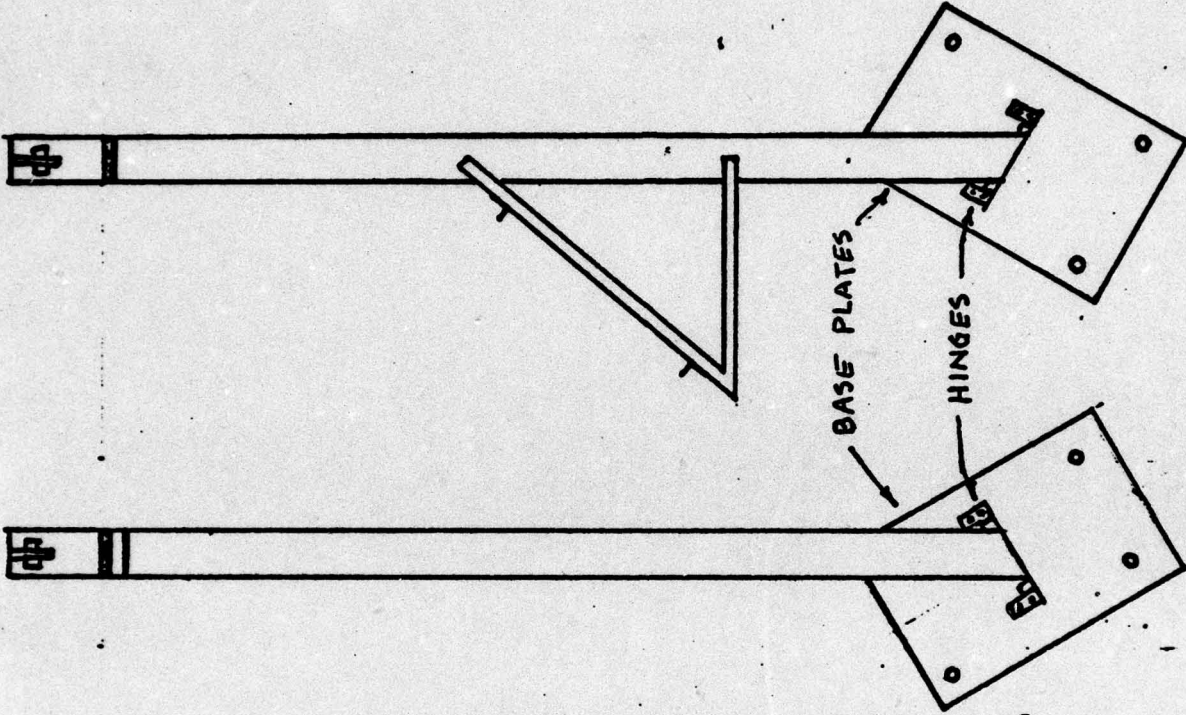

SEC. 3R

SEC 3X

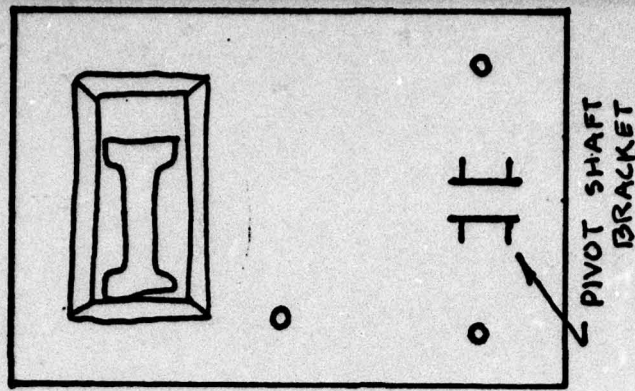

WINCH PLATE

**CRINC LABORATORIES**

**Chemical Engineering Low Temperature Laboratory**

**Remote Sensing Laboratory**

**Flight Research Laboratory**

**Chemical Engineering Heat Transfer Laboratory**

**Nuclear Engineering Laboratory**

**Environmental Health Engineering Laboratory**

**Information Processing Laboratory**

**Water Resources Institute**

**Technical Transfer Laboratory**

**Air Pollution Laboratory**

**Satellite Applications Laboratory**