

AD NO. 052809
DDC FILE COPY

28 AFML TR-77-102 19

2
F

6 EXPLORATORY DEVELOPMENT FOR DESIGN DATA ON STRUCTURAL ALUMINUM ALLOYS IN REPRESENTATIVE AIRCRAFT ENVIRONMENTS.

10 D. I. BROWNHILL,
R. E. DAVIES,
G. E. NORDMARK
R. M. PONCHEL

ALUMINUM COMPANY OF AMERICA
ALCOA LABORATORIES
ALCOA CENTER, PENNSYLVANIA 15069

16 7381 17 07

11 JUL 77

12 196 P.

15 F33615-74-C-5089

9 TECHNICAL REPORT AFML-TR-77-102
Final Report May 74 - Apr 77
1 30

DDC
APR 18 1978
A

Approved for public release; distribution unlimited.

AIR FORCE MATERIALS LABORATORY
AIR FORCE SYSTEMS COMMAND
WRIGHT-PATTERSON AIR FORCE BASE, OHIO 45433

017 460

mt

NOTICE

When Government drawings, specifications, or other data are used for any purpose other than in connection with a definitely related Government procurement operation, the United States Government thereby incurs no responsibility nor any obligation whatsoever; and the fact that the government may have formulated, furnished, or in any way supplied the said drawings, specifications, or other data, is not to be regarded by implication or otherwise as in any manner licensing the holder or any other person or corporation, or conveying any rights or permission to manufacture, use, or sell any patented invention that may in any way be related thereto.

This technical report has been reviewed and is approved for publication.

Allan W. Gunderson

ALLAN W. GUNDERSON
Engineering & Design Data
Materials Integrity Branch

C. L. Harmsworth

C. L. HARMSWORTH
Technical Manager
Engineering and Design Data
Materials Integrity Branch

FOR THE COMMANDER

Thomas D. Cooper

THOMAS D. COOPER
Chief, Materials Integrity Branch
Systems Support Division

Copies of this report should not be returned unless return is required by security considerations, contractual obligations, or notice on a specific document.

UNCLASSIFIED

SECURITY CLASSIFICATION OF THIS PAGE (When Data Entered)

REPORT DOCUMENTATION PAGE		READ INSTRUCTIONS BEFORE COMPLETING FORM	
1. REPORT NUMBER AFML-TR-77-102✓	2. GOVT ACCESSION NO.	3. RECIPIENT'S CATALOG NUMBER	
4. TITLE (and Subtitle) EXPLORATORY DEVELOPMENT FOR DESIGN DATA ON STRUCTURAL ALUMINUM ALLOYS IN REPRESENTATIVE AIRCRAFT ENVIRONMENTS		5. TYPE OF REPORT & PERIOD COVERED FINAL MAY 1, 1974-APRIL 30, 1977	
		6. PERFORMING ORG. REPORT NUMBER	
7. AUTHOR(s) D. J. BROWNHILL, R. E. DAVIES G. E. NORDMARK, B. M. PONCHEL		8. CONTRACT OR GRANT NUMBER(s) F33615-74-C-5089 ^{new}	
9. PERFORMING ORGANIZATION NAME AND ADDRESS ALUMINUM COMPANY OF AMERICA ALCOA LABORATORIES ^v ALCOA CENTER, PA. 15069		10. PROGRAM ELEMENT, PROJECT, TASK AREA & WORK UNIT NUMBERS 73810743	
11. CONTROLLING OFFICE NAME AND ADDRESS UNITED STATES AIR FORCE AIR FORCE SYSTEMS COMMAND MATERIALS LABORATORY 45433 WRIGHT-PATTERSON AIR FORCE BASE, OHIO		12. REPORT DATE JULY 1977	
		13. NUMBER OF PAGES 178	
14. MONITORING AGENCY NAME & ADDRESS (if different from Controlling Office)		15. SECURITY CLASS. (of this report) UNCLASSIFIED	
		15a. DECLASSIFICATION/DOWNGRADING SCHEDULE	
16. DISTRIBUTION STATEMENT (of this Report) Approved for public release; distribution unlimited.			
17. DISTRIBUTION STATEMENT (of the abstract entered in Block 20, if different from Report)			
18. SUPPLEMENTARY NOTES			
19. KEY WORDS (Continue on reverse side if necessary and identify by block number)			
2048	Plate	Bearing	Crack Propagation
7050	Hand Forgings	Modulus of Elasticity	Stress-Corrosion
7475	Tensile	Stress-Strain	Exfoliation
2219	Compressive	Fracture Toughness	
	Shear	Fatigue	
20. ABSTRACT (Continue on reverse side if necessary and identify by block number)			
<p>The mechanical properties, fracture toughness, fatigue, fatigue-crack growth rates in three environments and corrosion characteristics of 10 lots each of 2048-T851, 7050-T7351 and 7475-T7351 plate and 2219-T852 hand forgings have been evaluated. Data for establishing MIL-HDBK-5 values, including modulus of elasticity and stress-strain are presented. The plane-strain stress-intensity factors, K_{Ic}, for the plate products are generally higher, particularly for 7475-T7351.</p>			

DD FORM 1473
1 JAN 73

EDITION OF 1 NOV 68 IS OBSOLETE
S/N 0102-014-6601

UNCLASSIFIED

SECURITY CLASSIFICATION OF THIS PAGE (When Data Entered)

UNCLASSIFIED

SECURITY CLASSIFICATION OF THIS PAGE(When Data Entered)

than those of other commercial alloys of comparable yield strength levels. The 2219-T852 hand forgings exhibit toughness levels higher than those of most other hand forging alloys.

Axial-stress fatigue strengths and rates of fatigue-crack propagation are generally comparable to those of corresponding products of 2XXX and 7XXX alloys. At medium stress intensities, fatigue-crack propagation rates in moist air and sump water are, respectively, 1.5 to 2 times and 2 to 9 times as fast as in dry air. However, at low stress intensities, crack arrest sometimes occurred in the sump water.

All of the products tested display the expected excellent resistance to exfoliation and stress corrosion. The only indications of any susceptibility to intergranular stress-corrosion cracking were obtained for short-transverse specimens from three lots of 2048-T851 plate when tested at an applied stress of 75 per cent of the minimum long-transverse yield strength. The tests of precracked double-cantilever beam specimens showed the same general trends as tests with smooth stress-corrosion specimens.

ACCT. NO.	
RTIS	Write Section <input checked="" type="checkbox"/>
JOC	Buff Section <input type="checkbox"/>
W. C. S.	<input type="checkbox"/>
DIST. CAT'N	
BY	
DISTRIBUTION AVAILABILITY CODES	
DIST.	AVAIL. AND/OR SPECIAL
A	

UNCLASSIFIED

SECURITY CLASSIFICATION OF THIS PAGE(When Data Entered)

PREFACE

This investigation was conducted by Alcoa Laboratories, Aluminum Company of America, Alcoa Center, Pennsylvania under USAF Contract No. F33615-74-C-5089, Project No. 7381, for the Air Force Materials Laboratory, Wright-Patterson Air Force Base, Ohio, with Mr. A. W. Gunderson (AFML/MXA) as project engineer.

This report covers work done from May 1, 1974 through April 30, 1977.

The investigation was made under the supervision of Mr. D. J. Brownhill as project manager with Mr. R. E. Davies as project engineer for the phase covering the mechanical properties including fracture toughness and axial fatigue. The phase covering the fatigue-crack propagation rates was under the supervision of Mr. R. A. Kelsey, with Mr. G. E. Nordmark as project engineer. The phase covering the exfoliation and stress-corrosion characteristics was under the supervision of Mr. D. O. Sprowls, with Mr. B. M. Ponchel as project engineer. Significant advisory and technical assistance were supplied by Messrs. J. G. Kaufman, A. B. Thakker, G. T. Sha and D. J. Lege.

TABLE OF CONTENTS

SECTION	PAGE
I. INTRODUCTION	1
II. MATERIAL	2
III. PROCEDURE	
A. MECHANICAL PROPERTIES.	4
B. FATIGUE-CRACK PROPAGATION TESTS.	8
C. CORROSION CHARACTERISTICS.	11
IV. RESULTS OF TESTS	17
V. DISCUSSION OF RESULTS	
A. MECHANICAL PROPERTIES.	18
B. FATIGUE CRACK-PROPAGATION TESTS.	26
C. CORROSION CHARACTERISTICS.	31
VI. SUMMARY AND CONCLUSIONS	
A. MECHANICAL PROPERTIES.	41
B. FATIGUE-CRACK PROPAGATION.	43
C. CORROSION CHARACTERISTICS.	44
REFERENCES	46

REPRODUCTION PAGE NOT FILLED
BLANK

LIST OF ILLUSTRATIONS

FIGURE		PAGE
1	General Dimensions of Tensile, Compressive and Shear Specimens	50
2	General Dimensions of Bearing Specimens	51
3	Compact Fracture Toughness Specimen	52
4	Fracture Specimen Orientations.	53
5	Setup for Fatigue Precracking of Compact Fracture Toughness Specimens	54
6	Setup for Testing Compact Fracture Toughness Specimens	55
7	Smooth and Notched Axial-Stress Fatigue Specimens .	56
8	Dimensions for Compact Fatigue Crack-Propagation Specimen.	57
9	Fatigue Crack Growth Tests of Compact Specimens . .	58
10	Four Degrees of Severity of Exfoliation Corrosion Per ASTM Standard Method Test G34-72.	59
11	1/8-In. Diameter Tensile Specimen, Various Parts of the Stressing Frame and Final Stressed Assembly for Stress-Corrosion Tests	60
12	Synchronous Loading Device Used to Stress Specimens. Stressed Assembly and One Assembled Finger Tight Ready For Stressing are Shown to the Left	60
13	Configuration of Double Cantilever Beam (DCB) Specimen Used for SCC Tests	61
14	Configuration of Reduced Thickness Double Cantilever Beam (DCB) Specimen Used for SCC Tests.	62
15	Typical Stress-Strain and Tangent-Modulus Curves for 2048-T851 Aluminum Alloy Plate at Room Temperature.	63
16	Typical Stress-Strain and Tangent-Modulus Curves for 7050-T7351 Aluminum Alloy Plate at Room Temperature.	64

LIST OF ILLUSTRATIONS
(Continued)

FIGURE		PAGE
17	Typical Stress-Strain and Tangent-Modulus Curves for 7475-T7351 Aluminum Alloy Plate at Room Temperature	65
18	K_{Ic} Vs Tensile Yield Strength of 7475 Plate, 1.0 to 4.0-In. Thick.	66
19	K_{Ic} Vs Tensile Yield Strength of 2048-T851, 7050-T7351 and 7475-T7351 Plate.	67
20	K_{Ic} Vs Tensile Yield Strength of 2219-T852 Hand Forgings, 2.0 to 7.5-In. Thick.	68
21	Axial-Stress Fatigue Data For Smooth Specimens of 2048-T851 Plate, R = 0.0.	69
22	Axial-Stress Fatigue Data For Notched Specimens of 2048-T851 Plate, R = 0.0.	70
23	Axial-Stress Fatigue Data For Smooth Specimens of 7050-T7351 Plate, R = 0.0	71
24	Axial-Stress Fatigue Data For Notched Specimens of 7050-T7351 Plate, R = 0.0	72
25	Axial-Stress Fatigue Data For Smooth Specimens of 7475-T7351 Plate, R = 0.0	73
26	Axial-Stress Fatigue Data For Notched Specimens of 7475-T7351 Plate, R = 0.0	74
27	Axial-Stress Fatigue Data For Smooth Specimens of 7475-T7351 Plate, R = 0.0 (Current Practice).	75
28	Axial-Stress Fatigue Data For Notched Specimens of 7475-T7351 Plate, R = 0.0 (Current Practice).	76
29	Axial-Stress Fatigue Data For Smooth Specimens of 2219-T852 Hand Forgings, R = 0.0.	77
30	Axial-Stress Fatigue Data For Notched Specimens of 2219-T852 Hand Forgings, R = 0.0.	78
31	Fatigue Crack-Growth Data For 1-In. 2048-T851 Plate, L-T Orientation	79

LIST OF ILLUSTRATIONS
(Continued)

FIGURE		PAGE
32	Fatigue Crack-Growth Data For 1-In. 2048-T851 Plate, T-L Orientation.	80
33	Fatigue Crack-Growth Data For 4-In. 2048-T851 Plate, L-T Orientation.	81
34	Fatigue Crack-Growth Data For 4-In. 2048-T851 Plate, T-L Orientation (dry air).	82
35	Fatigue Crack-Growth Data For 4-In. 2048-T851 Plate, T-L Orientation (sump water)	83
36	Fatigue Crack-Growth Data For 4-In. 2048-T851 Plate, S-L Orientation.	84
37	Fatigue Crack-Growth Data For 2-In. 7050-T7351 Plate, L-T Orientation	85
38	Fatigue Crack-Growth Data For 2-In. 7050-T7351 Plate, T-L Orientation	86
39	Fatigue Crack-Growth Data For 4-In. 7050-T7351 Plate, L-T Orientation	87
40	Fatigue Crack-Growth Data For 4-In. 7050-T7351 Plate, T-L Orientation (dry air)	88
41	Fatigue Crack-Growth Data For 4-In. 7050-T7351 Plate, T-L Orientation (sump water).	89
42	Fatigue Crack-Growth Data For 4-In. 7050-T7351 Plate, S-L Orientation	90
43	Fatigue Crack-Growth Data For 1-In. 7475-T7351 Plate, L-T Orientation	91
44	Fatigue Crack-Growth Data For 1-In. 7475-T7351 Plate, T-L Orientation	92
45	Fatigue Crack-Growth Data For 4-In. 7475-T7351 Plate, L-T Orientation	93
46	Fatigue Crack-Growth Data For 4-In. 7475-T7351 Plate, T-L Orientation (dry air)	94

LIST OF ILLUSTRATIONS
(Continued)

FIGURE		PAGE
47	Fatigue Crack-Growth Data For 4-In. 7475-T7351 Plate, T-L Orientation (sump water)	95
48	Fatigue Crack-Growth Data For 4-In. 7475-T7351 Plate, S-L Orientation	96
49	Fatigue Crack-Growth Data For a 0.75-In. 7475-T7351 Plate, (Current Practice), T-L Orientation	97
50	Fatigue Crack-Growth Data For 3.5-In. 7475-T7351 Plate, (Current Practice), T-L Orientation (dry air).	98
51	Fatigue Crack-Growth Data For 3.5-In. 7475-T7351 Plate. (Current Practice), T-L Orientation (sump water)	99
52	Fatigue Crack-Growth Data For 3.5-In. 7475-T7351 Plate, (Current Practice), S-L Orientation (dry air).	100
53	Fatigue Crack-Growth Data For a 2 x 8-In. 2219-T852 Hand Forging, L-T Orientation.	101
54	Fatigue Crack-Growth Data For a 2 x 8-In. 2219-T852 Hand Forging, T-L Orientation.	102
55	Fatigue Crack-Growth Data For a 5.5 x 22-In. 2219-T852 Hand Forging, L-T Orientation.	103
56	Fatigue Crack-Growth Data For a 5.5 x 22-In. 2219-T852 Hand Forging, T-L Orientation (dry air).	104
57	Fatigue Crack-Growth Data For a 5.5 x 22-In. 2219-T852 Hand Forging, T-L Orientation.	105
58	Fatigue Crack-Growth Data For a 5.5 x 22-In. 2219-T852 Hand Forging, S-L Orientation.	106
59	Comparison of Fatigue-Crack Growth Rates for Thick Plate, T-L Orientation	107
60	Sump Water Induced Arrest of Low Growth Rate Fatigue Crack in 7475-T7351 Plate (S.E.M.)	108

LIST OF ILLUSTRATIONS
(Continued)

FIGURE		PAGE
61	Illustrates Type of Attack in Center Plane Test Panel From a 2.5-In. Thick 2219-T852 Alloy Hand Forging Exposed to EXCO Test.	109
62	View of Figure 61 At a Higher Magnification	109
63	Environmental Crack Growth of Short-Transverse 2219-T852 Alloy DCB Specimens Removed From a 2.5-In. Thick Hand Forging.	110
64	Environmental Crack Growth of Short-Transverse 2219-T852 Alloy DCB Specimens Removed From a 4.5-In. Thick Hand Forging.	111
65	Environmental Crack Growth of Short-Transverse 2219-T852 Alloy DCB Specimens Removed From a 7.5-In. Thick Hand Forging.	112
66	Environmental Crack Growth of Short-Transverse 2048-T351 Alloy DCB Specimens Removed From a 2-In. Thick Plate	113
67	Environmental Crack Growth of Short-Transverse 2048-T851 Alloy DCB Specimens Removed From a 4-In. Thick Plate	114
68	Environmental Crack Growth of Short-Transverse 7050-T7351 Alloy DCB Specimens Removed From a 2-In. Thick Plate	115
69	Environmental Crack Growth of Short-Transverse 7050-T7351 Alloy DCB Specimens Removed From a 4-In. Thick Plate	116
70	Environmental Crack Growth of Short-Transverse 7050-T7351 Alloy DCB Specimens Removed From a 6-In. Thick Plate	117
71	Environmental Crack Growth of Short-Transverse 7050-T7351 Alloy DCB Specimens Removed From a 6-In. Thick Plate	118
72	Environmental Crack Growth of Short-Transverse 7475-T7351 Alloy DCB Specimens Removed From a 2-In. Thick Plate	119

LIST OF ILLUSTRATIONS
(Continued)

FIGURE		PAGE
73	Environmental Crack Growth of Short-Transverse 7475-T7351 Alloy DCB Specimens Removed From a 4-In. Thick Plate.	120
74	K-Rate Comparison of the Materials	121
75	Environmental Crack Growth of Short-Transverse 2048-T851 Alloy DCB Specimens Removed From a 4-In. Thick Plate (Specimen Thickness: 0.25-In.)	122
76	Environmental Crack Growth of Short-Transverse 2048-T851 Alloy DCB Specimens Removed From a 4-In. Thick Plate (Specimen Thickness: 0.50-In.)	123
77	Environmental Crack Growth of Short-Transverse 2048-T851 Alloy DCB Specimens Removed From a 4-In. Thick Plate.	124
78	Environmental Crack Growth of Short-Transverse 7050-T7351 Alloy DCB Specimens Removed From a 4-In. Thick Plate (Specimen Thickness: 0.25-In.)	125
79	Environmental Crack Growth of Short-Transverse 7050-T7351 Alloy DCB Specimens Removed From a 4-In. Thick Plate (Specimen Thickness: 0.50-In.)	126
80	Environmental Crack Growth of Short-Transverse 7050-T7351 Alloy DCB Specimens Removed From a 4-In. Thick Plate.	127
81	Environmental Crack Growth of Short-Transverse 7475-T7351 Alloy DCB Specimens Removed From a 4-In. Thick Plate (Specimen Thickness: 0.25-In.)	128
82	Environmental Crack Growth of Short-Transverse 7475-T7351 Alloy DCB Specimens Removed From a 4-In. Thick Plate (Specimen Thickness: 0.50-In.)	129
83	Environmental Crack Growth of Short-Transverse 7475-T7351 Alloy DCB Specimens Removed From a 4-In. Thick Plate (Specimen Thickness: 0.80-In.)	130

LIST OF ILLUSTRATIONS
(Concluded)

FIGURE		PAGE
84	Environmental Crack Growth of Short-Transverse 7475-T7351 Alloy DCB Specimens Removed From a 4-In. Thick Plate.	131
85	Environmental Crack Growth of Short-Transverse 7475-T7351 Alloy DCB Specimens Removed From a 2.25-In. Thick Plate	132
86	Environmental Crack Growth of Short-Transverse 7475-T7351 Alloy DCB Specimens Removed From a 3.5-In. Thick Plate.	133

LIST OF TABLES

TABLE		PAGE
1	Chemical Compositions of 2048-T851 Plate	134
2	Chemical Compositions of 7050-T7351 Plate	135
3	Chemical Compositions of 7475-T7351 Plate	136
4	Chemical Compositions of 2219-T852 Hand Forgings. .	137
5	Mechanical Properties of 2048-T851 Plate.	138
6	Mechanical Properties of 7050-T7351 Plate	139
7	Mechanical Properties of 7475-T7351 Plate	140
8	Mechanical Properties of 7475-T7351 Plate (Current Practice)	141
9	Mechanical Properties of 2219-T852 Hand Forgings. .	142
10	Ratios Among the Tensile, Compressive, Shear and Bearing Properties of 2048-T851 Plate	143
11	Ratios Among the Tensile, Compressive, Shear and Bearing Properties of 7050-T7351 Plate.	144
12	Ratios Among the Tensile, Compressive, Shear and Bearing Properties of 7475-T7351 Plate.	145
13	Ratios Among the Tensile, Compressive, Shear and Bearing Properties of 7475-T7351 Plate (Current Practice)	146
14	Ratios Among the Tensile, Compressive, Shear and Bearing Properties of 2219-T852 Hand Forgings . . .	147
15	Results of Tensile and Compressive Modulus of Elasticity Tests of 2048-T851, 7050-T7351 and 7475-T7351 Plate and 2219-T852 Hand Forgings. . . .	148
16	Typical Stress-Strain Data for 2048-T851 Plate. . .	149
17	Typical Stress-Strain Data for 7050-T7351 Plate . .	150
18	Typical Stress-Strain Data for 7475-T7351 Plate . .	151

LIST OF TABLES
(Continued)

TABLE		PAGE
19	Data for Establishing Typical Stress-Strain Curves for 2219-T852 Hand Forgings	152
20	Data for Typical Compressive Tangent-Modulus Curves for 2048-T851, 7050-T7351 and 7475-T7351 Plate. . .	153
21	Results of Fracture-Toughness Tests of 2048-T851 Plate	154
22	Results of Fracture-Toughness Tests of 7050-T7351 Plate	155
23	Results of Fracture-Toughness Tests of 7475-T7351 Plate	156
24	Results of Fracture-Toughness Tests of 7475 Plate (Current Practice).	157
25	Results of Fracture-Toughness Tests of 2219-T852 Hand Forgings	158
26	Rates of Fatigue-Crack Propagation.	159
27	Results of Tests to Evaluate the Resistance to Exfoliation of Samples of 2219-T852 Hand Forgings .	160
28	Results of Tests to Evaluate the Resistance to Exfoliation of Samples of 7050-T7351 Alloy Plate. .	161
29	Results of Tests to Evaluate the Resistance to Exfoliation of Samples of 2048-T851 Alloy Plate . .	162
30	Results of Tests to Evaluate the Resistance to Exfoliation of Samples of 7475-T7351 Alloy Plate. .	163
31	Results of Stress-Corrosion Testing of 0.125-In. Diam. Tension Specimens of 2219-T852 Alloy Hand Forgings By Alternate Immersion in a 3.5% Sodium Chloride Solution for 84 Days (ASTM G44-75)	164
32	Results of Stress-Corrosion Testing of 0.125-In. Diam. Tension Specimens of 7050-T7351 Alloy Plate By Alternate Immersion in a 3.5% Sodium Chloride Solution for 84 Days (ASTM G44-75).	165

LIST OF TABLES
(Continued)

TABLE		PAGE
33	Results of Stress-Corrosion Testing of 0.125-In. Diam. Tension Specimens of 2048-T851 Alloy Plate By Alternate Immersion in a 3.5% Sodium Chloride Solution for 84 Days (ASTM G44-75).	166
34	Results of Stress-Corrosion Testing of 0.125-In. Diameter Tension Specimens of 7475-T7351 Alloy Plate By Alternate Immersion in a 3.5% Sodium Chloride Solution for 84 Days (ASTM G44-75).	167
35	Results of Stress-Corrosion Tests of 0.125-In. Diameter Short-Transverse Tension Specimens of 2219-T852 Alloy Hand Forgings In Outdoor Atmospheres.	168
36	Results of Stress-Corrosion Tests of 0.125-In. Diameter Short-Transverse Tension Specimens of 7050-T7351 Alloy Plates In Outdoor Atmospheres. . . .	169
37	Results of Stress-Corrosion Tests of 0.125-In. Diameter Short-Transverse Tension Specimens of 2048-T851 Alloy Plates In Outdoor Atmospheres	170
38	Results of Stress-Corrosion Tests of 0.125-In. Diameter Short-Transverse Tension Specimens of 7475-T7351 Alloy Plates In Outdoor Atmospheres. . . .	171
39	Results of Initial Stress Intensity, K_{Ic} , Loads of Double Cantilever Beam Specimens.	172
40	Average Crack Growth Velocities for Double Cantilever Beam Specimens Exposed to 3.5% NaCl Solution Dropwise for 30 Days	173
41	Average Crack Growth Velocities of Reduced Thickness DCB Specimens Exposed to 3.5% NaCl Solution Dropwise for 30 Days	174
42	Results of Stress-Corrosion Testing of 0.125-In. Diameter Short-Transverse Tension Specimens of 7475-T7351 Alloy Plate By Alternate Immersion In a 3.5% Sodium Chloride Solution for 84 Days (ASTM G44-75)	175

LIST OF TABLES
(Concluded)

TABLE		PAGE
43	Results of Stress Corrosion Tests of 0.125-In. Diameter Short-Transverse Tension Specimens of 7475-T7351 Alloy Plates In Outdoor Atmospheres. . . .	176
44	Results of Initial Stress Intensity, K_{Ic} , Loads of Double Cantilever Beam Specimens.	177
45	Average Crack Velocities for Double Cantilever Beam Specimens From 7475-T7351 Alloy Plates and Exposed to 3.5% NaCl Solution Dropwise.	178

SUMMARY

The mechanical properties, fracture toughness, fatigue, fatigue-crack growth rates in three environments and corrosion characteristics of 10 lots each of 2048-T851, 7050-T7351 and 7475-T7351 plate and 2219-T852 hand forgings have been evaluated.

Data for establishing MIL-HDBK-5 values, including modulus of elasticity and stress-strain are presented.

The plane-strain stress-intensity factors, K_{Ic} , for the plate products are generally higher, particularly for 7475-T7351, than those of other commercial alloys of comparable yield strength levels. The 2219-T852 hand forgings exhibit toughness levels higher than those of most other hand forging alloys.

Axial-stress fatigue strengths are in the same general range as those of corresponding products of 2XXX and 7XXX alloys.

In dry and moist air, rates of fatigue-crack propagation are generally similar for the hand forging and the three plate alloys and comparable to rates reported for other high-strength aluminum alloys. At medium stress intensities, fatigue-crack propagation rates are 1.5 to 2 times as fast in moist air as in dry air and 2 to 9 times as fast in sump water as in dry air; rates in sump water were slower for the 2XXX products than those for the 7XXX plate. However, at low stress intensities, propagation in the 7XXX plate and the 2219 hand forging slowed or arrested in the sump water, apparently due to a buildup of corrosion product on the fracture surface.

All of the products tested display the expected excellent resistance to exfoliation and stress corrosion. The only indications of any susceptibility to intergranular stress-corrosion cracking were obtained for short-transverse specimens from three lots of 2048-T851 plate when tested at an applied stress of 75 per cent of the minimum long-transverse yield strength. All of the lots of 2048-T851 plate display the expected excellent resistance to stress corrosion in the critical short-transverse direction at a test stress of 50 per cent of the minimum long-transverse yield strength. The tests of precracked double-cantilever beam specimens showed the same general trends as tests with smooth stress-corrosion specimens.

SECTION I
INTRODUCTION

The high performance required of aerospace structures demands that adequate consideration be given to the influence of service environments, and therefore the development of design related data must take such influence into account. The data in this investigation were generated to support the AFML service failure analysis efforts and to serve as a basis for evaluating the alloys for use in new Air Force systems. A considerable amount of this type of data has been developed previously for other alloys, tempers and products intended for such critical service[1-11].

The purpose of this investigation was to evaluate environmental fatigue crack-growth rates and corrosion characteristics as well as data for establishing design mechanical properties for four alloys which might be subjected to critical environmental service, i.e., 2048-T851, 7050-T7351 and 7475-T7351 plate and 2219-T852 hand forgings. Specifically, sufficient data have been developed for these products to establish statistically meaningful design mechanical properties for use in MIL-HDBK-5[12] and to provide a level of confidence in the data on fracture toughness, fatigue strength, fatigue-crack propagation rates, exfoliation and stress-corrosion resistance.

SECTION II

MATERIAL

The products tested in this investigation included ten lots each of the following:

<u>Alloy and Temper</u>	<u>Product</u>	<u>Thickness Range, in.</u>	<u>Producer</u>
2048-T851	Plate	0.5 to 4.0	Reynolds
7050-T7351	Plate	2.0 to 6.0	Alcoa
7475-T7351	Plate	0.5 to 4.0	Alcoa
2219-T852	Hand Forgings	2.0 to 7.5	Alcoa

These products were produced by commercial practices in use at the time of fabrication. The chemical compositions of each sample, determined at Alcoa Laboratories and shown in Tables 1 through 4, are within the specified limits shown in the same tables.

The tensile properties of all samples met their respective tentative minimum properties, Tables 5 through 9. Minimum properties have been established for the 2048-T851 plate in thicknesses 2.001 to 3.000 in. only. The minimum values can be expected to be about 5 to 6 ksi below the expected typical properties shown in Table 5.

Tentative minimum K_{Ic} values have been established for 7475-T7351 plate. The fracture toughness data obtained for the samples tested in this investigation developed K_{Ic} , or K_Q , values above the tentative minimum values. However, it was realized, after comparison with data from tests of lots produced prior to the contract, that the levels of fracture toughness developed

were not representative of current production. The relatively low values obtained for the lots produced for the contract were attributed to the fabrication practices utilized at that time. These practices were subsequently revised to eliminate the possibility of conditions which lead to toughness levels lower than normally achievable in 7475-T7351 plate. Because the ten samples of 7475-T7351 plate were not considered to be representative of the capabilities of current production material, ten additional lots were fabricated and tested for toughness to demonstrate the high toughness of this product. A few of these samples were also tested for mechanical properties, fatigue, fatigue-crack propagation and corrosion characteristics.

SECTION III

PROCEDURE

A. Mechanical Properties

A.1. Tensile, Compressive, Shear and Bearing

The tensile, compressive, shear and bearing tests were made using the smallest suitable range of an Amsler 20,000-lb (type 105XBDA58), an Olsen Electromatic 30,000-lb and an Olsen Super-L 20,000-lb or a Southwark-Tate-Emery 50,000-lb capacity Universal Testing Machine. The machines were calibrated prior to and during the investigation. The accuracy of these machines was within that required by ASTM Method E4[13].

The test specimens and procedures used were, where appropriate, the same as those used in previous investigations of sheet, plate, extrusions and forgings[1-3, 6, 9-11, 14]. Single specimens were tested except where initial results indicated check tests were necessary. Where check tests were made for tensile properties, duplicate tests were made. Specimens were taken in the test directions and locations specified in ASTM B557[15]. Specimens (L and LT) from 0.5 to 1.0-in. thick plate were taken from T/2 (thickness/2) and for plate 1.75-in. thick and greater from T/4; short-transverse specimens were taken from T/2. All specimens from the 2219-T852 hand forgings were from T/2.

Tensile tests were made in accordance with ASTM E8[16] with 1/2-in. diameter tapered-seat specimens, except where it was necessary to use subsize round specimens (Fig. 1). The yield

strengths were determined from autographically recorded load-strain diagrams.

Compressive tests were made in accordance with ASTM E9[17] using a subpress (Fig. 3 of ASTM E9). All specimens were the cylindrical type shown in Fig. 1. The yield strengths were determined from autographically recorded load-strain diagrams.

Shear tests were made using cylindrical specimens (Fig. 1); these specimens were tested in an Amsler double-shear tool in which a 1-in. length is sheared from the center of a 3-in. long specimen, the end thirds being supported throughout their length. In tests of longitudinal and long-transverse specimens, the loads were applied in the direction normal to the major surface of the product; in tests of short-transverse specimens, the loads were applied in the longitudinal direction[18].

Bearing tests were made in accordance with ASTM E238[19] using longitudinal and long-transverse specimens of the type shown in Fig. 2. Specimens were 0.094-in. thick. The bearing ultimate and yield strengths were determined at edge distance of 1.5 and 2.0 times the pin diameter. The bearing yield strength was obtained by determining the load at a permanent deformation of 2 per cent of the pin diameter as indicated on an autographic load-deformation diagram. Bearing specimens were taken flatwise from plate and edgewise from the hand forging. The specimens and test fixtures were cleaned ultrasonically as prescribed in ASTM E238.

Tensile and compressive stress-strain tests, including modulus of elasticity determinations, were made of longitudinal, long-transverse and, where possible, short-transverse specimens from four or five samples of each alloy and product. The tests were, in general, conducted in accordance with ASTM E111[20]. The tensile and compressive specimens were of the type shown in Fig. 1.

For the stress-strain tests, loads were measured with Revere Super Precision-type load cells having an accuracy, traceable to the National Bureau of Standards, of 0.1 per cent of rated output. Strains were measured with Micro-Measurements Types CFA-13-062UW-350 strain gages. These gages have a gage factor accuracy of 0.5 per cent and a resistance accuracy of 0.3 per cent. Overall accuracy of load measurement did not exceed 0.5 per cent of reading or 0.25 per cent of full scale, whichever was larger. Strain measurement accuracy was 0.7 per cent of reading or 0.5 per cent of full scale, whichever was larger; the accuracy of the gages was well within the requirements established for Class B1 extensometers in ASTM E83[21].

The specimens were tested to the 0.2 per cent offset yield strength of the material. The stress and strain data were recorded in computer storage for use in establishing typical stress-strain and compressive tangent-modulus curves. The modulus of elasticity values were determined from Tuckerman analysis plots of these data as described in ASTM E111.

A.2. Fracture Toughness

The plane-strain stress-intensity factor, K_{Ic} , was determined with fatigue-cracked compact specimens of the type shown in Fig. 3. Triplicate specimens were tested for the L-T, T-L and S-L orientations, Fig. 4. The dimensions and notches of the specimens and the fatigue-cracking and testing procedures were essentially in accordance with ASTM E399[22]. The specimens were fatigue cracked by axial loading ($R = +0.1$) in Krouse fatigue machines. The test setups for fatigue precracking and fracture toughness testing are shown in Figs. 5 and 6, respectively. Plots of load versus crack-opening displacement were recorded using a Mosley X-Y recorder. Candidate values of critical plane-strain stress-intensity factor, K_Q , were calculated using the load at 5 per cent secant offset which is equivalent to about 2 per cent of crack extension. If all the validity criteria specified in ASTM Method E399 were met, the candidate value was designated as K_{Ic} . Values of K_Q which failed to meet certain validity criteria by no more than 10 per cent were considered to be meaningful values, in that they were indicative of the fracture toughness of the material.

A.3. Axial-Stress Fatigue (Ambient Air)

Axial-stress smooth and notched fatigue specimens tested were of the type shown in Fig. 7. Longitudinal and long-transverse specimens were tested from each product and short-transverse specimens were tested from products equal to or greater than 3.5-in. in thickness. The specimens were taken from the same

locations as the tensile specimens. Tests were made at a stress ratio of $R^* = 0.0$. Sufficient tests were made of two lots of each alloy and product to determine fatigue strengths between about 10^3 and 10^7 cycles. Generally, three to five tests were made of the remaining lots tested. All tests were made in Krouse fatigue machines operating at 13.3, 25.0 or 28.8 Hz.

B. Fatigue-Crack Propagation Tests

Fatigue-crack propagation rates were determined for two sizes of hand forging and each plate alloy. The following additional variables were included for one or more of the four alloys: environment, frequency, stress ratio, specimen orientation, specimen size, and specimen location. One T-L specimen was taken from the surface of a 2219-T852 forging; all other specimens had their test sections taken from the middle third of the material. Specimens were taken in the L-T, T-L and, where possible, the S-L orientations. Typical dimensions for the compact specimens are shown in Fig. 8; because of product or material limitations, the plan dimensions of a few S-L specimens were proportionally smaller than shown. The 1-in. thick specimens were used to obtain data at medium to high-stress intensities whereas the 1/4-in. thick specimens were used for obtaining data at low-stress intensities approaching threshold.

* R , Stress Ratio = $\frac{\text{Minimum Stress}}{\text{Maximum Stress}}$

The cracks in some L-T specimens deviated considerably from the plane of the notch. Data for such specimens are of questionable value since neither length measurements nor the stress-intensity solutions are correct; a proposed specification[23] would classify data for crack fronts deviating by more than 5° as invalid. To reduce the likelihood of angled propagation, many of the L-T specimens had their widths (W) reduced to provide an H/W ratio = 0.6 instead of 0.485. Previous tests [10] have demonstrated that equivalent results are obtained for the two geometries of specimens.

Tests were made in load control using closed loop, servo-controlled, test systems in three environments: dry air, moist air and sump water. Humidity was controlled within test chambers such as shown in Fig. 9. Dry air (relative humidity <10 per cent) was obtained using dessicants; moist air (relative humidity 96 to 99 per cent) was obtained by forcing moist air through the chamber. Synthetic sump water was contained in small troughs bonded to the test section. The sump-tank water, composed of chlorides of various metals, was prepared as reported in Ref. 24.

Its composition is shown below:

	Salt		Metal Ion, ppm	Chloride ppm
	Ppm	Weight, per cent		
CaCl ₂	50	0.005	18	32
CdCl ₂	1000	0.100	490	310
MgCl ₂	50	0.005	6	18
NaCl	100	0.010	20	30
ZnCl ₂	10	0.001	4.7	5.2
CrCl ₃ .6H ₂ O	1	0.001	0.2	0.3
CuCl ₂ .2H ₂ O	1	0.001	0.4	0.4
FeCl ₃	5	0.005	1.7	3.3
MnCl ₂ .4H ₂ O	5	0.005	1.4	1.8
NiCl ₂ .6H ₂ O	1	0.001	0.2	0.3
PbCl ₂	1	0.001	0.7	0.3
Total	1224	0.135	543.3	401.6

To study the effect of test frequency, tests of many specimens were alternated between 20 and 2 Hz. For the large number of loadings required for the low-growth rate tests, data was obtained at 30 to 40 Hz. Some tests were slowed in late stages to maintain load stability or for running the test overnight.

The normal stress ratio for these tests was $1/3$. To obtain some data on the effect of stress ratio, the minimum load for some low-growth rate specimens was increased when the test reached medium stress intensities to produce a stress ratio of $2/3$.

Fatigue precracks for the high-growth rate tests were started at $R = 0.1$. For the low-growth rate tests, it was necessary to approach the test loads by successive load reductions of 10 to 15 per cent. The final portion of precracking was accomplished at test conditions. Visual-crack length measurements were made using low power magnification (15X) and a series of reference grid lines (0.02 in.) photographically printed on both sides of the specimen (Fig. 9). To increase the range of data obtained, the test loads were increased periodically during the test.

The rate of fatigue-crack growth, $\Delta a/\Delta N$, was determined from crack length (a) versus number of cycles (N) data evaluating incrementally the derivative of a versus N . These growth rates were plotted against the range in stress intensity evaluated at the average crack length over which the Δa increment was taken.

The expressions for stress intensity were:

$$\Delta K = \frac{\Delta P \sqrt{a}}{BW} Y,$$

Where: P = load, thousand pounds,

$$Y, (H/W=0.485) = 30.96 - 195.8 \left(\frac{a}{W}\right) + 730.6 \left(\frac{a}{W}\right)^2 - 1186.3 \left(\frac{a}{W}\right)^3 \\ + 754.6 \left(\frac{a}{W}\right)^4, \quad [\text{Ref. 25}]$$

$$Y, (H/W=0.6) = 29.6 - 185.5 \left(\frac{a}{W}\right) + 655.7 \left(\frac{a}{W}\right)^2 - 1017.0 \left(\frac{a}{W}\right)^3 \\ + 638.9 \left(\frac{a}{W}\right)^4, \quad [\text{Ref. 26}]$$

a, B, W, and H (see Fig. 8).

C. Corrosion Characteristics

C.1. Resistance to Exfoliation

The resistance to exfoliation of the various products was evaluated by means of 2 x 4 in. panels machined to the T/10 and the T/2 planes (10 or 50 per cent of the section thickness machined from one of the fabricated surfaces) and exposed to the EXCO test per ASTM G34-72[27]. The EXCO test involves total immersion in a 4N NaCl + 0.5 N KNO₃ 0.1N HNO₃ solution. In addition, 3 x 5 in. panels from selected lots of each product were machined to the T/10 and the T/2 plane and exposed to the acidified salt-spray test (MASTMAASIS) as specified in MIL-A-8978, 8979, and 8980[28]. Specimens exposed to the two accelerated tests were rated visually using the photographic standards

contained in ASTM G34-72[27], Fig. 10. The lots of each product selected for testing in the acidified salt-spray test were also evaluated by the exposure of 3 x 9 in. panels from the T/10 and T/2 plane to the seacoast atmosphere at Point Judith, Rhode Island. The Alcoa exposure station at Point Judith is located about 300 feet from the water's edge with the accompanying elements of considerable salt mist, persistent fog, and prevailing off-shore winds. Corrosive conditions at this location are severe and are comparable to those at the ASTM seacoast station at La Jolla, California.

C.2. Resistance to Stress-Corrosion
Cracking (SCC) - Smooth Specimens

The resistance to stress-corrosion cracking of aluminum alloy wrought products is most critical in the short-transverse direction; consequently the majority of the tests were made on specimens oriented in that direction. Four lots of each product were, however, selected for testing of longitudinal and long-transverse specimens in the accelerated stress-corrosion test at an applied stress of 75 per cent of the specified or tentative minimum long-transverse yield strength for the specific product and thickness. Short-transverse specimens from all lots of each product that were at least 2.0-in. thick were exposed to the accelerated stress-corrosion test at applied stresses of both 75 per cent and 50 per cent of the minimum long-transverse yield strength. The short-transverse specimen exposure program was

duplicated for a seacoast and an industrial atmospheric exposure. Unstressed control specimens were included for each combination of product lot, test direction, and test environment. Unstressed specimens were exposed in duplicate and stressed specimens were exposed in triplicate.

The test specimens for all three test directions were 0.125-in. diameter threaded-end tension specimens meeting the requirements of ASTM E8. The short-transverse specimens were centered on the midplane of the products and the longitudinal and long-transverse specimens were taken on or immediately adjacent to the midplane. The stressed specimens were axially loaded in tension in a constant strain-type fixture, Fig. 11, using the synchronous loading device shown in Fig. 12.

The accelerated stress-corrosion test method was the 3.5 per cent sodium chloride by alternate immersion conforming to ASTM G44-75[29], and Federal Test Standard 151b, Method 823[30]. The alternate-immersion cycle consists of 10 minutes of total immersion followed by aeration and drying above the solution for the remaining 50 minutes of each hour, 24 hours per day. The exposure period for the accelerated test was 12 weeks with daily inspection of the test specimens for failures. All fractured specimens were subjected to visual and microscopic examination to determine the nature of the failure. Specimens that did not fail during the 12 week test were tension tested to determine the loss in strength as compared to the unstressed control specimens.

The atmospheric stress-corrosion testing in a seacoast environment is being conducted at Point Judith, Rhode Island. The conditions at this exposure station were previously discussed for the exfoliation testing being conducted at that location. The stress-corrosion tests in an inland industrial atmosphere are being conducted at the Alcoa Technical Center test station near New Kensington, Pennsylvania. Data obtained at New Kensington may be used to indicate conservatively the resistance of aluminum alloys to the atmosphere in most inland industrial areas and to atmospheres in substantially all non-industrial, non-marine areas.

C.3. Resistance to SCC - Precracked Specimens

Stress-corrosion cracking tests of precracked specimens were conducted on selected lots of the various products with double bolt-loaded double cantilever beam (DCB) specimens of the type shown in Fig. 13. Laboratory tests to evaluate the effect of DCB specimen geometry indicated that the optimum a/h ratio (crack length/half beam height) would be obtained by testing a specimen having a 1.0-in. beam height and a chevron-type notch 1.0-in. in depth. Specimens of this geometry were machined using short-transverse sections of S-L orientation removed from the center plane of the selected lots of the various products. The DCB specimens were precracked in tension to an initial crack length of approximately 0.1 in. Duplicate specimens were exposed to 3.5 per cent sodium chloride solution, to the inland industrial

atmosphere at the Alcoa Technical Center, and to the seacoast atmosphere at Point Judith, Rhode Island.

The DCB specimens that were to be exposed to 3.5 per cent sodium chloride solution were precracked after a few drops of 3.5 per cent sodium chloride solution were placed in the notch. During the 30 day test the specimens were placed vertically and kept in a laboratory environment having a controlled temperature of $27^{\circ}\text{C} \pm 1^{\circ}\text{C}$ and a controlled relative humidity of 45 ± 6 per cent. A few drops of the 3.5 per cent sodium chloride solution (reagent grade NaCl and deionized water) were added to the crack three times during each normal working day and once on Saturdays, Sundays, and holidays. Crack lengths at the half and quarter planes were measured three or four times each week using an ultrasonic detection device developed at the Alcoa Technical Center.

The average of the three crack-length measurements was used to calculate the pertinent stress-intensity values as a function of crack-opening displacement and crack length using the formula developed by Hyatt[31]. At the end of the 30 day exposure the specimens were unloaded and broken open to permit examination of the crack fronts.

Reduced specimen thickness DCB specimens, Fig. 14, from the center plane of 4.0-in. thick 2048-T851, 7050-T7351, and 7475-T7351 alloy plate were also tested by exposure of duplicate specimens

to the 3.5 per cent sodium chloride solution for 30 days, although previous tests of 2024-T351 and 7075-T651[32] have suggested that crack-growth rates and threshold levels may be independent of the stress state. A plane-strain stress state was expected for the 1.0-in. thick specimen used for the bulk of the testing of precracked specimens. Reduced specimen thickness of 0.25 and 0.5 inches expected to result in a mixed mode stress state were used for the DCB specimens from the 4.0-in. thick plate of each alloy. A reduced specimen thickness of 0.8 in. was also tested for the 4.0-in. thick 7475 alloy contract plate.

SECTION IV
RESULTS OF TESTS

The results of the tensile, compressive, shear and bearing tests, the ratios among these test results, and the modulus of elasticity data are shown in Tables 5 through 15. Data for developing stress-strain and tangent-modulus curves are shown in Tables 16 through 20; the curves are shown in Figs. 15, 16, and 17 for the plate alloys.

The results of fracture toughness test are shown in Tables 21 through 25 and plotted in Figs. 18, 19, and 20.

The axial-stress fatigue data are plotted in Figs. 21 through 30.

The results of the fatigue crack-growth tests are presented in the form of $\Delta a/\Delta N$ versus ΔK plots in Figs. 31 through 58; the results are grouped to demonstrate environmental effects. Comparison of average crack-growth curves for T-L specimens from thick plate is shown in Fig. 59. Table 26 lists average rates of propagation along with rates determined for other tempers or alloys.

The results of the exfoliation tests are given in Tables 27 through 30. The results of accelerated stress-corrosion tests of smooth specimens are presented Tables 31 through 34. Atmospheric stress-corrosion results are contained in Tables 35 through 38. The results for precracked specimens are shown in Tables 39 through 41 and Figs. 63 through 86.

SECTION V

DISCUSSION OF RESULTS

A. Mechanical Properties

A.1. Tensile, Compressive, Shear and Bearing

The tensile properties of the four alloys tested in this investigation met their respective tentative minimum values where established (Tables 5 through 9). The ten lots of 7475-T7351 plate produced by current practices, exhibited tensile properties (Table 8) a little higher than those tested under the contract (Table 7).

The long-transverse tensile ultimate and yield strengths were used for computing ratios among the tensile, compressive, shear and bearing properties (Tables 10 through 14). This procedure was in accordance with recent revisions in Chapter 9 of MIL-HDBK-5, Guidelines for Presentation of Data[12]. Under terms of the modified contract (F33615-74-C-5089), the statistical analyses of the ratios for determining reduced ratios were not included in the investigation. The reduced ratios will be computed prior to proposing design allowables for each alloy for inclusion in MIL-HDBK-5.

Although present, but not recognized in previous Air Force Contract data for 2XXX and 7XXX aluminum alloy plate[9, 14], the shear and bearing ratios for plate up through 1.500 in. thick usually differ from those greater than 1.500 in. thick. This difference can be attributed to the specification test location in the plate thickness, T/2 as opposed to T/4. The

ratios for 7475-T7351 contract plate (Table 12) and those for the current production plate (Table 13), when combined, indicate the aforementioned differences for the two thickness ranges; these shear and bearing ratios should be analyzed separately. These differences are also indicated for the 7050-T7351 plate, but are not as evident for the 2048-T851 plate data.

The results of the modulus of elasticity tests obtained from the stress-strain tests are shown in Table 15. Average modulus values for use in MIL-HDBK-5 are as follows:

Alloy and Temper	Product	Modulus, 10^3 ksi	
		Tension, (E)	Compression (E_c)
2048-T851	Plate	10.4	10.7
7050-T7351	Plate	10.3	10.6
7475-T7351	Plate	10.3	10.6
2219-T852	Hand Forgings	10.2	10.4

The modulus values for plate are in the same range as those for other 2XXX and 7XXX plate alloys. The values for 2219-T852 hand forging average about 3 per cent lower than those for 2014-T652 and 2024-T852 hand forgings[6]. The modulus values for the two lots of current production 7475-T7351 plate (Table 8) are in agreement with those of the 7475-T7351 contract plate.

The longitudinal and short-transverse modulus values for plate average 1 per cent and 1 to 2 per cent, respectively, lower than the corresponding long-transverse values. The 2219-T852 hand forging modulus values are the same for the longitudinal and long-transverse directions; short-transverse values average 2 per cent lower than those for the long-transverse direction.

The typical tensile and compressive stress-strain curves and compressive tangent-modulus curves are plotted in Fig. 15, 16, and 17 for 2048-T851, 7050-T7351 and 7475-T7351 plate, respectively. Curves for 2219-T852 hand forgings could not be developed due to insufficient production data to establish typical tensile properties. The typical stress-strain data are shown in Tables 16 through 18 for the plate and Table 19 for the 2219-T852 hand forgings. The typical stresses are also shown in the tables for each strain departure as a percentage of the typical yield strength in the event that the typical yield strengths are revised for the plate, or developed for the 2219-T852 hand forgings; these percentages can then be applied to the new typical yield strength values to establish stress-strain curves.

The data for the typical compressive tangent-modulus curves for the plate are shown in Table 20. These data are applicable to the typical yield strengths shown for the stress-strain curves. Revisions in the typical yield strengths will require recomputing of the tangent-modulus data.

A.2. Fracture Toughness

The results of the fracture toughness tests, K_{IC} , are shown in Tables 21 through 25. These data generally indicate that there is an increase in toughness as the product thickness decreases. While the L-T data for the 7475-T7351 contract plate seem to suggest a decrease as the plate thickness decreases, this results from the use of relatively small specimens in which large-scale yielding is obtained. The same trend is suggested

by the T-L data for the same plate less than 2 in. in thickness. In fact, the K_Q values obtained with the smaller sizes of specimens are not indicative of the high levels of toughness of this alloy[33].

In order to obtain more meaningful estimates of the toughness of the current production plate (Table 24), the plan-view dimensions, W and 2H (Fig. 3), were increased for the L-T and T-L specimens in accordance with the guidelines developed by Kaufman[33] and shown in Aluminum Association Document T-5[34]. Kaufman showed that for a given lot of plate, essentially the same value of K (K_Q or K_{Ic}) is obtained with different thicknesses of specimen of a given plan size, so that if a specimen plan size is selected on the basis of obtaining valid data for thick specimens (i.e., $a \geq 2.5 \left(\frac{K_{Ic}}{y_s}\right)^2$ and $\frac{P_{max}}{P_Q} \leq 1.1$) estimates of toughness can be obtained with relatively thin specimens. In these tests, W and 2H were 4 and 4.8 in., respectively, for the T-L specimens of the 0.50 and 0.75-in. plate and 6 and 7.2 in., respectively, for the remaining L-T and T-L specimens from plate up to 3.50-in. thick. With the exception of the 0.50 and 0.75-in. specimens, all dimensions were within the standard or alternative limits specified by ASTM E399.

On this basis, it is evident from data in Table 24 that the toughness of 7475-T7351 plate less than about 2 in. in thickness, like that for thicker plate of all of the alloys tested, increases as thickness decreases. To ascertain that the difference in toughness indicated between the contract plate and the current

production plate were not solely a specimen size effect, similar large plan-size specimens from the 0.50 and 1.00-in. contract plate were also tested. The results are summarized below for the two groups of thin 7475-T7351 plate:

Thickness, in.	K_Q , ksi $\sqrt{\text{in.}}$ (Large Plan View Specimens)			
	L-T		T-L	
	Current	Contract	Current	Contract
0.50	60.0	53.6	42.6	40.5
0.75	58.9	--	43.7	--
1.00	--	<u>51.6</u>	--	<u>38.0</u>
Average	59.4	52.6	43.2	39.2

The above K_Q values for the current production plate average about 10 per cent higher than those obtained for the contract plate, and comparison of K_{Ic} values for the thicker plate (Tables 23 and 24) show similar differences. The plots of K_{Ic} versus yield strengths in Fig. 18 show that, for the levels of yield strength, the fracture toughness of the contract plate is outside the ranges of data for material produced with current optimum fabricating practices as well as those for plate fabricated prior to the contract[35]. Consequently, for reasons discussed in Section II, Materials, the levels of toughness developed by the contract plate are not indicative of the capabilities of current production, and so K_{Ic} values for the newer lots (Table 24) should be used in establishing the levels of toughness to be expected for 7475-T7351 at present and in the future.

Average values of K_{Ic} , including K_Q values considered meaningful in Tables 21 through 25, are summarized as follows:

Alloy and Temper	Product	Thickness Range, in.	K_{Ic} , ksi $\sqrt{in.}$		
			L-T	T-L	S-L
2048-T851	Plate	1.0-4.0	38.0	30.6	25.4
7050-T7351	Plate	2.0-4.0	37.0	31.2	28.2
		5.0-6.0	31.4	27.7	27.5
7475-T7351 ^(a)	Plate	1.75-3.5	50.2	37.4	32.9
2219-T852	Hand Forgings	2.0-7.5	39.3	27.3	24.6

(a) Current Practice (Table 24) for contract plate (Table 23), 1.0-4.0 in. thick, values average: 45.1 (L-T), 33.3 (T-L) and 29.6 (S-L).

The K_{Ic} data (valid and meaningful values) for the 2048, 7050 and 7475 (current practice) plate are plotted in Fig. 19. The shaded areas indicate ranges of 2124-T851 plate and other 2XXX and 7XXX plate data. Most of the data points are, at comparable yield strengths, above the data represented by the shaded areas, the largest differences being for the L-T orientation. The 7475-T7351 values for the L-T orientation are twice the 2XXX and 7XXX mid-range data and the highest of all the three plate alloys tested. A similar comparison of data is made in Fig. 20 for the 2219-T852 hand forgings. The level of toughness for relatively large 2219-T852 hand forgings (up to 7.5 x 22 in.) is within, or a little above, the range for smaller sizes of forgings of other alloys, but the yield strengths are in the low end of the range.

A.3. Axial-Stress Fatigue

The results of the axial-stress fatigue tests (ambient-air environment, $R = 0.0$) of smooth and notched, $K_t = 3$, specimens are plotted in Figs. 21 through 30. Prior to this investigation no fatigue data were developed for the short-transverse directions of other alloys so short-transverse comparisons cannot be made. Generally, the fatigue strengths for short-transverse specimens of plate, from 10^6 to 10^7 cycles, are about 2/3 to 3/4 of the strengths for longitudinal and long-transverse specimens. For 2219-T852 hand forgings, the data for the three test directions are about the same.

2048-T851 Plate (Smooth-Fig. 21 and Notched-Fig. 22)

The data for smooth specimens are generally comparable to, or beyond 10^6 cycles a few ksi higher than, those of 1-3/8-in. thick 2024-T851 plate[2]. The data for both smooth and notched specimens indicate the fatigue strengths of 2048-T851 plate to be somewhat higher than those represented by the curve for 2124-T851 plate[9], but they are in the same range as other data indicated by the bands[35]. Beyond 10^6 cycles, the data for smooth specimens of the 1 and 2-in. thick 2048-T851 plate and, beyond 10^5 cycles, the data for notched specimens are in the upper half of the respective bands.

7050-T7351 Plate (Smooth-Fig. 23 and Notched-Fig. 24)

For smooth specimens the data are comparable to data of 7050-T73651 plate[10]. Relative to 7075-T7351 plate[1, 35], 1.25 to 1.75-in. (Fig. 25), the data for 2 to 6-in. thick 7050-T7351 plate fall at the bottom of the 7075 band, except at 10^7 cycles where the data are at the center of the band.

Most of the fatigue data for notched specimens are within the band for 7050-T73651 plate, 2 to 6-in. thick. This band was based on a small number of tests and the upper end of the range at 10^7 cycles was established from two data points (L and LT) for 2-in. thick plate[10].

7475-T7351 Plate (Smooth-Fig. 25 and Notched-Fig. 26)

The data up to 10^6 cycles for smooth specimens (L and LT) of the 1 to 4-in. thick contract plate fall at the bottom of the band for 7075-T7351 plate, 1.25 to 1.75-in.[1, 35]. At 10^7 cycles the data for the 1 and 2-in. plate are near the center and for the 3 and 4-in. plate in the lower half of the band.

For notched specimens the data are comparable at stresses from 20 ksi and above, but average a few ksi below the curve for 1.375-in. thick 7075-T7351 plate[32] at stresses below 20 ksi.

7475-T7351 Plate, Current Practice (Smooth-Fig. 27 and Notched-Fig. 28)

Fatigue strengths at 10^6 to 10^7 cycles for both smooth and notched specimens from plate produced by current practices are higher than those of the contract data represented by the bands (L and LT) and the curve (ST). Although based on limited data, the improvement in fatigue strength for the short-transverse direction appears to be appreciable. The strengths (L and LT) are comparable to those of 7075-T7351 plate.

2048-T851, 7050-T7351, and 7475-T7351 Plate

Average fatigue strengths for the three plate alloys generally show a spread of no more than 2 to 3 ksi. An exception is that a wider spread is indicated in the average strengths beyond 10^5 to

10^7 cycles for notched short-transverse specimens; at 10^7 cycles the fatigue strength for 2048 is about 11 ksi and for 7050 and the contract 7475 is 7.5 and 7 ksi, respectively.

As discussed previously, the 7475-T7351 plate fabricated by current practices developed higher fatigue strengths than the contract 7475 plate. The strengths are also equivalent to or higher than those of 7050 and 2048, with the exception that for short-transverse notched specimens the fatigue strength at 10^7 cycles is 9 ksi compared to 11 ksi for 2048.

2219-T852 Hand Forgings (Smooth-Fig. 29 and Notched-Fig. 30)

Except at the high stress levels, the data for smooth specimens are within the band for 2219-T8-type plate[35]. At about 10^7 cycles the fatigue strengths are a little below those indicated by the curves for 2014-T652 and 2024-T852 hand forgings[6].

There are no hand forging data for comparison of tests of notched specimens; the fatigue strengths are equivalent to those of 2124-T851 plate (Fig. 22).

B. Fatigue Crack-Propagation Tests

The fatigue crack-propagation plots have a scale for stress intensity which emphasizes differences but also emphasizes scatter in the test data. Some of the plots show substantial scatter and overlap. Accordingly, differences in fatigue crack-growth rates of less than 50 per cent as summarized in Table 26 are not considered significant for product comparisons. In both dry-air and sump-water environments, though not in moist air, there is a general tendency for the tests at slower frequencies to

show somewhat faster propagation. The effects of the other variables are discussed below:

2048-T851 Plate (Figs. 31 to 36)

1. At the higher stress intensities the L-T specimens had lower rates of propagation in dry air than the T-L or S-L specimens.
2. Propagation rates in sump water were generally two to three times faster than those in dry air; however, the T-L specimens from the 1.0-in. plate exhibited little environmental effect at high stress intensities.
3. Good agreement between the results of tests of 1/4-in. and 1.0-in. specimens is shown in Figs. 34 and 35 for tests in dry air and sump water, respectively.
4. The rates of propagation for T-L specimens in the thick plate are similar to those reported for 2124-T851 plate[9].

7050-T7351 Plate (Figs. 37 to 42)

1. The rates obtained for the two plate thicknesses and three orientations are essentially equivalent.
2. Fatigue-crack propagation rates in moist air and sump water were generally about 1-1/2 and 2 to 5 times faster, respectively, than rates in dry air.
3. The crack in the low-growth-rate T-L specimen tested in sump water (Fig. 41) stopped twice and crack'ng had to be reinitiated at higher loads.

4. The low-growth rate T-L specimen from the 4-in. plate (Fig. 40) was the only T-L specimen which had crack-front angulation; the rates determined for this tests are slower than those shown for the thicker, high-growth rate specimen.
5. The rates of propagation are comparable to those reported for 7050-T73651 plate in dry and moist air[10].

7475-T7351 Contract Plate (Figs. 43 to 48)

1. Compared to propagation in dry air, propagation is two to three times as fast in moist air and three to eight times as fast in sump water for all orientations.
2. The rates of propagation do not vary significantly with plate thickness or specimen orientation.
3. Figure 46 shows good agreement between rates determined for the 1/4-in. and 1-in. thick specimens tested in dry air.
4. Relatively slow rates of propagation were obtained for the 1/4-in. thick specimen in sump water (Fig. 47) at the low-stress intensities. Attempts to start the tests at lower stress intensities had resulted in crack arrest.

7475-T7351 Current Production Plate (Figs. 49 to 52)

1. The rates of propagation in the T-L and S-L specimens from the current production lots of 7475-T7351 plate were generally similar to those determined for the comparable contract materials.
2. The 1/4-in. T-L specimen tested in dry air had somewhat slower propagation than the 1-in. T-L specimen (Fig. 50).

3. The propagation of a 1/4-in. thick specimen (Fig. 51) stopped after sump water was added to a crack initiated at a low-growth rate in laboratory air.

2219-T852 Hand Forging (Figs. 53 to 58)

1. The rates of propagation at the higher stress intensities were slow for the L-T specimens from the larger hand forging (Fig. 55).
2. Equivalent rates of propagation were obtained for T-L specimens taken from the surface and T/2 locations (Fig. 56).
3. The rates of propagation were 1-1/2 to 2 times as fast in moist air as in dry air and about 3 times as fast in sump water as in dry air at medium stress intensities.
4. At low-stress intensities, rates of propagation were much slower in sump water (Fig. 57) than in dry air (Fig. 56). An attempt to obtain sump water data at a somewhat lower stress intensity resulted in crack arrest.
5. The large 2219-T852 hand forging did not show the large directional effect reported for the comparable 7050-T73652 hand forging[10]. Also rates are slower than reported for a large 7175-T736 hand forging[9].

Comparison of Products and Alloys

1. In moist air, propagation was similar for the hand forging and three plate alloys.
2. At medium and high stress intensities, Fig. 59 shows the propagation in sump water to be faster in 7050-T7351 and 7475-T7351 plate than in 2048-T851 plate; the environmental

effect was greatest for 7475-T7351 plate. At medium stress intensities, rates of propagation in sump water were comparable for 2048-T851 plate and 2219-T852 hand forgings.

3. At low stress intensities propagation in sump water slowed or arrested in alloys 7050-T7351, 7475-T7351, and 2219-T852 but not 2048-T851. Metallographic and scanning electron microscopic (SEM) examinations were made of a 7475-T7351 specimen whose crack arrested after 0.01 to 0.02 in. propagation in sump water. Before the sump water was added, the crack had been propagating in air at a slow rate (5×10^{-8} in/cycle). SEM examination, Fig. 60, showed that the "river markings," characteristic of Stage 1 propagation, were fanning out and formed scalloped crack fronts in the latter stages of the sump water propagation. SEM examination further revealed that the fracture surface was heavily contaminated with corrosion product. The primary elements in the product (as determined by X-ray analysis) were Cd and Cl, which are the predominant components of the sump water. Examination of the unloaded specimen had shown the crack to be wider in the tip region after the loadings in sump water than after the loadings in air. By partially filling the crack, the buildup apparently increased the load at which crack closure occurred; i.e., the crack was closed for a larger portion of the load cycle. Thus, the effective range of load and stress intensity was decreased. Depending on relative rates of buildup and propagation, progressive buildup of the corrosion product could slow or arrest the crack.

4. In each environment the rates of propagation were generally comparable for the 7050-T7351 and 7475-T7351 plate specimens irrespective of specimen orientation.
5. The 2048-T851 plate and 2219-T852 hand forgings showed more of a directional effect, with relatively slow rates shown at high-stress intensities for L-T specimens.

C. Corrosion Characteristics

C.1. Resistance to Exfoliation

All products except the 2.5-in. thick 2219-T852 hand forging (S. No. 478817, Table 27) displayed a high resistance to exfoliation in the EXCO immersion test (Tables 27 through 30). Panels from the 7050-T7351 and 2048-T851 alloy plates revealed no evidence of exfoliation. Minor exfoliation (E-A) was detected on panels from the other 2219-T852 hand forgings and on the panels from the mid-plane of the 7475-T7351 plate. The development of minor exfoliation of degree E-A in the aggressive EXCO solution is believed to be of no practical importance because it has been shown that products that develop this degree of exfoliation in the accelerated test do not develop any evidence of exfoliation during exposure to the seacoast atmosphere at Point Judith, Rhode Island[36]. The total length of exposure to the EXCO solution was 144 hours for the 2219-T852 panels except for panels from the 2.5-inch thick hand forging and 96 hours for the other alloys. The panels were, however, examined and rated at various time periods including the 48 hour exposure specified in ASTM G34-72[27]. The general appearance and the ratings of the test panels did not change during extension

of the test beyond the specified 48 hours.

Visual examination of the panels from the 2.5-in. thick 2219-T852 hand forging after 48 hours of exposure to the EXCO solution resulted in the panels being given an E-D rating using the photographic standards in ASTM G34-72[27]. Metallographic examination of the test panel from the mid-plane, T/2, did not, however, reveal the lifting of the surface normally associated with a high degree of susceptibility to exfoliation. The metallographic examination of the corroded specimen showed pitting plus intergranular attack with some presence of slip plane attack. The nature of the attack on the 2219-T852 specimens is shown in Figures 61 and 62. From the metallographic examination it would have been expected that the specimen rating would be no worse than E-A. The disparity between the visual and metallographic examination of the 2219-T852 specimen may indicate that the EXCO test presently recommended for 7XXX series alloy may not be entirely satisfactory for 2XXX series alloys.

No evidence of exfoliation was displayed during exposure to the acidified salt spray by any of the panels from selected lots of each product. The absence of any exfoliation in the acidified salt spray on panels from the 2.5-in. thick 2219-T852 hand forging leads to a further questioning of the suitability of the EXCO test for evaluation of the resistance to exfoliation of 2XXX series alloys. On the basis of the metallographic examination of 2219-T852 EXCO panel and the results obtained in the acidified

salt spray it is believed that the accelerated tests indicate a high resistance to exfoliation for all of the tested products.

The results of exfoliation testing of selected lots of each product by exposure to the seacoast atmosphere at Point Judith, Rhode Island are encouraging, but the exposures of up to 570 days are not of sufficient duration to provide conclusive results. These specimens which presently show no evidence of exfoliation will continue to be examined during routine periodic inspection of specimens at this exposure station.

C.2. Resistance to Stress-Corrosion Cracking (SCC) -
Smooth Specimens

None of the longitudinal and long-transverse specimens of the various products failed during exposure to the 3.5 per cent sodium chloride alternate-immersion test (Tables 31 through 34). This demonstrates the excellent resistance to stress corrosion that is expected of these products in these test directions. The losses in tensile properties of longitudinal and long-transverse specimens after 12 weeks of exposure indicate that 7475-T7351 has the highest resistance to general corrosion. The lowest resistance to general corrosion was displayed by 7050-T7351 with an average per cent loss in tensile properties that was about three times that of 7475-T7351. The 2219-T852 and 2048-T851 specimens displayed losses in tensile properties approximately midway between these two extremes. The reductions in tensile properties were about the same for the stressed and unstressed specimens except for 7050-T7351 alloy. The per cent losses in tensile properties of the stressed

7050-T7351 specimens were about 1.5 times the per cent losses obtained for the unstressed specimens.

A 30-day exposure to the 3.5 per cent sodium chloride alternate-immersion test has been commonly used to evaluate the stress-corrosion performance of high-strength aluminum alloy using 0.125-in. diameter, short-transverse tension specimens (Tables 31 through 34). None of the short-transverse specimens exposed to the alternate-immersion test at an applied stress of 50 per cent of the tentative or specified minimum long-transverse yield strength for the tested product lots failed during this 30-day exposure period. Two short-transverse specimens from the 3.0-in. thick 2048-T851 plate (S. No. 421083) did fail with longer exposure. Although longer exposures are necessary to obtain conclusive results none of the short-transverse specimens stressed to 50 per cent of the tentative or specified long-transverse yield strength have failed during atmospheric exposure at Point Judith, Rhode Island or at the Alcoa Technical Center for time periods of up to 496 days (Tables 35 through 38).

After 30 days of exposure to the alternate-immersion test, failure of short-transverse specimens stressed to 75 per cent of the tentative or specified minimum long-transverse yield strength had occurred for three lots of 2048-T851 alloy plate. Both lots of 2.0-in. thick plate (S. No. 421381, 421382) and one lot of 3.0-in. thick plate (S. No. 421083) of 2048-T851 alloy had one of the triplicate specimens failing to complete a 30-day test. These same lots of 2048-T851 alloy plate are the

only lots of any alloy to have experienced specimen failures during exposure at Point Judith, Rhode Island. Continuation of the alternate-immersion testing of the short-transverse specimens stressed at 75 per cent did not result in any failures of the 7475-T7351 alloy specimens and only one failure of the 2219-T852 alloy specimens. However, nine additional specimens of 2048-T851 alloy and six specimens of 7050-T7351 alloy failed during the extended exposure.

Metallographic examination of the two earliest 2048-T851 failures in the alternate-immersion test revealed the failures to be tensile fractures with no evidence of secondary intergranular cracks. Metallographic examination of short-transverse specimens of 2048-T851 alloy that failed after longer periods of exposure did reveal clear evidence of intergranular cracks. The presence of intergranular cracking in these specimens and the failures obtained at Point Judith, Rhode Island, would seem to indicate that the lots of 2.0-in. thick plate and the one lot of 3.0-in. thick plate of 2048-T851 alloy do have some susceptibility to intergranular stress corrosion at the higher stress.

C.3. Resistance to SCC of Precracked Specimens

Table 39 lists the lots of each product that were selected to be tested with the short-transverse (S-L) tension precracked DCB specimens. The initial average crack length, initial total crack-opening displacement (V), and initial stress intensity (K_{I1}) are shown for each individual DCB test specimen. The results of plane-strain fracture toughness tests of the selected materials are also shown. The initial stress-intensity values (K_{I1}) are

in very good agreement with the plane-strain fracture toughness values (K_{Ic}). The DCB specimen geometry used in the tests, Figure 13, is believed to be responsible for this good agreement.

Individual crack-growth curves for the specimens exposed to the 3.5 per cent sodium-chloride solution are presented in Figures 63 through 73. The DCB specimens of 7475-T7351 alloy, Figures 72 and 73, displayed a crack growth that was about the smallest change that can be detected with the Alcoa Technical Center ultrasonic measuring device. The crack growth for the other products showed considerable variability for the various lots and in several cases even between duplicate specimens from the same lot. The most significant crack growth, Figure 66, was experienced with the duplicate specimens from the 2.0-in. thick 2048-T851 plate, but the crack growth was considerably less than that incurred by highly susceptible materials such as 7075-T651 and 7079-T651.

Examination of the crack surface of the specimens at the completion of the 30-day test indicated that the environmental crack growth of most of the specimens was the result of typical intergranular stress-corrosion cracking. The stress-corrosion growth generally proceeded on various planes giving a fracture surface with many small steps. The tendency for flat SCC facets was less with thicker sections making the SCC more difficult to recognize. The presence of actual SCC is, however, questionable for the 4.0-in. thick 7475-T7351 plate and for the 4.5 and 7.5-in. thick 2219-T852 hand forgings. Rough measurements of the

environmental crack growth on the fracture surfaces gave a reasonably good check with the ultrasonic measurements except for the 7475-T7351 and 2219-T852 specimens that had very small amounts of crack growth.

Crack-growth rate versus stress-intensity data were calculated for each of the test specimens. The plateau velocities for the K-rate curves were determined by an arbitrary procedure to avoid the erratic shapes of crack-growth curves during the initiation of SCC and the extraneous effect of corrosion product wedging. The total amount of crack-growth that occurred during the first 360 hours (15 days) of exposure was used to calculate the overall average growth rate for that period. These results are shown in Table 40. This procedure has been found to represent best the initial sustained crack growth which is considered to be one of the most significant features of the K-rate curves. The K_I -rate data for the various products are illustrated in Figure 74. Data for plate of alloys 7079-T651, 7075-T651, and 7075-T7351[32] are included for comparison. The overall average plateau velocity of 1.5×10^{-4} in. per hour for the 7050-T7351 alloy plate is in good agreement with the average plateau velocity obtained for 7050-T73651 plate in previous investigations[37]. The range in plateau velocities of from 2.8×10^{-5} to 4.8×10^{-4} is a somewhat larger variation than previously encountered. This larger variation is due to the greatly different performance of the two lots of 6.0-in. thick 7050-T7351 alloy plate. No explanation is available for the difference in performance of these two lots or

for the unexpectedly large amount of SCC growth encountered with one of the lots. The overall average plateau velocity for the four lots of 7475-T7351 plate was 2.5×10^{-5} in. per hour which compares favorably with the average plateau velocity for 7075-T7351 alloy plate.

The DCB specimen data provide questionable values for the threshold stress intensity due to the fact that the crack growth did not reach an actual arrest during the 30-day test. It is difficult to be sure of a definite arrest because the formation of corrosion products on the surfaces of the precrack and corrosion crack can form wedges that drive the SCC ahead. A 30-day exposure was selected for the present tests on the basis of previous test experience with similar materials. Actually from the environmental crack-growth curves it would appear that a 20-day exposure was sufficient for all specimens except the specimens for the 2.0-in. thick 2048-T851 alloy plate. Therefore, estimates of threshold stress intensities were calculated for the crack lengths at the end of 20 days. These values would be expected to be good estimates of the true threshold stress intensity for samples that give indications of crack arrest or samples that show very low crack-growth rates. The estimates would, however, be overly optimistic for specimens, such as those from the 2.0-in. thick 2048-T851 alloy plate, Figure 66, that continue to show significant crack growth after 20 days of exposure. The estimates of the threshold stress intensity presented in Table 40 demonstrate that except for 2.0-in. thick 2048-T851 alloy plate and one of the lots of 6.0-in.

thick 7050-T7351 alloy plate, all of the products had high estimated threshold stresses that ranged from 89 to 99 per cent of the initial pop-in stress intensity. Although it is questionable whether these values are valid for design considerations, they do provide a basis for comparison of the various alloys and tempers at the selected length of exposure. This is also true for the average velocities listed in Table 40.

The alloys and tempers would, on the basis of the precracked DCB specimen data, be ranked in the following order of decreasing performance, 7475-T7351, 2219-T852, 7050-T7351, and 2048-T851. This is the same ranking order that is obtained from the results of the smooth specimen stress corrosion tests

Effect of DCB Specimen Thickness

Previous tests of 2024-T351 and 7075-T651[32] suggested that crack-growth rates and threshold levels may be independent of the stress state. This suggestion was subjected to further examination by the exposure to 3.5 per cent sodium-chloride solution of reduced thickness DCB specimens, Figure 14, from the center plane of 4.0-in. thick 2048-T851, 7050-T7351, and 7475-T7351 alloy plate. The 1.0-in. thick DCB specimens for which a plane-strain stress was expected had initial stress-intensity values (K_{Ii}) that were in very good agreement with the plane-strain fracture toughness values (K_{Ic}). The initial stress-intensity values shown in Table 41 for the 0.25-in. reduced thickness DCB specimens expected to have a mixed mode stress state, of course, were considerably higher than the fracture toughness

(K_{Ic}) values. The high initial stress intensities were the result of the higher total crack-opening displacement of the reduced thickness specimens.

The crack-growth curves for the reduced thickness specimens are presented in Figures 75 through 84. Figures 77, 80, and 84 compare the environmental crack growth of 1.0, 0.5, and 0.25-in. thick DCB specimens of each plate alloy. The reduced thickness specimens generally showed less crack growth than the 1.0-in. thick specimens. This is especially evident for the 4.0-in. thick 7050-T7351 alloy plate, Figure 80. For the stress-corrosion resistant alloys and tempers in this investigation departure from a plane-strain stress state appears to have a tendency to reduce the calculated crack-growth rates and to give higher estimates for the threshold stress intensity.

Corrosion Data for Current Production Lots of 7475-T7351

The stress-corrosion data for the current lots of 7475-T7351 plate are presented in Tables 42 through 45 and in Figures 85 and 86. These results are in complete agreement with the main body of test results and provide additional evidence of the outstanding resistance to stress corrosion of all of the tested lots of 7475-T7351 plate.

SECTION VI

SUMMARY AND CONCLUSIONS

The mechanical properties, including fracture characteristics and axial-stress fatigue, fatigue crack-growth rates and corrosion characteristics have been evaluated for 2048-T851, 7050-T7351, and 7475-T7351 plate and 2219-T852 hand forgings produced by commercial practices. Based on the data developed in this investigation, the following summary statements and conclusions have been made:

A. Mechanical Properties

A.1. Tensile, Compressive, Shear and Bearing

1. Ratios among the tensile, compressive, shear and bearing properties have been computed. These ratios are suitable for use in developing reduced ratios to establish derived design allowables for inclusion in MIL-HDBK-5.
2. The average modulus of elasticity values developed from stress-strain tests are as follows:

<u>Alloy and Temper</u>	<u>Product</u>	<u>Modulus, 10³ ksi</u>	
		<u>Tension(E)</u>	<u>Compression(E_c)</u>
2048-T851	Plate	10.4	10.7
7050-T7351	Plate	10.3	10.6
7475-T7351	Plate	10.3	10.6
2219-T852	Hand Forgings	10.2	10.4

3. Tensile and compressive stress-strain and compressive tangent-modulus curves have been developed for 2048-T851, 7050-T7351 and 7475-T7351 plate for inclusion in MIL-HDBK-5. Stress-strain data for 2219-T852 hand forgings have been

presented in a form suitable for developing curves when sufficient tensile property data have been obtained from production lots to establish typical tensile yield strengths.

A.2. Fracture Toughness

1. All three alloys of plate developed levels of fracture toughness appreciably higher than other commercial alloys having comparable yield strengths. Alloy 7475 exhibited the highest fracture toughness in all three orientations, particularly for the L-T.
2. The toughness levels of the 7475-T7351 plate, although above current minimum values, were not representative of current production. Data for ten additional lots produced by current production practices (Table 24) demonstrated the high-toughness capabilities expected of this alloy and so these K_{Ic} values should be used in establishing the levels of toughness to be expected for 7475-T7351 at present and in the future.
3. The 2219-T852 hand forgings, sizes up to 7.5 x 22 in., developed the levels of toughness higher than those of most other hand forging alloys, but yield strengths are in the low end of the range.

A.3. Axial-Stress Fatigue

1. The axial-stress fatigue strengths for smooth and notched, $K_t = 3$, specimens are in the same general range as those of corresponding products of 2XXX and 7XXX alloys.

2. Fatigue strengths of the 7475-T7351 plate produced by current production practices are comparable to those of 7075-T7351 plate. The fatigue strengths for the plate tested under the contract are generally lower than those of 7075-T7351 plate.
3. The average fatigue strengths of the three plate alloys are in the same general range except for short-transverse notched specimens ($K_t = 3$); the fatigue strength of the 2048 plate at 10^7 cycles is 11 ksi compared to 9 and 7 ksi for 7475 and 7050, respectively.

B. Fatigue-Crack Propagation

1. In moist air, propagation was similar for the hand forging and the three plate alloys.
2. At medium-stress intensities, crack propagation rates in moist air are 1.5 to 2 times those in dry air, and rates in sump water are 2 to 9 times those in dry air. Propagation in sump water was twice as fast in 7050-T7351 and 7475-T7351 plate as in 2048-T851 plate and 2219-T852 hand forgings. Environmental effects were less at high-stress intensities.
3. At low-stress intensities, propagation in alloys 7050-T7351, 7475-T7351 and 2219-T852 slowed or arrested in sump water. This behavior is attributed to a build-up of corrosion product which effectively reduced the stress intensity range.
4. In both dry air and sump water, though not in moist air, there is a tendency for crack propagation at the slower loading rates to be somewhat faster than at higher loading rates.
5. For the 7050-T7351 and 7475-T7351 plate specimens, rates of propagation are independent of specimen orientation. The 2048-T851 plate and 2219-T852 hand forgings show some

directional effect, with lower rates for L-T specimens at high-stress intensities than for T-L and S-L specimens.

6. In several cases, good agreement was found between growth rates determined for 1/4-in. and 1-in. thick specimens tested in dry air.
7. The rates of propagation determined for the current production lots of 7475-T7351 plate are generally similar to those of the contract materials.
8. The rates of propagation obtained for these alloys in dry and moist environments are generally comparable to reported values for similar aircraft alloys.

C. Corrosion Characteristics

1. All products have a high resistance to exfoliation in the accelerated tests and after up to 570 days in a seacoast atmosphere.
2. All products have the expected excellent resistance to stress corrosion when tested in the longitudinal and long-transverse direction.
3. All products display excellent resistance to stress corrosion in the critical short-transverse direction when tested at an applied stress of 50 per cent of the specified or tentative minimum long-transverse yield strength. The only failures encountered at this stress level were for duplicate specimens of 2048-T851 alloy during extended exposure in the 3.5 per cent alternate-immersion test beyond the normal 30-day exposure.

4. Short-transverse specimens of 7475-T7351, 2219-T852, and 7050-T7351 display excellent resistance to stress corrosion at an applied stress of 75 per cent of the specified or tentative minimum long-transverse yield strength. One specimen of 2219-T852 alloy and six specimens of 7050-T7351 alloy failed during extended exposure in the 3.5 per cent sodium-chloride alternate-immersion test (>30 days).
5. Short-transverse specimen failures in less than thirty days in the alternate-immersion test and specimen failures in the seacoast environment at Point Judith demonstrate that the lots of 2.0-in. thick plate and one lot of 3.0-in. thick plate of 2048-T851 alloy do have some susceptibility to intergranular stress corrosion at an applied stress of 75 per cent of the minimum long-transverse yield strength.
6. Tests of precracked DCB specimens showed the same general trends as tests with smooth specimens and result in the following ranking in order of decreasing performance: 7475-T7351, 2219-T852, 7050-T7351, and 2048-T851.
7. Testing of reduced thickness DCB specimens using tensile pop-in precracking indicates that the stress state can have an effect on the crack-growth rate and estimated threshold stress intensity values for the stress corrosion resistant alloys and tempers evaluated in this investigation.

REFERENCES

1. J. G. Kaufman, G. E. Nordmark and B. W. Lifka, "Fracture Toughness, Fatigue and Corrosion Characteristics of 7075-T651, 7075-T7351 and 7079-T651 Aluminum Alloys," Technical Report AFML-TR-65-170, May 1965.
2. J. G. Kaufman, G. E. Nordmark and B. W. Lifka, "Fracture Toughness, Fatigue and Corrosion Characteristics of 2020-T651, 2024-T851, 2219-T851 and 7001-T75 Aluminum Alloys," Technical Report AFML-TR-66-291, September 1966.
3. D. J. Brownhill, R. E. Davies and D. O. Sprowls, "Mechanical Properties, Including Fracture Toughness and Fatigue, and Resistance to Stress Corrosion Cracking, of Stress-Relieved Stretched Aluminum Alloy Extrusions," Technical Report AFML-TR-68-34, February 1968.
4. J. T. Staley, "Investigation to Improve the Stress-Corrosion Resistance of Aluminum Aircraft Alloys Through Alloy Additions and Specialized Heat Treatment," Final Report under Naval Air Systems Command Contract N00019-68-C-0146, February 1969.
5. J. T. Staley, "Investigation to Develop a High-Strength, Stress-Corrosion Resistant Aluminum Aircraft Alloy," Final Report under Naval Air Systems Command Contract N00019-69-C-0292, January 1970.
6. D. J. Brownhill, C. F. Babilon, G. E. Nordmark and D. O. Sprowls, "Mechanical Properties Including Fracture Toughness and Fatigue, Corrosion Characteristics and Fatigue Crack Propagation Rates of Stress-Relieved Aluminum Alloy Hand Forgings," Technical Report AFML-TR-70-10, February 1970.
7. J. T. Staley, "Investigation to Develop a High-Strength, Stress-Corrosion Resistant Naval Aircraft Alloy," Final Report under Naval Air Systems Command Contract N00019-70-C-0118, November 1970.
8. J. T. Staley, "Further Development of Aluminum Alloy X7050," Final Report under Naval Air Systems Command Contract N00019-71-C-0131, May 1972.
9. C. F. Babilon, R. H. Wygonik, G. E. Nordmark and B. W. Lifka, "Mechanical Properties, Fracture Toughness, Fatigue, Environmental Fatigue Crack Growth Rates and Corrosion Characteristics of High Toughness Aluminum Alloy Forgings, Sheet and Plate," Technical Report AFML-TR-73-83, April 1973.

10. R. E. Davies, G. E. Nordmark and J. D. Walsh, "Design Mechanical Properties, Fracture Toughness, Fatigue Properties, Exfoliation and Stress-Corrosion Resistance of 7050 Sheet, Plate, Hand Forgings, Die Forgings and Extrusions," Naval Air Systems Command Contract N00019-72-C-0512, July 1975.
11. J. T. Staley, J. E. Jacoby, R. E. Davies, G. E. Nordmark, J. D. Walsh and F. R. Rudolph, "Aluminum Alloy 7050 Extrusions," AFML-TR-76-129, March 1977.
12. Military Standardization Handbook, Metallic Materials and Elements for Aerospace Vehicle Structures, Volume 1, August 29, 1975.
13. "Standard Methods of Verification of Testing Machines, E4-76," 1976 Book of ASTM Standards, Part 10.
14. G. W. Stickley and D. J. Brownhill, "Mechanical Properties of Stress-Relieved Stretched Aluminum Alloy Plate," Technical Report AFML-TDR-64-105, May 1964.
15. "Standard Methods of Tension Testing Wrought and Cast Aluminum and Magnesium Alloy Products, B557-74," 1976 Book of ASTM Standards, Part 7.
16. "Standard Methods of Tension Testing of Metallic Materials, E8-69," 1976 Book of ASTM Standards, Part 10.
17. "Standard Methods of Compression Testing of Metallic Materials, E9-70," 1976 Book of ASTM Standards, Part 10.
18. R. E. Davies and J. G. Kaufman, "Effects of Test Method and Specimen Orientation on Shear Strengths of Aluminum Alloys," ASTM Proceedings, Vol. 64, 1974, pp. 999-1010.
19. "Standard Method for Pin-Type Bearing Test of Metallic Materials, E238-68," 1976 Book of ASTM Standards, Part 10.
20. "Standard Method for Determination of Young's Modulus at Room Temperature, E111-61," 1976 Book of ASTM Standards, Part 10.
21. "Standard Method of Verification and Classification of Extensometers, E83-67," 1976 Book of ASTM Standards, Part 10.

22. "Standard Method of Test for Plane-Strain Fracture Toughness of Metallic Materials, E399-74," 1976 Book of ASTM Standards, Part 10.
23. "Tentative Method of Test for Constant-Load-Amplitude Fatigue Crack Growth Rates Above 10^{-8} in./cycle," ASTM Tentative Standard EXXXX.
24. "Elastomers for Fuel Systems Containing Micro-organism-controlling Additives," AFML Technical Documentary Report No. RTD-TDR-63-4195, Part II, January 1965.
25. W. G. Clark, Jr., ASTM E24.4, "Fatigue Crack Growth Rate Testing Round Robin Program," Task Group Progress Report No. 3, May 14, 1971.
26. E. T. Wessel, "State of the Art of the WOL Specimen for K_{Ic} Fracture Toughness Testing," Journal of Engineering, Fracture Mechanics, Vol. 1, No. 1, June 1968, p. 77.
27. "Standard Method of Test for Exfoliation Corrosion Susceptibility in 7XXX Series Copper-Containing Aluminum Alloys (EXCO Tests)," G34-72, 1976 Book of ASTM Standards, Part 10.
28. B. W. Lifka and D. O. Sprowls, "An Improved Exfoliation Test for Aluminum Alloys," Corrosion, Vol. 22, No. 1, 1966, pp. 7-15.
29. "Standard Recommended Practice for Alternate Immersion Stress Corrosion Testing in 3.5% Sodium Chloride Solution," G44-75, 1976 Book of ASTM Standards, Part 10.
30. "Federal Test Method Standard No. 151b," November 1967.
31. M. V. Hyatt, "Use of Precracked Specimens in Stress-Corrosion Testing of High-Strength Aluminum Alloy," Corrosion, Vol. 26, No. 11, November 1970, pp. 487-503.
32. D. O. Sprowls, M. B. Shumaker, J. D. Walsh and J. W. Coursen, "Evaluation of Stress-Corrosion Crack Susceptibility Using Fracture Mechanics Techniques," Final Report - Part I, May 31, 1973, prepared for George C. Marshall Space Flight Center, Contract No. NAS 8-21487.

33. J. G. Kaufman and F. G. Nelson, "More on Specimen Size Effects in Fracture Toughness Testing," ASTM STP 559, American Society for Testing and Materials, 1974, pp. 74-85.
34. J. G. Kaufman, R. L. Lake, G. Schmauch and R. E. Zinkham, "The Aluminum Association Position on Fracture Toughness Requirements and Quality Control Testing," An Interim Report, T-5, September 1974.
35. Unpublished Data, Alcoa Laboratories.
36. B. W. Lifka and D. O. Sprowls, "Relationship of Accelerated Test Methods for Exfoliation Resistance in 7XXX Series Aluminum Alloys with Exposure to a Seacoast Atmosphere," Corrosion in Natural Environments STP 558, American Society for Testing and Materials, 1974, pp. 306-333.
37. D. O. Sprowls, J. W. Coursen and J. D. Walsh, "Evaluating Stress-Corrosion Crack-Propagation Rates in High Strength Aluminum Alloys with Bolt Loaded Precracked Double-Cantilever-Beam Specimens," Stress Corrosion-New Approaches, ASTM STP 610, American Society for Testing and Materials, 1976, pp. 143-156.

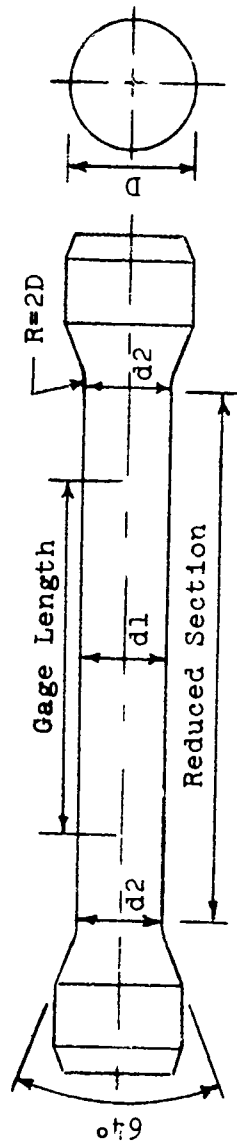

Diameter, in.		Gage Length, in.	Reduced-Section Length, in.	Diameter, (D) in.
d1	d2			
0.500±0.005	d1+0.005 d2+0.003	2.0	3-1/8	3/4
0.357±0.00	d1+0.004 d2+0.003	1.4	2-15/64	17/32
0.250±0.00	d1+0.002 d2+0.001	1.0	1-9/16	3/8
0.160±0.002	d1+0.002 d2+0.001	0.64	1	15/64

Tensile Specimen

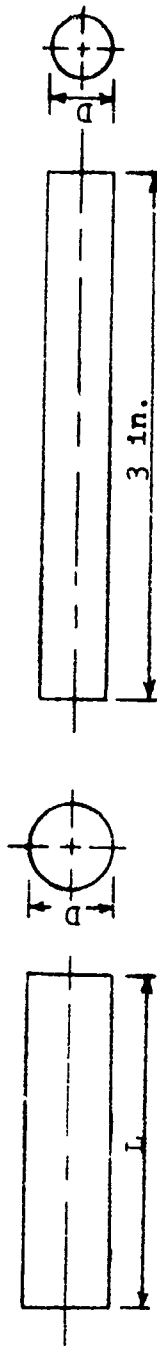

Nominal Diameter, in.	Diameter, (D) in.	Length, (L) in.
3/4	0.7515 0.7485	3
1/2	0.4980 0.4950	1-7/8

Compressive Specimen

Nominal Diameter, in.	Diameter, (D) in.
3/8	0.3730 0.3720

Shear Specimen

Fig. 1 General Dimensions of Tensile, Compressive and Shear Specimens

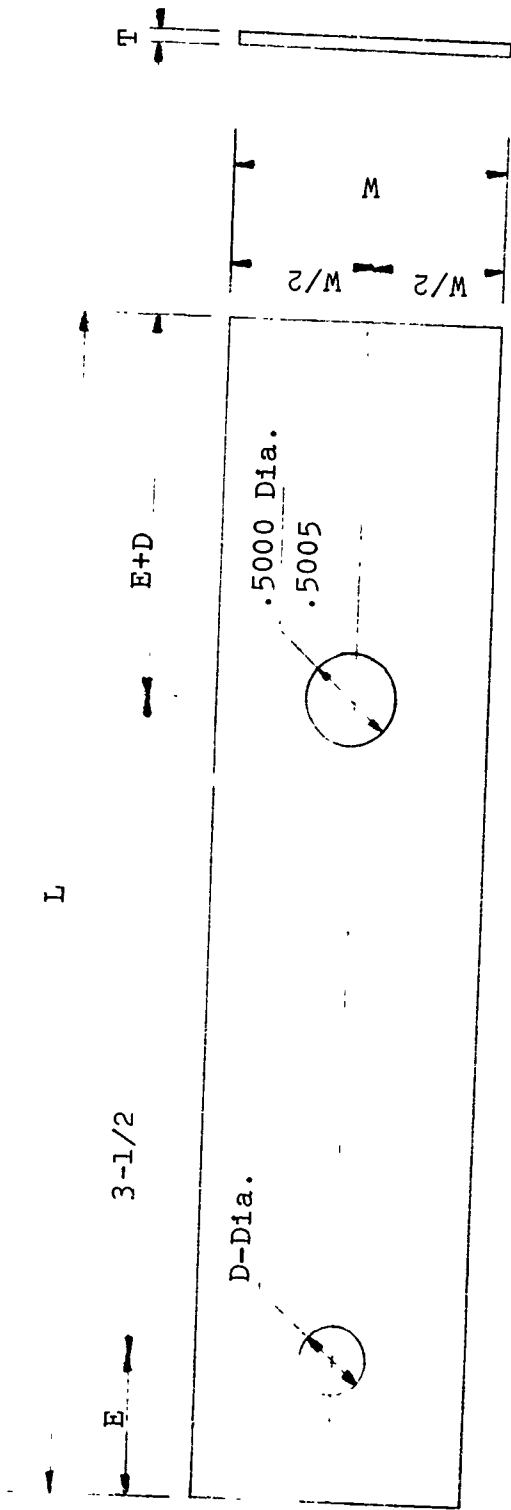

Specimen Type	T, in.	W, in.	W/2, in.	L, in.	D, in.	E, in.	E/D
E/D=1.5	0.094	1.496	0.748	5	0.3750	0.5615	1.5
		1.504	0.752		0.3755	0.5635	
E/D=2.0	0.094	1.496	0.748	5-3/8	0.3750	0.749	2.0
		1.504	0.752		0.3755	0.751	

Fig. 2 General Dimensions of Bearing Specimens

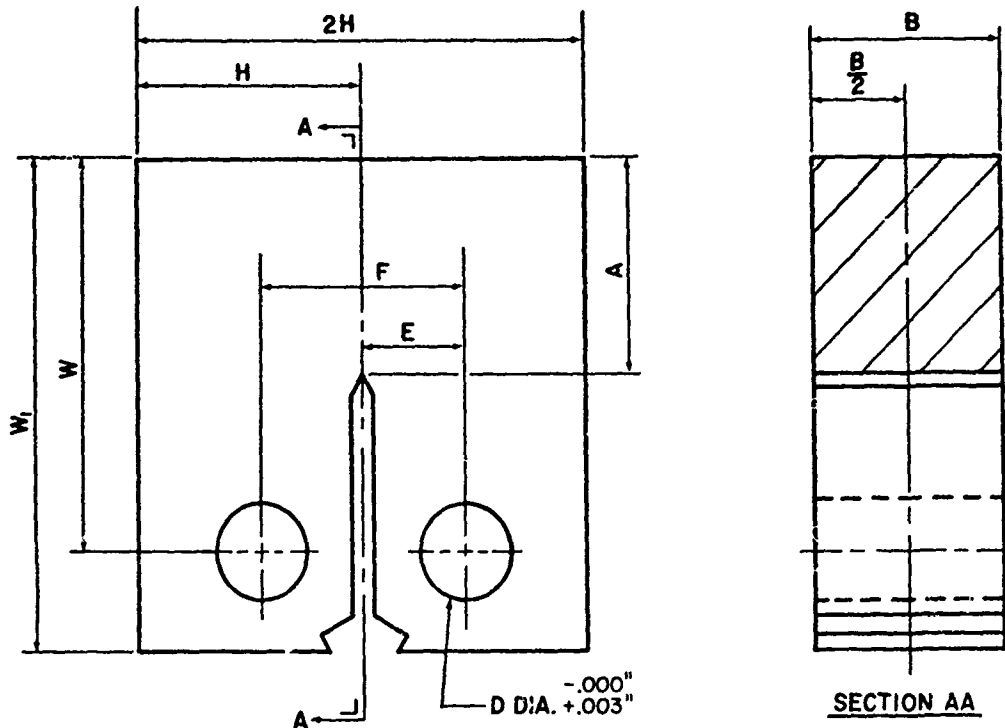

.010" R MAX
(NOTCH ROOT RADIUS)
FATIGUE CRACK TO EXTEND
0.1" BEYOND NOTCH TIP

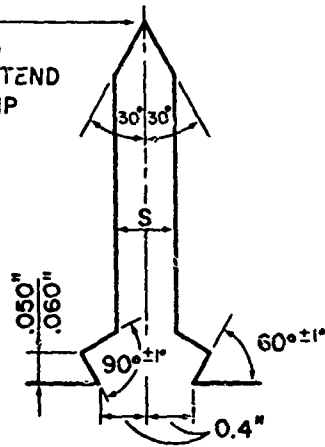

PROPORTIONS

- B = THICKNESS
- A = 1.1 B
- W = 2B; $W_1 = 2.5 B$
- S = 0.1 B
- F = 2E = 1.10B
- H = 1.2 B
- D = 0.5 B

NOTCH ENLARGED VIEW

Fig. 3 COMPACT FRACTURE TOUGHNESS SPECIMEN

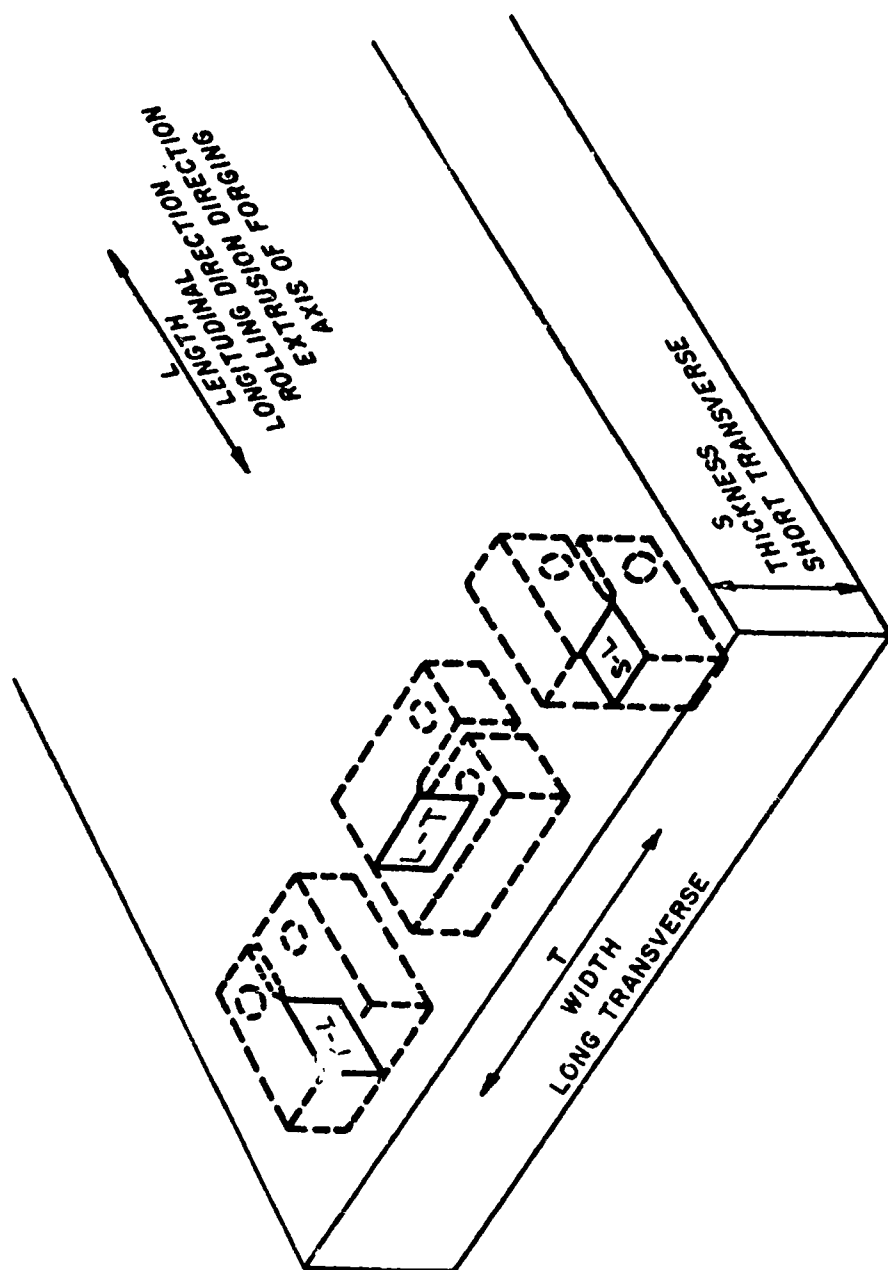

FIG. 4 FRACTURE SPECIMEN ORIENTATIONS

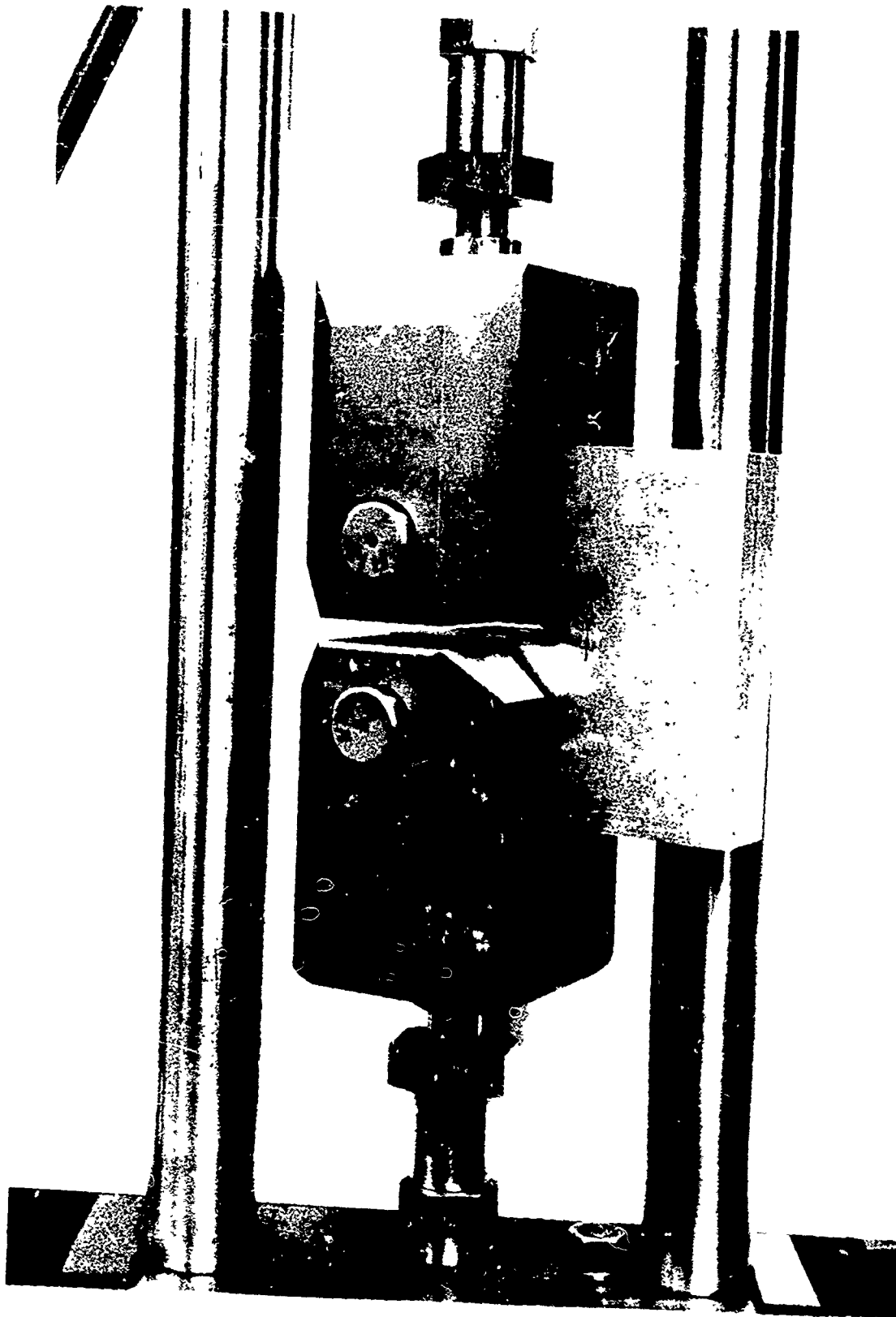

Fig. 5 Setup for Fatigue Precracking of Compact Fracture Toughness Specimens.

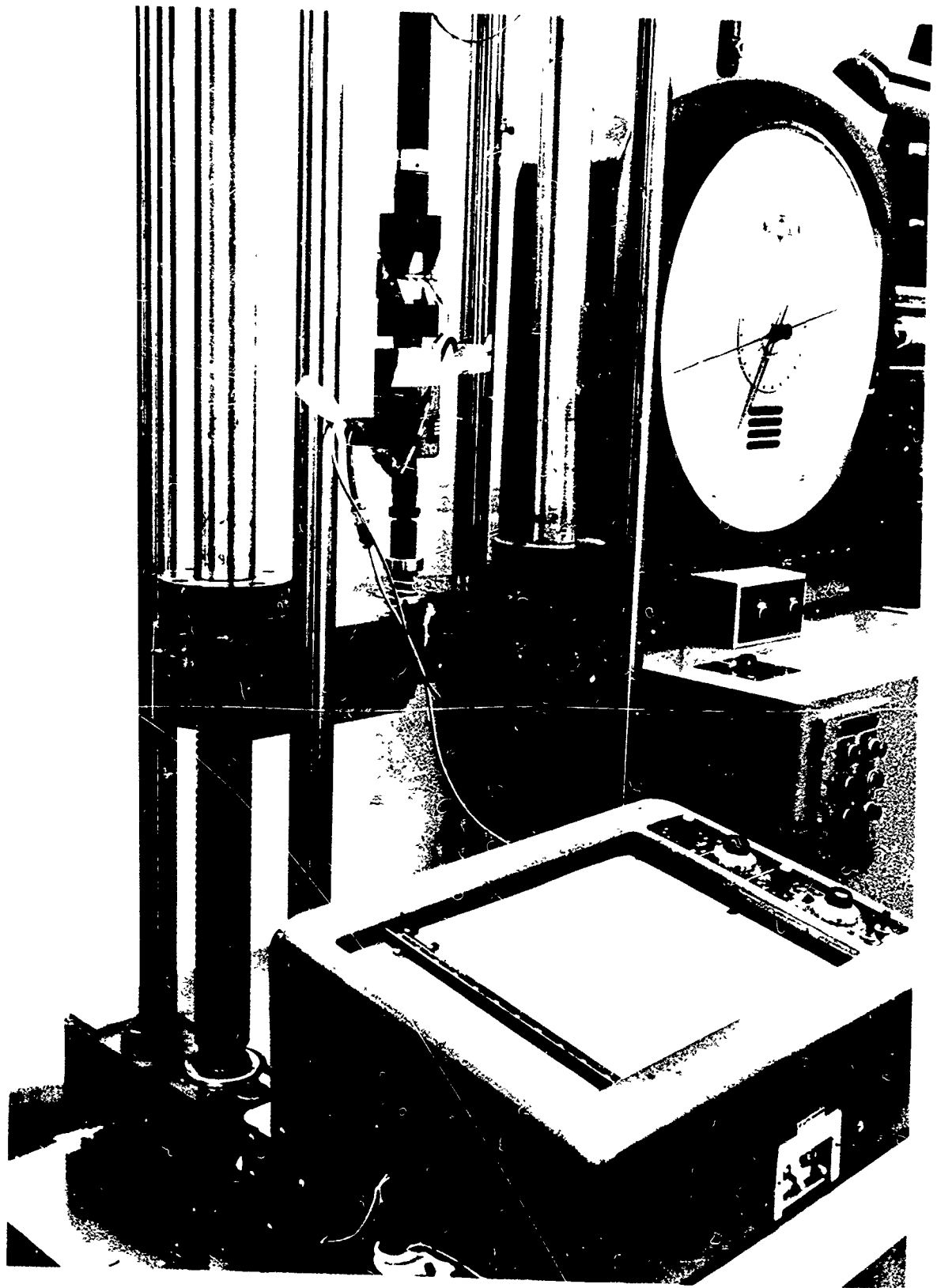
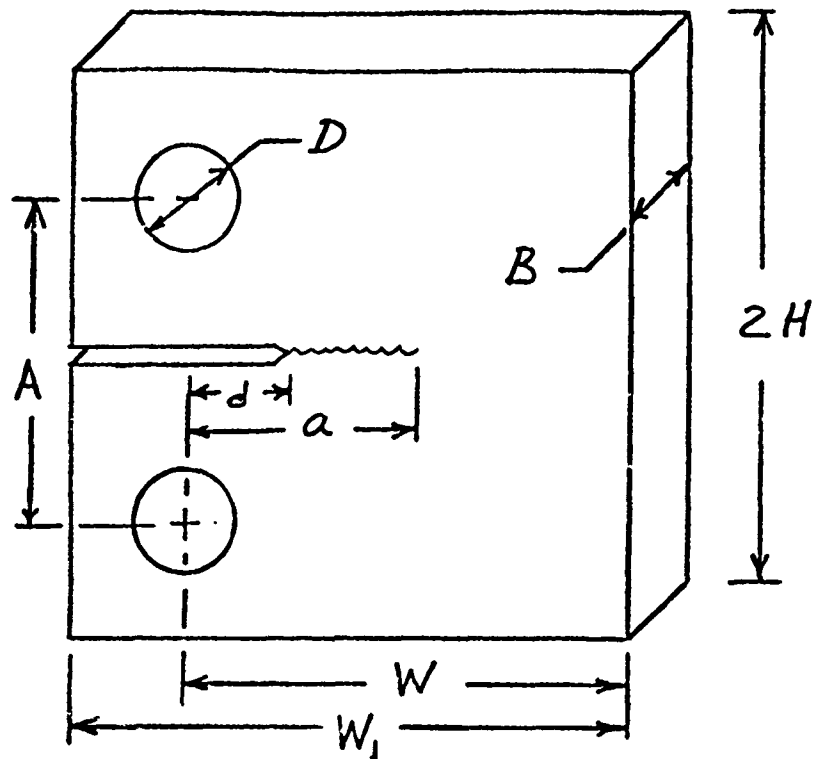

Fig. 6 Setup for Testing Compact Fracture Toughness Specimens.



a = crack length

Special Dimensions - Inches

B	2H	W	A	D	d	W_1	H/W
1.00	3.72	3.805	1.650	0.75	1.151	4.80	0.485
1.00	3.72	3.100	1.650	0.75	1.151	4.10	0.6
0.25	2.48	2.550	1.100	0.375	0.62	3.200	0.485

Fig. 8 Dimensions for Compact Fatigue Crack-Propagation Specimen

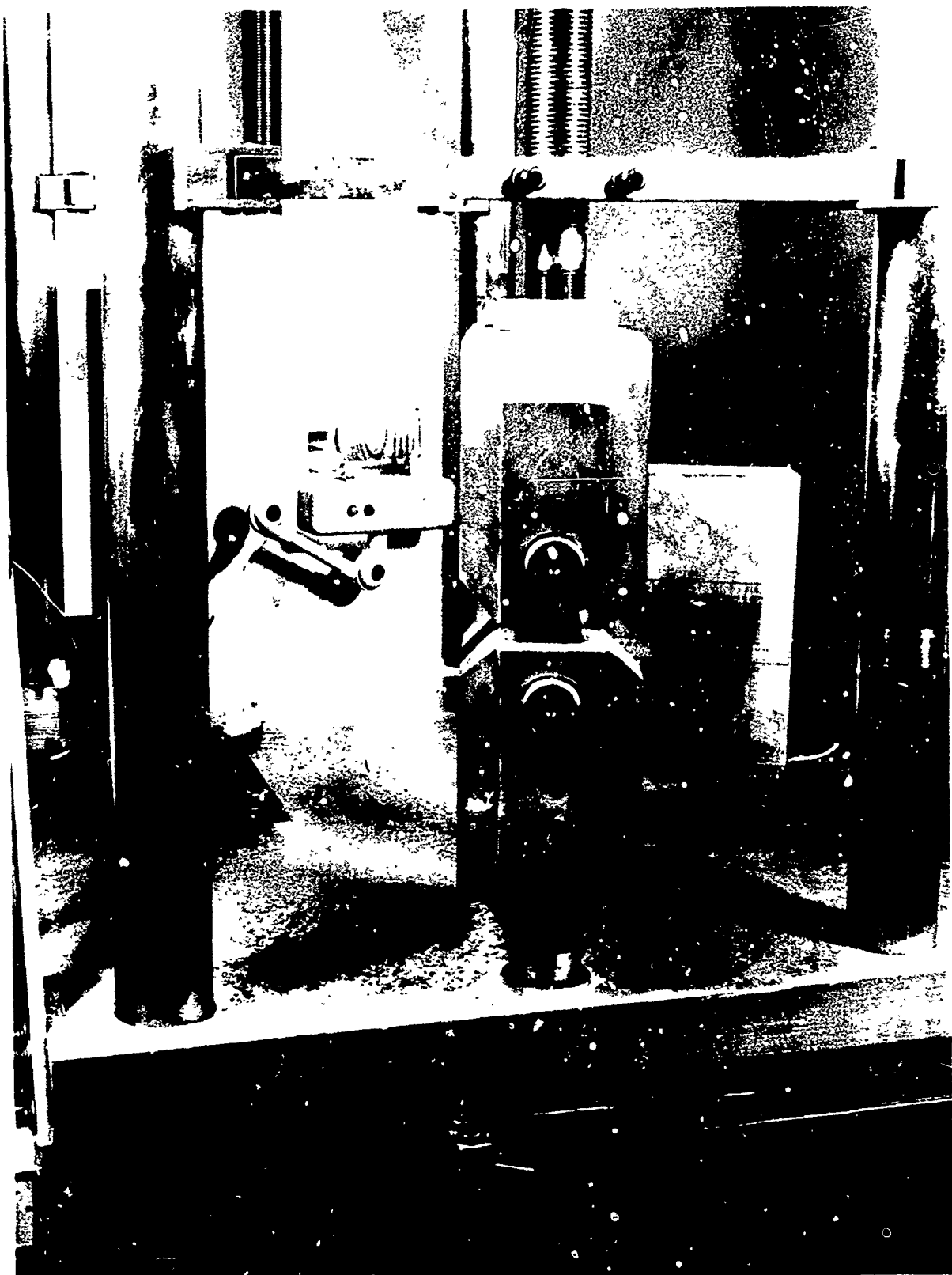

Fig. 9 Fatigue Crack-Growth Tests of Compact Specimens.



E-A



E-B



E-C



E-D

Fig. 10 Four Degrees of Severity of Exfoliation Corrosion
Per ASTM Standard Method Test G34-72.

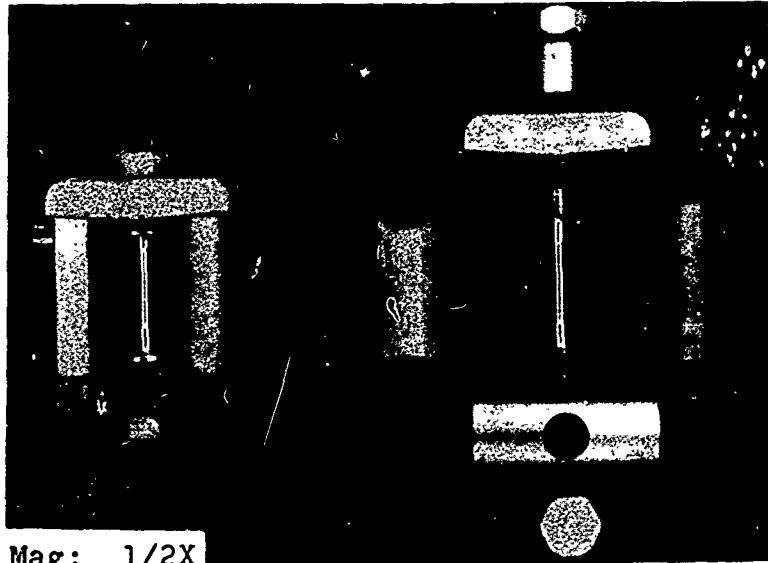

Mag: 1/2X

Fig. 11 1/8-in. Diameter Tensile Specimen, Various Parts of the Stressing Frame and Final Stressed Assembly for Stress Corrosion Tests.

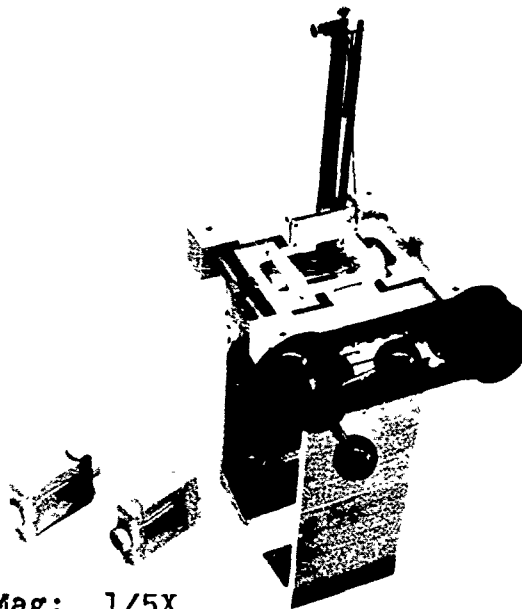

Mag: 1/5X

Fig. 12 Synchronous Loading Device Used to Stress Specimens Stressed Assembly and One Assembled Finger Tight Ready For Stressing Are Shown to the Left.

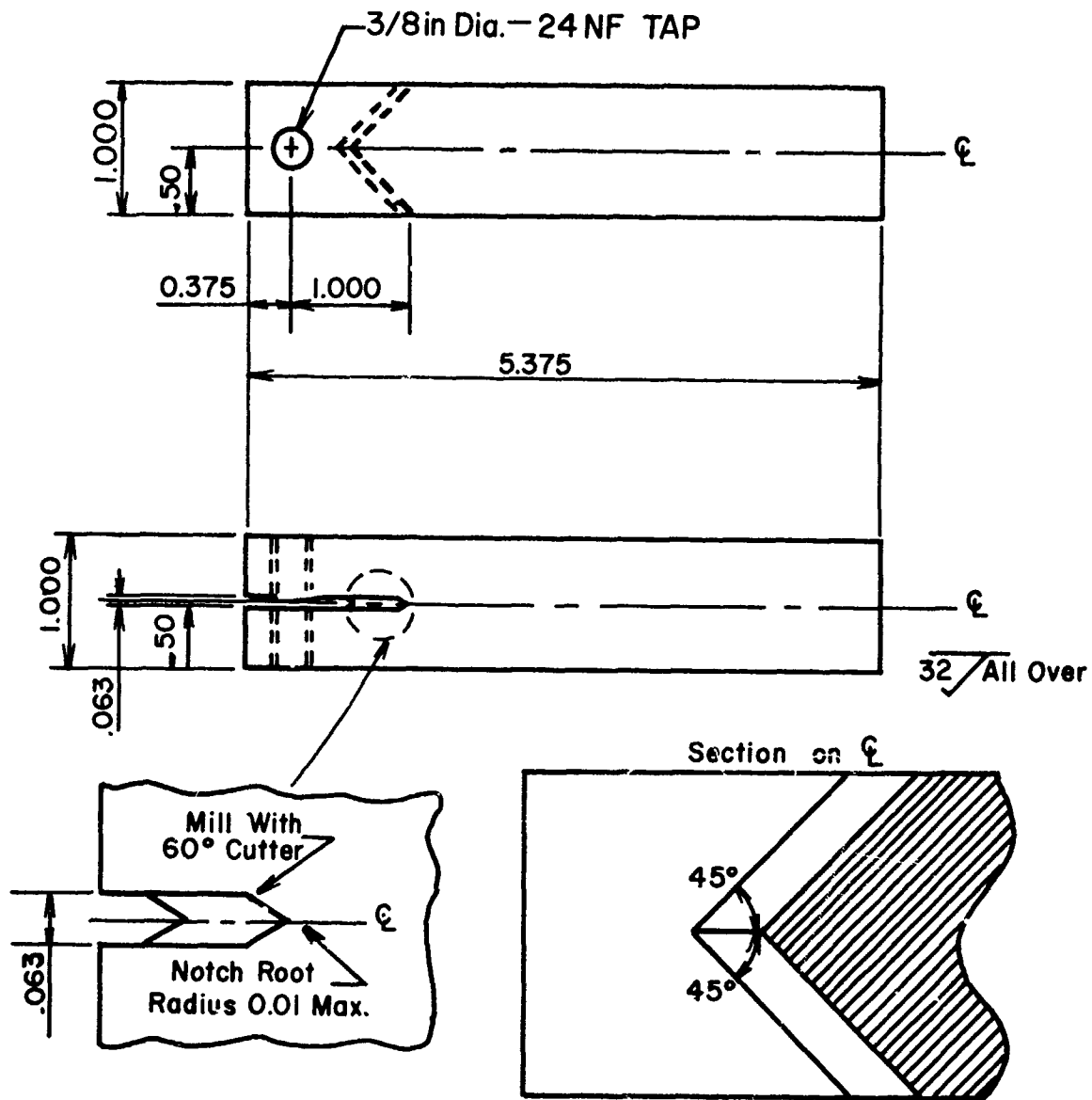

Fig. 13 Configuration of Double Cantilever Beam (DCB) Specimen Used for SCC Tests

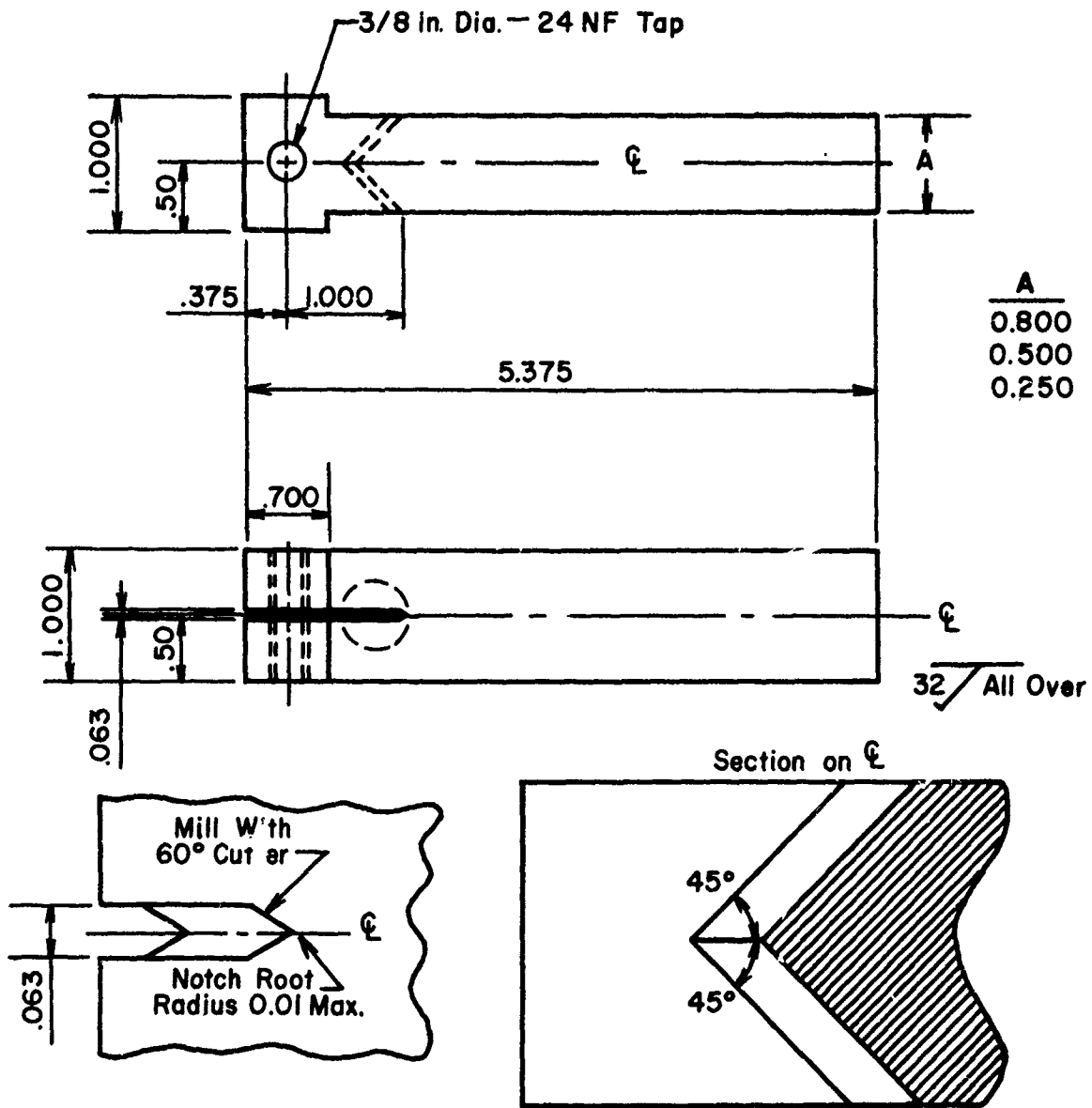

Fig. 14 Configuration of Reduced Thickness Double Cantilever Beam (DCB) Specimen Used for SCC Tests

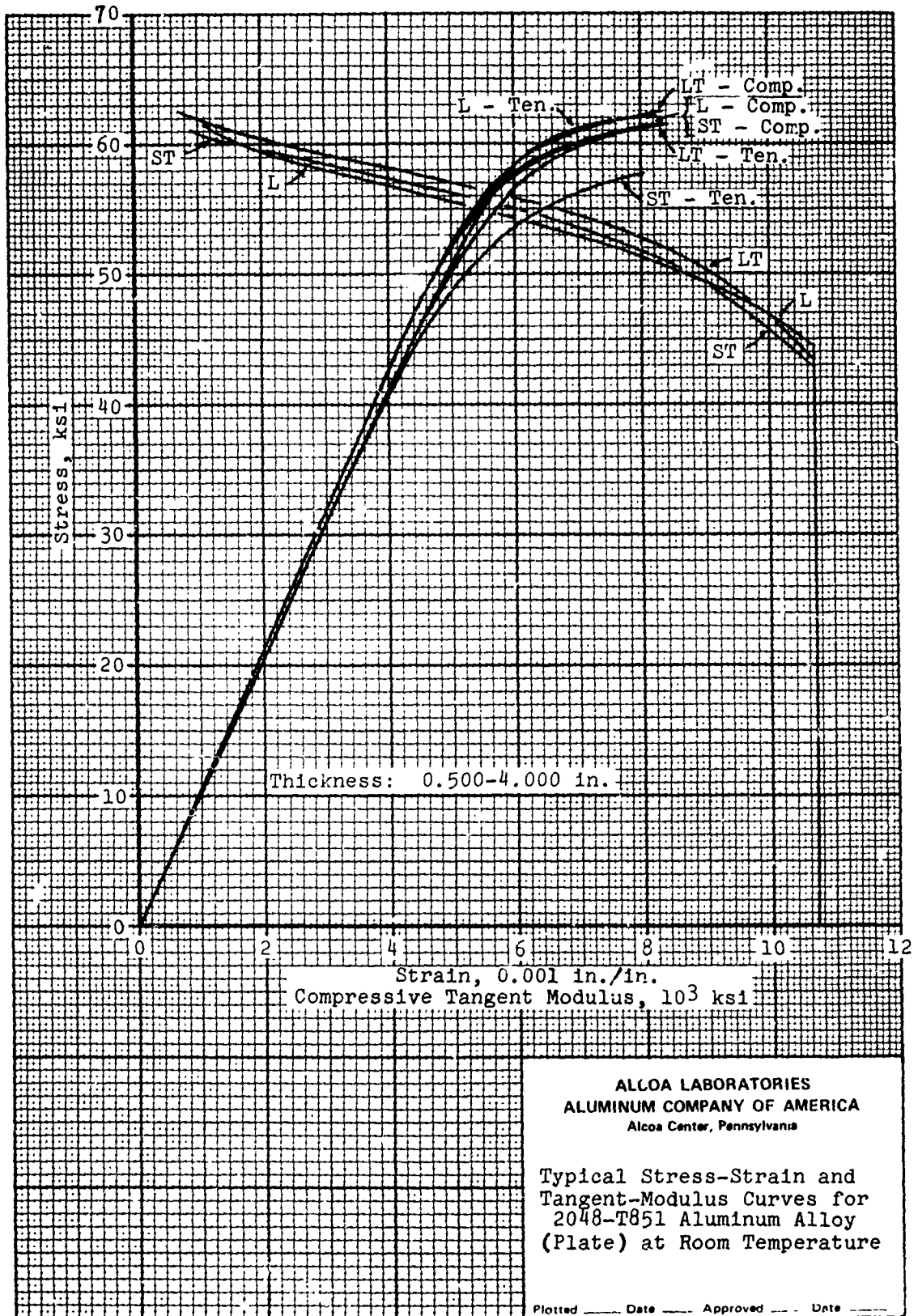

Fig. 15

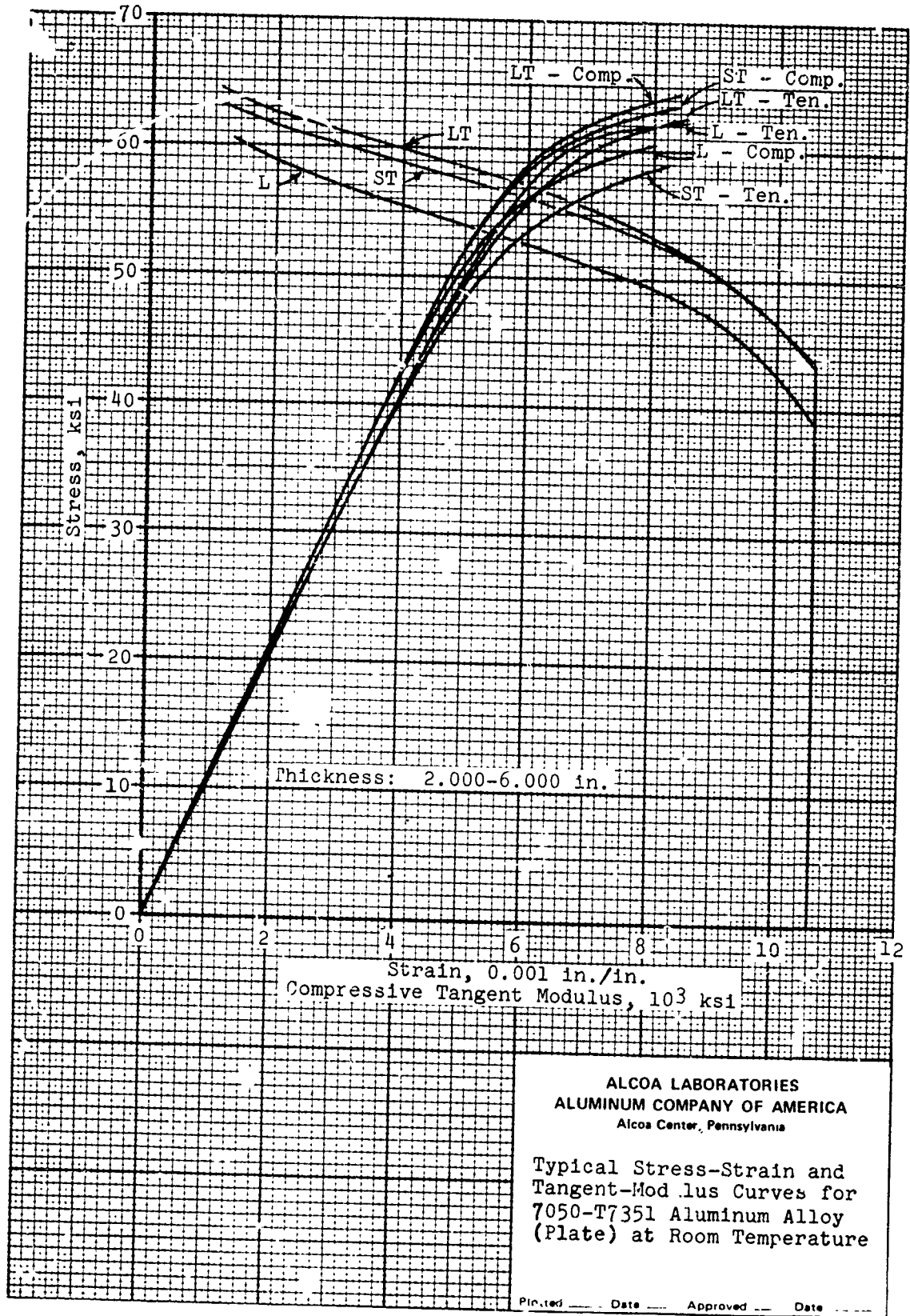

Fig. 16

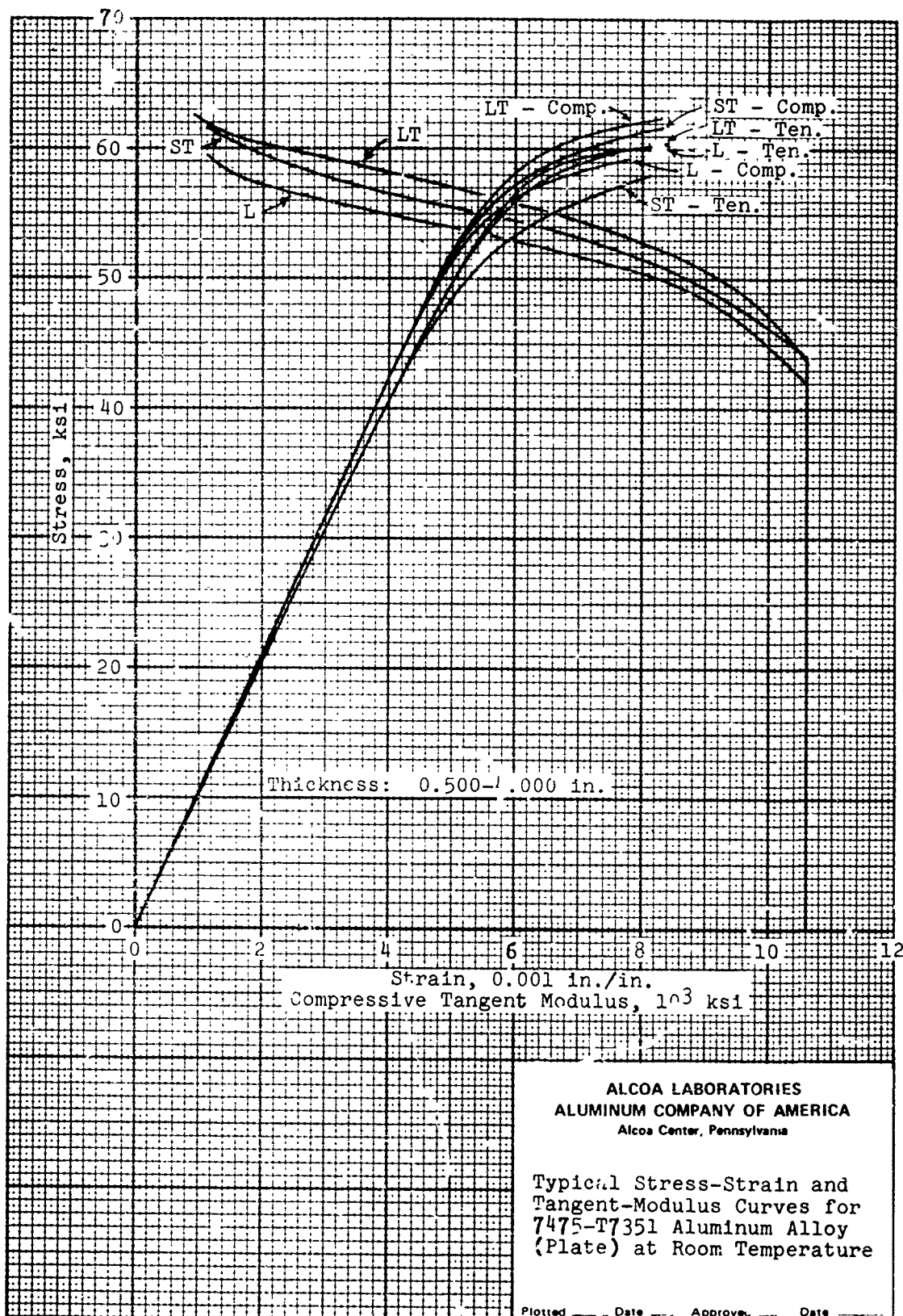

Fig. 17

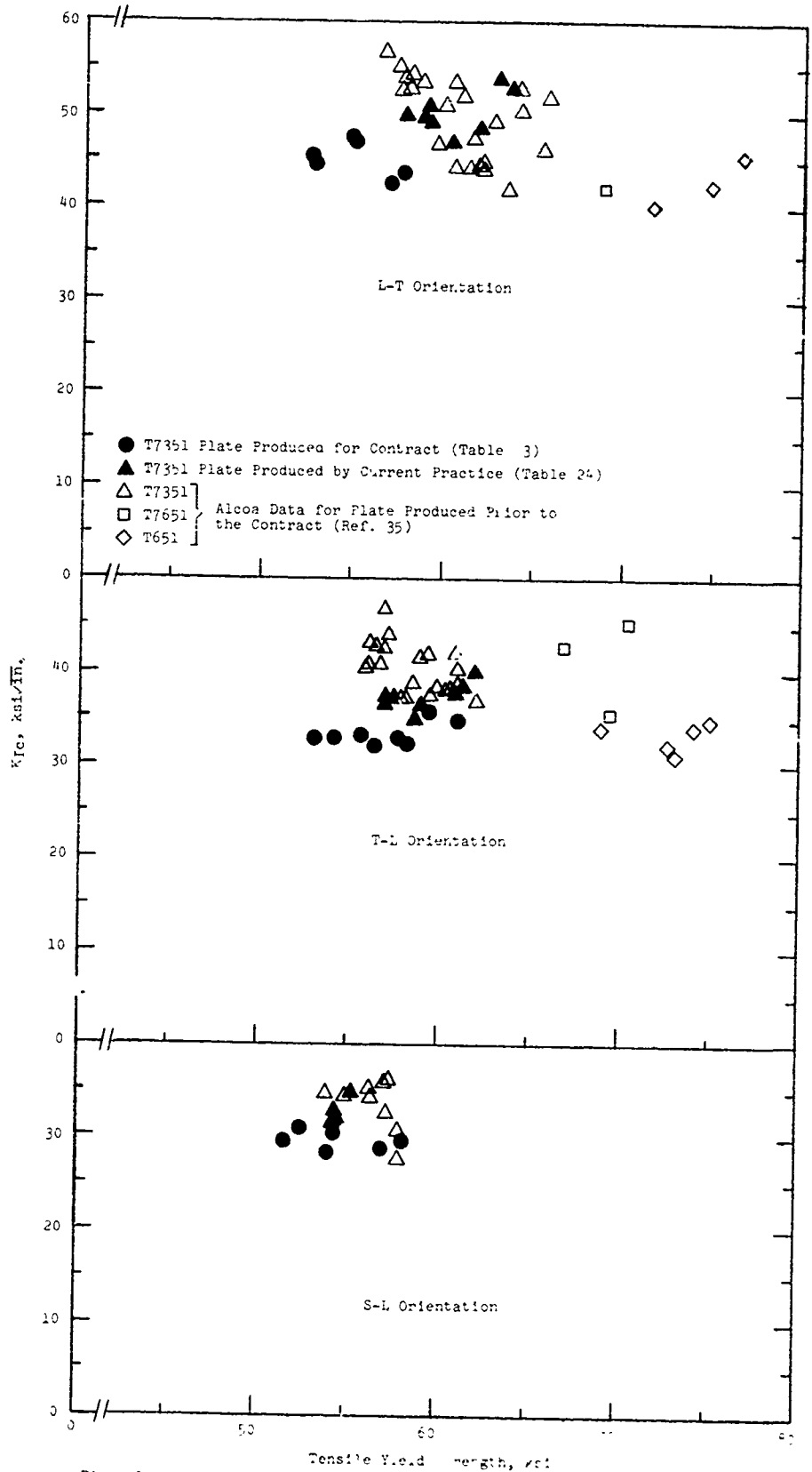

Fig 15 Tensile Yield Strength of 7471 Plate, L-T, T-L, S-L

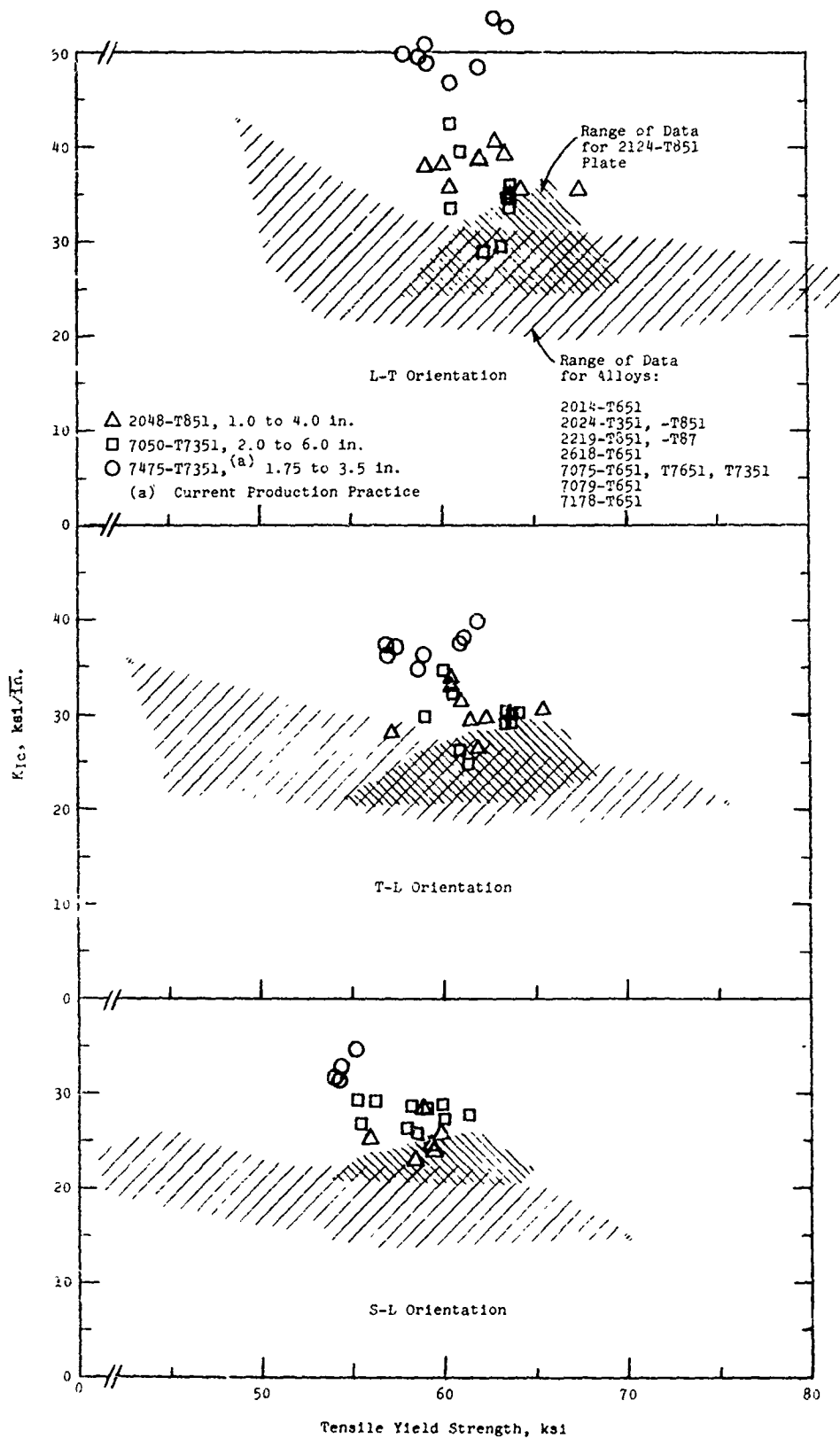

Fig. 19 K_{Ic} Vs Tensile Yield Strength of 2048-T851, 7050-T7351 and 7475-T7351 Plate

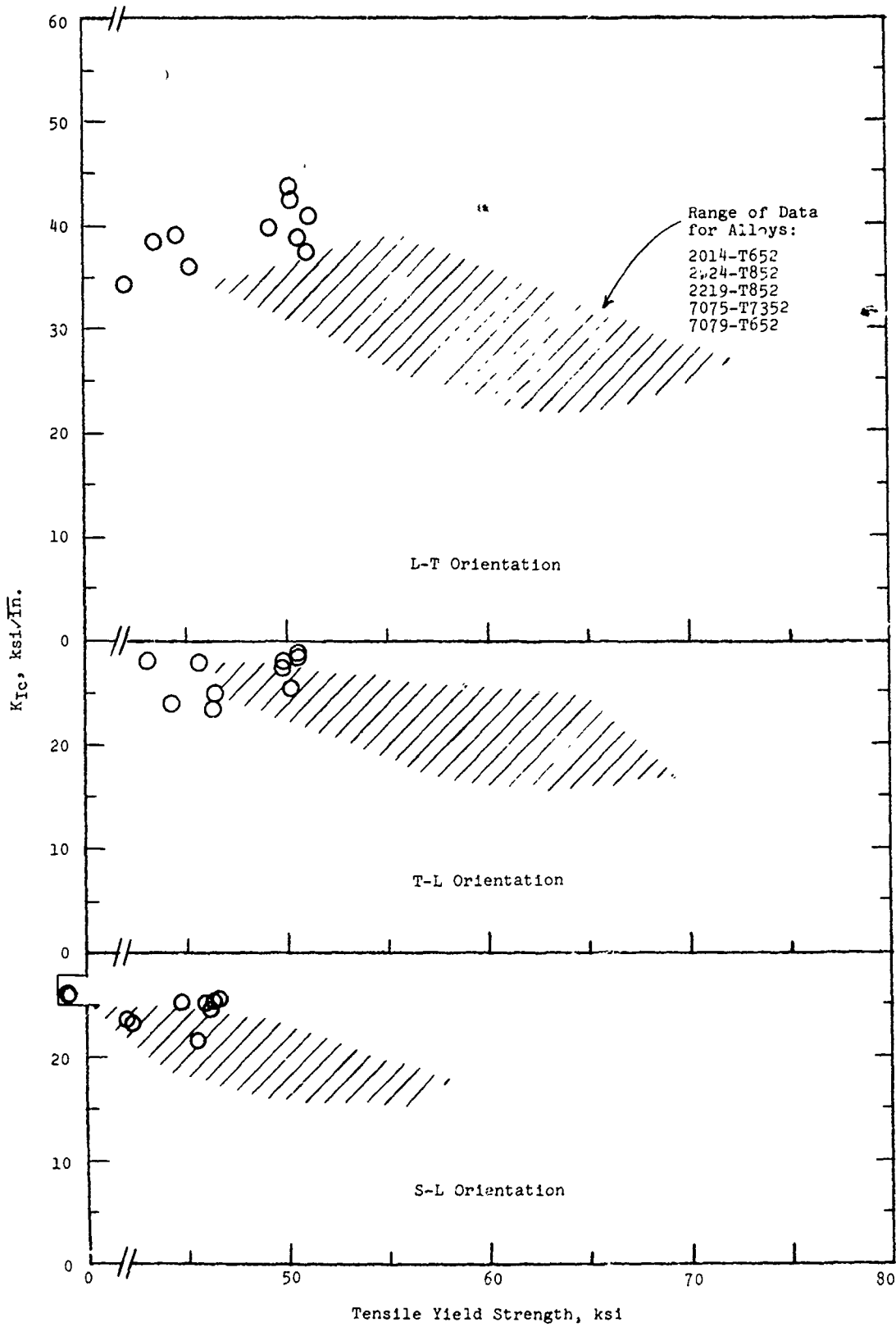

Fig. 20 K_{Ic} Vs Tensile Yield Strength of 2219-T852 Hand Forgings, 2.0 to 7.5-in. Thick

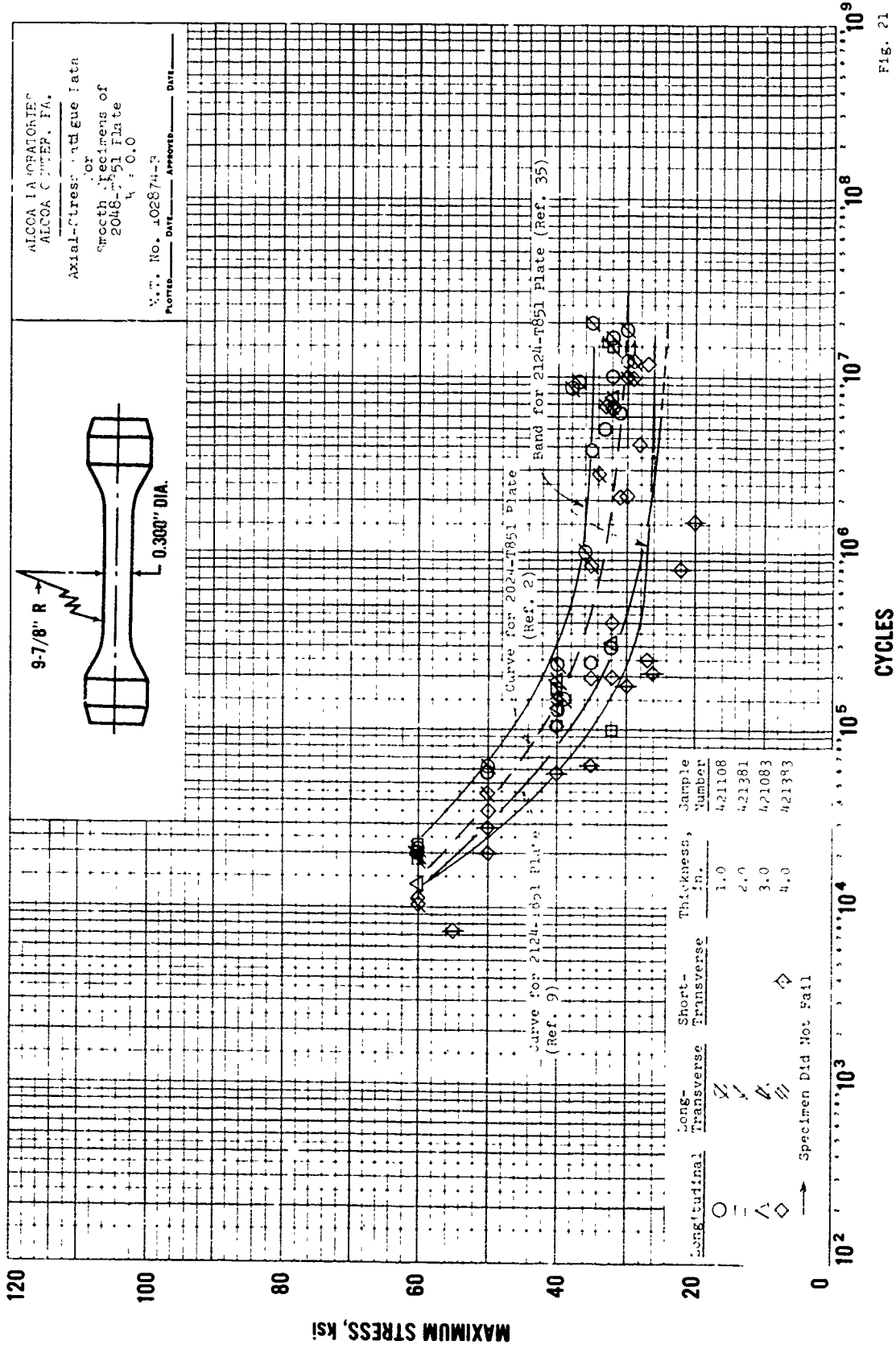

Fig. 21

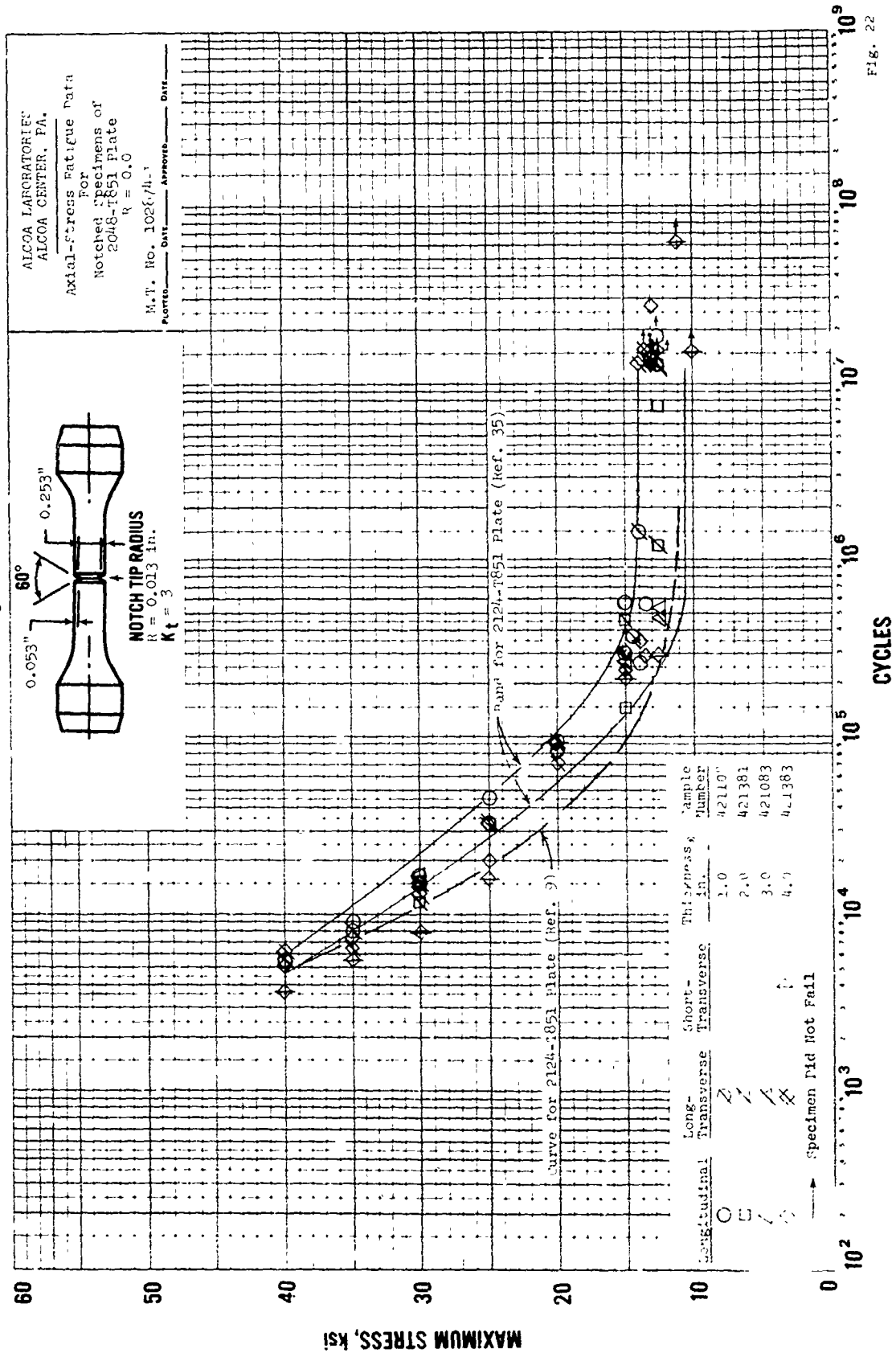

Fig. 22

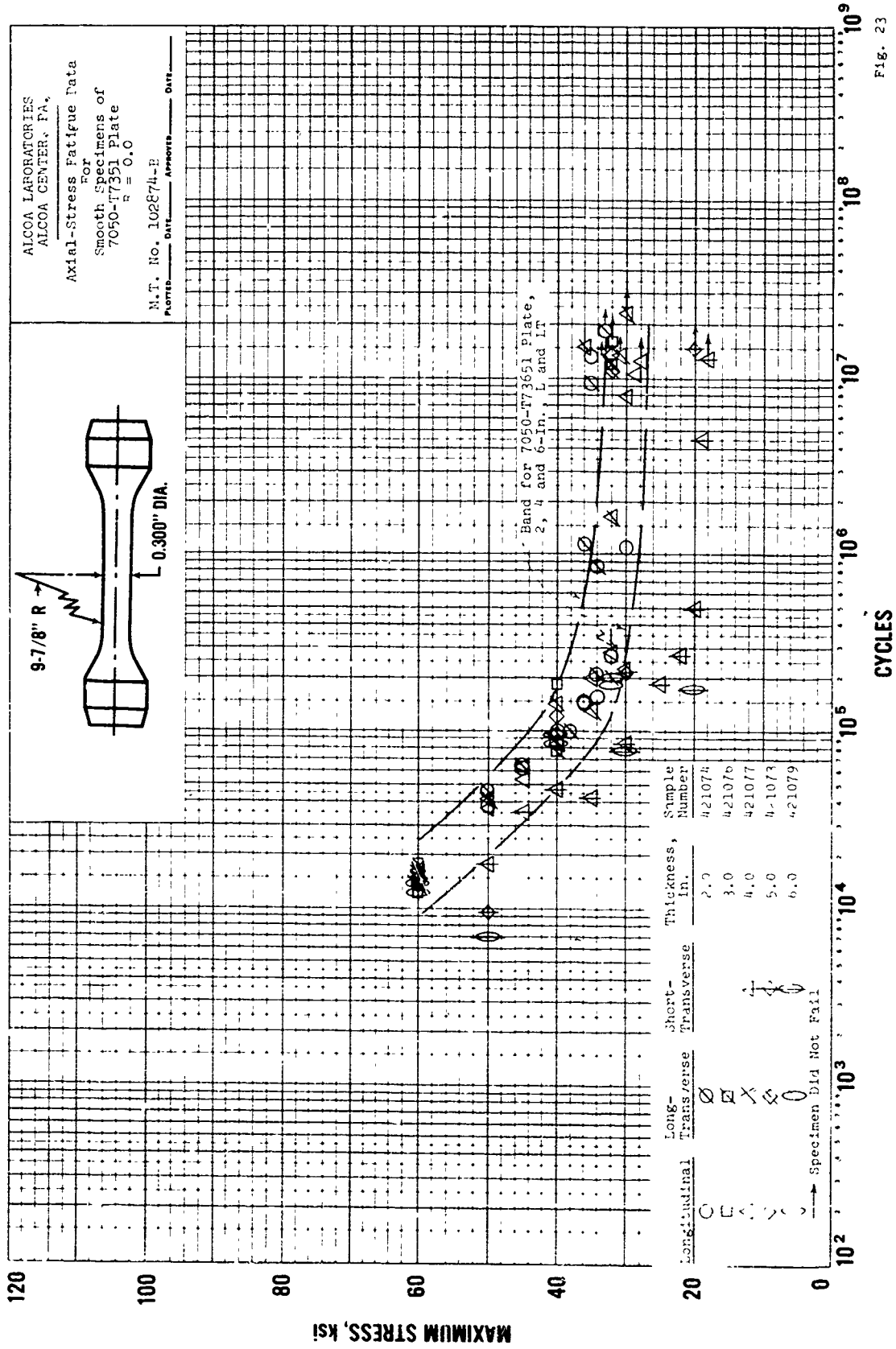

FIG. 23

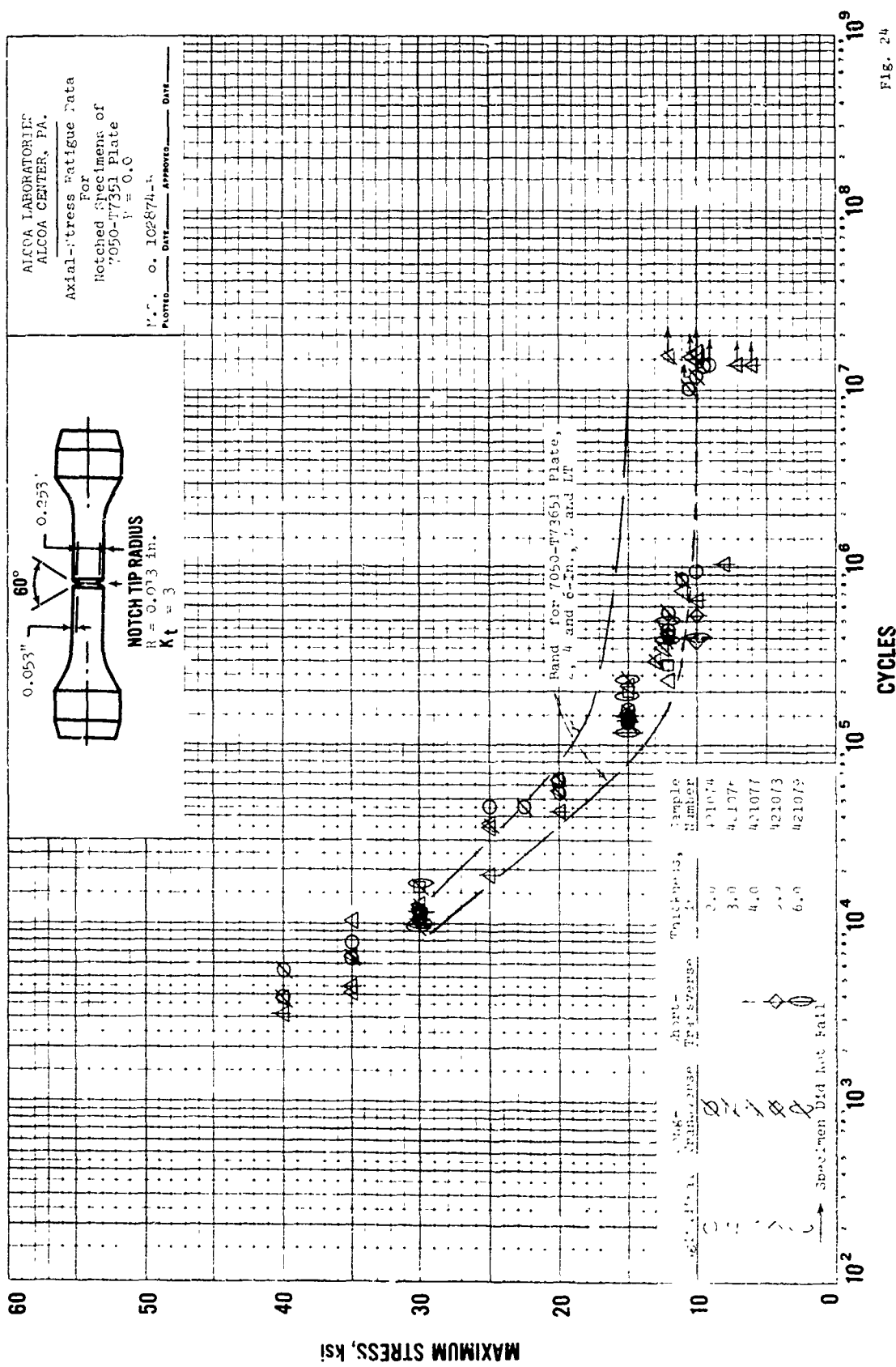

FIG. 24

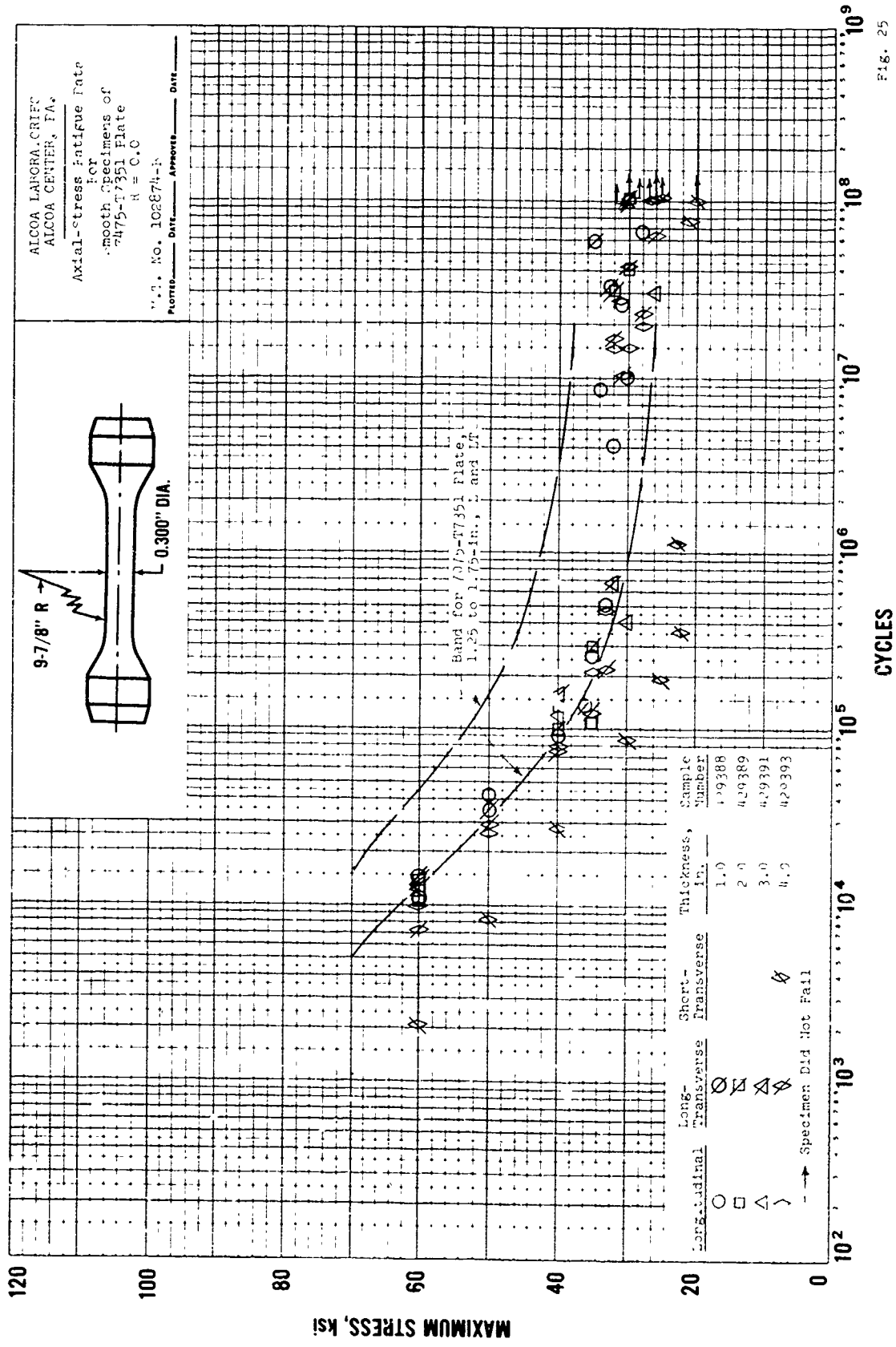

Fig. 25

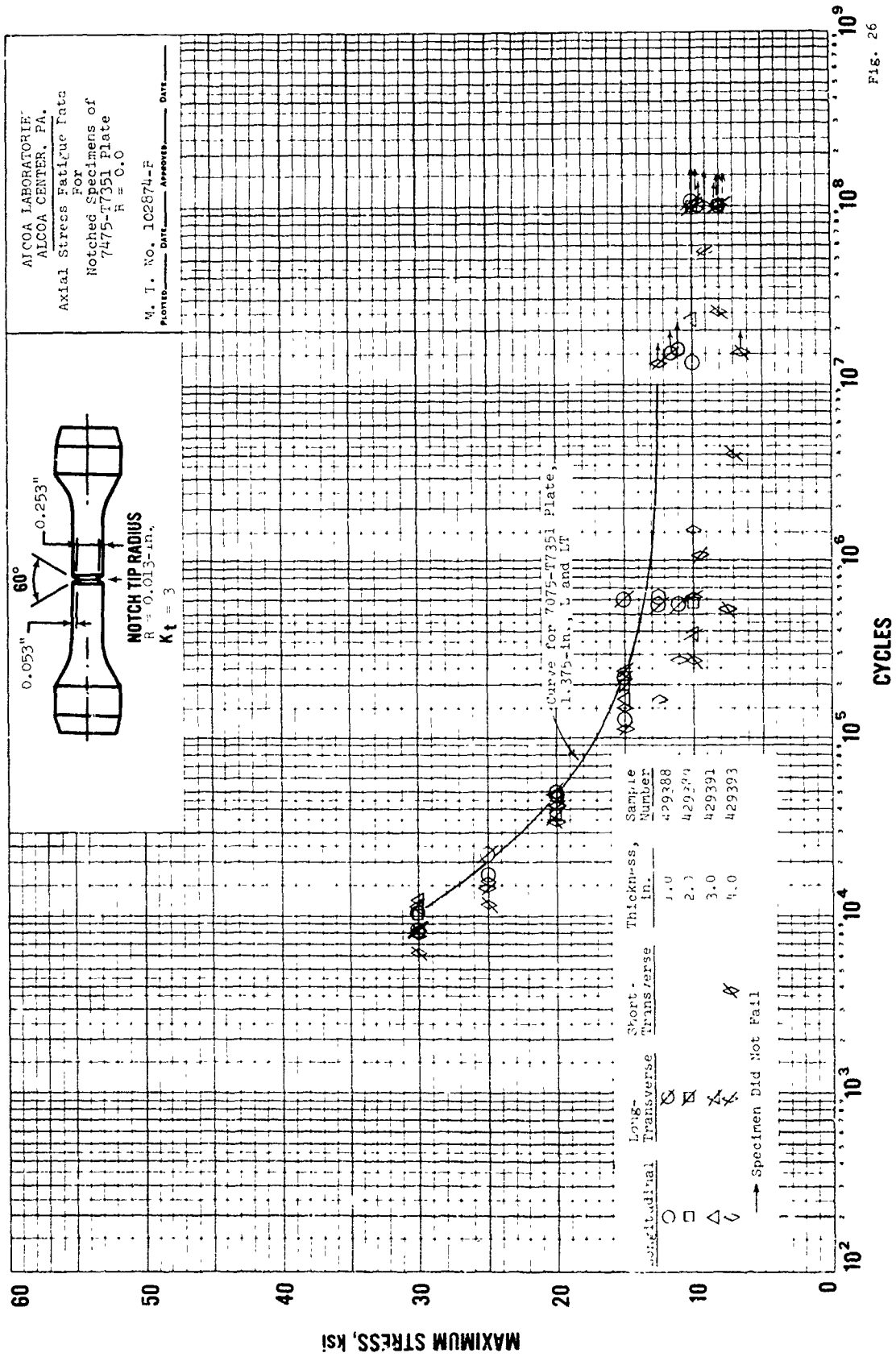

FIG. 26

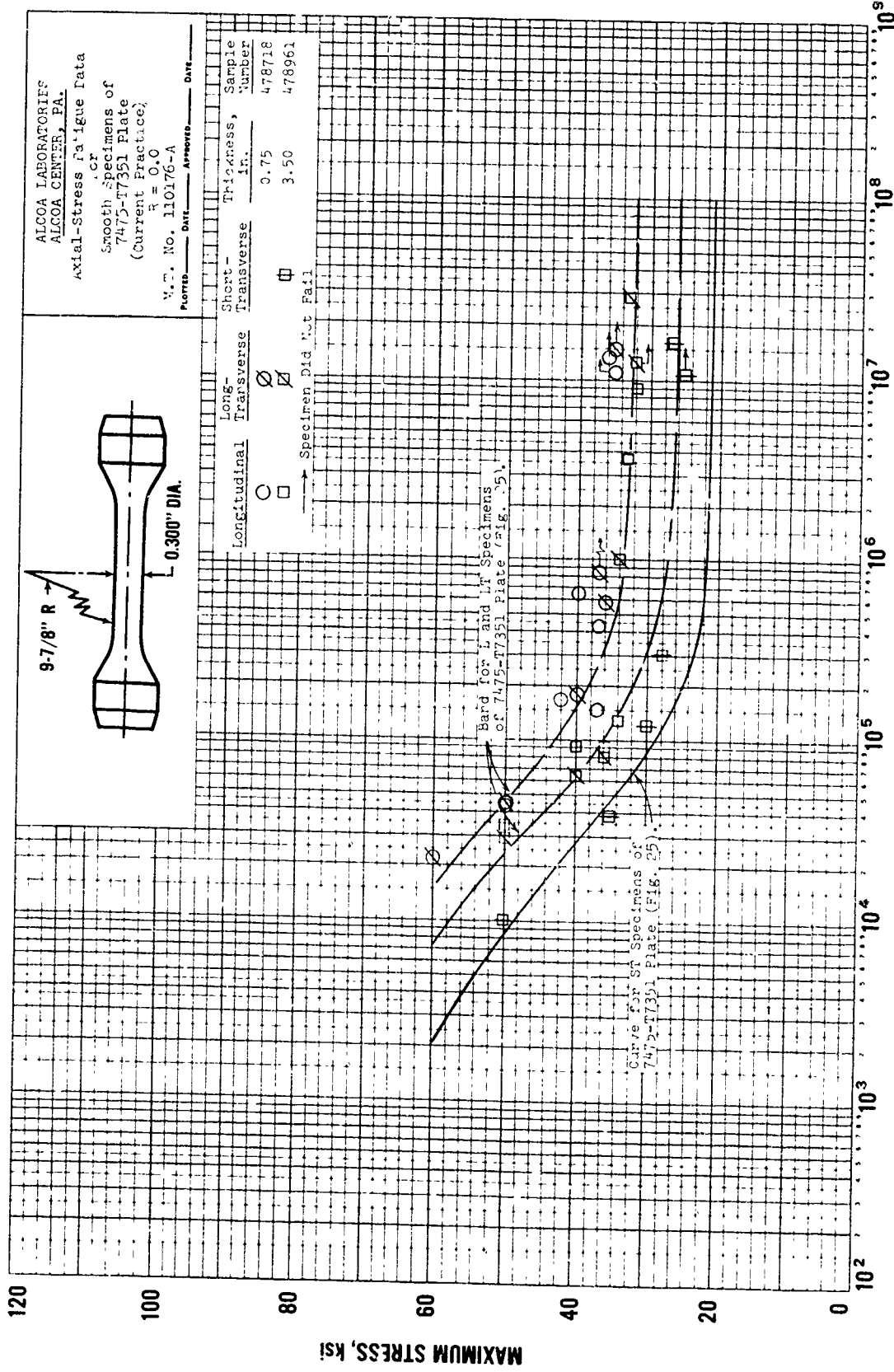

FIG. 27

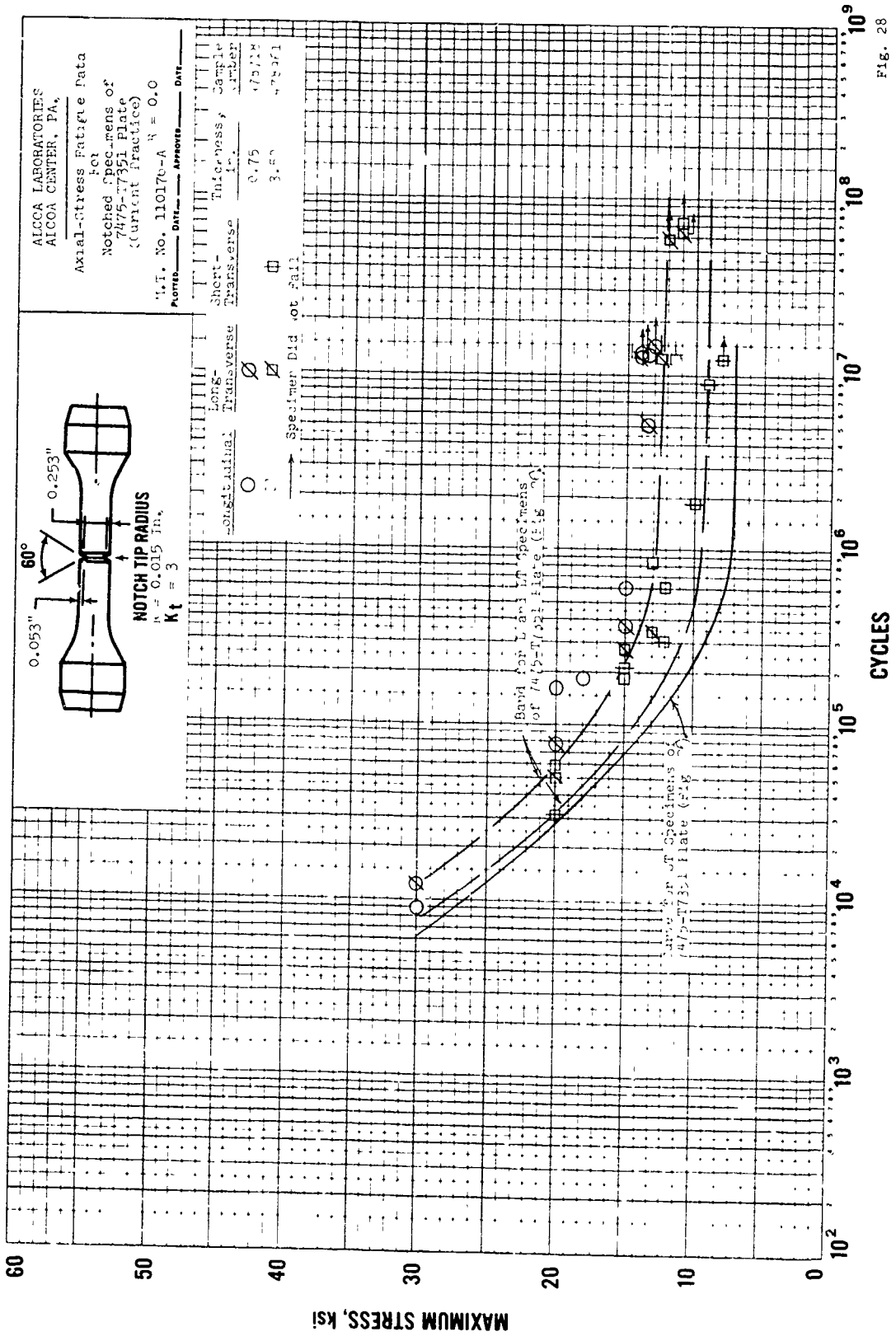

Fig. 28

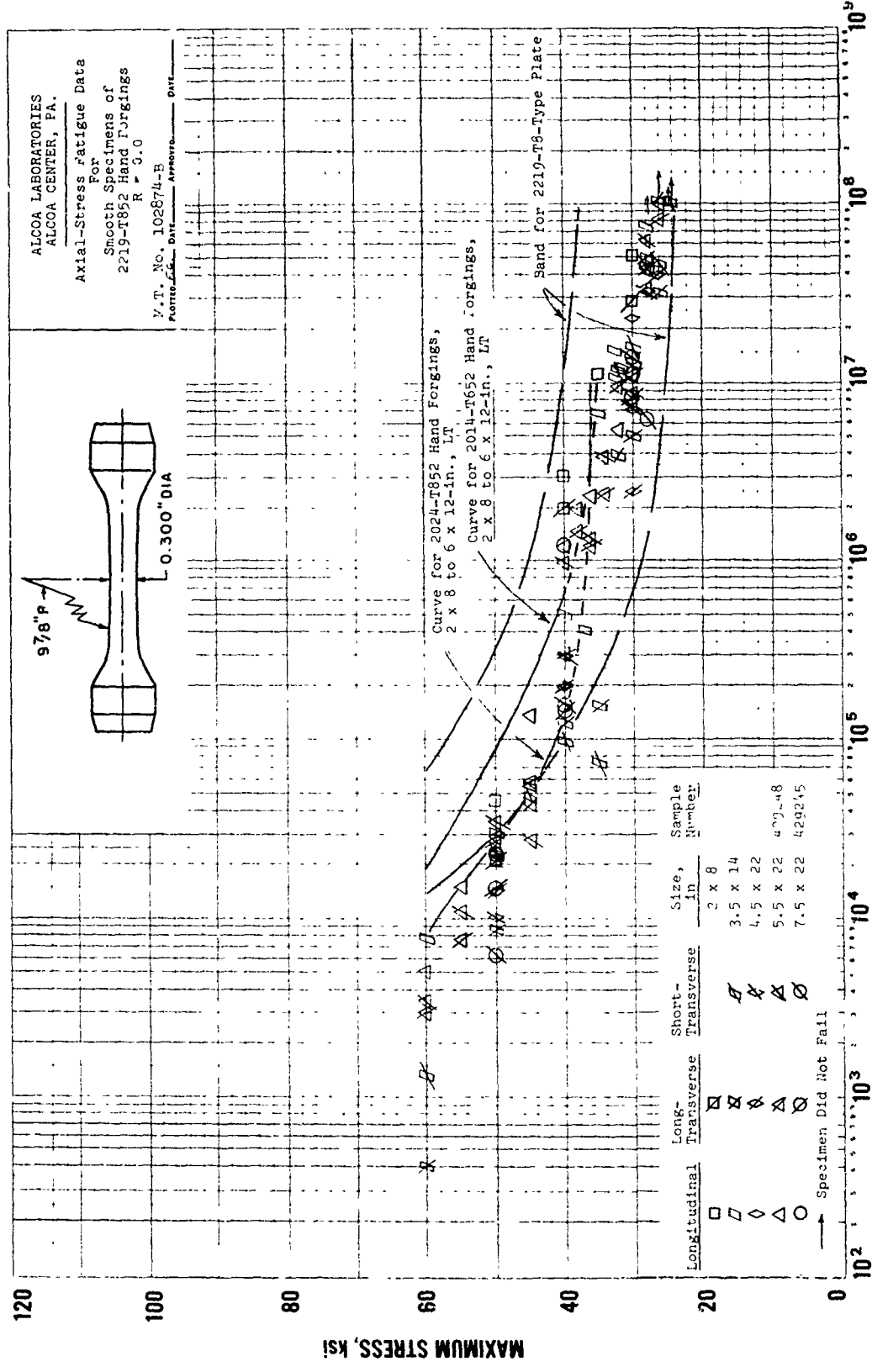

FIG. 29

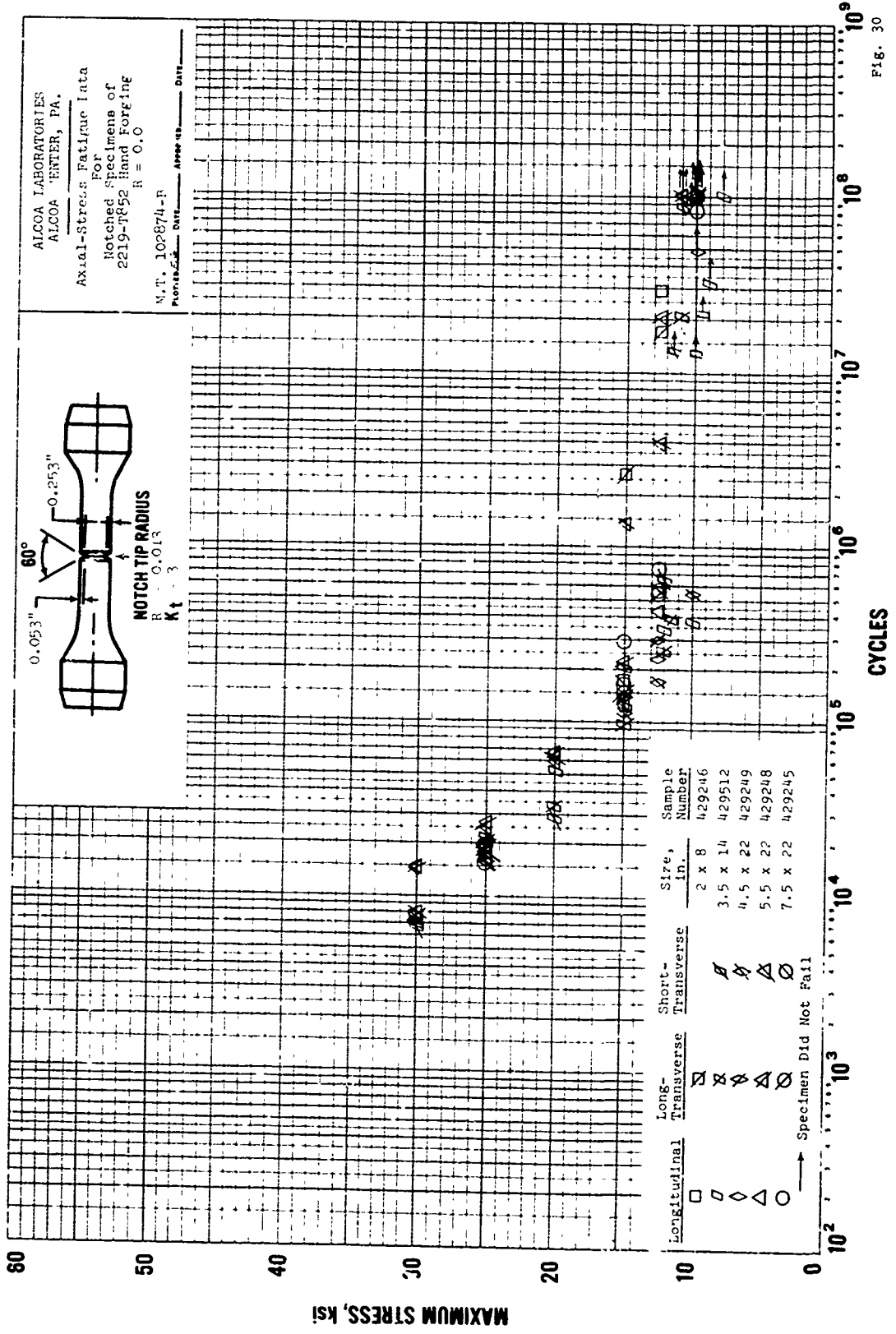

Fig. 30

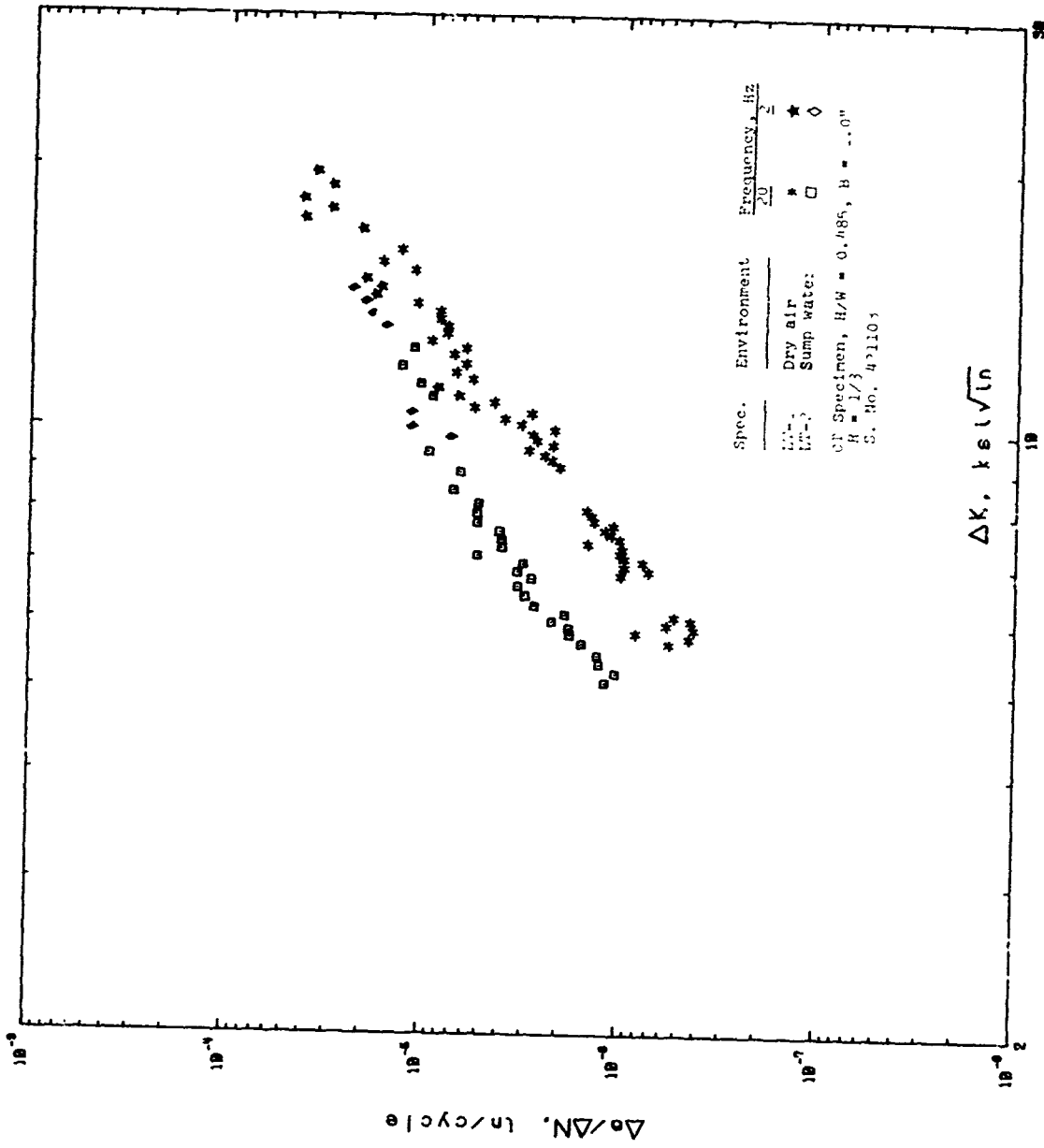

Fig. 31 Fatigue Crack Growth Data for 1-in. 2048-T851 Plate
 L-f Orientation

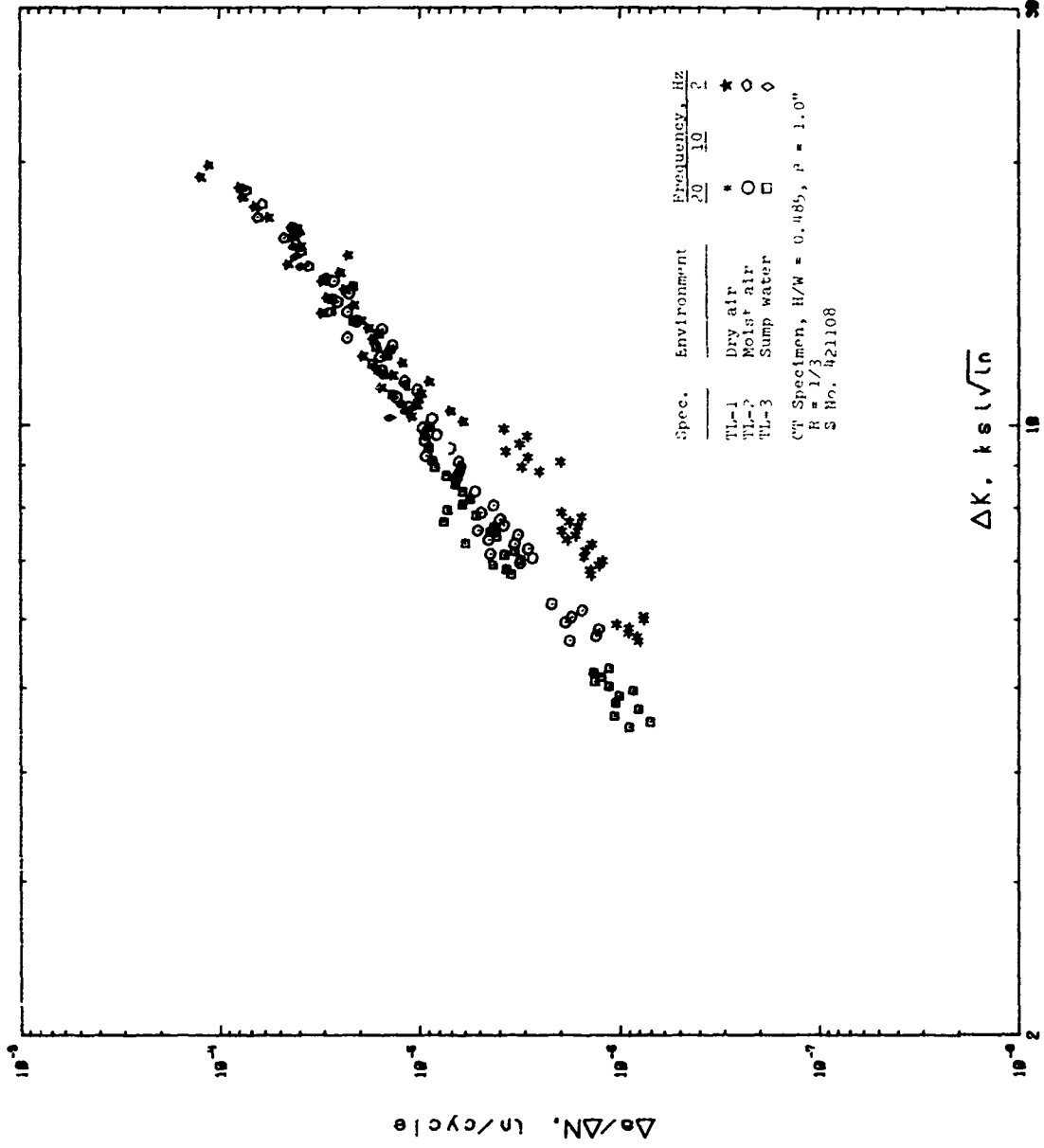

Fig. 32 Fatigue Crack-Growth Data for 1-in. 2048-T851 Plate
T-L Orientation

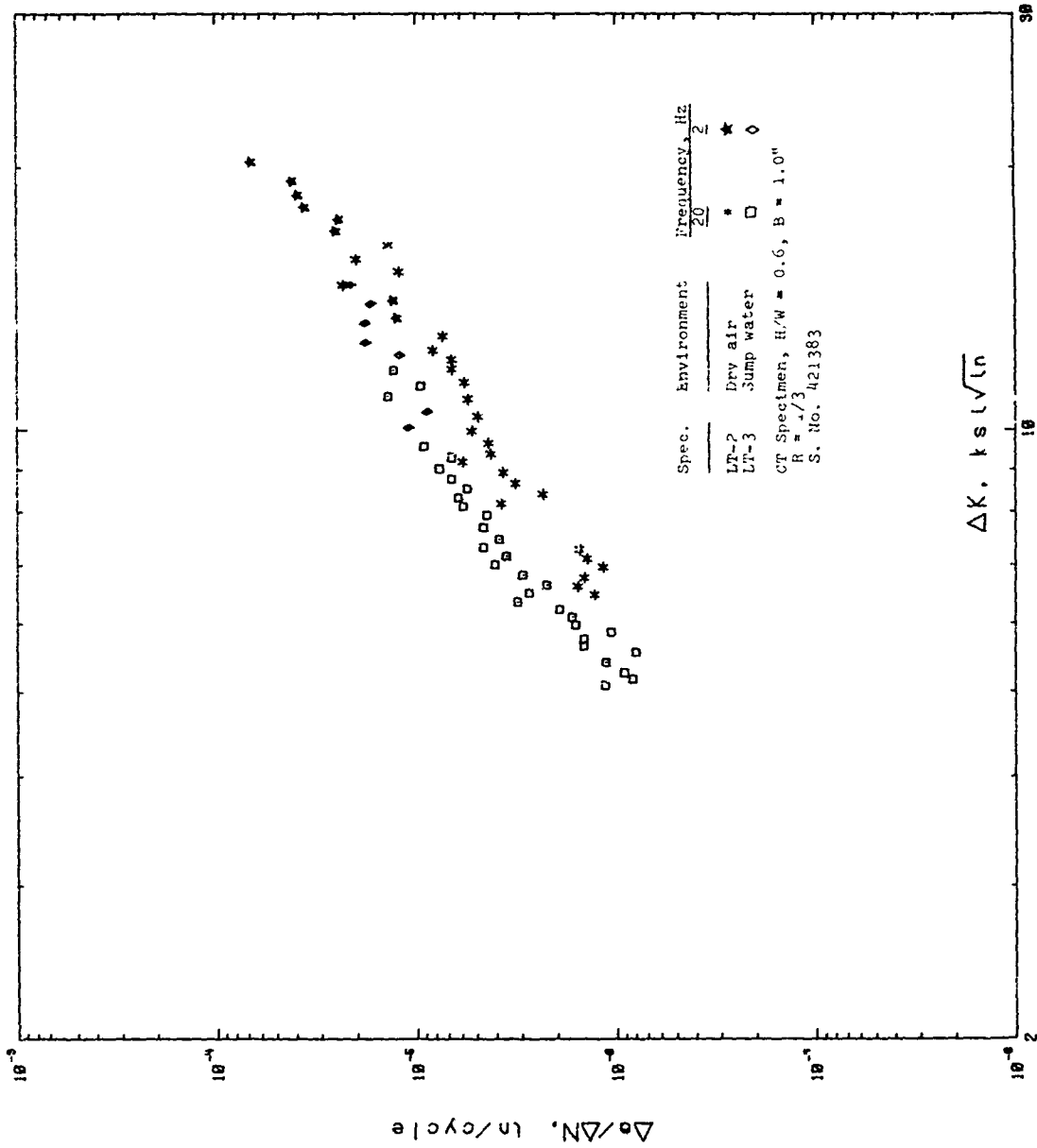

Fig. 33 Fatigue Crack-Growth Data for 1/4-in. 2048-T851 Plate
L-T Orientation

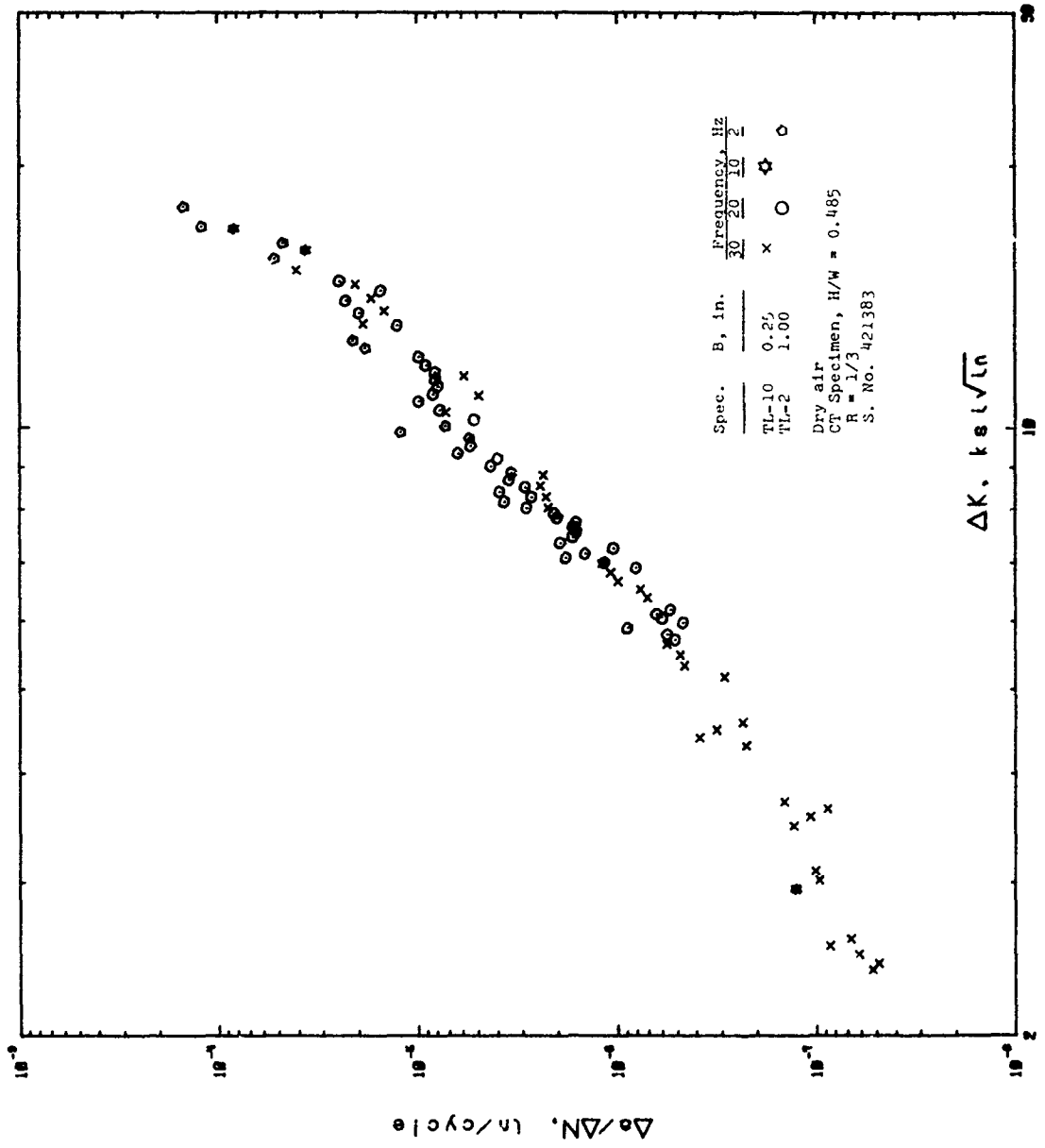

Fig. 34 Fatigue Crack-Growth Data for 1/4 in. 2048-T851 Plate
T-L Orientation (dry air)

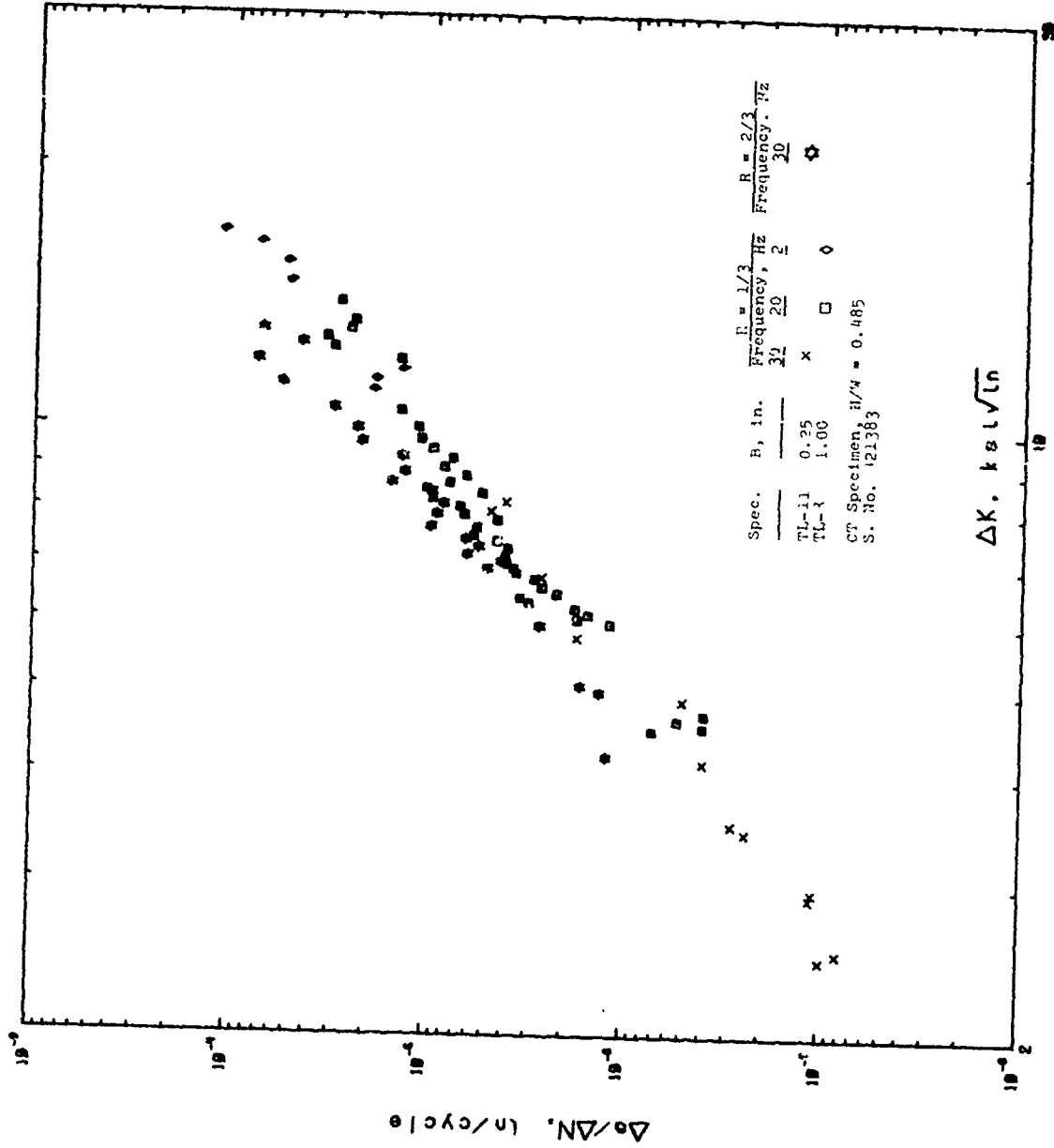

Fig. 35 Fatigue Crack-Growth Data for 4-in. 2024-T851 Plate
T-L Orientation (seawater)

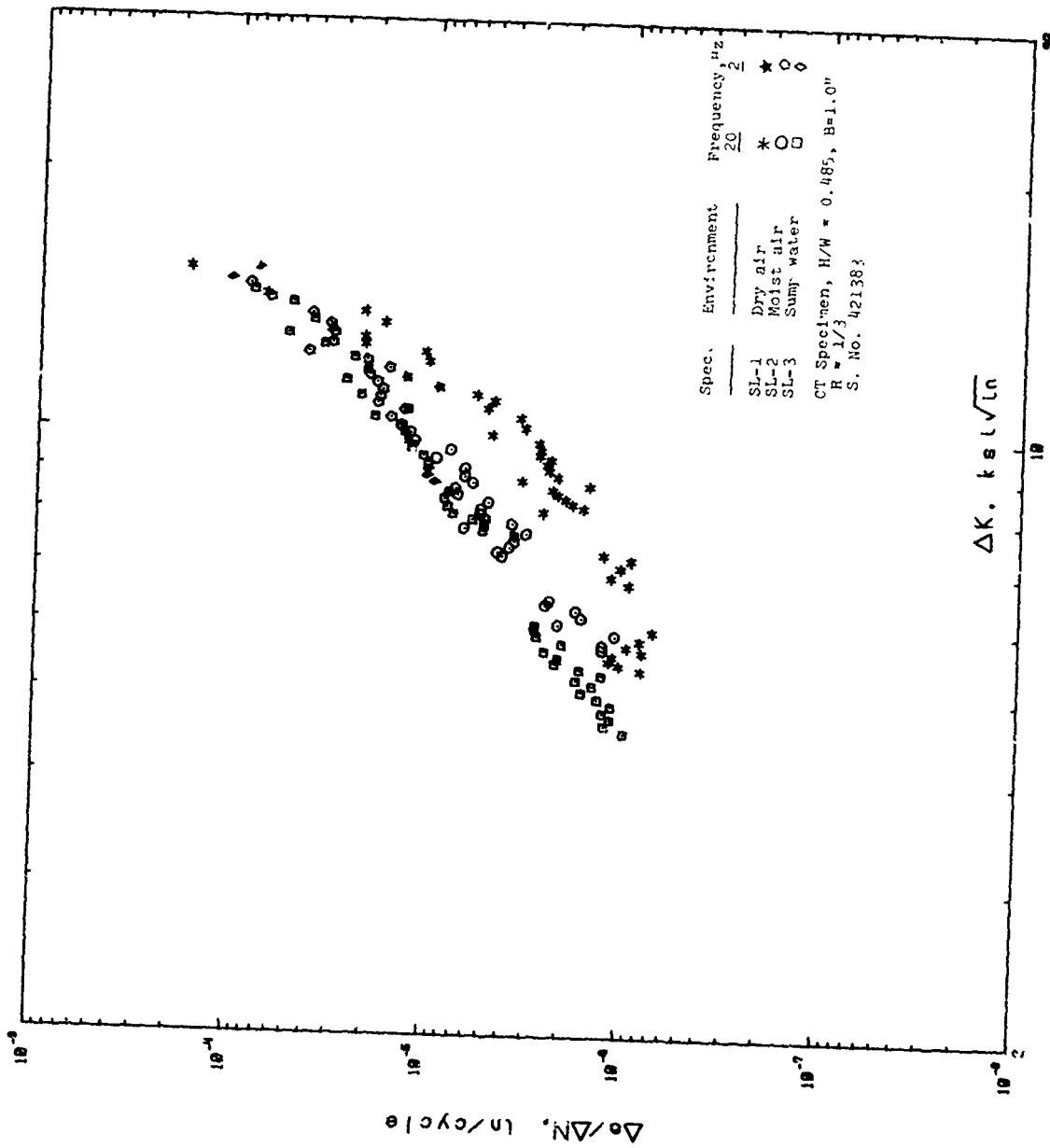

Fig. 36 Fatigue Crack-growth Data for 1/4-in. 2043-T851 Plate
S-L Orientation

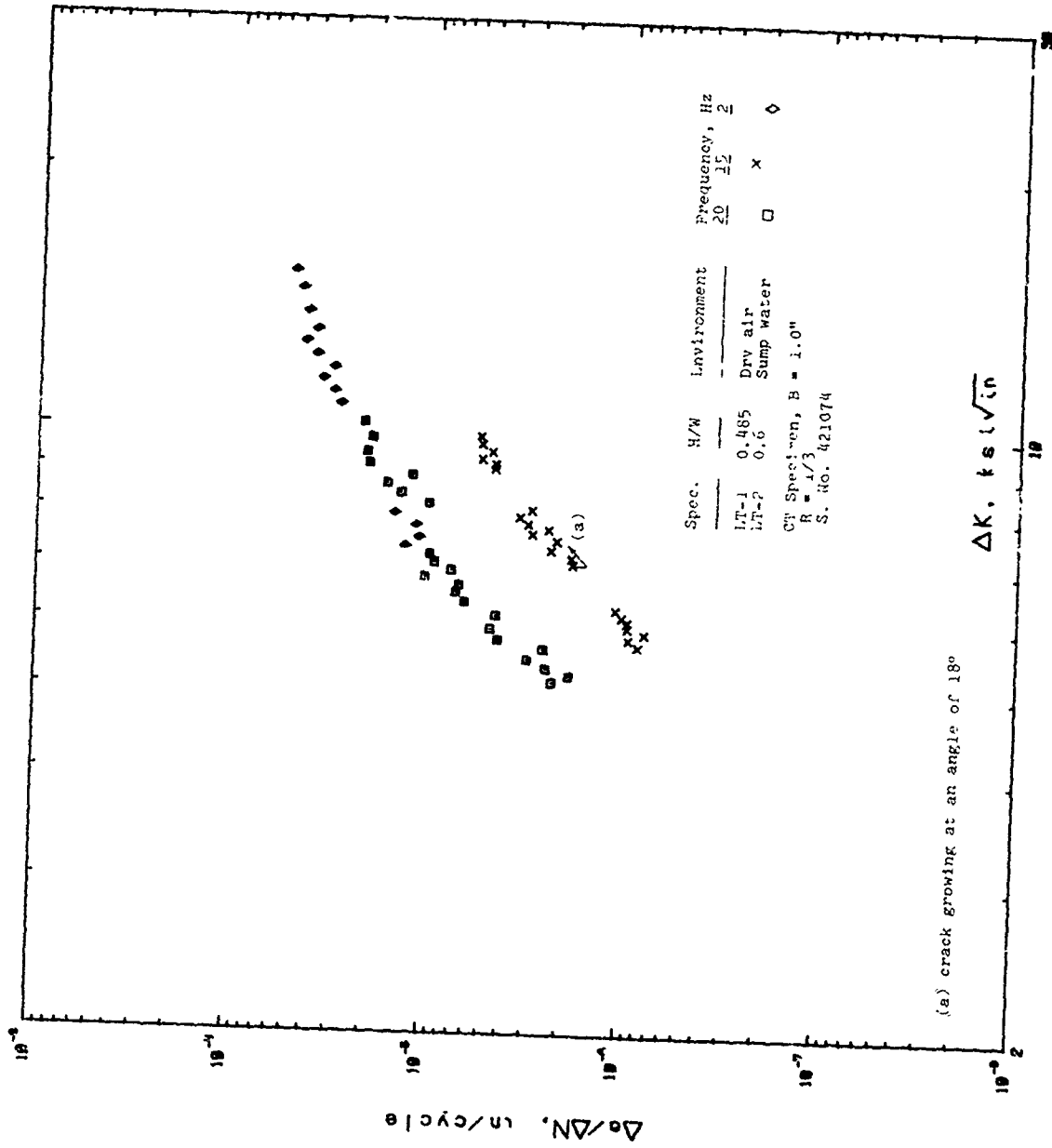

FIG. 37 Fatigue Crack-Growth Data for 2-in. 7050-T7351 Plate
 L-T Orientation

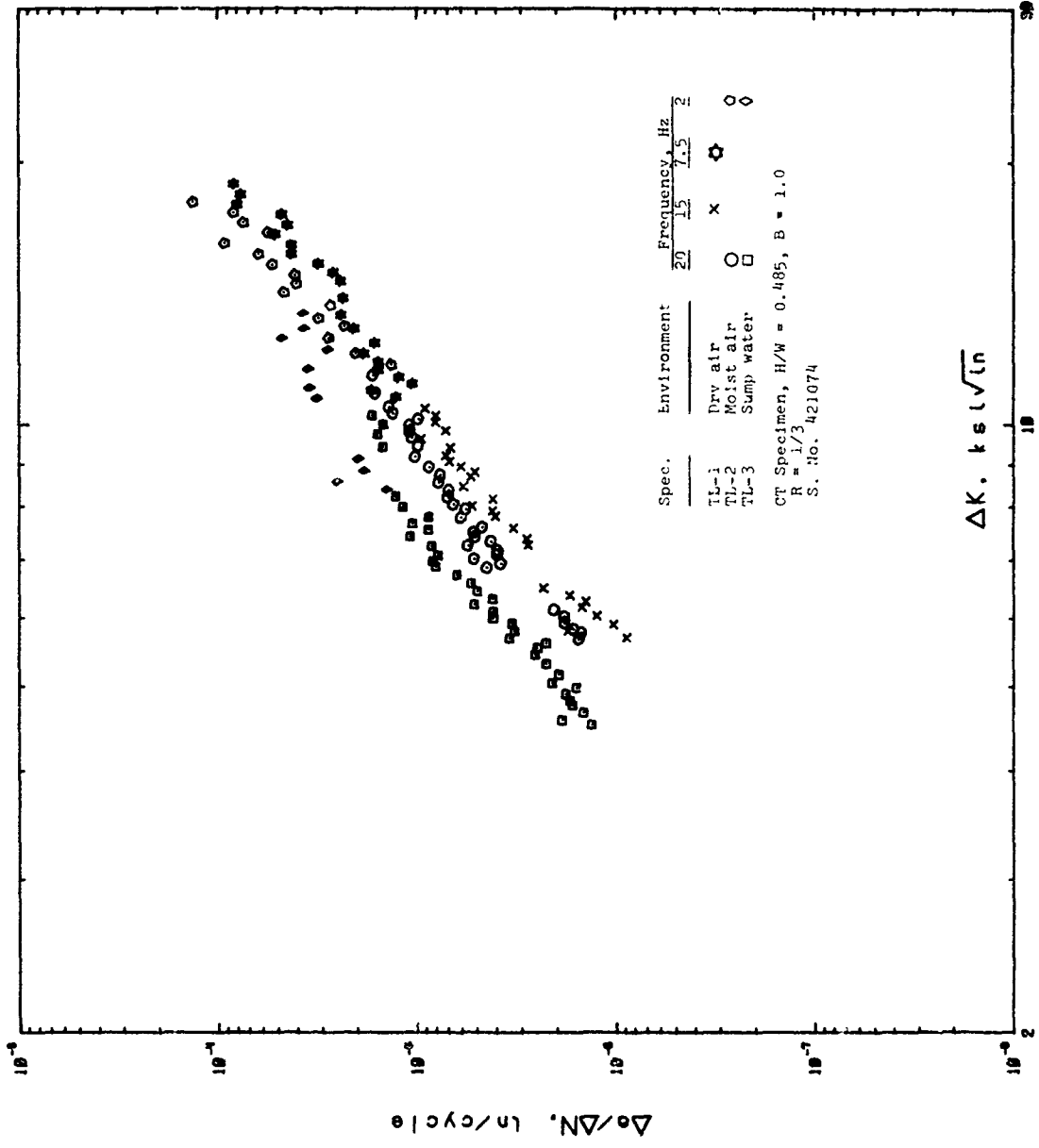

Fig. 38 Fatigue Crack-Growth Data for 2-in. 7050-T7351 plate
T-L Orientation

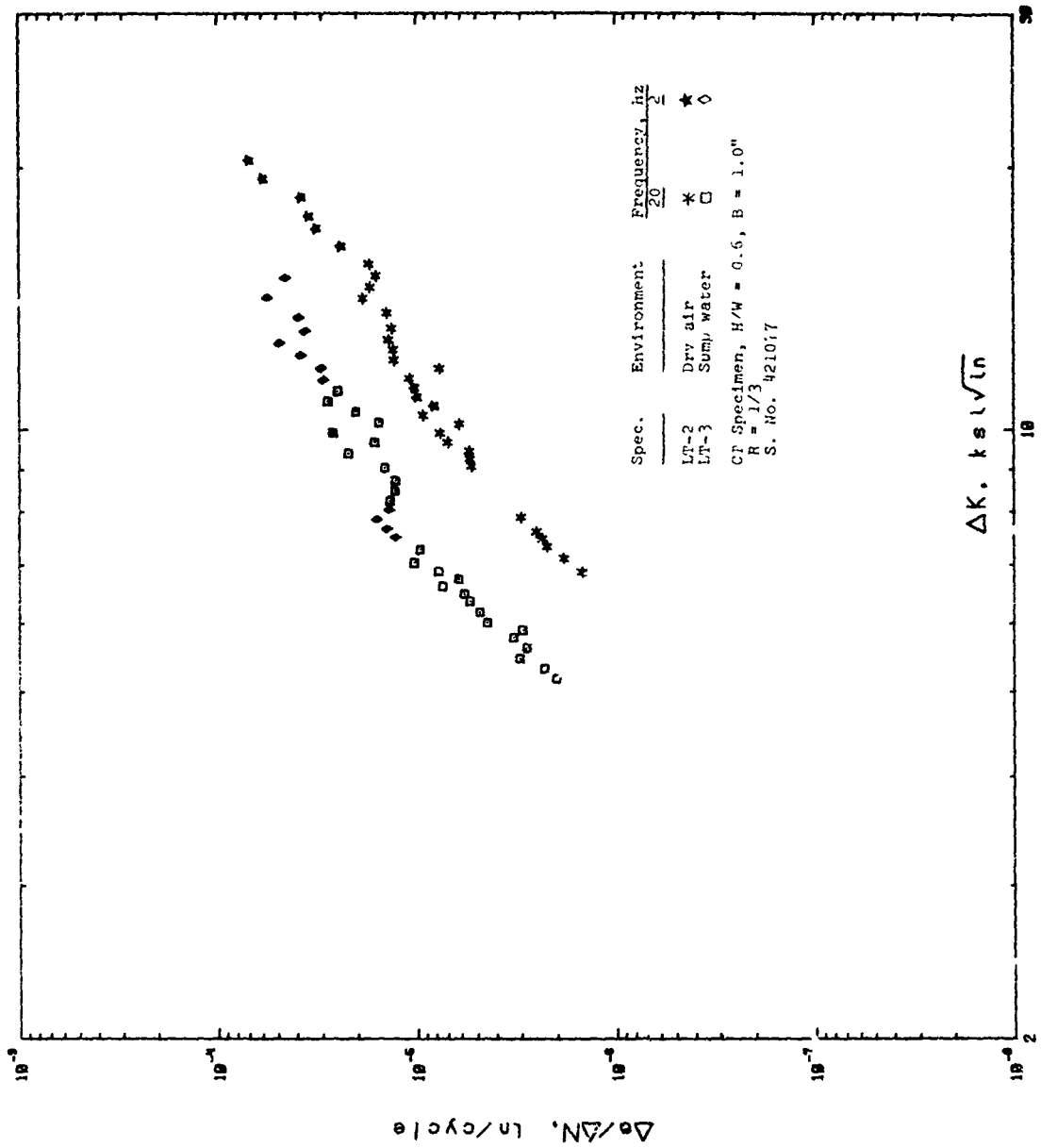

Fig. 39 Fatigue Crack-growth Data for 4-in. 7050-T7 351 Plate
L-T Orientation

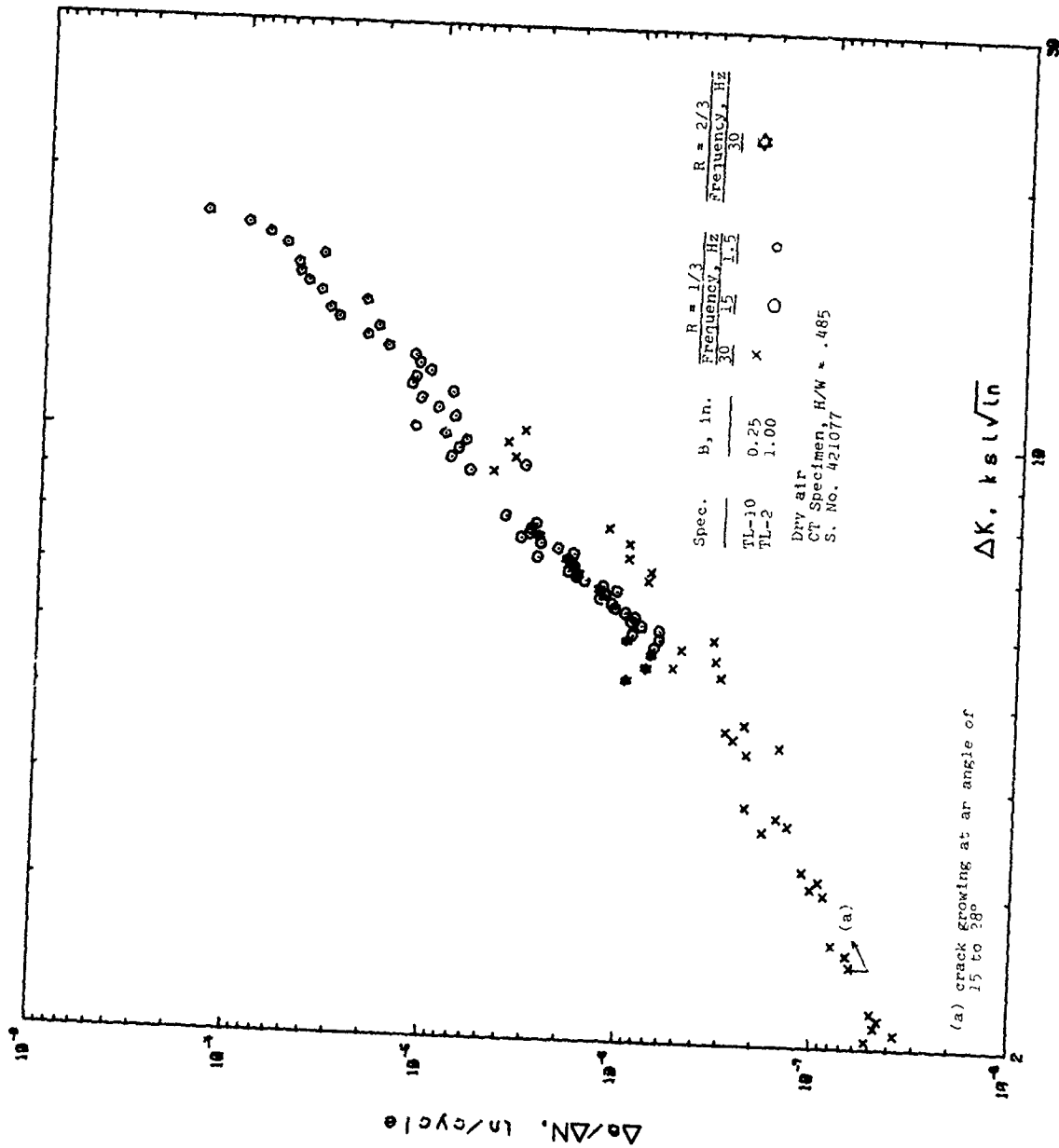

Fig. 40 Fatigue Crack-Growth Data for 4-in. 7050-T7351 Plate
T-L Orientation (dry air)

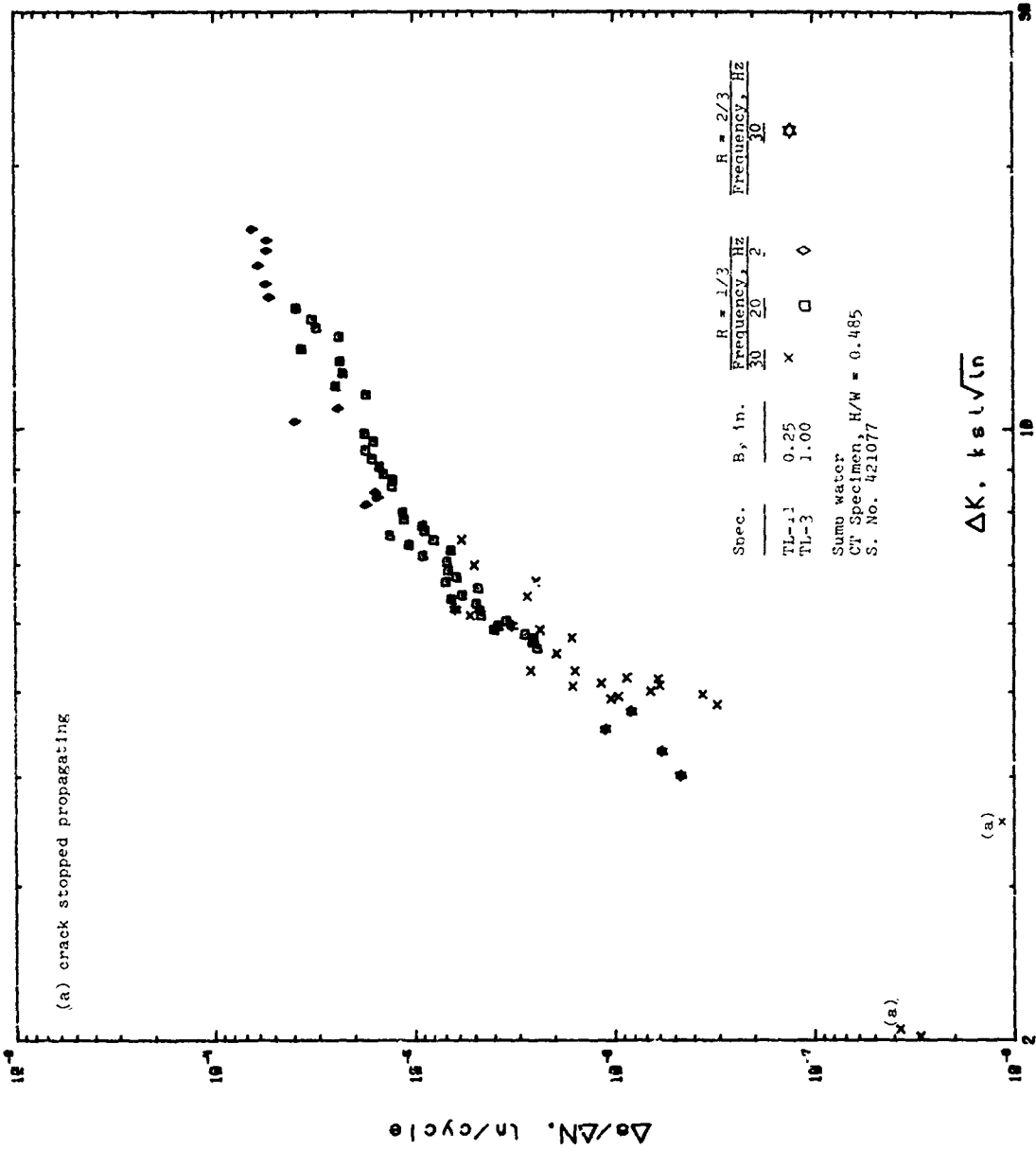

Fig. 41 Fatigue Crack-Growth Data for 4-in. 7050-T7351 Plate
T-L Orientation (sump water)

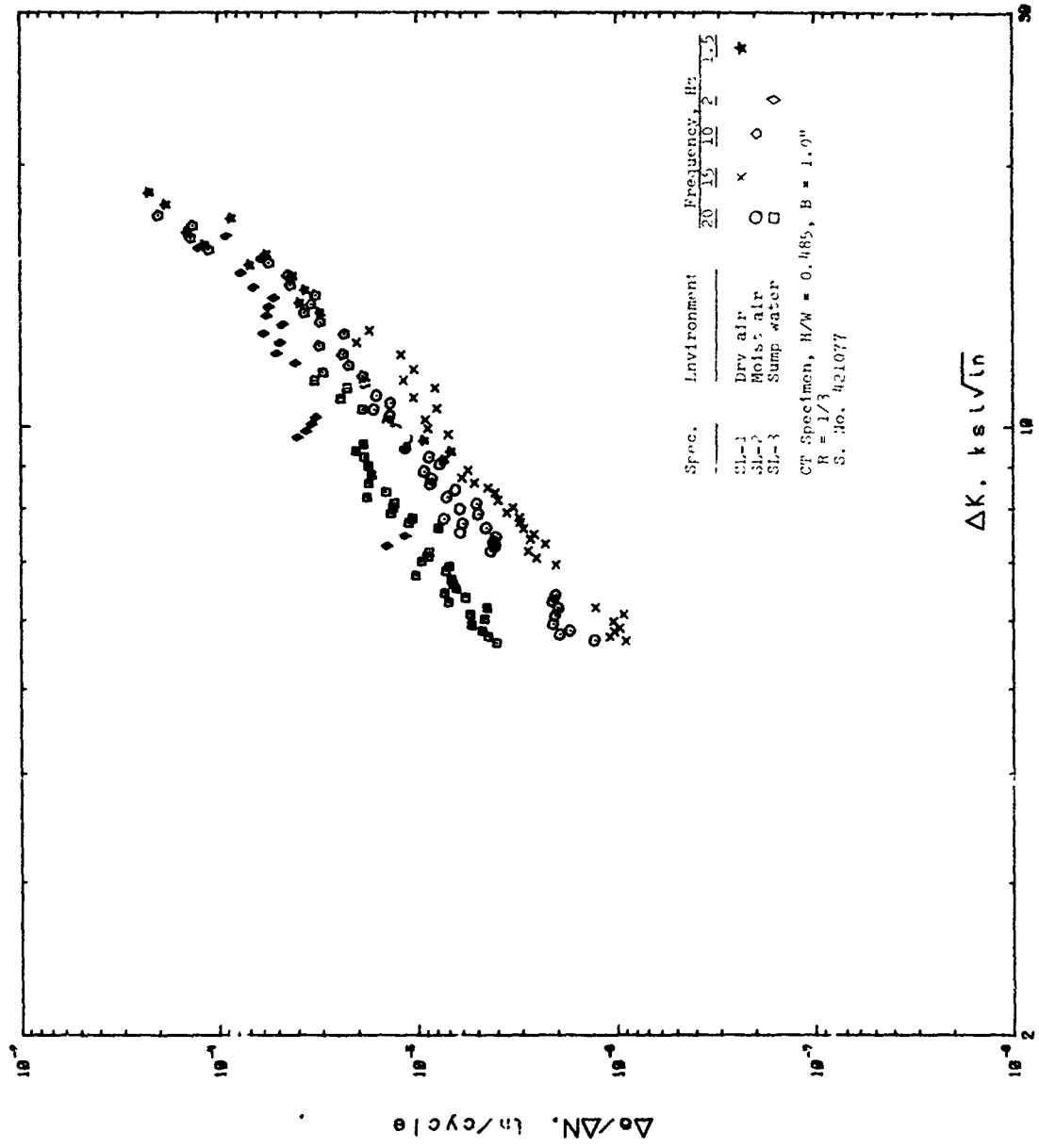

Fig. 42 Fatigue Crack-Growth Data for 4-in. 7050-T7351 Plate
 S-1 Orientation

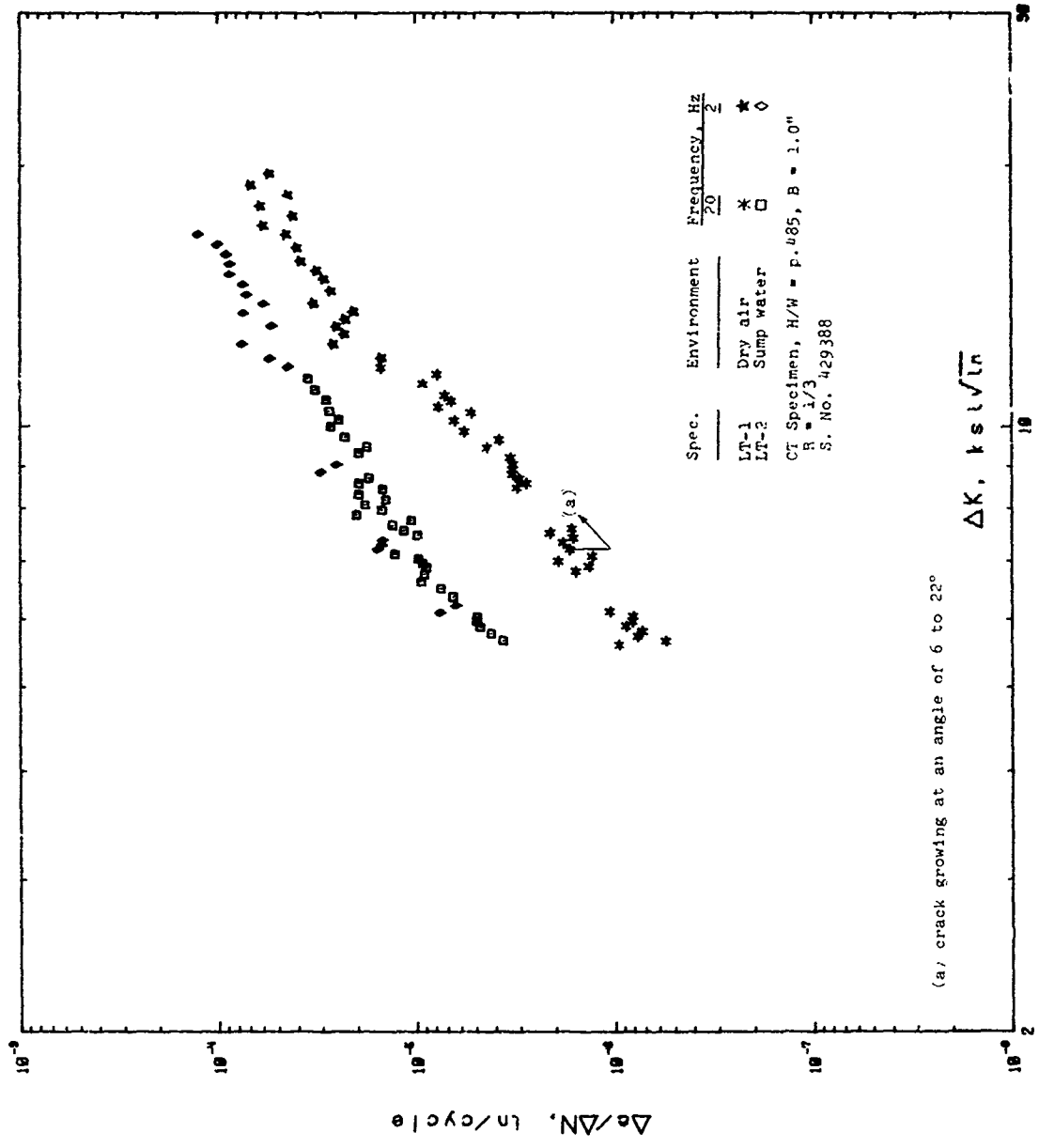

Fig. 43 Fatigue Crack-Growth Data for 1-in. 7475-T7351 Plate
L-T Orientation

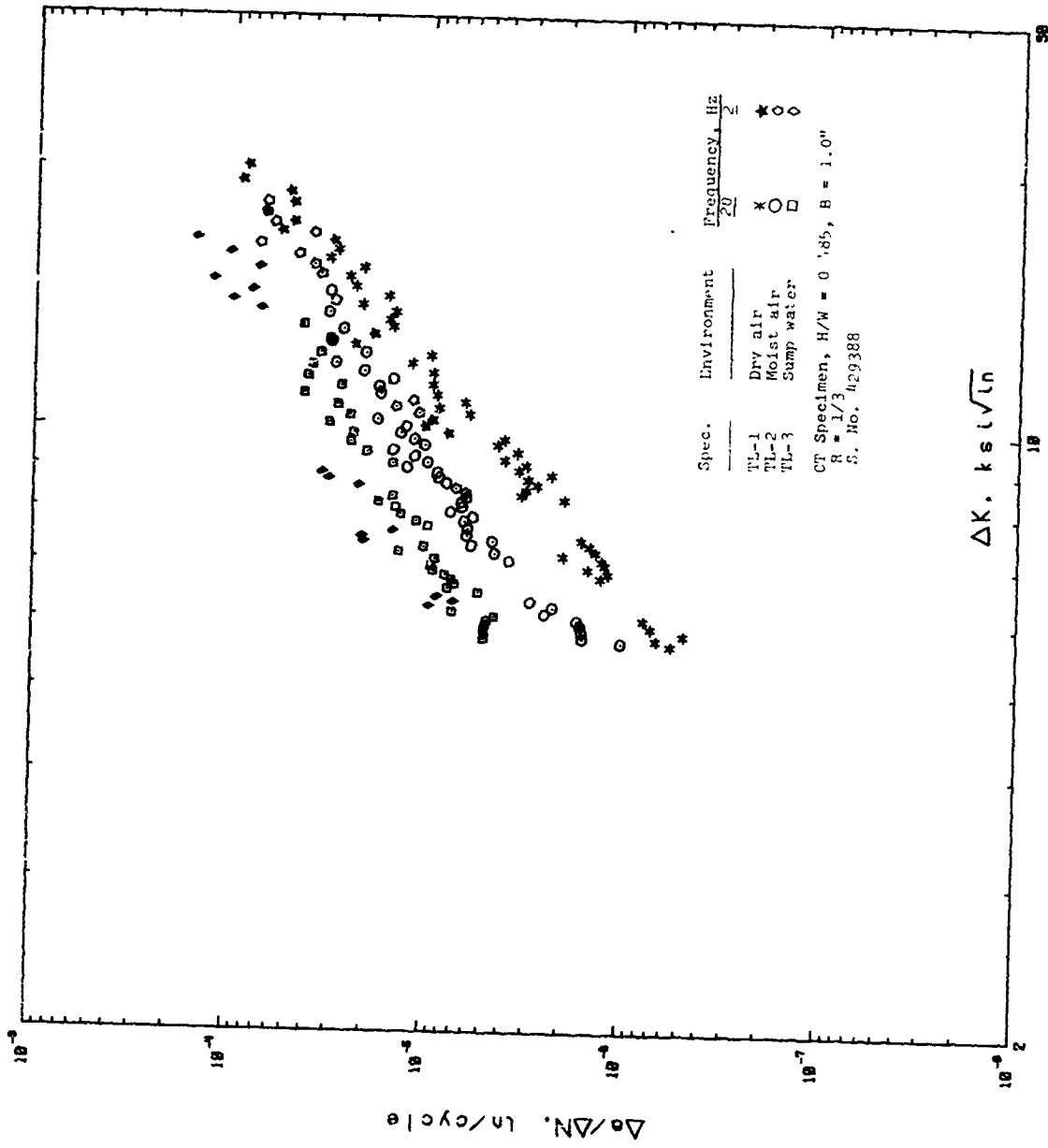

Fig. 44 Fatigue Crack-Growth Data for 1-in. 7475-T7351 Plate
 T-L Orientation

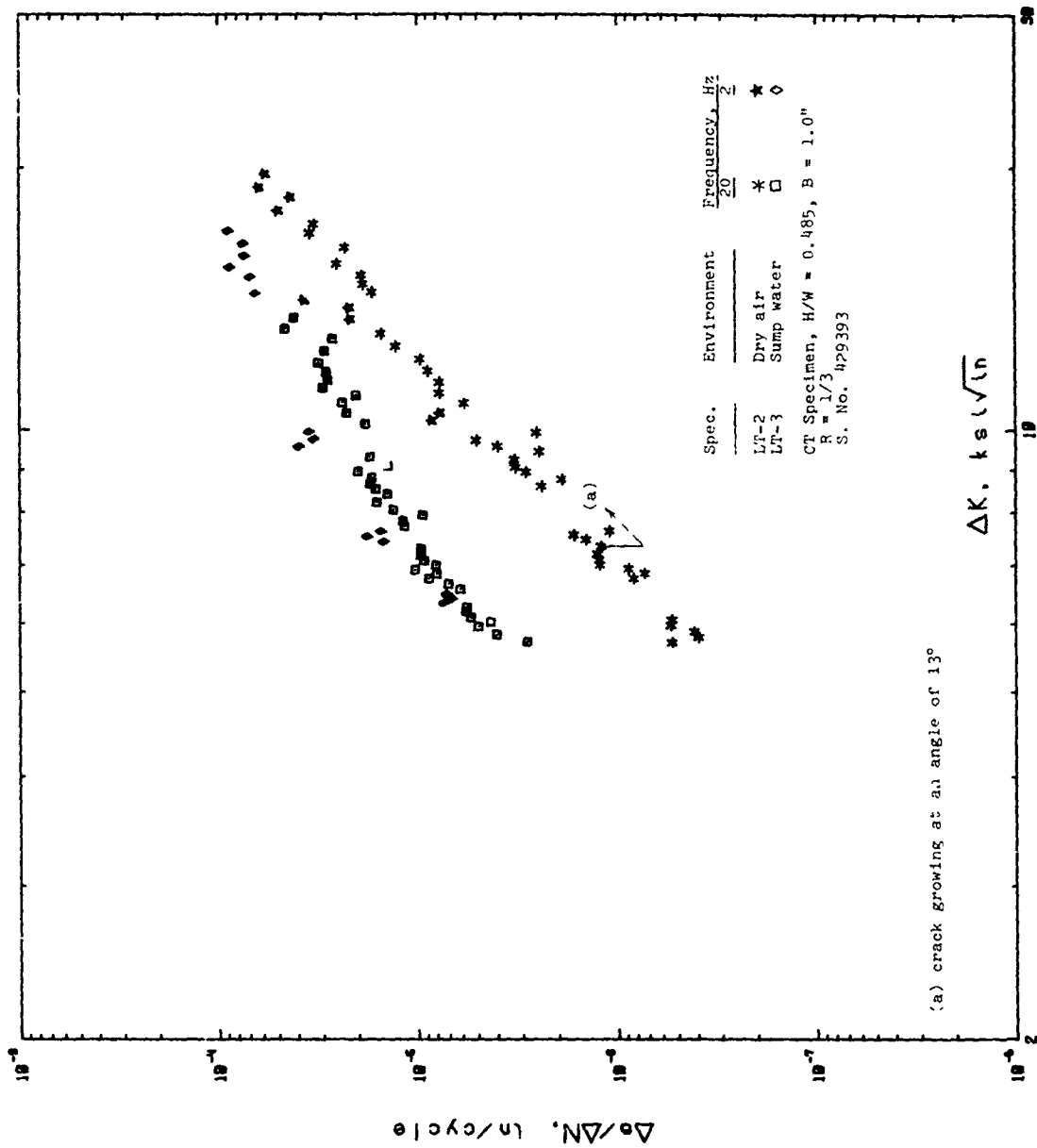

Fig. 45 Fatigue Crack-Growth Data for 4-in. 7475-T7351 Plate
 L-T Orientation

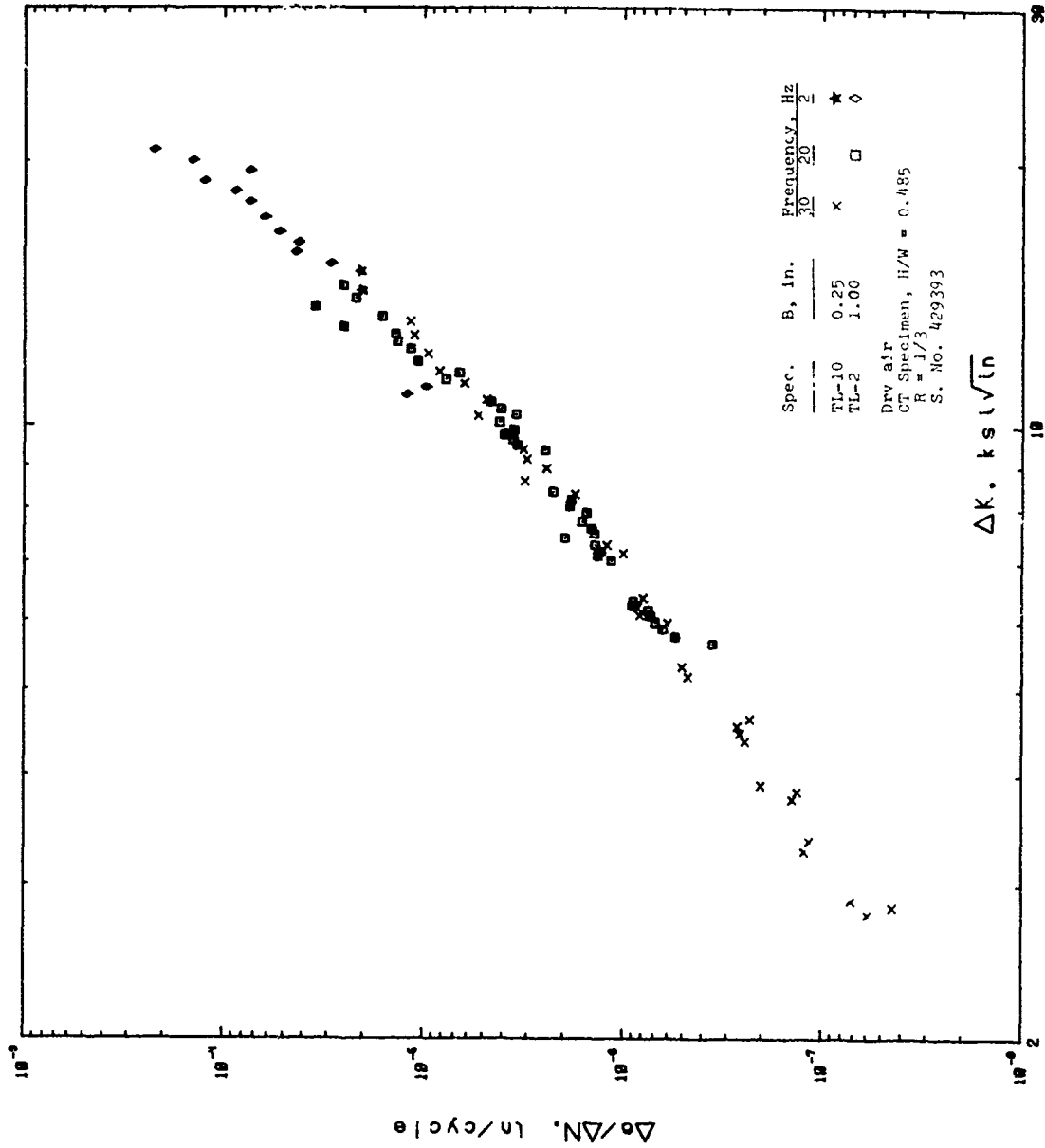

FIG. 46 Fatigue Crack-Growth Data for 4-in. 7475-T7351 Plate
I-I Orientation (dry air)

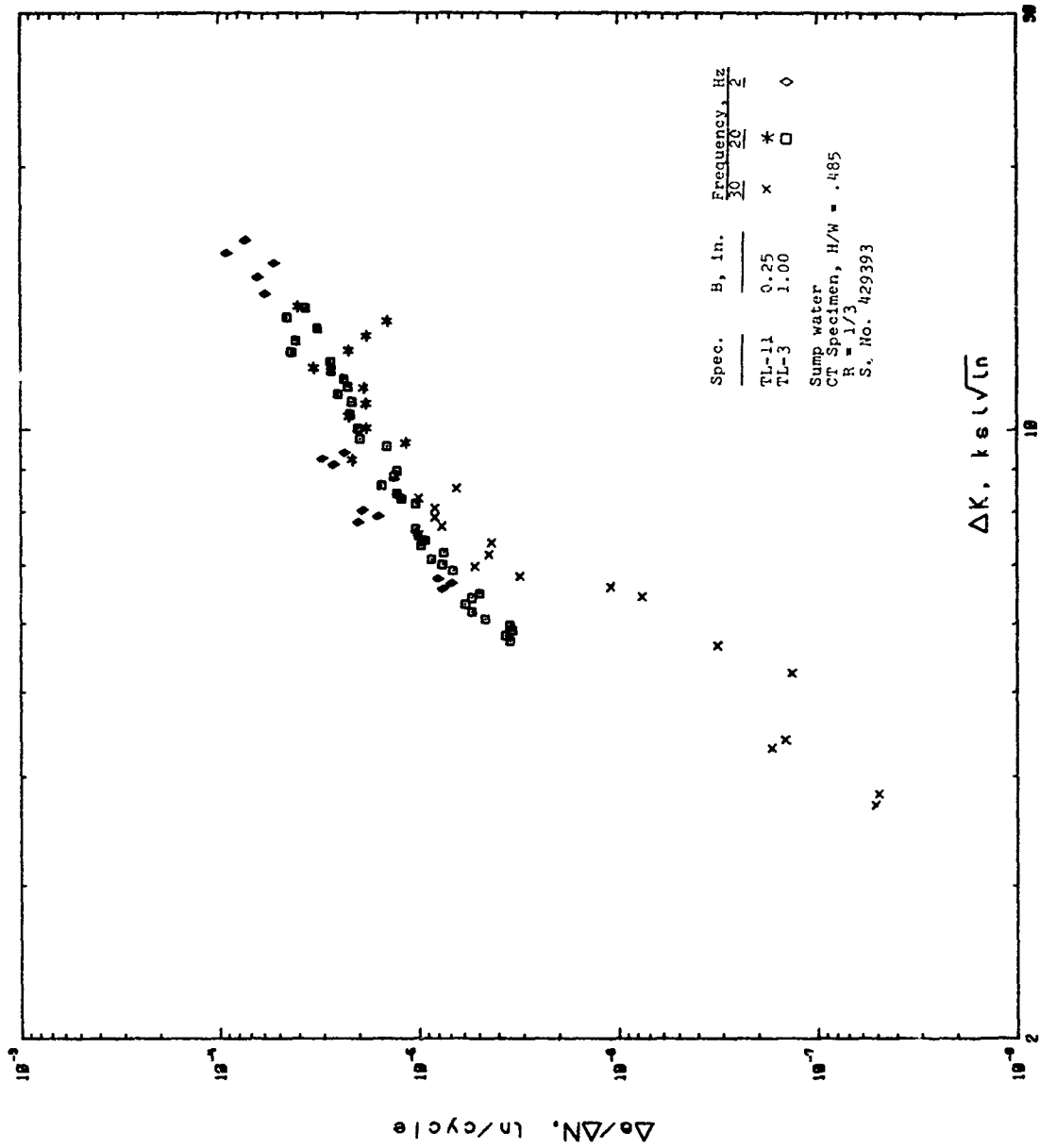

Fig. 47 Fatigue Crack-Growth Data for 4-in. 7475-T7351 Plate
T-L Orientation (sump water)

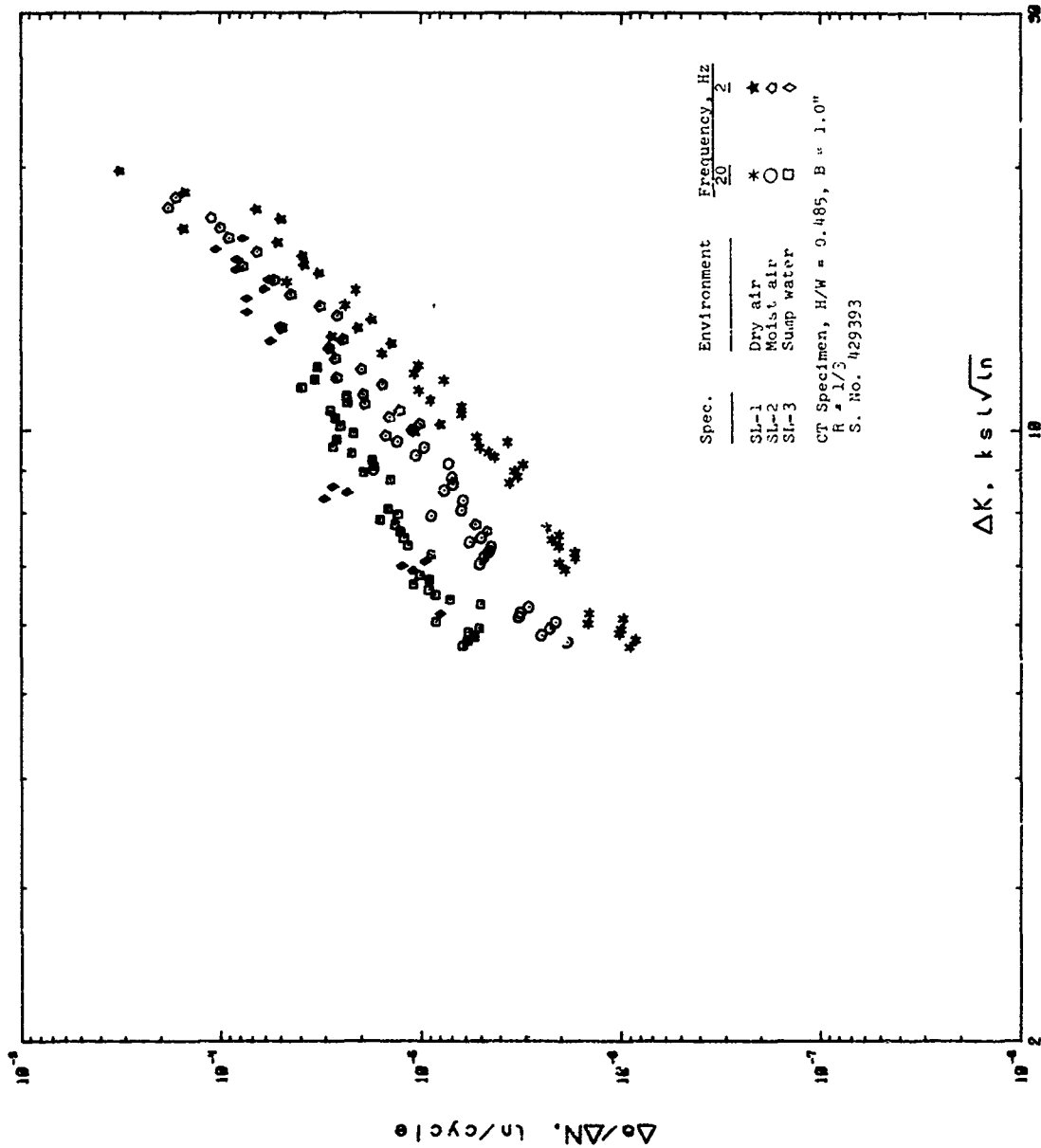

Fig. 48 Fatigue Crack-growth Data for 4-in. 7475-T7351 Plate
S-L Orientation

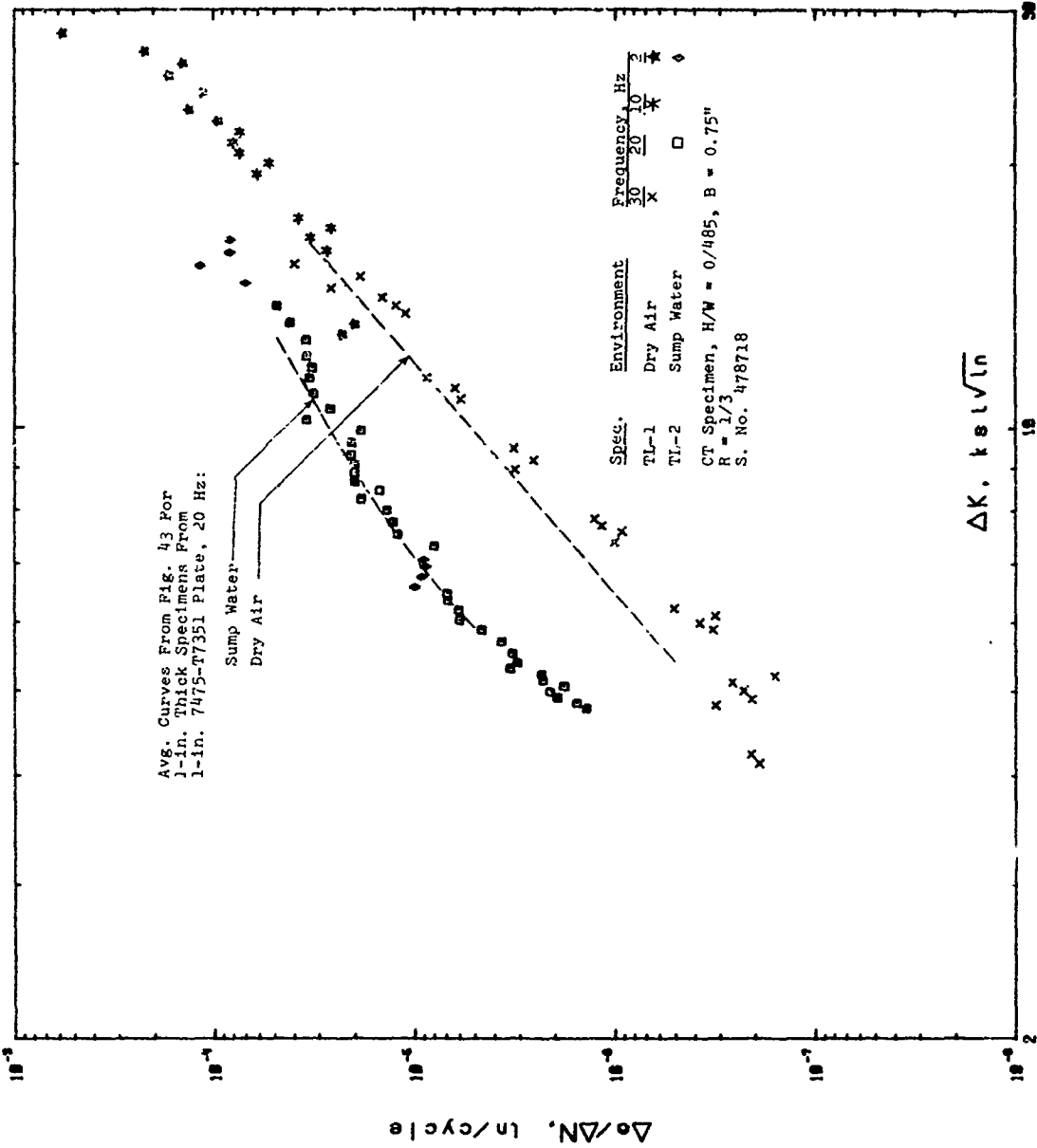

Fig. 49 Fatigue-Crack Growth Data for 3/4 in. 7475-T7351 Plate (Current Practice)
T-L Orientation

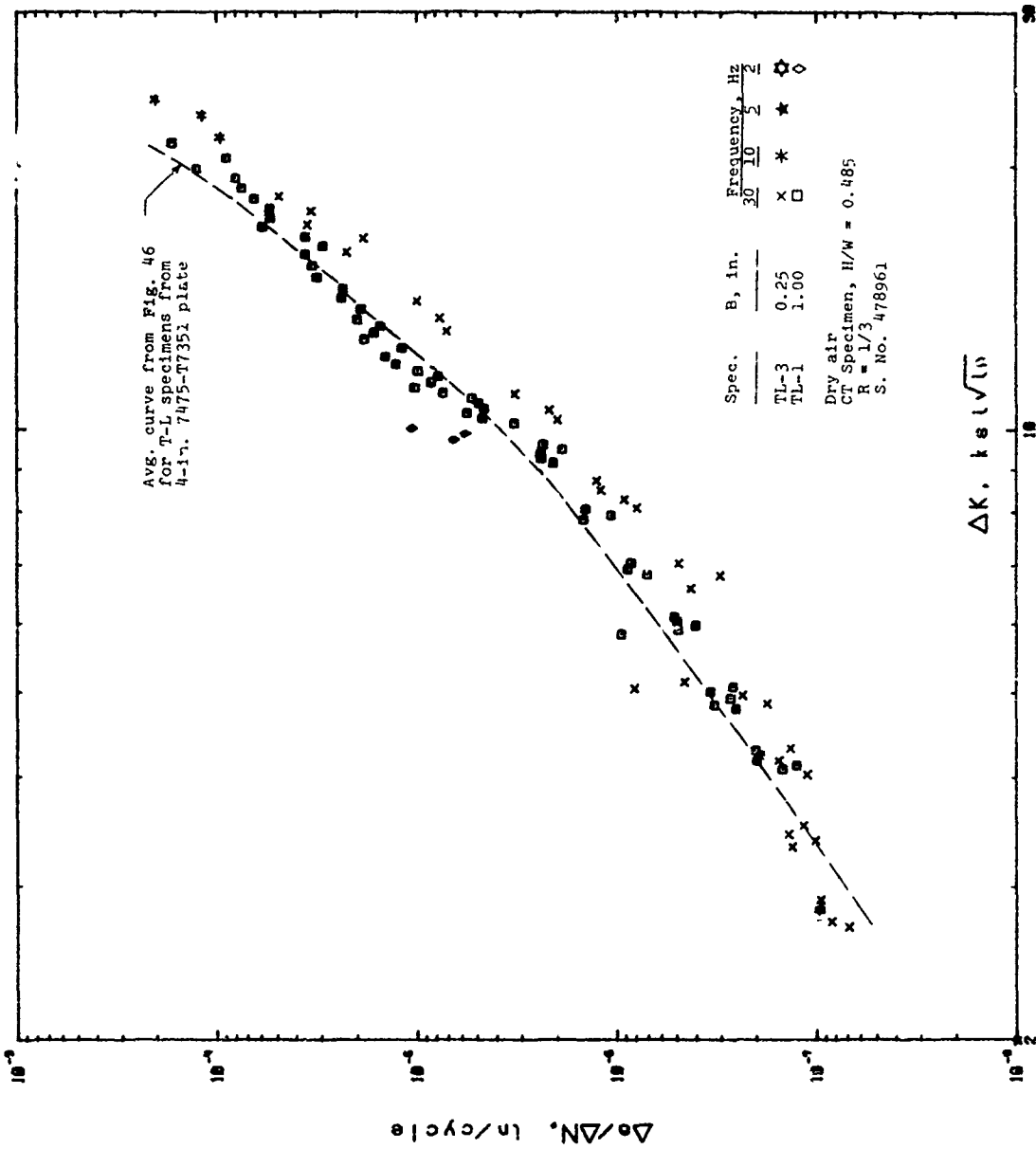

Fig. 50 Fatigue Crack-Growth Data for 3.5-in. 7475-T7351 Plate (Current Practice), T-L Orientation (dry air)

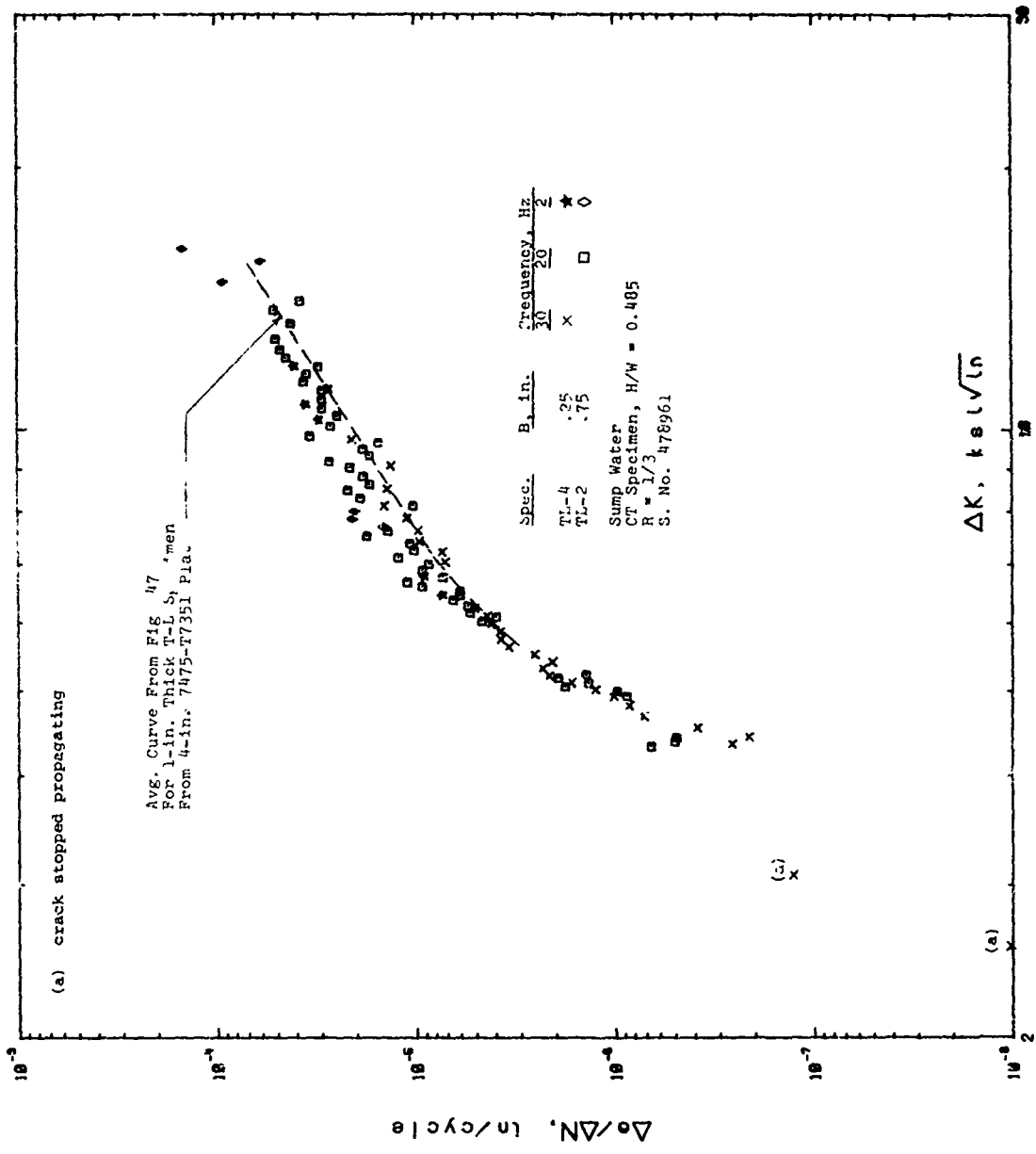

Fig. 51 Fatigue-Crack Growth Data for 3.5 in. 7475-T7351 Plate (Current Practice)
T-L Orientation (Sump Water)

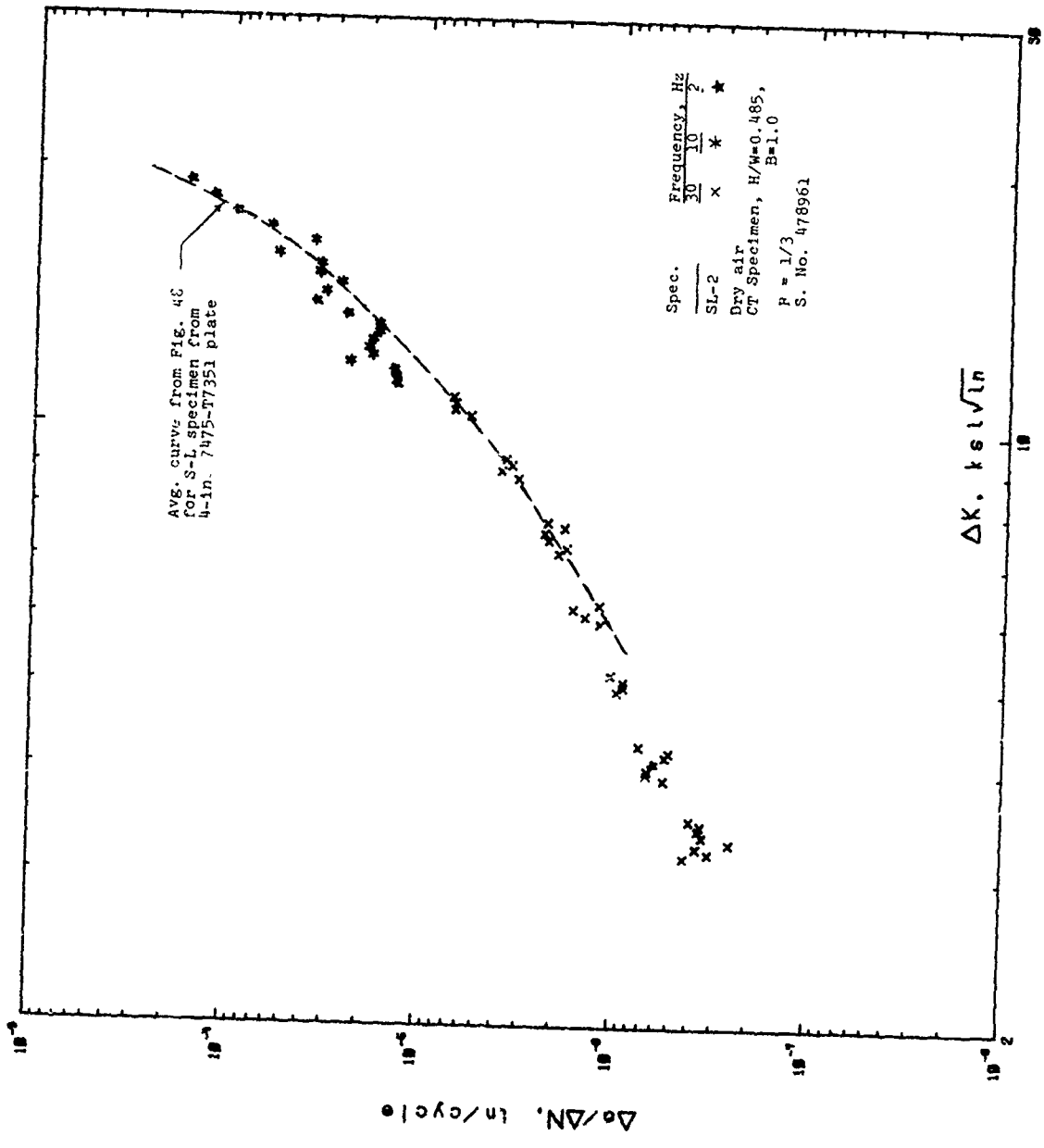

Fig. 52. Fatigue-Crack Growth Data for 3.5-in. 7475-T7351 Plate (Current Practice)
S-L Orientation (dry air)

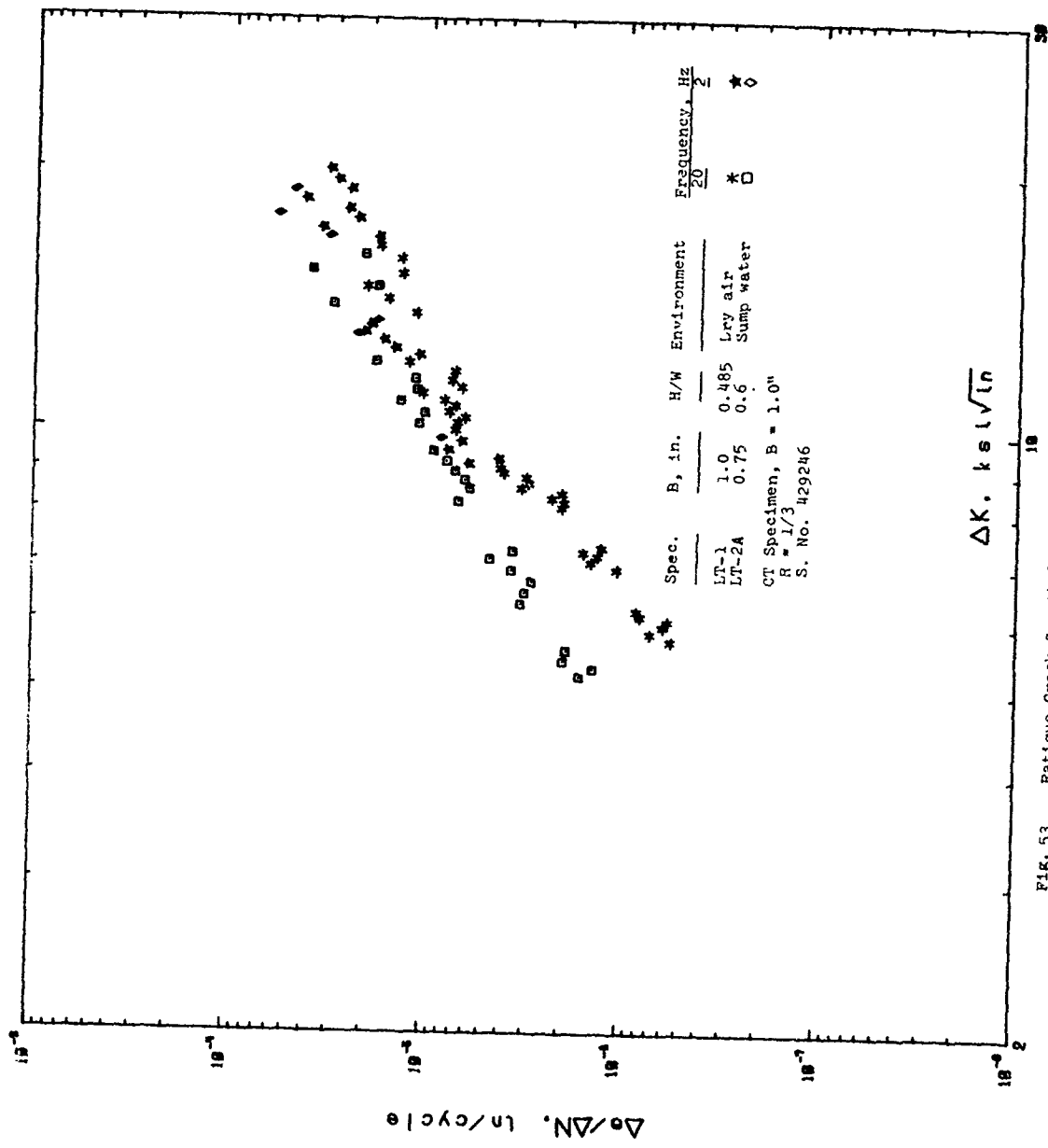

Fig. 53 Fatigue Crack-Growth Data for a 2 x 8-in. 2219-T852 Hand Forging
L-T Orientation

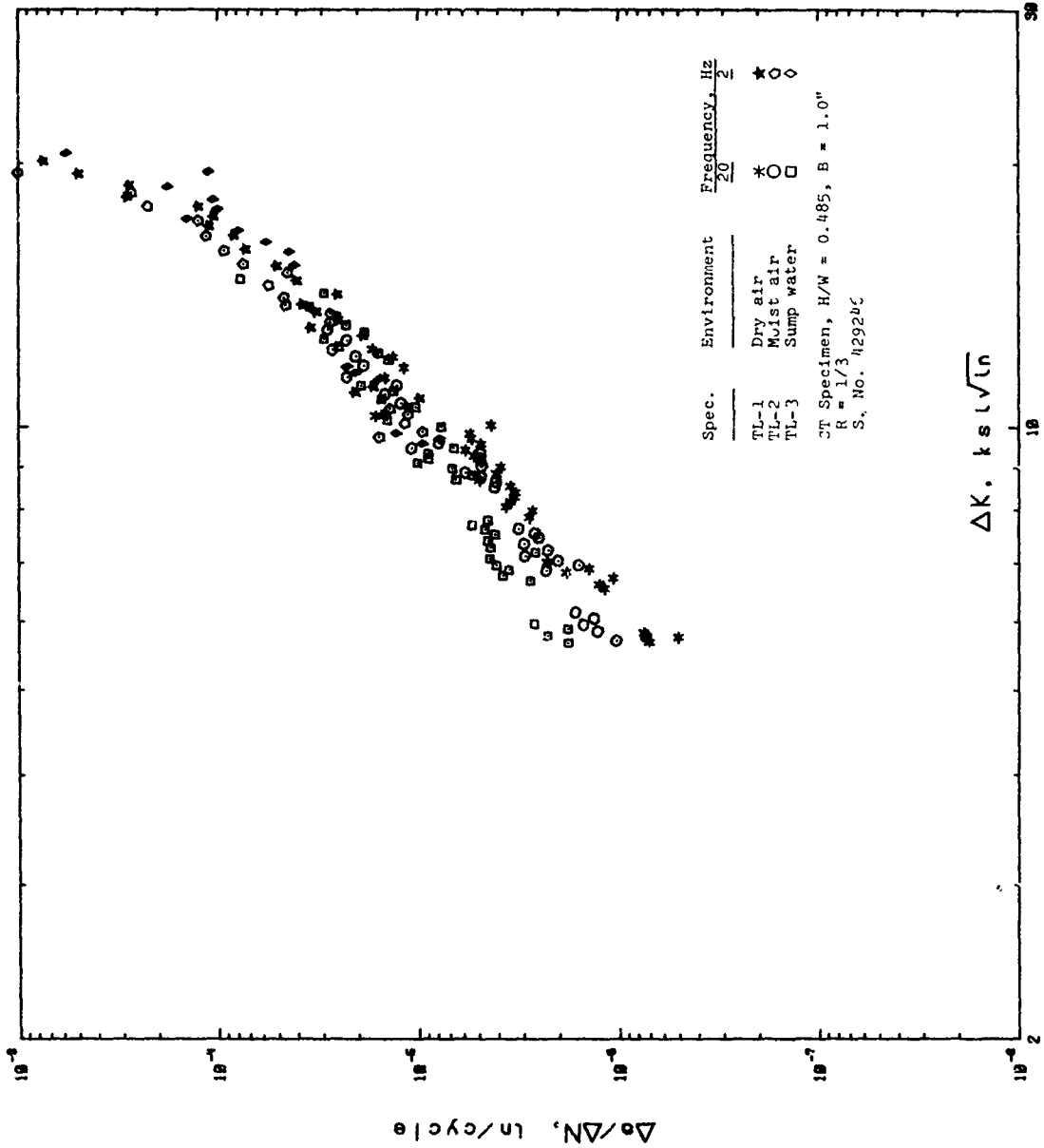

Fig. 54⁶ Fatigue Crack-Growth Data for a 7 x 8-in. 2219-T852 Hand Forging
T-L Orientation

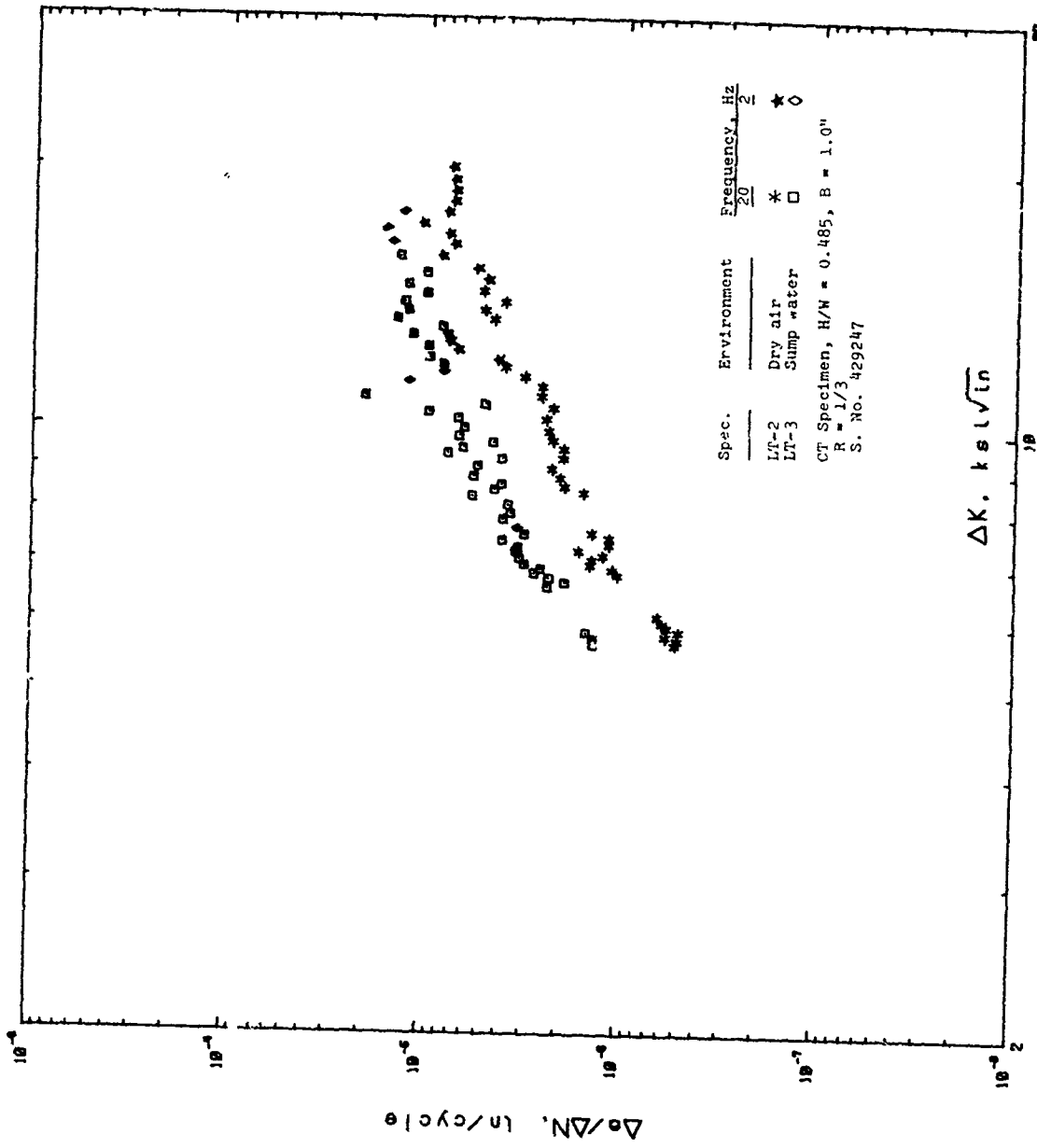

Fig. 55 Fatigue Crack-Growth Data for a 5.5 x 2.1-in. 4219-T852 Hand Forging
 L-T Orientation

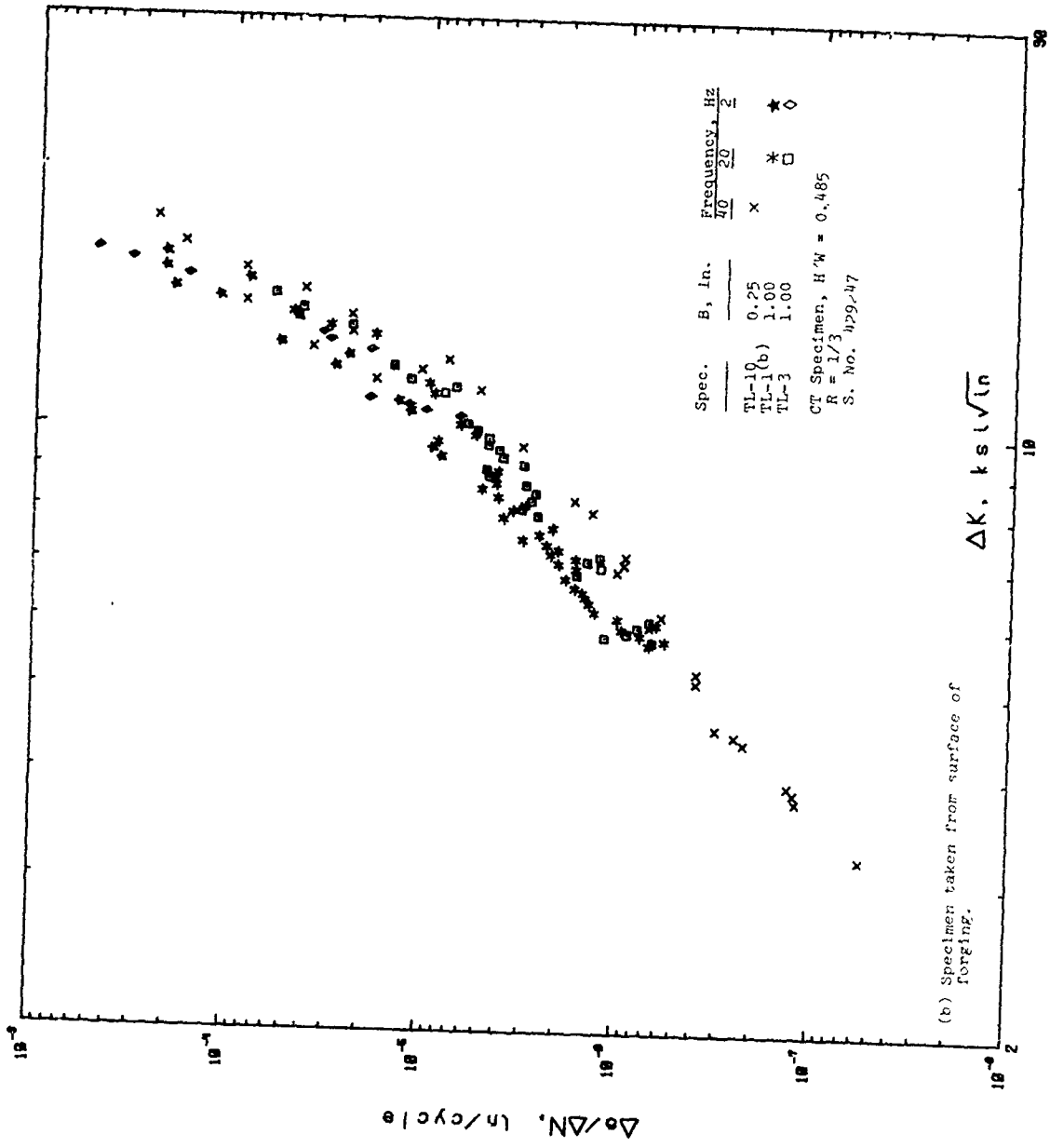

Fig. 56 Fatigue Crack-Growth Data for a 5.5 x 22-in. 2219-T852 Hard Forging T-L Orientation (dry air)

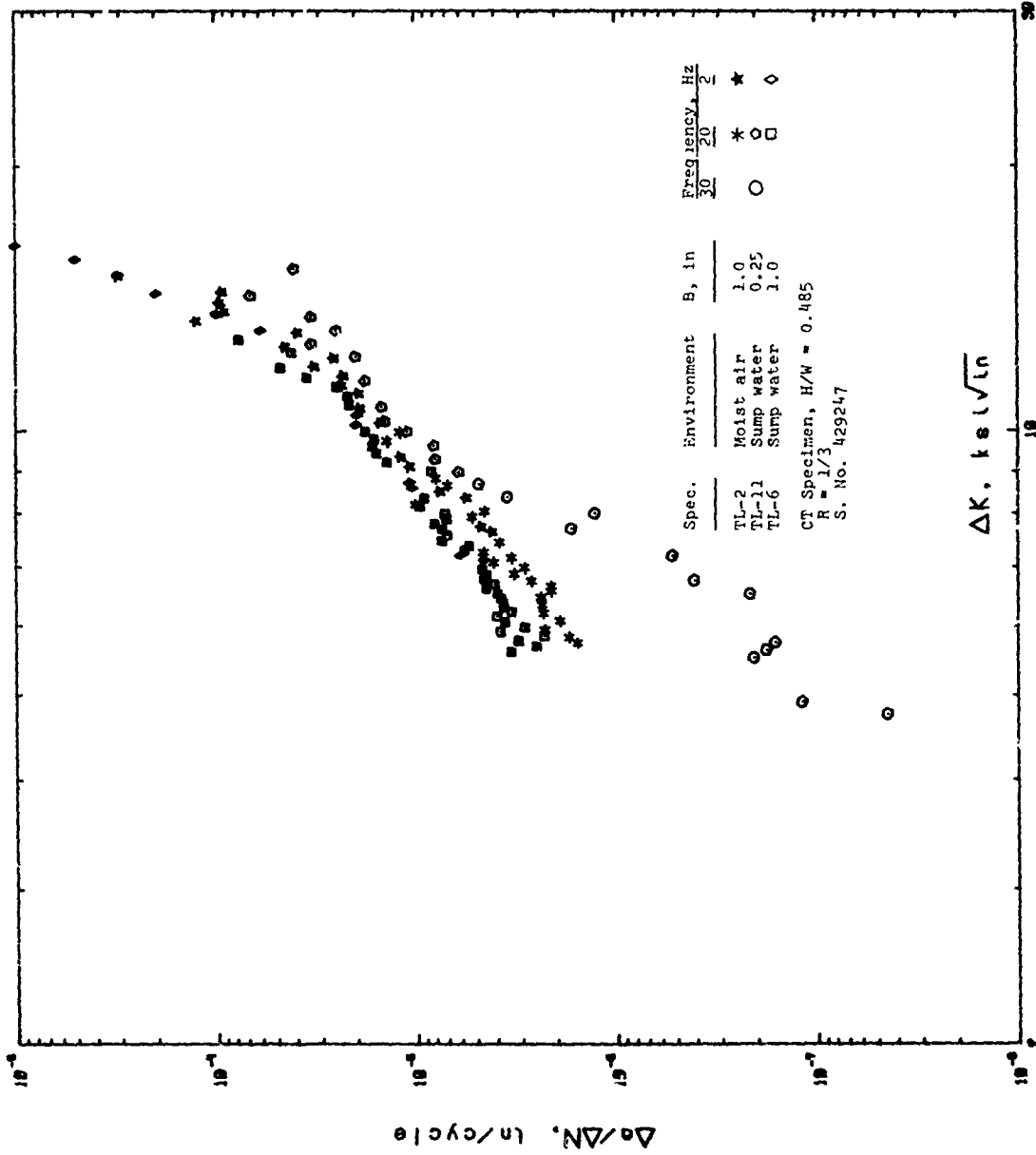

Fig. 57 Fatigue Crack-Growth Data for a 5.5 x 22-in. 2219-T852 Hand Forging
 1-L Orientation

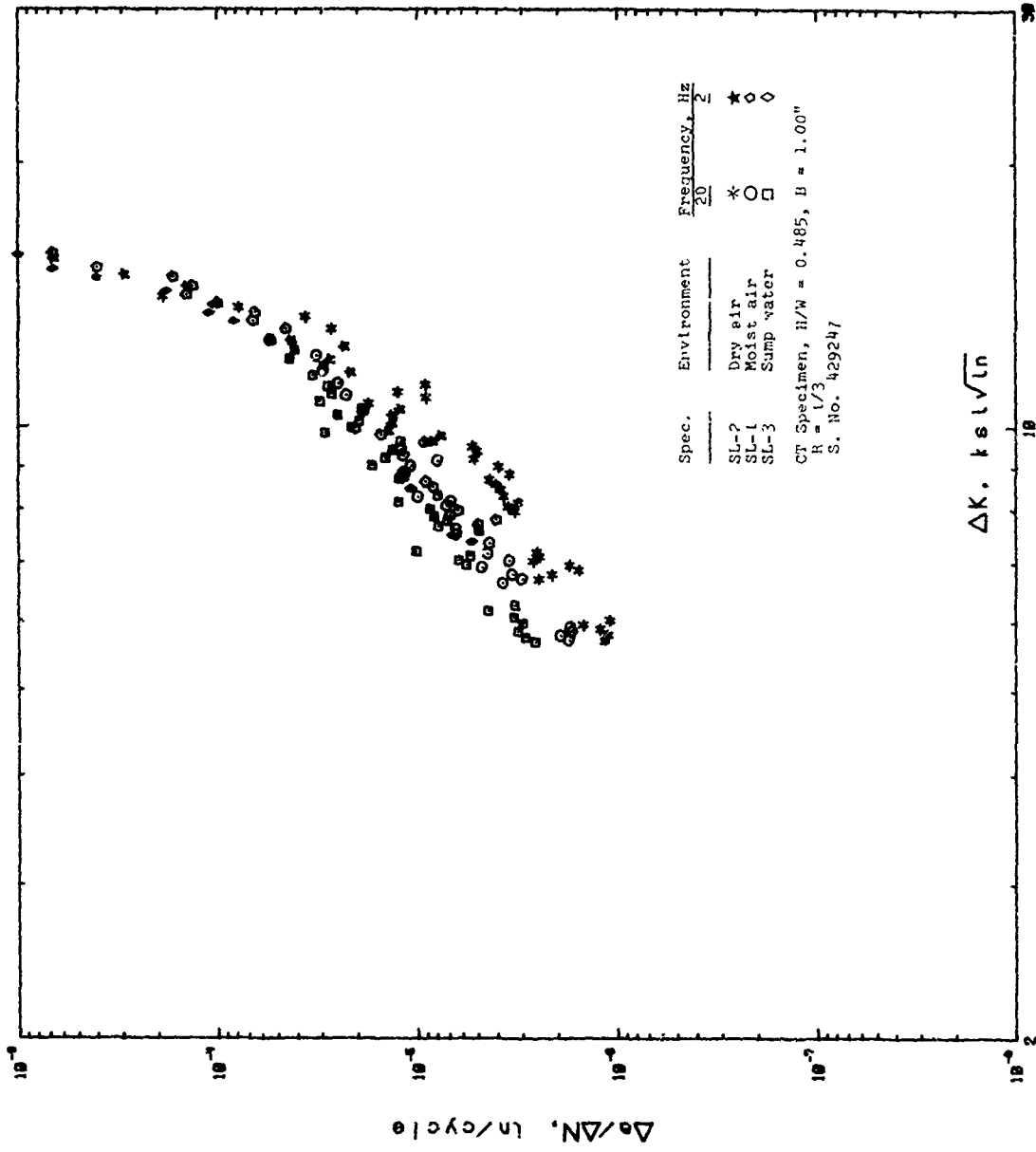

Fig. 56 Fatigue Crack-Growth Data for a 5.5 x 22-in. 2219-T52 Hand Forging S-L Orientation

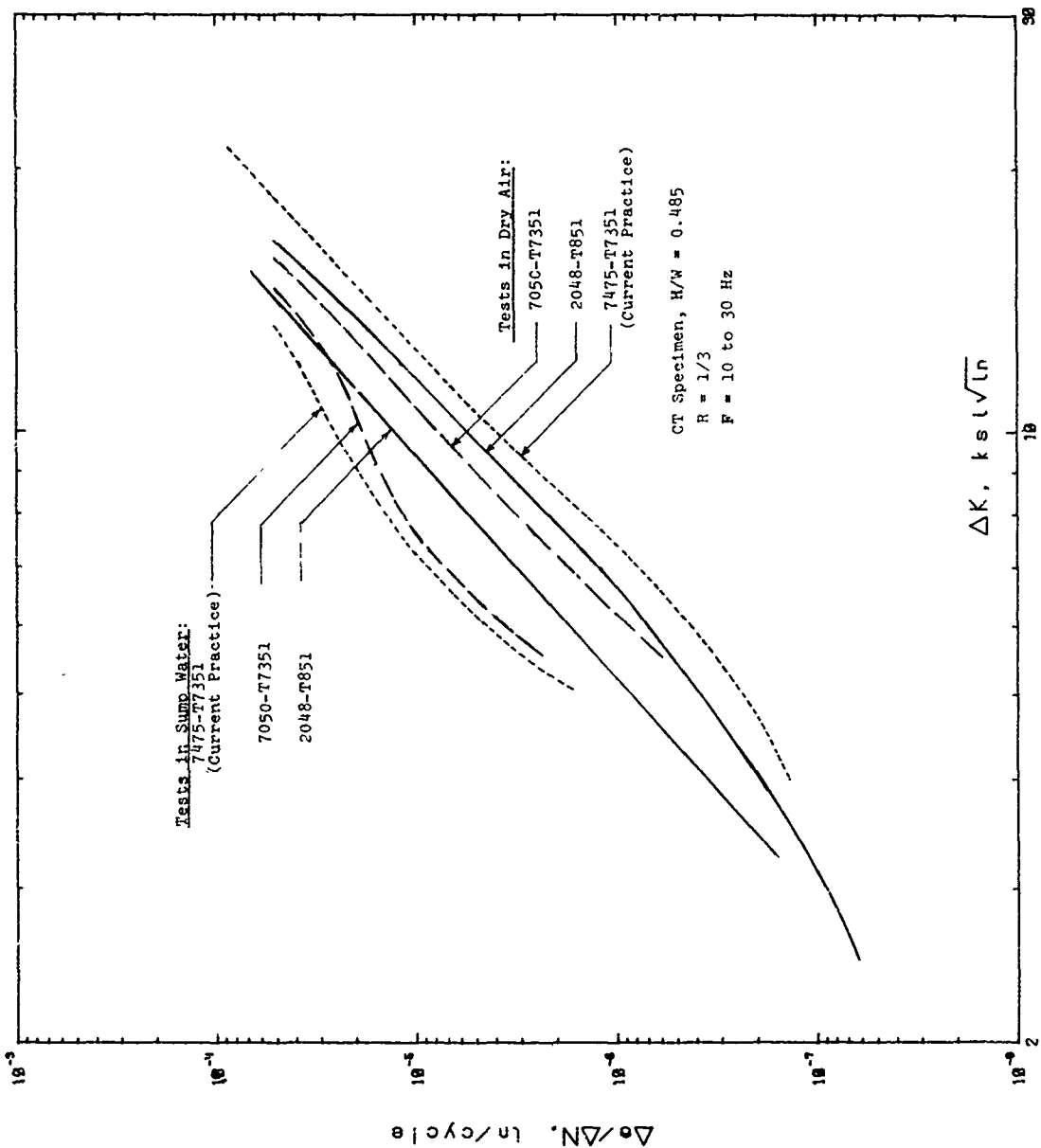

Fig. 59 Comparison of Fatigue-Crack Growth Rates for Thick Plate T-L Orientation

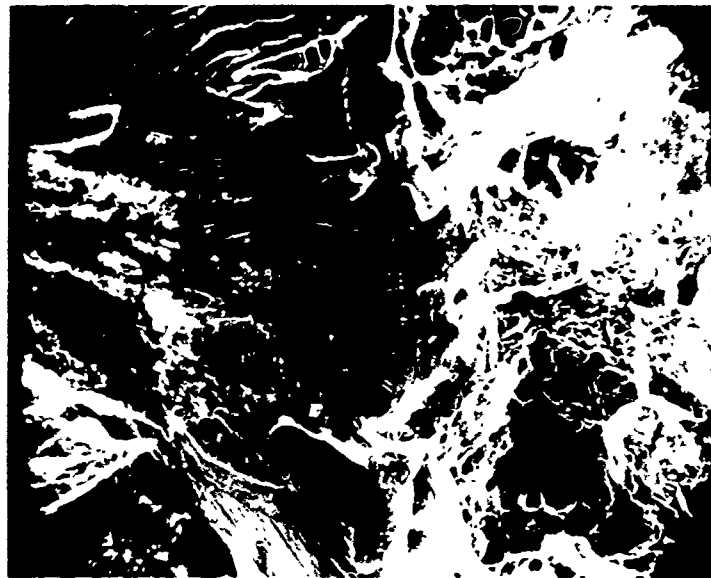
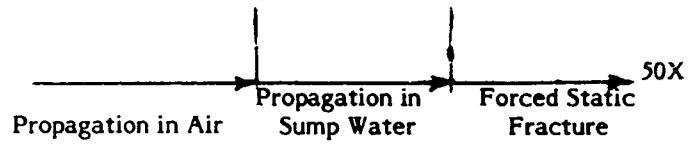
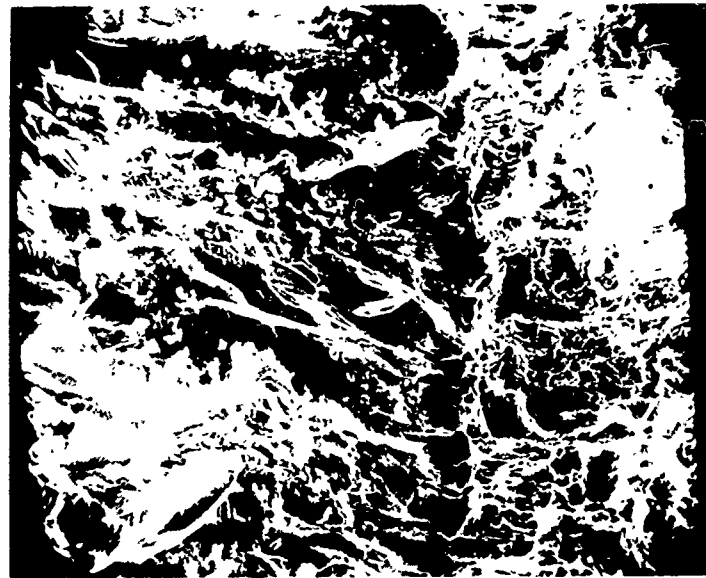
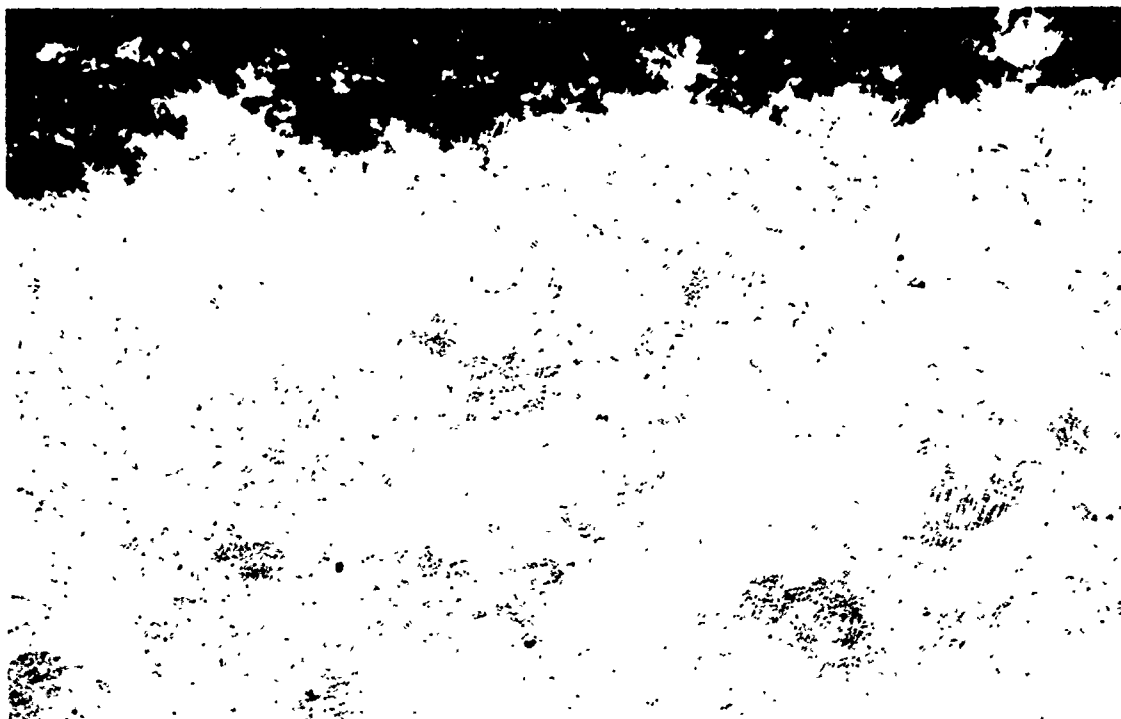

Fig. 60 Sump Water Induced Arrest of Low Growth Rate Fatigue Crack in 7475-T7351 Plate (S.E.M.) 200X



S. No. 478817-E2

Neg. 205122-A

Mag: 100X

Fig. 61 Illustrates type of attack in center plane test panel from a 2.5-inch thick 2219-T852 alloy hand forging exposed to EXCO test.



S. No. 478817-E2

Neg. 205123

Mag: 500X

Fig. 62 View of Figure 61 at a higher magnification.

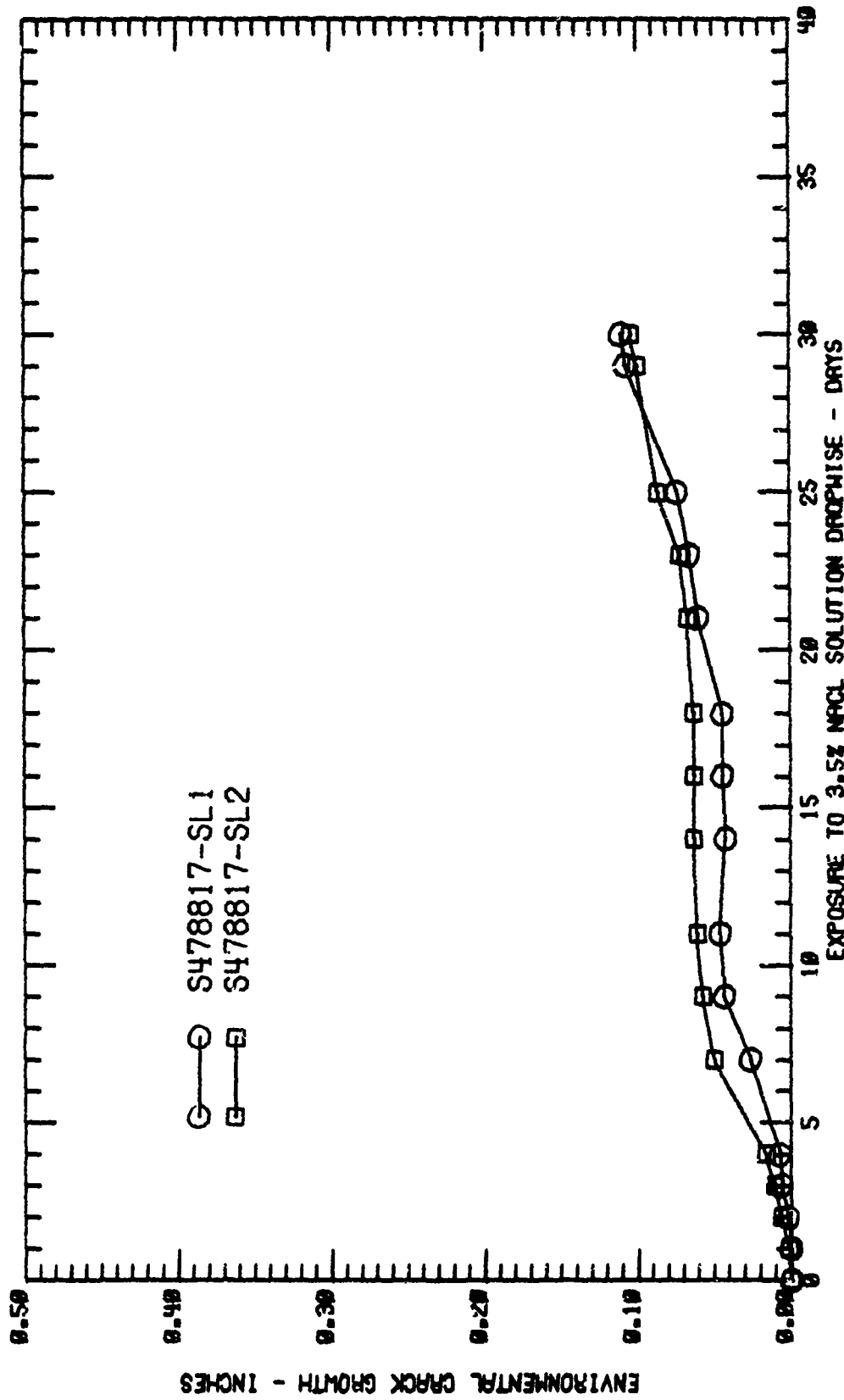

Fig. 63 ENVIRONMENTAL CRACK GROWTH OF SHORT TRANSVERSE 2219-1852 ALLOY DCB SPECIMENS REMOVED FROM A 2.5-INCH THICK HAND FORGING.

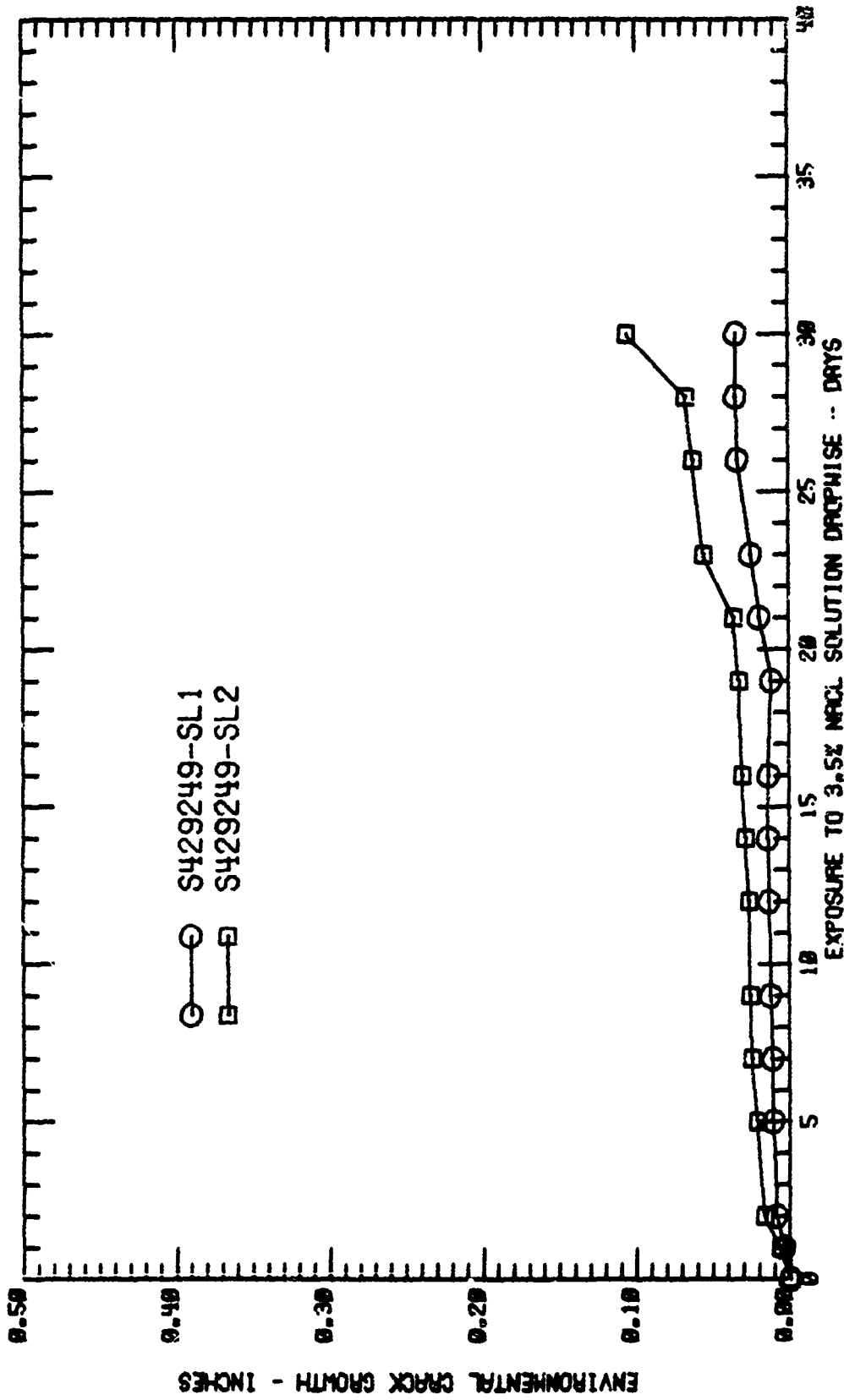

FIG. 64 ENVIRONMENTAL CRACK GROWTH OF SHORT TRANSVERSE 2219--T852 ALLOY DCB SPECIMENS REMOVED FROM A 4.5-INCH THICK HAND FORGING.

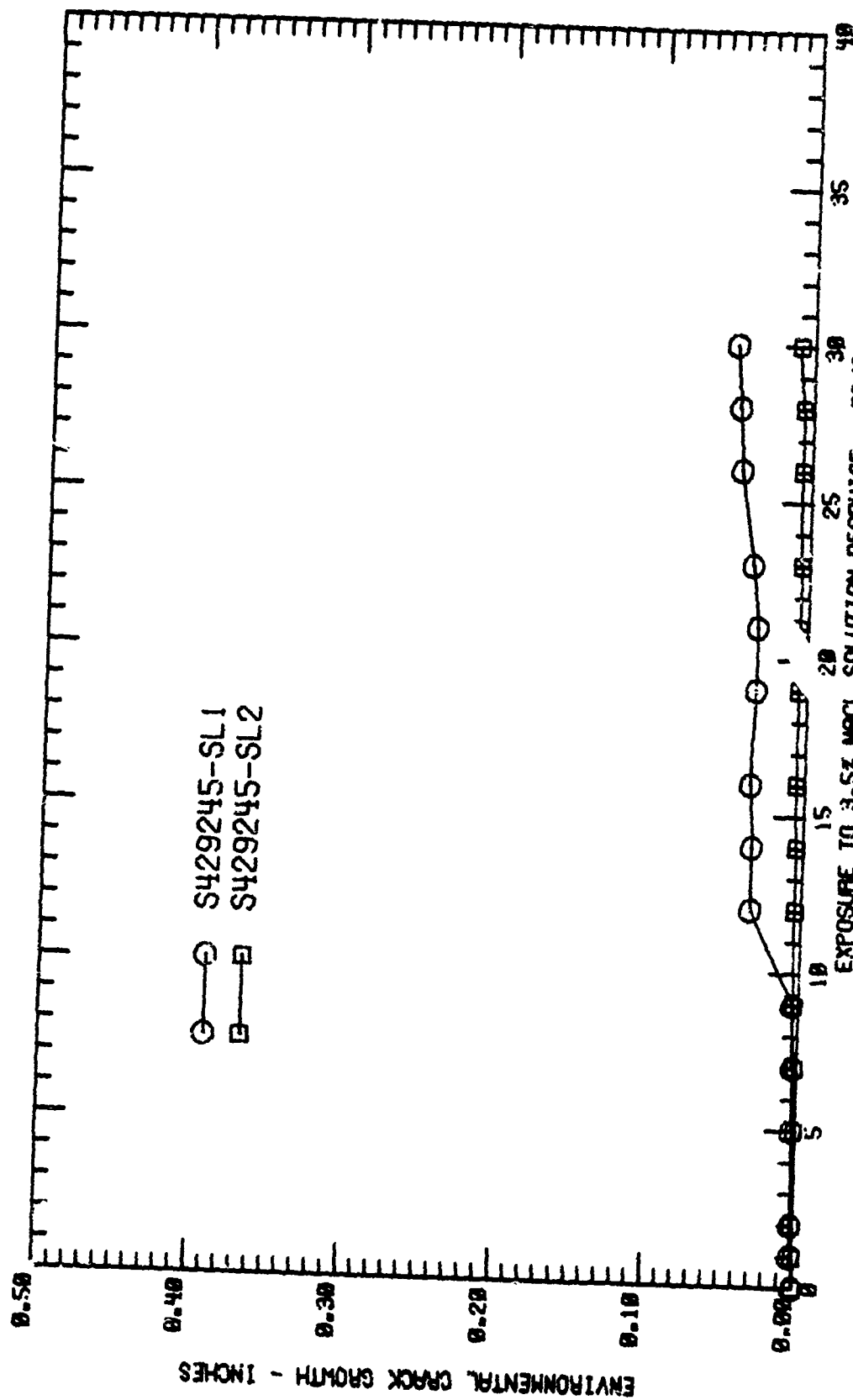

Fig. 65 ENVIRONMENTAL CRACK GROWTH OF SHORT TRANSVERSE 2219-T852 ALLOY DCB SPECIMENS REMOVED FROM A 7.5-INCH THICK HAND FORGING.

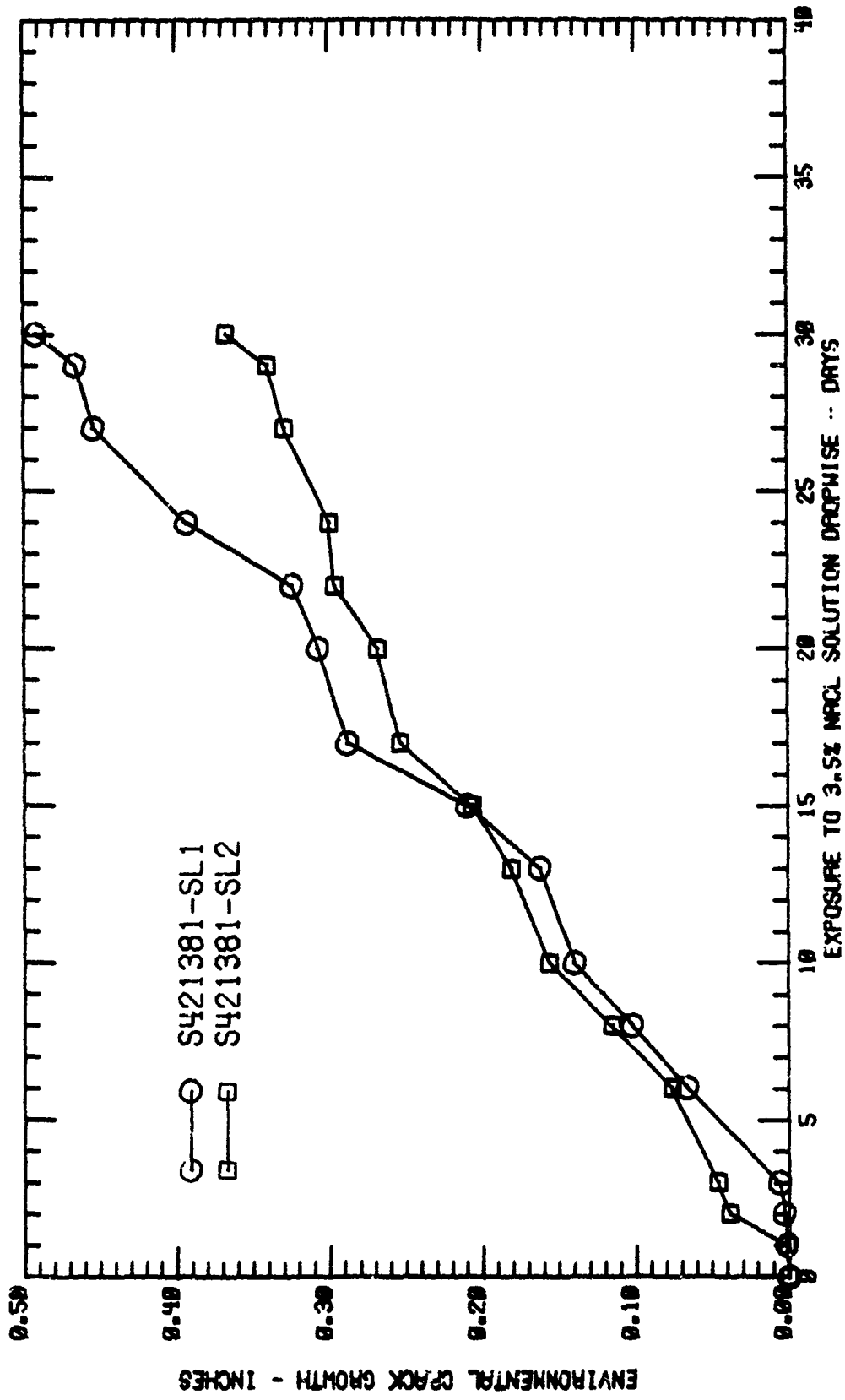

Fig. 66 ENVIRONMENTAL CRACK GROWTH OF SHORT TRANSVERSE 2048-T851 ALLOY DC3 SPECIMENS REMOVED FROM A 2-INCH THICK PLATE.

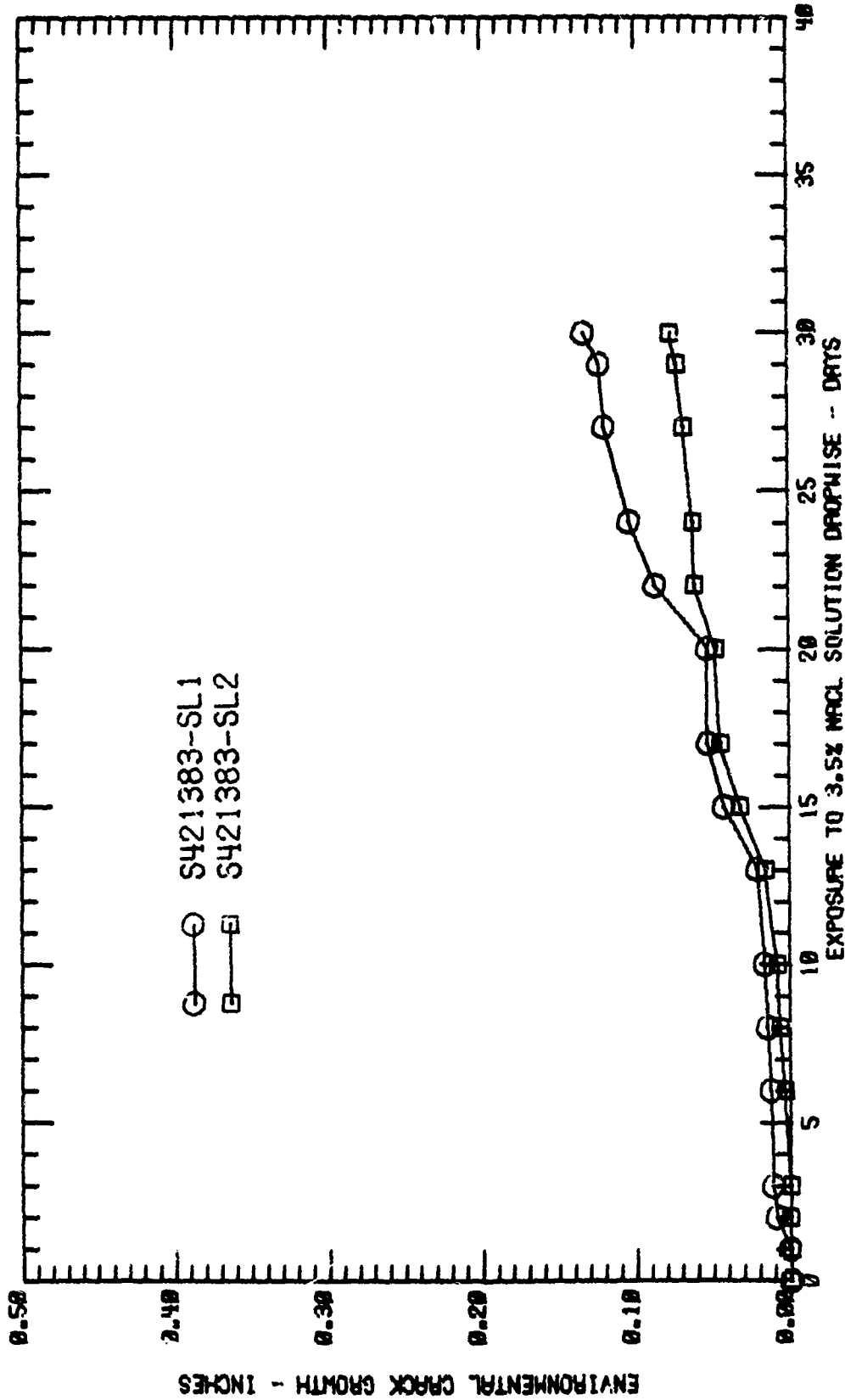

Fig. 67 ENVIRONMENTAL CRACK GROWTH OF SHORT TRANSVERSE 2048-T851 ALLOY DCB SPECIMENS REMOVED FROM A 4-INCH THICK PLATE.

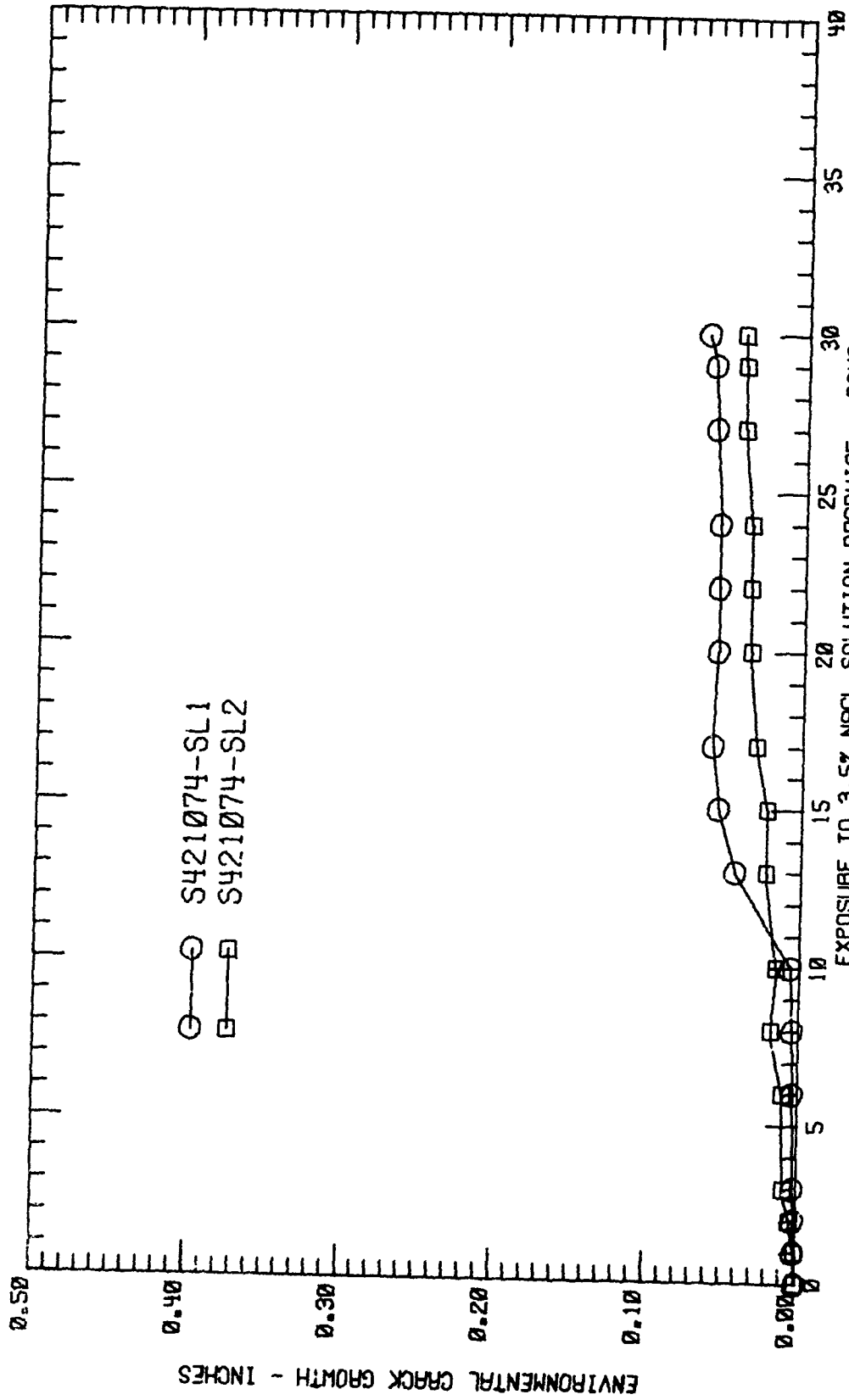

Fig. 68 ENVIRONMENTAL CRACK GROWTH OF SHORT TRANSVERSE 7050-T7351 ALLOY DCB SPECIMENS REMOVED FROM A 2-INCH THICK PLATE.

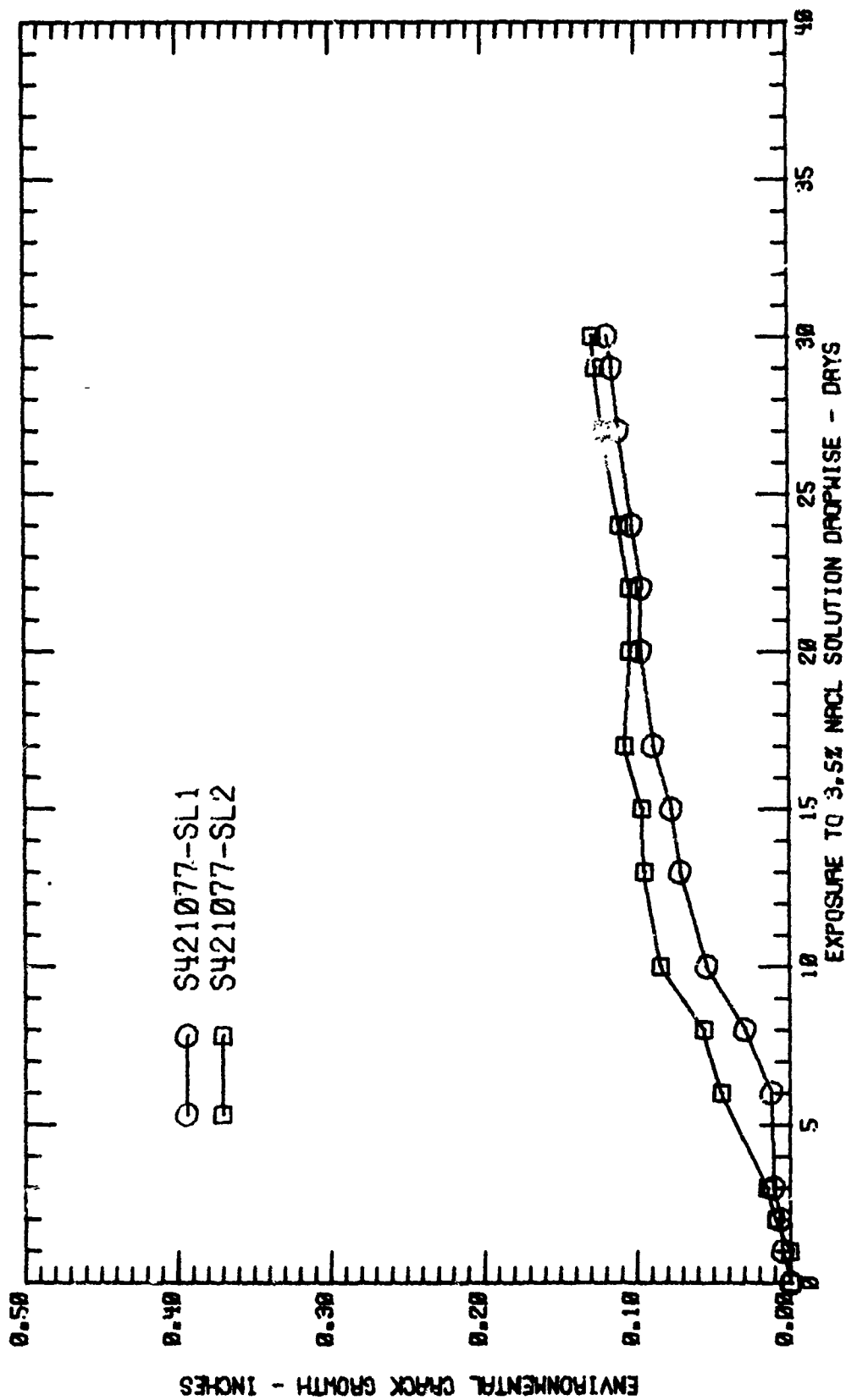

Fig. 69 ENVIRONMENTAL CRACK GROWTH OF SHORT TRANSVERSE 7050-T7351 ALLOY DCB SPECIMENS REMOVED FROM A 1/4-INCH THICK PLATE.

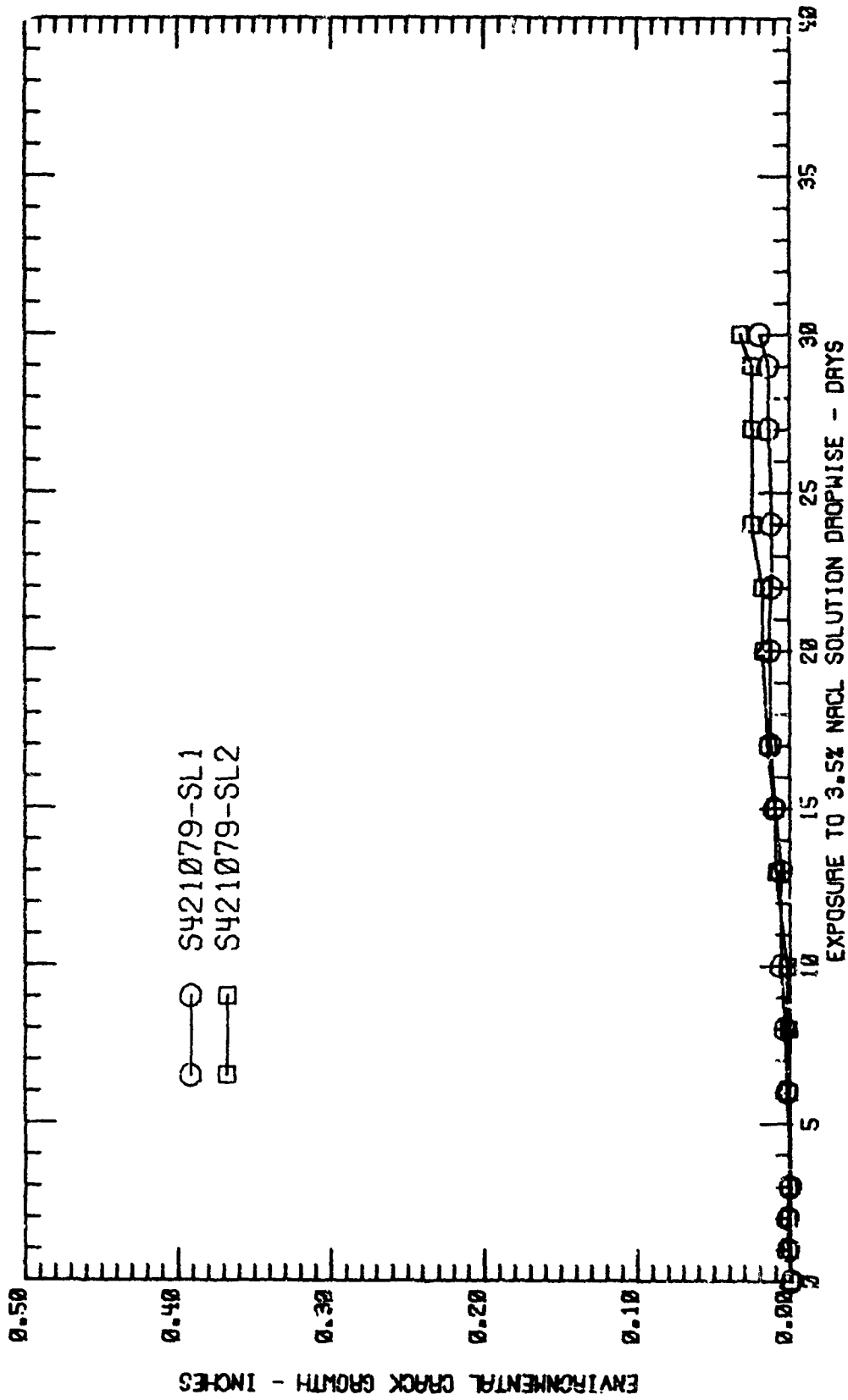

FIG. 70 ENVIRONMENTAL CRACK GROWTH OF SHORT TRANSVERSE 7050-T7351 ALLOY
 DCB SPECIMENS REMOVED FROM A 6-INCH THICK PLATE.

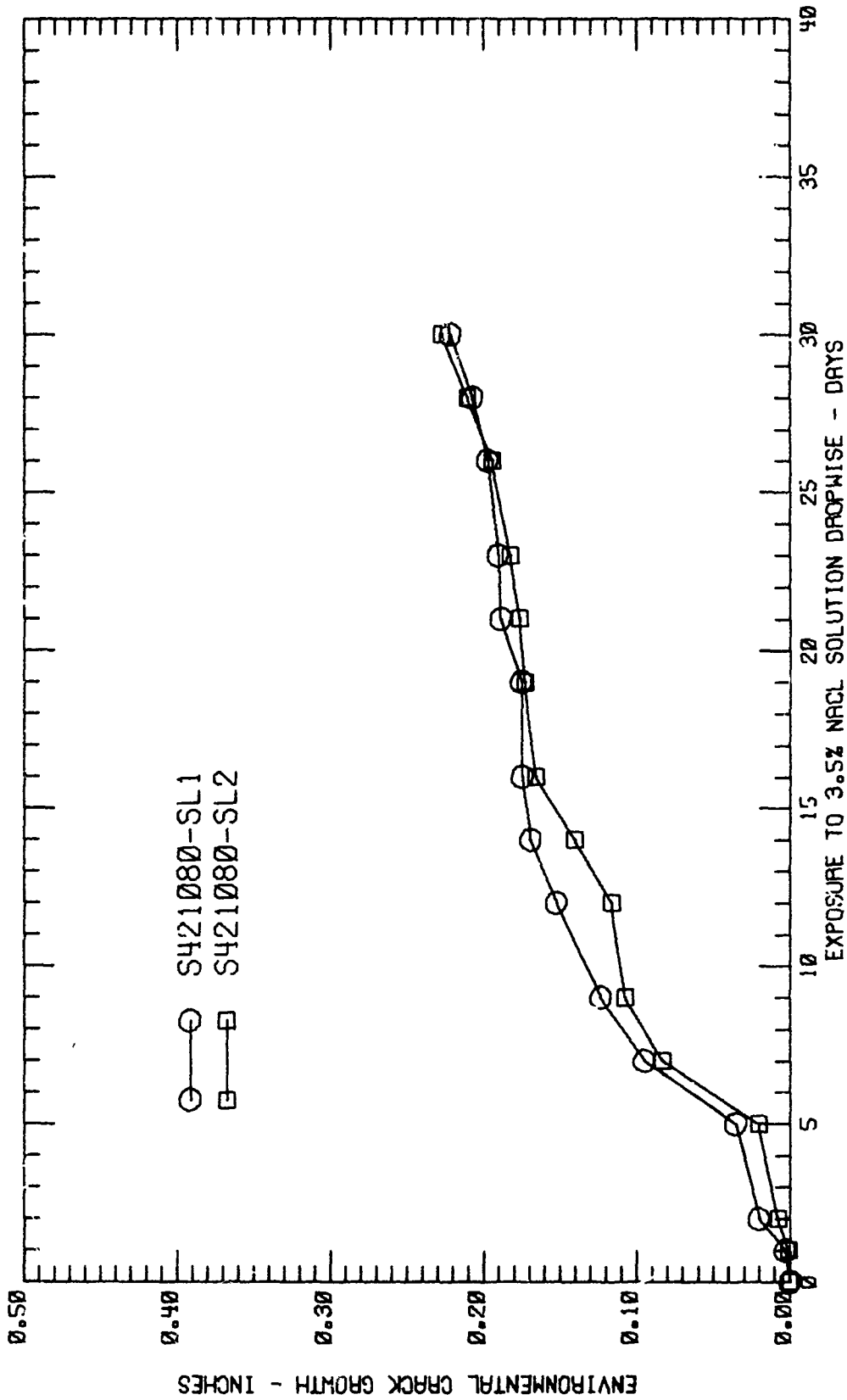

FIG. 71 ENVIRONMENTAL CRACK GROWTH OF SHORT TRANSVERSE 7050-T7351 ALLOY DCB SPECIMENS REMOVED FROM A 6-INCH THICK PLATE.

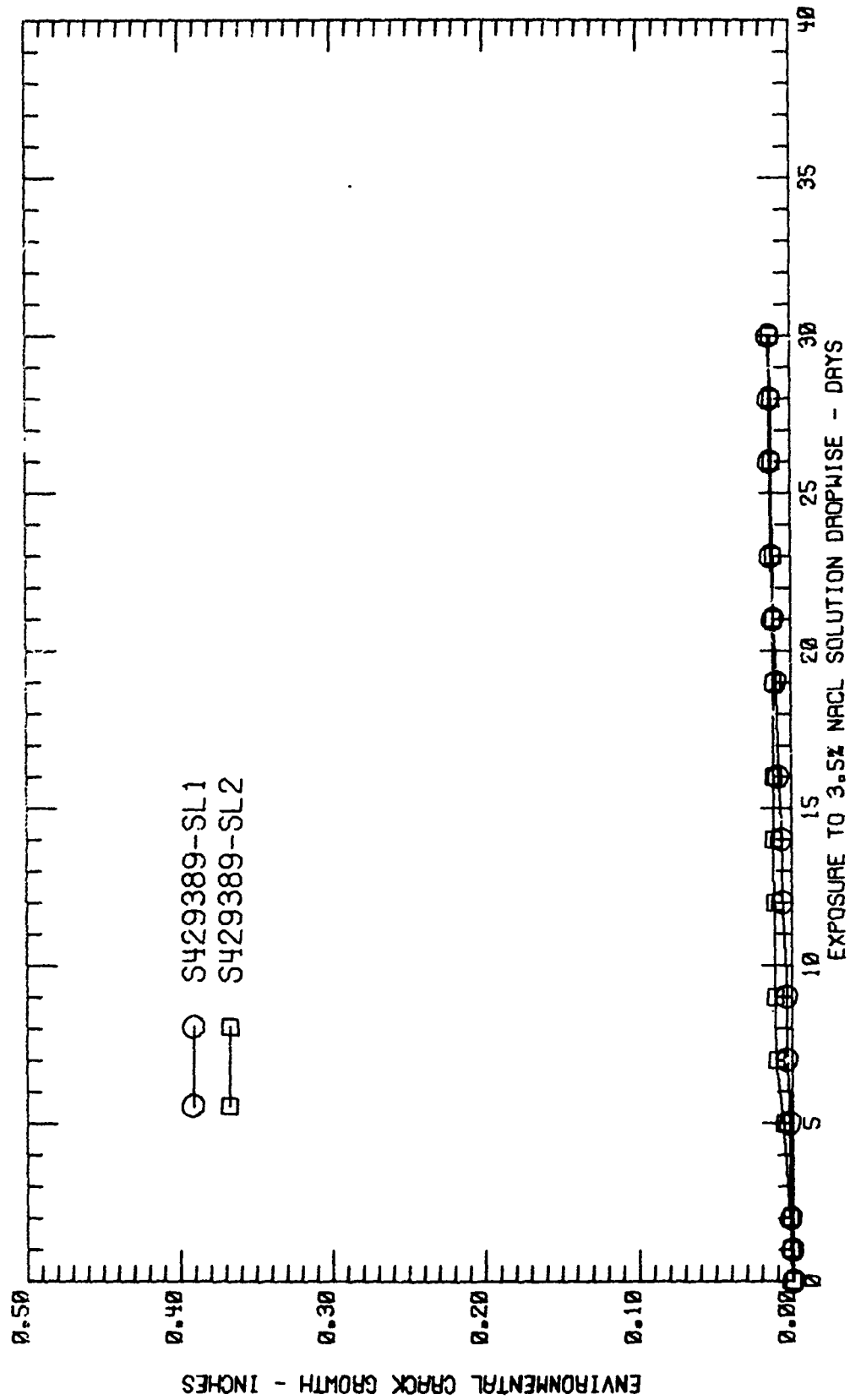

FIG. 72 ENVIRONMENTAL CRACK GROWTH OF SHORT TRANSVERSE 7475-T7351 ALLOY
DCB SPECIMENS REMOVED FROM A 2-INCH THICK PLATE.

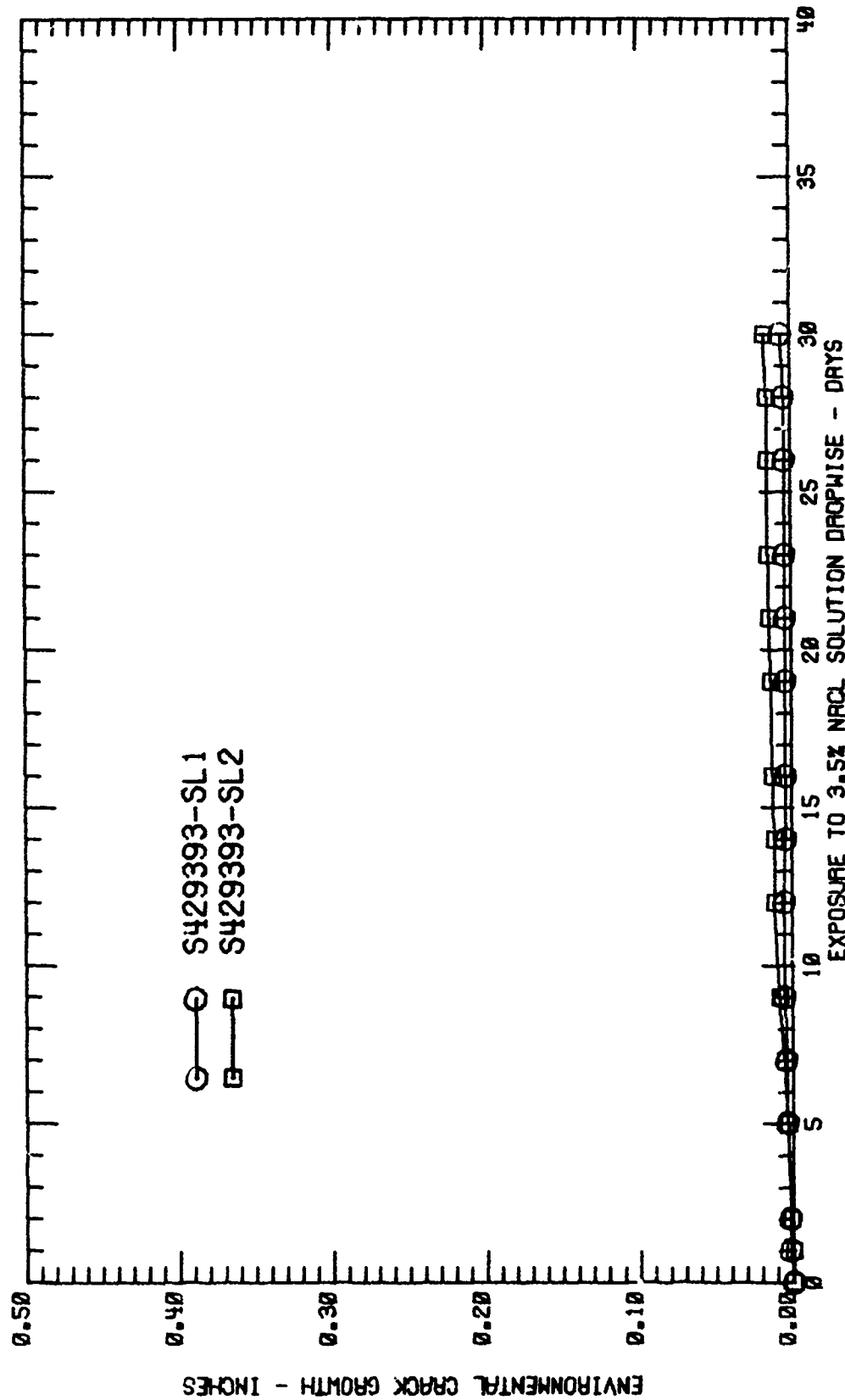

FIG. 73 ENVIRONMENTAL CRACK GROWTH OF SHORT TRANSVERSE 7475-T7351 ALLOY DCB SPECIMENS REMOVED FROM A 4-INCH THICK PLATE.

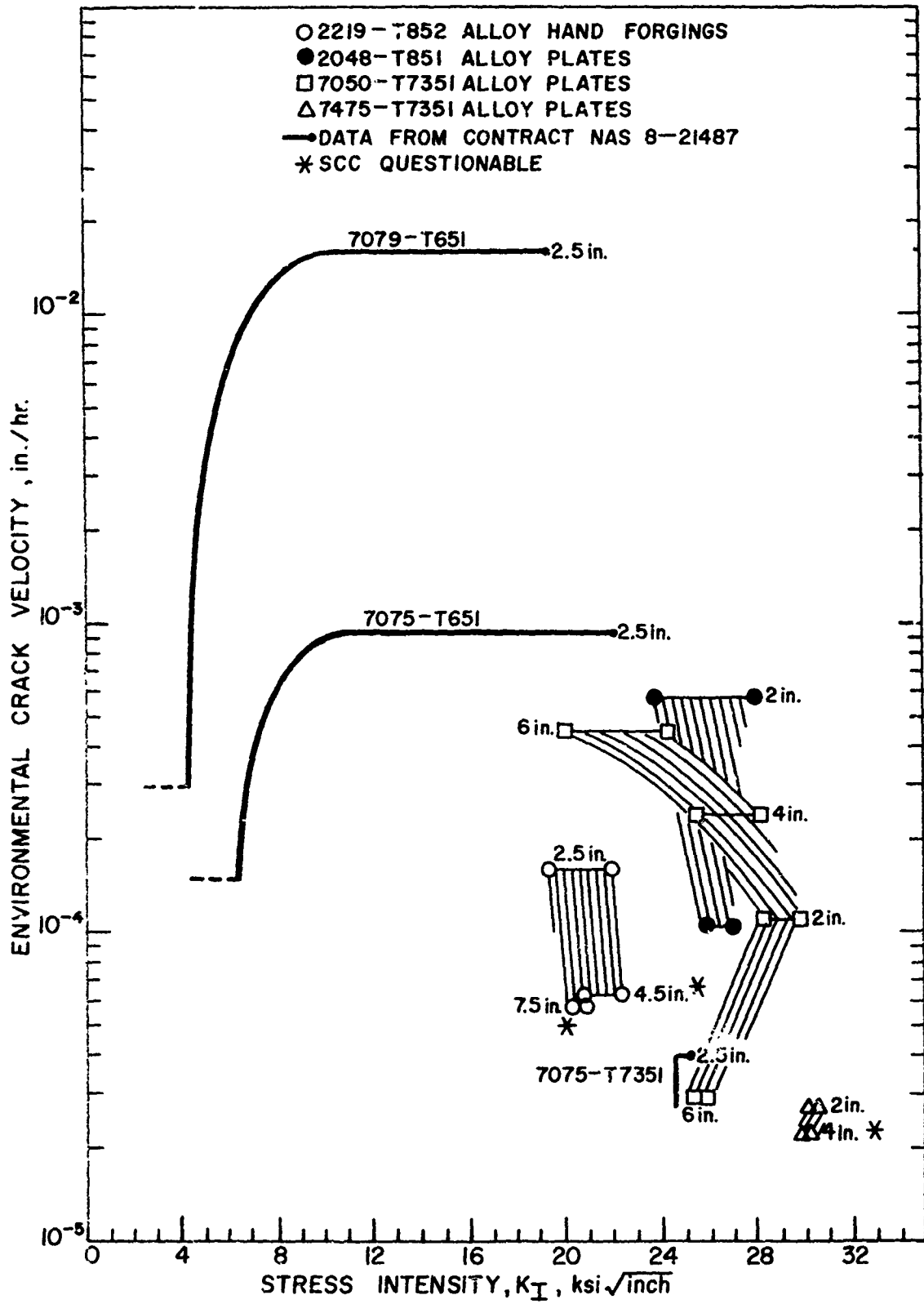

Fig. 74 K-Rate Comparisons of the Materials

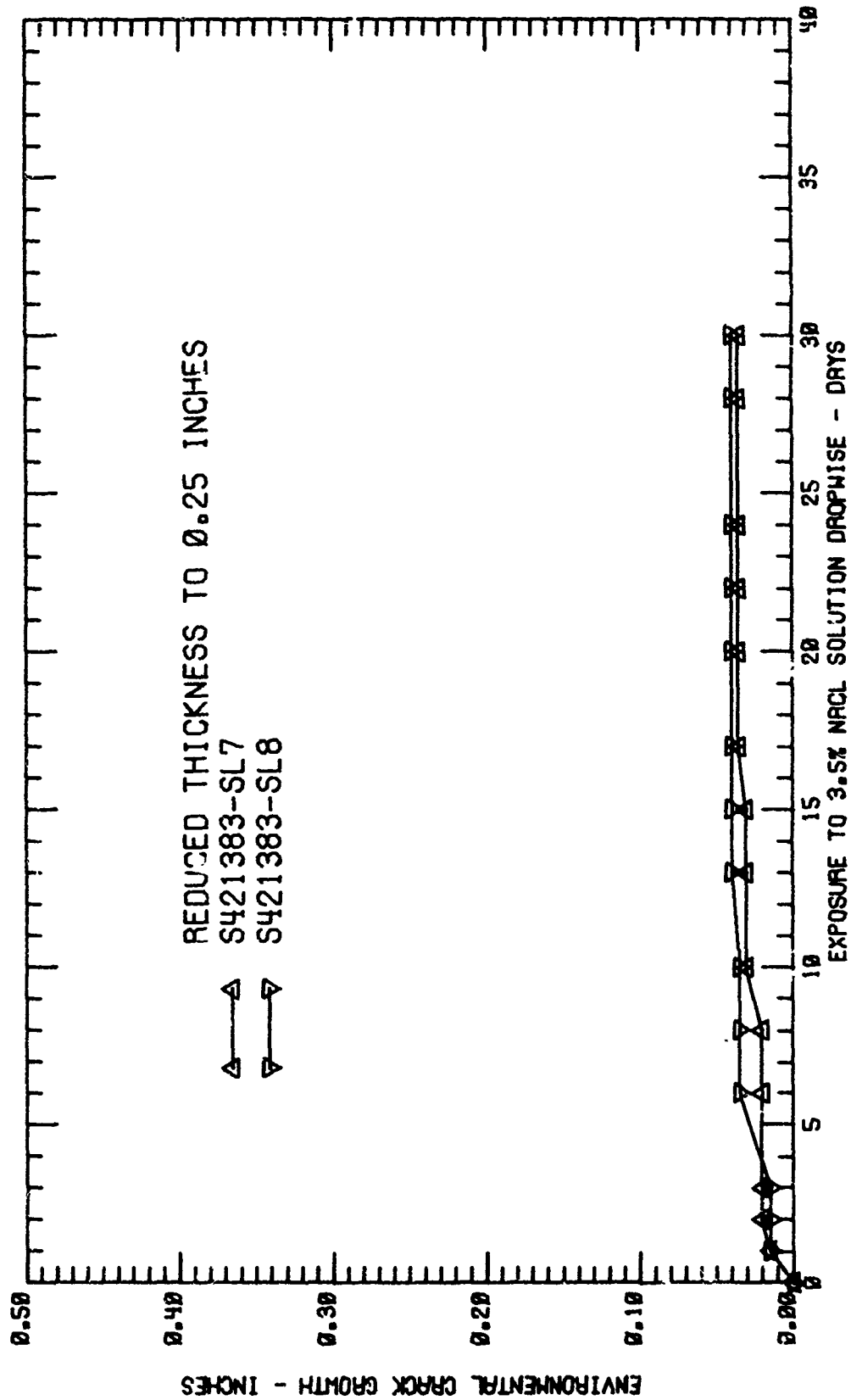

Fig. 75 ENVIRONMENTAL CRACK GROWTH OF SHORT TRANSVERSE 2048-T851 ALLOY
DCR SPECIMENS REMOVED FROM A 4-INCH THICK PLATE.

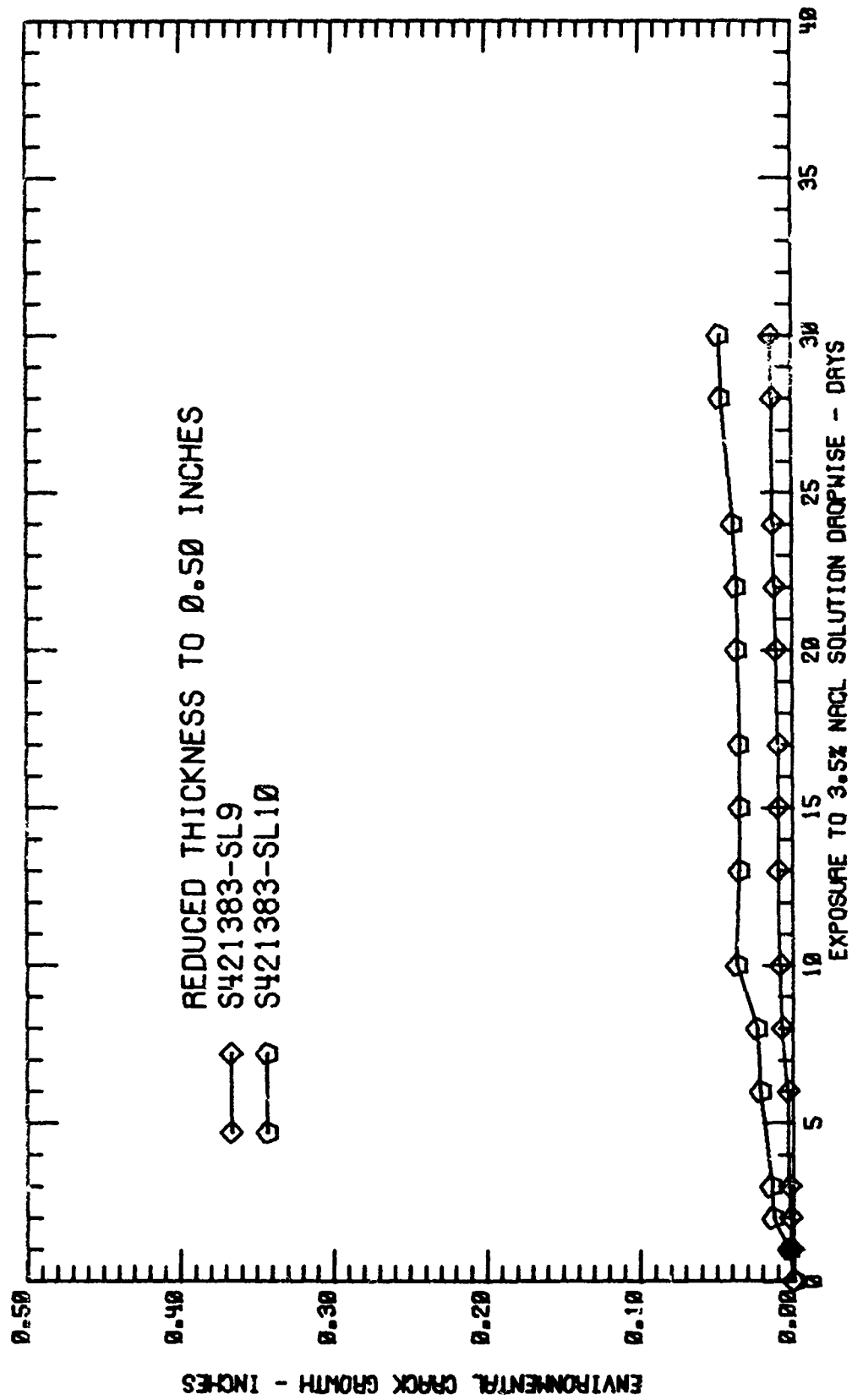

Fig. 76 ENVIRONMENTAL CRACK GROWTH OF SHORT TRANSVERSE 2048-T851 ALLOY
DCB SPECIMENS REMOVED FROM A 4-INCH THICK PLATE.

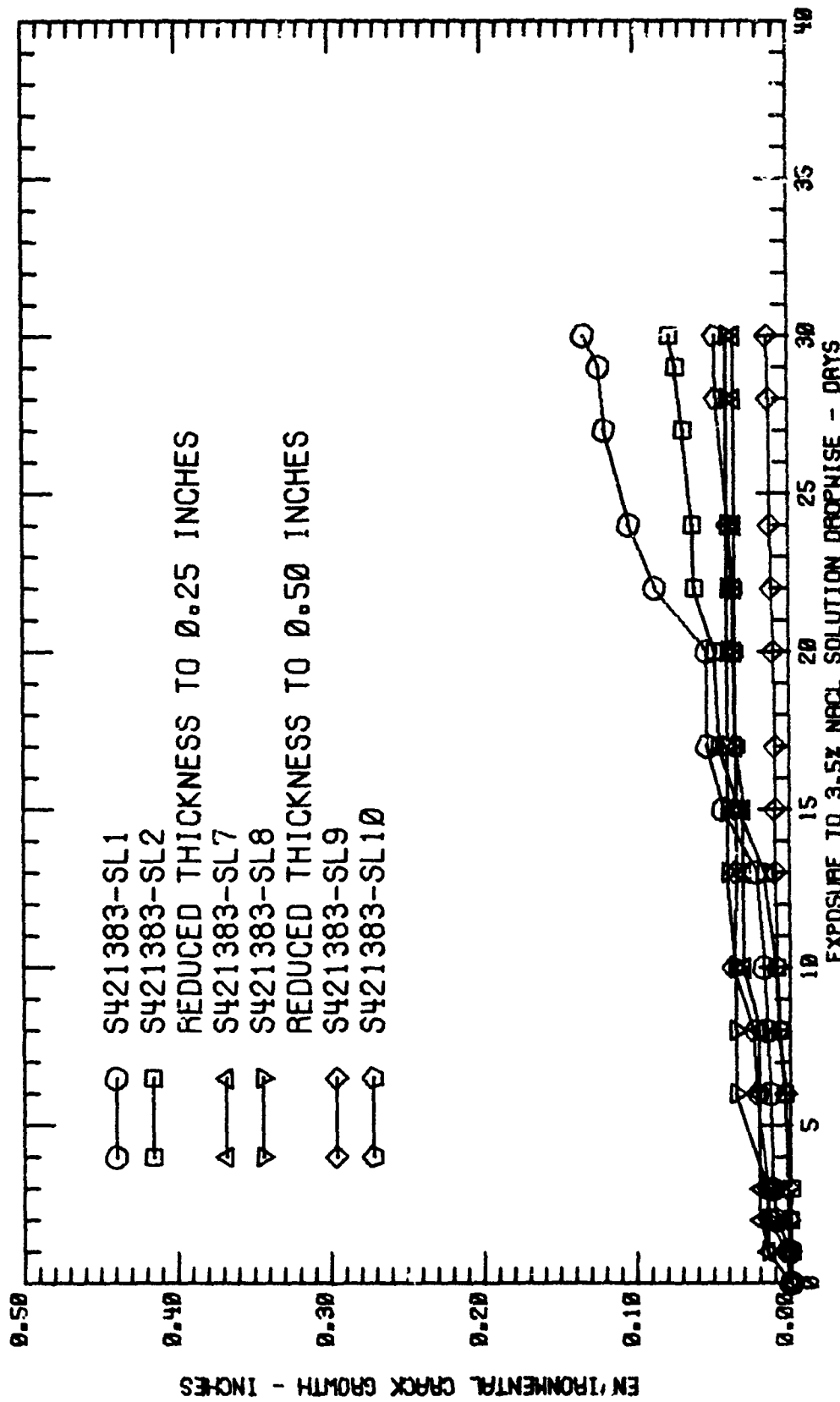

FIG. 77 ENVIRONMENTAL CRACK GROWTH OF SHORT TRANSVERSE 2048-T851 ALLOY DCB SPECIMENS REMOVED FROM A 4-INCH THICK PLATE.

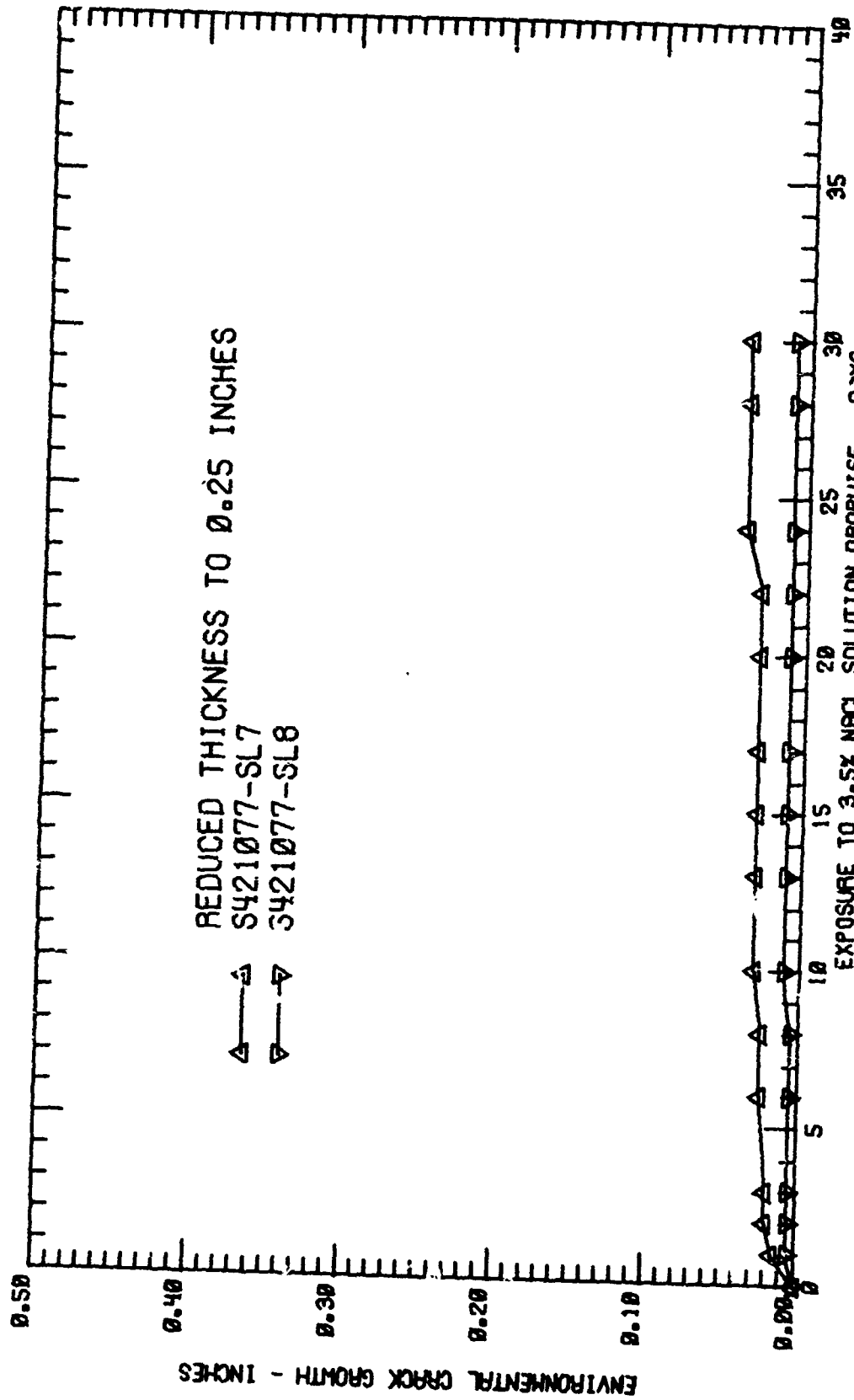

FIG. 78 ENVIRONMENTAL CRACK GROWTH OF SHORT TRANSVERSE 7050-T7351 ALLOY DCB SPECIMENS REMOVED FROM A 4-INCH THICK PLATE.

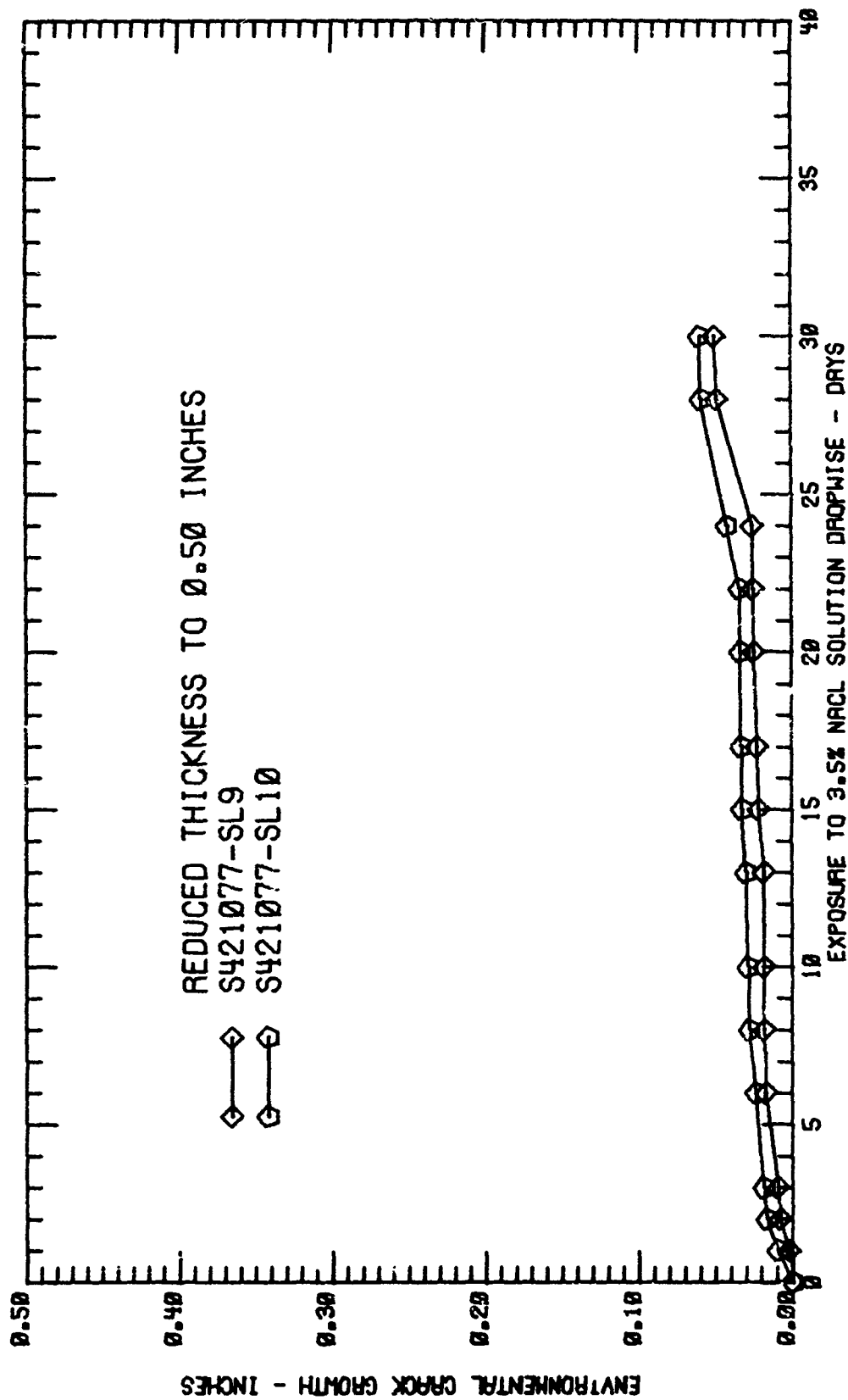

Fig. 79 ENVIRONMENTAL CRACK GROWTH OF SHORT TRANSVERSE 7050-T7351 ALLOY DCB SPECIMENS REMOVED FROM A 4-INCH THICK PLATE.

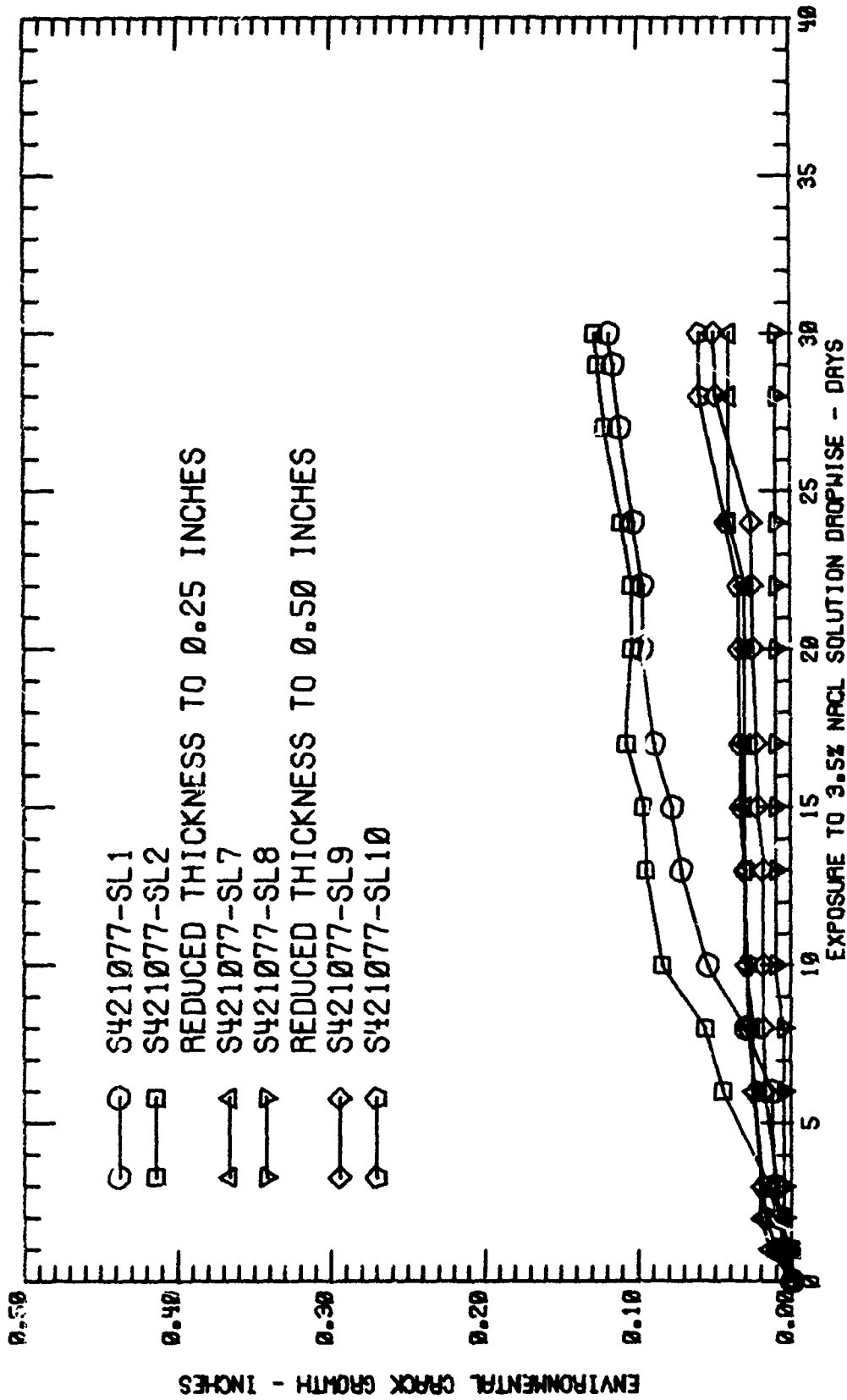

FIG. 80 ENVIRONMENTAL CRACK GROWTH OF SHORT TRANSVERSE 7050-T7351 ALLOY DCB SPECIMENS REMOVED FROM A 4-INCH THICK PLATE.

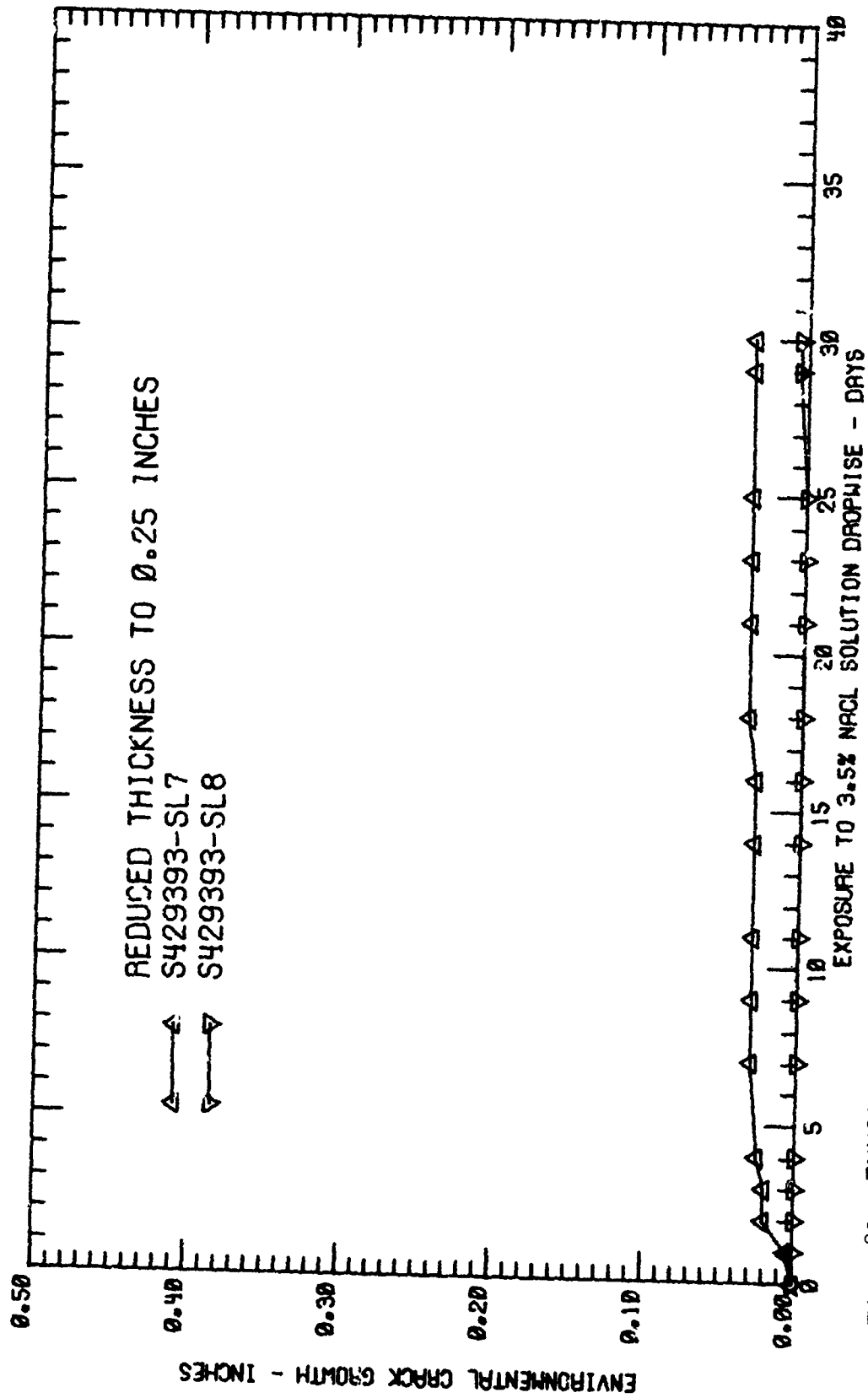

FIG. 81 ENVIRONMENTAL CRACK GROWTH OF SHORT TRANSVERSE 7475-T7351 ALLOY DCB SPECIMENS REMOVED FROM A 4-INCH THICK PLATE.

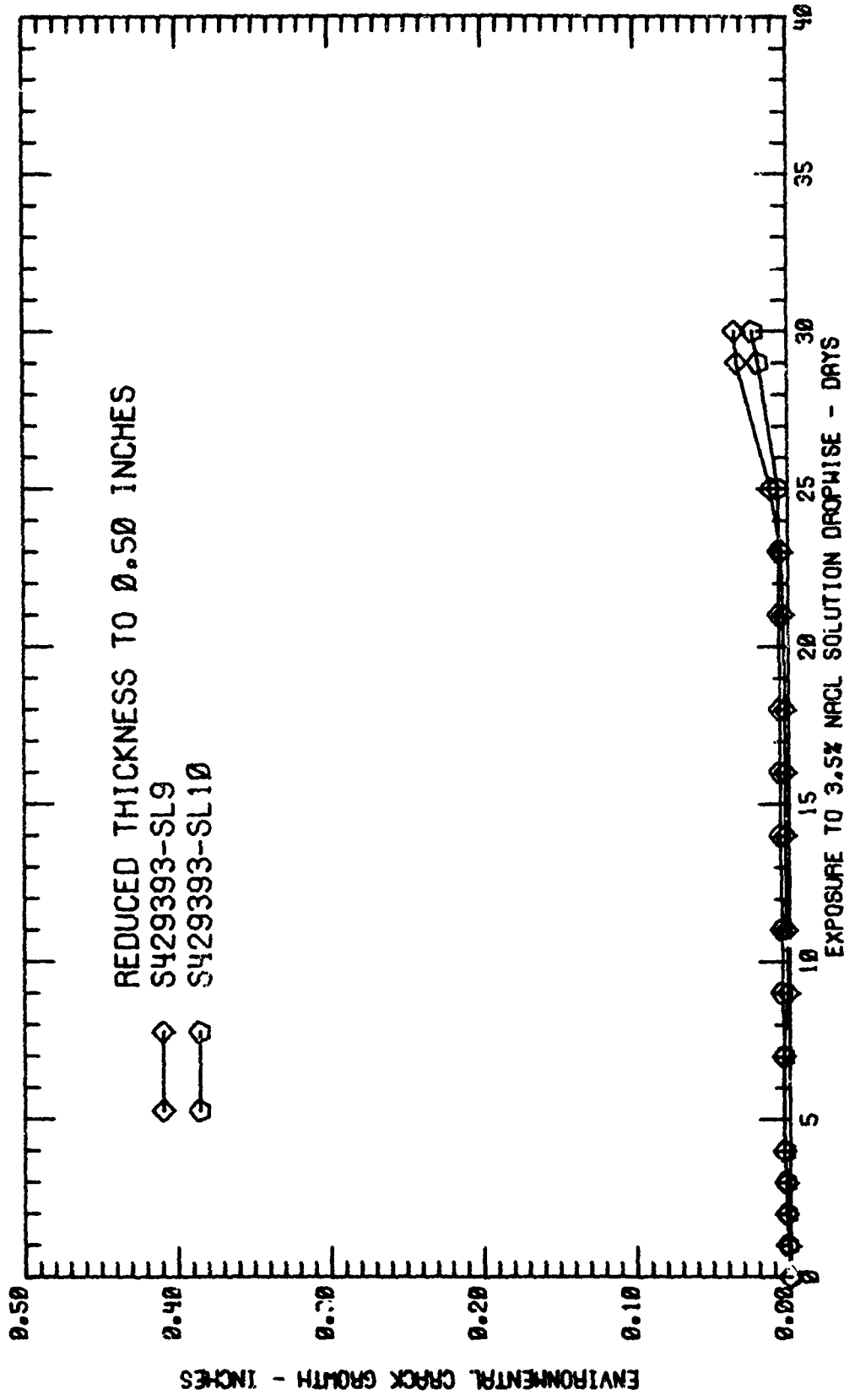

FIG. 82 ENVIRONMENTAL CRACK GROWTH OF SHORT TRANSVERSE 7475-T7351 ALLOY DCB SPECIMENS REMOVED FROM A 4-INCH THICK PLATE.

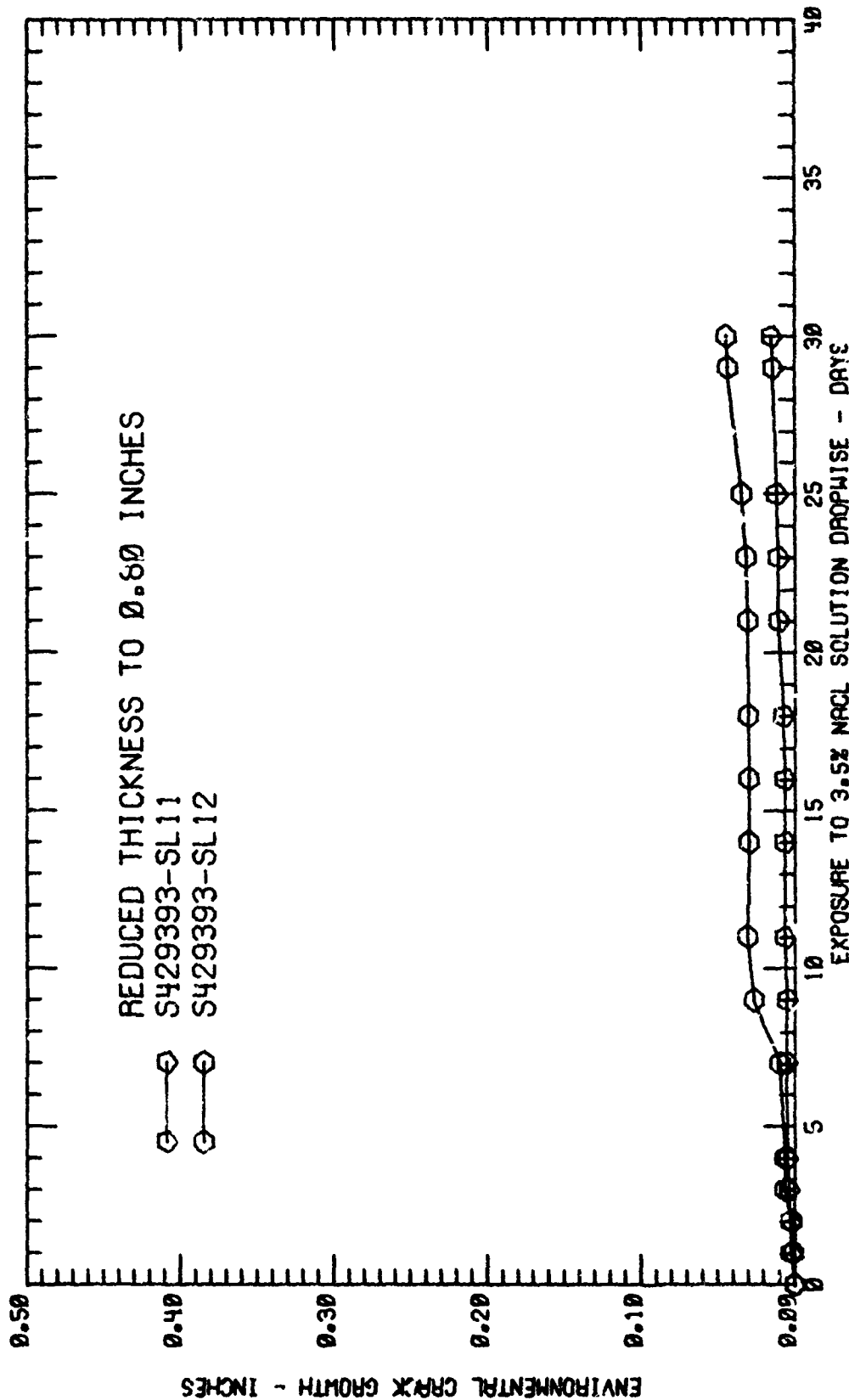

Fig. 83 ENVIRONMENTAL CRACK GROWTH OF SHORT TRANSVERSE 7475-T7351 ALLOY DCB SPECIMENS REMOVED FROM A 4-INCH THICK PLATE.

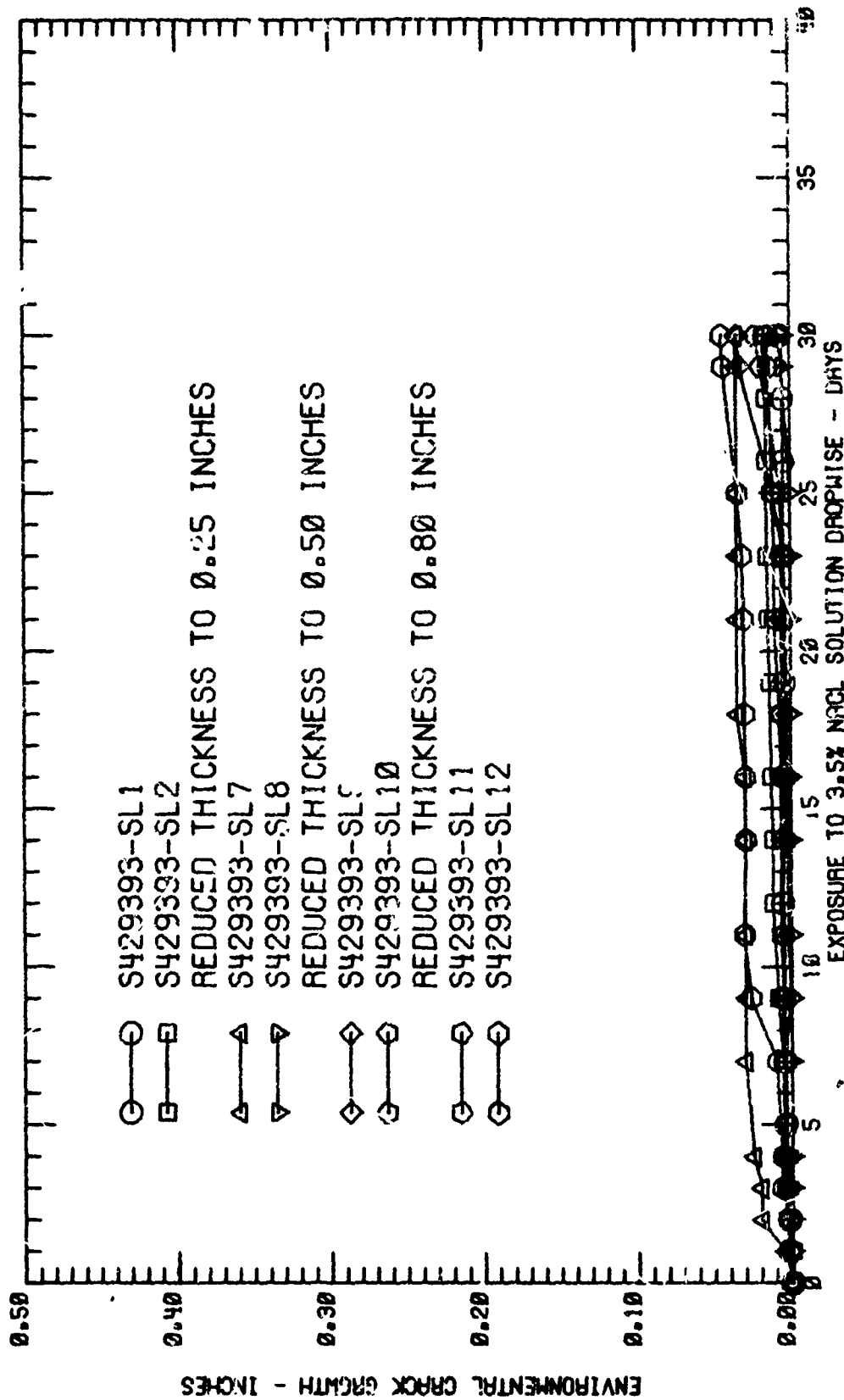

FIG. 84 ENVIRONMENTAL CRACK GROWTH OF SHORT TRANSVERSE 7475-T7351 ALLOY DCB SPECIMENS REMOVED FROM A 4-INCH THICK PLATE.

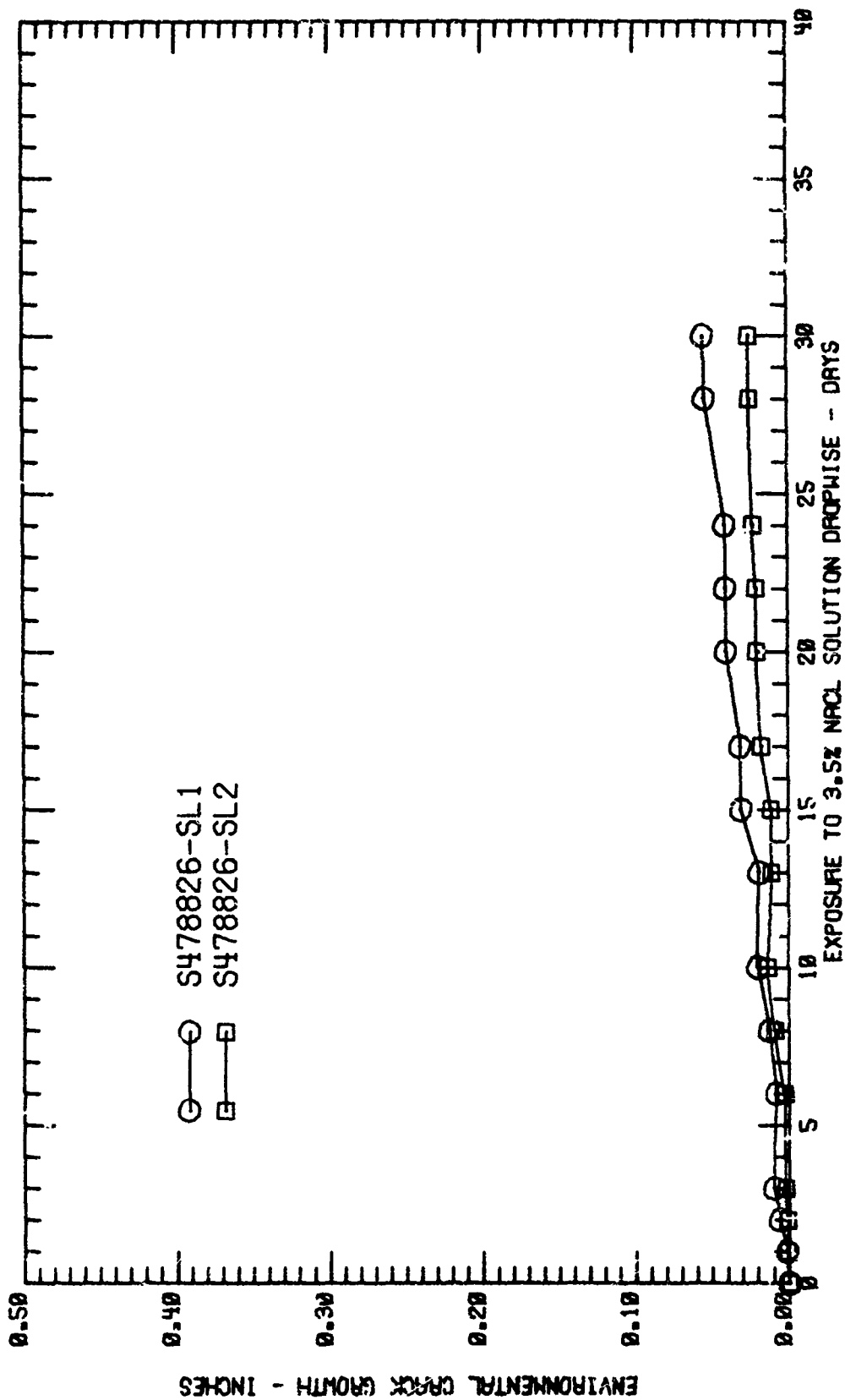

Fig. 85 ENVIRONMENTAL CRACK GROWTH OF SHORT TRANSVERSE 7475-T7351 ALLOY DCB SPECIMENS REMOVED FROM A 2.25-INCH THICK PLATE.

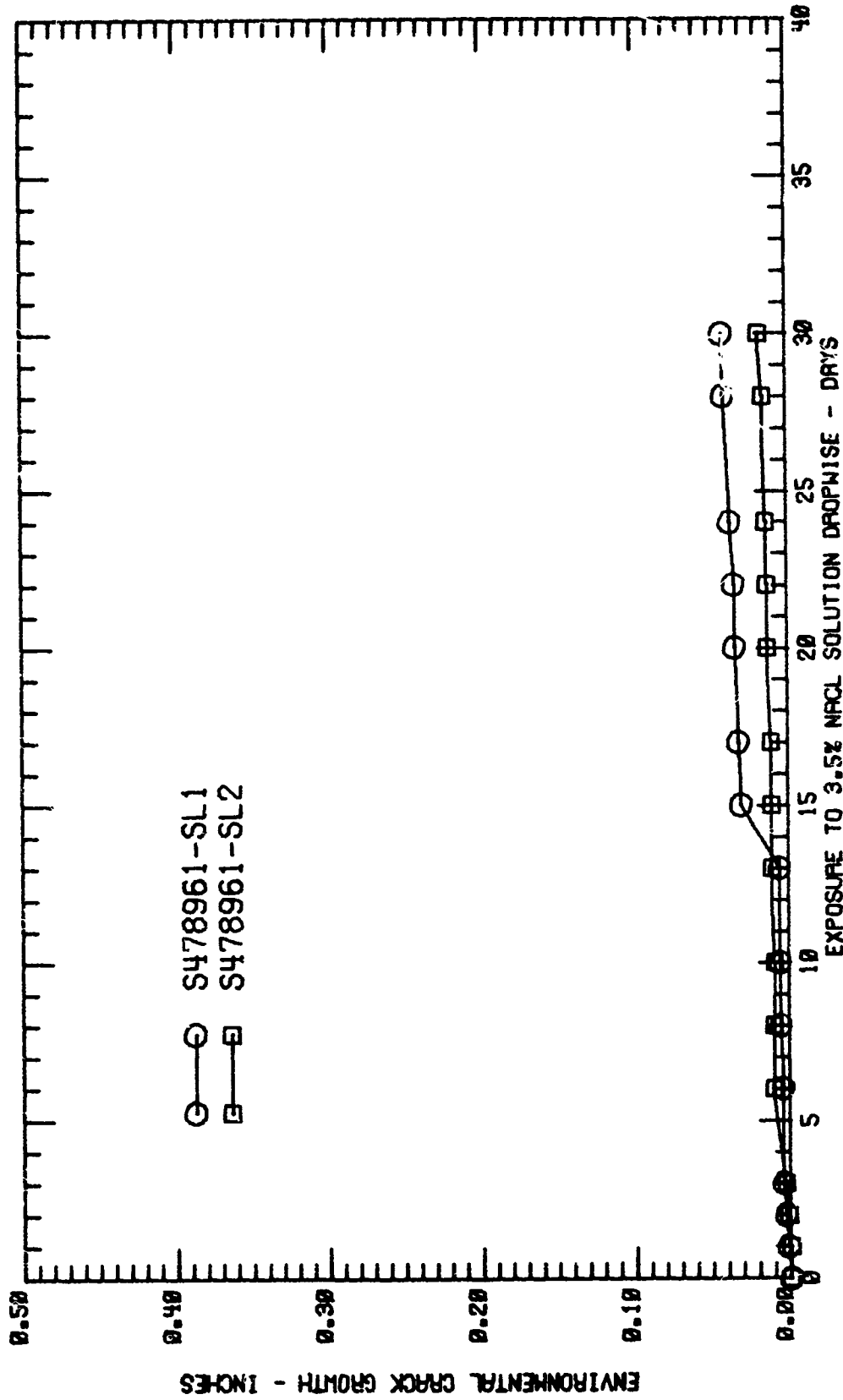

FIG. 86 ENVIRONMENTAL CRACK GROWTH OF SHORT TRANSVERSE 7475-T7351 ALLOY DCB SPECIMENS REMOVED FROM A 3.5 INCH THICK PLATE.

TABLE 1

CHEMICAL COMPOSITIONS OF 2048-T851 PLATE
(F33615-74-C-5089)

Sample (a) Thickness, Number in.	Element, %									
	Si	Fe	Cu	Mn	Mg	Cr	Zn	Ti		
0.500	0.05	0.13	3.12	0.40	1.34	0.00	0.05	0.01		
0.500	0.05	0.12	3.30	0.37	1.25	0.00	0.05	0.01		
1.000	0.05	0.12	3.74	0.37	1.38	0.00	0.06	0.01		
1.000	0.05	0.13	3.15	0.40	1.31	0.00	0.05	0.01		
2.000	0.05	0.13	3.21	0.40	1.29	0.00	0.05	0.01		
2.000	0.06	0.13	3.51	0.38	1.27	0.00	0.05	0.01		
3.000	0.08	0.15	3.24	0.34	1.25	0.00	0.02	0.01		
3.000	0.06	0.13	3.63	0.29	1.32	0.00	0.02	0.01		
4.000	0.05	0.13	3.19	0.40	1.35	0.00	0.05	0.01		
4.000	0.06	0.13	3.62	0.40	1.25	0.00	0.05	0.01		
Limits (b) (Maximum unless range is shown)	0.15	0.20	2.8-3.8	0.20-0.6	1.2-1.8	--	0.25	0.10		

(a) All samples fabricated by Reynolds Metals Co.

(b) Aluminum Association Alloy Designations and Chemical Composition Limits For Wrought Aluminum Alloys, revised September 1976.

TABLE 2

 CHEMICAL COMPOSITIONS OF 7050-T7351 PLATE
 (F33615-74-C-5089)

Sample (a) Thickness, Number in.	Element, %									
	Si	Fe	Cu	Mn	Mg	Cr	Zn	Ti	Zr	
2.000 421074	0.04	0.07	2.31	0.00	2.24	0.00	6.05	0.04	0.11	
2.000 421075	0.03	0.07	2.32	0.00	2.21	0.00	6.20	0.03	0.10	
3.000 421076	0.03	0.07	2.41	0.00	2.27	0.00	6.07	0.02	0.11	
3.000 421081	0.03	0.06	2.35	0.00	2.22	0.00	5.96	0.02	0.11	
4.000 421077	0.03	0.07	2.48	0.00	2.27	0.00	6.45	0.02	0.11	
4.000 421078	0.03	0.07	2.41	0.00	2.22	0.00	6.19	0.02	0.11	
5.000 421073	0.04	0.07	2.36	0.00	2.23	0.00	6.18	0.03	0.10	
5.118 421278	0.06	0.09	2.21	0.00	2.11	0.00	6.09	0.06	0.10	
6.000 421079	0.04	0.08	2.34	0.00	2.13	0.00	6.27	0.04	0.11	
6.000 421080	0.03	0.07	2.43	0.00	2.34	0.00	6.24	0.02	0.11	
Limits (b) (Maximum unless range is shown)	0.12	0.15	2.0-2.6	0.10	1.9-2.6	0.04	5.7-6.7	0.06	0.08-0.15	

(a) All samples fabricated by Alcoa.

(b) Aluminum Association Alloy Designations and Chemical Composition Limits For Wrought Aluminum Alloys, revised September 1976.

TABLE 3

CHEMICAL COMPOSITIONS OF 7475-T7351 PLATE
(F33615-74-C-5089)

Sample (a)		Element, %								
Thickness, in.	Number	Si	Fe	Cu	Mn	Mg	Cr	Ni	Zn	Ti
0.500	429422	0.03	0.10	1.47	0.00	2.19	0.19	0.00	5.46	0.02
0.500	429423	0.03	0.09	1.38	0.00	2.16	0.19	0.00	5.54	0.02
1.000	429387	0.03	0.10	1.55	0.00	2.18	0.20	0.00	5.48	0.02
1.000	429388	0.04	0.09	1.42	0.00	2.15	0.20	0.00	5.61	0.02
2.000	429389	0.03	0.10	1.60	0.00	2.22	0.20	0.00	5.56	0.02
2.000	429390	0.04	0.10	1.45	0.00	2.16	0.20	0.00	5.57	0.02
3.000	429391	0.04	0.10	1.48	0.00	2.20	0.20	0.00	5.67	0.02
3.000	429392	0.03	0.10	1.51	0.00	2.15	0.20	0.00	5.45	0.02
4.000	429393	0.04	0.11	1.48	0.00	2.19	0.20	0.00	5.69	0.02
4.000	429394	0.03	0.10	1.54	0.00	2.16	0.20	0.00	5.44	0.02
<u>Current Practice</u>										
0.500	478717	0.05	0.07	1.55	0.00	2.19	0.20	0.00	5.60	0.02
0.750	478718	0.05	0.07	1.54	0.00	2.16	0.19	0.00	5.49	0.02
1.750	478824	0.06	0.09	1.61	0.00	2.38	0.21	0.01	5.91	0.02
1.750	478825	0.06	0.09	1.65	0.00	2.33	0.20	0.00	5.79	0.02
2.250	478826	0.06	0.09	1.63	0.00	2.27	0.20	0.00	5.74	0.02
2.250	478827	0.06	0.08	1.66	0.00	2.37	0.20	0.00	5.87	0.02
2.750	478828	0.06	0.08	1.57	0.00	2.24	0.20	0.00	5.60	0.02
2.750	478829	0.06	0.08	1.60	0.00	2.34	0.20	0.00	5.81	0.02
3.500	478830	0.06	0.09	1.62	0.00	2.30	0.20	0.00	5.73	0.02
3.500	478961	0.06	0.10	1.51	0.00	2.31	0.21	0.00	5.64	0.03
Limits	(b) (Maximum unless range is shown)	0.10	0.12	1.2-1.9	0.06	1.9-2.6	0.18-0.25	--	5.2-6.2	0.06

(a) All samples fabricated by Alcoa.

(b) Aluminum Association Alloy Designations and Chemical Composition Limits For Wrought Aluminum Alloys, revised September 1976.

TABLE 4
 CHEMICAL COMPOSITIONS OF 2219-T852 HAND FORGINGS
 (F33615-74-C-5089)

Sample (a) Dimensions, in.	Sample Number	Element, %									
		Si	Fe	Cu	Mn	Mg	Zn	Ti	Zr	V	
2.0x8	429246	0.08	0.19	6.33	0.28	0.00	0.00	0.07	0.12	0.08	
2.5x22	478817	0.07	0.16	6.66	0.25	0.00	0.02	0.09	0.14	0.08	
3.5x14	429512	0.08	0.18	6.35	0.26	0.00	0.01	0.08	0.11	0.09	
3.5x22	429513	0.05	0.18	6.32	0.28	0.00	0.07	0.07	0.12	0.10	
4.5x22	429249	0.07	0.13	6.04	0.29	0.00	0.01	0.10	0.12	0.09	
4.5x22	429514	0.05	0.18	6.36	0.27	0.00	0.06	0.06	0.13	0.10	
5.5x22	429247	0.05	0.19	6.40	0.30	0.00	0.07	0.06	0.12	0.09	
5.5x22	429248	0.08	0.15	6.11	0.25	0.00	0.01	0.08	0.12	0.09	
7.5x22	429244	0.08	0.15	6.11	0.25	0.00	0.01	0.09	0.12	0.10	
7.5x22	429245	0.05	0.17	5.95	0.25	0.00	0.05	0.06	0.13	0.09	
Limits (b) (Maximum unless range is shown)		0.20	0.30	5.8-6.8	0.20-0.40	0.02	0.10	0.02-0.10	0.10-0.25	0.05-0.15	

(a) All samples fabricated by Alcoa.

(b) Aluminum Association Alloy Designations and Chemical Composition Limits for Wrought Aluminum Alloys, revised September 1976.

TABLE 5
MECHANICAL PROPERTIES OF 2048-T851 PLATINUM
(F33615-74-C-5089)

Sample Thickness, in.	Sample Number	Direction (b)	Tensile			Reduction in Area, %	Compressive Yield Strength, ksi	Shear Ultimate Strength, ksi	Bearing (Plattise)		Ultimate Strength, ksi	Yield Strength, ksi
			Ultimate Strength, ksi	Yield Strength, (a) ksi	Elongation in 4D, %				Strength, e/D=1.5	Strength, e/D=2.0		
0.500	421378	L	66.1	62.2	12.0	38	63.4	38.8	100.3	132.0	87.6	100.8
		LT	66.3	61.5	12.0	38	63.4	39.1	102.3	132.9	92.3	101.4
0.500	421379	L	68.1	63.8	12.0	39	64.7	40.0	105.4	136.2	92.9	107.0
		LT	68.4	63.2	11.0	34	65.4	40.1	103.4	135.1	90.5	102.7
1.000	421108	L	71.4	67.5	8.5	27	66.5	40.7	101.4	131.8	89.6	101.6
		LT	70.5	65.4	8.5	20	66.5	39.8	102.3	134.4	90.5	103.2
1.000	421380	L	65.3	62.1	12.0	41	60.4	38.6	97.5	126.1	85.5	99.8
		LT	66.1	61.1	7.5	18	61.3	38.2	98.6	126.7	87.3	100.9
2.000	421381	L	67.3	63.7	11.5	36	62.3	38.0	99.7	129.5	87.4	100.4
		LT	67.1	62.6	7.0	10	63.3	39.2	100.6	131.1	90.7	101.2
2.000	421382	LT	64.0	59.3	5.4	10	64.4	--	--	--	--	--
		ST	69.6	67.4	11.0	32	63.4	40.9	105.5	136.1	92.0	104.2
3.000	421083	L	69.9	64.9	7.5	16	64.7	40.7	104.4	135.4	91.4	103.9
		LT	65.7	59.9	6.2	12	64.5	--	--	--	--	--
3.000	421084	L	67.9	64.2	8.5	20	60.9	38.6	101.1	131.5	88.6	104.0
		LT	68.0	62.9	7.0	16	63.0	38.6	96.7	130.9	87.1	102.1
3.000	421084	LT	63.6	58.5	4.0	8	62.9	33.1	--	--	--	--
		ST	70.2	64.7	6.5	11	62.9	40.2	98.0	132.5	87.8	104.5
4.000	421383	L	64.4	59.1	9.0	22	55.9	37.4	100.6	132.0	90.1	107.3
		LT	63.7	57.3	7.5	12	56.6	40.0	--	--	--	--
4.000	421384	LT	62.5	56.0	4.3	8	59.5	34.2	95.1	122.9	81.2	94.9
		ST	69.2	64.2	8.0	16	60.9	40.2	96.6	125.4	82.6	96.8
2.001-3.000		L	62	56	6	--	--	--	--	--	--	--
		LT	62	56	5	--	--	--	--	--	--	--
0.500		LT	60	54	2.5	--	--	--	--	--	--	--
		ST	68	62	10	--	--	--	--	--	--	--
1.000		LT	68	61	8	--	--	--	--	--	--	--
		ST	68	61	6	--	--	--	--	--	--	--
2.000		LT	67	60	6	--	--	--	--	--	--	--
		ST	66	59	6	--	--	--	--	--	--	--
3.000		LT	66	59	6	--	--	--	--	--	--	--
		ST	66	59	6	--	--	--	--	--	--	--
4.000		LT	66	59	6	--	--	--	--	--	--	--
		ST	66	59	6	--	--	--	--	--	--	--

Tentative Minimum Properties

Typical Properties (d)

(a) Offset equals 0.2 per cent.
 (b) L-Longitudinal; LT-Long-Transverse; ST-Short-Transverse.
 (c) Offset equals 2 per cent of pin diameter.
 (d) Minimum properties expected. 5 to 6 ksi below typical values; values supplied by Reynolds.

TABLE 6
MECHANICAL PROPERTIES OF 7050-T7351 PLATE
(F33615-74-C-5089)

Sample Thickness, In.	Sample Number	Direction (b)	Tensile		Elongation in 4D, in. %	Reduction in Area, %	Compressive Yield Strength, ksi	Shear Ultimate Strength, ksi	Bearing (Flatwise)		Ultimate Strength, ksi		Yield Strength, (c) ksi	
			Ultimate Strength, ksi	Yield Strength, (a) ksi					$\frac{e}{D=2.0}$	$\frac{e}{D=1.5}$	$\frac{e}{D=2.0}$	$\frac{e}{D=1.5}$		
2.000	421074	L	71.8	61.1	13.5	33	59.4	43.6	122.3(d)	101.5(d)	108.0(d)	91.5(d)	108.0(d)	
		LT	72.1	60.2	12.0	70	63.3	43.3	141.3	93.2	109.0	93.2	109.0	
2.000	421075	LT	68.9	55.6	7.8	12	62.9	---	---	---	---	---	---	
		ST	71.3	60.4	14.0	35	59.0	43.6	142.8(e)	90.1(e)	107.6(e)	90.3	109.0	
3.000	421076	L	71.6	60.4	12.0	29	62.6	43.2	142.5	90.3	109.0	90.3	109.0	
		ST	69.0	55.3	6.6	16	62.4	---	---	---	---	---	---	
3.000	421081	L	73.5	63.7	12.0	28	61.4	45.3	146.3	91.8	107.3	91.8	107.3	
		LT	74.2	63.7	10.5	19	66.2	45.2	147.6	95.0	114.8	95.0	114.8	
3.000	421081	LT	71.9	60.1	6.5	12	65.0	42.7	---	---	---	---	---	
		ST	73.4	63.9	12.5	29	61.7	45.6	147.6	93.9	111.3	93.9	111.3	
4.000	421077	L	74.7	64.2	10.5	11	68.6	43.1	142.8	92.9	112.0	92.9	112.0	
		ST	72.4	61.4	6.5	12	65.6	43.2	---	---	---	---	---	
4.000	421077	L	73.1	63.7	10.0	30	60.6	45.6	142.2	92.5	107.5	92.5	107.5	
		LT	74.4	63.4	10.0	16	66.0	45.2	146.7	93.3	110.4	93.3	110.4	
4.000	421078	LT	72.4	60.0	7.8	12	64.9	41.9	---	---	---	---	---	
		ST	72.9	63.7	11.5	24	60.5	45.5	145.9	94.6	111.3	94.6	111.3	
5.000	421073	L	74.2	63.4	10.0	16	66.0	45.3	145.8	97.8	111.2	97.8	111.2	
		ST	71.6	59.0	5.7	8	64.3	41.7	---	---	---	---	---	
5.118	421278	L	72.5	63.7	11.5	24	59.4	44.9	142.2(e)	91.5(e)	113.8	91.5(e)	113.8	
		LT	74.1	63.7	10.0	18	65.1	44.9	144.2(d)	90.1	110.0(d)	90.1	110.0(d)	
6.000	421079	L	70.3	58.8	6.0	10	63.4	41.4	---	---	---	---	---	
		LT	71.9	63.2	11.0	22	59.8	44.6	141.8	91.3	107.2	91.3	107.2	
6.000	421079	LT	74.4	61.4	9.0	15	64.9	44.5	142.7	91.4	109.0	91.4	109.0	
		ST	69.5	58.6	7.0	10	62.5	42.2	---	---	---	---	---	
6.000	421080	L	69.8	60.4	11.0	21	56.3	43.3	142.8	89.0	107.6(e)	89.0	107.6(e)	
		LT	70.6	59.1	10.0	16	61.7	43.1	143.6	90.7	110.8	90.7	110.8	
6.000	421080	LT	68.0	56.3	6.2	8	60.4	41.1	---	---	---	---	---	
		ST	71.8	62.2	10.5	19	57.7	44.9	143.2(d)	91.0(d)	110.2(d)	91.0(d)	110.2(d)	
7.000	421080	L	72.9	60.9	9.0	13	63.8	44.7	143.4(d)	93.0	106.6(d)	93.0	106.6(d)	
		ST	68.5	58.1	4.0	6	62.7	41.4	---	---	---	---	---	
2.000	2.000	L	67	58	10	10	58	49	Tentative Minimum Properties					
		LT	66	58	7	7	58	49						
2.001-3.000	2.001-3.000	L	67	59	10	10	59	49						
		LT	66	59	7	7	59	49						
3.001-4.000	3.001-4.000	L	64	55	2.5	2.5	55	49						
		LT	66	57	10	10	57	49						
4.001-5.000	4.001-5.000	L	67	57	7	7	57	49						
		LT	63	53	2.5	2.5	53	49						
5.001-6.000	5.001-6.000	L	64	55	10	10	55	49						
		LT	67	57	2.5	2.5	57	49						
5.001-6.000	5.001-6.000	L	62	53	9	9	53	49						
		LT	63	53	5	5	53	49						
5.001-6.000	5.001-6.000	L	59	49	2.5	2.5	49	49						
		LT	62	53	9	9	53	49						

(a) Offset equals 0.2 per cent.
 (b) L - Longitudinal, LT - Long-Transverse; ST - Short-Transverse; Specification test location at T/4.
 (c) Offset equals 2 per cent of pin diameter.
 (d) Test value; original test result questionable.
 (e) Average of original test and retest values.
 NOTE: All samples fabricated by Alcoa.

TABLE 7
MECHANICAL PROPERTIES OF 7475-T7351 PLATE
(F39619-74-C-5089)

Sample Thickness, in.	Sample Number	Direction (b)	Ultimate Strength, ksi	Yield Strength, (a) ksi	Tensile		Compressive Yield (a) strength, ksi	Shear Ultimate Strength, ksi	Bearing (Flatwise)	
					Elongation, in %	Reduction in Area, %			Ultimate Strength, ksi	Yield Strength, (c) ksi
0.500	429422	L (d)	72.4	62.4	16.0	41	62.5	44.6	106.0	86.2
		L (d)	71.1	61.6	16.0	39	--	--	137.4	107.7
		ST	73.7	63.2	13.5	33	65.2	43.5	105.3	86.4
0.500	429423	L (d)	72.2	62.3	16.0	42	63.4	45.1	106.9	86.2
		L (d)	74.0	63.9	17.0	43	--	--	138.8	104.7
		ST	73.3	63.1	14.0	27	64.8	44.4	106.8	84.0
1.000	429387	L	72.5	62.3	14.2	39	61.6	42.8	103.3	83.6
		ST	71.6	61.2	13.2	32	62.7	42.3	103.3	83.8
1.000	429388	L	70.0	59.6	15.0	41	58.3	42.1	102.0	81.9
		ST	70.0	59.4	13.5	32	61.1	41.6	102.4	82.6
2.000	429389	L (d)	68.0	57.0	15.2	41	56.0	42.5	106.1	82.2
		L	68.7	57.4	13.5	38	60.3	42.5	106.8	82.6
		ST	69.3	58.1	13.0	27	60.3	42.5	106.8	82.6
2.000	429390	L (d)	65.5	57.0	6.2	16	59.8	42.5	108.6	89.3
		L	68.7	57.7	15.0	38	57.1	(e)	107.3	87.3
		ST	68.7	57.6	15.5	38	--	--	137.2	87.6
3.000	429391	L (d)	69.5	58.3	13.5	27	60.1	42.5	107.5	86.1
		L	66.6	58.2	7.8	17	60.7	--	136.3	86.1
		ST	65.7	54.9	15.7	42	54.3	43.2	104.0	83.8
3.000	429392	L (d)	67.8	55.7	11.7	27	58.9	43.0	106.1	85.2
		L	67.0	54.4	8.0	17	56.3	40.5	106.1	85.2
		ST	65.8	54.0	15.5	41	54.0	43.2	104.5	84.3
4.000	429393	L (d)	66.2	54.4	11.2	20	58.8	43.2	105.3	85.2
		L	63.8	52.6	7.0	11	56.3	40.0	105.3	85.2
		ST	66.0	54.2	11.0	21	51.2	41.2	100.3	80.5
4.000	429394	L (d)	65.0	52.5	8.2	13	56.3	39.1	100.1	81.4
		L	64.1	52.7	15.2	41	50.9	41.6	100.9	80.5
		ST	65.8	53.1	10.7	19	55.3	41.6	99.9	80.5
0.500-1.000	L	L	68	57	10	10	55.8	38.9	100.3	80.5
		ST	68	57	9	9	55.8	38.9	100.3	80.5
		ST	67	55	10	10	55.8	38.9	100.3	80.5
1.501-2.000	L	L	67	55	8	8	55.8	38.9	100.3	80.5
		ST	67	55	8	8	55.8	38.9	100.3	80.5
		ST	64	52	4	4	55.8	38.9	100.3	80.5
2.501-3.000	L	L	65	53	10	10	55.8	38.9	100.3	80.5
		ST	65	53	3	3	55.8	38.9	100.3	80.5
		ST	62	50	3	3	55.8	38.9	100.3	80.5
3.501-4.000	L	L	61	48	9	9	55.8	38.9	100.3	80.5
		ST	61	48	7	7	55.8	38.9	100.3	80.5
		ST	59	46	7	7	55.8	38.9	100.3	80.5

(a) Offset equals 0.2 per cent. Transverse, ST - Short-Transverse. Specification test location T/2 for 0.500 and 1.000-in. thickness. (b) Original values 2 per cent of pin diameter. (c) Original values 2 per cent of pin diameter. (d) Original values 2 per cent of pin diameter. (e) Original values 2 per cent of pin diameter.

NOTE 1: Table 17, compressive and shear ratios based on original LT tensile tests except as noted in (e). Where a bearing retest is indicated, ratio is based on average of original test and retest bearing and tensile properties.

NOTE 2: All samples fabricated by Alcoa.

TABLE 8

MECHANICAL PROPERTIES OF 7475-T7351 PLATE (CURRENT PRACTICE)
(M.T. NO. 110176-A)

Sample Thickness, Number Direction (b)	Ultimate Strength, ksi	Yield strength, ksi	Tensile Elongation in hr, %	Reduction in Area, %	Modulus, 10 ³ ksi	Compressive		Shear Ultimate Strength, ksi	Bearing (Flatwise)		e/15-2.0
						Yield Strength, ksi	Modulus, 10 ³ ksi		Ultimate Strength, ksi	Yield Strength, (c) ksi	
0.500 478717	L	71.0	18.0	45	---	62.3	---	43.9	142.6	145.7	114.8
	Lt	73.4	14.0	29	---	66.6	---	43.6	114.2	143.7	112.5
0.750 478718	L	73.8	16.0	46	10.32	63.4	10.69	42.6	107.7	140.3	108.3
	Lt	73.2	14.0	37	10.41	58.6	10.81	42.1	106.2	136.3	104.2
1.750 478824	L	72.9	15.5	41	---	---	---	---	---	---	---
	Lt	72.9	13.0	33	---	---	---	---	---	---	---
1.750 478825	L	72.4	15.0	41	---	---	---	---	---	---	---
	Lt	72.8	13.5	33	---	---	---	---	---	---	---
2.250 478826	L	71.1	15.5	42	---	---	---	---	---	---	---
	Lt	72.2	12.5	29	---	---	---	---	---	---	---
2.250 478827	L	70.1	15.5	40	---	---	---	---	---	---	---
	Lt	71.0	12.0	28	---	---	---	---	---	---	---
2.750 478828	L	69.0	14.5	38	---	---	---	---	---	---	---
	Lt	68.1	10.0	20	---	---	---	---	---	---	---
2.750 478829	L	68.7	15.0	48	---	---	---	---	---	---	---
	Lt	70.8	11.5	24	---	---	---	---	---	---	---
3.500 478830	L	67.0	15.0	41	---	---	---	---	---	---	---
	Lt	66.4	12.0	44	---	---	---	---	---	---	---
3.500 478961	L	66.6	15.0	39	10.13	53.8	10.48	42.5	105.9	134.6	100.4
	Lt	67.5	8.6	16	10.23	58.8	10.60	37.5	109.2	136.7	101.5
Tentative Minimum Properties											
0.500-1.000	L	68	10								
	Lt	68	9								
1.501-2.000	L	67	12								
	Lt	67	8								
2.001-2.500	L	66	10								
	Lt	66	8								
2.501-3.000	L	65	10								
	Lt	65	8								
3.001-3.500	L	63	10								
	Lt	63	8								

(a) Offset equals 0.2 per cent.
(b) L - Longitudinal, Lt - Long-Transverse, ST - Short-Transverse.
(c) Offset equals 2 per cent of pin diameter.

TABLE 9
MECHANICAL PROPERTIES OF 2-19-T852 HAND FORGINGS
(133615-74-C-5089)

Sample Dimensions, Number in.	Direction (b)	Ultimate Strength, ksi	Yield Strength, (a) ksi	Elongation in 4d, %	Reduction in Area, %	Compressive Yield Strength, (a) ksi	Shear Ultimate Strength, ksi	Heating (Edge-wise)	
								Ultimate Strength, ksi e/A = 1.5	Yield Strength, (c) ksi e/A = 1.5
2.0x8	L	65.0	50.7	10.5	26	52.5	82.7	116.2	81.5
	LT	66.6	51.5	9.4	14	53.6	84.9	120.6	84.9
2.5x22	L	64.9	50.4	13.0	32	50.5	81.5	112.5	76.2
	LT	65.9	49.9	8.0	17	52.5	85.6	118.2	78.4
3.5x14	L	65.0	50.3	11.0	26	47.8	82.2	124.3	78.3
	LT	64.4	49.8	8.0	11	48.1	89.6	117.9	76.7
3.5x22	L	65.6	51.2	10.5	24	47.5	84.0	117.0	77.1
	LT	66.7	51.1	9.0	11	47.6	81.9	113.1	77.1
4.5x22	L	59.0	45.2	12.0	28	42.3	81.8	106.2	72.3
	LT	60.3	45.7	5.0	7	44.8	84.0	114.2	72.9
4.5x22	L	64.1	50.2	12.5	29	46.8	87.1	121.8	79.1
	LT	66.6	51.2	7.9	12	48.6	89.1	119.3	80.0
5.5x22	L	65.5	49.2	11.0	25	46.8	88.2	116.4	78.9
	LT	62.3	47.2	7.1	9	47.2	90.2	117.6	78.2
5.5x22	L	60.6	44.6	14.5	22	45.9	86.9	114.2	75.7
	LT	65.8	50.8	8.6	8	44.0	90.0	116.4	75.8
7.5x22	L	54.7	41.9	12.0	26	41.4	81.1	107.0	67.4
	LT	56.7	42.4	6.5	9	42.2	81.7	108.2	67.7
7.5x22	L	57.4	43.4	11.0	26	43.8	87.4	116.7	71.9
	LT	58.3	44.1	7.5	13	43.6	87.6	114.0	74.0
up to 4,000(d)	L	62	50	6	6				
	LT	60	48	3	3				
4,001-6,000(e)	L	54	43	6	4				
	LT	54	39	3	3				
6,001-8,000(e)	L	53	40	6	4				
	LT	51	36	3	3				

Minimum Properties

(a) Offset equals 0.2%.
 (b) L-Longitudinal; LT-Long-Transverse; ST-Short-Transverse.
 (c) Offset equals 2% of pin diameter.
 (d) Federal Specification QQ-A-357B; AMIT. 1, dated May 23, 1968.
 (e) Tentative

TABLE 10
RATIOS AMONG THE TENSILE, COMPRESSIVE, SHEAR, AND BEARING PROPERTIES OF 2048-T951 PLATE
(F33615-74-C-5089)

Sample Thickness, in.	Sample Number	Compressive		Shear		Bearing (Flatwise)								
		$\frac{CVS(L)}{TYS(L)}$	$\frac{CVS(LT)}{TYS(LT)}$	$\frac{CVS(LT)}{TYS(LT)}$	$\frac{CVS(LT)}{TYS(LT)}$	$\frac{BVS(L)}{TYS(L)}$	$\frac{BVS(LT)}{TYS(LT)}$	$\frac{BVS(L)}{TYS(L)}$	$\frac{BVS(LT)}{TYS(LT)}$	$\frac{BVS(L)}{TYS(L)}$	$\frac{BVS(LT)}{TYS(LT)}$			
0.500	421378	1.031	1.031	---	0.585	0.590	---	$\frac{BVS(L)}{TYS(L)}$ e/D=1.5	$\frac{BVS(LT)}{TYS(LT)}$ e/D=2.0	$\frac{BVS(L)}{TYS(L)}$ e/D=1.5	$\frac{BVS(LT)}{TYS(LT)}$ e/D=2.0	$\frac{BVS(L)}{TYS(L)}$ e/D=1.5	$\frac{BVS(LT)}{TYS(LT)}$ e/D=2.0	
0.500	421379	1.024	1.035	---	0.585	0.586	---	1.513	1.424	1.639	1.543	2.005	1.501	1.649
1.000	421108	1.017	1.017	---	0.577	0.565	---	1.541	1.470	1.693	1.512	1.975	1.432	1.625
1.000	421380	0.989	1.003	---	0.584	0.578	---	1.438	1.370	1.554	1.451	1.906	1.384	1.578
2.000	421381	0.995	1.011	1.029	0.566	0.584	---	1.475	1.399	1.633	1.492	1.917	1.429	1.651
2.000	421382	0.977	0.997	0.994	0.585	0.582	---	1.486	1.396	1.604	1.499	1.954	1.449	1.617
3.000	421083	0.968	1.002	1.000	0.568	0.568	0.487	1.509	1.418	1.606	1.494	1.937	1.408	1.601
3.000	421084	0.984	0.995	0.975	0.573	0.571	0.518	1.487	1.394	1.653	1.422	1.925	1.385	1.623
4.000	421383	0.976	0.988	1.038	0.537	0.587	0.537	1.398	1.870	1.635	1.435	1.883	1.410	1.679
4.000	421384	0.984	1.008	1.019	0.588	0.592	0.538	1.492	1.929	1.656	1.516	1.969	1.442	1.689
								1.437	1.917	1.674	1.516	1.947	1.477	1.668

TABLE 11
 RATIOS AMONG THE TENSILE, COMPRESSIVE, SHEAR AND BEARING PROPERTIES OF 7050-T7351 PLATE
 (F33615-74-C-5089)

Sample Thickness, In.	Compressive						Shear			Bearing (Flatwise)						
	TYS(L)		TYS(LT)		TYS(ST)		TYS(L)		TYS(LT)		TYS(L)		TYS(LT)		TYS(LT)	
	e/D=2.0	e/D=2.0	e/D=2.0	e/D=2.0	e/D=2.0	e/D=2.0	e/D=2.0	e/D=2.0	e/D=2.0	e/D=2.0	e/D=2.0	e/D=2.0	e/D=2.0	e/D=2.0	e/D=2.0	e/D=2.0
2.000	0.975	1.039	1.033	0.605	0.501	---	1.558	1.963	1.502	1.773	1.544	1.960	1.530	1.790	1.530	1.790
2.000	0.977	1.036	1.033	0.609	0.603	---	1.542	1.994	1.492	1.781	1.535	1.990	1.495	1.805	1.495	1.805
3.000	0.964	1.039	1.020	0.611	0.509	0.575	1.523	1.972	1.441	1.684	1.532	1.989	1.491	1.802	1.491	1.802
3.000	0.961	1.037	1.022	0.610	0.504	0.578	1.531	1.976	1.463	1.734	1.510	1.961	1.447	1.745	1.447	1.745
4.000	0.956	1.041	1.024	0.613	0.608	0.563	1.481	1.911	1.459	1.696	1.512	1.972	1.472	1.741	1.472	1.741
4.000	0.954	1.036	1.041	0.613	0.611	0.562	1.531	1.966	1.492	1.756	1.561	1.966	1.543	1.754	1.543	1.754
5.000	0.932	1.022	0.995	0.606	0.602	0.559	1.514	1.920	1.436	1.786	1.487	1.946	1.419	1.727	1.419	1.727
5.118	0.974	1.057	1.024	0.616	0.615	0.583	1.514	1.959	1.487	1.746	1.539	1.971	1.489	1.775	1.489	1.775
6.000	0.953	1.044	1.022	0.613	0.610	0.582	1.541	1.975	1.506	1.819	1.552	1.980	1.535	1.875	1.535	1.875
6.000	0.947	1.048	1.030	0.616	0.613	0.568	1.553	1.964	1.494	1.810	1.528	1.96	1.527	1.750	1.527	1.750

NOTE: See Table 6 for basis of ratio determinations.

TABLE 12
 PATIOS AMONG THE TENSILE, COMPRESSIVE, SHEAR AND BEARING PROPERTIES OF 7475-T7351 PLATE
 (F33615-74-C-5089)

Sample Thickness, in.	Number	Compressive				Shear				Bearing (Flatwise)							
		TYS(LT)		TYS(UT)		TUS(LT)		TUS(UT)		TYS(LT)		TYS(UT)		TUS(LT)		TUS(UT)	
		e/d=1.5	e/d=2.0	e/d=1.5	e/d=2.0	e/d=1.5	e/d=2.0	e/d=1.5	e/d=2.0	e/d=1.5	e/d=2.0	e/d=1.5	e/d=2.0	e/d=1.5	e/d=2.0	e/d=1.5	e/d=2.0
0.500	429422	0.989	1.072	---	---	0.605	0.590	---	---	1.442	1.881	1.370	1.670	1.444	1.895	1.364	1.667
0.500	429423	0.992	1.014	---	---	0.609	0.600	---	---	1.462	1.906	1.428	1.672	1.472	1.915	1.425	1.661
1.000	429387	1.077	1.024	---	---	0.598	0.591	---	---	1.443	1.869	1.366	.657	1.451	1.867	1.369	1.644
1.000	429388	0.981	1.029	---	---	0.501	0.594	---	---	1.457	1.863	1.379	1.653	1.463	1.897	1.391	1.672
2.000	429389	0.971	1.045	1.036	---	0.613	0.619	---	---	1.535	1.989	1.476	1.730	1.555	2.017	1.522	1.828
2.000	429390	0.979	1.031	1.041	---	0.621	0.610	---	---	1.538	1.995	1.500	1.759	1.546	1.986	1.505	1.713
3.000	429391	0.975	1.057	1.047	---	0.637	0.634	0.597	---	1.547	2.012	1.504	1.772	1.555	2.113	1.530	1.780
3.000	429392	0.957	1.043	1.034	---	0.633	0.633	0.587	---	1.532	1.984	1.495	1.750	1.544	1.958	1.511	1.743
4.000	429393	0.945	1.033	1.039	---	0.635	0.627	0.592	---	1.520	1.991	1.485	1.718	1.517	1.968	1.502	1.738
4.000	429394	0.959	1.041	1.051	---	0.637	0.632	0.591	---	1.533	1.964	1.516	1.770	1.518	1.967	1.516	1.746

NOTE: See Table 7 for basis of ratio determinations.

TABLE 13

LOS AMONG TENSILE, COMPRESSIVE, SHEAR AND HEARING PROPERTIES OF 7475-T7351 PLATE (CURRENT PRACTICE)

Sample Thickness, Number	Compressive			hear			hearing (Flatwise)							
	$\frac{TS(0)}{TS(L)}$	$\frac{CS(0)}{CS(L)}$	$\frac{CS(C)}{CS(L)}$	$\frac{TS(L)}{TS(H)}$	$\frac{TS(0)}{TS(H)}$	$\frac{TS(C)}{TS(H)}$	$\frac{TS(0)}{TS(L)}$	$\frac{TS(L)}{TS(H)}$	$\frac{TS(C)}{TS(H)}$	$\frac{TS(0)}{TS(L)}$	$\frac{TS(L)}{TS(H)}$	$\frac{TS(C)}{TS(H)}$	$\frac{TS(0)}{TS(L)}$	$\frac{TS(L)}{TS(H)}$
0.500	0.976	1.044	---	0.598	0.594	---	1.524	1.985	1.428	1.799	1.556	1.958	1.492	1.762
0.750	0.995	1.046	---	0.582	0.575	---	1.473	1.917	1.389	1.700	1.478	1.889	1.407	1.636
3.500	0.968	1.049	1.058	0.625	0.615	0.551	1.557	2.053	1.516	1.806	1.606	2.010	1.633	1.926

TABLE 14
 RATIOS AMONG THE TENSILE, COMPRESSIVE, SHEAR, AND BEARING PROPERTIES OF 2219-T852 HAND FORGINGS
 (F33615-74-C-5089)

Sample Dimensions, in.	Sample Number	Compressive		Shear		Bearing (Reverse)									
		$\frac{CYS(L)}{TYS(L)}$	$\frac{CYS(S)}{TYS(S)}$	$\frac{SUS(L)}{TUS(L)}$	$\frac{SUS(S)}{TUS(S)}$	$\frac{BYS(L)}{TYS(L)}$	$\frac{BYS(S)}{TYS(S)}$	$\frac{BYS(L)}{TYS(L)}$	$\frac{BYS(S)}{TYS(S)}$	$\frac{BYS(L)}{TYS(L)}$	$\frac{BYS(S)}{TYS(S)}$				
1.0x8	429C46	1.038	1.053	1.059	0.623	0.626	--	1.244	1.747	1.611	1.913	1.386	1.614	1.678	1.917
2.5x20	478817	1.012	1.052	1.056	0.607	0.600	0.556	1.240	1.712	1.527	1.680	1.294	1.799	1.571	1.936
3.5x14	429512	0.960	0.966	0.966	0.651	0.604	0.585	1.432	1.930	1.572	1.809	1.391	1.831	1.540	1.785
3.5x22	429513	0.946	0.958	0.948	0.637	0.613	0.551	1.271	1.770	1.536	1.785	1.239	1.711	1.536	1.771
4.5x20	429249	0.926	0.980	0.998	0.676	0.659	0.624	1.405	1.822	1.582	1.871	1.441	1.959	1.595	2.055
4.5x22	429514	0.925	0.931	0.950	0.648	0.626	0.585	1.318	1.843	1.563	1.802	1.348	1.805	1.581	1.840
5.5x22	429247	1.009	1.050	1.017	0.649	0.642	0.606	1.432	1.890	1.636	1.961	1.464	1.909	1.685	1.983
5.5x22	429C48	1.064	1.088	1.021	0.687	0.678	0.632	1.448	1.903	1.756	2.002	1.500	1.940	1.759	2.021
7.5x22	429244	0.945	0.927	0.963	0.652	0.659	0.649	1.453	1.918	1.539	1.785	1.464	1.939	1.546	1.822
7.5x22	429245	0.991	0.952	0.986	0.672	0.672	0.660	1.502	2.005	1.627	1.891	1.505	1.959	1.674	1.952

TABLE 15
 2019-1850, 7050-17351 AND COMPRESSION ELASTICITY TESTS OF
 2019-1850, 7050-17351 AND 7475-17351 PLATE AND 19-1850 HAND FORGING
 (F33615-74-C-5089)

Alloy Temp	Stress ksi	Strain %	Sample Number	Longitudinal		Long-Transverse		Short-Transverse		Nominal Stress, ksi	Nominal Strain, %
				Tensile, ksi	Compressive, ksi	Tensile, ksi	Compressive, ksi	Tensile, ksi	Compressive, ksi		
2019-1850	Plate	1.5	421378	10.36	10.83	10.53	10.88	---	---	10.4	10.7
		2.0	421381	10.33	10.68	10.41	10.71	10.22	10.70		
		3.0	421083	10.36	10.76	10.44	10.91	10.22	10.65		
		4.0	421384	10.44	10.75	10.45	10.80	10.37	10.70		
7050-17351	Average		10.37	10.76	10.46	10.82	10.27	10.68	10.27	10.4	10.7
		2.0	421074	10.27	10.52	10.37	10.74	10.15	10.59	10.15	10.71
		3.0	421076	10.25	10.61	10.41	10.70	10.16	10.71	10.21	10.73
		4.0	421077	10.25	10.56	10.30	10.80	10.21	10.50	10.50	10.57
7475-17351	Average		10.24	10.54	10.34	10.70	10.19	10.62	10.19	10.3	10.6
		0.5	429402	10.40	10.75	10.52	10.94	---	---	---	---
		2.0	429389	10.23	10.77	10.35	10.72	10.21	10.70	10.22	10.62
		3.0	429391	10.19	10.48	10.27	10.70	10.22	10.62	10.22	10.62
2019-1850 and Forging	Average		10.27	10.60	10.36	10.74	10.22	10.64	10.22	10.3	10.6
		3.0	429246	10.42	10.58	10.45	10.65	10.05	10.41	10.05	10.41
		4.5	429247	10.31	10.44	10.14	10.30	10.06	10.08	10.06	10.08
		5.5	429248	10.29	10.66	10.40	10.67	10.37	10.50	10.37	10.50
Average		10.13	10.20	10.21	10.52	10.04	10.20	9.98	10.10	10.2	10.4
		10.31	10.46	10.31	10.49	10.10	10.26	10.10	10.26	10.2	10.4

TABLE 16
TYPICAL STRESS-STRAIN DATA FOR 2048-T851 PLATE
(F33615-74-C-5089)

Strain Departure u in./in.	Tenslon (Modulus: 10.4 x 10 ³ ksi)				Compression (Modulus: 10.7 x 10 ³ ksi)			
	Longitudinal (a)		Short-Transverse (b)		Longitudinal (a)		Short-Transverse (b)	
	Stress, ksi (% TYS)	Strain, u in./in.	Stress, ksi (% TYS)	Strain, u in./in.	Stress, ksi (% CYS)	Strain, u in./in.	Stress, ksi (% CYS)	Strain, u in./in.
0	25.1 (40.5)	2414	23.3 (40.9)	2245	44.4 (72.8)	4150	43.4 (70.0)	4076
20	34.0 (54.8)	3286	31.7 (55.6)	3069	47.7 (78.2)	4481	48.0 (77.4)	4503
40	40.0 (64.5)	3890	37.1 (65.1)	3612	49.2 (80.7)	4638	49.6 (80.0)	4650
60	44.1 (71.0)	4300	39.6 (69.8)	3871	50.1 (82.2)	4745	50.8 (82.0)	4811
80	46.9 (75.6)	4586	41.4 (72.6)	4056	50.9 (83.5)	4838	51.7 (83.4)	4915
100	49.1 (79.2)	4816	46.3 (75.9)	4554	51.6 (84.6)	4919	52.4 (84.5)	5001
150	52.4 (84.5)	5187	49.0 (80.3)	4860	52.8 (86.5)	5080	53.8 (86.8)	5181
200	54.4 (87.7)	5430	45.0 (78.9)	4474	53.7 (88.0)	5219	54.8 (88.4)	5320
250	55.7 (89.9)	5609	47.6 (81.4)	4664	54.4 (89.2)	5336	55.6 (89.7)	5449
300	56.7 (91.5)	5755	48.5 (85.1)	4968	55.0 (90.2)	5442	56.3 (90.8)	5564
350	57.4 (92.6)	5874	49.3 (86.5)	5092	55.6 (91.1)	5543	56.8 (91.6)	5662
400	58.1 (93.1)	5983	50.0 (87.7)	5204	56.0 (91.8)	5634	57.3 (92.4)	5755
500	59.0 (95.1)	6170	51.0 (89.5)	5488	56.7 (93.0)	5803	58.1 (93.7)	5928
600	59.6 (96.2)	6334	51.9 (91.1)	5592	57.4 (94.1)	5961	58.7 (94.7)	6088
800	60.5 (97.6)	6616	53.3 (93.5)	5724	58.3 (95.6)	6249	59.6 (96.1)	6373
1000	61.0 (98.4)	6867	54.3 (95.2)	6219	59.0 (96.7)	6514	60.3 (97.3)	6632
1500	61.7 (99.5)	7432	56.0 (98.2)	6880	60.2 (98.7)	7124	61.3 (98.9)	7230
2000	62.0 (100.0)	7962	57.0 (100.0)	7481	61.0 (100.0)	7701	62.0 (100.0)	7794
2200	62.1 (100.2)	8171	57.3 (100.6)	7715	61.2 (100.4)	7922	62.2 (100.3)	8013
2300	---	---	57.5 (100.9)	7830	61.4 (100.6)	8034	62.3 (100.5)	8123
2400	---	---	57.6 (101.1)	7943	61.5 (100.8)	8146	62.4 (100.6)	8231
2500	---	---	57.8 (101.4)	8056	---	---	62.5 (100.8)	8340

(a) Data based on tests of four samples, 0.5, 2, 3.0 and 4.0-in. thick.
(b) Data based on tests of three samples, 2.0, 3.0 and 4.0-in. thick.

TABLE 17
TYPICAL STRESS-STRAIN DATA FOR 7050-T7351 PLATE

(T-33615-74-C-5089)

Strain temperature μ in./in.	Tension (Modulus: 10.3 x 10 ³ ksi)		Short-Transverse (a)		Longitudinal (a)		Compression (Modulus: 10.6 x 10 ³ ksi)	
	Longitudinal stress, ksi (% CY)	Strain, μ in./in.	Longitudinal stress, ksi (% CY)	Strain, μ in./in.	Longitudinal stress, ksi (% CY)	Strain, μ in./in.	Longitudinal stress, ksi (% CY)	Strain, μ in./in.
0	24.0 (36.7)	2327	22.3 (36.5)	2167	39.0 (65.0)	3682	43.8 (68.5)	4135
20	31.8 (51.3)	3108	24.8 (51.3)	2911	43.5 (72.4)	4120	47.8 (74.6)	4525
40	37.5 (60.0)	3650	34.3 (59.1)	3369	45.5 (75.8)	4332	49.7 (77.6)	4727
60	40.8 (65.8)	4000	37.3 (64.3)	3678	46.0 (78.2)	4488	51.0 (79.6)	4868
80	43.4 (70.0)	4299	39.5 (68.2)	3718	47.8 (79.7)	4593	51.9 (81.1)	4980
100	45.7 (73.7)	4535	41.1 (70.9)	4093	48.8 (81.3)	4790	52.7 (82.3)	5069
150	49.5 (79.8)	4958	44.0 (75.8)	4400	50.2 (83.7)	4890	54.3 (84.8)	5272
200	51.9 (83.7)	5241	45.8 (79.0)	4651	51.3 (81.5)	5043	55.4 (86.6)	5430
250	53.7 (86.6)	5453	47.3 (81.5)	4841	52.2 (87.0)	5177	56.3 (88.0)	5565
300	55.0 (88.7)	5639	48.4 (83.5)	4999	52.9 (88.2)	5244	57.1 (89.2)	5686
350	56.0 (90.3)	5790	49.3 (85.0)	5135	53.5 (89.2)	5399	57.7 (90.2)	5796
400	56.8 (91.6)	5917	50.1 (86.3)	5301	54.1 (90.1)	5499	58.3 (91.1)	5898
500	58.0 (93.6)	6134	51.3 (88.4)	5474	54.9 (91.5)	5679	59.2 (92.5)	6082
600	58.9 (95.0)	6315	52.2 (90.1)	5672	55.6 (92.7)	5845	59.9 (93.6)	6251
800	60.0 (96.8)	6625	53.7 (92.6)	6016	56.7 (94.5)	6147	61.0 (95.3)	6554
1000	60.7 (97.9)	6891	54.8 (94.5)	6323	57.5 (95.8)	6402	61.8 (96.6)	6823
1500	61.5 (99.3)	7477	56.7 (97.3)	7007	59.0 (98.3)	7063	63.1 (98.7)	7457
2000(Y)	62.0 (100.0)	8019	58.0 (100.0)	7631	60.0 (100.0)	7660	64.0 (100.0)	8038
2400	62.1 (100.2)	8231	58.4 (100.7)	7872	60.4 (100.6)	7894	64.3 (100.4)	8264
2300	62.2 (100.3)	8337	58.6 (101.0)	7990	60.5 (100.8)	8008	64.4 (100.6)	8376
2400	62.2 (100.3)	8441	58.8 (101.4)	8108	---	---	---	---
2500	62.3 (100.4)	8546	59.0 (101.7)	8226	---	---	---	---

(1) Data based on tests of five samples, 2.0, 3.0, 4.0, 5.0 and 6.0-in. thick.

TABLE 19
 DATA FOR ESTABLISHING TYPICAL STRESS-STRAIN CURVES FOR 2219-T852 HAND FORGINGS
 (F33615-74-C-5089)

Strain Departure u in./in.	Percentage of Yield Stress (a)					
	Tension (Modulus 10.2 x 10 ³ ksi)		Compression (Modulus 10.4 x 10 ³ ksi)		Short-Transverse	
	Longitudinal	Short-Transverse	Longitudinal	Short-Transverse	Longitudinal	Short-Transverse
0	47.8	51.2	44.3	65.2	63.7	57.9
20	61.3	63.5	56.0	74.1	75.9	67.1
40	68.3	70.4	52.9	77.8	79.4	72.9
60	73.3	74.5	67.1	80.4	82.0	75.9
80	76.9	77.4	70.2	82.2	83.6	78.2
100	79.6	79.7	73.2	83.7	84.8	80.1
150	84.1	83.4	78.0	86.3	87.2	83.4
200	86.9	85.9	81.4	88.0	88.8	85.8
250	88.9	87.7	84.0	89.3	90.0	87.5
300	90.4	89.1	86.0	90.5	91.0	88.9
350	91.5	90.3	87.5	91.3	91.8	90.0
400	92.4	91.2	88.8	92.1	92.5	91.0
500	93.8	92.7	90.8	93.3	93.6	92.5
600	94.9	93.8	92.4	94.3	94.5	93.7
800	96.3	95.5	94.6	95.7	95.9	95.4
1000	97.3	96.7	96.1	96.7	96.9	96.6
1250	98.2	97.8	97.5	97.8	97.9	97.8
1500	98.9	98.7	98.5	98.6	98.7	98.6
1750	99.5	99.4	99.3	99.4	99.4	99.4
2000 (Ys)	100.0	100.0	100.0	100.0	100.0	100.0
2100	100.2	100.2	100.2	100.3	100.2	100.2
2200	100.4	100.4	100.5	100.5	100.5	100.4
2300	100.5	---	100.7	100.7	100.7	100.7
2400	100.7	---	100.9	100.9	100.9	---
2500	100.7	---	101.1	101.2	100.9	---

(a) Data based on tests of four samples, 2.0, 3.5, 4.5 and 5.5-in. thick.

TABLE 20
 DATA FOR TYPICAL COMPRESSIVE TANGENT-MODULUS CURVES FOR
 2048-T851, 7050-T7351 AND 7475-T7351 PLATE
 (F33615-74-C-5089)

Modulus,	2048-T851			7050-T7351			7475-T7351		
	Longitudinal	Long-Transverse	Short-Transverse	Longitudinal	Long-Transverse	Short-Transverse	Longitudinal	Long-Transverse	Short-Transverse
10.7	44.4	43.4	42.9	---	---	---	---	---	---
10.6	---	---	---	39.0	43.8	43.4	42.0	43.7	44.0
10.5	45.3	44.4	43.7	39.8	44.1	44.2	42.4	44.3	44.3
10.2	46.0	45.5	44.9	41.7	45.6	45.8	43.9	46.0	45.3
10.0	46.8	46.8	45.7	42.8	46.6	46.7	44.8	47.1	46.1
9.7	47.7	48.0	46.8	44.2	48.0	48.0	46.1	48.3	47.2
9.3	48.7	49.5	48.3	45.8	49.6	49.4	47.6	49.8	48.4
9.0	49.3	50.4	49.3	46.8	50.5	50.3	48.5	50.6	49.2
8.5	50.4	51.7	50.7	49.3	52.0	51.7	49.6	51.8	50.5
8.0	51.3	52.7	51.7	49.4	53.3	52.8	50.5	52.8	51.6
7.0	52.9	54.5	53.5	51.1	55.4	54.6	51.7	54.5	53.2
6.0	54.2	55.8	55.0	52.6	57.1	56.2	52.9	55.8	54.4
5.0	55.6	57.1	56.2	54.1	58.6	57.5	53.9	57.0	55.5
4.0	56.9	58.2	57.3	55.5	59.9	58.8	55.0	58.2	56.5
3.0	58.0	59.2	58.5	57.0	61.2	60.1	56.0	59.2	57.9
2.5	58.7	59.9	59.0	57.9	61.9	60.8	56.5	59.9	58.7
2.0	59.5	60.4	59.6	58.8	62.6	61.6	57.2	60.4	59.5
1.5	60.4	61.1	60.1	60.1	63.5	62.5	58.1	61.0	60.7
1.3	60.8	61.4	60.3	60.6	63.9	62.8	58.7	61.4	61.1
1.1	61.4	61.7	60.7	---	64.4	63.2	59.4	61.9	61.6
0.7	---	62.5	---	---	---	---	---	62.6	---

TABLE 21
RESULTS OF FRACTURE TOUGHNESS TESTS OF 2048-T051 PLATE
(P33615-74-C-5089)

Crack Thickness, in.	Specimen Number	T-T Orientation			T-L Orientation			3-L Orientation			
		Yield Strength, ksi	Specimen Number	Crack Length, in.	K_{Ic} , ksi√in.	Valid	Yield Strength, ksi	Specimen Number	Crack Length, in.	K_{Ic} , ksi√in.	Valid
0.500	421378	62.2	T1	1.03	34.8	No (b,c)	61.5	T1	1.02	34.8	No (b,c)
			T2	1.03	32.2	No (b,c)		T2	1.02	32.2	No (b,c)
			T3	1.02	32.0	No (b,c)		T3	1.03	32.0	No (b,c)
0.500	421379	63.8	T1	1.00	35.1	No (b,c)	61.2	T1	1.02	32.9	No (b,c)
			T2	1.05	37.4	No (b,c)		T2	1.04	37.4	No (b,c)
			T3	1.02	32.2	No (b,c)		T3	1.03	32.2	No (b,c)
1.000	421108	67.5	T1	1.04	35.7	Yes	65.4	T1	1.02	30.7	Yes
			T2	1.00	35.2	Yes		T2	1.00	30.0	Yes
			T3	1.02	35.5	Yes		T3	1.05	30.9	Yes
1.000	421389	62.1	T1	1.00	38.2	No (d)	61.1	T1	1.00	31.8	Yes
			T2	1.03	36.7	No (d)		T2	1.03	31.7	Yes
			T3	1.03	37.3	No (d)		T3	1.03	31.7	Yes
2.000	421381	65.9	T1	2.07	39.6	Yes	61.6	T1	2.05	30.9	Yes
			T2	2.06	42.4	Yes		T2	2.06	29.5	Yes
			T3	2.05	41.0	Yes		T3	2.09	29.7	Yes
2.000	421382	63.4	T1	1.98	39.9	Yes	62.4	T1	1.98	28.5	Yes
			T2	1.98	39.4	Yes		T2	1.98	29.2	Yes
			T3	1.98	38.2	Yes		T3	1.98	29.9	Yes
3.000	421083	60.4	T1	3.00	37.6	Yes	60.4	T1	3.00	33.6	Yes
			T2	3.12	36.7	Yes		T2	3.04	33.6	Yes
			T3	3.00	36.9	Yes		T3	3.10	33.6	Yes
3.000	421084	60.1	T1	3.06	38.5	Yes	60.5	T1	3.00	34.5	Yes
			T2	3.07	38.8	Yes		T2	3.24	34.5	Yes
			T3	3.08	37.3	Yes		T3	3.28	34.3	Yes
4.000	421383	59.1	T1	2.00	38.2	Yes	57.3	T1	2.00	28.2	Yes
			T2	2.00	38.4	Yes		T2	2.00	28.4	Yes
			T3	2.02	38.1	Yes		T3	2.03	28.2	Yes
4.000	421384	61.2	T1	2.00	37.2	Yes	61.9	T1	2.00	28.2	Yes
			T2	2.00	37.6	Yes		T2	2.00	28.0	Yes
			T3	2.02	37.9	Yes		T3	2.02	28.0	Yes

(a) Valid value only.
 (b) Insufficient specimen thickness, $B \geq 2.5 \left(\frac{K_{Ic}}{\sigma_{YS}} \right)^2$.
 (c) $P_{max} > 1.1$, where P_Q and P_{max} are 5 per cent secant load and peak load, respectively.
 (d) Same as (c). However, P_{max}/P_Q is in meaningful range of 1.05 to 1.200.

TABLE 22
RESULTS OF FRACTURE TOUGHNESS TESTS OF 7050-T7351 PLATE
(F33615-74-C-5089)

Sample Number	T-T Orientation				S-L Orientation				K _{IC} (ksi√in.)				
	Valid Strength, ksi	Specimen Number	Crack Length, in.	Crack Width, in.	Valid Strength, ksi	Specimen Number	Crack Length, in.	Crack Width, in.					
2 020	61.0	L1	2.01	1.04	32.3	T1	2.00	2.07	0.73	32.6	Yes	27.7	Yes
		L2	2.01	1.04	34.3	T2	2.00	2.05	0.71	32.2	Yes	27.5	Yes
		L3	2.02	1.05	39.4	T3	2.00	2.07	0.71	32.4	Yes	26.0	Yes
3 020	60.5	L1	2.01	1.26	43.0	T1	2.00	2.07	0.83	34.6	Yes	29.9	Yes
		L2	2.01	1.18	41.5	T2	2.00	2.06	0.83	34.5	Yes	28.8	Yes
		L3	2.02	1.28	43.1	T3	2.00	2.06	0.88	34.9	Yes	29.2	Yes
3 020	63.7	L1	1.56	0.72	34.1	T1	1.50	1.58	0.55	30.0	Yes	27.8	Yes
		L2	1.56	0.76	35.0	T2	1.50	1.56	0.57	30.3	Yes	27.0	Yes
		L3	1.56	0.75	34.7	T3	1.50	1.56	0.55	30.2	Yes	27.3	Yes
3 020	63.9	L1	1.57	0.73	34.5	T1	1.50	1.59	0.55	30.1	Yes	27.0	Yes
		L2	1.57	0.75	35.1	T2	1.50	1.59	0.57	30.4	Yes	28.7	Yes
		L3	1.57	0.79	35.2	T3	1.50	1.59	0.56	30.2	Yes	27.9	Yes
4 020	63.7	L1	2.06	0.82	36.5	T1	2.00	2.10	0.58	30.8	Yes	29.2	Yes
		L2	2.09	0.82	35.1	T2	2.00	2.10	0.58	30.6	Yes	28.9	Yes
		L3	2.09	0.82	36.1	T3	2.00	2.10	0.58	30.6	Yes	29.0	Yes
4 020	63.7	L1	2.06	0.72	34.6	T1	2.00	2.04	0.54	29.4	Yes	27.7	Yes
		L2	2.08	0.72	34.3	T2	2.00	2.08	0.51	29.4	Yes	26.5	Yes
		L3	2.08	0.72	34.1	T3	2.00	2.09	0.51	29.1	Yes	28.5	Yes
5 000	63.7	L1	2.06	0.73	34.3	T1	2.00	2.11	0.53	29.4	Yes	27.9	Yes
		L2	2.05	0.68	33.3	T2	2.00	2.12	0.53	29.4	Yes	28.2	Yes
		L3	2.05	0.68	33.7	T3	2.00	2.12	0.53	29.5	Yes	28.3	Yes
6 118	63.2	L1	2.00	0.54	29.3	T1	2.00	2.06	0.41	24.9	No(b)	26.2	Yes
		L2	2.00	0.55	29.1	T2	2.00	2.02	0.41	24.9	Yes	25.5	Yes
		L3	2.00	0.55	29.4	T3	2.00	2.05	0.41	25.0	Yes	26.0	Yes
7 020	60.4	L1	2.06	0.77	33.6	T1	2.00	2.09	0.66	30.3	Yes	28.9	Yes
		L2	2.04	0.77	33.5	T2	2.00	2.07	0.63	29.8	Yes	28.7	Yes
		L3	2.05	0.77	33.8	T3	2.00	2.08	0.63	29.9	Yes	28.2	Yes
8 020	62.2	L1	2.01	0.55	29.1	T1	2.00	2.05	0.48	26.7	Yes	26.3	Yes
		L2	2.04	0.54	28.9	T2	2.00	2.08	0.48	26.3	Yes	26.1	Yes
		L3	2.02	0.53	28.9	T3	2.00	2.08	0.48	26.5	Yes	26.5	Yes

(a) Average of valid K_{IC} values.

(b) K_{IC} greater than 0.6 K_{IC} for the last step of fatigue cracking. However, K_{IC}/K_{IC} is in meaningful range of 0.60 to 0.700.

TABLE 23
RESULTS OF FRACTURE TESTS OF 7475-T7351 PLATE
(F33615-74-C-5089)

Diameter, in.	Specimen ID	L-T Orientation				T-L Orientation				45-Degree Orientation								
		Yield strength, ksi	Specimen Number	Crack Length, in.	$2.5 \sqrt{a_0}^2$	Yield strength, ksi	Specimen Number	Crack Length, in.	$2.5 \sqrt{a_0}^2$	Yield strength, ksi	Specimen Number	Crack Length, in.	$2.5 \sqrt{a_0}^2$	Yield strength, ksi	Specimen Number	Crack Length, in.	$2.5 \sqrt{a_0}^2$	
2.50	42942V	63.4	L1	0.50	0.74	63.2	T1	0.50	0.70	---	---	---	---	---	---	---	---	
		---	L2	0.50	0.51	---	T2	0.50	0.71	---	---	---	---	---	---	---	---	---
		---	L3	0.50	0.49	---	T3	0.50	0.69	---	---	---	---	---	---	---	---	---
2.50	42943V	63.3	L1	0.49	0.96	63.9	T1	0.49	0.66	---	---	---	---	---	---	---	---	
		---	L2	0.49	0.52	---	T2	0.49	0.67	---	---	---	---	---	---	---	---	---
		---	L3	0.49	0.87	---	T3	0.49	0.64	---	---	---	---	---	---	---	---	---
1.00	42927V	61.6	L1	1.00	1.13	61.6	T1	1.00	0.84	---	---	---	---	---	---	---	---	
		---	L2	1.00	1.03	---	T2	1.00	0.78	---	---	---	---	---	---	---	---	---
		---	L3	1.00	1.11	---	T3	1.00	0.81	---	---	---	---	---	---	---	---	---
1.00	42930V	59.4	L1	1.00	1.31	59.4	T1	1.00	0.88	---	---	---	---	---	---	---	---	
		---	L2	1.00	1.27	---	T2	1.00	0.90	---	---	---	---	---	---	---	---	---
		---	L3	1.00	1.25	---	T3	1.00	0.90	---	---	---	---	---	---	---	---	---
2.00	42937V	57.7	L1	1.97	1.37	57.7	T1	1.97	0.82	---	---	---	---	---	---	---	---	
		---	L2	1.97	1.37	---	T2	1.97	0.79	---	---	---	---	---	---	---	---	---
		---	L3	1.97	1.22	---	T3	1.97	0.80	---	---	---	---	---	---	---	---	---
2.00	42939V	58.3	L1	1.97	1.43	58.3	T1	1.97	0.75	---	---	---	---	---	---	---	---	
		---	L2	1.97	1.51	---	T2	1.97	0.77	---	---	---	---	---	---	---	---	---
		---	L3	1.97	1.22	---	T3	1.97	0.79	---	---	---	---	---	---	---	---	---
3.00	42932V	55.7	L1	2.86	1.81	55.7	T1	2.00	0.80	---	---	---	---	---	---	---	---	
		---	L2	2.86	1.80	---	T2	2.00	0.80	---	---	---	---	---	---	---	---	---
		---	L3	2.86	1.89	---	T3	1.99	0.86	---	---	---	---	---	---	---	---	---
3.00	42933V	56.4	L1	2.82	1.83	56.4	T1	1.99	0.82	---	---	---	---	---	---	---	---	
		---	L2	2.86	1.80	---	T2	2.00	0.82	---	---	---	---	---	---	---	---	---
		---	L3	2.82	1.96	---	T3	2.00	0.77	---	---	---	---	---	---	---	---	---
4.00	42933V	54.2	L1	3.00	1.96	54.2	T1	1.99	0.89	---	---	---	---	---	---	---	---	
		---	L2	2.97	1.87	---	T2	1.98	0.96	---	---	---	---	---	---	---	---	---
		---	L3	3.00	1.88	---	T3	1.99	0.96	---	---	---	---	---	---	---	---	---
4.00	42934V	53.1	L1	3.00	1.72	53.1	T1	1.99	0.95	---	---	---	---	---	---	---	---	
		---	L2	2.97	1.76	---	T2	1.98	0.96	---	---	---	---	---	---	---	---	---
		---	L3	2.97	1.76	---	T3	1.98	0.96	---	---	---	---	---	---	---	---	---

a) Insufficient specimen thickness, $B \geq 2.5 \sqrt{a_0}$

b) Fatigue crack is too short, $2.5 \sqrt{a_0} > a$ (area & length)

c) $\frac{P_{max}}{P_0} > 1.1$ where P_0 and P_{max} are 5 percent secant load and peak load, respectively.

TABLE 24
RESULTS OF FRACTURE TOUGHNESS TESTS OF 7475-T7351 PLATE (CURRENT PRACTICE)
(M.T. NO. 110176-4)

Sample Thickness, number in.	I-I Orientation				T-I Orientation				T-I Orientation				
	Tensile Yield Strength, ksi	Specimen Number	Crack Length, in.	$2.5 \left(\frac{K_{Ic}}{\sigma_y} \right)^2$ ksi/in.	Tensile Strength, ksi	Specimen Number	Crack Length, in.	$2.5 \left(\frac{K_{Ic}}{\sigma_y} \right)^2$ ksi/in.	Tensile Yield Strength, ksi	Specimen Number	Crack Length, in.	$2.5 \left(\frac{K_{Ic}}{\sigma_y} \right)^2$ ksi/in.	Valid
0.500	479717	11	0.49	2.99	2.39	71	0.49	1.99	1.11	42.0	0.75	1.11	No (a,c)
		12	0.49	2.99	2.44	72	0.49	2.00	1.11	42.6	0.75	1.11	No (a,c)
0.750	478718	11	0.76	3.03	2.20	71	0.76	2.01	1.15	43.3	0.75	1.15	No (a,c)
		12	0.76	3.09	2.05	72	0.76	2.01	1.19	44.1	0.75	1.19	No (a,c)
1.750	478824	11	1.74	3.00	1.89	71	1.75	3.07	1.02	58.4	0.75	1.04	No (a,b)
		12	1.74	3.00	1.72	72	1.75	3.07	1.05	58.4	0.75	1.04	No (a,b)
Average													
1.750	478825	11	1.75	3.03	1.83	71	1.76	3.02	0.99	57.7	0.75	0.85	No (a,b)
		12	1.74	3.01	1.83	72	1.76	3.03	0.98	57.7	0.75	0.86	No (a,b)
Average													
2.250	478826	11	2.26	3.00	1.52	71	2.26	3.06	0.95	58.7	0.75	0.79	No (a,b)
		12	2.26	3.00	1.54	72	2.26	3.08	0.97	58.7	0.75	0.79	No (a,b)
Average													
2.250	478827	11	2.25	3.02	1.72	71	2.25	3.07	0.95	55.7	0.75	0.87	No (a,b)
		12	2.25	3.02	1.69	72	2.25	3.10	0.96	55.7	0.75	0.91	No (a,b)
Average													
2.750	478828	11	2.75	2.99	1.87	71	2.75	3.08	1.05	55.3	1.00	0.99	Yes
		12	2.75	2.99	1.83	72	2.75	3.08	1.05	55.3	1.00	0.99	Yes
Average													
2.750	478829	11	2.74	3.00	1.61	71	2.74	3.14	0.88	54.3	1.00	0.87	Yes
		12	2.73	3.01	1.69	72	2.74	3.08	0.88	54.3	1.00	0.87	Yes
Average													
3.500	478830	11	3.00	3.15	1.82	71	3.00	3.20	1.07	54.4	1.25	0.95	Yes
		12	3.00	3.15	1.87	72	3.00	3.19	1.09	54.4	1.25	0.89	Yes
Average													
3.500	478861	11	3.00	3.10	1.75	71	3.00	3.17	1.04	54.2	1.25	0.85	Yes
		12	3.00	3.12	1.78	72	3.00	3.16	1.00	54.2	1.25	0.88	Yes
Average													

(a) Insufficient specimen thickness, $B < 2.5 \left(K_{Ic} / \sigma_y \right)^2$.
 (b) Insufficient crack length, $A < 2.5 \left(K_{Ic} / \sigma_y \right)^2$.
 (c) $P_{max} / P_0 > 1.1$.
 (d) Values considered meaningless.

TABLE 25
RESULTS OF FRACTURE-TOUGHNESS TESTS OF 2019-T852 HAND FORDINGS
(P33615-74-C-5089)

Specimen ID	Sample Number	[L-T] Orientation			[T-L] Orientation			[S-L] Orientation							
		Tensile Strength, ksi	Crack Length, in.	$2.5(K_{Ic}/\sigma)^2$ ksi ² in.	Tensile Strength, ksi	Crack Length, in.	$2.5(K_{Ic}/\sigma)^2$ ksi ² in.	Tensile Strength, ksi	Crack Length, in.	$2.5(K_{Ic}/\sigma)^2$ ksi ² in.					
2	DPA	429246	L-1	1.50	1.87	1.89	1.50	1.56	0.75	0.80	0.75	28.3	No(b)	Yes	
			L-2	1.50	1.51	1.54	1.50	1.51	0.84	0.75	0.79	0.85	30.1	No(b)	Yes
			L-3	1.50	1.55	1.54	1.50	1.56	0.84	0.75	0.80	0.68	25.6	Yes	Yes
2	5x22	478817	L-1	2.49	2.53	1.47	2.49	2.51	0.66	1.00	0.48	22.6	Yes	Yes	
			L-2	2.50	2.54	1.33	2.50	2.56	0.93	1.00	1.01	0.43	21.2	Yes	Yes
			L-3	2.50	2.45	1.35	2.49	2.57	0.67	1.00	1.01	0.43	21.2	Yes	Yes
3	5x14	429512	L-1	2.50	2.57	1.67	2.50	2.56	0.80	1.00	0.67	25.8	Yes	Yes	
			L-2	2.50	2.56	1.76	2.50	2.58	0.80	1.00	1.00	0.65	25.3	Yes	Yes
			L-3	2.50	2.65	1.97	2.50	2.56	0.83	1.00	1.04	0.64	25.4	Yes	Yes
3	5x22	429513	L-1	2.50	2.60	1.59	2.50	2.50	0.62	1.01	0.54	23.8	Yes	Yes	
			L-2	2.50	2.51	1.69	2.50	2.52	0.67	1.00	1.04	0.62	23.5	Yes	Yes
			L-3	2.50	2.58	1.69	2.50	2.53	0.68	1.00	1.02	0.61	23.2	Yes	Yes
4	5x22	429249	L-1	2.50	2.58	1.60	2.50	2.53	0.74	1.55	0.68	24.4	Yes	Yes	
			L-2	2.50	2.56	1.63	2.50	2.50	0.71	1.50	1.55	0.67	24.3	Yes	Yes
			L-3	2.50	2.56	1.63	2.50	2.50	0.71	1.50	1.51	0.56	22.2	Yes	Yes
4	5x22	429514	L-1	2.50	2.60	1.49	2.50	2.51	0.86	1.53	0.68	26.7	Yes	Yes	
			L-2	2.50	2.56	1.96	2.50	2.51	0.74	1.50	1.57	0.59	23.4	Yes	Yes
			L-3	2.50	2.56	2.16	2.50	2.57	0.83	1.50	1.57	0.63	23.1	Yes	Yes
5	5x22	429247	L-1	2.50	2.63	1.87	2.50	2.52	0.74	2.08	0.62	23.7	No(d)	Yes	
			L-2	2.50	2.64	1.58	2.50	2.64	0.55	2.06	0.62	0.62	19.8	No(d)	Yes
			L-3	2.50	2.65	1.58	2.50	2.64	0.55	2.00	2.07	0.53	21.7	No(d)	Yes
5	5x22	429248	L-1	2.50	2.52	1.91	2.50	2.57	1.10	2.05	0.68	26.6	Yes	Yes	
			L-2	2.50	2.54	1.89	2.50	2.62	1.07	2.04	0.60	24.9	Yes	Yes	
			L-3	2.50	2.55	2.09	2.50	2.58	0.73	2.00	2.04	0.59	23.1	Yes	Yes
7	5x22	429244	L-1	2.50	2.58	1.73	2.50	2.60	0.85	2.03	0.69	22.3	No(d)	Yes	
			L-2	2.50	2.57	1.80	2.50	2.60	0.85	2.00	2.00	0.71	22.6	No(d)	Yes
			L-3	2.50	2.55	1.55	2.50	2.62	0.67	2.00	2.05	0.61	21.2	No(d)	Yes
7	5x22	429245	L-1	2.50	2.56	1.97	2.50	2.62	0.73	2.02	0.67	26.0	Yes	Yes	
			L-2	2.50	2.61	2.02	2.50	2.56	0.77	2.00	2.70	0.87	27.4	Yes	Yes
			L-3	2.50	2.61	2.02	1.50(h)	1.54	0.81	2.00	2.05	0.88	26.1	Yes	Yes

(a) Average of valid K_{Ic} values.
 (b) Specimen not thick enough. $[2.5(K_{Ic}/\sigma)^2 > \text{thickness}]$
 (c) Fatigue crack too short. $[2.5(K_{Ic}/\sigma)^2 > \text{crack length}]$
 (d) σ_f greater than 0.6 σ_u for the last step of fatigue cracking.
 (e) σ_f greater than 0.7 σ_u for the last step of fatigue cracking.
 (f) Ratio of maximum load to 5% secant load greater than 1.1. However, P_{max}/P₅ is in meaningful range of 1.105 to 1.200.
 (g) Crack length to specimen width ratio not between 0.45 and 0.55.
 (h) Retest results.

TABLE 26

Rates of Fatigue-Crack Propagation (a)

Product	Thickness or Size (in.)	Sample No.	Orientation	Fig.	$\Delta a/\Delta N$ at Indicated ΔK (b)						
					DPV Air 4	DPV Air 7	Moist Air 7	Moist Air 12	Moist Air 12	Sump Meter 4	
2048-T851 Plate	1	421108	L-T	31	0.9	7					
			T-L	32	1.4	13	3.0	16	.6	4.2	13
			L-T	33	1.4	6.5				4.4	17
			S-L	34, 35, 36	.19	1.2	12	5.2	25	.36	3.3
7050-T7351 Plate	2	421074	L-T	37	1.8						
			T-L	38	2.4	15	3.6	19	0.85	9.0	35
			L-T	39	1.6	12				7.2	38
			S-L	40, 41, 42	1.7	16	3.2	22		8.0	32
7475-T7351 Plate	1	429338	L-T	43	1.4	12					
			T-L	44	1.4	11	4.0	22		9.5	40
			L-T	45	1.0	10				8.2	41
			S-L	46, 47, 48	.18	1.1	10	4.2	25	0.8	7.2
7475-T7351 Plate (Current Practice)	3/4 3-1/2	478718 479961	L-T	49	0.7	8					
			T-L	50, 51	.14	6.8				9.0	35
			S-L	52	.56	1.8	14			9.0	38
			L-T	53		1.2	10			3.6	16
2219-T852 Hand Forging	2x3	429246	L-T	54	1.5	16	2.3	22		3.7	21
			T-L	55	1.2	10				2.9	10
			L-T	56	1.3	15	3.0	28		4.7	42
			S-L	56, 57, 58	.15	2.1	18	3.8	33		5.5
Reference Material 7050-T7351 Plate	1 6		T-L	(c)	1.8	19	4.2	24			
			L-T	(c)	1.2	14	2.6	20			
			T-L	(c)	1.4	14	2.6	29			
			S-L	(c)	1.5	11	2.6	28			
2124-T851 Plate	4-1/2		T-L	(d)	2.5	12	4.0	25			
7050-T73652 Hand Forging	2-1/2x22 7-1/2x22		T-L	(c)	1.9	19	1.5	26			
			L-T	(c)	.2	5	3.3	10			
			L-T	(c)	1.8	100	4.4	140			
			S-L	(c)	1.9	>200	5.0	>300			
7175-T736 Hand Forging	5x20		T-L	(d)	3.5	24	7.0	40			

(a) Average rates for tests at about 20 Hz.

(b) ksi/ $\sqrt{\text{in.}}$.

(c) Ref. 10

(d) Ref. 9

TABLE 27

RESULTS OF TESTS TO EVALUATE THE RESISTANCE TO EXFOLIATION OF SAMPLES OF 2219-T852
HAND FORGINGS
(F33615-74-C-5089)

Dimensions Inches	Number	EXCO (a)		MASTMAASIS (b)		Point Judith	
		T/10	T/2	T/10	T/2	T/10	T/2
2.0 x 8	429246	E-A	E-A	---	---	---	---
2.5 x 22	478817	E-D(e)	E-D(e)	P	P	(d)	(d)
3.5 x 14	429512	P	E-A	---	---	---	---
3.5 x 22	429513	E-A	E-A	---	---	---	---
4.5 x 22	429249	E-A	E-A	P	P	(c)	(c)
4.5 x 22	429514	E-A	E-A	---	---	---	---
5.5 x 22	429247	E-A	P	---	---	---	---
5.5 x 22	429248	E-A	E-A	---	---	---	---
7.5 x 22	429744	E-A	E-A	---	---	---	---
7.5 x 22	429245	P	P	P	P	(c)	(c)

Notes: (a) Total immersion for 144 hours in an acidified chloride-nitrate solution (4 N NaCl + 0.5 N KNO₃ + 0.1 N HNO₃ at pH 0.4) ASTM G34-72.

(b) Exposed for 4 weeks in acidified salt spray test MIL-A-8978, 8979, and 8980.

(c) Exposed to the seacoast atmosphere at Point Judith, Rhode Island, 8/20/75.

(d) Exposed to the seacoast atmosphere at Point Judith, Rhode Island, 3/28/77.

(e) Total immersion of 48 hours in acidified chloride-nitrate solution (4 N NaCl + 0.5 N HNO₃ + 0.1 N HNO₃ at 0.4) ASTM G34-72.

TABLE 28

RESULTS OF TESTS TO EVALUATE THE RESISTANCE TO EXFOLIATION OF SAMPLES OF 7050-T7351 ALLOY PLATE

Thickness Inches	Sample Number	EXCO (a)				MASTMAASIS (b)		Point Judith
		T/10 Electrical Conductivity (% IACS)	Results	T/2 Electrical Conductivity (% IACS)	Results	T/10	T/2	
2.000	421074	41.9	P	42.7	P	P	(c)	
2.000	421075	42.2	P	43.0	P	---	---	
3.000	421076	41.5	P	42.5	P	---	---	
3.000	421081	41.6	P	42.5	P	---	---	
4.000	421077	41.5	P	42.6	P	P	(c)	
4.000	421078	41.6	P	42.6	P	---	---	
5.118	421278	40.5	P	41.7	P	P	(c)	
5.000	421073	41.4	P	42.6	P	---	---	
6.000	421079	41.7	P	42.4	P	P	(c)	
6.000	421080	41.3	P	42.4	P	---	---	

(a) Total immersion for 96 hours in an acidified chloride-nitrate solution (4 N NaCl + 0.5 N KNO₃ + 0.1 N HNO₃ at pH 0.4) ASTM G34-72.

(b) Exposed for 4 weeks in acidified salt spray test MIL-A-8978, 8979, and 8980.

(c) Exposed to the seacoast atmosphere at Point Judith, Rhode Island 5/14/76.

TABLE 29
RESULTS OF TESTS TO EVALUATE THE RESISTANCE TO EXFOLIATION OF SAMPLES OF 2048-T851 ALLOY PLATE

Thickness Inches	Sample Number	EXCO (a)				MASTMAASIS (b) T/10 T/2	Point Judith T/10 T/2
		T/10		T/2			
		Electrical Conductivity (% IACS)	Results	Electrical Conductivity (% IACS)	Results		
0.500	421378	40.6	P	40.8	P	---	---
0.500	421379	41.0	P	41.4	P	---	---
1.000	421380	40.5	P	41.0	P	P	(c)
1.000	421108	41.0	P	41.2	P	---	---
2.000	421381	41.0	P	41.3	P	P	(c)
2.000	421382	41.0	P	41.3	P	---	---
3.000	421083	41.6	P	41.8	P	---	---
3.000	421084	42.0	P	42.2	P	---	---
4.000	421383	41.2	P	41.6	P	P	(c)
4.000	421384	41.4	P	41.7	P	---	---

(a) Total immersion for 96 hours in an acidified chloride-nitrate solution (4 N NaCl + 0.5 KNO₃ + 0.1 N HNO₃ at pH 0.4) ASTM G34-72.

(b) Exposed for 4 weeks in acidified salt spray test MIL-A-8978, 8978, and 8980.

(c) Exposed to the seacoast atmosphere at Point Judith, Rhode Island 5/14/76.

TABLE 30
RESULTS OF TESTS TO EVALUATE THE RESISTANCE TO EXFOLIATION OF
SAMPLES OF 7475-T7351 ALLOY PLATE

Thickness Inches	Sample Number	EXCO (a)						MASTMAASIS (b)		Point Judith T/10 T/2
		T/10			T/2			T/10	T/2	
		Elect. Cond. & IACS	Results	Elect. Cond. & IACS	Results	Results				
0.50	429422	41.3	P	42.1	E-A	E-A	---	---	---	
0.500	429423	41.3	P	41.8	E-A	E-A	---	---	---	
1.000	429387	41.9	P	42.8	E-A	E-A	---	---	---	
1.000	429388	41.6	P	42.6	E-A	E-A	P	P	(c)	
2.000	429389	41.9	P	42.8	E-A	E-A	P	P	(c)	
2.000	429390	41.7	P	42.9	E-A	E-A	---	---	---	
3.000	429391	41.5	P	42.7	E-A	E-A	---	---	---	
3.000	429392	41.9	P	42.8	E-A	E-A	---	---	---	
4.000	429393	41.6	P	42.7	E-A	E-A	P	P	(c)	
4.000	429394	41.8	P	42.7	E-A	E-A	---	---	---	

Notes (a) Total immersion for 96 hours in an acidified chloride-nitrate solution
(4N NaCl + 0.5N KNO₃ + 0.1N HNO₃ at pH 0.4) ASTM G34-72.

(b) Exposed for 4 weeks in acidified salt spray test MIL-A-8978, 8979, and 8980.

(c) Exposed to seacoast atmosphere at Point Judith, Rhode Island on July 11, 1975.

TABLE 31
RESULTS OF STRESS-CORROSION TESTING OF 0.125-INCH DIAMETER TENSION SPECIMENS OF 2219-T852 ALLOY HAND FORGINGS
BY ALTERNATE IMMERSION IN A 3.5% SODIUM CHLORIDE SOLUTION FOR 84 DAYS (AS-TM G44-75)

Hand Forgings Dimensions	Longitudinal Tension Specimens				Long-Transverse Tension Specimens				Short-Transverse Tension Specimens			
	Applied Stress ksi	Failure F/N (a)	Failure Days (b)	Average % Loss in Tensile Properties of Unfailed Specimens Yield El.	Applied Stress ksi	Failure F/N (a)	Failure Days (b)	Average % Loss in Tensile Properties of Unfailed Specimens Yield El.	Applied Stress ksi	Failure F/N (a)	Failure Days (b)	Average % Loss in Tensile Properties of Unfailed Specimens Yield El.
2.0 x 8	0	0/2	**	15	0	0/2	**	17	0	0/2	**	29
429246	37	0/3	***	18	37	0/3	***	18	37	0/3	***	20
2.0 x 8				20				33				28
429246												57
2.5 x 22	0	0/2	**	17	0	0/2	**	22	0	0/2	**	26
478817	37	0/3	***	17	37	0/3	***	14	25	0/3	***	21
2.5 x 22				19				13				29
478817				48				20				75
2.5 x 22												27
478817												75
3.5 x 14												30
429512												45
3.5 x 14												23
429512												26
3.5 x 14												22
429512												25
3.5 x 22												27
429513												40
3.5 x 22												56
429513												27
3.5 x 22												30
429513												56
4.5 x 22												29
429249												45
4.5 x 22												24
429249												40
4.5 x 22												27
429249												34
4.5 x 22												40
429514												60
4.5 x 22												29
429514												45
4.5 x 22												24
429514												26
4.5 x 22												27
429514												34
5.5 x 22												40
429247												60
5.5 x 22												29
429247												45
5.5 x 22												24
429247												40
5.5 x 22												27
429247												34
5.5 x 22												40
429248												60
5.5 x 22												30
429248												34
5.5 x 22												49
429248												41
5.5 x 22												31
429248												41
7.5 x 22	0	**	**	17	0	0/2	**	27	0	0/2	**	30
429244	29	**	**	14	29	0/3	***	21	20	0/3	***	24
7.5 x 22				14				21				32
429244				33				0				38
7.5 x 22												24
429244												31
7.5 x 22												23
429244												31
7.5 x 22												41
429245												69
7.5 x 22												30
429245												41
7.5 x 22												22
429245												38
7.5 x 22												24
429245												31
7.5 x 22												23
429245												31
7.5 x 22												41
429245												59
7.5 x 22												24
429245												31
7.5 x 22												22
429245												28
7.5 x 22												47
429245												24
7.5 x 22												47
429245												24

Notes: (a) F/N denotes number of failures over total number of specimens tested.

(b) For day to failure

* Indicates that the specimen did not fail during the 84 day test

+ Indicates that the specimen completed the 84 day test but suffered mechanical type failure during removal from the testing fixture.

(c) Specimen failed in tensile test prior to reaching 0.2% offset.

TABLE 32

RESULTS OF STRESS-CORROSION TESTING OF 0.125-INCH DIAMETER TENSION SPECIMENS OF 7050-T7351 ALLOY PLATE BY ALTERNATE IMMERSION IN 3.5% SODIUM CHLORIDE SOLUTION FOR 84 DAYS (ASTM G44-75)

Plate Thick. In.	Sample Number	Longitudinal Tension Specimens				Long-Transverse Tension Specimens				Short-Transverse Tension Specimens			
		Applied Stress ksi	F/N (a)	Days to Failure (b)	Average % Loss in Tensile Properties of Unfailed Specimens Yield Ult.	Applied Stress ksi	F/N (a)	Days to Failure (b)	Average % Loss in Tensile Properties of Unfailed Specimens Yield Ult.	Applied Stress ksi	F/N (a)	Days to Failure (b)	Average % Loss in Tensile Properties of Unfailed Specimens Yield Ult.
2.000	421074	0	0/2	**	20	0	0/2	**	24	0	0/2	**	33
2.000	421074	46	0/3	***	30	45	0/3	***	38	32	0/3	***	51
2.000	421074									47	0/3	***	47
2.000	421075	0	0/2	**	20	0	0/2	**	24	0	0/2	**	32
2.000	421075	46	0/3	***	36	46	0/3	***	42	32	0/3	***	34
2.000	421075									47	1/3	84,**	44(c)
3.000	421076	0	0/2	**	25	0	0/2	**	28	0	0/2	**	28
3.000	421076	46	0/3	***	36	46	0/3	***	42	32	0/3	***	47(d)
3.000	421076									47	0/3	***	67(d)
3.000	421081	0	0/2	**	25	0	0/2	**	28	0	0/2	**	33
3.000	421081	46	0/3	***	33	46	0/3	***	42	32	0/3	***	49
3.000	421081									47	0/3	***	53
4.000	421077	0	0/2	**	20	0	0/2	**	24	0	0/2	**	30
4.000	421077	46	0/3	***	34	45	0/3	***	38	31	0/3	***	40
4.000	421077									46	0/3	***	49
4.000	421078	0	0/2	**	25	0	0/2	**	28	0	0/2	**	28
4.000	421078	46	0/3	***	39	46	0/3	***	42	31	0/3	***	46
4.000	421078									46	3/3	76,78,84	---
5.000	421073	0	0/2	**	25	0	0/2	**	28	0	0/2	**	30
5.000	421073	44	0/3	***	33	44	0/3	***	41(c)	30	0/3	***	38
5.000	421073									44	1/3	84,**	(d)
5.118	421278	0	0/2	**	31	0	0/2	**	32	0	0/2	**	32
5.118	421278	43	0/3	***	38	43	0/3	***	42	29	0/3	***	38
5.118	421278									43	0/3	***	46
6.000	421079	0	0/2	**	31	0	0/2	**	32	0	0/2	**	32
6.000	421079	43	0/3	***	45	43	0/3	***	48	29	0/3	***	36
6.000	421079									43	0/3	***	45
6.000	421080	0	0/2	**	33	0	0/2	**	33	0	0/2	**	33
6.000	421080	43	0/3	***	47	43	0/3	***	54	29	0/3	***	36
6.000	421080									43	1/3	64,**	47

Notes: (a) F/N denotes number of failures over total number of specimens tested.
 (b) For day to failure, * indicates that the specimen did not fail during the 84 day test.
 (c) One specimen failed in tension test prior to reaching 0.2% offset.
 (d) Two specimens failed in tension test prior to reaching 0.2% offset.

TABLE 33
 RESULTS OF STRESS-CORROSION TESTING OF C.125-INCH DIAMETER TENSION SPECIMENS OF 2048-T851 ALLOY PLATE BY ALTERNATE
 IMMERSION IN A 3.5% SODIUM CHLORIDE SOLUTION FOR 84 DAYS (ASTM G-14-75)

Plate Thick. Sample In. Number	Longitudinal Tension Specimens					Long-Transverse Tension Specimens					Short-Transverse Tension Specimens				
	Applied Stress		Days to Failure		Loss in Tensile Properties of Unfailed Specimens	Applied Stress		Days to Failure		Loss in Tensile Properties of Unfailed Specimens	Applied Stress		Days to Failure		Loss in Tensile Properties of Unfailed Specimens
	ksi	F/N (a)	(b)	Yield		Yield	Ult.	ksi	F/N (a)		(b)	Yield	Ult.	ksi	
1.000 421108	0	0/2	**	17	16	0	0/2	**	17	17	0	0/2	**	17	17
1.000 421108	42	0/3	***	15	14	42	0/3	***	14	14	28	0/3	***	17	18
1.000 421380	0	0/2	**	17	17	0	0/2	**	16	16	42	2/3	26(c),	54	54
1.000 421380	42	0/3	***	16	15	42	0/3	***	14	15	42	2/3	47,*	---	---
2.000 421381	0	0/2	**	17	17	0	0/2	**	18	22	0	0/2	**	18	22
2.000 421381	42	0/3	***	15	14	42	0/3	***	14	14	28	0/3	***	19	21
2.000 421382	0	0/2	**	17	17	0	0/2	**	16	16	42	3/3	9(c),33,	---	---
2.000 421382	42	0/3	***	16	15	42	0/3	***	14	15	42	3/3	63	---	---
3.000 421083	0	0/2	**	19	17	0	0/2	**	19	20	0	0/2	**	20	33
3.000 421083	41	0/3	***	17	16	41	0/3	***	17	19	28	2/3	46,84,*	---	17
3.000 421083	41	0/3	***	17	16	41	0/3	***	17	19	41	3/3	29,76(c)	---	---
3.000 421084	0	0/2	**	19	17	0	0/2	**	19	20	0	0/2	**	20	21
3.000 421084	41	0/3	***	17	16	41	0/3	***	17	19	28	0/3	***	19	20
3.000 421084	41	0/3	***	17	16	41	0/3	***	17	19	41	2/3	77,84,*	20	21
4.000 421383	0	0/2	**	23	21	0	0/2	**	19	20	0	0/2	**	20	22
4.000 421383	41	0/3	***	23	21	41	0/3	***	17	19	28	0/3	***	18	20
4.000 421384	0	0/2	**	23	21	0	0/2	**	19	20	41	1/3	68,**	29	36
4.000 421384	41	0/3	***	23	21	41	0/3	***	18	19	41	1/3	68,**	29	36
4.000 421384	41	0/3	***	23	21	41	0/3	***	18	19	41	1/3	53(c),**	29	35
4.000 421384	41	0/3	***	23	21	41	0/3	***	18	19	41	1/3	53(c),**	29	35

Notes: (a) F/N denotes number of failures over total number of specimens tested.
 (b) For day to failure, * indicates that the specimen did not fail during the 84 day test.
 (c) Metallographically examined.

TABLE 34
 RESULTS OF STRESS-CORROSION TESTING OF 0.125-INCH DIAMETER TENSION SPECIMENS OF 7475-T7351 ALLOY PLATE BY ALTERNATE
 IMMERSION IN A 3.5% SODIUM CHLORIDE SOLUTION FOR 84 DAYS (ASTM G44-75)

Plate Thick. Inch	Sample Number	Longitudinal					Long-Transverse					Short-Transverse							
		Applied Stress Ksi	Failure Data		Average %		Applied Stress Ksi	Failure Data		Average %		Applied Stress Ksi	Failure Data		Average %				
			F/N (a)	Days to Failure (b)	Loss in Tensile Properties of Unfailed Specimens Yield Ult.	EL.		F/N (a)	Days to Failure (b)	Loss in Tensile Properties of Unfailed Specimens Yield Ult.	EL.		F/N (a)	Days to Failure (b)	Loss in Tensile Properties of Unfailed Specimens Yield Ult.	EL.			
1.000	429387	0	0/2	**	13	12	44	0	0/2	**	16	16	70	0	0/2	**	19	18	35
1.000	429387	43	0/3	***	15	15	37	43	0/3	***	16	18	64	28	0/3	***	24	28	68
1.000	429388	0	0/2	**	13	11	27	0	0/2	**	15	14	48	42	0/3	***	26	26	74
1.000	429388	43	0/3	***	13	14	51	43	0/3	***	14	15	56	42	0/3	***	24	26	74
2.000	429389													0	0/2	**	21	19	49
2.000	429389													28	0/3	***	24	26	74
2.000	429390													42	0/3	***	40	49	74
2.000	429390													0	0/2	**	15	18	50
3.000	429391													26	0/3	***	16	19	50
3.000	429391													39	0/3	***	20	28	75
3.000	429392													0	0/2	**	19	21	50
3.000	429392													26	0/3	***	17	21	50
3.000	429392													39	0/3	***	21	37	100
4.000	429393	0	0/2	**	6	7	47	0	0/2	**	13	13	45	0	0/2	**	25	22	51
4.000	429393	36	0/3	***	6	7	56	36	0/3	***	14	15	45	24	0/3	***	20	17	51
4.000	429393													36	0/3	***	18	24	51
4.000	429394	0	0/2	**	9	10	61	0	0/2	**	14	16	44	0	0/2	**	18	22	47
4.000	429394	36	0/3	***	8	10	61	36	0/3	***	15	20	44	24	0/3	***	16	22	47
4.000	429394													36	0/3	***	18	26	73

Notes: (a) F/N denotes number of failures over total number of specimens tested.

(b) For day to failure

* indicates that the specimen did not fail during the 84 day test.

+ indicates that the specimen completed the 84 day test but fractured during removal from the testing fixture.

TABLE 35

RESULTS OF STRESS-CORROSION TESTS OF 0.125-INCH DIAMETER SHORT-TRANSVERSE TENSION SPECIMENS OF 2219-T852 ALLOY HAND FORGINGS IN OUTDOOR ATMOSPHERES

Size Inches	Sample Number	Applied Stress ksi	Point Judith Seacoast Atmos.		ATC Industrial Atmos.	
			F/N(a)	Days to Failure	F/N(a)	Days to Failure
2.0 x 8	429246	0	0/2	OK 492 days	0/2	OK 496 days
		25	0/3	OK 492 days	0/3	OK 496 days
		37	0/3	OK 492 days	0/3	OK 496 days
2.5 x 22	478817	0	0/2	(b)	0/2	OK 24 days
		25	0/3	(b)	0/3	OK 24 days
		37	0/3	(b)	0/3	OK 24 days
3.5 x 14	429512	0	0/2	OK 492 days	0/2	OK 496 days
		25	0/3	OK 492 days	0/3	OK 496 days
		37	0/3	OK 492 days	0/3	OK 496 days
3.5 x 22	429513	0	0/2	OK 492 days	0/2	OK 496 days
		25	0/3	OK 492 days	0/3	OK 496 days
		37	0/3	OK 492 days	0/3	OK 496 days
4.5 x 22	429249	0	0/2	OK 492 days	0/2	OK 496 days
		21	0/3	OK 492 days	0/3	OK 496 days
		32	0/3	OK 492 days	0/3	OK 496 days
4.5 x 22	429514	0	0/2	OK 492 days	0/2	OK 496 days
		21	0/3	OK 492 days	0/3	OK 496 days
		32	0/3	OK 492 days	0/3	OK 496 days
5.5 x 22	429247	0	0/2	OK 492 days	0/2	OK 496 days
		21	0/3	OK 492 days	0/3	OK 496 days
		32	0/3	OK 492 days	0/3	OK 496 days
5.5 x 22	429248	0	0/2	OK 492 days	0/2	OK 496 days
		21	0/3	OK 492 days	0/3	OK 496 days
		32	0/3	OK 492 days	0/3	OK 496 days
7.5 x 22	429244	0	0/2	OK 492 days	0/2	OK 496 days
		21	0/3	OK 492 days	0/3	OK 496 days
		25	0/3	OK 492 days	0/3	OK 496 days
7.5 x 22	429245	0	0/2	OK 492 days	0/2	OK 496 days
		20	0/3	OK 492 days	0/3	OK 496 days
		29	0/3	OK 492 days	0/3	OK 496 days

(a) F/N denotes number of failures over total number of specimens exposed.

(b) Exposed to the seacoast atmosphere at Point Judith, Rhode Island, 3/28/77.

TABLE 36

RESULTS OF STRESS-CORROSION TESTS OF 0.125-INCH DIAMETER SHORT-TRANSVERSE TENSION SPECIMENS OF 7050-T7351 ALLOY PLATES IN OUTDOOR ATMOSPHERES

Thickness Inches	Sample Number	Applied Stress ksi	Point Judith Seacoast Atmos.		ATC Industrial Atmos.	
			F/N(a)	Days to Failure	F/N(a)	Days to Failure
2.0	421074	0	0/2	OK 288 days	0/2	OK 322 days
		32	0/3	OK 288 days	0/3	OK 322 days
		47	0/3	OK 288 days	0/3	OK 322 days
2.0	421075	0	0/2	OK 288 days	0/2	OK 322 days
		32	0/3	OK 288 days	0/3	OK 322 days
		47	0/3	OK 288 days	0/3	OK 322 days
3.0	421076	0	0/2	OK 288 days	0/2	OK 322 days
		32	0/3	OK 288 days	0/3	OK 322 days
		47	0/3	OK 288 days	0/3	OK 322 days
3.0	421081	0	0/2	OK 288 days	0/2	OK 322 days
		32	0/3	OK 288 days	0/3	OK 322 days
		47	0/3	OK 288 days	0/3	OK 322 days
4.0	421077	0	0/2	OK 288 days	0/2	OK 322 days
		31	0/3	OK 288 days	0/3	OK 322 days
		46	0/3	OK 288 days	0/3	OK 322 days
4.0	421078	0	0/2	OK 288 days	0/2	OK 322 days
		31	0/3	OK 288 days	0/3	OK 322 days
		46	0/3	OK 288 days	0/3	OK 322 days
5.0	421073	0	0/2	OK 288 days	0/2	OK 322 days
		30	0/3	OK 288 days	0/3	OK 322 days
		44	0/3	OK 288 days	0/3	OK 322 days
5.118	421278	0	0/2	OK 288 days	0/2	OK 322 days
		29	0/3	OK 288 days	0/3	OK 322 days
		43	0/3	OK 288 days	0/3	OK 322 days
6.0	421079	0	0/2	OK 288 days	0/2	OK 322 days
		29	0/3	OK 288 days	0/3	OK 322 days
		43	0/3	OK 288 days	0/3	OK 322 days
6.0	421080	0	0/2	OK 288 days	0/2	OK 322 days
		29	0/3	OK 288 days	0/3	OK 322 days
		43	0/3	OK 288 days	0/3	OK 322 days

(a) F/N denotes number of failures over total number of specimens exposed.

TABLE 37
RESULTS OF STRESS-CORROSION TESTS OF 0.125-INCH DIAMETER SHORT-TRANSVERSE TENSION
SPECIMENS OF 2048-T851 ALLOY PLATES IN OUTDOOR ATMOSPHERES

Thickness Inches	Sample Number	Applied Stress ksi	Point Judith Seacoast Atmos.		ATC Industrial Atmos.	
			F/N(2)	Days to Failure	F/N(a)	Days to Failure
2.0	421381	0	0/2	OK 288 Days	0/2	OK 260 Days
		28	0/3	OK 288 Days	0/3	OK 260 Days
		42	2/3	71, 128, OK 288 Days	0/3	OK 260 Days
2.0	421382	0	0/2	OK 288 days	0/2	OK 260 days
		28	0/3	OK 288 days	0/3	OK 260 days
		42	1/3	71, 2 OK 288 days	0/3	OK 260 days
3.0	421083	0	0/2	OK 288 days	0/2	OK 260 days
		28	0/3	OK 288 days	0/3	OK 260 days
		41	2/3	73, 128, 1 OK 288 days	0/3	OK 260 days
3.0	421084	0	0/2	OK 288 days	0/2	OK 260 days
		28	0/3	OK 288 days	0/3	OK 260 days
		41	0/3	OK 288 days	0/3	OK 260 days
4.0	421383	0	0/2	OK 288 days	0/2	OK 260 days
		28	0/3	OK 288 days	0/3	OK 260 days
		41	0/3	OK 288 days	0/3	OK 260 days
4.0	421384	0	0/2	OK 288 days	0/2	OK 260 days
		28	0/3	OK 288 days	0/3	OK 260 days
		41	0/3	OK 288 days	0/3	OK 260 days

(a) F/N denotes number of failure over total number of specimens tested.

TABLE 38

RESULTS OF STRESS-CORROSION TESTS OF 0.125-INCH DIAMETER SHORT-TRANSVERSE TENSION SPECIMENS OF 7475-T7351 ALLOY PLATES IN OUTDOOR ATMOSPHERES

Thickness Inches	Sample Number	Applied Stress ksi	Point Judith Seacoast Atmos.		ATC Industrial Atmos.	
			F/N(a)	Days to Failure	F/N(a)	Days to Failure
2.0	429389	0	0/2	OK 617 days	0/2	OK 622 days
		28	0/3	OK 617 days	0/3	OK 622 days
		42	0/3	OK 617 days	0/3	OK 622 days
2.0	429390	0	0/2	OK 617 days	0/2	OK 622 days
		28	0/3	OK 617 days	0/3	OK 622 days
		42	0/3	OK 617 days	0/3	OK 622 days
3.0	429391	0	0/2	OK 617 days	0/2	OK 622 days
		26	0/3	OK 617 days	0/3	OK 622 days
		39	0/3	OK 617 days	0/3	OK 622 days
3.0	429392	0	0/2	OK 617 days	0/2	OK 622 days
		26	0/3	OK 617 days	0/3	OK 622 days
		39	0/3	OK 617 days	0/3	OK 622 days
4.0	429393	0	0/2	OK 617 days	0/2	OK 622 days
		24	0/3	OK 617 days	0/3	OK 622 days
		36	0/3	OK 617 days	0/3	OK 622 days
4.0	429394	0	0/2	OK 617 days	0/2	OK 622 days
		24	0/3	OK 617 days	0/3	OK 622 days
		36	0/3	OK 617 days	0/3	OK 622 days

(a) F/N denotes number of failures over total number of specimens exposed.

TABLE 39
RESULTS OF INITIAL STRESS INTENSITY, K_{I1} , LOADS OF DOUBLE CANTILEVER
BEAM SPECIMENS

Alloy & Temper	Sample Thick. In.	Number	S-L (a) K_{I1} ksi $\sqrt{\text{In.}}$	Product	3 1/2% NaCl Solution-Dropwise				Point Judith Seacoast Atmos.				ATC Industrial Atmos.			
					Dash Number	Crack Length In.	Total V(c) In.	S-L K_{I1} (b) ksi $\sqrt{\text{In.}}$	Dash Number	Crack Length In.	Total V (c) In.	S-L K_{I1} (b) ksi $\sqrt{\text{In.}}$	Dash Number	Crack Length In.	Total V (c) In.	S-L K_{I1} (b) ksi $\sqrt{\text{In.}}$
2048-T851	2	421381	24.9	Plate	1	1.332	0.055	30.7	5	1.260	0.044	26.5	3	1.319	0.042	23.8
					2	1.339	0.052	28.8	6	1.282	0.043	25.8	4	1.348	0.045	24.4
2048-T851	4	421383	25.5	Plate	1	1.363	0.053	28.3	5	1.272	0.043	25.5	3	1.304	0.043	24.0
					2	1.405	0.050	25.7	6	1.276	0.044	25.9	4	1.298	0.043	25.0
7050-T7351	2	421074	27.0	Plate	1	1.366	0.059	31.4	5	1.224	0.043	27.1	3	1.309	0.045	25.3
					2	1.362	0.052	27.8	6	1.217	0.046	29.5	4	1.258	0.041	24.8
7050-T7351	4	421077	29.0	Plate	1	1.302	0.049	28.1	5	1.147	0.043	29.8	3	1.161	0.038	25.9
					2	1.261	0.047	28.3	6	1.190	0.043	28.6	4	1.170	0.041	27.3
7050-T7351	6	421079	29.4	Plate	1	1.315	0.044	25.1	5	1.146	0.041	28.1	3	1.292	0.045	26.1
					2	1.231	0.042	26.3	6	1.134	0.037	26.2	4	1.156	0.039	26.8
7050-T7351	6	421083	26.5	Plate	1	1.196	0.036	23.5	5	1.170	0.036	24.3	3	1.276	0.039	23.0
					2	1.203	0.039	25.2	6	1.196	0.035	22.5	4	1.123	0.038	24.3
7475-T7351	2	429389	28.7	Plate	1	1.345	0.055	29.9	5	1.315	0.048	27.1	3	1.284	0.047	27.5
					2	1.292	0.053	31.0	6	1.303	0.048	27.4	4	1.320	0.047	26.3
7475-T7351	4	429393	31.0	Plate	1	1.373	0.056	29.3	5	1.283	0.055	32.2	3	1.297	0.054	31.1
					2	1.266	0.052	31.1	6	1.285	0.056	32.8	4	1.289	0.056	32.3
2219-T852	2.5	479817	21.7	Hand Forging	1	1.331	0.038	20.6	5	1.327	0.039	21.5	3	1.300	0.040	22.7
					2	1.272	0.036	21.2	6	1.324	0.038	20.7	4	1.338	0.041	22.0
2219-T852	4.5	429249	23.7	Hand Forging	1	1.284	0.038	22.0	5	1.362	0.041	21.6	3	1.263	0.045	26.7
					2	1.283	0.039	22.3	6	1.393	0.046	23.7	4	1.305	0.046	26.0
2219-T852	7.5	429245	26.1	Hand Forging	1	1.406	0.040	20.4	5	1.337	0.043	23.4	3	1.350	0.038	20.6
					2	1.387	0.041	21.3	6	1.263	0.041	24.1	4	1.386	0.042	21.4

(a) Average short-transverse plane strain fracture toughness tests.

(b) Short-transverse initial stressed intensity calculations.

(c) Total crack opening displacement - V.

TABLE 40

AVERAGE CRACK GROWTH VELOCITIES FOR DOUBLE CANTILEVER BEAM SPECIMENS EXPOSED TO 3.5% NaCl SOLUTION DROPPWISE FOR 30 DAYS

Alloy & Temper	Number	Dash	Product	Thickness In.	K _I Ksi/In.	K _I 15 Da. Ksi/In.	K _I 20 Da. Ksi/In.	Avg. 15 Day Velocity In/Hr (a)	Mean Velocity In/Hr (a)	K _I th (BST)	
2219-T852	478817	SL1	Hand Forging	2.5	20.6	19.6	19.1	1.19 x 10 ⁻⁴	1.6 x 10 ⁻⁴	19.4	93
2219-T852	478817	SL2	Hand Forging	2.5	21.2	19.7	19.6	1.75 x 10 ⁻⁴			
2219-T852	429249	SL1	Hand Forging	4.5	22.0	21.7	19.6	3.89 x 10 ⁻⁵ (b)	6.1 x 10 ⁻⁵ (b)	20.5 (b)	93 (b)
2219-T852	429249	SL2	Hand Forging	4.5	22.3	21.6	21.4	8.3 x 10 ⁻⁵ (b)			
2219-T852	429245	SL1	Hand Forging	7.5	20.4	19.6	19.6	9.72 x 10 ⁻⁵ (b)	5.6 x 10 ⁻⁵ (b)	20.4 (b)	98 (b)
2219-T852	429245	SL2	Hand Forging	7.5	21.3	21.2	21.2	1.39 x 10 ⁻⁵ (b)			
2048-T851	421381	SL1	Plate	2	30.7	24.4	22.1	5.83 x 10 ⁻⁴	5.8 x 10 ⁻⁴	21.8	73
2048-T851	421381	SL2	Plate	2	28.8	22.9	21.5	5.73 x 10 ⁻⁴			
2048-T851	421383	SL1	Plate	4	28.3	27.0	26.7	1.19 x 10 ⁻⁴	1.0 x 10 ⁻⁴	25.6	95
2048-T851	421383	SL2	Plate	4	25.7	24.8	24.4	8.97 x 10 ⁻⁵			
7050-T7351	421074	SL1	Plate	2	31.4	29.5	29.5	1.53 x 10 ⁻⁴	3.9 x 10 ⁻⁴	28.1	95
7050-T7351	421074	SL2	Plate	2	27.8	27.1	26.7	6.19 x 10 ⁻⁵			
7050-T7351	421077	SL1	Plate	4	28.1	25.7	25.1	2.15 x 10 ⁻⁴	2.4 x 10 ⁻⁴	25.1	89
7050-T7351	421077	SL2	Plate	4	28.3	25.2	25.0	2.68 x 10 ⁻⁴			
7050-T7351	421079	SL1	Plate	6	25.1	24.8	24.7	2.97 x 10 ⁻⁵	2.9 x 10 ⁻⁵	25.2	98
7050-T7351	421079	SL2	Plate	6	26.3	25.9	25.7	2.78 x 10 ⁻⁵			
7050-T7351	421080	SL1	Plate	6	23.5	19.1	18.9	4.78 x 10 ⁻⁴	4.5 x 10 ⁻⁴	19.7	81
7050-T7351	421080	SL2	Plate	6	25.2	21.0	20.5	4.26 x 10 ⁻⁴			
7475-T7351	429389	SL1	Plate	2	30.0	29.7	29.6	2.14 x 10 ⁻⁵	2.7 x 10 ⁻⁵	30.1	99
7475-T7351	429389	SL2	Plate	2	31.0	30.6	30.6	3.29 x 10 ⁻⁵			
7475-T7351	429393	SL1	Plate	4	29.3	29.2	29.2	1.19 x 10 ⁻⁵ (b)	2.2 x 10 ⁻⁵ (b)	29.9 (b)	99 (b)
7475-T7351	429393	SL2	Plate	4	31.1	30.7	30.6	3.28 x 10 ⁻⁵ (b)			

(a) Overall average velocity for the first 15 day exposure.

(b) Presence of actual SCC is questionable based on visual examination.

TABLE 41
 AVERAGE CRACK GROWTH VELOCITIES OF REDUCED THICKNESS DCB SPECIMENS EXPOSED TO 3.5% NaCl SOLUTION
 DROPTISE FOR 30 DAYS

Alloy & Temper.	Specimen		Thick. In.	K _I Ksi/√In.	K _I 15 Da. Ksi/√In.	K _I 20 Da. Ksi/√In.	Avg. 15 Day Velocity In./Hr. (a)	Mean Velocity In./Hr. (b)	K _I (EST) Ksi/√In.	% K _I
	Number	Dash								
2048-T851	421383	SL7(a)	0.25	37.3	35.8	35.6	8.33 x 10 ⁻⁵	9.7 x 10 ⁻⁵	36.5	95
	421383	SL8(a)	0.25	39.3	37.3	37.3	1.11 x 10 ⁻⁴			
	421383	SL9	0.50	28.5	28.2	28.1	2.58 x 10 ⁻⁵	6.3 x 10 ⁻⁵	27.4	97
2048-T851	421383	SL10	0.50	27.9	26.7	26.7	1.01 x 10 ⁻⁴			
	421077	SL7(a)	0.25	38.8	37.3	37.3	8.33 x 10 ⁻⁵	5.6 x 10 ⁻⁵	37.9	97
	421077	SL8(a)	0.25	39.0	38.4	38.4	2.78 x 10 ⁻⁵			
7050-T7351	421077	SL9	0.50	28.3	27.6	27.5	6.11 x 10 ⁻⁵	7.5 x 10 ⁻⁵	27.1	97
	421077	SL10	0.50	27.7	26.6	26.6	8.97 x 10 ⁻⁵			
	429393	SL7(a)	0.25	50.0	48.0	47.6	8.33 x 10 ⁻⁵	4.2 x 10 ⁻⁵	50.4	98
7475-T7351	429393	SL8(a)	0.25	53.2	53.2	53.2	0			
	429393	SL9	0.50	33.4	33.3	33.3	6.94 x 10 ⁻⁶	1.08 x 10 ⁻⁵	34.4	99
	429393	SL10	0.50	35.8	35.5	35.5	1.47 x 10 ⁻⁵	5.0 x 10 ⁻⁵	30.1	98
7475-T7351	429393	SL11	0.80	29.7	29.5	29.3	1.75 x 10 ⁻⁵			
	429393	SL12	0.80	31.9	30.8	30.8	8.25 x 10 ⁻⁵			

(a) Results based on surface measurements only.

(b) Overall average velocity for the first 15 days of exposure.

TABLE 42

RESULTS OF STRESS-CORROSION TESTING OF 0.125-INCH DIAMETER SHORT-TRANSVERSE TENSION SPECIMENS OF 7475-T7351 ALLOY PLATE BY ALTERNATE IMMERSION IN A 3.5% SODIUM CHLORIDE SOLUTION FOR 84 DAYS (ASTM G44-75)

Thickness Inches	Sample Number	Applied Stress ksi	F/N (a)	Days to Failure (b)	Average & Loss in Tensile Properties of Unfailed Specimens		
					Yield	Ult. El.	
2.25	478826	0	0/2	**	18	19	50
		28	0/3	***	26	33	75
		41	0/3	***	35	46	75
3.5	478961	0	0/2	**	21	23	58
		25	0/3	***	21	27	65
		38	0/3	***	27	35	79

(a) F/N denotes number of failures over total number of specimens exposed.

(b) For day to failure

* Indicates that the specimen did not fail during the 84 day test.

TABLE 43

RESULTS OF STRESS-CORROSION TESTS OF 0.125-INCH DIAMETER SHORT-TRANSVERSE TENSION SPECIMENS OF 7475-T7351 ALLOY PLATES IN OUTDOOR ATMOSPHERES

Thickness Inches	Sample Number	Applied Stress ksi	Point Judith Seacoast Atmos.		ATC Industrial Atmos.	
			F/N(a)	Days to Failure	F/N(a)	Days to Failure
2.25	478826	0	/2	(b)	0/2	OK 24 Days
		28	/3	(b)	0/3	OK 24 Days
		41	/3	(b)	0/3	OK 24 Days
3.5	478961	0	/2	(b)	0/2	OK 24 Days
		24	/3	(b)	0/3	OK 24 Days
		38	/3	(b)	0/3	OK 24 Days

(a) F/N denotes number of failures over total number of specimens exposed.

(b) Exposed to the seacoast atmosphere at Point Judith, Rhode Island, 3/28/77.

TABLE 44
RESULTS OF INITIAL STRESS INTENSITY, K_{II} , LOAD OF DOUBLE CANTILEVER BEAM SPECIMENS

Alloy & Temper	Thick. In.	Number	S-I(a) K_{II} ksi√in.	Product	3 1/2% NaCl Solution-Dropwise				Point Judith Seacoast Atmos.				ATC Industrial Atmos.			
					Dash Number	Crack Length In.	Total V(c) In.	S-L K_{II} (b) ksi√in.	Dash Number	Crack Length In.	Total V(c) In.	S-L K_{II} (b) ksi√in.	Dash Number	Crack Length In.	Total V(c) In.	S-L K_{II} (b) ksi√in.
7475-T7351	2.25	478826	33.1	Plate	1	1.2270	0.051	31.7	5	1.3063	0.057	32.7	3	1.2570	0.058	35.1
					2	1.3123	0.054	30.6	6	1.2710	0.056	33.0	4	1.2297	0.054	33.4
7475-T7351	3.5	478961	32.0	Plate	1	1.2453	0.057	35.0	5	1.2230	0.052	32.8	3	1.3300	0.065	36.0
					2	1.2760	0.056	32.9	6	1.2603	0.057	34.6	4	1.2773	0.059	34.8

(a) Average short-transverse plain strain fracture toughness tests.
 (b) Short-transverse initial stress intensity calculations.
 (c) Total crack opening displacements - V.

TABLE 45

AVERAGE CRACK VELOCITIES FOR DOUBLE CANTILEVER BEAM SPECIMENS FROM 7475-T7351 ALLOY PLATES AND EXPOSED TO 3.5% NaCl SOLUTION DROPPWISE

Specimen Number	Dash	Plate Thick. In.	K _I		K _I 15 Day		K _I 20 Day		Average 15 Day Velocity		Mean Velocity In./Hr.	K _I K _{II}
			K _I K _{II}	K _I K _{II}	K _I K _{II}	K _I K _{II}	In./Hr(a)	In./Hr.	K _I K _{II}			
478876	SL1	2.25	31.7	30.5	30.2	30.2	30.2	29.8	8.61 x 10 ⁻⁵	5.9 x 10 ⁻⁵	30.0	96
	SL2	2.25	30.6	30.2	30.2	30.2	29.8	29.8	3.14 x 10 ⁻⁵	5.9 x 10 ⁻⁵	30.0	96
478961	SL1	3.50	35.0	33.7	33.6	33.6	33.6	32.3	3.14 x 10 ⁻⁵	5.9 x 10 ⁻⁵	33.0	97
	SL2	3.50	32.9	32.4	32.3	32.3	32.3	32.3	3.14 x 10 ⁻⁵	5.9 x 10 ⁻⁵	33.0	97

(a) Overall average velocity for the first 15 days of exposure.