

AD-A053 101

MICHIGAN UNIV ANN ARBOR COOLEY ELECTRONICS LAB

F/6 20/1

PANOIC77. PART I. THE PANOIC77 SEQUENCE SIGNAL. PART II. THE PA--ETC(U)

MAR 78 T 6 BIRDSALL, G E BOLD, K A WINICK

N00014-75-C-0175

UNCLASSIFIED

CEL-TR-226

NL

1 OF
AD
A053101

The microfilm frames contain the following content:

- Row 1:** Title page and introductory text.
- Row 2:** Text and a diagram of a sequence signal.
- Row 3:** Text and a diagram of a sequence signal.
- Row 4:** Text and a diagram of a sequence signal.
- Row 5:** Text and a diagram of a sequence signal.
- Row 6:** Text and a diagram of a sequence signal.
- Row 7:** Text and a diagram of a sequence signal.
- Row 8:** Text and a diagram of a sequence signal.
- Row 9:** Text and a diagram of a sequence signal.
- Row 10:** Text and a diagram of a sequence signal.

END
DATE
FILMED
6 -78
DDC

Report 013376-5-T



5

J

AD A 053101

PANOIC77

T.G. Birdsall
K.A. Winick

COOLEY ELECTRONICS LABORATORY
Department of Electrical and Computer Engineering
The University of Michigan
Ann Arbor, Michigan 48109

JUNE 1977 (Issue date: MARCH 1978)

Technical Report No. 228

Approved for public release; distribution unlimited.

Prepared for
OFFICE OF NAVAL RESEARCH
Department of the Navy
Arlington, Virginia 22217

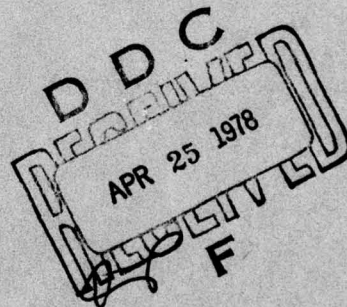

AD No. —
DDC FILE COPY

BEST AVAILABLE COPY

REPORT DOCUMENTATION PAGE		READ INSTRUCTIONS BEFORE COMPLETING FORM	
1. REPORT NUMBER 013376-5-T	2. GOVT ACCESSION NO. (14) CEL-TR-228	3. RECEIPT'S ENTRY NUMBER 013376-5-T	4. TYPE OF REPORT & PERIOD COVERED
6. TITLE (and Subtitle) PAN0IC77 Part I • The PAN0IC77 Sequence Signal Part II • The PAN0IC77 Controller and Signal Generator		5. PERFORMING ORG. REPORT NUMBER TR228	
10. AUTHOR(s) T. G. Birdsall, G. E. J. Bold K. A. Winick		7. CONTRACT OR GRANT NUMBER(s) (15) N00014-75-C-0175	
9. PERFORMING ORGANIZATION NAME AND ADDRESS Cooley Electronics Laboratory University of Michigan Ann Arbor, Michigan 48109		10. PROGRAM ELEMENT, PROJECT, TASK AREA & WORK UNIT NUMBERS	
11. CONTROLLING OFFICE NAME AND ADDRESS Office of Naval Research Department of the Navy Arlington, Virginia 22217		12. REPORT DATE July 1977 Issue date: Mar 1978	
14. MONITORING AGENCY NAME & ADDRESS (if different from Controlling Office)		13. NUMBER OF PAGES 104 (15) 95 p.	
		15. SECURITY CLASS. (of this report)	
		15a. DECLASSIFICATION/DOWNGRADING SCHEDULE	
13. DISTRIBUTION STATEMENT (of this Report) Approved for public release; distribution unlimited.			
17. DISTRIBUTION STATEMENT (of the abstract entered in Block 20, if different from Report)			
18. SUPPLEMENTARY NOTES			
19. KEY WORDS (Continue on reverse side if necessary and identify by block number) PAN0IC77 Acoustic transmission Modulated (SEQ) signal Signal generator Unmodulated (CW) signal			
20. ABSTRACT (Continue on reverse side if necessary and identify by block number) PAN0IC77 is an exercise, a set of scientific measurements, to be conducted in the Pacific Ocean in July through September 1977, hence the initial P. The participants include (A) ARPA, the Defense Advance Research Projects Agency; (N) Naval Oceanographic Office; (O) Office of Naval Research; (I) Institute for Acoustic Research of Miami, Florida, and (C) Cooley Electronics			

097 400

20.

Laboratory of the Electrical and Computer Engineering Department
The University of Michigan. Cooley is responsible for the signal
design, the subject of Part I of this report.

Part II documents the design and operation of the PANOIC77
controller and signal generator. The equipment was designed
specifically for the PANOIC77 experiment. It is both a dual
signal generator, generating an unmodulated (CW) signal at one
frequency and a modulated signal (SEQ) at a different carrier
frequency, and a controller that can cycle through specific on-
off patterns for these signals.



TABLE OF CONTENTS

	<u>Page</u>
PART I: The PANOIC77 Sequence Signal	
1. About PANOIC77	1
2. Design of the PANOIC77 Signal	2
3. Periodic Conjugate Modulation	8
3.1 Periodic Digital Signals	8
3.2 Binary Conjugate Modulation	9
3.3 Linear Maximal Sequences	11
3.4 The Seven-Digit Sequence	12
4. The Slow and Fast Sequence Pair	13
5. Complex Demodulation Matched to an FFT	17
6. Transmission Schedule	21
PART II: The PANOIC77 controller and Signal Generator	
1. Output Waveforms	24
2. Operator's Controls and Frequency Setting	26
2.1 Front Panel Controls on the PANOIC77 Signal Generator	26
2.2 Setting the Frequencies in the PANOIC77 Signal Generator	32
3. Hardware Design	41
3.1 Master Oscillator and Reference Frequency Circuits	42
3.2 CW Signal Generation	45
3.3 SEQ Modulation and Signal Generation	47
3.4 Timing/Control States and State Display	50
3.5 Amplitude Adjustment and Metering	53
APPENDIX	57

LIST OF ILLUSTRATIONS

<u>Figure</u>		<u>Page</u>
1	Front end block diagram	17
2	PANOIC77 Modulating waveforms	25
3	Front panel	27
4	Header locations	33
5	IC-Side view of frequency setting socket	34
6	Divisor headers	35
7	HLF 3 headers	37
8	HX231 headers	38
9	HX137 headers	39
10	Master oscillator and reference frequencies	43
11	CW generator	46
12	SEQ-Modulated signal generator	48
13	Control state circuits with displays	51
14	Level adjustment and metering circuits	54

y

ACCESSION FOR	
NTIS	Write Section <input checked="" type="checkbox"/>
DTIC	Mail Section <input type="checkbox"/>
UNANNOUNCED	<input type="checkbox"/>
AUTHORITY	
BY	
DISTRIBUTION/AVAILABILITY CODES	
DIGL	AVAIL. SER. OR SPECIAL
A	

PART I

The PANOIC77 Sequence Signal

1. About PANOIC77

PANOIC77 is an exercise, a set of scientific measurements, to be conducted in the Pacific Ocean in July through September 1977. The initial P stands for the Pacific. The participants include (A) ARPA, the Defense Advance Research Projects Agency; (N) Naval Oceanographic Office; (O) Office of Naval Research; (I) Institute for Acoustic Research of Miami, Florida; and (C) Cooley Electronics Laboratory (CEL) of the ECE Department, University of Michigan. CEL is responsible for the signal design, the subject of this brief report.

The transmission is acoustic, underwater, in the low audio frequencies, at a modest power level. The ranges from transmitter to receiver will vary from a few nautical miles to thousands of nautical miles. The acoustic transmitter, often called the projector, will be towed through the water, causing the received signal to differ from the transmitted signal (Doppler effect). At all but the shortest ranges, the reception will be a sum of arrivals along several paths (multipath effect), and each of these paths may be a complex of many micro-multipaths; the signal processor may prefer to speak of this as a complicated complex transfer function.

The variety and complexity of the propagation, the desire to make effective measurements at long ranges

with low power, and the desire to take advantage of good signal-to-noise ratio at short ranges, were major considerations in the signal design. A prime consideration was the availability of suitable projectors, at the low frequencies necessary for long-range propagation.

2. Design of the PANOIC77 Signal

High output signal-to-noise ratio is the signal processor's goal in any measurement, and two key elements in obtaining high "snr" are to involve as much received signal energy in each measurement as possible, and to "match" to the received signal in every way possible. In low frequency acoustic transmissions the peak transmission power is frequently limited (as it is in PANOIC77), and this favors continuous signals over pulse (on/off) signals, and favors phase or frequency modulation over amplitude modulation.

In any experiment with repeated measurements the transmission will have to be repeated, and if the repetition of the signal is systematic, periodic, the total signal itself is a periodic signal. If the period is longer than the measurement time, then the processor does not make use of this periodicity; if the period is shorter than the measurement, then the processor may take advantage of the periodicity. This is the logic behind the choice of an intentionally periodic phase-modulated signal for PANOIC77.

The task of matching to a received signal with an unknown (but bounded) Doppler shift, or multipath set of

shifts, is considerably eased if the processor takes advantage of the line nature of a periodic signal's spectrum. Of course, the fact that the transmission is periodic does not mean that the reception will be exactly periodic. Guessing how much of the signal processing should behave as if the signal were precisely periodic is part of the signal processor's art, based on some physics, some experience, and some measure of hope. Spectral analysis, used with care, is the first step in matching to a line spectrum signal.

Conclusion so far: use a periodic signal and use spectral analysis that allows matching to the received signal.

These days spectral analysis means digitization followed by an FFT (Fast Fourier Transform) followed by coherent or incoherent summation or parameter extraction on successive FFT outputs. With this in mind, CEL chose to design the signal so that Doppler and some time-delay information could be extracted from single hydrophone receptions at 2000-nautical mile range based on a 100-watt acoustic source and a standard ocean. (A standard ocean means the type of propagation and noise levels appearing in Urich's book, using no more detailed information except the signal frequency and the fact that the ocean is deep.)

Correct extraction of Doppler is the key to subsequent fancy signal processing, so half of the transmitted power was arbitrarily assigned to the carrier. (It is relatively easy to adjust the ratio of carrier power to

total power.) In conjunction with Dr. Jobst of IAR it was agreed that

(1) a 2.5 minute integration could be supported by the ocean, and that our experience at 200 and 400 hertz had shown that a tow ship could maintain sufficient stability to admit such integration;

(2) something like 5 to 10 watts per frequency line had a chance of coming through the ocean and the FFT with a 9 dB output signal-to-noise ratio about half of the time;

(3) the signal should permit shorter FFT integration times if we were wrong about (1).

(The reader should know that the rms noise from an FFT bin has a 5.7 dB standard deviation in the absence of signal, and that each signal line will be subject to serious interference fading. In long range propagation snr prediction is a very probabilistic procedure.) Add to the conclusions so far: 50 watts into the carrier, and try for 5 to 10 watts in every other spectral line.

The signal is taking form: about 5 to 10 significant spectral lines together with the carrier line can be used for information extraction at long ranges. Primary processing will be a 2.5 minute FFT (rough time), but shorter FFT's must be feasible.

A long-standing philosophy (perhaps a prejudice) at CEL is that digital signal processing matches nicer to digitally modulated signals than to analog modulated signals. The specific decision for PANOIC77: digital phase modulation was selected and signals like swept-FM

were not considered. Digital modulation means that the signal is segmented in time into an integer number of equal duration segments, called "digits." The signal design consists of choosing the waveform for each digit, the digit duration, and the number of digits. Roughly speaking, the number of digits will be the number of significant lines in the power spectrum; for PANOIC77, 5 to 10. Next the digit waveforms: the desire is to drive the projector at full power; the projector is broadband as far as projectors go ($Q=3$ or 4), but since it is less than an octave wide, the simplest full swing peak-to-peak waveforms are sinewave-like. There are many variations on a sinewave; the CEL decision was that the digit waveforms would be pure sinewaves at some phases and at the same frequency.

Let's stop and review the reasons for modulating, i.e., for transmitting more than just the carrier. The signal processor views propagation measurement as a measurement of the time-varying complex transfer function of the ocean, $H(f,T)$. Measurement at 5 or 10 "f" values is much better than measurement at just one "f" value, if there is change across the "f" range. Next, the ability to time-resolve is inversely proportional to the bandwidth, and multiple lines are necessary to get bandwidth. Two more points of theory are helpful. The inherent time resolution of a signal is its autocorrelation function, the transform of its power spectrum; two signals with the same power spectrum have the same inherent time resolution capability.

Next, if resolution is viewed as, "What would a simple rectangular pulse do in this ocean?" Then the closer the power spectrum is to that of a rectangular pulse, the less snr the signal processor will have to give up to answer that question. We know that binary conjugate phase modulation of a carrier (discussed below) will yield signals that have pulse-like spectra, and with "factor inverse filtering" such signals can be corrected at low snr loss to yield rectangular pulse resolution answers.

A computer search was performed over all possible binary codes for conjugate phase modulation, for 2 through 22 digits, and the power spectra analyzed for average mainlines level and potential loss in snr resulting from variation from rectangular pulse power spectra. From the best and old favorite, the 7-digit linear maximal sequence (+---+---) was selected. Being a linear maximal, it has precisely the same power spectrum as a rectangular pulse, differing only in the spectral phases.

The remaining design parameter is the digit duration, or equivalently, the signal period, 7 times the digit duration. The signal bandwidth (nominal) is the reciprocal of the digit duration, and the nominal resolution is the digit duration; hence digit duration should be as small as possible. The signal spectral lines are spaced at the reciprocal of the signal duration, i.e., at one-seventh of the bandwidth. The lines should be far enough apart so

that the transfer function values, $H(f,T)$, are different, but close enough together that line-to-line interpolation has some justification. How close? If we knew that, we wouldn't have to conduct the experiment. The author has a crude rule of thumb: the mid-ocean multipath spread is 1 percent of the travel time. It's an Atlantic rule of thumb, and it has a lot of conditions to be scientific, but it establishes the general ballpark: 16.2 seconds for 2000 miles. Ray path calculations by Dr. Jobst of IAR indicate a smaller multipath spread (that is nicer). If the multipath spread is 10 seconds, signal lines 1/10 hertz apart might be on different "lobes" of a selective fading transfer function. That would mean the lines should be closer than 1/10 hertz. In the light of Jobst's calculations, and the crudeness of my own rule of thumb, 0.05 hertz was deemed to be close enough to permit interpolation, but far enough apart to show considerable change at long range. Just to be on the safe side, a secondary option of 0.10 hertz spacing was allowed in the modulator to cover twice the bandwidth if that appeared to be a better choice during the experiment.

This concludes the (perhaps devious, somewhat arbitrary) history of the design of the PANOIC77 signal. The next sections will present the technical material on binary conjugate phase modulated signals, the relationship between

the two versions of this signal used in PANOIC77, and the complex demodulation of the signals that matches neatly to FFT analysis. The final section will touch on extra features, such as off-sections of the transmission.

3. Periodic Conjugate Modulation

The full title of this section should be something like "periodic digital signals formed by binary conjugate modulation using linear maximal pseudorandom sequences (m-sequences) of seven digits." The treatment is mostly equations, and broken into four subsections:

periodic digital signals

binary conjugate modulation

linear maximal sequences

the seven-digit sequence

3.1 Periodic Digital Signals. Let

T = digit duration in seconds

L = number of digits per period

$1/LT$ = eigenfrequency spacing in hertz

$d(t;k)$ = waveform of the k th digit

centered at $t=kT$

active on $(k-0.5)T < t < (k+0.5)T$

$D(f;k)$ = Fourier transform of $d(t;k)$

$s(t)$ = the periodic signal

$$s(t) = \sum_{k=0}^{L-1} d(t;k) \quad -0.5T < t < (L-0.5)T$$

= $s(t-pT)$ for all other t , p is integer

The Fourier series of $s(t)$ at frequency $f=n/LT$ is

$$S(n) = \frac{1}{LT} \sum_{k=0}^{L-1} D(n/LT ; k)$$

These equations describe a periodic waveform, $s(t)$, composed of L digits of equal duration, and merely indicate that the signal spectrum is the sum of the digit transforms read at eigenfrequencies.

3.2 Binary Conjugate Modulation. A special form of digital signal uses one basic digit waveform.

Let $c(t)$ be active on $-0.5T < t < 0.5T$ (and 0 elsewhere)

$C(f)$ be the Fourier transform of $c(t)$

$m(0), m(1), \dots, m(L-1)$ be a sequence of +1's and -1's

Time direction modulation means

$$d(t;k) = c(kT+m(k)t)$$

That is, when $m(k) = 1$

$$d(t;k) = c(kT+t)$$

$$D(f;k) = C(+f) e^{-j2\pi f k T}$$

and when $m(k) = -1$

$$d(t;k) = c(kT-t)$$

$$D(f;k) = C(-f) e^{-j2\pi f k T}$$

so

$$D(n/LT;k) = C(m(k)n/LT) e^{-j2\pi n k / L}$$

and

$$S(n) = (1/LT) \sum_{k=0}^{L-1} C(m(k)n/LT) e^{-j2\pi nk/L}$$

When the basic waveform, $c(t)$, is real, the spectrum at negative frequencies is the complex conjugate of the spectrum at corresponding positive frequencies. Thus time direction modulation using real waveforms means each digit has a given spectrum, or the conjugate of that spectrum. This is the basis for the title "binary conjugate modulation." A simple special case of real-time direction modulation is digital phase modulation using

$$c(t) = 2 \cos(2 FT + A)$$

where F is the carrier frequency. We shall work with digit durations and carrier frequencies such that FT is an integer. This FT product is the number of carrier cycles per digit; it is sometimes called " Q "; in PANOIC77 $Q=128$ or $Q=256$. The Fourier transform of $c(t)$ is

$$C(f) = T \left[e^{jA} \text{sinc}(fT-Q) + e^{-jA} \text{sinc}(fT+Q) \right]$$

and

$$C(-f) = T \left[e^{-jA} \text{sinc}(fT-Q) + e^{jA} \text{sinc}(fT+Q) \right]$$

by the even symmetry of the sinc function. Therefore

$$S(n) = \text{sinc}((n/L)-Q) \frac{1}{L} \sum_{k=0}^{L-1} e^{jAm(k)} e^{-j2\pi nk/L} \\ + \text{sinc}((n/L)+Q) \frac{1}{L} \sum_{k=0}^{L-1} e^{-jAm(k)} e^{-j2\pi nk/L}$$

Let

$$M(n) = \frac{1}{L} \sum_{k=0}^{L-1} e^{jAm(k)} e^{-j2\pi nk/L}$$

For high Q signals (meaning $Q > 3$ or so) the effects of the two terms in the signal spectrum are effectively isolated; for positive frequencies the signal spectrum is essentially the first term.

$$S(n) = \text{sinc}((n/L) - Q) M(n) \quad n > 0$$

The Fourier series of the continuous signal, $S(n)$, depends on the DFT (Discrete Fourier Transform) of the modulating phasors. The sinc function reflects the carrier frequency, $F = Q/T$, and the number of modulating digits, L .

3.3 Linear Maximal Sequences. The purpose of this short subsection is to state the power spectrum of m -sequences. It is fairly well known that the bipolar (+1, -1) form of m -sequence has a so-called "perfect auto-correlation" and hence nearly flat spectrum. The auto-correlation is not strictly zero outside the peak, but is $-1/L$ (vs a peak of 1). Correspondingly, the power spectrum at zero frequency is $1/(L+1)$ of any other line. What is not so widely known is that the phasor form of the m -sequence has a similar departure from "perfect," but that the degree of "imperfection" is controlled by the phase angle, A . The power spectrum is

$$|M(0)|^2 = \cos^2(A) + \sin^2(A)/L^2$$

$$|M(n)|^2 = \sin^2(A) * (L+1)/L^2 \quad n=1,2,\dots,L-1$$

Since the spectrum $M(n)$ is a DFT, it is periodic in frequency index, with period L , $M(0)$ is relevant for all frequencies whose index is an integer multiple of L . All but one of these is irrelevant, because the "sinc" factor in $S(n)$ zeros at every multiple of L except at the carrier frequency where $n=LQ$. The practical interpretation of $M(0)$ is therefore $M(LQ)$, the value of the carrier line. The modulation angle A can be used to adjust the carrier proportion of the total signal power. The DFT power spectrum can be made exactly flat by choosing A to satisfy

$$\tan^2(A) = L$$

The m-sequence of phasors based on the above angle has a true "perfect autocorrelation function."

The fact that the signal phase modulated by a binary m-sequence has the same power spectrum as a rectangular pulse of one digit duration (except for the carrier power) means that this signal has the same time resolution properties as the simple pulse (if the carrier is correctly compensated).

3.4 The Seven-Digit Sequence. The sequence used in PANOIC77 is "+---+---", meaning

$$m(0) = +1$$

$$m(1) = m(2) = m(4) = -1$$

$$m(6) = m(5) = m(3) = +1$$

This particular choice of the time origin so that the -1 digits fall onto the digits whose index is an integer power of 2 yields a very simple phase structure for $M(n)$.

$$\begin{aligned} 7 M(n) &= j \sin(A) + 7 \cos(A) , & n=0 & \text{mod } 7 \\ &= (j - \sqrt{7}) \sin(A) , & n=1,2,4 & \text{mod } 7 \\ &= (j + \sqrt{7}) \sin(A) , & n=6,5,3 & \text{mod } 7 \end{aligned}$$

PANOIC77 uses a 45-degree modulation angle, so numerically

$$M(0) = 0.10102 j + 0.70711$$

$$M(1) = 0.10102 j - 0.26726$$

$$M(-1) = 0.10102 j + 0.26726$$

or in polar form

$$M(0) = 5/7 \text{ at } 8.1305 \text{ degrees}$$

$$M(1) = 2/7 \text{ at } 20.7058 \text{ degrees}$$

$$M(-1) = 2/7 \text{ at } 159.2942 \text{ degrees}$$

4. The Slow and Fast Sequence Pair

The seven-digit sequence is used to produce two similar signals. The "slow" signal uses $Q=256$, 256 carrier cycles per digit. The "fast" signal uses $Q=128$, and therefore has a period which is just one-half of the

period of the slow signal. From the spectrum viewpoint, the eigenfrequencies of the fast signal are spaced twice as far apart as are the frequencies of the slow signal. This is hidden when Fourier series spectra are used, so in this section the notation will be shifted to indicate real frequencies in hertz. Let

$$f = nF/LQ \quad \text{or} \quad n = LQf/F$$

The spectrum of the slow sequence signal is

$$S'(nF/1792) = \text{sinc} ((n-1792)/7) \quad M(n)$$

or

$$S'(f) = \text{sinc} (256/f-F)/F) \quad M(1792f/F)$$

Because the DFT $M(n)$ has period 7, an equivalent formula is

$$S'(f) = \text{sinc} (256(f-F)/F) \quad M(1792(f-F)/F)$$

The spectrum of the fast sequence signal is

$$S''(f) = \text{sinc} (128(f-F)/F) \quad M(896(f-F)/F)$$

Table 1 lists the spectral values about the carrier frequency.

The following special angles are used:

$$B = \text{arccot} (\sqrt{7}) = 20.7058 \text{ degrees}$$

$$B' = \text{supplement } B = 159.2942 \text{ degrees}$$

$$C = \text{arccot} (7) = 8.1305 \text{ degrees}$$

Table 1. Spectral line values

$1792(f-F)/F$	Slow , $S'(f)$	Fast, $S''(f)$
-14	0	0
-13	-0.07437 @ B	0
-12	-0.14517 @ B	0.16113 @ B
-11	-0.19748 @ B'	0
-10	-0.21723 @ B	0.34841 @ B
-9	-0.19356 @ B'	0
-8	-0.12085 @ B'	0.54308 @ B'
-7	0	0
-6	0.16113 @ B	0.72410 @ B
-5	0.34841 @ B	0
-4	0.54308 @ B'	0.87103 @ B'
-3	0.72410 @ B	0
-2	0.87103 @ B'	0.96677 @ B'
-1	0.96677 @ B'	0
0	2.5 @ C	2.5 @ C
1	0.96677 @ B	0
2	0.87103 @ B	0.96677 @ B
3	0.72410 @ B'	0
4	0.54308 @ B	0.87103 @ B
5	0.34841 @ B'	0
6	0.16113 @ B'	0.72410 @ B'
7	0	0
8	-0.12085 @ B	0.54308 @ B
9	-0.19356 @ B	0
10	-0.21723 @ B'	0.34841 @ B'
11	-0.19748 @ B	0
12	-0.14517 @ B'	0.16113 @ B'
13	-0.07437 @ B'	0
14	0	0

Table 1 seems to tell the story better than equations; the spectral phases read B B B' B B' B' as frequency increases, skipping every seventh term (that corresponds to $M(0)$). The B angles are in positions 1,2,4; the B' angles are in positions 3,5, and 6. The magnitudes in Table 1 are adjusted so the "sinc part" is unity at $f=F$; the 2.5 reflects the carrier increase caused by using 45-degree phase modulation.

Table 1 displays another important fact: the phase relationship between the two sequences. The spectral lines that the two signals have in common have the same phase across the main lobe of the slow sequence signal. When a signal change is made during a coherent spectral processing such as an FFT, the answers will be affected by the amplitude changes, but there will be no phase change effect. The spectral lines that suddenly appear or disappear will yield answers proportional to the proportion of time the respective signal is present during the analysis.

This pair of sequence signals was selected, and great care exercised in the controller and signal generator to align the "time $t=0$ " for the signals, just to obtain these spectral phase matches. The two signals have a normalized cross-correlation coefficient of exactly one-half if the entire spectrum is used.

5. Complex Demodulation Matched to an FFT

All of the spectral equations in the analyses so far are based on the period of the signal. The nice line structure, the precise phase relationships, the simple power spectrum, all depend on involving exactly an integer number of periods in computation. This is true of the signal processing of any periodic signal. In PANOIC77 there is a special problem: the signal contains 7 digits, and the FFT processing will use an integer-power-of-2 "samples"; 7 and 2^n are incommensurate.

The reader may have noted that the signal Q was selected to be either 128 or 256, 2^7 or 2^8 . That was most intentional; the processing must somehow eliminate one factor of 7 before the FFT and the incommensurate nature disappears.

There are several solutions. The ones discussed here deal with the complex demodulation that occurs after A/D conversion and before the FFT. The "front end" signal processing used in PANOIC77 is typical of many processing systems, and always used in CEL work; it is sketched in Fig. 1.

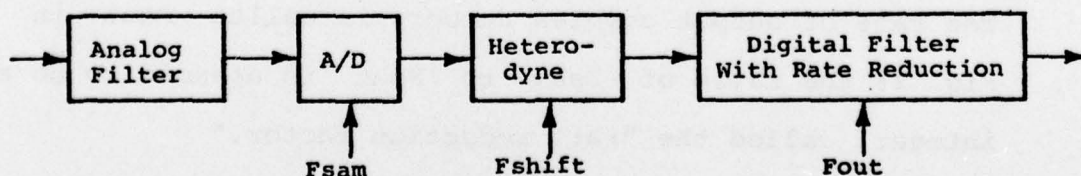

Figure 1. Front end block diagram

The analog filter is usually called the "anti-aliasing" filter because the subsequent sampling will treat signals differing by multiples of F_{sam} alike - they will be forevermore confused unless this analog filter eliminates all inputs except in a band less than F_{sam} wide. (Technical point: a baseband from $-W$ hertz to $+W$ hertz is $2W$ hertz wide.) A second important purpose of the analog filter is to reduce the noise power from frequencies that may later be eliminated, but which tax the dynamic range of the A/D converter if passed.

The input signal is real, and the A/D converter produces a stream of values; call them $4(k)$; the k th sample time is

$$t(k) = k/F_{sam}$$

Complex demodulation consists of heterodyning (frequency shifting, usually downshifting) followed by narrowband filtering (smoothing). When the original signal is a high-Q signal, the filtered stream of numbers is quite redundant, so the data rate may be reduced by retaining some uniformly-spaced subsequence of the filtered stream. Normally the only filter output values calculated are this subsequence. The rate of output complex numbers is called F_{out} in Fig. 1; the ratio of F_{sam} to F_{out} is assumed to be an integer, called the "rate reduction factor."

A favorite CEL technique is to use

$$F_{sam} = 4 F \qquad F_{shift} = -F$$

The sequence of numbers from the heterodyne operation are

$$r(k) e^{j2\pi(-F)(k/4F)} = r(k) (-j)^k$$

i.e., $r(0)$, $-jr(1)$, $-r(2)$, $jr(3)$, $r(4)$, $-jr(5)$, etc. This "4F" sampling method reduces the heterodyning from a complex multiplication to a simple sorting (into real and imaginary lists) and negation.

Another common practice at CEL is to accomplish the digital filtering in two stages. From each 4 real samples a single complex number is formed

$$z(n) = r(4n) - jr(4n+1) - r(4n+2) + jr(4n+3)$$

This has the practical consequence of causing zero response to any dc at the input, and to the inevitable dc-offset of the A/D converter. The rate of occurrence of these "one cycle demodulates" is F , and there will be 7Q of them per signal period. The rate reduction factor of the second stage of the digital filter must have a factor of 7, and all other factors must be 2, for there to be an integer power of 2 filtered outputs per signal period. PANOIC77 uses a second stage spanning 28 cycles of F , and an output rate of

$$F_{out} = F/14 = F_{sam}/56$$

The second stage filter impulse response is real, symmetric, and triangular.

A slightly different juggling of the complex demodulation was programmed by SDC (System Development Corporation) to accomplish the same objective: 14 F cycles per filtered output, and F heterodyned to 0. Let

$$F_{sam} = (32/7) F \quad F_{shift} = -F \quad F_{out} = F/14$$

In this way the output rate corresponds to 14 F cycles and 64 real samples. The heterodyning uses 32 different phasors, and care must be taken to insure that roundoff error in the complex multiplication does not allow much response at dc.

In summary, the reduction rate factor in the PANOIC77 complex demodulation was selected to yield $F_{out}=F/14$ so that there would be Q/2 complex demodulates per signal period, either 64 (slow signal) or 32 (fast signal). The subsequent FFT of 6 or more layers will span an integer number of transmitted signal periods.

A final comment on Doppler: all the above was based on the period of the received signal being equal to the period of the transmitted signal. The Doppler effect causes a time scaling by a factor of $(1 + v/c)$, where v is the velocity component of the projector toward the receiver in the horizontal plane (Flat earth approximation). The speed of sound, c, is roughly 2950 knots; the projector tow speed less than 1/250 of this. The Doppler factor is

between 0.996 and 1.004. Although this has a major effect on the frequency of the reception, it has only a minor effect on the eigenfrequency spacing over the major spectral lobe of the signal (13 lines).

6. Transmission Schedule

The PANOIC77 Controller and Signal Generator was designed to run virtually unattended, with all timing derived from counting the number of periods of the slow sequence signal, or equivalently, pairs of period of the fast sequence signal.

In "Standard" operation the equipment will transmit 640 slow sequence periods, and pause for 64 slow sequence periods. This is repeated.

In the "Mixed" operation the equipment will transmit 160 slow sequence periods, then 320 x 2 fast sequence periods, then 160 slow sequence periods, and pause for 64 slow sequence periods. This is repeated.

Each one of these on/off cycles is 3 to 4 hours long, depending on the carrier frequency. Off periods are provided to allow for tow cable adjustment.

PART II

The PANOIC77 Controller and Signal Generator

This report documents the design and operation of the PANOIC77 Controller and Signal Generator. This unit is the latest in a series of signal sources designed and constructed at the Cooley Electronics Laboratory (CEL) of The University of Michigan for use in underwater acoustic propagation studies. The equipment was designed specifically for the PANOIC77 experiment to be conducted during July through September 1977. It is both a dual signal generator, generating an unmodulated (CW) signal at one frequency and a modulated signal (SEQ) at a different carrier frequency, and a controller that can cycle through specific on/off patterns for these signals. The unit contains its own frequency and timing standard. Although it was designed to run unattended for long periods, it allows operator control and intervention, allows the introduction of externally generated signals, provides level adjustments and metering, and has time/control state indicators.

This report is divided into three chapters. The first provides a very brief description of the signal generator's output waveforms. The second discusses how to operate the signal generator, and the third provides information pertinent to understanding the hardware design of the unit.

This equipment was designed by Dr. Gary E. J. Bold (on leave from the University of Auckland, New Zealand) in conjunction with Mr. Kurt Metzger.

This report was written by Mr. Kim Winick and Professor Theodore G. Birdsall.

1. Output Waveforms

The PANOIC77 signal generator synthesizes two types of signals. The first is a pure tone, CW, given analytically by

$$A(cw) \cos(2 \text{ PI } f(cw) t) \quad (1)$$

The amplitude $A(cw)$ is continuously adjustable to any value between 0 and 5 V peak (3.5 V rms). The frequency, $f(cw)$, is settable to any frequency given by Eq. 2.

$$f = 8000/N, \quad 0 < N < 256 \quad (2)$$

The second type of waveform is a carrier phase-modulated by a periodic binary digital waveform, $m(t)$, where $m(t) = +1$ or -1 .

$$A(seq) \cos(2 \text{ PI } f(seq) t + m(t) \text{ pI}/4) \quad (3)$$

$A(seq)$ is adjustable to any value between 0 and 5 V peak (3.5 V rms). The frequency, $f(seq)$, of the carrier can be taken on any of the values given by Eq. 2. Figure 2 shows the two modulating waveforms used in the PANOIC77 signal generator. These digital waveforms are composed of seven digits

$$m(0)=1, m(1)=m(2)=-1, m(3)=1, m(4)=-1, m(5)=m(6)=1$$

The time origin, $t=0$, occurs exactly in the middle of a $m(0)$ digit; this sets up certain phase matches between the two signals. The only difference between the two digital waveforms is the duration of the digits. The signal generated by using the longer digits will be called the "slow sequence" signal. The signal generated by phase modulating the carrier using the shorter digits will be called the "fast sequence" signal.

A detailed description of the modulated signals, their properties, and their use in underwater acoustic propagation research is contained in the companion report, The PANOIC77 Sequence Signal (Part I).

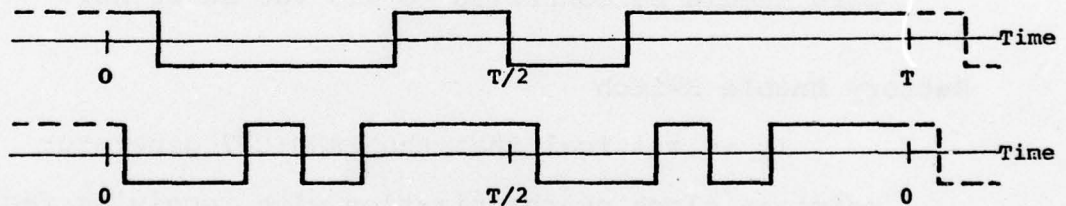

Figure 2. PANOIC77 Modulating waveforms
 (a) Slow sequence; period= $T=7*256/f(\text{seq})$ seconds
 (b) Fast sequence; period= $T/2=7*128/f(\text{seq})$ seconds

2. Operator's Controls and Frequency Setting

Most of the controls in the unit are available on the front panel described in Section 2.1. Should it be necessary to change acoustic transducers, and hence change the SEQ and CW frequencies, the operator will have to change two DIP headers inside the unit. This is described in Section 2.2.

2.1 Front Panel Controls on the PANOIC77 Signal Generator. Figure 3 is a diagram of the front panel of the PANOIC77 signal generator. A functional description of this panel is given below.

AC ON/OFF Switch

When in the ON position, the generator's power supply input is connected to the line cord. The line cord should be connected to 115 vac at 60 Hz.

Battery Enable Switch

It is critical that the PANOIC77 generator maintain clock synchronization with receiving facilities during momentary main power failures. Hence it is equipped with an auxiliary battery power supply to run the oscillator and counters if this happens. When the Battery Enable Switch is in the Enable position, this auxiliary supply will take over if the line voltage supplied to the signal generator falls below the level required to maintain the regulated 5 vdc to the logic chips. The auxiliary power supply

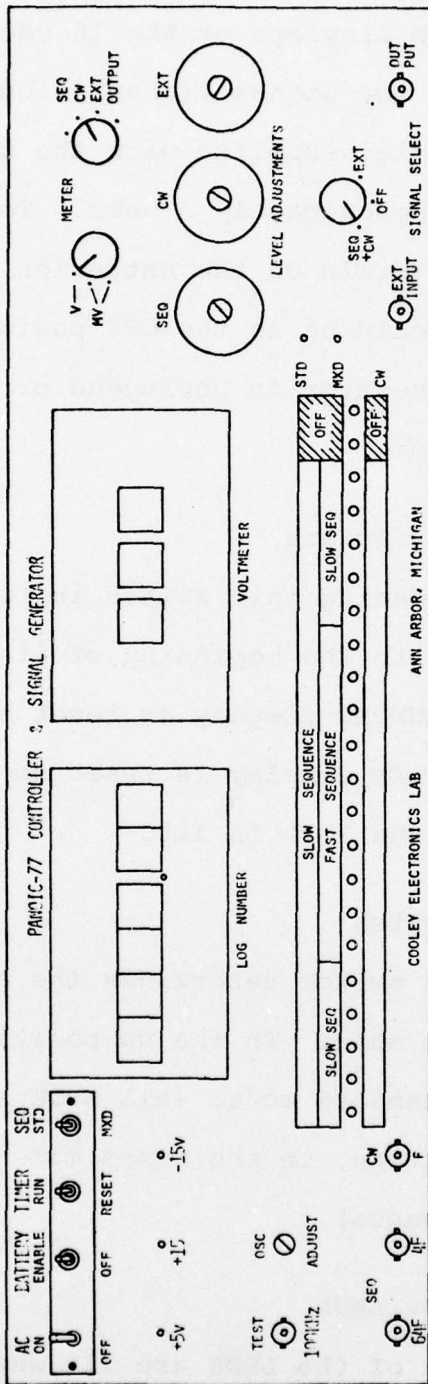

Figure 3. Front panel

COOLEY ELECTRONICS LAB ANN ARBOR, MICHIGAN

will supply power to the unit's logic chips thus maintaining timing, but it will not power the unit's 15 vdc LED displays or the 15 vdc OP-AMPS that are necessary for signal transmission to take place. The batteries supplied with the unit have a lifetime of approximately 1 hour. To avoid any unnecessary drain on the batteries, the Battery Enable Switch should be in the OFF position whenever the signal generator is unplugged or the AC OFF for more than 1 hour.

Timer RUN/RESET Switch

Depressing this switch initializes the signal generator to the beginning of its transmission cycle. The LOG NUMBER display is reset to all zeros, and the 22 light LED display is reset so that only the first light on the left is lit.

SEQ STD/MXD Switch

This switch determines the signal generator's operating mode. In the up position it will operate in the standard mode, (all SLOW sequence) and in the down position, in the mixed mode (both FAST and SLOW sequence).

+5v, +15v, -15v LEDS

Each of the LEDS are lit when the corresponding regulated dc power supplies are operating.

100 kHz TEST BNC

The signal generator has a master clock unit which should be set to 1024 kHz. The user may assume that the master clock frequency is precisely 10.24 times the frequency of the 100 kHz TEST BNC TTL-compatible square wave.

OSC Adjust (hole)

To the right of the 100 kHz TEST BNC is a hole in the front panel for access to a screwdriver adjustment on the crystal oven. This is used in conjunction with the output of the 100 kHz TEST signal to set the master clock to precisely 1024 kHz.

SEQ 64F0, 4F0, BNC's

The outputs labeled SEQ 64F0 and 4F0 are TTL-compatible square waves at frequencies of $64f(\text{seq})$ and $4f(\text{seq})$ respectively. $f(\text{seq})$ is the carrier frequency of the slow and fast sequence signals. 64F0 is the input frequency reference for the external BCSG-76 signal generator. 4F0 is the input sampling frequency for laboratory A/D computer testing.

CW F1 BNC

This output is a TTL-compatible square wave at the frequency of the CW signal. It is made available for frequency checking.

LOG NUMBER

The LOG NUMBER is an LED display of 4 decimal digits, a period, and then two more decimal digits. It advances by 0.01 every time either two fast or one slow sequence is synthesized. This is equivalent to advancing 0.01 for every 1792 cycles of modulated carrier, which will be called one period. One period after reaching $n.31$, the display will advance to $(n+1).00$. If $f(\text{seq}) = 88.8 \text{ Hz}$, the display advances by 0.01 every 20.16 seconds.

22 Light LED Display

These lights indicate which of the twenty-two transmission intervals is presently occurring. Each of these lights correspond to thirty-two periods. The single lit light will sequence from left to right and then start again. (The two lights to the right of this display indicate which of the two modes, standard or mixed, is currently selected.)

Signal Select Switch

The Signal Select Switch determines which of the three possible signals, CW plus sequence (i.e., either the slow or fast sequence) signal, the External Signal from the External Input Jack, or no signal at all appears at the Output BNC. The position of this switch does not influence the time operation as indicated by the LOG NUMBER and 22 lights.

Output BNC

This is the output of the signal generator, i.e., either the fast or slow sequence signal plus the CW signal, the EXTERNAL signal, or no signal at all. Which one of these appears at the output BNC depends upon the position of the Signal Selector Switch.

EXT INPUT BNC

Any external signal connected to this BNC will appear, times some gain factor, at the OUTPUT BNC when the SIGNAL SELECT SWITCH is in the EXT position.

Level Adjustments

These three screw driver adjustments allow the user to independently adjust the amplitude of the SEQ signal (i.e., either the slow or fast sequence), the CW signal, and the EXTERNAL signal (i.e., the signal from the EXT INPUT) to any value between 0 and 3.5 V rms. Full scale is ten complete revolutions.

Voltmeter Display

This meter displays the rms value of one of the following signals (as they would appear at the OUTPUT JACK were the SIGNAL SELECT SWITCH in the appropriate position): the SEQ signal (i.e., either the slow or fast sequence), the CW signal, the EXTERNAL signal, or the signal at the OUTPUT JACK. The signal being

read is selected by the rotary switch in the upper right-hand corner of the signal generator's front panel. This meter has three ranges 0.00 to 9.99 V rms, 000. to 999. mv rms, and 00.0 to 99.9 mv rms, selected by the rotary switch directly to the right of the voltmeter.

2.2 Setting the Frequencies in the PANOIC77 Signal Generator. Three transducers might be used during PANOIC77, and the signal frequencies have been selected to match these transducers' characteristics. Each transmission frequency is controlled by a divide chain from the internal 1024 kHz crystal oscillator. The variable divisors in these division chains are controlled by headers in sockets A-27 (for $f(\text{seq})$ the sequence carrier frequency) and A-26 (for $f(\text{cw})$, the CW frequency) of the 90 IC Augat board inside the equipment. These locations are indicated in Fig. 4. The resulting carrier and CW frequencies are related to the number, N , written on the header in binary form, by

$$f = 8000/N$$

In general N may be any integer between 1 and 255. For PANOIC77 the three transducers and their associated frequencies and divisors are as given in Table 2. Associated with each of the eight pairs of socket holes (1,16; 2,15; 3,14; 4,13; 5,12; 6,11; 7,10; 8,9) is a binary

33
GROUP A

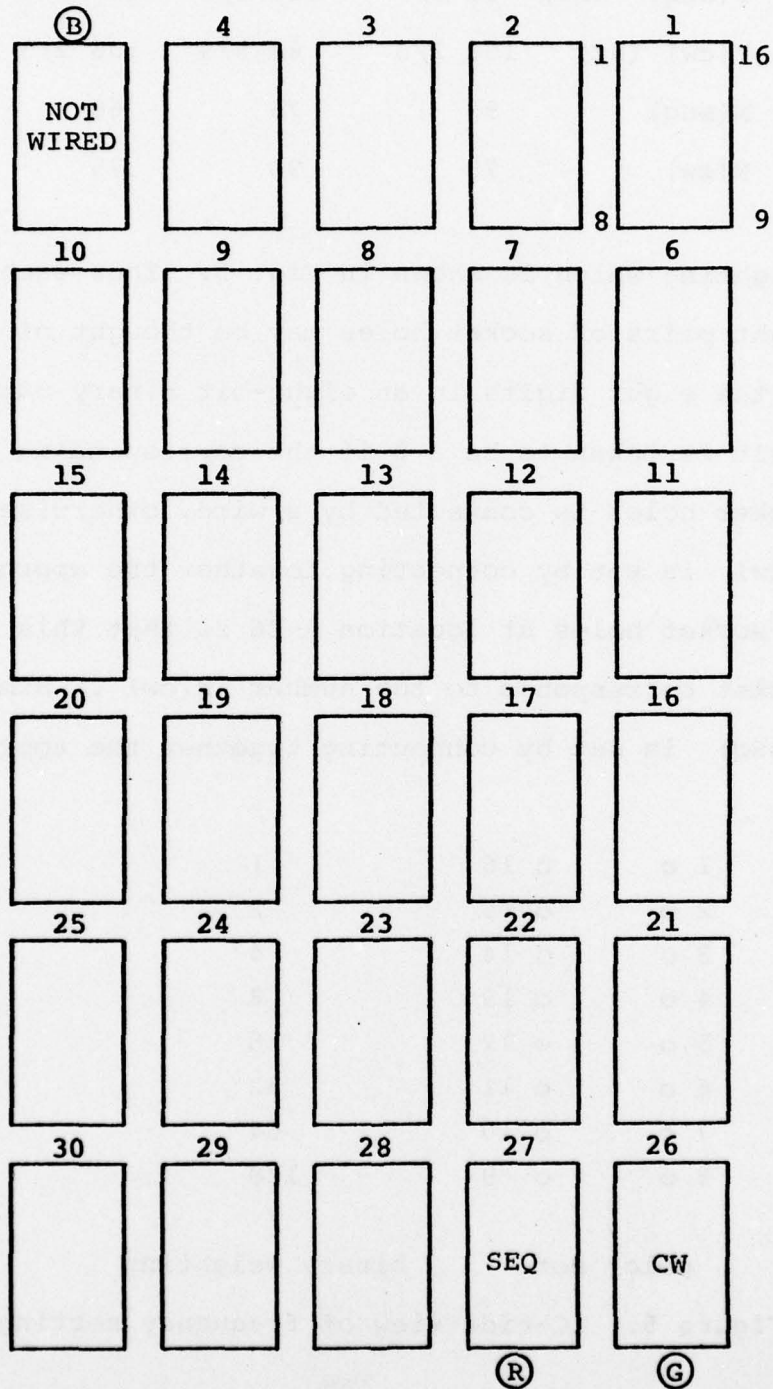
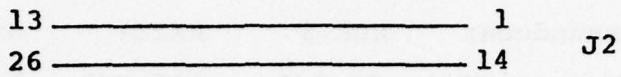
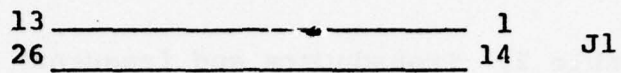

Figure 4. Header locations

Table 2. Transducers and frequency settings

Transducer	HLF 3	HX231	HX137
f(seq) (Hz)	88 8/9	106 2/3	133 1/3
F(cw) (Hz)	106 2/3	88 8/9	106 2/3
N(seq)	90	75	60
N(cw)	75	90	75

weighting which is shown in Fig. 5. Thus each of the eight pairs of socket holes may be thought of as one of the eight digits in an eight-bit binary number. The digit is taken to be a 0 if the corresponding pair of socket holes is connected by a wire, otherwise it is a 1. N(cw) is set by connecting together the appropriate pairs of socket holes at location A-26 so that this "wired up" socket corresponds to the number N(cw). Similarly N(seq) is set by connecting together the appropriate pairs

1 o	o 16	1
2 o	o 15	2
3 o	o 14	4
4 o	o 13	8
5 o	o 12	16
6 o	o 11	32
7 o	o 10	64
8 o	o 9	128
	0	/
	/	
color dot		binary weighting

Figure 5. IC-side view of frequency setting socket

of socket holes at location A-27 so that this "wired up" socket corresponds to the number $N(\text{seq})$. The actual connections are made by placing headers in the sockets at locations A-26 and A-27. Table 3 lists the three headers which will be required for PANOIC77. The PANOIC77 headers supplied with the unit are wired and color coded as shown in Fig. 6.

Table 3. Frequency setting header parameters

f (Hz)	88 8/9	106 2/3	133 1/3
N	90	75	60
color dot	red	green	blue

To operate the PANOIC77 signal generator with $f(\text{seq}) = 88 \frac{8}{9}$ Hz and $f(\text{cw}) = 106 \frac{2}{3}$ Hz, the green header should be in location A-26 and the red header in

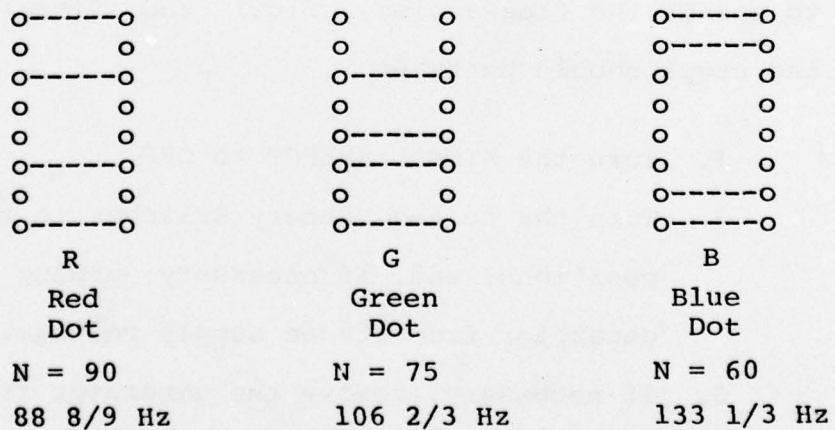

Figure 6. Divisor headers

location A-27. To operate the signal generator with $f(\text{seq}) = 106 \frac{2}{3} \text{ Hz}$ and $f(\text{cw}) = 88 \frac{8}{9} \text{ Hz}$, the red header should be in location A-26 and the green header in location A-27. Finally, to operate the signal generator with $f(\text{seq}) = 133 \frac{1}{3} \text{ Hz}$ and $f(\text{cw}) = 106 \frac{2}{3} \text{ Hz}$, the green header should be in location A-26 and the blue header in location A-27. Location A-5 on the 90 IC Augat board (see Fig. 4) is not wired to anything, and is used for storing the unused header. The three locations, A-5, A-26, and A-27 on the Augat board are also color coded as indicated in Fig. 4. The diagrams in Figs. 7, 8, and 9 correspond to the appropriate header placement for the three PANOIC77 transducers. The PANOIC77 signal generator when received will have the headers in the locations indicated in Fig. 7. This corresponds to $f(\text{seq}) = 88 \frac{8}{9} \text{ Hz}$ and $f(\text{cw}) = 106 \frac{2}{3} \text{ Hz}$.

If at any time during PANOIC77 it becomes necessary to change the frequencies, $f(\text{cw})$ and $f(\text{seq})$, the following steps should be taken.

1. Turn the SIGNAL SELECT to OFF.
2. Turn the ac and Battery Switches to their off positions, and, if necessary, unplug the signal generator from its ac supply voltage.
3. If necessary, remove the generator from the rack.

GROUP A

13 _____ 1
26 _____ 14 J1

13 _____ 1
26 _____ 14 J2

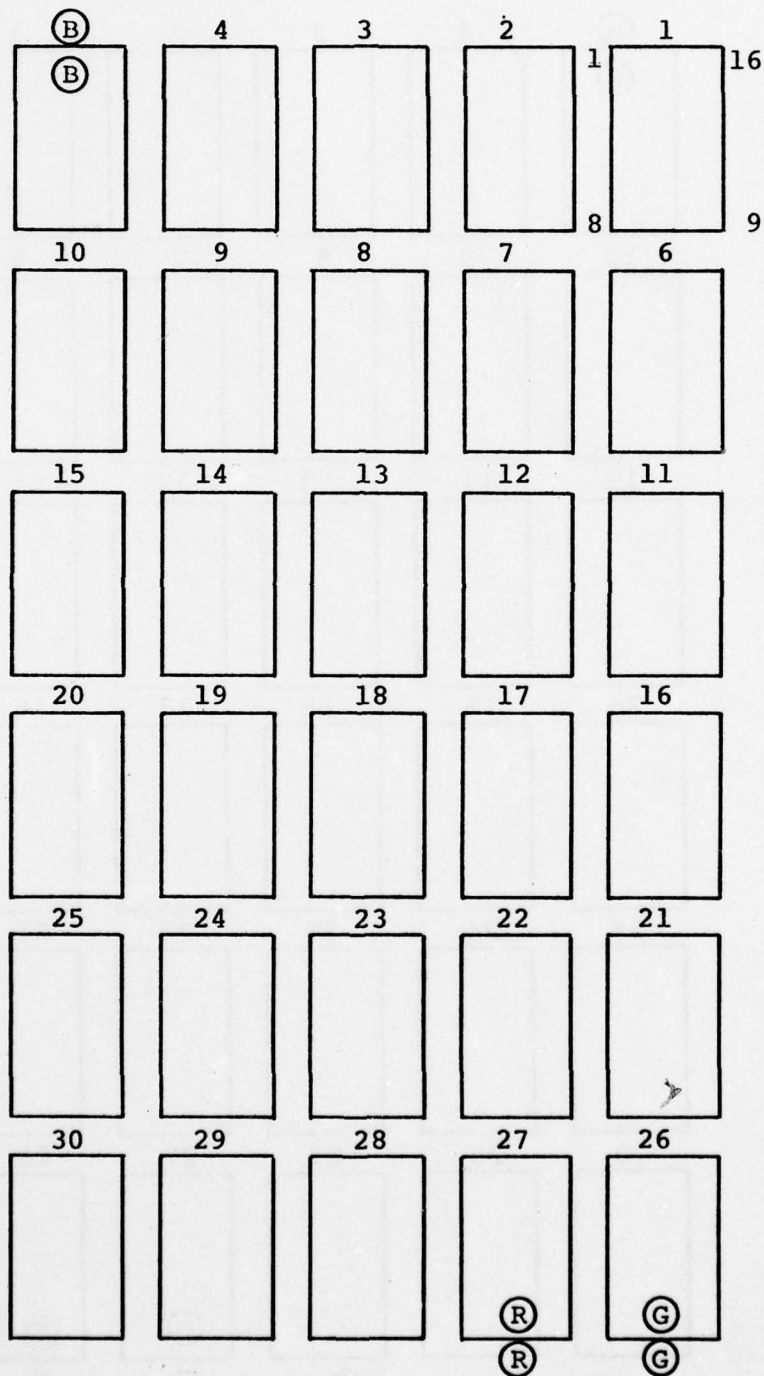

Figure 7. HLF 3 Headers

GROUP A

13 _____ 1
26 _____ 14 J1

13 _____ 1
26 _____ 14 J2

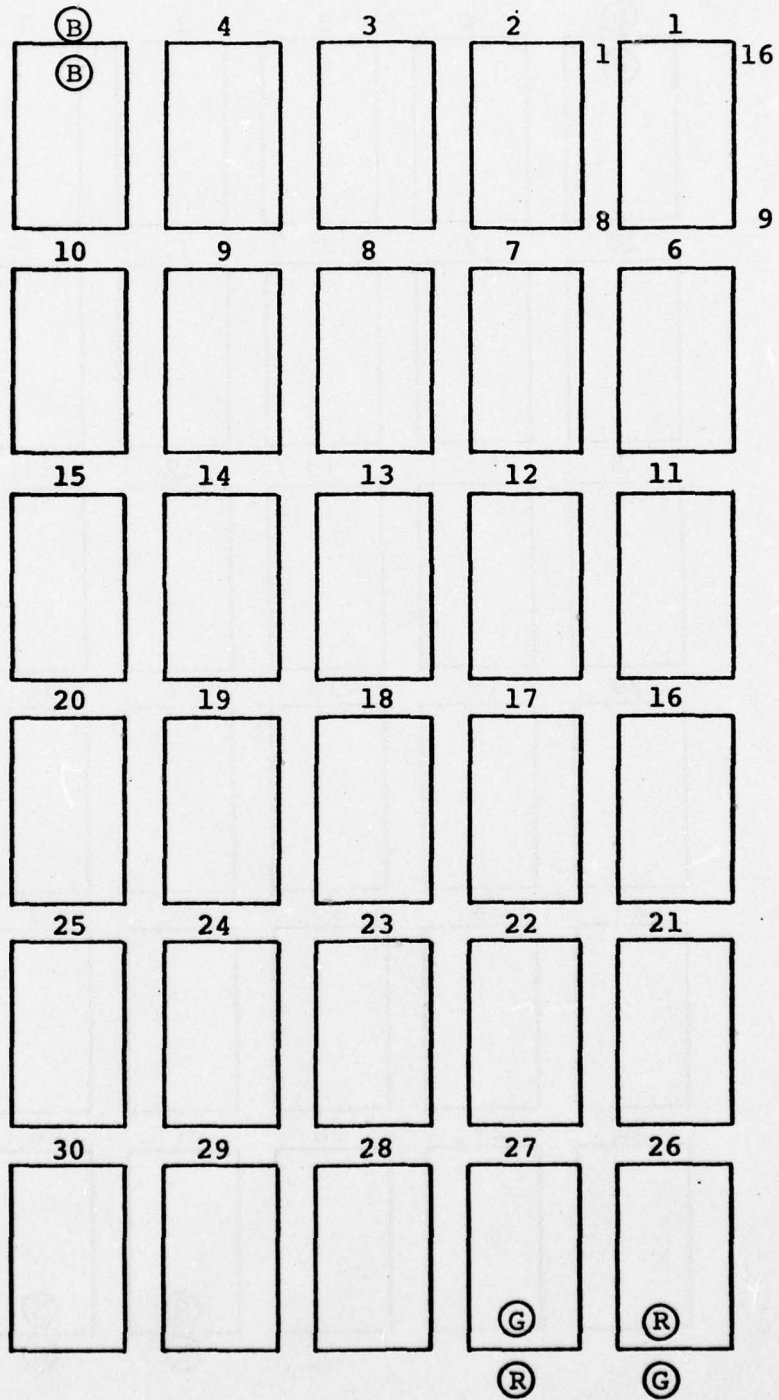

Figure 8. HX231 Headers

39
GROUP A

13 _____ 1
26 _____ 14 J1

13 _____ 1
26 _____ 14 J2

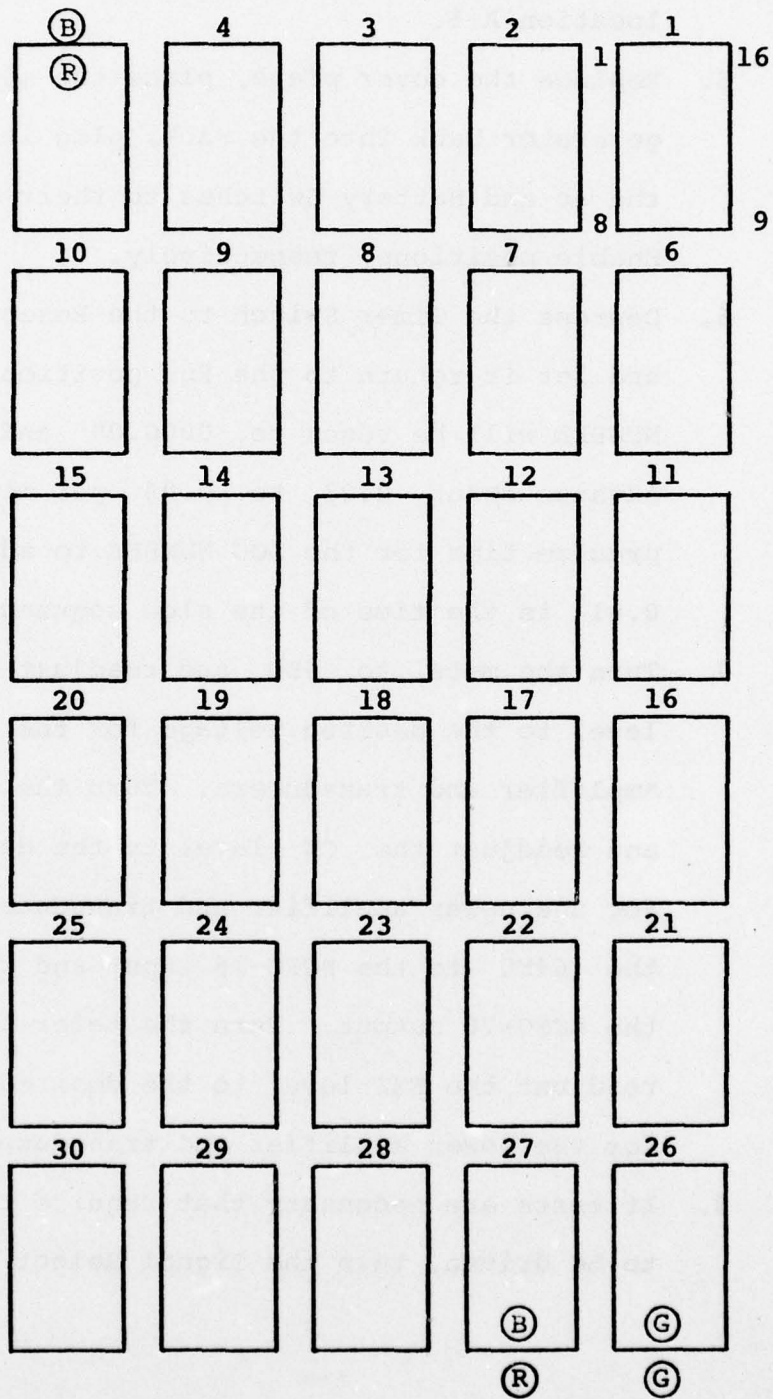

Figure 9. HX137 Headers

4. Remove the signal generator's top cover plate and put the appropriate headers in locations A-26 and A-27. The unused header should go in location A-5.
5. Replace the cover plate, place the signal generator back into the rack, plug it in, return the ac and Battery Switches to their On and Enable positions, respectively.
6. Depress the Timer Switch to the Reset position and let it return to the Run position. The LOG NUMBER will be reset to 0000.00 and begin to advance about 0.03 to 0.04 per minute. The precise time for the LOG NUMBER to advance by 0.01 is the time of one slow sequence.
7. Turn the meter to SEQ and readjust the SEQ level to the desired voltage for the power amplifier and transducers. Turn the meter to CW and readjust the CW level to the desired voltage for the power amplifier and transducer. Connect the 64F0 to the BCSG-76 input and the EXT IN to the BCSG-76 output. Turn the meter to EXT and readjust the EXT level to the desired voltage for the power amplifier and transducer.
8. If tests are necessary that require the transducer to be driven, turn the Signal Select Switch to

SEQ+CW or EXT , and the meter to OUT . When these tests and possible changes are completed, turn the Signal Select Switch to OFF . Meter and record the SEQ , CW ; and EXT voltages.

9. When everything is in readiness, consult the transmission schedule for the appropriate transducer (listed by $f(\text{seq})$ and $f(\text{cw})$). Find the next upcoming transmission time listed by date, hour, minute, second (Z-time = GMT). When that time approaches, depress the Time Switch, and release it at the indicated time.
10. Turn the Signal Select to SEQ+CW position. Record the time and log number as listed in the transmission schedule, and any estimate of time discrepancy in releasing the timer reset. The automatic transmissions should now follow the transmission schedule, except the displayed log number is low by the amount just recorded.

3. Hardware Design

The PANOIC77 Controller and Signal Generator is primarily a digital device that produces a controlled composite analog signal to be amplified and used to drive an acoustic transducer, and that provides information to the user as to the state of the generator, as well as controls of amplitudes, frequencies and generator state.

There are three types of design features that should be noted: although they are common features of the previous two CEL signal generators, the BCSG-74 and BCSG-76's, they may be novel features to the reader. These are (1) the use of a single master oscillator for deriving all frequencies and timing, (2) the use of ROM's (Read Only Memories) for storing sinewaves, storing the binary modulating sequences, storing the control signals, and for decoding the control state to display to the operator, and (3) the use of TAD modulation (Time Address Direction modulation) to accomplish binary phase modulation.

This chapter is divided into five major sections.

- (1) Master oscillator and reference frequency circuits
- (2) CW signal generation
- (3) SEQ modulations and signal generation
- (4) Timing/control states and state display
- (5) Amplitude adjustment and metering

3.1 Master Oscillator and Reference Frequency Circuits.

The master oscillator is a crystal oscillator in a controlled oven, set for 1024 kHz, and stable to 1 part in 100 million per day. The precise frequency may be adjusted by adjusting the oven temperature setting using a screw adjustment on the top of the oscillator/oven assembly. Figure 10 shows the three circuits that use the master oscillator output signal.

The first set of circuits in Fig. 10 provide a 100 kHz square wave for convenient checking of the oscillator frequency. The circuit contains a voltage controlled oscillator with a nominal frequency of 100 kHz, and this is the signal available at the "TEST 100 kHz" output BNC connector. This is divided by 50 to produce a symmetric square wave with nominal frequency of 2 kHz. The master oscillator signal is divided by 512 to produce a symmetric square wave with nominal frequency of 2 kHz. Inside the PLL chip these two square waves are compared, and the error signal is lowpass filtered to obtain the control voltage for the voltage controlled oscillator. In phase-locked condition the relative frequency error of the "TEST 100 kHz" signal is equal to the relative frequency error of the master oscillator.

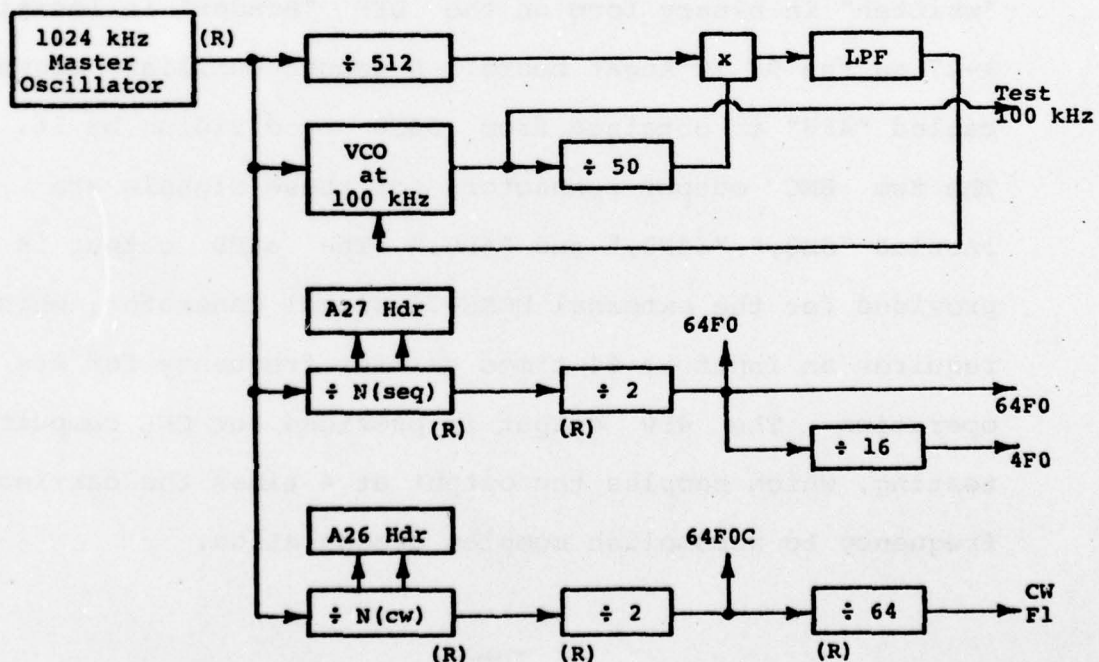

Figure 10. Master oscillator and reference frequencies

This circuit will be used at CEL to check the frequency setting against WWVB , and may be used by the operator for assurance that the master oscillator is still in adjustment. The designers feel that no adjustments will need to be made during the PANOIC77 experiment, but the 100 kHz signal will be helpful if adjustment is necessary.

The carrier frequency for the sequence modulated signal and the associated reference signals are determined by the second set of circuits shown in Fig. 10. Subsequent circuits require a signal at 64 times the carrier frequency; this is called the "64F0" signal. The 64F0 signal is obtained in two stages, by dividing the 1024 kHz signal by $N(\text{seq})$, and then one final division by 2 to obtain a symmetric square wave. The number $N(\text{seq})$ is "written" in binary form on the DIP "header" in location A-27 on the 90 IC Augat board. A second auxiliary signal called "4F0" is obtained from 64F0 by dividing by 16. The two BNC output connectors for these signals are labeled "SEQ," "64F0," and "4F0." The 64F0 output is provided for the external BCSG-76 signal generator, which requires an input at 64 times carrier frequency for its operation. The 4F0 output is provided for CEL computer testing, which samples the output at 4 times the carrier frequency to accomplish complex demodulation.

The frequency of the pure tone CW signal is determined by the third set of circuits shown in Fig. 10. Subsequent circuits require a signal at 64 times the CW frequency, this signal is called "64F0C" in the circuit diagrams. The 64F0C signal is derived from the 1024 kHz master oscillator signal by dividing in two stages, first dividing by $N(\text{cw})$, and then by 2 to obtain a symmetric square wave. For the users convenience, the 64F0C signal is further frequency divided by 64 so that it is at the actual CW frequency, and made available to the operator on the front panel BNC connector labeled "CW Fl." $N(\text{cw})$ is "written" in binary form on the DIP header in location A-26 on the 90 IC Augat board.

These 4 output signals (at the BNC connectors) are TTL compatible signals (+5 V, 0 V).

The "TIMER RESET" front panel switch affects these circuits. When that switch is depressed, it disconnects the 1024 kHz signal from the rest of the circuits and causes the counters that determine the SEQ and CW frequencies to be reset to 0. This is indicated by the (R) in Fig. 10. Certain subsequent counters that will be described later will also be zeroed.

3.2 CW Signal Generation. The CW signal generator circuit employs a 64 address ROM (read only memory) consisting of two 8 x 32 memory chips. The block diagram is Fig. 11. The 64F0C signal drives a six-stage binary

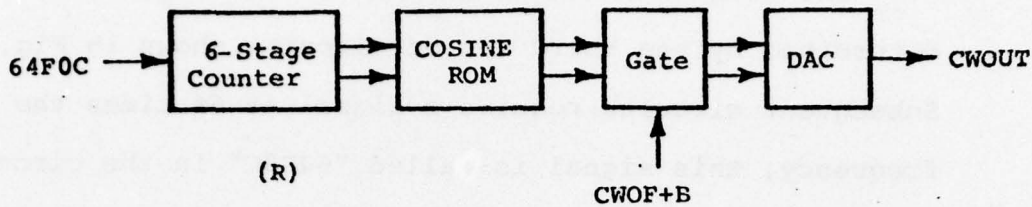

Figure 11. CW generator

counter. The counter state (ranging from 0 through 63 decimal) determines the address for the ROM. The contents of the ROM are the values of a cosine wave, quantized to 8 bits in amplitude and at 64 discrete angles spaced uniformly about a circle. This is referred to as a "cosine" ROM because the formula for the contents at address A is

$$C(A) = \text{int}(127 * \cos(2 \text{ PI } A/64) + 0.5)$$

where "int" means the integer just less than or equal to. The formula indicates that the values are rounded to the nearest integer, and that the range of values is from -127 at address 32 (180 degrees) to +127 at address 0 (0 degrees).

In order to turn the CW signal off a simple gate is placed between the ROM output and the DAC (digital to analog converter). The gate consists of 8 inverters each wired-OR'd to one of the ROM outputs, and controlled by the logic signal "CWOFF+B." When CWOFF+B is a logical one, the ROM output levels are clamped, and this

effectively disconnects the ROM from the DAC . There are some minor hardware comments: the DAC is unipolar, and the ROM memory is set for twos-complement values, so the high bit of the ROM output is inverted before going to the DAC ; the DAC itself is a DAC current-output chip, followed by an op-amp. The CWOUT is an analog voltage, but quite "staircase" in appearance; this will eventually disappear when the total signal is filtered just before the output.

3.3 SEQ Modulation and Signal Generation. The modulated signal is quite narrow band, and looks very much like a CW signal. Part of the sequence modulated signal generator, shown in Fig. 12, is much like the CW generator of Fig. 11. The 64F0 signal drives a six-stage binary counter, which in turn addresses a 64-address cosine ROM . The ROM output drives a DAC , and is decoupled from the DAC when the "SQOG+B" logic signal is a logical one. The essential difference is that the six-stage counter is an up/down counter, so it can be controlled to sequence through the cosine in the forward direction (+ direction) or through the cosine in the backwards direction (- direction). This is the essence of TAD , Time Address Direction modulation. In the PANOIC77 equipment the direction of addressing is controlled in segments of 64 carrier cycles each, and direction will change only

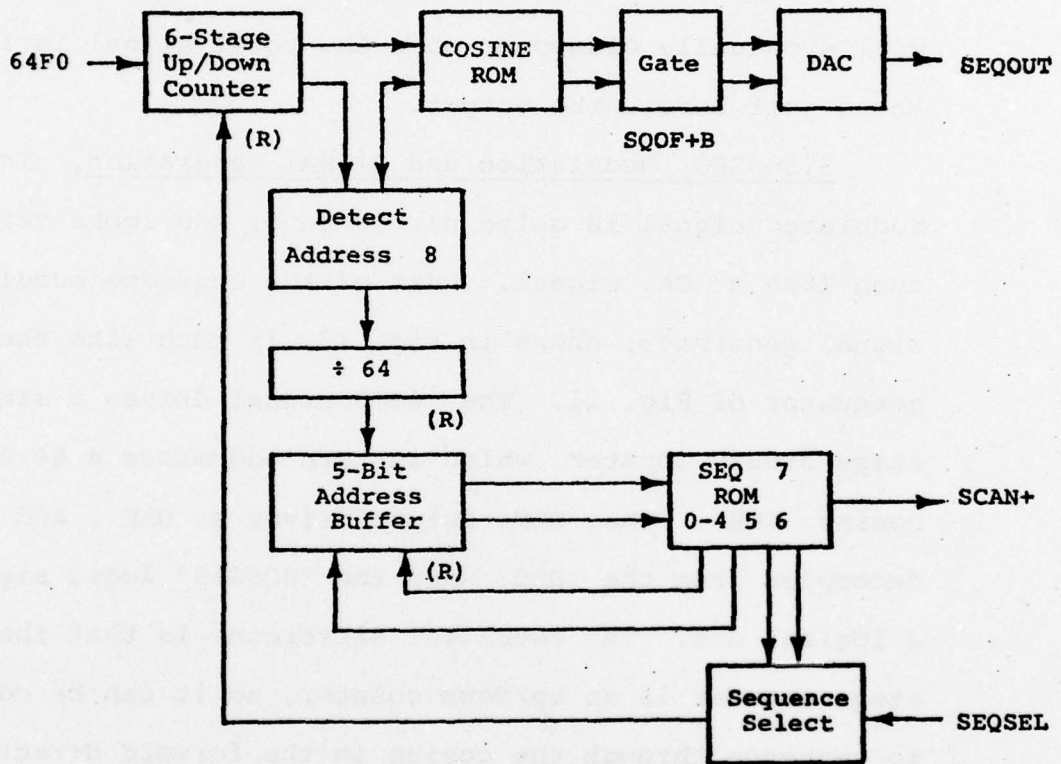

Figure 12. SEQ-Modulated signal generator

when ROM address 8 (45 degrees) is effective. If the positive direction is used, the SEQOUT signal is the "staircase" version of

$$\cos (\text{PI}/4 + 2 \text{ PI } F_0 t) = \cos (2 \text{ PI } F_0 t + \text{PI}/4)$$

and when the negative direction is used, the output corresponds to

$$\cos (\text{PI}/4 - 2 \text{ PI } F_0 t) = \cos (2 \text{ PI } F_0 t - \text{PI}/4)$$

The effect is to produce a digital binary phase shift modulated signal with phases of +45 degrees and -45 degrees. This has been called "complementary phase modulation" because the two signals are 90 degrees different. It is also referred to as "binary conjugate modulation" because the phasor forms of the two possible signals are always complex conjugates.

The up/down control is derived from one of two binary sequences stored in the "SEQ ROM," one sequence in bit 5 and the other in bit 6. Physically this ROM is one 8 x 32 chip. Only 28 of the addresses are used. To simplify the cycling, bits 0-4 of the SEQ ROM specify the "next address"; address 0 specifies 1 as the next address, address 1 specifies 2 as the next address, and so forth through address 26. Addresses 27 through 31 specify address 0 as the next address; this reduces circuitry, is robust, and automatically starts the sequencing at address 0 if the random turn-on state is outside the intended 28 addresses.

The 5-bit address buffer effects smooth stepping by holding the "new address" during transitions.

The sequences are stored using 28 values so that they are aligned at the middle of $m(o)$; the zeroth modulation digit. The 28-bit streams are

bit 5: 110000000011111000011111111111

bit 6: 100001100111111100001100111111

The Sequence Select circuit is a simple logic gate that selects either bit 5, the SLOW sequence, or bit 6, the FAST sequence, and is controlled by the logic signal "SEQSEL." The front panel switch "SEQ:STD/MXD" will clamp this logic signal to cause selection of the slow sequence when in the STD (Standard) position.

Bit 7 of the SEQ ROM is a zero except at address 0, where it is a one; the bit 7 output is called SCAN+ , and is used in subsequent circuits to count the number of periods (cycles of the SEQ ROM).

3.4 Timing/Control States and State Display. The state timing is all derived from counting the number of periods of the SEQ ROM , using the pulses on line SCAN+ . The unit state time increment for PANOIC77 is 32 periods and is called a "LITE"; that is, one LITE is the time required for 32 periods of the SEQ ROM . A LITE is 10.752 minutes when $f(\text{seq})$ is 88.888...hertz. In Fig. 13 the first circuit is a five-stage binary counter to count out these 32 periods. The state of this counter is

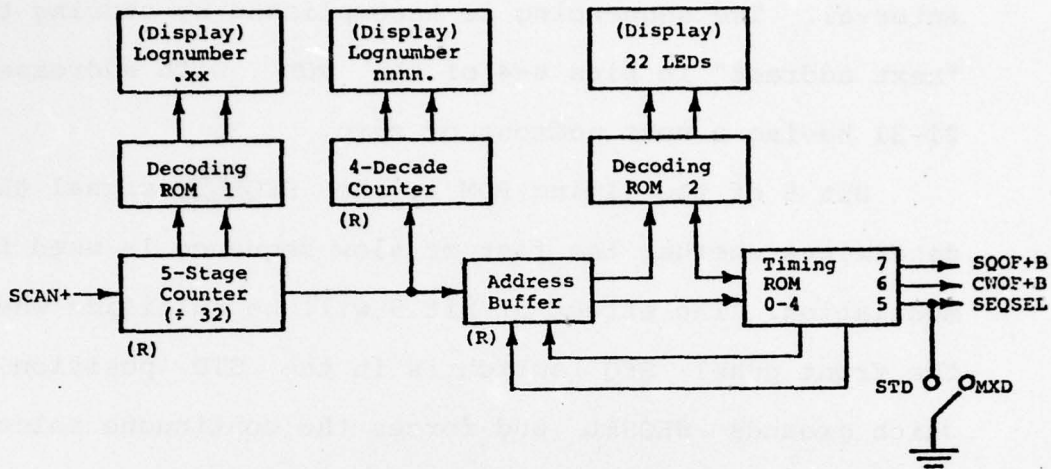

Figure 13. Control state circuits with displays

displayed as that part of the "Log Number" to the right of the decimal point. This causes the fractional part of the Log Number to count from 00 through 31. The binary to decimal conversion is accomplished in a single 8 x 32 ROM chip.

The integer part of the Log Number is a count of the number of LITEs that have been completed since the last RESET. This is accumulated in a four decade decimal counter, and displayed to the left of the decimal point of the Log Number.

A PANOIC77 Transmission interval consists of 22 LITEs. The Timing ROM, a single 8 x 32 ROM chip, is used to sequence through the LITEs and produce the necessary

control signals for each LITE state in the Transmission interval. The sequencing is accomplished by storing the "next address" in bits 0-4 of the ROM, with addresses 21-31 having a next address of zero.

Bit 5 of the Timing ROM is the SEQSEL signal that determines whether the fast or slow sequence is used for modulation. The effect of bit 5 will be nullified when the front panel SEQ switch is in the STD position, which grounds SEQSEL and forces the continuous selection of the slow sequence. When the front panel SEQ switch is in the MXD position, bit 5 of the Timing ROM actually controls SEQSEL. Currently the bit 5 coding is set for 5 LITEs slow sequence, 10 LITEs fast sequence, 5 LITEs slow sequence, and the final 2 LITEs are also slow sequence.

Bits 6 and 7 of the Timing ROM control CWOF+B and SQOF+B respectively, the signals that gate the CW and SEQ to their DACs. A logical one in bits 6 or 7 will decouple the generator from the output, effectively turning it off. (No generator is really ever turned off, because the timing is derived from the SEQ generator, and because the signal processing upon reception will depend heavily on phase coherence.) Currently bits 6 and 7 are set for 20 LITEs on (20 zeros) and 2 LITEs off (2 ones). Different schedules could be set up by simply changing the ROM contents.

To make it easy for an operator to determine what is being transmitted, or how long it will be before the next OFF period (last two LITEs), a row of 22 LED lights is on the front panel. At any one time one and only one of these lights will be lit, and the front panel is labeled above and below the lights with the meaning of the lit LED light. These lights are controlled by a decoding ROM , which decodes the current address of the Timing ROM . Three ROM chips are used for this decoding; they are mounted on the 22-light printed circuit board.

3.5 Amplitude Adjustment and Metering. The block diagram of the amplitude adjustment and metering circuit is shown in Fig. 14. The three inputs are SEQOUT and CWOUT from these signal's respective DACs , and the signal from the EXT INPUT connector (presumed to be the BCSG-76). Each is connected to a ten-turn 5000 ohm potentiometer which can be adjusted on the front panel. The adjusted SEQ and CW signals are added in a summing op-amp, the adjusted EXT signal passes through a similar unity gain op-amp. The SIGNAL SELECT rotary switch picks off the SEQ+CW sum, ground ("OFF"), or the adjusted and buffered EXT signal. The selected signal is filtered through an active two-pole Butterworth filter with 3 dB bandwidth of 388 hertz. The low frequency gain from potentiometer arm to output BNC is unity. The output impedance is low, being the output of an op-amp.

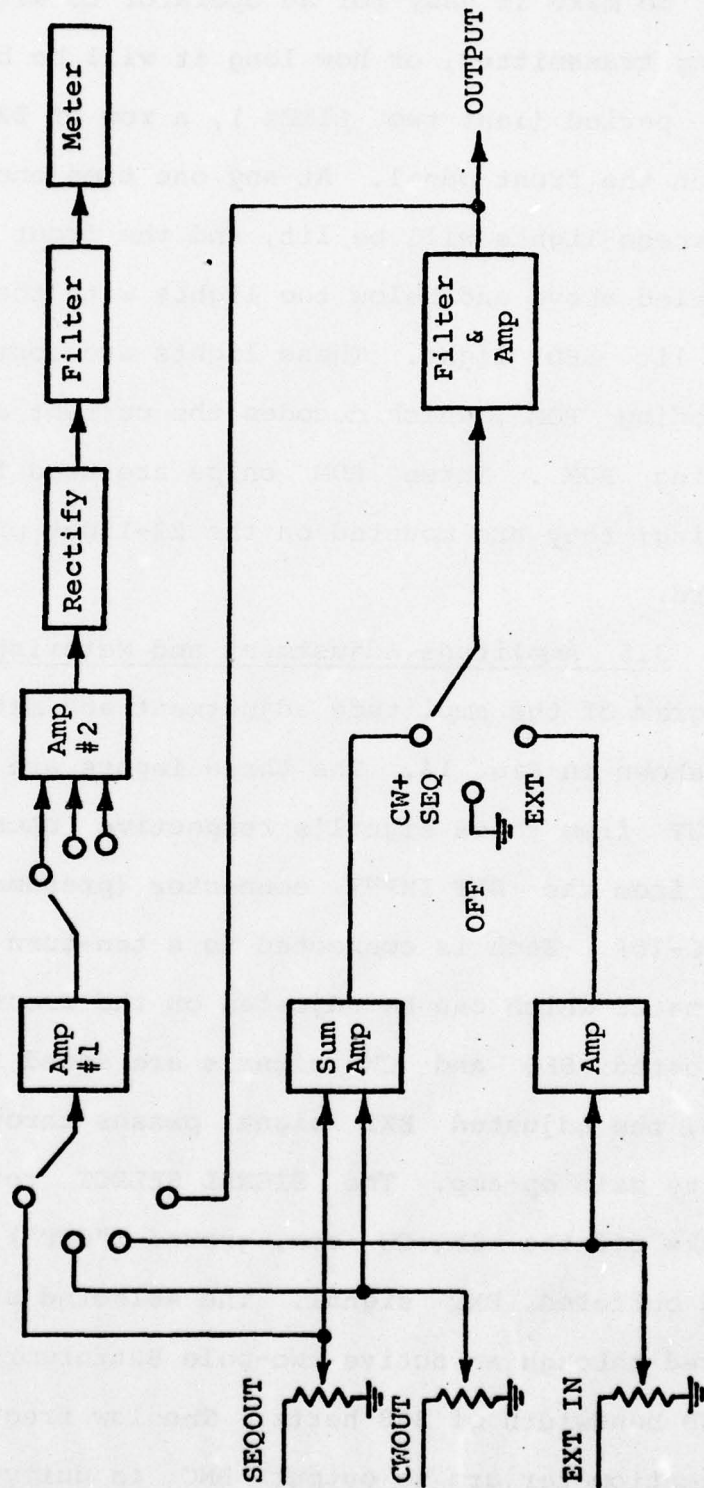

Figure 14. Level adjustment and metering circuits

The three potentiometer arm signals and the output signal are available to the first op-amp of the metering circuit. At the output of this amplifier the user may select one of three gains for the second op-amp. This is the meter range selection, and the position of the rotary switch sets the meter decimal point as well as the gain of the second op-amp. The range marked "V" has a maximum meter reading of 9.99 (volts), and the two ranges marked "mV" have maximum meter readings of 0.999 (millivolts) and 99.9 (millivolts). The output of the second op-amp is half-wave rectified in an active circuit, filtered by an active two pole Butterworth filter with 3 dB bandwidth of 1.8 hertz, and a dc offset correction added; this signal is then sent to the panel meter. The digital panel meter contains its own smoothing, A/D conversion and decoding. The overall gain and dc offset will be adjusted at CEL, and the designer feels that no further adjustment will be necessary. However, the dc offset may be observed by setting the SIGNAL SELECT to OFF and the meter to OUT .

The gain adjustment of the metering circuit has been set so that the meter displays the rms value of the input when that input is a sinewave in the frequency band of roughly 10 hertz to 200 hertz. The SEQ signal is quite narrowband, roughly one-half to one hertz wide at 88 to 133 hertz; the meter will dip slightly at the phase transition points of modulation. The EXT signal from the

BCSG-76 generator is expected to have a bandwidth of perhaps 20 hertz or greater, and the metering will smooth over most of the phase transitions in that signal. The designer feels that all of these signals may be treated as "essentially sinewaves" and that the meter should be interpreted as their rms values.

APPENDIX

Wiring Diagrams and Wire-Wrapped
Board Pin Assignments

BEST AVAILABLE COPY

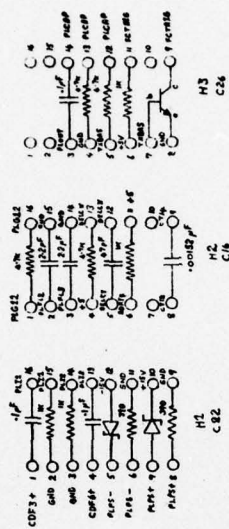
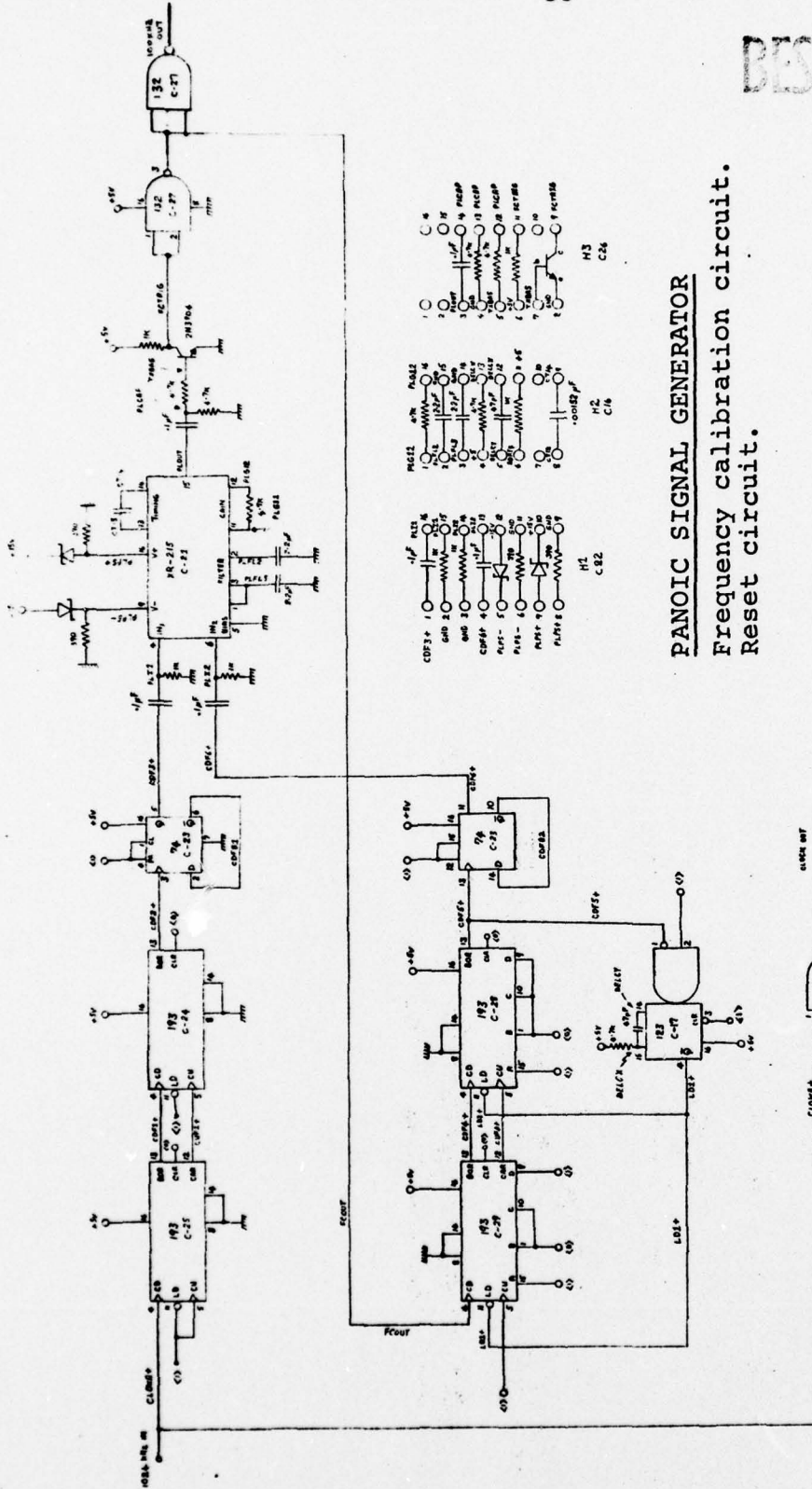

PANOIC SIGNAL GENERATOR
 Frequency calibration circuit.
 Reset circuit.

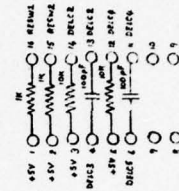

H4 B-65

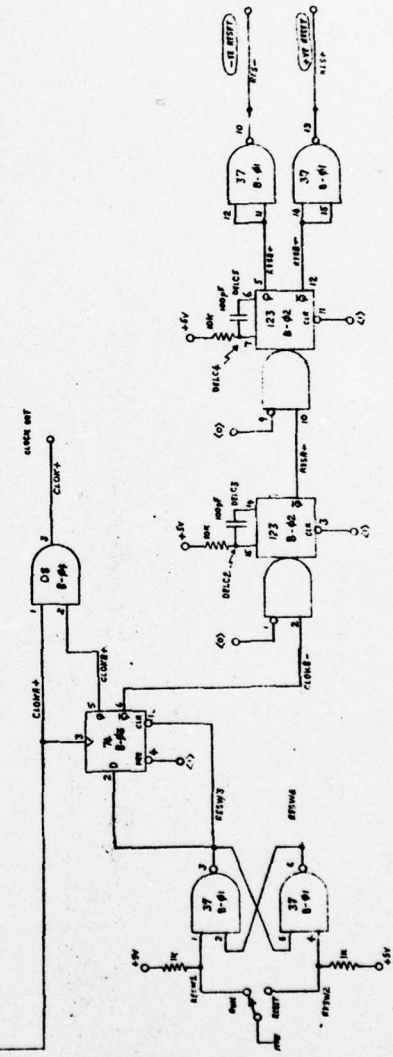

PRECEDING PAGE BLANK-NOT FILLED

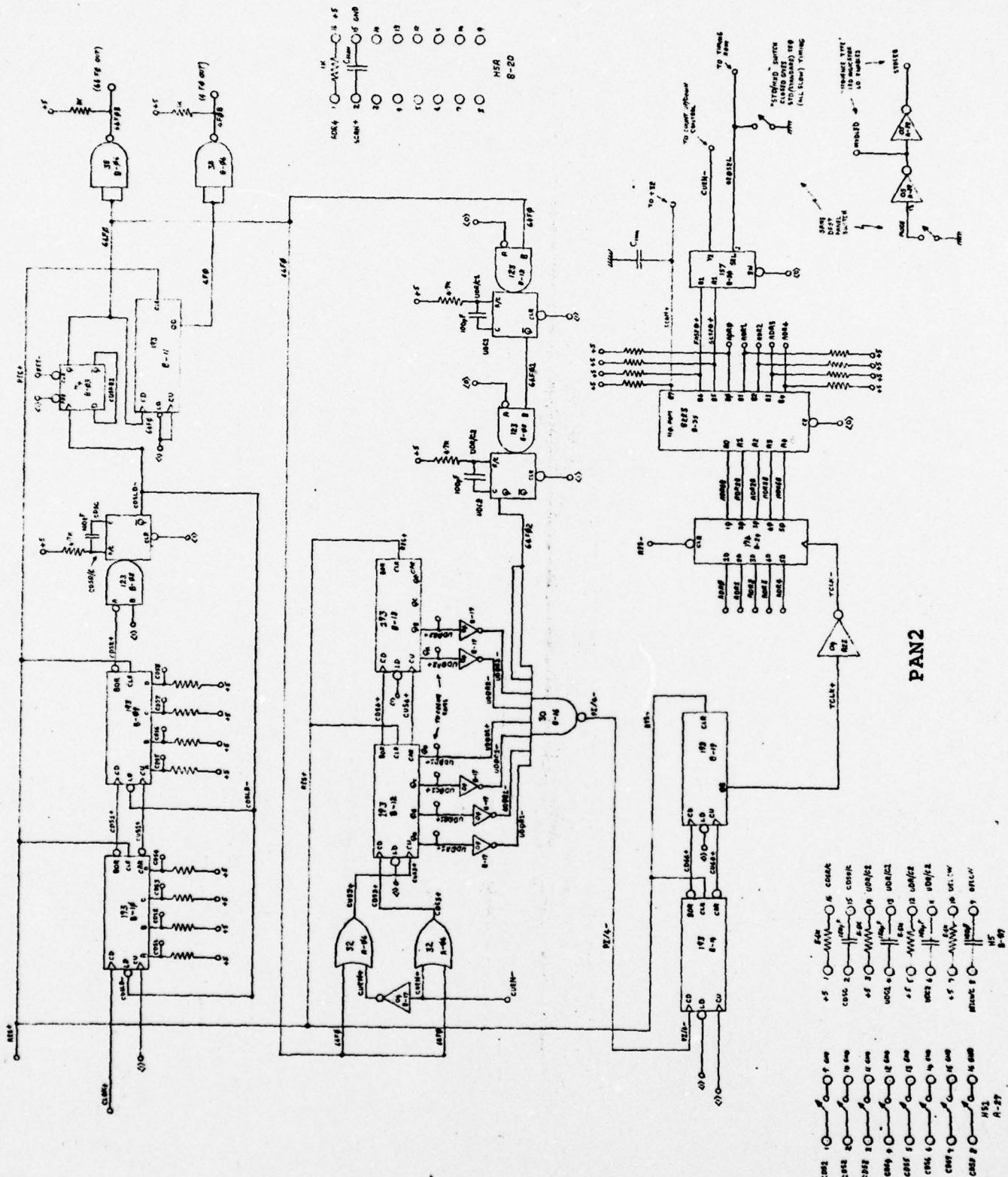

PAN 2

BEST AVAILABLE COPY

PRECEDING PAGE BLANK-NOT FILLED

BEST AVAILABLE COPY

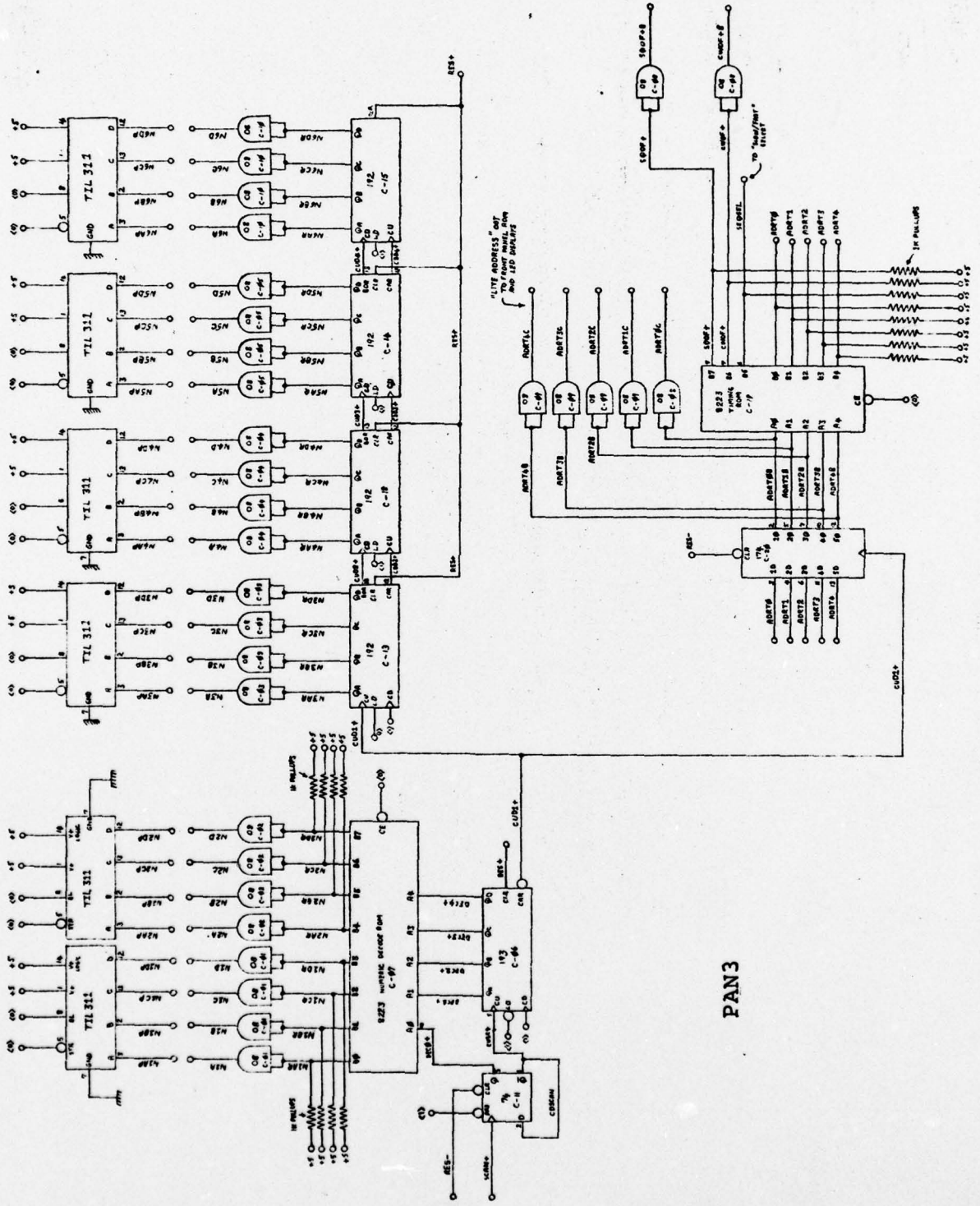

PRECEDING PAGE BLANK-NOT FILLED

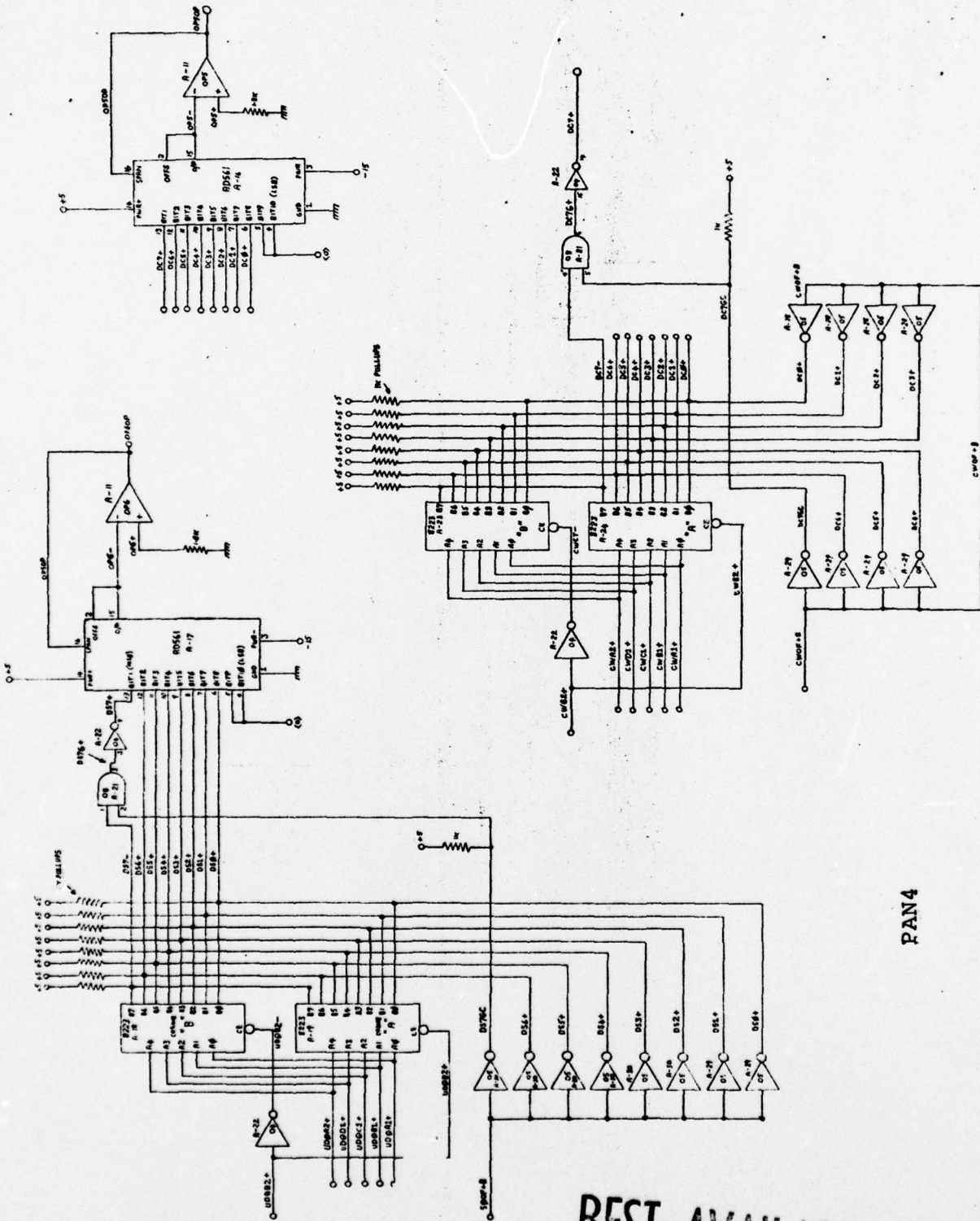

PAN4

BEST AVAILABLE COPY

FORWARDING PAGE BLANK-NOT FILLED

JUNE 09, 1977

PANIC SIGNAL GENERATOR 23APRIL77(GEJB)

BEST AVAILABLE COPY

A 1	A 2	A 3	A 4	A 5
17- 0- 16- 1-10V 15- 2-10V 14- 3-1V 13- 4-1V 12- 5-100MV 11- 6-100MV 10- 7-OP20P 9- 8-OP20P	17- 14-OP40P 16- 15-OP4- 15- 14-L101# 14- 13--15V 13- 12-OP3+ 12- 11-OP30P 11- 10-OP30P 9- 8-OP20P	17- H001# 16- OP3Z 15- OP3ZA 14- 15MON 13- 15MON 12- 5MON 11- OP3ZR 10- 7- 9- 8-	17- 0-L023# 16- 1-OP3ZA 15- 2- 14- 3- 13- 4- 12- 5- 11- 6- 10- 7-OP3ZA 9- 8-	17- 0-L024# 16- 1- 15- 2- 14- 3- 13- 4- 12- 5- 11- 6- 10- 7- 9- 8-

HEADER	HA4605	HEADER	HA4605	HEADER
A 6	A 7	A 8	A 9	A 10
17- H002# 16- H002# 15- 2-CUFN+ 14- 3-CUS3+ 13- 4-CUFN- 12- 5-44FO 11- 6-CUS3+ 10- 7-L002# 9- 8-	17- 16-004- 16- 15-OP4- 15- 14-OP4- 14- 13-OP40P 13- 12-OP40P 12- 11-L003# 11- 10-OP3+ 9- 8-OP3+	17- 0-L002# 16- 1-64FO 15- 2-CUFN+ 14- 3-CUS3+ 13- 4-CUFN- 12- 5-44FO 11- 6-CUS3+ 10- 7-L002# 9- 8-	17- 0- 16- 1- 15- 2- 14- 3- 13- 4- 12- 5- 11- 6- 10- 7- 9- 8-	17- 0- 16- 1- 15- 2- 14- 3- 13- 4- 12- 5- 11- 6- 10- 7- 9- 8-

7432	HEADER	HA4605	HEADER	HA4605
A 11	A 12	A 13	A 14	A 15
17- 0-L005# 16- 1-OP50P 15- 2-OP5- 14- 3-OP5+ 13- 4-+15V 12- 5-OP5+ 11- 6-OP5- 10- 7-OP50P 9- 8-	17- 16-OP7- 16- 15-OP7- 15- 14-OP7- 14- 13-OP5+ 13- 12- 12- 11- 11- 10-L004# 10- 9-L004# 9- 8-	17- 0-L007# 16- 1-OP90P 15- 2-OP9- 14- 3-OP9+ 13- 4-+15V 12- 5-OP10+ 11- 6-SIGOUT 10- 7-SIGOUT 9- 8-	17- 0-L008# 16- 1-OP80P 15- 2-OP80C 14- 3-OP80C 13- 4-L008# 12- 5-L008# 11- 6-OP80P 10- 7- 9- 8-	17- 0- 16- 1- 15- 2- 14- 3- 13- 4- 12- 5- 11- 6- 10- 7- 9- 8-

A16	A17	A18	A19	A20
17-H002#	17-H004#	0-L010#	17-H006#	17-H007#
16-H050#	16-H060#	1-L010#	16-H006#	16-H007#
15-H05-	15-H06-	2-H06-	15-H0082+	15-DC51+
14-H003#	14-H004#	3--15V	14-H00A2+	14-DC51+
13-H07+	13-H07+	4-L010#	13-H0001+	13-DC51+
12-H06+	12-H06+	5-L010#	12-H00C1+	12-DC51+
11-H05+	11-H05+	6-D05+	11-H00R1+	11-DC51+
10-H04+	10-H04+	7-H051+	10-H00A1+	10-DC51+
9-DC3+	9-NS3+	8-NS2+	9-DSZ-	9-DSIGC

RESNET

R223

R223

R223

A0561

A0561

A21	A22	A23	A24	A25
17-H008#	17-H008#	0-L013#	17-H011#	17-H012#
16-H008#	16-H008#	1-NS7-	16-H011#	16-H012#
15-	15-D07G+	2-NS7G	15-CWR2+	15-
14-	14-DCZ+	3-NS7G+	14-CWA2+	14-
13-	13-TCLK+	4-NS7+	13-CW01+	13-
12-	12-TCLK-	5-CWR2+	12-CW01+	12-
11-	11-	6-CW01-	11-CW01+	11-
10-	10-	7-L013#	10-CW01+	10-
9-	9-	8-	9-DCZ-	9-

RESNET

R223

R223

R223

7404

7404

A26	A27	A28	A29	A30
17-	17-	0-L017#	17-H014#	17-H015#
16-L017#	16-L017#	1-C0C1	16-H014#	16-H015#
15-L017#	15-L017#	2-C0C2	15-CW0F+R	15-S00F+R
14-L017#	14-L017#	3-C0C3	14-DC31	2-DS2+
13-L017#	13-L017#	4-C0C4	13-S00F+R	3-S00F+R
12-L017#	12-L017#	5-C0C5	12-DC51	4-DS2+
11-L017#	11-L017#	6-C0C6	11-S00F+R	5-S00F+R
10-L017#	10-L017#	7-C0C7	10-DC51	6-DS2+
9-L017#	9-L017#	8-C0C8	9-DCZ-	7-L021#

RESNET

R223

R223

R223

7405

7405

BEST AVAILABLE COPY

AJ2

- 1-0084
- 2-00700
- 3-FXTIN
- 4-FXTIN
- 5-00500
- 6-00600
- 7-115M0N
- 8-115M0N
- 9-15M0N
- 10-
- 11-+5L5N
- 12--15V
- 13-+15V
- 14-L001#
- 15-L001#
- 16-L001#
- 17-L001#
- 18-L022#
- 19-L022#
- 20-L022#
- 21-L022#
- 22-L023#
- 23-
- 24-L023#
- 25-L023#
- 26-L024#

AJ1

- 1-VSW1
- 2-10V
- 3-1V
- 4-1000V
- 5-VSW2
- 6-VE2
- 7-VE0
- 8-VB1
- 9-0014
- 10-SIG001
- 11-M0NSW1
- 12-M0NSW2
- 13-M0NSW2
- 14-L001#
- 15-L001#
- 16-L001#
- 17-L001#
- 18-L022#
- 19-L022#
- 20-L022#
- 21-L022#
- 22-L023#
- 23-L023#
- 24-L023#
- 25-L023#
- 26-L024#

R 1 R 2 R 3 R 4 R 5

17-H021#	0-L017#	17-H022#	0-L020#	17-H023#	0-L030#	17-H024#	0-L031#	17-H025#
16-H021#	1-RESW1	16-H022#	1-L020#	16-H023#	1-RESW3	16-H024#	1-CLKA+	16-RESW1
15-RECA-	2-RESW4	15-DELFC2	2-CLKA-	15-RES-	2-RESW3	15-	2-CLKA+	15-RESW2
14-RECA-	3-RESW3	14-DELFC3	3-H020#	14-CONSER1	3-CLKA+	14-	3-CLK+	14-DELFC2
13-RES+	4-RESW7	13-	4-RESA-	13-CONSLD-	4-H020#	13-	4-	13-DELFC3
12-RECA+	5-RESW3	12-RESB-	5-RESA-	12-H020#	5-CLKA+	12-	5-	12-DELFC4
11-RESA+	6-RESW4	11-H020#	6-DELFC5	11-6450	6-CLKA-	11-	6-	11-DELFC4
10-RES-	7-L031#	10-RESA-	7-DELFC4	10-CONSER1	7-L030#	10-	7-L031#	10-
9-	8-	9-L020#	8-L020#	9-	8-	9-	8-	9-

HEADER

740R

7474

74123

R 6 R 7 R 8 R 9 R 10

17-H024#	0-L034#	17-H027#	0-	17-H028#	0-L035#	17-H029#	0-L036#	17-H030#
16-H026#	1-6450	16-CONSP/C	1-H027#	16-H028#	1-L040#	16-H029#	1-CDS6	16-H030#
15-	2-6450	15-CONSP/C	2-CONC	15-CONSR/C	2-H020#	15-CONSS	2-	15-CDS1
14-	3-6450B	14-UNR/C1	3-H027#	14-CONSR	3-H020#	14-RES+	3-	14-RES+
13-	4-4FO	13-UNR/C1	4-UNCL	13-	4-CONSLD-	13-CONSS2	4-CDS1+	13-CDS1+
12-CWR2+	5-4FO	12-UNR/C2	5-H027#	12-	5-64502	12-	5-CUS1+	12-CUS1+
11-CWR2+	6-450B	11-UNR/C2	6-UNCL	11-H020#	5-UNCL	11-CONSLD-	6-	11-CONSLD-
10-ENCL	7-L034#	10-DELFCW	7-H027#	10-64501	7-UNR/C2	10-CONSS7	7-	10-CONSS3
9-	8-	9-DELFCW	8-DELFCW	9-L035#	8-L035#	9-CONSS8	8-L036#	9-CDS4

HEADER

74193

74123

HEADER

R 11 R 12 R 13 R 14 R 15

17-H031#	0-L038#	17-H032#	0-L030#	17-H033#	0-L040#	17-H034#	0-L041#	17-H035#
16-H031#	1-	16-H032#	1-	16-H033#	1-L040#	16-H034#	1-	16-H035#
15-	2-UNDR1+	15-	2-UNDR1+	15-UNR/C1	2-6450	15-	2-	15-ADR2
14-RES+	3-UNDR1+	14-RES+	3-UNDR1+	14-UNCL	3-H020#	14-RES+	3-	14-ADR2
13-	4-CONSS3+	13-CONSS4+	4-CONSS3+	13-	4-64501	13-CONSS4+	4-PI/4-	13-ADR1
12-	5-H020#	12-CONSS4+	5-CONSS3+	12-CONSLD-	5-CONSS3+	12-CONSS4+	5-H020#	12-ADR1
11-H020#	6-	11-UNDR1+	6-UNDR1+	11-H020#	5-DELFCW	11-H020#	6-	11-SLSE0+
10-	7-450	10-	7-UNDR1+	10-H020#	7-DELFCW	10-	7-	10-FASE0+
9-	8-L038#	9-	8-L038#	9-CONSS2+	9-L040#	9-	8-L041#	9-SCAN+

RESNET

74193

74123

74193

BEST AVAILABLE COPY

R16	R17	R18	R19	R20
17-H034#	17-H037#	17-H038#	17-H039#	17-H040#
16-H036#	16-H037#	16-H038#	16-H039#	16-H040#
15-	15-H00C1+	15-	15-	15-L046#
14-44502	14-H00C1-	14-RES+	14-RES+	14-
13-44502	13-H00A1+	13-	13-	13-
12-	12-H00A2+	12-	12-	12-
11-	11-H00A2-	11-H020#	11-H020#	11-
10-0174=	10-H00A2=	10-	10-	10-
9-	9-	9-	9-	9-
7430	7404	74193	74193	HEADFF
R21	R22	R23	R24	R25
17-H041#	17-H042#	17-H043#	17-H044#	17-H045#
16-H041#	16-H042#	16-H043#	16-H044#	16-H045#
15-	15-C00C	15-C0C1	15-	15-L051#
14-	14-055+	14-RES+	14-	14-ADR48
13-	13-C00C2+	13-C0C1+	13-ADR4	13-ADR3R
12-	12-4450C	12-C0C1+	12-ADR4R	12-ADR2R
11-	11-C0C10-	11-C0C10-	11-ADR3	11-ADR1R
10-	10-C0C7	10-C0C3	10-ADR3R	10-ADR0R
9-	9-C0C8	9-C0C4	9-TCLK-	9-SCAN±
0-L047#	0-L048#	0-L049#	0-L050#	0-L051#
1-RES-	1-C0C6	1-C0C2	1-RES-	1-ADR0
2-C0C8R1	2-	2-	2-ADR0R	2-ADR1
3-C0C3+	3-	3-	3-ADR0	3-ADR2
4-H020#	4-C0C1+	4-C0C1+	4-ADR1	4-ADR3
5-4450C	5-C0C1+	5-H020#	5-ADR1R	5-ADR4
6-C0C8R1	6-	6-	6-ADR2	6-SLSEQ±
7-L047#	7-	7-	7-ADR2R	7-EASEQ±
8-	8-L048#	8-L049#	8-L050#	8-L051#
7474	74103	74193	74174	R223
R26	R27	R28	R29	R30
17-H044#	17-H047#	17-H048#	17-H049#	17-H049#
16-H044#	16-H047#	16-H048#	16-H049#	16-H049#
15-	15-	15-	15-L054#	15-L054#
14-055+	14-055+	14-	14-	14-
13-	13-C0C4+	13-	13-H016#	13-FASFO+
12-	12-C0C4+	12-	12-L032#	12-
11-H020#	11-H020#	11-450R	11-L032#	11-
10-	10-	10-4450R	10-L032#	10-
9-	9-	9-E0C8	9-	9-
0-L054#	0-L053#	0-L054#	0-L055#	0-L054#
1-C0C2±	1-C0C1+	1-H048#	1-C0C1	1-SE0SEF
2-C0C2±	2-C0C1+	2-	2-C0C2	2-SLSEQ+
3-C0C2±	3-C0C1+	3-	3-C0C3	3-FASFO+
4-C0C4+	4-C0C4+	4-H020#	4-H020#	4-CUEN=
5-C0C4+	5-4450C	5-4450C	5-L032#	5-
6-	6-	6-C0C1+	6-L032#	6-
7-	7-	7-C0C1+	7-L032#	7-
8-L052#	8-L053#	8-L054#	8-	8-L054#
74193	74103	RESNET	7437	74157

PRECEDING PAGE BLANK-NOT FILMED

BEST AVAILABLE COPY

RJ2

- 1-
- 2-
- 3-
- 4-
- 5-
- 6-
- 7-
- 8-
- 9-
- 10-
- 11-
- 12-
- 13-
- 14-
- 15-
- 16-
- 17-
- 18-
- 19-
- 20-
- 21-
- 22-
- 23-
- 24-
- 25-
- 26-

RJ1

- 1-+FLEN
- 2-L0204
- 3-L0204
- 4-L0204
- 5-L0304
- 6-L0304
- 7-L0304
- 8-L0304
- 9-S'DLEN
- 10-MYDLEN
- 11-
- 12-
- 13-
- 14-+FLEN
- 15-L0204
- 16-ADPTOC
- 17-ADPTIC
- 18-ADPT2C
- 19-ADPT3C
- 20-ADPT4C
- 21-L0304
- 22-L0314
- 23-L0314
- 24-L0314
- 25-L0314
- 26-

BEST AVAILABLE COPY

C 1 C 2 C 3 C 4 C 5

17-H050#	17-H051#	17-H052#	17-H053#	17-H054#	17-H055#	17-H056#	17-H057#	17-H058#	17-H059#	17-H060#	17-H061#	17-H062#	17-H063#	17-H064#	17-H065#	17-H066#	17-H067#	17-H068#	17-H069#	17-H070#
16-H050#	16-H051#	16-H052#	16-H053#	16-H054#	16-H055#	16-H056#	16-H057#	16-H058#	16-H059#	16-H060#	16-H061#	16-H062#	16-H063#	16-H064#	16-H065#	16-H066#	16-H067#	16-H068#	16-H069#	16-H070#
15-N100	15-N101	15-N102	15-N103	15-N104	15-N105	15-N106	15-N107	15-N108	15-N109	15-N110	15-N111	15-N112	15-N113	15-N114	15-N115	15-N116	15-N117	15-N118	15-N119	15-N120
14-N100	14-N101	14-N102	14-N103	14-N104	14-N105	14-N106	14-N107	14-N108	14-N109	14-N110	14-N111	14-N112	14-N113	14-N114	14-N115	14-N116	14-N117	14-N118	14-N119	14-N120
13-N100	13-N101	13-N102	13-N103	13-N104	13-N105	13-N106	13-N107	13-N108	13-N109	13-N110	13-N111	13-N112	13-N113	13-N114	13-N115	13-N116	13-N117	13-N118	13-N119	13-N120
12-N100	12-N101	12-N102	12-N103	12-N104	12-N105	12-N106	12-N107	12-N108	12-N109	12-N110	12-N111	12-N112	12-N113	12-N114	12-N115	12-N116	12-N117	12-N118	12-N119	12-N120
11-N100	11-N101	11-N102	11-N103	11-N104	11-N105	11-N106	11-N107	11-N108	11-N109	11-N110	11-N111	11-N112	11-N113	11-N114	11-N115	11-N116	11-N117	11-N118	11-N119	11-N120
10-N100	10-N101	10-N102	10-N103	10-N104	10-N105	10-N106	10-N107	10-N108	10-N109	10-N110	10-N111	10-N112	10-N113	10-N114	10-N115	10-N116	10-N117	10-N118	10-N119	10-N120
9-	9-	9-	9-	9-	9-	9-	9-	9-	9-	9-	9-	9-	9-	9-	9-	9-	9-	9-	9-	9-

7408

7409

7408

7408

7408

C 10

C 9

C 8

C 7

C 6

17-H055#	17-H056#	17-H057#	17-H058#	17-H059#	17-H060#	17-H061#	17-H062#	17-H063#	17-H064#	17-H065#	17-H066#	17-H067#	17-H068#	17-H069#	17-H070#					
16-H055#	16-H056#	16-H057#	16-H058#	16-H059#	16-H060#	16-H061#	16-H062#	16-H063#	16-H064#	16-H065#	16-H066#	16-H067#	16-H068#	16-H069#	16-H070#					
15-	15-	15-	15-	15-	15-	15-	15-	15-	15-	15-	15-	15-	15-	15-	15-	15-	15-	15-	15-	15-
14-REC+	14-REC+	14-REC+	14-REC+	14-REC+	14-REC+	14-REC+	14-REC+	14-REC+	14-REC+	14-REC+	14-REC+	14-REC+	14-REC+	14-REC+	14-REC+	14-REC+	14-REC+	14-REC+	14-REC+	14-REC+
13-	13-	13-	13-	13-	13-	13-	13-	13-	13-	13-	13-	13-	13-	13-	13-	13-	13-	13-	13-	13-
12-CUD1+	12-CUD1+	12-CUD1+	12-CUD1+	12-CUD1+	12-CUD1+	12-CUD1+	12-CUD1+	12-CUD1+	12-CUD1+	12-CUD1+	12-CUD1+	12-CUD1+	12-CUD1+	12-CUD1+	12-CUD1+	12-CUD1+	12-CUD1+	12-CUD1+	12-CUD1+	12-CUD1+
11-H020#	11-H020#	11-H020#	11-H020#	11-H020#	11-H020#	11-H020#	11-H020#	11-H020#	11-H020#	11-H020#	11-H020#	11-H020#	11-H020#	11-H020#	11-H020#	11-H020#	11-H020#	11-H020#	11-H020#	11-H020#
10-	10-	10-	10-	10-	10-	10-	10-	10-	10-	10-	10-	10-	10-	10-	10-	10-	10-	10-	10-	10-
9-	9-	9-	9-	9-	9-	9-	9-	9-	9-	9-	9-	9-	9-	9-	9-	9-	9-	9-	9-	9-

7408

7408

7408

7408

7408

C 15

C 14

C 13

C 12

C 11

17-H060#	17-H061#	17-H062#	17-H063#	17-H064#	17-H065#	17-H066#	17-H067#	17-H068#	17-H069#	17-H070#
16-H060#	16-H061#	16-H062#	16-H063#	16-H064#	16-H065#	16-H066#	16-H067#	16-H068#	16-H069#	16-H070#
15-	15-	15-	15-	15-	15-	15-	15-	15-	15-	15-
14-	14-	14-	14-	14-	14-	14-	14-	14-	14-	14-
13-	13-	13-	13-	13-	13-	13-	13-	13-	13-	13-
12-	12-	12-	12-	12-	12-	12-	12-	12-	12-	12-
11-	11-	11-	11-	11-	11-	11-	11-	11-	11-	11-
10-	10-	10-	10-	10-	10-	10-	10-	10-	10-	10-
9-	9-	9-	9-	9-	9-	9-	9-	9-	9-	9-

7412

7412

7412

7412

7412

BEST AVAILABLE COPY

PRECEDING PAGE BLANK-NOT FILMED

C16	C17	C18	C19	C20
17-H045#	17-H066#	17-H057#	17-H068#	17-H069#
16-PLC12	17-H066#	14-H067#	16-H068#	16-H069#
15-L045#	14-H066#	15-H067#	15-L068#	15-ADRI1
14-L045#	15-DELFCX	14-RFS+	14-ADRI2	14-ADRT1
13-DELFCX	14-DELFCY	13-CUD1+	13-ADRI3	13-ADRT4
12-DELFCX	13-DELFCY	12-CUD2+	12-ADRI4	12-ADRI4A
11-H045#	12-DELFCY	11-H010#	11-ADRI1A	11-ADRT3
10-CT14	11-DELFCY	10-DELFCY	10-ADRI2A	10-ADRI3A
	10-DELFCY	9-L066#	9-CUDE+	9-CUD1+
	9-CT13		8-L068#	8-L069#
HEADER	74123	74192	9223	74174
C21	C22	C23	C24	C25
17-PLPS+	17-L070#	17-H070#	17-H071#	17-H072#
16-PLCUT	1-PLFL3	16-H070#	16-H071#	16-H072#
14-CT14	2-PLFL2	15-H019#	15-ADRI1	15-ADRI2
13-CT13	3-PLFL3	14-DELFC2	14-L073#	14-L074#
12-PLG12	4-PLFL4	13-DELFC3	13-CDE2+	13-CDE1+
11-PLG11	5-L070#	12-PLPS-	12-ADRI1	12-CUE1+
10-PLPS-	6-PLFL2	11-DELFC1	11-H019#	11-H019#
	7-PLFL1	10-DELFC2	10-ADRI1	10-ADRI2
	8-PLPS-	9-PLPS+	9-L073#	9-L074#
XP215	HEADER	7474	74193	74193
C26	C27	C28	C29	C30
17-H073#	17-H074#	17-H075#	17-H076#	17-H077#
16-PLCAP	14-H074#	15-H075#	16-H076#	16-L078#
15-PLCAP	15-H074#	14-H019#	15-H019#	1-L078#
13-PLCAP	14-PLCAP	13-DELFC3	14-L078#	2-ADRI1
12-PLCAP	13-PLCAP	12-DELFC4	13-CDE4+	3-ADRI2
11-FCT91G	12-PLCAP	11-L01+	12-CUE4+	4-ADRI3
10-PLCAP	11-FCT91G	10-L077#	11-L01+	5-ADRI4
	9-FCT91G	9-L077#	10-L078#	6-ADRI2
			9-H019#	7-ADRI3A
HEADER	74132	74193	74193	8-L069#

BEST AVAILABLE COPY

BEST AVAILABLE COPY

CJI	CJP
1-100KHZ	1-N2A
2-250KHZ	2-N2R
3-RECVD	3-N3C
4-24500	4-N3D
5-450R	5-N3A
6-SECSSEL	6-N3R
7-EDCW	7-+5LFD
8-2030D	8-N4C
9-+5LEO	9-N4D
10-WIDE	10-N4A
11-	11-N4R
12-	12-N5C
13-CLOWAS	13-N5D
14-L025H	14-N7D
15-L025H	15-N2C
16-L025H	16-N1R
17-L025H	17-N1A
18-L024H	18-N1D
19-L024H	19-N1C
20-L024H	20-L024H
21-L024H	21-N6R
22-L027H	22-N6A
23-L027H	23-N6D
24-	24-N4C
25-	25-N6R
26-L078H	26-N6A

PREVIOUS PAGE BLANK-NOT FILMED

TOTAL NUMBER OF NETS IS 443
LONGEST NET IS 31 DIMS
TOTAL NUMBER OF MODULES IS 90
TOTAL NUMBER OF WIRES IS 940
TOTAL LENGTH OF WIRE IS 76.7 FEET
TOTAL POWER CONSUMPTION IS 12850 MW
TOTAL CARDS PUNCHED IS 940

PRECEDING PAGE BLANK-NOT FILLED

PANOIC77 POWER SUPPLY

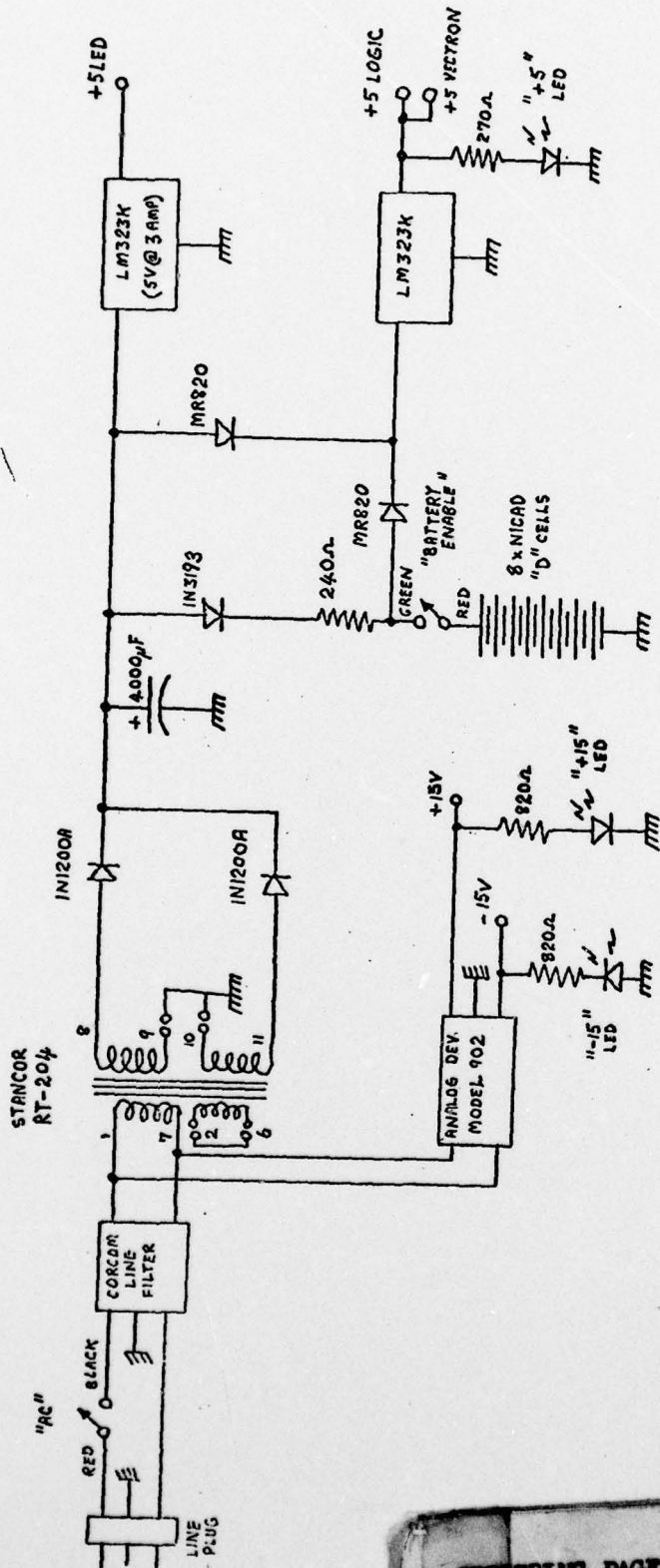

PRECEDING PAGE BLANK-NOT FILMED

DISTRIBUTION LIST

	<u>No. of Copies</u>
Office of Naval Research Department of the Navy Arlington, Virginia 22217 Attn: Code 222	2
102-OS	1
480	1
Director Naval Research Laboratory Technical Information Division Washington, D.C. 20375	6
Director Office of Naval Research Branch Office 1030 East Green Street Pasadena, California 91106	1
Office of Naval Research San Francisco Area Office 760 Market Street - Room 447 San Francisco, California 94102	1
Director Office of Naval Research Branch Office 495 Summer Street Boston, Massachusetts 02210	1
Office of Naval Research New York Area Office 715 Broadway (5th Floor) New York, New York 10003	1
Director Office of Naval Research Branch Office 536 South Clark Street Chicago, Illinois 60605	1
Commander Naval Surface Weapons Center Acoustics Division White Oak Silver Spring, Maryland 20910 Attn: Dr. Zaka Slawsky	1

Officer in Charge Annapolis Laboratory Naval Ship Research & Development Center Annapolis, Maryland 21402	1
Commander Naval Sea Systems Command Washington, D.C. 20362 Attn: Code SEA 037	1
Commander Naval Sea Systems Command Washington, D.C. 20362 Attn: Mr. Carey Smith, SEA 06H1	1
Commanding Officer Fleet Numerical Weather Central Monterey, California 93940	1
Defense Documentation Center Cameron Station Alexandria, Virginia 22314	5
Chief of Naval Materials 2211 Jefferson Davis Highway Crystal Plaza #5 Arlington, Virginia 20360 Attn: Mr. James Probus (Director of Navy Laboratories) NAVMAT 03L	1
Commander Naval Electronic Systems Command Washington, D.C. 20360 Attn: CDR A. Miller, NAVELEX 320	1
Commander David W. Taylor Naval Ship Research & Development Center Bethesda, Maryland 20084 Attn: Mr. Craig Olson Unclassified Library	1 1
Chief of Naval Operations Department of the Navy Pentagon Room 4D518 Washington, D.C. 20350 Attn: Capt. A. H. Gilmore	1

Commander Naval Undersea Center San Diego, California 92132 Attn: Dr. Dan Andrews Mr. Henry Aurand	1 1
Chief Scientist Navy Underwater Sound Reference Division P.O. Box 8337 Orlando, Florida 32806	1
Officer in Charge New London Laboratory Naval Underwater Systems Center New London, Connecticut 06320 Attn: Dr. A. Nuttall Dr. D. M. Viccione Mr. A. W. Ellinthorpe	3
Commander Naval Air Development Center Warminster, Pennsylvania 18974 Attn: Unclassified Library	1
Superintendent Naval Postgraduate School Monterey, California 93940 Attn: Unclassified Library	1
Commanding Officer Naval Coastal Systems Laboratory Panama City, Florida 32401 Attn: Unclassified Library	1
Commanding Officer Naval Underwater Systems Center Newport, Rhode Island 02840 Attn: Unclassified Library	1
Superintendent U.S. Naval Academy Annapolis, Maryland 21402	1
Commanding Officer Naval Intelligence Support Center 4301 Suitland Road Suitland, Maryland 20390 Attn: Dr. Johann Martinek Mr. E. Bissett	1 1

Commander Naval Sea Systems Command Washington, D.C. 20362 Attn: Unclassified Library, SEA 03E	1
Dr. Melvin J. Jacobson Rensselaer Polytechnic Institute Troy, New York 12181	1
Dr. Alan Winder MSB Systems, Inc. 25 Sylvan Road South West Point, Connecticut 06880	1
Dr. Charles Stutt General Electric Company P.O. Box 1088 Schenectady, New York 12301	1
Dr. T. G. Birdsall Cooley Electronics Laboratory University of Michigan Ann Arbor, Michigan 48109	1
Dr. Harry DeFerrari University of Miami Rosenstiel School of Marine & Atmospheric Sciences 4600 Rickenbacker Causeway Miami, Florida 33149	1
Mr. Robert Cunningham Bendix Electronics Center 15825 Roxford Street Sylmar, California 91342	1
Dr. Stephen Wolff John Hopkins University Baltimore, Maryland 21218	1
Dr. M. A. Basin S.D.P., Inc. 15250 Ventura Boulevard Suite 518 Sherman Oaks, California 91403	1
Dr. Walter Duing University of Miami Rosenstiel School of Marine & Atmospheric Sciences 4600 Rickenbacker Causeway Miami, Florida 33149	1

Dr. David Middleton 127 East 91st Street New York, New York 10028	1
Dr. Donald W. Tufts University of Rhode Island Kingston, Rhode Island 02881	1
Dr. Loren Nolte Duke University Department of Electrical Engineering Durham, North Carolina 27706	1
Mr. S. W. Autrey Hughes Aircraft Company P.O. Box 3310 Fullerton, California 92634	1
Dr. Thomas W. Ellis Texas Instruments, Inc. 13500 North Central Expressway Dallas, Texas 75231	1
Mr. Robert Swarts Applied Physics Laboratory University of Washington 1013 Northeast Fortieth Street Seattle, Washington 98195	1
Institute for Acoustical Research Miami Division of the Palisades Geophysical Institute 615 S.W. 2nd Avenue Miami, Florida 33130 Attn: Mr. M. Kronengold Dr. J. Clark Dr. W. Jobst Dr. S. Adams	2
Mr. Carl Hartdegen Palisades Geophysical Institute Sofar Station PPO New York 09560	1
Mr. Charles Loda Institute for Defense Analyses 400 Army-Navy Drive Arlington, Virginia 22202	1

Mr. Beaumont Buck
Polar Research Laboratory
123 Santa Barbara Avenue
Santa Barbara, California 93101 1

Dr. M. Weinstein
Underwater Systems, Inc.
8121 Georgia Avenue
Silver Spring, Maryland 20910 1

Mr. Thomas G. Kincaid
General Electric Company
P.O. Box 1088
Schenectady, New York 12301 1

Applied Research Laboratories
University of Texas at Austin
P.O. Box 8029
10000 FM Road 1325
Austin, Texas 78712 2
Attn: Dr. Lloyd Hampton
Dr. Charles Wood
Dr. T. D. Plemons

Woods Hole Oceanographic Institution
Woods Hole, Massachusetts 02543 1
Attn: Dr. Paul McElroy
Dr. R. Porter
Dr. R. Spindel

Mr. John Bouyoucos
Hydroacoustics, Inc.
321 Northland Avenue
P.O. Box 3813
Rochester, New York 14610 1

Systems Control, Inc.
260 Sheridan Avenue
Palo Alto, California 94306
Attn: Mr. Robert Baron 1

Atlantic Oceanographic
& Meteorological Laboratories
15 Rickenbacker Causeway
Miami, Florida 33149
Attn: Dr. John Proni 1

Dr. C. N. K. Mooers
University of Miami
Rosenstiel School of Marine
& Atmospheric Sciences
4600 Rickenbacker Causeway
Miami, Florida 33149 1

Westinghouse Electric Corporation Advanced Development Program Marketing Department - MS 227 P.O. Box 746 Baltimore, Maryland 21203 Attn: F. J. Frissyn	1
Oak Ridge National Laboratory Union Carbide Corporation Nuclear Division P.O. Box X Oak Ridge, Tennessee 37830	1
Professor Neil Bershad University of California, Irvine School of Engineering Irvine, California 92664	1
Stuart Schwartz Princeton University Department of Electrical Engineering Brackett Hall, Engineering Quad. Princeton, New Jersey 08540	1
Ray Veenkant Texas Instruments Inc. North Central Expressway MS 208 Dallas, Texas 75222	1
Dr. C. V. Kimball University of Miami Rosenstiel School of Marine & Atmospheric Sciences 10 Rickenbacker Causeway Miami, Florida 33149	1
Cooley Electronics Laboratory University of Michigan Ann Arbor, Michigan 48109	25