

AD-A053 188

TRANSPORTATION SYSTEMS CENTER CAMBRIDGE MASS
PERFORMANCE OF A Q-M/PSK DATA MODEM OPERATING IN A VOICE AND DA--ETC(U)
FEB 78 J GOLAB, C DUNCOMBE

F/G 17/2

DOT-TSC-531

UNCLASSIFIED

TSC-FAA-77-28

FAA-RD-78-6

NL

1 of 1
AD
A053188



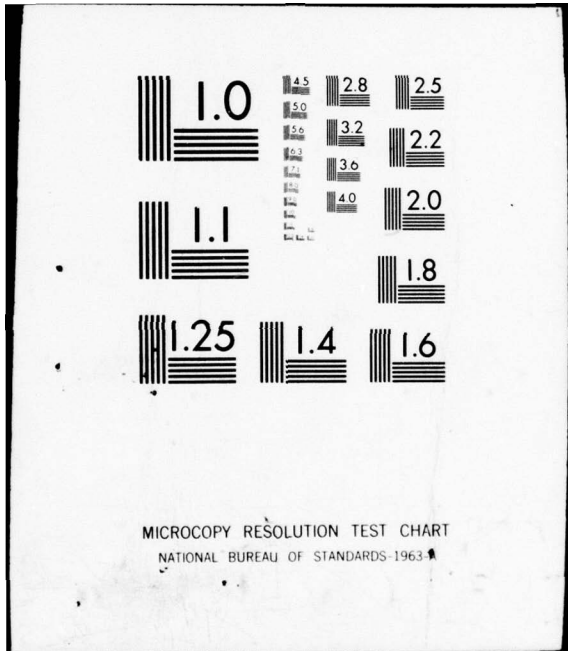

REPORT NO. FAA-RD-78-6

13
B.S.

PERFORMANCE OF A Q-M/PSK DATA MODEM OPERATING
IN A VOICE AND DATA MODE THROUGH THE ATS-6 SATELLITE

J. Golab
C. Duncombe

U.S. Department of Transportation
Transportation Systems Center
Kendall Square
Cambridge MA 02142

AD A 053188

DDC FILE COPY



DDC
APR 25 1978
F

FEBRUARY 1978

FINAL REPORT

DOCUMENT IS AVAILABLE TO THE U.S. PUBLIC
THROUGH THE NATIONAL TECHNICAL
INFORMATION SERVICE, SPRINGFIELD,
VIRGINIA 22161

Prepared for

U.S. DEPARTMENT OF TRANSPORTATION
FEDERAL AVIATION ADMINISTRATION
Systems Research and Development Service
Washington DC 20591

(13)

PERFORMANCE OF A D-MPSK DATA MODEM OPERATING
IN A VOICE AND DATA MODE THROUGH THE ATS-6 SATELLITE

NOTICE

This document is disseminated under the sponsorship of the Department of Transportation in the interest of information exchange. The United States Government assumes no liability for its contents or use thereof.

881820A0A

NOTICE

The United States Government does not endorse products or manufacturers. Trade or manufacturers' names appear herein solely because they are considered essential to the object of this report.

DDC LIFE COPY
ON 11/17/70

U.S. DEPARTMENT OF TRANSPORTATION
RESEARCH AND DEVELOPMENT SERVICE
WASHINGTON, DC 20590

Technical Report Documentation Page

<p>1. Report No. FAA-RD-78-6 ✓</p>	<p>2. Government Accession No.</p>	<p>3. Recipient's Catalog No.</p>
<p>4. Title and Subtitle PERFORMANCE OF A Q-M/PSK DATA MODEM OPERATING IN A VOICE AND DATA MODE THROUGH THE ATS-6 SATELLITE.</p>	<p>5. Report Date February 1978</p>	<p>6. Performing Organization Code</p>
<p>7. Author(s) J. Golab C. Duncombe</p>	<p>8. Performing Organization Report No. DOT-TSC-FAA-77-28</p>	<p>10. Work Unit No. (TRAIS) FA836/R8122</p>
<p>9. Performing Organization Name and Address U.S. Department of Transportation Transportation Systems Center ✓ Kendall Square Cambridge MA 02142</p>	<p>11. Contract or Grant No. DOT-TSC-531 <i>New</i></p>	<p>13. Type of Report and Period Covered Final Report, Jan 1977 - Aug 1977</p>
<p>12. Sponsoring Agency Name and Address U.S. Department of Transportation Federal Aviation Administration Systems Research and Development Service Washington DC 20591</p>	<p>14. Sponsoring Agency Code</p>	<p>15. Supplementary Notes 1229p.</p>
<p>16. Abstract</p> <p>Experiments were conducted in cooperation with the Communications Research Center (CRC) of Canada to gather additional performance data on the error statistics of the digital data channel of the Q-M/PSK Voice and Data Modem, while operating in the hybrid (simultaneous) voice and data mode. These data are to supplement the data collected in the 1974-75 ATS-6 satellite tests to provide additional information about the performance of the data portion of the modem when operating in a gaussian noise (no multipath) environment.</p> <p>Flight tests were conducted from 14 to 24 March 1977, in three locations: two in Canada at a 90° elevation angle to the satellite and one near Bermuda at a 50° elevation angle. Signals were transmitted from the Communications Research Center ground station at L-Band (1650 MHz) to the ATS-6 where they were relayed to the aircraft at 1550 MHz and received and recorded for post-flight tests.</p> <p>All flight tests were successfully completed and a large amount of data were collected. Results indicate a bit error rate on the order of 2 dB closer to theoretical for DECPK than in the previous ATS-6 tests, and in close agreement with laboratory and acceptance test data.</p>		
<p>17. Key Words Q-M/PSK, Hybrid, Slot-Dipole, Phased Array, Bit-Error, Elevation Angle, Multipath, ATS-6 Satellite</p>	<p>18. Distribution Statement DOCUMENT IS AVAILABLE TO THE U.S. PUBLIC THROUGH THE NATIONAL TECHNICAL INFORMATION SERVICE, SPRINGFIELD, VIRGINIA 22161</p>	
<p>19. Security Classif. (of this report) Unclassified</p>	<p>20. Security Classif. (of this page) Unclassified</p>	<p>21. No. of Pages 30</p>
<p>22. Price</p>		

407082

LB

PREFACE

The Transportation Systems Center (TSC), under the sponsorship of the FAA, Systems Research and Development Service, has been involved in the development of advanced voice/data multiplexed modems applicable to ground-aircraft communications via satellite in support of the AEROSAT program. TSC participated with the Department of Communications, Communications Research Center (CRC) of Canada, in the planning and conducting of recent flight tests to gather performance data on the error statistics of the digital channel of the TSC Q-M/PSK voice and data modem.

The Canadian (CRC) test program was intended to provide data to establish the bit-error-rate performance of a Canadian DECPSK modem and to compare the performance of the modem under operational flight conditions when using a linear phased array antenna with the performance achieved using a slot-dipole antenna system.

ACCESSION for	
NTIS	Write Section <input checked="" type="checkbox"/>
DDC	Buff Section <input type="checkbox"/>
UNANNOUNCED	<input type="checkbox"/>
JUSTIFICATION	
BY _____	
DISTRIBUTION/AVAILABILITY CODES	
_____ CIAL	
A	

METRIC CONVERSION FACTORS

Approximate Conversions to Metric Measures

Symbol	When You Know	Multiply by	To Find	Symbol
LENGTH				
in	inches	2.5	centimeters	cm
ft	feet	30	centimeters	cm
yd	yards	0.9	meters	m
mi	miles	1.6	kilometers	km
AREA				
sq ft	square inches	6.5	square centimeters	cm ²
sq ft	square feet	0.09	square meters	m ²
sq yd	square yards	0.8	square meters	m ²
sq mi	square miles	2.6	square kilometers	km ²
acres	acres	0.4	hectares	ha
MASS (weight)				
oz	ounces	28	grams	g
lb	pounds	0.45	kilograms	kg
	short tons (2000 lb)	0.9	tonnes	t
VOLUME				
teaspoon	teaspoons	5	milliliters	ml
Tablespoon	tablespoons	15	milliliters	ml
fluid ounce	fluid ounces	30	milliliters	ml
cup	cup	0.24	liters	l
pt	pints	0.47	liters	l
qt	quarts	0.95	liters	l
gal	gallons	3.8	liters	l
cu ft	cubic feet	0.03	cubic meters	m ³
cu yd	cubic yards	0.76	cubic meters	m ³
TEMPERATURE (exact)				
°F	Fahrenheit temperature	5-9 (after subtracting 32)	Celsius temperature	°C

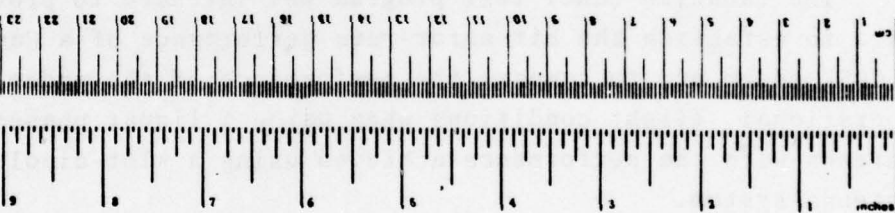

Approximate Conversions from Metric Measures

Symbol	When You Know	Multiply by	To Find	Symbol
LENGTH				
mm	millimeters	0.04	inches	in
cm	centimeters	0.4	inches	in
m	meters	3.3	feet	ft
m	meters	1.1	yards	yd
km	kilometers	0.6	miles	mi
AREA				
sq cm	square centimeters	0.16	square inches	sq in
sq m	square meters	1.2	square yards	sq yd
sq km	square kilometers	0.4	square miles	sq mi
ha	hectares (10,000 m ²)	2.5	acres	acres
MASS (weight)				
g	grams	0.035	ounces	oz
kg	kilograms	2.2	pounds	lb
t	tonnes (1000 kg)	1.1	short tons	short tons
VOLUME				
ml	milliliters	0.03	fluid ounces	fl oz
l	liters	2.1	pints	pt
l	liters	1.06	quarts	qt
l	liters	0.26	gallons	gal
m ³	cubic meters	36	cubic feet	cu ft
m ³	cubic meters	1.3	cubic yards	cu yd
TEMPERATURE (exact)				
°C	Celsius temperature	9/5 (then add 32)	Fahrenheit temperature	°F

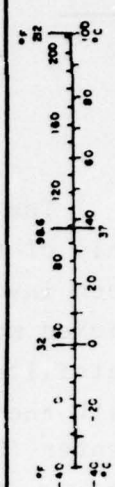

CONTENTS

<u>Section</u>		<u>Page</u>
1.	INTRODUCTION.....	1
2.	BACKGROUND.....	2
3.	SYSTEM DESCRIPTION.....	5
	3.1 Ground Station.....	5
	3.2 Airborne Equipment.....	5
	3.3 Calibration.....	10
4.	TEST DESCRIPTION.....	13
	4.1 Test Requirements.....	13
	4.2 System Integration Tests.....	13
	4.3 Flight Tests.....	14
5.	TEST RESULTS.....	15
	5.1 Ottawa, Canada.....	15
	5.2 Churchill, Manitoba.....	17
	5.3 Bermuda (Atlantic Ocean).....	19
6.	SUMMARY AND CONCLUSIONS.....	21
	REFERENCES.....	23

LIST OF ILLUSTRATIONS

<u>Figure</u>		<u>Page</u>
1.	Bit-Error-Rate Performance.....	3
2.	Block Diagram - Ground Station Configuration.....	6
3.	Block Diagram of Airborne Equipment.....	7
4.	Summary of Measured Gain Results for Slot-Dipole Antennas from 1975 and 1976 Tests.....	8
5.	Summary of Measured Gain Results for Phased Array Antenna from 1975 and 1976 Tests.....	9
6.	Block Diagram - Calibration Set-Up.....	11
7.	C/No Meter Readout vs. Calibrated C/No Q-M/PSK Modem.....	12
8.	Probability of Bit Error vs. Carrier to Noise Density Ratio for DECPSK Modem (Voice and Data Mode, at 1200 BPS) -- Ottawa Canada.....	16
9.	Probability of Bit Error vs Carrier to Noise Density Ratio for DECPSK Modem (Voice and Data Mode, at 1200 BPS) -- Churchill Manitoba.....	18
10.	Probability of Bit Error vs Carrier to Noise Density Ratio for DECPSK Modem (Voice and Data Mode, at 1200 BPS) -- Bermuda.....	20

1. INTRODUCTION

The Transportation Systems Center (TSC), under the sponsorship of the FAA, (ARD-230), has been involved in developmental and experimental efforts to conduct laboratory and flight tests of newly developed avionic components for aeronautical satellite communications systems. Early in 1977, TSC participated with the Communications Research Center (CRC) of Canada in the planning and scheduling of flight tests using the NASA ATS-6 satellite.

The purpose of the TSC experiments was to gather additional performance data on the QM/PSK voice and data modem, (Ref.1), while operating in primarily the hybrid, simultaneous voice and data mode. These data are potentially of great importance because they could provide the necessary additional information to be used in investigating the inconsistencies of the data obtained during the previous ATS-6 experiments with that obtained in the TSC laboratory.

2. BACKGROUND

Extensive testing of digital data modems was conducted by DOT/TSC with the ATS-6 satellite during the fall of 1974 and spring of 1975. The tests were performed under a large number of selected test conditions and the results were presented in a final test report. (See Reference 2, Volume VI, Section 5.) The data analyses and conclusions presented in this section reported a possible disparity of the results obtained with the Q-M/PSK modem operating in the simultaneous voice and data mode during test conditions with high C/No (over 43 db-Hz). The particular applicable paragraphs from the above reference that address the suspected problem are included herein:

"It is noted that the experimental data for the Hybrid No. 1 modem (Q-M/PSK Modem) show a rather dramatic divergence from the theoretical data-only performance at low bit-error rates. Data channel performance is, in fact, expected to be somewhat dependent upon the voice channel due to the speech/data adaptive power-sharing techniques inherent in the design of the modem. It is also reasonable to expect the effects of speech/data adaptive power sharing to be most readily observable at low bit-error rates because the error probability is more dominated by the infrequent peaks in the speech signal that reduce the effective power available to the data channel. Although the general behavior apparent in the experimental result is partially supportable by the above considerations, the acceptance test data furnished by the modem manufacturer and laboratory measurements made by DOT/TSC after completion of the field tests do not show the large divergence observed in the experimental data. Laboratory performance measurements for both the data-only and hybrid voice/data modes are included in figure 5-23." (See Figure 1.)

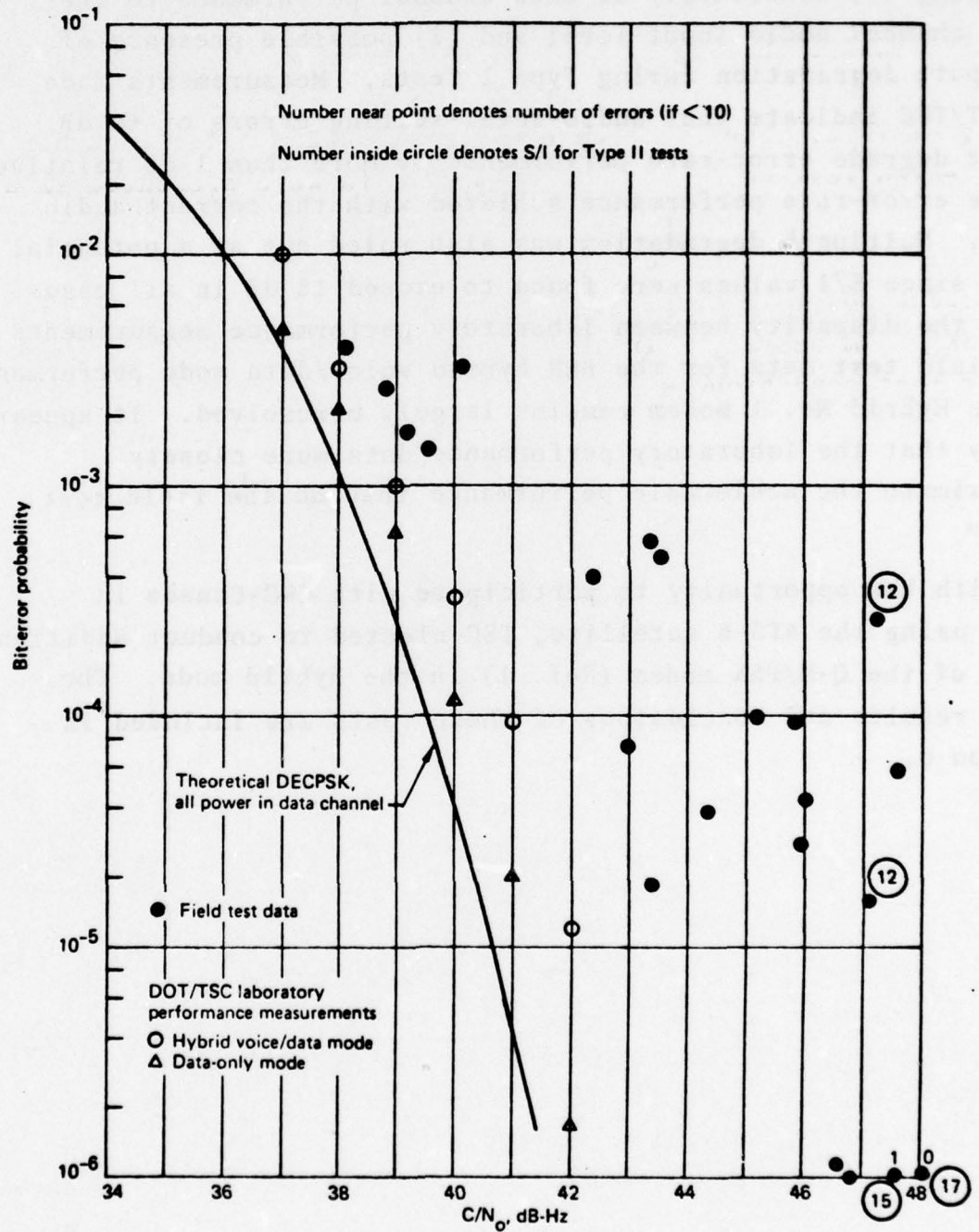

FIGURE 1. BIT-ERROR-RATE PERFORMANCE, Q-M/PSK DATA MODEM HYBRID VOICE AND DATA MODE, 1200 bps (FROM REPORT REFERENCE 2, FIGURE 23)

"In an effort to isolate the reason for the performance differences cited, several factors have been investigated including (1) sensitivity of data channel performance to the voice channel audio input level and (2) possible presence of multipath degradation during Type I tests. Measurements made by DOT/TSC indicate that audio-level-setting errors of +6 dB do not degrade error-rate performance by more than 1 dB relative to the error-rate performance achieved with the correct audio level. Multipath degradation was also ruled out as a potential cause since S/I values were found to exceed 18 dB in all cases. Hence the disparity between laboratory performance measurements and field test data for the BER hybrid voice/data mode performance of the Hybrid No. 1 modem remains largely unresolved. It appears likely that the laboratory performance data more closely approximate the achievable performance than do the field test data."

With the opportunity to participate with CRC-Canada in tests using the ATS-6 satellite, TSC elected to conduct additional tests of the Q-M/PSK modem (Ref. 1) in the hybrid mode. The final results and conclusions of these tests are included in Section 6.

3. SYSTEM DESCRIPTION

3.1 GROUND STATION

The ground station was located at the CRC facility in Ottawa, Canada. Four signals were generated simultaneously: (1) the 70 MHz output of the TSC Q-M/PSK modem; (2) a 70.75 MHz CW signal sent to lock the aircraft receiver; (3) the 69.275 MHz signal of the CRC data modem; (4) FM carrier at 70.625 MHz for voice administration purposes (see Figure 2). All signals were balanced at the ground station for equal power output. These signals were then summed and mixed up to 1650 MHz where, after band pass filtering, they were amplified up to 60 watts for transmission to the satellite. The antenna was a parabolic type 28 foot dish with approximately 40 dB of gain.

3.2 AIRBORNE EQUIPMENT

The signals were received on one of the aircraft antennas, as shown on the block diagram of the communications airborne equipment, Figure 3. Measured gain plots derived from previous flight test programs are included in Figures 4 and 5. After the signals passed through the diplexer, 30 dB coupler, an attenuator, and a preamplifier, the receiver locked to the 1550.075 MHz carrier and down-converted the signals to 10 MHz where they were mixed to the original ground station intermediate frequencies. The 70 MHz voice/data signal was sent to the TSC Q-M/PSK demodulator. The signals were then demodulated on the aircraft where they were recorded. The Q-M/PSK modem was operated in the hybrid mode with phonetically balanced (PB) wordlists, identical to those used on the ATS-6 tests, as the voice input (ref. 3). The received signals at the demodulator output on the aircraft were recorded on a 14 track instrumentation tape recorder. The data signal that was received by the demodulator consisted of a pseudo-noise (PN) sequence 2047

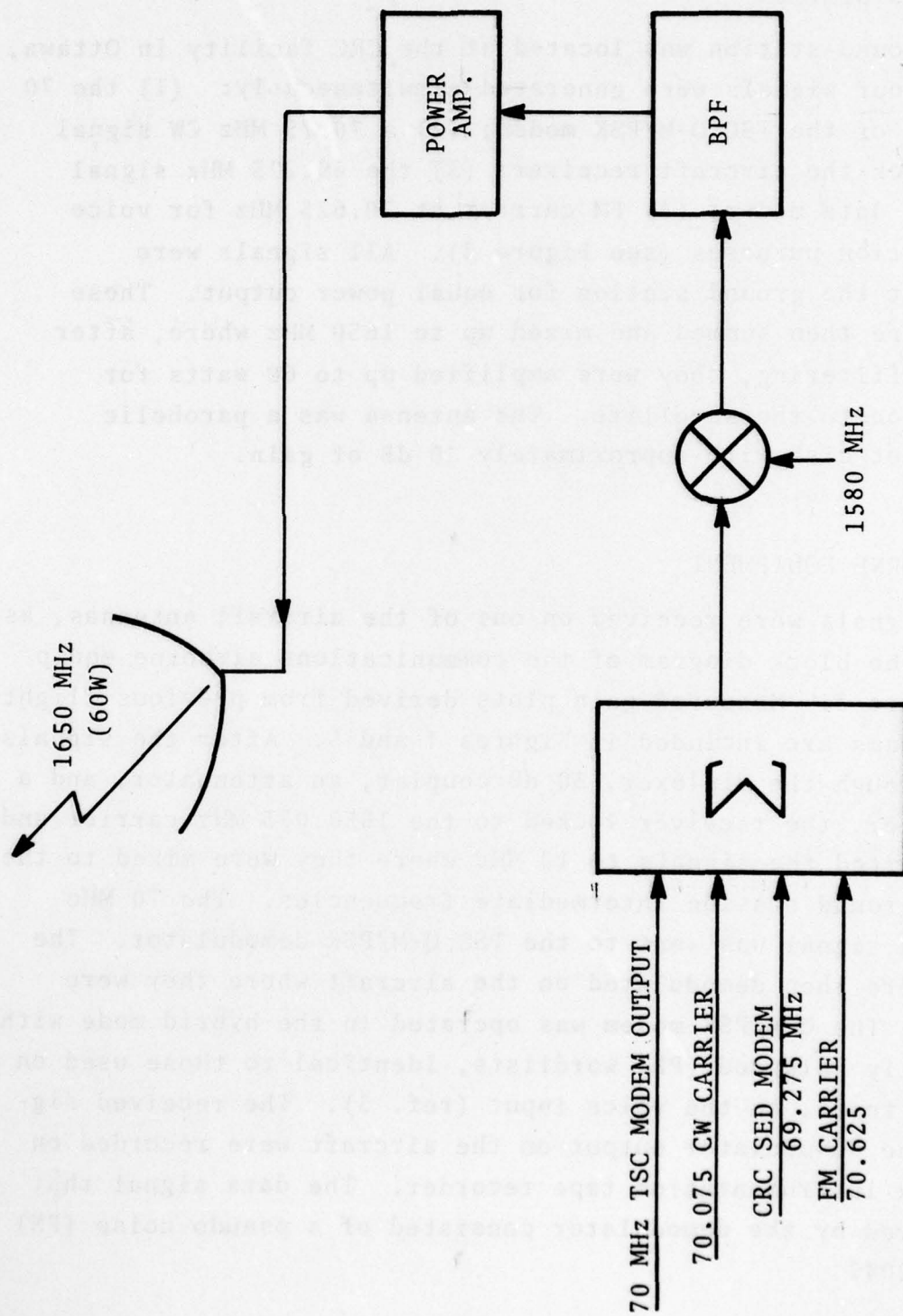

FIGURE 2. BLOCK DIAGRAM - GROUND STATION CONFIGURATION

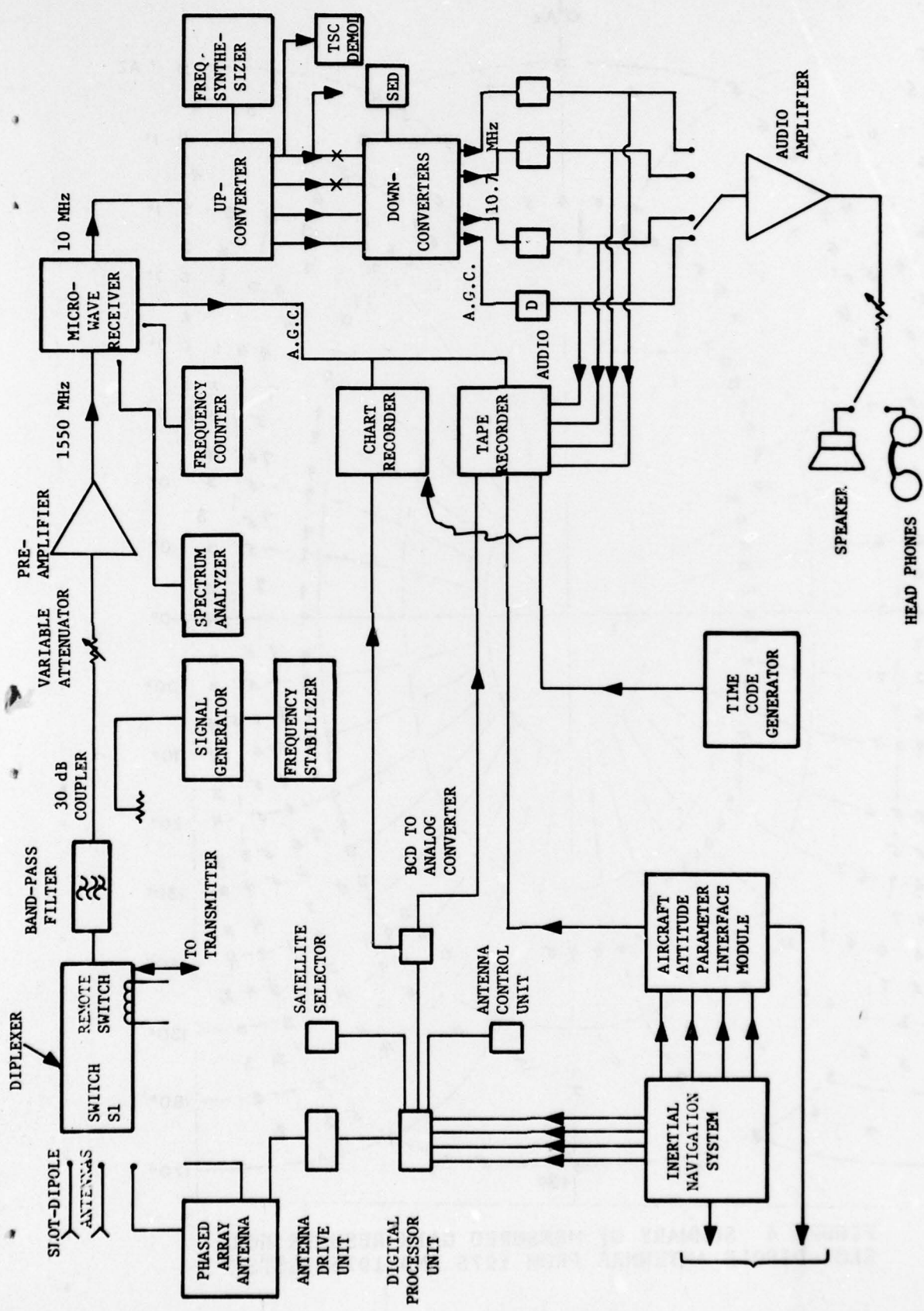

FIGURE 3. BLOCK DIAGRAM OF AIRBORNE EQUIPMENT

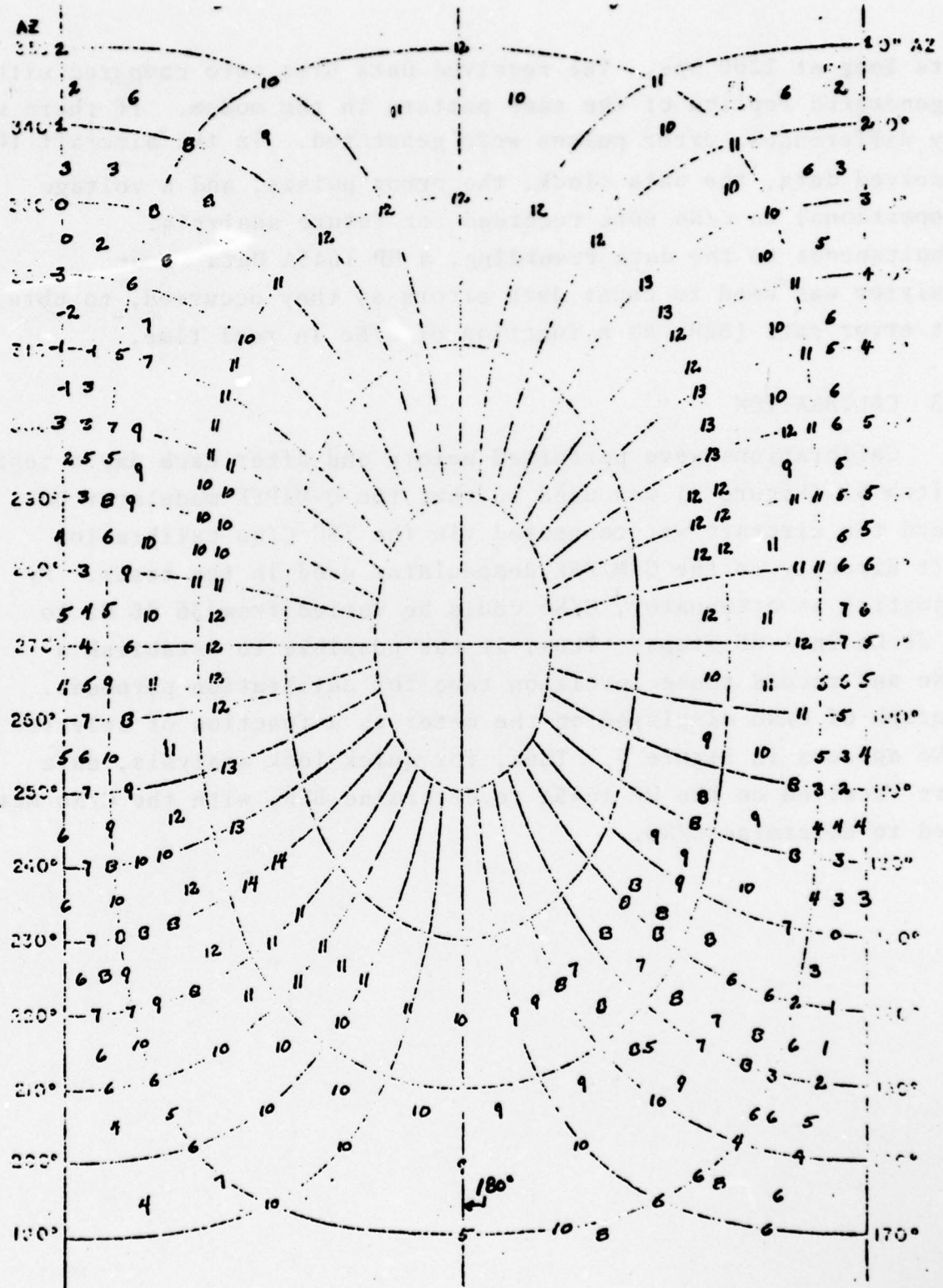

FIGURE 5 SUMMARY OF MEASURED GAIN RESULTS FOR PHASED ARRAY ANTENNA FROM 1975 AND 1976 TESTS

bits long at 1200 bps. The received data bits were compared with a generated replica of the same pattern in the modem. If there were any differences, error pulses were generated. In the aircraft the received data, the data clock, the error pulses, and a voltage proportional to C/No were recorded for future analysis. Simultaneous to the data recording, a HP 1645A Data Error Analyzer was used to count data errors as they occurred, to obtain bit error rate (BER) as a function of C/No in real time.

3.3 CALIBRATION

Calibrations were performed before and after each day's test. Switch S1 (Figure 6) was used so that the Q-M/PSK modulator on board the aircraft was connected via the TSC C/No calibration unit directly to the Q-M/PSK demodulator used in the tests. By adjusting an attenuator, C/No could be varied from 36 dB Hz to 60 dB Hz in 1 dB steps. Thus, it was possible to establish a C/No and record these levels on tape for calibration purposes. A graph of C/No displayed on the meter as a function of selected C/No appears in Figure 7. Thus, for quick look analysis, data were received on the HP 1645A to determine BER, with the C/No meter used to determine C/No.

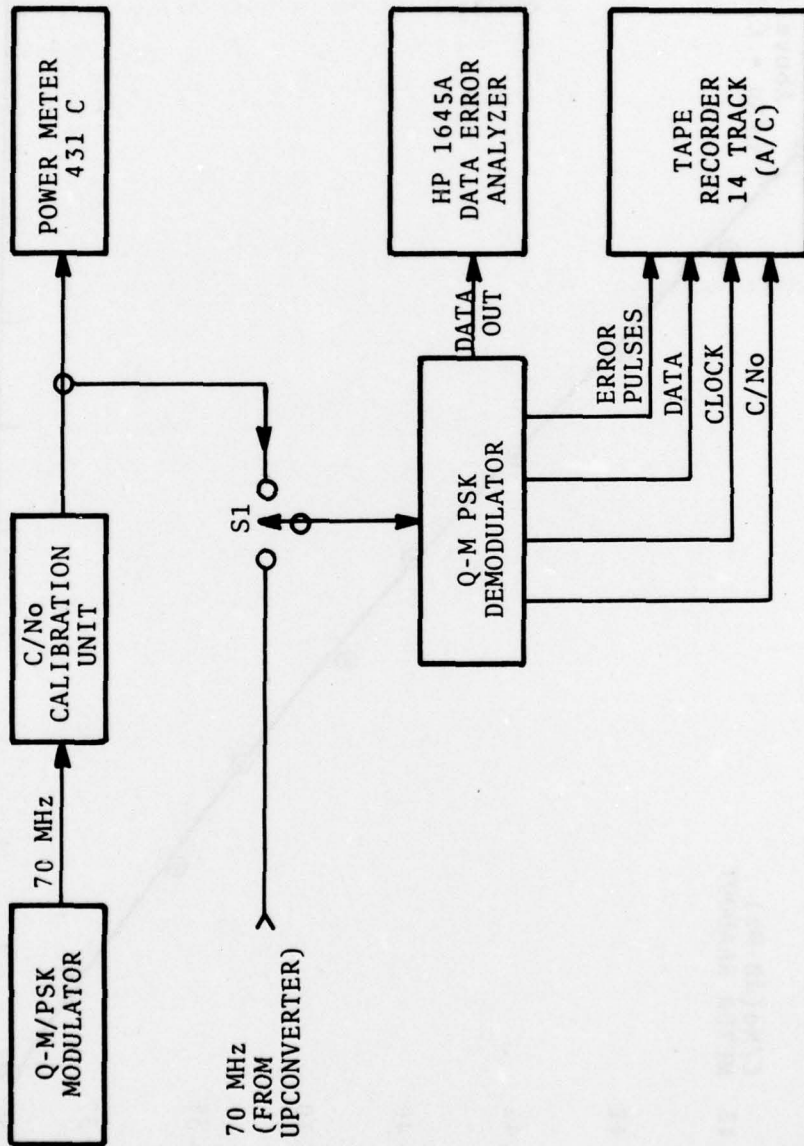

FIGURE 6. BLOCK DIAGRAM - CALIBRATION SET-UP

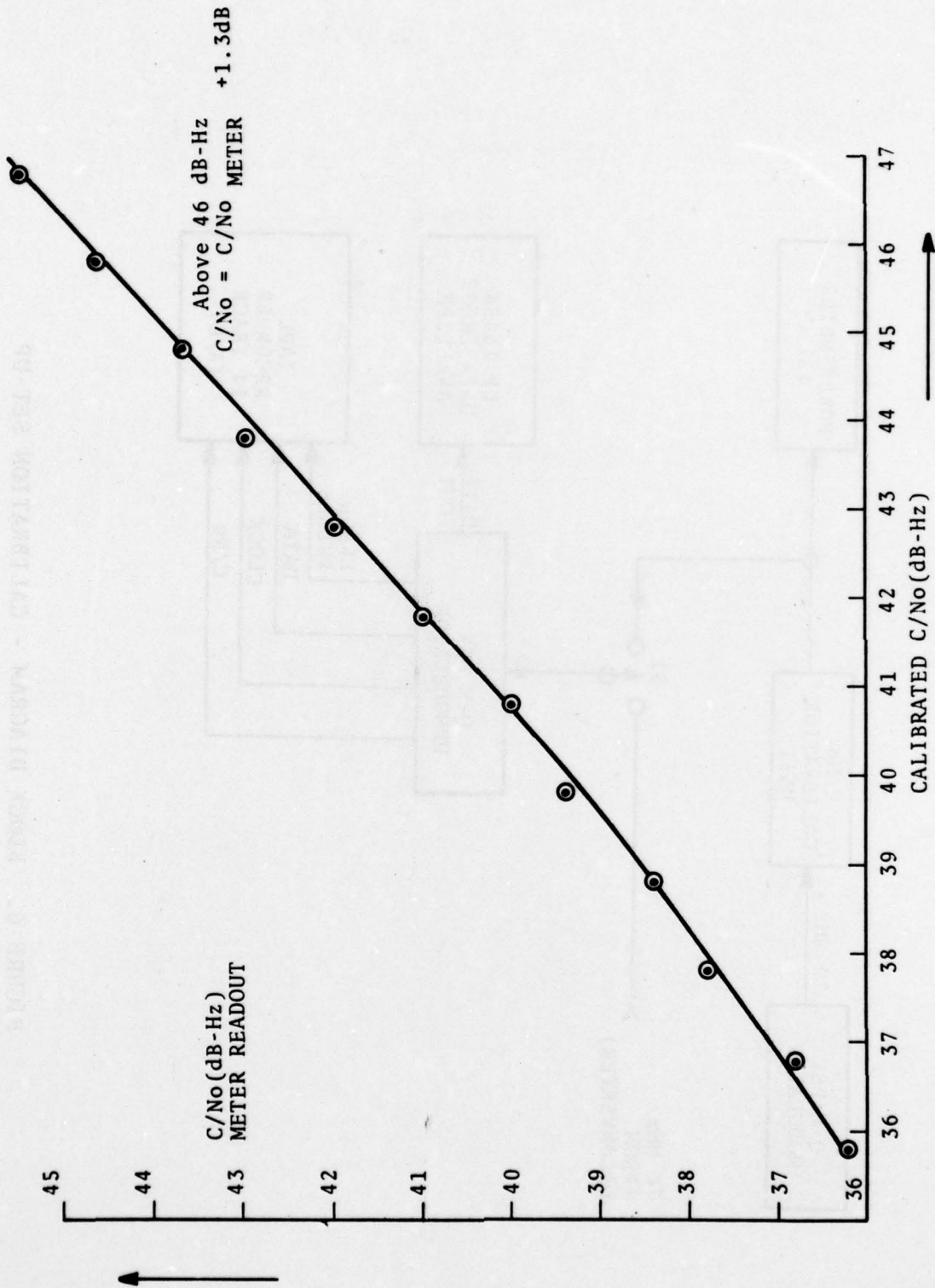

FIGURE 7 C/No METER READOUT VS. CALIBRATED C/No Q-M/PSK MODEM

4. TEST DESCRIPTION

4.1 TEST REQUIREMENTS

The general test requirements were as follows:

1. Modem: Q-M/PSK (developed by Bell Aerospace)¹
2. Test Mode: Hybrid (simultaneous voice and data)
3. Test Data: 1200 bps PN sequence, 2047 bits in length
4. Antennas: Slot dipole and phased array
5. Terrain Conditions: Bush, frozen water, and ocean
6. C/No: 38 to 47 dB-Hz
7. Data Recorded:
 - a. Digital Data
 - b. Clock
 - c. Time
 - d. Error Pulses
 - e. C/No.

4.2 SYSTEM INTEGRATION TESTS

Prior to the actual flight tests, the TSC Q-M/PSK modem equipment was delivered to CRC, Ottawa, for laboratory based system integration tests. In these tests, the airborne modem equipment was installed into aircraft racks and operated in conjunction with the Canadian airborne equipments. Operational and calibration tests were successfully conducted from 28 February to 4 March 1977. After these tests were completed, the equipment racks were installed in the Jetstar test bed aircraft.

4.3 FLIGHT TESTS

The actual tests, using the ATS-6 satellite, were conducted from 14 to 24 March 1977, with signals transmitted through the ATS-6 satellite from a ground station at Ottawa to the Canadian Jetstar aircraft operating out of three different locations. The first location selected was northwest of Ottawa, Canada, at an elevation angle to the satellite of 9° , flying over forested and snow-covered terrain with many frozen swamps and lakes. The second location selected was over Hudson's Bay east of Churchill, Manitoba, Canada resulting in a satellite elevation angle of 9° . The third area selected was Bermuda, 5° elevation angle, and over open water. Signals were transmitted from the CRC ground station at Ottawa at L-band (1650 MHz) to ATS-6 where they were received and retransmitted to the aircraft at 1550 MHz.

5. TEST RESULTS

Test conditions and results that are unique to each test are included separately in the following sections.

5.1 OTTAWA, CANADA

TEST DATE: March 14, 1977

Flight Leg	Duration (Minutes)	C/NO dB-Hz	Antenna Used	Tx Voice On/Off	Bit Error Rate
#1	15	37.5	L. Slot Dipole	off	10^{-2}
#1	15	38	L. Slot Dipole	on	1.6×10^{-2}
#1	15	39	L. Slot Dipole	on	6.8×10^{-3}
#1	15	40	L. Slot Dipole	on	2.2×10^{-3}
#2	15	40	R. Slot Dipole	off	1.1×10^{-3}
#2	15	41	R. Slot Dipole	on	4.7×10^{-4}
#2	30	42	R. Slot Dipole	on	4.7×10^{-5}
#2	10	45	R. Slot Dipole	on	5.0×10^{-6}
#3	30	43	L. Slot Dipole	on	5.4×10^{-6}
#3	6	44	L. Slot Dipole	on	$< 10^{-6}$
#4	60	46	Phased Array	on	$< 10^{-6}$

TEST DATE: March 15, 1977

Flight Leg	Duration (Minutes)	C/No dB-Hz	Antenna Used	Tx Voice On/Off	Bit Error Rate
#1	15	39.4	Phased Array	on	5.2×10^{-4}
#1	15	39.7	Phased Array	off	2.9×10^{-4}
#1	15	40.5	Phased Array	on	2.3×10^{-4}
#1	15	41.5	Phased Array	on	8.1×10^{-5}
#2	30	42.7	Phased Array	on	5.9×10^{-6}
#2	30	44	Phased Array	on	$< 10^{-6}$
#3	30	45	Phased Array	on	$< 10^{-6}$
#3	30	45	Phased Array	off	$< 10^{-6}$

The results of the Ottawa area flight test are presented in Figure 8 showing the probability of bit error (P_e) vs. C/No (dB-Hz).

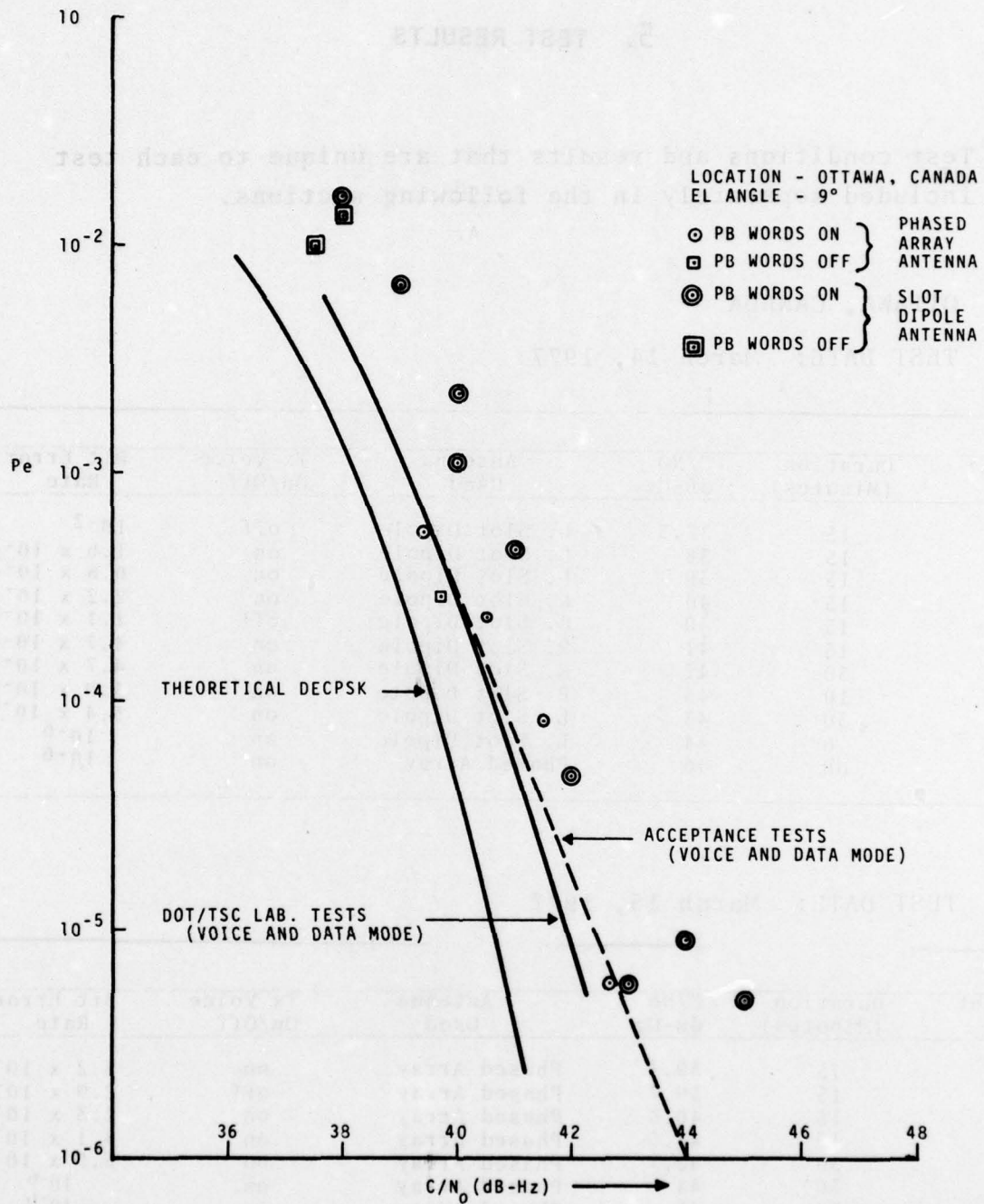

FIGURE 8 PROBABILITY OF BIT ERROR VS CARRIER TO NOISE DENSITY RATIO FOR DECPSK MODEM (VOICE AND DATA MODE, AT 1200 BPS) -- OTTAWA CANADA

5.2 CHURCHILL, MANITOBA

TEST DATE: March 18, 1977

Flight Leg.	Duration (Minutes)	C/No dB-Hz	Antenna Used	Tx Voice On/Off	Bit Error Rate
#1	15	37.7	Phased Array	off	6.8×10^{-3}
#1	15	38	Phased Array	on	1.1×10^{-2}
#1	15	38.3	Phased Array	on	7.7×10^{-3}
#1	10	39.3	Phased Array	on	1.1×10^{-3}
#2	25	41.0	Phased Array	on	2.4×10^{-4}
#2	15	41.0	Phased Array	on	1.1×10^{-4}
#2	4	41.5	L. Slot Dipole	on	5.7×10^{-4}
#2	6	42.5	Phased Array	on	1.3×10^{-5}

TEST DATE: March 19, 1977

TEST TIME: 2 hours

Flight Leg.	Duration (Minutes)	C/No dB-Hz	Antenna Used	Tx Voice On/Off	Bit Error Rate
#1	20	42.5	Phased Array	on	2.4×10^{-5}
#1	20	43.0	Phased Array	off	2.9×10^{-5}
#2	6	44.8	L. Slot Dipole	on	1.1×10^{-4}
#2	20	47	L. Slot Dipole	on	8.6×10^{-6}

The results of the Churchill flight tests are presented in Figure 9 as Pe vs. C/No.

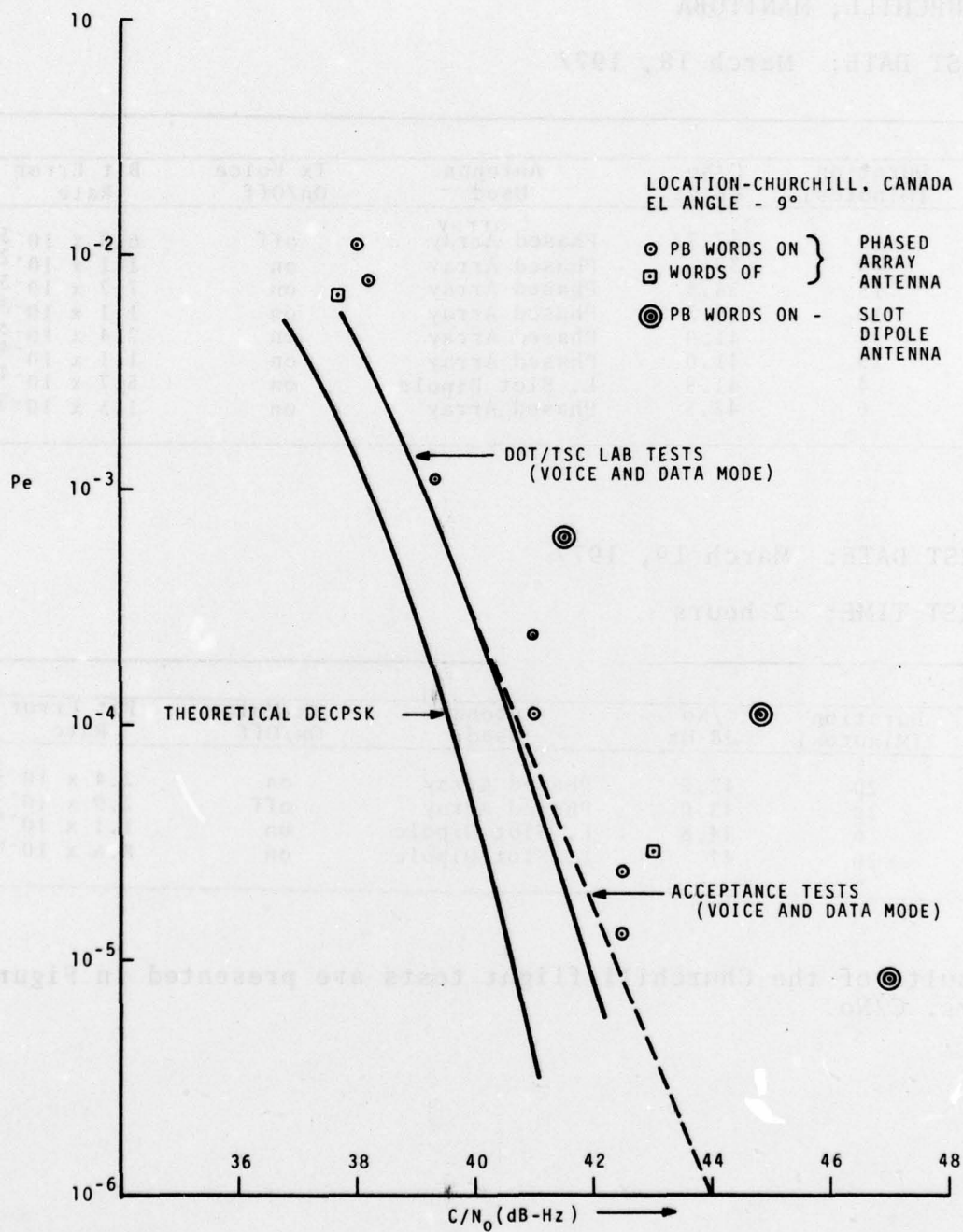

FIGURE 9 PROBABILITY OF BIT ERROR VS CARRIER TO NOISE DENSITY RATIO FOR DECPSK MODEM (VOICE AND DATA MODE, AT 1200 BPS) -- CHURCHILL MANITOBA

5.3 BERMUDA (ATLANTIC OCEAN)

TEST DATE: March 23, 1977

Flight Leg.	Duration (Minutes)	C/No dB-Hz	Antenna Used	Tx Voice On/Off	Bit Error Rate
#1	3	38.2	Phased Array	off	6.7×10^{-3}
#1	4	39	Phased Array	off	1.4×10^{-3}
#1	4	40	Phased Array	off	9.5×10^{-4}
#1	6	41	Phased Array	off	1.8×10^{-4}
#1	5	41.6	Phased Array	off	6.1×10^{-5}
#2	3	38.0	Phased Array	on	2.4×10^{-2}
#2	4	39.0	Phased Array	on	3.0×10^{-3}
#2	4	39.7	Phased Array	on	2.4×10^{-3}
#2	14	40.8	Phased Array	on	4.6×10^{-4}
#2	7	41.0	Phased Array	on	6.3×10^{-4}
#2	5	42.0	Phased Array	on	1.6×10^{-4}
#2	14	43.0	Phased Array	on	4.0×10^{-5}

The results of the Bermuda flight tests are presented in Figure 10 as P_e vs. C/No.

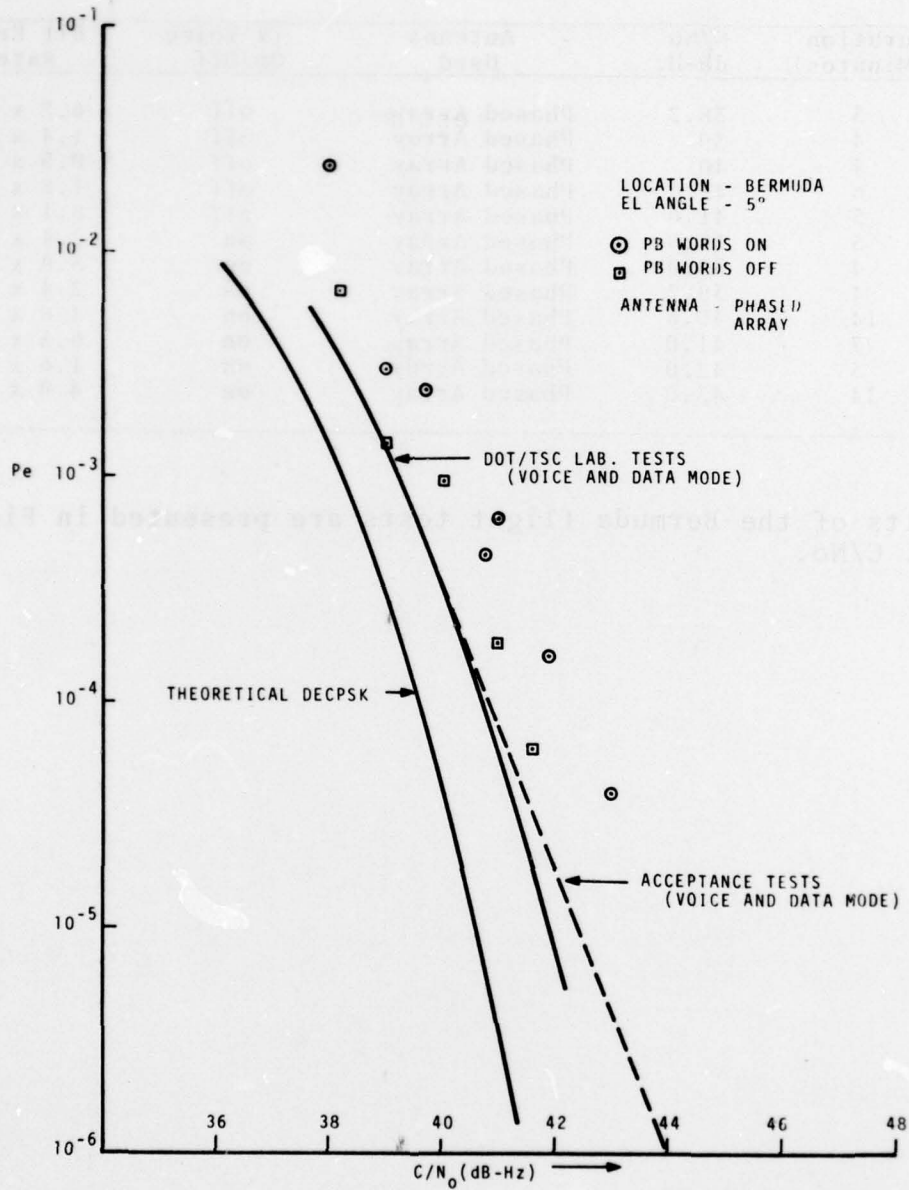

FIGURE 10 PROBABILITY OF BIT ERROR VS CARRIER TO NOISE DENSITY RATIO FOR DECPSK MODEM (VOICE AND DATA MODE, AT 1200 BPS) -- BERMUDA

6. SUMMARY AND CONCLUSIONS

The completion of the tests resulted in 44 test points with a total accumulated data time of 10 hours and 40 minutes, derived from the three different test areas. The Q-M/PSK modem, both ground-based and airborne, performed well without breakdown, with only a minimum of maintenance required. Full support and cooperation were provided by CRC for the ground station operation and the equipment interfacing and data gathering instrumentation within the Canadian Jetstar test aircraft. Also, full support was obtained from NASA for the scheduling and availability of the ATS-6 satellite. The ATS-6 satellite performed without loss or degradation of signal and with essentially no loss of test time.

Analysis of the acquired real time data has been completed and shows that the performance of the Q-M/PSK modem, in the voice and data mode, compared closely with the acceptance test data (Ref. 1) and the DOT/TSC laboratory test data (Ref. 4).

In comparing the results with and without PB words being simultaneously transmitted over the same channel, the data curves show no significant difference in the performance of the Q-M/PSK modem.

From evaluation of the results of the post-flight analyses of the slot dipole data (Ref. Figure 9), the conclusion is that the behavior of the slot dipole data is due to multipath.

In the graph it is seen that the three data points that comprise the curve representing the slot dipole data are greatly removed from not only the theoretical DECPSK curve but also the curves representing the phased array data. At the point at which $P_e = 10^{-5}$ the slot dipole curve is 7dB from theoretical and approximately 4.5dB from the phased array curve. Analysis of the

C/No voltage recorded on tape during the flight tests verifies the accuracies of these three points. The 47.5 dB Hz point varies ± 1 dB most of the time and has no greater variation than ± 2 dB. The two data points at 41.5 dB Hz and 44.8 dB Hz show the same type of variation, ± 1 dB most of the time, with an occasional variation in C/No of ± 2 dB. At no time were any catastrophic fades observed.

Finally, when the data on the three curves are compared with the data from ATS-6, shown in Figure 1, the results disagree by 2-3 dB. It is concluded that the previous flight tests of the Q-M/PSK modem (voice and data mode) using ATS-6 are invalid due to an unknown procedural or implementation error or equipment malfunction.

REFERENCES

1. "Q-M/PSK Voice/Data Modem," Bell Aerospace Corp., Report No. FAA-RD-76-63, March 1976.
2. "Air Traffic Control Experimentation and Evaluation with NASA ATS-6 Satellite," Report No. FAA-RD-75-173-1, May 1977.
3. P. Milner and J.S. Golab, "Intelligibility of Voice Transmissions Through a Satellite Relay System," 89th Meeting, Acoustical Society of America, S23, 1975.
4. C. Duncombe, "Results of AEROSAT Channel Simulation Tests, Q-M/PSK Voice/Data Modem, TSC Ranging Modem," Report No. FAA-RD-76-103, July 1976.