

AD-A053 206

BENDIX CORP FORT LAUDERDALE FL AVIONICS DIV  
VERY-HIGH-FREQUENCY AEROSAT AIRBORNE TERMINAL.(U)  
DEC 77 E O KIRNER, D KUNTMAN, J WILSON

F/G 22/2

DOT-TSC-1121

UNCLASSIFIED

FAA-RD-77-156

NL

1 of 2

AD  
A053206

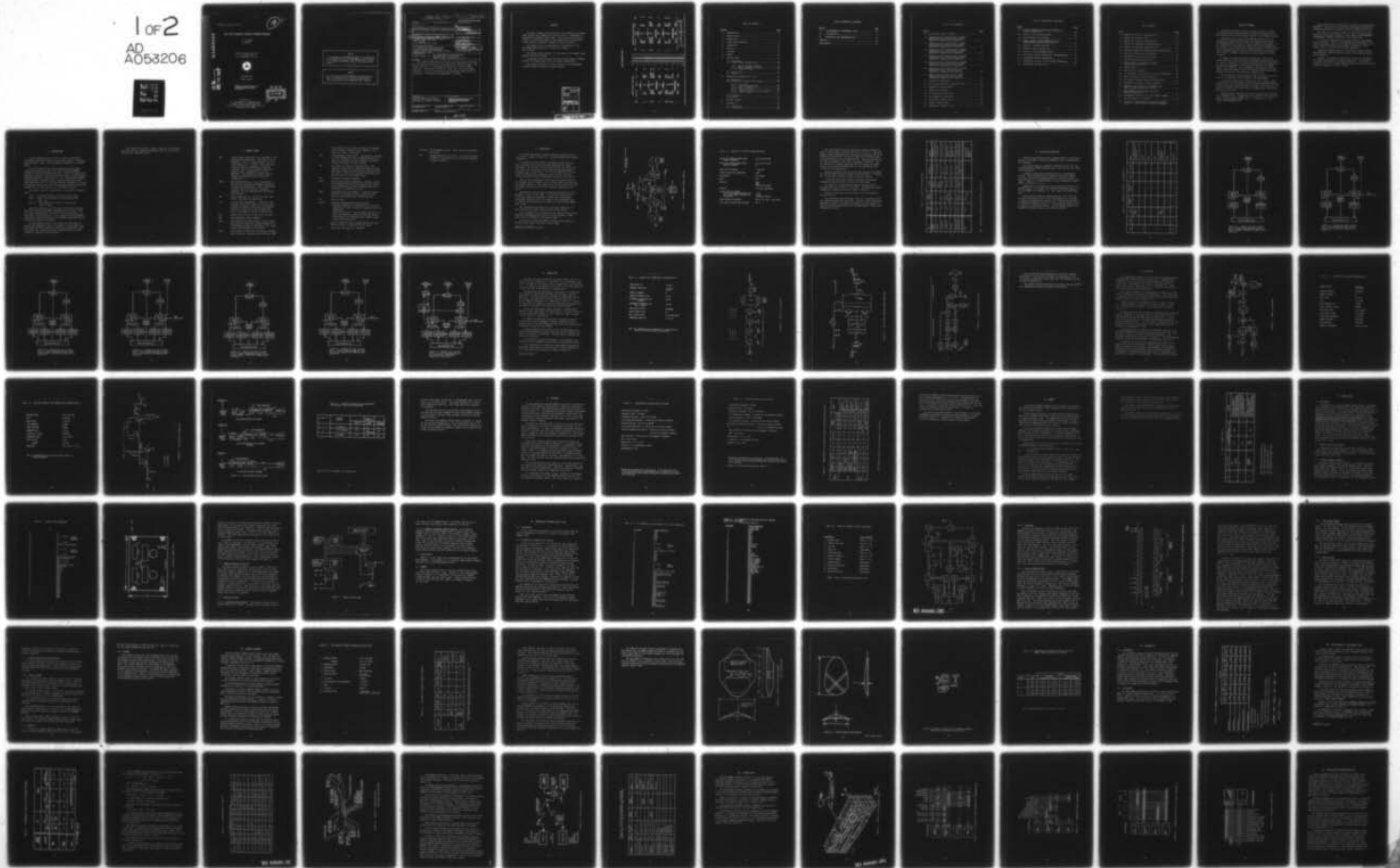

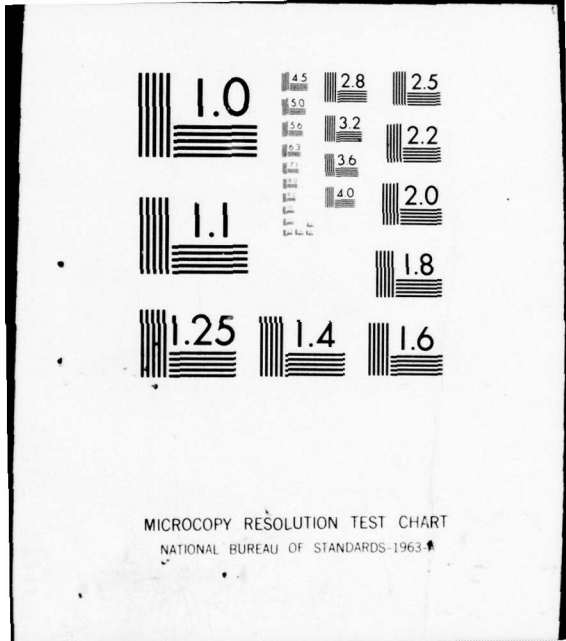

MICROCOPY RESOLUTION TEST CHART  
NATIONAL BUREAU OF STANDARDS-1963-A

REPORT NO. FAA-RD-77-156

13

AD A 053206

VERY-HIGH-FREQUENCY AEROSAT AIRBORNE TERMINAL

E. O. Kirner  
D. Kuntman  
J. Wilson

BENDIX AVIONICS DIVISION  
P.O. Box 9414  
Fort Lauderdale FL 33310



DECEMBER 1977

FINAL REPORT

DOCUMENT IS AVAILABLE TO THE U.S. PUBLIC  
THROUGH THE NATIONAL TECHNICAL  
INFORMATION SERVICE, SPRINGFIELD,  
VIRGINIA 22161

DDC  
RECEIVED  
APR 27 1978  
B

AD No. \_\_\_\_\_  
DDC FILE COPY

Prepared for  
U.S. DEPARTMENT OF TRANSPORTATION  
FEDERAL AVIATION ADMINISTRATION  
Systems Research and Development Service  
Washington DC 20591

13

VERY HIGH FREQUENCY AIRBORNE TERMINAL

NOTICE

This document is disseminated under the sponsorship of the Department of Transportation in the interest of information exchange. The United States Government assumes no liability for its contents or use thereof.

NOTICE

The United States Government does not endorse products or manufacturers. Trade or manufacturers' names appear herein solely because they are considered essential to the object of this report.

VDV02330E

DDC LIFE COPY

OM DA

RECEIVED  
APR 22 1978  
D D C

U.S. DEPARTMENT OF TRANSPORTATION  
RESEARCH AND DEVELOPMENT ADMINISTRATION  
WASHINGTON, D.C. 20590

18 FAA-RD, TSC

19 77-156, FAA-77-17

Technical Report Documentation Page

1. Report No. FAA-RD-77-156		2. Government Accession No.		3. Recipient's Catalog No.	
4. Title and Subtitle 6 VERY-HIGH-FREQUENCY AEROSAT AIRBORNE TERMINAL		5. Report Date 12 December 1977		6. Performing Organization Code 12 101e	
7. Author(s) 10 E.O. Kirner, D. Kuntman, and J. Wilson		8. Performing Organization Report No. DOT-TSC-FAA-77-17		9. Contract or Grant No. 15 DOT-TSC-1121	
9. Performing Organization Name and Address Bendix Avionics Division* P.O. Box 9414 Fort Lauderdale FL 33310		10. Work Unit No. (TRAIS) FA711/R8122		11. Type of Report and Period Covered 9 Final Report Apr 76-Mar 1977	
12. Sponsoring Agency Name and Address U.S. Department of Transportation Federal Aviation Administration Systems Research and Development Service Washington DC 20591		13. Sponsoring Agency Code		14. Sponsoring Agency Code	
15. Supplementary Notes U.S. Department of Transportation *Under contract to: Transportation Systems Center Kendall Square, Cambridge MA 02142					
16. Abstract This report summarizes the results of a study aimed at defining the airborne VHF terminal for the experimental AEROSAT program. The system consists of a 22-channel VHF transceiver for full-duplex operation. Provisions are made for voice, data, and surveillance modulation. The all-solid-state system develops a power output of 150 watts. The system noise temperature is 1136°K.					
17. Key Words VHF Transceiver, Avionics, AEROSAT, Full Duplex, Oceanic, Terrestrial, Satcom, Satellite			18. Distribution Statement DOCUMENT IS AVAILABLE TO THE U.S. PUBLIC THROUGH THE NATIONAL TECHNICAL INFORMATION SERVICE, SPRINGFIELD, VIRGINIA 22161		
19. Security Classif. (of this report) Unclassified		20. Security Classif. (of this page) Unclassified		21. No. of Pages 102	22. Price

i 410 662 TDB

## PREFACE

The study results presented in this final report were achieved under contract and technical direction of the U.S. Department of Transportation Systems Center (TSC). This project was initiated as part of a DOT/FAA program to investigate satellite-based-air-traffic-control systems for commercial oceanic aircraft.

The authors wish to acknowledge the contributions of the following Bendix engineers: D. Glace, R. Johnson, and J. Miller.

The Bendix project engineer for this Phase I VHF AEROSAT study program was Daryal Kuntman.

The guidance and technical direction of Wayne Shear of Bendix Avionics and Joseph Golab of TSC are hereby acknowledged.

This volume describes the final version of the VHF AEROSAT airborne terminal proposed by Bendix Avionics.

ACCESSION for		
NTIS	White Section	<input checked="" type="checkbox"/>
DDC	Buff Section	<input type="checkbox"/>
UNANNOUNCED		<input type="checkbox"/>
JUSTIFICATION _____		
BY _____		
DISTRIBUTION/AVAILABILITY CODES		
Dist.	AVAIL.	and/or SPECIAL
A		

METRIC CONVERSION FACTORS

Approximate Conversions to Metric Measures

Symbol	When You Know	Multiply by	To Find	Symbol
<b>LENGTH</b>				
m	inches	2.5	centimeters	cm
cm	feet	30	centimeters	cm
m	yards	0.9	meters	m
mi	miles	1.6	kilometers	km
<b>AREA</b>				
m <sup>2</sup>	square inches	6.5	square centimeters	cm <sup>2</sup>
m <sup>2</sup>	square feet	0.09	square meters	m <sup>2</sup>
m <sup>2</sup>	square yards	0.8	square meters	m <sup>2</sup>
m <sup>2</sup>	square miles	2.6	square kilometers	km <sup>2</sup>
ac	acres	0.4	hectares	ha
<b>MASS (weight)</b>				
oz	ounces	28	grams	g
lb	pounds	0.45	kilograms	kg
sh	short tons (2000 lb)	0.9	metric tons	t
<b>VOLUME</b>				
l	liters	1	liters	l
qt	quarts	0.95	liters	l
pt	pints	0.47	liters	l
gal	gallons	3.8	liters	l
cu ft	cubic feet	0.03	cubic meters	m <sup>3</sup>
cu yd	cubic yards	0.76	cubic meters	m <sup>3</sup>
<b>TEMPERATURE (exact)</b>				
F	Fahrenheit temperature	$(F - 32) \times \frac{5}{9}$	Celsius temperature	C

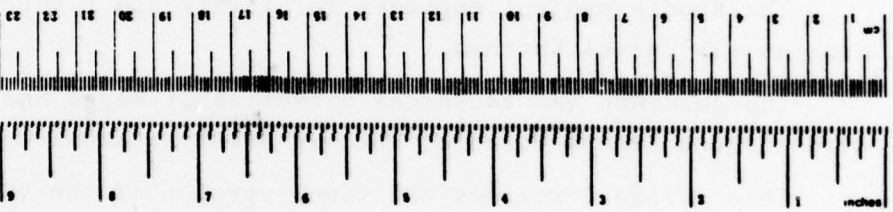

Approximate Conversions from Metric Measures

Symbol	When You Know	Multiply by	To Find	Symbol
<b>LENGTH</b>				
mm	millimeters	0.04	inches	in
cm	centimeters	0.4	inches	in
m	meters	3.3	feet	ft
km	kilometers	0.6	miles	mi
<b>AREA</b>				
m <sup>2</sup>	square centimeters	0.16	square inches	in <sup>2</sup>
m <sup>2</sup>	square meters	1.2	square yards	yd <sup>2</sup>
km <sup>2</sup>	square kilometers	0.4	square miles	mi <sup>2</sup>
ha	hectares (10,000 m <sup>2</sup> )	2.5	acres	ac
<b>MASS (weight)</b>				
g	grams	0.005	ounces	oz
kg	kilograms	2.2	pounds	lb
t	metric tons (1000 kg)	1.1	short tons	sh
<b>VOLUME</b>				
ml	milliliters	0.03	fluid ounces	fl oz
l	liters	1.06	quarts	qt
l	liters	0.26	gallons	gal
m <sup>3</sup>	cubic meters	36	cubic feet	cu ft
m <sup>3</sup>	cubic meters	1.3	cubic yards	cu yd
<b>TEMPERATURE (exact)</b>				
C	Celsius temperature	$(C \times \frac{9}{5}) + 32$	Fahrenheit temperature	F

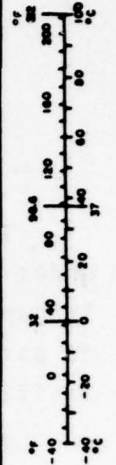

## TABLE OF CONTENTS

<u>Section</u>	<u>Page</u>
1. INTRODUCTION.....	1
2. ABBREVIATIONS.....	3
3. DESCRIPTION.....	6
4. SYSTEM CONFIGURATIONS.....	11
5. TRANSMITTER.....	20
6. RECEIVER.....	26
7. DIPLEXER.....	34
8. MODEMS.....	39
9. CONTROL PANEL.....	42
9.1 Background.....	42
9.2 Control Panel Configuration.....	42
9.2.1 Active Frequency Display.....	42
9.2.2 Manual Frequency Selection.....	45
9.2.3 Control Switches.....	45
9.3 Installation.....	47
9.4 Summary.....	47
10. TRANSCIVER INTERFACE UNIT (TIU).....	48
10.1 Background.....	48
10.2 Transmitter Interface Unit Design.....	48
10.2.1 Auto-Tune.....	53
10.2.2 Serial Frequency Data.....	53
10.2.3 Audio Input/Output.....	56
10.2.4 Press to Talk.....	56
10.2.5 Transmit and Receive Data Signals.....	57
10.2.6 Control Signal.....	57
10.3 Interface.....	57
10.4 Summary.....	58
11. AIRBORNE ANTENNAS.....	59
12. RELIABILITY.....	68
12.1 Background.....	68
12.2 Conclusion.....	68

TABLE OF CONTENTS (CONTINUED)

<u>Section</u>	<u>Page</u>
13. ELECTROMAGNETIC INTERFERENCE (EMI).....	70
14. INSTALLATION.....	78
15. CONCLUSIONS AND RECOMMENDATIONS.....	84
APPENDIX.....	86
BIBLIOGRAPHY.....	88

LIST OF ILLUSTRATIONS

<u>Figure</u>		<u>Page</u>
3.1	VHF AIRBORNE AEROSAT TERMINAL.....	7
4.1	AEROSAT VHF TEST AVIONICS TYPE I SYSTEM (CONFIGURATION #1) HALF-DUPLEX WITHOUT TERRESTRIAL COMMUNICATION CAPABILITY.....	13
4.2	AEROSAT VHF TEST AVIONICS TYPE I SYSTEM (CONFIGURATION #2) HALF-DUPLEX WITHOUT TERRESTRIAL COMMUNICATION CAPABILITY.....	14
4.3	AEROSAT VHF TEST AVIONICS TYPE II SYSTEM (CONFIGURATION #3) HALF-DUPLEX WITHOUT TERRESTRIAL COMMUNICATION CAPABILITY.....	15
4.4	AEROSAT VHF TEST AVIONICS TYPE II SYSTEM (CONFIGURATION #4) HALF-DUPLEX WITHOUT TERRESTRIAL COMMUNICATION CAPABILITY.....	16
4.5	AEROSAT VHF TEST AVIONICS TYPE II SYSTEM (CONFIGURATION #5) FULL-DUPLEX WITHOUT TERRESTRIAL COMMUNICATION CAPABILITY.....	17
4.6	AEROSAT VHF TEST AVIONICS TYPE II SYSTEM (CONFIGURATION #6) FULL-DUPLEX WITH TERRESTRIAL COMMUNICATION CAPABILITY.....	18
4.7	AEROSAT TEST AVIONICS TYPE III SYSTEM (CONFIGURATION #7) FULL-DUPLEX WITH TERRESTRIAL COMMUNICATION CAPABILITY.....	19
5.1	AEROSAT VHF TRANSMITTER.....	22
5.2	VHF 150-WATT PUSH-PULL POWER AMPLIFIER.....	23
5.3	TRANSMITTER MODIFICATIONS.....	24
6.1	AEROSAT VHF RECEIVER.....	27
6.2	VHF LOW-NOISE PREAMPLIFIER.....	30
6.3	VHF PREAMPLIFIER LOCATIONS.....	31
9.1	VHF AEROSAT CONTROL PANEL.....	44
9.2	AEROSAT CONTROL PANEL.....	46
10.1	TRANSCEIVER INTERFACE UNIT.....	52

LIST OF ILLUSTRATIONS (CONTINUED)

<u>Figure</u>		<u>Page</u>
10.2	TIMING DIAGRAM FOR SERIAL DATA TRANSFER OF CONTROL FREQUENCIES.....	54
11.1	BOEING 747 SLOT DIPOLE ANTENNA.....	64
11.2	BOEING CROSSED LOOP ANTENNA.....	65
11.3	DORNE & MARGOLIN VHF AIRBORNE SATELLITE COMMUNICATIONS ANTENNA TYPE DMC 33-2.....	66
13.1	BOEING 747 ANTENNA LOCATIONS.....	74
13.2	POTENTIAL INTRA-AIRCRAFT EMI.....	76
14.1	BOEING 747 MAIN EQUIPMENT CENTER.....	79
14.2	VHF AEROSAT WITHOUT TERRESTRIAL INTERCONNECTIONS.....	80
14.3	INTERWIRING WITHOUT TERRESTRIAL.....	81
14.4	INTERWIRING FOR TWO OF FIVE WITHOUT TERRESTRIAL.....	82
14.5	INTERWIRING FOR DMS TO TIU.....	83

## LIST OF TABLES

<u>Table</u>	<u>Page</u>
3.1 AEROSAT VHF AVIONICS CHARACTERISTICS.....	8
3.2 AEROSAT VHF AVIONICS UNITS.....	10
4.1 AEROSAT VHF AVIONICS CONFIGURATIONS.....	12
5.1 AEROSAT VHF TRANSMITTER CHARACTERISTICS.....	21
6.1 AEROSAT VHF RECEIVER CHARACTERISTICS.....	28
6.2 LOW-NOISE AEROSAT VHF PREAMPLIFIER CHARACTERISTICS.....	29
6.3 EFFECTIVE SYSTEM NOISE TEMPERATURES.....	32
7.1 PRELIMINARY DIPLEXER SPECIFICATIONS.....	35
7.2 REVISED DIPLEXER SPECIFICATIONS.....	36
7.3 VENDOR REPLIES TO REVISED VHF AEROSAT DIPLEXER SPECIFICATIONS.....	37
8.1 MODEMS TESTED.....	41
9.1 CONTROL PANEL CONNECTOR.....	43
10.1 TIU CONNECTOR PIN DESIGNATION PT1A (TOP) CONNECTOR.....	49
10.2 DMS/TIU INTERFACE SIGNAL POLARITIES.....	51
11.1 VHF AEROSAT AIRCRAFT ANTENNA SPECIFICATIONS.....	60
11.2 AVIALABLE VHF AEROSAT AIRCRAFT ANTENNAS.....	61
11.3 COMPARISON OF BOEING 747 SLOT DIPOLE WITH DORNE & MARGOLIN TURNSTILE ANTENNA.....	67
12.1 MTBF NUMBERS OF VHF AEROSAT UNITS FOR VARIOUS ENVIRONMENTS.....	69
13.1 INTERFERENCE LEVELS OF BELL AND MAGNAVOX MODEMS.....	71
13.2 EXISTING BOEING 747 AVIONICS.....	73
13.3 POTENTIAL ELECTROMAGNETIC INTERFERENCE BETWEEN BOEING 747 AVIONICS AND VHF AEROSAT EQUIPMENT.....	77

## EXECUTIVE SUMMARY

The general objective of this one-year study was to assist the Federal Aviation Administration's effort to define the hardware required for the VHF airborne terminal of the AEROSAT program.

During the initial study period Bendix Avionics first investigated the feasibility of converting existing 1965 vintage VHF SATCOM prototype avionics to the new AEROSAT requirements. It was subsequently determined that modern airborne BHF transceivers, as currently used for terrestrial communications by airlines, would lead to AEROSAT equipment with superior electrical performance, lower weight, increased reliability, and much higher cost effectiveness.

A number of different system configurations with various options were then investigated and the optimum combination selected; it consists essentially of two modified Bendix RTA-43A transceivers and permits simultaneous transmission and reception of AEROSAT Signals (FULL DUPLEX). This recommended configuration will have only 22 dedicated AEROSAT receive-and-transmit channels and would normally not be used for terrestrial communications.

The system will provide standard 70 MHz interface circuits in order to be compatible with government furnished MODEMS.

A low-noise preamplifier, mounted near the aircraft antenna, amplifies the low level signals received from the AEROSAT satellite. A solid-state power amplifier boosts the power output from the 25 watts, provided by the standard Bendix communications transceiver RTA-43A, to 150 watts.

Various signal conversion and control circuits are contained in an INTERFACE unit. Frequencies can be selected either manually, from a cockpit mounted CONTROL PANEL, or automatically, from a remote DATA MANAGEMENT UNIT.

The system has the capability for voice, data and surveillance modulation. The latter will provide an independent position determining capability in conjunction with two AEROSAT satellites.

The study also included a number of tasks which are closely related to the avionics hardware. These comprise ELECTROMAGNETIC INTERFERENCE, ANTENNAS, RELIABILITY, and INSTALLATION.

Two critical components have been identified in the AEROSAT avionics hardware. These are the ANTENNA and the DIPLEXER. Both have a pronounced effect on performance and therefore justify further study to determine the optimum compromise.

Additional studies should also be directed towards reducing the mechanical dimensions and the weight of the proposed experimental hardware.

Finally, interference considerations dictate the assignment of "CLEAR" VHF channels for AEROSAT experiments. In addition, operation of the VHF airborne AEROSAT terminal should be restricted in coastal regions for similar reasons.

## 1. INTRODUCTION

The VHF AEROSAT Avionics contract initially identified a three month study phase (Phase I) to precede a Phase II prototype hardware phase. Phase I was subsequently expanded to a 12-month study.

At the beginning of the study a general objective was to ultimately provide a suitable "kit" which would add AEROSAT capability to the ARINC 566 Transceivers. The 566 transceiver had originally offered a "SATCOM" option dating back to airline experimentation with ATS3 in the late 60's, i.e., narrow band FM (NBFM), Transmit-Receive frequency offset, Low Noise Amplifiers, High Power Amplifiers, etc. As the detailed study progressed it became increasingly obvious that the "Kit" approach would not provide user hardware that met the objectives of the AEROSAT program.

The contract required investigation of three basic configurations:

- Type I - Half-Duplex without surveillance mode (VHF),
- Type II - Half- or Full-Duplex with surveillance mode (VHF), and
- Type III - Full Duplex with L-Band to VHF converter (VHF & L-Band).

During the course of the investigation technical considerations and customer requirements suggested that the Type II with full duplex capability was the desired final configuration. In the course of the definition, it was recognized that the AEROSAT transceiver should be dedicated to the AEROSAT experiment and the "terrestrial" mode was eliminated.

The experimental nature of the program and the desire to provide some commonality with the companion L-Band hardware suggested that the study concentrate on this new transceiver, which incidentally had eliminated the old "SATCOM" provision in the interest of simplicity and reliability.

This summary report will attempt to identify the technical considerations and customer requirements that led to the final configuration contained herein.

## 2. ABBREVIATIONS

ADM	Adaptive Delta Modulation is an outgrowth of conventional data modulation. The output to an interrogator, $g(t)$ , is compared against the voice input signal, $f(t)$ . If $g(t)$ is less than $f(t)$ , a positive pulse is generated by the pulse modulator, and if $g(t)$ is greater than $f(t)$ a negative pulse is generated by the pulse modulator. The sequence of bipolar pulses is normally PSK modulated onto a carrier for transmission.
ARINC	Aeronautical Radio, Inc., is a corporation in which the United States scheduled airlines are the principal stockholders. Other stockholders include a variety of other air transport companies, aircraft manufacturers and foreign flag airlines.
BCD	Binary Coded Decimal - A four bit binary code used to represent a decimal digit.
CEP	Circular Error Probability. A measure of the accuracy with which a rocket or missile can be guided; the radius of the circle at a specific distance in which 50% of the reliable shots land. Also known as circle of probable error.
dBi	Antenna gain relative to that of an isotrope.
DMS	Data Management System (AEROSAT)
DPSK	Differential Phase-Shift Keying. Form of phase-shift keying in which the reference phase for a given keying interval is the phase of the signal during the preceding keying interval.
EIRP	EIRP stands for effective isotropically radiated power expressed in decibels above one Watt (dBW).

This quantity is the result of adding the radiated power in dBW to the gain of the antenna in dBi to which this power is delivered.

EMI Electromagnetic Interference. Interference, generally at radio frequencies, that is generated inside systems, as contrasted to radio frequency interference coming from sources outside a system.

ERP ERP stands for effective radiated power. This quantity is the result of adding the radiated power expressed in dBW to the gain of the antenna to which this power is delivered, expressed in decibels (dB) above the gain of a half-wave dipole.

GFE Government furnished equipment.

NBFM Narrow-band Frequency Modulation. Frequency modulation broadcasting system used primarily for two-way voice communication, having a maximum permissible deviation of 15 kiloHertz or less.

PROM Programmable Read Only Memory. A read-only memory that after being manufactured can have the data content of each memory cell altered once only.

PTT Press to Talk

QM/PSK Quadrature Modulation/Phase-Shift Keying.

- Quadrature Modulation. Modulation of two carrier components  $90^\circ$  apart in phase by separate modulating frequencies.
- Phase-Shift Keying. A form of phase modulation in which the modulating function shifts the instantaneous phase of the modulated wave between predetermined discrete values.

In this report the voice is modulated onto one component and data is modulated onto the other.

TIU Transceiver Interface Unit (AEROSAT)

T/R RELAY Transmit/Receive Relay. Relay used in half duplex operations.

VCO Voltage Controlled Oscillator. An oscillator whose frequency of oscillation can be varied by changing an applied voltage.

### 3. DESCRIPTION

The entire VHF AEROSAT airborne terminal defined during the study phase is shown in Figure 3.1. System characteristics appear in Table 3.1.

The omnidirectional antenna, installed on top of the aircraft fuselage, will provide coverage throughout the upper hemisphere. The diplexer will be installed near the antenna and will consist of two filters tuned to the receive and transmit frequency bands, respectively. This filter combination will effectively separate the transmitted signal from the received signal, thereby permitting simultaneous operation (full duplex).

The low noise preamplifier will also be installed close to the antenna, and will amplify the very weak signals received from the AEROSAT satellite. This remote location will improve receiver performance and permit the use of relatively lightweight coax cables.

Both the VHF receiver and the modified transmitter\* will be packaged in short 1/2 ATR cases. The two units will be fully solid state without moving parts. Remote and instantaneous independent selection of all 22 channels will be provided from the control panel mounted in the cockpit or from the Data Management System.

The transceiver interface unit (TIU) will contain all circuits required for signal conversion and system control.

The two MODEM's will contain the voice, data and surveillance modulation and demodulation circuits for the terminal. These units will be furnished by the customer (GFE).

The entire airborne VHF AEROSAT terminal can be remote controlled by the flight crew from a control panel.

---

\*Modified to produce 150 watts.

NOTE: Radiated power is 50 watts  
(17 dBw EIRP)

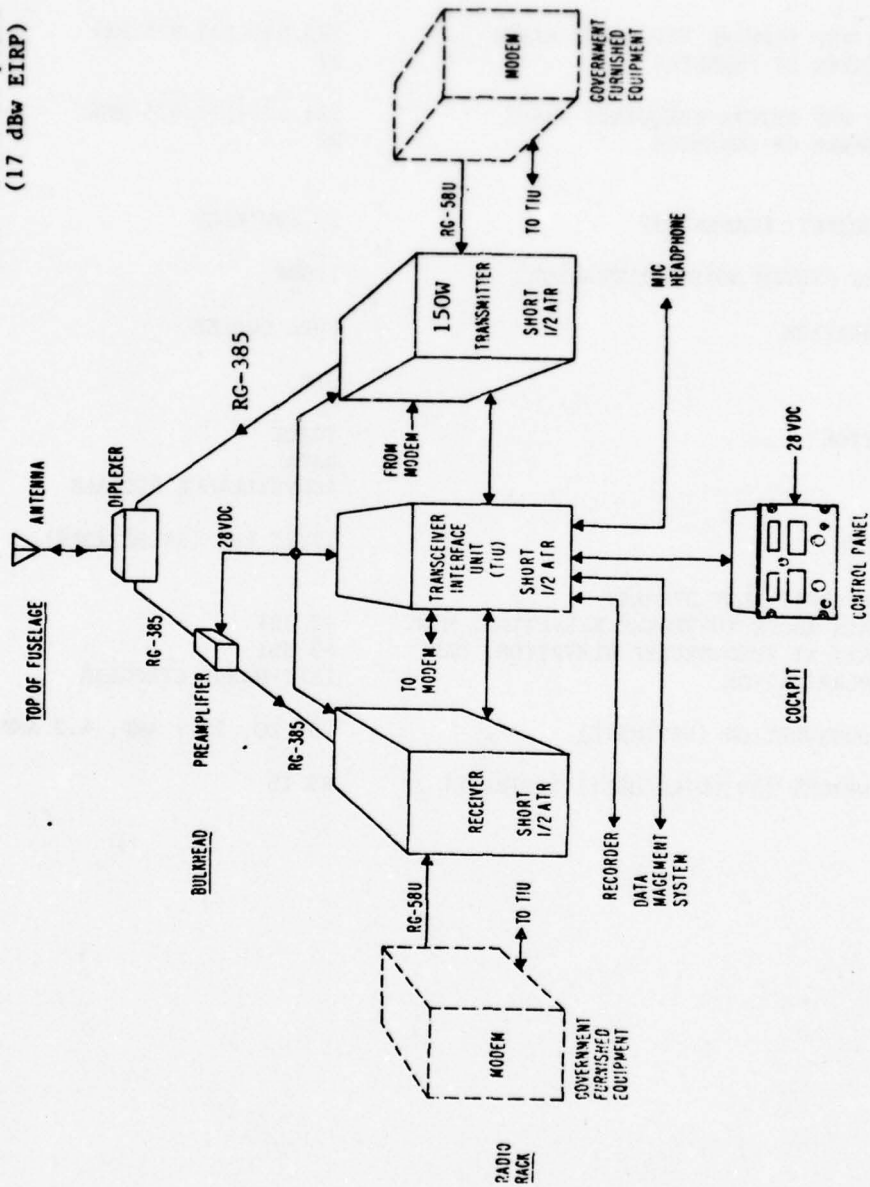

FIGURE 3.1. VHF AIRBORNE AEROSAT TERMINAL

TABLE 3.1. AEROSAT VHF AVIONICS CHARACTERISTICS

AEROSAT VHF FORWARD FREQUENCY RANGE	125.425-125.975 MHz
NUMBER OF CHANNELS	22
AEROSAT VHF RETURN FREQUENCY RANGE	131.425-131.975 MHz
NUMBER OF CHANNELS	22
POWER OUTPUT (RADIATED)	17 dBW EIRP
RECEIVER SYSTEM NOISE TEMPERATURE	1100K
CONFIGURATION	FULL DUPLEX
MODEM	GFE
MODULATION	VOICE DATA SURVEILLANCE SIGNALS
BANDWIDTH	17/25 kHz (SELECTABLE)
ANTENNA (B747 SLOT DIPOLE)	
GAIN ABOVE 10-DEGREE ELEVATION, MIN.	-2 dBi
GAIN AT ZERO-DEGREE ELEVATION, MAX.	-3 dBi
POLARIZATION	LEFT-HAND, CIRCULAR
POWER CONSUMPTION (ESTIMATE)	28V DC, 23.7 AMP, 4.2 AMP (STBY)
TOTAL WEIGHT (AVIONICS ONLY)(ESTIMATE)	69 lb

The recent deletion of the terrestrial mode has reduced the number of VHF channels required from 720 to a mere 22. Therefore, direct frequency generation with individual crystals may now be an attractive alternative to the phase-locked loop-frequency synthesizer method used in the original RTA-43A. Potential benefits are low power consumption, cost, EMI, and higher reliability. This new approach to frequency generation may facilitate the combination of the receiver and transmitter in only one RTA-43A case instead of two separate ones.

Another alternative may use the LSI VHF synthesizer designed for the new Bendix executive avionics system BX-2000. It already has a serial remote control frequency selection feature.

A trade-off study will be made to determine the optimum synthesizer approach before starting the final design.

All power for the airborne VHF AEROSAT terminal will be provided from the aircraft's 27.5V DC bus. Estimated total power consumption, weight and volume are shown in Table 3.2.

Details of each unit of the terminal will be described in Sections 4 to 10.

The following section describes various configurations which were analyzed during the study phase. The system described above eventually evolved as the optimum configuration that promises to meet the specified requirements with minimum weight, volume, power consumption and cost.

TABLE 3.2 AEROSAT VHF AVIONICS UNITS

UNIT	WEIGHT (lb)	POWER VDC/AMPS	LOCATION	DIMENSIONS	REMARKS
Antenna (B-747)	75	-	Top of Fuselage	16 x 10 feet	Boeing Slot Dipole (See Note)
Diplexer	30	-	Near Antenna	7" x 7" x 20"	Purchased item
Preamplifier	2.5	28/.5	Bulkhead	2.8" x 4.4" x 5.9"	New Bendix design
Transmitter	10.5	28/20 28/0.5 STBY	Radio Rack	Short ½ ATR	Modified Bendix RTA-43A
Receiver	10.5	28/.7	Radio Rack	Short ½ ATR	Modified Bendix RTA-43A
Interface Unit	10	28/1.5	Radio Rack	Short ½ ATR	New Bendix design
Control Head	6	28/1.0	Cockpit	4 1/8" x 5 3/8" x 4 7/8"	New Bendix design
Total	144.5	23.7 4.2 STBY			System weight critically dependent on antenna

Note: Alternative antennas are described in Section 11.

#### 4. SYSTEM CONFIGURATIONS

During the study phase of this program (Phase I), a detailed analysis of a number of different AEROSAT avionics configurations was conducted.

The initial concept of designing a modification kit for the original airborne SATCOM equipment used in the late 60's was found to be impractical.

A number of alternative configurations were subsequently studied. These provided various features such as full duplex operation; terrestrial communications with different options is shown in Table 4.1. Block diagrams of each configuration studied appear in Figures 4.1 to 4.7.

Configuration #5 (Figure 4.5) was eventually selected as the optimum choice. It provides both features considered essential for the AEROSAT test program, i.e., full duplex and surveillance mode.

The terrestrial mode was deleted because it was felt that airlines participating in the tests would probably be reluctant to remove an essential unit such as a VHF transceiver and rely on a "feasibility AEROSAT transceiver" for air-ground communications in coastal or continental regions. The VHF AEROSAT avionics was therefore dedicated strictly to satellite operation.

TABLE 4.1. AEROSAT VHF AVIONICS CONFIGURATIONS

TYPE	CONFIG.	SYSTEM	TERRESTRIAL MODE	SURVEILLANCE MODE	L-BAND	DIPLEXER	REMARKS
I	1	HALF DUPLEX					To be demonstrated with Configuration #5
	2	"	X				Deleted
II	3	"		X			Deleted
	4	"	X	X			Deleted
	5	FULL-DUPLEX		X		X	Selected final configuration
	6	"	X	X		X	Deleted
III	7	"	X	X	X	Study only	

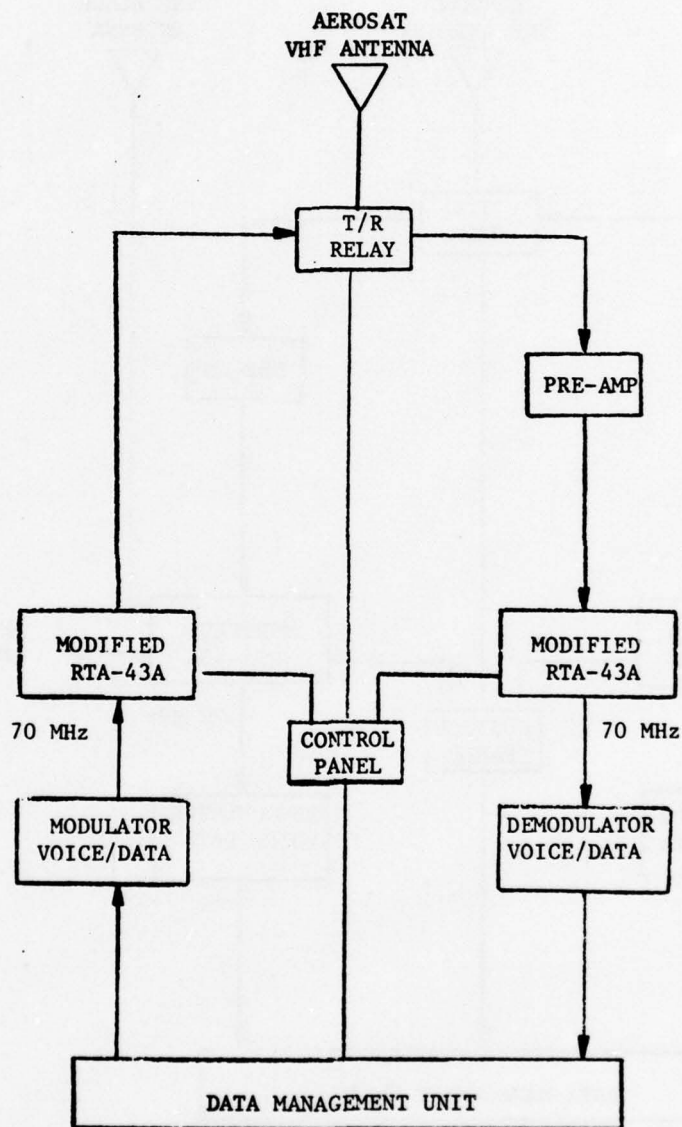

FIGURE 4.1. AEROSAT VHF TEST AVIONICS TYPE I SYSTEM (CONFIGURATION #1) HALF-DUPLEX WITHOUT TERRESTRIAL COMMUNICATION CAPABILITY

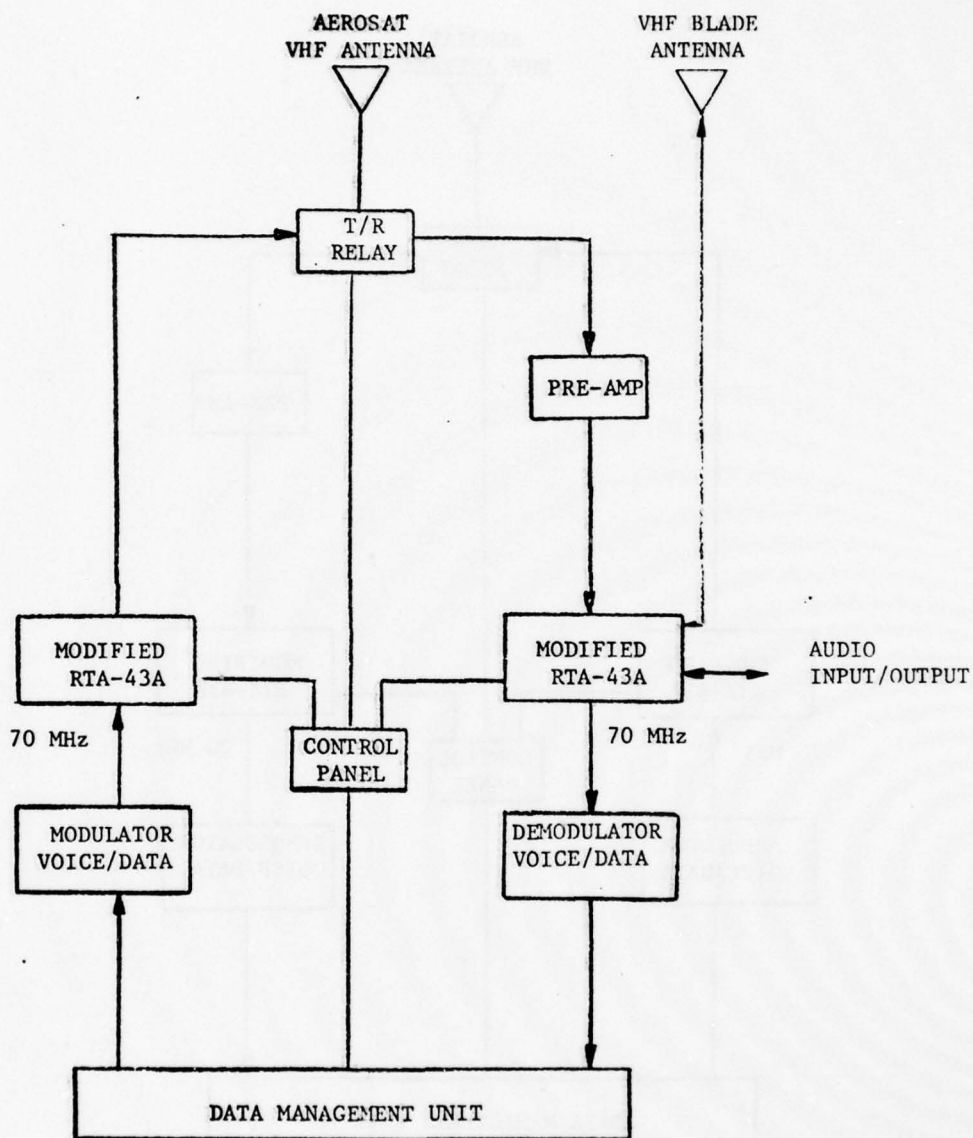

FIGURE 4.2. AEROSAT VHF TEST AVIONICS TYPE I SYSTEM (CONFIGURATION #2) HALF-DUPLEX WITH TERRESTRIAL COMMUNICATION CAPABILITY

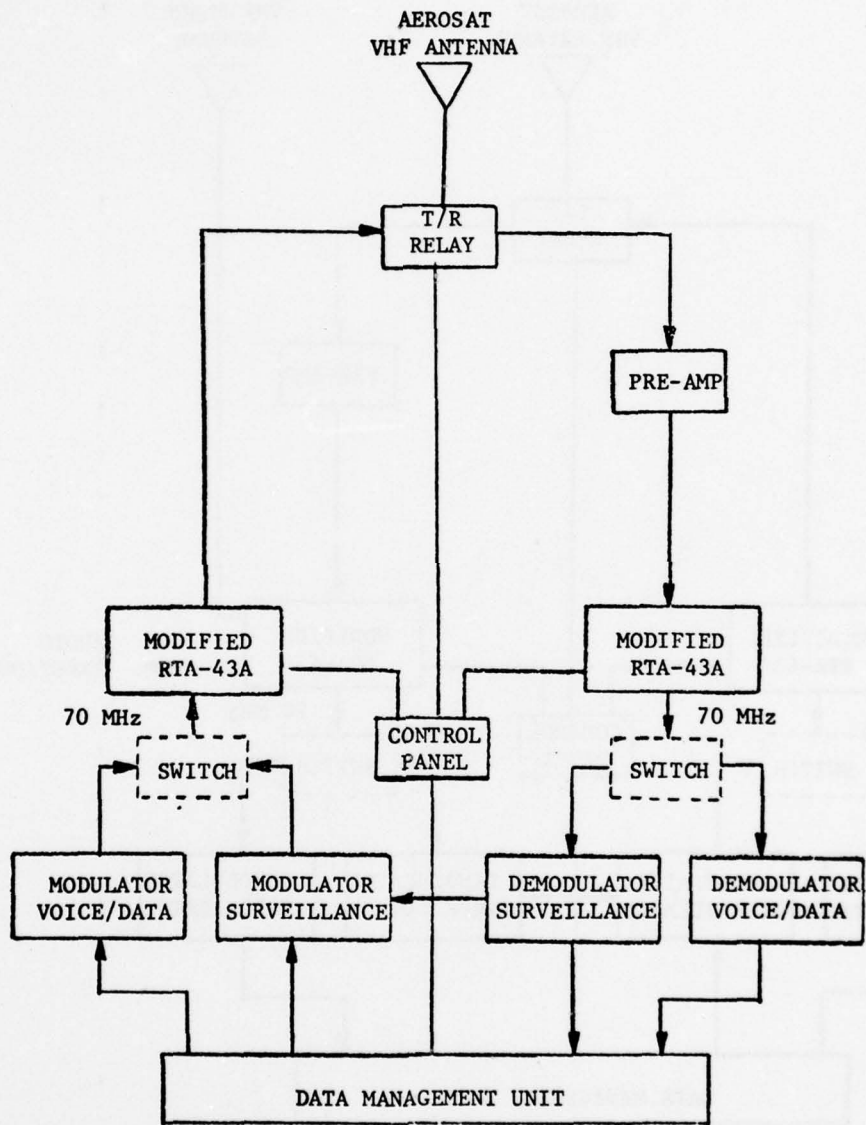

FIGURE 4.3. AEROSAT VHF TEST AVIONICS TYPE II SYSTEM (CONFIGURATION #3) HALF-DUPLEX WITHOUT TERRESTRIAL COMMUNICATION CAPABILITY

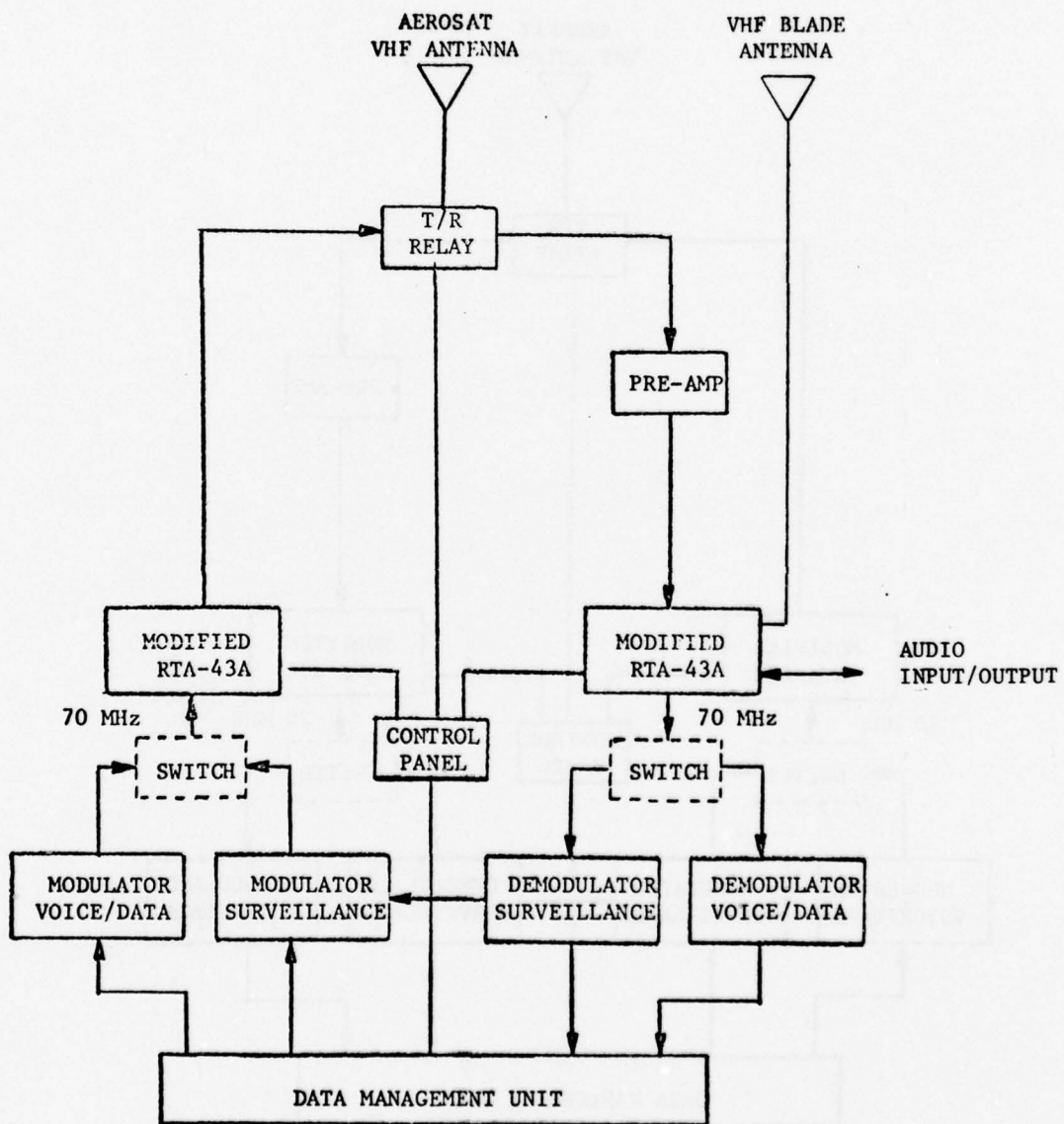

FIGURE 4.4. AEROSAT VHF TEST AVIONICS TYPE II SYSTEM (CONFIGURATION #4) HALF-DUPLEX WITH TERRESTRIAL COMMUNICATION CAPABILITY

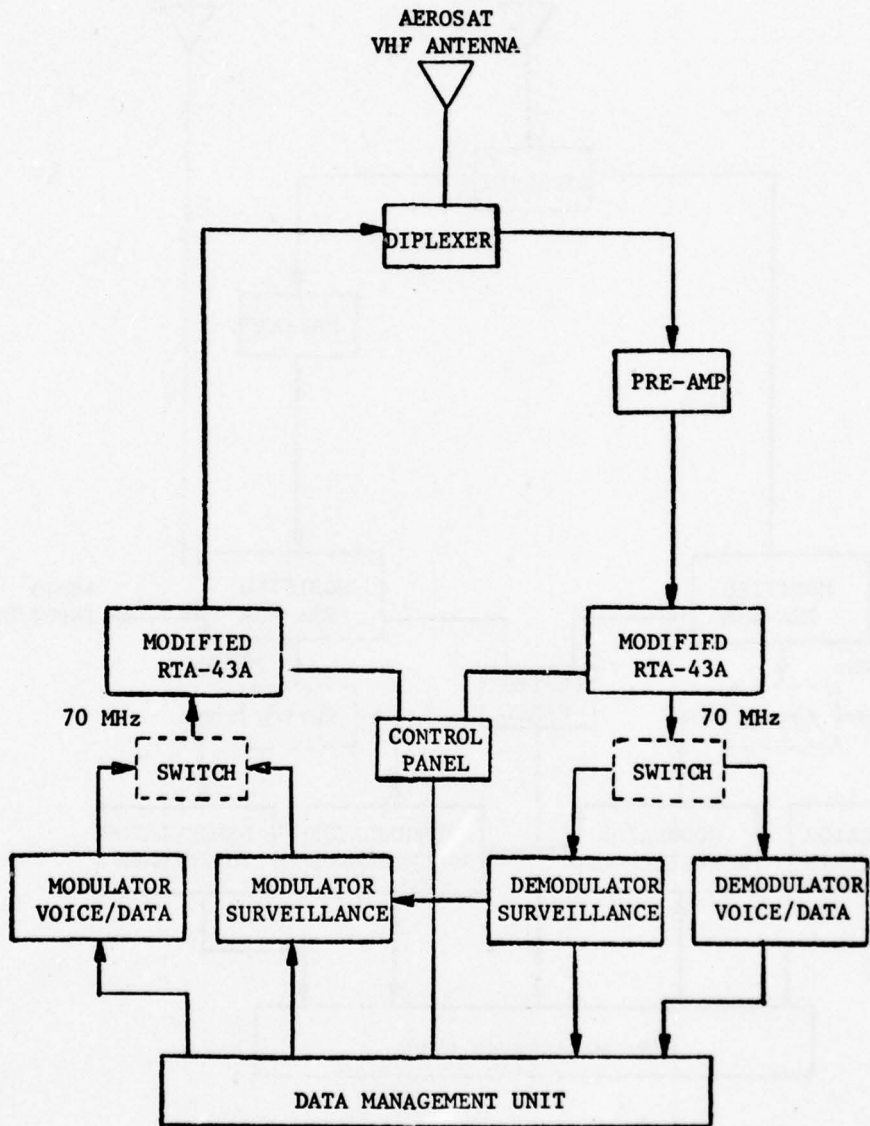

FIGURE 4.5. AEROSAT VHF TEST AVIONICS TYPE II SYSTEM (CONFIGURATION #5) FULL-DUPLEX WITHOUT TERRESTRIAL COMMUNICATION CAPABILITY

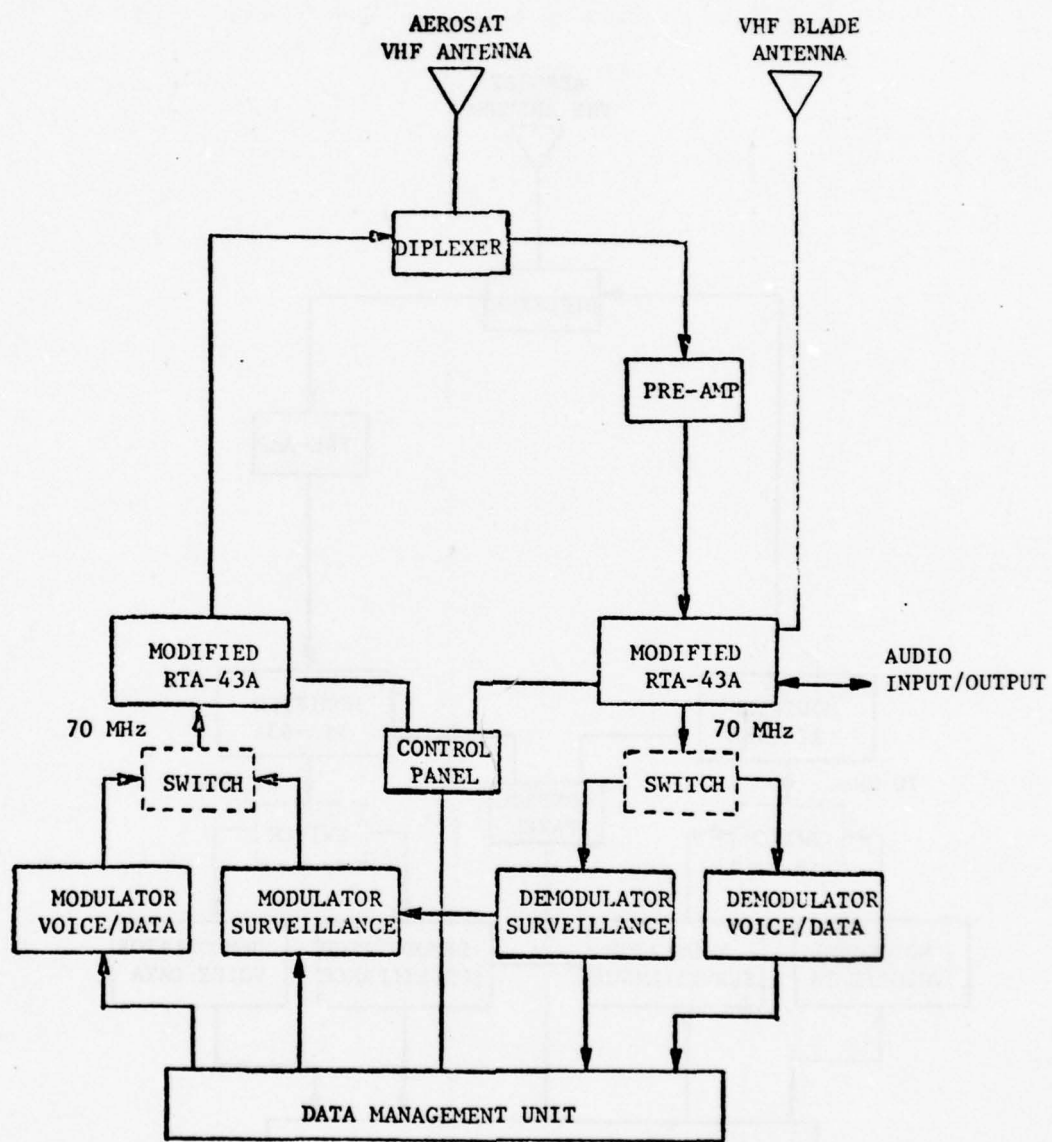

FIGURE 4.6. AEROSAT VHF TEST AVIONICS TYPE II SYSTEM (CONFIGURATION #6) FULL-DUPLEX WITH TERRESTRIAL COMMUNICATION CAPABILITY

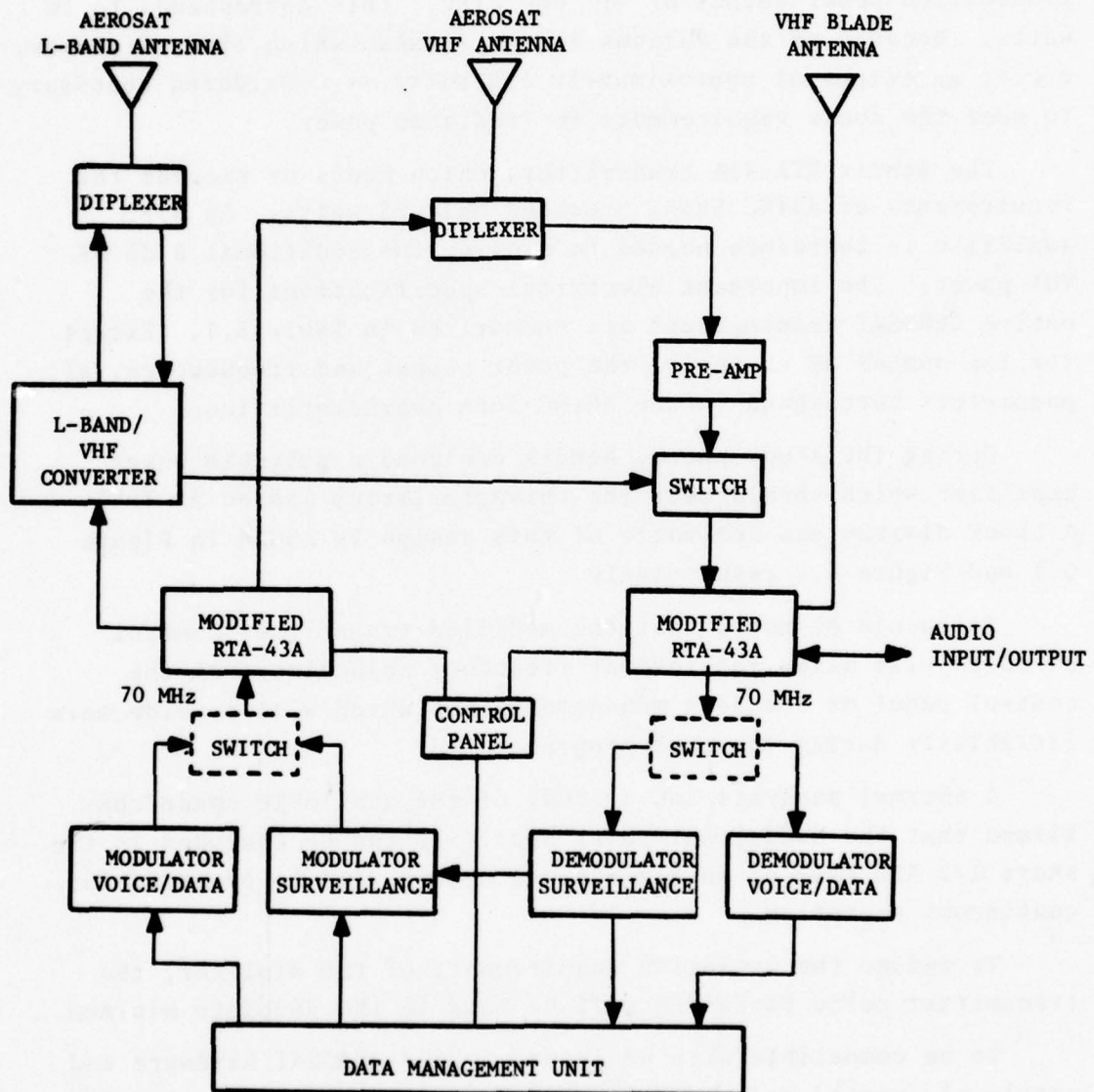

FIGURE 4.7. AEROSAT TEST AVIONICS TYPE III SYSTEM (CONFIGURATION #7) FULL-DUPLEX WITH TERRESTRIAL COMMUNICATION CAPABILITY

## 5. TRANSMITTER

The VHF aircraft-to-satellite link power budget specifies a transmitted power output of +17 dBw EIRP. This corresponds to 50 watts. Because of the various losses (transmission line, diplexer, etc.), an output of approximately 150 watts is considered necessary to meet the above requirements for radiated power.

The Bendix RTA-43A transmitter, which meets or exceeds the requirements of ARINC 566A, provides only 25 watts. An R.F. amplifier is therefore needed to provide the additional 8 dB of VHF power. The important electrical specifications for the entire AEROSAT transmitter\* are summarized in Table 5.1. Except for the number of channels, the power output and frequencies, all parameters correspond to the ARINC 566A characteristics.

During the study phase, Bendix designed a suitable power amplifier which should meet the characteristics listed in Table 5.1. A block diagram and schematic of this design is shown in Figure 5.1 and Figure 5.2 respectively.

It should be noted that the modified transmitter control circuits will allow independent frequency selection from the control panel or the data management unit which will provide more flexibility during the test program.

A thermal analysis and a study of the available space confirmed that the additional power amplifier can be included in the short 1/2 ATR case of an RTA-43A. A blower will be provided for continuous operation.

To reduce the isolation requirements of the diplexer, the transmitter noise bandwidth will be held to the absolute minimum.

To be compatible with projected L-Band AEROSAT hardware and previously tested modems it was necessary to modify the RTA-43A for 70 MHz modem input interface as shown in Figure 5.3.

---

\*All solid state.

TABLE 5.1. AEROSAT VHF TRANSMITTER CHARACTERISTICS

POWER OUTPUT (W)	150 MIN.
FREQUENCY RANGE (MHz)	131.425 to 131.975
NUMBER OF CHANNELS	22
HARMONIC ATTENUATION (dB)	67 MIN.
NONHARMONIC ATTENUATION (dB) (OVERALL)	87 MIN.
NONHARMONIC ATTENUATION (dB) (108 - 136 MHz)	-97 MIN.
DUTY CYCLE (AT 55°C)	CONTINUOUS
SUPPLY VOLTAGE (VDC)	28
MAX. ALTITUDE (FEET)	15,000 (SEE NOTE)
TEMPERATURE RANGE (°C)	-15 to +55

NOTE: The transmitter must be installed in a pressurized area because of cooling air density considerations.

$Q_1$  = SD 1175-2  
 $Q_2$  = SD 1015  
 $Q_3$  = SD 1219  
 $Q_4$  = SD 1019  
 $Q_5$  = 2N 6166  
 $Q_6$  = 2N 6166

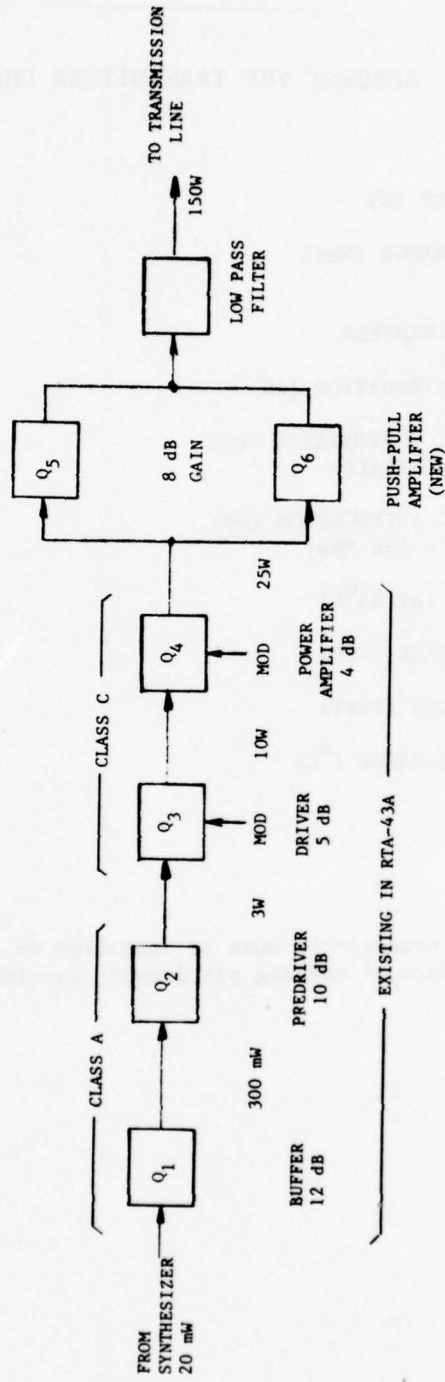

FIGURE 5.1. AEROSAT VHF TRANSMITTER

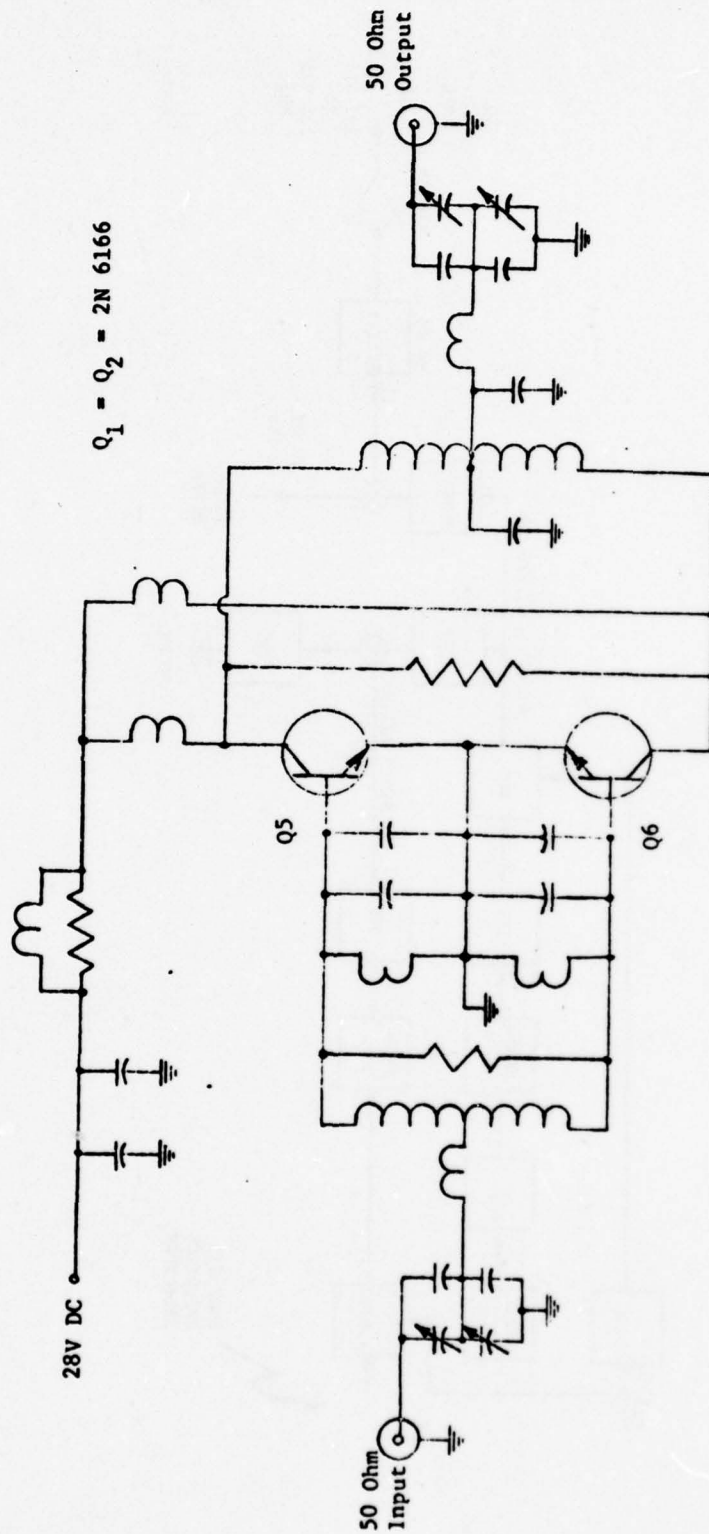

FIGURE 5.2. VHF 150-WATT PUSH-PULL POWER AMPLIFIER

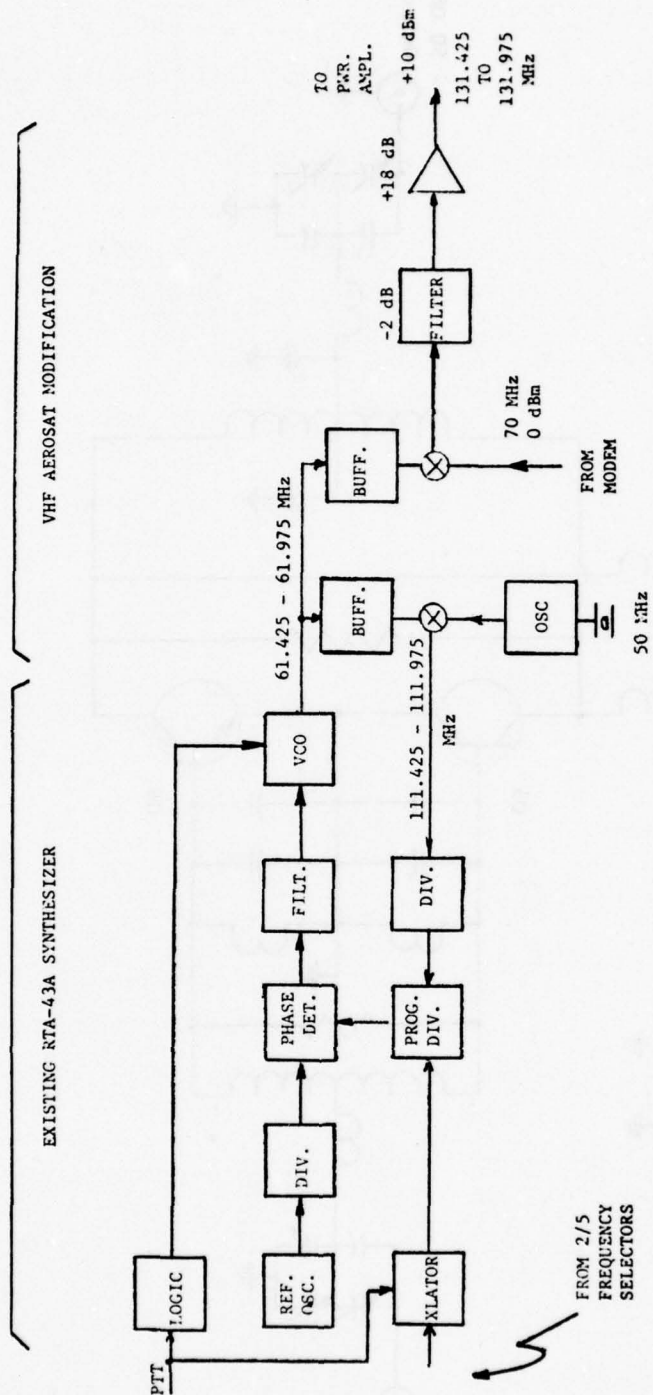

FIGURE 5.3. TRANSMITTER MODIFICATIONS

The original RTA-43A AM modulation circuits will remain operational. This circuitry provides the capability for controlling the transmitter power output level for AEROSAT test and evaluation applications.

The proposed RTA-43A modifications represent the most economical approach of several alternatives investigated.

## 6. RECEIVER

The AEROSAT VHF receiver is a dual conversion superheterodyne design using a remote low noise preamplifier, a VARICAP tuned preselector, and a conventional digital frequency synthesizer. Selectivity is determined in the first IF amplifier by a sharp MHz crystal filter. Both mixers use J-FET devices in an active balanced gain producing configuration.

The second IF amplifier is upconverted to 70 MHz by a 50 MHz crystal controlled oscillator/mixer combination. This conversion is a modification to the original RTA-43A VHF receiver and provides compatibility with external modems (GFE).

A block diagram of the AEROSAT receiver is shown in Figure 6.1. Specifications of the entire receiver are shown in Table 6.2. The preliminary schematic of this amplifier is shown in Figure 6.2.

It should be noted that the low noise preamplifier incorporates negative feedback in the second stage to reduce nonlinearities, thereby improving the intermodulation characteristics. In addition, the final design will also provide additional attenuation of the transmitter signal. This will help, in conjunction with the diplexer, to achieve the required overall transmitter-receiver isolation of approximately 85 dB.

A detailed effective system noise temperature analysis of six different preamplifier locations and coax transmission cable types was made in order to determine the optimum compromise. The pertinent configurations are shown in Figure 6.3. The corresponding effective system noise temperatures are summarized in Table 6.3.

A review of the various noise temperatures in Table 6.3 indicates that the best performance could be achieved with a preamplifier mounted on the antenna. Unfortunately, this configuration would also create maintenance and installation problems. As a compromise, a bulkhead mounted preamplifier has therefore been selected for a Boeing 747 installation. To facilitate installation

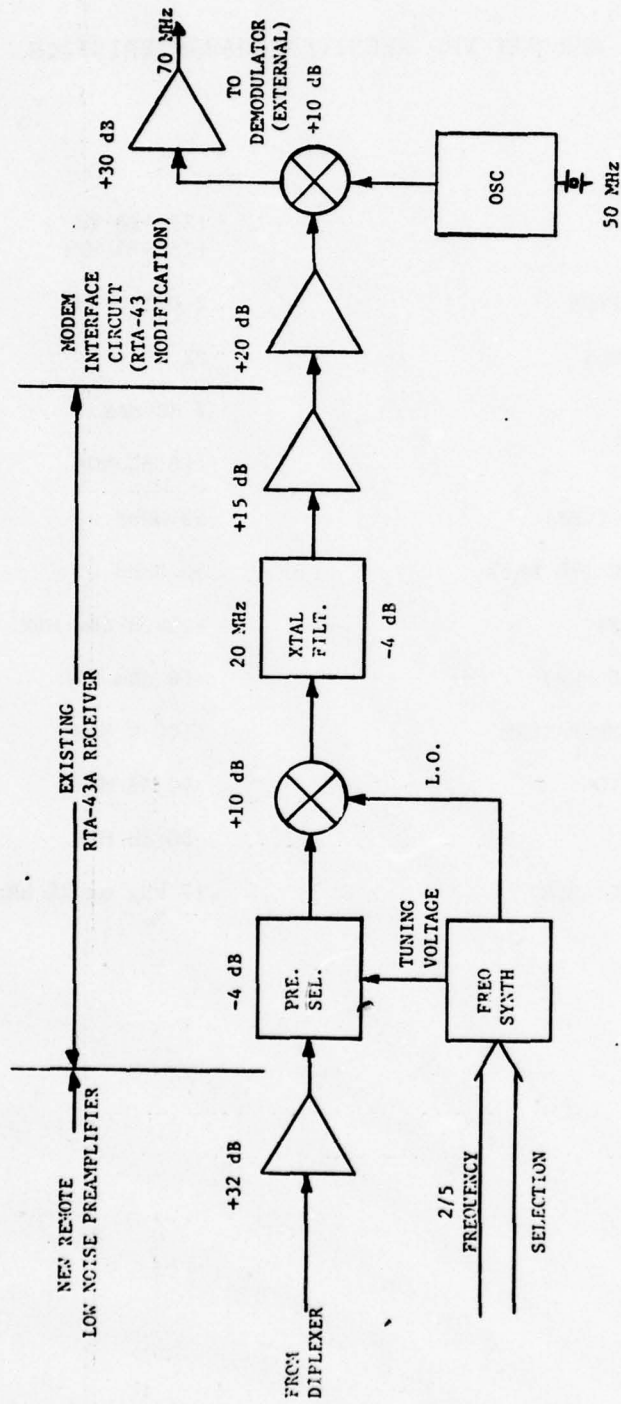

FIGURE 6.1. AEROSAT VHF RECEIVER

TABLE 6.1. AEROSAT VHF RECEIVER CHARACTERISTICS

FREQUENCY RANGE	125.425 to 125.975 MHz
FREQUENCY SELECTION	2-OUT-OF-5
NUMBER OF CHANNELS	22
NOISE FIGURE	2 dB MAX.
GAIN	110 dB NOM.
INPUT IMPEDANCE (VHF)	50 OHMS
OUTPUT IMPEDANCE (70 MHz)	50 OHMS
INPUT LEVEL (VHF)	-154.8 dBw MIN.
OUTPUT LEVEL (70 MHz)	-16 dBm MIN.
SYSTEM NOISE TEMPERATURE	1100 K MAX.
SPURIOUS REJECTION	-90 dB MIN.
IMAGE REJECTION	-80 dB MIN.
BANDWIDTH (SELECTABLE)	17 kHz or 25 kHz

TABLE 6.2. LOW-NOISE AEROSAT VHF PREAMPLIFIER CHARACTERISTICS

FREQUENCY RANGE	125.4 to 126 MHz
GAIN	32 dB NOM.
NOISE FIGURE	1.5 dB MAX.
INPUT IMPEDANCE	50 OHMS
OUTPUT IMPEDANCE	50 OHMS
INTERCEPT POINT	+10 dBm
REJECTION AT 131 MHz	-10 dB MIN.
TEMPERATURE RANGE	-15° to +55°C
SUPPLY VOLTAGE	+5 VDC
CURRENT	5 mA MAX.
DIMENSIONS	6.4" x 2.8" x 4.4" MAX.

NOTE: The preamplifier will include an integral limiter to prevent overloading.

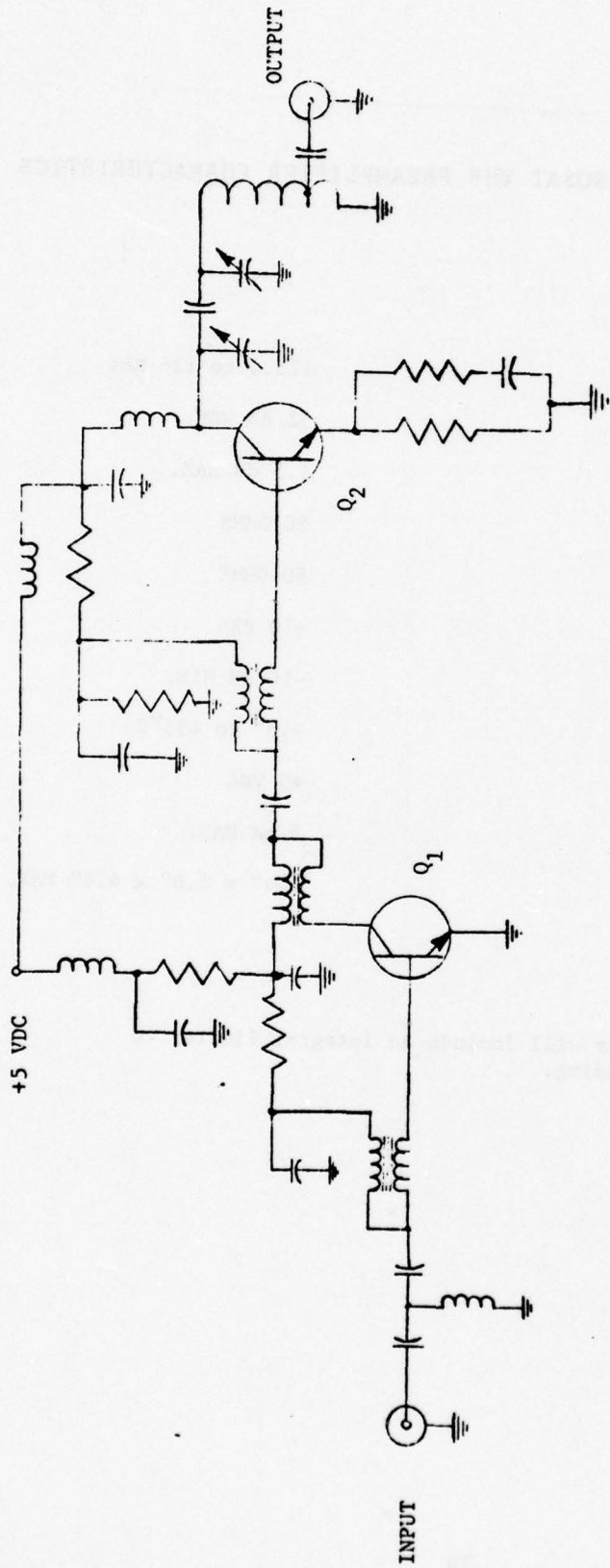

$Q_1$  - A 401  
 $Q_2$  - MFT 8006

FIGURE 6.2. VHF LOW-NOISE PREAMPLIFIER

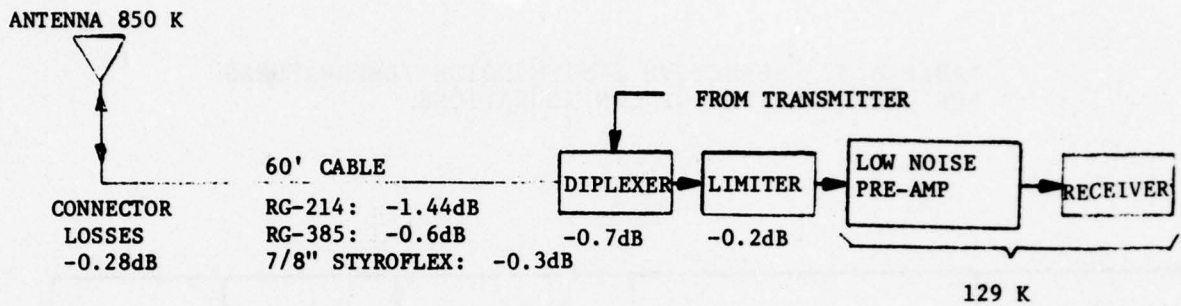

(a) LOW NOISE PRE-AMP IN RECEIVER

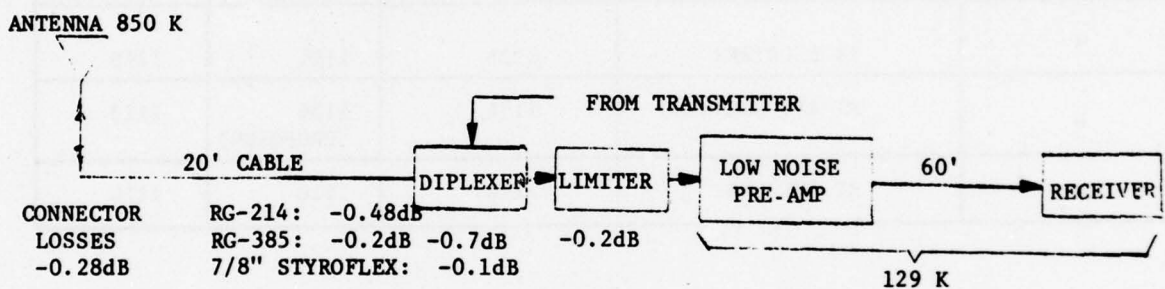

(b) LOW NOISE PRE-AMP AT AFT BULKHEAD (PROPOSED)

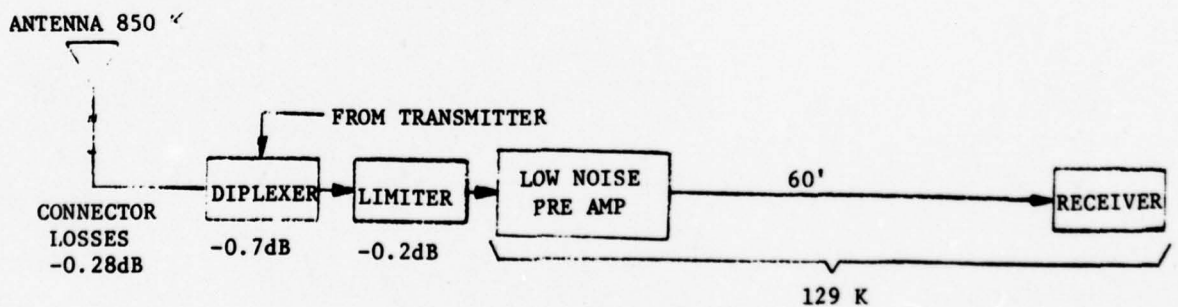

(c) LOW NOISE PRE-AMP AT ANTENNA

FIGURE 6.3. VHF PRE-AMPLIFIER LOCATIONS

TABLE 6.3. EFFECTIVE SYSTEM NOISE TEMPERATURES FOR VARIOUS TYPES OF CONFIGURATIONS

FIGURE 5.3	PRE-AMPL. LOCATION	NOISE TEMPERATURE		
		0.425" DIA RG-214	0.5" DIA RG-385	7/8" DIA STYROFLEX
a	IN RECEIVER	1326	1191	1149
b	AT AFT BULKHEAD	1174	1136 (PROPOSED)	1123
c	AT ANTENNA	1110	1110	1110

NOTE: Based on a Boeing 747 installation

and save cableweight, RG-385 coax is recommended rather than the lowest loss sytroflex cable. The slight degradation in system noise temperature (1136 K vs. 1100 K specified) will hopefully be acceptable.

To facilitate the use of previously tested modems, while at the same time providing compability with L-Band AEROSAT hardware, it was decided to include 70 MHz interface circuits in the VHF AEROSAT reciever.

The entire VHF AEROSAT receiver shown in Figure 6.1, except for the low-noise preamplifier, will be contained in one of the two RTA-43A short half ATR cases. The extra space available as a result of the transmitter modulator removal will be used for the 70 MHz interface circuits.

## 7. DIPLEXER

At the beginning of the VHF AEROSAT study phase a theoretical analysis of the diplexer characteristics, needed for full duplex operation, was made. The resulting preliminary specifications are listed in Table 7.1. Consultation with various vendors subsequently revealed that some of the specified parameters, particularly the insertion loss and isolation, could only be met with a very expensive device of enormous dimensions and weight, unsuitable for the AEROSAT airborne terminal.

An effort was therefore made to relax the critical specifications sufficiently to arrive at a design more practical for aircraft installations. In order to determine the minimum transmitter-receiver isolation required to meet system performance specifications, a number of tests were therefore conducted on a BELL QM-PSK MODEM and BENDIX RTA-43A Transceiver modified with suitable interface circuitry.

These tests revealed that 83 dB of isolation between the transmitter and receiver would be adequate. By assuming further potential improvements in the preamplifier and transmitter selectivity it was then decided to relax the isolation to 70 dB as shown in Table 7.2. Changes from the preliminary specifications (Table 7.1) are indicated by two asterisks. It should be noted that the assumptions made do introduce a development risk in this area. This was confirmed by cross coupling difficulties encountered during the tests.

The revised specifications (Table 7.2) were then submitted to nine vendors who specialize in VHF diplexers. Unfortunately, the response was still disappointing. Only three companies responded. The corresponding replies are summarized in Table 7.3.

It is apparent from Table 7.3 that, in spite of the reduced isolation requirements, the VHF AEROSAT diplexer will still be a very expensive and bulky device. The Table shows, for instance,

TABLE 7.1. PRELIMINARY DIPLEXER SPECIFICATIONS

Characteristic Impedance: 50 ohms  
Transmitter Power: 150 Watts\*  
Transmitter Pass Band: 131.42 to 131.98 MHz  
Loss Transmitter-to-Antenna: 1 dB max\* over transmitter passband  
Receiver Pass Band: 125.42 to 125.98 MHz  
Loss Antenna-to-Receiver: 0.7 dB max over the receiver passband  
Isolation Transmitter-to-Receiver: 100 dB at the receiver passband  
90 dB at the transmitter passband  
Phase Linearity:  $3^{\circ}$  max over any 25 kHz segment of passbands  
SWR: 1.3 to 1 max.  
Maximum Size: 7" x 7" x 30"  
Connectors: To be determined by vendor  
Maximum Weight: 40 lb

\*Transmitter-to-antenna loss is less critical. A loss higher than 1 dB can be tolerated as long as the transmitted power at the antenna terminal is not less than 125 watts without exceeding the transmitter power requirement of 180 watts.

TABLE 7.2. REVISED DIPLEXER SPECIFICATIONS

Characteristic Impedance: 50 ohms

\*\*Transmitter Power: 135 Watts\*

Transmitter Pass Band: 131.42 to 131.98 MHz

Loss transmitter-to-antenna: 1 dB max\* over the transmitter passband

Receiver pass band: 125.42 to 125.98 MHz

Loss antenna-to-receiver: 0.7 dB max over the receiver passband

\*\*Isolation transmitter-to-receiver: 70 dB at the receiver passband

\*\* 70 dB at the transmitter passband

Phase Linearity:  $3^{\circ}$  max over any 25 kHz segment of passbands.

SWR: 1.3 to 1 max.

\*\*Maximum Size: 7" x 7" x 20"

Connectors: To be determined by vendor

\*\*Maximum Weight: 30 lb

\*Transmitter-to-antenna loss is less critical. A loss higher than 1 dB can be tolerated as long as the transmitter power at the antenna terminal is not less than 125 watts without exceeding the transmitter power requirement of 180 watts.

\*\*Changes from preliminary specifications (Table 7.1)

TABLE 7.3. VENDOR REPLIES TO REVISED VHF AEROSAT DIPLXER SPECIFICATIONS

MANUFACTURER	INSERTION LOSS (dB)		ISOLATION (dB)		DIM.	VOL.	WEIGHT	QUANTITY PRICE \$				REMARKS
	RX	TX	RX	TX				2 each	12 each	100 each	250 each	
LORCH	1.5	1.5	70	70	6x7x15	630	20	2950	1292	325	300	Highest Loss No N.R.E.
	1.0	1.0	60	70	6x7x12	504	16	2655	1163	293	270	Smallest Volume No N.R.E.
	1.2	1.2	70	70	8x7x20	1120	36	3393	1486	375	345	Largest Volume No N.R.E.
	0.85	1.0	60	60	8x7x16	896	28	3098	1357	340	315	Lowest Isolation No N.R.E.
	0.7	1.0	70	70	7x7x20	980	30	2000 + NRE + NRE (120 days)	1650	950	885	NRE = \$7500
MCL	0.7	1.0	70	70	7x7x20	980	30	7700 + NRE	3800 + NRE	2200	2000	NRE = \$21,400 Most Expensive

NOTE: Numbers surrounded by circles indicate exceptions to specifications

that the two diplexers which meet all revised specifications will still measure approximately 7" x 7" x 20". The weight will be close to 30 lbs. The basic reason for this dilemma is the sharp cut-off characteristic of this diplexer which necessitates the use of 5- to 6-section filters with very low insertion loss. Since the losses are generally inversely proportional to volume, the diplexer must be inherently large.

In view of the critical nature of the diplexer it is strongly recommended to purchase a diplexer engineering model as soon as possible in Phase II. Extensive tests should be conducted to verify the conclusions reached during the study phase.

## 8. MODEMS

The airborne AEROSAT equipment must be capable of processing the following information: Voice Communications, Digital Data, and Surveillance Signals.

In the original contract, the ARINC #566 VHF transceivers, modified for AEROSAT experiments, specified self-contained modems for audio and digital data. The audio modulation was defined as narrowband FM (NBFM) meeting the general requirements of ARINC #566 while the data modulation was specified as DPSK with 1200 or 2400 bps data rates modulating the carrier.

To provide commonality between the L-Band and VHF AEROSAT hardware the original requirements for interface have subsequently been revised to permit interfacing at a standard frequency of 70 MHz. The modifications required to achieve this modem compatibility with the RTA-43A are discussed in Section 6.0(Receiver) and 5.0(Transmitter).

Interference tests have been performed by BENDIX using the BELL and MAGNAVOX MODEMS listed in Table 8.1.

The test performed on the MODEMS listed in Table 8.1 is summarized in Section 13.

In order to permit a better comparison between the L-Band and VHF AEROSAT systems, provisions had to be made in the VHF airborne AEROSAT terminal for an independent surveillance capability. The objective of the surveillance tests is to demonstrate, with the aid of two satellites, an independent position determining accuracy of 1 NM (95% CEP) independent of other airborne navigation systems. Some of the basic problems associated with this surveillance requirement have been studied by Bendix.

Since the modulation method to be used for the L-Band AEROSAT surveillance mode has not been selected yet at the time of this study, Bendix assumed that the multiple tone ranging

scheme employed for the Position Location and Aircraft Communications Equipment (PLACE) would be used for both L-Band and VHF. The PLACE system is described in Reference 24.

The Bendix study concluded that it would be feasible to incorporate a PLACE type multiple tone ranging mode in the VHF AEROSAT terminal.

The AEROSAT Modems will be customer furnished (GFE). At the time of this writing no decision had been made as yet regarding the specific MODEM design to be used for the VHF AEROSAT terminal.

TABLE 8.1 MODEMS TESTED

NO	MANUFACTURER	MODULATION		REMARKS
		VOICE	DATA	
1	BELL AEROSPACE	NBFM	DPSK	SIMULTANEOUS TRANSMISSION OF DATA AND VOICE ON A SINGLE CARRIER ARE ACHIEVED USING QUADRATURE MODULATIONS.
2	CO.	ADVIM		19.2 kHz CLOCK RATE. ADAPTIVE STEP SIZE DEPENDENT ON SLOPE DIGITAL OR ANALOG DEMOD. OUTPUT.
3	MAGNAVOX RESEARCH LAB	PDM SUPPR. CARR.	DPSK	SIMULTANEOUS TRANSMISSION OF DATA AND VOICE ON A SINGLE CARRIER ARE ACHIEVED USING QUADRATURE MODULATIONS.

NBFM = NARROW BAND FREQUENCY MODULATION

ADVIM = ADAPTIVE DELTA VOICE MODULATION

PDM = PULSE DURATION MODULATION

DPSK = DIFFERENTIAL PHASE SHIFT KEYING

## 9. CONTROL PANEL

### 9.1 BACKGROUND

Attachment III of the VHF AEROSAT Specifications, DOT FA75WA-3705, established the guideline for a VHF Transceiver Interface Unit and Control Panel. Three possible methods of implementing the designs were analyzed in the Control Panel Interface Study and in subsequent talks an acceptable approach was delineated. The Transceiver Interface Unit Design and Installation and the VHF AEROSAT Control Head Design and Installation reports were submitted, following those discussions, which outlined the internal designs of the TIU and Control Head and they provided specific wire listings along with connector part numbers. It was later determined that the terrestrial communication capability cannot be readily used during the AEROSAT experiments and therefore it was deleted to reduce the complexity and increase the reliability of the system. This section and the Interface Unit section reflect the final configuration proposed for the VHF AEROSAT System as a result of the Phase I study.

### 9.2 CONTROL PANEL CONFIGURATION

A drawing of the proposed control panel, Figure 9.1, is enclosed with a wire listing, Table 9.1. The control panel dimensions conform to Mil-Std-25212 specifications. It is 4 1/8" high, 5 3/4" wide and 4 7/8" deep.

#### 9.2.1 Active Frequency Display

The upper windows labeled "ACTIVE" will display the receive and transmit frequencies for the VHF AEROSAT System. The knob marked "DIM" and "PRESS TO TEST" will provide the active display dimming and test feature. The actual displays may be any seven segment displays available on the market, provided they can meet the space requirements for the system. The displays proposed are incandescent, such as the Penlite 04-30 1/4" character display.

TABLE 9.1. CONTROL PANEL CONNECTOR

J1

A	A		
B	B	} 0.1 MHz	TRANSMIT FREQUENCY
C	C		
D	D		
E	E		
F	C	} .01 MHz	
G	D		
H	Transmit Frequency Common		
J	A		
K	B	} 0.1 MHz	RECEIVE FREQUENCY
L	C		
M	D		
N	E		
P	C	} .01 MHz	
R	D		
S	Receive Frequency Common		
T	Auto-tune Override		
U	Arm		
V	High	} Volume	
W	Low		
X	Aircraft Panel Dimming		
Y	Power ON/OFF		
Z	+28V IN		
a	+28V IN		
b	Ground		
c	Ground		
d	Spare		
e	Spare		
f	Spare		
g	Spare		
h	Spare		
i	Spare		
j	Spare		
k	Spare		
l	Spare		
m	Spare		
n	Spare		
p	Spare		
q	Spare		
r	Spare		
s	Spare		
t	Spare		

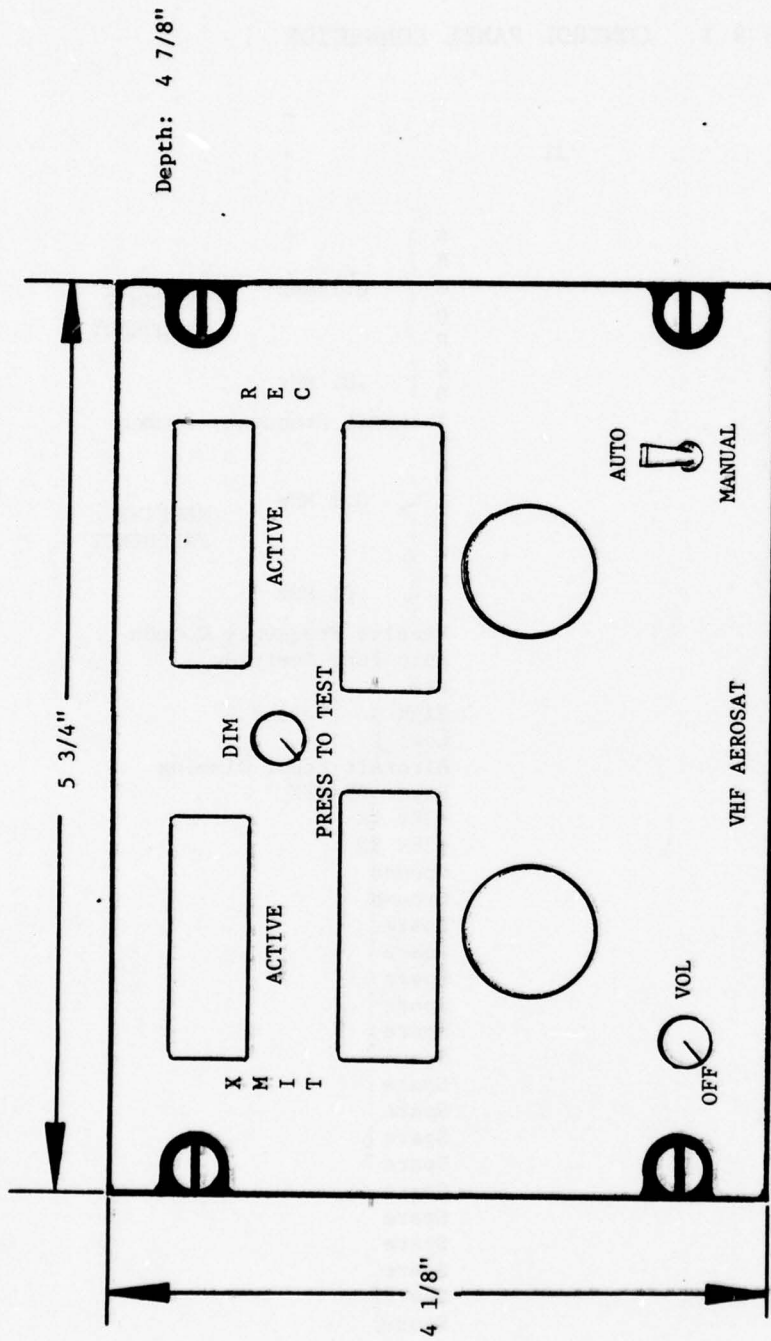

FIGURE 9.1. VHF AEROSAT CONTROL PANEL

There are a total of ten digits to be displayed; however, the first three digits in the receive and transmit frequencies are fixed (125 for receive and 131 for transmit). Therefore only four digits have to actually be decoded. To accomplish the decoding a multiplexing technique using 3 dual 9 line to 4 line data selectors is proposed. The final output would constitute a 2 of 5 code for one of the 4 digits.

The outputs of the data selectors would constitute an entire 2 of 5 code for one digit. The selected 2 of 5 code would be decoded by the programmable read only memory (PROM), into binary coded decimal (BCD). The BCD code would then be strobed in the appropriate decoder/latch for display. The "PRESS TO TEST" feature would illuminate all segments of the display for fault detection. The "DIM" potentiometer would vary the duty cycle of the driver chips to provide a dimming capability of the incandescent display. A block diagram of the control panel appears in Figure 9.2.

### 9.2.2 Manual Frequency Selection

The normal operation would be in the automatic (AUTO) mode. This would allow the Transmitter Interface Unit (TIU) to select either the frequency supplied by the Data Management System (DMS), or lacking a DMS supplied frequency, the control head frequency. If desired, the automatic select procedure can be overridden by the operator, such that the control head would always provide the transmit and receive frequencies. To enable the control head frequency, a ground would have to be placed on the manual receive/transmit common by the TIU. When operating in the manual mode, the frequency would be controlled by the wafer switches located in the control head, with separate switches for the transmit frequency offset controlled by the operator.

### 9.2.3 Control Switches

9.2.3.1 Volume and Power On/Off - The volume and power on/off is incorporated into one switch. The power on/off provides the con-

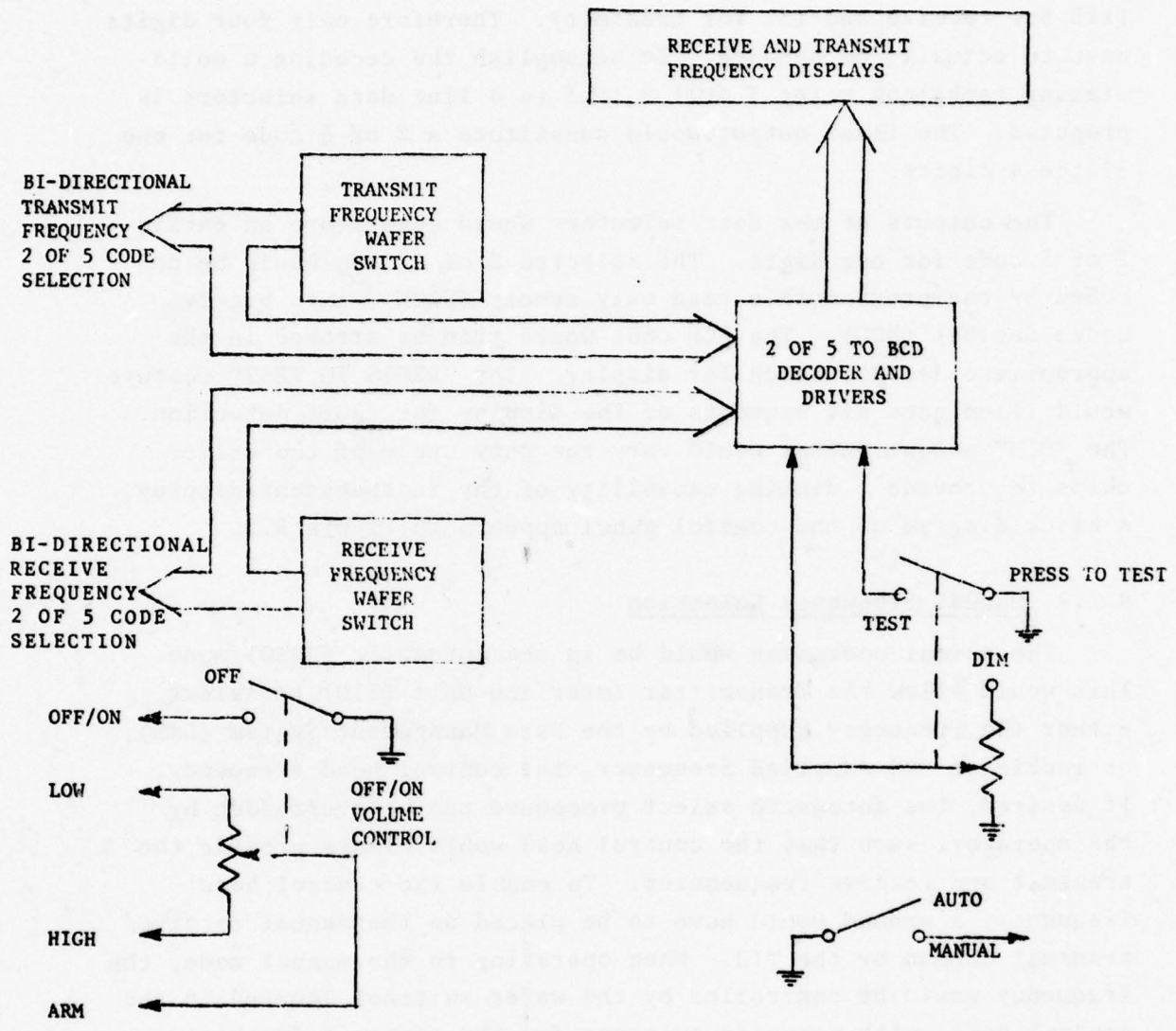

FIGURE 9.2. AEROSAT CONTROL PANEL

trol signal for the AEROSAT System. The volume control will be used to control the receiver audio amplifiers in the TIU.

9.2.3.2 Automatic Frequency Select Override - The automatic frequency select override toggle switch is labeled "AUTO" and "MANUAL" and it is used to inhibit the automatic frequency select capability of the TIU. When the switch is in the "AUTO" position the TIU can select the frequency provided by the DMS or control head. When in the AUTO mode, the active frequency displayed may or may not correlate with the manual frequency select window. However, when the switch is in the "MANUAL" position, the TIU will select the control head frequency, and the active displays should always indicate the same frequencies as the manual displays.

### 9.3 INSTALLATION

Table 9.1 is the signal and corresponding pin for the control head connector. The connector J1 is reference number M83723-02R2041N. The mate for J1 is M83723013R2041N-15S-20.

### 9.4 SUMMARY

This control panel design is the final configuration of the unit based upon the Phase I study. However, as the L-Band AEROSAT System is defined it is recommended to incorporate all AEROSAT (L-Band and VHF) into one control panel. Another approach may be to have all VHF controls, NAV., COMM., and AEROSAT, combined into one panel.

## 10. TRANSCEIVER INTERFACE UNIT (TIU)

### 10.1 BACKGROUND

As was referred to in Section 9, this section deals with the final configuration of the TIU as a result of the Phase I VHF AEROSAT study.

### 10.2 TRANSMITTER INTERFACE UNIT DESIGN

A wire listing, Table 10.1, is enclosed for the Transceiver Interface Unit. Table 10.2 is a listing of the signal polarities for the DMS to TIU interface. These signal levels are chosen such that the MDS/TIU interface has RS-232C compatible level signals. However, the interface is not an RS-232C interface because of the lack of some of the control signals specified on the RS-232C standards. If one of the commercially available IC's is used for the RS-232C driver and receiver circuits, advantage can be taken of the built-in threshold hysteresis to provide for open circuit protection. An open or logic "0" would be decoded as the same level, hence if the logic "0" is defined as the inactive state, the TIU can function if the DMS is not connected to the interface. The TIU would, by definition, select the manual control signals from the control head for frequency data. Also, if the TIU is disconnected the DMS would decode no response to a request to transmit, thus inhibiting the VHF AEROSAT portion of the DMS. A block diagram of the system appears in Figures 10.1.

The removal of the terrestrial capabilities from the TIU will simplify the design by eliminating the need for a relay and some of the serial data circuitry. The complicated mixing for the PTT signals is still required however.

Table 10.1 gives the pin and corresponding signal designations for the TIU connector. The size of the connector remains unchanged and the signals that were associated with the terrestrial mode were simply deleted.

TABLE 10.1 TIU CONNECTOR PIN DESIGNATION PT1A (TOP) CONNECTOR.

<u>Pin Number</u>	<u>Signal Designation</u>
1	Spare
2	Spare
3	Spare
4	Spare
5	Spare
6	Spare
7	Spare
8	A
9	B
10	C 0.1 MHz
11	D RECEIVE
12	E FREQUENCY
13	C 0.1 MHz
14	D
15	Receive Frequency Select Common
16	Spare
17	Spare
18	Spare
19	Spare
20	Spare
21	Spare
22	Spare
23	A
24	B
25	C 0.1 MHz
26	D TRANSMIT
27	E FREQUENCY
28	C 0.1 MHz
29	D
30	Transmit Frequency Select Common
31	Spare
32	Received AEROSAT Audio High
33	Received AEROSAT Audio Low
34	Spare
35	Spare
36	Spare
37	Spare
38	Tape Recorder Audio High
39	Tape Recorder Audio Low
40	Spare
41	Headset Audio High
42	Headset Audio Low
43	Spare
44	Spare
45	Spare
46	4 Wire Microphone PTT
47	AEROSAT Audio
48	AEROSAT Audio Return
49	AEROSAT PTT
50	Spare
51	Spare
52	Tape Recorder Input
53	Tape Recorder Return
54	Spare
55	Spare
56	Microphone Input
57	PTT and Audio Return

TABLE 10.1 TIU CONNECTOR PIN DESIGNATION PT1B (BOTTOM)  
CONNECTOR (CONCLUDED)

PT1B (Bottom) Connector

<u>Pin Number</u>	<u>Signal Designation</u>
1	Airframe Ground
2	Airframe Ground
3	Spare
4	ON/OFF
5	Spare
6	Spare
7	Spare
8	+28V DC
9	+28V DC
10	Spare
11	Spare
12	Spare
13	Received Clock
14	Data Clock
15	Received Data
16	Data
17	Spare
18	Spare
19	Spare
20	Demod Lock
21	Carrier ON
22	Bandwidth Select
23	Spare
24	Transmitter Enable
25	Request to Transmit
26	Clear to Transmit
27	Transceiver Ready
28	Transmit Data
29	DMS Transmit Data
30	DMS Transmit Data Clock
31	Transmit Clock
32	Frequency Data
33	Frequency Clock
34	Auto-tune Override
35	Auto-tune
36	Spare
37	Spare
38	Spare
39	Spare
40	Spare
41	Spare
42	Spare
43	Spare
44	Spare
45	Spare
46	Spare
47	Spare
48	Spare
49	Spare
50	Spare
51	Spare
52	Spare
53	Spare
54	Spare
55	Spare
56	Spare
57	Spare

TABLE 10.2. DMS/TIU INTERFACE SIGNAL POLARITIES.

<u>Signal Name</u>	<u>Signal Polarity*</u>
1. Frequency Data	Logic "1" = -5V
2. Frequency Data Clock	Logic "1" = -5V
3. Auto-tune	Logic "1" = -5V
4. Carrier ON	Undetermined
5. Transceiver Ready	Logic "1" = -5V
6. Request to Transmit	Logic "1" = -5V
7. Clear to Transmit	Logic "1" = -5V
8. Transmitted Data	Undetermined
9. Transmitted Data Clock	Undetermined
10. Received Data	Undetermined
11. Received Data Clock	Undetermined

\*NOTE: A Logic "1" denotes the active signal level

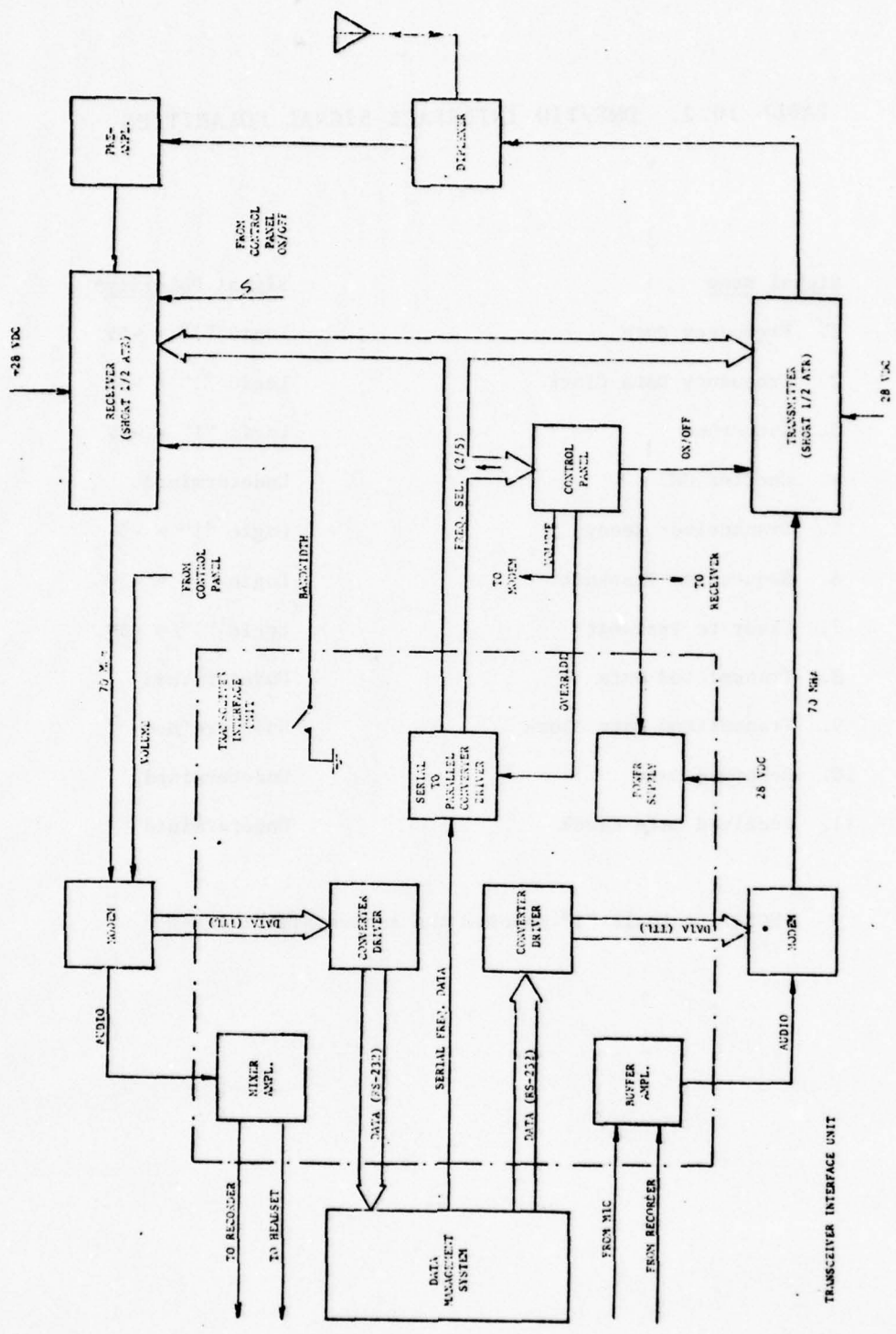

FIGURE 10.1. TRANSCIVER INTERFACE UNIT

BEST AVAILABLE COPY

### 10.2.1 Auto-Tune

The Auto-tune capability allows the DMS to select the active AEROSAT frequency from either the TIU or the control head. The TIU frequency is the one that is supplied by the DMS to the TIU via the serial frequency data bus and the control head frequency is selected by the pilot, utilizing the wafer switches described in the control head design report. When the system is in "Auto-tune", the TIU will sense the open on the "Override" line and enable the TIU frequency. The 2 of 5 code data lines are a tri-state bus controlled by the TIU. The TIU can disable its own drivers, since they are tri-state buffer/drivers, or the control head switches, since the TIU provides the ground for the control head frequency select common lines. Given that the system is in the Auto-tune mode, the DMS would place a logic "1" (-5V) on the Auto-tune signal line to select the TIU supplied frequency or a logic "0" (+5V) to select the control head frequency. In either case, the control head would display the active frequency.

### 10.2.2 Serial Frequency Data

With the removal of the terrestrial capabilities, the actual interconnection for the series data bus would remain unchanged. However, the need for the full 15 bit 2 of 5 codes of the transmit or receive frequencies is no longer required. In an AEROSAT only mode, the only tunable frequencies are the 0.1 and .01 MHz signals since the receive frequency is always 125.---MHz and the transmit frequency is always 131.---MHz. Therefore, only 7 bits are needed for each frequency or 14 bits for both frequencies.

When the AEROSAT system is operating in the Auto-tune mode, the DMS may select the transmit and receive frequencies in the TIU. These frequencies are supplied to the TIU by the DMS via a serial frequency data bus. Figure 10.2 depicts the data transfer from the DMS to the TIU. The clock frequency may be any frequency that is compatible with the RS-232C type interface (less than or equal to 20 kHz). However, since the AEROSAT Modems accept data at either 1200 or 2400 Hz, it is assumed that the DMS to TIU data transfer

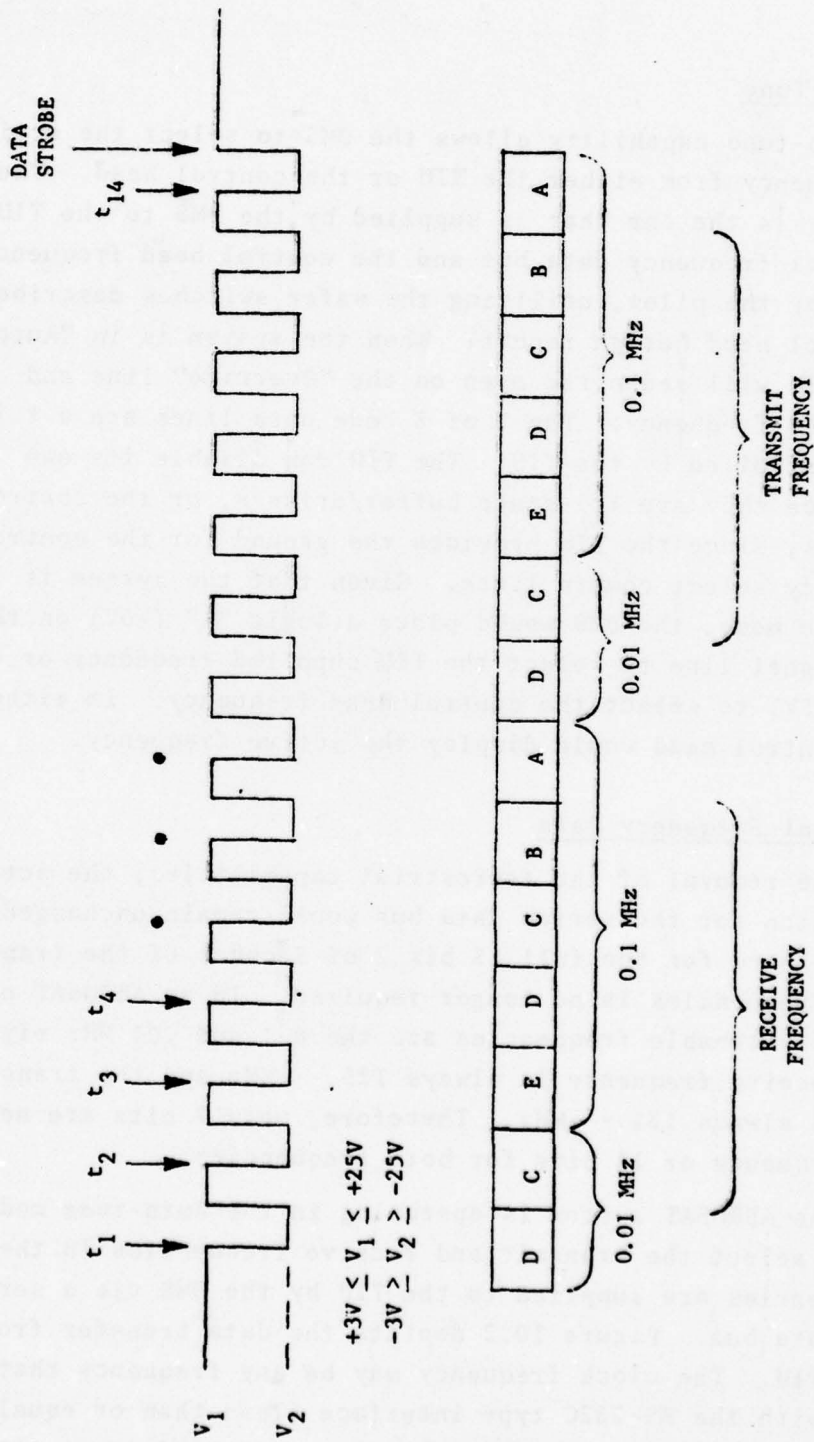

FIGURE 10.2. TIMING DIAGRAM FOR SERIAL DATA TRANSFER OF CONTROL FREQUENCIES.

rate will be the same. As illustrated on Figure 10.1, the clock line should transition between  $V_1$  (greater than or equal to +3 volts but less than or equal to +25 volts) and  $V_2$  (less than or equal to -3 volts but greater than or equal to -25 volts) when the clock line is active. When dormant, the clock line should stay at  $V_1$ . The clock should be 50% duty cycle, when active, with the rising edge of the clock coincident with the data edge ( $\pm 1$ usec). The DMS should provide 14 clock pulses for the 14 data bits with the first data bit appearing on the interface for 1/2 clock period before the first negative going transition of the clock line. The TIU will clock the data into the shift register and trigger the monostable multivibrator on each falling edge of the clock ( $t_1, t_2, t_3 \dots t_{14}$ ).

On each rising edge of the clock, the counters in the TIU will transition until 14 rising edges have been counted. Then, the counter chain will generate a strobe data signal which will load the information contained in the shift register chain into latches which drive the tri-state buffers for the TIU generated 2 of 5 code. The serial data must be the receive frequency 2 of 5 code least significant digit and least significant bit first; i.e., receive frequency .01 MHz "D" bit first. The 2 of 5 code involves grounding two of five lines for any given encoded number. Since the RS-232C signal levels are inverting, only two bits of a five bit code should be at  $V_1$ . The remaining three bits should be at  $V_2$ . In the cases of .01 MHz data code, the appropriate frequency can be determined only two of the five bits. The monostable multivibrator will reset the counters if it isn't retriggered within 1 ms. This will prevent the counters from strobing in the frequency data by counting noise pulses that may be injected into the data bus. The "Auto-tune" signal from the DMS will select the frequency to be used. A logic "1" (-5V) on the DMS interface will select the control head for the frequency code and a logic "0" (+5V) will select the DMS supplied frequency provided that the system is in the "Auto" frequency select Mode. If the DMS unit is not connected, the TIU will sense the Auto-tune line as a logic "0" and select the control head frequency.

### 10.2.3 Audio Input/Output

The reconfigured AEROSAT system will also have two audio inputs. The tape input is 620 ohm impedance and the microphone input is 150 ohm impedance. The two inputs are mixed in a dual FET transistor with an adjustment for each summing component such that an equal strength signal output can be obtained from either input. The compression adjustment is used to prevent either input from overdriving the system. These three adjustments are located on the front of the TIU container for operator convenience.

The received audio input is fed into two buffers with unity gain for driving a headset and tape recorder. Both audio outputs have 620 ohm impedance. The volume control on the control head is used to adjust the received AEROSAT audio level at the demodulator modem.

### 10.2.4 Press To Talk

The Press-to-Talk (PTT) signal is a switched ground that is used to key the transmitter. However, there are three different types of data (microphone, tape recorder, and DMS) that may need to key the transmitter at different times. To further complicate the issue, there are two different types of microphones that may be used (three wire and four wire). The AEROSAT PTT is a separate signal from the audio return, since it is used to key the transmitter and the audio return goes to the modulator modem, and it should respond to all PTT inputs. The four different data keys is accomplished by the "wired OR" of diodes CR1, CR2, CR3 and CR4.

The transmitter may be keyed by placing a ground on the cathode of any of the four diodes. The four wire microphone has separate leads for the PTT and the audio return. Therefore, the audio return is connected to T2 and the PTT lead is connected to CR4. However, the three wire microphone has the audio return and PTT combined on a single lead. This dilemma is handled by isolating the PTT from the audio amplifier/mixer by a capacitor on T2. The PTT is then connected to the array by CR1. The tape recorder is simply an audio input; however, a separate key is

provided by CR3 and the transmitter at any time. The PTT for the DMS is provided by the request to transmit and AEROSAT mode signals through CR3.

#### 10.2.5 Transmit and Receive Data Signals

The DMS transmit data and clock are received as RS-232C level signals and the TIU simply converts these signals to a TTL level for the AEROSAT modulator modem. The received clock and data are converted from a TTL level to an RS-232C level for the DMS/TIU interface.

#### 10.2.6 Control Signal

The "transceiver ready" signal is a logic 1 (-5V) to signify that power has been applied to the VHF AEROSAT System. Since the TIU power supply and the switched power for the transceivers are controlled by the ON/OFF switch, the TTL to RS-232C interface gate is simply wired to the TIU power supply.

The "CLEAR TO XMIT" signal is an RS-232C level signal generated by the TIU when the TIU receives a request to transmit signal from the DMS and the system is in the AEROSAT Mode.

The "CARRIER ON" signal is an RS-232C level signal that is generated when the AEROSAT modem detects a demodulator lock condition.

The "BANDWIDTH SELECT" is a TTL compatible signal that is controlled by a toggle switch on the TIU. The narrow bandwidth is manually selected by placing the toggle switch in the "NARROW" position.

The "ON/OFF" signal simply provides a control for the TIU power supply. The TIU power supply should accept a primary power of +28V DC with outputs of +15.5V DC, +10V DC, and +5V DC.

### 10.3 INTERFACE

The TIU will use ARINC connector number DPX2-57P-57P-34B. This is a dual rectangular connector with 114 pins. The airframe

mate for this connector is DPX2-57S-57S-33B. Table 10.1 gives the pin and signal designations for the TIU.

#### 10.4 SUMMARY

This report outlines the final configuration of the TIU without dealing with any changes in the container size as a result of eliminating the terrestrial capabilities. This report on the TIU also doesn't include any material concerning the surveillance modem. The primary changes in the TIU design is the removal of the relay for audio switching and the simplifying of the serial frequency data control circuitry. An attempt was made to account for all necessary interconnections between the various subsystems of the AEROSAT System. However, future design work or modifications to this approach may necessitate a change in the circuits and interconnections listed in this report.

## 11. AIRBORNE ANTENNAS

The VHF airborne AEROSAT antenna must meet all the normal, stringent requirements of aircraft antennas. This includes low drag and weight, adequate rigidity to withstand severe mechanical stresses in flight, high altitude performance, minimum precipitation charging, lightning protection, etc.

In addition to these basic requirements, the airborne AEROSAT antenna must also be designed to cope with two phenomena that are severe in satellite avionics systems, namely: Faraday rotation of the signals by the ionosphere, and multipath effects due to reflections from the surface of the earth.

The Faraday rotation effects can be minimized by the use of circular polarization on both the satellite and aircraft.

To discriminate against multipath signals, maximum antenna attenuation is required in the lower hemisphere.

And finally, to assure adequate signal strength at all aircraft headings and attitude, the antenna gain must be maximized while, the pattern holes are minimized.

The above requirements must be satisfied in a simple, reliable and aerodynamically designed antenna. A summary of the most important specifications for the AEROSAT aircraft is listed in Table 11.1.

Bendix Avionics has made a survey of available VHF SATCOM antennas regarding their relative performance and installation requirements. A list of these appears in Table 11.2. Several vendors were also contacted in order to find a potential source for new alternative antennas with improved performance.

It is generally recognized today that for satellite applications high antenna gain is very desirable, particularly at low elevation angles above the horizon. This is a critical consideration for the downlink (satellite-aircraft) which is limited by the relatively low satellite transmitter power.

TABLE 11.1 VHF AEROSAT AIRCRAFT ANTENNA SPECIFICATIONS

1. Frequency Receive	125.4 to 126 MHz
Transmit	131.4 to 132 MHz
2. Transmitter Power	100 Watts max.
3. Polarization	Circular
4. Azimuth Pattern	Omni Directional
5. Elevation Pattern	10° - 90° Above Horizon
6. Ellipticity	6 dB max.
7. Discrimination in Lower Hemisphere	-15 dB min.
8. VSWR	1.5:1 max.
9. Efficiency	90% min.
10. Aerodynamic Drag	15 lbs. max. (Mach 0.86 at 30,000 feet)

TABLE 11.2. AVAILABLE VHF AEROSAT AIRCRAFT ANTENNAS

MANUFACTURER	TYPE	WEIGHT (lb)	DIMENSIONS	GAIN (dect)	MODES	POLARIZATION	QTY PRODUCED	DRAG (lb)	DEVELOPPED (YEAR)	REMARKS
Boeing	SLOT	75	16' x 10'	5.5 Peak	1	L	200	5 (est)	1967	B747 only (cavity required) Broadband
	CROSSED LOOP	11.5	3.5" x 15" x 30"	4.5 Peak	1	L & R	2	5	1972	Low drag (Flush) Narrow Band
Dorne & Margolin*	COMB. TURN-STILE BLADE	40	19" x 8" x 34"	3/1 Avge	2	L	12	15	1967	High drag Narrow Band (See Note)

\*This antenna cannot be installed on 3-engine jets such as the B-727, L-1011, DC-10. This is due to the danger of antenna ice breaking off and being sucked into the tail engine.

Unfortunately, high gain is always associated with narrow beam width and this, in turn, may require pattern switching or steering. This technique has already been accepted for the L-Band AEROSAT band, but not yet for the VHF band.

BOEING designed and developed two different VHF satellite communications antennas. The first one, a SLOT DIPOLE, was specifically designed in 1967 for the BOEING 747. The second antenna, a low silhouette CROSSED LOOP type, was developed under contract to TSC in 1972. These antennas are illustrated in Figures 11.1 and 11.2. Their essential characteristics are listed in Table 11.2.

DORNE & MARGOLIN has also developed an antenna which is suitable for the AEROSAT program (Figure 11.3). Its electrical performance appears superior to the BOEING SLOT DIPOLE if mode switching is employed. Installation is much simpler but the relatively high drag is a definite drawback to be considered. The essential characteristics of the DORNE & MARGOLIN antenna are also listed in Table 11.2. A comparison with the BOEING SLOT antenna is shown in Table 11.3.

In conclusion it is felt that the optimum choice for the VHF AEROSAT aircraft antenna will depend primarily on the type of aircraft to be equipped.

The best choice for a Boeing 747 would probably still be the original BOEING slot antenna. It has apparently adequate performance and is already installed in many aircraft. Retrofit is easy for the newer 747 aircraft which are not equipped with SATCOM antennas or the older 747 versions where the antennas have been removed. It should be possible to refurbish some of these original antennas and retune them to the AEROSAT frequencies.

For the Boeing 727 and the new high performance wide-body jets such as the DC-10, L-1011 and A-300, the low drag crossed loop antenna developed by Boeing would probably be the best choice, provided that the small quantity production cost can be economically justified.

For older jet aircraft such as the Boeing 707, Douglas DC-8, and Convair 880, the DORNE & MARGOLIN antenna is probably the best choice since some of the original antennas are still available for the AEROSAT evaluation.

The development of completely new antennas with very low drag does not appear to be justifiable at this time in view of the uncertainty associated with the frequency band choice for the AEROSAT System (L-Band or VHF).

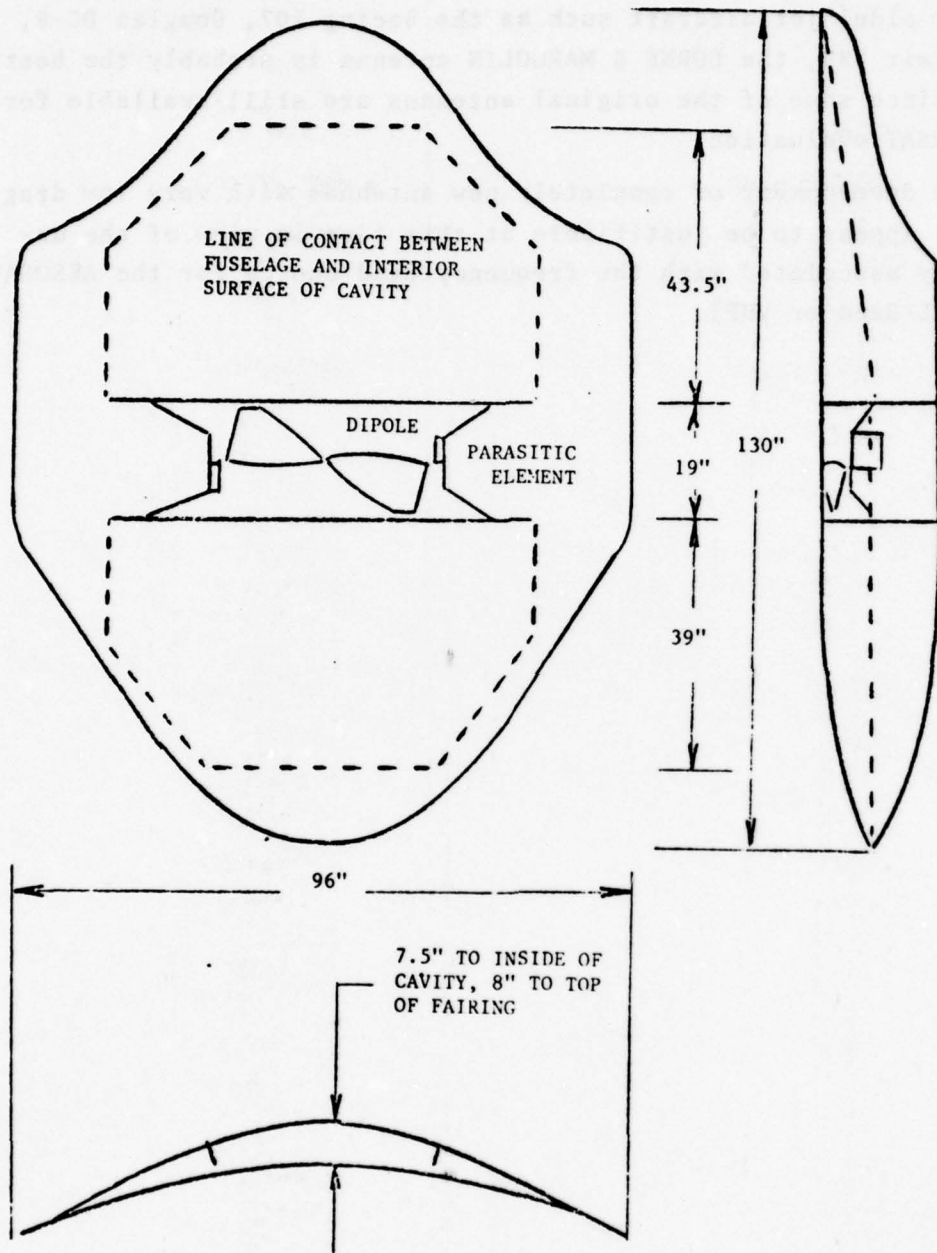

FIGURE 11.1. BOEING 747 SLOT DIPOLE ANTENNA  
COPY OF BOEING SKETCH

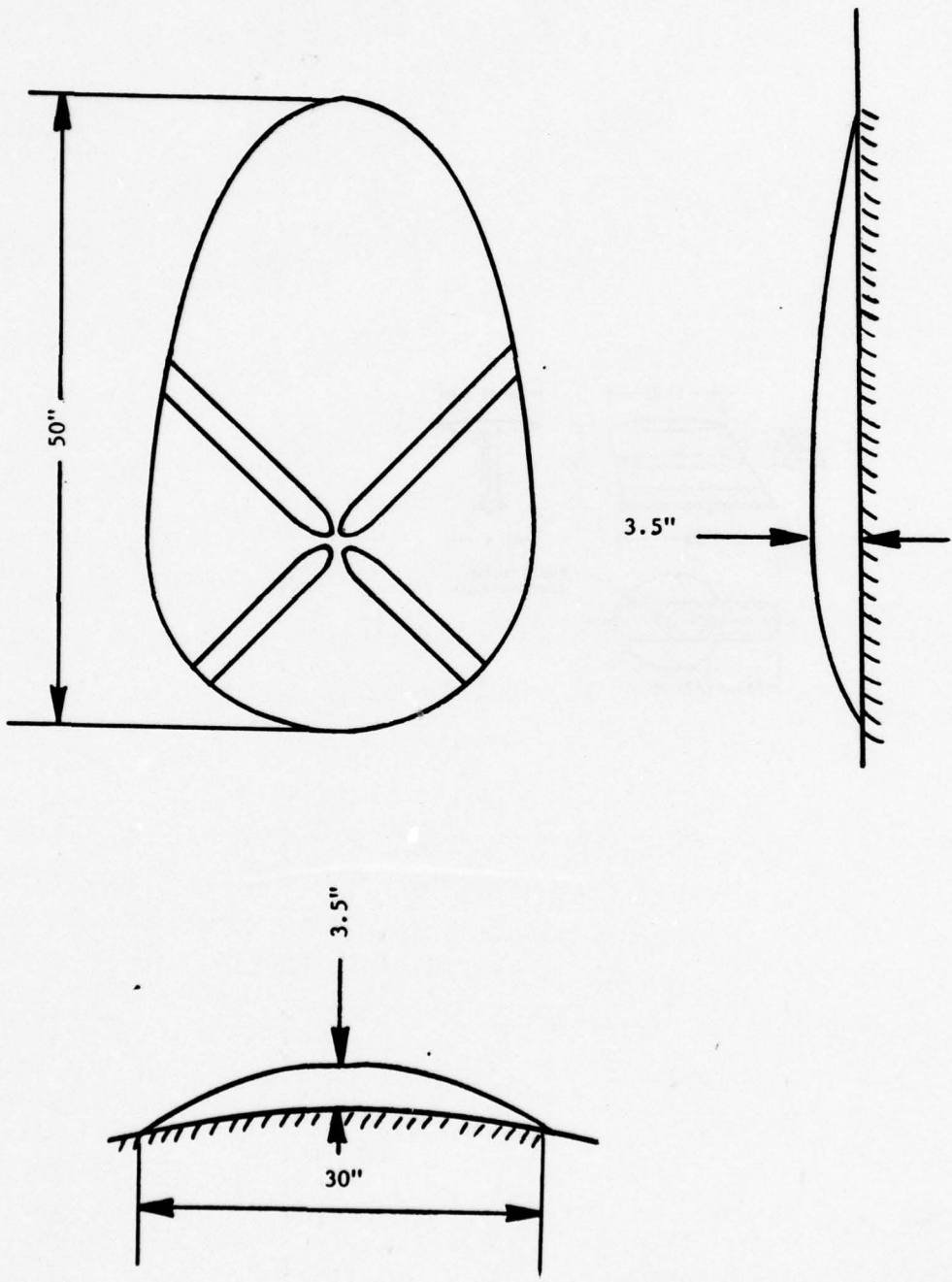

FIGURE 11.2 BOEING CROSSED LOOP ANTENNA

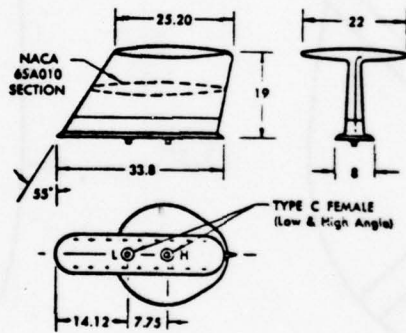

FIGURE 11.3 DORNE & MARGOLIN VHF AIRBORNE SATELLITE  
 COMMUNICATIONS ANTENNA TYPE DMC 33-2

TABLE 11.3 COMPARISON OF BOEING 747 SLOT DIPOLE WITH DORNE & MARGOLIN TURNSTILE ANTENNA

Frequency MHz	Angle (degr)	GAIN dB			
		Boeing 747 Slot Dipole		Dorne & Margolin Turnstile Antenna	
		Minimum	Average	Minimum	Average
124	10	-4.73	-0.9	0	+1.9
	20	-3.0	+0.9	+1.8	+3.8
	90	+5.4	-	+6.4	-
130	10	-2.9	-0.9	0.2	+2.0
	20	-2.3	+0.5	+2.0	+3.8
	90	+5.7	-	+6.5	-

Note: The angles shown above are with reference to the horizon.

## 12. RELIABILITY

### 12.1 BACKGROUND

The reliability study of the final configuration for the VHF AEROSAT System used Mil-Std Mil-HDBK-217B. An extensive computer analysis was made using various temperatures and environments. The military standards used for the environments are "Airborne Inhabited", "Airborne Uninhabited", and "Ground Fixed" (See glossary for definitions). Since these environments are for the military, the conditions are more harsh than would be encountered in commercial aircraft (i.e., the airborne inhabited cockpit of a fighter aircraft would subject the unit to wide temperature excursions and even rain when the canopy is open). Therefore, Bendix feels that the military airborne inhabited environment would closely simulate the avionics bay of a commercial aircraft and that the military equivalent of ground fixed environment would correspond to a commercial aircraft cockpit.

### 12.2 CONCLUSION

The sample MTBF calculation in Table 12.1 would be the system MTBF for a typical AEROSAT installation. It is felt that the 2084 hr. MTBF is a worst case for all practical purposes in an AEROSAT VHF system. This reliability study is based upon a preliminary estimate of parts as a result of the Phase I study.

TABLE 12.1 MTBF NUMBERS OF VHF AEROSAT UNITS FOR VARIOUS ENVIRONMENTS

	MTBF (Hr)					
	55°C			70°C		
	A <sub>U</sub>	A <sub>I</sub>	G <sub>F</sub>	A <sub>U</sub>	A <sub>I</sub>	G <sub>F</sub>
Control Head	3,261	3,857	6,102	2,958	3,512	5,587
Low Noise Amp.	176,405	398,638	1,005,527	143,826	336,583	851,858
VHF Transmitter	5,994	9,535	30,004	5,100	8,110	23,268
Transceiver Interface Unit	10,700	15,082	51,198	8,625	12,045	36,898
Receiver and Modem Conv.	4,175	6,960	20,528	3,572	5,872	15,744

A<sub>U</sub> = Airborne Uninhabited

A<sub>I</sub> = Airborne Inhabited

G<sub>F</sub> = Ground Fixed

Sample calculation for system MTBF:

Control Head and Low Noise Amp. at 55°C and G<sub>F</sub> environment

Transceiver, TIU, and Transmitter at 55°C and A<sub>I</sub> environment

$$\frac{1}{\text{System MTBF}} = \frac{1}{6102} + \frac{1}{1,005,527} + \frac{1}{9,535} + \frac{1}{15,082} + \frac{1}{6,960}$$

System MTBF = 2,084 hours

### 13. ELECTROMAGNETIC INTERFERENCE (EMI)

Bendix Avionics studies the potential intra-aircraft EMI in order to determine susceptibility and interference effects with other avionics systems.

The AEROSAT VHF avionics will most likely be installed on Boeing 747 and 727\* aircraft. Installation on other aircraft is still uncertain at this time.

The only VHF AEROSAT antenna installation which is adequately defined so far is that of the BOEING 747. This aircraft has therefore been selected as the basis for this EMI analysis. However, the methods used in the Bendix study for computing EMI are universally applicable and can be applied for any aircraft once the antenna location has been selected or once a measurement has determined the mutual R.F. coupling with other aircraft antennas.

The heart of the airborne terminal is the new Bendix RTA-43A Transciever modified for the specific requirements of the AEROSAT program. Details of this equipment are presented in Section 3.0.

At the time of this writing the particular type of MODEM to be used for VHF AEROSAT has not been determined as yet. The airborne terminal has therefore been designed to interface at a standard frequency of 70 MHz so that commonality can be achieved with future L-Band AEROSAT MODEMS.

Because of the lack of EMI data on MODEMS, BENDIX has conducted interference tests on BELL AEROSPACE and MAGNAVOX MODEMS. The results are summarized in Table 13.1.

An examination of Table 13.1 indicates that -8 dB is a valid worst case reference level for "ON CHANNEL" voice interference. The situation would be approximately 4 dB better for 1 kHz tone interference if a MAGNAVOX MODEM were used.

\*FAA Test Aircraft.

TABLE 13.1. INTERFERENCE LEVELS OF BELL AND MAGNAVOX MODEMS

DESIRED SIGNAL MODULATION	VOICE			DATA 1200 BPS			
	ON CHANNEL	25 kHz OFF	VOICE ON CHANNEL	VOICE 25 kHz OFF	ON CHANNEL	VOICE TONE (1 kHz, 90% MOD) 25 kHz OFF	
INTERFERENCE	-5 dB	+90 dB	-6 dB	+75 dB	-5 dB	+88 dB	
	0 dB (ΔMOD)	+75 dB (ΔMOD)					
BELL MODEM							
MAGNAVOX MODEM	-5 dB	+70 dB	-8 dB	+72 dB	-12 dB	+52 dB	
REMARKS	QUANTITATIVE TESTS						INTERFERENCE REFERENCE POINT: ERROR RATE = 10 <sup>-5</sup>
							Q - M/PSK

NOTE: TEST FREQUENCY: 126.5 MHz  
C/NO = 43 dB Hz

With an AEROSAT receiver bandwidth of 25 kHz the noise power for a system noise temperature of 1100 K is:

$$\begin{aligned} P_N &= K \cdot T \cdot B = 1.38 \cdot 10^{-23} \cdot 1100 \cdot 25 \cdot 10^3, \\ &= 3.8 \cdot 10^{-16} \text{ watts.} \end{aligned}$$

This is equivalent to:

$$10 \cdot \text{Log } 3.8 \cdot 10^{-16} = -154 \text{ dBW.}$$

The specified VHF AEROSAT downlink carrier to noise ratio is 43.5 dB Hz. For a 25 kHz bandwidth it becomes:

$$43.5 \text{ dB Hz} - 10 \log 25 \cdot 10^3 \approx -0.5 \text{ dB.}$$

This corresponds to a nominal signal level of:

$$-154 \text{ dBW} - 0.5 \text{ dB} = -154.5 \text{ dBW.}$$

The worst case ON-CHANNEL interference reference threshold is therefore:

$$-154.5 \text{ dBW} - 8 \text{ dB} = -162.5 \text{ dBW.}$$

This level has been used for the INTRA-AIRCRAFT EMI studies. As soon as the actual type of MODEM has been specified for the VHF terminal the numbers listed in this report can be corrected to reflect the actual interference threshold associated with the final configuration.

The avionics equipment installed in the Boeing 747 is listed in Table 13.2. Equipment which obviously need not be considered in this EMI analysis has not been included in this table. The inertial navigation and flight control equipment, selective calling, and audio systems fall into this category.

The antenna locations for all systems listed in Table 13.2 are shown in Figure 13.1.

A cursory review of Table 13.2 indicates that the only equipments that could conceivably cause AEROSAT receiver interference due to harmonic or nonharmonic radiations are the H.F. and VHF transceivers.

TABLE 13.2. EXISTING BOEING 747 AVIONICS

EQUIPMENT	ARINC CDAR.	FREQ. RANGE (MHz)	SCTE RANGE FOR (°)	TRANSMITTER		RECEIVER				ANTENNA	MODULATION	REMARKS
				MAIN ANTEN. dB	NOV. BAW. SPKR. ANTEN. dB	SENSITIVITY dBm	SENS. BANDWIDTH MHz	SPUR. REJ. CR	CLASS. SPACING kHz			
H.F. Transceiver	5335	Approx. 2-30	400	40	50	1.07 10 dB S+N	2.0 (75B) 5.5 (60V) 6.0	80	1	28,000	AM/FSK	Dual
Weather Radar	547	75	N/A	N/A	N/A	-91	22 (3 dB)	60	N/A	1	AM	Single
VHF Receiver	537	Approx. 108-118	N/A	N/A	N/A	-140 (6 dB)	34 (6 dB)	80 (Overall) 100 (in Band)	50	200	AM	Dual
Receiver Five	547	Approx. 108-112	N/A	N/A	N/A	-120 (6 dB)	74 (6 dB)	80 (Overall) 100 (in Band)	50	20	AM	Dual
VHF Air Ops Receiver	5456	Approx. 118-136	25	50	80 (Overall) 110 (in Band)	-130 (6 dB)	30/13 (5 dB)	80 (Overall) 100 (in Band)	25	720	AM	Dual
UHF Receiver	547	Approx. 329-335	N/A	N/A	N/A	-117	42 (3 dB)	80	150	40	AM	Dual
UHF Receiver	5310	960-1215	500-2000 3.2 (AT)			-120	100 (3 dB)	67	1000	232	P <sub>o</sub>	Dual
UHF Receiver	5320	1030 Rr 1090 Tr	500-1000	50		-104	60/0 (3 dB)	60 Below MCL	6000	1	P <sub>o</sub>	MCL = Min. Trig. Level Dual
Receiver	552	4250-4350	0.5	70	70	-118	207 (3 dB)	60 Assumed	N/A	1	FM/CM	Dual
Weather Radar	566	5150-5473 or 9121-9195	20,000 to 30,000			-137	500 (3 dB)	60 Assumed	N/A	1	P <sub>o</sub>	300 SW Range Dual
Automatic Direction Finder (ADF)	550	190-1550 kHz	N/A	N/A	N/A	70 uV/m	4 (5 dB)	90	N/A	N/A	AM	Dual

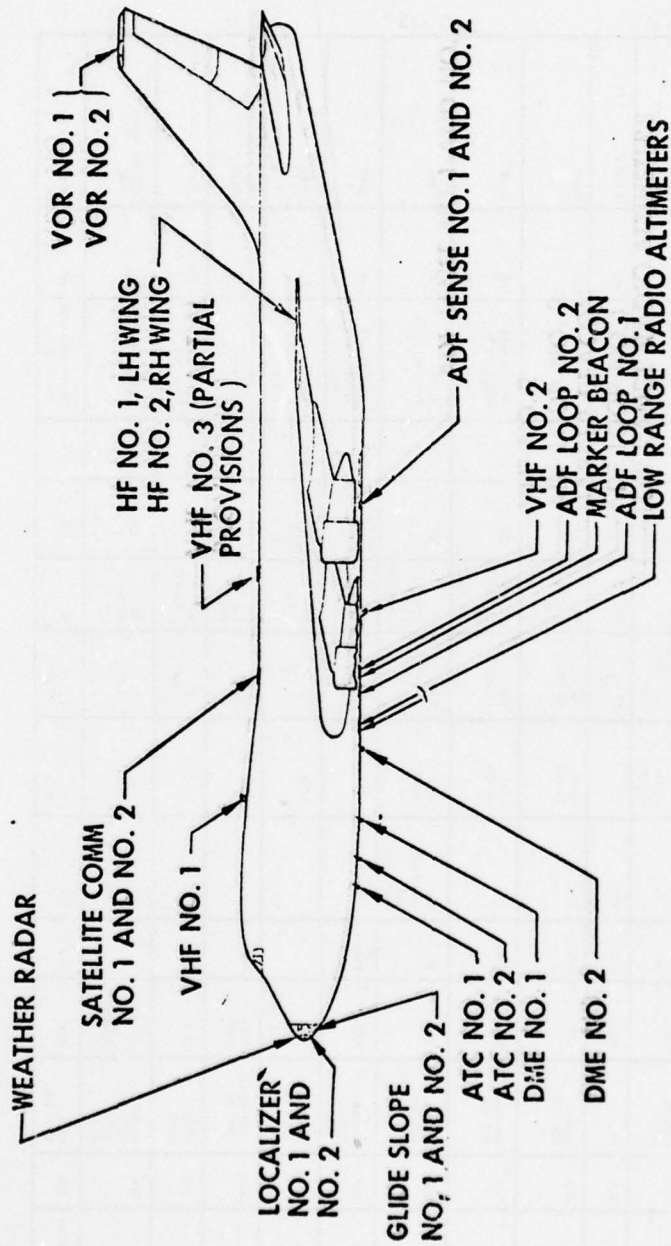

FIGURE 13.1. BOEING 747 ANTENNA LOCATIONS  
 FROM BOEING SALES BROCHURE

The AEROSAT transmitter, on the other hand, could conceivably cause interference in a number of airborne receivers due to harmonic and spurious radiation. The receivers in question are shown in Figure 13.2.

The Bendix study of electromagnetic interference between the Boeing 747 COM/NAV/RADAR Avionics and the VHF AEROSAT transceivers essentially confirmed the previous analysis made by ECAC. A summary of these Bendix findings appears in Table 13.3.

Intra-aircraft interference can definitely be expected between the VHF air-ground transceivers and the AEROSAT transceivers. Potential interference also exists between the H.F. transmitter and the low noise AEROSAT receiver. The potential intra-aircraft interference is critically dependent on the AEROSAT antenna and on other antenna locations. For all aircraft smaller than the Boeing 747 this interference will therefore be generally more severe than that predicted in this report.

The potential interference could become even more severe than predicted if the DORNE & MARGOLIN antenna is used because of its improved low angle antenna pattern.

Bendix concurs with previous findings that Terrestrial VHF ground facilities cannot use the same frequencies as AEROSAT.

The full duplex AEROSAT configuration selected as the preferred choice entails a significant development risk because of the difficulty in achieving adequate transmitter receiver isolation.

In order to verify the conclusions of the Bendix study and those of previous studies by ECAC it is strongly recommended to conduct a thorough ramp and flight EMI test program after installing the AEROSAT equipment and prior to any large scale official AEROSAT test flights. Particular attention should be paid to HF and VHF terrestrial transmitter interference. In addition, possible AEROSAT transmitter EMI with the terrestrial VHF receivers should be measured. The results of these verification tests should then be used to restrict, if necessary, the use of certain HF/VHF channels during the AEROSAT flight test program.

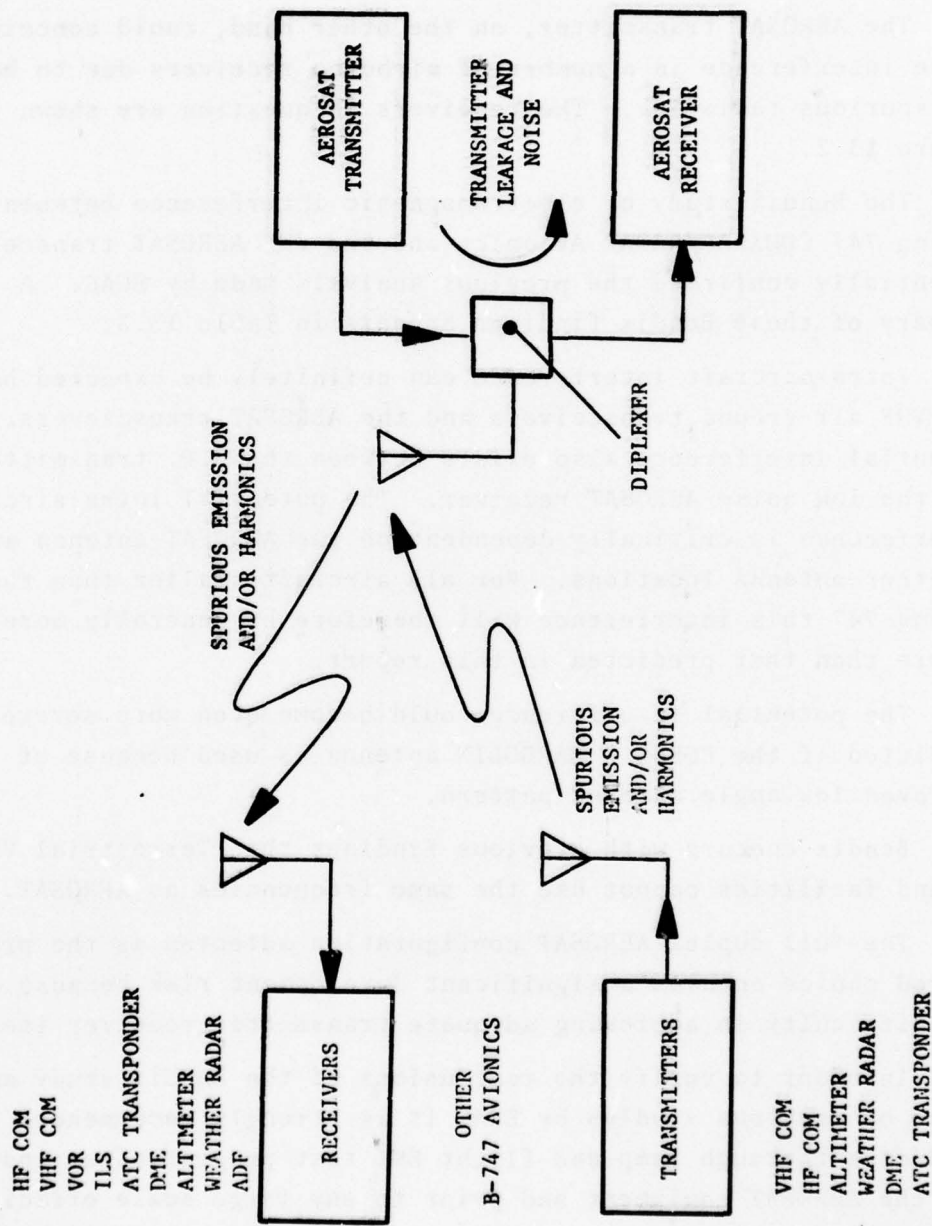

FIGURE 13.2 POTENTIAL INTRA-AIRCRAFT EMI

TABLE 13.3. POTENTIAL ELECTROMAGNETIC INTERFERENCE  
BETWEEN BOEING 747 AVIONICS AND VHF AEROSAT EQUIPMENT

EQUIPMENT	ARINC CHAR.	FREQ. RANGE (MHz)	AEROSAT RECEIVER	AEROSAT TRANSMITTER	REMARKS
H.F. Transceiver	533A	Approx. 2-30	Harmonics		Potential Operational Problem
Marker Beacon Rcvr.	547	75			No interference
VOR Receiver	547	Approx. 108-118		Spurious Emission	No Operational Problem
Localizer Rcvr.	547	Approx. 108-112			No Interference
VHF Air Gnd Transceiver	546A	Approx. 118-136	Spurious Emission	Spurious Emission	Potential Operational Problem
Glide Slope Rcvr.	547	Approx. 329-335			No Interference
DME Interrogator	521D	960-1215			" "
ATC Transponder	532D	1030 Rx 1090 Tx			" "
Radio Altimeter	552	4250-4350			" "
Weather Radar	564	5350-5470 or 9325-9395			" "
Automatic Direction Finder (ADF)	550	190-1750 kHz			" "

## 14. INSTALLATION

The VHF AEROSAT terminal, Figure 3.1, will most likely be installed in Boeing 747 aircraft. The original SLOT DIPOLE antennas designed in 1967 are still installed on many B-747 aircraft and retrofit is simple on those planes where the antenna has been removed because of weight considerations.

The VHF AEROSAT avionics equipment will probably be installed in the space originally allocated for the ARINC 566 SATCOM hardware. Figure 14.1 shows details of B-747 installations.

Table 3.2 contains a listing of estimated weights, dimensions and power consumptions of each unit of the VHF AEROSAT terminal. Interwiring is shown in Figure 14.2 to Figure 14.5.

The proposed VHF AEROSAT terminal equipment was designed to eliminate ARINC 404 type "A" cooling (forced air).

The antenna is the most critical component of the VHF AEROSAT equipment. It should be recognized that the original Boeing SLOT DIPOLE is not suitable for aircraft other than the B-747. Alternate antennas for B-747, DC-8, B-707, etc., are the BOEING CROSSED LOOP or the DORNE & MARGOLIN TURNSTILE antenna. For details on these antennas refer to Section 11.

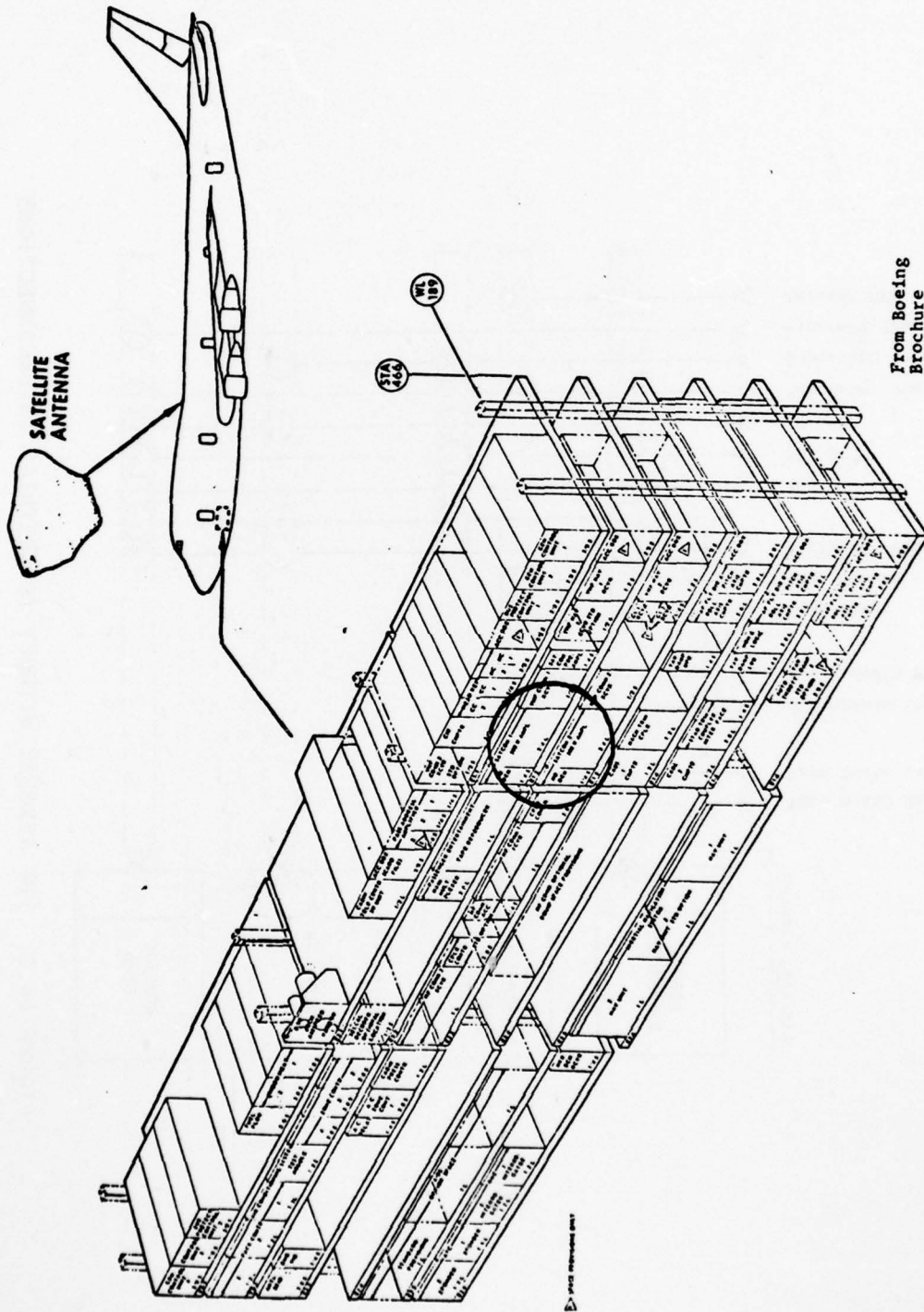

From Boeing Brochure

© MODRIP/DM

FIGURE 14.1. BOEING 747 MAIN EQUIPMENT CENTER

BEST AVAILABLE COPY

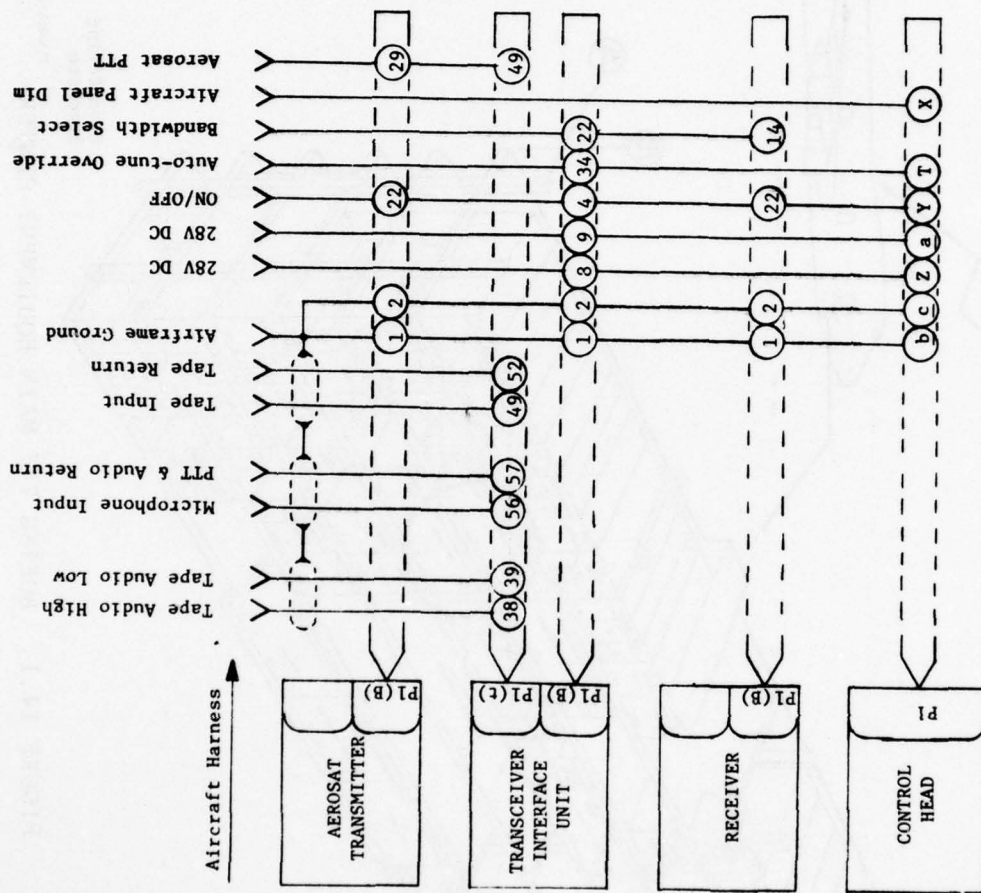

FIGURE 14.2. VHF AEROSAT WITHOUT TERRESTRIAL INTERCONNECTIONS

BEST AVAILABLE COPY

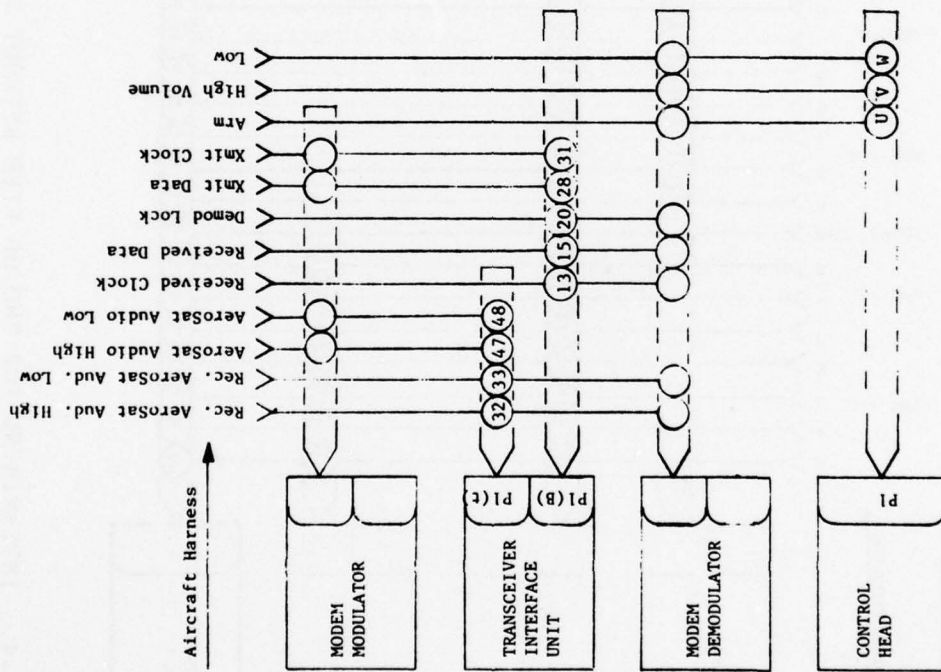

FIGURE 14.3. INTERWIRING WITHOUT TERRESTRIAL

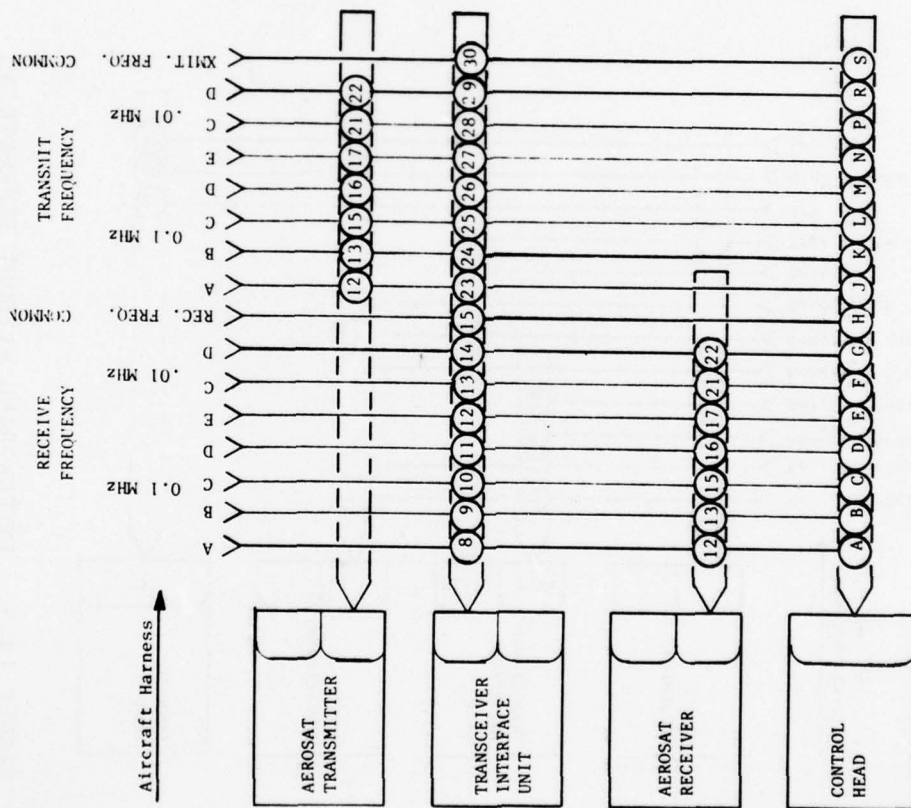

FIGURE 14.4. INTERWIRING FOR TWO OF FIVE WITHOUT TERRESTRIAL

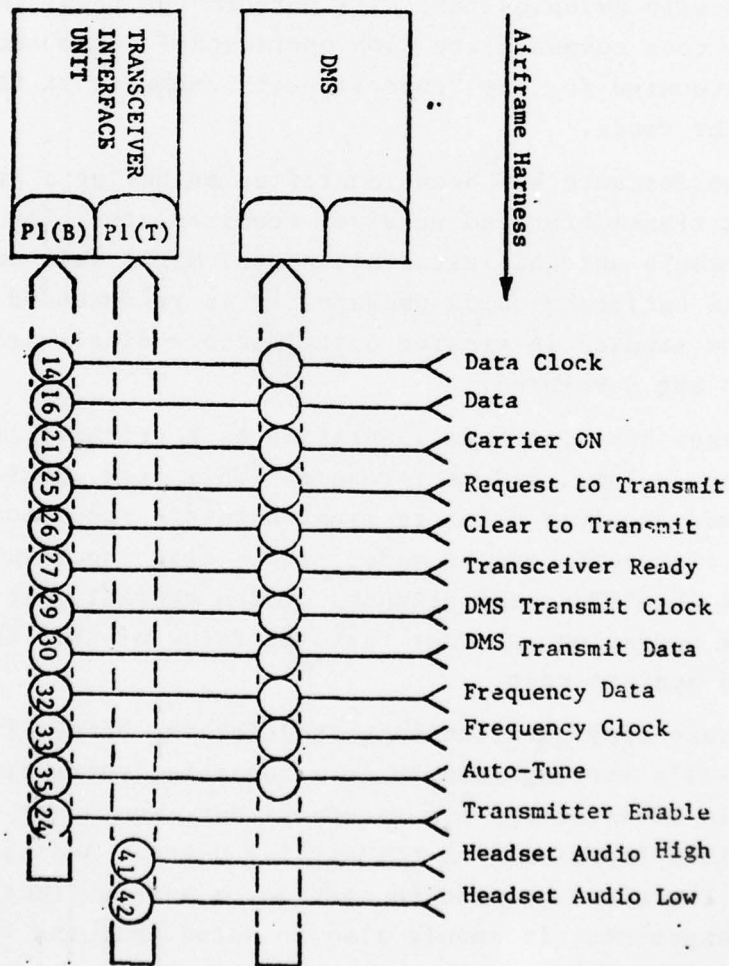

FIGURE 14.5 INTERWIRING FOR DMS TO TIU

## 15. CONCLUSIONS AND RECOMMENDATIONS

Earlier experiments by both Government and industry have shown that voice/data communications, and surveillance, via satellite, at VHF, are entirely feasible in a technical sense. The primary mission of the VHF portion of the current AEROSAT experiment should then be to develop the most reasonable and cost effective configurations of equipments to ultimately provide the user community with avionics that will perform the required functions at a cost commensurate with operational value received. This aspect accounted for the "retrofit kit" emphasis at the beginning of the study.

Antenna performance has been identified as having a pronounced impact on both transmitter and receiver requirements. For this reason, and because antenna installation cost might well outweigh the cost of the entire avionics package, it is recommended that this subject be studied in greater detail before final hardware specifications are developed.

The Diplexer has also been identified as a critical item as to cost, weight, volume, and performance. This item should therefore be procured and test prior to final hardware specifications so the proper trade-offs can be made. It is also important to be able to advise AEROSAT System planners of the overall cost impact of full duplex operation in order that the value of this feature can be weighed against cost.

The hardware configuration suggested for the Phase II experiment, two RTA-43's serving largely as a separate transmitter and receiver, while satisfactory for an experiment, would not make the best possible impression on the airline users. Additional effort should therefore be made to consider a more attractive packaging arrangement. It should also be noted that the 70 MHz modem interface, while convenient for the experiment and offering a relatively direct comparison with L-Band system performance, may not be optimum insofar as the VHF Avionics design is concerned.

AD-A053 206

BENDIX CORP FORT LAUDERDALE FL AVIONICS DIV  
VERY-HIGH-FREQUENCY AEROSAT AIRBORNE TERMINAL.(U)  
DEC 77 E O KIRNER, D KUNTMAN, J WILSON

F/G 22/2

DOT-TSC-1121

UNCLASSIFIED

FAA-RD-77-156

NL

2 of 2  
AD  
A053206



END  
DATE  
FILMED

6 - 78

DDC

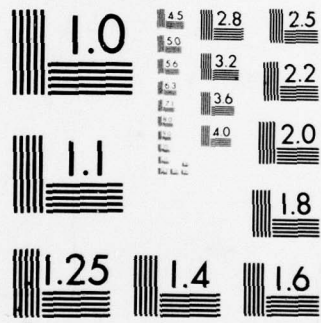

MICROCOPY RESOLUTION TEST CHART  
NATIONAL BUREAU OF STANDARDS-1963-A

The control panel arrangement discussed herein must also be considered as an "experimental" configuration. The final control head design should be determined after the conclusion of the AEROSAT test and evaluation program.

Finally, EMI analysis by ECAC and by the Bendix Avionics Division suggest that the interference potential in coastal areas might be one of the more critical areas affecting final frequency band choice.

## APPENDIX

### GLOSSARY

- AIRBORNE INHABITED** Airborne Inhabited is typical cockpit conditions without environmental extreme of pressure, temperature, shock, and vibration.
- AIRBORNE UNINHABITED** Airborne Uninhabited is a bomb-bay, wing or tail installation where extreme pressure, temperature, and vibration cycling may be aggravated by contamination from oil, hydraulic fluid, and engine exhaust.
- ELLIPTICITY** The ratio of the major axis to the minor axis of the polarization ellipse. Also known as axial ratio.
- FULL DUPLEX** The operation of associated transmitting and receiving apparatus concurrently, as in ordinary telephones, without manual switching between talking and listening periods.
- GAIN** In the frequency range where a dipole, or an array of dipoles, is a useful antenna gain, (G) is often given with reference to the gain of a dipole and expressed in decibels, dB. (The gain of a dipole is 2.15 dB above that of an isotropic radiator.)
- At higher frequencies, gain is most often given with respect to that of an isotropic radiator and expressed in dBi. Often this term is abbreviated to dB, thus leading to the possibility of confusion. Throughout this volume gain is given with respect to that of an isotropic radiator.

**GEOSTATIONARY SATELLITE** A satellite that orbits the earth from west to east at such a speed as to remain fixed over a given place on the earth's equator at approximately 35,900 kilometers altitude; makes one revolution in 24 hours, synchronous with the earth's orbit.

**GROUND FIXED** Ground Fixed is conditions less than ideal to include installation in permanent racks with adequate cooling and maintenance and possible installation in unheated buildings.

**HALF DUPLEX** The operation of associated transmitting and receiving apparatus with switching between talking and listening periods.

**NOISE TEMPERATURE** Noise temperature is expressed in Kelvin (K) or degrees above absolute zero ( $-273.15^{\circ}\text{C}$ ). [Kelvin, and therefore the symbol K, includes the concept of degrees, thus " $^{\circ}\text{K}$ " is redundant.]

## BIBLIOGRAPHY

Airborne Distance Measuring Equipment Mark -3, ARINC Characteristic No. 568, February, 1968.

Airborne HF SSB/AM System, ARINC Characteristic No. 533A, March, 1966.

Airborne ILS Receiver, ARINC Characteristic No. 578, May, 1970.

Airborne VHF Communications Transceiver and Mark 3 VHF SATCOM System, ARINC Characteristic No. 566A, August 23, 1972.

Airborne VOR Receiver, ARINC Characteristic No. 579-1, February, 1971.

Airborne Weather Radar, ARINC Characteristics No. 546-6, October, 1969.

Air Traffic Control Transponder Mar -2, ARINC Characteristic 572, September, 1968.

M.W. Alnutt et al., - "VHF Aircraft Antenna for Communication via Synchronous Satellite," Supplement to IEEE Transactions on Aerospace and Electronic Systems, Vol. AES-2 No. 4, July, 1966.

C.W. Amis, "An Intra-Aircraft EMC Analysis of AEROSAT Avionics Versus Present and Future Avionics Systems," ECAC Report, No. ECAC-PR-75-049, September, 1975.

Annex II to the Memorandum of Understanding, No. FAA-ED-17-2.

Boeing Slot-Dipole SATCOM Antenna, The Boeing Company Commercial Airplane Division, July 28, 1967.

J.M. Clarke et al., "Pulsed Interference Effects in a Phase Lock Loop," 1969 IEEE Electromagnetic Compatibility Symposium Record, June, 1969.

Effects of Terrestrial VHF Station on AEROSAT Return Link Performance, July 13, 1976.

EIA Standard RS-232-C, Electronic Industries Association, August, 1969.

EMC Analysis of the AEROSAT VHF Sub-system With Current In-Band Communications Systems, ITT Research Institute, Maryland, 1975.

Federal Aviation Work Statement for VHF Avionics Modifications for Use in the AEROSAT Program, Rev. 23 Attachment A, September, 1974.

J.W. Greiser, "Coplanar Stripline Antenna," Microwave Journal, Vol. 1, October, 1976.

Grant E. Hansell, Filter Design and Evaluation, Van Nostrand and Reinhold, 1969.

Ted Lerner et al., QM/PSK Voice/Data Modem Final Report, Bell Aerospace Corporation, March, 1976.

Hybrid Modem #1 Final Report, Bell Aerospace Co., February 1974.

International Radio Consultative Committee, XII the Plenary Assembly, Vol. 4 Part 2, New Delhi, 1970.

Modem Tests, Bendix Avionics Division, Technical Note #12, October, 1976.

Tryggi Olson et al., "L-Band Orthogonal-Mode Crossed-Slot Antenna and VHF Crossed-Loop Antenna," Report No. DOT-TSC-NASA-72-2, August, August, 1972.

Place Final Report, Bell Aerospace Co., June, 1970.

S.B. Poritzky, "New Electronics for Old Airplanes," A & A Forum, October 13, 1976.

J. Pries, "Evaluation of EMC Aspects of AEROSAT VHF Avionics Work Statement," ECAC report # ECAC-PR-75-005, June, 1975.

J. Pries, "Evaluation of EMC Aspects of the Specification for the US 1/2 Aeronautical Services Earth Terminal," ECAC report #ECAC-PR-75-029, June, 1975.

A.J. Viterbi, Principles of Coherent Communications, McGraw-Hill, 1966.

Watkins-Johnson, Application note #100393A, July, 1973.

Watkins Johnson Co., Technical Notes Vol. 3, No. 4, 1976.

190 copies