

AD-A053 374

AIR TRAINING COMMAND RANDOLPH AFB TX DIRECTOR OF OPE--ETC F/6 1/3  
ALTERNATIVES FOR FUTURE UNDERGRADUATE PILOT TRAINING, (U)  
APR 77 S G JOSEPH

UNCLASSIFIED

77-1

NL

1 of 3  
AD  
A053374



AD A053374



AU NO.

JDC FILE COPY

2

ALTERNATIVES  
FOR  
FUTURE UNDERGRADUATE  
PILOT TRAINING

**OPERATIONS  
ANALYSIS**

D D C  
RECEIVED  
MAY 2 1978  
A

**Air Training Command**

DISTRIBUTION STATEMENT A  
Approved for public release;  
Distribution Unlimited

6  
ALTERNATIVES FOR  
FUTURE UNDERGRADUATE PILOT TRAINING

Operations Analysis

Report No. 77-1

12 263p.

10 Steven G. / Joseph

DDC  
RECEIVED  
MAY 2 1978  
RECEIVED  
A

11 APR 15 1977

DISTRIBUTION STATEMENT A  
Approved for public release  
Distribution Unlimited

CAPTAIN STEVEN G. JOSEPH  
Operations Analysis  
Headquarters Air Training Command

414 302 full

ABSTAINER

This publication reports the results of an Operations Analysis study. It does not necessarily represent the opinion or policy of the Air Training Command or the United States Air Force.

UNIT	GROUP	CLASS
TYPE	CLASS	DATE
DATE	CLASS	DATE
CLASS	CLASS	DATE
<i>Letter on file</i>		
CLASSIFICATION CODES		
CLASS. BY SPECIAL		
A		

## SUMMARY

In July 1976, General William V. McBride, AF/CV, requested that <sup>The</sup> Air Training Command <sup>was requested to</sup> develop and examine alternatives for replacement of the aging T-37 along with options which provide a more economically trained graduate. (Reference Appendix A). This study reports the results of that examination.

### Requirement

Based on projected flying rates the T-37 fleet will be insufficient to sustain production by FY 88. The distribution of T-37 airframe hours dictates an Initial Operating Capability (IOC) of 1986 for the selected new aircraft.

However, these dates are subject to significant change should there be any substantial increases in programmed flying time due to additional programs or other changes. Examples of this type include NATO Joint Jet Pilot Training or expanded Copilot Enrichment (ACE); possible sale or transfer of existing aircraft resources; or reduced rate of displacement of aircraft hours by Instrument Flight Simulators (IFS) in non-UPT programs such as Instrument Pilot Instructor School (IPIS) or Security Assistance Pilot Training (SAPT). Any of these, if initiated, will accelerate fleet insufficiency and reduce the available lead time.

The length of the aircraft acquisition cycle (up to 11 years) demands that planning should begin as early as possible.

Current and projected future manned aircraft weapons systems characteristics and capabilities were reviewed to determine their impact on future pilot training, aircraft performance, and equipment requirements. This review indicated that technological advances will lead to many improvements in the performance characteristics of future aircraft. Modern avionics and flight data computers will further automate or assist with various pilot tasks and functions. However, it was concluded that the need to acquire basic flying skills is relatively unchanged since future pilots will still need to revert to basics should these advanced systems fail in combat or due to equipment malfunction.

Detailed future undergraduate pilot training (FUPT) requirements were thoroughly developed in the Mission Analysis (Reference 1). These requirements were again studied and validated in the Generalized/Specialized (Dual Track) Study (Reference 2).

A review of these pilot training requirements in view of future manned weapon systems leaves previously well documented training requirements largely intact with only

very minor modification. The Spin Recognition and Recovery requirement was combined with the Stall Recognition and Recovery requirement and renamed Departure Recognition and Recovery. A new training requirement, Airborne Rendezvous, was added to reflect the increasing role of in-flight refueling or cell formation.

#### Alternatives

Numerous training system alternatives were studied and evaluated. Four systems were subsequently selected as candidates for detailed examination and consideration as described below:

(1) Option I - XT-1/T-38. This is a generalized UPT system with the XT-1 designed as a primary jet trainer replacement for the T-37. The T-38 would be retained as the basic phase trainer until it, too, required replacement.

(2) Option II - XT-2. This is a generalized UPT system with a single, all-through aircraft (XT-2) designed to replace both the T-37 and the T-38.

(3) Option IIIA - XT-3/XT-3/T-38. This is a specialized UPT system with a single new aircraft providing both multi-engine basic training for Tanker-Transport-Bomber (TTB) pilot candidates as well as primary phase training for all UPT students. The T-38 would be retained to provide basic training for Fighter-Attack-Interceptor-Reconnaissance (FAIR) pilot candidates. The

XT-3 would be designed with a minimum of three seats to provide TTB training and would be capable of aerobatic maneuvering for basic flight training

(4) Option IIIB - XT-1/XT-3/T-38. This is a specialized UPT system utilizing three aircraft, two of which are new. The XT-1 fulfills the primary trainer role as a T-37 replacement. The XT-3 is utilized as a TTB basic trainer. The T-38 is retained as a FAIR basic trainer.

Performance and equipment parameters, along with representative mission profiles, for each of the three new aircraft identified above (XT-1, XT-2, XT-3) were submitted to Aeronautical Systems Division (AFSC/ASD) for conceptual design and cost information. This concept design and cost data were used to rank order the four alternative UPT systems previously described.

Representative syllabi were designed for each alternative system and are depicted below (Fig. 1). In order to provide a valid basis for cost comparisons, syllabus hours were selected to produce graduates of approximately equal quality, regardless of the system. More specifically, these particular syllabi do not contemplate significantly reducing post-UPT training through increased UPT training.

Figure 1  
 CANDIDATE FUPT SYSTEMS  
Generalized



Specialized

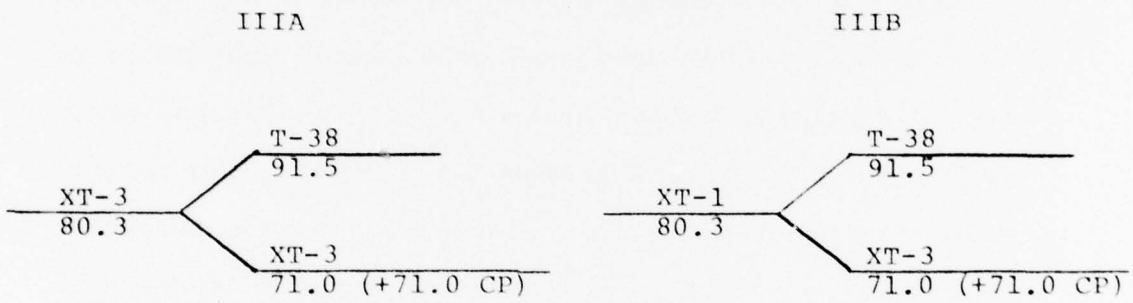

UPT Quality

The current UPT generalized training system is often viewed as being fighter-oriented due to its course structure and its use of the T-38 as a basic trainer. This is somewhat of a paradox when historically only about 40% of the UPT graduates have gone to fighter-oriented assignments while the other 60% go to TTB assignments.

The results of this analysis confirm those previously derived in the Mission Analysis, Mission Analysis Review (Ref. 3), and Generalized/Specialized studies. Quite simply, the specialized form of training is considered to provide a higher quality UPT graduate due not only to the added training requirements which can be taught, but because training is oriented toward a better transition into the follow-on training in CCTS.

From an operational aspect the specialized UPT systems have distinct advantages over generalized systems by producing graduates better trained in the skills and procedures required for their end assignment. Under a generalized pilot training system such broad training can result in overtraining of pilots in tasks unrelated to their end assignment. Furthermore, specialized UPT allows for greater flexibility in increasing or decreasing training time in pilot tasks in a given specialty or "track" without affecting the other track.

Specialized UPT does, however, have some drawbacks. Assignment flexibility, both in initial assignments and later career assignments, would be reduced. This does not appear to be an overly critical problem area. The greatest risk occurs in the initial acquisition of training equipment. Should the historical 60/40 split between TTB and FAIR assignments change dramatically (reverse, for

instance), then one incurs the risk of having insufficient FAIR trainer aircraft and an over-abundance of TTB trainers. The large size of the existing T-38 fleet tends to minimize this risk.

#### Costs

As developed for use in this study, all cost data are for relative rank ordering of alternatives only. Only system-dependent costs have been used; i.e., costs which did not tend to vary among system alternatives were disregarded.

Table 1 summarizes the more significant cost aspects associated with the various alternatives over a 23 year period (20 year aircraft life + 3 year development). Option 0 reflects costs associated with the current T-37/T-38 system under the projected IFS syllabus. It is provided here only for illustration purposes.

The outlays for research, development, test, and evaluation (RDT&E) plus acquisition costs are significantly less for Option IIIA, while the O&M costs are higher when compared to the other options. The least cost option lies with Option IIIB.

Table 1

SUMMARY COSTS  
(FY 77 CONSTANT \$M)

<u>OPTION</u>	<u>RDT&amp;E</u>	<u>IFS MOD</u>	<u>ACFT</u>	<u>TOTAL INVEST</u>	<u>O&amp;M</u> <sup>1</sup>	<u>TOTAL</u>
0 <sup>2</sup>	0	0	0	0	4702	4702
I (XT-1)	91	35	308	1394	3556	4950
(Repl. T-38) <sup>3</sup>	223	35	702			
II (XT-2)	223	68	1022	1313	3334	4647
IIIA (XT-3)	163	56	744	963	3601	4564
IIIB (XT-1)	91	35	308	970	3175	4145
(XT-3)	163	26	347			

<sup>1</sup> Does not include student and instructor pay or fixed operating costs.

<sup>2</sup> Option 0 provided for illustration purposes only. This is an impossible alternative since existing aircraft cannot be continued forever.

<sup>3</sup> T-38 would require replacement by 1995. XT-2 cost estimates used for T-38 replacement.

Another means of comparing the costs while trying to draw some distinction between options is the use of average annual value (AAV). The AAV, including acquisition, is provided in Table 2 for each alternative in constant FY 77 dollars, current (then-year) dollars, and discounted dollars. Also provided is the cost per USAF UPT graduate in FY 77 constant dollars which includes only the variable costs per graduate. Again, Option 0 is provided only as a frame of reference.

Table 2

	AVERAGE ANNUAL VALUE (AAV) - \$M			Cost per Graduate (FY77\$)
	<u>Constant (\$)</u>	<u>Current (\$)</u>	<u>Discounted (\$)</u>	
<u>0</u>				
T-37/T-38	204.443	762.751	234.953	.110
<u>I</u>				
XT-1/T-38	215.225 (4)	704.634 (4)	258.955 (4)	.102 (4)
<u>II</u>				
XT-2	202.023 (3)	623.167 (2)	249.164 (3)	.083 (2)
<u>IIIA</u>				
XT-3/XT-3/T-38	198.419 (2)	639.606 (3)	245.483 (2)	.086 (3)
<u>IIIB</u>				
XT-1/XT-3/T-38	180.229 (1)	573.291 (1)	223.907 (1)	.080 (1)

(Rank) -- lower number indicates lower cost

While it might be argued that the AAV and cost per graduate data in Table 2 are insignificantly different since nearly all are within 10% of each other, it is important to observe that the specialized Option IIIB is lowest in each case.

Fuel

Fuel costs and availability are of ever increasing concern. Table 3 summarizes fuel consumption rates for the various alternatives on a per graduate basis as well as for an annual UPT production rate of 2100 pilots. Option O (T-37/T-38) is again provided as a point of reference.

Table 3

OPTION	GAL/ GRAD (K)	ANNUAL CONSUMPTION (2100 UPT)		% REDUCTION FROM OPTION O
		GALLONS (M)	BARRELS (M)	
O	62.4	131.0	3.1	0%
I	47.6	100.0	2.4	24
II	23.5	49.3	1.2	62
IIIA	33.3	69.8	1.7	47
IIIB	27.4	57.5	1.4	56

The significantly lower fuel consumption rates for Options II, IIIA, and IIIB are due to replacement of the T-38 in whole (Opt II) or in part (Opt IIIA & B).

## Findings

The most effective pilot training system, both in terms of graduate quality and economic considerations, to replace the current system is a specialized UPT system utilizing the T-38 along with two new aircraft: a primary jet trainer (XT-1) and a basic TTB trainer (XT-3).

In studies of this type, a significant cost difference between options should arise if cost is to be a key discriminant upon which to base a decision. In the Mission Analysis, the difference in cost between options did not exceed 10%, well below the probable error normally expected in constructing "paper options" in such analyses.

In a subsequent update of the Mission Analysis specialized training was determined to be the most cost effective choice for FUPT. Results of both these studies were again confirmed in the Generalized/Specialized Comparison although other considerations led to a recommendation to continue generalized training.

Results of the most recent cost analysis used for this study show the specialized XT-1/XT-3/T-38 option to have the lowest cost on a relative rank ordering basis. While it is not clear whether significant cost differences exist between options for cost to be a key selection factor, it seems significant that this specialized option consistently results in lowest average annual cost (acquisition plus O&M) as well as lowest cost per graduate.

CONTENTS

ABSTAINER . . . . .	ii
SUMMARY . . . . .	iii
LIST OF FIGURES . . . . .	xvi
LIST OF TABLES. . . . .	xviii
ACRONYMS. . . . .	xx
I. INTRODUCTION. . . . .	1
II. APPROACH. . . . .	5
III. ASSUMPTIONS . . . . .	9
IV. FLEET LIFE. . . . .	17
Current Fleet Distribution. . . . .	17
Projected Fleet Life Expectancy . . . . .	20
V. FUTURE FORCE, AIRCRAFT, MISSIONS, AND PILOT SKILLS. . . . .	33
Future Force Missions/Aircraft. . . . .	33
Future Pilot Tasks/Skills . . . . .	35
VI. TRAINING REQUIREMENTS . . . . .	37
VII. TRAINING ALTERNATIVES . . . . .	45
Candidate FUPT Systems. . . . .	50
FUPT Aircraft Performance Requirements. . . . .	52
FUPT Aircraft Equipment Requirements. . . . .	55
FUPT Aircraft Maintenance Considerations. . . . .	55
Mission Profiles. . . . .	60
Syllabus Development. . . . .	66
Concept Designs . . . . .	68
Concept Cost Data . . . . .	69
Aircraft Production Requirements. . . . .	77
Phase-in Schedules. . . . .	79

VIII.	EVALUATION . . . . .	83
	Fleet Life Impact of New Systems . . . . .	83
	Training Requirements. . . . .	85
	Qualitative Assessment . . . . .	87
	Syllabus . . . . .	95
	Cost Analysis. . . . .	96
	Fuel Considerations. . . . .	105
	Additional Training Impacts. . . . .	107
	Sensitivity Analysis . . . . .	110
IX.	FINDINGS . . . . .	121
APPENDICES		
A.	USAF/CV LTR, 21 JULY 1976 AND RESPONSE. . . . .	A-1
B.	PROGRAMMED IFS SYLLABI. . . . .	B-1
C.	TRAINING REQUIREMENTS . . . . .	C-1
D.	MISSION PROFILES. . . . .	D-1
E.	FUPT SYLLABI. . . . .	E-1
F.	COCKPIT SEATING CONFIGURATION . . . . .	F-1
G.	DYNAMIC OBSERVER CONCEPT. . . . .	G-1
H.	AIRCRAFT PRODUCTION AND PHASE-IN SCHEDULING . . . . .	H-1
I.	COST ANALYSIS . . . . .	I-1
J.	AIRCRAFT AND SIMULATOR COST ESTIMATES . . . . .	J-1
K.	PROJECT ORGANIZATION. . . . .	K-1

LIST OF FIGURES

<u>Figure</u>		<u>Page</u>
1	Candidate FUPT Systems . . . . .	vii
2	Approach . . . . .	6
3	T-37 Airframe Hour Distribution. . . . .	18
4	T-38 Airframe Hour Distribution. . . . .	19
5	T-37 Life Expectancy vs Aircraft Utilization Rate . . . . .	21
6	T-38 Life Expectancy vs Aircraft Utilization Rate . . . . .	22
7	T-37 Annual Flying Hours vs Production, Syllabus . . . . .	28
8	T-37 Insufficiency vs Annual Flying Hours. .	29
9	T-38 Annual Flying Hours vs Production, Syllabus . . . . .	30
10	T-38 Insufficiency vs Annual Flying Hours. .	31
11	Preliminary Training Alternatives. . . . .	47
12	Candidate FUPT Systems . . . . .	51
13	T-37 Replacement Aircraft - Sample Advanced Contact Mission. . . . .	62
14	XT-1 Candidate Design. . . . .	70
15	XT-2 Candidate Design. . . . .	71
16	XT-3 Candidate Design. . . . .	72
17	Profile View Comparison of Candidate Aircraft . . . . .	73
18	Aircraft Acquisition Costs . . . . .	75
19	Aircraft Required. . . . .	80

<u>Figure</u>		<u>Page</u>
20	Aircraft Phase-in . . . . .	81
21	Cost per Graduate Comparison (Variable Costs Only) . . . . .	104
22	Fuel Consumption Comparison . . . . .	106
23	T-38 Fleet Insufficiency (Post Phase-in). . .	112
24	Sensitivity of Costs Away from Baseline . . .	115
25	Aircraft Operating and Acquisition Costs per Graduate. . . . .	117

LIST OF TABLES

<u>Table</u>		<u>Page</u>
1	Summary Costs . . . . .	x
2	Average Annual Value (AAV) - \$M . . . . .	xi
3	Fuel Consumption. . . . .	xii
4	Flying Training Production Requirements . . .	14
5	Projected IFS Syllabi . . . . .	24
6	Projected Production in Equivalent UPT Students. . . . .	26
7	Sample Task Analysis. . . . .	40
8	Pilot Training Requirements Summary . . . . .	42
9	Performance Requirements. . . . .	53
10	Equipment Requirements. . . . .	56
11	T-37 Replacement Aircraft - Sample Advanced Contact Mission . . . . .	63
12	Maneuver Description - Advanced Contact Mission . . . . .	65
13	FUPT Syllabus Comparison (Sorties/Hours). . .	67
14	Aircraft Description. . . . .	74
15	Flying Hour Cost Summary. . . . .	78
16	T-37/T-38 Fleet Status. . . . .	85
17	Candidate System vs Training Requirements . .	88
18	Operational Aircraft Flying-Hour-Cost Factors (FY 1977 Dollars) . . . . .	97
19	Cost Breakdown - \$M . . . . .	100

<u>Table</u>	<u>Page</u>
20 Rank Ordered Cost - \$M . . . . .	103
21 Impact of Additional Training. . . . .	109
22 Aircraft Production Schedule . . . . .	H-3
23 Flying Hour Phase-in Schedule (XT-1/T-38). . . . .	H-6
24 Flying Hour Phase-in Schedule (XT-2) . . . . .	H-7
25 Flying Hour Phase-in Schedule (XT-3/XT-3/ T-38). . . . .	H-9
26 Flying Hour Phase-in Schedule (XT-1/XT-3/ T-38). . . . .	H-11

## Acronyms

A/C	Aircraft
ACE	Accelerated Copilot Enrichment Program
ANG	Air National Guard
AFRES	Air Force Reserve
ATC	Air Training Command
AVPOL	Aviation Petroleum, Oils, and Lubricants
BOS	Base Operating Support
CCTS	Combat Crew Training School
DO	Dynamic Observer
DOD	Department of Defense
ELEM	Equipment Life Expectancy Model
FAIR	Fighter-Attack-Interceptor-Reconnaissance
FGN	Foreign
FUPT	Future Undergraduate Pilot Training
FWQ	Fixed Wing Qualification
GAF	German Air Force
IFS	Instrument Flight Simulator
IP	Instructor Pilot
IPIS	Instrument Pilot Instructor School
ISD	Instructional Systems Development
LCA	Low Cost Aircraft
LIT	Lead-in Training
MO	Medical Officer

NJJPT	Nato Joint Jet Pilot Training
O&S	Operations and Support
PCS	Permanent Change of Station
PIT	Pilot Instructor Training
RDT&E	Research, Development, Test, & Evaluation
RTU	Replacement Training Unit
SAPT	Security Assistance Pilot Training
TAC	Tactical Air Command
TDY	Temporary Duty
TTB	Tanker-Transport-Bomber
UNT	Undergraduate Navigator Training
UPT	Undergraduate Pilot Training
UR	Utilization Rate

## I. INTRODUCTION

### Purpose

In July 1976, General William V. McBride, AF/CV, requested that Air Training Command develop and examine alternatives for modification or replacement of the primary jet trainer aircraft, the T-37, as it approaches the end of its design life (see Appendix A). This study reports the results of that examination.

In order to develop trainer aircraft options, it is necessary to determine, in some detail, the mission requirements for future Undergraduate Pilot Training (FUPT). In effect, the aircraft is merely a training aid, albeit fairly sophisticated and expensive. Thus the type of training provided the military pilot should not be determined by the trainer aircraft available; rather, the trainer aircraft (or any other tool) should be determined by the type of training and levels of proficiency desired.

### Background

In January 1972, a massive examination of the future role of Undergraduate Pilot Training (UPT) culminated in publication of the FUPT Mission Analysis, often referred to more simply as the Mission Analysis (Ref. 1). The purpose of the Mission Analysis was to examine in detail

the training requirements and training media necessary to accomplish the UPT mission in the 1975-1990 time frame. The most significant recommendations were as follows:

- a. Procure flight simulators to:
  - (1) Stretch the fleet life of the T-37 and T-38 aircraft by reducing student syllabus flying hours.
  - (2) Increase student quality through exposure to flight conditions not practically taught in the aircraft.
  - (3) Reduce operating expenses.
- b. Expand the use of multi-media instructional aids (training aids, films, sound-slide presentations, etc.).
- c. Restructure training syllabi in accordance with Instructional System Development (ISD) methods, i.e., part-task missions, task repetition, etc.
- d. Emphasize the role of instructor pilots (IP) as training managers.
- e. Screen and select pilot candidates through ground-based methods.
- f. Employ a total management concept where long range management of FUPT is given equal importance with near term management so that individual elements do not evolve at their own pace.

Although not all recommendations of the FUPT Mission Analysis have been fully implemented at this stage, a significant portion of that effort is still applicable today, in particular the various training requirements and performance and equipment requirements of future training aircraft which were considered during that analysis. Albeit production rate projections, inflation, and energy costs have changed significantly since publication of the Mission Analysis, it serves as a basis for this study.

In March of 1976, ATC/DO published a Comparison of Generalized vs Specialized pilot training, often referred to as the Dual Track or Tracking Study (Ref. 2). Although this study pointed out that a specialized or "dual-track" system could prove to be more cost effective than the current system, such a program would require the purchase or lease of numerous additional aircraft capable of fulfilling the Tanker-Transport-Bomber (TTB) training track. Considering the current austere funding environment, a changeover to a specialized pilot training system was not recommended for the current time period. An important aspect of the Dual Track study was the revalidation, by the major commands, of the training requirements identified by the Mission Analysis.

In response to the ATC/DO study, General McBride pointed out that, whether the UPT concept changes or not, the T-37 is beginning to approach the end of its design life of 15,000 hours and will become insufficient in number to sustain projected pilot production beyond FY 88. He requested that ATC examine the alternatives.

A study group was formed which included personnel from several DCSs in HQ ATC and the 3305th School Squadron. In addition, Mr. Jerry Estepp, ASD/XRP, directed the conceptual aircraft design efforts for this study. Organization of this project, key study team members, and other participants are shown in Appendix K.

This study seeks to determine the most effective means of training USAF pilots in the mid-1980s and beyond.

## II. APPROACH

A similar approach to that used in the Mission Analysis was followed in this study (Fig. 2). Since the primary purpose of this study is to identify and choose alternatives for UPT commensurate with fleet life insufficiency, the first task was to identify the time frame in which the T-37 and T-38 fleets will be insufficient in number to support projected future production requirements. This fixes the period of interest for which a new or replacement UPT system will be needed.

The second step then was to review the future force along with supporting aircraft/missions and associated pilot skills required to accommodate the mission aircraft assignments.

The third task was to identify the UPT training requirements which must be taught the fledgling pilot in order to safely enter advanced training in these mission aircraft.

Next, various training system options or concept alternatives were devised in a general manner (dual track, single all-through aircraft, etc.). System elements such as representative training mission profiles were then developed for determining aircraft size and configuration. Other elements, such as aircraft performance

Figure 2

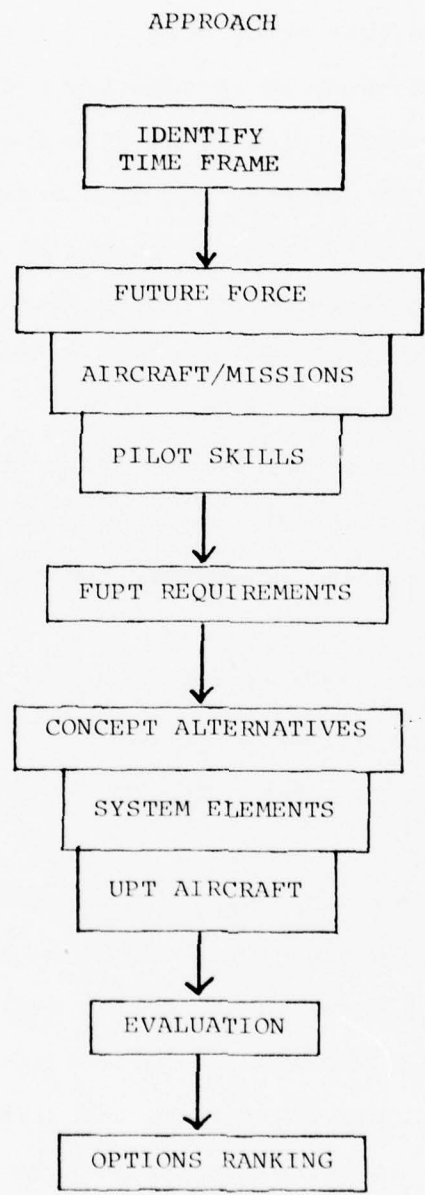

and equipment requirements, were developed to insure compatibility with training requirements and selected training systems. "Paper" airplanes were then designed which meet or exceed the desired characteristics. RDT&E and O&S costs were developed for these "paper" airplanes. Several costing techniques were then applied to the various training systems to determine the most cost effective alternative.

Considering the uncertainty in projections beyond five years for costs, pilot production levels, and other factors, parametric evaluation was made wherever feasible. A sensitivity analysis was performed as part of the evaluation process to determine relative ranking of FUPT options.

### III. ASSUMPTIONS

The assumptions presented in this section serve to limit and define the study. It is difficult to predict in detail the training needs of the future pilot force; therefore, certain assumptions become necessary. During the course of this study every attempt was made to minimize the adverse effects of assumptions which may later prove to be invalid, and a sensitivity analysis was made in the final evaluation. Assumptions used in this study are as follows:

Time Frame. A future UPT system would be phased in starting two or three years before insufficiency of the current fleet occurs, and would have a fleet life of 20 years thereafter. This is based on pilot production requirements, fleet insufficiency, aircraft production rates of 20 per month and 15,000 hours aircraft design life.

USAF Fixed Wing Training Only. This assumption purposely limits this study to a consideration of training for USAF pilots only. Helicopter training is not addressed. A joint service training program is also not considered at this stage. Although the possibility of a Congressionally-imposed joint USAF-Navy UPT is admitted, the additional complexities in syllabus design, etc., would require an extensive effort considered beyond the scope of this study.

Foreign programs, such as SAPT and NATO Joint Jet Pilot Training (NJJPT), are considered for computation of resources only. Syllabus design was not accomplished for each of these programs under each training alternative. Rather, flying hours are prorated on the basis of current syllabi when compared to the USAF UPT program.

CCTS Remain Operating Command Responsibility. Those training tasks and functions which require a coordinated crew effort with other than rated pilots (navigators, bombardiers, electronic warfare officers, loadmasters, etc.) will remain the responsibility of operating command CCTS. Likewise, training on or for mission specific and weapon system specific equipment will be accomplished in CCTS.

Some of the CCTS training can be accomplished within a specialized UPT training system, and to a lesser degree, in a generalized UPT system. Specifically, some tasks and/or functions which are taught in a post-UPT but pre-CCTS program such as TAC's lead-in training (LIT) could be accomplished in FUPT. Similarly, some post-UPT training currently conducted in CCTS is of a proficiency nature, such as increased training in low altitude approach procedures. This training is also considered appropriate for FUPT.

Simulation. The use of flight simulators as a major training medium will continue and probably increase during the time frame of this study. Air Training Command has recently purchased several Instrument Flight Simulators (IFS) for use in the UPT environment. At the time of this study, pilot training using these simulators had not yet begun, thus the degree of tradeoff between aircraft and simulator time has not been firmly established. Therefore this study restricts the use of simulation to instrument training only, as is envisioned for the current UPT/IFS program. The purchase of a new trainer aircraft will require purchase of simulator cockpits and necessitate reprogramming of the simulator computers. The number of cockpits requiring conversion is a function of the type of training system selected and syllabus design. The conversion costs are included in the cost analysis of the various system alternatives.

Purchase of a new mission profile simulator is not addressed during this study. However, the advances in simulation technology must be considered prior to final commitment to new aircraft. Acquisition of new simulators in addition to reconfiguration of the currently programmed IFS could reduce the size of buy of new aircraft, reduce syllabus flying hours, and possibly reduce costs.

Study Limited to Aircraft Considerations. This study recognizes the need for a thorough review of the total USAF flying training program to include, but not limited to, UPT, LIT, CCTS, ACE, RTU, proficiency flying, and continuation training. Such an examination is considered beyond the scope of this study. This study restricts itself to those areas conventionally considered in the realm of UPT; however, it is not constrained by UPT as it exists today.

A review of UPT training does not address in any great detail such peripheral, but admittedly important, items as computer-aided instruction, peer instruction, pilot and academic instructor training, ground-based screening and selection of pilot candidates, personnel policies, etc.

ATC to Conduct UPT. Air Training Command will continue to conduct basic flying training. The amount of training conducted by ATC will be a function of operational requirements, cost effectiveness, and commonality of pilot skills among the various weapons systems.

Aircraft Life. The currently recognized airframe life of the T-37 (15,000 hours) and the T-38 (16,000 hours) are used for all computations. Any follow-on trainer will be designed for a 15,000 hour life.

Production Level. This study assumes a USAF UPT production rate of 2100 pilots per year in 1982 and beyond. ANG, AFRES, SAPT, PIT, IPIS, and other programs are as depicted in Table 4, Flying Training Production Requirements.

German Air Force (GAF) aircraft and production requirements are excluded in this study. Mather AFB T-37 aircraft in support of Undergraduate Navigator Training (UNT) are also excluded.

Dollars Used as Index of Merit. Dollar costs used in this study are for measurement purposes only and are not budgetary. Dollar costs are used to show the relative differences in procurement and operating costs among selected training alternatives. It is assumed that the relative cost ranking of alternatives will be unchanged even though actual procurement and operating costs may differ significantly from those projected in this study.

Proven Technology. Trainer aircraft will be designed and built using proven technology. Although every new aircraft involves a certain amount of airframe and engine R&D, trainer aircraft, considering their limited operational role, do not appear to be appropriate vehicles on which to expend massive R&D efforts. From a training viewpoint, such items as display systems in advance of operational aircraft systems may even have a negative training impact.

Table 4

FLYING TRAINING PRODUCTION REQUIREMENTS \*

(DOES NOT INCLUDE GAF/MATHER/ACE)

<u>PROGRAM</u>	<u>77</u>	<u>78</u>	<u>79</u>	<u>80</u>	<u>81</u>	<u>82 ON</u>
<u>UPT</u>						
USAF	1225	1000	1000	1175	1700	2100
ANG/RES	90	92	92	92	92	92
FGN	57	59	59	59	59	59
<u>SATP</u>						
T-37	329	279	331	343	348	348
T-38	230	232	260	285	275	275
<u>PIT</u>						
T-37	323	243	260	342	340	340
T-38	283	247	283	383	363	350
<u>FIXED WING QUALIFICATION</u>	60	60	60	40	40	40
<u>KUWAIT (T-38)</u>	15					
<u>IPIS (T-38)</u>	262	251	251	250	250	250
<u>MED OFF (T-37)</u>	8	8	8	8	8	8

\* Based on PFT 78-3; AF/DPPTF Ltr, 4 Aug 76; Extended Planning Annex.

Aircraft Designed for Training Purposes Only. Only training requirements will be considered in aircraft design for purposes of this study. It is recognized that various operational capabilities may be desired and, in effect, required. Such items as aerial refueling capabilities, depressible gunsights, ordnance delivery ability, etc., should be addressed prior to actual procurement of a follow-on trainer aircraft. However, the inclusion of these considerations at this stage of concept formulation serve merely to complicate the process of selecting among training system alternatives without adding to the solution. For example, suppose the rank order of aircraft alternatives is A; B; C. Incorporating an aerial refueling capability in any of these options will add a relatively constant dollar cost, K, to each of these options, resulting in a rank order of A+K; B+K; C+K--the same rank order as previously established.

Once a particular training system is selected, it then becomes necessary to examine in detail the cost versus training benefit of various operational capabilities. At that point additional considerations such as use in ACE-type programs, other post-UPT training programs, mission capabilities, foreign sales, etc., impact significantly on final aircraft design and cost.

In summary, this study limits itself to aircraft performance and equipment design parameters considered necessary in selecting a desired training system for USAF UPT only.

New Procurement. For purposes of this study, procurement of new aircraft is envisioned. It is considered inappropriate as a part of this study for ATC to evaluate the myriad of existing or proposed trainer aircraft designs currently available from practically every major aircraft manufacturer, both foreign and domestic. In general an existing design could reduce initial RDT&E and acquisition costs but may incur significantly higher O&M costs which would offset the lower procurement costs on a life cycle cost basis. The evaluation of existing aircraft or proposed new aircraft to meet future UPT needs is only appropriate after a decision is made as to the nature (e.g., specialized or generalized) of future UPT.

Facilities. Existing physical facilities (hangars, ramp space, runways, warehouses, etc.) are considered capable of supporting future UPT systems.

Additional Assumptions. This section has listed the more significant assumptions to be used in the study. Numerous minor assumptions will be required throughout the report. These assumptions are contained in the appropriate section.

#### IV. FLEET LIFE

The current status of both the T-37 and T-38 fleet of ATC training aircraft was examined. Based on programmed production rates, syllabus hours, and aircraft attrition rates, a projected fleet insufficiency date was derived. T-37 fleet insufficiency is anticipated in FY 88 and T-38 insufficiency occurs six years later in FY 94.

##### Current Fleet Distribution

Figure 3 depicts the distribution of the T-37 fleet by flying hours as of 1 January 1977 with aircraft grouped in 100 hour increments. Not shown on this chart are 34 T-37 aircraft based at Mather AFB for support of UNT, and 45 T-37s based at Sheppard AFB, which are owned and maintained by the German Air Force (GAF). Similarly, Figure 4 depicts T-38 airframe hour distribution, and excludes the 41 GAF T-38s at Sheppard.

As of 1 January 1977, the average T-37 hours per airframe were 7,905 or slightly over half the design life of 15,000 hours. For the T-38, the average airframe hours were 5,488, or slightly over one-third of its design life.

FIGURE 3

T-37 AIRFRAME HOUR DISTRIBUTION  
AS OF 1 JANUARY 1977

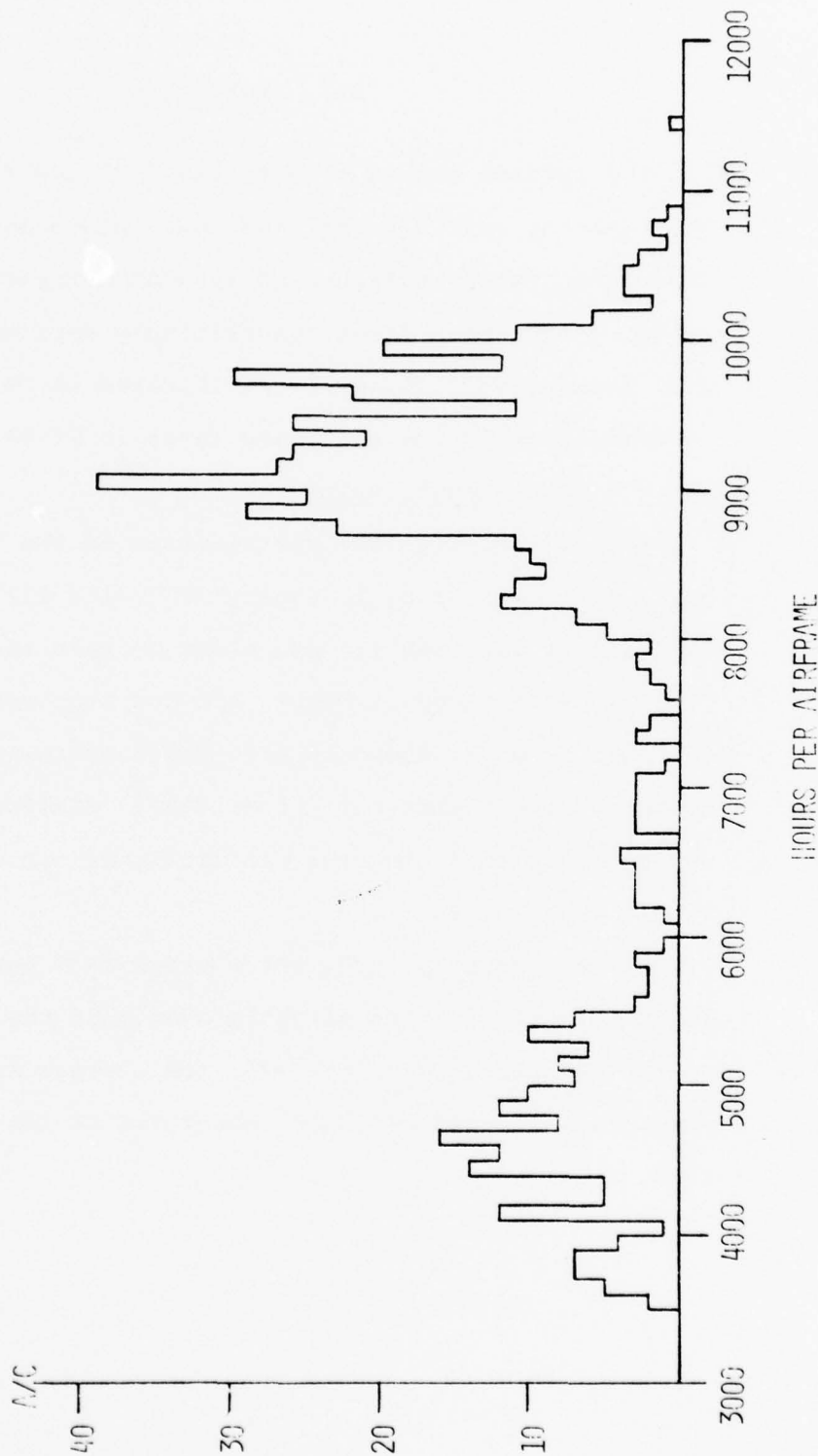
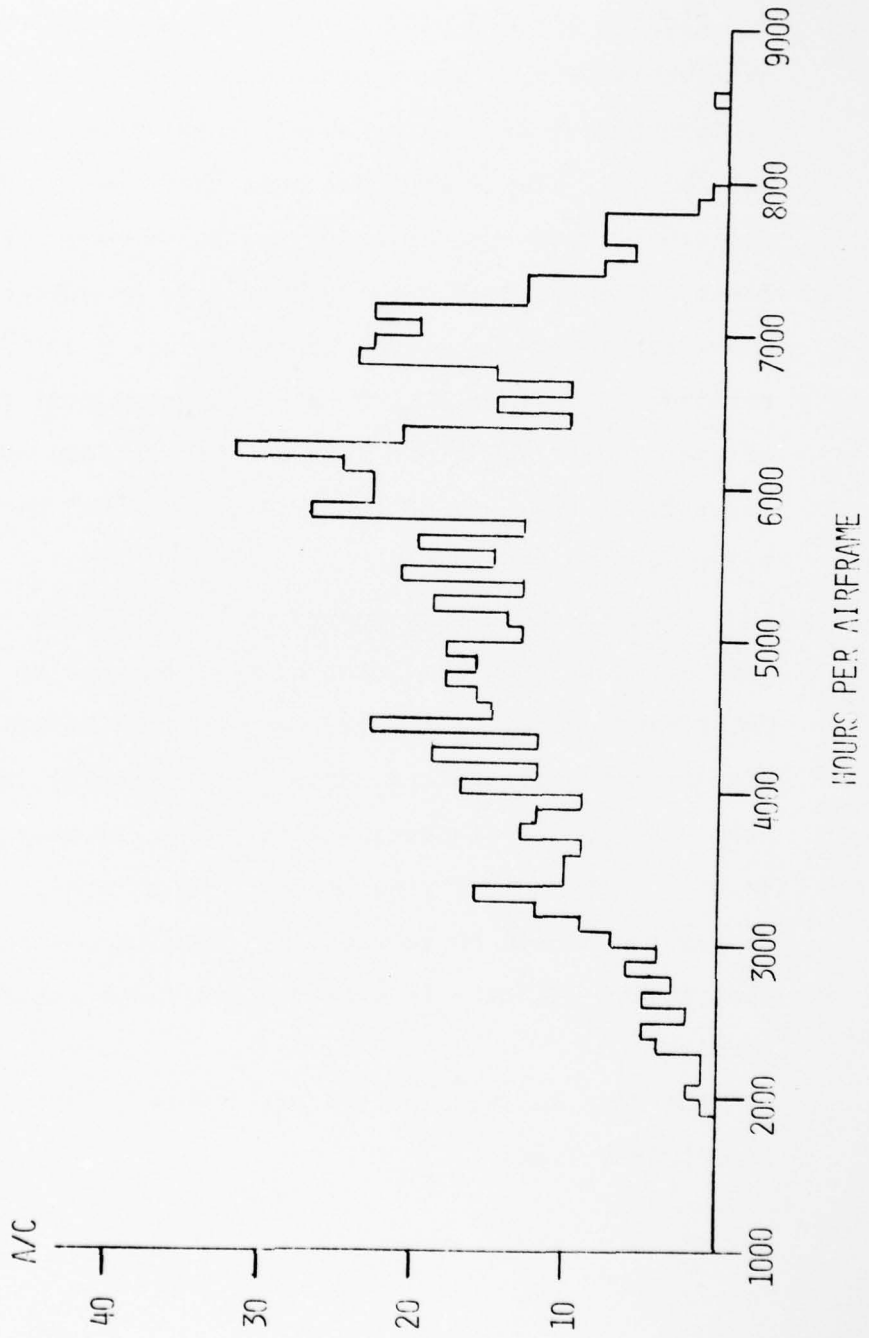

FIGURE 4

T-38 AIRFRAME HOUR DISTRIBUTION  
AS OF 1 JANUARY 1977



### Projected Fleet Life Expectancy.

Figures 5 and 6 plot fleet life expectancy versus utilization rate. These plots were developed using the Equipment Life Expectancy Model (ELEM) described in Reference 4. The ELEM model ages the fleet by evenly distributing the projected flying hours over the entire fleet. When aircraft reach their life expectancy (15,000 hours for the T-37, 16,000 hours for the T-38), they are retired and further flying is distributed over the remainder of the fleet. The fleet size is also reduced by attriting aircraft at the rate of one T-37 per 100,000 hours and two T-38s per 100,000 hours.

Fleet insufficiency occurs when there is at least one less aircraft than the total number required to train the programmed number of pilots. As shown in Figures 5 and 6, the aircraft utilization rates (UR) gradually increase, primarily due to aircraft attrition, until many aircraft acquire sufficient flying hours to be retired. This causes a dramatic UR increase for remaining aircraft such that the UR standard is exceeded and fleet insufficiency results.

The data and assumptions below were used for developing Figures 5 and 6:

T-37 LIFE EXPECTANCY

VS

AIRCRAFT UTILIZATION RATE

PFT 78-3, OCT 1976  
AF/DPPTF LTR, 4 AUG 1976  
EXTENDED PLANNING ANNEX

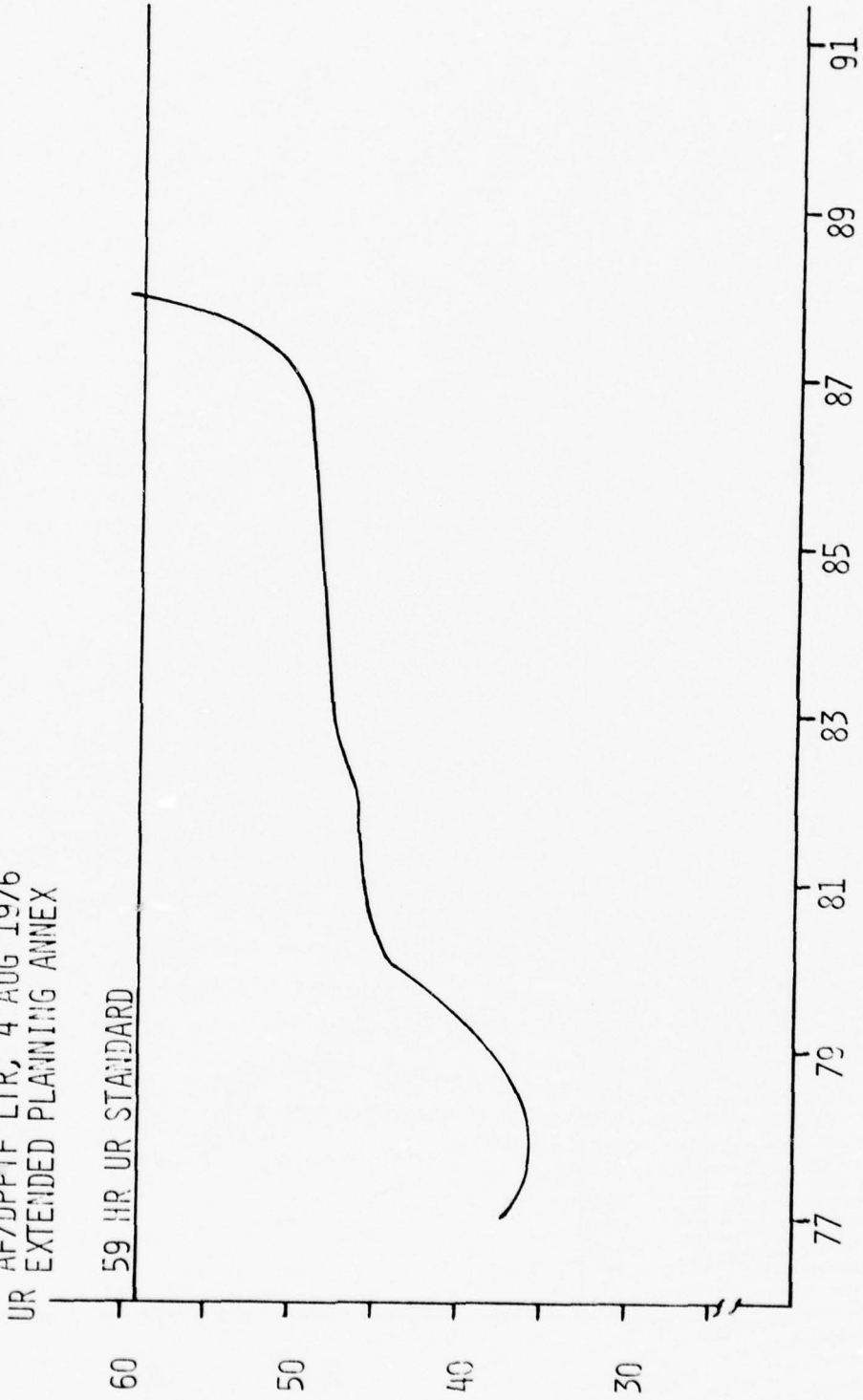

BEGIN FY

FIGURE 5

T-38 LIFE EXPECTANCY  
vs  
AIRCRAFT UTILIZATION RATE

PFT 78-3, OCT 1976  
AF/DPPTF LTR, 4 AUG 1976  
EXTENDED PLANNING ANNEX

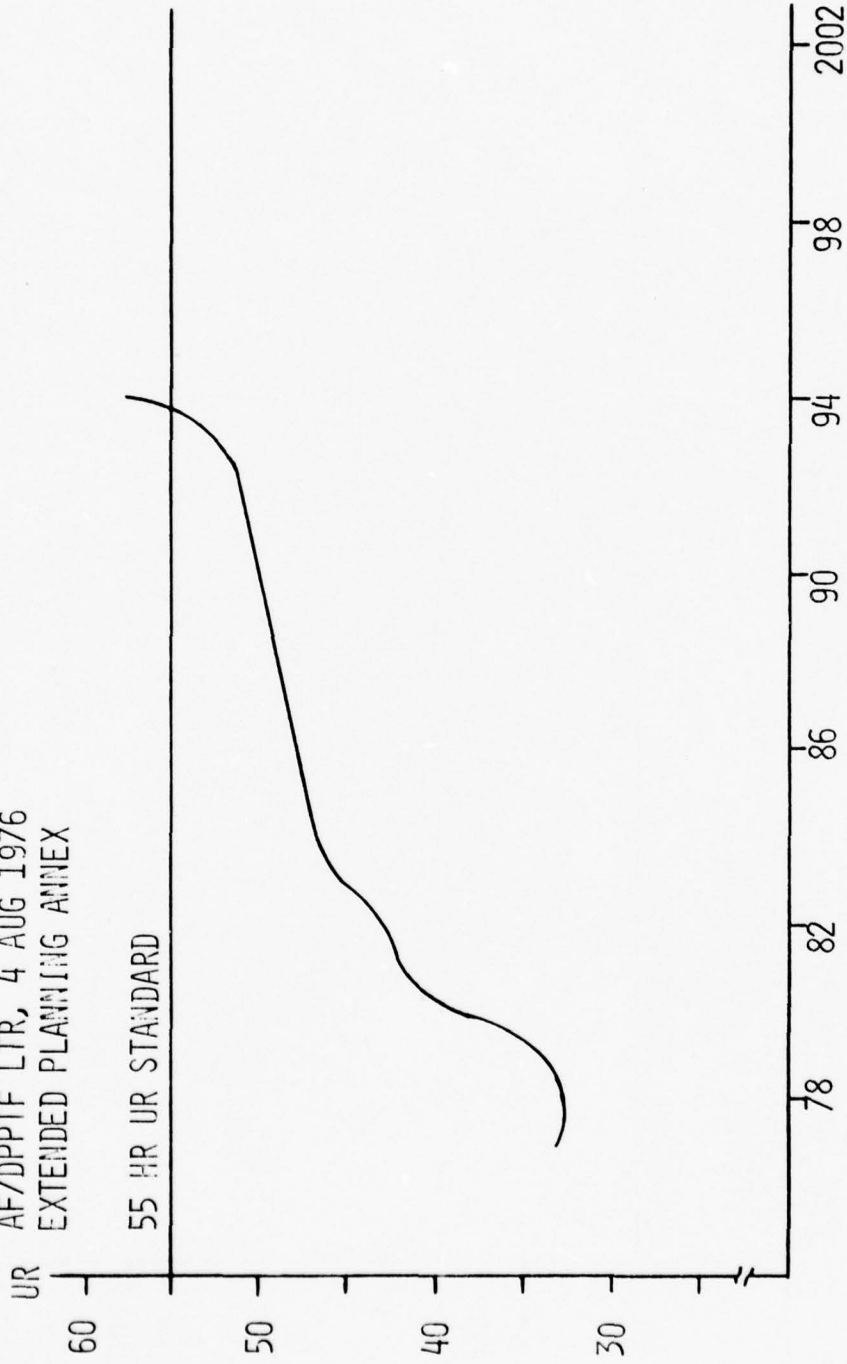

BEGIN FY

FIGURE 6

	<u>T-37</u>	<u>T-38</u>
Production	PFT 78-3, Oct 1976 AF/DPPTF Ltr, 4 Aug 76 Extended Planning Annex(EPA)	Same
Aircraft Life	15,000 Hrs	16,000 Hrs
Student Attrition	9.64%	4.32%
Maximum Utilization Rate	59.0 Hr/Month	55.0 Hr/Month
A/C Attrition Rate	1/100,000 Hrs	2/100,000 Hrs
Not Operationally Ready Rate	5%	5%
Syllabus Hours	71.8 Hrs/Stud	98.2 Hrs/Stud

Non-UPT flying programs, such as SAPT, PIT, etc., were equated to UPT programs in proportion to their flying hours and student attrition relative to the standard UPT program. The projected syllabi at Table 5 (expanded in Appendix B) were used for the conversion. Note that these syllabi incorporate the use of the Instrument Flight Simulator (IFS) and subsequently reduced flying hours. Should these programs not utilize the IFS, an increase in annual flying hours and shortened fleet life expectancy will result.

This example depicts the methodology used for conversion of non-UPT to UPT students. Given the following:

TABLE 5  
 PROJECTED IFS SYLLABI  
 (SORTIES/HOURS)

<u>T-37 PHASE</u>	<u>UPT</u>	<u>SAPT</u>	<u>PIT</u>	<u>IPIS</u>
Aircraft	55/71.8	105/137.2	36/49.4	---
Trainer	28/24.0	30/38.0	11/8.8	---
Simulator	31/35.2	30/38.4	19/24.0	---
<u>T-38 PHASE</u>				
Aircraft	78/98.2	78/98.2	45/55.8	10/13.0
Trainer	31/29.6	31/29.6	26/32.8	2/4.0
Simulator	37/38.4	37/38.4	10/8.0	13/17.2

	<u>SAPT T-37</u>	<u>UPT T-37</u>
Syllabus Hrs/Stud	137.2	71.8
Attrition Rate	9%	9.64%
Production	348	--

Then,

# Graduates (UPT equivalent) =

$$\# \text{ Grads (non-UPT)} \times \frac{\text{Syll Hrs (non-UPT)}}{\text{Syll Hrs (UPT)}} \times \frac{1-\text{Att (UPT)}}{1-\text{Att (non-UPT)}}$$

or, using the example:

$$\# \text{ Grads (Equiv)} = 348 \times \frac{137.2}{71.8} \times \frac{.9036}{.91} = 660$$

Using the above methodology, projected production rates in equivalent UPT students are depicted in Table 6.

Figures 7 through 10 provide fleet life data in a parametric form. For the T-37, enter the chart (Fig 7) with projected blue suit production (2,100 in example); continue up through equivalent students (3,246 in example); to the appropriate UPT syllabus hours per student (71.8); then across to annual T-37 flying hours (282,308 hours); then adjust for 30,588 additional flying hours in support of the ACE program to arrive at total annual flying hours (312,896). On Figure 8, enter at total annual flying hours (312,896); horizontally to the

TABLE 6  
PROJECTED PRODUCTION IN EQUIVALENT UPT STUDENTS  
 (FY 82 ON)

PROGRAM	T-37		T-38	
	ACTUAL	EQUIVALENT	ACTUAL	EQUIVALENT
UPT	2251	2353*	2251	2251
SAPT	348	660	275	277
PIT	340	216	350	198
F.W. QUAL	40	15	40	35
IPIS	--	---	250	32
MED OFF	<u>8</u>	<u>2</u>	<u>--</u>	<u>--</u>
TOTAL	2987	3246	3166	2793

\* Reflects T-37 production required to ensure T-38 production with attrition.

current fleet inventory curve; down vertically to projected fleet insufficiency date (FY 88). The curved lines, labeled -25 A/C, -50 A/C, etc., represent the effect of giving away (foreign sales, other programs, etc.) various multiples of 25 aircraft, over and above normal aircraft attrition or retirement. These aircraft (-25, -50, etc.) were considered removed in FY 82 for purposes of construction of these charts. Figures 9 and 10 provide similar data for the T-38 fleet.

The production levels through FY 81 in Table 4, based on PPT 78-3 (Ref 5), were used to develop these charts; thereafter (FY 82 on) annual flying hours are read from the vertical axes.

The slight negative slope of the lines on Figures 8 and 10 is due to the effect of accident attrition, the more sharply defined slope is due to the effect of aircraft retirement.

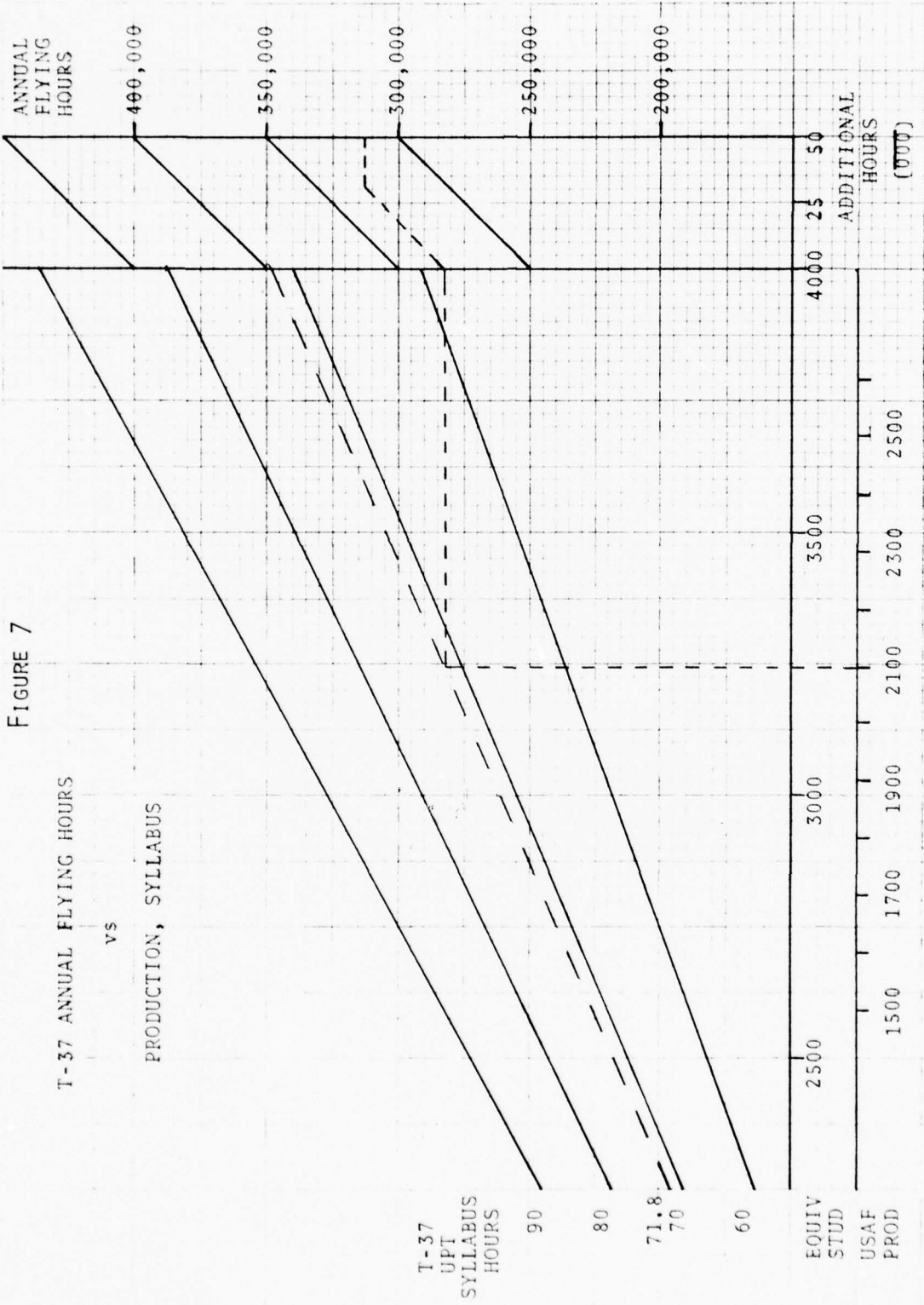

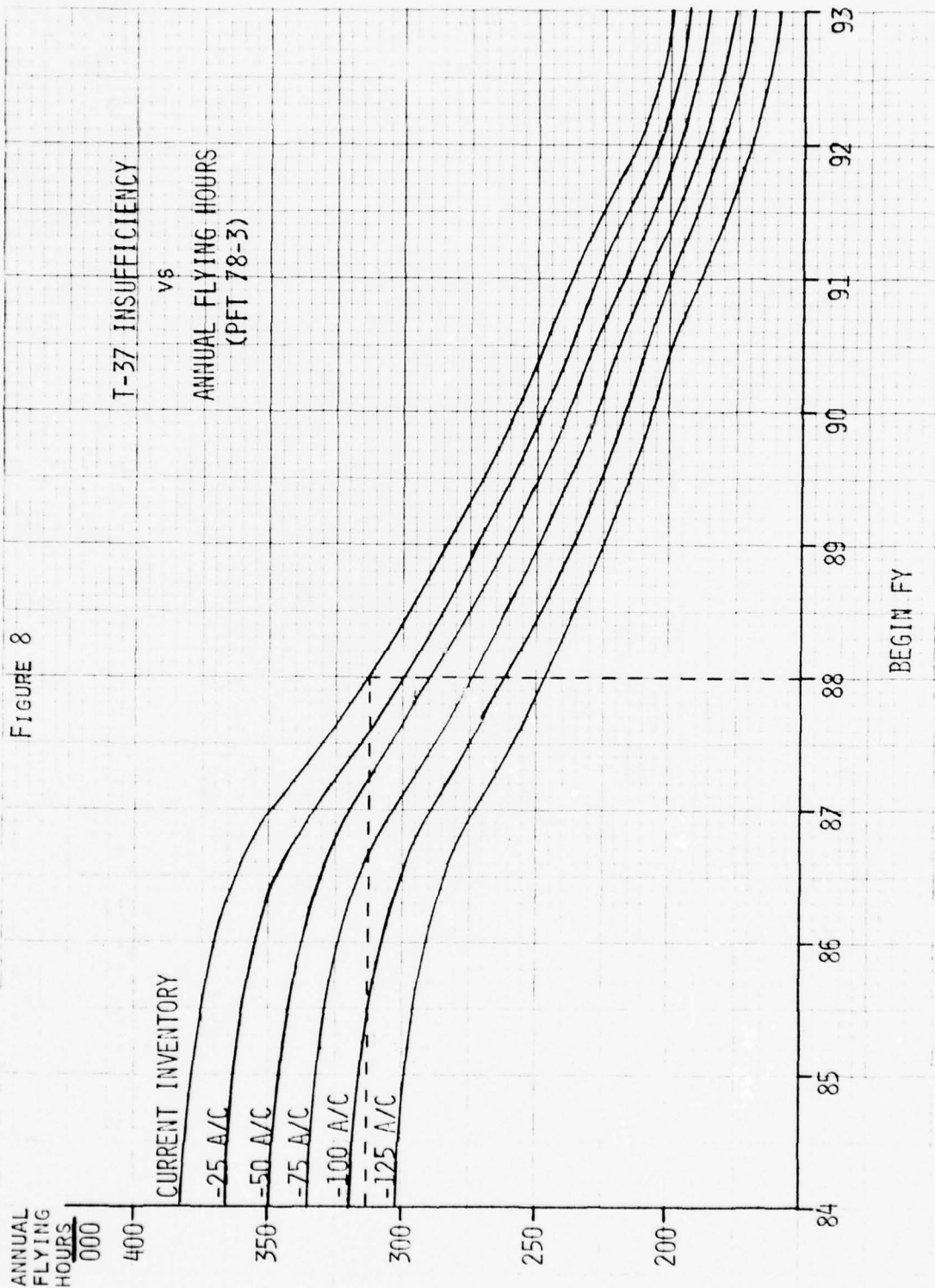

FIGURE 8

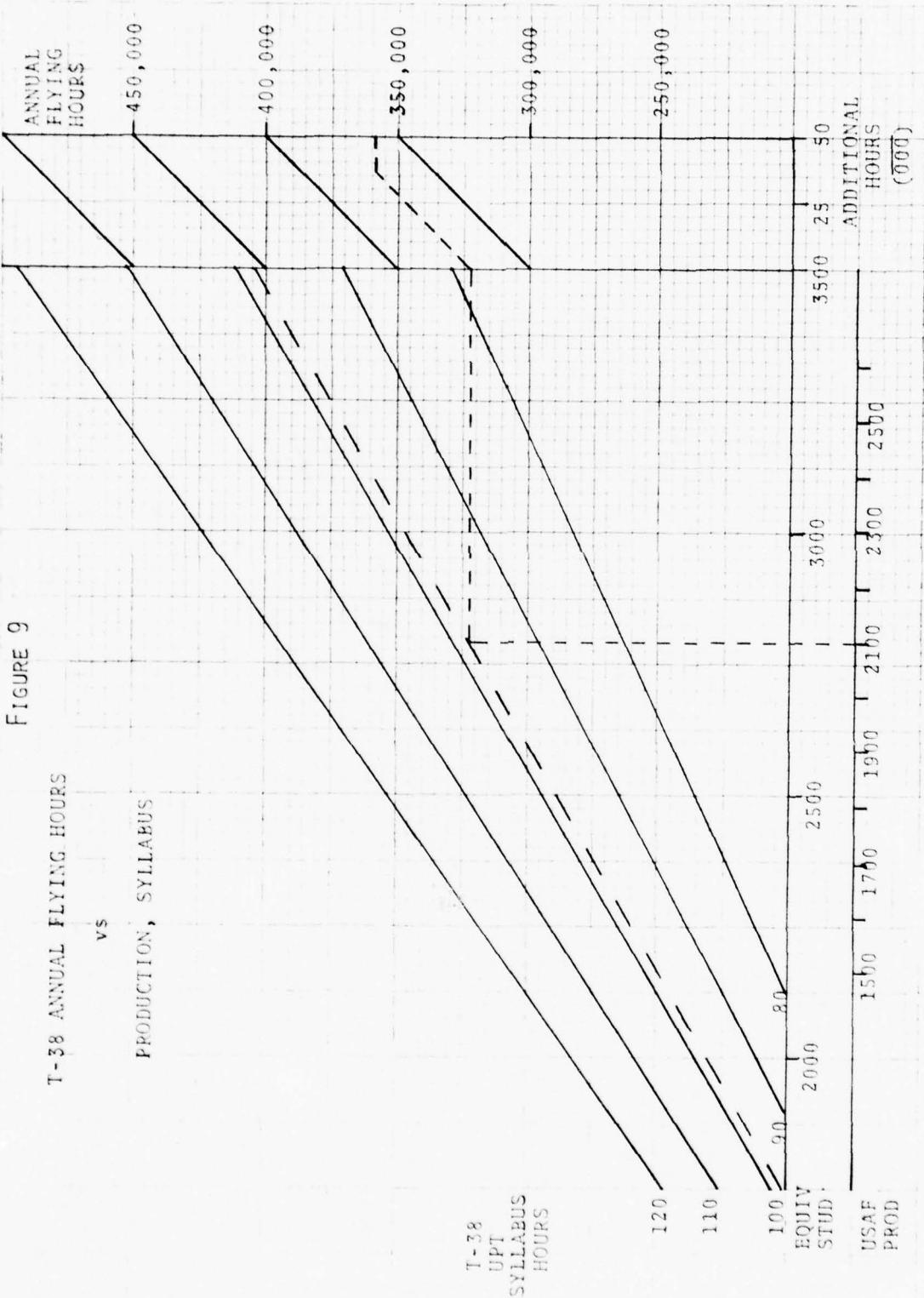

FIGURE 9

T-38 ANNUAL FLYING HOURS

vs

PRODUCTION, SYLLABUS

T-38  
UPT  
SYLLABUS  
HOURS

120

110

100

EQUIV  
STUD.

USAF  
PROD

ANNUAL  
FLYING  
HOURS

450,000

400,000

350,000

300,000

250,000

50  
25  
ADDITIONAL  
HOURS  
(000)

3500

2500

2300

2100

1900

1700

1500

2000

80

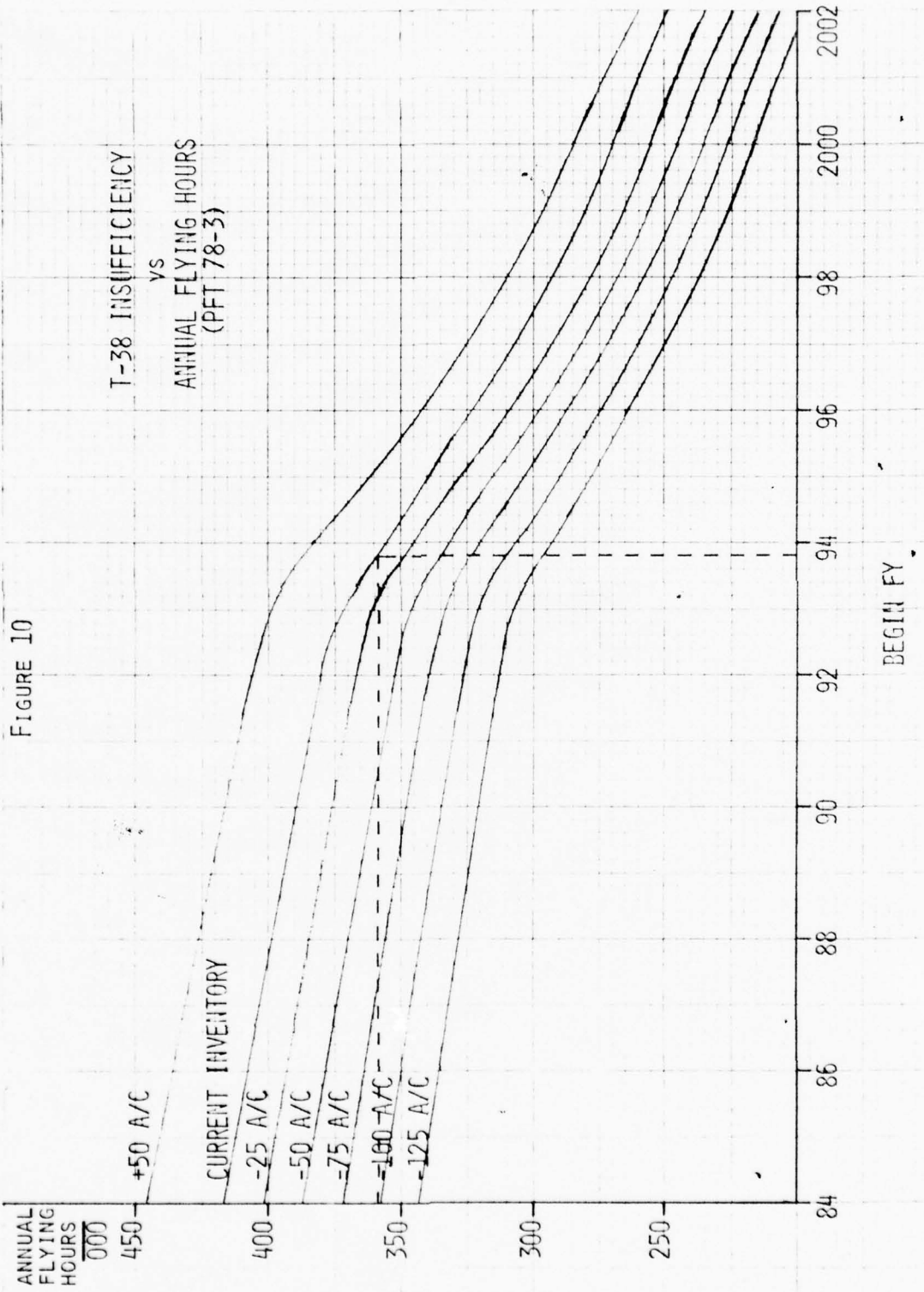

V. FUTURE FORCE, AIRCRAFT, MISSIONS,  
AND PILOT SKILLS

In order to develop future UPT requirements, it first became necessary to examine projected future operational requirements. After determining the types of future systems for which pilot training will be required, pilot skills for these future mission aircraft were examined. In this way, the future operational requirements can be translated into training requirements to be met by the future UPT system alternatives.

Future Force Missions/Aircraft

Based on results of the fleet life expectancy for current UPT aircraft, the period for a future UPT (FUPT) system was determined and defined to be from 1986 to beyond 2000 (1986 - 2006). A limited review of projected Air Force missions and key characteristics of aircraft to perform these missions in this time frame was performed. In addition, existing technology, research and development, along with projected technological advances for future aircraft systems were considered.

Future Aircraft Mix. The following aircraft are expected to make up the active Air Force inventory during the time frame for implementation of alternatives of this

study (Ref. 6, AFSC Planning Activity Report).

- F-4, F-15, F-16, F-106, F-111, Advanced Tactical Fighter (ATF), Advanced Manned Interceptor (AMI)
- B-52, FB-111, B-1
- A-7, A-10
- OV-10, FAC-X
- RF-4, SR-71, RF-X
- C-130, C-141, C-5, Advanced Medium - Short Takeoff (AMST)
- KC-135, Advanced Tanker-Cargo Aircraft (ATCA)
- E-4A, Airborne Warning and Control System (AWACS)
- Orbiting Vehicle, Lighter-than-Air

Many of the above systems are currently in the inventory and will be replaced by follow-on aircraft. Others are only at the stage of concept feasibility and may never prove out, let alone enter production.

Space Missions. Space missions are not considered to impact future UPT for two reasons: (1) space missions are considered as requiring highly specialized training, even into the year 2000; and (2) at most, only a handful of UPT graduates would enter such a training program. USAF pilots, with proven flying abilities, will be selected for various NASA space missions such as the space shuttle. In addition, as in previous space programs, some civilian astronauts may acquire basic flying skills in the future UPT program.

However, the rationale for sending the civilian astronauts through UPT was to teach basic flying skills, thus, in effect, confirming the fact that basic flying skills are required, even for sophisticated space missions.

Technology. Technological advances in aircraft design, performance, and equipment will continue. These advances may lead to increased automation in flying, thus making flying "easier," e.g., automatic landing systems, automatic navigation systems, terrain following, etc. However, automation will not replace the need for acquiring basic flying skills in the event of equipment malfunction or equipment destruction in a combat environment. Furthermore, such equipment is likely to be highly weapon system specific and of insufficient commonality to warrant inclusion in a UPT system.

#### Future Pilot Tasks/Skills

A review was made of the pilot skills and task commonality analyses performed for the Mission Analysis. An extensive pilot skills analysis was performed and coordinated with the MAJCOMS by the Mission Analysis Study Group, which included representatives from other commands.

Another task analysis recently conducted for the Low Cost Aircraft Definition Study (Ref. 7 & 8) reaffirmed the previous Mission Analysis work. This task analysis examined representative mission profiles for the F-4, F-111, B-52, C-5/141 aircraft.

These pilot tasks and skills for current and future systems have again been reviewed as a part of this study. Since the same or very similar aircraft are projected for the future Air Force mission as were used in the prior analyses, no further task analyses were performed during this study.

## VI. TRAINING REQUIREMENTS

The FUPT Mission Analysis identified a set of 30 training requirements which could be taught in the UPT environment. These requirements were selected based on a comprehensive task analysis of functions performed by USAF pilots. These training requirements were recently revalidated by the using MAJCOMS during the ATC/DO Dual Track Study.

It is recognized that some MAJCOMS may feel that some of the listed training requirements are inappropriate for UPT. For example, Tactical Air Command (TAC) considered three of the 30 requirements (tactical formation, basic fighter maneuvers, air-to-ground fundamentals) as the responsibility of the operating commands.

A definite "parochialism" exists on both sides of the training fence, within ATC and within the operating commands. Subsequently, this study first compares training systems which include only 26 of the 30 training requirements. A further comparison is made with a 30 requirement system.

Some changes in definitions and some reorganization of these training requirements have occurred through the continual study processes above; however, they remain substantially unchanged in character. Of the original 30

training requirements, two changes have been identified: (1) combine Spin Recognition and Recovery and Stall Recognition and Recovery into one requirement--Departure Recognition and Recovery; and (2) add Airborne Rendezvous as another requirement.

The T-37 was designed with excellent spin characteristics in order to satisfy the need for spin training required for the aircraft inventory of the time. Current and future aircraft are being designed highly spin resistant or capable of a "hands off" recovery. Subsequently, it appears unnecessary to retain this system specific feature. However, stall recognition and recovery procedures remain as a valid training requirement. Numerous aircraft have missions which require operation at the extremes of the flight envelope. Departure from normal flight may take several forms, including spins, spirals, stalls, etc. These characteristics are recognized and are addressed as a training requirement--Departure Recognition and Recovery.

The added training requirement, Airborne Rendezvous, focuses on the increased and/or continued use of in-flight refueling, cell formation, ground target identification and attack, search-and-rescue, etc. Although not previously identified as a training requirement, it is considered of sufficient task commonality to be included in this study.

Several additional candidate training requirements were considered and rejected for various reasons, usually because they were highly oriented toward a specific weapon or mission. One candidate requirement which has repeatedly surfaced is In-Flight Refueling. It is acknowledged that nearly all future weapons systems will incorporate an in-flight refueling capability. It is therefore worthy of further examination at this point.

To quote directly from the Mission Analysis:

This candidate was deleted. The high commonality with formation training adequately prepares the graduate for this advanced skill. There is little possibility that tanker support will be available for Future Undergraduate Pilot Training. The operational problems of implementing this training in Future UPT, considering the requirement for a dummy tanker and the increased air traffic control load for rendezvous, offset the advantages of introducing this training in Undergraduate Pilot Training.

To further expand on the In-Flight Refueling question, the refueling segment of a task analysis for an F-4E Air-to-Ground mission is presented on the following page as Table 7.

Table 7

SAMPLE TASK ANALYSIS

Segment: Perform Refueling Operations

Function: Execute rendezvous maneuver

- Monitor radar display to detect tanker
- Establish communication with tanker
- Monitor comm/nav system to detect tanker
- Monitor flight instruments and displays
- Visually scan appropriate airspace to detect tanker
- Adjust propulsion subsystem as required for joinup and formation on tanker
- Operate flight controls as required for joinup and formation on tanker
- Use speed brakes if required during joinup on tanker

Function: Configure A/C for refueling

- Set air-to-air refuel subsystem controls for refueling
- Trim A/C prior to refueling
- Deactivate Automatic Flight Control System prior to refueling
- Check radar and armament power switches set as required

Function: Execute hookup and fuel transfer procedures

- Monitor boomers clearance and position directions and director lights
- Adjust propulsion subsystem as required for contact and refueling
- Receive and acknowledge tanker and receiver contact signal
- Check fuel quantity and distribution during refueling
- Trim aircraft as required during refueling

Function: Execute disconnect and breakaway procedures

- Communicate disconnect signal for simultaneous disconnect
- Maintain stabilized position until disconnect confirmed
- Cross-check director lights and visual position until disconnect confirmed
- Receive boom-free report
- Reset air-to-air refueling subsystems

Note that several tasks are the result of subsystems operation (switchology) and communications procedures. Aircraft control operations consist primarily of rendezvous and station-keeping (formation) operations. The actual skills which are peculiar to in-flight refueling are actually quite limited in number; hookup, compensation for changing center of gravity, and disconnect. These operations are quite system specific in themselves, depending on receptacle location and trim/control pressure rates of change during the fuel transfer. Therefore, In-flight Refueling as a training requirement for FUPT is deleted from this study.

Table 8, Pilot Training Requirements Summary, summarizes the training requirements identified as appropriate for FUPT during this study; those currently taught in UPT; those identified by the Mission Analysis; and those training requirements recently validated during the Dual Track Study. Expanded definitions of each training requirement are contained in Appendix C.

Table 8

PILOT TRAINING REQUIREMENTS SUMMARY

<u>Training Requirement</u>	<u>Currently Taught in UPT</u>	<u>Identified by Mission Analysis</u>	<u>MAJCOM Validated for FUPT During Dual Track Study</u>
1. Ground Operations	Yes	Yes	Yes
2. Pre-Takeoff Taxi	Yes	Yes	Yes
3. Takeoff	Yes	Yes	Yes
4. Formation Takeoff	Yes	Yes	Yes
5. Climb/Level Off	Yes	Yes	Yes
6. Descent/Approach	Yes	Yes	Yes
7. Landing	Yes	Yes	Yes
8. Post-Landing Taxi	Yes	Yes	Yes
9. Basic Control	Yes	Yes	Yes
10. Precision Control	Yes	Yes	Yes
*11. Departure Recognition & Recovery Maneuvers	Yes	Yes	Yes
12. Aerobatics	Yes	Yes	Yes
13. Unusual Attitudes	Yes	Yes	Yes
14. Pilotage/Dead Reckoning Navigation	Yes	Yes	Yes

Table 8 (Cont'd)

<u>Training Requirement</u>	<u>Currently Taught in UPT</u>	<u>Identified by Mission Analysis</u>	<u>MAJCOM Validated for FUPT During Dual Track Study</u>
15. High/Low Altitude Navigation (Manual)	Yes	Yes	Yes
16. Close Formation	Yes	Yes	Yes
17. Trail Formation	Yes	Yes	Yes
18. Communications	Yes	Yes	Yes
19. Emergency Procedures	Yes	Yes	Yes
20. Tactical Formation	No	Yes	No
21. Formation Landing	Yes	Yes	Yes
22. Low Level Visual Navigation	No	Yes	Yes
23. Decision Making	Yes	Yes	Yes
24. Basic Fighter Maneuvers	No	Yes	No
25. Air to Ground Fundamentals	No	Yes	No
**26. Air Drop Fundamentals	No	Yes	Yes

Table 8 (Cont'd)

<u>Training Requirement</u>	<u>Currently Taught in UPT</u>	<u>Identified by Mission Analysis</u>	<u>MAJCOM Validated for FUPT During Dual Track Study</u>
27. Radar Navigation	No	Yes	Yes
28. Crew Coordination	No	Yes	Yes
29. Collision Avoidance	Yes	Yes	Yes
30. Airborne Rendezvous	No	(Identified during course of this study)	

\* Combines two previously identified training requirements, Stall Recognition and Recovery and Spin Recognition and Recovery

\*\* Valid only if taught in conjunction with low-level navigation

NOTE: See Appendix C for expanded definitions of training requirements

## VII. TRAINING ALTERNATIVES

The desired goal of any pilot training system is to place a fully qualified, mission-ready, pilot/crew into operational aircraft. This training is by no means accomplished entirely within UPT; numerous CCTS and RTU schools attest to this fact. Each operational aircraft and its mission requires a certain level of proficiency in a large number of pilot skills and tasks. The instruction and acquisition of these skills in the most cost-effective manner is an obvious objective of a pilot training system.

The training requirements previously described form the basis for devising alternative training systems. It should be noted that nearly all of the training requirements identified can be taught to a certain degree in practically any combination of aircraft, with the amount of flying time devoted to each training requirement serving as a major determinant of the level of proficiency attained. For example, increased proficiency in low-level navigation can be obtained within the current UPT program by devoting additional flying sorties to this area. The particular aircraft used to accomplish this training may be somewhat secondary. However, the ability to perform the low

level navigation mission satisfactorily in operational aircraft depends not only on the acquisition of the basic procedural skills, but the similarity in airspeeds and altitudes used in the training environment versus the operational environment.

Therefore, it must be recognized that merely teaching basic flying skills is not the sole responsibility of ATC/UPT, but rather to train military aviators capable of upgrading into operational USAF aircraft with minimal additional training. Ideally, post-UPT follow-on training should be limited to checkout in mission-unique aircraft, equipment, and procedures.

Under these assumptions numerous training system alternatives have been identified for FUPT--many of which were explored in the Mission Analysis. Figure 11, Training Alternatives, depicts some systems which were examined in this study.

The present, non-IFS, UPT syllabus (90 T-37 hours, 120 T-38 hours) is not depicted; however, the projected IFS syllabus is used as a baseline. This syllabus provides 71.8 flying hours in the T-37 phase and 98.2 in the T-38 phase for a total of 170 hours. The plus or minus (+) indicates the potential to increase or decrease phase flying hours or total hours depending on the training

FIGURE 11

PRELIMINARY TRAINING ALTERNATIVES

BASELINE

T-37  
71.8 Hrs

---

T-38  
98.2 Hrs

MODIFIED

T-37  
71.8 + ?

---

T-38  
98.2 + ?

XT-1  
71.8 + ?

---

T-38  
98.2 + ?

XT-1  
71.8 + ?

---

XT-1  
98.2 + ?

---

XT-1  
?

XT-2  
170+ ?

XT-2A  
71.8 + ?

---

XT-2B  
98.2 + ?

XT-2A  
71.8 + ?

---

XT-2B  
98.2 + ?

---

XT-2A  
?

XT-3 (or XT-1)  
71.8 + ?

---

XT-3  
98.2 + ?

---

XT-3  
?

philosophy selected and on the equipment/performance characteristics of new trainer aircraft. For example, use of a flight director system in a primary trainer could reduce training time in a similarly equipped basic trainer.

Since the T-37 fleet is not projected to last beyond 1988, the first alternative would be to modify the T-37 aircraft in some fashion to extend the fleet life and/or change equipment so as to reduce O&S costs. For example, an unsolicited engineering change proposal, ECP 391 (Ref. 9), by the Cessna Corporation, builders of the T-37, would extend the design life to 18,000 hours and reduce fuel consumption 47% by reengining the T-37 with turbofan engines.

A second alternative, shown in Figure 11, is to replace the 20 year old T-37 with a new aircraft (designated XT-1 for purposes of this study). In very general terms, this replacement aircraft would have performance characteristics in the class of the current T-37, with turbofan engines, modern avionics, and significantly less gross weight. As noted in Figure 11, the potential exists to increase the flying time in the XT-1, thus reducing T-38 flying hours and extending the T-38 fleet life.

The XT-1 could also be designed to fulfill the Tanker-Transport-Bomber (TTB) leg of a dual track FUPT system, as well as filling the primary trainer role of the Fighter-Attack-Interceptor-Reconnaissance (FAIR) leg of such a system.

Another alternative is selection of a single aircraft which would replace both the T-37 and the T-38 aircraft. This all-through aircraft is designated as the XT-2 for purposes of this study. Conceptually, this aircraft would be a high subsonic, twin turbofan, tandem seated aircraft. This alternative offers several possibilities for life cycle cost savings, especially in the logistics area (support only one aircraft), as well as a potential overall syllabus reduction (from 170 hours) as training time to check out in a second aircraft would no longer be required. Conversely, additional training could be accomplished within the 170 hour framework. For comparison, a syllabus maintaining graduate quality with reduced flying hours is used.

An offshoot of the all-through aircraft is the possibility of building two aircraft with a high degree of subsystem commonality (engines, avionics, gear, flight controls, etc.) but with different seating arrangements (side-by-side in one, tandem in the other). This concept uses the designation XT-2A and XT-2B, with the A model side-by-side, and the B model with tandem seating. The actual feasibility of this concept has not yet been determined, but it presents interesting possibilities. Corollary to this concept is using these two aircraft in a dual-track system.

An additional alternative (XT-3) is an aircraft specifically designed for use as both a primary trainer and a basic TTB trainer. This aircraft, in general terms, would have three-place seating, twin turbofan, and increased range and speed over the XT-1 alternative.

The last alternative proposes the purchase of two aircraft; the XT-1 for use in the primary phase of a dual track system, the XT-3 for use in the TTB leg, and continued use of the T-38 in the FAIR leg.

#### Candidate FUPT Systems

Several of the alternatives presented were discarded after closer examination. Three basic candidate systems remain as depicted in Figure 12, Candidate FUPT Systems. The following paragraphs summarize the reasons for deleting various alternative systems.

Modified T-37. This alternative was eliminated due to the high cost of the Cessna proposed reengine modification as compared to the additional increase in fleet life. Evaluation of the Cessna proposal indicated that it would merely delay the requirement to acquire new aircraft for a few years, while extending fleet life almost long enough to pay for the modification (Ref. 10). This was confirmed by HQ USAF/ACMC (Ref. 11).

CANDIDATE FUPT SYSTEMS

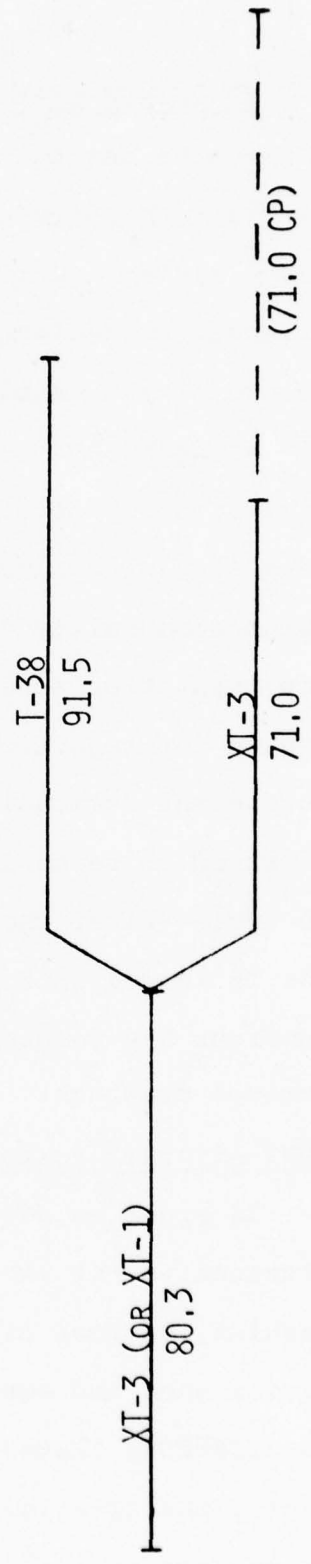

FIGURE 12

XT-1/T-38 Specialized UPT. This alternative was eliminated due to the limited potential of a two-place aircraft to satisfactorily train the TTB leg of a dual track system. During the Dual Track Study this point was strongly emphasized by the operating commands in reference to use of the existing T-37 as a TTB basic trainer.

XT-2A/XT-2B. Although an interesting concept, the time required to adequately determine the feasibility of this concept excluded it from further consideration. This "high-commonality" approach also seems to be more of an implementation scheme than a true alternative. A third reason for rejection was that the "B" version, if tied to sufficient commonality with the "A" version, would be deprived of technological advances accruing during the phase-in cycle (first the "A" model as a T-37 replacement, then the "B" model as a T-38 replacement). Experience with the numerous F-4 versions indicates that this may not be a serious drawback.

#### FUPT Aircraft Performance Requirements

In order to determine the most cost effective training alternative, it is necessary to design, in a preliminary fashion, various aircraft which meet a set of desired performance and equipment parameters. The performance requirements listed in Table 9 for the XT-1 (T-37 replacement), the XT-2 (all-through aircraft), and the XT-3 (Dual Track) are an initial set of requirements only.

Table 9

PERFORMANCE REQUIREMENTS

<u>Design Parameter</u>	<u>XT-1</u>	<u>XT-2</u>	<u>XT-3</u>
1. Takeoff ground run, feet	2,000	3,000	2,500
2. Takeoff time, seconds	10-15	Same	Same
3. Landing roll, feet	≤ 4,000	Same	Same
4. Approach speed, knots	90-110	110-135	90-110
5. Landing speed, knots	≤ 80	≤ 100	80
6. Rate of climb (nominal mission conditions), fpm	> 2,000 (15,000' alt)	> 8,000 (15,000' alt)	> 4,000 (15,000' alt)
7. Single engine rate of climb (not day, takeoff configuration), fpm	> 400 (7,000' alt)	> 1,000 (7,000' alt)	> 400 (7,000' alt)
8. Endurance in normal cruise (standard day, no wind), nautical miles	> 750 (25,000' alt)	> 1,100 (30,000' alt)	> 1,100 (30,000' alt)
9. Endurance in normal cruise, hours	2.5 (25,000' alt)	2.5 (30,000' alt)	3.0 (30,000' alt)
10. Cruise ceiling, feet	≥ 25,000	≥ 35,000	≥ 35,000
11. Sustained load factor, g's (Altitude)	> 2.5 (25,000' alt)	> 2.5 (35,000' alt)	> 2.5 (25,000' alt)

Table 9 (cont'd)

PERFORMANCE REQUIREMENTS

<u>Design Parameter</u>	<u>XT-1</u>	<u>XT-2</u>	<u>XT-3</u>
12. Instantaneous load factor, g's	> 4.0 (25,000' alt)	> 5.0 (35,000' alt)	> 4.0 (25,000' alt)
13. Life expectancy, flight hours	15,000	Same	Same
14. Handling qualities	Highly spin resistant and excellent handling	Same	Same
15. Maximum speed, knots/mach	Fallout, but $\geq 300$ knots	Fallout, but high subsonic (> .85 mach)	Fallout, $\geq .75$ mach

### FUPT Aircraft Equipment Requirements

Table 10 provides a list of desired equipment for the three aircraft. Several items are noted with an asterisk (\*) which denotes a possible optional capability.

Cockpit Configuration. Although numerous cockpit seating configurations have been proposed, they generally fall into three categories: side-by-side, tandem, and three-place. From strictly an instructional viewpoint, the side-by-side configuration appears to be advantageous, whereas the tandem arrangement is better suited to higher performance aircraft and FAIR follow-on aircraft. A three-place trainer is better suited for TTB training and for use in a "dynamic observer" concept. An evaluation of the advantages and disadvantages of side-by-side versus tandem seating is presented in Appendix F.

### FUPT Aircraft Maintenance Considerations

Any future trainer aircraft must be designed with maintainability uppermost in mind for several reasons: (1) the high number of flying hours expended annually by ATC, (2) low experience levels of student pilots, and (3) relatively long service life of trainer aircraft. Design parameters for logistics support are listed below. Technological advances may require modification to these parameters in future design iterations.

Table 10

EQUIPMENT REQUIREMENTS

<u>Design Parameter</u>	<u>XT-1</u>	<u>XT-2</u>	<u>XT-3</u>
1. Avionics, Communications	UHF, Hot Mike Intercom	UHF, Hot Mike Intercom	UHF, VHF,* Hot Mike Intercom
2. Avionics, Navigation	VOR-DME, GPS,* ILS or MLS,* IFF/SIF, Marker Beacon	TACAN, VOR, GPS,* ILS or MLS*, IFF/SIF, Marker Beacon	Same as XT-2
3. Avionics, Special	Collision Avoidance*, Crash Position Indicator	Same	Same
4. Instruments, Engine	Conventional State-of-the-art, round dial	Conventional State-of-the-art, Vertical tape* (pilot's cockpit) and round dial (co-pilot's cockpit)	Conventional State-of-the-art, Vertical tape*
5. Instruments, Flight	Conventional State-of-the-art, Round dial, angle-of-attack, Flight Director	Conventional State-of-the-art, vertical tape* (pilot's cockpit) and round dial (co-pilot's cockpit) Heading Reference system, Flight Director, angle-of-attack, HUD*	Conventional plus minimum for flight at third seat

Table 10 (cont'd)

EQUIPMENT REQUIREMENTS

<u>Design Parameter</u>	<u>XT-1</u>	<u>XT-2</u>	<u>XT-3</u>
6. Status Monitoring	Conventional light monitoring, master caution panel	Same	Same
7. Air Conditioning	Provided	Provided	Provided
8. Bird-proof Windshield & Canopy	Provided	Provided	Provided
9. Windshield, engine anti-ice	Windshield, inlet guide vanes and pitot-static anti-icing	Same	Same
10. Windshield wiper, defoggers	Defoggers	Same	Same
11. Oxygen & Pressurization	Oxygen, Pressurization*	Both	Both
12. Escape System	Zero-Zero	Same	Same
13. Standard Emergency System	Provided	Provided	Provided
14. Seating Configuration	° ↑	° ↑	° ° ↑

Airframe

(1) At least 95% of systems components (normal removal and replacement) should be accessible from exterior doors.

(a) Equipment bays are preferable to minimize removable or hinged exterior panels.

(b) Access panels hinged at front to prevent inflight panel loss.

(c) Ground level access to all system components.

(d) System components should be centrally located in one equipment bay whenever possible.

(2) Flight control system should only be touched while performing flight control system maintenance.

(a) Maintenance of non-flight control components should not require handling, removal, disconnection, etc., of flight control components.

(b) Cabled flight controls where possible.

(3) Radios should work off battery when engines not running.

(4) Redundancy in critical systems

(a) flight controls

(b) electrical sources (generators, inverters, etc.)

(c) communications

(d) attitude instruments

(5) Engine changes should not require aft section removal, aircraft jacking, etc.

(6) Basic structural members, including exterior covering, should be designed for organizational/intermediate maintenance with stress on ease of maintenance.

(7) Sophisticated manufacturing processes should be avoided.

(8) Aircraft should have a built-in storage/cargo compartment capable of carrying most aircraft components (excluding big, bulky items) and/or clothes.

(a) enhances off station support

(b) safer than stuffing clothes under seats, in communication equipment bays, etc.

(c) eliminates need for an external pod

(9) Windscreen/canopy design should provide good optics while providing reasonable resistance to bird strikes.

(10) Tire changes should be simple, no door removal, etc.

#### Power Plant

(1) Engine should be selected or designed to maximize fuel conservation.

(2) Maximize engine subsystems to reduce maintenance costs, e.g., no afterburner.

(3) Engine selection should be based on maintainability as well as performance.

(4) Basic engine components (igniter plugs, exciter, transmitters, gear box driven equipment, etc.) should be accessible without engine removal.

(5) Engine(s) should be capable of starting without an external power/air source.

#### Mission Profiles

For each training alternative there are several typical missions which would be flown to accomplish the desired training objectives. These missions vary in altitude, speed, range, maneuvering, etc. Of each set of missions for a given training alternative, a subset of missions will act to bound the aircraft design. For example, a two-hour navigation mission could be accomplished with aircraft of several fuel capacities. However, designing an aircraft capable of a five-hour navigation mission would be highly questionable if no mission requires such capacity. Therefore, to accomplish the navigation mission, the two-hour fuel endurance (plus appropriate reserves) serves as a design parameter for "sizing" the aircraft from the navigation viewpoint. A low-level navigation mission of, say, 1 1/2 hours, since it would be flown at lower altitudes and different airspeeds, may require an increased fuel capacity over the two-hour navigation mission. If this is

the case, then the low-level mission becomes the "sizing" mission. Similarly, a 1.3 hour aerobatic mission may ultimately become the "sizing" mission from a fuel capacity viewpoint. Airspeeds, altitudes, etc., similarly influence or bound the aircraft design.

Figure 13 depicts a sample mission profile for an advanced contact mission to be flown in a primary trainer aircraft (XT-1). The horizontal axis depicts time, in minutes, from engine start to engine shutdown. The left-hand vertical axis depicts altitude, in feet. Running horizontally across the top of the chart is a series of numbers which correspond to a more detailed description of each maneuver. These maneuvers are described in Tables 11 and 12. A complete set of mission profiles is contained in Appendix D.

The mission profiles depicted, as with performance and equipment requirements, are for conceptual design use in this study and represent a "best guess" only. The profiles developed herein are certainly subject to change, further examination and definition may be required prior to future aircraft design efforts.

FIGURE 13

T-37 REPLACEMENT AIRCRAFT - SAMPLE ADVANCED CONTACT MISSION

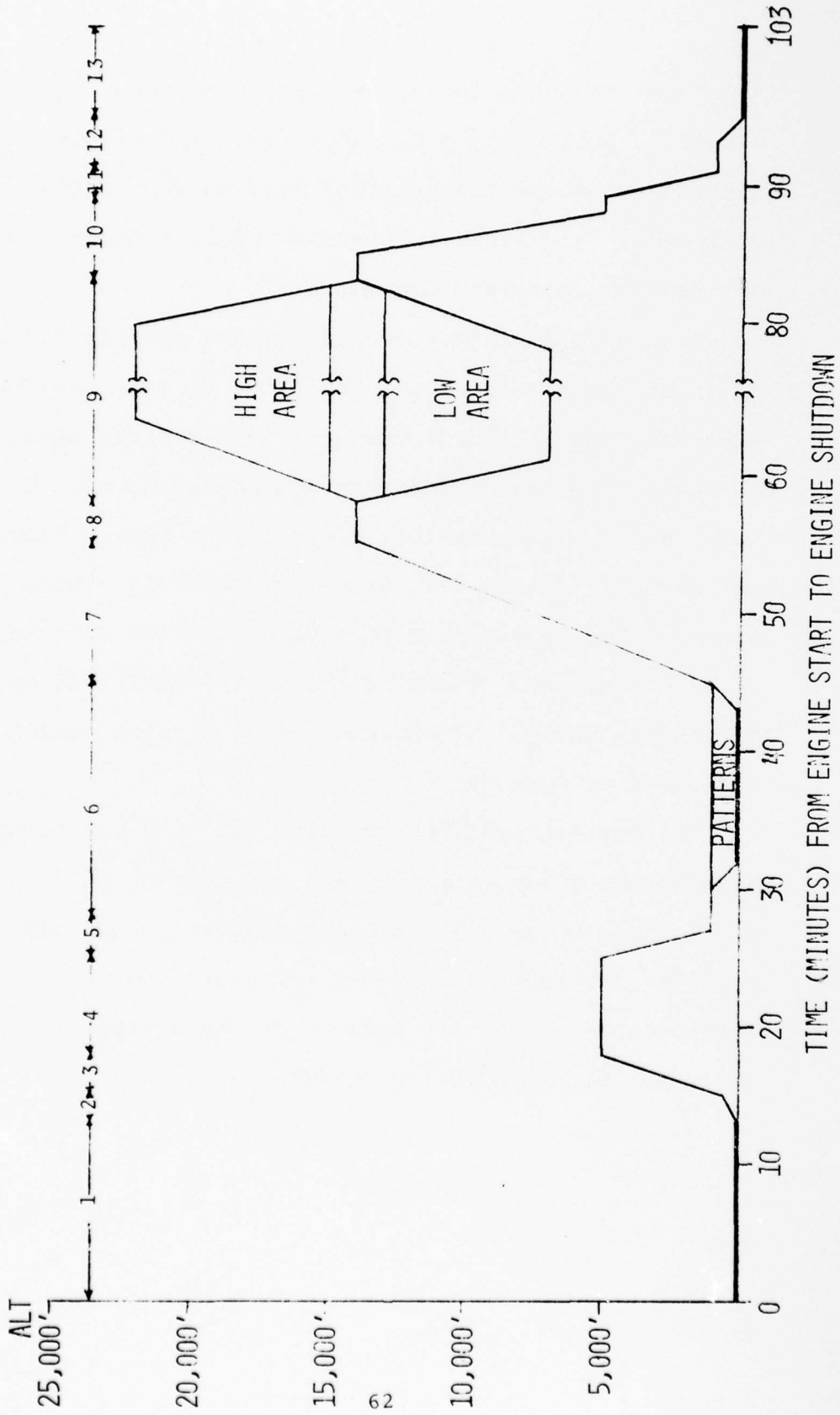

Table 11

T-37 REPLACEMENT AIRCRAFT - SAMPLE ADVANCED CONTACT MISSION

General Description: This is the second of two contact mission extremes encountered in the primary phase of UPT. Mission profile may vary from that presented below, but generally consists of the following: takeoff from home field, climb to an intermediate altitude, proceed to auxiliary airfield for pattern work, climb to assigned area for area work, descend and return to home field for landing.

	<u>Time and/or Distance</u>	<u>Altitude</u>	<u>Power Settings</u>
1. Start/taxi	12-15 min	0' AGL	Idle to taxi power
2. Takeoff	2 min	500' AGL	Mil
3. Climb/level-off	3 min	5,000' MSL	Mil to normal cruise
4. Cruise to auxiliary field	5-10 min	5,000' MSL	Normal cruise
5. Descent/pattern entry	3 min	1,000' AGL	Idle to power to hold 200 KIAS
6. Traffic pattern work	15-20 min	1,000' to 0' AGL	Mil to idle
a. Straight-in approach			
b. Closed traffic pattern			
c. Normal touch and go landing			
d. Single engine touch and go landing			
e. No-flap touch and go landing			
f. Go-around (optional)			
g. Low approach (optional)			
7. Climb/level-off	10 min	13-15,000' MSL	Mil to normal cruise
8. Cruise to area (optional)	2-5 min	13-15,000' MSL	Normal cruise
9. Area work	15-min/max distance from home field = 60 mi	7-13,000' MSL or 15-22,000' MSL	Idle to mil
a. Traffic pattern stalls			
b. Power on stalls			
c. Slow flight			
d. Inverted recovery			

Table 11 (cont'd)

	<u>Time and/or Distance</u>	<u>Altitude</u>	<u>Power Settings</u>
e. Vertical recovery			
f. High speed dive recovery			
g. Aerobatics			
h. Max performance maneuvers			
10. Area exit/descent	6 min	5,000' MSL	Idle to power on
11. Pattern entry	2 min	1,000' AGL	Power to hold 200 KIAS
12. Full stop landing	4 min	1,000'-0' AGL	Power to hold 200 KIAS to idle
a. No-flap			
13. Taxi/engine shutdown	10 min	0' AGL	Idle to taxi power
14. Reserve	20 min	10,000' MSL	Max endurance

Table 12

Maneuver Description - Advanced Contact Mission

1. Start/taxi - previously explained/self-explanatory.
2. Takeoff - previously explained/self-explanatory.
3. Climb/level-off - generally consists of climbing the aircraft at its best climb speed and leveling off at a locally specified altitude.
4. Cruise to auxiliary airfield - normal cruise along a locally designated ground path to an auxiliary airfield.
5. Descent/pattern entry - previously explained/self-explanatory.
6. Traffic pattern work - due to traffic pattern congestion at the home field, all traffic patterns except the full stop pattern are completed at the auxiliary field. Time spent at the auxiliary airfield is inversely proportional to the skill level of the student. There is no set pattern for ordering traffic patterns, but generally, the sequence is as follows (for an advanced student): straight-in approach, normal overhead pattern, single-engine overhead pattern, no-flap overhead pattern. One of the overhead patterns in the sequence is normally reserved as the full stop landing at the home field. Go-arounds and low approaches are flown when necessary. To save time, most overhead patterns are flown using a closed traffic pattern entry.
7. Climb/level-off - consists of departing the auxiliary field and climbing to the locally designated point where an assigned area can be entered. Climb is at best climb speed.
8. Cruise to area - optional, since some local area procedures allow climb direct to an area. Generally, however, some level cruising, at normal cruise, is encountered prior to reaching the assigned area.
9. Area work - begins with a change of power to enter the assigned area, and ends with a change of power to exit the assigned area. Includes the performance of required maneuvers, and time to analyze, set up and critique those maneuvers. An absolute minimum of 100 square miles of airspace are required for each area. Areas are usually stratified into high (15-22,000') and low (7-13,000') blocks for maximum utilization of airspace.
10. Area exit/descent - consists of a descent to a locally designated altitude, and compliance with a locally designated return route. A climb may be necessary from a low area, but normal area exit entails an idle to reduced power letdown.
11. Pattern entry - previously explained/self-explanatory.
12. Full stop landing - consists normally of the overhead pattern not accomplished at the auxiliary airfield.
13. Taxi/engine shutdown - previously explained/self-explanatory.
14. Reserve - previously explained/self-explanatory.

### Syllabus Development

The training syllabi developed for purposes of this study are quite general in nature. No attempt was made during this study to develop a detailed syllabus. The syllabi depicted in Table 13 are only for UPT under each of the selected training alternatives. Whenever non-UPT programs needed to be considered, an equivalent production or flying hour figure was calculated in the same proportions as under the projected UPT-IFS syllabus (see Table 5).

A prime function of syllabus development, for purposes of this study, is to identify the total flying hour requirements so as to cost out the various alternatives. Actual syllabus development is a fairly lengthy process; the exact composition of dual, solo, team sorties, as well as number of sorties devoted to each training category, varies as experience is gained in a particular training system.

At this point it is important to reiterate that these syllabi do not envision any significant differences in graduate quality. This was purposely done to ensure a common basis for cost comparisons.

A very real consideration, which should be addressed prior to actually committing ATC and USAF to a particular UPT training system, is the total USAF flying training program. We have seen a significant increase in the

Table 13  
FUPT SYLLABUS COMPARISON  
 (Sorties/Hours)

	<u>T-37 Replacement</u>		<u>All-Through</u>		<u>Dual Track</u>	
	<u>XT-1</u>	<u>T-38</u>	<u>XT-2</u>	<u>T-38</u> (FAIR)	<u>XT-3</u> (TTB)	<u>XT-3</u> (TTB)
Aircraft	61/80.3	74/91.5	126/154.1	61/80.3	74/91.5	47/71.0
(Dynamic Observer)*	(4/5.2)	(10/12.4)	(19/24.2)	(4/5.2)	(10/12.4)	
Co-Pilot**						47/71.0
Simulator	27/35.3	28/36.4	58/76.1	27/35.3	28/36.4	28/36.4
Training Days	81	108	189	81	108	108

\* Additional aircraft flying time as Dynamic Observer will not count towards career flying time.

\*\* Co-Pilot time is additional flying time which will count towards career flying time.

training roles of the operating MAJCOMS as evidenced by increased CCTS, TAC lead-in training (LIT), and the ACE program. Some programs, such as ACE, are a result of reduced flying hours USAF-wide, and a resultant increase in the length of time required to "age" a pilot. Other programs, such as lengthened CCTS and LIT, are designed to teach or further enhance somewhat basic, mission-oriented, flying skills and procedures. Admittedly, a certain portion of this training is utilized for transitioning from trainer to operational aircraft.

Two major drawbacks to increased post-UPT training are readily evident: (1) training is performed in more expensive Unit Equipment (UE) aircraft, and (2) operational pilots must be dedicated against a training rather than an operational mission.

#### Concept Designs

Several conceptual design iterations were performed by AFSC/ASD for each class of aircraft--XT-1, XT-2, and XT-3. A representative design from each series was selected for comparison. Neither airframes nor engines represent existing, off-the-shelf equipment, but are of the "paper" category. Sufficient technology exists, however, to produce these aircraft or some derivative thereof. The concepts provided are subject to further study and refinement--in particular the somewhat unconventional XT-3

concept. The designs presented here serve only to provide an estimate of acquisition and operating costs for the alternative UPT systems.

Figures 14 through 16 depict the three candidate aircraft. Figure 17 is a comparative profile view of the three aircraft. Table 14 summarizes performance capabilities of the candidate aircraft. It should be noted that design work is at the conceptual level and only of sufficient detail to allow a comparison of alternative training systems. A more detailed discussion of airframe and engine characteristics is being prepared as ASD report Next Generation Trainer.

#### Concept Cost Data

Aircraft RDT&E and acquisition costs were estimated via the Rand DAPCA III model for estimating development and procurement costs of aircraft (Ref. 12 & 13). Figure 18 plots aircraft acquisition costs as a function of procurement level for each of the candidate aircraft.

O&M Costs. O&M costs constitute a significant, if not predominant, share of aircraft life cycle costs. Unfortunately, cost estimating relationships for such items as Depot Maintenance, Maintenance Material, and Replenishment Spares costs per flying hour were unavailable for this report. Therefore, estimates were based on current trainer aircraft for which such costs were available in AFM 173-10 (Ref. 14).

FIGURE 14

XT-1

GROSS WEIGHT = 4378 LB

WING AREA = 125.8 SQ FT

THRUST/ENGINE = 1035 LB

SPAN = 35.5 FT

LENGTH = 28.6 FT

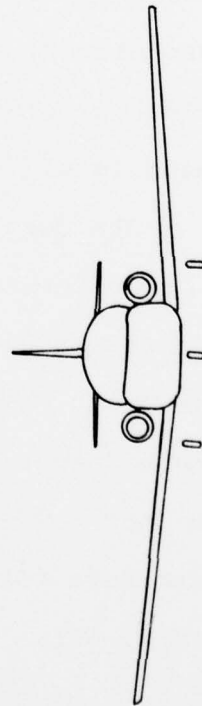
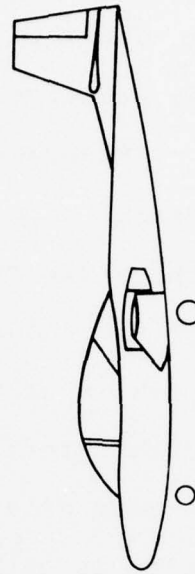
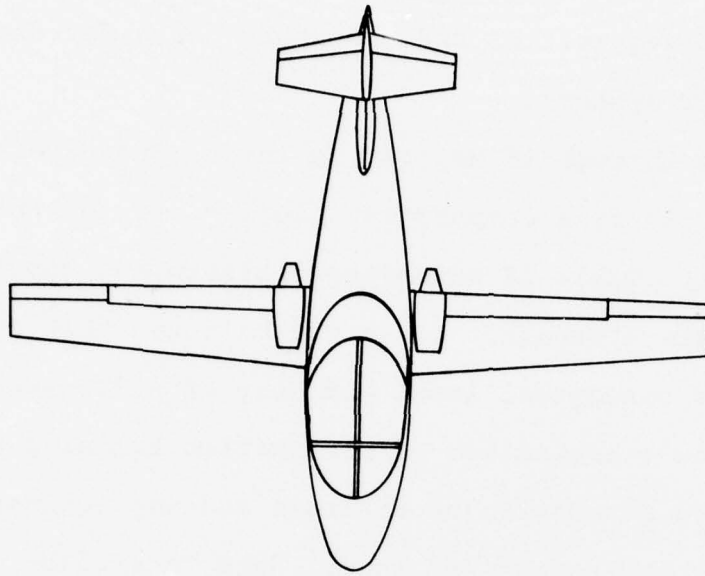

FIGURE 15

XT-2

GROSS WEIGHT = 8380 LB

WING AREA = 178 SQ FT

THRUST/ENGINE = 2472 LB

SPAN = 32.7 FT

LENGTH = 38.6 FT

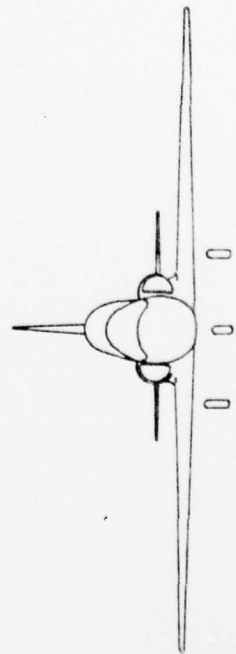
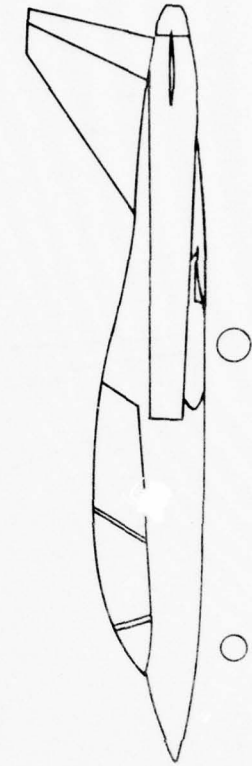
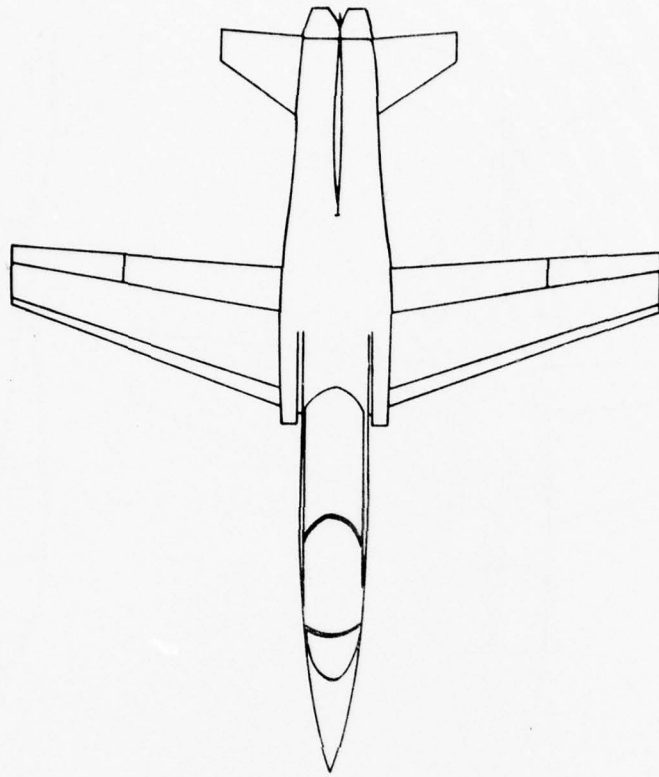

FIGURE 16

XT-3

GROSS WEIGHT = 8135 LB

WING AREA = 234 SQ FT

THRUST/ENGINE = 1883 LB

SPAN = 37.5 FT

LENGTH = 36.1 FT

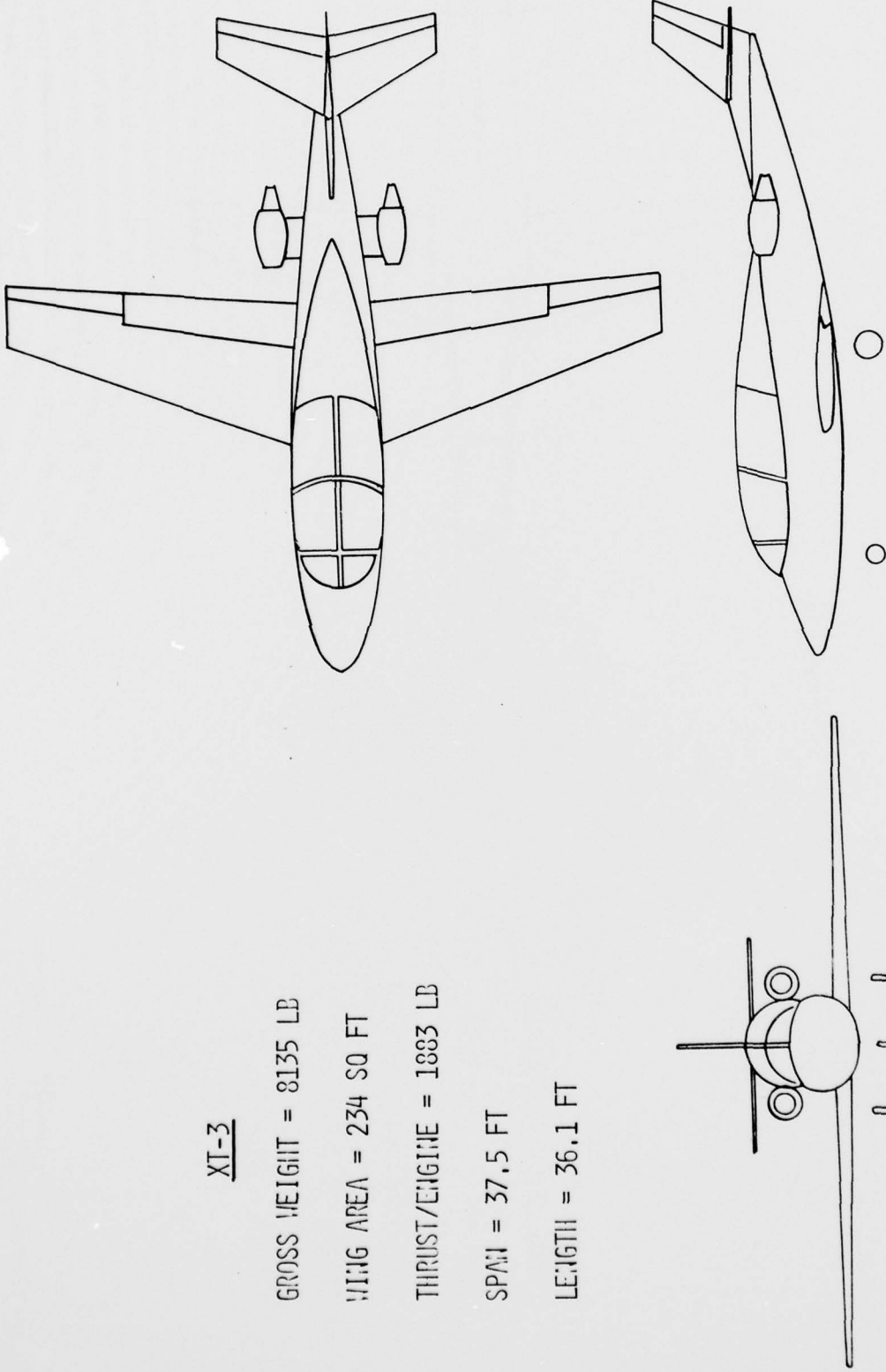

FIGURE 17

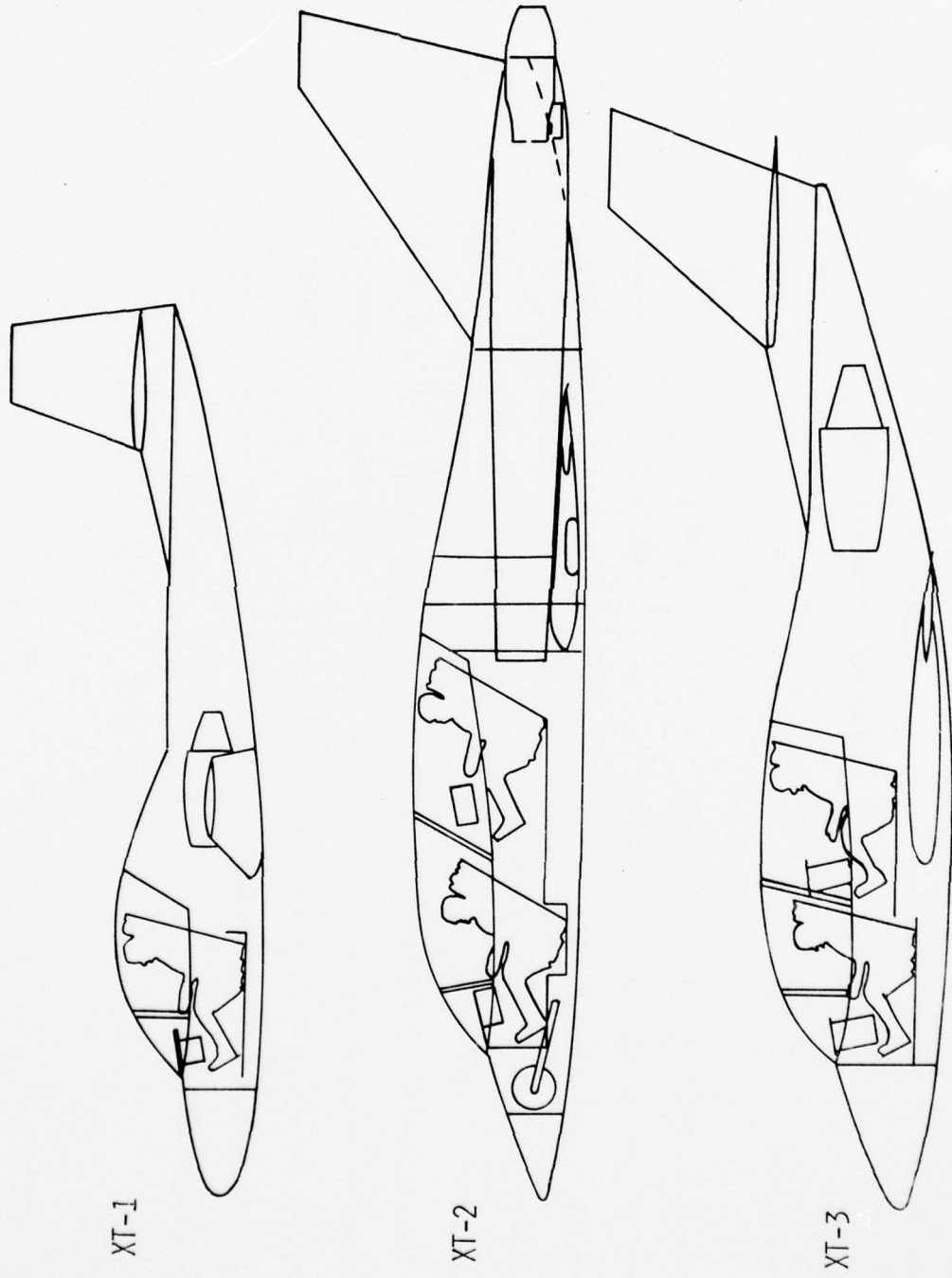
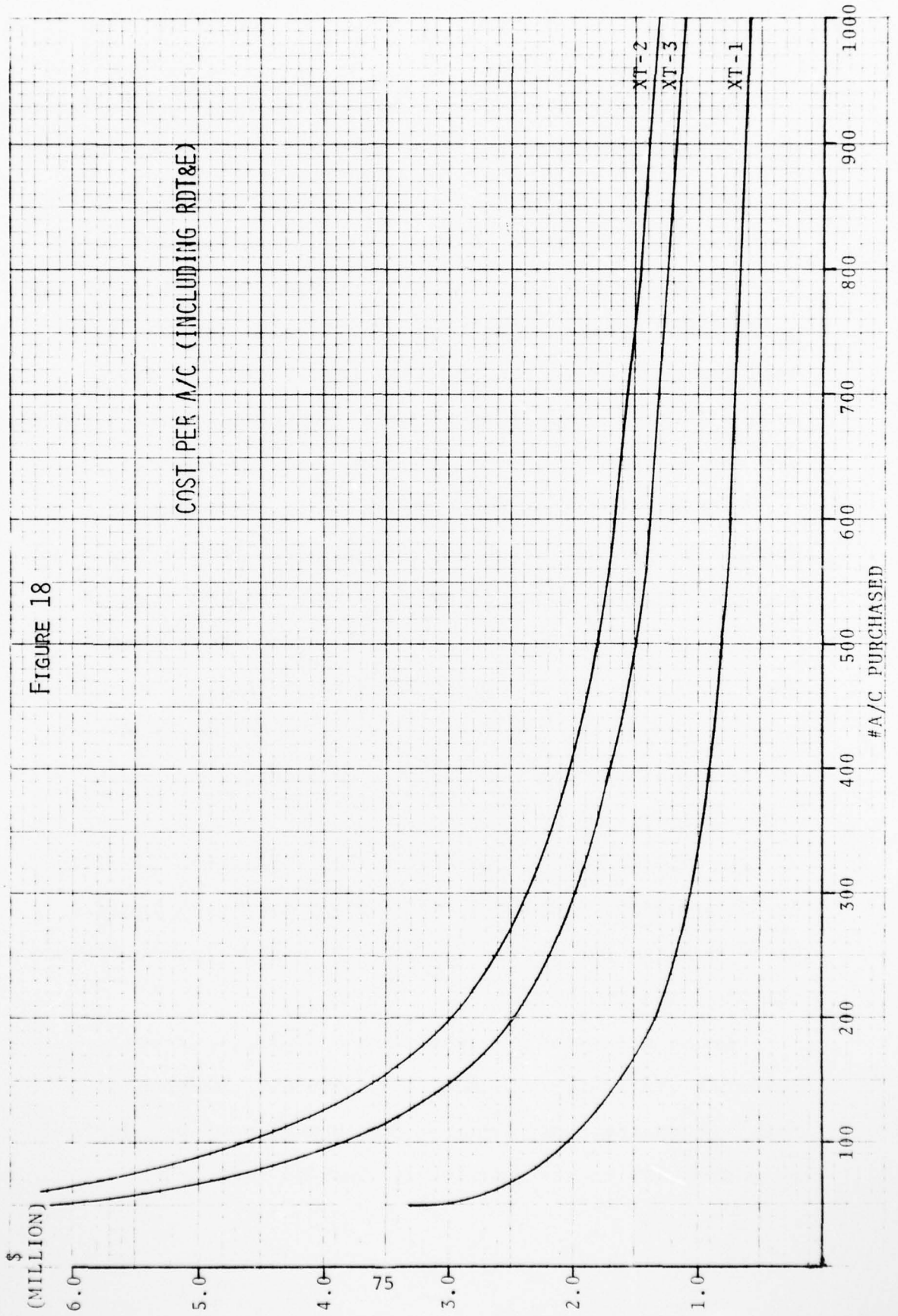

Table 14

AIRCRAFT DESCRIPTION

	<u>XT-1</u>	<u>XT-2</u>	<u>XT-3</u>
SEATING CONFIGURATION	00↑	0↑	0 0↑ 0
TAKE-OFF GROSS WEIGHT	4378	8380	8185
THRUST PER ENGINE	1035	2472	1883
APPROACH SPEED (SEA LEVEL)	90	110	90
MAXIMUM SPEED (MACH)	.65	.91	.807
SUSTAINED G's/ALTITUDE	2.5/25K	2.82/35K	2.91/25K
NORMAL RATE OF CLIMB	2000/26K	8000/15K	4000/15K
SINGLE-ENGINE ROC (7000', HOT DAY)	400	1000	400
FUEL CONSUMPTION (GAL/HR)	49	126	108
MAINTENANCE MH/FH	4.95	6.6	5.82

FIGURE 18



Depot Maintenance, Maintenance Materials, and Replenishment Spares costs for the XT-1 were estimated based on: (1) current T-37 values, (2) estimated values for a T-37 modified with turbofan engines, and (3) values developed for use in the Low Cost Aircraft program for a side-by-side proficiency trainer. A "best guess" value for the XT-1 used the mean of values provided in (2) and (3) above. Both a lower and upper bound were developed by using the minimum and maximum values of (1), (2), and (3) above.

A "best guess" of Depot Maintenance, Maintenance Materials, and Replenishment Spares costs per flying hour for the XT-2 was obtained by using the mean of current AFM 173-10 values for the T-37 and T-38. Lower bounds were derived using the midpoint between the XT-2 means, derived above, and the T-37 values. Upper bounds used the midpoint between the derived XT-2 means and current T-38 values.

Per flying hour costs for the XT-3 were generated in the same manner. However, T-39 costs were used instead of T-38 costs due to the similarity in performance between the XT-3 and the T-39.

Direct maintenance manhours per flying hour were computed via a Northrop set of equations. An upper bound for maintenance manhour per flying hour was derived by adding 20% to the previously derived factors.

AD-A053 374

AIR TRAINING COMMAND RANDOLPH AFB TX DIRECTOR OF OPE--ETC F/6 1/3  
ALTERNATIVES FOR FUTURE UNDERGRADUATE PILOT TRAINING, (U)  
APR 77 S G JOSEPH

UNCLASSIFIED

77-1

NL

2 of 3  
AD  
A053374



Aviation POL costs per flying hour were based on fuel consumption rates provided by ASD and an into-plane fuel cost of 44.1 cents per gallon.

Table 15 summarizes flying hour costs used in this evaluation.

#### Aircraft Production Requirements

The total number of new aircraft required under each option is a function of annual flying hours. Aircraft monthly utilization rates of 60 hours per month are used for each option. (Monthly utilization rates are dependent upon sortie length, turn time, and, predominantly in ATC, available daylight hours, see Ref. 15.) Using an 11 1/2 month training year, and a Not Operationally Available rate of 5%, aircraft requirements are computed by the following formula:

Aircraft Required =

$$\frac{\text{Annual flying hours}}{12 \text{ months}} \times \frac{11 \frac{1}{2}}{12} \div 60 \text{ hrs/mos} \times 1.05$$

In addition, aircraft must be procured to account for accident attrition. In the case of the XT-1 and XT-3 options an aircraft attrition rate of 1/100,000 hours is used; for the XT-2, 1.5/100,000. Over a 20 year period additional aircraft required are computed by:

$$\text{Additional A/C req'd} = \frac{\text{Annual flying hrs}}{100,000} \times \text{Attrition rate} \times 20 \text{ yr}$$

Table 15

Flying Hour Cost Summary

	<u>T-37</u>	<u>T-38</u>	<u>XT-1</u>	<u>XT-2</u>	<u>XT-3</u>
Fuel Consumption (gal/hr)	185	400	49	126	108
Av Pol cost/FH(\$)	81.59	176.40	21.61	55.57	47.63
Depot Maintenance (\$)	24.00	65.00	26.00	44.50	43.00
Lower Bound			24.00	34.25	33.50
Upper Bound			28.00	54.75	52.50
Maintenance Material (\$)	16.00	54.00	14.00	35.00	18.50
Lower Bound			12.00	25.50	17.25
Upper Bound			16.00	44.50	19.75
Replenishment Spares (\$)	12.00	34.00	14.00	23.00	17.50
Lower Bound			12.00	17.50	14.75
Upper Bound			14.00	28.50	20.25
Maintenance mh/fh	6.7	10.2	4.95	6.6	5.82
Upper Bound			5.94	7.92	6.98

By entering Figure 19 at total "annual flying hours," one can readily determine the required procurement level.

#### Phase-in Schedules

Phase-in schedules were developed for each alternative based on production levels and syllabi previously discussed. Table 22 in Appendix H depicts, by month, cumulative aircraft production, available monthly flying hours, and cumulative annual flying hours based on a production rate of 20 aircraft per month, 60 hours per month utilization rate, 11 1/2 month year. For purposes of evaluation, a straight line procurement program is used; however, alternative phase-in programs could possibly be developed which maximize T-37 fleet life.

Tables 23 through 26 in Appendix H demonstrate phase-in/conversion of flying programs by flying hours by year. These tables are used later for computation of system costs. The number of new aircraft required to support the depicted flying hour programs is shown in the right hand column. In parentheses() is the number of additional aircraft required due to accident attrition. Tables 25 and 26 depict T-38 flying hours required in support of both a 26 training requirement system and a 30 requirement system (without and with a tactical phase).

A pictorial representation of aircraft phase-in schedules for each option is provided in Figure 20. Note that a T-38 replacement is required in the mid-90s under Option I, whereas under Options IIIA & B, T-38 fleet life is extended substantially.

FIGURE 19

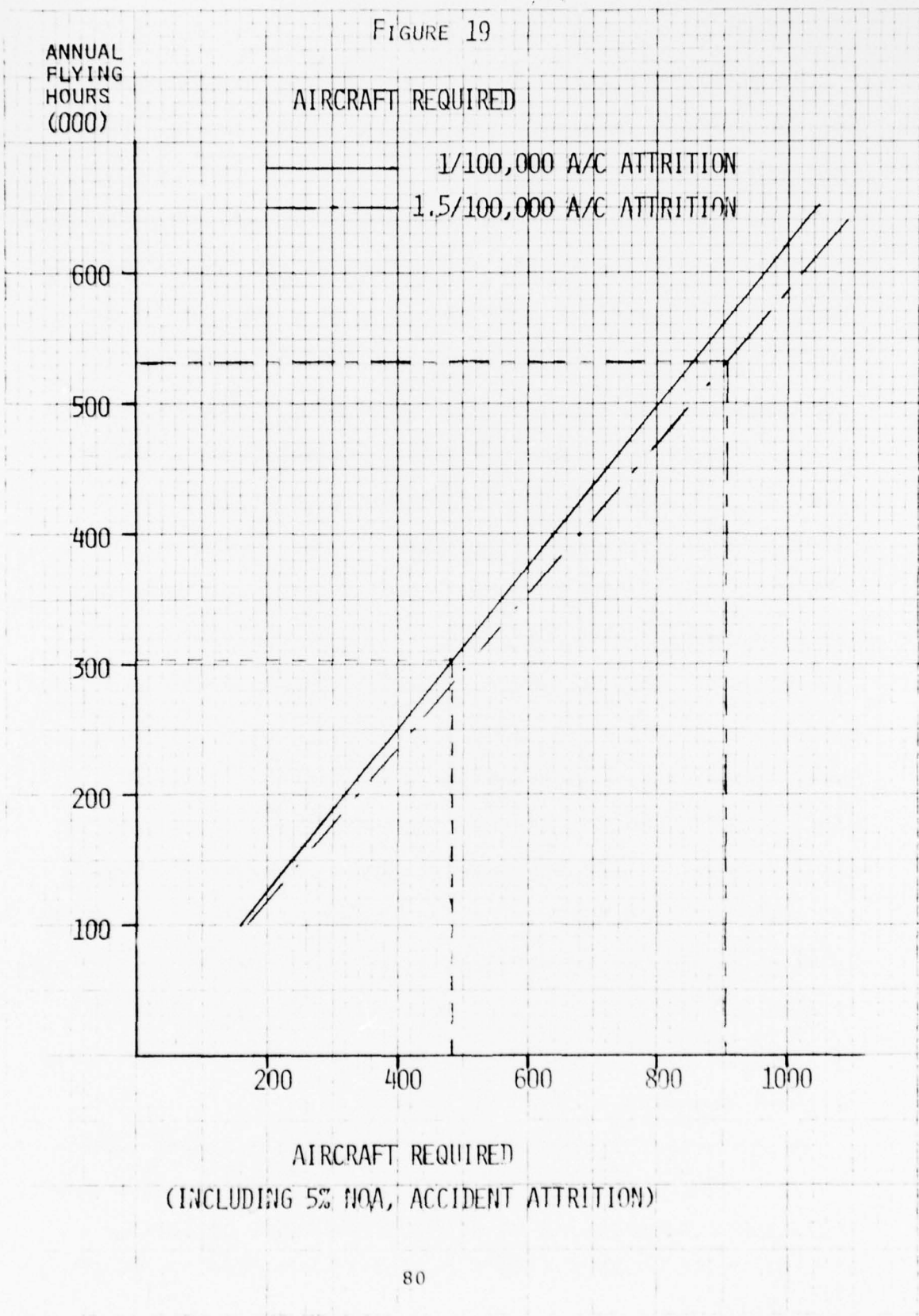

AIRCRAFT REQUIRED  
(INCLUDING 5% NOA, ACCIDENT ATTRITION)

AIRCRAFT PHASE-IN

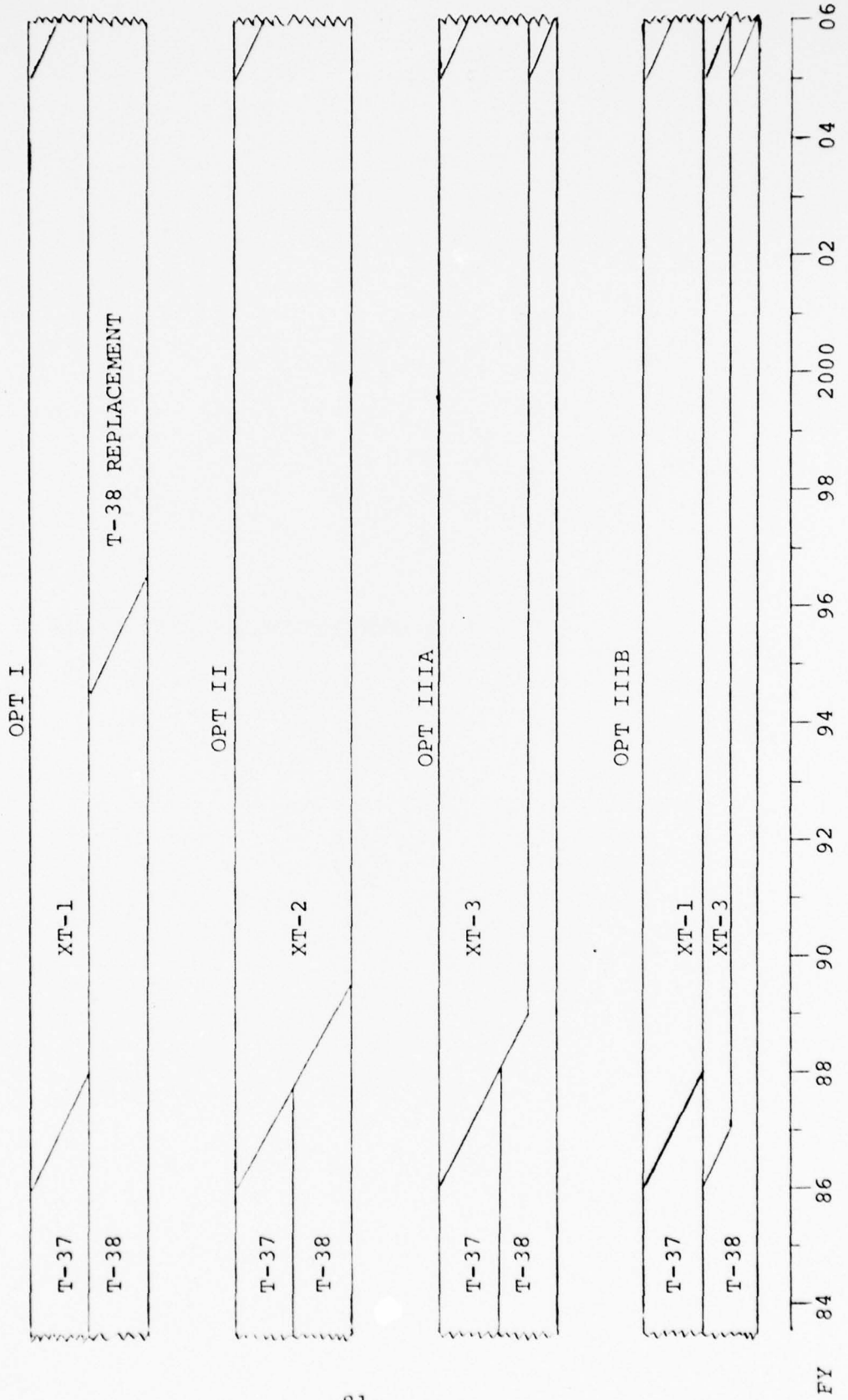

Figure 20

THIS PAGE INTENTIONALLY LEFT BLANK

## VIII. EVALUATION

This section examines the impacts of the selected training alternatives on fleet life, training ability, and costs. Some areas are treated qualitatively as sufficient data is unavailable to permit quantitative analysis.

### Fleet Life Impact of New Systems

Three of the candidate FUPT systems retain the existing T-38 aircraft as a future training vehicle. Once a T-37 replacement has been procured, the T-38 fleet was reexamined for insufficiency dates.

Upon conversion to an XT-1/T-38 UPT system (Option I), a total of 570 T-37 airframes with an average usable remaining life of 2,564 flying hours would exist as excess. This would amount to an equivalent fleet of 97 new T-37 aircraft

$$(570 \text{ A/C} \times \frac{2564 \text{ hrs/A/C}}{15000 \text{ design life}}).$$

Due to a slight flying hour reduction in the T-38 phase of training, the T-38 fleet insufficiency date would be extended by one year to 1995. Therefore, under this alternative, the T-38 fleet would require replacement about halfway through the life cycle of the XT-1.

After conversion to the XT-2 all-through aircraft, Option II, 668 T-38 aircraft, with better than one-third of their usable airframe life remaining, would become excess. This represents 249 equivalent new T-38 airframes. Although several potential uses exist for these excess T-38s, such as foreign military sales, use by Air Defense Command as a T-33 replacement, base support, etc., this still represents a significant loss of utilization.

Conversion to a dual track UPT system (Options IIIA and IIIB) would stretch T-38 fleet insufficiency to 2005, which coincides closely with the life cycle of a T-37 replacement aircraft. Realistically, several of the excess T-38s which would exist at the beginning of a dual track UPT might be assigned non-ATC duties, therefore reducing, to some degree, the revised fleet insufficiency date.

Table 16 summarizes the status of the T-37 and T-38 fleet upon conversion to new aircraft or at the revised fleet insufficiency date in the case of the T-38.

For all of the options described, alternative phase-in programs appear possible, potentially more fully utilizing the remaining T-37 and T-38 fleets.

The dual track options provide two distinct advantages: (1) significantly extend T-38 fleet life, and (2) more fully utilize airframe design life.

Table 16

## T-37/T-38 FLEET STATUS

<u>T-37 Fleet</u>	<u>XT-1</u>	<u>XT-2</u>	<u>XT-3</u>
#T-37 remaining after conversion	570	486	548
Hrs/T-37 on remaining aircraft	2564	2334	2453
Equivalent new T-37 airframes	97	76	90
<u>T-38 Fleet</u>			
#T-38 remaining after conversion*/insufficiency	575	668*	340
Hrs/T-38 on remaining aircraft	2122	5956*	1549
Equivalent new T-38 airframes	76	249*	33
Revised T-38 insufficiency date	1995	--	2005

Training Requirements

Of the 30 numbered training requirements, each alternative is capable of satisfactorily fulfilling numbers 1-19, 21-23, 29 and 30. The remaining six training requirements (TR) require some additional discussion.

Tactical Formation (TR #20). This training requirement can be met effectively only in a specialized training system. Although it could be taught in a generalized UPT system, it would be of little value to those graduates assigned to TTB aircraft. This would increase the length and cost of training.

Basic Fighter Maneuvers (TR #24). See Tactical Formation.

Air-to-Ground Fundamentals (TR #25). See Tactical Formation.

Air Drop Fundamentals (TR #26). Same rationale as in Tactical Formation, but would be of little value to FAIR graduates rather than TTB graduates. Effectively trained only in a specialized UPT system.

Radar Navigation (TR #27). This requirement can be satisfactorily met through the use of ground based media. Airborne radar equipment would add to the acquisition and operating costs of not only new aircraft, but would also require modification of the T-38 in those systems retaining that aircraft.

Crew Coordination (TR #28). Satisfactorily taught only in a specialized UPT system. Use of tandem seated aircraft, as in the generalized UPT systems, provides only limited crew coordination training at best.

A specialized pilot training system can definitely fulfill more training requirements more effectively than other systems. However, the three FAIR-oriented training requirements would require the addition of a tactical phase in the FAIR leg of a dual track system and subsequently increased flying hours. The cost of these additional hours is discussed under the costing evaluation. A more detailed discussion of training systems versus training requirements is contained in the Mission Analysis and Dual Track studies.

A summary of ability to fulfill training requirements is depicted in Table 17. It shows that the basic question relative to training requirements remains unchanged from the Mission Analysis, namely: If 26 training requirements are adequate, then either of the first two generalized options (XT-1/T-38 or XT-2) shown in Table 17 will suffice; if the higher quality of a 30 requirement UPT system is desired, then a specialized system, depicted by the last two columns (XT-3 and T-38) will be needed.

#### Qualitative Assessment

This section presents pros and cons for each of the alternative training systems. Many areas are, by nature, unquantifiable; however, in some cases, a lack of data has dictated a qualitative treatment.

XT-1/T-38 System. The major advantage of this system is its low initial investment cost. This provides a potential advantage in obtaining necessary funding. Over the life cycle of such an aircraft, however, the cost of operating the relatively expensive T-38 makes this system a poor alternative. Furthermore, the T-38 aircraft would require replacement only a few years after introduction of the XT-1.

Table 17  
 CANDIDATE SYSTEMS VS TRAINING REQUIREMENTS

<u>Training Requirements</u>	<u>XT-1/T-38</u>	<u>XT-2</u>	<u>XT-3 (TTB)</u>	<u>T-38 (FAIR)</u>
1. Ground Operations	X	X	X	X
2. Pre-Takeoff Taxi	X	X	X	X
3. Takeoff	X	X	X	X
4. Formation Takeoff	X	X	X	X
5. Climb/Level Off	X	X	X	X
6. Descent/Approach	X	X	X	X
7. Landing	X	X	X	X
8. Post-Landing Taxi	X	X	X	X
9. Basic Control	X	X	X	X
10. Precision Control	X	X	X	X
11. Departure Recognition & Recovery	X	X	X	X
12. Aerobatics	X	X	X	X
13. Unusual Attitudes	X	X	X	X
14. Pilotage/Dead Reckoning	X	X	X	X
15. High/Low Altitude Nav	X	X	X	X
16. Close Formation	X	X	X	X
17. Trail Formation	X	X	X	X
18. Communications	X	X	X	X
19. Emergency Procedures	X	X	X	X
20. Tactical Formation				X
21. Formation Landing	X	X		X
22. Low Level Visual Nav	X	X	X	X
23. Decision Making	X	X	X	X
24. Basic Fighter Maneuvers				X
25. Air/Ground Fundamentals				X
26. Air Drop Fundamentals			X	
27. Radar Navigation**	X	X	X	X
28. Crew Coordination	X*	X*	X	X*
29. Collision Avoidance	X	X	X	X
30. Airborne Rendezvous	X	X	X	X

\* Satisfactorily taught only in specialized UPT due to limitations of tandem seating.

\*\* Possibly accomplished via Ground Based Training.

This system may present less risk by preserving the "status quo" in that it retains the current universally assignable pilot concept as well as retaining aircraft similar to the current T-37/T-38 system.

XT-2 System. The major advantage of this system lies in its ease of support, both in logistics support and operations support. Several potential advantages are discussed below:

1. Reduce syllabus flying hours by eliminating need to transition between aircraft. Although this is probable, the reduced total hours could be more costly due to the increased complexity of the aircraft in comparison to a low cost primary aircraft.

2. Eliminate associated general lack of knowledge during transition period. Many consider the transition experience a valuable part of UPT.

3. Standardize and simplify maintenance. Although standardization in procedures and ground support equipment would result, simplification would mainly apply only in the management areas (training, scheduling, etc.).

4. Negate the necessity for multiple departure and arrival routes, thus decreasing possible conflict areas with ATC aircraft and civilian aircraft. Although recognizing a reduction in conflict areas, it must be noted that most ATC accidents are not the result of mid-air collisions between dissimilar aircraft.

5. Allow all training to be accomplished in the same training areas. This would probably reduce the airspace required to conduct UPT training and thus further reduce the mid-air collision potential. Primarily, this would ease management of training areas; however, the higher performance of the XT-2 would require enlargement of the existing T-37 training area size, thus reducing the number of available areas. Some reduction in T-38 area size could be accomplished. Thus it appears that there would be little, if any, net reduction in training area airspace.

6. At three runway bases, it would allow one runway to be used for VFR patterns, one for departure and arrivals, and one for IFR training. This procedure could curtail and possibly eliminate the requirement for satellite GCAs, IFR training at other bases, and auxiliary airfields. Again, this would reduce mid-air collision potential and lend to a safer environment because of fewer procedures and improved command and control. Note that satellite GCAs will be eliminated with implementation of the Instrument Flight Simulators.

7. Reduced operations and maintenance personnel, primarily in fixed overhead. Although probable, the reduction would be quite minimal. The number of students would probably require two training squadrons per wing. Maintenance manpower is now computed on the basis of flying hours

and manhours per flying hour. Although some potential reduction in maintenance support functions appears attainable, the added complexity of an XT-2 versus T-37 (or other primary aircraft) could result in a net increase in manpower.

8. Reduced academic course length.

9. Reduce PIT from two to one squadron. This again would primarily depend upon student load and is not necessarily true.

10. Reduced maintenance training requirements. This also is a function of the manhour/flying hour ratio. A reduction in total number of different types of training courses and training equipment would result; yet the number of instructors and total number of classes remains substantially unchanged.

11. Reduced flying hours/experience of UPT graduates. Career milestones are often pegged to total flying time. Reduced UPT hours could require more experience be gained later in more expensive (cost per flying hour) aircraft in order to upgrade.

12. Increased time in one aircraft should increase confidence, experience level, and graduate quality. This appears likely if the total UPT flying hours per student remains unchanged from a two aircraft generalized pilot training system. However, one of the main advantages to

a single aircraft system is the ability to reduce total syllabus flying hours and maintain graduate quality (item #1). However, you cannot have it both ways.

13. An all-through aircraft could be easily adapted to fulfill a light attack/fighter trainer mission. The foreign sales potential could result in a lower unit cost per aircraft than used in this study. Since the XT-2 would also replace the T-38 fleet, a certain sales potential of T-38 aircraft is also realized under this option.

Perhaps the major advantage of the single aircraft concept as a replacement for the current trainer mix is in the improved fuel economy of the XT-2 versus the T-38 due to advanced technology and somewhat reduced performance requirements. For the generalized pilot training option, i.e., universally assignable pilot concept, the XT-2 concept has a definite advantage over multiple aircraft systems retaining the (relatively) expensive T-38.

#### Specialized UPT Systems

In contrast to a generalized UPT system, a specialized (dual track) system can meet more training requirements more effectively, thereby producing a higher quality graduate. This point has repeatedly been discussed in a number of previous studies and articles.

Although tracking is seen to produce a higher quality graduate, some disadvantages are also clearly evident. Assignment flexibility, both for initial assignment and during one's career, is reduced. The degree to which this flexibility is desired or required is not considered during this study, but should be considered prior to any final decision.

Of greater concern to the training community is the impact of specialization on training resources. For any given pilot production level and distribution of FAIR/TTB assignments (currently about 40%/60%) a given number of FAIR/TTB aircraft are required. Should pilot requirements change substantially from this planned distribution, one runs the risk of having too few of one trainer aircraft and too many of the other. By retaining the T-38 as the FAIR trainer, this risk is considerably minimized, due to the large size of the existing T-38 fleet. This acts as a comfortable buffer should assignment distribution favor the tactical aircraft forces. It is important to realize that although an apparent excess of T-38 aircraft will exist if a specialized UPT system is adopted, maintenance of this buffer must be considered whenever potential reductions in the T-38 fleet are contemplated, such as foreign sales, transfer, etc.

The next paragraphs deal, qualitatively, with advantages of a one versus two new aircraft buy in support of a specialized UPT system.

XT-3/XT-3/T-38 System.

1. Requires purchase of only a single new aircraft (possibly easier to obtain funding).

2. Limits UPT to a two aircraft system with subsequent ease of logistics support. With TTB and FAIR tracks conducted at different bases, it allows the single aircraft advantages regarding airspace utilization and reduced mid-air collision potential to be incorporated at the TTB bases.

3. Would require the XT-3 to be designed primarily for training, i.e., very limited use for cargo or passenger handling.

XT-1/XT-3/T-38 System.

1. Lower O&M costs compared to XT-3 only.

2. Increased logistics support required to maintain three aircraft.

3. The XT-3 could be enlarged somewhat to allow for passenger and/or cargo handling. This would increase the cost both in acquisition and O&M. Little increased training would be achieved. An enlarged XT-3 could possibly replace the aging MAC T-39 fleet, thus reducing overall unit cost. Potential as a civilian executive jet could further reduce the cost of acquisition.

XT-1/Executive Jet/T-38. This is substantially the same as the previous system but envisions use of existing business or executive jet aircraft in lieu of the XT-3. Detailed analysis of this option is deemed inappropriate at this stage.

Qualitatively:

1. Would allow conversion to dual track UPT more readily (off-the-shelf aircraft).
2. Would provide a potential replacement for aging MAC T-39.
3. Potentially lower acquisition cost due to reduced RDT&E.
4. Increased O&M cost over XT-3 due to larger size, less current technology.
5. No identifiable training advantage in an executive jet versus XT-3.

#### Syllabus

The three syllabi previously depicted in Figure 12 and Table 13 should provide equivalent graduate quality. The dual track option, however, provides the ability to better tailor the graduate for his end assignment. Any substantial increases in syllabus hours in order to increase graduate quality provide an opportunity for reduced post-UPT training. In the case of graduates selected for FAIR assignment, increased UPT time and training in the T-38 could result in

reduced TAC lead-in training. Since the T-38 is used in both courses, costs would remain substantially unchanged with some potential reduction in fixed costs. Any reduction in TTB graduate post-UPT flying training as a result of increased graduate quality should significantly reduce overall training costs due to the relatively high cost of operating multi-engine operational aircraft. Extensive testing and validation would be required to determine the amount of tradeoff which could be effected. This study does not address these tradeoffs, but a table of operational aircraft flying hour costs is provided in Table 18. When compared with data on FUPT Options in Table 15, the conclusion is obvious.

#### Cost Analysis

A cost analysis was performed with basic data provided in Appendices I & J. The objective of this cost analysis was to provide management with indicators of the relative cost ranking of the various UPT alternatives. Therefore, procedures were adopted which would allow the development of a rank-ordered costing without the constraints of a formal Life Cycle Costing (deemed inappropriate at this stage). The major areas of cost which are sensitive to system design and training concept have been included (RDT&E, aircraft acquisition, simulator modification, fuel, and maintenance); however, several wash items have been excluded as they do not affect the relative rank order.

Table 18

## Operational Aircraft Flying-Hour-Cost Factors (FY 1977 Dollars)\*

Aircraft M/D/S	Fuel	Depot Maint	Maintenance Material	Replenishment Spares	Base Labor	Total per A/C
A7D	\$ 297	\$ 387	\$ 115	\$ 225	\$ 415	\$ 1439
B52H	1468	546	341	275	1008	3638
FB111A	611	461	429	450	1006	2957
C5A	1496	1236	450	428	1004	4614
Cl30H	340	142	96	85	299	962
Cl41A	877	162	149	84	331	1603
F4D	628	210	139	178	946	2101
F15A	552	274	164	494	533	2017
KCl35A	1046	226	156	117	651	2196

\* Extracted from Table 1A AFM 173-10 Vol I (C5) 20 January 1977.

The O&M costs depicted in this analysis exclude all fixed and some variable costs such as student and instructor pay and their associated BOS. A per flying hour cost was computed for each aircraft which included the following elements: Maintenance labor (salary), maintenance materials, replenishment spares, depot maintenance, AVPOL, BOS personnel and non-personnel costs associated with the maintenance labor force. Listed below are these computed flying hour costs for each aircraft:

T-37	\$258
T-38	504
XT-1	173
XT-2	282
XT-3	237

The O&M costs used in this analysis multiplied annual flying hours by the appropriate cost per flying hour.

In addition to the O&M costs derived above, RDT&E, aircraft acquisition, and simulator modification costs were used in the development of rank-ordered costings used in this study. Investment dollars were considered expended in FY 84 to FY 86.

Cost Category Rankings. Table 19 summarizes the cost data developed in Appendix I. The data is broken down by major cost categories: RDT&E, acquisition, simulator, and O&M. A credit is included for the residual value of current UPT aircraft upon conversion to a follow-on UPT system or, in the case of Option I, the value of a T-38 replacement aircraft at the end of the XT-1 service life. These costs are totaled and provided in terms of constant 77 dollars, current (then year) dollars, and discounted dollars.

Purely for illustration purposes, costs are depicted for the existing system as Option 0. This is not a possible alternative as the existing T-37/T-38 system cannot be sustained forever. It is provided only as a reference base.

Making a decision based on these cost categories alone is difficult because most of the costs are within 10% of each other. However, a few points are worth mentioning in analyzing Table 19 data:

a. Option I has the highest investment cost due to the need to replace the T-38 midway through the life time of the XT-1 (T-37 replacement). Cost data for the XT-2 were used to estimate costs for this T-38 replacement. Since half of the T-38 replacement aircraft

Table 19

## COST BREAKDOWN - \$M

	OPTION				
	<u>O*</u>	<u>I</u>	<u>II</u>	<u>IIIA</u>	<u>IIIB</u>
RDT&E		91	223	163	91
	**	223			163
Acquisition					
- Simulators		70	68	56	61
- Aircraft		<u>1,010</u>	<u>1,022</u>	<u>744</u>	<u>655</u>
Total Investment		1,394	1,313	963	970
(Residual Value)		(346)	(192)	(43)	(44)
O&M	5,364	4,065	3,754	4,283	3,794
<u>Totals</u>					
Constant 77 \$	5,364	5,113	4,875	5,203	4,720
Current (then year) \$	20,012	15,728	15,356	17,178	15,383
Discounted \$	6,165	6,248	6,074	6,370	5,803

\* Existing system depicted only for illustration.

\*\* T-38 replacement in 1995 based on XT-2 costs.

life would be remaining at the end of the 20 year system life, Option I also has the highest residual value. The high investment costs, coupled with a high O&M cost, makes Option I one of the higher cost systems.

b. Option II has the highest initial investment cost due to replacement of both the T-37 and the T-38 fleet at the same time. Since the T-38 is replaced, this system has a low operating cost; therefore, making it one of the lower cost systems.

c. Although Option IIIA has the lowest investment cost, it also has the highest O&M cost, making it a high cost system.

d. Option IIIB has both a low investment cost as well as a low operating cost, making it the lowest cost system.

Average Annual Value. Based on the detailed cost data in Appendix I, Table I compares these types of costs with and without residual value (e.g., the estimated value of useful life remaining in the residual T-37 fleet when phased out). These costs included all system-dependent cost elements (RDT&E, acquisition, operations, and maintenance) and were averaged over 23 years (three years phase-in plus 20 years utilization) to provide the average annual value (AAV) in the table. Flying hours were based on extrapolation of all current programs (UPT, PIT, SAPT, ETC.) with the exception of GAF, ACE, and UNT.

Because of the uncertainty associated with projecting programs (much less their costs) 30 years into the future, and because of the difficulty in making approximations for converting the non-USAF programs into their "USAF equivalents" (see Appendix H and Section IV), it was deemed appropriate to remove as much of this uncertainty as possible. Furthermore, reimbursement for SAPT training costs was not included. Determining the residual value of an aircraft system even 10 years hence becomes difficult.

Therefore, costs like those in Table I, Appendix I, were recomputed for only USAF program projections and without residual values. A rank-ordering of these costs is shown in Table 20. The existing system (Option 0) is again provided for illustration purposes only. Although costs are still relatively close, Option IIIB is again seen to be the lowest cost option.

Per Graduate (Unit) Cost. A cost per graduate for each FUPT option was computed. These costs include all variable costs (direct and indirect) but exclude fixed overhead costs and system acquisition costs. These costs were computed in constant FY 77 dollars and based on cost factors listed in Table 15. As depicted in Figure 21, the single aircraft and dual-track options are less costly than

Table 20

RANK ORDERED COST - \$M

	<u>Constant \$</u>	<u>Current \$</u>	<u>Discounted \$</u>
Existing System:			
0 - T-37/T-38	204.443	762.751	234.953
Generalized UPT Options:			
I - XT-1/T-38	215.225 (4)	704.634 (4)	258.955 (4)
II - XT-2	202.023 (3)	623.167 (2)	249.164 (2)
Specialized UPT Options:			
IIIA - XT-3/T-38	198.419 (2)	639.606 (3)	255.483 (3)
IIIB - XT-1/XT-3/T-38	180.229 (1)	573.291 (1)	223.907 (1)

(Rank Order) - 1 = lowest cost; 4 = highest cost

FIGURE 21

COST PER GRADUATE COMPARISON  
(VARIABLE COSTS ONLY)

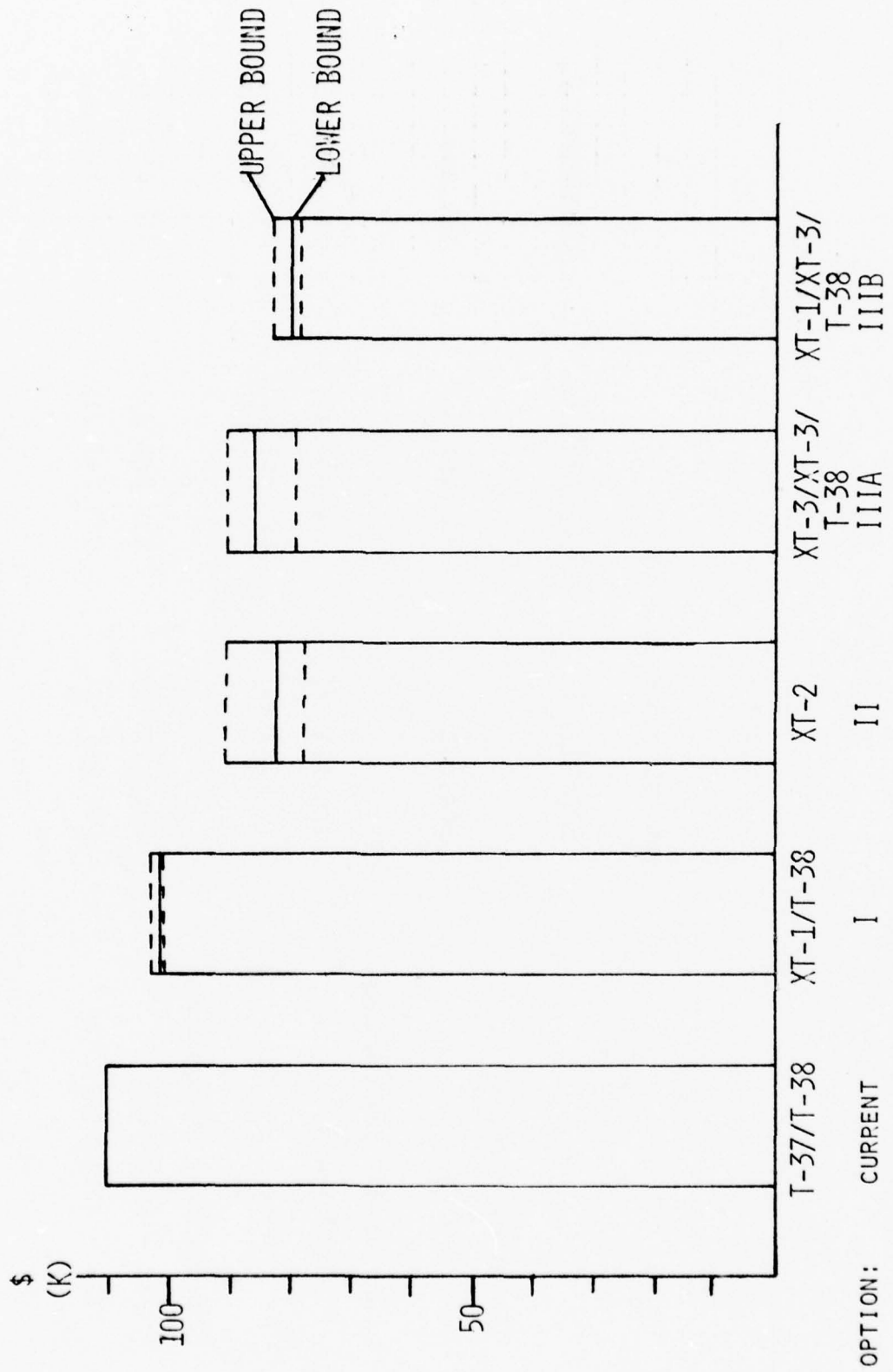

either the current program or a straight T-37 replacement. The specialized Option IIIB UPT system using three aircraft (XT-1/XT-3/T-38) again has the lowest cost.

The dashed lines in Figure 21 provide upper and lower bounds for cost per graduate when using the upper and lower bounds for various flying hour cost factors from Table 15. Again the XT-1/XT-3/T-38 system remains the lowest cost option.

#### Fuel Considerations

Fuel costs and availability have been of ever increasing concern. Figure 22 reflects fuel consumption rates for each option as well as the current system using IFS. The left-hand vertical axis represents fuel required to produce one UPT graduate, including attrition and overhead. The right-hand axis is scaled to depict total fuel required annually to produce 2100 UPT graduates.

The figure graphically portrays the effect of retaining the T-38 with its relatively high fuel consumption rates. There is some reduction in Option I since some hours now flown in the T-38 are put in the XT-1. Those systems which replace the T-38 in whole or in part show a distinct fuel advantage. The T-38 portion of the specialized Options IIIA and IIIB is reduced since only about 40% of UPT production go through the FAIR track.

FIGURE 22

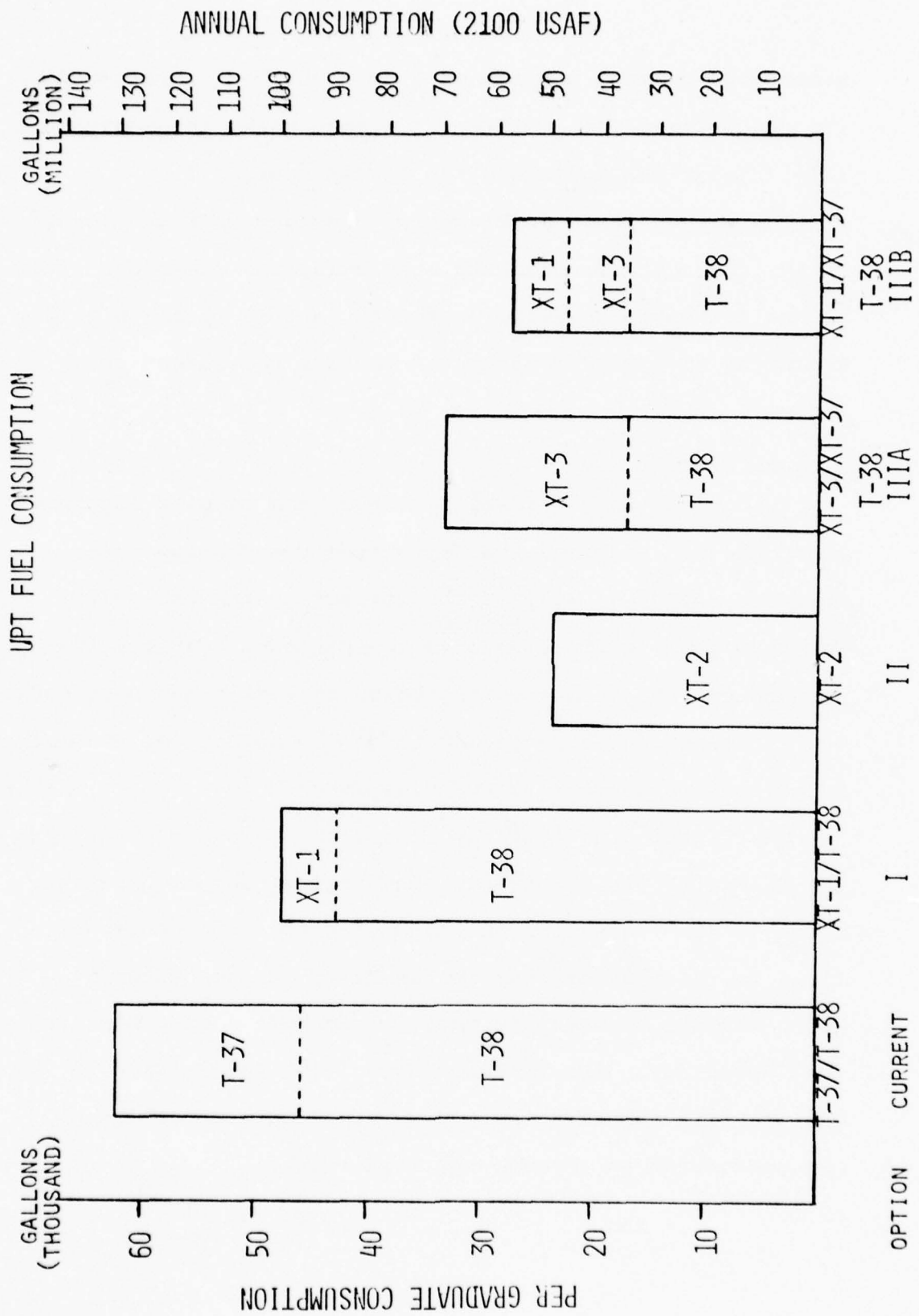

### Additional Training Impacts

The fuel and cost details provided so far have been predicated on a constant quality graduate. In the case of the all-through option (Option II) considerable discussion has favored not reducing student flying hours but, rather, using this time to improve graduate quality. Retaining a syllabus of 171.8 hours per student will increase the annual flying hours, cost per graduate, fuel consumption, and the total number of new aircraft required. Although ATC costs would increase over the shorter 154.1 hour program, the increased graduate quality should be reflected in reduced post-UPT follow-on training and a subsequent reduction in overall USAF costs. The degree of tradeoff is not addressed in this study.

Similarly, under the specialized UPT options (Options IIIA and B), the addition of a tactical phase in the FAIR track has considerable appeal. Adding a short tactical phase (12 sorties/13.2 hours) would also increase annual flying hours, per graduate costs, and fuel consumption. However, rather than requiring purchase of additional aircraft, a one year reduction in T-38 fleet life would occur (from 2005 to 2004). Assuming that any increases in the FAIR syllabus would be compensated for by reduced TAC lead-in training (also using the T-38), overall USAF costs should remain relatively constant.

Table 21 summarizes the impact of providing this additional training in some of the more significant areas. Since the type and amount of additional training varies among the three options, this table is not intended for use as a comparison of alternatives. All totals are given in the context of Table 20 and Figures 21 and 22.

Table 21

## IMPACT OF ADDITIONAL TRAINING

<u>Incremental Changes</u>	<u>II</u>	<u>IIIA</u>	<u>IIIB</u>
Sorties/hours per student	13/17.7	12/13.2 (FAIR Only)	12/13.2 (FAIR Only)
Additional annual flying hours	48,493	14,639	14,639
Additional fuel consumption (million gal/yr)	5.7	5.2	5.2
Additional O&M costs per year (FY 77 \$M)	13.7	7.4	7.4
T-38 fleet life reduction	--	1 Year (2004)	1 Year (2004)
Additional A/C required (incl attrition)	83	--	--
Unit cost per aircraft (FY 77 \$M)	.803	--	--
<u>Revised Totals</u>			
Cost per graduate (FY 77 \$M)	.089	.089	.083
Average annual value (\$M)			
Constant \$	215.625	204.624	186.965
Current \$	674.698	665.060	599.750
Discounted \$	264.546	262.230	231.417
Annual fuel consumption(m/gal)	55.0	75.0	62.6

### Sensitivity Analysis

Two key factors have dominated the comparison of alternatives to this point: production levels and syllabus construction. These factors significantly affect fleet life, procurement size, system cost, and per graduate cost. This section examines the potential effects of changes to various system elements.

UPT Production Level vs Fleet Insufficiency. Any substantial change in Air Training Command production rates affects fleet insufficiency dates as depicted in Figures 7 through 10. Note that each 25,000 hour decrease in annual T-37 flying hours adds approximately one year to T-37 fleet life expectancy (25,000 hours roughly equates to 275 UPT graduates). Similarly, a 20,000 hour annual increase in flying hours shortens fleet life by six months (for the first 40,000 hours or one year). Further increases in annual flying hours accelerate the rate of fleet insufficiency due primarily to an inadequate fleet size. Sale or transfer of ATC T-37 aircraft also reduces fleet life by approximately six months for every 25 aircraft transferred or sold.

Numerous programs at various stages of development (NJJPT, foreign sales, etc.), if brought to fruition, seriously accelerate fleet insufficiency and drastically reduce the available lead-time necessary for a new

procurement of aircraft. Similarly, a reduction in the ACE program, SAPT, and/or UPT production levels could be used to extend remaining fleet life, providing short-term increases in lead time.

A similar situation exists in the T-38 fleet. In fact, if all "what if" programs were instituted, a serious shortfall in T-38 aircraft would exist. However, this is a problem of utilizing existing resources and is independent of aircraft age.

Since the T-38 is a newer aircraft, its retirement date is several years after that of the T-37. Nevertheless, changes in syllabi and production rates affect its retirement date. Figure 23 depicts, parametrically, the revised T-38 fleet insufficiency date as a result of conversion to a new UPT system in 1986. The chart assumes already programmed PFT flying hours through FY 81. The curved guidelines reflect annual flying hours from FY 82 through FY 85. The vertical axis represents annual flying hours from FY 86 on. For example, assume an FY 82 to FY 85 T-38 flying rate of 355,413 hours annually. From FY 86 on, under Option I (XT-1/T-38), T-38 hours would be 340,997 hours annually. Enter the vertical axis at 340,997 (dashed line); proceed horizontally to 355,413 (between 350,000 and 400,000 hours guidelines); drop vertically to

FIGURE 23

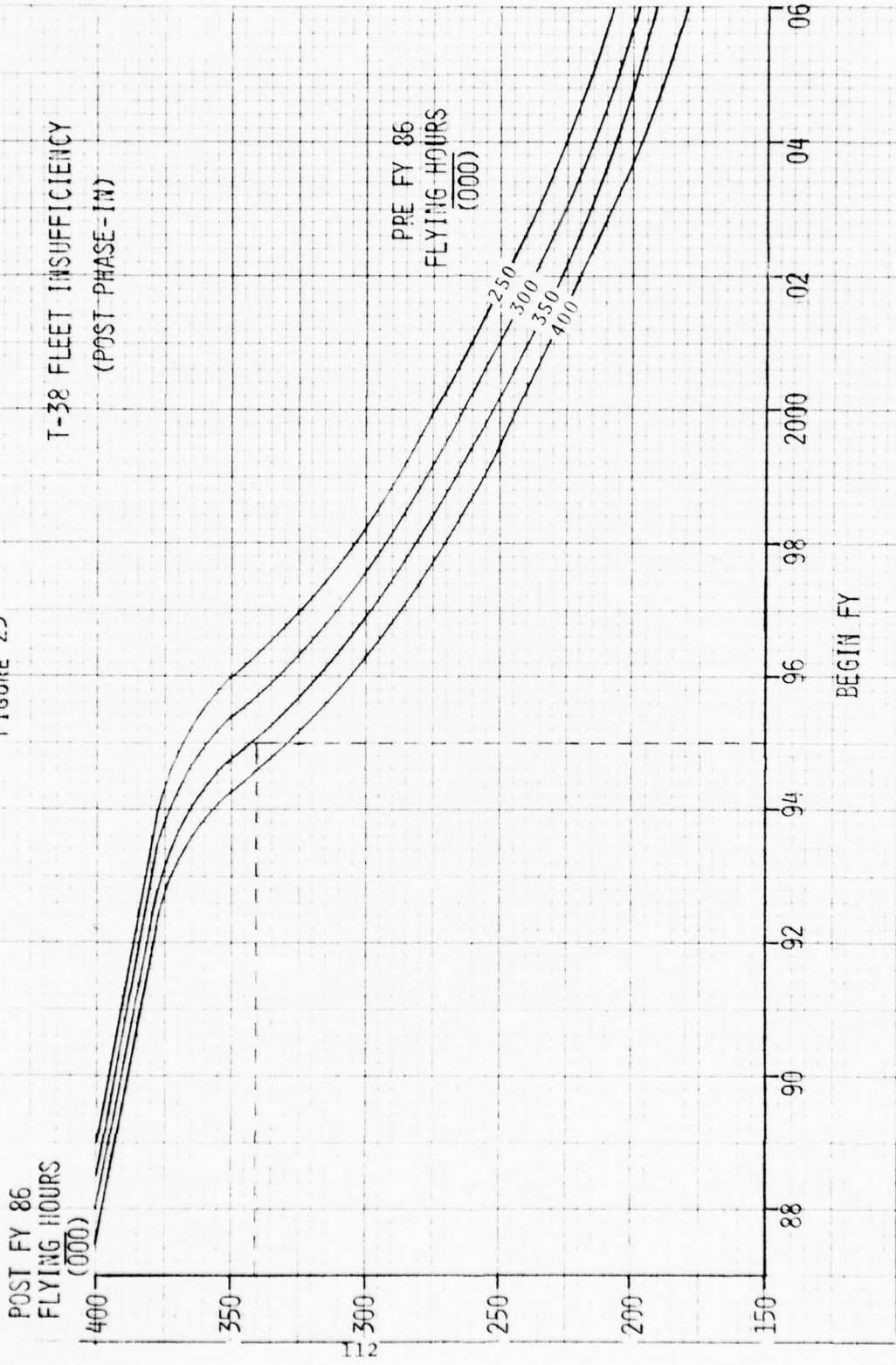

the revised T-38 fleet insufficiency date of 1995. In this case, an additional year (1994 to 1995) has been gained over current UPT insufficiency dates since the Option I syllabus reduces some T-38 phase hours with some increase in XT-1 phase hours versus those being flown in the T-37 phase.

NOTE: Figure 23 is based on a single change in annual flying hours occurring in FY 86 and does not take into account a more gradual reduction in T-38 flying hours as experienced under the dual track options. In such cases the revised fleet insufficiency date would occur slightly earlier than when read directly from Figure 23. For example, if T-38 hours were reduced from 350,000 to 198,000 over a three year period, the post phase-in insufficiency date would have to be revised downward from 2005 to 2004.

Cost Sensitivity. The sensitivity of costs was examined in relation to the following variables:

- (1) Syllabus flying hours per student
- (2) Total annual ATC flying hours
- (3) Aircraft acquisition costs
- (4) Aircraft per hour operating costs.

A baseline was established with the following:

- (1) UPT annual production of 2100 USAF pilots
- (2) Total ATC flying hours for each option from

Tables 23 through 26 (Appendix H)

(3) Aircraft acquisition costs as depicted in Figure 18

(4) Aircraft operating costs as shown in Table 15.

Each candidate system was then assigned a baseline dollar value by computing the flying hours required to produce one graduate (including student attrition and overhead flying) and multiplying by the cost per flying hour. Added to this was the proportionate cost of new aircraft per graduate, including aircraft attrition. The total procurement level was determined by the total annual command flying hour requirements.

Each major variable was then adjusted by  $\pm 5\%$  increments from 0 to  $\pm 25\%$  and a new dollar value computed. For example, for an iteration of  $+5\%$ , aircraft acquisition costs were increased by  $5\%$ . Also, syllabus hours per student were increased by  $5\%$  as was the operating cost per hour. Total command flying hours were also increased by  $5\%$ . This increased the aircraft procurement level and a buy was made at that level. A new dollar value was then computed. This process was repeated in  $5\%$  increments from  $0\%$  (baseline) to  $\pm 25\%$ . The results were then plotted as Figure 24.

Interestingly the system curves in Figure 24 are not parallel and therefore do not retain their relative rank ordering over the interval under the treatment described

FIGURE 24  
SENSITIVITY OF COSTS  
AWAY FROM BASELINE

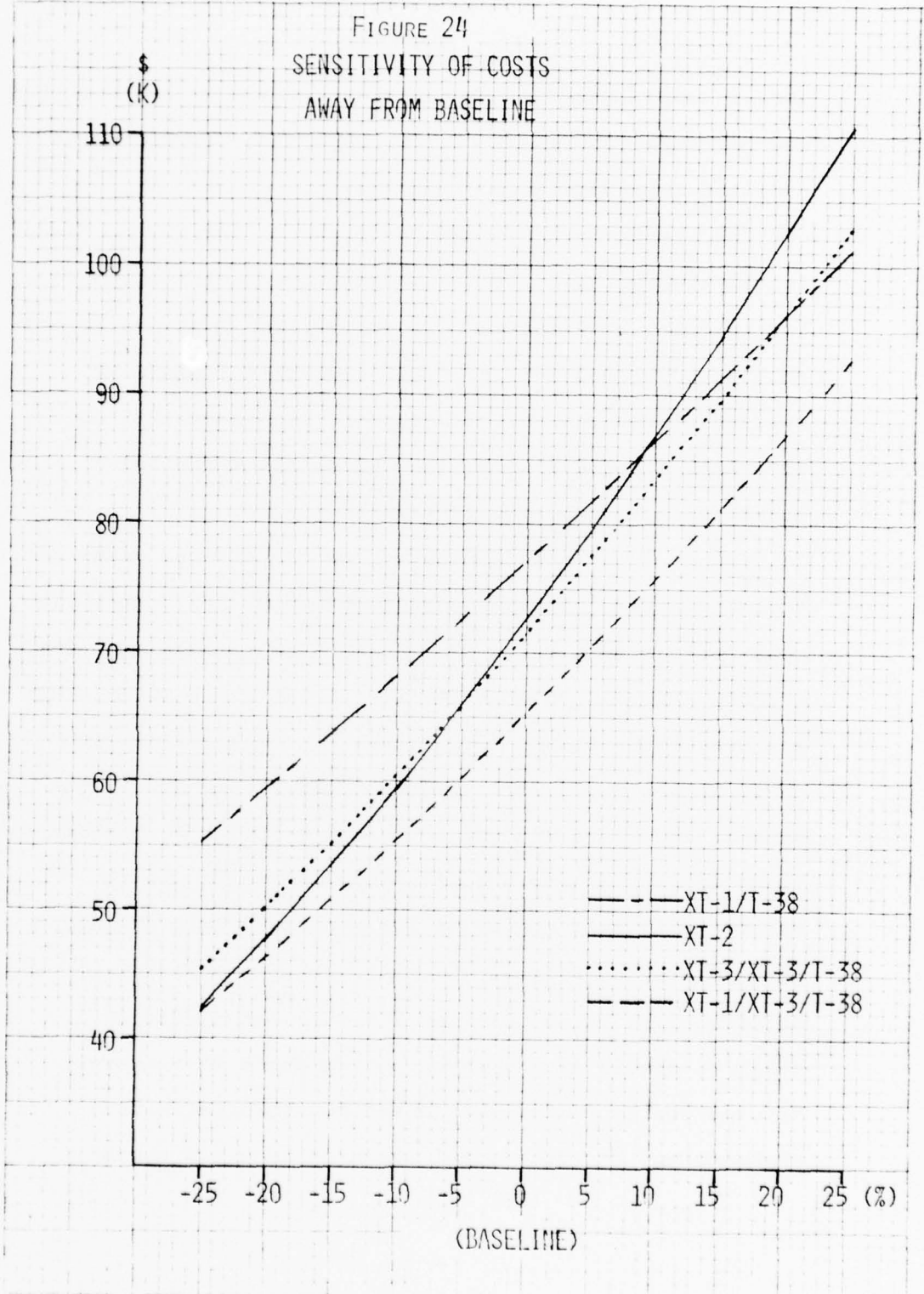

above. Note, however, that the dual track system with two new aircraft (Option IIIB) does remain the lowest curve over the interval.

The treatment above uses a constant increase or decrease in all the variables, whereas this may not actually occur. For example, a 5% increase in acquisition cost may be offset by a 3% reduction in hourly operating costs with syllabus hours remaining unchanged. Consequently, some additional charts are provided which allow further parameterization by the interested reader.

Figure 25 allows examination of the effects of syllabus hours, aircraft operating costs, and aircraft acquisition costs on the unit value described in the preceding paragraphs. The dashed example line is for illustration only and does not reflect any particular option. Enter the chart in the upper left quadrant at syllabus hours per student (90 hours/student in example); parallel the guidelines until reaching primary phase attrition (10%); horizontally until entering basic phase attrition; then parallel the guidelines (5% basic phase attrition); horizontally, until entering the overhead flying rate (15%) to obtain flying hours per graduate (115 hours). Proceed horizontally until entering the upper right quadrant and continue until reaching aircraft operating

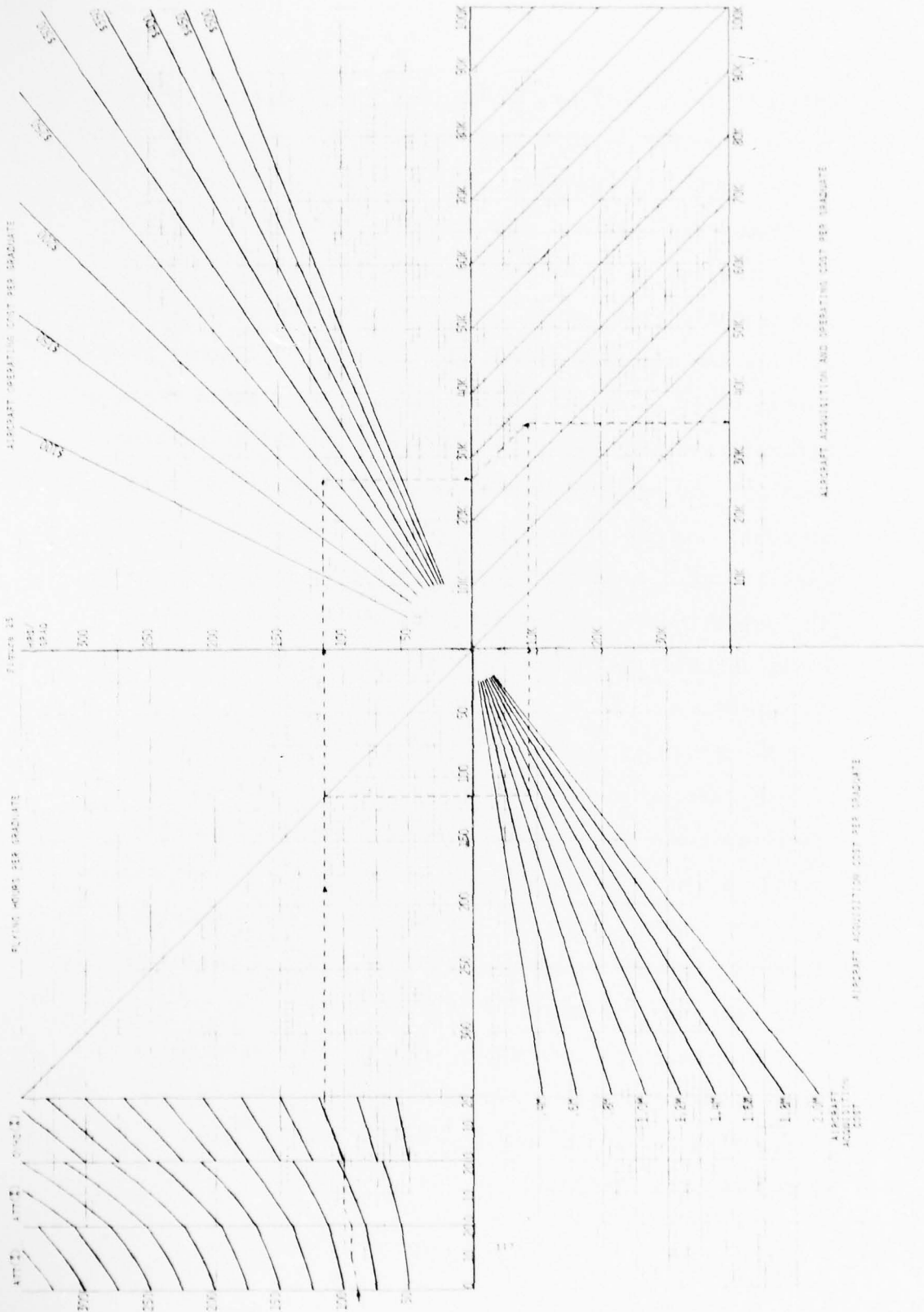

cost per hour (\$230 per hour); then vertically to obtain aircraft operating cost per graduate (\$26,450). Returning to the upper left quadrant, where flying hours per graduate were obtained (115 hours), drop vertically from the guideline to enter the lower left quadrant at hours per graduate (115 hours); continue vertically until intersecting the aircraft acquisition cost (\$1 million); proceed horizontally to obtain the graduate proportionate share of aircraft acquisition costs (\$8,817). In the lower right quadrant the per graduate aircraft acquisition cost is added to the per graduate aircraft operating cost by entering at the operating cost (\$26,450) and paralleling the guidelines until intersecting the acquisition cost entry (\$8,817) to obtain a total unit value per graduate (\$35,267).

As described in the example above, the chart provides a unit value per graduate for the primary phase of a two phase system. To use the chart to compute values for either a single phase system or the basic (second) phase of a two phase system use the desired phase attrition immediately after entering the chart. Use a zero attrition rate for the second attrition value.

As with other cost data, this method allows for a comparison of relative change between options due to various factors, and does not purport to represent absolute cost changes.

In summary, it can be seen that a myriad of variables exists which could be examined as part of this effort. Sensitivity to aircraft costs and flying hours, considered to be two of the more significant variables, was examined. Results indicate that Option III B would remain the lowest cost alternative.

THIS PAGE INTENTIONALLY LEFT BLANK

IX. FINDINGS

1. The aging T-37 fleet will become insufficient to sustain projected flying training requirements by 1988.
2. Potential future programs will accelerate fleet insufficiency.
3. *Cont. Program* → Training requirements for UPT *(Undergraduate Pilot Training)* will be substantially unchanged in the future, with the emphasis remaining on the acquisition of basic flying skills.
4. A specialized pilot training system is required to effectively teach the 30 identified training requirements.
5. Procurement of new aircraft is required to replace the T-37 and inaugurate specialized pilot training.
6. T-38 fleet life can be extended ten years by conversion to a specialized UPT system.
7. Acquisition and life cycle costs favor a three aircraft specialized UPT system; a primary aircraft replacement for the T-37, a new *(Tanker-Transport-Bomber)* TTB trainer, and use of the T-38 as a FAIR *(Fighter-Attack-Interceptor-Reconnaissance)* trainer.
8. Regardless of which FUPT alternative is chosen, the decision must be made in the near future to allow for the lengthy acquisition cycle and processes.

THIS PAGE INTENTIONALLY LEFT BLANK

APPENDIX A

USAF/CV Ltr, 21 July 1976 and Response

DEPARTMENT OF THE AIR FORCE  
OFFICE OF THE CHIEF OF STAFF  
UNITED STATES AIR FORCE  
WASHINGTON, D.C. 20330

21 JUL 1976

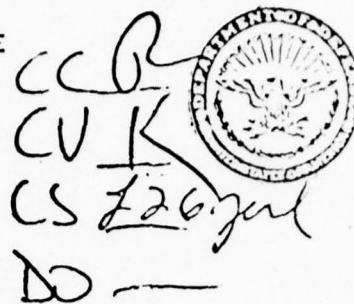

Lieutenant General John W. Roberts  
Commander, Air Training Command  
Randolph AFB TX 78148

Dear John

We have reviewed your study on generalized vs specialized UPT and concur in the recommendation to retain the generalized UPT system.

While operating a Tanker Transport Bomber (TTB) trainer in the dual track system could produce savings, other considerations weigh against adoption of a specialized training system and acquisition of a new aircraft at this time. Whether the UPT concept changes or not, the T-37s will begin reaching their fatigue life in the mid-1980s, and by 1991 there may not be enough aircraft to support UPT at the level we will need. The question at this time is whether to modify the existing T-37 or procure an entirely new aircraft for primary jet pilot training. It may even be advisable to explore the other option identified in the Mission Analysis on Future UPT by replacing both the T-37 and the T-38 with a single aircraft capable of handling the entire UPT mission.

Request ATC explore the various alternatives and develop a plan to replace or modify the T-37 as it approaches the end of its 15,000 hour life. As was done in the dual track study, every avenue for a better, more economically trained graduate should be explored. The thoroughness and excellence of your efforts in this vitally important program are appreciated.

Sincerely

Handwritten signature of William W. McBride.

WILLIAM W. MCBRIDE, General, USAF  
Vice Chief of Staff



DEPARTMENT OF THE AIR FORCE  
HEADQUARTERS AIR TRAINING COMMAND  
RANDOLPH AIR FORCE BASE, TEXAS 78148



5 AUG 1976

General William V. McBride  
Vice Chief of Staff  
Headquarters USAF  
Washington DC 20330

Dear General McBride

My staff has been directed to study the three generalized pilot training options addressed in your letter of 21 Jul 76. As in the Dual-Track study, we will consider all pertinent issues with great care. Primary emphasis will be placed on the following areas: Instrument Flight Simulator, energy conservation, rising fuel costs, budgetary constraints, training efficiency, and graduate quality.

I have enclosed a list of milestones proposed by my staff for your information. As we work the study, we will keep the Air Staff advised as to the current status and progress of the report.

We appreciate your personal interest and concern. I am confident that our efforts over the next several months will result in a viable alternative to the problem of the aging T-37.

Sincerely

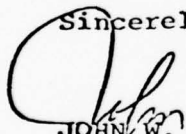
  
JOHN W. ROBERTS  
Lieutenant General, USAF  
Commander

1 Atch  
Milestones

112

APPENDIX B

PROGRAMMED IFS SYLLABI

The syllabi provided in this appendix are those which were used to project fleet insufficiency dates. They represent syllabi projected for use with the Instrument Flight Simulator (IFS).

UPT-IFS Syllabus

<u>Category</u>	<u>Normal Sortie Duration</u>	<u>Dual</u>	<u>Solo or Team</u>	<u>Total</u>
1. T-37 Phase				
a. Synthetic Trainer (T-4):				
Procedures/EPs(IP)	0.8	5/4.0		5/4.0
Basic (ITI*)	0.8	7/5.6		7/5.6
Instruments(ITI*)	0.8	12/9.6		13/11.2
	1.6	1/1.6		
Navigation(ITI*)	0.8	2/1.6		3/3.2
	1.6	1/1.6		
				<u>28/24.0</u>
b. Instrument Flight Simulator (T-50):				
Procedures	0.8		2/1.6(T)	2/1.6
Basic (IP)	0.8	7/5.6		10/10.4
	1.6	3/4.8		
Contact (IP)	0.8	1/0.8		1/0.8
Instruments (IP)	0.8	7/5.6		14/16.8
	1.6	7/11.2		
Navigation (IP)	0.8	1/0.8		4/5.6
	1.6	1/1.6	2/3.2(T)	
				<u>31/35.2</u>
c. Aircraft (T-37):				
Basic	1.3	2/2.6		2/2.6
Contact	1.3	27/34.8	8/9.8	35/44.6
Instruments	1.3	1/1.3		1/1.3
Navigation	1.5	6/9.0		6/9.0
Formation	1.3	9/11.7	2/2.6	<u>11/14.3</u>
				<u>55/71.8</u>
2. T-38 Phase				
a. Synthetic Trainer (T-7/T-26):				
Procedures/EPs(IP)	0.8	5/4.0		5/4.0
Basic (ITI*)	0.8	7/5.6		7/5.6
Instruments (ITI*)	0.8	11/8.8		16/16.8
	1.6	5/8.0		
Navigation (ITI*)	0.8	2/1.6		3/3.2
	1.6	1/1.6		
				<u>31/29.6</u>

UPT-IFS Syllabus (Cont'd)

<u>Category</u>	<u>Sortie Duration</u>	<u>Dual</u>	<u>Solo or Team</u>	<u>Total</u>
b. Instrument Flight Simulator (T-51):				
Procedures/EPs (IP)	0.8		2/1.6(T)	2/1.6
Basic (IP)	0.8	7/5/6		10/10.4
	1.6	3/4.8		
Contact (IP)	0.8	1/0.8		1/0.8
Instrument (IP)	0.8		15/12.0(T)	20/20.0
	1.6		5/8.0(T)	
Navigation (IP)	0.8	1/0.8		1/0.8
	1.6	1/16	2/3.2	3/4.8
				<u>37/38.4</u>
c. Aircraft (T-38):				
Basic	1.2	2/2.4		2/2.4
Contact	1.2	18/21.6	11/13.2	29/34.8
Instruments	---	---	--	---
Navigation	1.3	11/14.4	2/2.6	13/17.0
Formation	1.3	23/29.9	11/14.1	34/44.0
				<u>78/98.2</u>

\* May be taught by enlisted ITI or rated IP

IP -- Instructor Pilot

ITI -- Instrument Trainer Instructor

(T) -- Team

## SAPT IFS Syllabus (T-37 Only)

<u>Category</u>	<u>Normal Sortie Duration</u>	<u>Dual</u>	<u>Solo</u>	<u>Total</u>
a. Synthetic Trainer (T-4):				
Procedures/EPs (IP)	0.8	2/1.6		2/1.6
Instruments/ Navigation (ITI)	1.3	28/36.4		<u>28/36.4</u>
				30/38.0
b. Instrument Flight Simulator (T-50):				
Procedures/EPs (IP)	1.6	2/3.2		2/3.2
Contact (IP)	0.8	1/0.8		1/0.8
Instrument (IP)	0.8	11/8.8		26/32.8
	1.6	15/24.0		
Navigation (IP)	1.6	1/1.6		<u>1/1.6</u>
				30/38.4
c. Aircraft (T-37):				
Contact	1.3	53/68.2	11/13.6	64/81.8
Instrument	1.3	5/6.5		5/6.5
Navigation	1.5	11/16.3	1/1.4	12/17.7
Formation	1.3	22/28.6	2/2.6	<u>24/31.2</u>
				105/137.2

Other Programs

<u>Media</u>	<u>Normal Sortie Duration</u>	<u>Dual</u>	<u>Solo/ Team</u>	<u>Total</u>
1. T-37 PIT				
a. Trainer (T-4)	0.8	11/8.8		11/8.8
b. IFS (T-50)	0.8	4/3.2	4/3.2	19/24.0
	1.6	1/1.6	10/16.0	
c. Aircraft (T-37)	1.4	30/41.0	6/8.4	36/49.4
2. T-38 PIT				
a. Trainer (T-7/26)	0.8	10/8.0		10/8.0
b. IFS (T-51)	0.8	10/8.0	2/1.6	26/32.8
	1.6		14/22.4	
c. Aircraft (T-38)	1.2	19/22.8	8/9.6	45/55.8
	1.3	14/18.2	4/5.2	
3. IPIS				
a. Trainer (T-40)	2.0		2/4.0	2/4.0
b. Trainer (T-7/26)	2.0		2/4.0	2/4.0
c. IFS (T-51)	1.3	13/17.2		13/17.2
d. Aircraft (T-38)	1.3	10/13.0		10/13.0
4. Fixed Wing Qualification				
a. Trainer (T-4)		9/12.5		9/12.5
b. Aircraft (T-37)	1.3	33.5/43.2	1.5/1.8	35/45.0
c. Trainer (T-7/26)		20/27.5		20/27.5
d. Aircraft (T-38)	1.2	58/71.1	16/18.9	74/90.0

## APPENDIX C

### TRAINING REQUIREMENTS

This appendix provides expanded definitions of the training requirements identified for future Undergraduate Pilot Training. Originally defined during the FUPT Mission Analysis, some changes have occurred since that study. In particular, definitions have been expanded to include training peculiar to the Tanker-Transport-Bomber (TTB) leg of a specialized UPT system, where appropriate.

## TRAINING REQUIREMENTS

1. Ground Operations - Operations accomplished before takeoff and after landing that are necessary for flight and are accomplished prior to and following taxi operations, but to which flying time is not allocated. They consist of such events as preflight planning, completing forms, inspecting aircraft, and verifying flight readiness by actuating sub-systems.
2. Pre-Takeoff Taxi - Consists of moving the aircraft under its own power from the parking area to the takeoff run-up area preparatory to taking off. It begins with the application of power in the parking area and ends when the aircraft is lined up on the runway for takeoff.
3. Takeoff - Consists of the takeoff roll, rotation for lift off, and lift off. It begins with the lineup check and ends when the aircraft reaches climb airspeed and includes required corrections for crosswind effect.

### Takeoff - (TTB):

Rolling Takeoff - A single aircraft takeoff which begins on the taxiway with receipt of taxi clearance and ends with a stabilized climb attitude; aircraft does not stop on the runway for engine runup.

4. Formation Takeoff - Takeoff, where two or more aircraft are taking off simultaneously from a single runway maintaining a predetermined position and pattern in relation to one another. As in the normal takeoff, the formation takeoff begins with lineup check and is completed when aircraft reaches climb airspeed. It includes takeoff roll, rotation for lift off, and lift off.

Formation Takeoff - (TTB) includes:

Minimum Interval Takeoff - A takeoff by a succession of aircraft from a single runway with minimum time separation between them.

5. Climb/Level Off - Consists of climbing aircraft to a given altitude and configuring it for level flight at that altitude. It begins when the climb airspeed is reached and ends when altitude, airspeed, heading, and power settings are stabilized at the selected altitude. It includes post-takeoff actions such as configuring the aircraft for trimming for straight-and-level flight at the proper altitude.

6. Descent/Approach - Consists of descending the aircraft from its cruising or working altitude using either contact or instrument procedures, to either a landing or another cruising altitude. It begins when the preparation for descent is initiated and ends when the flare for landing is initiated or level off is effected at the new altitude. It

includes pre-descent configuration and the traffic pattern itself, or an approach and final approach. This includes low altitude instrument approaches. It also includes missed approaches and time spent in closed traffic.

7. Landing - Transitioning the aircraft from airborne flight to ground operations. It begins with the landing flare and ends at the end of the landing roll. It includes the flare, touch down and roll out, and required corrections for cross wind effects.

8. Post Landing Taxi - Consists of moving the aircraft under its own power and from one point to another on the airfield after completion of landing roll out. In general, only 5 minutes per sortie are allotted to taxi operations.

9. Basic Control - Maneuvers used for basic control of altitude, heading, airspeed, rate of climb/descent, and rate of turn. They begin when the first deviation in altitude, heading, airspeed, or rate of climb or descent is initiated for the purpose of training in this mode of flight. They end subsequent to the last deviation when the airspeed, altitude, are stabilized at desired cruise, climb or descent values. They consist of normal turns, descents, climbs, changes in heading, airspeed or altitude. This includes contact and instrument maneuvers.

10. Precision Control - Maneuvers practiced to develop precision coordination and rate changes in attitude, airspeed, heading and altitude. They begin when the area is visually cleared prior to entry in the first maneuver or upon deviation from a previous stabilized condition of flight and end when airspeed, heading and altitude are stabilized at the selected attitude following completion of the last maneuver. They consist of such maneuvers as the maximum performance climbing turn, "Lazy Eight," Vertical "S" maneuvers, steep turns, etc.

11. Departure Recognition and Recovery - Maneuvers practiced by the student for the purpose of recognizing the onset of departure from normal flight regimes, and the techniques and corrections needed for recovery therefrom. They begin when the student initiates airspace clearance procedures prior to initiation of the first maneuver and end when the airspeed, altitude, and heading are stabilized at the desired altitude upon completion. They consist of power on/off stalls, landing configuration stalls, spins (if applicable), spirals, etc. (This training requirement combines the previous requirements of Stall Recognition and Recovery and Spin Stall Recognition and Recovery.)

12. Aerobatics - Maneuvers in which the aircraft is maneuvered through all of its axes at varying airspeeds for the purpose of instilling confidence, and learning control techniques

for the aircraft in all airspeeds. They begin with the initiation of airspace clearance procedures prior to entering the first maneuver and are completed when the altitude, airspeed and headings are stabilized at the desired attitude following the final maneuver. They consist of Barrel Rolls, Aileron Rolls, Loops, Split "Ss," Immelmans, Cuban "8s," and Cloverleaves.

13. Unusual Attitude Recovery Maneuvers - Maneuvers which are utilized to regain attitude and airspeed control from unusual or vertical flight attitudes without stalling or overstressing the aircraft. They begin when the aircraft is placed in an unusual attitude by the instructor and are completed when the student has stabilized the aircraft in straight-and-level flight. They consist of instrument and contact high and low speed vertical, and spiral maneuvers.

14. Pilotage/Dead Reckoning Navigation - Navigation without radio aids. It consists of pilotage in which the aircraft is navigated from point to point by visual recognition of landmarks along the way, and dead reckoning in which a course and estimated time of arrival are computed, with visual recognition of the destination as the method of verification of arrival.

15. High/Low Altitude Navigation (Manual) - Navigation accomplished by means of manual operation of the aircraft in which position of the aircraft is determined by ground-based navigational aids and/or air/ground-based radar. Includes bearing pointer only procedures.

16. Close Formation - Flight where two or more aircraft are flown in close proximity to each other in a predetermined pattern and fixed position under the common direction of a single leader. In the case of UPT aircraft, separation will be on the order of 3 feet wingtip to wingtip. This training includes join up and rendezvous techniques, as well as position changes and interplane communications.

Close Formation - (TTB): To include "cell" formation flying.

17. Trail Formation - A type of formation in which station keeping at a distance to the rear of another aircraft is maintained through visual contact. This will include the position used during the inflight refueling.

18. Communications - Operation of on-board communications equipment to accomplish intra-plane, air base, enroute, and tactical communications.

19. Emergency Procedures Training - This training requirement encompasses contingency training for various

aircraft malfunctions. Procedures will be standardized as near as possible to those employed in similar situations in operational usage, except when specific training aircraft procedures dictate otherwise.

20. Tactical Formation - A type of formation in which the individual pilot within the formation maintains a fluid position on his element or flight lead which will permit him to visually scan 180 degrees of sky surrounding the lead aircraft, while maintaining separation such that he can maneuver with the lead aircraft as necessary.

21. Formation Landing - A landing performed simultaneously on a single runway by two aircraft while maintaining a fixed and predetermined position relative to each other. It begins at configuration for the landing and ends upon completion of the rollout.

22. Low Level Visual Navigation - Visual navigation accomplished at 1000 feet AGL or below. Consists of pilotage from point to point by visual recognition of landmarks, maintenance of enroute ETAs through airspeed adjustment and meeting a predetermined time-over-target.

23. Decision Making - The thinking processes that lead to the selection of one alternative from among a "known" set of response alternatives. These processes include the identification of the potential alternatives prioritizing the alternatives, and the selection of the desired alternatives. The

selection process may include computational and other logical operations for combining information.

24. Basic Fighter Maneuvers - Maneuvers used by a fighter pilot to position himself for the "kill" of an airborne target when his main reference is optical. This phase of the attack begins with the first visual sighting and positioning action and ends at the completion of the target tracking phase. It includes one-on-one combat as well as two-on-one and employs a variety of information techniques in the two-on-one mode. This training will include principles of energy maneuverability.

25. Air to Ground Fundamentals - The simulated delivery of unguided air-to-ground weapons. It begins upon entry into the bombing/gunnery pattern and ends upon recovery from the last pass. This training includes both high and low angle deliveries. The primary purpose is to teach the geometry of air-to-ground delivery maneuvers.

26. Air Drop Fundamentals - Consists of aligning the aircraft with a pre-designated track from an IP to a designated target area and flying it along the track taking into account wind effect. The simulated drop is effected by the crew member acting as drop master or bombardier. Drops may be made visually or electronically. This training requirement satisfies the basic elements of navigation and crew coordination

which are common between cargo and personnel drops and radar level bombing.

27. Radar Navigation - The theory and use of on-board airborne radar for weather avoidance and ground map navigation.

28. Crew Coordination - Interaction between crew members within the aircraft to accomplish required tasks.

29. Collision Avoidance - The theory and practice of avoiding mid-air collision through visual search techniques understanding of Air Traffic Control procedures and recognition of traffic congestion points in local traffic.

30. Airborne Rendezvous - Consists of establishing visual contact between two or more aircraft (or elements) at a predetermined time and location. It begins with separate takeoffs (not formation), alternate routes (or missions) to the rendezvous point and ends with visual contact and positioning of the two aircraft (elements).

APPENDIX D

MISSION PROFILES

The mission profiles depicted in this appendix were used to size conceptual aircraft designs. They serve as a useful point of departure for future mission profile development. A complete set of profiles for the XT-3 was not developed since, as a result of development of XT-1 and XT-2 concepts, the IFR navigation mission was determined as the sizing mission.

1. T-37 REPLACEMENT AIRCRAFT - SAMPLE CONTACT PATTERN MISSION

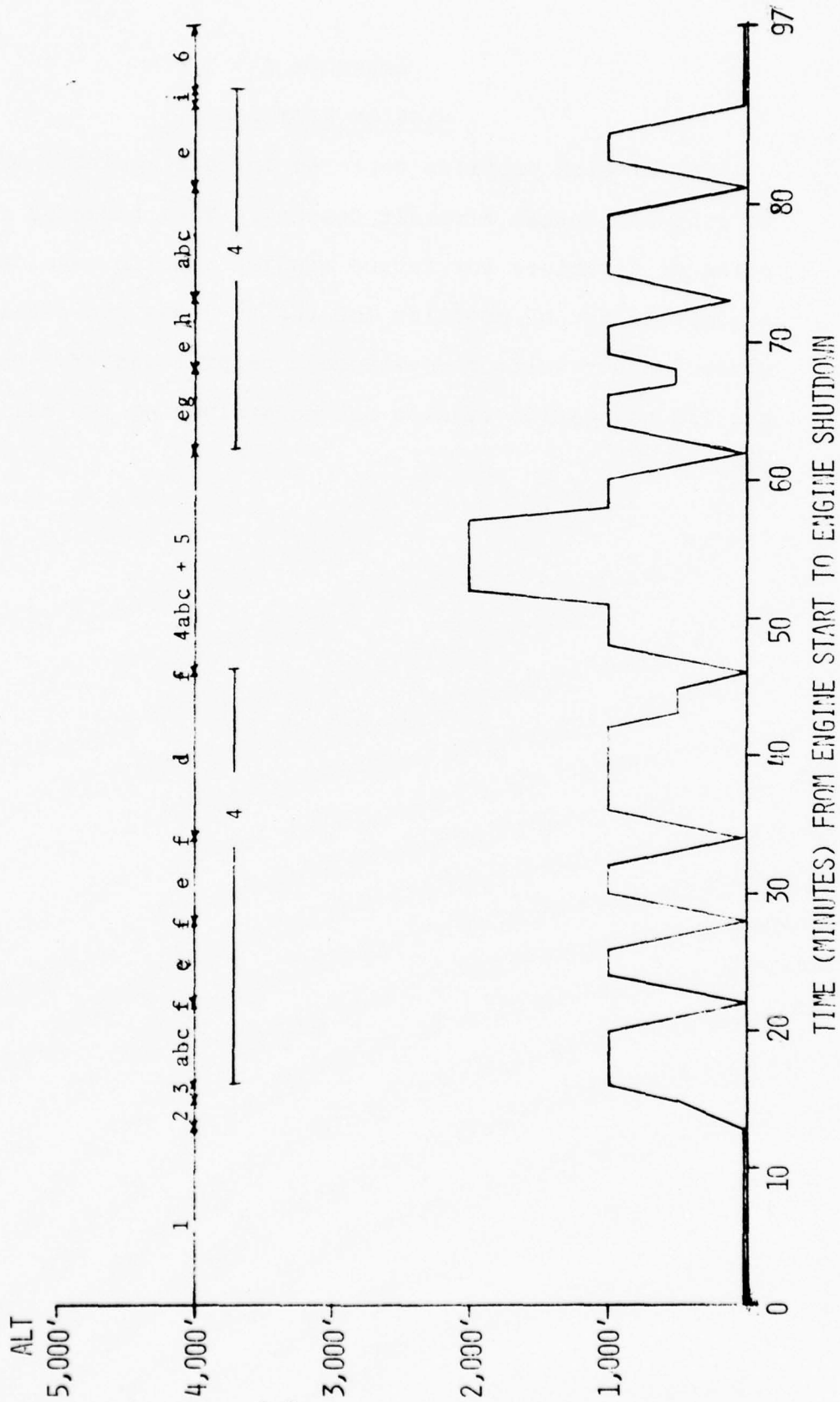

THIS PAGE INTENTIONALLY LEFT BLANK

1A. T-37 REPLACEMENT AIRCRAFT - SAMPLE CONTACT PATTERN MISSION

General Description: This is one of two contact mission extremes encountered in the primary phase of UPT. Mission consists of a climb to the home field traffic pattern followed by multiple VFR patterns and landings. An option to the home field pattern only mission would consist of a climb to a locally designated altitude, follow designated route to an auxiliary airbase, multiple VFR patterns and landings at the auxiliary field, and a return to the home field for final patterns and landings. This option will not be discussed.

	<u>Time and/or Distance</u>	<u>Altitude</u>	<u>Power Settings</u>
1. Start, taxi	12-15 min	0' AGL	Idle to taxi pwr
2. Takeoff	2 min	0 - 500' AGL	Mil pwr
3. Level-off	1 min	1000' AGL	Pwr to hold 200 KIAS
4. VFR traffic patterns and landings	6 min	1000' to 0' AGL	Pwr to hold 200 IAS to idle
a. Normal overhead traffic pattern			Mil to idle
b. Single engine overhead pattern	6 min	1000' to 0' AGL	Mil to idle
c. No flap overhead pattern	6 min	1000' to 0' AGL	Mil to idle
d. Straight-in approach (normal and no-flap)	10 min	1000' to 0' AGL	Mil to idle
e. Closed traffic pattern	4 min	1000' to 0' AGL	Mil to idle
f. Touch and go landing	Less than 1 min	0' - 500' AGL	Idle to mil pwr
g. Low approach	1 min	1000' to 500' AGL	Mil to reduced pwr
h. Go-around	1 min	1' - 500' AGL	Idle to mil pwr
i. Full stop landing	Less than 1 min	0' AGL	Idle
5. Breakout and pattern re-entry	5-10 min	1000' to 2000' AGL	Mil to pwr to hold 200 KIAS
6. Taxi/engine shutdown	10 min		
7. Reserve	20 min	10,000' MSL	Max endurance

1b. Maneuver Description - Traffic Pattern Contact Mission

1. Start, Taxi - Consists of starting engines, completing before takeoff, ground checks, request and receipt of clearance, and taxi to the active runway.

2. Takeoff - Consists of positioning aircraft on the runway, performing engine run-up checks, takeoff roll, lift-off, configuring aircraft for climb, and climbing to an altitude and airspeed where climb can begin.

3. Level-off - Consists of leveling the aircraft at a desired altitude and accelerating to a desired airspeed. Power must be set for desired cruise airspeed.

4. VFR Traffic Patterns and Landings - Typical pattern mission consists of a variety of normal, single-engine, and no-flap overhead patterns flown to a touch-and-go landing. Most missions of this type are pre-solo student sorties, hence go-arounds (instructor or student initiated) or low approaches (runway supervisory unit directed) are often required. Normally a maximum of two straight-in approaches will be accomplished. Since the most critical areas for student training are the final turn, final approach, and landings, closed traffic patterns are used to allow a greater number of repetitions of the critical areas. The mission concludes with a full-stop landing.

5. Breakout and Pattern Re-entry - Occasionally, due to traffic conflict, breakout of the pattern is required. A mil pwr climb to a locally designated altitude is made. The aircraft then proceeds to a locally designated entry point where an idle power descent is made and the pattern re-entered.

6. Taxi/Engine Shutdown - Begins when the aircraft clears the runway and ends when the engines are shut down. Requires completion of an after landing check, taxi to the parking area, and completion of engine shutdown check.

7. Reserve - Amount of fuel remaining for safety reasons, should any emergency/malfunction or other factor prevent landing at the home field when desired.

2. T-37 REPLACEMENT AIRCRAFT - SAMPLE ADVANCED CONTACT MISSION

This mission profile is included in the text as Figure 13 and Tables 11 and 12.

3. T-37 REPLACEMENT AIRCRAFT - SAMPLE BASIC MISSION

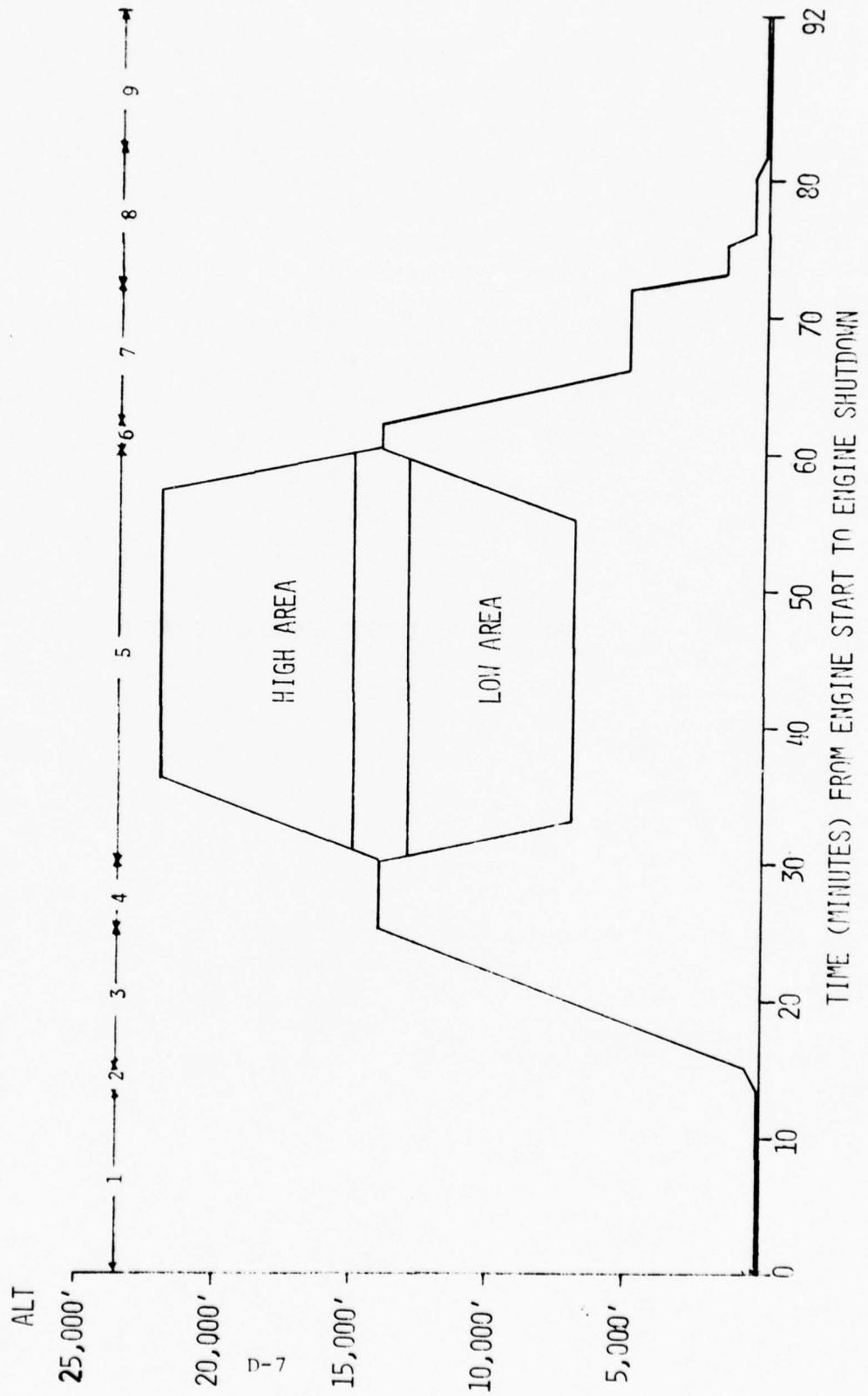

THIS PAGE INTENTIONALLY LEFT BLANK

3A. T-37 REPLACEMENT AIRCRAFT - SAMPLE BASIC MISSION

General Description: Basic category missions teach student pilots basic flying skills which are prerequisites to learning more advanced maneuvers in the contact and instrument categories. Consists of a departure to a local flying area, basic maneuvers performed in that area, and return to the home field for landing.

	<u>Time and/or Distance</u>	<u>Altitude</u>	<u>Power Settings</u>
1. Start, taxi	12-15 min	0' AGL	Idle to taxi pwr
2. Takeoff	2 min	500' AGL	Mil pwr
3. Climb/level-off	10 min	13-15,000' MSL	Mil pwr
4. Area entry	5 min	13-15,000' MSL	Best cruise
5. Area work	30 min	7-13,000' MSL	Idle to mil
5. a. Climbs and descents (rate and constant airspeed)	max distance from home field = 60 miles	or 15-22,000' MSL	Best cruise
5. b. Turns (normal, medium, steep)			
5. c. Airspeed changes			
5. d. Straight and level			
6. Area exit	2 min	13-15,000' MSL	Idle or mil
7. Return to base	10 min	5000' MSL	Best cruise
8. Traffic pattern	10 min	1000' - 0' AGL	Best cruise to idle
8. a. Straight-in approach			
8. b. Full stop landing			
9. Taxi, engine shutdown	10 min	0' AGL	Idle to taxi pwr
10. Reserve	20 min	10,000' MSL	Max endurance

3B. Maneuver Description - Sample Basic Mission

1. Start, Taxi - Previously explained/self-explanatory.
2. Takeoff - Previously explained/self-explanatory.
3. Climb/Level-off - Consists of climbing the aircraft at its best rate of climb to a desired altitude, leveling the aircraft at that altitude, and accelerating to a desired cruise airspeed. Power must be set from mil to cruise pwr.
4. Area Entry - Consists of flying the aircraft from the point of level off to the locally designated point where an assigned area can be entered.
5. Area Work - Begins with a change of power to enter the assigned area, and ends with a change of power to exit the assigned area. Includes performance of required maneuvers, and time to analyze, set up, and critique those maneuvers. Approximately 200 square miles of airspace are required for each area. Areas are usually stratified into high (15-22,000') and low (7-13,000') blocks for maximum utilization of airspace.
6. Area Exit - Consists of a descent to a locally designated altitude, and compliance with a locally designated return route. A climb may be necessary from a low area, but normal area exit entails an idle to reduced power letdown.
7. Return to Base - Consists of compliance with locally designated return routes to arrive at a point where the home field traffic pattern is entered.
8. Traffic Pattern - Previously explained/self-explanatory.
9. Taxi, Engine Shutdown - Previously explained/self-explanatory.
10. Reserve - Previously explained/self-explanatory.

4. T-37 REPLACEMENT AIRCRAFT - SAMPLE INSTRUMENT MISSION

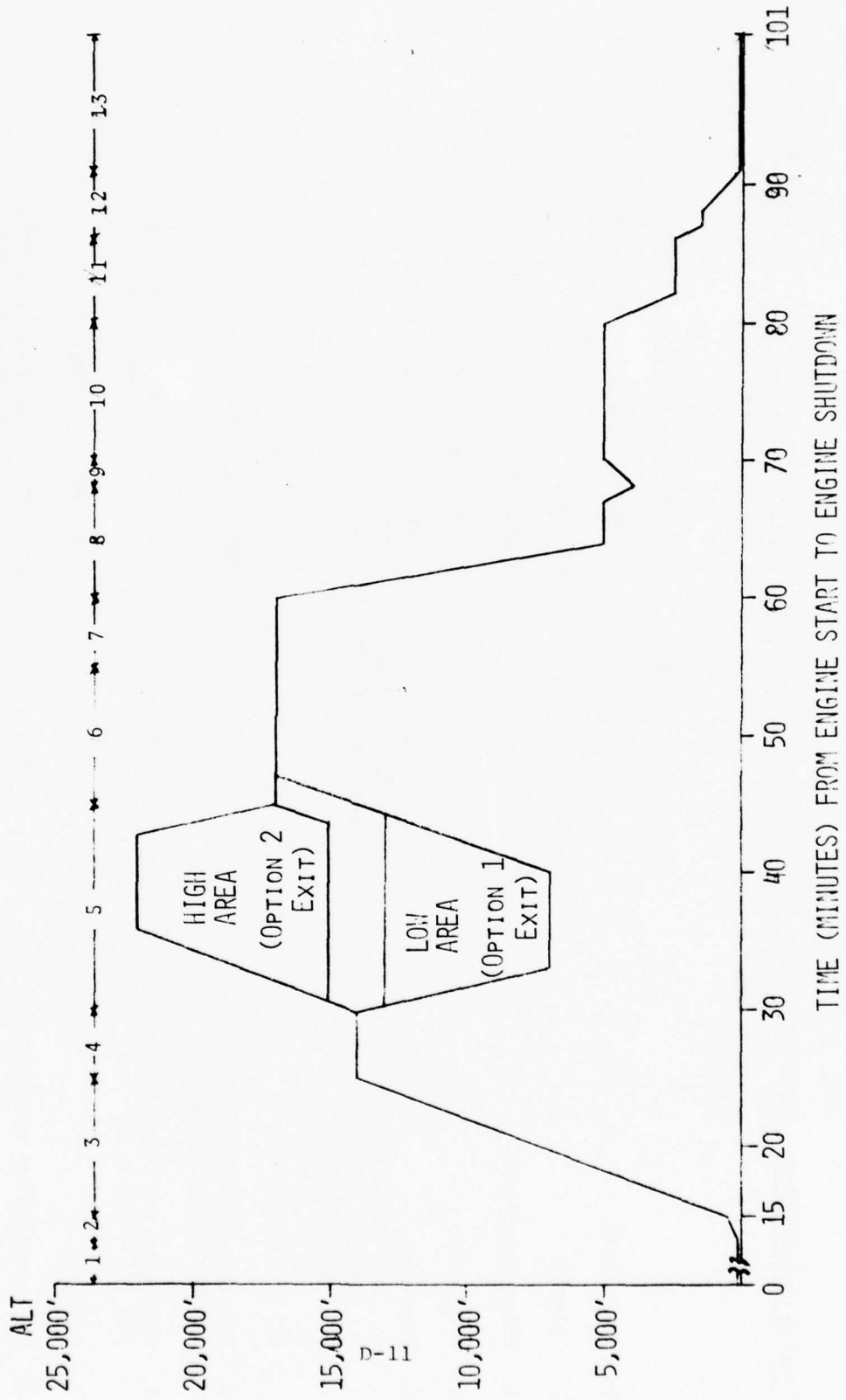

4A. T-37 REPLACEMENT AIRCRAFT - SAMPLE INSTRUMENT MISSION

General Description - Mission profile generally consists of the following: takeoff, climb to local area for instrument maneuvers work; VOR holding pattern practice; VOR penetration, approach, and missed approach; and precision approach (PAR or ILS) to a full stop landing.

	<u>Time and/or Distance</u>	<u>Altitude</u>	<u>Power Settings</u>
1. Start/taxi	12-15 min	0' AGL	Idle to taxi power
2. Takeoff	2 min	500' AGL	Mil
3. Climb/level-off	10 min	13-15,000' MSL	Mil power
4. Area entry	5 min	13-15,000' MSL	Best cruise
5. Area work	15 min/ Max distance from home field = 60 mi	7-13,000' MSL or 15-22,000' MSL	Idle to mil
a. Confidence maneuvers			
b. Unusual attitudes			
c. Point-to-point			
d. Course maneuvers			
e. Arc maneuvers			
6. Low area exit/climb to VOR IAF altitude (Option 1)	10 min	17,000' MSL	Best cruise to mil
6. High area exit/cruise to VOR IAF (Option 2)	10 min	17,000' MSL	Best cruise to mil/ reduced power
7. Holding	5 min	17,000' MSL	Best cruise
8. VOR penetration and approach	8 min	4,000' MSL	Reduced to landing Configuration power
9. Missed approach/climb	2 min	5,000' MSL	Mil
10. Cruise to home field	10 min	5,000' MSL	Best cruise

	<u>Time and/or Distance</u>	<u>Altitude</u>	<u>Power Settings</u>
11. GCA Pattern	6 min	2500' AGL	Low cruise
12. PAR or ILS approach and landing	5 min/10 mi	1500' AGL	Landing configuration power to idle
13. Taxi/engine shutdown	10 min	0' AGL	Idle to taxi power
14. Reserve	20 min	10,000' MSL	Max endurance

4B. Maneuver Description - Instrument Mission

1. Start/Taxi - previously explained/self-explanatory.
2. Takeoff - previously explained/self-explanatory.
3. Climb/Level-off - previously explained/self-explanatory.
4. Area Entry - previously explained/self-explanatory.
5. Area Work - Consists of the following maneuvers, performed in any sequence: Confidence maneuvers (wingover, aileron roll), unusual attitudes (climb and dive recoveries, upright and inverted), point-to-point, course interception and course maintaining, arc interception and maintaining arc. Area size should be 200 sq miles.
6. Area Exit - Option 1: Exit assigned low area and climb to locally designated altitude. Proceed at best cruise to VOR Initial Approach Fix (IAF).  
Option 2: Exit assigned high area at VOR IAF altitude and cruise to VOR IAF.
7. Holding - Student pilots are normally required to perform this maneuver on every ride requiring a VOR penetration and approach. Time permitting, students may be required to fly more than one holding pattern, adjusting speed to meet a known expected approach clearance time (EAC). If a crew is established in holding, subsequent crews will be assigned higher holding altitudes (1,000' increments). Two possible holding options that will not be discussed are: holding in assigned area, and holding over a VOR other than the home field VOR.
8. VOR Penetration and Approach - generally starts with a reduced power descent from the IAF, usually with extended speed bakes. Generally requires that the aircraft fly out-bound from the VOR for at least half of the desired altitude to be lost, then turning inbound to the VOR while descending to the required altitude. Aircraft must be partially configured for landing (normally gear and landing lights) prior to descending to minimum approach altitude. The flaps and speed brake are not normally lowered due to the approach being concluded with a missed approach rather than a landing. The option of flying a VOR penetration and approach at other than the home field will not be discussed.

9. Missed Approach/Climb - maneuver which is designed to get an aircraft to a safe altitude and area to start a second weather approach for landing or a divert to an alternate airfield. In UPT, this maneuver is flown on most instrument missions to improve student proficiency. Consists of a mild power climb, retracting landing gear and lights, reduced power climb (once desired climb airspeed has been reached), and a level-off at an airspeed that facilitates beginning the next approach (or cruise, in the case of a divert).

10. Cruise to Home Field - used if VOR penetration and approach is flown at other than the home field. Normally use best cruise.

11. GCA Pattern - consists of either a rectangular or straight-in series of vectors, directed by approach control personnel, using surveillance radar. Purpose of the approach is to get the aircraft sequenced with other landing traffic and turned on to a precision final approach approx 10 miles prior to touchdown. Generally, one or two descents are required and initial landing configuration is attained prior to final approach (landing gear and flaps). Power is used as necessary to hold landing configuration airspeed.

12. PAR or ILS Approach and Landing - consists of getting the aircraft on the ground from an approximate 10 mile final by either precision approach radar (PAR - flown by the pilot, directed by a ground based final controller) or by Instrument Landing System (ILS - flown by the pilot, directed by instrumentation). At most UPT bases, these approaches are flown to a full stop landing. Final configuration for landing (landing lights and speed brakes) is usually made on final or when final descent for landing begins. Continual, small power changes are required to maintain final approach airspeed and rate of descent.

13. Taxi/Engine Shutdown - previously explained/self-explanatory.

14. Reserve - previously explained/self-explanatory.

5. T-37 REPLACEMENT AIRCRAFT - SAMPLE LOW-LEVEL VFR NAVIGATION MISSION

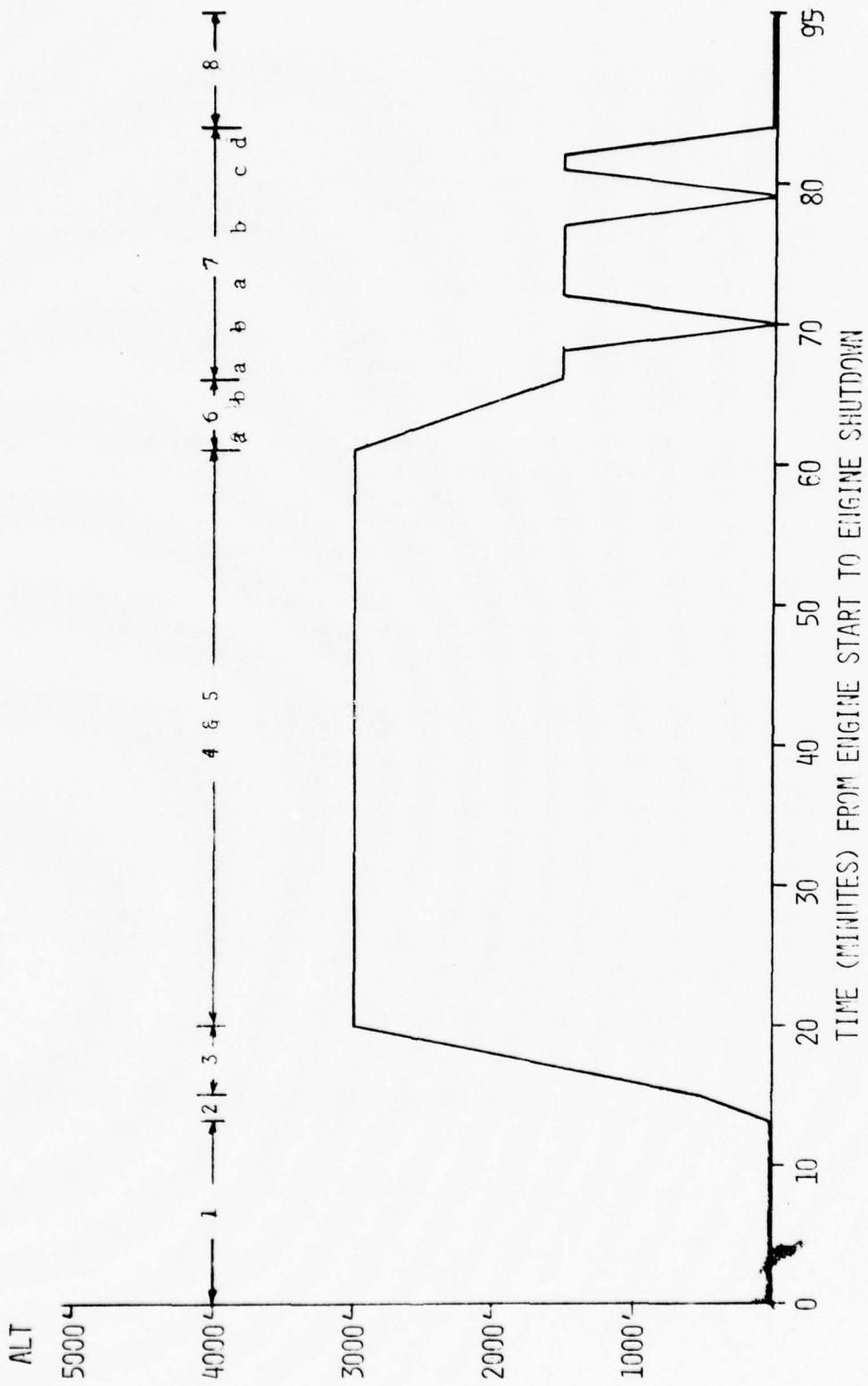

5A. T-37 REPLACEMENT AIRCRAFT - LOW LEVEL VFR NAVIGATION

General Description: This is one of 2 typical navigation mission profiles that could be encountered in the primary phase of UPT. Mission consists of departure from home base, climb to cruise altitude, navigation practice along a predetermined route of flight, and VFR pattern work at the destination base.

<u>Task/Maneuver</u>	<u>Time and/or Distance</u>	<u>Altitude</u>	<u>Power Settings</u>
1. Start, Taxi	12-15 min	Ground level	Idle to taxi power
2. Takeoff	2 min	200-500' AGL	Mil Power
3. Departure/climb	2 min (5 mi)	3000' AGL	Mil Power
4. Level-off	1 min	3000' AGL	Mil to Cruise Power
5. Navigate (VFR)	40 min (approx 200 mi)	3000' AGL	Cruise Power
6. Destination Arrival	5 min (15 mi)	1500' AGL	Cruise to Idle to Traffic Pattern Power Setting
a. Descent			
b. Pattern entry			
7. Traffic Patterns	10-15 min	1500' AGL to ground level	Traffic Pattern Power Setting to Idle to Mil Power
a. Overhead pattern			
b. Touch-and-go (2, including go-arounds)			
c. Closed pattern			
d. Full stop			
8. Taxi, engine shutdown	10 min	Ground level	Taxi Power to Idle
9. Fuel Reserve	20 min	10,000' MSL	Max endurance

5B. Maneuver Description - Low Level VFR Navigation

1. Start, Taxi - previously explained/self explanatory.
2. Takeoff - previously explained/self explanatory.
3. Departure/Climb - climb from attainment of climb airspeed to a predetermined altitude over a predetermined ground track.
4. Level-off - requires an acceleration to a predetermined indicated airspeed based upon a desired ground speed.
5. Navigate (VFR) - student is required to fly a preplanned route using visual references and an area map. Normally, aircraft will not deviate from planned ground track. Power changes only required to adjust ground speed to make planned times over several check points.
6. Destination Arrival - includes a descent to traffic pattern altitude, determining correct runway for landing, and maneuvering the aircraft to an initial. Changes in airspeed from cruise to descent, to traffic pattern speed are required with corresponding power changes.
7. Traffic Patterns - no change from previous VFR traffic patterns with the exception of 1500' pattern altitude vs the 1000' pattern at the home base.
8. Taxi, Engine Shutdown - previously explained/self explanatory.
9. Fuel Reserve - required by AFR 60-16 should weather/emergency prevent or delay landing at destination base.

6. T-37 REPLACEMENT AIRCRAFT - SAMPLE IFR NAVIGATION MISSION

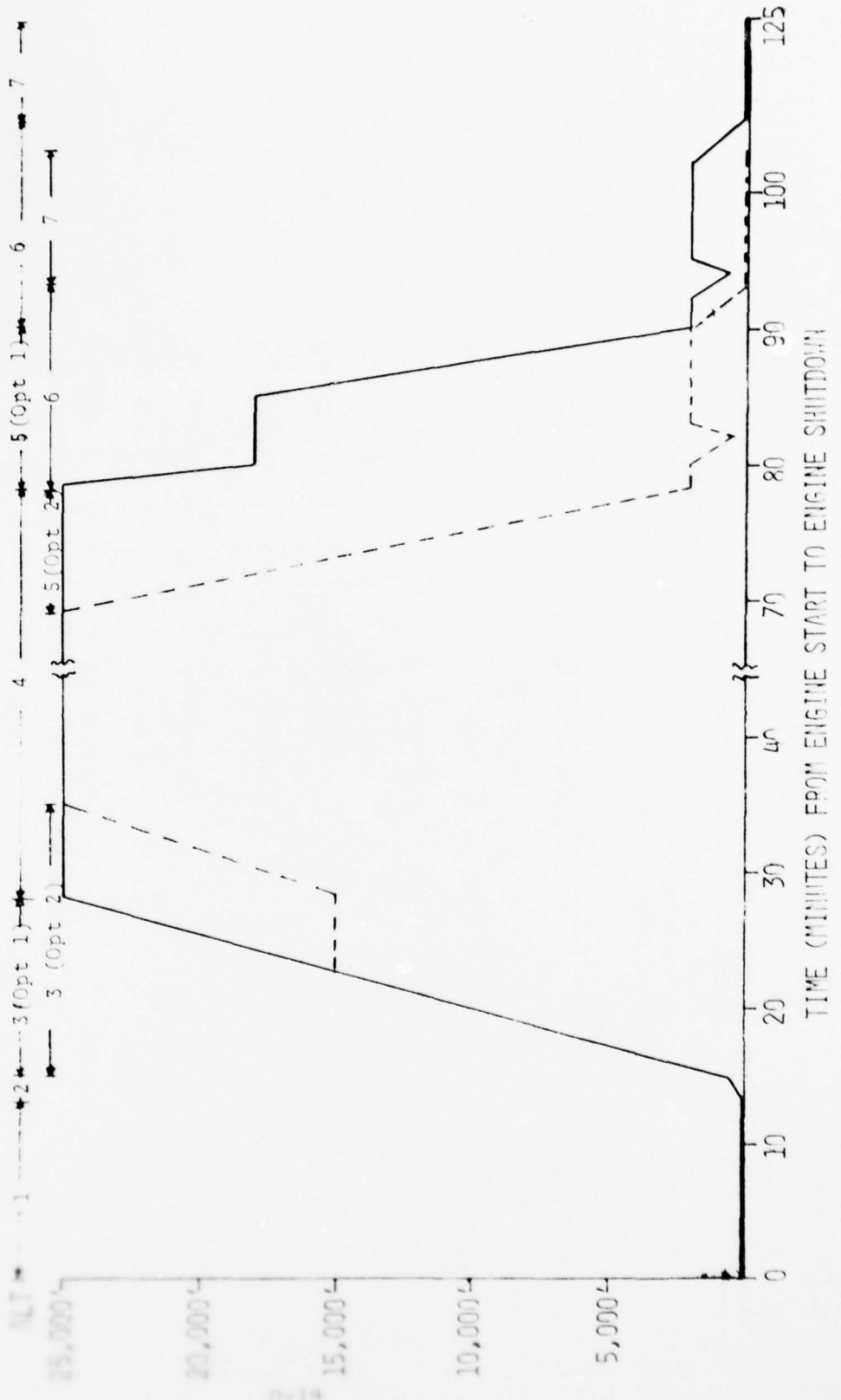

6A. T-37 REPLACEMENT AIRCRAFT - IFR NAVIGATION

**General Description:** This is the second of two typical navigation profiles that could be encountered in the primary phase of UPT. Mission consists of departure from home or strange base, climb to cruise altitude, navigation along a pre-planned route of flight using IFR procedures, descent to destination base, and IFR pattern work at the destination base.

<u>Task/Maneuver</u>	<u>Time and/or Distance</u>	<u>Altitude</u>	<u>Power Settings</u>
1. Start, Taxi	12-15 min	0' AGL	Idle to taxi power
2. Takeoff	2 min	200-500' AGL	Mil power
3. Climb, Option 1 Climb, Option 2	13 min/45 mi	25,000' MSL	Mil power
a. Climb	6 min/21 mi	15,000' MSL	Mil power
b. Intermediate level-off	1-10 min/4-40 mi	15,000' MSL	Best cruise
c. Climb	7 min/	25,000' MSL	Mil power
4. Navigate (IFR)	50 min/250 mi	25,000' MSL	Best cruise
5. Descent, Option 1	2 min/10 mi	18,000' MSL	Idle
a. Descent	5 min	18,000' MSL	Max endurance (MIN)
b. Holding (optional)	5 min	2,000' AGL	Idle
c. Penetration			
Descent, Option 2	9 min/37 mi	2,000' AGL	Idle to reduced power
a. Enroute Descent			
6. IFR Traffic Patterns			
a. Non-precision approach	4 min	2,000 - 400' AGL	Landing
b. Precision approach	10 min	2,000 - 100' AGL	Configuration power
c. Landing	Included above	0' AGL	Landing Configuration power Idle
7. Taxi, shutdown	10 min	0' AGL	Idle to taxi power
8. Reserve	20 min	10,000' MSL	Max endurance

6B. Maneuver Description - IFR Navigation

1. Start, Taxi - previously explained/self explanatory.
2. Takeoff - previously explained/self explanatory.
3. Climb (option 1) - mil power climb by either standard instrument departure (SID) or radar monitored departure to first fix on a preplanned and air traffic controlled, approved IFR route. Altitude of 25,000 estimated to be the maximum needed in a T-37 replacement aircraft (unpressurized maximum altitude, reference AFR 60-16). The option includes a level-off and acceleration to a planned cruise airspeed.

Climb (option 2) - same as above, except that an intermediate level off may be required by either a SID or by Air Traffic Control prior to reaching cruise altitude.

4. Navigate (IFR) - student is required to fly a pre-planned IFR route. Deviations from planned route, altitude, or airspeed are not allowed except in the case of an emergency/malfunction or an Air Traffic Control request.

5. Descent (option 1) - includes a descent to either holding altitude or initial approach fix altitude prior to starting a penetration to an altitude and position from which an instrument approach may be flown to the destination base.

Descent (option 2) - includes an en route descent to an altitude and position from which an instrument approach may be flown to the destination base. Primary purpose of the en route descent is to save time and to conserve fuel.

6. IFR Traffic Patterns - normally, two approaches - one non-precision (VOR, VORTAC, ASR) and one precision (PAR, ILS) - are flown prior to landing. The first approach is flown to minimums at which point a mil power missed approach (climb) is started and the aircraft positioned by approach control or navigational aids for a second approach. The aircraft normally lands out of the second approach.

7. Taxi, Shutdown - previously explained/self explanatory.
8. Reserve - previously explained/self explanatory.

7. T-37 REPLACEMENT AIRCRAFT - SAMPLE FORMATION MISSION

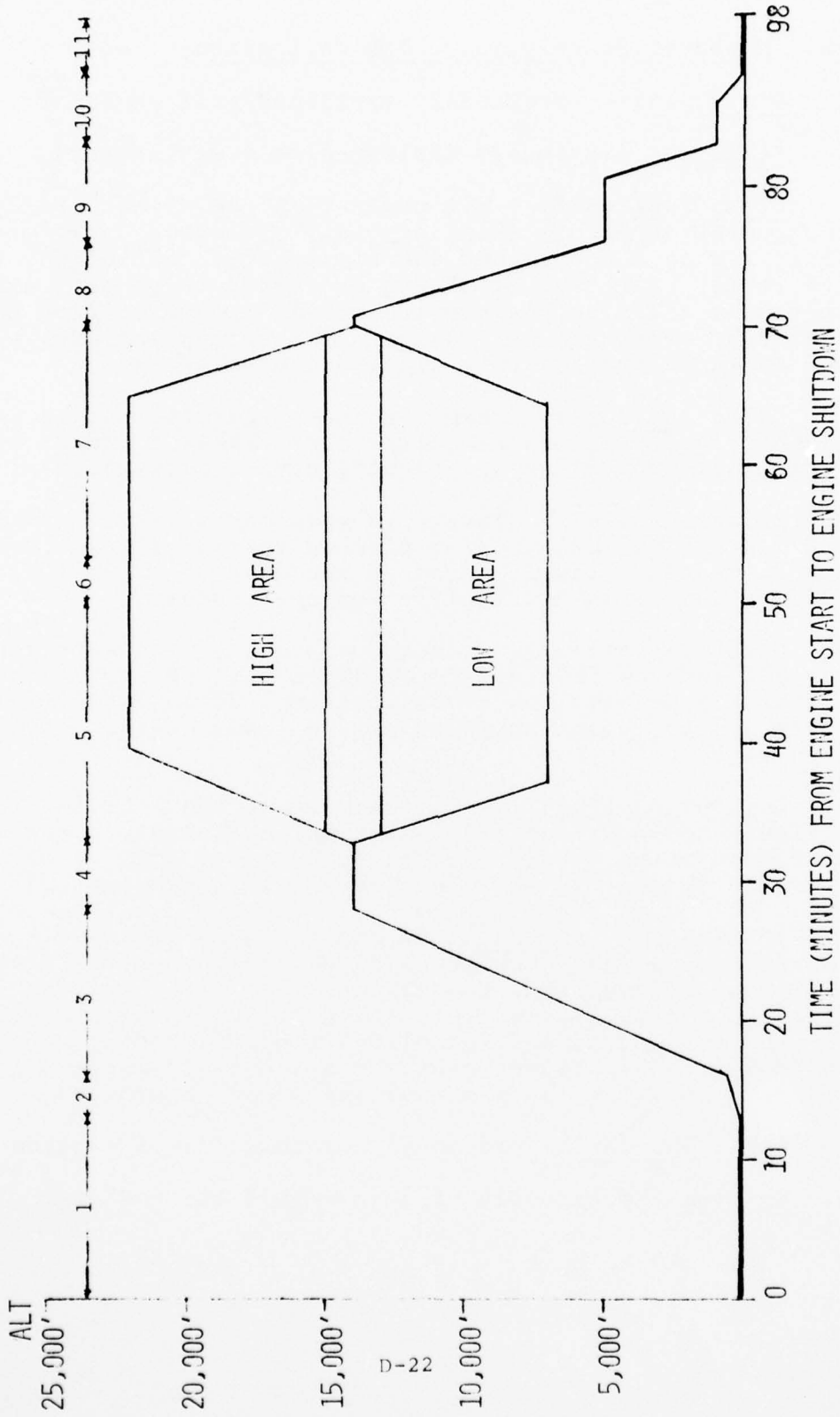

7A. T-37 REPLACEMENT AIRCRAFT - SAMPLE FORMATION MISSION

General Description - In the primary phase of UPT, consists of two aircraft taking off together, proceeding to a local area for formation maneuvers, exchanging positions to allow equal practice of lead and wing positions, continuation of formation maneuvers, descent and return to home field for formation overhead pattern or straight-in landing (instrument or contact)

	<u>Time and/or Distance</u>	<u>Altitude</u>	<u>Power Settings</u>
1. Start/taxi	12-15 min	0' AGL	Lead: idle to taxi power Wing: idle to taxi power
2. Takeoff	3 min	500' AGL	Lead: 98% power Wing: As required
3. Climb	12 min	13-15,000' MSL	Lead: 98% power Wing: As required
4. Cruise to area	5 min	13-15,000' MSL	Lead: Normal cruise Wing: As required
a. Crossunders			
b. Route position			
5. Area work	15-20 min/ max distance from home field = 60 mi	15-22,000' MSL or 7-13,000' MSL	Lead: Normal cruise to best cruise Wing: Idle to mil
a. Rejoins			
b. Finger tip maneuvers			
c. Trail			
6. Position change	3 min	15-22,000' MSL or 7-13,000' MSL	Lead: Normal cruise to reduced power Wing: As required to normal cruise
7. Area work (Maneuvers are the same as in 5 above)	15-20 min	15-22,000' MSL or 7-13,000' MSL	Lead: Normal cruise to best cruise Wing: Idle to mil

	<u>Time and/or Distance</u>	<u>Altitude</u>	<u>Power Settings</u>
8. Area exit/descent			
a. Crossunders	6 min	5,000' MSL	Lead: Reduced power (200 KIAS w/speed brake)
b. Route position			Wing: As required (200 KIAS w/speed brake)
9. Pattern entry			
a. Echelon turns	7 min	1,000' AGL	Lead: Normal cruise (descent w/speed brake)
			Wing: As required (descent w/speed brake)
10. Traffic pattern and landing			
	5 min	1,000' to 0' AGL	Lead: Normal cruise to idle
			Wing: As required to idle
11. Taxi/engine shutdown			
	10 min	0' AGL	Lead: Idle to taxi power
			Wing: Idle to taxi power
12. Reserve			
	20 min	10,000' MSL	Max endurance

7B. Maneuver Description - Formation Mission

1. Start/Taxi - previously explained/self-explanatory.
2. Takeoff - requires slightly more time than single-ship takeoff due to lead aircraft using slightly less than mil power. This reduced power allows the wingman a catchup capability in the event he falls behind.
3. Climb - requires slightly more time than single-ship climb due to lead aircraft using slightly less than mil power. Wingman uses power as required to remain in position.
4. Cruise to Area - Lead uses normal cruise power setting, wingman uses power as required to stay in fingertip (3' wingtip clearance) position. Crossunders and route position normally occur during this portion of the flight. Crossunders require the wingman to change power slightly more than that required to stay in fingertip. Route position, used for performing checks is a widened formation. Wingman must vary power slightly to move out to and in from route position.
5. Area Work - Fingertip maneuvers require that the leader take the formation through a wide range of airspeeds, pitch, and bank to allow the wingman to build up proficiency in maintaining proper position. Power changes by a wingman with a low level of proficiency could conceivably range from idle to mil, while those of a highly proficient wingman might not vary from lead's set power by more than  $\pm 5\%$ . Rejoins are used to practice reforming a formation once it has separated. Generally requires that lead and wing separate by delaying pitchouts ( $60^\circ$  bank,  $180^\circ$  turn). Lead then either maintains straight and level at a pre-briefed airspeed, or a level, shallow-banked turn at a pre-briefed airspeed (pre-briefed airspeed generally close to normal cruise). The wingman must rejoin to a fingertip position by varying bank, power, and pitch as necessary. Trail formation requires that a wingman "follow the leader" from a position that is similar to the refueling position used by fighter aircraft (nose-tail). Once the leader ascertains that his wingman is in position, he takes the formation through a series of varied pitch and bank maneuvers to build up the wingman's proficiency. The wingman must use pitch, bank, and power as necessary to stay in position.

6. Position Change - requires that the formation spread apart and a position change be directed by the leader. When the wingman is ready to assume lead duties, he informs the leader, who slides back to a wing position. The formation is directed to close position and continues with area maneuvers under the direction of the new leader. Power changes are very minimal. The change is normally made from a straight-and-level position.
7. Area Work - previously explained/self-explanatory.
8. Area Exit/Descent - consists of a reduced power descent. Speed brakes may be used to increase rate of descent. Cross-under exercises are normally accomplished, and route position is used for required checks. Although not discussed in this profile, a formation may proceed to a local VOR for formation instrument approach practice.
9. Pattern Entry - the wingman must be positioned on the side of lead opposite the direction of the traffic pattern. Low altitude turns are usually echelon turns (wingman remains level with lead, matches his bank and uses power to maintain position).
10. Traffic Pattern and Landing - the formation separates at the pitch point, by wing delaying the pitchout after the leader. Each aircraft flies its own pattern and landing, except that lead flies a slightly tighter pattern than normal and the wingman may loosen his pattern slightly to gain proper spacing.
11. Taxi/Engine Shutdown - both aircraft taxi as a formation.
12. Reserve - previously explained/self-explanatory.

1. SINGLE AIRCRAFT UPT - SAMPLE TRAFFIC PATTERN CONTACT MISSION

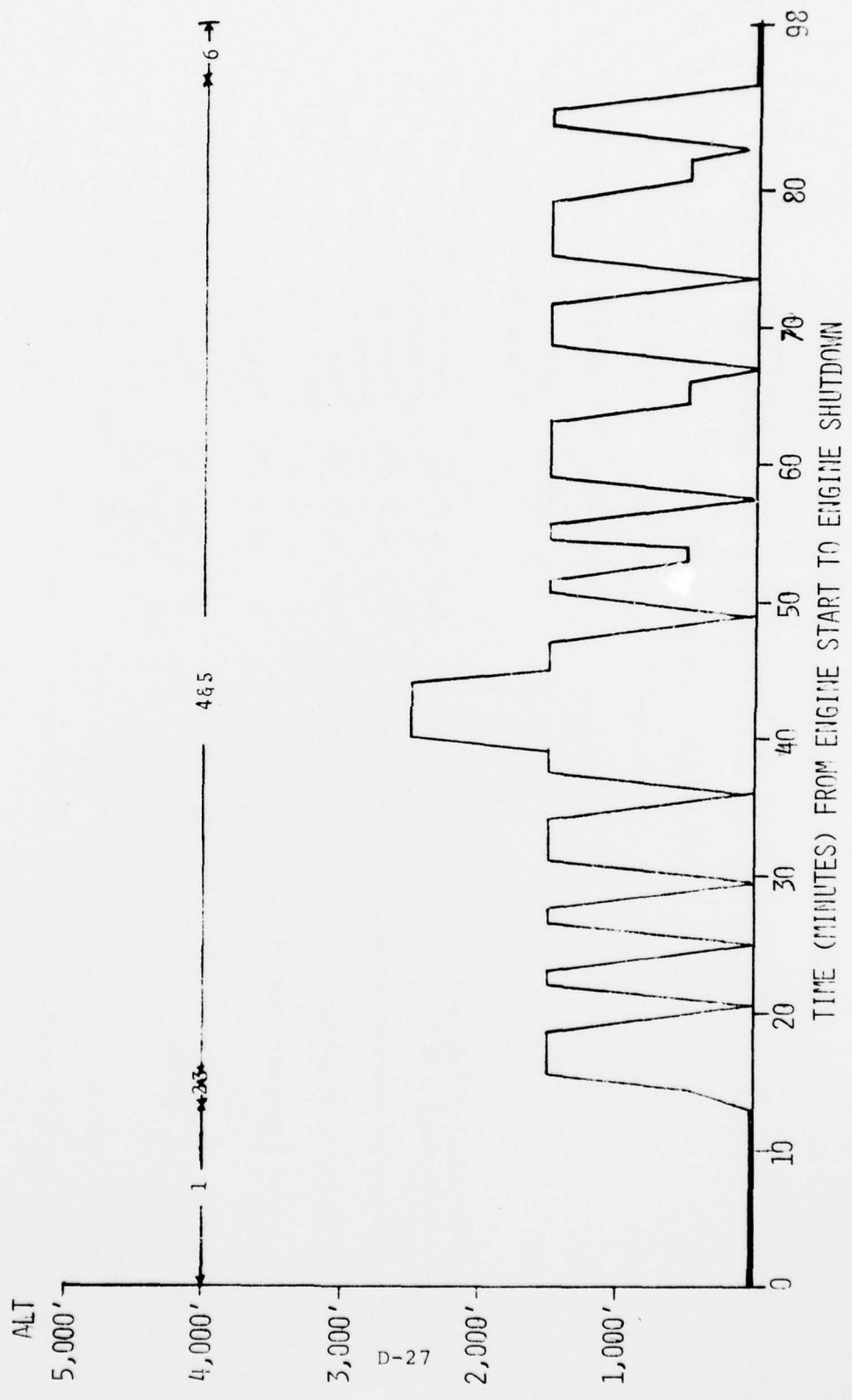

1A. SINGLE AIRCRAFT UPT - SAMPLE TRAFFIC PATTERN CONTACT MISSION

General Description: This is one of two contact mission extremes. Mission consists of a climb to the home field traffic pattern followed by multiple VFR patterns and landings.

	<u>Time and/or Distance</u>	<u>Altitude</u>	<u>Power Settings</u>
1. Start/taxi	12-15 min	0' AGL	Idle
2. Takeoff	1-1/2 min	0-500' AGL	Max power
3. Level-off	1 min	1500' AGL	Mil to power to hold 250 KIAS
4. VFR traffic patterns and landings			
a. Normal overhead traffic pattern	5 min	1500' to 0' AGL	Power to hold 250 KIAS to idle
b. Single engine overhead pattern	5 min	1500' to 0' AGL	Power to hold 250 KIAS to idle
c. No flap overhead pattern	5 min	1500' to 0' AGL	Power to hold 250 KIAS to idle
d. Straight-in approach (normal and no-flap)	8 min	1500' to 0' AGL	Power to hold 250 KIAS to idle
e. Closed traffic pattern	3 min	1500' to 0' AGL	Power to hold 250 KIAS to idle
f. Touch and go landing	Less than 1 min	0' to 500' AGL	Idle to mil
g. Low approach	1 min	1500' to 500' AGL	Idle to mil
h. Go-around	1 min	1' to 500' AGL	Idle to mil
i. Full-stop landing	Less than 1 min	0' AGL	Idle to mil/max Reduced power to idle
5. Breakout and pattern re-entry	4-8 min	2500' AGL	Mil to power to hold 250 KIAS
6. Taxi/engine shutdown	10 min	0' AGL	Idle
7. Reserve	20 min	10,000' MSL	Max endurance

1B. Maneuver Description - Traffic Pattern Contact Mission

1. Start/Taxi - consists of starting engines, completing before takeoff, ground checks, request and receipt of clearance, and taxi to the active runway.
2. Takeoff - consists of positioning the aircraft on the runway, performing engine run-up checks, takeoff roll, lift-off, configuring aircraft for climb, and climbing to an altitude and airspeed where climb can begin.
3. Level-off - consists of leveling the aircraft at a desired altitude and accelerating to a desired airspeed. Power must be set for desired cruise airspeed.
4. VFR Traffic Patterns and Landings - typical pattern mission consists of a variety of normal, single-engine and no-flap overhead patterns flown to a touch-and-go landing. Most missions of this type are pre-solo student sorties; hence, go-arounds (instructor or student initiated) or low approaches (runway supervisory unit directed) are often required. Normally, a maximum of two straight-in approaches will be accomplished. Since the most critical areas for student training are the final turn, final approach, and landings, closed traffic patterns are used to allow a greater number of repetitions of the critical areas. The mission concludes with a full-stop landing.
5. Breakout and Pattern Re-entry - occasionally, due to traffic conflict, breakout of the pattern is required. A mil power climb to a locally designated altitude is made. The aircraft then proceeds to a locally designated entry point where an idle power descent is made and the pattern re-entered.
6. Taxi/Engine Shutdown - begins when the aircraft clears the runway and ends when the engines are shut down. Requires completion of after landing check, taxi to the parking area, and completion of engine shutdown check.
7. Reserve - amount of fuel remaining for safety reasons, should any emergency/malfunction or other factor prevent landing at the home field when desired.

2. SINGLE AIRCRAFT UPT - SAMPLE ADVANCED CONTACT MISSION

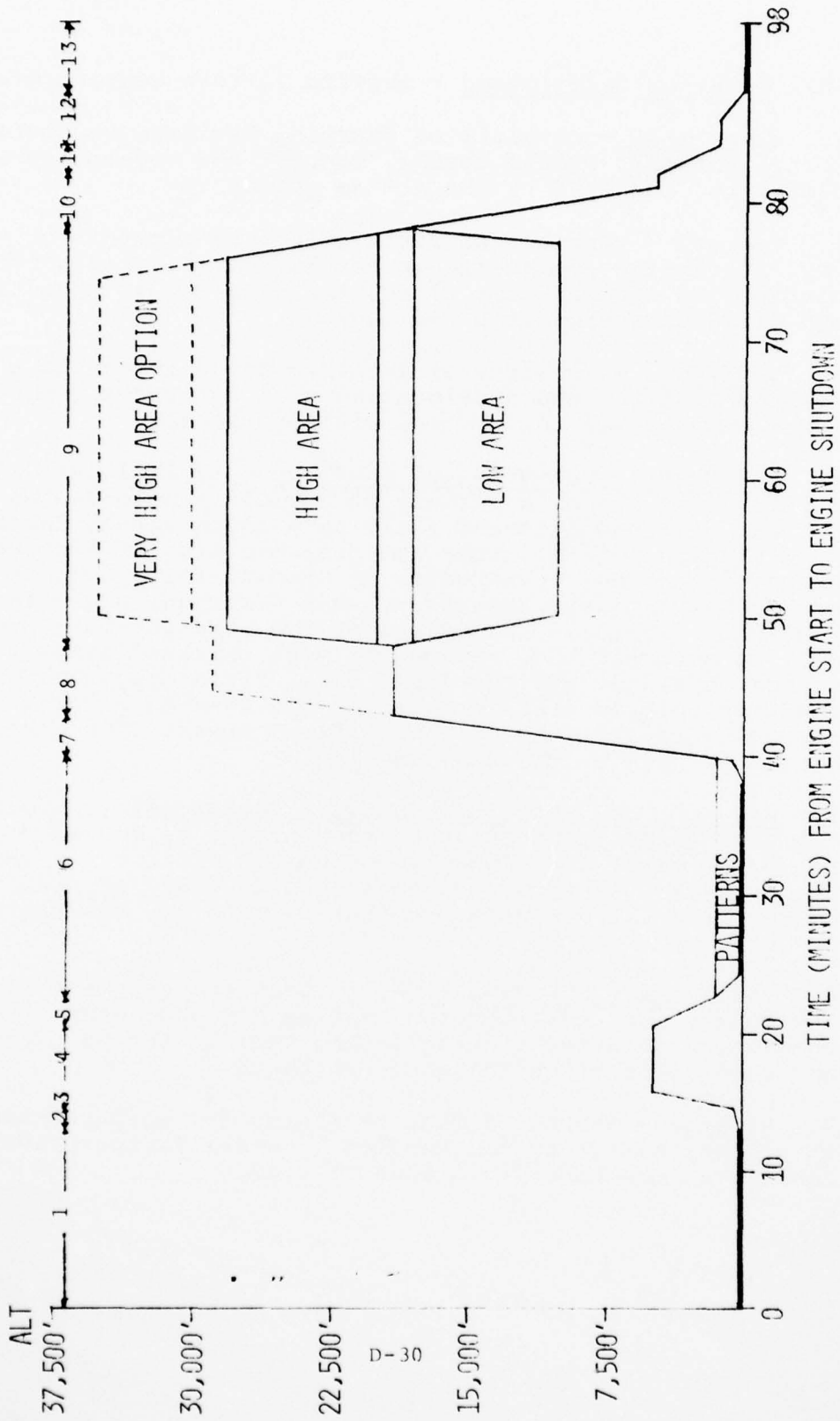

2A SINGLE AIRCRAFT UPT - SAMPLE ADVANCED CONTACT MISSION

General Description: This is the second of two contact mission extremes encountered in UPT. Mission profile may vary from that presented below, but generally consists of the following: takeoff from home field, climb to intermediate altitude, proceed to auxiliary airfield for pattern work, climb to assigned area for area work, descent, and return to home field for landing. An option of proceeding to the area from takeoff, then returning to home field for all pattern work will not be discussed.

	<u>Time and/or Distance</u>	<u>Altitude</u>	<u>Power Settings</u>
1. Start/taxi	12-15 min	0' AGL	Idle
2. Takeoff	1½ min	0-500' AGL	Max power
3. Climb/level-off	1 min	5,000' MSL	Mil power
4. Cruise to auxiliary field	5 min	5,000' MSL	Normal cruise
5. Descent/pattern entry	2 min	1,500' AGL	Idle
6. Traffic pattern work	15-20 min	1,500' to 0' AGL	Mil to idle
a. Straight-in approach			
b. Closed traffic pattern			
c. Normal touch-and-go landing			
d. Single engine touch-and-go landing			
e. No-flap touch-and-go landing			
f. Go-around (optional)			
g. Low approach (optional)			
7. Climb/level-off	3 min (4½ min - option)	19,000' MSL (29,000' MSL - option)	Mil
8. Cruise to area (optional)	5 min	19,000' MSL (29,000' MSL - option)	Normal cruise
9. Area work	25-35 min/ max distance from home field = 80 miles	10-18,000' MSL or 20-28,000' MSL or (30-35,000' MSL - option)	Idle to mil/max
a. Traffic pattern stalls			
b. Power on stalls			
c. Slow flight			
d. Inverted recovery			

UPT

Time and/or Distance                      Altitude                      Power Settings

e. Vertical recovery			
f. High speed dive recovery			
g. Aerobatics			
h. Max performance maneuvers			
10. Area exit/descent	3-5 min (7 min - option)	5,000' MSL	Idle to power on
11. Pattern entry	2 min	1,500' AGL	Power to hold 250 KIAS
12. Full stop landing	4 min	1,500' to 0' AGL	Power to hold 250 KIAS to idle
a. No-flap			
13. Taxi/engine shutdown	10 min	0' AGL	Idle
14. Reserve	20 min	10,000' MSL	Max endurance

AD-A053 374 AIR TRAINING COMMAND RANDOLPH AFB TX DIRECTOR OF OPE--ETC F/6 1/3  
ALTERNATIVES FOR FUTURE UNDERGRADUATE PILOT TRAINING, (U)  
APR 77 S 6 JOSEPH  
UNCLASSIFIED 77-1 NL

3 OF 3  
AD  
A053374

The microfiche card contains a grid of frames. The top row contains 12 frames, with the first frame containing the document header and the last frame containing the code 'NL'. The second row contains 12 frames of text. The third row contains 12 frames of text. The fourth row contains 12 frames of text. The fifth row contains 12 frames of text. The sixth row contains 12 frames of text. The seventh row contains 12 frames of text. The eighth row contains 12 frames of text. The ninth row contains 12 frames of text. The tenth row contains 12 frames of text. The eleventh row contains 12 frames of text. The twelfth row contains 12 frames of text. The thirteenth row contains 12 frames of text. The fourteenth row contains 12 frames of text. The fifteenth row contains 12 frames of text. The sixteenth row contains 12 frames of text. The seventeenth row contains 12 frames of text. The eighteenth row contains 12 frames of text. The nineteenth row contains 12 frames of text. The twentieth row contains 12 frames of text. The twenty-first row contains 12 frames of text. The twenty-second row contains 12 frames of text. The twenty-third row contains 12 frames of text. The twenty-fourth row contains 12 frames of text. The twenty-fifth row contains 12 frames of text. The twenty-sixth row contains 12 frames of text. The twenty-seventh row contains 12 frames of text. The twenty-eighth row contains 12 frames of text. The twenty-ninth row contains 12 frames of text. The thirtieth row contains 12 frames of text. The thirty-first row contains 12 frames of text. The thirty-second row contains 12 frames of text. The thirty-third row contains 12 frames of text. The thirty-fourth row contains 12 frames of text. The thirty-fifth row contains 12 frames of text. The thirty-sixth row contains 12 frames of text. The thirty-seventh row contains 12 frames of text. The thirty-eighth row contains 12 frames of text. The thirty-ninth row contains 12 frames of text. The fortieth row contains 12 frames of text. The forty-first row contains 12 frames of text. The forty-second row contains 12 frames of text. The forty-third row contains 12 frames of text. The forty-fourth row contains 12 frames of text. The forty-fifth row contains 12 frames of text. The forty-sixth row contains 12 frames of text. The forty-seventh row contains 12 frames of text. The forty-eighth row contains 12 frames of text. The forty-ninth row contains 12 frames of text. The fiftieth row contains 12 frames of text. The fifty-first row contains 12 frames of text. The fifty-second row contains 12 frames of text. The fifty-third row contains 12 frames of text. The fifty-fourth row contains 12 frames of text. The fifty-fifth row contains 12 frames of text. The fifty-sixth row contains 12 frames of text. The fifty-seventh row contains 12 frames of text. The fifty-eighth row contains 12 frames of text. The fifty-ninth row contains 12 frames of text. The sixtieth row contains 12 frames of text. The sixty-first row contains 12 frames of text. The sixty-second row contains 12 frames of text. The sixty-third row contains 12 frames of text. The sixty-fourth row contains 12 frames of text. The sixty-fifth row contains 12 frames of text. The sixty-sixth row contains 12 frames of text. The sixty-seventh row contains 12 frames of text. The sixty-eighth row contains 12 frames of text. The sixty-ninth row contains 12 frames of text. The seventieth row contains 12 frames of text. The seventy-first row contains 12 frames of text. The seventy-second row contains 12 frames of text. The seventy-third row contains 12 frames of text. The seventy-fourth row contains 12 frames of text. The seventy-fifth row contains 12 frames of text. The seventy-sixth row contains 12 frames of text. The seventy-seventh row contains 12 frames of text. The seventy-eighth row contains 12 frames of text. The seventy-ninth row contains 12 frames of text. The eightieth row contains 12 frames of text. The eighty-first row contains 12 frames of text. The eighty-second row contains 12 frames of text. The eighty-third row contains 12 frames of text. The eighty-fourth row contains 12 frames of text. The eighty-fifth row contains 12 frames of text. The eighty-sixth row contains 12 frames of text. The eighty-seventh row contains 12 frames of text. The eighty-eighth row contains 12 frames of text. The eighty-ninth row contains 12 frames of text. The ninetieth row contains 12 frames of text. The ninety-first row contains 12 frames of text. The ninety-second row contains 12 frames of text. The ninety-third row contains 12 frames of text. The ninety-fourth row contains 12 frames of text. The ninety-fifth row contains 12 frames of text. The ninety-sixth row contains 12 frames of text. The ninety-seventh row contains 12 frames of text. The ninety-eighth row contains 12 frames of text. The ninety-ninth row contains 12 frames of text. The hundredth row contains 12 frames of text.

END  
DATE  
FILMED  
6-78  
DDC

2B. Maneuver Description - Advanced Contact Mission

1. Start/Taxi - previously explained/self-explanatory.
2. Takeoff - previously explained/self-explanatory.
3. Climb/Level-off - generally consists of climbing the aircraft at its best climb speed and leveling off at a locally specified altitude.
4. Cruise to Auxiliary Airfield - normal cruise along a locally designated ground path to an auxiliary airfield.
5. Descent/Pattern Entry - previously explained/self-explanatory.
6. Traffic Pattern Work - time spent at the auxiliary airfield is inversely proportional to the skill level of the student. There is no set pattern for ordering traffic patterns, but generally, the sequence is as follows (for an advanced student): straight-in approach, normal overhead pattern, single-engine overhead pattern, no-flap overhead pattern. One of the overhead patterns in the sequence is normally reserved for the full stop landing at the home field. Go-arounds and low approaches are flown when necessary. To save time, most overhead patterns are flown using a closed traffic pattern entry.
7. Climb/Level-off - consists of departing the auxiliary field and climbing to the locally designated point where an assigned area can be entered. Climb is at best climb speed. An optional climb to a very high area is shown, in the event that: (a) aircraft performance permits, and (b) use of very high areas necessary due to airspace congestion.
8. Cruise to Area - optional, since some local area procedures allow climb direct to an area. Generally, however, some level cruising, at normal cruise, is encountered prior to reaching the assigned area.
9. Area Work - begins with a change of power to enter the assigned area and ends with a power change to exit the assigned area. Includes the performance of required maneuvers, and time to analyze, set up, and critique those maneuvers. An absolute minimum of 200 square miles of airspace are required for each area. Areas would probably be stratified into high (20-28,000') and low (10-18,000') blocks for maximum utilization of airspace. A very high block of airspace, if needed, would range from 30-35,000'.
10. Area Exit/Descent - consists of a descent to a locally designated altitude, and compliance with a locally designated return route. A climb may be necessary from a low area, but normal area exit requires an idle to reduced power letdown.
11. Pattern Entry - previously explained/self-explanatory.
12. Full Stop Landing - consists normally of the overhead pattern not accomplished at the auxiliary airfield.
13. Taxi/Engine Shutdown - previously explained/self-explanatory.
14. Reserve - previously explained/self-explanatory.

3. SINGLE AIRCRAFT IPT - SAMPLE BASIC MISSION

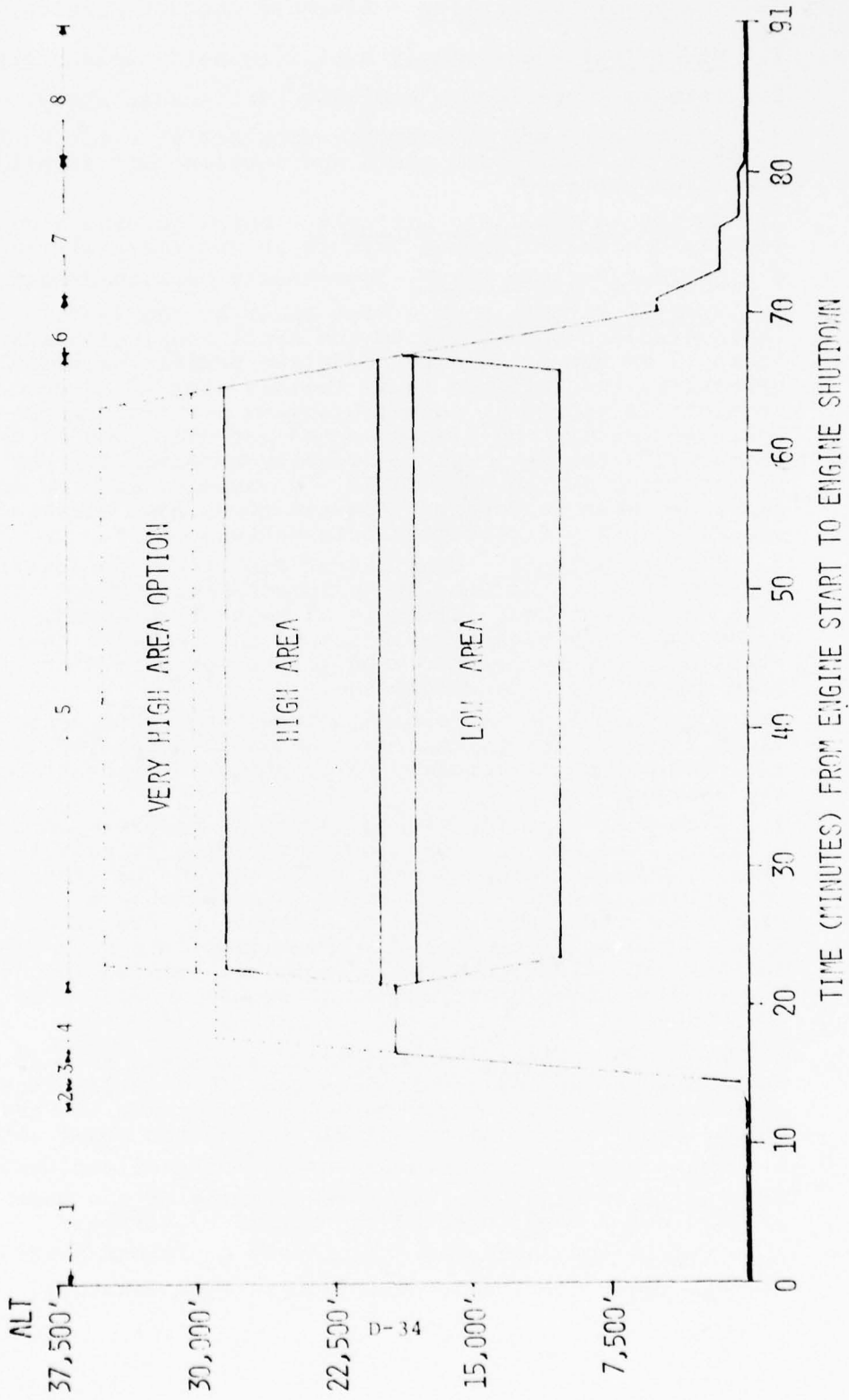

3A SINGLE AIRCRAFT UPT - SAMPLE BASIC MISSION

General Description: Basic category missions teach student pilots basic flying skills which are prerequisites to learning more advanced maneuvers in the contact and instrument categories. Consists of a departure to a local flying area, basic maneuvers performed in that area, and return to the home field for landings.

	<u>Time and/or Distance</u>	<u>Altitude</u>	<u>Power Settings</u>
1. Start/Taxi	12-15 min	0' AGL	Idle
2. Takeoff	1½ min	500' AGL	Max power
3. Climb/Level-off	3 Min (4½ min - Option)	19,000' MSL (29,000' MSL - Option)	Mil power
4. Area entry	5 min	19,000' MSL (29,000' MSL - Option)	Normal cruise
5. Area work	40-45 min/max distance from home field = 80 miles	10-18,000' MSL or 20-23,000' MSL or (30-35,000' MSL - Option)	Idle to mil
<ul style="list-style-type: none"> <li>a. Climbs and descents (rate and constant airspeed)</li> <li>b. Turns (normal, medium, steep)</li> <li>c. Airspeed changes</li> <li>d. Straight and level</li> </ul>			
6. Area exit/descent	3-5 min (7 min-Option)	5,000' MSL	Idle to power on
7. Pattern entry and landings	10 min	5,000' MSL to 0' AGL	Normal cruise to idle
<ul style="list-style-type: none"> <li>a. Straight-in approach</li> <li>b. Full stop landing</li> </ul>			
8. Taxi/engine shutdown	10 min	0' AGL	Idle
9. Reserve	20 min	10,000' MSL	Max endurance

3B. Maneuver Description - Basic Mission

1. Start/Taxi - previously explained/self-explanatory.
2. Takeoff - previously explained/self-explanatory.
3. Climb/Level-off - consists of climbing the aircraft at best mil power rate of climb to a desired altitude, leveling the aircraft at that altitude, and accelerating to a desired cruise air-speed. Power must be set from mil to cruise power setting.
4. Area Entry - consists of flying the aircraft from the point of level off to the locally designated point where an assigned area can be entered. The very high area option has been previously explained.
5. Area Work - generally consists of basic flying maneuvers, such as climbs, descents, turns, which are prerequisites to learning more advanced maneuvers in the contact and instrument categories. Primary purpose of this category is to teach student pilots pitch, bank, and power techniques.
6. Area Exit/Descent - consists of a descent to a locally designated altitude and compliance with a locally designated return route. A climb may be necessary from a low area, but normal area exit entails an idle to reduced power letdown.
7. Pattern Entry/Landing - consists of complying with locally designated return route to arrive at a point where a straight-in approach to a full stop landing can be made to the home field. A possible option is for several overhead, normal traffic patterns to be flown towards the end of the basic category.
8. Taxi/Engine Shutdown - previously explained/self-explanatory.
9. Reserve - previously explained/self-explanatory.

4. SINGLE AIRCRAFT UPT - SAMPLE ADVANCED INSTRUMENT MISSION

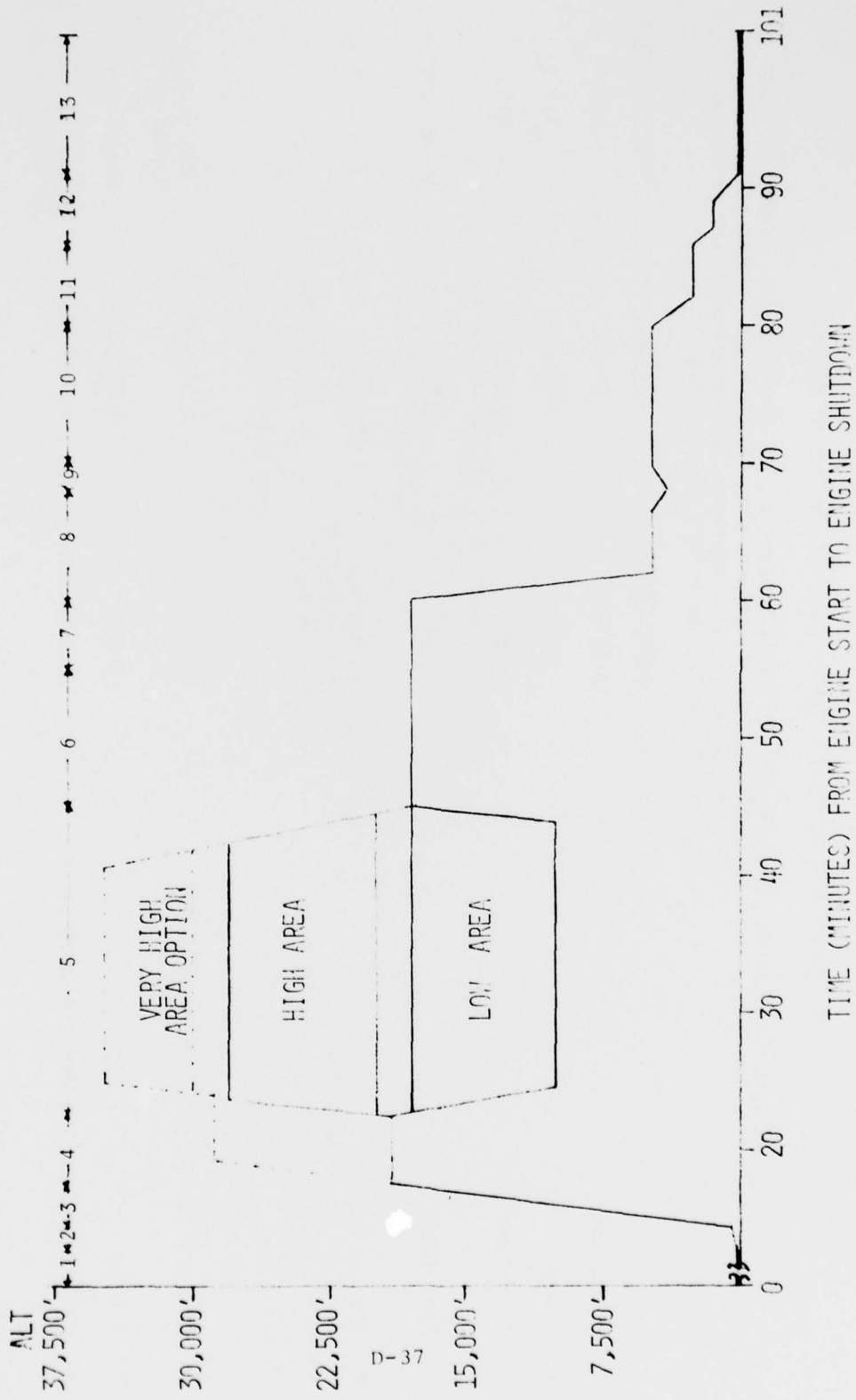

TIME (MINUTES) FROM ENGINE START TO ENGINE SHUTDOWN

4A SINGLE AIRCRAFT UPT - SAMPLE ADVANCED INSTRUMENT MISSION

General Description: Mission profile generally consists of the following: takeoff, climb to local area for instrument work, TACAN or VOR holding pattern, TACAN or VOR penetration, approach, missed approach, and precision approach (PAR or ILS) to a full stop landing.

	<u>Time and/or Distance</u>	<u>Altitude</u>	<u>Power Settings</u>
1. Start/taxi	12-15 min	0' AGL	Idle
2. Takeoff	1½ min	500' AGL	Max
3. Climb/level-off	3 min (4½ min - option)	19,000' MSL (29,000' MSL - option)	Mil
4. Area entry	5 min	19,000' MSL (29,000' MSL - option)	Normal cruise
5. Area work	20-25 min/max distance from home field = 80 miles	10-18,000' MSL or 20-28,000' MSL or (30-35,000' MSL - option)	Idle to mil
a. Confidence maneuvers			
b. Unusual attitudes			
c. Point-to-point			
d. Course maneuvers			
e. Arc maneuvers			
6. Area exit/cruise to TACAN or VOR IAF	10 min	18,000' MSL	Mil/idle to normal cruise
7. Holding	5 min	18,000' MSL	Normal cruise
8. TACAN or VOR penetration and approach	8 min	4,000' MSL	Reduced to landing configuration power
9. Missed approach/climb	2 min	5,000' MSL	Mil
10. Cruise to home field	10 min	5,000' MSL	Normal cruise
11. GCA pattern	6 min	2,500' AGL	Low cruise
12. PAR or ILS approach and landing	5 min/10 miles	1,500' AGL	Landing configuration power to idle

	<u>Time and/or Distance</u>	<u>Altitude</u>	<u>Power Settings</u>
13. Taxi/engine shutdown	10 min	0' AGL	Idle to taxi power
14. Reserve	20 min	10,000' MSL	Max endurance

4B. Maneuver Description - Instrument Mission

1. Start/Taxi - previously explained/self-explanatory.
2. Takeoff - previously explained/self-explanatory.
3. Climb/Level-off - previously explained/self-explanatory.
4. Area Entry - previously explained/self-explanatory.
5. Area Work - consists of the following maneuvers, performed in any sequence: confidence maneuvers (wingover, aileron roll), unusual attitudes (climb and dive recoveries, upright and inverted), point-to-point, course interception and course maintaining, arc interception and maintaining arc. Area size should be 200 square miles.
6. Area Exit/Cruise to TACAN or VOR IAF - exit assigned high/low area and descent/climb to locally designated altitude. Proceed at normal cruise to TACAN or VOR Initial Approach Fix (IAF).
7. Holding - student pilots are normally required to perform this maneuver on every ride requiring a TACAN/VOR penetration and approach. TACAN holding patterns may or may not be located over the TACAN station. VOR holding patterns are normally located over the VOR. Time permitting, students may be required to fly more than one holding pattern, adjusting speed to meet a known expected approach clearance time. If a crew is established in holding, subsequent crews will be assigned higher holding altitudes (1000' increments). Two possible holding options that will not be discussed are: holding in assigned area, and holding over a TACAN/VOR other than the home field TACAN/VOR.
8. TACAN or VOR Penetration and Approach - generally starts with a reduced power descent from the IAF, usually with extended speedbrakes and 250 KIAS. Generally requires that the aircraft fly outbound from the IAF for at least half of the desired altitude to be lost, then turn inbound to the TACAN/VOR while descending to the required altitude. When IAF is not collocated with a TACAN station, the penetration may be a straight descent to the final approach fix. A third option would require intercepting and maintaining an arc until reaching the final approach course. Aircraft must be partially configured for landing (normally gear and landing lights) prior to descending to minimum approach altitude. The flaps and speedbrake are not normally lowered due to the approach being concluded with a missed approach rather than a landing. The option of flying a TACAN/VOR penetration and approach at other than the home field will not be discussed.

9. Missed Approach/Climb - maneuver which is designed to get an aircraft to a safe altitude and area to start a second approach for landing or a divert to an alternate airfield. In UPT, this maneuver is flown on most instrument missions to improve student proficiency. Consists of a mil power climb, retracting landing gear and lights, reduced power climb (once desired climb airspeed has been reached), and a level-off at an airspeed that facilitates beginning the next approach (or cruise, in the case of a divert).

10. Cruise to Home Field - used if TACAN or VOR penetration and approach are flown at other than the home field. Normally, use best cruise.

11. GCA Pattern - consists of either a rectangular or straight-in series of vectors, directed by approach control personnel, using surveillance radar. Purpose of the approach is to get the aircraft sequenced with other landing traffic and turned on to a precision final approach approximately 10 miles prior to touchdown. Generally, one or two descents are required and initial landing configuration is attained prior to final approach (landing gear, flaps, and landing lights). Power is used as necessary to hold landing configuration airspeed.

12. PAR or ILS Approach and Landing - consists of getting the aircraft on the ground from an approximate 10 mile final by either precision approach radar (PAR - flown by the pilot, directed by a ground based final controller) or by Instrument Landing System (ILS - flown by the pilot, directed by instrumentation). At most UPT bases, these approaches are flown to a full stop landing. Final configuration for landing (speedbrakes) is usually made when final descent for landing begins. Continual, small power changes are required to maintain final approach airspeed and rate of descent.

13. Taxi/Engine Shutdown - previously explained/self-explanatory.

14. Reserve - previously explained/self-explanatory.

5. SINGLE AIRCRAFT UPT - SAMPLE LOW-LEVEL VFR NAVIGATION MISSION

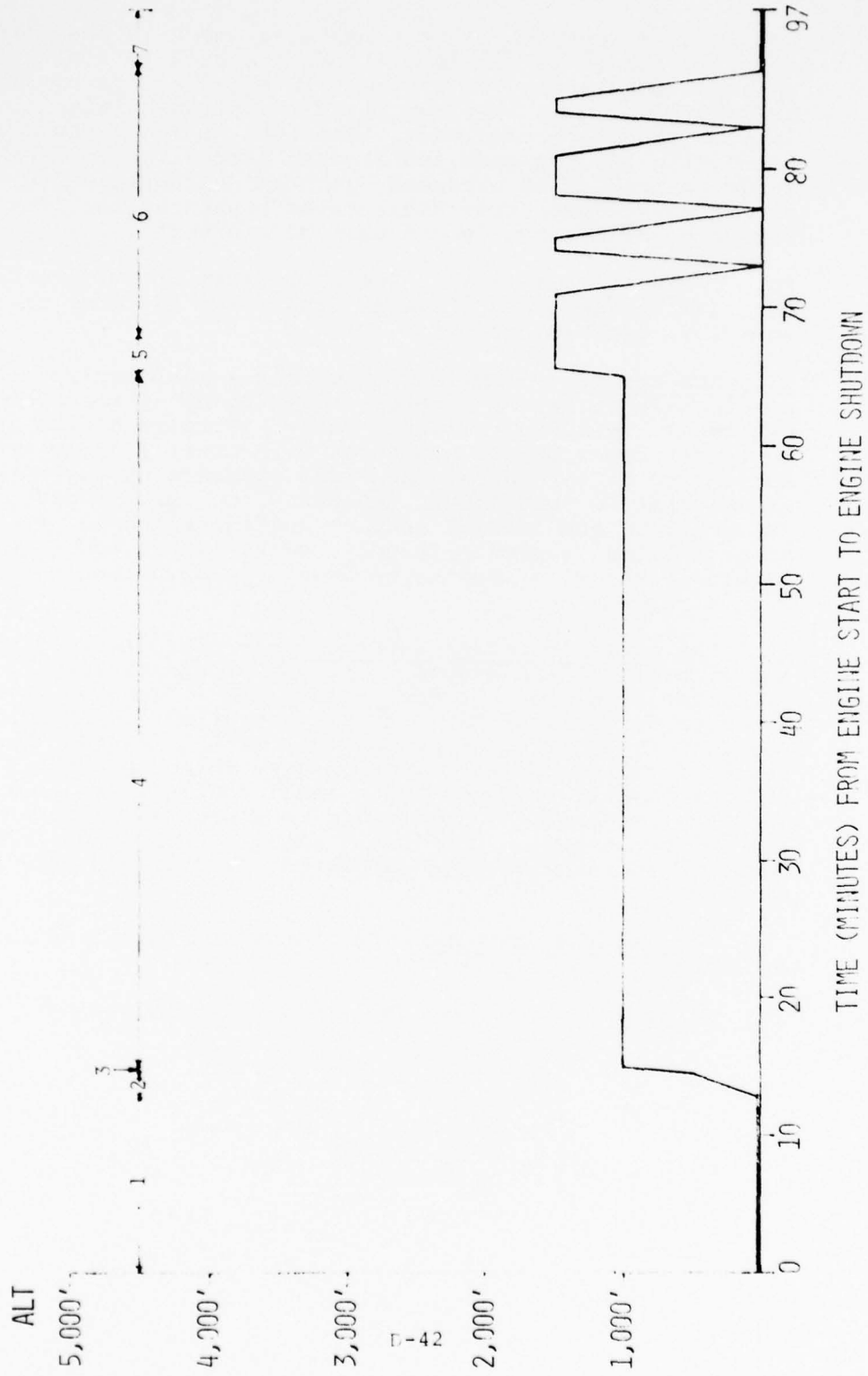

5A SINGLE AIRCRAFT UPT - SAMPLE LOW-LEVEL VFR NAVIGATION MISSION

General Description: This is one of two navigation profile extremes that could be encountered in UPT. Mission consists of departure from home field, climb to cruise altitude, navigation practice along a pre-planned route of flight, and VFR pattern work at the destination base.

	<u>Time and/or Distance</u>	<u>Altitude</u>	<u>Power Settings</u>
1. Start/taxi	12-15 min	0' AGL	Idle
2. Takeoff	1½ min	500' AGL	Max
3. Climb/level-off	1/2 min	1,000' AGL	Power to hold 360 KIAS
4. Navigate VFR	50 min/approx 300 miles	1,000' AGL	Power to hold 360 KIAS
5. Destination Arrival	3 min (15 miles)	1,500' AGL	Cruise to mil to power to hold 250 KIAS
6. Traffic patterns	15-20 min	1,500' AGL to 0' AGL	Mil to idle
a. Overhead pattern			
b. Touch-and-go landings			
c. Closed pattern			
d. Full stop landing			
7. Taxi/engine shutdown	10 min	0' AGL	Idle
8. Reserve	20 min	10,000' MSL	Max endurance

5B. Maneuver Description - Low-Level VFR Navigation Mission

1. Start/Taxi - previously explained/self-explanatory.
2. Takeoff - previously explained/self-explanatory.
3. Climb/Level-off - climb from attainment of climb air-speed to a pred. terminated altitude and ground track. Requires acceleration after level-off to cruise airspeed.
4. Navigate VFR - student is required to fly a preplanned route using visual references and an area map. Normally, aircraft will not deviate from planned ground track. Power changes only required to adjust ground speed to make planned times over several check points.
5. Destination/Arrival - includes a climb to traffic pattern altitude, determining correct runway for landing, and maneuvering the aircraft to an initial. Changes in air-speed from cruise, to climb, to traffic pattern speed are required and may require corresponding power changes.
6. Traffic Patterns - previously explained/self-explanatory. Normally, practice emergency traffic patterns (single-engine and no-flap) will not be flown.
7. Taxi/Engine Shutdown - previously explained/self-explanatory.
8. Reserve - previously explained/self-explanatory.

6. SINGLE AIRCRAFT UPT - SAMPLE IFR NAVIGATION MISSION

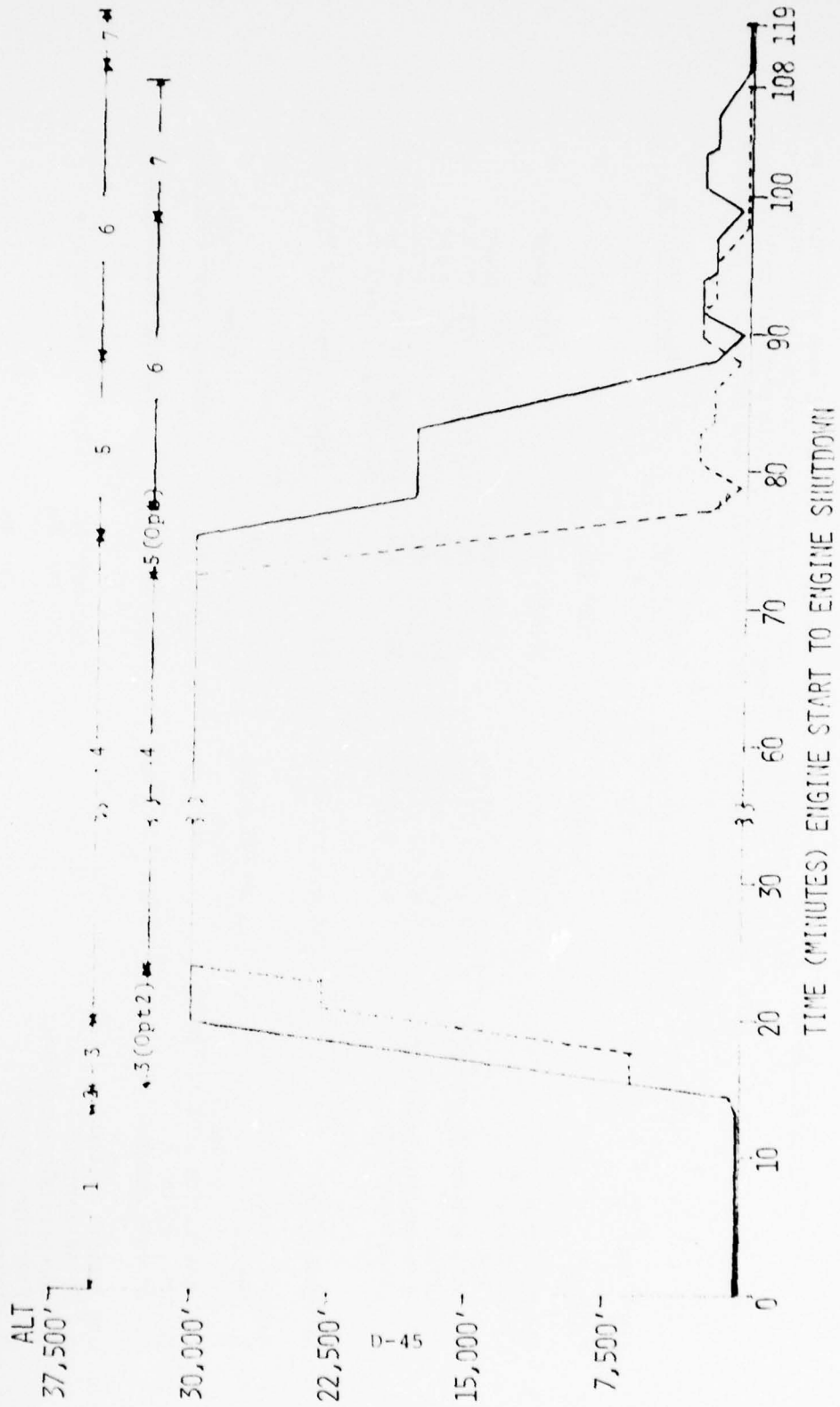

6A SINGLE AIRCRAFT UPT - SAMPLE IFR NAVIGATION MISSION

General Description - This is the second of two navigation mission extremes encountered in UPT. Mission consists of departure from home or strange field, climb to cruise altitude, navigation along a pre-planned route of flight using IFR procedures, descent to destination field, and IFR pattern work at the destination base.

	<u>Time and/or Distance</u>	<u>Altitude</u>		<u>Power Settings</u>	
		0' AGL	500' AGL	Idle	Max
1. Start/taxi	12-15 min				
2. Takeoff	1½ min		500' AGL		Max
3. Climb, Option 1	5 min/38 miles		30,000' MSL		Mil power
Climb, Option 2					
a. Climb:	1 min/ 7 miles		6,000' MSL		Mil power
b. Intermediate level-off	2 min/15 miles		6,000' MSL		Best cruise
c. Climb	3 min/23 miles		23,000' MSL		Mil power
d. Intermediate level-off	2 min/15 miles		23,000' MSL		Best cruise
e. Climb/level off	1 min/ 8 miles		30,000' MSL		Mil power to hold approx 440 KTAS, .75 mach (std day, no wind)
4. Navigate (IFR)	55 min/400 miles		30,000' MSL		Power to hold 440 KTAS, .75 mach
5. Descent, Option 1					
a. Descent	3 min/35 miles		18,000' MSL		Idle
b. Holding (optional)	5 min		18,000' MSL		Normal cruise
c. Penetration (VOR or TACAN)	5 min		2,000' AGL		Reduced power (250 KIAS)
Descent, Option 2					
a. Enroute descent	5 min/70 miles		2,000' AGL		Idle to reduced power
6. IFR traffic patterns					
a. First approach	2 min		2,000-400' AGL		Mil to idle
b. Non-precision approach	7 min		2,500-400' AGL		
c. Precision approach	7 min		2,500-100' AGL		
d. Missed approach	2 min		100-2,500' AGL		
e. Full stop landing	1 min		0' AGL		
7. Taxi/engine shutdown	10 min		0' AGL		Idle
8. Reserve	20 min		10,000' MSL		Max endurance

6B. Maneuver Description - IFR Navigation Mission

1. Start/Taxi - previously explained/self-explanatory.
2. Takeoff - previously explained/self-explanatory.
3. Climb (Option 1) - mil power climb by either standard instrument departure (SID) or radar monitored departure to first fix on a preplanned and air traffic control approved IFR route. Altitude of 30,000' chosen because of understanding that 30,000' is the most efficient altitude for high-bypass turbofan engines. This option includes a level-off and acceleration to planned cruise airspeed (approx .75 mach, 440 KTAS standard day, no wind).

Climb (Option 2) - same as above, except that intermediate altitudes may be assigned/required by either a SID/ departure controller and/or by the low altitude sector controller prior to reaching cruise altitude in the high sector.

4. Navigate (IFR) - student is required to fly a pre-planned route. Deviations from planned route, altitude, or airspeed are not allowed except in the case of an emergency/malfunction or an Air Traffic Control request.
5. Descent (Option 1) - includes an en route descent to either holding pattern altitude or IAF altitude prior to starting a penetration to a final approach fix position and altitude from which an instrument approach may be flown to the destination base. Either a TACAN or VOR approach may be used.

Descent (Option 2) - includes an en route descent to an altitude and position from which an instrument approach may be flown to the destination base. Primary purpose of the en route descent is to save time and to conserve fuel. The approach flown could be any precision or nonprecision approach.

6. IFR Traffic Patterns - normally, two or three approaches - one or two nonprecision (VOR, TACAN, ASR) and one or two precision (PAR, ILS) - are flown prior to landing. The first one or two approaches are flown to minimums at which point a mil power missed approach (climb) is started and the aircraft positioned by approach control or navigational aids for the next approach.
7. Taxi/Engine Shutdown - previously explained/self-explanatory.
8. Reserve - previously explained/self-explanatory.

7. SINGLE AIRCRAFT UPT - SAMPLE FORMATION MISSION

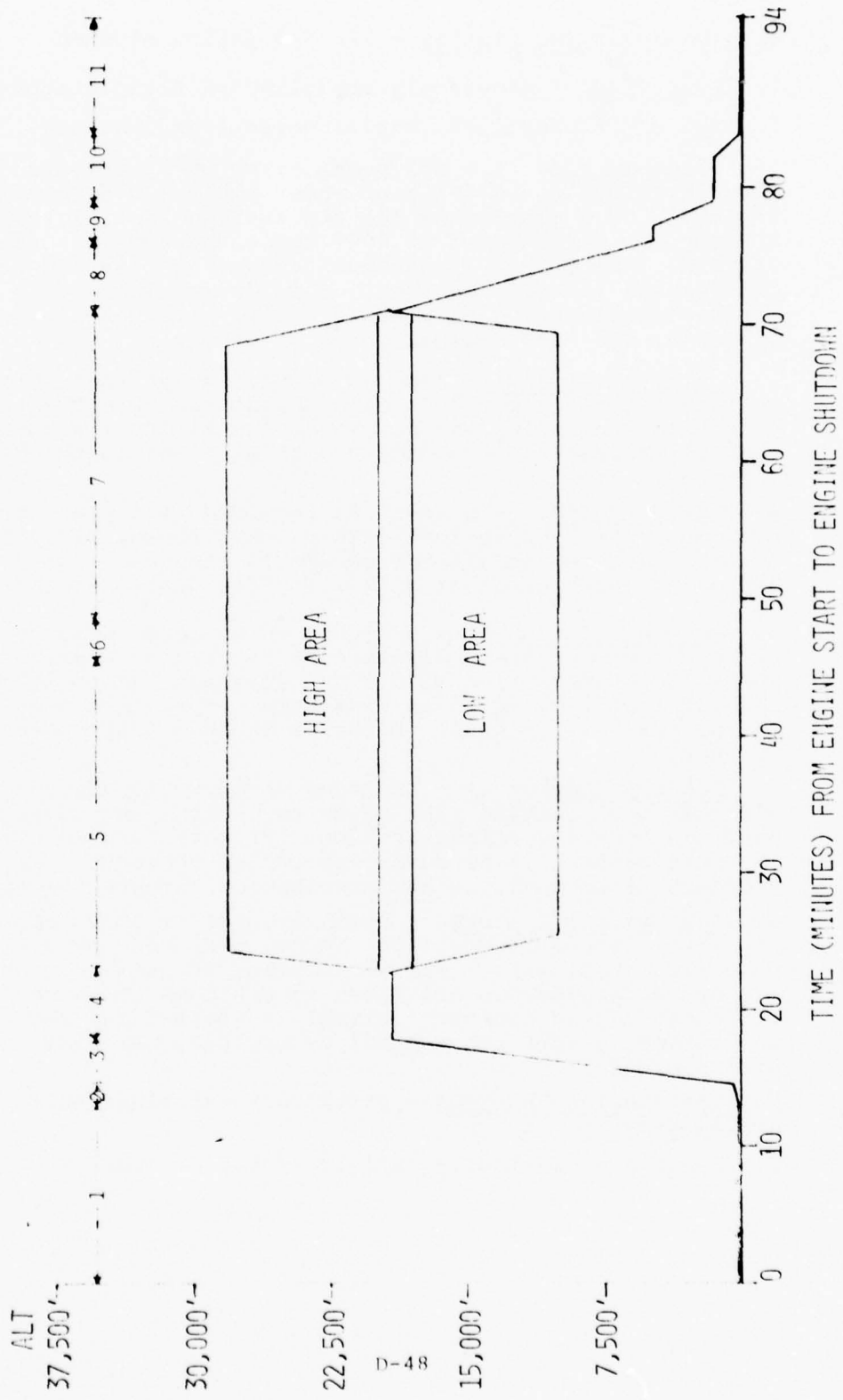

7A SINGLE AIRCRAFT UPT - SAMPLE FORMATION MISSION

General Description - Consists of two, three, or four aircraft taking off either in flights of two or singly, joining together, proceeding to a local area for formation maneuvers, exchanging positions to allow two aircraft equal practice in lead and wing positions, continuation of formation maneuvers, descent and return to home field for formation overhead pattern or straight-in landing (instrument or contact). The profile below is for a two-ship formation. Three and four-ship formation will only be mentioned where significant differences appear.

	<u>Time and/or Distance</u>	<u>Altitude</u>	<u>Power Settings</u>
1. Start/taxi	12-15 min	0' AGL	Lead: idle Wing: idle
2. Takeoff	1½ min (2-ship) 2 min (3/4-ship)	500' AGL	Lead: slightly less than max Wing: as required
3. Climb	3½ min	19,000' MSL	Lead: slightly less than mil Wing: as required
4. Cruise to area	5 min	19,000' MSL	Lead: normal cruise Wing: as required
a. Crossunders			
b. Route position			
5. Area work	20-25 min/max distance from home field = 80 miles	10-18,000' MSL or 20-28,000' MSL	Lead: normal cruise to best cruise Wing: idle to mil/max
a. Rejoins			
b. Finger-tip maneuvers			
c. Trail (close)			
d. Trail (extended) - 2-ship only			
6. Position change	3 min (2-ship) 4 min (3-ship) 5 min (4-ship)	10-18,000' MSL or	Lead: normal cruise to reduced power Wing: as required to normal cruise

	<u>Time and/or Distance</u>	<u>Altitude</u>	<u>Power Settings</u>
7. Area work (maneuvers are the same as in 5 above)	20-25 min	10-18,000' MSL or 20-28,000' MSL	Lead: normal cruise to best cruise Wing: idle to mil/max
8. Area exit/descent a. Crossunders b. Route position	4-6 min	5,000' MSL	Lead: reduced power (250 KIAS w/speed brake) Wing: as required (250 KIAS w/speed brake)
9. Pattern entry	3 min	1,500' AGL	Lead: power to hold 250 KIAS Wing: as required
10. Traffic pattern and landing	5 min (2-ship) 6 min (3/4-ship)	1,500' AGL to 0' AGL	Lead: power to hold 250 KIAS to idle Wing: as required to idle
11. Taxi/engine shutdown	10 min	0' AGL	Lead: idle Wing: idle
12. Reserve	20 min	10,000' MSL	Max endurance

7B Maneuver Description - Formation Mission

1. Start/Taxi - previously explained/self-explanatory
2. Takeoff - requires very slightly more time than single-ship takeoff due to lead aircraft using slightly less than max power. This reduced power gives the wingman a catch-up capability. Second element in a 3/4-ship formation does not release brake until 12 seconds after first element started takeoff roll.
3. Climb - requires slightly more time than single ship climb due to lead aircraft using slightly less than mil power. Wingman uses power as required to maintain position.
4. Cruise to area - Lead uses normal cruise power, wingman uses power as necessary to stay in fingertip (3' wingtip clearance) position. Crossunder and route position maneuvers normally occur during this portion of the mission. Crossunders require more power adjustments than that required to stay in fingertip. Route position, used for performing checks, is a widened formation. Wingman must vary power slightly to move out to and in from route position.
5. Area Work - Formation maneuvers require that the leader take the formation through a wide range of airspeed, pitch, and bank to allow the wingman to build up proficiency in maintaining proper position (3 and 4-ship parameters are not as wide as 2-ship). Power changes by a wingman with a low level of proficiency could conceivably range from idle to max, while those of a highly proficient wingman might not vary from lead's set power by more than  $\pm 5\%$  (slightly more in 3 and 4-ship). Rejoins are used to practice reforming a formation once it has separated. Generally requires that lead and wing separate by delaying pitchouts ( $60^{\circ}$  bank,  $180^{\circ}$  turn). Lead then either maintains straight and level at a prebriefed airspeed, or a level, shallow banked turn at a prebriefed airspeed (prebriefed airspeed generally close to normal cruise). The wingman must rejoin to a fingertip position by varying bank, power, and pitch as necessary. Close trail formation requires that a wingman "follow the leader" from a position that is similar to the refueling position used by fighter aircraft (nose-tail). Once the leader ascertains that his wingman is in position, he takes the formation through a series of varied pitch and bank maneuvers to build up the wingman's proficiency (3 and 4-ship parameters are not as wide as 2-ship). The wingman must use pitch, bank, and power as necessary to stay in position. Extended trail formation (2-ship only) requires that the wingman follow the leader from an extended position (1000-1500' aft). The object is for the wingman to maintain his position by varying pitch and bank within a  $90^{\circ}$  cone behind the leader without using power. The minimum area size for formations is 300 square miles in a low area and 600 square miles in a high area due to a formation not being as maneuverable as a single aircraft. Use of a very high area for formations is not considered an option.

6. Position Change - requires that the formation spread apart and a position change be directed by the leader. When the wingman is ready to assume lead duties, he informs the leader, who slides back to a wing position. The formation is directed to close position and continues with area maneuvers under the direction of the new leader. Power changes are very minimal. The change is normally made from a straight-and-level position. Three and four-ship position changes require more time to complete than 2-ship.
7. Area Work - previously explained/self-explanatory.
8. Area Exit/Descent - consists of a reduced power descent. Speed brakes may be used to increase rate of descent. Crossunder exercises are normally accomplished, and route position is used to accomplish required checks. Although not discussed in this profile, a formation may proceed to a local VOR or TACAN for formation instrument approach practice (3 and 4-ship formations must break up for instrument practice; 2-ship only).
9. Pattern Entry - the wingman must be positioned on the side of lead opposite the direction of the traffic pattern. Low altitude turns are usually echelon turns (wingman remains level with lead, matches his bank, and uses power to maintain position).
10. Traffic Pattern and Landing - the formation separates at the pitch point by wingman delaying pitchout after the leader. Each aircraft flies its own pattern and landing, except that lead flies a slightly tighter pattern than normal and the wingman may loosen his pattern slightly to gain proper spacing. Three and four-ship formations require slightly more time for this maneuver.
11. Taxi/Engine Shutdown - aircraft taxi as a formation.
12. Reserve - previously explained/self-explanatory.

XT-3 - SAMPLE IFR NAVIGATION MISSION

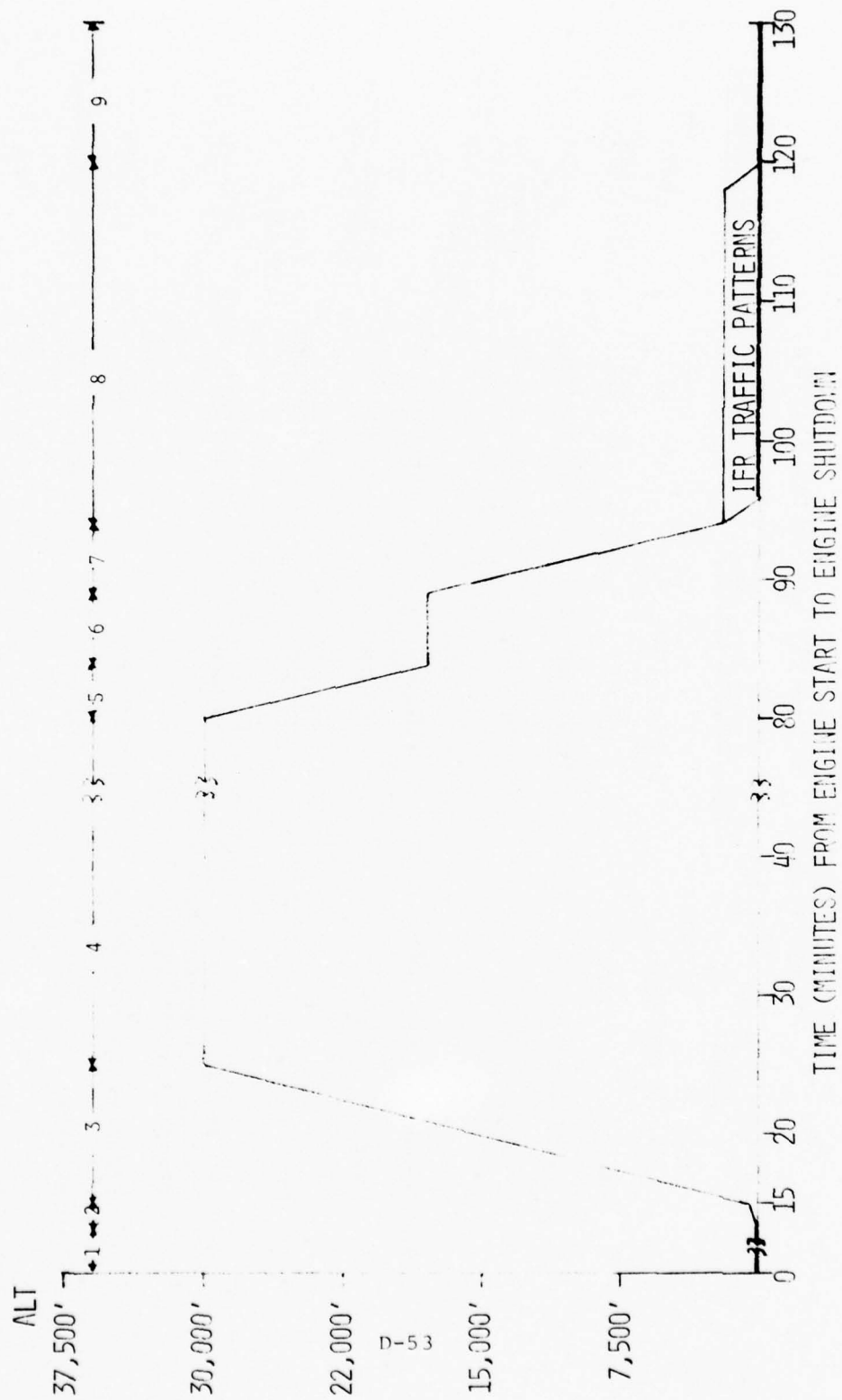

TTB TRAINER - SAMPLE IFR NAVIGATION MISSION

<u>Task</u>	<u>Time and/or Distance</u>	<u>Altitude</u>	<u>Power Setting</u>
1. Engine Start/Taxi	10-15 min	0' AGL	Idle
2. Takeoff	2 min	500' AGL	Mil
3. Climb/Level-off	10 min/40 mi	30,000' MSL	Mil
4. Navigate (IFR)	55 min/400 mi	30,000' MSL	Power to Hold .70-.75 (410-440 KTAS)
5. Descent	4 min/40 mi	18,000' MSL	Idle
6. Holding	5 min	18,000' MSL	Reduced Power (200-250 KTAS)
7. Penetration	5 min	2,000' MSL	Idle to Reduced Power
8. IFR Traffic Patterns (4 approaches minimum) & landings	26 min	2,500'-0' AGL	Idle to Mil
9. Taxi/Engine Shutdown	10 min	0' AGL	Idle
10. Reserve	20 min	10,000' MSL	Max Endurance

APPENDIX E

FUPT SYLLABI

The syllabi presented in this appendix represent "best guess" estimates of UPT syllabi for each of the training system alternatives considered. It must be recognized that these are projected syllabi only and would require validation prior to actual implementation.

Dynamic observer sorties/hours do not count toward career flying time. These sorties utilize empty seats to provide additional flying exposure.

Copilot sorties/hours count toward career flying time. These sorties are flown "right-seat" in the TTB basic phase, while Dual and Team designated sorties are flown "left seat."

XT-1/T-38 Syllabus

<u>Category</u>	<u>Dual</u>	<u>Solo</u>	<u>(Dynamic) (Observer)</u>	<u>Total</u>
1. XT-1 Primary Phase:				
a. Simulator	27/35.3			27/35.3
b. Aircraft(XT-1)				
Contact	28/37.2	11/13.6	4/(5.2)	39/50.8
Instruments	2/2.8			2/2.8
Formation	10/13.0	3/3.9		13/16.9
Navigation	7/9.8			7/9.8
				<u>61/80.3</u>
2. T-38 Basic Phase:				
a. Simulator	28/36.4			28/36.4
b. Aircraft(T-38)				
Contact	23/27.6	6/7.2	3/(3.6)	29/34.8
Instruments	2/2.6			2/2.6
Formation	15/18.0	8/9.6	5/(6.0)	23/27.6
Navigation	16/20.9	4/5.6	2/(2.8)	20/26.5
				<u>74/91.5</u>

XT-2 Syllabus

1. Simulator	58/76.1			58/76.1
2. Aircraft(XT-2)				
Contact	39/50.5	21/27.3	11/(14.3)	60/77.8
Instruments	3/4.5			3/4.5
Formation	27/30.0	11/12.5	7/(8.4)	38/42.5
Navigation	19/21.0	6/8.3	1/(1.5)	25/29.3
				<u>126/154.1</u>

XT-3 (or XT-1)/XT-3/T-38 Syllabus

<u>Category</u>	<u>Dual</u>	<u>Solo</u>	<u>(Dynamic) (Observer)</u>	<u>Total</u>
1. Primary Phase:				
a. Simulator	27/35.3			27/35.3
b. Aircraft (XT-1 or XT-3)				
Contact	28/37.2	11/13.6	4/(5.2)	39/50.8
Instruments	2/2.8			2/2.8
Formation	10/13.0	3/3.9		13/16.9
Navigation	7/9.8			7/9.8
				<u>61/80.3</u>

2. FAIR Basic Phase:

a. Simulator	28/36.4			28/36.4
b. Aircraft (T-38)				
Contact	23/27.6	6/7.2	3/(3.6)	29/34.8
Instruments	2/2.6			2/2.6
Formation	15/18.0	8/9.6	5/(6.0)	23/27.6
Navigation	16/20.9	4/5.6	2/(2.8)	20/26.5
			Sub-Total	<u>74/91.5</u>
Tactical*	12/13.2			<u>12/13.2</u>
				<u>86/104.7</u>

<u>Category</u>	<u>Dual</u>	<u>Team</u>	<u>(Co-Pilot)</u>	<u>Total</u>
3. TTB Basic Phase				
a. Simulator	28/36.4			28/36.4
b. Aircraft (XT-3)				
Contact	6/9.0	12/18.0	18/(27.0)	18/27.0
Instruments	2/3.0		2/(3.0)	2/3.0
Formation	4/6.4	1/1.6	5/(8.0)	5/8.0
Navigation	12/18.9	10/14.1	22/(33.0)	22/33.0
				<u>47/71.0</u>

\* Tactical Category adds 13.2 hours for Tactical Formation, Basic Fighter Maneuvers, and Air-to-Ground Fundamentals

## APPENDIX F

### COCKPIT SEATING CONFIGURATION

This appendix provides a discussion of possible seating arrangements for trainer aircraft. Seating configurations for use in concept designs were based on this discussion.

#### Side-by-Side Seating (Advantages).

1. It allows the IP access to all normal and emergency controls. This is important for instructional and emergency situations during the primary phase of training.
2. Permits direct physical contact in order to correct errors.
3. Allows direct observation of anticipated student errors (raise gear early, radio on wrong frequency, incomplete inflight checks, equipment not on, etc.).
4. Easier to direct a student's attention.
5. Can get to a "frozen" student
6. Facilitates in-cockpit instruction by gestures and actual demonstrations
7. Can cover instruments to enforce using outside references or partial panel recoveries.
8. Psychological well-being for basic student (IP is clearly visible and "near" student).

9. Forms good basis for follow-on to multi-engine aircraft (crew concept).
10. Eliminates "loss of intercom" problems.
11. Better forward visibility for both IP and student.
12. Eliminate tandem ejection sequence problems (do not want basic student inadvertently ejecting IP).
13. Requires only one of some, if not all, instruments (one radio control head, one set of engine instruments, etc.).

Side-by-Side Seating (Disadvantages).

1. Cross-Cockpit control problems (disorientation, T-37 air conditioner, etc)
2. Asymmetric references for traffic pattern work, formation, aerobatics.
3. Decreases student tendency to clear on IP side of aircraft
4. IP cannot always clear well on student's side.
5. Not consistent with follow-on high performance aircraft.
6. Some feeling of being in a multi-engine aircraft even when solo.
7. Greater tendency to rely on IP.
8. More difficult to accomplish hooded flight

9. Difficulty with rocket ejection seats (blast would burn other pilot - this may also require higher ejection minimums for a ballistic type ejection seat).

10. Large frontal area, therefore, some decrease in economy and performance.

Tandem Seating (Advantages).

1. Provides better over-the-side visibility (taxi, navigation, formation, acro, etc.).
2. More accurate sensing of vehicle accelerations (seat on centerline).
3. Symmetrical references for patterns/formation.
4. Similarity to high performance follow-on aircraft.
5. Better front seat visibility.
6. No cross-cockpit control problems.
7. Bag in back seat for fully hooded flight.
8. Things more "normal" when student solos.
9. Student picks up responsibility faster (by himself in the cockpit, less reliance on IP).

Tandem Seating(Disadvantages).

1. Limited forward visibility for back seat cupant (usually the IP).
2. Cannot see what student is doing or is about to do (significant in the basic phase).
3. Requires dual instrument displays and switches and may require some override controls.

4. Sequence ejection problems
5. May be more difficult to land from back seat.
6. Intercockpit communication problems with loss of intercom. "Who has the aircraft?"

Three-seat Configurations.

Consideration of a three-seat training aircraft poses the problem of how to position the three seats. Conclusions from a Northrup report, Future Undergraduate Pilot Training System Study, NOR 70-149, March 1971 (Ref. 16), indicate that in the dual track role, where the same aircraft is used for the primary phase and the basic (TTB) track of a dual track system, the seating arrangement should place two seats side-by-side in the front with the third seat in the rear. The third seat could be occupied by the Dynamic Observer in the primary training phase and the IP in the TTB basic track.

Use of the three-seat aircraft in a FAIR track would require that a single seat be positioned in front of two seats located side-by-side. The three-seat concept in a FAIR track does not appear warranted at this time without additional research.

Previous Study on Seating Configurations.

Research on trainer seating configuration is virtually non-existent. However, the Northrup FUPT study of 1971 did conduct an analysis of possible seating configurations for

trainer aircraft. The analysis did not use an analytical research approach, rather, as above, it was the result of "expert" opinions with regard to best seating configuration for instruction of the various training requirements of the mission.

The major advantage of side-by-side seating is that it allows for direct observation of the student. In an aircraft that is used only for primary training, this is desirable but it does not appear to be a limiting factor. Prior to the introduction of the T-37 in UPT, primary training was conducted in tandem seated aircraft.

When considering a single aircraft as the training vehicle for the entire UPT program, the advantages of tandem seating appear to outweigh the need to directly observe the student and would be the desirable seating configuration.

The following table was extracted from the Northrup FUPT study and provides an analysis of two-place primary trainer seating configurations versus training requirements.

TRAINING REQUIREMENTS VS SEATING CONFIGURATION  
TWO-PLACE PRIMARY TRAINER

<u>Training Requirement</u>	<u>Degree of Applicability</u>	<u>Analysis and Evaluation</u>	<u>Conclusion</u>
Ground Operations	Moderate	Side-by-side seating enables the instructor to closely monitor the student's cockpit activities, including engine starting procedure. Permits direct physical contact, if necessary, to correct student errors in subsystem operation. Provides the opportunity to anticipate student errors in the use of checklists.	Side-by-side seating
Pre-takeoff Taxi	Moderate	Side-by-side seating enables the instructor to directly monitor the student's cockpit activities during taxi to insure that proper procedures are learned and followed. Tandem seating provides better over-the-side visibility for viewing wing-tip clearance on both sides of the aircraft when operating solo.	Side-by side seating
Takeoff	High	Side-by-side seating provides the instructor with direct student observation so that he may anticipate student errors for rapid correction, which may avert the development of hazardous conditions in the critical close-to-the-ground maneuvering during takeoff.	Side-by-side seating

<u>Training Requirement</u>	<u>Degree of Applicability</u>	<u>Analysis and Evaluation</u>	<u>Conclusion</u>
Climb/ Level-off	Moderate	Side-by-side seating provides the instructor with direct student observation so that he may anticipate student errors for rapid correction, which may avert the development of hazardous conditions in the critical close-to-the-ground maneuvering during climbout. Tandem seating does provide more accurate sensing of vehicle accelerations by the pilot, but the magnitude is not considered sufficient to degrade climb and level off performance.	Side-by-side seating
Descent/ Approach	High	Side-by-side seating provides the instructor with direct student observation so that he may anticipate student errors for rapid correction, which may avert the development of hazardous conditions in the critical close-to-the-ground maneuvering of approach. Tandem seating does provide more accurate sensing of vehicle accelerations by the pilot, but the magnitude is not considered sufficient to degrade descent and approach performance.	Side-by-side Seating
Landing	High	Side-by-side seating provides the instructor with direct student observation so that he may anticipate student errors for rapid correction, which may avert the development of hazardous conditions in the landing roll-out.	Side-by-side seating

<u>Training Requirement</u>	<u>Degree of Applicability</u>	<u>Analysis and Evaluation</u>	<u>Conclusion</u>
Post-Landing Taxi	Moderate	Same as for pre-takeoff taxi.	Same as for pre-takeoff taxi
Basic Control Maneuvers	Slight	Tandem seating places the student pilot on the aircraft centerline which provides the best opportunity for sensing vehicle accelerations while performing various flight maneuvers. Although this is considered advantageous in aiding the novice pilot to develop appropriate flying skills, experience has shown that it does not prevent the student from satisfactorily acquiring these skills in a side-by-side seating configuration. This seating arrangement also makes it possible for the instructor to have direct visual and physical contact with the student for demonstration of correct cockpit actions and correction of errors. Tandem seating, on the other hand, provides the best over-the-side visibility for visual clearance of the training area before initiating maneuvers on solo flights.	Tandem seating preferred, side-by-side seating satisfactory
Precision Control	Slight	Same as above	Same as above
Stall Recognition & Recovery	Slight	Same as above	Same as above

<u>Training Requirement</u>	<u>Degree of Applicability</u>	<u>Analysis and Evaluation</u>	<u>Conclusion</u>
Aerobatics	Slight	Same as above	Same as above
Unusual Attitude Recovery Manuevers	Slight	Same as above	Same as above
Pilotage/Dead Reckoning	Moderate	Tandem seating provides the best combination of over-the-nose and over-the-side visibility for the student on navigation flights for the most efficient acquisition of VFR piloting skills.	Tandem seating
High/Low Altitude Navigation (Manual)	Moderate	Same as above	Tandem seating
Close Formation	Moderate	Tandem seating provides the best over-the-side visibility for the least disturbed view of the lead and other aircraft in close formation flying under most flight conditions and specially during solo flight. However, the direct student observation provided the instructor	Tandem seating preferred, side-by-side seating satisfactory

<u>Training Requirement</u>	Degree of <u>Applicability</u>	<u>Analysis and Evaluation</u>	<u>Conclusion</u>
Close Formation (cont'd)		through side-by-side seating enables the instructor to closely monitor the student's activities during the critical early learning periods of close formation flying.	

RECOMMENDATION

The primary trainer should be designed to accommodate side-by-side seating of the student and instructor to take advantage of the large benefits to be derived from direct visual and physical contact for observation and correction of procedural and flying errors that develop during the primary phase of flight training.

## APPENDIX G

### DYNAMIC OBSERVER CONCEPT

The term "Dynamic Observer" refers to the active involvement of a secondary trainee in a given training situation. Dynamic Observation (DO) is a training technique which can be applied both on the ground and in the air. When considering DO inflight, two possible applications exist: one is referred to as "team flying" in a two-seat aircraft, the other is as the third crew member in a three-seated aircraft.

Although little statistical research of DO has been conducted, a number of studies have considered the DO concept and provide some insight into probable DO advantages/disadvantages and applications. These studies--Northrop FUPT Study, 1971 (Ref. 16), FUPT MA, 1972 (Ref. 1), AFHRL-TR-72-61, 1973 (Ref. 17), Taylor & Striegel 1970 (Ref. 18), and ATC/DO analysis of DO questionnaires, 1974--all provide subject conclusions based on human logic regarding DO.

The FUPT Northrop Study and FUPT Mission Analysis conclude that DO is not cost effective when considered as a basis for purchase of a three-seat A/C solely for that purpose. The studies do indicate that the three-seat aircraft environment would provide for the best control of the DO situation. Some concern was expressed regarding the possible effect on the primary student.

in that having poor performance observed by a peer may be detrimental to the learning process. On the other hand, the student receiving instruction may have added incentive to perform better. Other possible disadvantages of DO considered the possibility of increased mission aborts due to airsickness, fatigue problems due to increased flying hours per day, and extended briefing/debriefing times. The advantages in the three-seat environment are increased student flight time and more efficient use of flight time. It does not appear that DO time would result in a significant reduction in time required at the controls.

The "team flying" concept has been applied to UPT several times in the past and is currently included in UPT. This concept pairs a junior student with an advanced student. Results are inconclusive as to training benefits derived through team flying, but it appears that some learning transfer does occur for both the Dynamic Observer and the student who is actually controlling the aircraft. The current application of the team flying concept consists of an average of two missions resulting in approximately two hours flying time. Field reports indicate both student and Instructor Pilot satisfaction with DO (team flying) and reflect the belief that some learning does occur. Perhaps the major advantage of team flying is that it allows students more exposure to the many variables involved in aerial flight.

Further, students feel that team flying increases their confidence and gives them a chance to view flying from the whole perspective since the DO is free from the normal cockpit duties associated with actually controlling the aircraft.

Available information, although not statistically determined, suggests that the DO concept offers training potential. Its use in a three-seat aircraft is much the same as when used under the team flying concept in two-seat aircraft.

Advantages.

1. Provides for more efficient use of air time (i.e., filling a previously empty seat).
2. Increases student exposure to flight situations.
3. Allows student to assess the conduct of flight without concentration on the actual control of the aircraft.
4. Appears to increase performance of the student pilot being observed.
5. Used in the team flight concept, it does not require an aircraft designed with a third seat.
6. In the team flight concept, it eliminates student dependencies on the instructor.
7. Allows for increased confidence and exercise of crew coordination and judgment in the student pilot.

8. Enhances flying safety with regard to clearing.
9. Allows the DO to learn basic perceptual and auditory sensations of flight (i.e., how it feels and sounds to ride through the maneuvers).
10. Allows for effective learning of procedures.

Disadvantages.

1. In the three-seat environment, a new aircraft must be procured.
2. May impose additional psychological loads on the student who is flying the aircraft, particularly if his performance is poor.
3. Possibility of increased mission aborts due to airsickness (i.e., riding through maneuvers when not actually controlling the aircraft can cause nausea even in experienced pilots).
4. Scheduling constraints must be closely monitored to assure that the student fatigue factor does not increase.
5. Increased briefing/debriefing requirements.
6. Does not appear to reduce flying time required in actually controlling the aircraft.
7. The program requires positive and assured control of student air discipline.

Although DO is a viable concept which should be seriously considered for retention in Future UPT, the

additional benefits derived from DO do not justify designing an aircraft to accomplish that purpose only. Team flying appears to offer positive training benefits, enhances student morale, and can be actively pursued in a two-seat training aircraft.

## APPENDIX H

### AIRCRAFT PRODUCTION AND PHASE-IN SCHEDULES

The tables in this appendix detail aircraft production rates and the phase-in of flying hours of the various FUPT alternatives examined in this study. Although numerous alternative aircraft production schedules are possible which may enhance overall cost effectiveness, the information presented here was used for cost comparisons.

Table 22, Aircraft Production Schedule, assumes a production rate of 20 aircraft per month. A cumulative aircraft production rate is depicted in the second column. Using a 60 hr/month utilization rate for an 11½ month training year, monthly flying hours which can be accumulated on the new aircraft are depicted in column 3. Column 4 is an accumulation of these hours on an annual basis. Thus, by the end of the first year a total of 89,700 flying hours are available in the new aircraft, 255,300 at the end of the second year, etc.

Tables 23 through 26 depict the phase-in of the new aircraft by flying hours, using the aircraft production schedule in Table 22 and pilot production rates from Table 4 (FY 82 on). Also shown, in the far right column, is the total number of new aircraft required to support the flying hour schedule at the end of phase-in. The

number of additional aircraft required due to accident attrition is shown in parentheses. ACE requirements are shown separately, as existing T-37/T-38 aircraft resources could possibly be used to support this program. In Table 26, a concurrent production of XT-1 and XT-3 aircraft was used for purposes of this study.

Table 22

Aircraft Production Schedule

<u>Month</u>	<u>Cumulative Production</u>	<u>Monthly Hours</u>	<u>Cumulative Hrs (Annual)</u>
0	0	0	0
1	20	1150	1150
2	40	2300	3450
3	60	3450	6900
4	80	4600	11500
5	100	5750	17250
6	120	6900	24150
7	140	8050	32200
8	160	9200	41400
9	180	10350	51750
10	200	11500	63250
11	220	12650	75900
12	240	13800	89700
-----			
13	260	14,950	14,950
14	280	16,100	31,050
15	300	17,250	48,300
16	320	18,400	66,700
17	340	19,550	86,250
18	360	20,700	106,950

Table 22 (contd)

<u>Month</u>	<u>Cumulative Production</u>	<u>Monthly Hours</u>	<u>Cumulative Hrs (Annual)</u>
19	380	21,850	128,800
20	400	23,000	151,800
21	420	24,150	175,950
22	440	25,300	201,250
23	460	26,450	227,700
24	480	27,600	255,300
-----			
25	500	28,750	28,750
26	520	29,900	58,650
27	540	31,050	89,700
28	560	32,200	121,900
29	580	33,350	155,250
30	600	34,500	189,750
31	620	35,650	225,400
32	640	36,800	262,200
33	660	37,950	300,150
34	680	39,100	339,250
35	700	40,250	379,500
36	720	41,400	420,900
-----			
37	740	42,550	42,550
38	760	43,700	86,250
39	780	44,850	131,000

Table 22 (contd)

<u>Month</u>	<u>Cumulative Production</u>	<u>Monthly Hours</u>	<u>Cumulative Hrs (Annual)</u>
40	800	46,000	177,100
41	820	47,150	224,250
42	840	48,300	272,550
43	860	49,450	322,000
44	880	50,600	372,600
45	900	51,750	424,350
46	920	52,900	477,250
47	940	54,050	581,300
48	960	55,200	586,500
-----			
49	980	56,350	56,350
50	1000	57,500	113,850
51	1020	58,650	172,500
52	1040	59,800	232,300

Table 23  
 Flying Hour Phase-In Schedule (XT-1/T-38)

Program	Year 1		Year 2		Year 3		A/C Req'd (+ Attrition)
	XT-1	T-37	XT-1	T-37	XT-1	T-37	
UPT	203,423	141,242	226,531	0	226,531	0	317
PIT	20,456	0	20,456	0	20,456	0	29
Med Off	260	260	260	0	260	0	1
FWQ	1,923	1,923	1,923	0	1,923	0	3
SAPT	53,550	53,550	6,130	47,420	53,550	0	75
Sub-Total	<u>279,612</u>	<u>196,975</u>	<u>225,300</u>	<u>47,420</u>	<u>302,720</u>	<u>0</u>	<u>425 (+61)</u>
ACE	30,588	30,588	0	30,588	30,588	0	43
	<u>310,200</u>	<u>227,563</u>	<u>255,300</u>	<u>78,008</u>	<u>333,308</u>	<u>0</u>	<u>468 (+67)</u>
	T-38	T-38	T-38	T-38	T-38	T-38	
UPT	257,410	253,003	242,994	242,994	242,994	242,994	
PIT	23,578	23,578	23,578	23,578	23,578	23,578	
IPIS	5,033	5,033	5,033	5,033	5,033	5,033	
FWQ	3,898	3,898	3,898	3,898	3,898	3,898	
SAPT	29,686	29,686	29,686	29,686	29,686	29,686	
Sub-Total	<u>319,605</u>	<u>315,198</u>	<u>305,189</u>	<u>305,189</u>	<u>305,189</u>	<u>305,189</u>	
ACE	35,808	35,808	35,808	35,808	35,808	35,808	
	<u>355,413</u>	<u>351,006</u>	<u>340,997</u>	<u>340,997</u>	<u>340,997</u>	<u>340,997</u>	

Table 24

Flying Hour Phase-In Schedule (XT-2)

Program	Year 0			Year 1			Year 2		
	T-37	T-38	XT-2	T-37	T-38	XT-2	T-37	T-38	XT-2
UPT	203,423	257,410	163,973	207,490	81,876	91,141	115,329	233,033	
PIT	20,456	23,578	16,821	19,389	7,824	10,112	11,655	22,267	
Med Off	260		260			260			
IPIS		5,033		5,033			5,033		
FWQ	1,923	3,898	1,923	3,898		1,923	3,898		
SAPT	53,550	29,686	53,550	29,686		53,550	29,686		
Sub-Total	279,612	319,605	236,527	265,496	89,700	156,986	165,601	255,300	
ACE	30,588	35,808	30,588	35,808		30,588	35,808		
	310,200	355,413	267,115	301,304	89,700	187,574	201,409	255,300	

Table 24 (contd)  
Flying Hour Phase-In Schedule (XT-2)

Program	Year 3		Year 4		Year 5 XT-2	A/C Reqd (+ Attrition)
	T-37	T-38	T-37	T-38		
UPT	21,838	27,634	376,866	422,190	422,190	591
PIT		44,034		44,034	44,034	62
Med Off	260			260	260	1
IPIS		5,033		5,033	5,033	7
FWQ	1,923	3,898		5,821	5,821	8
SAPT	53,550	29,686		54,432	54,432	77
Sub-Total	77,571	66,251	420,900	531,770	531,770	745 (+160)
ACE	30,588	35,808		54,730	66,396	93
	108,159	102,059	420,900	586,500	598,166	838 (+179)



Table 25 (contd)  
Flying Hour Phase-In Schedule (XT-3/XT-3/T-38)

Program	Year 3		Year 4	A/C Regd
	T-37	XT-3	XT-3	(+ Attrition)
UPT		337,932	337,932	473
PIT		34,603	34,603	48
MO		260	260	1
FWQ		4,262	4,262	6
SAPT	13,666	43,843	58,866	83
Sub-Total	13,666	420,900	435,923	611 (+87)
ACE	30,588		30,588	43
	44,254	420,900	466,511	654 (+93)
	T-38 (26TR)	T-38 (30TR)	T-38 (26TR)	T-38 (30TR)
UPT	97,979	112,618	97,979	112,618
PIT	9,431	9,431	9,431	9,431
IPIS	5,033	5,033	5,033	5,033
FWQ	1,559	1,559	1,559	1,559
SAPT	31,549	31,549	31,549	31,549
Sub-Total	145,551	160,190	145,551	160,190
ACE	35,808	35,808	35,808	35,808
	181,359	195,998	181,359	195,998

Note: 30TR reflects additional hours needed to add a tactical phase

Table 26  
 Flying Hour Phase-In Schedule (XT-1/XT-3/T-38)

Program	Year 0			Year 1			Year 2		
	T-37	XT-1	XT-3	T-37	XT-1	XT-3	T-37	XT-1	XT-3
UPT	203,423	141,242	75,553	69,244	226,531	111,401	226,531	226,531	111,401
PIT	20,456	20,456	14,147	20,456	20,456	14,147	20,456	20,456	14,147
MO	260	260			260			260	
FWQ	1,923	1,923		1,923	1,923		1,923	1,923	2,339
SAPT	53,550	53,550		53,550	6,130		6,130	6,130	5,316
Sub-Total	279,612	196,975	89,700	89,700	255,300	133,203	255,300	255,300	133,203
ACE	30,588	30,588		30,588			30,588		
	310,200	227,563	89,700	89,700	255,300	133,203	255,300	255,300	133,203
	T-38	T-38	T-38	T-38	T-38	T-38	T-38	T-38	T-38
	(26 TR)	(26 TR)	(30 TR)	(26 TR)	(30 TR)	(30 TR)	(26 TR)	(30 TR)	(30 TR)
UPT	257,410	116,913	131,552	131,552	97,979	112,618	97,979	112,618	97,979
PIT	23,578	23,578	23,578	23,578	9,431	9,431	9,431	9,431	9,431
IPIS	5,033	5,033	5,033	5,033	5,033	5,033	5,033	5,033	5,033
FWQ	3,898	3,898	3,898	3,898	1,559	1,559	1,559	1,559	1,559
SAPT	29,686	29,686	29,686	29,686	31,549	31,549	31,549	31,549	31,549
Sub-Total	319,605	179,108	193,747	193,747	145,551	160,190	145,551	160,190	145,551
ACE	35,808	35,808	35,808	35,808	35,808	35,808	35,808	35,808	35,808
	355,413	214,916	229,555	229,555	181,359	195,998	181,359	195,998	181,359



APPENDIX I

A COST ANALYSIS FOR THE  
FUTURE UNDERGRADUATE PILOT TRAINING (FUPT) AIRCRAFT

Prepared By:  
HQ, Air Training Command  
DCS/Comptroller  
Directorate of Cost & Management Analysis  
Randolph Air Force Base, TX 78148

April 1977

OBJECTIVE: The objective of this analysis is to provide management with indicators of the relative cost of undergraduate pilot training (UPT) system options. Specifically, three options are examined; (1) replacement for the T37 aircraft, (2) a single (all through) aircraft replacement for the T37 and T38, and (3) two aircraft replacement of the T37 and T38 (dual track training). Also, as an alternative to this option, a new aircraft/T38 dual track is considered. Each of the options is finitely described in the Future Undergraduate Pilot Training (FUPT) Aircraft Study of which this analysis is to become an integral part.

METHODOLOGY & PROCEDURES: Procedures were adopted which would allow the development of a rank ordered costing without the constraints of a formal Life Cycle Costing (LCC) or a definitive comparative analysis. That is, major areas of cost which are sensitive to system design and training concept are used whereas those which are driven primarily by the actual training process are excluded. The constant used as a basis for the cost compilation is aircraft flying hours. The use of this unit of measure is desirable in that a number of options, and alternatives within each option, can be assessed without concern for a precise curriculum structure and student load composition. This procedure will not result in the development of a total systems cost. A Life Cycle Costing (LCC) will follow once the training concept, which will dictate system design, is decided upon. In addition, a typical unit cost of producing an USAF UPT graduate under each alternative has been compiled. These costs, as opposed to the rank ordered cost, consist of direct and in-direct training elements and exclude the sunk costs associated with acquiring the new system. A listing of cost elements included in the rank ordered costing and the typical unit costing are provided at page I-10.

The program life for each of the options is 23 years (1984 through 2006). This time period spans the life of whatever system is selected except that the T38 would need to be replaced in the mid-1990s under Option I. The low probability of accurately projecting aircraft acquisition cost 20 years hence is recognized; however, for the purpose of this analysis we have used as an estimate those data provided by ASD for the XT2 (single, all-through aircraft).

The rank ordered cost data are presented in constant (FY77), current, and discounted dollars. Current dollars were derived by applying a rate of increase of seven percent, compounded annually. Discounting as it is used in this analysis places a value upon the loss of opportunity to private investment, and the yield upon that investment, when private investment is displaced by government expenditure.

The typical unit cost data are presented in constant FY77 dollars.

DATA & FACTORS SOURCES: Phasing, aircraft buy levels, simulator modification cost, and maintenance and materials factors were provided by the FUPT Study Office (ATC/XPO). RTD&E and aircraft unit costs were provided by ASD/XRP. Aircraft residual values are based upon the number of aircraft becoming

excess within each option as determined by ATC/XPO with a selling price as determined by the AF Pricing Board except that the residual value of the T38 replacement in Option I is projected to be half of its procurement cost. Elemental cost factors (personnel, AVPOL, base operating support (BOS) non-personnel, personal equipment, curriculum TDY etc.), discount rates, and inflation factors were derived from ATC experience and/or taken from Air Force directives as appropriate for their respective use.

RESULTS OF THE ANALYSIS: As an aid to the reader a brief description of each alternative is provided:

Option I - Generalized pilot production program. Replacement of the T37. Replacement of the T38 in a mid-1990s time frame is a requirement of this option. The T37 replacement is designated "XT1".

Option II - Generalized pilot production program. Replacement of the T37 and T38 for a single all-through aircraft. The replacement aircraft is designated "XT2".

Option III - Alternative A - Dual track pilot production program. Replacement of the T37 aircraft. The replacement aircraft is designated "XT3". The XT3 will be flown by all students in the primary phase. TTB students will continue in the XT3 for their basic phase while FAIR students transition to the T38 for their basic phase.

Option III - Alternative B - Dual track pilot production program. Replacement of the T37 with the XT1 and the XT3. XT1 flown by all students in the basic phase. Transition to XT3 for TTB track and to T38 for FAIR track.

Table I is a recapitulation of totals for each of the alternatives. Ranking is in ascending order, i.e., "(1)" least costly, "(4)" most costly. All dollars are in millions. Figures represent one year of uniform cost, except that the typical unit cost is that of producing an USAF pilot. "With residual" reflects the reduction of cost by the value of excess aircraft, "without residual" takes no credit for value of excess aircraft. In the case of typical unit cost, value of excess aircraft is not a consideration.

The following observations are provided relative to the Table I data:

a. The sale and/or re-use value of excess aircraft is not a certainty -- thus the costs "without residual" value have a higher degree of probability of occurrence than those "with residual" value.

b. All new aircraft under study have a considerably lower fuel consumption rate than the T38. Except for Option II, the T38 remains in the training system to some degree. An infinite number of cost excursions could be made based upon an individual's thinking on future energy availability/policy. The multiplicity of guesses and their uncertainty dictates their exclusion from this analysis; however, the following FY77 per hour fuel cost factors, as used in the analysis, highlight the significance of this element: T38-\$176.40, XT1-\$21.61, XT2-\$55.57, XT3-\$47.63.

TABLE I

	RANK ORDERED COST			TYPICAL UNIT COST
	<u>CONSTANT \$</u>	<u>CURRENT \$</u>	<u>DISCOUNTED \$</u>	<u>FY77\$</u>
OPTION I				
With Residual	222.303(3)	683.843(3)	271.666(3)	
W/O Residual	237.355(4)	781.062(4)	285.210(4)	.102(4)
OPTION II				
With Residual	211.930(2)	667.667(1)	264.071(2)	
W/O Residual	220.292(2)	685.822(2)	271.039(2)	.083(2)
OPTION III - Alt A				
With Residual	226.233(4)	746.879(4)	276.937(4)	
W/O Residual	228.083(3)	750.641(3)	279.513(3)	.086(3)
OPTION III - Alt B				
With Residual	205.214(1)	668.842(2)	252.305(1)	
W/O Residual	207.139(1)	672.760(1)	254.983(1)	.080(1)
(RANK)				

c. Option III - Alternative B brings two new aircraft into the system. While maintenance personnel training costs are treated as a wash item in the analysis, it is recognized that initial training will be greater for the two new aircraft. This is an one-time cost, which based upon experience with a more complex system would not alter the present rankings.

d. Option II - Requires a high volume aircraft buy in an early time frame of the program. An aircraft buy of 902 XT2s will require the expenditure of \$1.881 billion in current year dollars in 1984-1986. These investment costs are off-set by a comparatively low recurring operating cost which is in-turn influenced by absence of the T38 from the system.

e. Option II and Option III - Alternative B offer distinct economic advantages over the other options; however, Option III B is second high in operating cost and is therefore more susceptible to inflationary influences downstream than are Options I and II.

f. Option I, which uses the lowest operating cost aircraft under study (XT1), loses this advantage by continued use of the T38 until the mid 1990s. This condition is reflected in both the rank ordered and typical unit cost.

In summary, the sale and/or re-use of excess aircraft cannot be viewed as a certainty. Instability in energy availability and policy impact upon the economic aspects of selecting a FUPT system---the T38 is especially critical in this respect. Bringing two new aircraft into the system will involve expenditure of additional funds for initial training. Selection of the all-through single aircraft system will require high procurement appropriations in the mid 1980s. Options II and III B have an economic advantage over the remaining options; however, Option III B is relatively high in operating cost. Option I uses the XT1 which has the lowest operating cost of all aircraft under study; however, when coupled with the T38 it is high in both rank order and typical unit cost.

Details of the rank ordered costing are provided on pages I-6 through I-9.



FUTURE INTERMEDIATE PILOT TRAINING (FIPT) AIRCRAFT  
 OPTION II - STRAIGHT THROUGH SINGLE AIRCRAFT  
 23 YEAR PROJECT LIFE  
 (MILLIONS OF DOLLARS)

YEAR	INVESTMENT AIRCRAFT		RECURRING OPERATIONS				YR	VALUE	SUBTOTAL	'77 CONSTANT DOLLARS	INFLATOR	CURRENT DOLLARS	DISCOUNT FACTOR	DISCOUNTED DOLLARS
	SIM. MOD.	UNITS	HOURS	VALUE	HOURS	VALUE								
1964	\$223,399	5,000	279,612	\$ 72,140	313,405	\$161,081		\$ 233,221	\$ 461,620	1.6868	\$ 741,259	.954	\$ 707,171	
65	17,440	300	279,612	72,140	313,405	161,081		233,221	541,073	1.7182	1,015,562	.907	880,510	
66	20,330	301	194,956	40,504	155,456	83,463	89,720	220,124	581,911	1.7595	1,069,643	.860	943,036	
67	23,260	301	154,556	40,504	114,052	66,261	255,300	195,960	560,732	1.9672	1,023,072	.813	806,591	
68			77,571	20,015	57,556	33,391	420,900	175,080	73,286	2.1849	877,154	.767	660,591	
69							531,770	149,960	56,469	2.2828	757,154	.720	552,263	
70								149,960	149,960	2.4784	561,388	.680	404,437	
71								149,960	149,960	2.7581	413,755	.649	289,030	
72									149,960	3.0378	266,687	.618	189,030	
73									149,960	3.3188	184,121	.587	124,823	
74									149,960	3.5990	124,712	.556	80,258	
75									149,960	3.8792	80,865	.525	50,119	
76									149,960	4.1594	50,935	.494	30,000	
77									149,960	4.4396	31,305	.463	16,000	
78									149,960	4.7198	16,633	.432	8,000	
79									149,960	5.0000	8,000	.401	4,000	
80									149,960	5.2802	4,000	.370	2,000	
81									149,960	5.5604	2,000	.339	1,000	
82									149,960	5.8406	1,000	.308	500	
83									149,960	6.1208	500	.277	250	
84									149,960	6.4010	250	.246	125	
85									149,960	6.6812	125	.215	62.5	
86									149,960	6.9614	62.5	.184	31.25	
87									149,960	7.2416	31.25	.153	15.625	
88									149,960	7.5218	15.625	.122	7.8125	
89									149,960	7.8020	7.8125	.091	3.90625	
90									149,960	8.0822	3.90625	.060	1.953125	
91									149,960	8.3624	1.953125	.029	0.9765625	
92									149,960	8.6426	0.9765625	.014	0.48828125	
93									149,960	8.9228	0.48828125	.007	0.244140625	
94									149,960	9.2030	0.244140625	.003	0.1220703125	
95									149,960	9.4832	0.1220703125	.001	0.06103515625	
96									149,960	9.7634	0.06103515625	.000	0.030517578125	
97									149,960	10.0436	0.030517578125	.000	0.0152587890625	
98									149,960	10.3238	0.0152587890625	.000	0.00762939453125	
99									149,960	10.6040	0.00762939453125	.000	0.003814697265625	
2001									149,960	10.8842	0.003814697265625	.000	0.0019073486328125	
02									149,960	11.1644	0.0019073486328125	.000	0.00095367431640625	
03									149,960	11.4446	0.00095367431640625	.000	0.000476837158203125	
04									149,960	11.7248	0.000476837158203125	.000	0.0002384185791015625	
05									149,960	12.0050	0.0002384185791015625	.000	0.00011920928955078125	
06									149,960	12.2852	0.00011920928955078125	.000	0.000059604644775390625	
PROJECT TOTAL	\$223,399	\$67,790		\$265,819		\$572,826		\$3,753,909	\$4,874,401		\$15,356,343		\$6,073,624	
BANK DETERMINANT - UNIFORM ANNUAL FACTOR														
BANK DETERMINANT - UNIFORM ANNUAL FACTOR (Without Residual Value)														
(Credits) Residual Value of Earnest Act														

FUTURE UNDERGRADUATE PILOT TRAINING (FUPT) AIRCRAFT  
 OPTION 111A - ONE NEW AIRCRAFT DUAL TRACK  
 23 YEAR PROJECT LIFE  
 (MILLIONS OF DOLLARS)

YEAR	INVESTMENT		AIRCRAFT		RECURRING OPERATIONS		T37		T38		T39		T40		777 CONSTANT DOLLARS	INFLATION	CURRENT DOLLARS	DISCOUNT FACTOR	DISCOUNTED DOLLARS
	POYAE	SW MOD	UNITS	VALUE	HOURS	VALUE	HOURS	VALUE	HOURS	VALUE	HOURS	VALUE	HOURS	VALUE					
1964	\$163.165														\$ 401.496	1.6058	\$ 644.722	954	\$ 615.065
65		\$ 110		\$ 72.140	273.412	\$ 72.140	312.696	161.001	312.696	312.696	312.696	312.696	312.696	312.696	\$ 420.454	1.7082	1,066.062	857	924.276
66		350		50.920	542.015	50.920	612.138	161.001	612.138	612.138	612.138	612.138	612.138	612.138	\$ 538.522	1.8385	1,173.923	795	965.051
67		39,700		14.374	457.333	14.374	50,576	20,259	50,576	50,576	50,576	50,576	50,576	50,576	\$ 204.432	1.9672	1,406.211	717	291.253
68				3,526	1,346	1,346	1,346	1,346	1,346	1,346	1,346	1,346	1,346	1,346	\$ 156.290	2.1045	328.975	652	214.482
69															\$ 176.672	2.2522	397.901	578	258.960
70															\$ 176.672	2.4099	425.566	494	277.820
71															\$ 176.672	2.5676	455.566	448	292.722
72															\$ 176.672	2.7253	487.456	445	216.918
73															\$ 176.672	2.8830	521.571	405	211.236
74															\$ 176.672	3.0407	558.072	368	216.410
75															\$ 176.672	3.1984	597.151	324	194.241
76															\$ 176.672	3.3561	638.668	276	168.692
77															\$ 176.672	3.5138	683.668	228	138.614
78															\$ 176.672	3.6715	731.528	181	103.614
79															\$ 176.672	3.8292	782.728	135	68.614
80															\$ 176.672	3.9869	837.531	90	34.614
81															\$ 176.672	4.1446	896.151	45	0.614
82															\$ 176.672	4.3023	958.082	0	0.000
83															\$ 176.672	4.4600	1,023.082	0	0.000
84															\$ 176.672	4.6177	1,091.822	0	0.000
85															\$ 176.672	4.7754	1,164.674	0	0.000
86															\$ 176.672	4.9331	1,242.526	0	0.000
87															\$ 176.672	5.0908	1,325.378	0	0.000
88															\$ 176.672	5.2485	1,413.230	0	0.000
89															\$ 176.672	5.4062	1,506.082	0	0.000
90															\$ 176.672	5.5639	1,603.934	0	0.000
91															\$ 176.672	5.7216	1,706.786	0	0.000
92															\$ 176.672	5.8793	1,814.638	0	0.000
93															\$ 176.672	6.0370	1,927.490	0	0.000
94															\$ 176.672	6.1947	2,045.342	0	0.000
95															\$ 176.672	6.3524	2,168.194	0	0.000
96															\$ 176.672	6.5101	2,296.046	0	0.000
97															\$ 176.672	6.6678	2,428.898	0	0.000
98															\$ 176.672	6.8255	2,566.750	0	0.000
99															\$ 176.672	6.9832	2,709.602	0	0.000
00															\$ 176.672	7.1409	2,857.454	0	0.000
01															\$ 176.672	7.2986	3,010.306	0	0.000
02															\$ 176.672	7.4563	3,168.158	0	0.000
03															\$ 176.672	7.6140	3,330.010	0	0.000
04															\$ 176.672	7.7717	3,495.862	0	0.000
05															\$ 176.672	7.9294	3,665.714	0	0.000
06															\$ 176.672	8.0871	3,839.566	0	0.000
PROJECT TOTAL	\$163.165	\$56.160		\$701.208	\$313.095	\$701.208	\$313.095	\$701.208	\$313.095	\$701.208	\$313.095	\$701.208	\$313.095	\$701.208	\$5,203.350	7.1143	\$17,178.216		\$6,969.543
BANK DETERMINANT - UNIFORM ANNUAL FACTOR															\$ 226.233		\$ 746.879		\$ 276.937
BANK DETERMINANT - UNIFORM ANNUAL FACTOR (Without Residual Value)															\$ 228.083		\$ 750.641		\$ 279.513

(Credit) Residual Value of Excess Acft

FUTURE UNDERGRADUATE PILOT TRAINING (FUT) AIRCRAFT  
 OPTION IIIB - TWO NEW AIRCRAFT DUAL TRACK  
 23 YEAR PROJECT LIFE  
 (MILLIONS OF DOLLARS)

YEAR	INVESTMENT AIRCRAFT		REPAIRS OPERATIONS		F-37		F-38		REPAIRS OPERATIONS		F-35		SUBTOTAL	7% CONSTANT DOLLARS	INFLATION	COMPONENT DOLLARS	DISCOUNT FACTOR	DISCOUNTED DOLLARS	
	PERIOD	UNIT	HOURS	VALUE	HOURS	VALUE	HOURS	VALUE	HOURS	VALUE	HOURS	VALUE							
1984	\$23.888	\$10.110	279,612	\$ 22,140	319,655	\$ 61,081							\$ 233,221	\$ 497,216	1,605	\$ 788,459	.854	\$ 671,701	
1985		350	527,582	72,452	374,505	61,051							233,221	546,582	1,712	1,065,047	.867	888,716	
1986		350	527,582	72,452	374,505	61,051							233,221	546,582	1,825	1,065,047	.880	933,922	
1987			(22,056)	47,420	145,551	73,358	15,818	88,700	21,239	167,889			157,298	138,242	2,142	283,671	.717	195,222	
1988			(22,056)	47,420	145,551	73,358	15,818	88,700	21,239	167,889			157,298	138,242	2,255	283,671	.730	209,752	
1989					145,551	73,358	52,371	133,203	31,569	157,298			157,298	137,298	2,368	384,267	.743	283,671	
1990					145,551	73,358	52,371	133,203	31,569	157,298			157,298	137,298	2,481	379,072	.756	283,671	
1991															2,594	405,609	.769	308,443	
1992															2,707	434,001	.782	337,130	
1993															2,820	464,375	.795	366,072	
1994															2,933	494,749	.808	395,102	
1995															3,046	525,123	.821	424,133	
1996															3,159	555,497	.834	453,164	
1997															3,272	585,871	.847	482,195	
1998															3,385	616,245	.860	511,226	
1999															3,498	646,619	.873	540,257	
2000															3,611	676,993	.886	569,288	
2001															3,724	707,367	.899	598,319	
2002															3,837	737,741	.912	627,350	
2003															3,950	768,115	.925	656,381	
2004															4,063	798,489	.938	685,412	
2005															4,176	828,863	.951	714,443	
2006															4,289	859,237	.964	743,474	
2007															4,402	889,611	.977	772,505	
2008															4,515	920,000	.990	801,536	
2009															4,628	950,374	.100	830,567	
2010	\$23.888	\$67.839	\$610,897	\$207,334	\$1,879,592	\$1,054,734	\$2,583,639	\$1,371,203	\$1,572,988	\$3,794,000	\$4,719,920	\$207,139	\$4,927,058	\$5,803,007	7,143	\$15,383,367	.117	\$13,916	
TOTAL																			

PAY DETERMINANT - UNIFORM ANNUAL FACTOR

PAY DETERMINANT - UNIFORM ANNUAL FACTOR (Without Residual Value)

\* Includes one F-35 Complex for Band 10n - Total Cost \$5,549.

(Credits) Residual Value of Excess Aircraft

COST ELEMENT APPLICATIONS

<u>ELEMENTS OF COST</u>	<u>RANK ORDERED</u>	<u>TYPICAL UNIT</u>
1. RDT&E	X	
2. Aircraft Acquisition <sup>1</sup>	X	
3. Aircraft Sales (Credit)	X	
4. Simulator Modification	X	
5. Simulator Acquisition	X	
6. Maintenance Labor	X	X
7. Maintenance Materials	X	X
8. Replenishment Spares	X	X
9. Depot Maintenance	X	X
10. AVPOL	X	X
11. BOS Personnel	X <sup>2</sup>	X
12. BOS Non-Personnel	X <sup>2</sup>	X
13. Instructor Pilots		X
14. Support Officers		X
15. Personal Equipment		X
16. Curriculum TDY		X
17. Student PCS		X
18. Operations Support		X
19. Student Pay		X

<sup>1</sup> Includes spare engines

<sup>2</sup> Limited to BOS Personnel and Non-Personnel associated with the maintenance labor force.

## APPENDIX J

### AIRCRAFT AND SIMULATOR COST ESTIMATES

This appendix contains the cost estimates supplied by ASD for aircraft and simulator RDT&E and production. Aircraft costs were estimated using the Rand DAPCA III cost estimating model. Aircraft costs are shown in FY 76 dollars, and were converted to FY 77 dollars by multiplying by a factor of 1.0598. Simulator modification costs are given in FY 77 dollars.

Aircraft costs are provided as cumulative average costs for various production levels. The unit cost is used to interpolate for production levels other than depicted. For example, to compute the cost of procuring 625 aircraft, one would use the "cum total with fee" for 600 aircraft, then add the cost of 25 aircraft at the "unit" cost at the 600 aircraft buy level.

BASE COST INVT FOR AT-1 TRAINING (4401) - 15 NOV 76

TOTAL AIRCRAFT COSTS  
(MILLIONS OF DOLLARS)

(CUMULATIVE PROGRESSMENT = 1 ; AIRCRAFT PROGRESSMENT = 0)

DEVELOPMENT

AIRCRAFTS 47.0065      ENGINES 27.7202      AIRCRAFTS 85.6012

PRODUCTION

(CUMULATIVE AVERAGE - - - - - ; CUMULATIVE TOTALS - - - - -)

AIRCRAFT QUANTITY	ENGINE QUANTITY	AIRCRAFTS	ENGINES	AIRCRAFTS	TOTAL WITH FEE	CUM TOTAL WITH FEE	CUM TOTAL WITH FEE	(SPARE) (ENGINES)
50	125	1.0534	.3116	.0542	1.4894	71.9588	157.3730	3.8947
100	250	.7935	.2402	.0619	1.0945	109.4592	194.0604	5.9811
200	500	.5861	.1870	.0532	.8232	155.2584	250.3235	9.1521
300	750	.4327	.1387	.0394	.7094	189.8104	275.4115	10.9167
400	1000	.3445	.1078	.0353	.6288	212.8123	298.4135	11.7965
500	1250	.2855	.0874	.0315	.5579	255.5050	341.1072	14.1803
600	1500	.2475	.0734	.0279	.5025	332.3199	417.3211	18.5065
800	2000	.1881	.0542	.0237	.4529	401.9779	487.5730	22.4752
1000	2500	.1491	.0417	.0202	.4231	465.8451	532.5433	26.2147
1200	3000	.1197	.0329	.0165	.3931	295.0442	380.5434	16.4009

UNIT

50	125	.5370	.1374	.0502	.9454
100	250	.4459	.1467	.0581	.6587
200	500	.3415	.1175	.0554	.5105
300	750	.2940	.1055	.0543	.4743
400	1000	.2531	.0937	.0538	.4475
500	1250	.2200	.0817	.0523	.4204
600	1500	.1924	.0704	.0511	.4004
800	2000	.1468	.0528	.0501	.3852
1000	2500	.1133	.0402	.0492	.3755
1200	3000	.0863	.0318	.0481	.3671

RIP

DAPCA COST INPUTS FOR XT-2 TRAINER (X-400) ENGINE 15 NOV 76

TOTAL AIRCRAFT COSTS  
(MILLIONS OF DOLLARS)

(ENGINE ORDER PROCUREMENT = 3 ; AVIONICS ORDER PROCUREMENT = 0)

DEVELOPMENT

AIRFRAMES 109.5776 ENGINES 109.1712 AVIONICS .8455 TOTAL WITH FEE 210.7943

PRODUCTION

AIRFRAME QUANTITY	ENGINE QUANTITY	AIRFRAMES	ENGINES	AVIONICS	TOTAL WITH FEE	CUM TOTAL WITH FEE	CUM TOTAL WITH RATE	(SHARE) (ENGINES)
50	125	2.7129	.5994	.0711	2.9735	148.5733	359.4579	7.3678
100	250	4.7261	.9385	.0594	2.2912	228.4196	438.3139	12.2159
200	500	8.2974	1.7359	.0555	1.7581	353.8235	584.5178	20.2953
250	625	1.1837	.2832	.0545	1.5344	408.6079	619.4022	23.9479
300	750	1.1079	.2559	.0535	1.5336	450.0933	570.8879	27.4406
400	1000	.3945	.7469	.0525	1.3399	555.9571	766.7515	34.0819
600	1500	.3445	.7597	.0515	1.2151	729.0729	939.8553	45.4543
800	2000	.7392	.2932	.0507	1.1081	885.4734	1097.9577	58.0455
1000	2500	.5387	.2764	.0507	1.0335	1031.4727	1244.3370	69.1095
500	1250	.9092	.7271	.0511	1.2900	544.9969	856.7983	40.83903

UNIT

50	125	1.3201	.4379	.0575	1.8215			
100	250	1.0075	.3053	.0546	1.4282			
200	500	.7754	.2300	.0517	1.1368			
250	625	.7149	.2453	.0507	1.0502			
300	750	.6591	.2742	.0501	1.0028			
400	1000	.6062	.2837	.0507	.9308			
600	1500	.5252	.2885	.0503	.8307			
800	2000	.4767	.2959	.0504	.7581			
1000	2500	.4497	.2970	.0504	.7147			
500	1250	.5591	.2471	.0574	.8575			

DARPA COST INPUTS FOR X-35 TRAINER (X-35) ENGINE 15 NOV 76

TOTAL AIRCRAFT COSTS  
(MILLIONS OF DOLLARS)

(ENGINE PRIOR PROCUREMENT = 0 ; AVIONICS PRIOR PROCUREMENT = 0)

AIRFRAMES 101.5634 ENGINES 54.1507 AVIONICS 1.1471 TOTAL WITH FEE 153.9579

DEVELOPMENT

PRODUCTION

AIRFRAME QUANTITY	ENGINE QUANTITY	AIRFRAMES	ENGINES	AVIONICS	TOTAL WITH FEE	CUM TOTAL WITH FEE	CUM TOTAL WITH FEE	( SPARE ) (RESINES)
50	125	2.1356	.4347	.1072	2.7791	136.3028	290.8607	6.1786
100	250	1.5801	.3764	.1071	2.0635	205.9546	360.3125	9.4089
200	500	1.1930	.2954	.0938	1.5789	319.7744	459.7322	14.2556
300	750	1.0923	.2512	.0872	1.4309	362.7173	516.4522	16.3259
400	1000	1.0158	.2245	.0852	1.3555	405.5451	560.5030	18.2657
600	1500	.9173	.2186	.0847	1.2201	489.0545	642.0125	21.8951
800	2000	.8752	.1937	.0837	1.0559	534.1565	788.1144	26.3485
1000	2500	.8365	.1714	.0833	.9579	585.2913	920.7492	31.2839
500	1250	.5414	.1595	.0835	.8893	693.2650	1043.2229	33.8639
		.4322	.2015	.0825	1.1255	593.4204	717.2793	25.1918

UNIT

50	125	1.2141	.3079	.1017	1.6237
100	250	.9256	.2257	.0877	1.2448
200	500	.7117	.1792	.0826	.9755
300	750	.6357	.1583	.0805	.8054
400	1000	.5841	.1490	.0807	.7541
600	1500	.5415	.1276	.0875	.7800
800	2000	.5359	.1167	.0857	.6932
1000	2500	.5258	.1147	.0835	.6382
500	1250	.3126	.1229	.0854	.5369
					.7286

ASD/SD24 COST ESTIMATES  
FOR  
RECONFIGURING THE UPT-IFS COMPLEXES

1. This attachment provides the estimated costs for reconfiguring some or all of the T-37 and T-38 Undergraduate Pilot Training - Instrument Flight Simulator (UPT-IFS) complexes. The estimates are based upon program information supplied by Capt Steve Joseph (ATC/XPO), proposed configuration information supplied by Mr. Jerry Estepp (ASD/XRL), and assumptions made by ASD/SD24 personnel.

2. ATC is in the process of analyzing three alternative aircraft programs for UPT in the mid-1980s. The UPT-IFS complexes would be modified to represent the aircraft in the UPT program at that time.

a. One alternative (XT-1) is to replace only the aging T-37 aircraft and, correspondingly, reconfigure the T-37 UPT-IFS complexes.

b. Another alternative (XT-2) is to buy one new airplane to replace both the T-37 and T-38 aircraft. In this case, all UPT-IFS complexes would be reconfigured.

c. The final alternative (XT-3) is to buy a new airplane to use as the basic primary trainer, to replace the T-37, and also function as a tanker/transport/bomber (TTB) trainer for those pilots designated to fly that type of airplane. The pilots not selected to continue in the TTB aircraft would fly the T-38 as a basic fighter/attack aircraft. In the XT-3 program all of the T-37 and some of the T-38 UPT-IFS complexes would be reconfigured.

3. The cost estimates were developed in the following manner.

a. First, using the information cited above and knowledge of the existing UPT-IFS systems, percentage estimates of the commonality between subsystems in the existing UPT-IFS system (T-37, T-38, or both) and the proposed systems (XT-1, XT-2, or XT-3) were made (p. J-8).

b. Second, the percentage estimates for each subsystem were applied to the latest costs reported in the UPT-IFS Cost Performance Reports (CPRs) submitted by Singer Corporation, Binghamton, NY (p. J-9).

c. Third, the total cost for each alternative system was based on the estimated cost of modifying each complex and the number of complexes to be reconfigured (p. J-9).

The modification schedule estimates for the three alternative programs are shown on page J-10. The following paragraphs explain assumptions that were used in estimating the reconfiguration costs and schedules.

4. Basic Assumptions.

a. The training tasks to be accomplished in the reconfigured UPT-IFSS, for any of the alternatives, would be related to instrument flight training.

b. The modification of the UPT-IFS complexes would be based on a competitive procurement.

c. The third seat in the XT-3 aircraft would not be included in the simulator; however, the same spacial relationships would be maintained. This assumption was suggested by Capt Joseph. It is envisioned that the cockpit area of the XT-3 will be larger than either of the current aircraft and have other than a "canopy" access to the pilot positions.

d. Additional equipment such as collision avoidance, global positioning, head-up display (HUD) and radar are not included in the UPT-IFSS and are not considered in the commonality percentages.

e. The visual systems would be computer generated imagery (CGI) systems, rather than the current terrain model board systems. This assumption was suggested by Capt Joseph.

f. The cockpit/motion platform designs would not increase the size of the motion excursion envelope and thereby impact the facility design. However, if the final cockpit and visual display designs are significantly larger than the current UPT-IFS designs, the motion excursion limits could result in facility modifications.

5. The following paragraphs discuss, by line number, the factors involved in estimating the equipment (hardware and software) commonality percentages. The percentages are shown on page J-8.

a. Line 1a - Changes to the operator's station could include the keyboard and the power distribution system.

b. Line 1b - Motion hardware should not be impacted for the XT-1 and XT-2 since the cockpits are anticipated to be similar to the T-37 and T-38 aircraft. The XT-3 is envisioned to be a larger aircraft with a larger crewstation area with other than "canopy" access to the pilot positions.

c. Line 1c - No cockpit commonality is anticipated.

d. Line 1d - Any changes to the computational hardware would be in the area of core memory and input/output (I/O) hardware.

e. Line 1e - The instructor stations in the T-37 and T-38 simulator cockpits contain the simulator peculiar controls and are adapted to the particular cockpits. Therefore, no commonality is anticipated.

f. Line 1f - Since the assumption has been made that the visual systems will be CIG, no commonality is anticipated.

g. Line 2a - Changes to the operating programs are anticipated in the areas of frame times (iteration rates) and integration schemes. Diagnostic programs should change due to changes in the cockpit hardware and I/O hardware.

h. Line 2b

- Flight: New aerodynamic model based on XT-1, XT-2, or XT-3 flight test data.

- Navigation/communications: The commonality shown here is the basic earth coordinated position/navigation modeling and does not include any common communication/navigation system models.

- Training systems and advanced training programs: These systems/programs need to be adapted to other software program changes as previously discussed.

i. Line 3 - With the information presently available, it is virtually impossible to assess a facility impact. If the cockpit and visual display designs are significantly larger than the UPT-IFS designs, the motion excursion envelope could be increased; thereby, impacting facility design.

6. Cost estimates. The cost estimates shown on page J-9 are based on the commonality percentages and actual and estimated costs reported in Singer's UPT-IFS CPRs. It was not possible to estimate separate costs for the operator's and the on-board instructor's stations. The unit costs for reconfiguring the UPT-IFS complexes are given in millions of FY77 dollars and unescalated. The cost estimates are for hardware and software only. The first unit costs include non-recurring hardware and software costs. Follow-on unit costs include only recurring hardware costs. Costs for spares, support equipment, and subsequent modifications are not included. The total costs are based on the unit costs for each complex and the number of complexes to be reconfigured. The following numbers of complexes to be reconfigured were supplied by Capt Joseph.

a. XT-1: 11 (all T-37 UPT-IFS complexes)

b. XT-2: 22 (all T-37 and T-38 UPT-IFS complexes)

c. XT-3: 16 (all T-37 and 5 T-38 complexes) The 5 T-38 complexes were arbitrarily selected by ASD/SD24 as being approximately half.

7. Schedule. The schedules are based on Capt Joseph's suggestion that the first complex have a ready for training (RFT) date in 1985. It must be understood that the aircraft must be designed and tested before the associated simulator design can be completed. The contract award and program direction dates were established based on the RFT dates.

SIMULATOR EQUIPMENT COMMONALITY ESTIMATES\*

PERCENTAGE OF COMMONALITY WITH T-37/T-38 IFS

XT-1  
IFS

XT-2  
IFS

XT-3  
IFS

1. Hardware

a. Operator's station (Includes electronic interfaces/power distribution, etc.)	90	90	90
b. Motion system (Includes platform)	100	100	70
c. Cockpit	0	0	0
d. Computational System	95	95	95
e. Instructor's Station (Adapt T-37 or T-38 design)	0	0	0
f. Visual System	0	0	0

T  
T  
8

2. Software

a. Computer - real time support programs	95	95	95
- program generation programs	90	90	90
- operating programs	50	50	50
- diagnostic programs	50	50	50
b. Simulator - flight	0	0	0
- navigation/communications	25	25	25
- training systems	80	80	80
- advanced training programs	75	75	75
3. <u>Facility Design</u>	100	100	100

\* Possible error estimated at  $\pm 20\%$ .

RECONFIGURATION EQUIPMENT COST ESTIMATES (IN MILLIONS OF UNESCALATED FY77\$)

	<u>XT-1</u> IFS	<u>XT-2</u> IFS	<u>XT-3</u> IFS
1. Hardware			
a. Operator's and on-board instructor's stations (Includes electronic interfaces, power distribution, etc.)	\$ .01	\$ .01	\$ .01
b. Motion system (Includes platform)	0	0	.11
c. Cockpit	1.16	1.16	1.16
d. Computational System Hardware	.02	.02	.02
e. Visual System*	3.08	3.08	3.08
2. Software	<u>.73</u>	<u>.73</u>	<u>.73</u>
3. Subtotal (1st complex)	\$ 5.00	\$ 5.00	\$ 5.11
4. Follow-on Complex Cost**	\$ 2.99	\$ 2.99	\$ 3.07
5. Subtotal (Follow-on complexes)	\$29.90+	\$62.79++	\$46.05+++
6. Total	\$34.90	\$67.79	\$51.16

\* These costs are identical to those submitted in ASD/SD24 letter, 1 Mar 77, UPT-IFS Visual Costs & Impact Modification Study.

\*\* The follow-on complex costs were estimated at 70% of the first unit hardware costs.

+ Cost for 10 follow-on T-37 complexes.

++ Cost for 10 follow-on T-37 complexes and 11 T-38 complexes.

+++ Cost for 10 follow-on T-37 and 5 T-38 complexes.

SCHEDULES\*

ALTERNATIVES	FY 80	FY 81	FY 82	FY 83	FY 84	FY 85	FY 86	FY 87	FY 88
XT-1 IFS	D	(16 mos) $\Delta$	(30 mos)	1	(4)**	(6)	(1)		
XT-2 IFS	D	$\Delta$		1	(4)	(6)	(6)	(6)	22
XT-3 IFS	D	$\Delta$		1	(4)	(6)	(6)	(6)	16

Legend

- D - Program Direction
- $\Delta$  - Contract Award
- N - Nth unit Ready for Training (RFT)
- \* - A schedule for the aircraft was not available
- \*\* - Number RFT each fiscal year

APPENDIX K

STUDY COMMITTEE

<u>NAME</u>	<u>ORGANIZATION</u>	<u>DUTY TITLE</u>
Capt Steven G. Joseph	ATC/XPO	Study Director
Capt Francis L. Kapp	ATC/DOTF	Associate Study Director
Maj Berle F. Sullivan, Jr	ATC/LGXP	Logistics Plans Staff Off
Maj John A. Gallagher	ATC/XPQW	Systems Acquisition Off
Maj John W. Davis III	ATC/XPTI	Chief, ISD Division
Capt Larry W. Bufton	ATC/SDGA	Chief, T-37 Program Br
Mr. Al Huber	ATC/ACMF	Costing Team Leader

WORKING GROUP

Mr. Jimmie Griffin	ATC/XPO	Ops Research Analyst
Maj Melroy Borland	ATC/ACMF	Cost Analyst
Mr. Joe H. Lamb	ATC/DPXP	Personnel Officer
Mr. H.J. Chapman, Jr	ATC/DEPR	Civil Engineer
Maj M. Little	ATC/IGFF	Ch, T-37 Flying Safety Br
Capt Sidney Hirshberg	ATC/IGIX	IG Staff Officer
Capt Ian Cooke	ATC/IGIO	IG Staff Officer
Capt Billy J. Ely	ATC/LGXP	Logistics Plans Staff Off
Capt Dan B. Sassin	ATC/LGMAA	T-37 Logistics Staff Off
Capt Daniel E. Pettyjohn	ATC/XPQC	Cmd Acquisitions Stf Off
Lt Col Robert D. Hastings	ATC/XPMRT	Ch, Training Br
Capt W. M. Bridge	ATC/TTAT	Technical Tng Staff Off

SIGNIFICANT CONTRIBUTORS

Capt Victor J. Holubec	ATC/XPMMF	Ch, Flying Tng Br
CMSgt George F. O'Bryant	ATC/XPMRT	Manpower Analyst
MSgt Jose E. Guillen	ATC/XPMRT	Manpower Analyst
Lt Col Richard J. Harris	ATC/DOTC	Curriculum Developer

AERONAUTICAL SYSTEMS DIVISION

<u>NAME</u>	<u>ORGANIZATION</u>	<u>DUTY TITLE</u>
G. W. Estep	ASD/XRP	Study Manager
R. J. Maass	ASD/XRHD	Design Leader
D. P. Breidenbach	ASD/XRHD	Design
G. F. Quinn	ASD/XRHD	Design
R. J. O'Brien	ASD/XRHD	Structures/Weights
W. B. Bogle	ASD/XRHA	Avionics
E. D. Lefler	ASD/XRHI	Design Integration
J. Ondrejka	ASD/XRHI	Design Integration
G. A. Taylor	ASD/XRHI	Design Integration
R. P. Carmichael	ASD/XRHP	Propulsion
J. E. Brock	ASD/XRHP	Propulsion
J. C. McAtee	ASD/XRHP	Propulsion
G. Hobe	ASD/ENALD	Instruments
R. V. Burnett	ASD/ACCX	Cost

## BIBLIOGRAPHY

1. Mission Analysis on Future Undergraduate Pilot Training: 1975 through 1990, AFSC Report TR-72-001, Mission Analysis Study Group, Randolph AFB TX, January 1972.
2. Comparison of UPT - Generalized vs Specialized, DCS/Operations, Air Training Command, Randolph AFB TX, 5 March 1976.
3. Caso, Captain John, A Review of the Future Undergraduate Pilot Training Mission Analysis, Operations Analysis Report 74-4, Air Training Command, Randolph AFB TX, 22 August 1974.
4. Caso, Captain John, Calculation of T-37 & T-38 Fleet Insufficiency Dates Using the Equipment Life Expectancy Model (ELEM), Operations Analysis Report 74-1, Air Training Command, Randolph AFB TX, 20 March 1974.
5. USAF Program Flying Training, Vol 1, PFT 78-3, DCS/Operations, Air Training Command, Randolph AFB TX, October 1976.
6. AFSC Planning Activity Report, Air Force Systems Command, Andrews AFB, Washington DC, October 1976 (S).
7. Low Cost Aircraft Definition Study, Phase I, Northrop Report NOR 76-123, Northrop Corporation, July 1976.
8. Low Cost Aircraft Definition Study, Phase II, Northrop Report NOR 76-125, Northrop Corporation, July 1976.
9. Unsolicited Engineering Change Proposal ECP-CES-T-37B-391, Turbofan (Re-Engine) Program, Wallace Division, Cessna Aircraft Company, Wichita KS, 5 December 1975.
10. Joseph, Captain Steven, Analytic Review of Cessna Unsolicited ECP 391 Turbofan Re-Engine Program, 23 January 1976.
11. Economic Analysis of Cessna Unsolicited Proposal, AF/ACMC letter, 4 May 1976.

12. Large, Joseph P., Harry G. Campbell, David R. Cates, Parametric Equations for Estimating Aircraft Airframe Costs, RAND Report R-1693-1-PA&E, RAND Corporation, February 1976.
13. Boren, H. E., Jr., A Computer Model for Estimating Development and Procurement Costs of Aircraft (DAPCA-III), RAND Report R-1854-PR, RAND Corporation, March 1976.
14. AFM 173-10, USAF Cost and Planning Factors, Vol. I, 6 February 1975.
15. Griffin, Jimmie, T-37 and T-38 Utilization Rates, Operations Analysis Report 73-5, Air Training Command, Randolph AFB TX, 20 December 1973.
16. Future Undergraduate Pilot Training System Study, Final Report, Northrop Report NOR 70-149, Northrop Corporation, March 1971.
17. Woodruff, R. R. and W. V. Hagin, Dynamic Observation in T-37 Undergraduate Pilot Training (UPT) Link Trainers (T-4), AFHRL Report TR-72-61, February 1973.
18. Taylor, A. L. and R. L. Striegel, A Preliminary Investigation of VNAF Student's Achievement Undergoing UPT (T-41) Utilizing "The Guy in the Back Seat Concept", 1970.
19. Future Undergraduate Pilot Training (UPT) Study, Final Report, Lockheed Report LR 23578, Lockheed-California Company, 1 February 1971.
20. Major Changes in Undergraduate Pilot Training, 1939-1974, History and Research Division, Air Training Command, Randolph AFB TX 78148.
21. ASD/XRL, Next Generation Trainer (in writing at date of this report).