

AD-A053 623

COMPUTER SCIENCES CORP FALLS CHURCH VA
CONSIDERATIONS FOR A SMALL ECONOMICAL EARTH TERMINAL.(U)
JAN 78 W B MUNSON

F/G 17/2.1

DCA100-76-C-0089

UNCLASSIFIED

SRIF-AD-F100 049

NI

1 OF 1
AD
A053623



END
DATE
FILMED
6-78
DDC

AD-E100 049

AD A 053623

(4)



AD No. _____
DDC FILE COPY

DDC
RECEIVED
MAY 4 1978
B

DISTRIBUTION STATEMENT A
Approved for public release;
Distribution Unlimited

AD A 053623

CONSIDERATIONS FOR A
SMALL ECONOMICAL EARTH
TERMINAL

20 January 1978

AD No.
DDC FILE COPY

DDC
RECEIVED
MAY 4 1978
B

DISTRIBUTION STATEMENT A
Approved for public release;
Distribution Unlimited

UNCLASSIFIED, R420, 31 March 1978

SECURITY CLASSIFICATION OF THIS PAGE (When Data Entered)

REPORT DOCUMENTATION PAGE		READ INSTRUCTIONS BEFORE COMPLETING FORM
1. REPORT NUMBER	2. GOVT ACCESSION NO.	3. RECIPIENT'S CATALOG NUMBER
4. TITLE (and Subtitle) 6 Considerations for a Small Economical Earth Terminal.		5. TYPE OF REPORT & PERIOD COVERED 9 Final Report
7. AUTHOR(s) 10 William B./Munson		8. CONTRACT OR GRANT NUMBER(s) 15 DCA100-76-C-0089
9. PERFORMING ORGANIZATION NAME AND ADDRESS Computer Sciences Corporation 6565 Arlington Blvd Falls Church, VA 22046		10. PROGRAM ELEMENT, PROJECT, TASK AREA & WORK UNIT NUMBERS Task No. 001
11. CONTROLLING OFFICE NAME AND ADDRESS Defense Communications Engineering Center, R420 1860 Wiehle Avenue Reston, VA 22090		12. REPORT DATE 20 January 1978
14. MONITORING AGENCY NAME & ADDRESS (if different from Controlling Office) 18 SBLI 19 AD-E100 049		13. NUMBER OF PAGES 12 75 P.
		14. SECURITY CLASS. (of this report) UNCLASSIFIED
16. DISTRIBUTION STATEMENT (of this Report) Approved for public release; distribution unlimited		15a. DECLASSIFICATION/DOWNGRADING SCHEDULE
17. DISTRIBUTION STATEMENT (of the abstract entered in Block 20, if different from Report)		
18. SUPPLEMENTARY NOTES Review relevance five years from submission date		
19. KEY WORDS (Continue on reverse side if necessary and identify by block number) Earth Terminals Earth Stations Satellite Terminals Satellite Communications		
20. ABSTRACT (Continue on reverse side if necessary and identify by block number) A small economical earth terminal which could be used in the Defense Satellite Communications System (DSCS) in the early 1980's is described. This terminal would be small, relatively inexpensive (\$250,000), would stress fixed-plant location and unattended operation, and would be designed to support low-data-rate users. A network of such terminals, controlled by a larger network control terminal, is postulated. Communications links between terminals in this network would be established on a demand-assigned,		

DD FORM 1 JAN 73 1473

EDITION OF 1 NOV 65 IS OBSOLETE

UNCLASSIFIED

SECURITY CLASSIFICATION OF THIS PAGE (When Data Entered)

405717

hc

single-channel-per-carrier basis. Basic technical parameters of the terminal are derived based on system considerations. A G/T of 22 dB and an EIRP of 72 dBW are proposed. Support and acquisition requirements are also considered as a means of reducing costs. It is emphasized that judicious application of support and acquisition requirements is essential to achieve the desired cost constraints. It is concluded that the concept of a small economical earth terminal is feasible for use in the DSCS and could be procured in production quantities of 100 terminals within the cost constraints described.

RE: Classified reference-
AD-E100049

Document should remain for unlimited
distribution per Ms. Mary Bonnett,
DCA

ACCESSION for	
NTIS	White Section <input checked="" type="checkbox"/>
DOC	Buff Section <input type="checkbox"/>
UNANNOUNCED	<input type="checkbox"/>
JUSTIFICATION	
BY _____	
DISTRIBUTION/PUBLICATION CODES+ _____	
Dist. - AVAIL and/or SPECIAL _____	
A	

TABLE OF CONTENTS

<u>Section 1 - Introduction.</u>	1-1
<u>Section 2 - Background.</u>	2-1
2.1 Growth of Small Satellite Communications Terminals.	2-1
2.2 Commercial Terminal Descriptions and Costs	2-2
2.3 DSCS Satellite Description.	2-2
<u>Section 3 - Primary Requirements</u>	3-1
<u>Section 4 - Technical Considerations.</u>	4-1
4.1 Receive G/T Requirement.	4-1
4.2 EIRP Requirement.	4-11
4.3 SEET Modem	4-18
4.4 Transmit and Receive Carrier Bandwidth.	4-21
4.4.1 Amplitude Response Over Operating Bandwidth.	4-22
4.4.2 Phase Linearity Over Operating Bandwidth.	4-22
4.5 Spectral Purity	4-23
4.6 Frequency Stability	4-23
4.7 Gain of Transmit and Receive Chains	4-24
4.8 Antenna Tracking.	4-24
4.9 AM/PM Conversion	4-25
4.10 Reliability and Maintainability	4-26
4.11 Costs.	4-28
<u>Section 5 - Support and Acquisition Considerations.</u>	5-1
5.1 Introduction	5-1
5.2 Operation and Maintenance Concept.	5-1
5.2.1 Operation.	5-1
5.2.2 Maintenance	5-2
5.3 Logistic Support Factors.	5-2
5.3.1 Maintenance	5-2
5.3.2 Supply	5-4
5.3.3 Training.	5-5
5.3.4 Transportation, Packing and Handling.	5-6
5.3.5 Documentation.	5-7
5.3.6 Logistic Support and Associated Facilities	5-7
5.4 Statement of Work (SOW).	5-7
5.5 Contract Data Requirements List (CDRL).	5-17

TABLE OF CONTENTS (Cont'd)

<u>Section 6 - Conclusions</u>	6-1
<u>Attachment A - Warranty Considerations</u>	A-1

LIST OF ILLUSTRATIONS

Figure

2-1	Phases of the DSCS Satellites	2-4
2-2	DSCS II/DSCS IIa Functional Diagram	2-6
2-3	DSCS II & IIa Frequency Plan	2-7
2-4	DSCS III Functional Diagram	2-8
2-5	DSCS III Frequency Plan	2-9
4-1	Relationship Between Fill Rate and Satellite Power for Several Values of G/T	4-10
4-2	Relationship Between Receiver Temperature and Antenna Diameter for Various G/Ts	4-12
4-3	Possible Configuration of SEET	4-29

LIST OF TABLES

Table

2-1	Examples of Commercial Earth Terminals	2-3
2-2	DSCS II & IIa Parameters	2-5
2-3	DSCS III Effective Isotropic Radiated Power	2-11
2-4	DSCS III Transponder Gains	2-11
2-5	DSCS III Receive G/T	2-12
2-6	DSCS III Transmit Antenna Gains	2-12
2-7	DSCS III System Noise Temperature	2-12
4-1	SEET G/T Requirements for DSCS II and IIa	4-6
4-2	SEET G/T Requirements for DSCS III	4-7
4-3	Summary of Downlink Channels Available for Various G/Ts of the SEET	4-8
4-4	Earth Terminal Saturated EIRP Requirements for Use with DSCS II and IIa	4-15
4-5	Earth Terminal Saturated EIRP Requirements for Use with DSCS III	4-16
4-6	Reliability of a Small Terminal	4-27
4-7	Projected SEET Production Costs	4-30

SECTION 1 - INTRODUCTION

This report describes a network of Small Economical Earth Terminals (SEET) which could operate within the Defense Satellite Communications System (DSCS) beginning in the early 1980s to support a large number of small users whose individual capacities involve relatively low data rates and whose periods of activity are dictated by the individual users. This report also describes the mission and the capability which the SEET should be designed to support and the satellite resources that are available for the support of the network. In addition, this report presents technical considerations for the SEET, and how they can be implemented.

Features of the evolving DSCS that now make such a network of small terminals economically competitive with other means of communications are:

1. The increased complexity and weight of satellites which can now produce higher EIRPs and G/Ts than predecessors allows earth terminals to operate at lower transmit power and with less expensive receivers and more reliable subsystems.
2. The development of control systems for satellite communications networks allows the earth terminal to be operated from a central location and complete control of the network can be maintained without on-site personnel despite changing traffic demands and changing environments.
3. The user community which the SEET is intended to serve operates in a fixed-plant facility which is controlled environmentally so that ruggedness, quick removal and extreme environmental conditions do not impact on the terminal design to the degree of earlier military terminals.

It is envisioned that the SEET shall incorporate the following features so that it may be economically competitive with other communication systems:

1. Small, relatively simple terminal without the requirement for military parts and materials

2. Unattended operation (no operator and only fault clearing by simple substitution of modules by personnel with a minimum amount of training in earth terminal maintenance)
3. Control/Monitoring Functions communicated over a full-time secure orderwire link to the network control terminals
4. Use of standard "off-the-shelf" equipment with little or no modification for use in the SEET
5. Development of a logistics system which provides for simple replacement of modules to clear faults within the terminal and a low-cost replenishment system to maintain the required terminal availability.

A network of SEET terminals is intended to augment those terminals which are presently in the DSCS in a role which the existing terminals cannot fulfill. The present DSCS communications satellite earth terminals have evolved with emphasis placed upon high gain, large capacity, and hemispheric tracking systems. These terminals are employed in a high capacity strategic role. In addition, tactical and contingency mission earth terminals have been developed with a high degree of communications flexibility, rapid deployment, vehicular mobility, and aircraft transportability to serve a wide range of changing communications requirements. Together these systems have been developed to establish a network of nodal and non-nodal earth terminals in a multipoint transmission scheme for operation in clear and jammed environments. However, these terminals are expensive. The high cost for the large, fixed terminals, coupled with the relatively small number of high demand areas of the world, tends to restrict their deployment. In addition, the cost for the mobile terminals also restricts their numbers to support only high priority missions. Thus, the SEET is designed to supplement these existing terminals by providing a low capacity, fixed site capability at a minimum cost.

The most important aspect of the development of the SEET is that it is completely different from any of the military satellite earth terminal procurements which have preceded it. In addition to satisfying the technical requirements to be imposed upon

the procurement, the SEET must be economically competitive with other communication systems. Because this concept is drastically new for the military, each step presently employed in the procurement cycle must be investigated to assure that unnecessary costs are avoided and that the momentum developed to satisfactorily procure previous terminals with difficult technical requirements does not overtake this procurement of a terminal with difficult economic requirements.

The many factors bearing on the small terminal approach presented in this report are due largely to industry response to a DCEC-Commerce Business Daily Announcement (23 February 1976) seeking information pertinent to small low cost earth terminal concepts. These industry responses have been most welcome, have proven to be helpful in the preparation of this report, and are gratefully acknowledged.

SECTION 2 - BACKGROUND

2.1 GROWTH OF SMALL SATELLITE COMMUNICATIONS TERMINALS

The growth in launch payload capabilities has allowed bigger and more complex satellites to be placed in orbit. This has resulted in the use of smaller and more economical terminals for several reasons. First, the larger EIRP of the new satellites has meant that the earth terminal antenna diameter can be decreased and the receive system noise temperature can be increased. This, in turn, implies that the pedestal and tracking motors can be less complex and the use of simple solid-state receivers is possible. The higher G/T of new satellites has also allowed the use of lower transmit powers in the terminal. Finally, the higher payload capabilities have allowed the satellite designers to launch more on-board fuel. This has allowed the system designers to plan on maintaining much smaller satellite motions during the life of the satellite and, thus, fixed or limited-motion earth terminal antennas are possible.

In the past, the comparatively large expense to build an earth terminal also made it wise to bring the communication traffic to a few centers where the traffic could be multiplexed together prior to transmission over a satellite link. The larger satellites, in allowing smaller, less expensive terminals to be developed have, in turn, allowed the terminal to economically operate closer to the user without multiplexing as many users together.

The commercial communication satellite systems are also following the trend toward smaller and more economical earth terminals. It has been reported* that some countries in the world are now predicting requirements from 500 to 10,000 terminals as a means of introducing educational TV into various remote areas and/or providing at least one voice channel for local communication where up to now communication has been impossible. As a result, the small commercial earth terminal promises to be a major industry during the next decade. Examples of satellite systems

*Cuccia and Hellman, "Status Report: The Low-Cost Low-Capacity Earth Terminal," Microwave System News, June/July 1975, pp. 19-44.

which support this concept include WESTAR, ANIK, RCA GLOBCOM, Satellite Business Systems, MARISAT GTE, American Satellite Corporation, AT&T COMSTAR, and both the Indonesian and Japanese satellite systems.

2.2 COMMERCIAL TERMINAL DESCRIPTIONS AND COSTS

Presented in Table 2-1 are descriptions of various commercial terminals which are currently being constructed and the costs of those terminals. These are not projected or anticipated costs, but firm costs for which contracts have been let.

In contrast to these commercial terminal costs, the basic AN/MSC-61 terminal procurement cost is estimated to be \$4.9M each with \$0.5M for spare parts for each terminal (FY80 costs). The AN/MSC-61 has a 38-foot diameter antenna and provides a G/T of 34 dB/K and an EIRP of 119 dBm. This basic terminal is wired for 9 up and 15 down converters and is supplied with 5 up and 6 down converters. The AN/TSC-86 light terminal procurement cost is estimated to be \$2.6M with \$0.4M for spare parts for each terminal (FY80 costs). The AN/TSC-86 has an 8-foot antenna, a G/T of 18 dB/K, an EIRP of 103 dBm, and is supplied with 4 up and 4 down converters.

2.3 DSCS SATELLITE DESCRIPTION

During the time period that the SEET is expected to be in operation within the DSCS, it is presently envisioned that there will be at least three different DSCS satellites in use--DSCS II, DSCS IIa, and DSCS III. The approximate schedule for the operational life of each satellite is shown in Figure 2-1. If the SEET is operational in the early 1980s, it must be capable of satisfying the requirements with the DSCS II satellite. After the early 1980s, the primary satellites will be the DSCS IIa and the DSCS III. Thus, the development of the technical characteristics of the SEET must take into account the technical characteristics of each of these satellites. The important parameters for the DSCS II and IIa satellites are shown in Table 2-2, while their functional diagram and frequency plan are shown in Figures 2-2 and 2-3, respectively. The functional diagram for the DSCS III satellites is shown in Figure 2-4, and the DSCS III frequency plan in Figure 2-5. The important parameters of

Table 2-1. Examples of Commercial Earth Terminals

EXAMPLES OF COMMERCIAL EARTH TERMINALS

FREQUENCY BAND	SATELLITE	TYPE OF SMALL ANTENNA EARTH TERMINAL COMMUNICATIONS	ANTENNA DIAMETER (METERS)	TERMINAL G/T (dB/K)	HPA (W)	EIRP (dBW)	RECEIVER NOISE TEMP (°K)	PSK DATA		RECEIVE PERFORMANCE		COST*** (APPROX) (\$)
								DATA RATES (bps)	BER	R/C/N ₀ (dB Hz)	S/N(dB) COLON	
860 MHz	ATS-6	1 CH. TV + 2 CH. AUDIO (RECEIVE ONLY)	3.05	-4.9			870 (SYSTEM NOISE TEMP)			48.1	45.4	1000
860 MHz	ATS-6	1 CH. TV + 2 CH. AUDIO. RECEIVE ONLY	4.50 3.00				290			40.0	36.0	1000
15 GHz	MARISAT	DUPLEX VOICE, DUPLEX DATA, AND FACSIMILE	1.22	-4	35-50		437 (SYSTEM NOISE TEMP)	300 1200 2400	10.5 10.5 10.3			52,000 - BUY + INSTALLATION OR LEASE 1300 mo
2.2-2.6 GHz	ATS-6	RECEIVE ONLY VIDEO	3.00	8.0	90		438				49.0	5000
4/6 GHz	WESTAR ANIK RCA SATCOM INTELSAT	Tx/Rx VIDEO + Tx/Rx DATA	10.00	13.2 WITH TRANS-AMP	300						43.8	400,000**
		BUSH TERMINALS (RECEIVE TV ONLY)		20.0 WITH UNCOOLED PAR AMP	1500							450,000**
		TV RX ONLY	4.50	19.7	40		190					34,000
		SCPC W/TV RX		13.2			190					26,000
12/14 GHz	CTS JBS COMSTAR	(A) VIDEO RECOVERY (B) SCPC DUPLEX VOICE (3 CHANNELS) (C) DUPLEX DATA (D) VIDEO RECOVERY ONLY (E) VIDEO RECEIVE AND SCPC DUPLEX DATA (F) TDMA DATA (G) VIDEO TX/RX (H) TDMA HIGH RATE DATA	1.50 1.50 2.50 2.50 3.00 3.50 5.00 5.00	13.0 13.0 13.0 21.5 21.5 21.5 30.0 30.0			945 945 3665 300 795 795 197 197	3200 50K 1.5 M 60 M	10 ⁻⁷			100,000 27,700 40,500 67,500 75,100 77,800 107,000 93,400 400,000

**PEAK TO PEAK VIDEO SIGNALS TO RMS WEIGHTED NOISE RATIO

***PRICE FOR REDUNDANT SYSTEM

****PRICE INCLUDES ALL NECESSARY SIGNAL PROCESSING EQUIPMENT

	NO. OF SATELLITES LAUNCHED	CALENDAR YEAR							
		1977	1978	1979	1980	1981	1982	1983	1984
DSCS II	6	—	—	—	—	—	—	—	—
DSCS IIa	4			—	—	—	—	—	—
DSCS III	8*			(1)	(1)	—	—	—	—

*PLANNED AS OF 1977

(1) DEMONSTRATION FLIGHT SATELLITES TO BE USED OPERATIONALLY

Figure 2-1. Phases of the DSCS Satellites

Table 2-2. DSCS II & IIA Parameters (NC Narrow Coverage Dish; AC Defocused Dish for Area Coverage, EC Earth Coverage Horn)

TRANSPONDER GAINS	DSCS II, IIA
NC/AC TO NC/AC	97.50 dB
EC TO NC/AC	102.50 dB
NC/AC TO EC	93.25 dB
EC TO EC	104.25 dB

	TRANSMIT ANTENNA GAINS (1)	RECEIVE G/T(1)	SYSTEM NOISE TEMPERATURE
NC	34.3 dBi	- 3 dB/K	5500°K (37.4 dB 1°K)
AC	23.9 dBi	-13 dB/K	5500°K (37.4 dB 1°K)
EC	17.5 dBi	-16 dB/K	1970°K (32.9 dB 1°K)

	SATURATED EIRP (dBw)(1)				
	DSCS II		DSCS IIA		
	100%	50%	100%	75%	25%
NC	43.3	40.3	46.3	N/A	40.3
AC	32.9	29.9	36.0	34.7	N/A
EC	28.5		31.5		

(1) Edge of coverage values

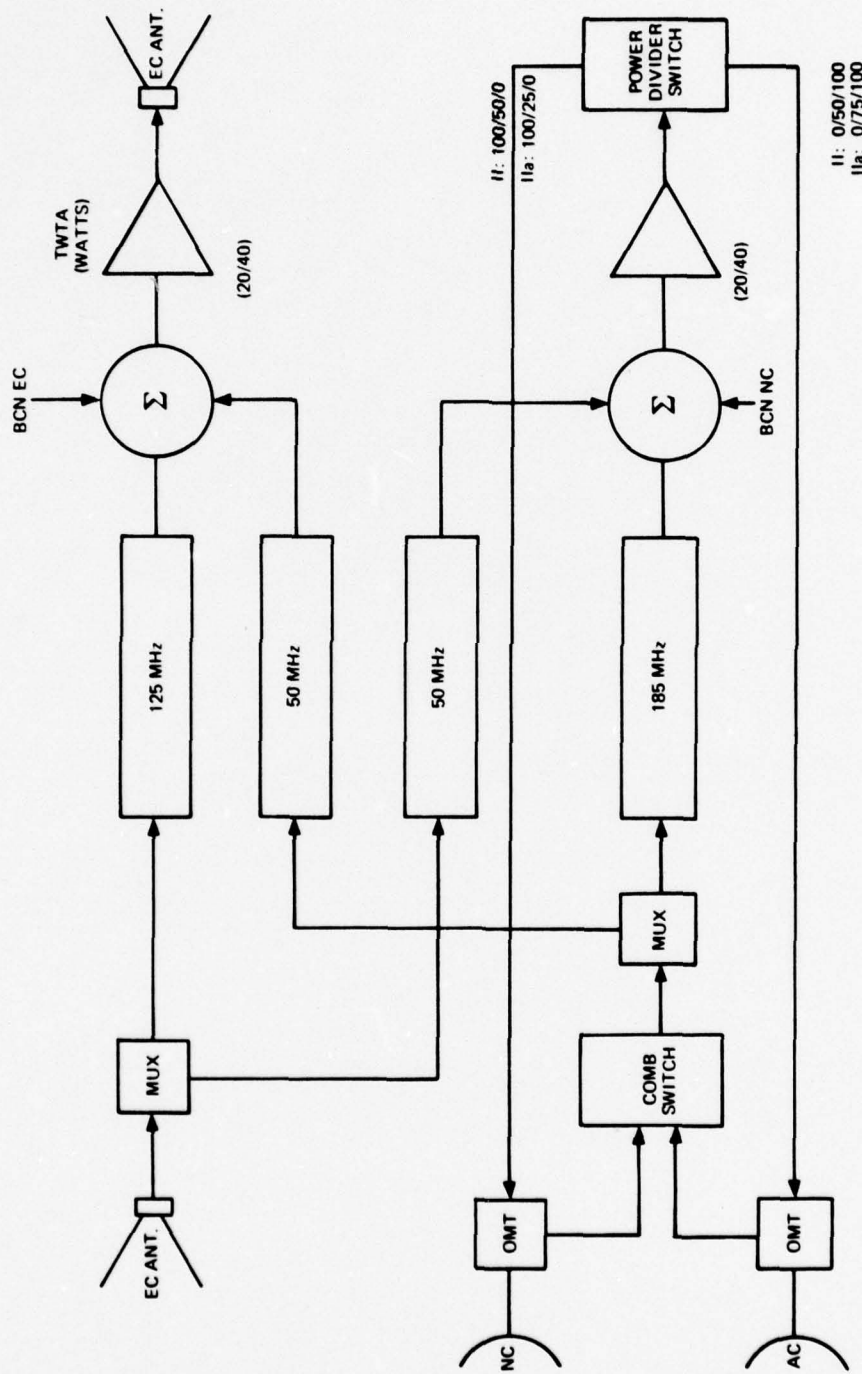

Figure 2-2. DSCS II/DSCS IIa Functional Diagram

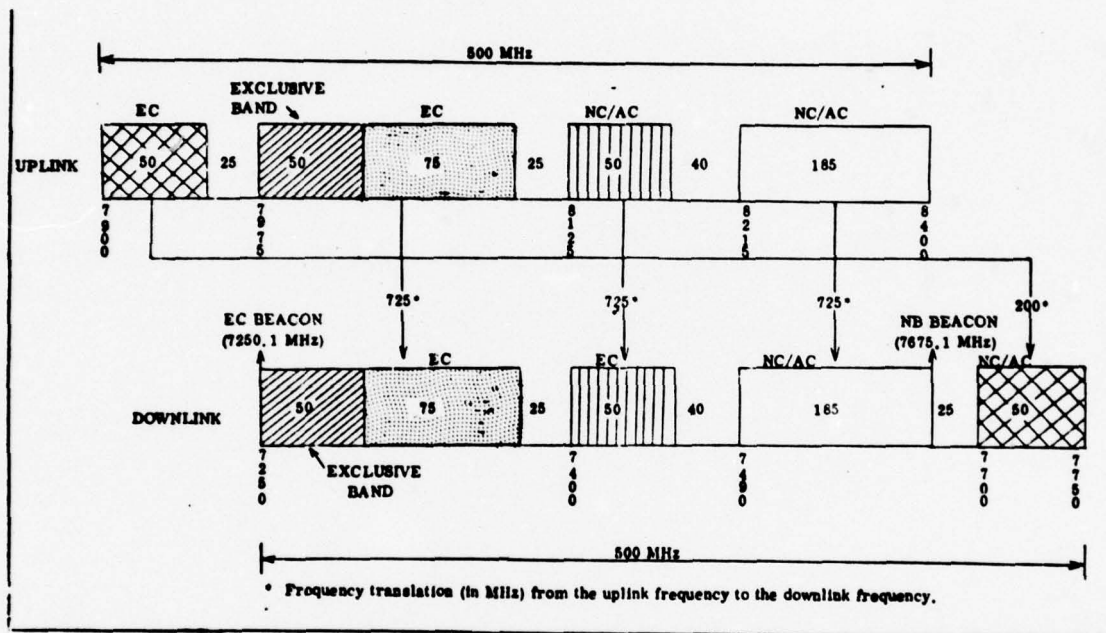

Figure 2-3. DSCS II & IIa Frequency Plan

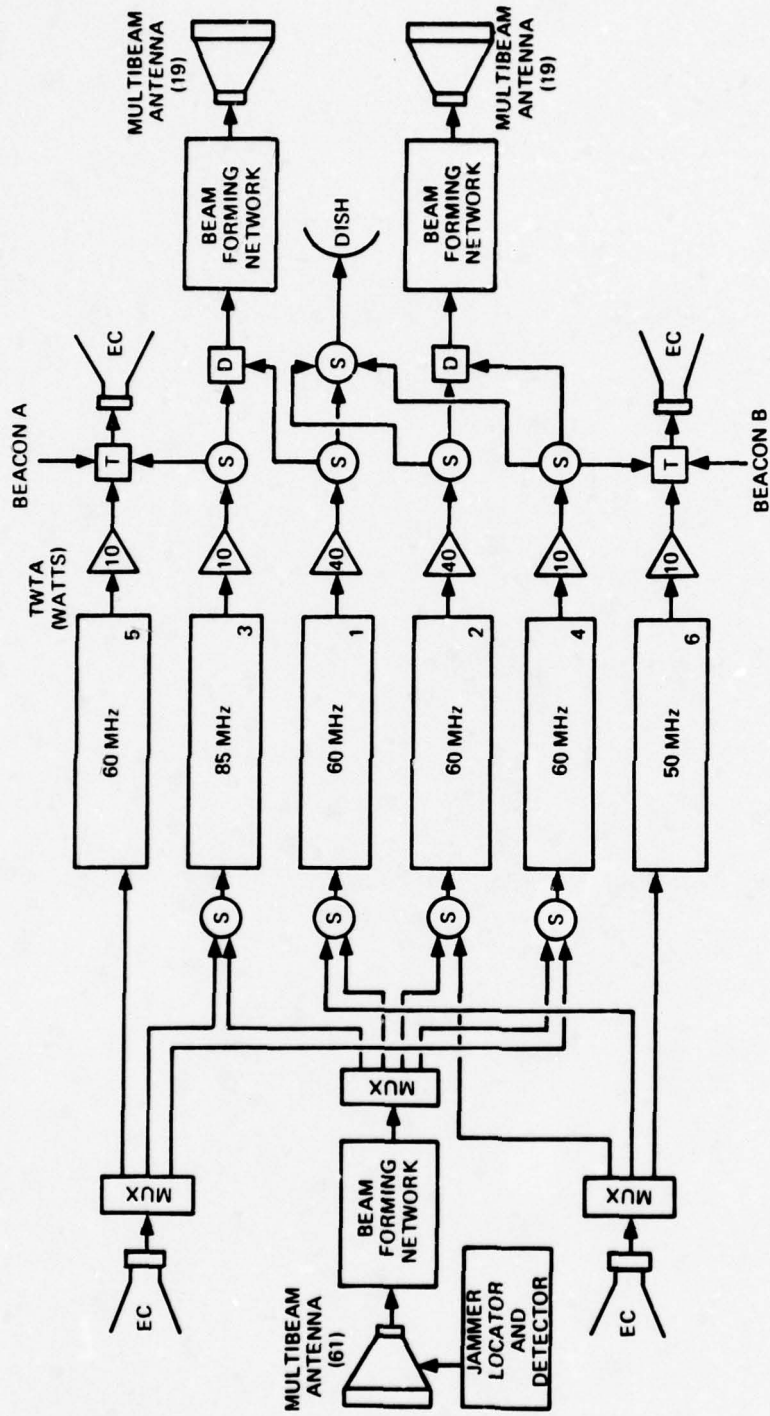

Figure 2-4. DSCS III Functional Diagram

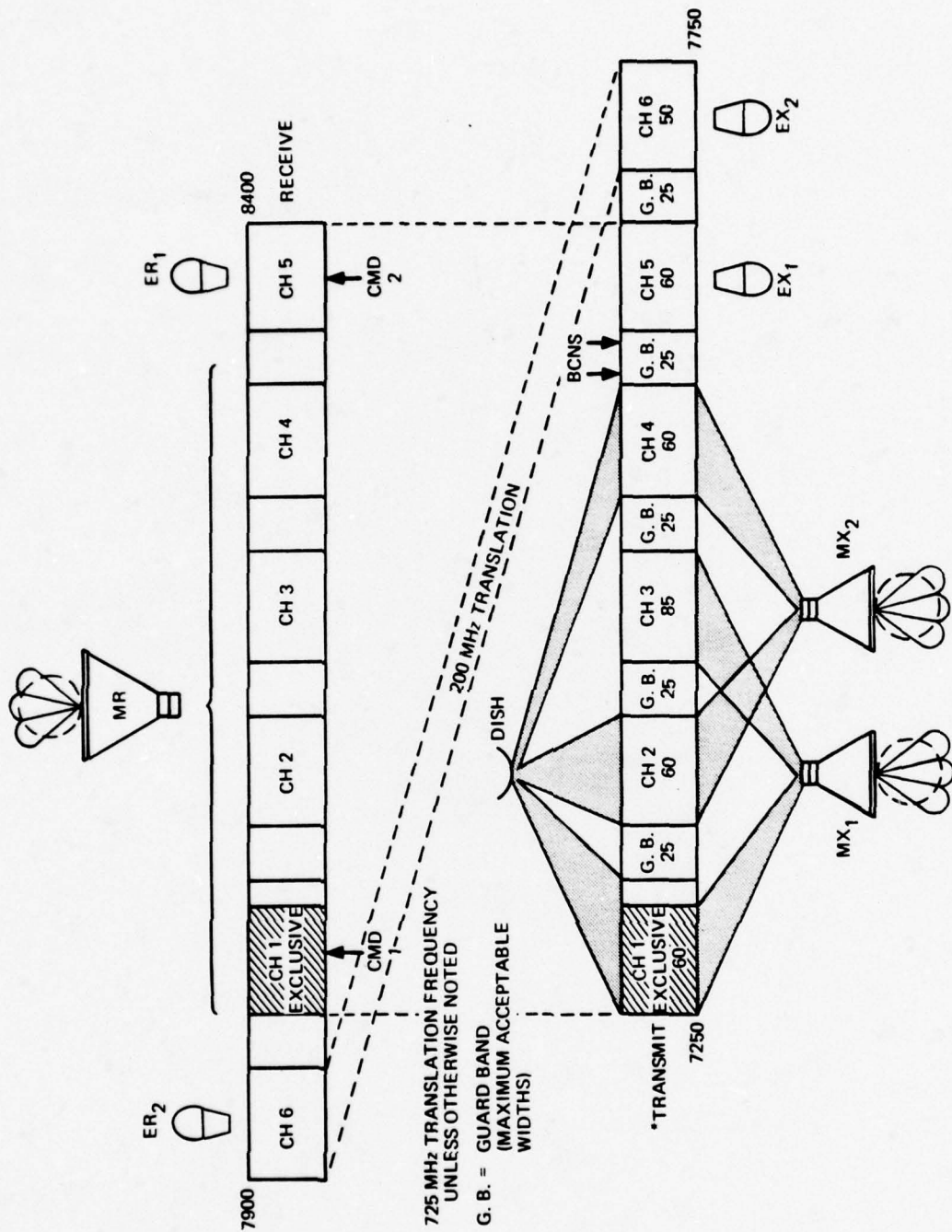

Figure 2-5. DSCS III Frequency Plan

the DSCS III are presented in Tables 2-3 through 2-7.

Several of the parameters shown in the tables require a brief explanation. To begin with, values are given for two different operational modes of the transmit multiple beam antennas (MBA) of the DSCS III satellites. The first mode, that of full earth coverage, is self-explanatory. However, the parameters for the second mode, that of incremental coverage, can vary over a wide range depending upon the actual configuration of the beams. The numbers shown in the tables assume a typical configuration which would be used, for instance, for the illumination of all of Europe and England and which would be feasible for use with a network of SEET terminals. Also, the value for the G/T of the uplink MBA has been chosen again assuming a typical configuration of this MBA for illumination of both Europe and England. And, finally, in the DSCS II and IIa tables, only the transponder gains for the normal operating states (DSCS II) and the approximate transponder gains for the anticipated operating states (DSCS IIa) have been provided. However, for DSCS III, the operating states have not yet been defined. Therefore, all of the gain states have been provided and will be used in the calculations.

Table 2-3. DSCS III Effective Isotropic Radiated Power (Saturated)

CHANNEL	DISH ⁽³⁾	MBA IN FULL EARTH COVERAGE MODE (1)	MBA IN INCREMENTAL COVERAGE MODE (2)	FIXED ⁽¹⁾ EARTH COVERAGE
1	44 dBw	29 dBw	37.7 dBw	
2	44 dBw	29 dBw	37.7 dBw	
3	--	23 dBw	31.7 dBw	25 dBw
4	37.5 dBw	23 dBw	31.7 dBw	25 dBw
5	--	--	--	25 dBw
6	--	--	--	25 dBw

- (1) EDGE OF COVERAGE EIRP.
- (2) ASSUMES A TYPICAL CONFIGURATION FOR ILLUMINATION OF EUROPE AND ENGLAND.
- (3) EIRP WITHIN 1.8° of TARGETED BEAM CENTROID.

Table 2-4. DSCS III Transponder Gains (including line losses)

CHANNEL DOWNLINK ANTENNA	1, 2		3, 4, 5, 6		
	MBA	DISH	MBA	EC	DISH
GAIN STATE 1	130.8	132.3	124.2	126.2	125.9
2	125.2	126.7	118.6	120.6	120.3
3	119.2	120.7	112.6	114.6	114.3
4	114.2	115.7	107.6	109.6	109.3
5	110.2	111.7	103.6	105.6	105.3
6	106.1	107.6	99.5	101.5	101.2
7	104.2	105.7	97.6	99.6	99.3
8	98.2	99.7	91.6	93.6	93.3
9	92.1	93.6	85.5	87.5	87.2

Table 2-5. DSCS III Receive G/T

ANTENNA	G/T (dB/K)
MBA - FULL EARTH COVERAGE MODE	-16.0
MBA - INCREMENTAL COVERAGE (1)	- 8.8
EARTH COVERAGE	-15.0

(1) ASSUMES A TYPICAL CONFIGURATION FOR ILLUMINATION OF EUROPE AND ENGLAND.

Table 2-6. DSCS III Transmit Antenna Gains (including line losses)

ANTENNA	GAIN (dBi)
MBA - FULL EARTH COVERAGE MODE (1)	16.0
MBA - INCREMENTAL COVERAGE (2)	24.7
DISH (3)	30.8
EARTH COVERAGE (1)	17.3

(1) EDGE OF EARTH

(2) ASSUMES A TYPICAL CONFIGURATION FOR ILLUMINATION OF EUROPE AND ENGLAND.

(3) 1.8° CONTOUR.

Table 2-7. DSCS III System Noise Temperature

UPLINK ANTENNA	SYSTEM NOISE TEMPERATURE
EC	1513.6°K (31.8 dB 1°K)
MBA	1380.4°K (31.4 dB 1°K)

SECTION 3 - PRIMARY REQUIREMENTS

The SEET should be capable of meeting the following requirements.

1. The acquisition cost of the SEET without spares should be less than \$250,000 per terminal in production quantities of 100 terminals. The terminal will consist of all components from RF to the user baseband which are necessary to satisfy the requirements of this section. To meet this cost, each aspect of the development, production, operation, and support of this terminal must be carefully evaluated to assure that the most cost effective approaches are used. For example, it is anticipated that standard commercially available equipment shall suffice rather than equipments which must be built to full military specifications. In addition, logistic support through contractor support or warranties rather than the Federal Stock System should be evaluated.
2. The SEET should be capable of supporting two (expandable to six) 32-kbps full-duplex secure-voice communication links through the DSCS to other SEETs and one secure orderwire link to a network control terminal. These numbers represent typical secure-voice requirements of low data-rate, fixed-site users in overseas locations. In addition, the SEET should be expandable to support the addition of one 1.5-Mbps duplex communication link to another SEET. No antijam capability is planned for this terminal.
3. The SEET should be configured so that any network of SEETs can be supported by a single satellite without using an excessive amount of that satellite's available power. For the purposes of this report, a design goal of 10 percent of the total power of the satellite will be allocated to the SEET network.
4. Interim operational capability of the SEET network is postulated for the early 1980s with full capability in the late 1980s. The maximum number of small economical earth terminals supported by any one satellite shall be 100. It is assumed that the user duty cycles are such that no more than 20 terminals access the satellite with their two 32-kbps secure-voice links at

any one time. The 32-kbps links should be supported on a demand assigned single channel per carrier (SCPC) basis with assignments made by the network control terminal.

5. The control of the SEET should be provided through an orderwire from a large network control terminal such as an AN/FSC-78. The orderwire links of all the terminals in the network should access the satellite on a full-time TDMA basis. No full-time operator should be required at the SEET.
6. Except for the antenna and pedestal, the SEET should be enclosed in a fixed plant, preferably already existing, contiguous with other electronic equipments. Other than personnel in the area who are available to clear faults in the SEET as indicated by the fault monitoring and indicating subsystem, the terminal should operate unattended. For the most part, faults should be cleared by simple substitution of modules. Except for the simplest of repairs and adjustments, no repairs or adjustments should be made at the terminal.
7. A terminal availability of 0.994 is required for the design life of the terminal of 15 years.
8. The terminal may be moved to other fixed plant sites as many as five times during its expected life. The removal of all major components of the SEET should require no more than 7 days. SEET installation should require no more than 14 days exclusive of site preparation.

SECTION 4 - TECHNICAL CONSIDERATIONS

4.1 RECEIVE G/T REQUIREMENT

The three satellites, the several channels, and the many switching arrangements in the channels leave many combinations of parameters to be investigated in order to determine what G/T is most appropriate for the SEET to economically operate in the DSCS. The fundamental relationship for determining the G/T of the SEET is

$$(G/T)'_{EFF} = R' + (E_B/N_o)' + M' - EIRP'_s - TD' + k' + TPL' \quad (4-1)$$

where $(G/T)'_{EFF}$ is the effective figure-of-merit to support the desired traffic in the presence of downlink noise from the satellite

R' is the information bit rate to be received by the terminal

$(E_B/N_o)'$ is the energy-per-bit to noise density ratio necessary for successful transmission

M' is the desired margin on the link

$EIRP'_s$ is the satellite edge of coverage effective isotropically radiated power allocated to support one SEET

TD' is an average tilt differential which is used to compensate for the fact that the SEET may not be at the edge of the satellite coverage

k' is Boltzmann's constant, $-228.6 \text{ dBw/}^\circ\text{K-Hz}$

TPL' is the total path loss between satellite and SEET.

Note: Primed variables are in terms of decibels; unprimed are numeric.

The data rate for the SEET network is composed of the following: (1) two full-duplex secure-voice 32-kbps circuits between 20 active terminals for a total bit rate of $(32\text{-kbps}) \cdot (2) \cdot (2) \cdot (20) = 2560\text{-kbps}$, (2) a SEET-to-control-terminal link via an orderwire for 100 terminals each bursting consecutively in a TDMA format at 32-kbps, and (3) a single control terminal to SEET coded orderwire broadcast for 100 terminals operating continuously at a 16-kbps rate, with an information data rate of 8-kbps. Thus, the total information data rate supported by the satellite is 2600-kbps. Of this total, each SEET will be receiving at most two voice circuits and the coded broadcast orderwire, for a total received data rate of 72-kbps.

The link margin is taken to be 4 dB. This value has been assigned based upon the anticipated performance of the networks under active control of an RTACS network after the early 1980s.

An E_B/N_o of 9.7 dB has been assigned to the 32-kbps, QPSK, secure-voice links, based on a probability of error of 10^{-3} , a modem implementation loss of 2.9 dB, and no forward error-correcting coding. An E_B/N_o of 7.2 dB has been assigned to the broadcast orderwire, based on a probability of error of 10^{-5} , a modem implementation loss of 2.9 dB, and the use of forward error-correcting coding.

The EIRPs for DSCS II AND IIa are presented in Table 2-2 and for DSCS III in Table 2-3. These values represent the maximum value which can be achieved at saturation. In this report, it is assumed that the actual operating point of the satellite is 3 dB less than the saturated power to suppress the generation of intermodulation products. In addition, in order to determine the EIRP allocated to support the three carriers to be received by each SEET out of the total of 81 carriers at the satellite, these EIRP values must be reduced by another $10 \log (3/81)$, or 14.3 dB. The TDMA pollback orderwire has been neglected in this total since it has been assumed that it will be received by a large terminal and, thus, its required EIRP will be insignificant compared to the total EIRP available.

Finally, the goal of 10 percent of the satellite power in support of the SEET network must be taken into account. For DSCS II, this means that 4 watts of transponder power

can be used to support the SEET network. Since 20 watts of power are available in each transponder, this means that 20 percent of the transponder EIRP can be used for the SEET network. This corresponds to an additional reduction of $10 \log (.2)$, or 7dB, from the saturated values. Thus, the saturated EIRP values for DSCS II must be backed off $(3) + (14.3) + (7) = 24.3\text{dB}$.

For DSCS IIa, 8 watts of transponder power can be used out of the 40 watts available, again resulting in the same 7dB reduction. Thus, for DSCS IIa, the saturated EIRP values must also be backed off by 24.3dB.

For DSCS III, 12 watts of transponder power can be used to meet the 10 percent goal. However, due to the DSCS III transponder configuration, it is more convenient to limit the power to 10 watts and assume that either one complete 10-watt transponder or 25 percent of a 40-watt transponder will be dedicated to the SEET network. Thus, for a first iteration, the EIRP values for the 10-watt transponders will be backed off $(3) + (14.3) = 17.3\text{dB}$, and those for the 40-watt tubes will be backed off $(3) + (14.3) + (6) = 23.3\text{dB}$.

The tilt differentials to be used in the calculations represent an average antenna gain increase for terminals which are uniformly distributed over the area covered by each beam rather than being at the edge of the beam. For DSCS II and IIa, it is assumed that, for the earth coverage beam, the edge of the coverage is 3.9dB down from the peak of the beam; for the area coverage (AC), the edge is 9.5dB below the peak; and for the narrow coverage (NC), the edge is 2.3dB down.* Thus, the tilt differentials will be taken to be 2.1dB for the EC antenna, 5.6dB for the AC antenna, and 1.2dB for the NC antenna.

For DSCS III, it is assumed that, for the EC beam, the edge of coverage is 4.5dB down from the peak of the beam; for the dish, the edge of coverage is 2.6dB down; for the MBA in its earth coverage mode, the edge of coverage is 2dB down;

*"DSCS Program Plan 1977-1982" (U), Defense Communications Agency, 8 Mar 76, pp 3-7 and B-6, CONFIDENTIAL.

and for the MBA in its incremental mode, the edge of coverage is 2dB down. Thus, the tilt differentials for DSCS III will be taken to be 2.5dB for the EC antenna, 1.5dB for the dish, 0.8dB for the MBA (EC), and 1dB for the MBA (IC).

The final parameter, that of total path loss, is assumed to be 203dB.

The relationship between the effective G/T of Equation 4-1 and the G/T of the earth terminal is developed from

$$(G/T)_{EFF} = \frac{G_{ET}}{T_{ET} + (N_S/k)} \quad (4-2)$$

where G_{ET} is the antenna gain of the earth terminal
 T_{ET} is the noise temperature of the earth terminal
 N_S is the noise power density at the output of the earth terminal antenna due to the noise radiated by the satellite.

The noise power density, N_S , is given by

$$N_S = \frac{kT_S G_{ST} G_{STX} G_{ET}}{L_S(TPL)} \quad (4-3)$$

where T_S is the system noise temperature of the satellite receiver chain
 G_{ST} is the gain of the satellite transponder
 L_S is the loss due to the power splitter (if applicable)
 G_{STX} is the gain of the satellite transmit antenna (including the tilt differential defined earlier).

Combining Equations 4-2 and 4-3 and solving for the terminal G/T yields

$$(G/T)_{ET} = \frac{(G/T)_{EFF}}{1 - \frac{T_S G_{ST} G_{STX} (G/T)_{EFF}}{L_S(TPL)}} \quad (4-4)$$

Using these equations and the satellite parameters previously presented, the G/T's required by the SEET to support the network of 100 terminals (20 active at any one time) can easily be calculated. The resulting G/T's for use with DSCS II and IIa are presented in Table 4-1, while those for DSCS III are shown in Table 4-2. In addition, these results are summarized for the various satellite downlink channels in Table 4-3.

From Table 4-3, it can be seen that a SEET with a G/T of less than 20 dB/K would be severely limited in the number of downlink channels with which it could be used. With DSCS II and IIa, the SEET network could only operate in the NC/AC-NC or the EC-NC channels provided that the full power went to the downlink NC antenna. Since it is not feasible to assume that the NC antenna would ever be dedicated for use of the SEET's, the operation of the network would thus be dependent on the availability of this antenna. This would seem to place an undue restriction on the operation of the SEET network. In addition, in DSCS III, the network would be restricted to use of the transmit dish of the satellite. Once again, use of this dish is geared towards other users, such as the Ground Mobile Forces. Thus, the SEET network again loses all flexibility in its operation.

In order to add flexibility to the network, a G/T of at least 23 dB/K would be required. This would allow the SEET to operate with the DSCS III MBA in its incremental mode. It would also allow it to operate with all downlink antenna combinations except the EC antenna in DSCS IIa, and all except the EC and the AC antenna, with the power divider turned on, in DSCS II. Increasing the G/T to 26 dB/K would only add the capability of using the DSCS II AC antenna while the transmit power is being split. However, since it is assumed that the DSCS II satellite will be operational only during the developing stages of the SEET networks, this antenna would probably be usable anyway due to the small number of terminals in the initial networks.

The next significant gain in flexibility occurs when the G/T is increased to 28 dB/K. This allows the SEET to use the EC antenna in both DSCS IIa and DSCS III, and

Table 4-1. SEET G/T Requirements for DSCS II and IIA

RECEIVE ANTENNA	TRANSMIT ANTENNA	DSCS II	DSCS IIA
NC OR AC	NC (ONLY) ⁽¹⁾	16.4	13.4
EC	NC (ONLY)	16.4	13.4
NC OR AC	AC (ONLY)	22.4	19.3
EC	AC (ONLY)	22.4	19.3
NC OR AC	NC (BOTH) ⁽²⁾	19.4	19.4
EC	NC (BOTH)	19.4	19.4
NC OR AC	AC (BOTH)	25.4	20.6
EC	AC (BOTH)	25.4	20.6
NC OR AC	EC	30.2	27.2
EC	EC	30.2	27.2

(1) "ONLY" IMPLIES THAT ONLY THE ANTENNA INDICATED IS BEING USED.

(2) "BOTH" IMPLIES THAT BOTH AC AND NC ARE BEING USED AND THAT THE TRANSMIT POWER IS BEING SHARED BETWEEN ANTENNAS.

Table 4-2. SEET G/T Requirements for DSCS III

TRANSMIT ANTENNA	GAIN SETTING ⁽¹⁾	CHANNELS 1, 2 (40 WATT)	CHANNELS 3, 4, 5, 6 (10 WATT)
MBA (EC)	3	31.6	30.3
	4	30.4	30.1
	5	30.2	30.0
	6	30.1	30.0
	7	30.0	30.0
	8	30.0	30.0
	9	30.0	30.0
MBA (IC) ⁽²⁾	3	22.7	21.4
	4	21.5	21.2
	5	21.3	21.1
	6	21.2	21.1
	7	21.1	21.1
	8	21.1	21.1
	9	21.1	21.1
DISH	3	16.6	15.3
	4	14.9	14.9
	5	14.5	14.9
	6	14.4	14.8
	7	14.4	14.8
	8	14.3	14.8
	9	14.3	14.8
EC	3	N/A	26.7
	4		26.4
	5		26.3
	6		26.3
	7		26.3
	8		26.3
	9		26.3

(1) SEET CANNOT BE SUPPORTED IN HIGH GAIN SETTINGS DUE TO EXCESS RERADIATED NOISE.

(2) MBA(IC) ASSUMES A TYPICAL CONFIGURATION FOR ILLUMINATION OF EUROPE AND ENGLAND.

Table 4-3. Summary of Downlink Channels Available for Various G/Ts of the SEET

SATELLITE	TRANSMIT ANTENNA	SEET REQUIRED G/T (dB/K)												
		14	16	17	20	21	22	23	26	27	28	31		32
II	NC (ONLY)			X	X	X	X	X	X	X	X	X	X	X
	AC (ONLY)								X	X	X	X	X	X
	NC (BOTH)				X	X	X		X	X	X	X	X	X
	AC (BOTH)								X	X	X	X	X	X
	EC											X	X	X
IIA	NC (ONLY)	X	X	X	X	X	X	X	X	X	X	X	X	X
	AC (ONLY)				X	X	X	X	X	X	X	X	X	X
	NC (BOTH)				X	X	X	X	X	X	X	X	X	X
	AC (BOTH)					X	X	X	X	X	X	X	X	X
	EC										X	X	X	X
III	MBA (EC) (40-WATT)													X
	MBA (EC) (10 WATT)												X	X
	MBA (IC) (40 WATT)								X	X	X	X	X	X
	MBA (IC) (10 WATT)							X	X	X	X	X	X	X
	DISH (40 WATT)			X	X	X	X	X	X	X	X	X	X	X
	DISH (10 WATT)		X	X	X	X	X	X	X	X	X	X	X	X
	EC (10 WATT)									X	X	X	X	X

would be the optimum situation. However, the cost penalty of obtaining such a large G/T more than offsets any operational gain. Thus, it appears that a G/T of 23 dB/K is a reasonable choice based on the assumptions of satellite power and terminal activity previously stated.

Now that the first iteration has been completed, it is necessary to go back and look at the assumptions to see what effect they have on the resulting G/T's. In particular, it was assumed that approximately 10 percent of the satellite power was available for support of the SEET network and that a maximum of 20 terminals would be accessing the satellite at any one time, i.e., 40 circuits out of a possible 200 circuits would be active, for a fill rate of 20 percent. The relationship between the usable satellite power, the fill rate, and the resulting G/T is shown in Figure 4-1. Although this figure is based on use of the DSCS II AC antenna, it would be similar for all downlink antennas. In addition, for simplicity, the G/T values plotted ignore the small effects of reradiated noise.

It can be seen from this figure that either increasing the percentage of available satellite power or decreasing the maximum fill rate will result in lower values of required G/T's. For example, increasing the available satellite power to 15 percent would result in a required G/T of approximately 21 dB/K, while decreasing the fill rate to approximately 14 percent would accomplish the same result.

The graph also points out one other interesting possibility; that is, the possibility of designing the SEET network to have a dynamic operating point in terms of satellite power and fill rate instead of a preset one. Since the network is to use SCPC, it should be possible for the network controller to automatically adjust the fill rate to compensate for changing demands for the satellite's power. In other words, during periods when surplus satellite power is available, the fill rate would be increased to make use of it as required. However, as the satellite becomes heavily loaded, the fill rate would be gradually decreased, thus lowering the percentage of the satellite power being used by the SEET network (increasing blocking) and making it available for other higher priority users.

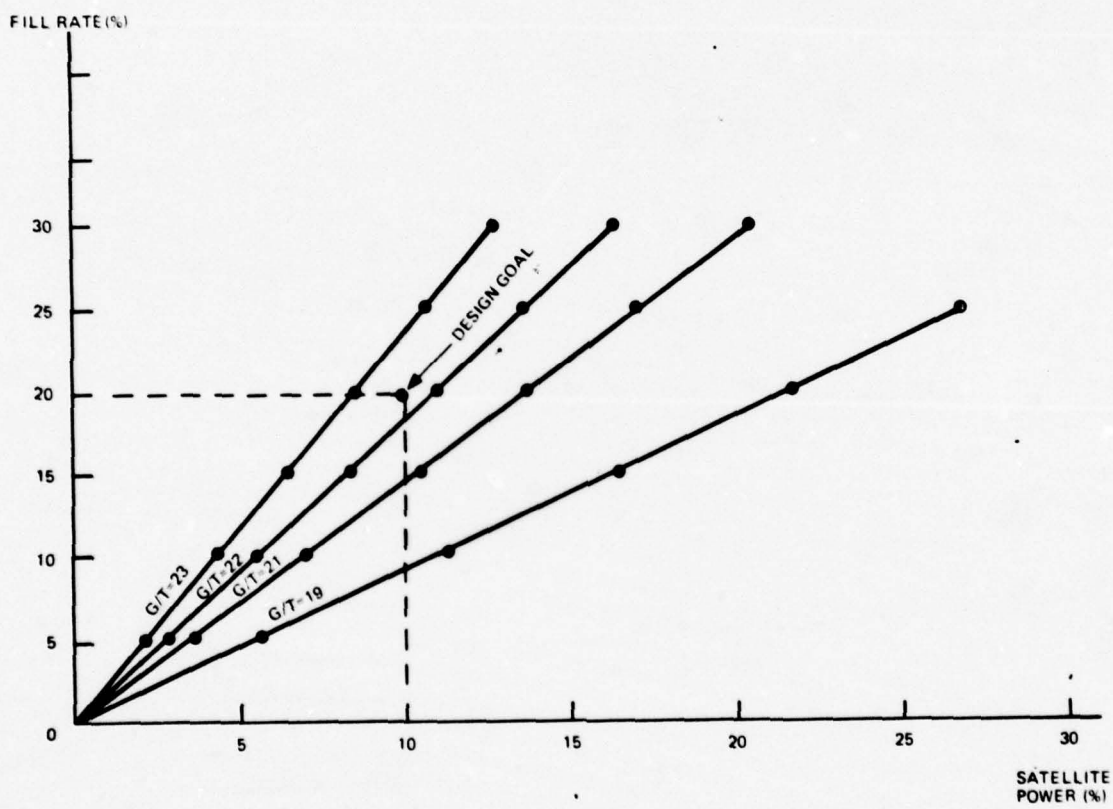

Figure 4-1. Relationship Between Fill Rate and Satellite Power for Several Values of G/T

Before specifying a desired G/T, one more factor needs to be taken into account. Figure 4-2 shows the relationship between receiver noise temperature and antenna diameter for several G/T's of interest. This figure is based upon an antenna noise temperature of 35°K and a line loss between antenna and receiver input of 1 dB. Thus, for example, a 250°K receiver noise temperature would result in a system noise temperature for the SEET of 420°K. Also included in the figure is the receiver noise temperature range within which field-effect transistor (FET) amplifiers are expected to be available in the early 1980's. FET amplifiers would be ideal for use in the SEET since they combine simplicity, low cost, and reliability, all of which are highly desirable. According to industry sources, FET amplifiers are expected to cost as little as \$2000 to \$4000 per unit in the early 1980's. This price range covers both the medium performance and the high performance FET's as indicated in Figure 4-2. Because of the high desirability of using a FET in the SEET, the G/T should be chosen such that a FET can be used while at the same time using an antenna small enough in size so that the cost of the SEET remains within its bounds.

Based on the preceding discussion, it appears reasonable to specify a G/T of 22 dB/K for the SEET. This will allow use of the desired downlink antennas, will come reasonably close to meeting the satellite power and fill rate goals, and will allow use of a FET receiver as long as the antenna diameter is greater than approximately 12 feet.

4.2 EIRP REQUIREMENT

The next characteristic of the SEET to be determined is that of its required EIRP. Each SEET is required to support two SCPC 32-kbps secure voice links and a TDMA pollback orderwire to the central control terminal. Since this pollback orderwire is received by a large terminal (G/T of 39 dB/K), the satellite power required for this circuit will be much less than that required for one of the voice circuits. However, since reradiated noise will significantly degrade the effective G/T of the large terminal at high transponder gain settings, the satellite EIRP required for this circuit will be included in the calculations. For simplicity, it will be assumed,

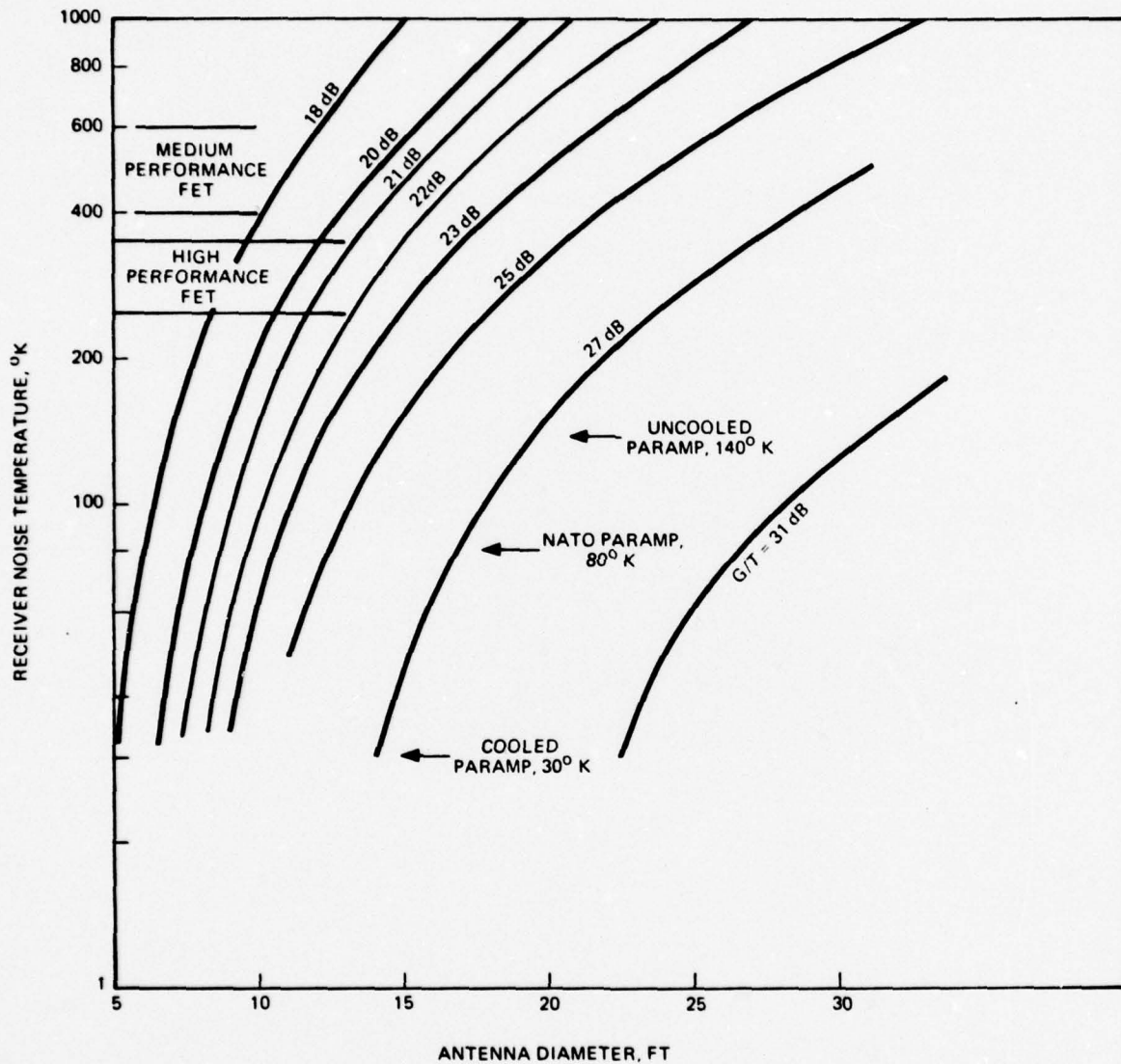

Figure 4-2. Relationship Between Receiver Temperature and Antenna Diameter for Various G/Ts (Antenna Temp = 35°K and 1dB line loss)

as before, that the available satellite EIRP is divided among the 40 voice circuits and the coded orderwire (81 carriers), and the EIRP required for the TDMA pollback circuit will be calculated separately. Since this additional EIRP will be small compared to the total available satellite EIRP, it will not affect any of the calculations made previously.

The EIRP of the terminal needed to capture enough power to maintain an acceptable downlink is given by:

$$EIRP'_{ET} = P'_R - G'_{ST} + (TPL)' - (G/T)'_S - T'_S - TD' \quad (4-5)$$

where $EIRP'_{ET}$ is the EIRP of the earth terminal

G'_{ST} is the gain of the satellite transponder

$(G/T)'_S$ is the G/T of the satellite

T'_S is the noise temperature of the satellite

TD' is the tilt differential for the uplink satellite antenna

P'_R is the power required to be radiated in the downlink in support of a SEET

The downlink power for one SEET is taken to be

$$P'_R = (EIRP)'_{SEET} - (G_{STX}) \quad (4-6)$$

where $(EIRP)'_{SEET}$ is the satellite EIRP allocated to each individual SEET (including the 3dB backoff) and G_{STX} is the edge of coverage gain of the satellite transmit antenna.

The values for $(EIRP)'_{SEET}$ can be determined from the satellite EIRP values presented in Tables 2-2 and 2-3 by first reducing these values by 3dB to account for backoff, and then by another 16.1dB to determine the EIRP required to support the two voice circuits of each SEET out of the total of 81 carriers present at the satellite. In addition, it will again be assumed that the SEET network will be allocated approximately 10 percent of the total power of the satellite. For DSCS II and IIa, 4 watts

and 8 watts, respectively, of power will be available out of the transponder power of 20 watts and 40 watts, respectively. This 20% figure again corresponds to a 7dB reduction. Thus, for DSCS II and IIa, the saturated EIRP values must be backed off a total of $(3) + (16.1) + (7) = 26.1$ dB.

For DSCS III, either an entire 10-watt transponder can be used, resulting in a backoff of $(3) + (16.1) = 19.1$ dB, or 25% of a 40-watt transponder can be used, resulting in a backoff of $(3) + (16.1) + (6) = 25.1$ dB from the saturated EIRP values shown. Using Equations (4-5) and (4-6), the saturated earth terminal EIRP's required to support acceptable links using the downlink antennas of interest can be calculated and are provided in Tables 4-4 and 4-5. These values again assume an earth terminal operating point 3dB backed off from saturation due to intermodulation considerations.

As can be seen from Table 4-4, a saturated earth terminal EIRP of 71 dBw would be sufficient to support the required links over the desired downlink antennas in both DSCS II and IIa, assuming the normal operational gain settings for the transponders. However, from Table 4-5, it can be seen that the EIRP requirements for DSCS III are potentially much more stringent, due to the numerous gain settings available for each transponder. In order to retain a certain amount of flexibility, the SEET network should be able to operate with any of the uplink antennas. Thus, according to Table 4-5, a saturated earth terminal EIRP of 93dBw would be required for the SEET to operate into any DSCS III uplink antenna at any gain setting. However, such a large EIRP value would be impossible to obtain in view of the cost constraints of the SEET.

A more realistic approach would be to pick an EIRP which would allow use of all uplink antennas for several gain settings rather than for all gain settings. When using the 10-watt channels, this approach is particularly valid, both because it has been assumed that a complete transponder has been dedicated to support the SEET and also because of the fact that reradiated noise, which is the reason for using lower transponder gains, is of minor concern when dealing with small terminals.

Table 4-4. Earth Terminal Saturated EIRP Requirements
for Use with DSCS II and IIa

RECEIVE ANTENNA	TRANSMIT ANTENNA	EIRP _{ET} (dBw)	
		DSCS II	DSCS IIA
NC/AC	NC (ONLY)	61.5	64.4
EC	NC (ONLY)	67.5	70.4
NC/AC	AC (ONLY)	61.5	64.6
EC	AC (ONLY)	67.5	70.6
NC/AC	NC (BOTH)	58.5	58.5
EC	NC (BOTH)	64.5	64.5
NC/AC	AC (BOTH)	58.6	63.3
EC	AC (BOTH)	64.6	69.3

Table 4-5. Earth Terminal Saturated EIRP Requirements
for Use with DSCS III

RX ANTENNA	TX ANTENNA	GAIN SETTING	EIRP _{ET} (dBw)	
			40-WATT CHANNEL	10-WATT CHANNEL
MBA (EC)	DISH	3	58.2	63.4
		4	62.6	68.2
		5	66.4	72.1
		6	70.4	76.2
		7	72.2	78.1
		8	78.2	84.1
		9	84.3	90.2
MBA (IC)	DISH	3	50.8	56.0
		4	55.2	60.8
		5	59.0	64.7
		6	63.0	68.8
		7	64.8	70.7
		8	70.8	76.7
		9	76.9	82.6
EC	DISH	3	55.2	60.3
		4	59.5	65.1
		5	63.3	69.1
		6	67.3	73.1
		7	69.1	75.0
		8	75.1	81.0
		9	81.2	87.1

Table 4-5. Earth Terminal Saturated EIRP Requirements
for Use with DSCS III (Cont'd)

RX ANTENNA	TX ANTENNA	GAIN SETTING	EIRP _{ET} (dBw)	
			40-WATT CHANNEL	10-WATT CHANNEL
MBA (EC)	MBA (IC)	3	59.3	65.3
		4	63.8	70.2
		5	67.7	74.2
		6	71.7	78.3
		7	73.6	80.2
		8	79.6	86.2
		9	85.7	92.2
MBA (IC)	MBA (IC)	3	51.9	57.9
		4	56.4	62.8
		5	60.3	66.8
		6	64.3	70.9
		7	66.2	72.8
		8	72.2	78.8
		9	78.3	84.8
EC	MBA (IC)	3	56.3	62.2
		4	60.7	67.1
		5	64.6	71.1
		6	68.6	75.2
		7	70.5	77.1
		8	76.5	83.1
		9	82.6	89.1

On the other hand, when using a 40-watt channel, the transponder will be shared with other users. Thus, an EIRP must be chosen which will allow the use of the majority of the gain settings. From Table 4-5, it appears that an EIRP of 72dBw would be a reasonable choice to meet this requirement while at the same time be a small enough value so that the cost constraints of the SEET can also be met.

An EIRP of 72dBw could be obtained by several different combinations of earth terminal transmitter powers and antenna gains. Using a 12 foot antenna would result in a required transmitter power of approximately 500 watts (assuming a 2dB line loss). Increasing the antenna size to 15 feet would allow use of a 320-watt transmitter. Increasing the antenna even more, to 18 feet, would decrease the required transmitter power to approximately 225 watts.

Although any of these combinations could be used, the smaller diameter antenna would be preferable since increasing the antenna size is more cost-sensitive than increasing transmitter power within the ranges mentioned. Thus, a combination of a 15 foot antenna and a 320-watt transmitter would appear to be a reasonable choice in order to economically meet the EIRP requirement. This choice would also allow the G/T of 22dB/K to be met with the use of a medium-performance FET rather than with a high-performance FET which might not be as readily available as expected.

In summary, it appears that a G/T of 22dB/K and an EIRP of 72dBw provide the most performance within a reasonable cost frame. This performance could be obtained by using a 15 foot antenna, an FET lownoise amplifier, and a transmitter output power of approximately 320 watts.

4.3 SEET MODEM

The modem to be used with the SEET is an important facet of the terminal since it will not only provide the modulation and demodulation for the terminal network, but will also provide network control and terminal monitoring functions. There are several modems which presently exist which are capable of operating within the SEET network -

most notably, the Ohio State University TDMA modem* and the NSA UMSTEAD modem. The UMSTEAD is particularly attractive for this application. At present, the Advanced Development Model (ADM) has been completed and the development of the Engineering Development Model (EDM) is proceeding. It is contemplated that the UMSTEAD will be the basic equipment to be employed in the DSCS RTAC network for control communications and as such provides an attractive choice for the control and operation of the SEET network. Although this report uses the UMSTEAD as the basis for determining SEET parameters, further growth in modem technology should be monitored so that improved modems can be incorporated into the SEET by the 1980s.

The control philosophy for the UMSTEAD is based upon a large (AN/FSC-78 or equivalent) central Network Control Terminal (NCT) which controls and monitors the network of up to 100 SEETs. The control is provided by a TDM broadcast signal from the NCT to all the SEETs being served by the same satellite and a TDMA pollback signal from each of the remote terminals to the NCT. The second type of signal radiated by the SEET is the 32-kbps full-duplex demand-assigned SCPC communication link between individual SEETs in the network. Although the communications link is only established when the user desires, the broadcast and pollback links operate on a full-time basis.

The TDM broadcast consists of sequential transmission of N messages of 64 milliseconds each, where N is the number of remote terminals in the network. At the end of the N message frame, the sequence is repeated. Each message in the frame consists of: (1) a crypto synchronization bit sequence for locking the UMSTEAD crypto unit to the incoming carrier, (2) a unique word (unique to each remote terminal) which, if decoded, identifies the message as a message for that particular terminal, (3) a message identifier which is used for bookkeeping purposes, (4) the message, and (5) a control message to allow control of the remote terminal's functions. The message

*"Multifunction TDMA Techniques," R. J. Huff, Second Annual Report, 1 Feb 1973 to 31 Jan 1974, Electro Science Laboratory, Ohio State University, Report 3364-3, August 1974.

(item 4) contained in the broadcast to the remote terminal consists of power level, frequency, and sender and receiver identifiers for the new communication links to be created. The control message (item 5) consists of the control parameters which are needed to remotely monitor status and maintain control of all the remote terminals. The broadcast signal is Viterbi encoded at rate one-half into a 16-kbps digital stream that is modulated using BPSK.

At a specified time interval after the unique word (item 2) is successfully decoded, the remote terminal transmits a pollback signal to the NCT. This pollback signal follows a similar format to the broadcast in that it consists of a crypto synchronization sequence, a unique word, message identifier, and data. The difference is that there is a time period between sequential messages from remote terminals that allows the NCT to obtain both carrier and bit synchronization. The data transmitted from the remote terminal to the NCT is expected to consist of:

1. Antenna Position
2. Receiver Noise Level/LNA Temperature
3. Interfacility Link Amplifier Output Level (if required)
4. UMSTEAD Receiver Frequency Setting
5. UMSTEAD Transmit Frequency Setting
6. UMSTEAD Demodulator BER
7. UMSTEAD Channel Output Level
8. Power Amplifier Output Level
9. System Status/Faults
10. Call Requests and Link Identifiers.

The pollback is a 32-kbps QPSK message.

Once the NCT receives a Call Request with sender and receiver information, the NCT makes frequency and power level assignments to both remote terminals of interest. If the intended receiving terminal is busy on the two available channels, the user at the sending terminal receives a busy signal. If the sender has an assigned priority greater than the previously established link, an interrupt is allowed. The link provides full-

duplex secure-voice capability. The analog voice is first digitized using Continuously Variable Slope Delta Modulation (CVSD), and then modulated using QPSK at 32-kbps onto an SCPC RF carrier. At the completion of the message, the modem senses the user telephone being hung up and the link is removed.

Although the UMSTEAD operates over as much as a 36 MHz bandwidth and channel selections can be made over the 1440 possible 25 KHz SCPC channels in the band, the modem also has the capability of being program-set to operate over a bandwidth of less than 36 MHz or only over selected portions of the 36 MHz band. Since SCPC frequency selection is made by the modem at IF over the nominal 52 to 88 MHz band, the frequency settings of the earth terminal up and down converters will remain fixed on a day-to-day basis.

The UMSTEAD modem contains its own clock, Doppler, range and frequency drift correction, and crypto functions. In addition, it has the capability described earlier of dynamically adjusting the total number of calls allowed at any one time in response to an external input, such as an RTAC command.

The cost of the UMSTEAD modem in production is expected to be \$55K per unit, and the mean time between failures in the modem is 5,000 hours. Although the modem is designed so that it may operate as a single unit, if desired it may be paired with another modem which will automatically assume the functions of the online unit when it fails.

4.4 TRANSMIT AND RECEIVE CARRIER BANDWIDTH

The transmit and receive chains of the SEET (from IF through the antenna or vice versa) should be fixed tuned in the sense that the frequency translation between the center of the 36 MHz IF band (70 MHz) and the center of the 36 MHz RF bandwidth will change only when the terminal is moved or when either a new satellite or a new satellite channel is assigned. Up converters should be designed to operate anywhere in the 7.9 to 8.4 GHz transmit band and down converters anywhere in the 7.25 to 7.75 GHz receive band. Both should have an IF of 70 MHz nominal. At any instant, as

many as four carriers (two SCPC voice carriers, one pollback carrier and one pilot tone) with growth to eight carriers (six SCPC voice carriers, one pollback carrier and one pilot tone) could occupy the 36 MHz IF transmit or receive band. Allowances for future growth of the SEET include the incorporation of a 1.544 mbps channel into the terminal. It is assumed that this channel will be imposed on an RF carrier using either BPSK or QPSK. Thus, a bandwidth of either 3.1 MHz or 1.5 MHz must be assumed to support this 1.544 mbps channel anywhere in the transmit or receive band using separate up and down converters.

It is anticipated that the SEET frequency conversion units can operate with crystal oscillators as a reference frequency. The anticipated cost of these crystal units is expected to be approximately \$600 per unit. If, however, there is some uncertainty as to the number of frequency changes during the life of the terminal, a frequency synthesizer should be used at a cost of about \$4,000 per unit. The frequency synthesizer not only provides additional frequency agility for the SEET (if needed), but it can be controlled remotely through the UMSTEAD. Although the synthesizer is not necessary, it does not take many frequency changes for the cost of crystal oscillators to exceed the cost of a synthesizer.

4.4.1 Amplitude Response Over Operating Bandwidth

The amplitude response of the entire transmit and receive chain over the entire 36 MHz band has been selected so that the channel power will be within the power level increments of the UMSTEAD modem (i. e., 1 dB). Thus, the power setting of a channel need not be changed as the channel frequency is changed. The amplitude response over any 25 kHz SCPC channel, 1.5 MHz band or any 3.1 MHz band will not degrade the channel if the amplitude response over any 36 MHz band is less than or equal to ± 0.5 dB.

4.4.2 Phase Linearity Over Operating Bandwidth

To limit the loss due to departures from linear phase versus frequency to less than 0.5 dB, the nonlinear component of the delay must be kept to less than one-tenth

of a pulse width. If half of this value is budgeted to each terminal in a link, then the delay must be less than $\pm 3 \mu\text{sec}$ for a 16-kbps channel and $\pm 30 \text{ nsec}$ for a 1.5 mbps channel. For the 16-kbps channel operating over a 25 kHz band, this delay is also expressed as a phase departure from linearity of ± 0.25 radian; for 1.5 mbps operating over 3.1 MHz, ± 0.32 radian; and for 1.5 mbps operating over 1.5 MHz, ± 0.16 radian.

4.5 SPECTRAL PURITY

The UMSTEAD will produce an uplink signal at IF which contains spurious and harmonic output levels which are greater than 40 dB below each single carrier. The uplink chain (from IF through all RF equipment) and the downlink chain (through all RF equipment to the IF interface with the UMSTEAD) should not degrade this 40 dB level by more than 3 dB. This includes spurious signals, crosstalk between transmitter and receiver, and other sources of noise in the system which might occur when the system is driven with up to six 25 kHz carriers located in any 36 MHz band and two CW carriers anywhere in the 500 MHz band. This spectral purity must be maintained when the terminal is operating the specified EIRP.

4.6 FREQUENCY STABILITY

The UMSTEAD provides AFC which can be controlled and set by the network control terminal. Pilot tones are also generated by the terminal so that frequency correction for various translation errors can be accomplished. This allows the frequency stability of the SEET to be relaxed below that needed for the DSCS. The UMSTEAD is designed to operate through commercial terminals and satellites. Specifications for the commercial terminals allow a frequency tolerance of $\pm 150 \text{ kHz}$ for telephone carriers over a period of one month. This represents an error of $\pm 2 \times 10^{-5}$ parts per month. However, frequency stabilities on the order of one part in 10^8 per day and one part in 10^7 per month are easily obtainable with ordinary crystals. Thus, these numbers will be used for the stability requirements of the SEET.

4.7 GAIN OF TRANSMIT AND RECEIVE CHAINS

The gain of the transmit chain is defined by the EIRP of the terminal and the output level of the UMSTEAD. The 70 MHz UMSTEAD output is no greater than -25 dBm per carrier or no greater than -12 dBm for the composite signal. In addition, the EIRP for one 32-kbps voice link is approximately 69 dBw. Thus, a transmit gain of 124 dB is required.

The receive chain shall have sufficient gain to produce receive levels at the IF interface of -34 to -44 dBm per carrier. Received signal levels at the output of the antenna are expected to be -147 dBw per carrier. This thus requires a receive gain of 78 dB.

4.8 ANTENNA TRACKING

Because the present DSCS satellites operate in a window of 6° (North-South) by 2° (East-West) and the North-South motion repeats every 24 hours, the G/T requirement cannot be met without some antenna tracking capability. No restriction on the type of tracking should be imposed upon the contractor. However, the contractor must demonstrate that both the EIRP and G/T requirements are met while the satellite drifts. The contractor must also show that the methods employed are both cost effective and satisfy the reliability and maintainability concepts of the SEET. It is anticipated that the contractor will select a step-tracking technique principally to save the cost of a tracking feed. According to industry sources, it is expected that the SEET antenna and tracking requirement can be satisfied at a cost of \$65,000. This includes the cost of the reflector, feed, pedestal, and all tracking controls, and electronics. This configuration allows a binary readout of the antenna pointing angles so that this data can be relayed over the orderwire and displayed at the NCT if desired.

The area of coverage for the antenna system is assumed to be any 10° by 10° segment of the upper hemisphere. For a particular SEET site, the nominal pointing angles will be defined. Operations lower than an elevation angle of 5° are excluded.

The cost of the foundation for the pedestal and site preparation are not considered as part of the cost of the SEET.

It is recommended that the tracking subsystem be designed such that a special down converter need not be employed to serve the tracking receiver. One possible technique is to employ an energy tracking subsystem where the power radiated by the satellite over a wide band is detected in an energy detector of sufficient bandwidth to provide smoothing of the rapid fluctuations in the signal. Industry sources have reported tracking the DSCS and NATO satellites without difficulty. A terminal with a G/T of 34 dB can track a satellite while measuring a Y-factor of 0.3 dB. Here, the Y-factor is defined as the ratio of the noise experienced while the terminal is pointed at the satellite and the noise experienced when the terminal is pointed at the background sky. Although a G/T of 22 dB cannot track noise levels this low, any satellite channel which radiates 1-watt in any 36 MHz band will provide sufficient signal levels for tracking. This 1-watt can be expressed in terms of a power density at the terminal of $-216 \text{ dBw/Hz/meter}^2$.

4.9 AM/PM CONVERSION

The terminal will operate in an environment of carriers being turned on or off at random. Of particular concern is the transmission of a pollback message to the network control terminal during a period when one or more of the 32-kbps voice carriers is being turned on or off. During these periods, large changes in the total output will be experienced (on the order of 10 dB or larger).

The very minimum AM/PM conversion in the transmitter chain is approximately 6 degrees/dB due to the transmitter tube itself. With such large changes in carrier level, even these small AM/PM conversions become significant. The loss experienced due to AM/PM conversion is given by

$$\text{Loss (dB)} = 20 \log [\cos (\phi)] \quad (4-7)$$

where ϕ is the phase error. Even when the AM/PM conversion is 6°/dB and a 10 dB change is experienced, the phase error (if the bit synchronizer cannot track the error)

is equal to 60° and the loss is 6 dB. However, it does not appear attractive to attempt to restrict the designer of the SEET to very small values of AM/PM. Rather it seems more attractive to leave the designer a very relaxed specification (such as $30^\circ/\text{dB}$ for the transmit chain and $10^\circ/\text{dB}$ for the receive chain) and to restrict the rate at which carrier levels are allowed to change so that the bit synchronizer tracking loops will be able to follow the shift in phase. It appears that the design of the UMSTEAD modem has accomplished this, since limited testing of the UMSTEAD in a small tactical terminal has been accomplished without noting any AM/PM problems. However, this is an area which needs to be watched during the SEET development cycle.

4.10 RELIABILITY AND MAINTAINABILITY

The SEET equipment will be located in a fixed-plant adjacent to other electronic equipments which support terrestrial communications networks. These terrestrial equipments will be operated and maintained by full-time personnel with the equivalent of an Army Military Occupational Specialty (MOS) Code 26V. The monitor subsystem should indicate faults down to the level of a replaceable module. When a fault occurs, a light on the front panel of the failed unit will light and an audible alarm will sound. Maintenance personnel responding to the alarm will simply replace the indicated module with a stand-by unit and wait for the fault subsystem to automatically be restored. This operation is expected to require an average of 15 minutes from a fault occurring and the fault being cleared.

There will be some faults which cannot be cleared by simple substitution of modules. In this event, it is anticipated that the on-site maintenance personnel will place an emergency call for other maintenance personnel who are specially trained to maintain SEET equipment (MOS 26Y). In this event, it is anticipated that a 24 hour travel period and a 24 hour repair period occur before the fault can be cleared. If 80 percent of the faults average 15 minutes to repair and 20 percent average 48 hours to repair, the Mean Time To Repair (MTTR) will be 9.8 hours.

According to industry sources, the reliability of typical small terminal components is as presented in Table 4-6. The first redundant configuration listed in

Table 4-6. Reliability of a Small Terminal

	Failure Rates ($\times 10^6$)		
	Single Thread	Redundant Configuration No. 1	Redundant Configuration No. 2
Antenna	10	10	10
LNA	40	40	40
RF Line Amplifier	10	10	10
Down Converter	56	56	56
Up Converter	59	59	59
Crystal Oscillator	15.5	15.5	15.5
Crystal Oscillator	15.5	15.5	15.5
Modem	200	NEG	NEG
Waveguide, RF Dist. & RF Combiner	8.5	8.5	8.5
HPA	111	111	NEG
Tracking Receiver, Logic & Servos	96	96	NEG
Total Failure Rate ($\times 10^6$)	621.5	421.5	214.5
MTBF	1,609 hrs	2,372 hrs	4,662 hrs
MTTR	9.8 hrs	9.8 hrs	9.8 hrs
Avallability	.9939	.9961	.9979

this table parallels only the modem. The second configuration parallels both the modem, the High Power Amplifier (HPA), and the tracking subsystem.

It should be noted that an MTBF of 3638 hours and 20 percent failures which require an emergency trip to a terminal by a terminal specialist implies that an emergency trip will occur less than once per year. Other trips to terminals periodically for preventive maintenance and terminal testing by the specialist are suggested.

4.11 COSTS

A possible configuration for the SEET is shown in Figure 4-3. Table 4-7 presents projected costs both for single-thread and for the redundant configurations described above.

As can be seen from Table 4-7, the cost of the single-thread version of the SEET is slightly above the goal of \$250,000. However, it is anticipated that a large-scale procurement of SEET's would reduce the per terminal cost to be within this goal.

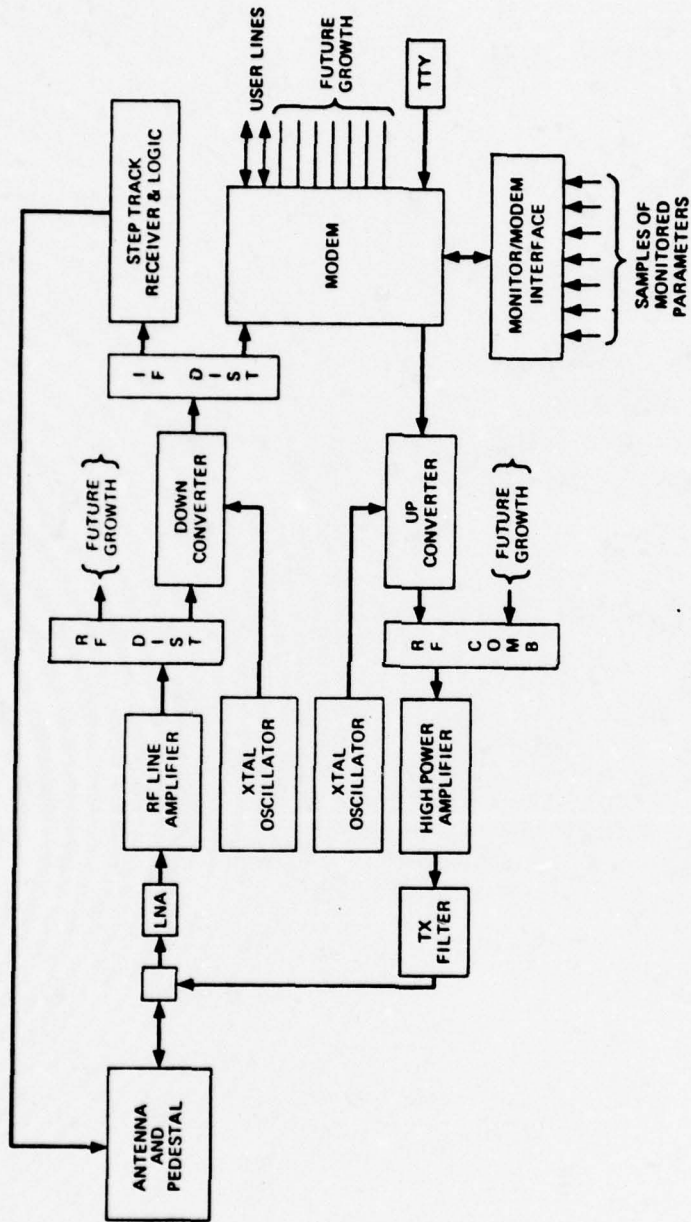

Figure 4-3. Possible Configuration of SEET

Table 4-7. Projected SEET Production Costs

Item	Single Thread	Configuration No. 1	Configuration No. 2
15' Antenna & Limited-Motion Pedestal	\$ 48,000	\$ 48,000	\$ 48,000
Drive Motors	3,000	3,000	6,000
Step Track Receivers & Logic	14,000	14,000	28,000
FET Low-Noise Amplifiers	5,000	5,000	5,000
320 Watt Transmitter	30,000	30,000	60,000
RF Line Amplifier	7,000	7,000	7,000
Up Converter	18,000	18,000	18,000
Down Converter	14,000	14,000	14,000
Crystal Oscillators (2)	1,200	1,200	1,200
UMSTEAD Modem	55,000	110,000	110,000
Monitor/Modem Interface	<u>9,000</u>	<u>9,000</u>	<u>9,000</u>
	\$204,200	\$259,200	\$306,200
13 percent Material Burden	<u>26,500</u>	<u>33,700</u>	<u>39,800</u>
	\$230,700	\$292,900	\$346,000
14 percent System Integration	<u>32,300</u>	<u>41,000</u>	<u>48,400</u>
	\$263,000	\$333,900	\$394,400

SECTION 5 - SUPPORT AND ACQUISITION CONSIDERATIONS

5.1 INTRODUCTION

Up to now, this report has dealt mainly with the technical characteristics of the SEET. However, other important aspects of the SEET which can have a significant impact on cost are its support and acquisition procedures.

This section discusses support and acquisition considerations for the development and procurement of the SEET. Significant factors in these areas include:

1. Emphasis on low production cost
2. Use of commercial off-the-shelf items and technology
3. Worldwide deployment
4. 15-year life cycle.

Highlighted in this section are factors to be considered relating to:

1. The Operation and Maintenance Concept
2. Logistic Support Factors
3. Statement of Work
4. Contract Data Requirements List.

5.2 OPERATION AND MAINTENANCE CONCEPT

5.2.1 Operation

The SEET will be located and operated in an existing fixed-plant facility adjacent to other electronic equipments supporting terrestrial communication links. The SEET will operate unattended under full-time control of a central controller located at a large satellite communications terminal somewhere within the satellite visibility area. Communication between this control terminal and all SEETs operating through a particular satellite shall be via a full-time orderwire supported by the satellite. No links are established to support users until the user picks up an appropriate telephone and

dials a number. This act allows the SEET network of terminals and the central controller to identify the receiving terminal, assign RF frequencies and power levels, and to establish an RF full-duplex link in support of the user. When the user hangs up the telephone, the RF carriers are removed and the link is deactivated.

5.2.2 Maintenance

The SEET will be fully automated with built-in system test circuitry, status/fault indicators, and audible alarms. Modular design and construction will be emphasized and each module which can be replaced in the event of fault/failure will have an indicator light readily apparent on a front panel. Except for routine preventive maintenance, module substitution to clear faults and the simplest of emergency repairs and adjustments no other maintenance will be performed at the terminal. Intermediate level maintenance will be performed by mobile teams. Depot maintenance will be performed by the manufacturer until such time as the Military Departments can assume this responsibility. Alternatively, depot maintenance may be performed by a contractor. If the UMSTEAD Modem, a key SEET component developed by NSA, is selected, special arrangements may be required with NSA to coordinate maintenance activities.

5.3 LOGISTIC SUPPORT FACTORS

5.3.1 Maintenance

1. Organizational Level Maintenance
 - a. Action by the user consists solely of activating the terminal (raising the telephone handset and dialing).
 - b. Extensive built-in test equipment (BITE) including system status/fault indicators, audible alarms, and modular construction will permit the substitution of plug-in units to clear faults. This effort will be performed by existing on-site personnel (MOS-26V or equivalent skill). No special training will be required.

2. Intermediate Level Maintenance

Design and performance standards will require periodic preventive maintenance to test and trigger automatic built-in test equipment and to perform simple diagnoses, repairs and minor adjustments. This maintenance will be performed on a routine periodic basis or on call by mobile teams (MOS-26Y or equivalent skill with minimal additional training required). Additional personnel required--to be determined.

3. Depot Level Maintenance

This level maintenance will require shop facilities, personnel, and skills not available in the field and will consist of modular disassembly, repair or replacement of parts, reassembly and test. Upon satisfactory completion of test, the modules are returned to stock or to site. Two basic options exist for performance of this effort. In order of preference:

- a. Depot level maintenance performed by the contractor at his facility. (This will eliminate the requirement to establish a complete military parts supply system, to establish a military depot facility, and to train military or civilian repair technicians). This effort might be performed under a conventional type contract or under a contract containing service and warranty provisions. For a brief discussion of warranty considerations, see Attachment A.
- b. Depot maintenance performed in a military depot (to be established/designated). A complete military supply system for SEET parts and modules will be established. Number of military/civilian technicians and training required--to be determined. Support and test equipment required for depot maintenance--to be determined.

5.3.2 Supply

The SEET maintenance concept determines the supply posture for parts and modules excluding the major item itself.

1. Organizational Level Supply

Basic on-hand stock of replacement modules--quantity to be determined.

2. Intermediate Level Supply

Basic on-hand stock of electrical items, antenna parts, modules and test equipment for use by mobile maintenance teams for preventive maintenance, diagnosis and emergency minor repairs and alignment will be required. Items and quantity--to be determined.

3. Depot Level Supply

The two basic options, related to military vs contractor depot maintenance, in order of estimated cost from the parts supply standpoint (more costly listed first):

- a. Military Depot Maintenance. If SEET depot (factory rebuilt type) maintenance will be performed by the Military Departments, a complete provisioning of SEET parts, modules, and support and test equipment will be required in the military supply system(s). A justification used in the past for this expense has been that it avoids the Military Departments being forced into a sole source procurement position with its attendant additional expense. However, if an objective is to reduce costs through the use of commercial parts, this option tends to place the Government in the position of dictating to a vendor what his commercial part make-up will be. This is not practical since vendors procure and stock against demand or anticipated demand.

- b. Contractor Depot Maintenance. If SEET depot maintenance will be performed by the contractor in his facility, there would be no requirement for complete military parts provisioning and stockage. Use of commercial piece parts would be abetted. Military supply systems would stock modules only. The burden of parts control would fall on the contractor (the Government pays in the end). This option opens the door for another deviation from the supply norm. Since there would be no module repair/rebuild in the military system, and since module requirements would be reasonably predictable at specific known locations, considerations should be given to eliminating even the SEET modules from the military supply system with a direct exchange (faulty for rebuilt) between the user site and the depot. This latter deviation would also mesh with contract warranty provisions.

5.3.3 Training

Training requirements are based on user/operator and maintenance considerations and are as follows:

1. User/Operator Training

The SEET will be operated by the user by raising a telephone hand set and dialing a number. A full time operator is not required. Net control of user communications will be performed by existing personnel from a central controller. There is no military training requirement for the user.

2. Maintenance Training

- a. Organizational Level Maintenance. Module replacement. Minimal on-the-job military training; no special training required. (Existing on-site personnel, MOS-26V or equivalent skill.)

- b. Intermediate Level Maintenance. Periodic Preventive Maintenance-- Mobile Team Concept. Minimal additional military training will be required if performed by military personnel, MOS-26Y or equivalent skill. No training required if performed by contractor.
- c. Depot Level Maintenance. If performed by military (or civil service) technicians, extensive initial and continuing replacement military training will be required. This would entail initial military instructor training by the contractor followed by the establishment of a complete course of military training covering SEET module tear-down, diagnosis, repair, rebuild, and test. There would be no military training requirement if depot maintenance is performed by the contractor. Because of the nature of the UMSTEAD Modem, depot maintenance training for this item will be handled on a selective/restricted basis in accordance with NSA requirements.

5.3.4 Transportation, Packing and Handling

The SEET, its modules and piece parts will be fabricated and packed to normal commercial transportation and handling specifications for their respective global destinations. The terminal may be moved from fixed site to fixed site up to five times during its 15-year life cycle. Disassembly of the terminal and packing in its transportable configuration should require no more than 7 days. Unpacking and reassembly for operation should require no more than 14 days. Transportation will be by land, sea or C-141 type aircraft. Either the Government or the contractor could be responsible for disassembly, packing, movement, unpacking and reassembly including repair/replacement during this period.

Transportation will be required by mobile maintenance teams to perform their intermediate maintenance mission. Normally, ground transportation should suffice; however, mobile teams may require air transportation to remote or isolated terminal sites. Sufficient transportation should be dedicated to permit immediate response to requests for emergency service. Quantity, type, and location of transportation--to be determined.

5.3.5 Documentation

Documentation such as provisioning data and technical manuals will be commensurate with the minimum requirements imposed by the approved maintenance concept and corresponding requirements for training. Technical manuals will follow commercial formats and content to the maximum extent possible. However, if depot maintenance will be a Military Department responsibility, documentation required for maintenance and maintenance training must meet military standards and formats. All logistic support documentation requirements will be carefully screened to ensure that minimum requirements are placed upon the contractor.

5.3.6 Logistic Support and Associated Facilities

With the exception of depot maintenance facilities, existing military department supply, storage and issue facilities will be used for the SEET. Actual space required will depend on the approved maintenance concept and the corresponding supply concept previously outlined. If the military departments are to provide depot maintenance, facilities will be designated. If the contractor is to provide depot maintenance, he will furnish his own facilities. The requirements for military training and associated training facilities will be minimal unless the Military Departments assume responsibility for all maintenance and its concomitant supply requirements. Final facility requirements will depend on maintenance concept, supply posture, extent of SEET deployment, and the requirements for military training.

5.4 STATEMENT OF WORK (SOW)

In the acquisition of the SEET, it is understood that requirements for terminal hardware, the integration of CFE/GFE, and the quality assurance provisions to be reasonably certain of compliance with those requirements, must be included in the SEET specification. In a procurement such as SEET, it is also necessary for the Government to place requirements on the contractor for work he must perform in such areas as program management, engineering management, configuration management,

reliability/maintainability programs, and integrated logistic support. The vehicle for specifying such tasks is the SOW. The following paragraphs address factors to be considered in preparing the SOW for SEET:

- 1.0 Scope. SEET system description, including UMSTEAD Modem; emphasize economy, commercial components, and technology for development and production.

- 2.0 Applicable Documents. Include documents applicable to requirements of the SOW; however, it must be emphasized that one of the primary objectives in the SEET procurement is to obtain an economical earth terminal using off-the-shelf commercial components and technology. Overapplication of specifications and standards is costly. ASPR 1-1201 specifically requires that referenced specifications and standards be tailored so that only minimum needs of the Government are imposed as requirements. Improper application of specifications and standards could lead to the procurement of a terminal which would operate under the most severe conditions which is not required. Failure to tailor specifications and standards quickly mushrooms with a Christmas tree effect, for example: MIL-E-4158E (Electronic Equipment Ground: General Requirements For), references two Federal Specifications, 14 military specifications, eight military standards and two AFSC Design Handbooks. Just one of the referenced military standards, MIL-STD-891B, Contractor Parts Control and Standardization Program, references an additional 10 military standards, five military specifications, one military handbook and one DOD manual. Tailoring can be accomplished by citing specific requirements in references that apply or do not apply, by providing or extracting detailed requirements and/or by restricting data item requirements to those which are essential.

- 3.0 Requirements.
- 3.1 Test and Test Support Programs. Test and test support and inspection programs will be required to verify the capability of the equipment to interface with the UMSTEAD Modem (GFE); to perform as a system; to verify quality assurance requirements; and, to comply with any other test requirements that may be required by the specification.
- 3.2 Specifications. Product specifications will be required upon completion of development and testing so that the SEET baseline for production models can be established.
- 3.3 Engineering Drawings. Engineering drawings will be required as interface control documentation in sufficient detail to enable evaluation and control of the physical and functional interfaces of SEET system. Particular emphasis will be placed on the description of the electrical and mechanical interfaces among the components of the SEET system.
- 3.4 Program and Engineering Management. The contractor's management systems should provide the Government with a clear picture as to how the contractor proposes to manage and control the program. An extended Contract Work Breakdown Structure (CWBS) could be required. Program control should provide periodic correlated measurements of cost, schedule and performance related to the program budget and plan.
- 3.5 Program and Technical Reviews. Program reviews (status to include cost, schedule, and performance) and technical reviews (System Design Reviews (SDR), Preliminary Design Reviews (PDR) and Critical Design Reviews (CDR)) will be required throughout the contract. Program reviews should highlight progress, deviations or variances and corrective actions. Technical reviews (SDRs, PDRs, CDRs) are technical assessments of system engineering and design efforts; are major contract milestones; and, are scheduled to support key decisions by

the Government. Government approval and acceptance of each formal review is required. Design documentation presented at a CDR, once audited and accepted becomes the allocated baseline. Changes must be implemented through configuration management procedures.

3.6 Cost Effectiveness Analysis. A least cost of ownership program with a 15-year life cycle will be required to ensure the development of the most cost-effective equipment design. The objective of this program is the successful development of a SEET that can be produced and operated at the least cost of ownership.

3.6.1 Unit Production Cost (UPC) Program. The Government will establish a UPC target for the SEET. The UPC target establishes cost as a design parameter during the design and development phase. The contractor's UPC program will allocate cost targets during design, track unit production costs estimates and analyze, functionally, areas of high cost or areas exceeding target cost during development.

3.6.2 Life Cycle Cost (LCC) Program. The contractor will conduct an LCC program to predict the total cost to the Government of acquisition and ownership of the equipment over its full life span (15 years). LCC includes the cost of development, acquisition, operation and support. The contractor should establish an LCC model tailored to the requirements of the SEET program and estimate costs by respective cost elements of the program and by fiscal year over the entire program life cycle. Proposed engineering changes must include an analysis of the effect of the change on development costs, unit production costs, total investment costs and annual operating and support costs.

- 3.7 Configuration Management (CM)
- 3.7.1 Configuration Management Plan. Configuration management will be required for SEET to the extent that a configuration identification can be established to permit subsequent configuration control, audits, and configuration status accounting. Consequently, consideration should be given to specifying (as a CDRL item) a CM plan which will describe the necessary contractor CM procedures required to produce the desired SEET configuration. A plan, similar to the CM plan described in Appendix I of MIL-STD-483 could be specified. However, the CM plan should be tailored, i. e., only those essential MIL-STD-483 requirements should be specified thereby avoiding costly imposition of unneeded requirements.
- 3.7.2 Configuration Identification. The approved technical documentation, such as specifications and drawings, constitute the configuration identification for the SEET.
- 3.7.2.1 Functional Baseline. The functional baseline is the initial approved configuration baseline. The current description of the SEET, i. e., its functional baseline could be documented by the contractor by updating the system specification of the SEET using commercial equipment.
- 3.7.2.2 Product Baseline. The product baseline establishes the design from which the SEET hardware will be fabricated. The product baseline could be documented by the SEET product specification and interface control drawings (ICDs) describing the interface among contractor off-the-shelf items, GFE, and BITE.
- 3.7.3 Configuration Control. In establishing and maintaining configuration control during development and production of the SEET, consideration should be given to use of the contractor's own configuration management procedures (which can be documented in a CM plan, see paragraph 3.7.1

above) in place of invoking costly Government CM standards, e. g. , MIL-STD-480. The contractor CM plan to be submitted and approved by the Government should contain the necessary procedures to ensure that engineering changes to the SEET will be reviewed by the Government to assess impact on the GFE (UMSTEAD Modem, e. g.).

A section in the CM plan should be included to cover configuration control once SEET has entered the operational phase. Coverage must be provided for those engineering changes required, e. g. , to correct design deficiencies found during joint Government-Contractor review and analysis of SEET performance data.

3.7.4 Configuration Audits

3.7.4.1 General. A functional configuration audit (FCA) and a physical configuration audit (PCA) will be required to permit examination of contractor progress in developing SEET. Procedures for the FCA and PCA can be tailored for SEET, using MIL-STD-1521, e. g. , as a guideline and documented as part of the contractor CM plan.

3.7.4.2 Functional Configuration Audit (FCA). The FCA should be conducted to verify that the actual performance of SEET complies with its product specification. Test data should be reviewed to confirm that the SEET has performed as required by its functional configuration identification.

3.7.4.3 Physical Configuration Audit (PCA). The PCA should verify that the SEET has been built in accordance with the approved engineering drawings, specifications, and technical data describing the SEET design.

3.7.5 Configuration Status Accounting. Although status accounting should be required of the contractor, limited reporting and latitude in the method of status accounting could reduce costs. Off-the-shelf items should require less frequent status accounting reports due to fewer engineering changes required.

- 3.8 Integrated Logistics Support (ILS) Program. The contractor will establish and maintain an ILS program to ensure that logistic support of the SEET will be planned and provided in an integrated and systematic manner and that logistics considerations are incorporated in system design. The objective is to enable the SEET to meet all the requirements imposed by the specification at the lowest predicted LCC within the limitations and constraints of the Government's operation and maintenance concepts.
- 3.8.1 ILS Management Support. The contractor will provide support to the procuring activity and to other Government agencies or contractors, as required to accomplish ILS requirements for the SEET.
- 3.8.2 Spare and Repair Parts/Modules. The contractor will determine spare and repair parts/modules for organizational and intermediate levels of maintenance to support each SEET for ___ hours of operation. Parts/modules recommended will be those to accompany the equipment. Consideration in the selection/recommendation process will be given to the maintenance concept, item MTBF, essentiality of the item, cost and time required for replacement, weight and volume storage requirements, and depot repairability. The contractor will be responsible for the replenishment of spares consumed during testing and reliability/maintainability demonstrations.
- 3.8.3 Contractor Maintenance Support. The contractor will establish a maintenance capability (depot level) to inspect, analyze and repair as necessary modules returned as inoperable for a period of 1 year or as otherwise specified in the contract. Modules will be repaired and returned to a location specified by the procuring activity within ten days from receipt. A failure analysis will be conducted on each failed unit.

- 3.8.4 Technical Publications. The contractor will develop an operation and maintenance user's manual. The manual will include basic design information, operational procedures, BITE data and logistic support information in accordance with applicable quality assurance provisions.
- 3.9 Reliability Program. The contractor will establish a reliability program which is tailored to the reliability requirements of the specification. The program shall be implemented as an integral part of the total development, fabricating and testing process. The contractor will evaluate the predictions with respect to the reliability expected from a production unit. If there is a discrepancy between the predicted MTBF and required MTBF, the contractor will identify the causes of the discrepancies and indicate action required to assure that the inherent reliability of the equipment is preserved during the production process.
- 3.10 Maintainability Program. The contractor will establish and implement a maintainability program to ensure that maintainability engineering is involved in all facets of development, testing and manufacturing to ensure that the quantitative maintainability requirements are met. The maintainability prediction will include BITE as an integral part of the equipment. The prediction will be prepared in two parts. Part I will be performed for the replacement of modules at the organizational level of maintenance. Part II will be accomplished by the replacement of piece parts at the depot level of maintenance. Where predicted values do not achieve requirements, the contractor will accomplish such changes in design to achieve the requirements.
- 3.10.1 Analysis of BITE Detection and Isolation Capability. The contractor will maintain a record of all failures that occur on assembled equipment during all Quality Conformance Inspections throughout the dura-

tion of the contract. At each occurrence of equipment failure or malfunction, the BITE shall be exercised and compliance or noncompliance with the specification requirements for fault detection and isolation shall be recorded. The contractor shall analyze the data collected and maintain a summary of the BITE detection and fault isolation capabilities.

- 3.11 Electromagnetic Compatibility (EMC) Program. The contractor will establish an EMC program to the extent necessary to ensure compliance with the Electromagnetic Interference requirements of the specification and will include Electromagnetic Interference (EMI) control planning, EMI/EMC test planning and testing. Guidelines for development of the EMC Program Plan are provided in MIL-HDBK-237.
- 3.12 TEMPEST Control Program. The contractor will establish a TEMPEST control program, if applicable, to organize the contractor's efforts to ensure compliance with the TEMPEST requirements of the Specification.
- 3.13 System Safety Program. The contractor will establish a system safety program to comply with the "Engineering Development Phase" requirements of MIL-STD-882 to the extent specified herein. Safety design criteria and engineering designs should be reviewed by the contractor to ensure compliance with the requirements and specification. The criteria should comply with the "System Safety Criteria and Considerations" requirement of MIL-STD-882. All safety criteria will be identified in a system safety checklist. The contractor should perform qualitative analyses to identify hazardous conditions in accordance with the "Preliminary Hazard Analyses" requirement of MIL-STD-882. The potential hazards identified shall be included in the system safety checklist as appropriate. The checklist will be

used to control or eliminate hazards in the equipment. The contractor should ensure that safety verification is included in his test program. Upon the request of the procuring activity, contractor safety personnel will participate in design reviews. Safety program planning will be conducted to ensure compliance with these requirements.

- 3.14 Human Engineering Program. An integrated human engineering program should be conducted by the contractor throughout equipment development to ensure that human engineering principles are applied to the development of man-equipment interfaces and operation/maintenance procedures in accordance with MIL-H-46855 to the extent specified herein. The contractor's effort will define and allocate systems functions in accordance with the "defining and allocating system functions" requirement of MIL-H-46855. The contractor's program should comply with the "failure analysis" and "drawing approval" requirements of MIL-H-46855. Program planning should demonstrate the methodology for compliance with the above requirements and the "controls, indicators and panel layouts" requirement of the specification. This methodology will include the scheduling of human engineering tests. If off-the-shelf equipment is to be used, the program should indicate which human engineering requirements require a waiver.
- 3.15 Training. The contractor will prepare and present introductory/orientation training for military department personnel covering organizational operation and maintenance.
- 3.16 Quality Program. The contractor will establish and maintain a quality program for supplies and services in accordance with MIL-Q-9858. The contractor should plan the individual efforts of the quality program, tailoring them to the specific features of the SEET.

These quality assurance efforts will be documented in a Quality Assurance Plan and maintained current with the program schedule, highlighting significant Quality Assurance decisions, tasks, and assigned responsibilities relating to this contract.

5.5 CONTRACT DATA REQUIREMENTS LIST (CDRL)

Requirements for data items such as drawings, plans and reports to be prepared by the contractor for delivery to the Government must be specified in the CDRL (DD Form 1423). The manhours expended by a contractor in preparing data items and the Government work load associated with data management, and the review, analysis, approval and dissemination of such data can be very costly. Therefore, careful consideration should be given to data item requirements in the SEET procurement. The concept of procuring off-the-shelf items combined with unique logistic support requirements will alleviate the need for many data items that have been requested in previous earth terminal procurements. Overzealous development of the CDRL will detract materially from the design, development, and fabrication of an economical earth terminal. All data item requirements must be carefully screened to ensure that both management control and technical reports are reduced to the minimum levels needed to successfully complete the program. Acceptance of some commercial off-the-shelf documentation may assist in alleviating the expense. The following are examples of data items that should be specified in the SEET contract:

1. Test plan (covering tests and demonstrations to be conducted by the contractor and monitored by the Government)
2. Specifications (Type C, "build-to" specifications describing or identifying the commercial items and integration of CFE/GFE to a level of detail that would permit a competitive solicitation for production of SEETs in quantity)
3. Drawings (MIL-STD-100B and MIL-D-1000A drawings for the system but not for each component)

4. CWBS (Include a basic WBS in the RFP and ask the contractor to expand it to cover a specific level of detail)
5. Management Plan (The contractor's plan for controlling cost, performance, and schedule)
6. Technical Review Reports (Documentation of results of design reviews)
7. Cost Effectiveness Analysis Report (Contractor's predicted costs per SEET and Life-Cycle Cost)
8. Configuration Management (CM) Plan (A CM plan covering the contractor's proposed actions relating to configuration identification, control, status accounting, and audits)
9. Integrated Logistic Support Plan (Covering the contractor's internal procedures for ensuring that logistic support analysis is an integral part of the SEET design. It would also include his procedures for providing spares and repair parts with each SEET)
10. Technical Publication (Technical publication should include manufacturer's manuals for commercial items, a user's manual for operation and a system manual for the complete SEET configuration)
11. Training Plan (A plan covering orientation of MILDEP instructor personnel at the contractor's plant).

SECTION 6 - CONCLUSIONS

This report has described a network of small economical earth terminals which could be procured for use in the Defense Satellite Communications System in the early 1980's. Based on the current trend in commercial earth terminals, these DSCS earth terminals would be small, relatively inexpensive (under \$250,000), and would stress fixed plant location and unattended operation. The technical characteristics which appear to provide the most performance within the cost limitations of the SEET are a G/T of 22 dB/K and an EIRP of 72 dBw. These parameters could be obtained by using a 15 foot diameter antenna, an FET low-noise receiver, and a transmitter of approximately 320 watts.

Additional features of the SEET, such as single-channel-per-carrier operation and control by a network control terminal are also feasible and are obtainable with existing modems. In addition, the parameters of the SEET have been chosen so that the terminal is compatible with all three phases of DSCS satellites - DSCS II, DSCS IIa, and DSCS III.

The report has also presented a brief discussion of items which should be considered in the procurement of the SEET. It has pointed out that particular emphasis should be given to requiring only those items which are actually needed in the procurement process and in operating and maintaining the terminal. Following past procurement practices, whether required or not, can only lead to increasing the cost of the SEET. Emphasis must be placed on the word "economical" during the entire procurement process.

Thus, it is concluded that a small economical earth terminal, as described, is technically feasible for use in the DSCS in the early 1980's and could be procured, in large quantities, within the cost constraints described.

ATTACHMENT A

Warranty Considerations

The following is an excerpt from Memorandum from the Assistant Secretary of Defense Installations and Logistics to the Secretaries of the Military Departments, dated August 14, 1974, subject: Trial Use of Reliability Improvement Warranties in the Acquisition Process of Electronic Systems Equipment:

"As part of the Department of Defense's effort to reduce costs and improve operational reliability of electronic systems and equipments, DOD requested that a trial application of warranties (now called Reliability Improvement Warranties (RIW)) be utilized in the acquisition process to help determine the scope and benefits that RIWs may have for the DOD. The objective of a RIW is to motivate and provide an incentive to contractors to design and produce equipment which will have low failure rates and low repair costs during field/operational use. This technique attempts, through the use of contractual agreements (which extend for several years after Government acceptance of the equipment), to provide an incentive for contractors to improve the reliability of the equipment and to reduce the repair costs in order to maximize their profits. Thus, the intent of the RIW contracting technique is to realize improved operational reliability and maintainability of DOD systems and equipments for each additional dollar that the contractor earns. For these reasons, an RIW is not a maintenance contract and therefore should not be used for this purpose... To realize the maximum potential from the use of RIWs, it is important not only to identify the good results but also to identify the problem areas so that the latter can be factored in and corrected in the Guidelines. Particular attention should be given to the collection of data so that accurate evaluation can be made of each program."

As outlined above, one of the contract options which should be considered is RIW. This technique has been used in procurements involving redesign of simple electronic equipments which have essentially been fielded such as the RADAR Altimeter, as well as for equipments under development such as the USAF's Omega Receiver and attitude-heading systems. It involves the establishment of cost per measure of utility upon which

contract award is based. The warranty would cover all field failures for an extended period of time. The buyer's and the seller's risk must be clearly identified and a firm fixed cost must be established. Rewards and penalties are shared. The contractor has the opportunity to increase his profit by improving performance while the customer also benefits from improved performance. An item failure penalizes the contractor and the customer suffers a drop in readiness. Reliability after acceptance as a result of field operation assumes an increased significance. The contractor has the opportunity to make improvements if they are cost-effective for him and will increase his profit. The customer benefits from a no cost ECP. The period of warranty coverage normally would be at least 3 years to include the initial years of the equipment's field performance. At the end of this time the Government might assess the RIW cost in terms of reliability and maintainability to determine if the warranty coverage should be continued. Should a routine maintenance service be desired from the contractor, the provisions for such should be separately stated in the contract and are not properly part of the warranty provisions.

There are negative aspects of this type warranty which also must be considered. A considerable price increase may be expected since the contractor is faced with setting a firm fixed cost over an extended period of time in the face of unknown future pricing factors. The customer is faced with establishing a long term contract which may tie him to equipment that may be overtaken and outperformed at less cost in a rapidly improving technology. Warranty variations covering either labor or parts should also be considered.