

AD-A053 733

BOEING AEROSPACE CO SEATTLE WASH
ADAPTIVE LANDING GEAR FOR IMPROVED TAXI PERFORMANCE. (U)
OCT 77 P T SOMM, H H STRAUB, J R KILNER

F/G 1/3

UNCLASSIFIED

D180-20795-1

AFFDL-TR-77-119

F33615-76-C-3004

NL

[of 1

AD
A053733



END
DATE
FILMED
6 -78
DDC

AD A 053733

AFFDL-TR-77-119

2
SC

**ADAPTIVE LANDING GEAR
FOR IMPROVED TAXI PERFORMANCE**

*BOEING AEROSPACE COMPANY
P. O. BOX 3707
SEATTLE, WASHINGTON 98124*

OCTOBER 1977

DDC
RECEIVED
MAY 9 1978
E

TECHNICAL REPORT AFFDL-TR-77-119
Final Report for Period January 1976 through August 1977

Approved for public release; distribution unlimited.

AIR FORCE FLIGHT DYNAMICS LABORATORY
AIR FORCE WRIGHT AERONAUTICAL LABORATORIES
AIR FORCE SYSTEMS COMMAND
WRIGHT-PATTERSON AIR FORCE BASE, OHIO 45433

DDC FILE COPY

NOTICE

When Government drawings, specifications, or other data are used for any purpose other than in connection with a definitely related Government procurement operation, the United States Government thereby incurs no responsibility nor any obligation whatsoever; and the fact that the government may have formulated, furnished, or in any way supplied the said drawings, specifications, or other data, is not to be regarded by implication or otherwise as in any manner licensing the holder or any other person or corporation, or conveying any rights or permission to manufacture, use, or sell any patented invention that may in any way be related thereto.

This report has been reviewed by the Information Office (OI) and is releasable to the National Technical Information Service (NTIS). At NTIS, it will be available to the general public, including foreign nations.

This technical report has been reviewed and is approved for publication.

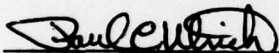

PAUL C. ULRICH
Project Engineer
Vehicle Equipment Division
Air Force Flight Dynamics Laboratory

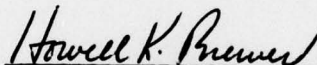

HOWELL K. BREWER, Chief
Mechanical Branch
Vehicle Equipment Division
Air Force Flight Dynamics Laboratory

FOR THE COMMANDER



AMBROSE B. NUTT, Director
Vehicle Equipment Division
Air Force Flight Dynamics Laboratory

"If your address has changed, if you wish to be removed from our mailing list, or if the addressee is no longer employed by your organization please notify _____, W-PAFB, OH 45433 to help us maintain a current mailing list".

Copies of this report should not be returned unless return is required by security considerations, contractual obligations, or notice on a specific document.

UNCLASSIFIED

SECURITY CLASSIFICATION OF THIS PAGE (When Data Entered)

19 REPORT DOCUMENTATION PAGE		READ INSTRUCTIONS BEFORE COMPLETING FORM	
1. REPORT NUMBER	2. GOVT ACCESSION NO.	3. RECIPIENT'S CATALOG NUMBER	
28 AFFDL TR-77-119			
4. TITLE (and Subtitle)	5. TYPE OF REPORT & PERIOD COVERED	9	
6 ADAPTIVE LANDING GEAR FOR IMPROVED TAXI PERFORMANCE	FINAL TECHNICAL REPORT JANUARY 1976-SEPTEMBER 1977		
7. AUTHOR(s)	8. CONTRACT OR GRANT NUMBER(s)	14	
10 P. T. SOMM, H. H. STRAUB, J. R. KILNER	D180-20795-1	25	
9. PERFORMING ORGANIZATION NAME AND ADDRESS	10. PROGRAM ELEMENT, PROJECT, TASK AREA & WORK UNIT NUMBERS		
THE BOEING AEROSPACE COMPANY SEATTLE, WASHINGTON 98124	Project No. 1369 Task No. 136901 Work Unit No. 13690151		
11. CONTROLLING OFFICE NAME AND ADDRESS	12. REPORT DATE	21	
AIR FORCE FLIGHT DYNAMICS LABORATORIES WRIGHT-PATTERSON AIR FORCE BASE, OHIO 45433	OCTOBER 1977		
14. MONITORING AGENCY NAME & ADDRESS (if different from Controlling Office)	13. NUMBER OF PAGES	12 71 p.	
	15. SECURITY CLASS. (of this report)	UNCLASSIFIED	
	15a. DECLASSIFICATION/DOWNGRADING SCHEDULE		
16. DISTRIBUTION STATEMENT (of this Report)			
APPROVED FOR PUBLIC RELEASE; DISTRIBUTION UNLIMITED			
17. DISTRIBUTION STATEMENT (of the abstract entered in Block 20, if different from Report)			
26 1369 27 QZ			
18. SUPPLEMENTARY NOTES			
19. KEY WORDS (Continue on reverse side if necessary and identify by block number)			
Landing gear, oleo, runway roughness, air chamber, hydraulic damping, taxi simulation, fatigue damage, dynamic gear load,			
20. ABSTRACT (Continue on reverse side if necessary and identify by block number)			
Taxi performance in terms of airplane CG acceleration for the KC-135, T-43A, and YC-14 type main gear are calculated with a digital simulation. Simple landing gear oleo modifications, such as bypass orifices and dual stage air chambers, are proposed and evaluated and reduce CG (RMS) acceleration by as much as 47%. Improved taxi performance also results in reduced gear loads when bomb crater repair patches are encountered with the KC-135 and YC-14 type gear. Fatigue damage due to taxi on austere fields decreases by 6% or more. However, fatigue damage due to taxi on prepared fields is not affected by the proposed oleo modification.			

DD FORM 1 JAN 73 1473 EDITION OF 1 NOV 65 IS OBSOLETE

SECURITY CLASSIFICATION OF THIS PAGE (When Data Entered)

159 614

hh

FOREWORD

This report was prepared by P. T. Somm, H. H. Straub, and J. R. Kilner of The Boeing Company, P. O. Box 3707, Seattle, Washington, 98124, under USAF Contract F33615-76-C-3004. The contract was initiated under Project No. 1369 "Development of Adaptive Landing Gear Systems For Military Aircraft Evaluation," Task No. 136901, the work was conducted under the direction of the Vehicle Equipment Division, Air Force Flight Dynamics Laboratory, Air Force Wright Aeronautical Laboratories, Wright-Patterson Air Force Base, Ohio, K. Schwartz and P. Ulrich (AFFDL/FEM), project engineers. All work related to this effort was carried out between January 1976 and August 1977. The Final Report was submitted in September 1977.

The authors are indebted to C. Larkins and T. C. Taylor of BMAD Structures Staff, Boeing Aerospace Company, for conducting the comparative Fatigue Analysis with the YC-14 type landing gear.

ACCESSION for	
NTIS	White Section <input checked="" type="checkbox"/>
DDC	Buff Section <input type="checkbox"/>
UNANNOUNCED	<input type="checkbox"/>
JUSTIFICATION.....	
BY.....	
DISTRIBUTION/AVAILABILITY CODES	
Dist.	AVAIL. and/or SPECIAL
A	

PRECEDING PAGE BLANK-NOT FILMED

TABLE OF CONTENTS

	PAGE
1.0 INTRODUCTION	1
2.0 METHOD OF ANALYSIS	3
2.1 Airplane Models	3
2.2 The Runway Model	6
2.3 Carpet Plots	6
2.4 Operating Conditions	9
3.0 RESULTS OF ANALYSIS	12
3.1 Data Presentation	12
3.2 YC-14 Gear Optimization	13
3.3 YC-14 Nose Gear Optimization	19
3.4 KC-135 Airplane	19
3.5 T-43A Airplane	22
3.6 KC-135 and T-43A Analysis Summary	22
4.0 HARDWARE IMPLEMENTATION - CONCEPTS	26
4.1 YC-14 Airplane	26
4.1.1 Fully Optimized Configuration	26
4.1.2 Dual Mode Damping Configuration	29
4.2 KC-135 Airplane	29
4.3 T-43A Airplane	31
5.0 PAY OFF ANALYSIS	36
5.1 Survivability	36

TABLE OF CONTENTS (Continued)

	PAGE
5.1.1 Simulated Conditions	36
5.1.2 Encounter with Repaired Bomb Damaged Runway	37
5.1.3 Encounter with Rectangular Bump and Dip	42
5.1.4 Encounter with Rutted Runway	45
5.2 Fatigue Analysis	48
5.2.1 Method	48
5.2.2 Results	49
6.0 CONCLUSIONS AND RECOMMENDATIONS	55

LIST OF FIGURES

FIGURE		PAGE
1	Numerical Method Used to Generate Random Runway	8
2	Shock Strut Load Paths	10
3	Definition of Air Curves	14
4	YC-14 Main Gear Parameter Variation, Landing Configuration	15
5	YC-14 Main Gear Parameter Variation, Taxi on Unprepared Field	16
6	YC-14 Main Gear Parameter Variation, Landing Configuration	17
7	YC-14 Performance Summary ALG on Random Runway	18
8	YC-14 Nose Gear Parameter Variation, Landing Configuration	20
9	KC-135 Main Gear Parameter Variation, Max. Weight Take-off	21
10	T-43A Main Gear Parameter Variation, Paved Field	23
11	KC-135 and T-43A Analysis Summary	24
12	Typical Control and Sequencing Logic for Fully Optimized ALG	27
13	ALG Concept Configuration for YC-14, Fully Optimized	28
14	Adaptive Landing Gear Concept YC-14, Dual Mode Damping	30
15	ALG Concept Configuration for KC-135, Proposed 3-Stage Air Curve	32
16	ALG Concept Configuration for KC-135 Airplane	33
17	ALG Concept Configuration for T-43A, Proposed 3-Stage Air Curve	34
18	ALG Concept Configuration for T-43A Airplane	35
19	Idealized Representation of Hastily Repaired Bomb Crater	39
20	Performance Comparison YC-14 vs. KC-135 Encounter with 50 ft. Repaired Crater	40

LIST OF FIGURES (Continued)

FIGURE		PAGE
21	Idealized Representation of Rectangular Dip or Bump	41
22	Idealized Representation of Rutted Runway	41
23	YC-14 Encounter with Rectangular Obstacle	43
24	KC-135 Encounter with Rectangular Obstacle	44
25	YC-14 Encounter with Rutted Runway	46
26	KC-135 Encounter with Rutted Runway	47
27	Wing Upper Surface Skin - Stringer Attachment	50
28	Landing Gear Lever Beam	50

LIST OF TABLES

TABLE		PAGE
1	Mathematical Models for ALG Development	4
2	Oleo Description	5
3	Significant Airplane Parameters and Constants	7
4	Simulated Conditions for Survivability Analysis	38
5	Wing Upper Surface Detail Damage	51
6	Landing Gear Lever Beam Damage	52
7	YC-14 Damage Reduction due to Adaptive Gear	54

SUMMARY

This report describes all work related to Contract F33615-76-C-3004
"Development of Adaptive Landing Gear for Military Aircraft Evaluation."

Taxi performance in terms of airplane CG (RMS) acceleration was evaluated with a digital simulation for the T-43A, KC-135 and the YC-14. Simple landing gear oleo modifications such as metering pin bypass orifices, and dual stage air chambers were then used to reduce airplane CG acceleration by as much as 47%. The study indicated that oleos with a single stage air curve would benefit from a two stage design. For an oleo with an initial two stage air curve, reduced hydraulic damping forces resulting from a metering pin bypass orifice showed improved taxi performance. Additional improvement was achieved by softening the second stage spring rate and adjusting it to the anticipated airplane touchdown weight.

Payoff in terms of taxi imposed gear loads and fatigue damage was evaluated. Results indicated that the KC-135 and YC-14 type gear benefit from the modifications when obstacles of medium wave length are encountered because the induced vertical and horizontal loads are lower than those calculated with the baseline gear. In the case of short wavelength bumps (dips and bumps) only the damping modification for the YC-14 gear results in reduced vertical and horizontal loads. A similar analysis for the KC-135 indicates no significant changes in loads. Fatigue analysis for the YC-14 shows a measureable increase in life as long as missions are conducted from austere fields. If missions from prepared runways are included, then the payoff in terms of reduced fatigue damage is very small.

PRECEDING PAGE BLANK-NOT FILMED

1.0 INTRODUCTION

Traditionally, landing gear shock strut design has been based entirely on touchdown requirements. The oleo stroke length is a function of maximum touchdown load, impact velocity, stroking efficiency, and tire deflection. The metering pin is shaped to provide the required stroking efficiency for the design case. In general, it has been found that the shock strut designed for landing is acceptable for taxiing on prepared runways.

Recent experience with airplanes operating on semi-prepared fields has shown that dynamic taxi loads can cause considerable fatigue damage, comparable to the effect of turbulence during flight.

For example, on some of the C-130 airplanes operating repeatedly on semi-prepared fields in South East Asia, fatigue damage did occur and did result in costly repairs and modifications.

Air Force airplanes must, however, operate from austere airfields and as a result experience severe penalties due to taxi induced loads and reduced ground performance.

Also, survivability is of major concern for AF airplanes where the ability of the airplane to operate on combat-damaged surfaces may be required for the successful completion of its mission. Advanced gear technology also holds promise for improved sortie rate when used on advanced tactical fighters. Therefore, studies were initiated to develop simple passive adaptive landing gear concepts which will increase the fatigue life and survivability, and improve the ground handling of existing and future Air Force airplanes. Particular emphasis was placed on the modification of oleo parameters such as air-spring rate, metering pin and rebound orifice damping, so that the adaptive landing gear could only have a minor impact on system complexity and life cycle costs.

This work has been carried out in the following phases.

- a) Analytical determination of the shock strut characteristics required to improve ground roll and taxi performance. (KC-135, T-43A, YC-14).
- b) Realistic determination of simple hardware concepts required for improved taxi performance. (KC-135, T-43A, YC-14).
- c) Payoff in terms of gear loads when taxiing over discrete obstacles such as repaired bomb craters, bumps and dips, and rutted runway. (KC-135, YC-14).
- d) Payoff in terms of fatigue life when operating from prepared and semi-prepared fields. (YC-14).

The study was conducted for three different airplanes, in order to derive some generally valid conclusions.

2.0 METHOD OF ANALYSIS

The analysis for the adaptive landing gear was performed for the T-43A, KC-135 and the YC-14. Each of these airplanes have main landing gears of different design. The T-43A (Boeing 737) has a very conventional T - type gear which is designed for prepared runways and normal sink rates. The KC-135 has a truck type gear and is also designed for prepared runways and normal sink rates. The YC-14 has a trailing arm gear and four main gear posts even though the operational gross weights are less than those of a Boeing 727. The YC-14 gear is designed for STOL landings, high flotation and taxi over austere runways.

2.1 Airplane Models

The analysis was performed with a digital program coded in MIMIC language which included an accurate non-linear dynamic representation of the landing gear, air frame, and aerodynamic forces. Principal airplane motion about the center of gravity is calculated in the pitch axis only. The model does not include calculation of motion about the roll axis. The dynamic response of left and right main gears is therefore identical.

Table 1 summarizes the contents of each simulation, namely the airplane degrees of freedom, the flexible modes, the simulation of the main and nose gear forces and the representation of the aerodynamic and thrust forces. More details of the oleo simulation are shown on Table 2. For most cases the tire was represented as a linear spring. No damping forces were assumed. For short wave length runway disturbances where profile transitions are of significant height and occur in less than three tire foot print lengths a pneumatic tire model was used to represent the tire as a toroidal membrane and calculates horizontal and vertical ground contact forces.

TABLE 1 - MATHEMATICAL MODELS FOR ALG DEVELOPMENT

AIRPLANE	AIRPLANE DEGREES OF FREEDOM		MAIN GEARS		NOSE GEAR		AERODYNAMIC AND THRUST FORCES
	RIGID	FLEXIBLE	TYPE	FORCES SIMULATED	TYPE	FORCES SIMULATED	
YC-14	Vertical	6 Most	Levered	Pneumatic (3 Stage Air-curve)	Levered	Pneumatic	Separate Simulations used for Take-Off and Landing Effects included are: 1. C_l , $C_{l\alpha}$, C_m , $C_{m\alpha}$ 2. Engine Thrust Effects during Take-Off 3. Engine Reverse Thrust Effects during Landing
	Pitching	Significant Modes	(Front and Aft Gear Simulated Separately)	Metering Pin Damping Rebound Damping	Metering Pin Damping Rebound Damping	Metering Pin Damping Rebound Damping	
KC-135	Vertical	6 Most	Truck	Pneumatic	Two Wheel	Pneumatic	Take-Off Configuration only. Effects included are: C_l , $C_{l\alpha}$, C_m , $C_{m\alpha}$
	Pitching	Significant Modes	(Pitching D.O.F. included)	Metering Pin Damping Rebound Damping Friction	Metering Pin Damping Rebound Damping Friction	Metering Pin Damping Rebound Damping Friction	
T43-A	Vertical	6 Most	Two Wheel	Pneumatic	Two Wheel	Pneumatic	Take-Off Configurations only. Effects included are: C_l , $C_{l\alpha}$, C_m , $C_{m\alpha}$
	Pitching	Significant Modes		Metering Pin Damping Rebound Damping Friction	Metering Pin Damping (Uni-directional) Rebound Damping Friction	Metering Pin Damping (Uni-directional) Rebound Damping Friction	

TABLE 2: OLEO DESCRIPTION
 THE ANALYTICAL REPRESENTATION OF ALL MAIN AND NOSE GEAR OLEOS INCLUDES:

FORCE COMPONENT	ANALYTICAL REPRESENTATION	NOTES
PNEUMATIC	ISOTHERMAL COMPRESSION, SINGLE OR 3 STAGE	YC-14 MAIN GEAR IS 3 STAGE
HYDRAULIC DAMPING	v^2 - DAMPING, STROKE DEPENDENT	METERING PIN SIMULATED
REBOUND DAMPING	v^2 - DAMPING, DIRECTION DEPENDENT	BACKLASH OF REBOUND RING INCLUDED
FRICTION	UPPER AND LOWER BEARING FRICTION	NEGLECTED ON YC-14
"EXTENDED" STOP	STIFF SPRING	
"COMPRESSED" STOP	MONITORED ONLY TO INDICATE IF EXCEEDED	

The most significant airplane parameters and constants used in the taxi simulations are summarized on Table 3.

2.2 The Runway Model

Excitation to the taxi model was for most cases perturbation of the ground with a profile closely approximating the runway power spectral density per MIL-A-008862A. An artificial runway profile was generated with a normally distributed random number generator and a digital filter as shown on Figure 1. The calculated power spectral density of the runway model was found to be in good agreement with the required values. The profile allows the representation of prepared, semi-prepared and unprepared runway by a simple adjustment of the output signal magnitude. The artificial runway profile assures an even distribution of all excitation frequencies and precludes a unique characteristic of an actual runway profile from impacting the design of the adaptive landing gear.

2.3 Carpet Plots

The approach for this study was to custom tailor the oleo characteristics for improved taxi performance such as a decrease in airplane C.G. acceleration in response to taxi excitation and reduction in peak landing gear loads when certain discrete obstacles are encountered. Taxi loads are transferred into the airframe through the landing gear oleo by way of two possible load paths. One such path is completed with the pneumatic spring. Forces generated by the spring are directly related to the relative displacement between inner and outer cylinder. The second load path is generated with the hydraulic damping forces of metering pin and rebound damper. These damping forces are directly proportional to the squared velocity difference between inner and outer oleo cylinder. As the pneumatic air curve and damping orifices are varied parametrically, changes to the C.G. acceleration result. The sample plots

Parameter or Constant	Units	Airplane Model		
		YC-14	KC-135	T-43A
<u>1. Airplane</u>				
Airplane gross weight	lbs	150 000	297 000	98 000
Airplane polar moment of inertia pitching D.O.F.	lbs in ²	1.64x10 ¹⁰	2.14x10 ¹⁰	4.45x10 ⁹
Body station of airplane C.G.	in	641.2	837.9	681.2
Body station of nose gear attachment point	in	186.5	339.0	289.2
Body station of main gear attachment point	in	640.5 Front 700.5 Aft	887.0	728.7
Mean aerodynamic chord	in	176.4	242.	134.
Effective wing area	ft ²	1762.	2433.	980.
<u>2. Main Landing Gear</u>				
Unsprung weight	lbs	960.	2842.	952.
Strut stroke, stop to stop	in	16.56	22.0	14.0
Pneumatic area	in ²	41.15	78.54	28.27
Air pressure, strut fully extended	psig	315.	220.	250.
Hydraulic area	in ²	32.33	68.67	28.27
Orifice coefficient, metering pin	-	.88	.88	.88
Diameter of metering orifice	in	2.02	2.0	1.075
Metering pin diameter vs. stroke	in ²	See Table 2		
Hydraulic area, rebound chamber	in ²	12.30	12.05	7.55
Rebound orifice area, strut compressing	in ²	1.0	.496	.510
Rebound orifice area, strut extending	in ²	.05	.496	.018
Rebound ring travel, stop to stop	in	.38	-	.20
<u>3. Nose Landing Gear</u>				
Unsprung weight	lbs	702.	381.	185.
Strut stroke, stop to stop	in	12.80	16.0	12.0
Pneumatic area	in ²	19.63	19.63	8.30
Air pressure, strut fully extended	psig	440.	165.	237.
Diameter of metering orifice	in	1.400	1.250	.752
Metering pin diameter vs. stroke	in ²	See Table 2		
Hydraulic area	in ²	11.83	15.41	

TABLE 3 SIGNIFICANT AIRPLANE PARAMETERS AND CONSTANTS

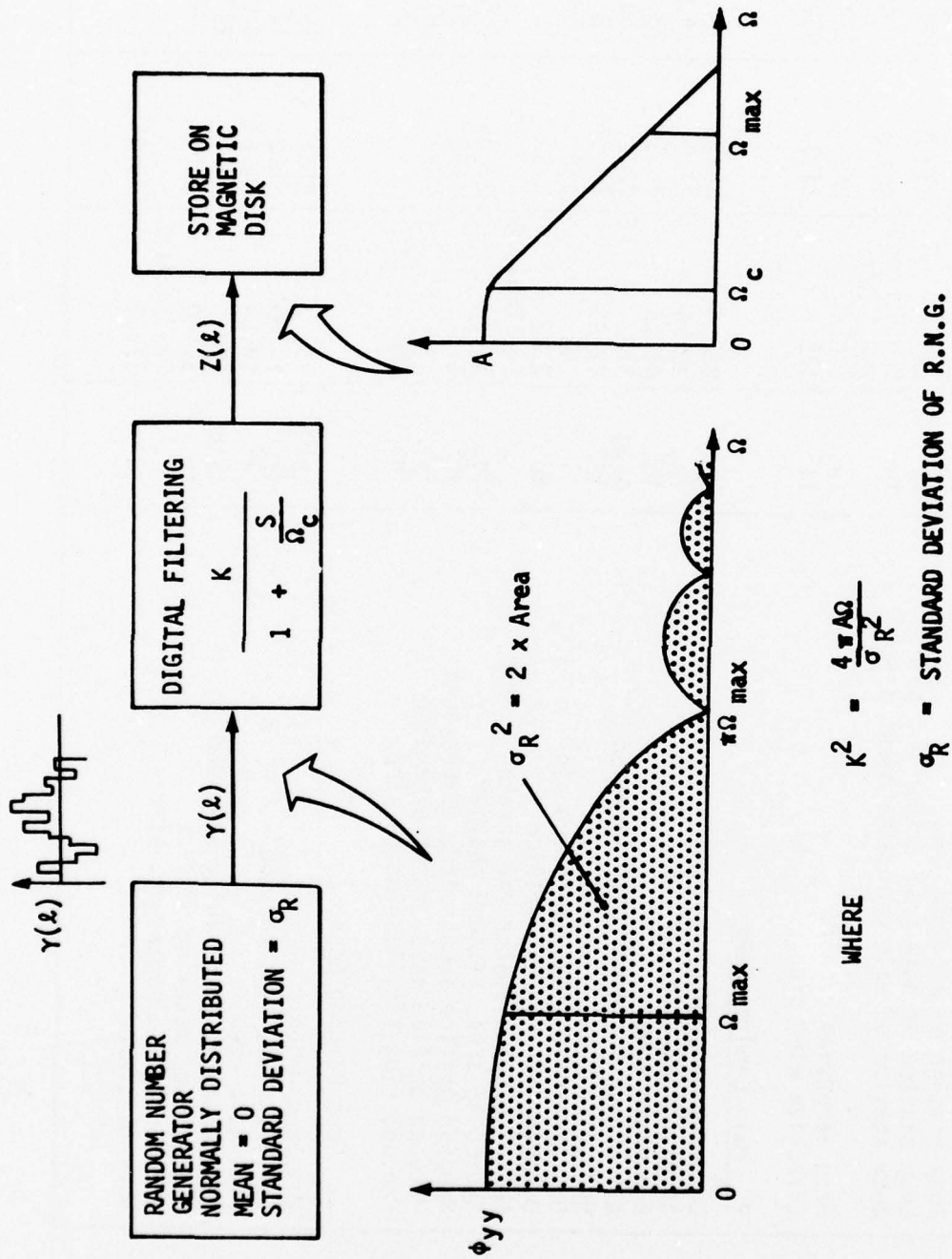

FIGURE 1 NUMERICAL METHOD USED TO GENERATE RANDOM RUNWAY

shown on Figure 2 show the effect of changing the air spring and damping coefficient in equal increments. Depending on baseline conditions the effect on C.G. acceleration can differ. If, as an example, the initial air spring is very soft and damping forces are the cause of most airframe excitement, of course only a reduction in these damping forces will result in a reduction in airplane acceleration. Conversely, if the air spring is very stiff and damping forces are minor, only a reduction in air spring stiffness will decrease the airplane acceleration.

2.4 Operating Conditions

The operating conditions used for the parameter variation studies are as follows: For the YC-14, the selected conditions represent the anticipated operating conditions at the mid-range point. The assumed airplane gross weight was in all cases 150,000 lbs. For landing and take-off operations, semi-prepared field conditions were assumed, and for the 15 KTS Taxi operation unprepared field conditions were assumed to exist. The aerodynamic and thrust forces were simulated in accordance with STOL requirements, i.e., maximum thrust during take-off and maximum reverse thrust during landing. It is worth noting that during a landing with maximum reverse thrust, an additional downward force of 50,000 lbs. acts on the airplane during most of the landing roll, resulting in a total load on all wheels of approximately 200,000 lbs.

Operating conditions 1, 2 and 3 differ from each other only in the section of runway used, starting at 1000, 2000, and 3000 feet respectively. The reason for running all three conditions was to determine the effect on the results introduced by choosing different sections of runway.

For the KC-135 airplane, the selected baseline conditions are intended to represent ground operations during a typical re-fueling mission, i.e., take-off at maximum gross weight (297,000 lbs) on a paved field.

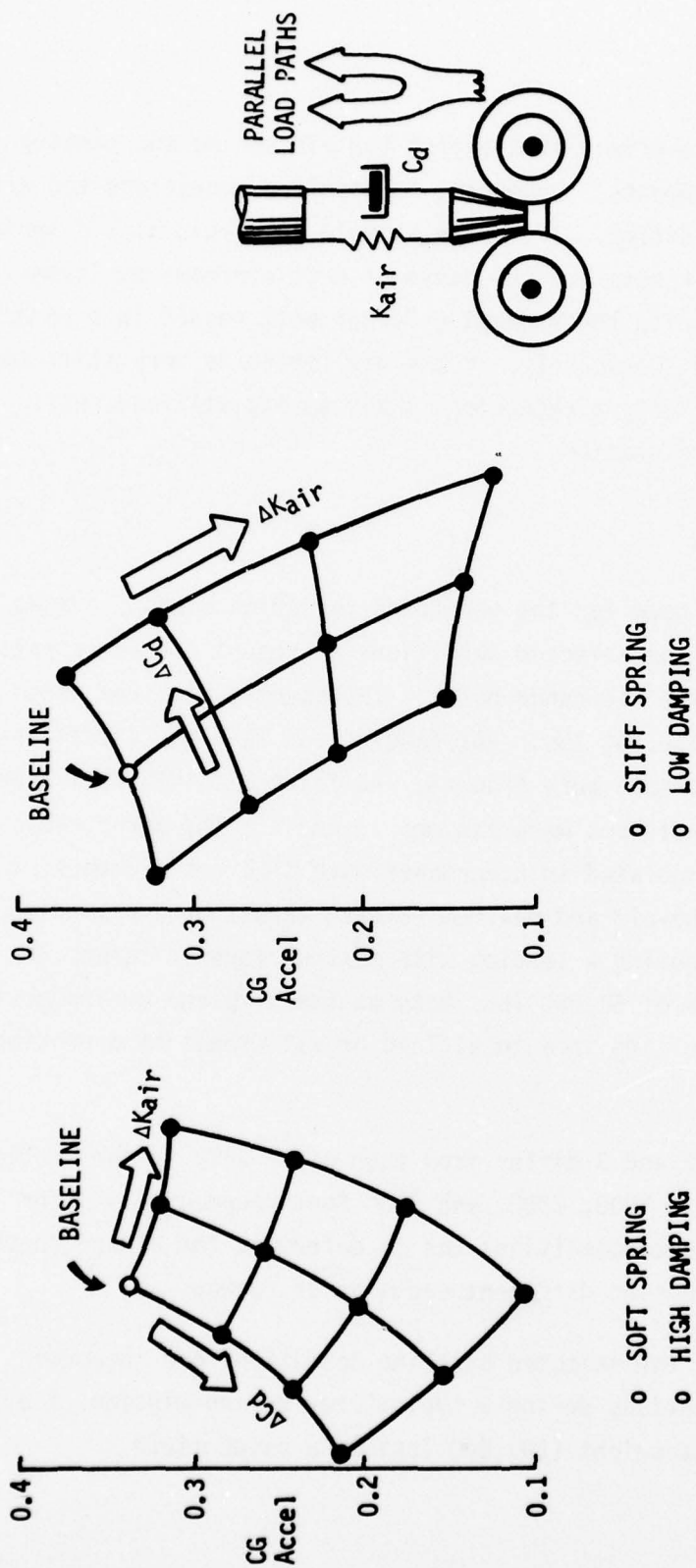

FIGURE 2 SHOCK STRUT LOAD PATHS

For the T-43A, the selected mission was a take-off on a paved field at a heavy gross weight (98,000 lbs).

3.0 RESULTS OF ANALYSIS

3.1 Data Presentation

Carpet plots are used to show the effects of air spring and damping variations on the following performance indicators:

APS	= Airplane Pilot Station Acceleration	(g RMS)
ACG	= Airplane C.G. Acceleration (major indicator)	(g RMS)
ILFN	= Incremental load factor for nose gear	(RMS)
ILFM	= Incremental load factor for main gear	(RMS)

The C.G. acceleration is the most important performance indicator, because it is a direct measure for loads and accelerations at other locations of the airplane structure.

The incremental load factor is a measure of the dynamic variations of the shock strut load,

$$ILF = \frac{F_s - F_{so}}{F_{so}}$$

where:

F_s	= Instantaneous strut force
F_{so}	= Initial strut force (= constant)

The variations of the pneumatic spring rate (K_{air}) are expressed as a percentage of the incremental spring rate of the baseline aircurve at the initial equilibrium point.

The representation of the air spring in the computer taxi model is still non-linear, however, as indicated in Figure 3. The above method of varying the pneumatic stiffness was chosen in order to retain the same initial equilibrium positions of the shock strut for the baseline and for the modified gear configuration, and thus to minimize changes of the hydraulic damping coefficient due to changes in metering pin area.

The shock strut hydraulic damping was varied by simulating a bypass orifice between the hydraulic chamber and the primary pneumatic chamber or a modification to the area of the metering pin.

3.2 YC-14 Gear Optimization

Figures 4 through 7 show the main gear optimization in chronological order. Starting from the Baseline (Figures 4 and 5) carpet plots for the landing and taxi condition were generated. Next, the rebound damping was reduced, resulting in further performance improvements. Finally, with the rebound damping optimized, further optimization of pneumatic spring and main orifice damping was performed, resulting in the final carpet plots shown in Figure 6. This figure shows the sequence used for the YC-14 main gear taxi optimization. First the oleo damping forces were decreased until no further measurable reduction in C.G. acceleration was noticed. Then the air curve was modified to result in a decrease in stiffness and improved ride quality for the taxi condition. Some adjustments were also made to the size of the rebound orifice and an even further reduction of C.G. acceleration was obtained.

Figure 7 summarizes the results of the parameter variation study for the YC-14 main gear. Data is shown for the following landing gear configurations:

1. Baseline
2. Optimized metering pin bypass orifice
3. Bypass orifice, reduced rebound damping and softer air spring which is the fully optimized configuration.

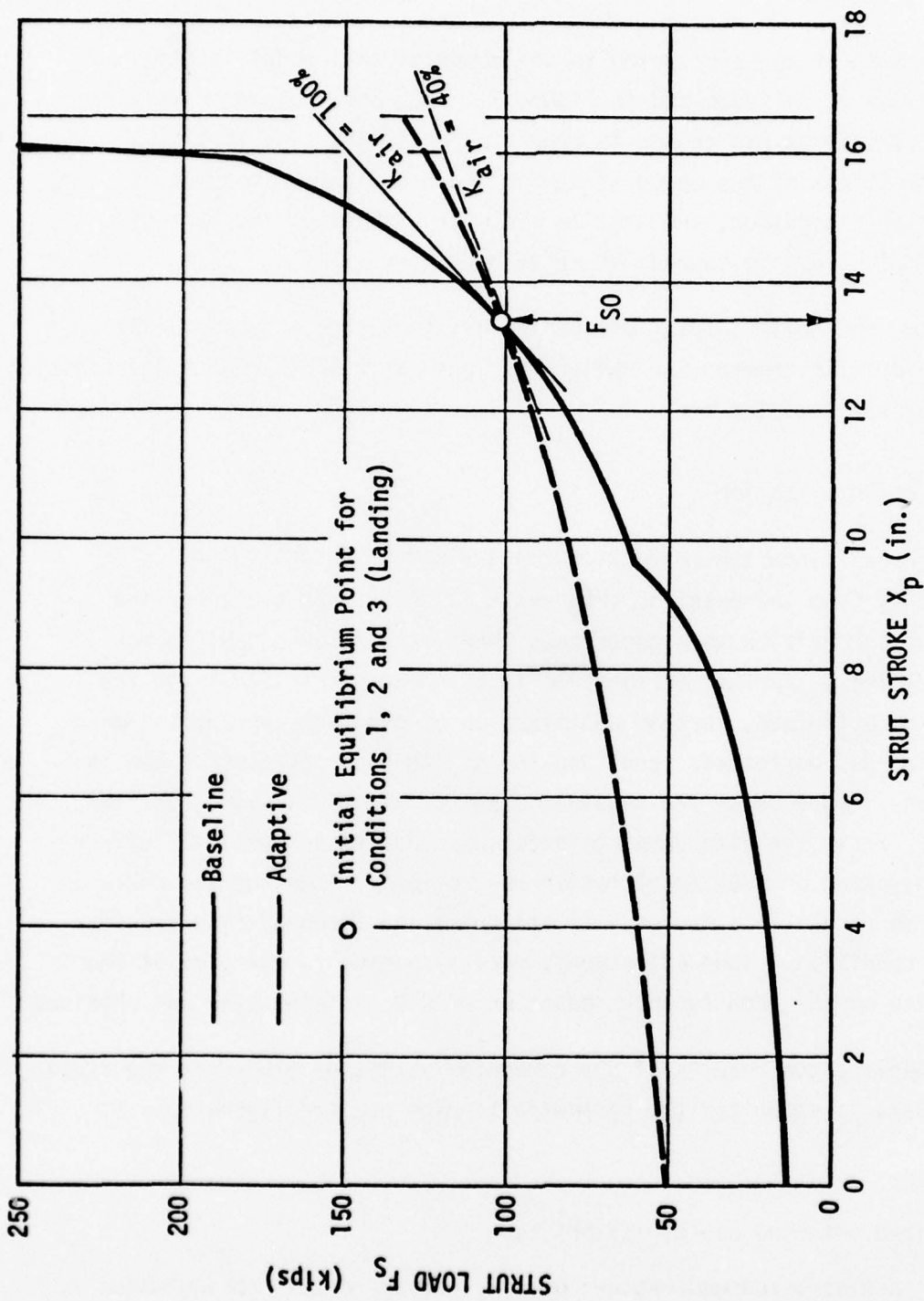

FIGURE 3 DEFINITION OF AIR CURVES

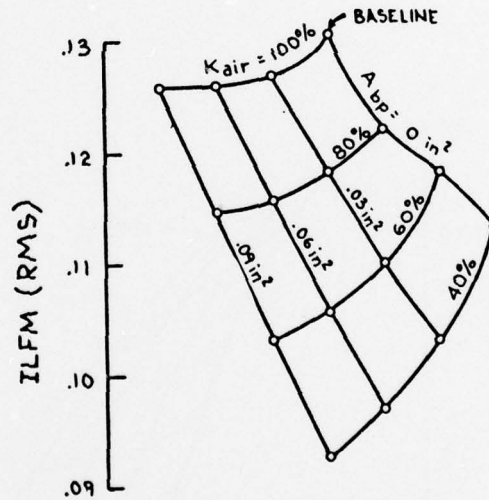
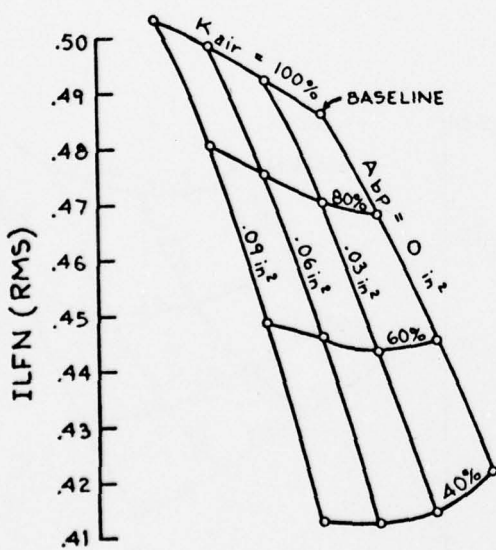
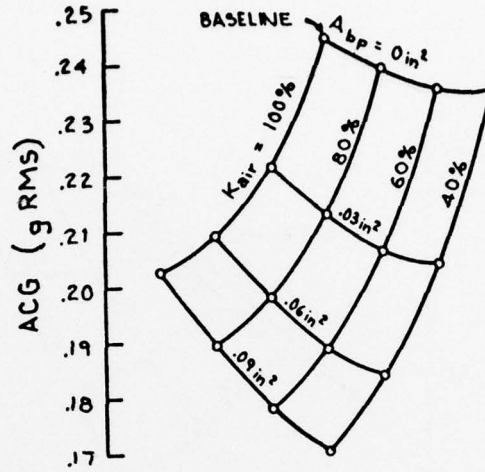
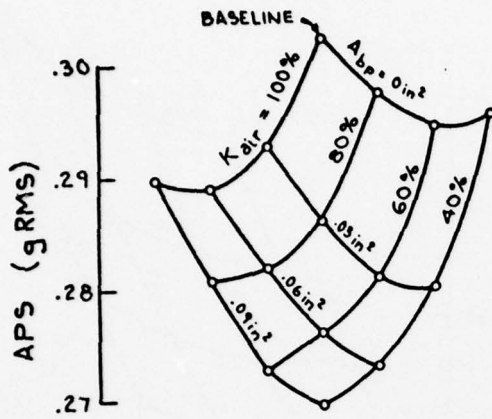

FIGURE 4 YC-14 MAIN GEAR PARAMETER VARIATION
LANDING CONFIGURATION

AIRPLANE VELOCITY 100 → 20 KTS
SEMI-PREPARED FIELD
GROSS WEIGHT = 150,000 lbs
REBOUND ORIFICE AREA = .05 in²
RUN X14R1101, X14R1102

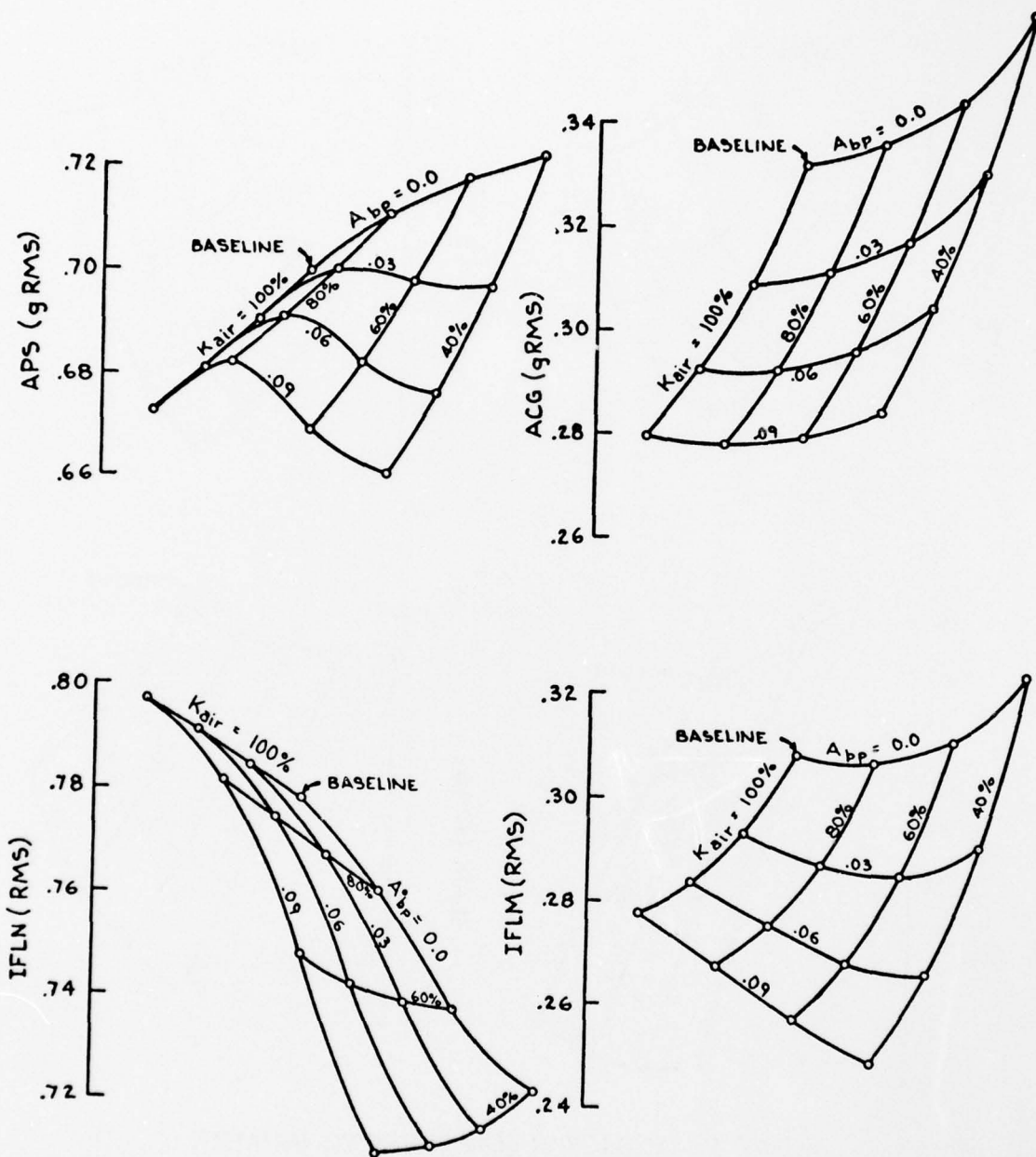

FIGURE 5 YC-14 MAIN GEAR PARAMETER VARIATION. TAXI ON UNPREPARED FIELD (25 sec at 15₂ kts), GR.WT. = 150,000 lbs (REBOUND ORIFICE AREA = .05 in²)

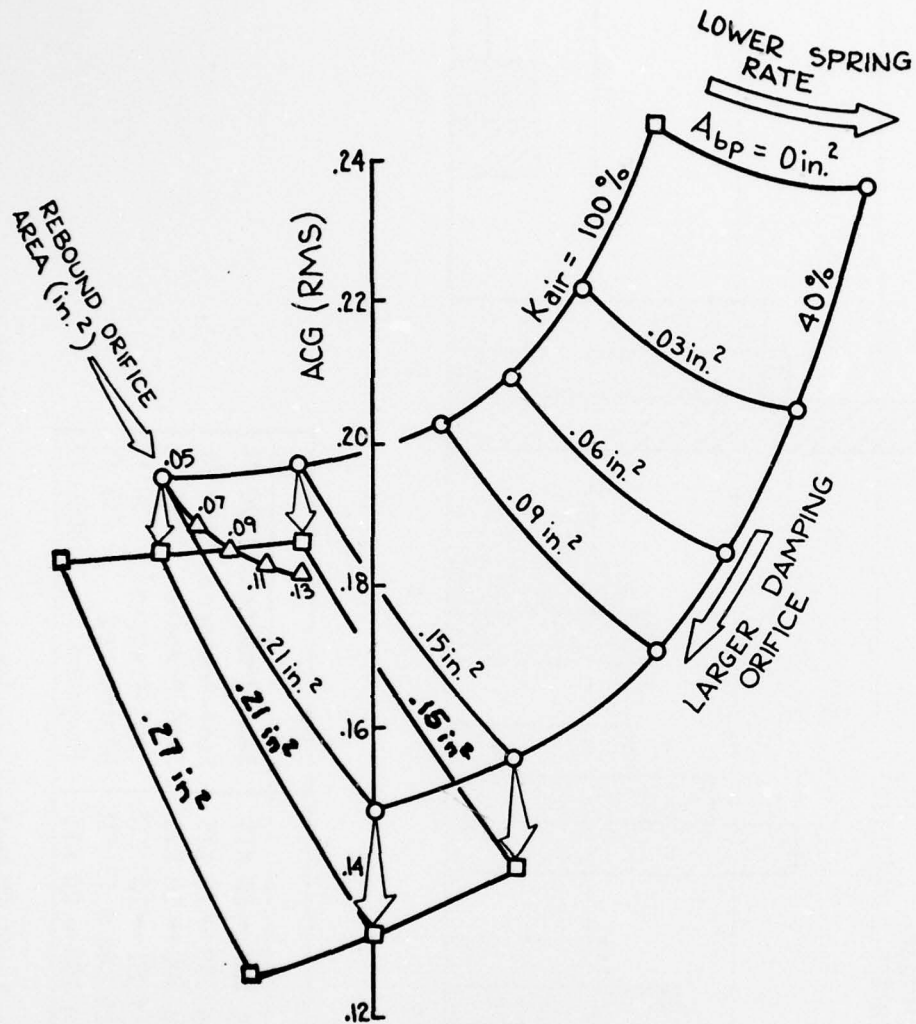

FIGURE 6 YC-14 MAIN GEAR PARAMETER VARIATION
LANDING CONFIGURATION

AIRPLANE VELOCITY 100 → 20 KTS

RUN X14R1107

SEMI-PREPARED FIELD

GROSS WEIGHT = 150,000 lbs

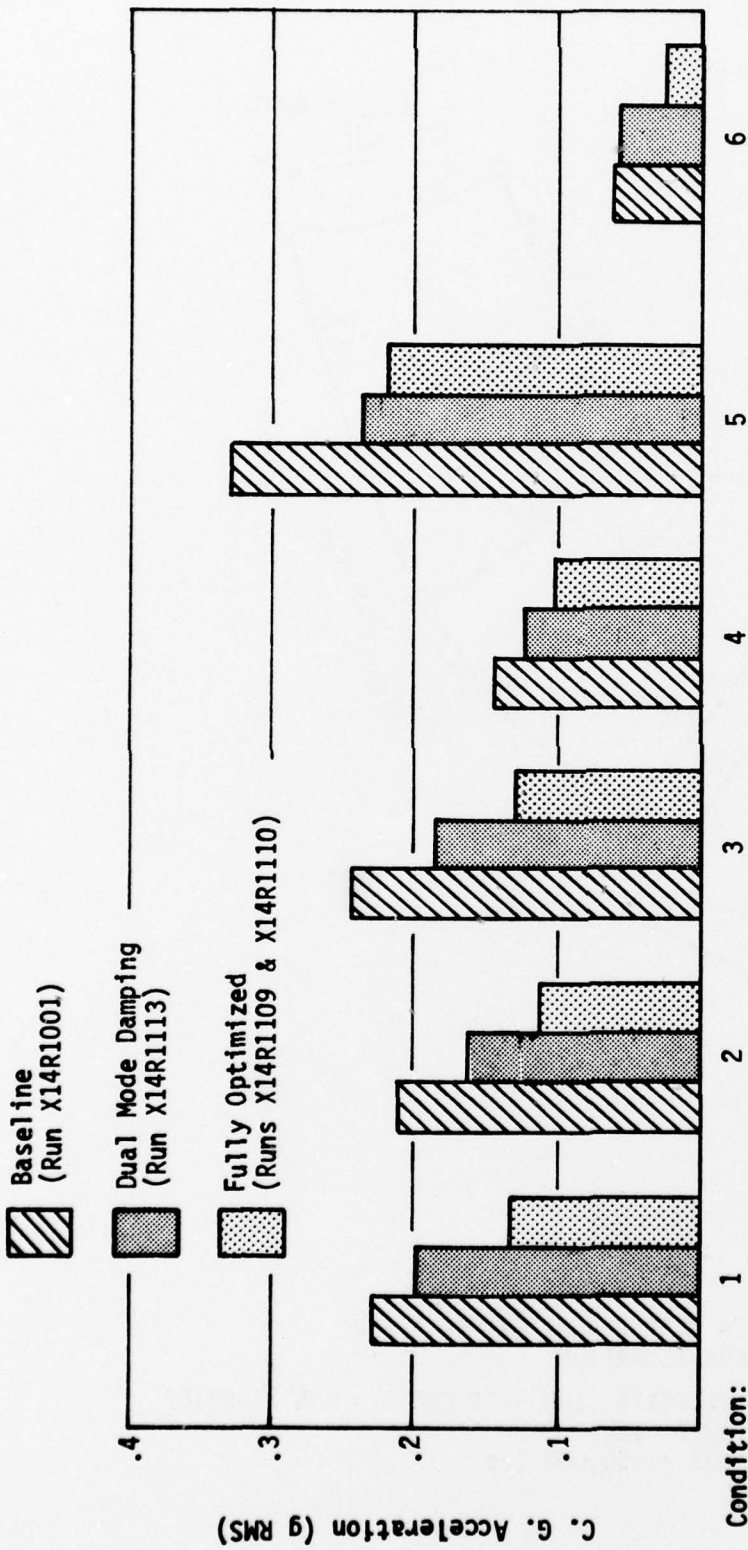

Cond.	Configuration	Run
1	Landing 100 → 20 KTS	Semi-Prepared, 1000 ft
2	Landing 100 → 20 KTS	Semi-Prepared, 2000 ft
3	Landing 100 → 20 KTS	Semi-Prepared, 3000 ft
4	Take-Off 20 → 100 KTS	Semi-Prepared, 100 ft
5	Taxi, 25 sec @ 15 KTS	Unprepared, 750 ft
6	Landing 100 → 20 KTS	Prepared, 3000 ft

Fig. 7 YC-14 Performance Summary ALG on Random Runway

It will be noted that using a Fully Optimized Configuration would reduce the C.G. acceleration substantially, typically to 60% of baseline, while use of the bypass orifice only would result in improvements of approximately half that magnitude. It is also interesting to note that the acceleration at the C.G. on a prepared runway is about 1/3 of that experienced on semi-prepared runways for all oleo configurations.

3.3 YC-14 Nose Gear Optimization

The YC-14 nose gear is a levered design with a conventional single stage oleo and metering pin. Carpet plots of the parameter variation for a reduced air spring and damping constants are shown on Figure 8. Results indicate that pilot station acceleration can be reduced by about 10% if the air spring is reduced to 40% of its original value. The effect on the airplane C.G. acceleration, however, is minor. This indicates that the pitching motion of the airplane is the chief contributor to pilot station acceleration. Because these results show no improvement to C.G. acceleration, nose gear parameter modifications have been excluded from further studies for the YC-14 type landing gear.

3.4 KC-135 Airplane

Carpet plots showing the effect of varying the air spring and the hydraulic damping are shown in Figure 9. Except for the parameter C_d defining the hydraulic damping, the meaning of symbols used in these plots is the same as on the carpet plots for the YC-14 airplane. The coefficient C_d is applied directly to the calculation of damping forces for the metering pin as shown below:

$$C_d = \frac{\text{Hydr. Damping Force of Modified Config.}}{\text{Hydr. Damping Force of Baseline Config.}}$$

Same Strut Velocity

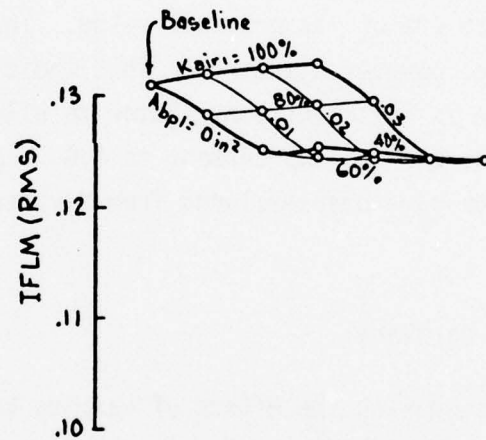
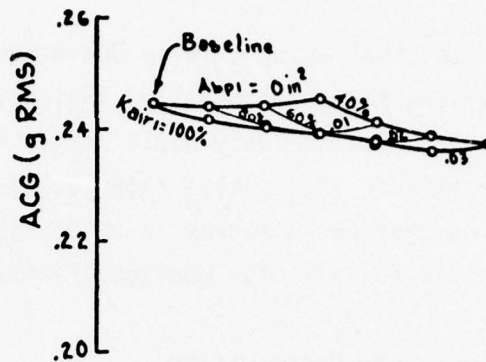
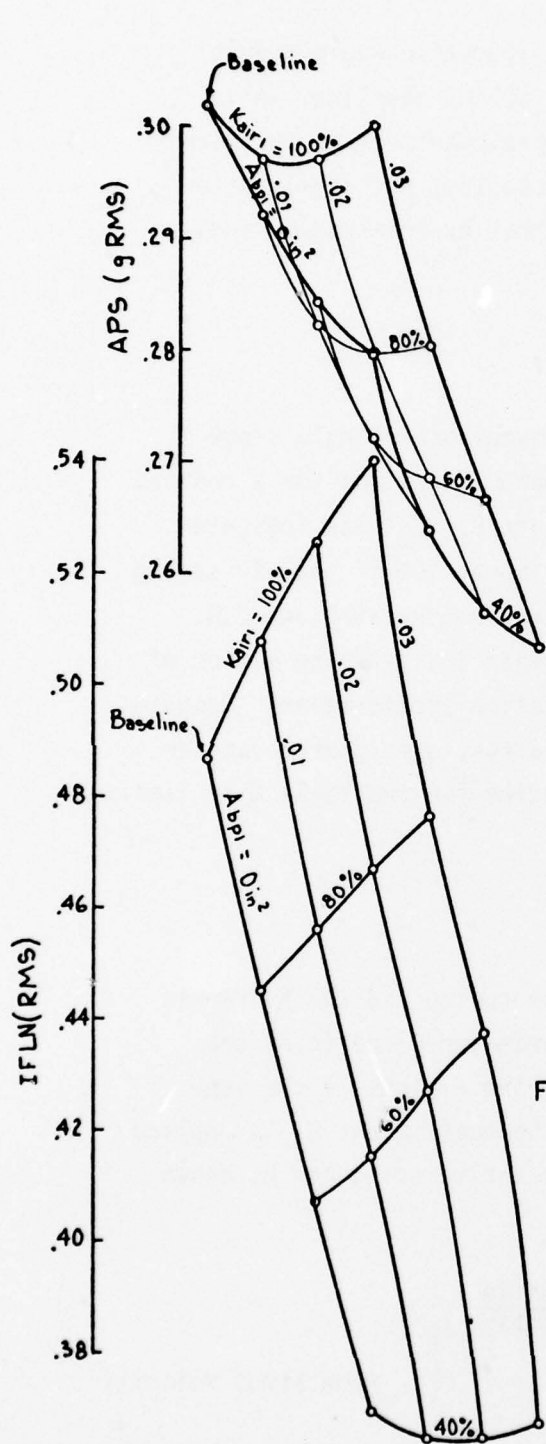

FIGURE 8 YC-14 NOSE GEAR PARAMETER VARIATION.
 LANDING CONFIGURATION
 AIRPLANE VELOCITY 100 → 20 KTS
 SEMI-PREPARED FIELD
 GROSS WEIGHT = 150,000 lbs
 RUN X14R1106

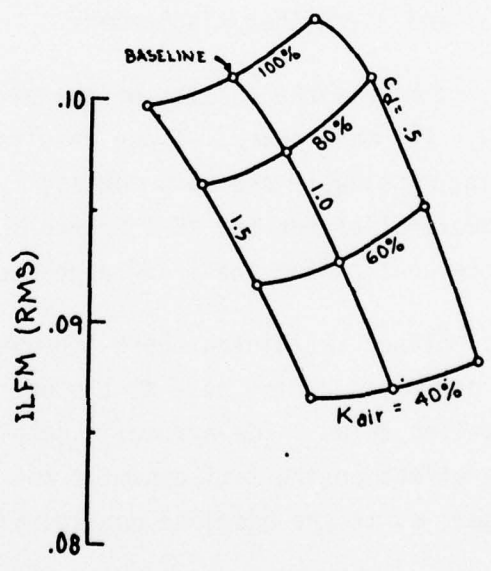
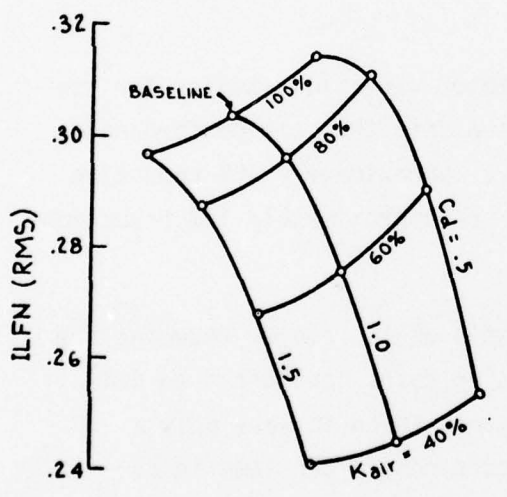
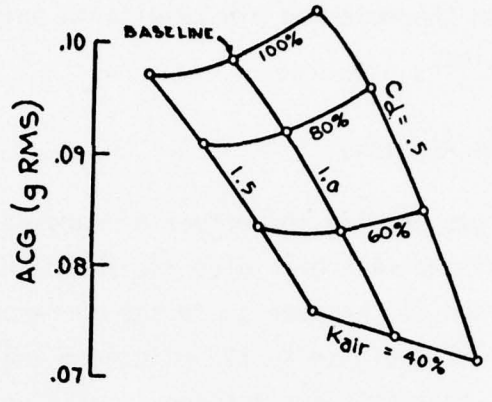
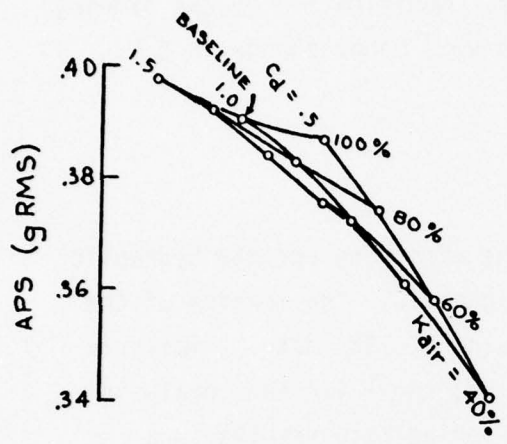

FIGURE 9 KC-135 MAIN GEAR PARAMETER VARIATION.
 MAX. WEIGHT TAKE-OFF
 AIRPLANE VELOCITY 30 → 76 KTS
 PAVED FIELD

The results indicate that a reduction in C.G. acceleration can be achieved only with a reduction of air spring stiffness. Modification of the damping force from the metering pin results in only a very minor change in C.G. acceleration.

3.5 T-43A Airplane

Carpet plots showing the effect of varying the airsprung and the hydraulic damping of the main gear oleo are shown in Figure 10. The meaning of the symbols used is the same as in the corresponding KC-135 data. Similarly to the results of the KC-135 main gear analysis, the T-43A taxi analysis indicates that only a reduction in main gear spring rate results in a reduction in airplane C.G. acceleration while the modification of metering damping forces has only a minor effect.

3.6 KC-135 and T-43A Analysis Summary

Figure 11 summarizes the results of the parameter variation studies for the KC-135 and T-43A main gears. These results indicate that the performance improvements obtainable are only modest, i.e., approximately 25% reduction in C.G. acceleration for the KC-135 airplane and approximately 11% reduction in C.G. acceleration for the T-43A airplane.

For both airplanes, attaining these improvements would require reducing the main gear pneumatic spring rate at the operating point considered to 40% of the baseline value. The hydraulic damping was found to have only a negligible effect on the taxi dynamics and would remain the same in an adaptive gear as in the baseline configuration.

The KC-135 was also analyzed when taxiing over a semi-prepared runway. This, of course, is only a hypothetical case since the KC-135 gear configuration does not allow operation on an austere field due to flotation considerations.

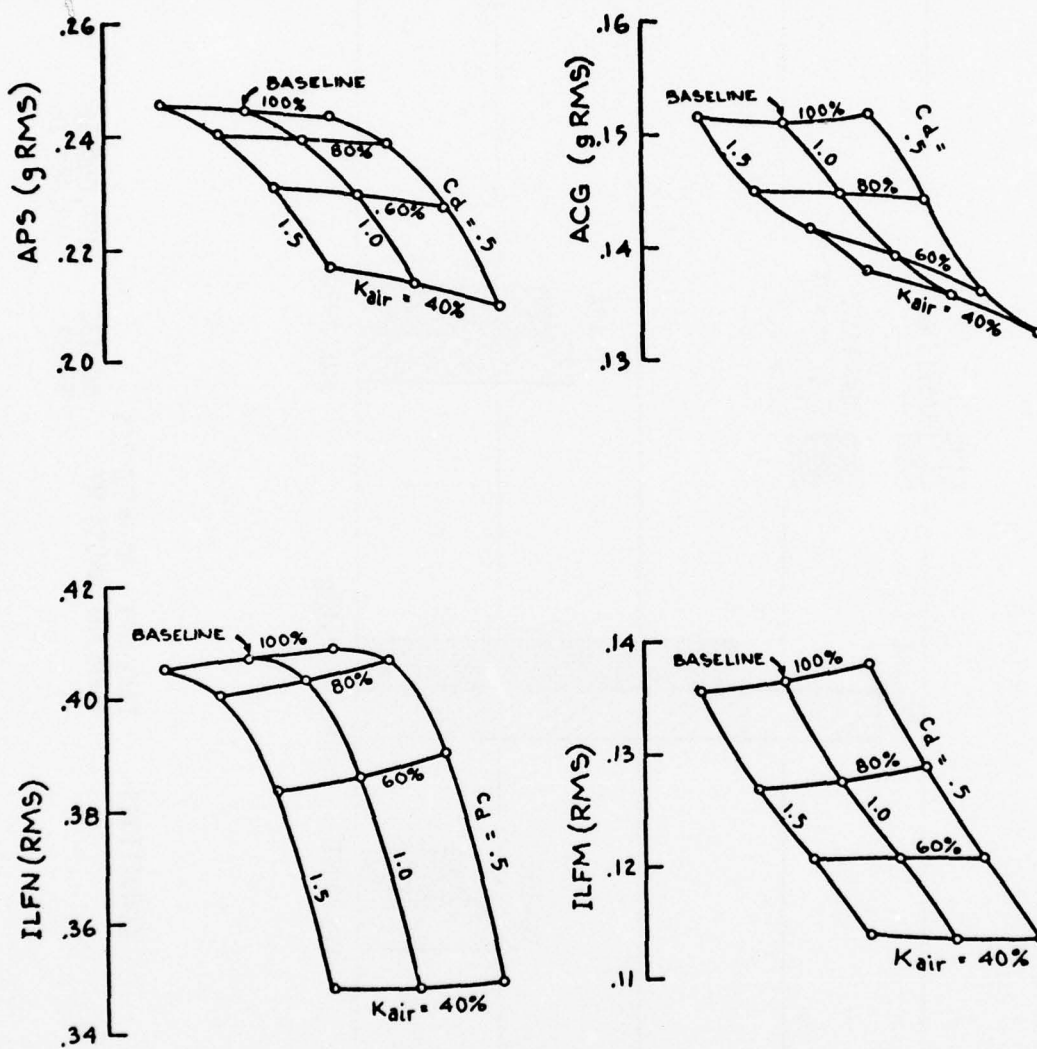
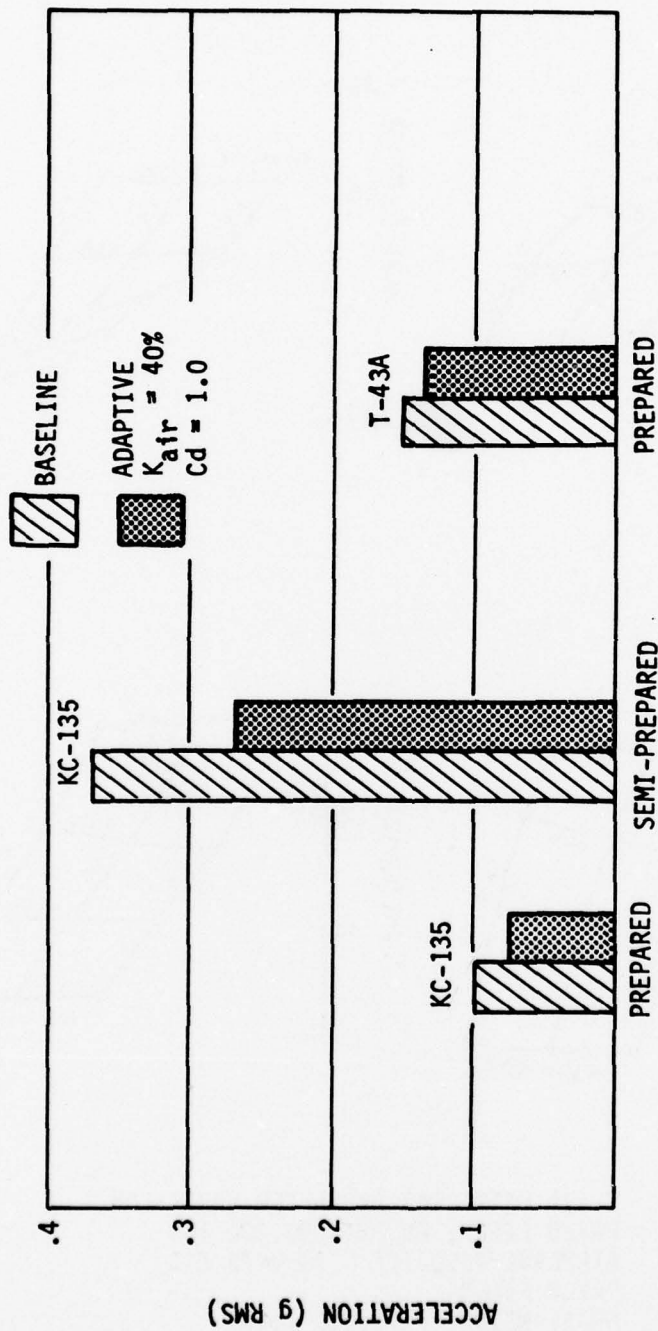

FIGURE 10 T-43A MAIN GEAR PARAMETER VARIATION.
 PAVED FIELD, GR. WT. 98,000 lbs
 AIRPLANE VELOCITY 30 → 76 KTS
 PAVED FIELD
 GROSS WEIGHT = 98,000 lbs



CONDITIONS: TAKE-OFF 30 → 76 KTS
 AIRPLANE GROSS WT. KC-135 297,000 lb
 T-43A 98,000 lb

FIGURE 11 KC-135 AND T-43A ANALYSIS SUMMARY

The summary of the results are shown on Figure 11 and indicate that the C.G. accelerations increase by a factor of 3.5 by a change in taxi environment from a prepared to semi-prepared field. The adaptive configuration reduces the C.G. accelerations induced by the semi-prepared runway. The pilot station acceleration increased from 0.39 G RMS (prepared runway) to 1.5 G RMS (semi-prepared runway) for the baseline conditions. The adaptive gear reduces the pilot station acceleration to a value of 1.25 G RMS.

4.0 HARDWARE IMPLEMENTATIONS - CONCEPTS

4.1 YC-14 Airplane

In the taxi analysis for the YC-14 type landing gear two solutions for lowering the C.G. acceleration were identified. One consisted of modified damping and a reduced air spring stiffness and the other solution required modified damping only. The effect of these modifications must come into action shortly after airplane touchdown, so that the landing dynamics is not altered. For take-off this quick switch-over is, of course, not required.

4.1.1 Fully Optimized Configuration

In the fully optimized configuration, the need for pressurizing or depressurizing the secondary air chamber in order to generate the optimum pneumatic spring rate, requires relatively complex hardware.

Figure 12 shows one possible approach for accomplishing the required pressurization/depressurization of the secondary air chamber. In this implementation, the airplane would touch down with the secondary air chamber vented to ambient. Approximately two seconds after touchdown the secondary air chamber would be pressurized and result in the soft pneumatic spring characteristics required for ground roll/taxi. Pressurization would be accomplished by connecting a pre-pressurized residual volume via a three way valve to the secondary air chamber. The residual volume V_{res} and the pressure P_{res} would be adjusted for airplane touchdown weight with the electronic control circuit. Every main gear requires a similar secondary oleo air chamber pressurization system.

Figure 13 shows the proposed method of changing the hydraulic damping in the fully optimized system. The motion of the separator piston, occurring after touchdown when the secondary air chamber is pressurized, would be used to

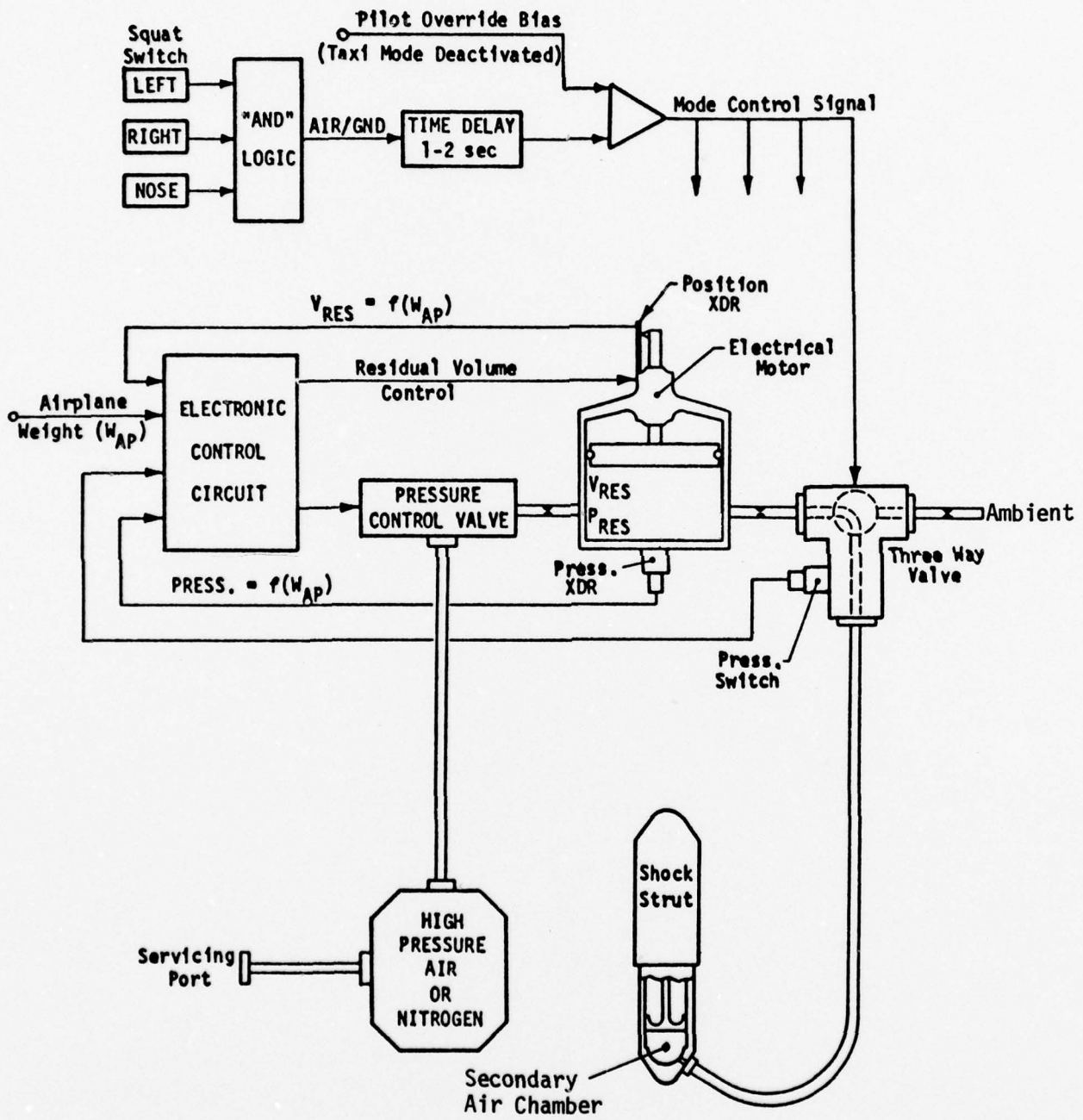
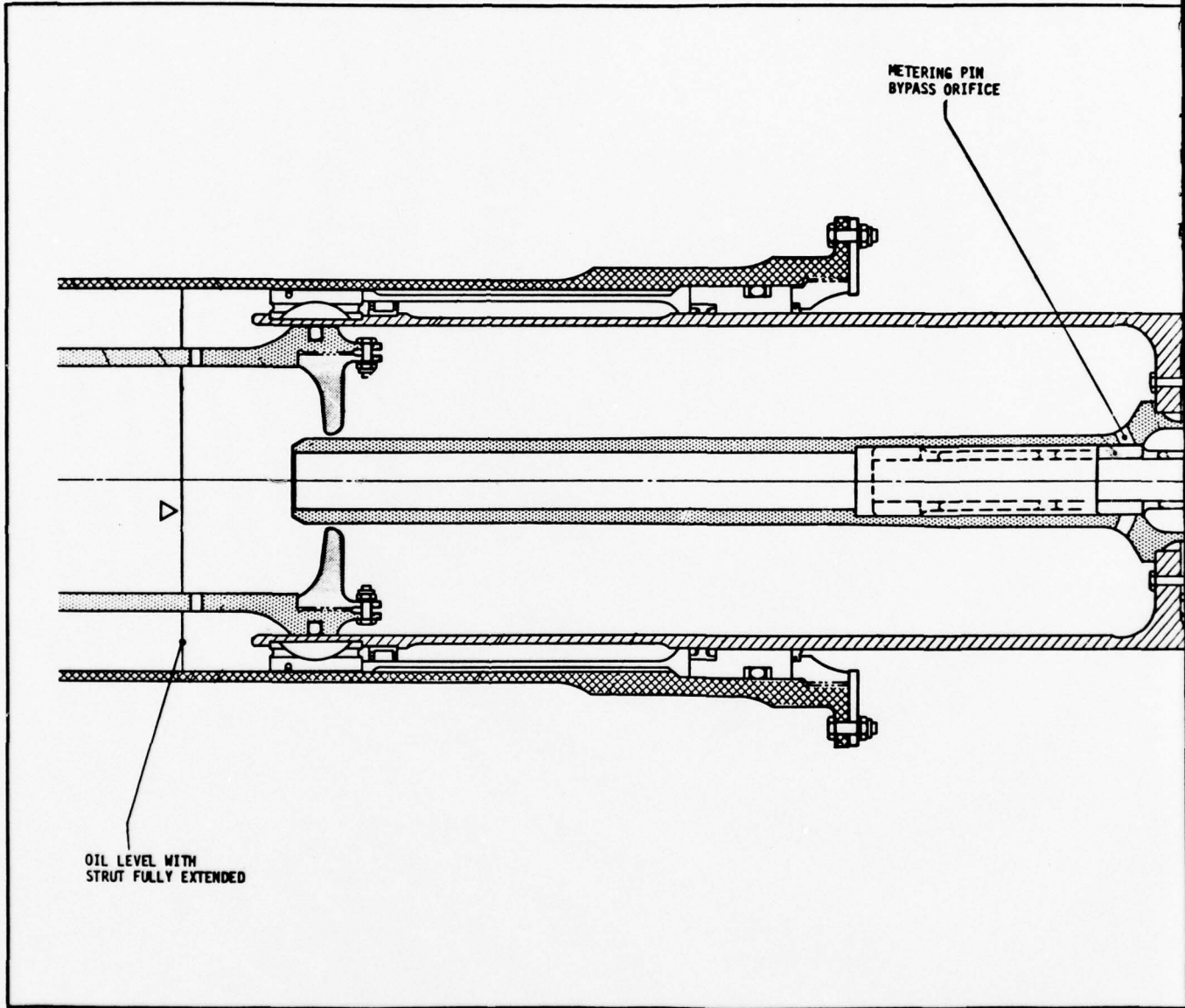
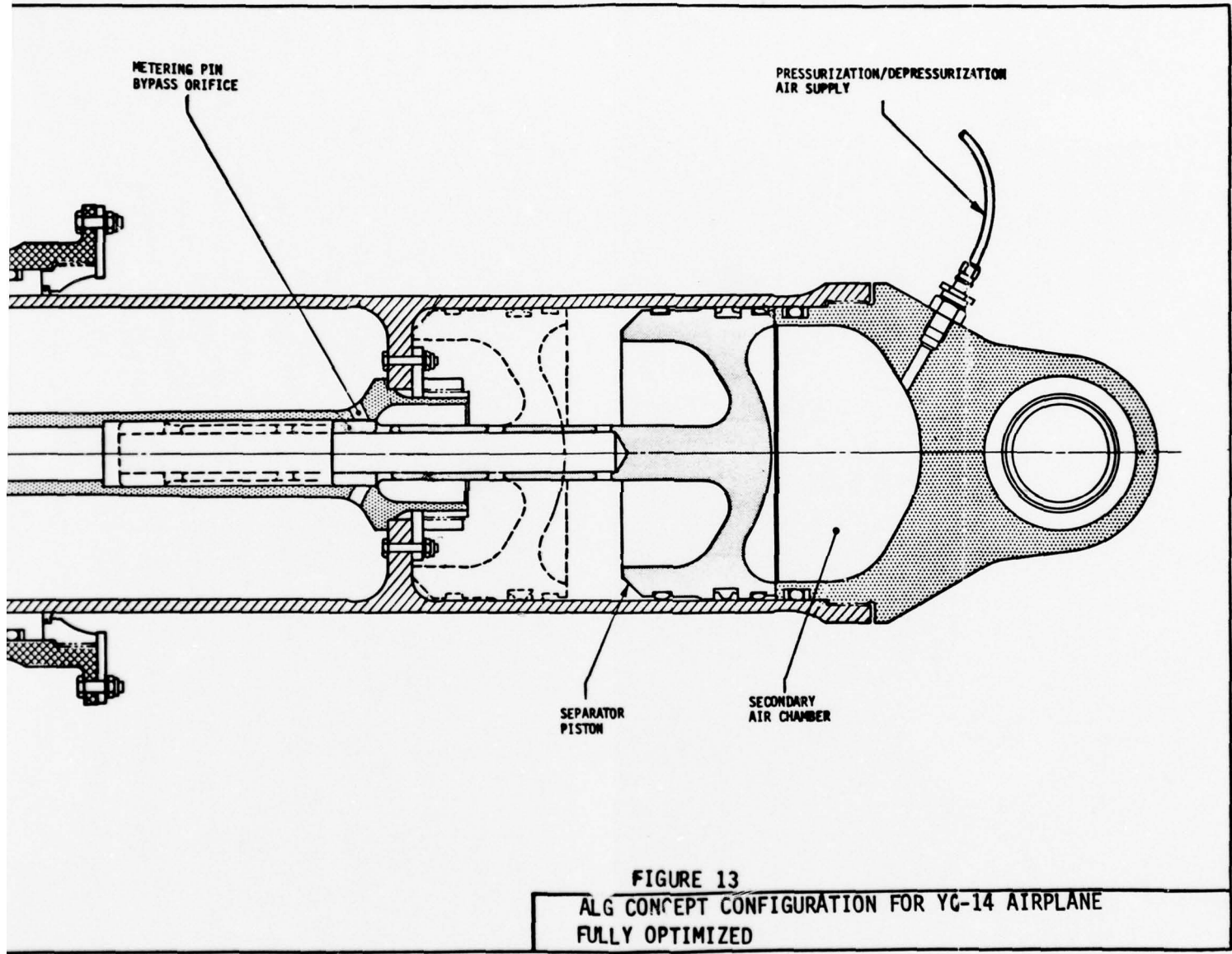

FIG. 12 TYPICAL CONTROL AND SEQUENCING LOGIC FOR FULLY OPTIMIZED ALG





2

open a metering pin bypass orifice in a simple and reliable manner.

It can be seen that the hardware modification for the fully optimized gear configuration is quite complex and requires major hardware development. In addition the weight of the airplane would undoubtedly increase. It is felt that such a complex system is not warranted for improved taxi performance.

4.1.2 Dual Mode Damping Configuration

Figure 14 shows a possible concept for implementing the Dual Mode Damping Configuration. In this system the pneumatic spring characteristics of the baseline configuration are retained. The required change of the hydraulic damping is accomplished by means of a spring loaded sliding valve.

Before touchdown, the sliding valve is kept in its uppermost position by the secondary piston. After touchdown, when the secondary piston has moved off its upper stop, the sliding valve becomes free and is moved downward by a preloaded spring, thereby opening a metering pin bypass orifice. The motion of the sliding valve is rate limited by means of a delay orifice in order to insure that the bypass orifice is not opened before the initial compression-stroke is completed. Thus, the device employed to accomplish the change of the damping coefficient is located entirely within the shock strut, requiring no external means for actuation or for sensing that touchdown has occurred. The device is extremely simple, reliable and cost effective.

4.2 KC-135 Airplane

The requirement is to soften the pneumatic spring rate to 40% of the baseline value at the operating point considered. In order to implement these softer air spring characteristics, a three stage (dual chamber) air curve,

- DESIGN SIMPLICITY
- AUTOMATIC ACTUATION
- NO PENETRATION OF OLEO
- TOUCHDOWN PERFORMANCE UNCHANGED
- DECREASED FLUID DAMPING DURING TAXI

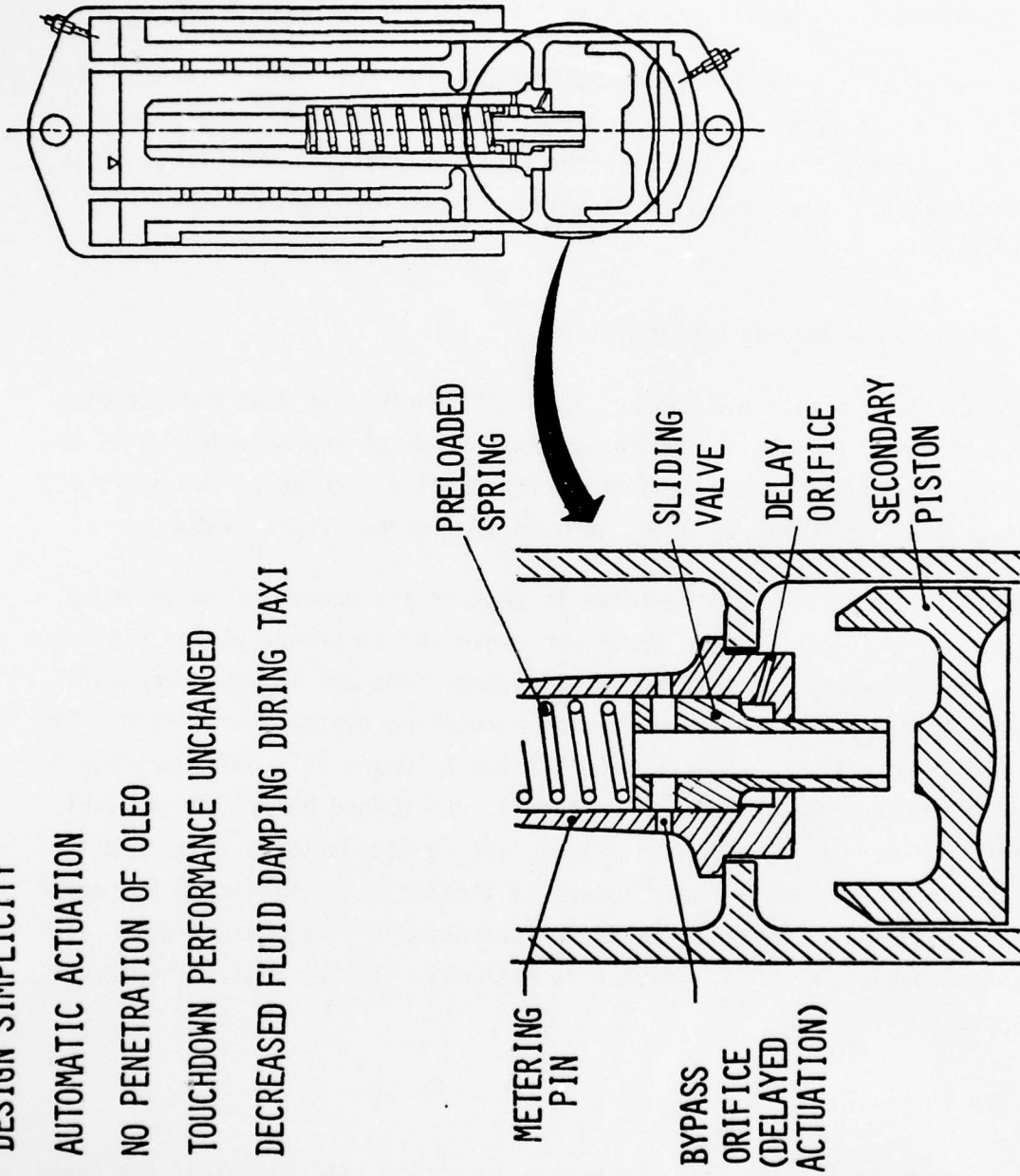

FIGURE 14 ADAPTIVE LANDING GEAR CONCEPT YC-14 DUAL MODE DAMPING

similar to the existing YC-14 design, was chosen. The required air curve, shown in Figure 15 could be implemented by a hardware modification as shown in Figure 16. In Figure 16, a presently unused volume, located within the inner cylinder below the hydraulic chamber is being used as a secondary air chamber. A separator piston is added in order to separate the secondary air from the fluid in the primary air chamber. This concept would require replacing the existing inner cylinder of the KC-135 main gear by the modified design shown in Figure 16.

4.3 T-43A Airplane

Similar to the KC-135 type landing gear the requirement is to decrease the pneumatic spring rate to 40% of the baseline value at the operating point considered. The required three-stage air curve is shown in Figure 17. This curve can be implemented by a hardware modification as shown in Figure 18.

The implementation shown in Figure 18 is similar to the concept used for the KC-135 except that the secondary air chamber can be a self contained pressure vessel within the lower part of the inner cylinder. The advantage of this type of implementation as compared to the one chosen for the KC-135 is that it would require only a modification (not a replacement) of the inner cylinder, the disadvantage would be increased weight of the landing gear.

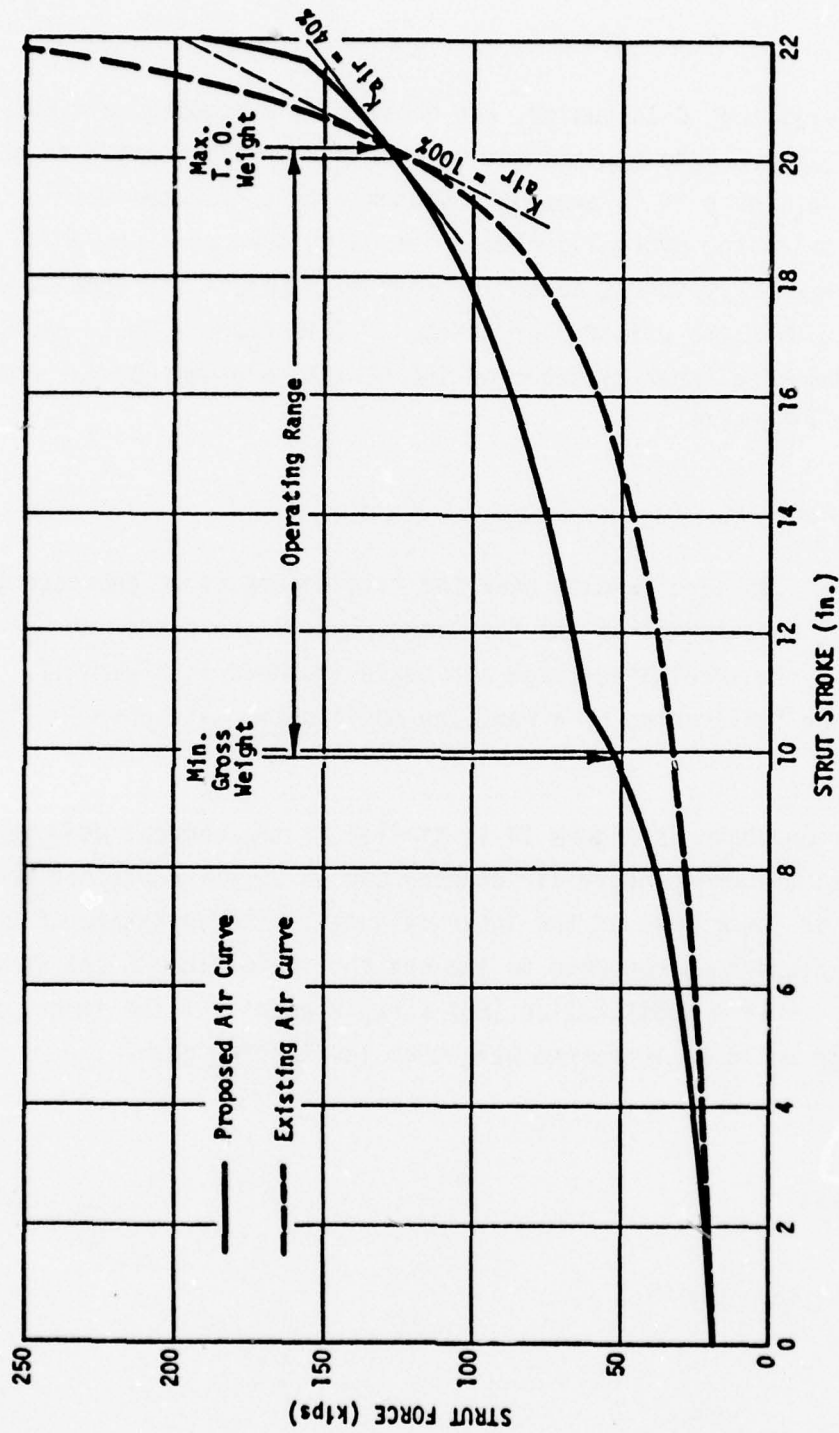
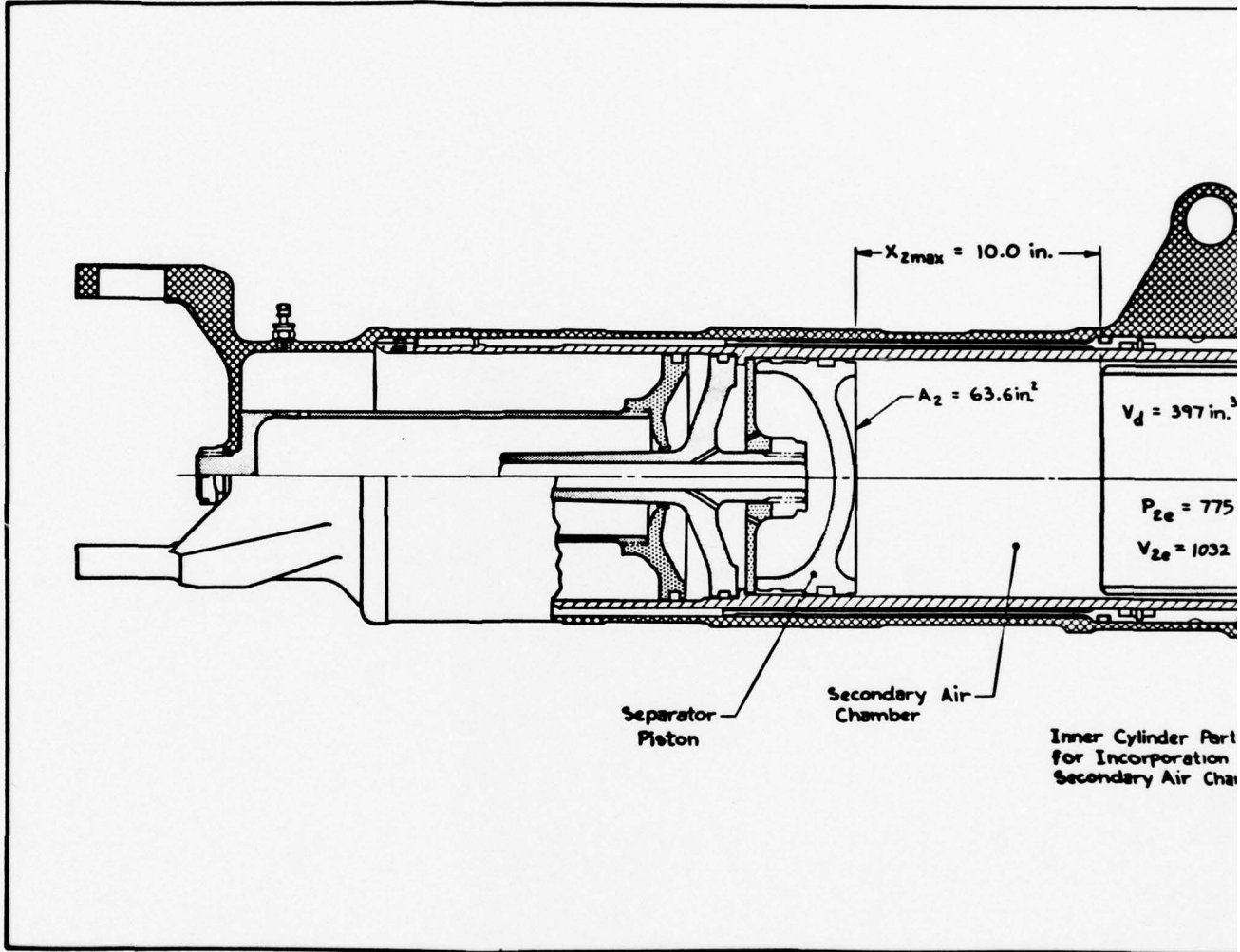

FIG. 15 ALG CONCEPT CONFIGURATION FOR KC-135 AIRPLANE. PROPOSED 3-STAGE AIR-CURVE



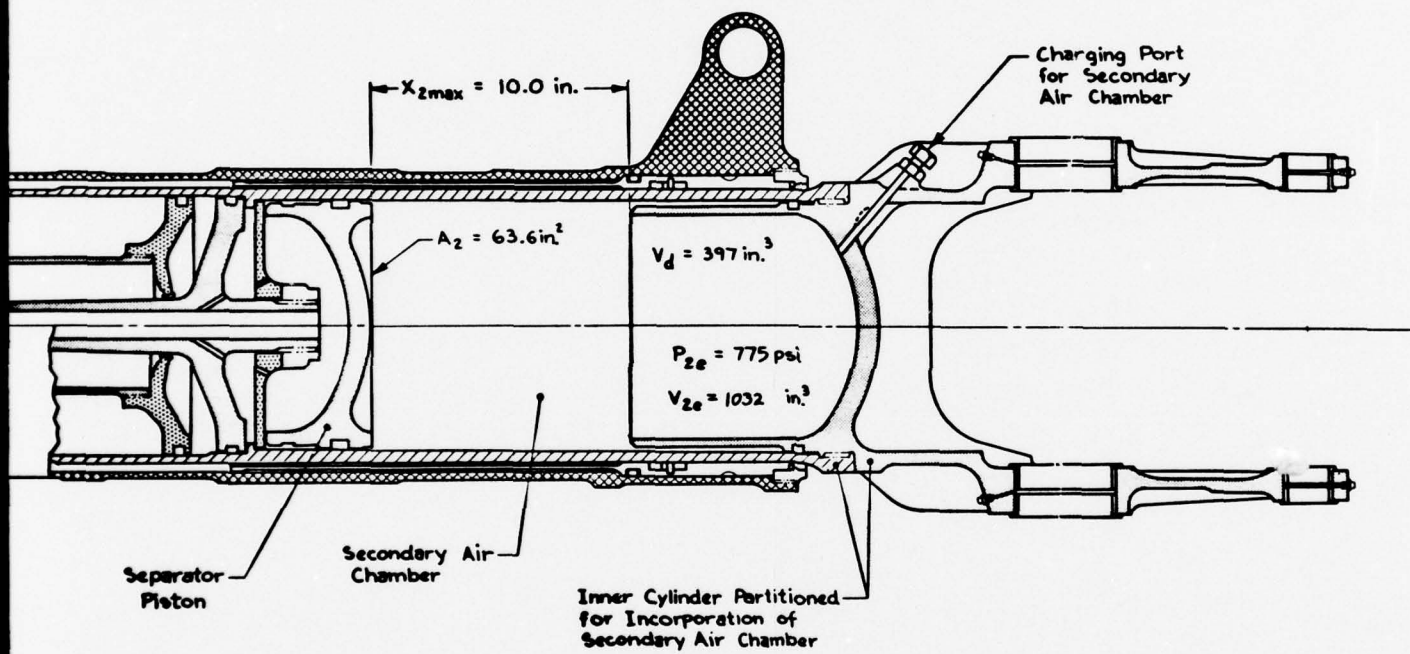

FIG. 16

ALG CONCEPT CONFIGURATION FOR KC-135 AIRPLANE MAIN GEAR SHOCK STRUT MODIFIED FOR 3-STAGE AIR CURVE

2

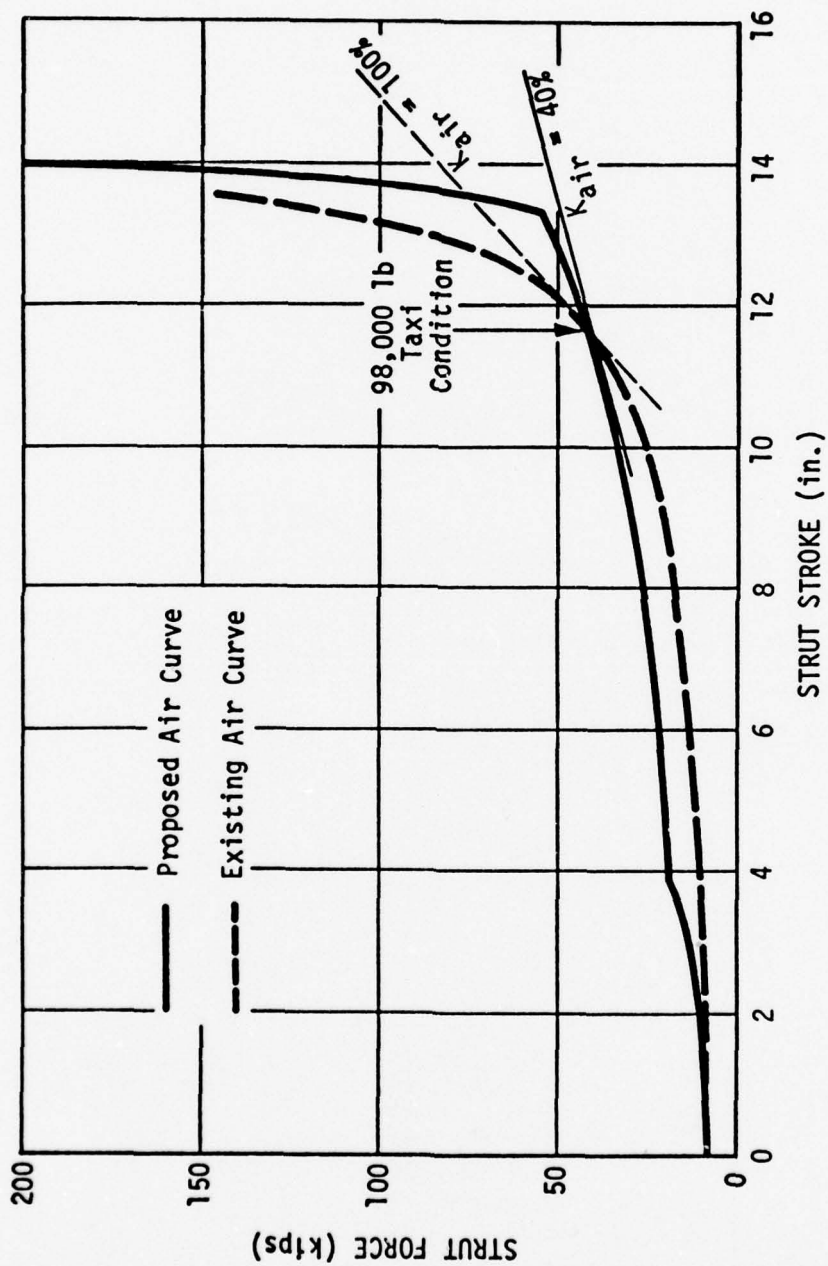
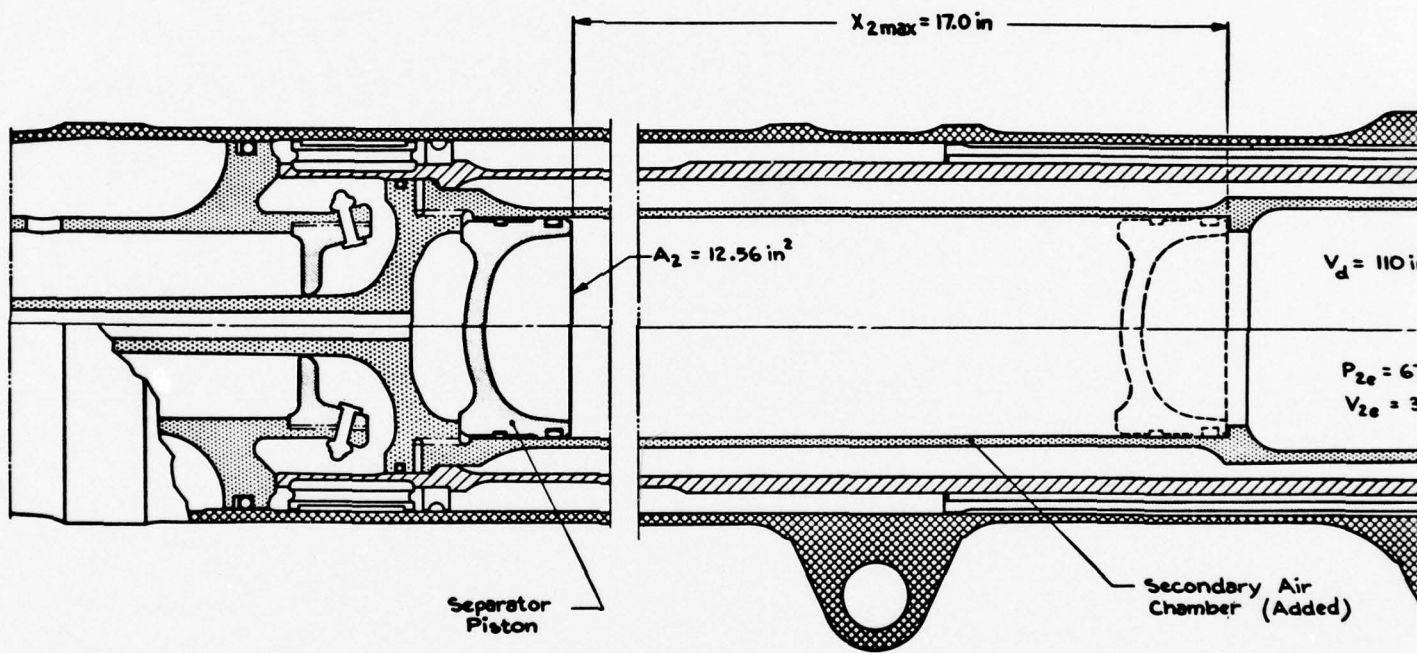
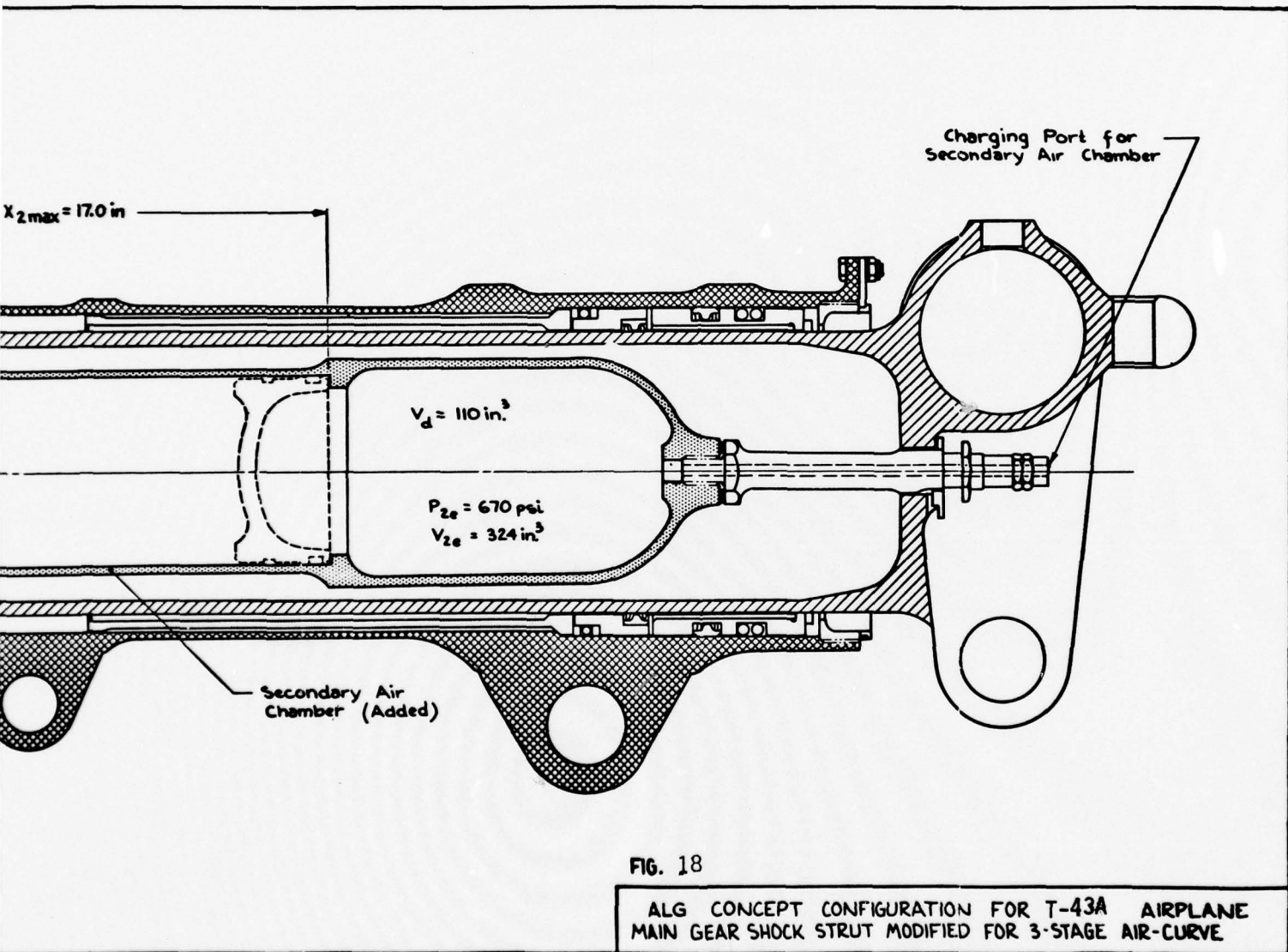

FIG. 17 ALG CONCEPT CONFIGURATION FOR T-43A-AIRPLANE. PROPOSED 3-STAGE AIR-CURVE



1



2

5.0 PAYOFF ANALYSIS

A landing gear which is designed to reduce the dynamic taxi loads which are transmitted into the air frame will allow the airplane to negotiate and survive rougher fields and taxi over larger obstacles without incurring structural damage. Also, a longer life can be anticipated for certain structural elements of the air frame with the improved landing gear when it is exposed repeatedly to runways of abnormal roughness. Both of these payoff areas have been evaluated and a quantitative assessment of each has been made.

5.1 Survivability

The term survivability applies to the landing gear and air frame being able to negotiate certain defined discrete obstacles which could be encountered on bomb repaired runways and forward bases during wartime operation. Three distinct runway obstacles were selected. Included were a representation of a hastily repaired bomb crater in a concrete runway, a rectangular bump and dip representing a loose block of pavement or a sharp trough in a concrete runway, and a series of five unevenly spaced ruts resulting from airplane taxi operations on semi-prepared or unprepared runways.

5.1.1 Simulated Conditions

Landing gear survivability was assessed by determining the vertical and horizontal landing gear loads that occur while encountering various discrete obstacles.

For each airplane, the potential for improved landing gear survivability was evaluated by a comparison between the critical gear loads as obtained with the existing gears and the loads as obtained with an adaptive gear configuration.

A summary of the operating conditions that were simulated is given in Table 4.

5.1.2 Encounter with Repaired Bomb Damaged Runway

Hastily repaired bomb damage was simulated as shown in Figure 19. This idealized cross-section represents a repaired bomb crater on a concrete runway. The upheaved pavement is a section of unremoved runway which has been raised by laterally displaced soil caused by the explosion of the bomb. The applied repair method is described in AF Regulation 98-2, Disaster Preparedness and Base Recovery Planning, 29 July 1974, and consists of back-filling the crater with the ejecta, topping it off with select fill material, and placing the AM-2 aluminum mat over the filled crater. The depression in the center of the mat represents the effect of grading tolerances, settling and repeated traffic loads over the aluminum mat.

The upheaval height H_u was chosen as the parameter to be varied. The airplane was rolled over this idealized obstacle at speeds of 20, 40, 60, 80 and 100 KTS. At each speed, the upheaval height was increased gradually up to the point at which loads equal to the design limit load of the gear were reached.

The results of these runs are summarized in Figure 20. The allowable upheaval height of the YC-14 airplane is approximately three times larger than that of the KC-135. This illustrates the superior performance of the YC-14 landing gear. The dashed lines in Figure 20 indicate the increase in allowable upheaval height that would be obtained by going to an adaptive gear and shows that for almost all velocities the adaptive gear can negotiate higher upheaval heights than the conventional gear. The adaptive gear simulated for the YC-14 is the dual mode damping configuration and the three stage air curve oleo for the KC-135.

TABLE 4 SIMULATED CONDITIONS FOR SURVIVABILITY ANALYSIS

AIRPLANE	GROSS WEIGHT (KIPS)	AIRPLANE VELOCITY (KTS)	MAIN LANDING GEAR CONFIGURATION	RUNWAY CHARACTERIZATION
YC-14	150	100, 80, 60, 40, 20	Baseline	Idealized Repaired Crater
YC-14	150		Dual Mode Damping	
KC-135	297		Baseline	
KC-135	297		3-Stage Aircurve	
YC-14	150	50	Baseline	Rectangular Bump or Dip Representing Upheaved Concrete Slab
YC-14	150		Dual Mode Damping	
KC-135	297		Baseline	
KC-135	297		3-Stage Aircurve	
YC-14	150	100, 80, 60, 40, 20	Baseline	Ruts Across Runway
YC-14	150		Dual Mode Damping	
KC-135	297		Baseline	
KC-135	297		3-Stage Aircurve	

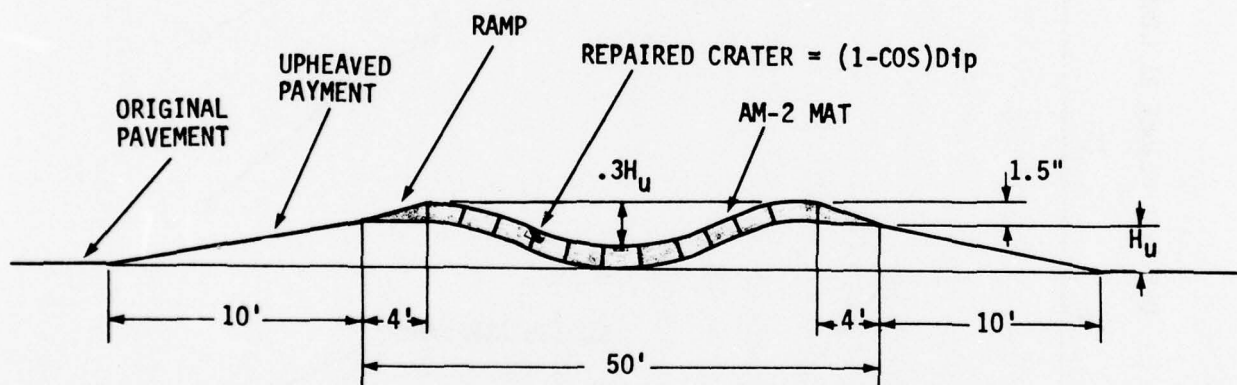

FIGURE 19 IDEALIZED REPRESENTATION OF HASTILY REPAIRED BOMB CRATER

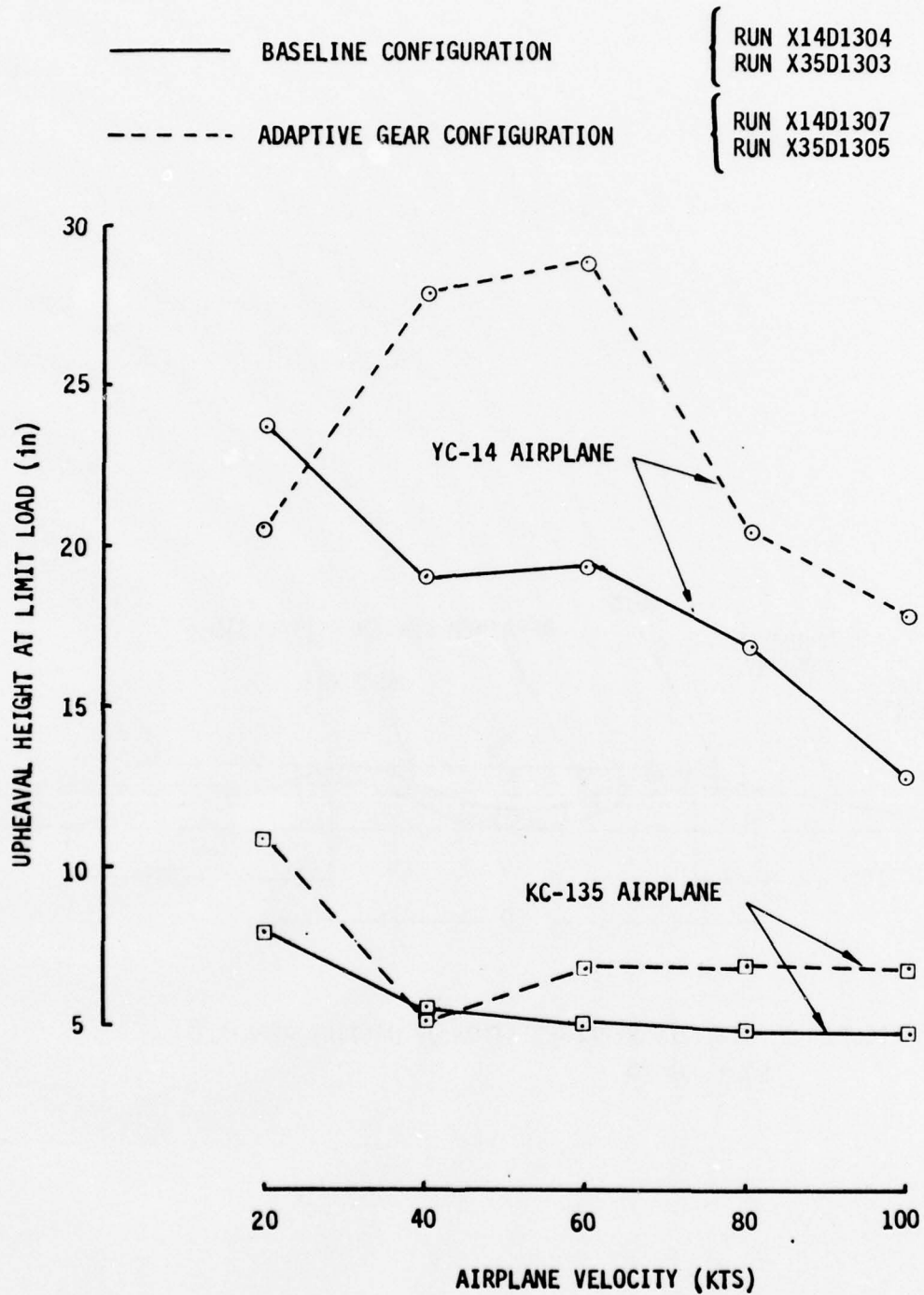

FIG. 20 PERFORMANCE COMPARISON YC-14 VS. KC-135 FOR ENCOUNTER WITH 50 FT. REPAIRED CRATER

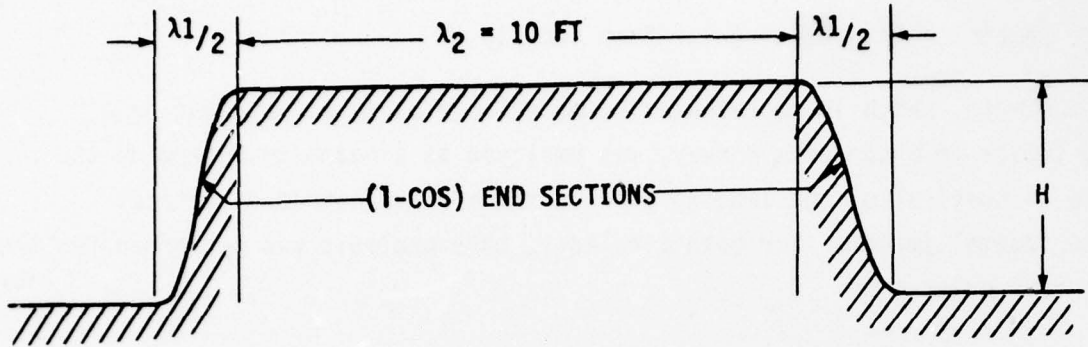

FIGURE 21 IDEALIZED REPRESENTATION OF RECTANGULAR BUMPS OR DIP

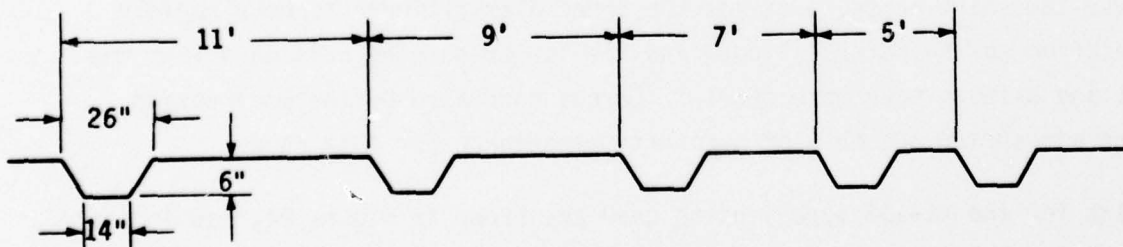

FIGURE 22 IDEALIZED REPRESENTATION OF RUTTED RUNWAY

5.1.3 Encounter with Rectangular Bump and Dip

This obstacle, which is representative of a loose block of pavement or a sharp trough on a concrete runway, was employed as a means to determine the limits of survival of the landing gear during a sharp combined vertical and horizontal impact. For both airplanes, this analysis was performed for the main gears only.

The length of surface elevation transition for these obstacles are short compared to the tire footprint, therefore, these runs were made with the pneumatic tire model. Both vertical and horizontal forces were considered.

The obstacle height H was chosen as the parameter to be varied. The ratio of obstacle height to wave half length $\lambda/2$ was fixed at a value of 2.0. The length of the obstacle was held constant at 10 feet. All runs were made at an airplane forward speed of 50 KTS. At this speed the aerodynamic lift is not excessive and the gear is still heavily loaded. However, the speed is high enough to generate a sharp tire impact.

Results for the YC-14 type landing gear are shown in Figure 23. For each obstacle height the maximum computed vertical and horizontal forces are shown. It should be noted that these maximum values do not necessarily occur at the same time. Results indicate that both vertical and horizontal loads can be significantly reduced with the dual mode damping configuration. This is so because the sharp obstacle causes the inner oleo cylinder to move rapidly in relation to the outer cylinder and the larger damping orifice allows the wheel and axle to move more freely. Forces generated by the compression of the air spring are only of secondary importance for this case.

Results for the KC-135 type landing gear are shown in Figure 24, and indicate that the adaptive gear can do very little to reduce vertical and horizontal loads. It must be remembered that the KC-135 adaptive gear configuration consists of a dual mode air spring while the damping orifices were not modified.

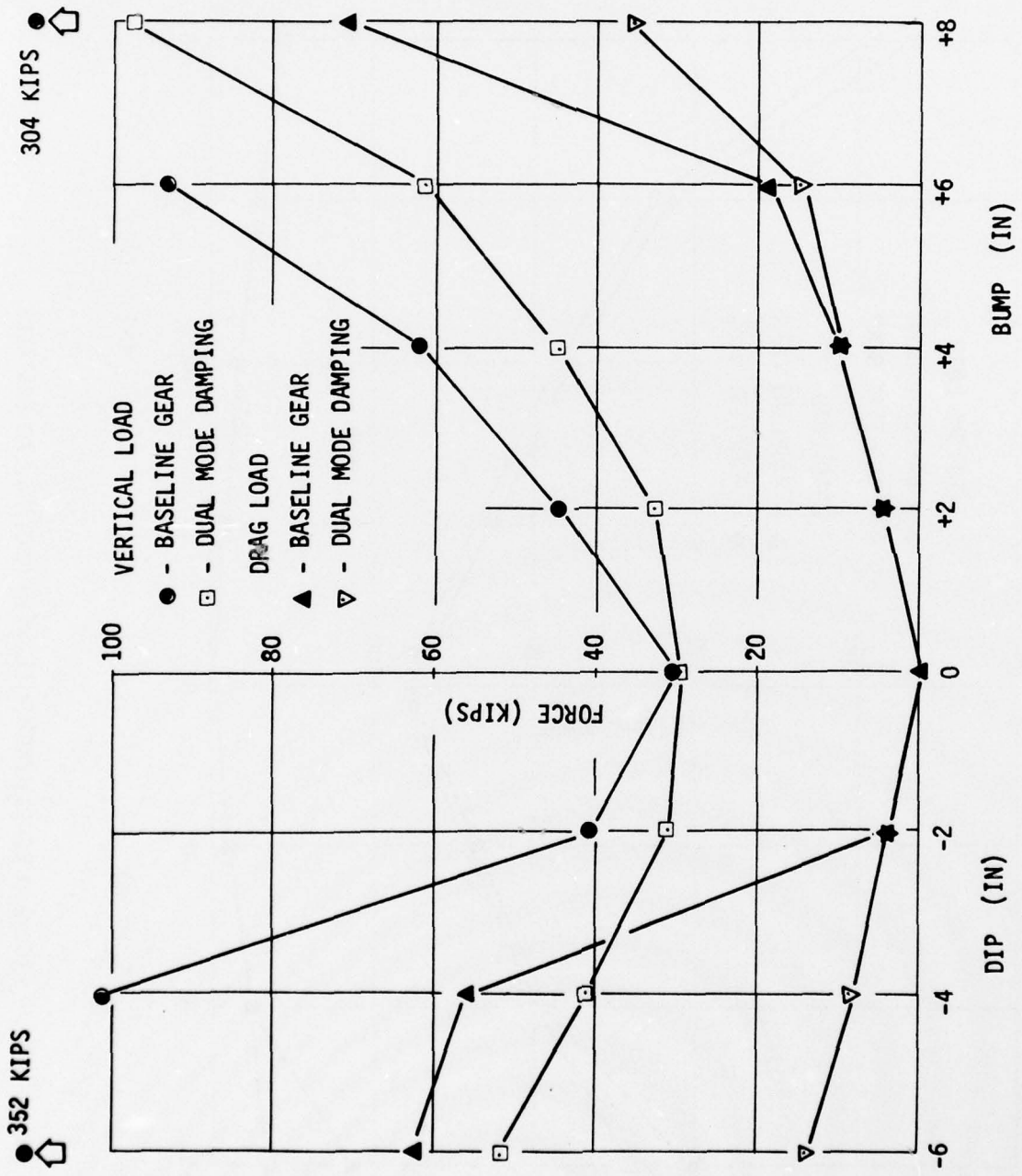

FIGURE 23 YC-14 ENCOUNTER WITH RECTANGULAR OBSTACLE, AIRPLANE VELOCITY = 50KTS

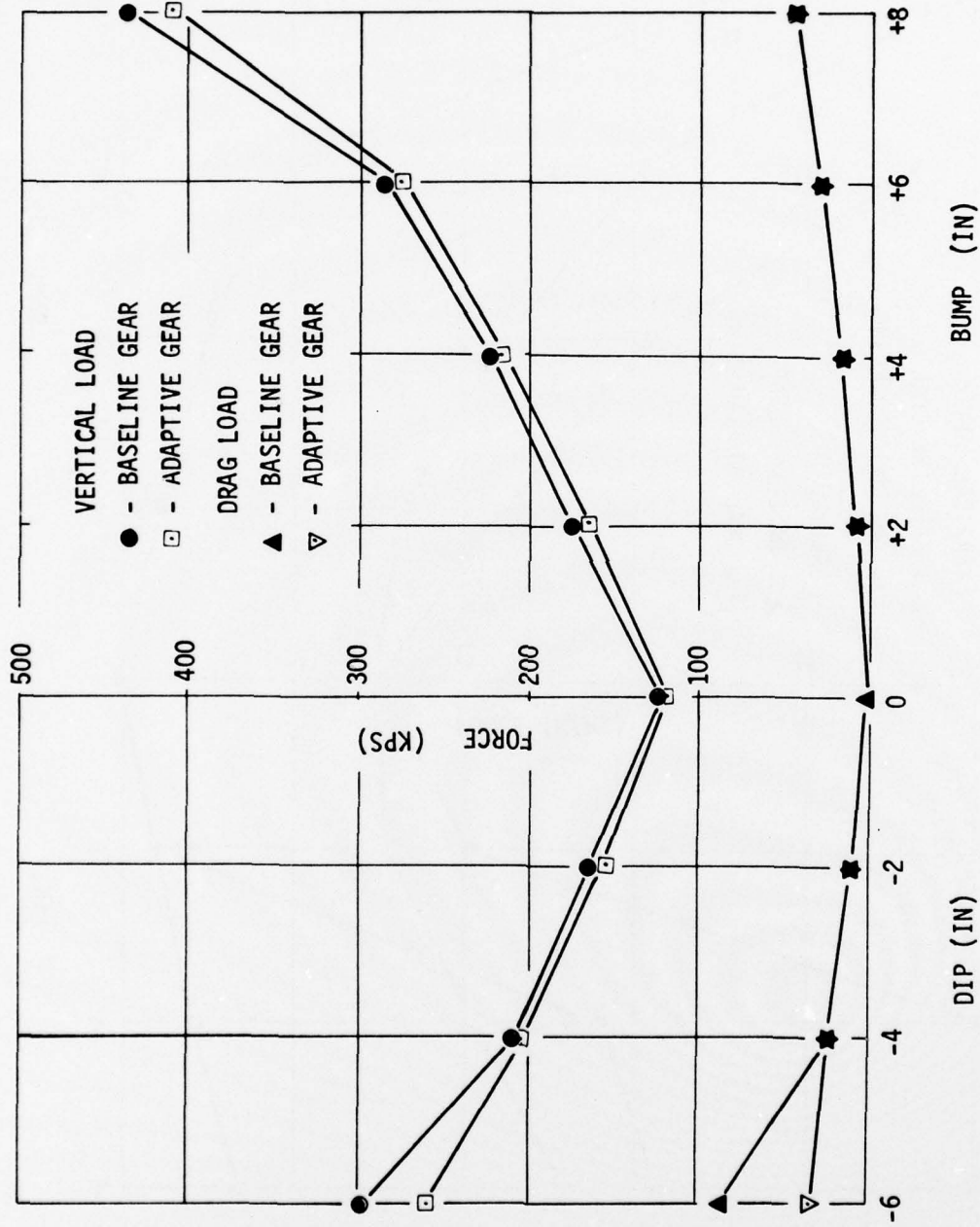

FIGURE 24 KC-135 ENCOUNTER WITH RECTANGULAR OBSTACLE

The effect then is the reverse as that experienced in the YC-14 calculations. Damping forces which are the major contributor to these dynamic loads, are not reduced and the modified air spring contributes only very little in decreasing the total vertical and horizontal forces.

5.1.4 Encounter with Rutted Runway

This obstacle represents tire ruts generated on semi-prepared and unprepared runways resulting from airplane taxi operations. The obstacle is a series of 5 consecutive ruts, spaced as shown in Figure 22.

For both airplanes, encounter with this obstacle was simulated at airplane speeds of 100, 80, 60, 40 and 20 knots.

Figure 25 shows the results for the YC-14 airplane. For each value of the airplane velocity, the maximum horizontal and vertical loads were determined and plotted as shown. The loads are in all cases well below the limit load, indicating that the rutted runway as defined above can easily be negotiated. As speed increases the frequency of disturbance increases and the wheel and brake inertia starts acting as a seismic mass and transmits only relatively little dynamic vertical and horizontal load. The tire, however, is being worked much harder. Due to the high frequency excitation the adaptive gear performance is nearly identical to that of the conventional landing gear.

Figure 26 shows the results for the KC-135 airplane. For an airplane velocity of 100 KTS, the load is below limit load, for all other velocities 80, 60, 40, and 20 KTS, the loads are all above limit load.

Therefore, the KC-135 cannot negotiate the imposed obstacle at any speed below 100 KTS. It should be noted that there is no appreciable difference between the baseline and the Adaptive Gear configuration.

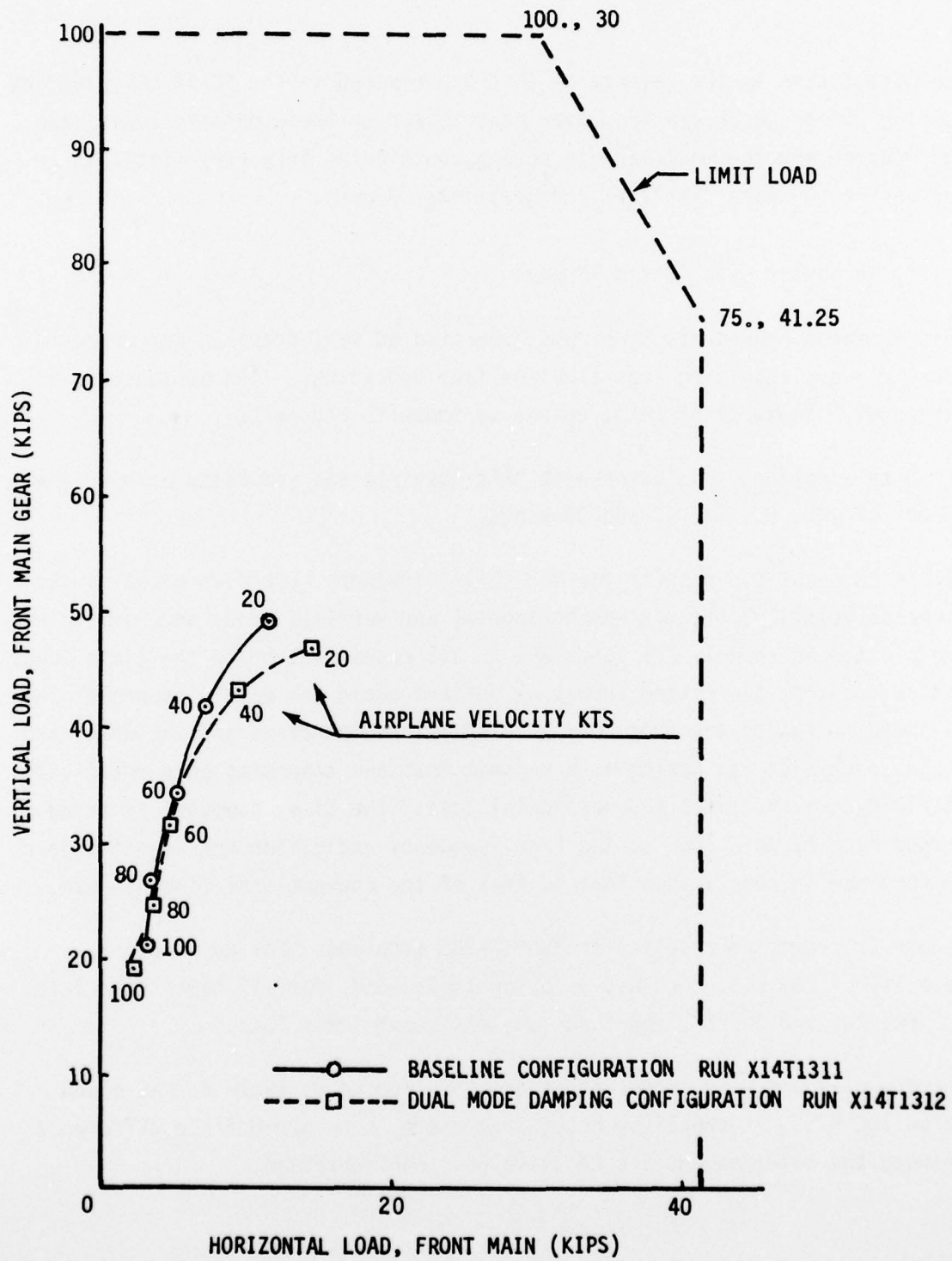

FIGURE 25 YC-14 ENCOUNTER WITH RUTTED RUNWAY

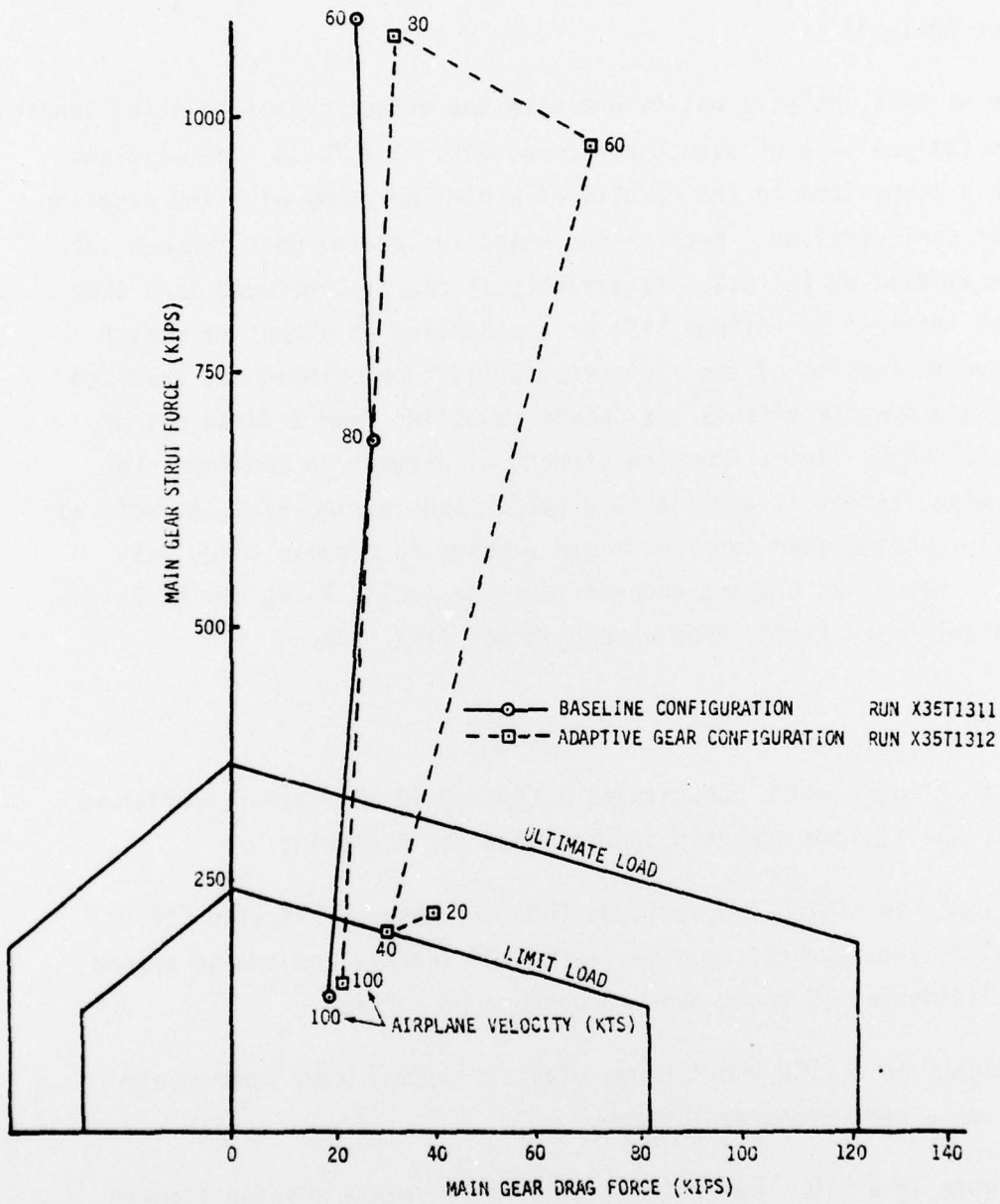

FIGURE 26 KC-135 ENCOUNTER WITH RUTTED RUNWAY

5.2 Fatigue Analysis

The purpose of this analysis was to evaluate the effect of the adaptive landing gear on the fatigue life of structural components of a YC-14 type airplane and to make a comparison to the results of a similar study with the baseline landing gear configuration. Because the adaptive landing gear reduces the airframe excitation at the C.G., intuitively it can be concluded that there should be an increase in fatigue life or a reduction in structure damage caused by cyclic loading of the airframe. It must be pointed out that due to location and dynamic effects the damage resulting from a fixed set of outside disturbances varies from one structural element to another. For example, a wing element is exposed to dynamic loads during taxi, as well as flight, while landing gear components are exposed to dynamic loads only during taxi. Hence, an element exposed to large cyclic loads during flight, can benefit only very little from a very smooth taxi ride.

5.2.1 Method

A block of 16 flights which constitutes a typical YC-14 mission profile was selected for the fatigue analysis and included the following:

- o Three flights in a STOL low altitude (500 ft) resupply mission (143NM) with landing and take-off on a semi-prepared surface and two 10 second taxi conditions at 15 knots over an unprepared surface.
- o Three flights in a STOL short range mission (345NM) with landing and take-off on a semi-prepared surface.
- o Four flights in a CTOL low altitude (500 ft) resupply mission (143NM) with landing and take-off on a prepared surface.
- o Five flights in a CTOL short range mission (332NM) with landing and take-off on a prepared surface.

- o One flight in a CTOL long range mission (1977Nm) with landing and take-off on a prepared surface.

Damage predictions were made per standard Boeing durability procedures and required the identification of all stress time histories for each mission segment such as taxi, departure, climb, cruise, descent, etc. Two structural details which are exposed to taxi induced dynamic loads were selected for this analysis, and included the wing upper surface skin-stringer attachment shown on Figure 27 and the landing gear lever beam shown on Figure 28.

This fatigue analysis was conducted analyzing details which were designed for the required YC-14 usage. Considering the assumptions made for this analysis, it is believed that the ratios of the damage predictions of the adaptive/baseline gears are valid for the assumed mission mix.

5.2.2 Results

The results of the fatigue analysis are shown for the wing upper surface attachment on Table 5. Calculated damage resulting from taxi conditions is shown separately. In this way, the actual contribution of the taxi segment can be clearly identified. It is evident that damage resulting from taxi over prepared surfaces is three order of magnitudes smaller than damage resulting from all other mission segments. However, taxi damage on unprepared surfaces can be significant in comparison to all other mission segments and the adaptive landing gear can result in noticeable reduction of total damage. In case of the STOL short range mission, this reduction is 15.8%. For the STOL low altitude resupply, the reduction is only 3.6% because low level gusts during flight increase total damage substantially. Overall reduction in damage for all 16 flights per 100,000 blocks is 2.5%.

Results for the landing gear lever beam are shown on Table 6. Again, the calculated damage values indicates that taxi over prepared surfaces are insignificant in comparison to all other mission damage. However, taxi over semi-prepared surfaces causes damage which is significant. Also, in these cases

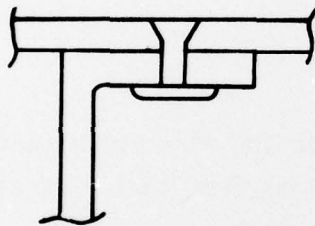
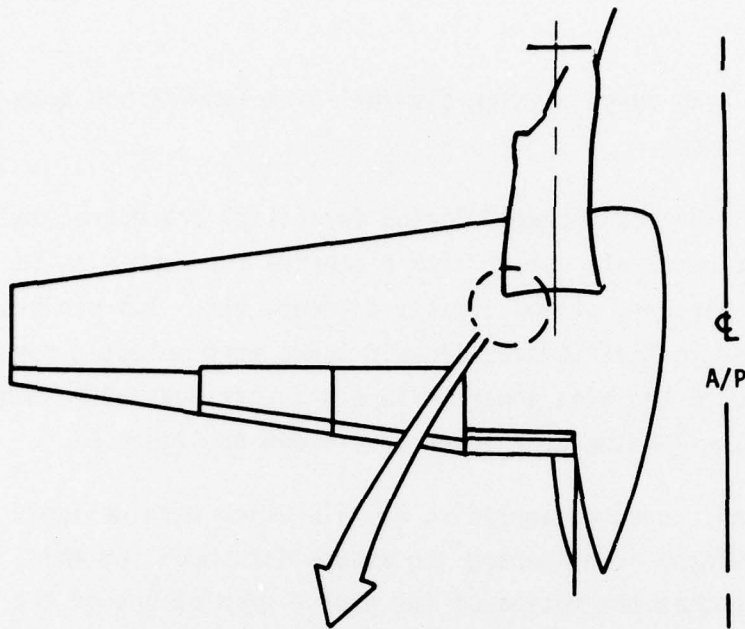

SKIN: 7075-T651
 STRINGER: 7075-T651
 FASTENER: 2024 5/16" DIA.

FIGURE 27 WING UPPER SURFACE SKIN - STRINGER ATTACHMENT

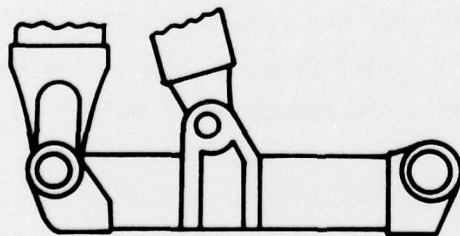

54 4340 VACUUM MELT STEEL
 BMS 7-26 CLASS I (275-300 KSI HT)

FIGURE 28 LANDING GEAR LEVER BEAM

TABLE 5 WING UPPER SURFACE DETAIL DAMAGE



TAXI CONDITION	ONE CTOL LONG RANGE	FOUR CTOL LO ALTITUDE RESUPPLY	THREE STOL LO ALTITUDE RESUPPLY	FIVE CTOL SHORT RANGE	THREE STOL SHORT RANGE
	PREPARED SURFACE	PREPARED SURFACE	SEMI PREPARED; UNPREPARED AT 15KN FOR 20 SEC	PREPARED SURFACE	SEMI PREPARED SURFACE
TAXI DAMAGE PER 100,000 BLOCKS	1.64x10 ⁻⁴ 1.2x10 ⁻⁴	6.56x10 ⁻⁴ 4.8x10 ⁻⁴	.074 .140	8.2x10 ⁻⁴ 6.0x10 ⁻⁴	.053 .111
DAMAGE DUE TO ALL OTHER MISSION SEGMENTS PER 100,000 BLOCKS	.297	9.166 9.166	6.025 6.190	.979	1.133 1.293
TOTAL DAMAGE PER 100,000 BLOCKS	.297 .297	9.167 9.167	6.099 6.330	.980 .980	1.1866 1.410
 INCLUDES FLIGHT, GROUND-AIR-GROUND, REVERSE THRUST	DAMAGE ALL FLIGHTS PER 100,000 BLOCKS	17.730	18.185	ADAPTIVE	BASELINE

TABLE 6 LANDING GEAR LEVER BEAM DAMAGE

TAXI CONDITION	ONE CTOL LONG RANGE	FOUR CTOL LO ALTITUDE RESUPPLY	THREE STOL LO ALTITUDE RESUPPLY	FIVE CTOL SHORT RANGE	THREE STOL SHORT RANGE
	PREPARED SURFACE	PREPARED SURFACE	SEMI PREPARED UNPREPARED AT 15KN FOR 20 SEC	PREPARED SURFACE	SEMI PREPARED SURFACE
TAXI DAMAGE PER 100,000 BLOCKS	.65 1724.35	2.61 6897.36	566.27 1667.69	3.26 1381.88	537.83 1667.62
DAMAGE DUE TO  ALL OTHER MISSION SEGMENTS PER 100,000 BLOCKS	.48 1724.53	1.91 6898.14	855.86 1633.38	2.39 1382.37	802.13 1588.18
TOTAL DAMAGE PER 100,000 BLOCKS	1724.99 1725.01	6899.97 6900.06	2233.97 2489.25	1385.15 1384.77	2205.45 2390.31
 INCLUDES GROUND-AIR-GROUND, TOUCHDOWN AND BRAKING	DAMAGE ALL FLIGHTS PER 100,000 BLOCKS	14449.54	14889.41	ADAPTIVE	BASELINE

the adaptive gear configuration results in a noticeable overall damage reduction. For the STOL low altitude resupply mission and STOL short range mission, the reduction is 10% and 7.7% respectively. Overall reduction in damage for all 16 flights per 100,000 blocks is 2.9%.

A summary of the fatigue analysis is shown on Table 7 and shows the damage reduction for the two structural components. It is evident that the adaptive landing gear reduces fatigue damage when austere field conditions prevail. Taxi over prepared fields, however, is smooth from the start and the adaptive gear can, of course, do little to improve an already acceptable condition.

TABLE 7 YC-14 DAMAGE REDUCTION DUE TO ADAPTIVE GEAR

	AUSTERE FIELD: 6 MISSIONS	PREPARED FIELD: 10 MISSIONS	ALL 16 MISSIONS
WING UPPER SURFACE SKIN-STRINGER ATTACHMENT	5.9%	0	2.5%
LANDING GEAR LEVER BEAM	9.0%	0	2.9%

6.0 CONCLUSIONS AND RECOMMENDATIONS

Several configurations for an adaptive landing gear have been defined. The approach was to use simple hardware techniques such as modifying the air curve, the metering pin, and the rebound orifice to reduce the CG RMS acceleration when taxiing over semi-prepared and unprepared runways. The study was conducted for T-43A, KC-135 and YC-14 type main landing gears.

Landing gears for the KC-135 and T-43A are of conventional design consisting of a single stage air curve which is sized for static load requirements and a metering pin which is designed to result in the most favorable dynamic oleo load-stroke curve at high airplane sink rates. Results of this study indicate that the dynamic taxi loads for such an oleo are transmitted to the airframe primarily by the air spring. As a result a reduction in air spring stiffness lowered the CG RMS acceleration from .098 G RMS to .074 G RMS for the KC-135 and from .152 G RMS to .135 G RMS for the T-43A when taxiing over prepared runways. Further studies indicated that loads induced by taxiing over repaired bomb craters could be reduced with the softer gear. For the KC-135, however, a rectangular bump or dip as well as a rutted runway result in vertical and horizontal gear loads which do not depend on the selected oleo stiffness. Hardware modifications required for the T-43A and KC-135 type landing gears for softening of the air spring requires a two stage oleo design which can be incorporated into the existing gear envelope without major difficulty. Such a modification would result in a different metering pin profile and poorer touchdown dynamics (i.e., more rebound) because the modified air curve would store more potential energy during compression.

The landing gear for the YC-14 was designed for high sink rates and to operate on austere airfields. This is exemplified in a design with a long axle stroke and a two stage air curve. The taxi analysis indicates that

the CG RMS accelerations can be reduced from 0.245 to .185 with a modified metering pin bypass orifice and a larger rebound orifice. A further decrease in CG RMS acceleration to .13 results when the stiffness of the second stage air curve is reduced and adjusted in response to aircraft weight. The hardware implementation of the orifice modification is simple and can be incorporated into the baseline landing gear in such a way that it is active only during taxi, but not at touchdown. The hardware concept which is required to adapt the second stage air curve to airplane weight indicates this further refinement to be of questionable value due to the required complexity. The dual mode damping concept is, therefore, the recommended modification to the YC-14 type landing gear. The payoff studies for the gear with dual mode damping indicate that obstacles such as repaired bomb craters on prepared runways and rectangular bumps and dips can be negotiated by the airplane with reduced vertical and horizontal gear loads. Rutted runways generate taxi loads of similar magnitude when the baseline gear is compared to the gear with the dual mode damping device. The adaptive landing gear can lead to a measureable reduction in fatigue damage for certain structural members when missions to and from austere runways are the sole considerations. If, however, taxi over prepared runways is included into the fatigue analysis, then the reduction in damage is only marginal.

The conclusion to the study of T-43A and KC-135 type gears can be summarized as follows:

1. Taxi induced acceleration of the airplane center of gravity is small for conventional landing gears operating on prepared runways.
2. Simple adaptive concepts such as modified oleo spring rate can reduce these small accelerations slightly.
3. The adaptive concept helps to reduce taxi loads induced by ground obstacles of medium wave length (bomb repaired craters).

For the YC-14 type gear, the following conclusions can be made:

1. Taxi performance improvements can be made to a dual stage oleo, long stroke gear by a reduction of damping forces.
2. This reduction of damping forces also allows the airplane to negotiate larger bomb repair craters, higher bumps, and deeper dips.
3. Fatigue analysis indicates that the adaptive gear causes noticeable lower structural damage for missions from and to semi and unprepared runways.

It is recommended that hardware development for the YC-14 type landing gear with the dual mode damping device be initiated. It is also recommended that a similar study should be made for fighter type landing gears with special emphasis on survivability over bomb repaired craters.