



AD A 053760

AFAPL-TR-78-3

18-22

# EVALUATION OF SOLID LUBRICATED BEARINGS UTILIZING CARBONIZED PHENOLIC COMPOSITE CAGES

*LUBRICATION BRANCH  
FUELS AND LUBRICATION DIVISION*

JANUARY 1978

TECHNICAL REPORT AFAPL-TR-78-3  
Interim Report for Period August 1976 to January 1977

DDC  
RECEIVED  
MAY 11 1978  
F

Approved for public release; distribution unlimited.

AIR FORCE AERO PROPULSION LABORATORY  
AIR FORCE WRIGHT AERONAUTICAL LABORATORIES  
AIR FORCE SYSTEMS COMMAND  
WRIGHT-PATTERSON AIR FORCE BASE, OHIO 45433

DDC FILE COPY

NOTICE

When Government drawings, specifications, or other data are used for any purpose other than in connection with a definitely related Government procurement operation, the United States Government thereby incurs no responsibility nor any obligation whatsoever; and the fact that the Government may have formulated, furnished, or in any way supplied the said drawings, specifications, or other data, is not to be regarded by implication or otherwise as in any manner licensing the holder or any other person or corporation, or conveying any rights or permission to manufacture, use, or sell any patented invention that may in any way be related thereto.

This report has been reviewed by the Information Office (IO) and is releasable to the National Technical Information Service (NTIS). At NTIS, it will be available to the general public, including foreign nations.

This technical report has been reviewed and is approved for publication.

  
JOHN B. SCHRAND  
Project Engineer

  
R. D. DAYTON  
Project Engineer

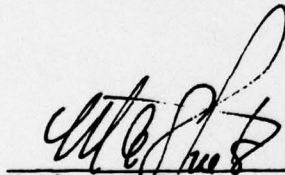
  
M. A. SHEETS  
Project Engineer

  
HOWARD F. JONES, Chief  
Lubrication Branch

FOR THE COMMANDER

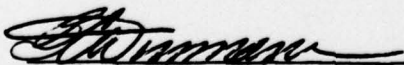
  
B. C. DUNNAM, Chief  
Fuels and Lubrication Division

Copies of this report should not be returned unless return is required by security considerations, contractual obligations, or notice on a specific document.

UNCLASSIFIED

SECURITY CLASSIFICATION OF THIS PAGE (When Data Entered)

22

14

6

10

REPORT DOCUMENTATION PAGE

READ INSTRUCTIONS BEFORE COMPLETING FORM

1. REPORT NUMBER AFAPL-TR-78-3		2. GOVT ACCESSION NO.	3. RECIPIENT'S CATALOG NUMBER
4. TITLE (and Subtitle) Evaluation of Solid Lubricated Bearings Utilizing Carbonized Phenolic Composite Cages.		5. TYPE OF REPORT & PERIOD COVERED Interim Report, <del>for</del> August 1976 to January 1977	
7. AUTHOR(s) John B. Schrand <del>ASPL</del> , Ronald D. Dayton <del>ASFL</del> , Mac A. Sheets <del>ASFF</del>		6. PERFORMING ORG. REPORT NUMBER	
9. PERFORMING ORGANIZATION NAME AND ADDRESS Air Force Aero Propulsion Laboratory/SFL Air Force Wright Aeronautical Laboratories Air Force Systems Command Wright-Patterson Air Force Base, Ohio 45433		8. CONTRACT OR GRANT NUMBER(s)	
11. CONTROLLING OFFICE NAME AND ADDRESS Air Force Aero Propulsion Laboratory WPAFB, Ohio 45433		10. PROGRAM ELEMENT, PROJECT, TASK AREA & WORK UNIT NUMBERS 30480619	
14. MONITORING AGENCY NAME & ADDRESS (if different from Controlling Office)		12. REPORT DATE January 1978	
		13. NUMBER OF PAGES 43 P.	
		15. SECURITY CLASS. (of this report) Unclassified	
16. DISTRIBUTION STATEMENT (of this Report) Approved for Public Release; Distribution Unlimited		15a. DECLASSIFICATION/DOWNGRADING SCHEDULE	
17. DISTRIBUTION STATEMENT (of the abstract entered in Block 20, if different from Report)			
18. SUPPLEMENTARY NOTES			
19. KEY WORDS (Continue on reverse side if necessary and identify by block number) Composites, Self Lubricating Bearing Design Lubrication, Solid Film Solid Lubricants Carbonized Phenolic Resin			
20. ABSTRACT (Continue on reverse side if necessary and identify by block number) Solid lubricated bearings utilizing a carbonized phenolic resin composite cage have been evaluated. Functional tests using 204 size bearings were run under ambient conditions at speeds up to 10,000 rpm. The average life of the five bearings tested was 18 1/4 hours with the maximum life being less than 50 hours. No further testing of these particular materials is anticipated.			

DDC  
RECEIVED  
MAY 11 1978  
F

hc

011574

FOREWORD

This report describes an in-house effort conducted by personnel of the Lubrication Branch (SFL), Fuels and Lubrication Division (SF), Air Force Aero Propulsion Laboratory, Air Force Wright Aeronautical Laboratories, Wright-Patterson Air Force Base, Ohio, under project 3048, "Fuels, Lubrication and Fire Protection," Task 304806, "Aerospace Lubrication," Work Unit 30480619, "Bearing Research for Propulsion and Power Systems."

The work reported herein was performed during the period 1 Aug 76 to 31 Jan 77, under the direction of the authors, John B. Schrand (AFAPL/SFL), R. D. Dayton (AFAPL/SFL), M. A. Sheets (AFAPL/SFF), project engineers. The report was released by the authors in September 1977.

Acknowledgement is hereby given to Mr. C. W. Smiley and Mr. S. R. Jackson for the conduct of the reported tests and for their otherwise very generous support to this program; to Mr. D. B. Elkins who balanced the solid lubricated bearing retainers and test rig drive shaft, and to various members of the AFAPL Zone Shop (AMFZA) who supported our effort through the fabrication and modification of various required items.

ACCESSION FOR	
NTIS	Write Section <input checked="" type="checkbox"/>
DOC	Buy Section <input type="checkbox"/>
UNANNOUNCED	<input type="checkbox"/>
JUSTIFICATION	
BY	
DISTRIBUTION/AVAILABILITY CODES	
Dist.	SPECIAL
A	

PRECEDING PAGE BLANK-NOT FILMED

## TABLE OF CONTENTS

<u>SECTION</u>	<u>PAGE</u>
I INTRODUCTION	1
II DESCRIPTION OF TEST RIG	3
III TEST PROCEDURE	11
IV DISCUSSION OF RESULTS	13
V CONCLUSIONS AND RECOMMENDATIONS	24
REFERENCES	25
APPENDIX	27

## LIST OF ILLUSTRATIONS

<u>FIGURE</u>	<u>PAGE</u>
1 SOLID LUBE BEARING TEST FACILITY CONSOLE	4
2 SOLID LUBE BEARING TEST FACILITY RIG	5
3 SCHEMATIC OF ROLLING ELEMENT BEARING TEST RIG	6
4 BASIC 204 SIZE TEST BEARING GEOMETRY	8
5 SIZE 204 CAGE DESIGN USING DOUBLE "L" SHROUD	9
6 FAILED CAGE FROM TEST #2	14
7 VARIATION OF OUTER RACE TEMPERATURE - TEST #1	15
8 VARIATION OF OUTER RACE TEMPERATURE - TEST #2	16
9 PHOTOGRAPH OF A TYPICAL SHROUDED RETAINER AFTER FAILURE	17
10 VARIATION OF OUTER RACE TEMPERATURE - TEST #3	18
11 VARIATION OF OUTER RACE TEMPERATURE - TEST #4	19
12 VARIATION OF OUTER RACE TEMPERATURE - TEST #5	20
13 VARIATION OF AVG. BRG. O.R. TEMP WITH SHAFT ROTATIONAL SPEED FOR BRGS WITH WGI, AgHg, AND CPR COMPOSITE RETAINERS	22
14 VARIATION OF AVG. BRG. TORQUE WITH SHAFT ROTATIONAL SPEED FOR BEARINGS WITH WGI, AgHg, AND CPR COMPOSITE RETAINERS	23

## SECTION I

### INTRODUCTION

Rolling element bearings of future high performance aerospace propulsion systems will operate at environmental conditions that may well exceed the capabilities of current technology. One aspect of technology in which advances must certainly be made is in the area of lubricant development and lubrication techniques required for these bearings. Today's conventional lubricants will not, in many cases, meet the ever increasing requirements necessary to function effectively at high temperatures, high speeds and in extreme conditions such as oxidative or vacuum environments. As a result, it is necessary that other lubricants and lubrication techniques be developed to satisfy these requirements. One potential solution is the use of a self-lubricating retainer (cage) in a ball bearing, which provides a completely self-contained bearing-lubricant system.

The principle of operation for the self-contained bearing-lubricant system is the continuous metering of minute quantities of lubricant to the balls in sliding contact with the retainer. The balls, in turn, transfer this lubricant to the race grooves in which they are rolling. In this way, all critical load-bearing surfaces are coated with a thin, lubricating film.

The state-of-the-art of solid lubricated bearings has progressed to the point where they now offer potential for use in a wide range of applications where operating and environmental conditions are such that conventional lubricants cannot be used satisfactorily. Self-lubricating bearings are of a sacrificial nature in that the lubricant is gradually depleted during usage; therefore, their greatest potential is seen to be in those applications which have limited operating life requirements. These would include such things as small expendable engines, alternators, drones, missiles, remotely piloted vehicles, etc. However, most of these applications involve high speeds and/or high temperature conditions. These represent severe conditions under which the bearings must perform, and are also conducive to excessive bearing heat generation during operation.

The primary intent of this investigation was to evaluate two solid lubricant composites which were developed by Midwest Research Institute under contract to the Air Force Materials Laboratory (Ref. 1,2). These composites utilize a carbonized phenolic resin matrix (CPR) reinforced with graphite fibers and lubricating pigments of  $\text{MoS}_2$ , tetrafluoroethylene, and  $\text{Sb}_2\text{O}_3$ .

## SECTION II

### DESCRIPTION OF TEST RIG

#### 1. General

The basic test facility, which was designed and built by Southwest Research Institute, consists of an air turbine to drive the test bearing, a bearing chamber, an oil system (which obviously was not required for the solid lube tests), bearing loading system, bearing heater (which also was not utilized for these tests), and the necessary instrumentation and controls. Photographs of the test facility are shown in Figure 1 and 2.

#### 2. Basic Design

A detailed schematic of the rolling element bearing test rig is shown in Figure 3. The test bearing, A, is driven by the main shaft, B, which is powered by an air turbine, C. Air to the turbine is supplied by an auxiliary compressor via the nozzle ring, D. Externally-pressurized, orifice-compensated air bearings, having low friction characteristics at high speeds, are shown as E and F, and are employed to support the main shaft during operation. The outer race of the test bearing is supported in the test bearing holder, G, which is held in the test chamber, H. Thrust load is applied to the test bearing by the axial load piston, I, and radial load by the radial load pad, J. The test chamber is externally supported by two hydrostatic air bearings: the axial support pad, K, and the radial load pad, J, which serves a dual purpose in that it supports the test chamber in the radial direction on a hydrostatic air film and also applies a radial load through the air film to the test bearing. A shaft extension, L, extends through the test chamber lid and serves as the driver for the rotary transformer, M. The shaft extension, L, is hollow and provides a path for the electrical conductors from the inner race (test bearing) temperature transducer to the rotary transformer. A magnetic pickup, N, monitors the speed of the main shaft, B.

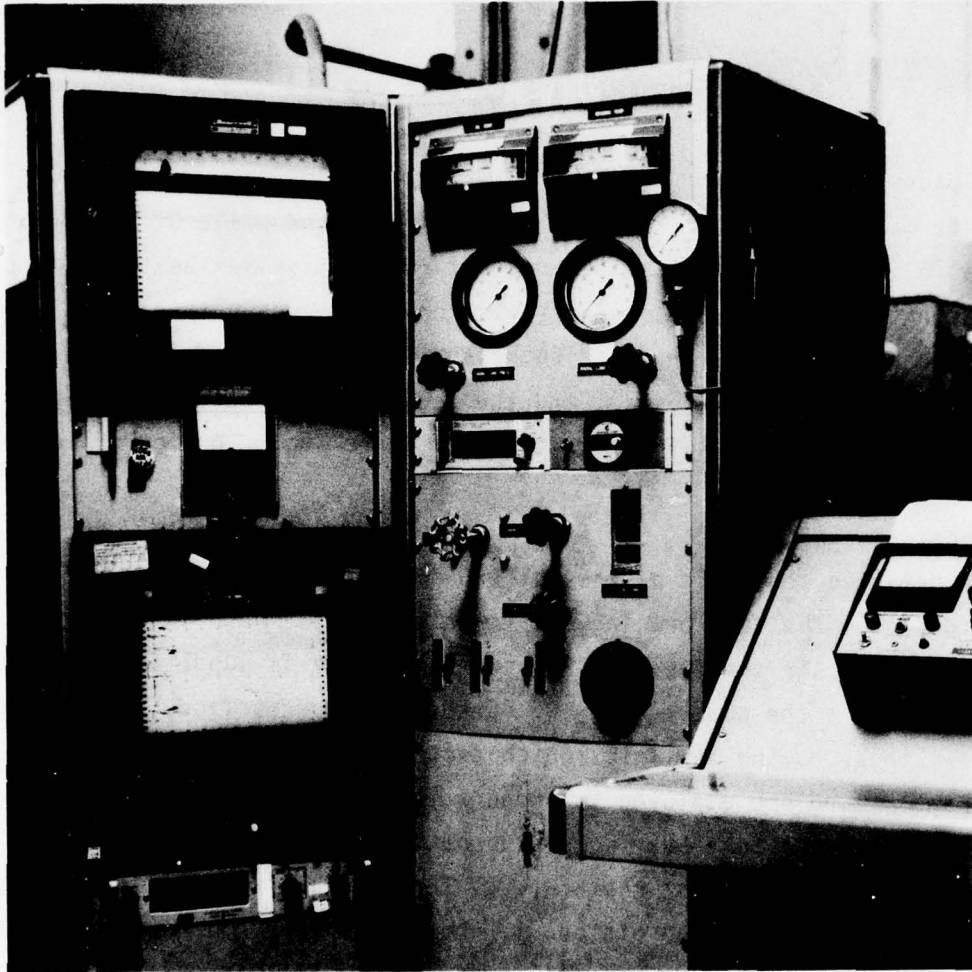

Figure 1. Solid Lube Bearing Test Facility Console

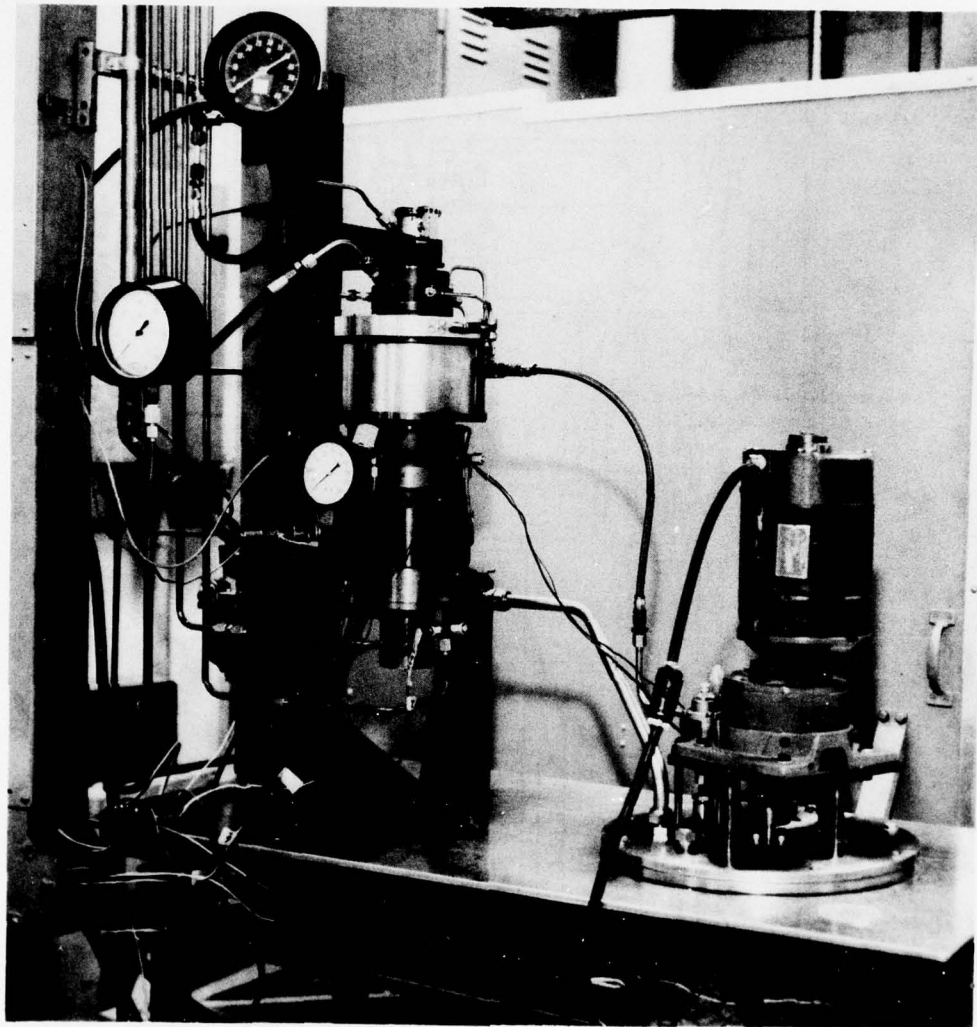

Figure 2. Solid Lube Bearing Test Facility Rig

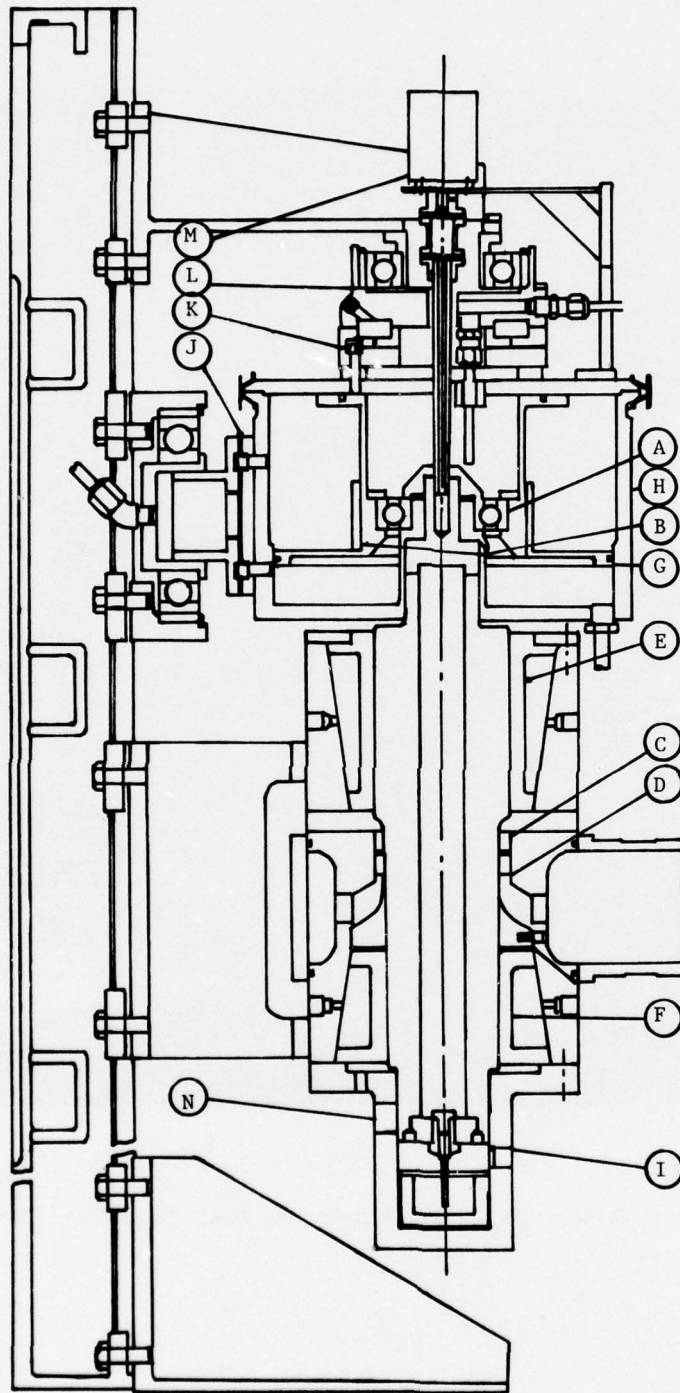

Figure 3. Schematic of Rolling Element Bearing Test Rig

### 3. Loading and Support System

The test rig was designed to allow the application of independently controlled thrust and radial loads on the test bearing. The thrust load, applied by means of the axial load piston, I, and the radial load applied by the radial load pad, J, are controlled with hand operated pressure regulators mounted in the instrument console. The amount of radial or thrust load is determined by the known piston size and the applied pressure which is indicated on the gauges in the instrument console.

Filtered air is supplied to the two support air bearings, E and F, through an air manifold. These bearings are orifice compensated and were designed to operate at 200 to 250 psig on clean dry air. Practical operating experience has shown that if the supply air is contaminated with either water or oil the high speed capability of the rig is severely reduced due to the deleterious effects of these contaminants on the solid lubricant coating which has been applied to the journal surface of the air bearings.

### 4. Bearing Torque Measurements

Torque due to test bearing friction, which tends to rotate the test chamber, H, is measured with strain gages which are attached to a metal leaf spring. The leaf spring deflects when torsional load is applied and produces a resistance change in the strain gage bridge, which in turn gives an electrical output that is calibrated and employed as a measure of bearing torque. Since the radial and axial hydrostatic air pads offer negligible torsional resistance, the indicated torque is an accurate measure of test bearing torque. The torque is indicated directly on a Sanborn Model 311A transducer amplifier, and recorded simultaneously on a Honeywell recorder.

### 5. Inner Race Temperature Measurement

Test bearing inner race temperature is measured with a sub miniature size surface type temperature transducer which is 0.25 in. x 0.20 in. x

0.04 in. thick. It is a low mass, platinum sensor with 100 ohms resistance at the ice point. The sensor is located in a machined cavity directly beneath the test bearing inner race. Centrifugal forces due to rotation of the main shaft force the sensor against the bore of the inner race and provide an inner race temperature measurement. Output from the transducer is coupled from the rotating shaft to a stationary location by employing a rotary transformer. From the transformer the temperature is indicated directly on a Himmelstein meter located in the instrument console.

#### 6. Drive System

The drive system consists of an air driven turbine, C, located approximately at the mid length of the main shaft, B. Air is supplied to the turbine by an auxiliary compressor via a nozzle ring, D. To obtain maximum design speed, which is 60,000 rpm, approximately 125 scfm of air at 100 psig is needed. Main shaft speed is monitored with an electronic tachometer mounted in the instrument console. Input to the tachometer is from a magnetic pickup whose interrupted signal is provided by 6 recesses located at the bottom most section of the main shaft.

#### 7. Test Bearings and Retainers

The basic ball bearing geometry, a 204 size bearing with a 20 mm bore, used to conduct the solid lubricated bearing tests is shown in Figure 4. Bearing clearances are presented in Table I. All of the test bearings were fabricated from M-2 tool steel and had ABEC-5 precision rating. Each bearing utilized eight balls which were 9/32 inches in diameter.

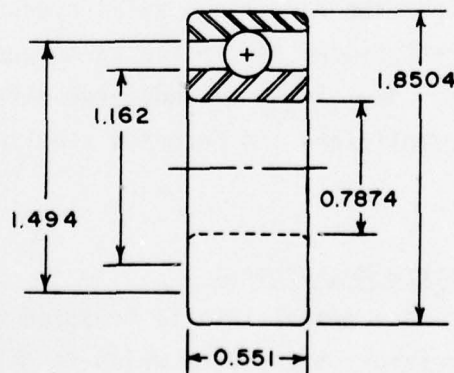

Figure 4. Basic 204 Size Test Bearing Geometry

TABLE I

BEARING CLEARANCES

Internal Clearance	0.010 inches	0.25 mm
Cage/Land Clearance	0.021 inches	0.53 mm
Ball/Hole Clearance	0.010 inches	0.25 mm
Contact Angle	25°	
Outer Race Curvature	0.60	
Inner Race Curvature	0.59	

The self-lubricating cages being evaluated in these bearings are an inner land riding design which were manufactured from two different carbonized phenolic resin composite materials. Each material was evaluated both with and without a double "L" 303 stainless steel reinforcing shroud assembly. A typical bearing cage with shroud attached is shown in Figure 5. Configuration of the solid lubricant material was identical whether a stainless steel shroud was present or not.

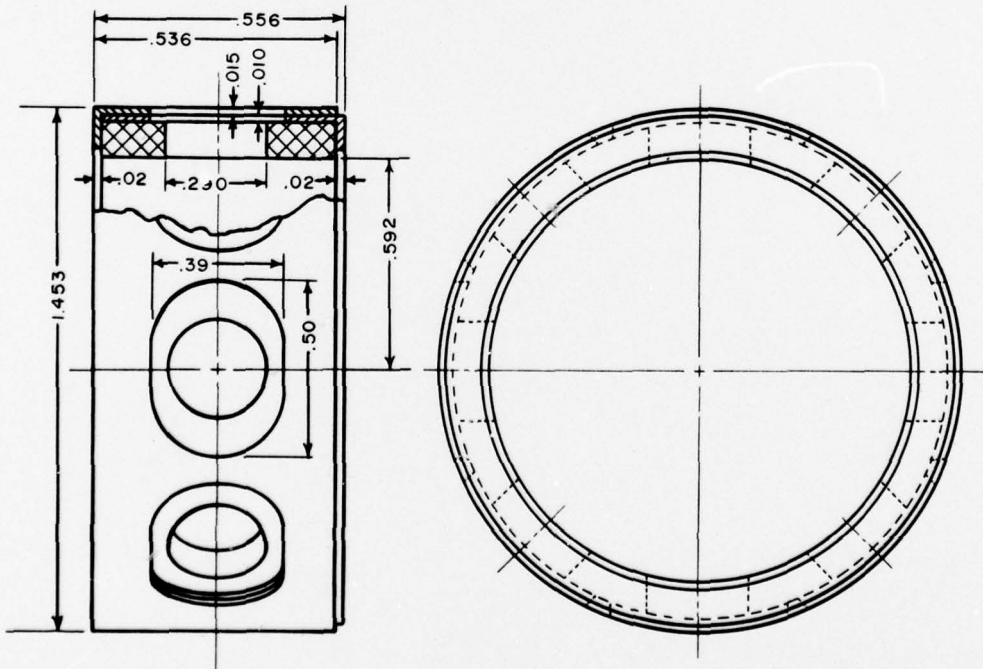

Figure 5. Size 204 Cage Design Using Double "L" Shroud

The materials being evaluated were composites which utilized a carbonized phenolic resin matrix containing graphite fibers for improving retainer strength and high-load performance; self-lubricating solids ( $\text{MoS}_2$  and tetrafluoroethylene), and a synergistic additive ( $\text{Sb}_2\text{O}_3$ ). Composition of the two materials in volume percent is given in Table II.

TABLE II

COMPOSITION OF SELF-LUBRICATING MATERIALS

Mat'l Code	Graphite Fiber Content - %	$\text{Sb}_2\text{O}_3$ % <sup>2</sup> <sub>3</sub>	$\text{MoS}_2$ % <sub>2</sub>	Tetrafluoroethylene %	Phenolic Resin Matrix - %
CID-101-(6X)	31.3	14.0	18.5	0	36.2
CID-111-3(6X)	30.7	13.7	18.1	2	35.5

SECTION III

TEST PROCEDURE

The test procedure used to conduct the solid lubricated bearing tests is described below:

1. Test Bearing Preparation:

The test bearings were prepared in the following manner prior to installation in the test rig:

- a. Initial degreasing in Stoddard solvent.
- b. Rinse in fresh methylene chloride.
- c. Final wash in ethyl alcohol.
- d. Composite cage installation and storage in dessicator until ready for test.

2. Test Start-up and Running Sequence

a. After the bearing is assembled in the test rig, rotation is initiated with full axial load and zero radial load.

b. Bearing speed is then increased to the desired value and the radial load, if any, is applied.

c. The bearing is then allowed to operate at a given speed and load condition until a stabilized bearing temperature is obtained. While waiting for the temperature to stabilize, intermediate values of torque and temperature were recorded every 15 minutes. Stabilized temperature operation was considered to have been reached when any two successive recordings of torque and temperature were identical. In general, stabilized temperatures were usually reached within 30 minutes after application of a new load or speed condition.

During the use of this test rig on a previous program (Ref. 3), it was found that oil used to cool and lubricate the rotary transformer (which is used in conjunction with the inner race temperature sensor) was leaking into the test chamber and contaminating the test bearing. Attempts were made

to correct the problem but none of them were entirely satisfactory. As a result, it was decided to eliminate the transformer and discontinue the inner race temperature measurement for this program.

SECTION IV  
DISCUSSION OF RESULTS

The objective of this program was to evaluate two self lubricating materials in a size 204 bearing and to determine the effect of speed and load on the bearing operating temperature, heat generation rate, and bearing running torque. These data would then be compared to that obtained for silver-mercury-teflon-molybdenum diselenide (AgHg) composites and gallium-indium-tungsten diselenide (WGI) composites previously evaluated in size 204 bearings (Ref. 3). A high degree of success has been achieved with the AgHg and WGI composites and thus these materials serve as a baseline to which new materials are compared.

The geometry of the solid lube cages was shown in Figure 5. The two materials were run both with and without the stainless steel shroud. Size and shape of the self lubricating material was as shown in Figure 5, regardless of the presence of the shroud.

The first bearing test of each material was run without the metal shrouds. Both of the unshrouded cages failed in a relatively short time. The first test was run on the CID-101 (6X) material. The cage failed after only 13 1/4 hours at 7500 RPM. Test #2 was run on the CID-111-3 (6X) material at 8000 RPM and failed in less than 5 hours. Failure of both cages was due to the cage material fracturing and breaking apart. Figure 6 is a photograph of the failed cage from the second test. Figures 7 and 8 are plots of bearing outer race temperature as a function of test time for the first two bearing tests. All test data is contained in the Appendix. Also included in the Appendix is the bearing heat generation rate calculated from the speed and torque data. (Ref. 4)

Because of the poor results obtained with the unshrouded cages, a series of tests was initiated using shrouded retainers. These retainers also exhibited relatively short lives, with two surviving less than 14 hours (CID-101 (6X)) and the third, CID-111-3 (6X) material, going only 46 hours. Figure 9 is a photograph of a typical shrouded cage after failure. Plots of bearing outer race temperatures for these three tests are shown in Figures 10, 11 and 12.

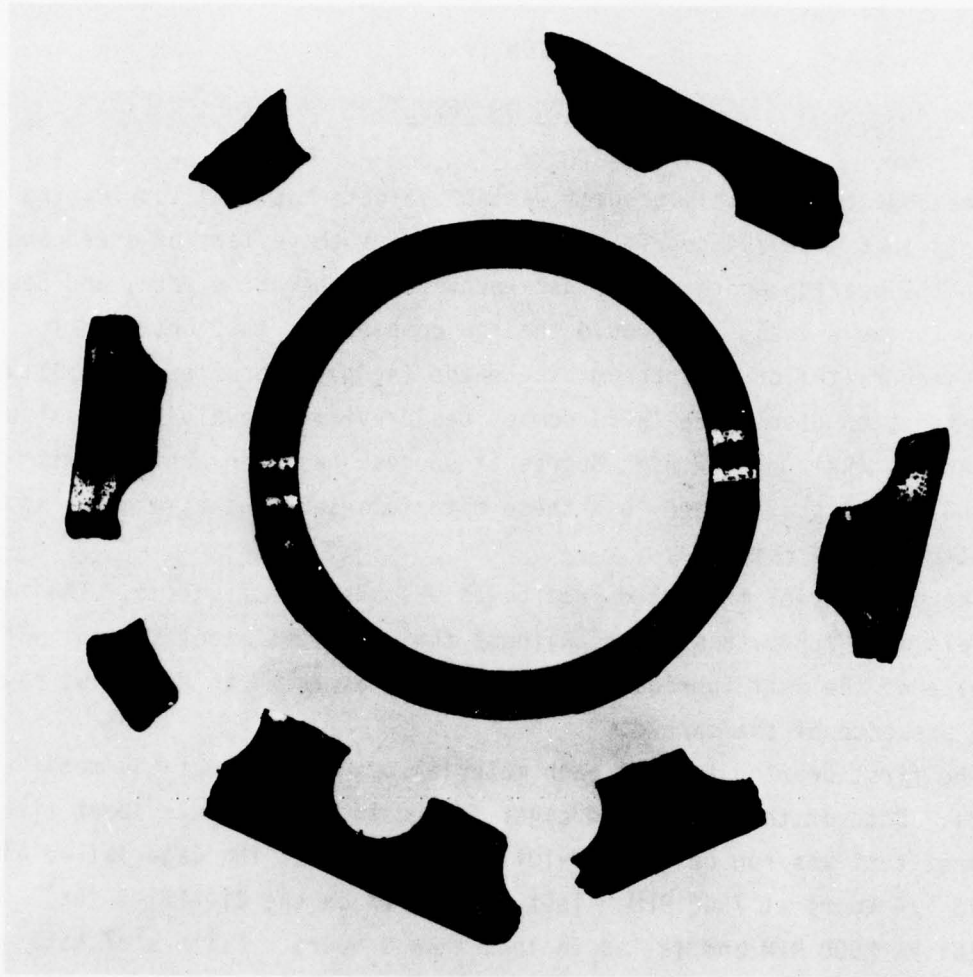

Figure 6. Failed Cage from Test No. 2

TEST #1

Unshrouded CID-101 (6x)  
65 pounds axial load  
7500 RPM

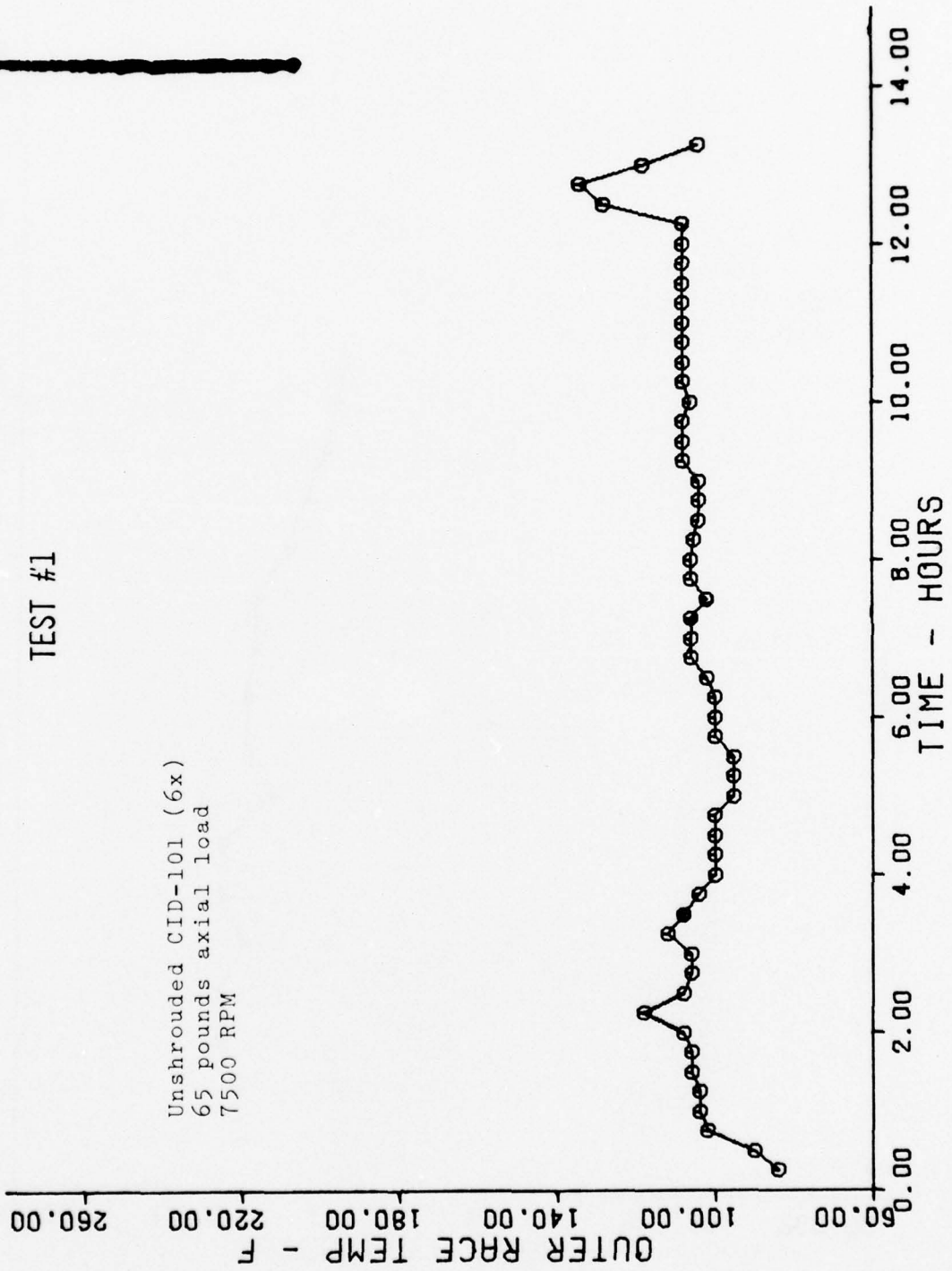

Figure 7 - Variation of Outer Race Temperature with Time

TEST # 2

Unshrouded CID-111-3 (6x)  
65 pounds axial load  
8,000 rpm

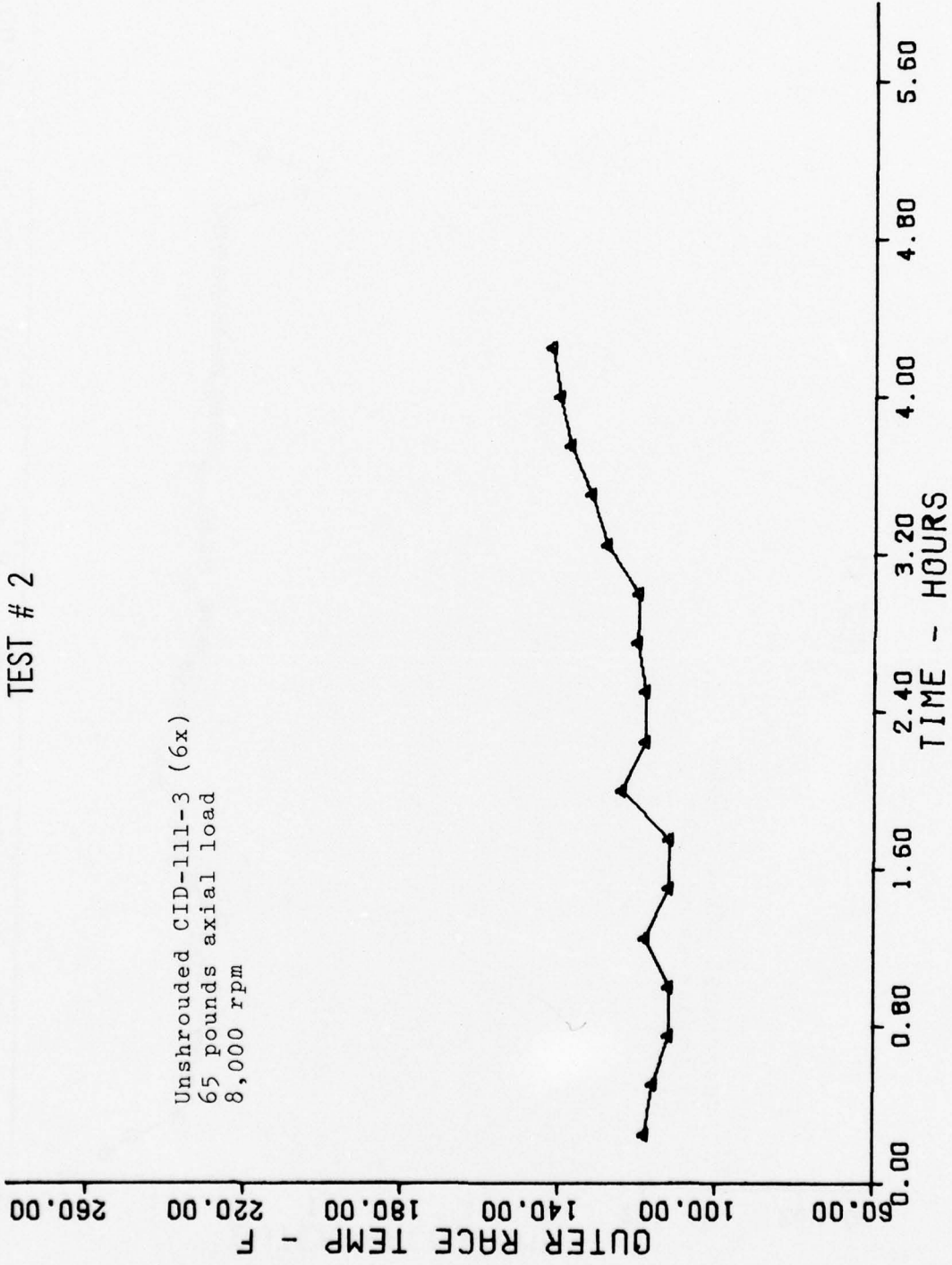

Figure 8 - Variation of Outer Race Temperature with Time

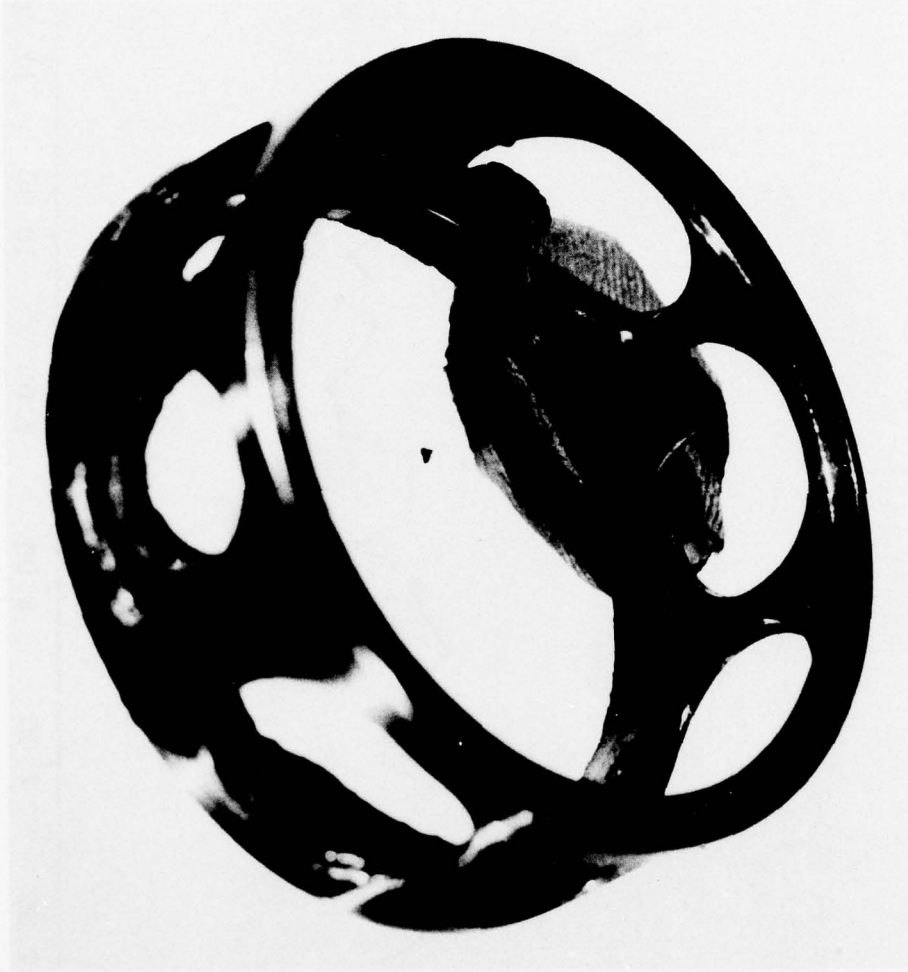

Figure 9. Photograph of a Typical Shrouded Retainer After Failure

TEST #3

Shrouded CID-101 (6x)  
81 pounds axial load  
10,000 rpm

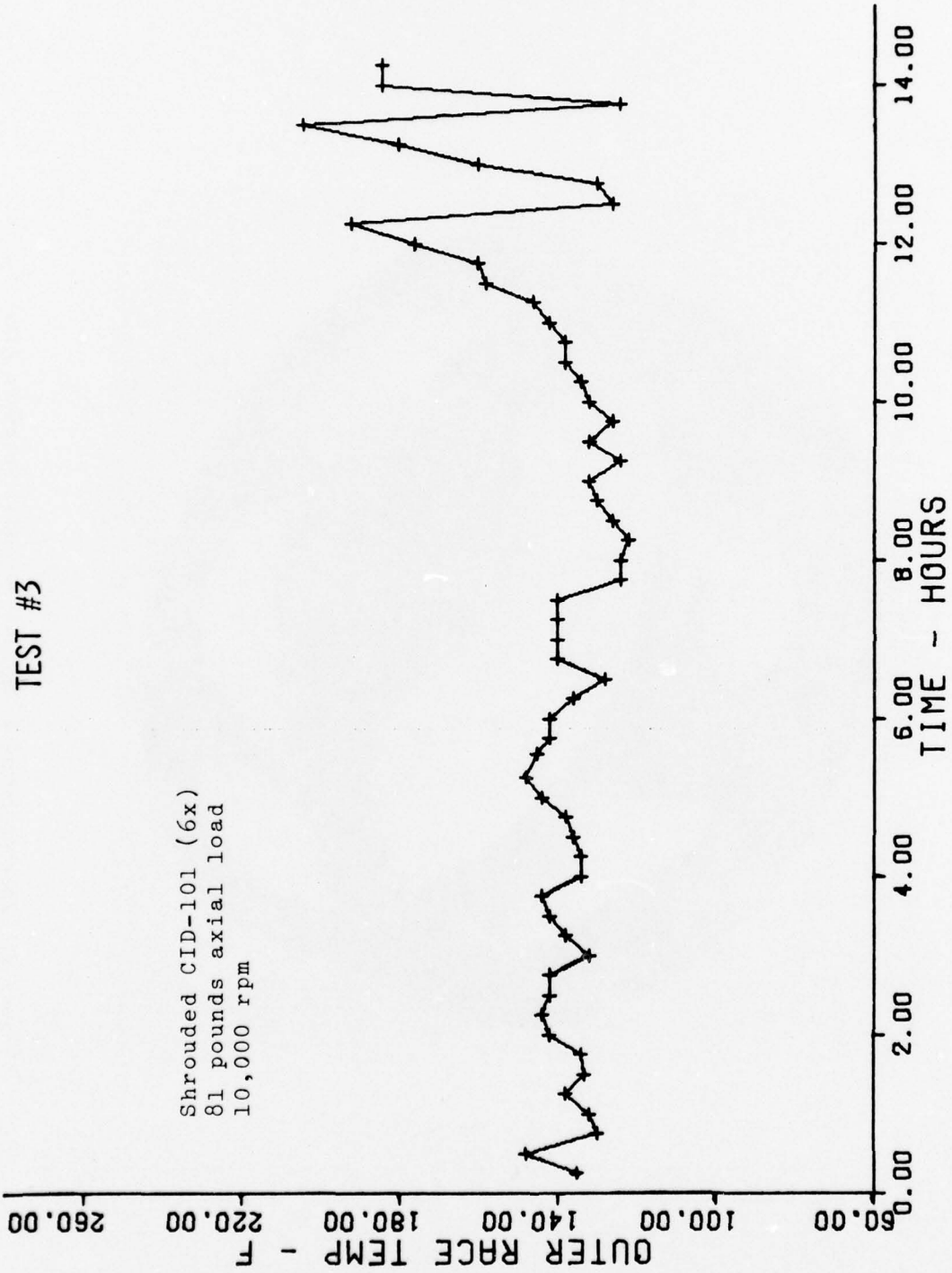

Figure 10 - Variation of Outer Race Temperature with Time

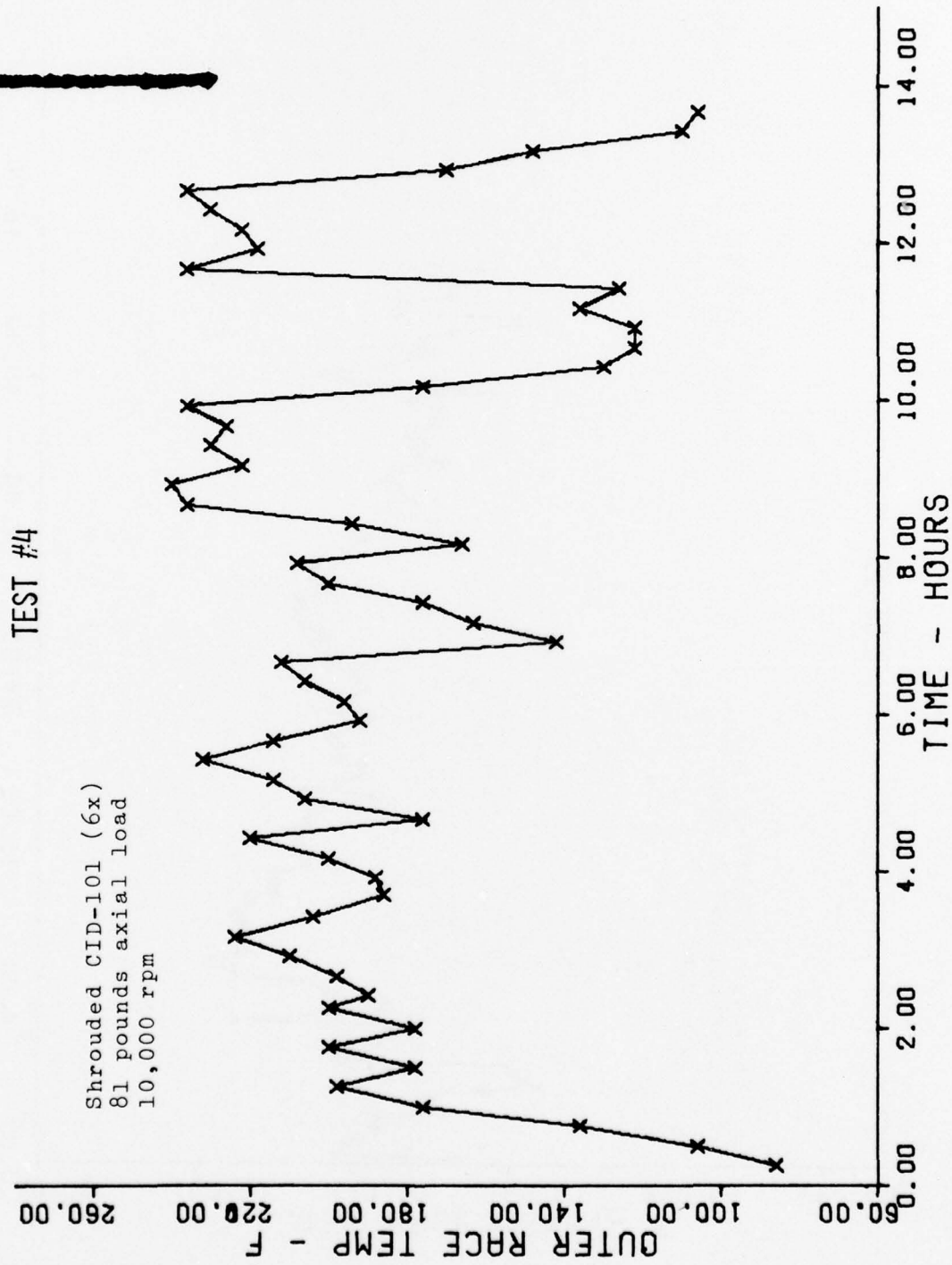

Figure 11 - Variation of Outer Race Temperature with Time

TEST #5

Shrouded CID-1111-3 (6x)  
81 pounds axial load  
7,500 rpm

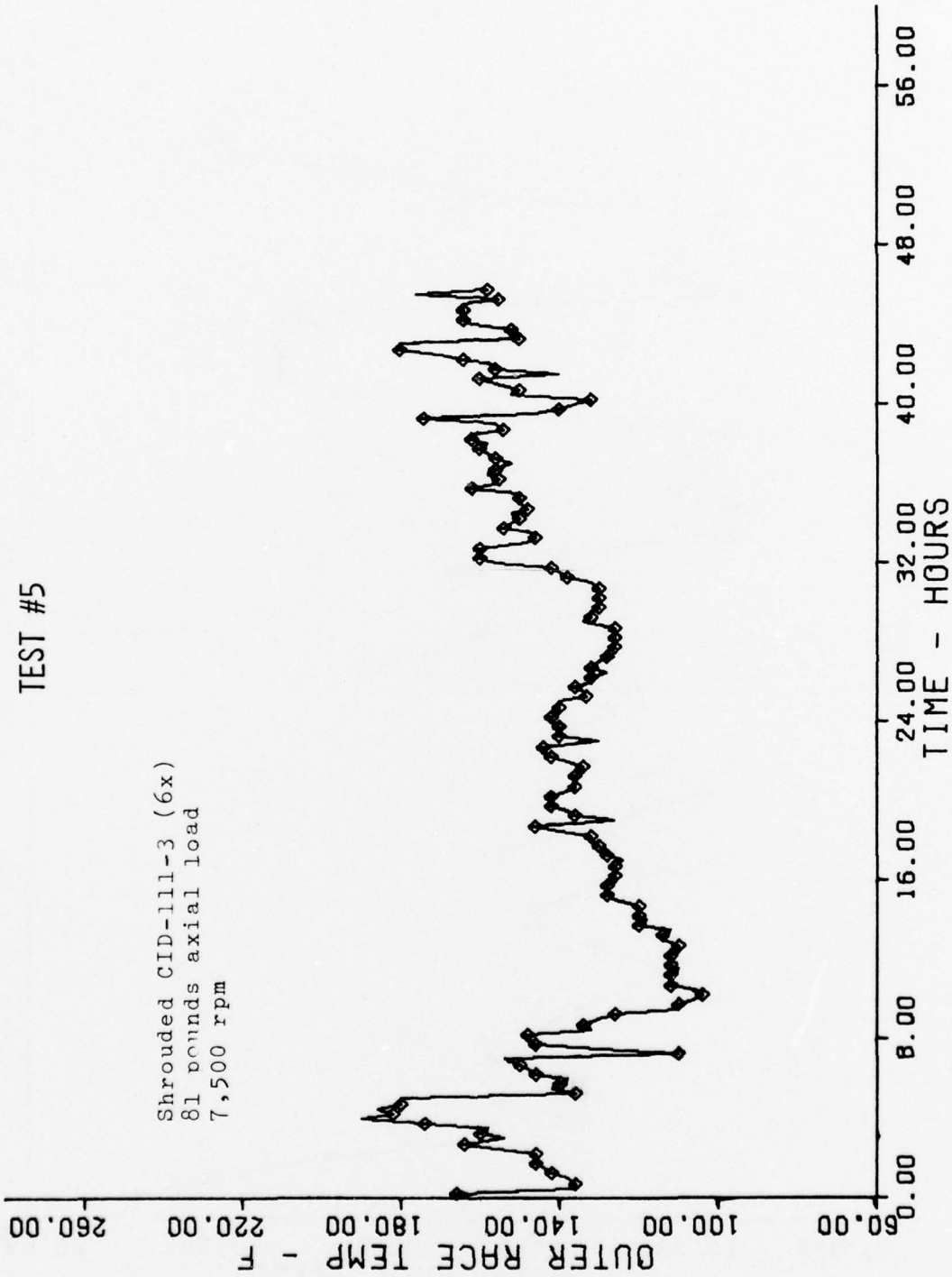

Figure 12 - Variation of Outer Race Temperature with Time

Comparison of the average bearing operating temperature and running torque for these two materials with that obtained using retainers of silver-mercury-teflon-molybdenum diselenide (AgHg) composites and the gallium-indium-tungsten diselenide (WGI) composites is shown in figures 13 and 14.

Both the operating temperatures and running torques for the carbonized phenolic composite materials are significantly higher than that obtained for the AgHg or WGI composites. In addition the current life capability for the AgHg or WGI retainers operating at or below 10,000 RPM is between 2,000 and 7,000 hours at room temperature conditions. Since the life of the carbonized phenolic composite cages was less than 50 hours at 10,000 RPM, running at room temperature conditions, no further testing of these carbonized phenolic resin materials is anticipated.

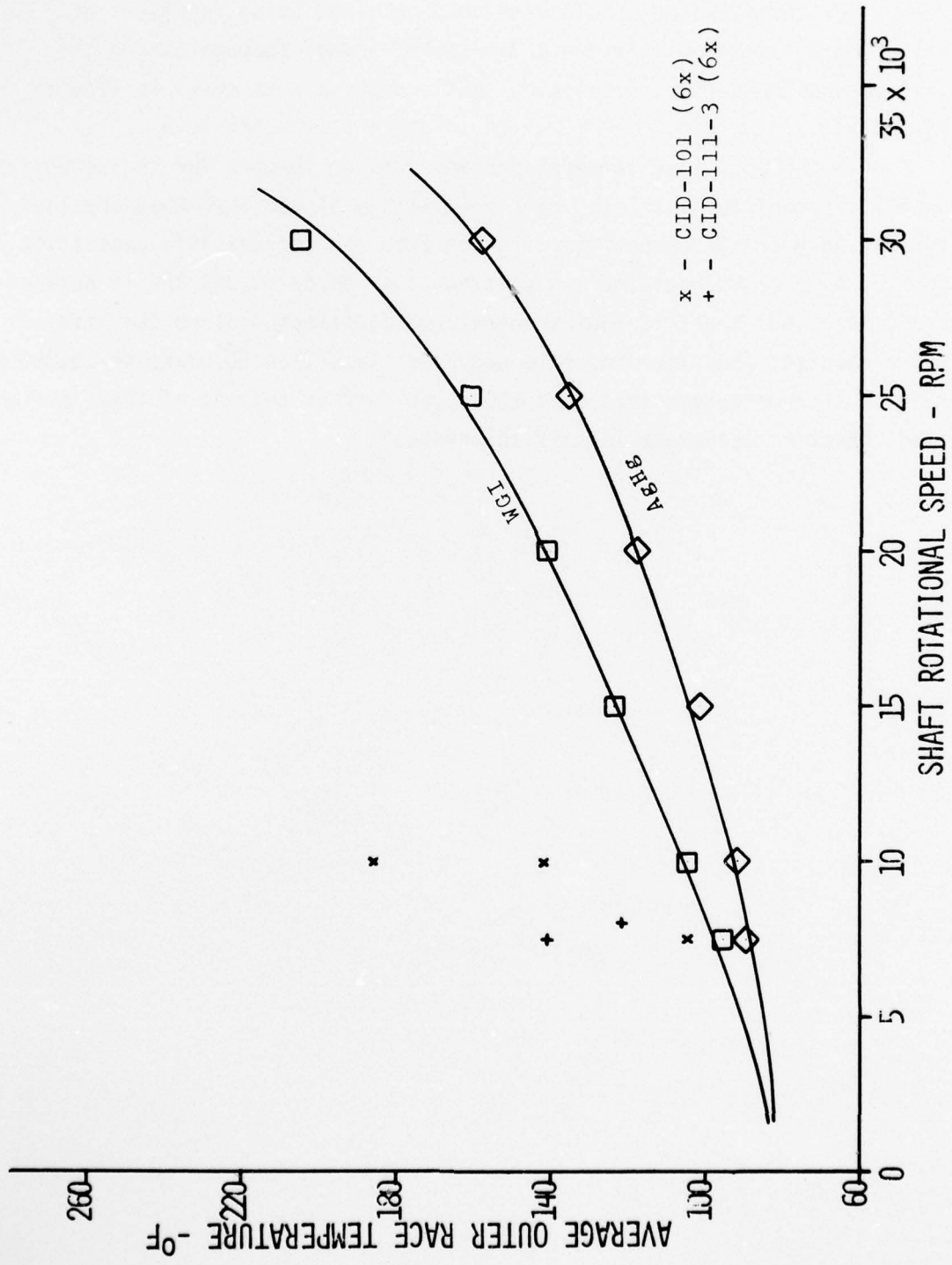

Figure 13 - Variation of Bearing Outer Race Temperature with Shaft Rotational Speed for Bearings with AgHg, WGI, and CPR Composite Cages

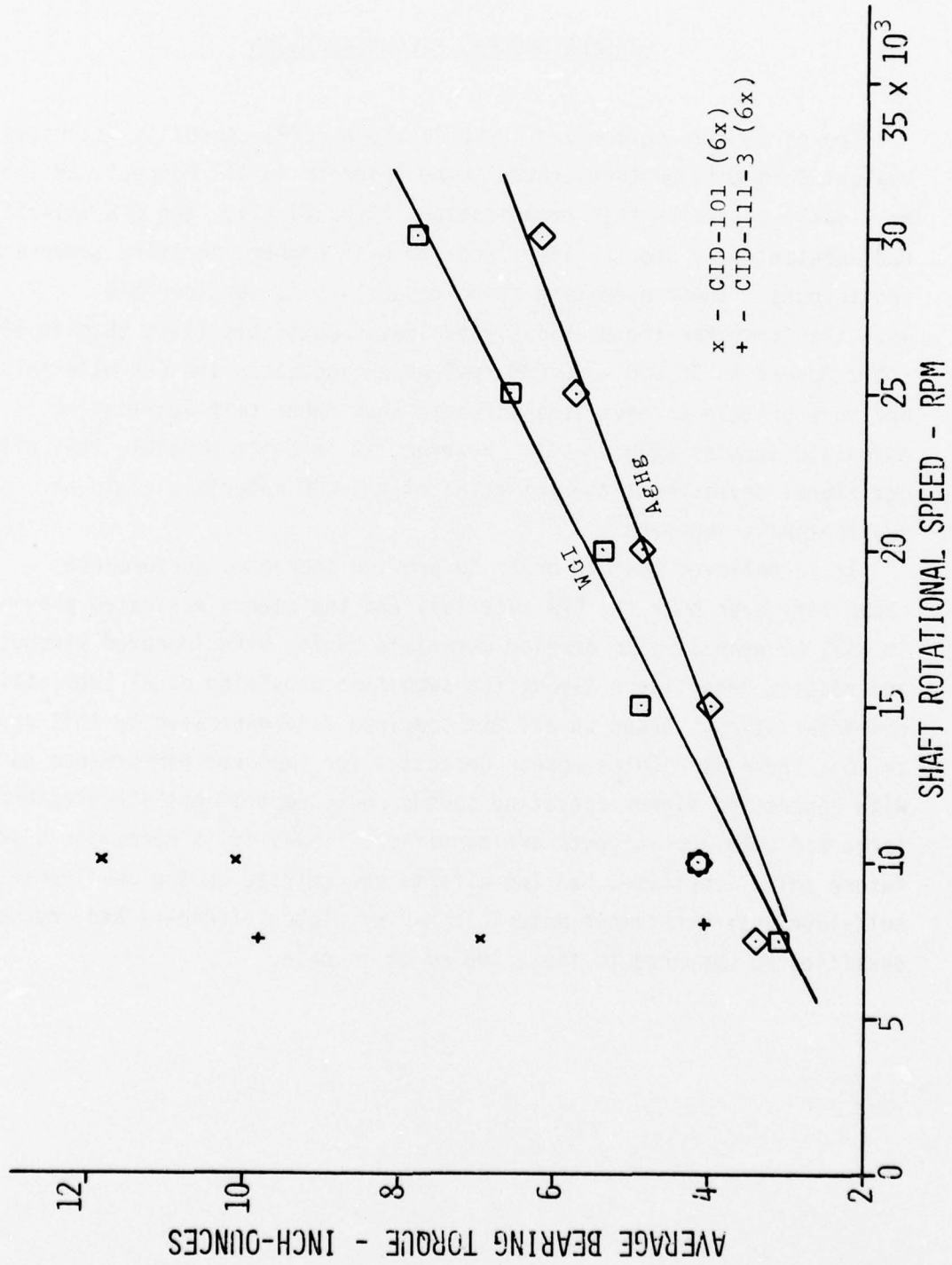

Figure 14 - Variation of Average Bearing Torque with Shaft Rotational Speed for Bearings with AGHG, WGI, and CPR Composite Cages

## SECTION V

### CONCLUSIONS AND RECOMMENDATIONS

The particular carbonized phenolic resin (CPR) composite materials evaluated in this program proved to be inferior in all respects to those previously tested by this organization. Specifically, the CPR materials had substantially shorter lives and ran with higher operating temperatures and torques. Their operating speed capability is considerably less than that for the previously evaluated materials (less than 10,000 rpm compared to 20,000 - 30,000 rpm) which indicates the CPR materials are more brittle or have less strength than other self lubricating materials such as AgHg or WGI. However, it is quite possible that with additional development the potential of the CPR materials could be substantially improved.

It is believed that in order to provide increased performance capability over both the CPR materials and the others evaluated previously, it will be necessary to develop materials having both improved strength and reduced densities while at the same time providing equal lubricating characteristics. Based on all the previous data generated by this organization, these attributes appear necessary for improved performance especially with respect to higher operating speeds where centrifugal stresses become large and unbalance effects are magnified. Thus, it is recommended that future solid lubricated bearing efforts concentrate on the development of self-lubricating retainer materials having higher strengths and reduced densities as compared to those looked at to date.

## REFERENCES

1. Melvin T. Lavik, Vern Hopkins, Development of Self-Lubricating Composites Utilizing Carbonized Phenolic Matrix, AFML-TR-75-175, Part I, Midwest Research Institute, Kansas City, MO, December 1975.
2. Melvin T. Lavik, Vern Hopkins, Development of Self-Lubricating Composites Utilizing Carbonized Phenolic Matrix, Part II, A Summary Report, AFML-TR-75-175, Part II, Midwest Research Institute, Kansas City, Missouri, April 1976.
3. R. D. Dayton and M. A. Sheets, Evaluation of Grooved Solid Lubricated Bearings, Air Force Aero Propulsion Laboratory, Wright-Patterson Air Force Base, Ohio 45433, AFAPL-TR-75-76, February 1976.
4. Tedric A. Harris, Rolling Bearing Analysis, John Wiley & Sons, Inc. New York, 1966.

APPENDIX

TEST DATA

TEST #1 SIZE 204 BEARING WITH SELF-LUBRICATING CID-101 UNSHROUDED CPR RETAINER

TEST TIME HOURS	OUTER RACE TEMP - F	TORQUE IN.OZ.	HEAT GEN BTU/HOUR	AXIAL LOAD-LBS.	RADIAL LOAD-LBS	SPEED RPM
.25	84.	5.	1394.	66.	0.	7500.
.50	90.	3.	1045.	66.	0.	7500.
.75	102.	1.	348.	66.	0.	7500.
1.00	104.	0.	0.	66.	0.	7500.
1.25	104.	1.	348.	66.	0.	7500.
1.50	106.	1.	348.	66.	0.	7500.
1.75	106.	1.	348.	66.	0.	7500.
2.00	108.	14.	4181.	66.	0.	7500.
2.25	118.	14.	4181.	66.	0.	7500.
2.50	108.	14.	4181.	66.	0.	7500.
2.75	106.	14.	4181.	66.	0.	7500.
3.00	106.	14.	4181.	66.	0.	7500.
3.25	112.	9.	2788.	66.	0.	7500.
3.50	108.	9.	2788.	66.	0.	7500.
3.75	104.	9.	2788.	66.	0.	7500.
4.00	100.	9.	2788.	66.	0.	7500.
4.25	100.	9.	2788.	66.	0.	7500.
4.50	100.	9.	2788.	66.	0.	7500.
4.75	100.	9.	2788.	66.	0.	7500.
5.00	95.	9.	2788.	66.	0.	7500.
5.25	95.	10.	3136.	66.	0.	7500.
5.50	95.	10.	3136.	66.	0.	7500.
5.75	100.	12.	3485.	66.	0.	7500.
6.00	100.	12.	3485.	66.	0.	7500.
6.25	100.	12.	3485.	66.	0.	7500.
6.50	102.	2.	697.	66.	0.	7500.
6.75	106.	2.	697.	66.	0.	7500.
7.00	106.	5.	1394.	66.	0.	7500.
7.25	106.	5.	1394.	66.	0.	7500.
7.50	102.	2.	697.	66.	0.	7500.
7.75	106.	2.	697.	66.	0.	7500.

TEST #1 SIZE 204 REAPING WITH SELF-LUBRICATING CID-101 UNSHROUDED CPR RETAINER

TEST TIME HOURS	OUTER RACE TEMP - F	TORQUE IN.OZ.	HEAT GEN BTU/HOUR	AXIAL LOAD-LBS.	RADIAL LOAD-LBS	SPEED RPM
8.00	106.	3.	1045.	66.	0.	7500.
8.25	105.	3.	1045.	66.	0.	7500.
8.50	104.	3.	1045.	66.	0.	7500.
8.75	104.	3.	1045.	66.	0.	7500.
9.00	104.	3.	1045.	66.	0.	7500.
9.25	108.	2.	697.	66.	0.	7500.
9.50	108.	2.	697.	66.	0.	7500.
9.75	108.	2.	697.	66.	0.	7500.
10.00	106.	2.	697.	66.	0.	7500.
10.25	108.	2.	697.	66.	0.	7500.
10.50	108.	2.	697.	66.	0.	7500.
10.75	108.	2.	697.	66.	0.	7500.
11.00	108.	2.	697.	66.	0.	7500.
11.25	108.	2.	697.	66.	0.	7500.
11.50	108.	2.	697.	66.	0.	7500.
11.75	108.	2.	697.	66.	0.	7500.
12.00	108.	2.	697.	66.	0.	7500.
12.25	108.	2.	697.	66.	0.	7500.
12.50	128.	5.	1858.	66.	0.	10000.
12.75	134.	5.	1858.	66.	0.	10000.
13.00	118.	5.	1858.	66.	0.	10000.
13.25	104.	78.	31593.	66.	0.	10000.

AVERAGE BEARING OUTER RACE TEMPERATURE = 105.43 F

AVERAGE BEARING TORQUE = 6.94 OUNCE-INCHES

AVERAGE HEAT GENERATION RATE = 2279. BTU/HOUR

TEST #2 SIZE 204 BEARING WITH SELF-LUBRICATING CID-111 UNSHROUDED CPR RETAINER

TEST TIME HOURS	OUTER RACE TEMP - F	TORQUE IN.OZ.	HEAT GEN BTU/HOUR	AXIAL LOAD-LBS.	RADIAL LOAD-LBS	SPEED RPM
.25	118.	2.	697.	66.	0.	7500.
.50	116.	0.	0.	66.	0.	7500.
.75	112.	2.	697.	66.	0.	7500.
1.00	112.	2.	743.	66.	0.	8000.
1.25	118.	2.	743.	66.	0.	8000.
1.50	112.	2.	743.	66.	0.	8000.
1.75	112.	2.	743.	66.	0.	8000.
2.00	124.	2.	743.	66.	0.	8000.
2.25	118.	5.	1487.	66.	0.	8000.
2.50	118.	5.	1487.	66.	0.	8000.
2.75	120.	5.	1487.	66.	0.	8000.
3.00	120.	5.	1487.	66.	0.	8000.
3.25	128.	7.	2230.	66.	0.	8000.
3.50	132.	7.	2230.	66.	0.	8000.
3.75	137.	7.	2230.	66.	0.	8000.
4.00	140.	7.	2230.	66.	0.	8000.
4.25	142.	7.	2230.	66.	0.	8000.

AVERAGE BEARING OUTER RACE TEMPERATURE = 122.29 F

AVERAGE BEARING TORQUE = 4.06 OUNCE-INCHES

AVERAGE HEAT GENERATION RATE = 1306. BTU/HOUR

TEST #3 SIZE 204 BEARING WITH SELF LUBRICATING CID-101 SHROUDED CPR RETAINER

TEST TIME HOURS	OUTER RACE TEMP - F	TORQUE IN.OZ.	HEAT GEN BTU/HOUR	AXIAL LOAD-LBS.	RADIAL LOAD-LBS	SPEED RPM
.25	135.	16.	6504.	81.	0.	10000.
.50	148.	16.	6504.	81.	0.	10000.
.75	130.	16.	6504.	81.	0.	10000.
1.00	132.	16.	6504.	81.	0.	10000.
1.25	138.	18.	7434.	81.	0.	10000.
1.50	133.	18.	7434.	81.	0.	10000.
1.75	134.	18.	7434.	81.	0.	10000.
2.00	142.	18.	7434.	81.	0.	10000.
2.25	144.	21.	8363.	81.	0.	10000.
2.50	142.	21.	8363.	81.	0.	10000.
2.75	142.	21.	8363.	81.	0.	10000.
3.00	132.	5.	1858.	81.	0.	10000.
3.25	138.	2.	929.	81.	0.	10000.
3.50	142.	7.	2788.	81.	0.	10000.
3.75	144.	7.	2788.	81.	0.	10000.
4.00	134.	9.	3717.	81.	0.	10000.
4.25	134.	9.	3717.	81.	0.	10000.
4.50	136.	9.	3717.	81.	0.	10000.
4.75	138.	9.	3717.	81.	0.	10000.
5.00	144.	12.	4646.	81.	0.	10000.
5.25	148.	9.	3717.	81.	0.	10000.
5.55	145.	12.	4646.	81.	0.	10000.
5.75	142.	9.	3717.	81.	0.	10000.
6.00	142.	9.	3717.	81.	0.	10000.
6.25	136.	9.	3717.	81.	0.	10000.
6.50	128.	7.	2788.	81.	0.	10000.
6.75	140.	12.	4646.	81.	0.	10000.
7.00	140.	12.	4646.	81.	0.	10000.
7.25	140.	5.	1858.	81.	0.	10000.
7.50	140.	5.	1858.	81.	0.	10000.
7.75	124.	2.	929.	81.	0.	10000.

TEST #3 SIZE 204 BEARING WITH SELF LUBRICATING CID-101 SHROUDED CPR RETAINER

TEST TIME HOURS	OUTER RACE TEMP - F	TORQUE IN.OZ.	HEAT GEN BTU/HOUR	AXIAL LOAD-LBS.	RADIAL LOAD-LBS	SPEED RPM
8.00	124.	2.	929.	81.	0.	10000.
8.25	122.	2.	929.	81.	0.	10000.
8.50	126.	5.	1858.	81.	0.	10000.
8.75	130.	5.	1858.	81.	0.	10000.
9.00	132.	5.	1858.	81.	0.	10000.
9.25	124.	5.	1858.	81.	0.	10000.
9.50	132.	5.	1858.	81.	0.	10000.
9.75	126.	5.	1858.	81.	0.	10000.
10.00	132.	5.	1858.	81.	0.	10000.
10.25	134.	5.	1858.	81.	0.	10000.
10.50	138.	2.	929.	81.	0.	10000.
10.75	138.	5.	1858.	81.	0.	10000.
11.00	142.	5.	1858.	81.	0.	10000.
11.25	146.	5.	1858.	81.	0.	10000.
11.50	158.	9.	3717.	81.	0.	10000.
11.75	160.	9.	3717.	81.	0.	10000.
12.00	176.	9.	3717.	81.	0.	10000.
12.25	192.	14.	5575.	81.	0.	10000.
12.50	126.	5.	1858.	81.	0.	10000.
12.75	130.	14.	5575.	81.	0.	10000.
13.00	160.	16.	6504.	81.	0.	10000.
13.25	180.	14.	5575.	81.	0.	10000.
13.50	204.	28.	11150.	81.	0.	10000.
13.75	124.	14.	5575.	81.	0.	10000.
14.00	194.	14.	5575.	81.	0.	10000.
14.25	184.	14.	5575.	81.	0.	10000.

AVERAGE BEARING OUTER RACE TEMPERATURE = 142.30 F

AVERAGE BEARING TORQUE = 10.09 OUNCE-INCHES

AVERAGE HEAT GENERATION RATE = 4075. BTU/HOUR

TEST #4 SIZE 204 BEARING WITH SELF LUBRICATING CID-101 SHROUDED CPR RETAINER

TEST TIME HOURS	OUTER RACE TEMP - F	TORQUE IN.OZ.	HEAT GEN BTU/HOUR	AXIAL LOAD-LBS.	RADIAL LOAD-LBS	SPEED RPM
.25	86.	1.	465.	81.	0.	10000.
.50	106.	5.	1858.	81.	0.	10000.
.75	136.	7.	2788.	81.	0.	10000.
1.00	176.	12.	4646.	81.	0.	10000.
1.25	198.	14.	5575.	81.	0.	10000.
1.50	178.	9.	3717.	81.	0.	10000.
1.75	200.	12.	4646.	81.	0.	10000.
2.00	178.	5.	1858.	81.	0.	10000.
2.25	200.	12.	4646.	81.	0.	10000.
2.42	190.	12.	4646.	81.	0.	10000.
2.67	198.	14.	5575.	81.	0.	10000.
2.92	210.	14.	5575.	81.	0.	10000.
3.17	224.	16.	6504.	81.	0.	10000.
3.42	204.	9.	3717.	81.	0.	10000.
3.70	186.	9.	3717.	81.	0.	10000.
3.92	188.	9.	3717.	81.	0.	10000.
4.17	200.	9.	3717.	81.	0.	10000.
4.42	220.	14.	5575.	81.	0.	10000.
4.67	176.	12.	4646.	81.	0.	10000.
4.92	206.	14.	5575.	81.	0.	10000.
5.17	214.	14.	5575.	81.	0.	10000.
5.42	232.	16.	6504.	81.	0.	10000.
5.67	214.	9.	3717.	81.	0.	10000.
5.92	192.	9.	3717.	81.	0.	10000.
6.17	196.	14.	5575.	81.	0.	10000.
6.42	206.	14.	5575.	81.	0.	10000.
6.67	212.	18.	7434.	81.	0.	10000.
6.92	142.	9.	3717.	81.	0.	10000.
7.17	163.	15.	6040.	81.	0.	10000.
7.42	176.	18.	7434.	81.	0.	10000.
7.67	200.	14.	5575.	81.	0.	10000.

TEST #4 SIZE 204 BEARING WITH SELF LUBRICATING CID-101 SHROUDED CPR RETAINER

TEST TIME HOURS	OUTER RACE TEMP - F	TORQUE IN.OZ.	HEAT GEN BTU/HOUR	AXIAL LOAD-LBS.	RADIAL LOAD-LBS	SPEED RPM
7.92	208.	18.	7434.	81.	0.	10000.
8.17	166.	16.	6504.	81.	0.	10000.
8.42	194.	18.	7434.	81.	0.	10000.
8.67	236.	18.	7434.	81.	0.	10000.
8.92	240.	21.	8363.	81.	0.	10000.
9.17	222.	18.	7434.	81.	0.	10000.
9.42	230.	21.	8363.	81.	0.	10000.
9.67	226.	18.	7434.	81.	0.	10000.
9.92	236.	19.	7434.	81.	0.	10000.
10.17	176.	5.	1858.	81.	0.	10000.
10.42	130.	2.	929.	81.	0.	10000.
10.67	122.	5.	1858.	81.	0.	10000.
10.92	122.	7.	2788.	81.	0.	10000.
11.17	136.	5.	1858.	81.	0.	10000.
11.42	126.	14.	5575.	81.	0.	10000.
11.67	236.	18.	7434.	81.	0.	10000.
11.92	218.	16.	6504.	81.	0.	10000.
12.17	222.	16.	6504.	81.	0.	10000.
12.42	230.	16.	6504.	81.	0.	10000.
12.67	236.	16.	6504.	81.	0.	10000.
12.92	170.	7.	2788.	81.	0.	10000.
13.17	148.	0.	0.	81.	0.	10000.
13.42	110.	0.	0.	81.	0.	10000.
13.67	106.	0.	0.	81.	0.	10000.

AVERAGE BEARING OUTER RACE TEMPERATURE = 186.42 F

AVERAGE BEARING TORQUE = 11.83 OUNCE-INCHES

AVERAGE HEAT GENERATION RATE = 4781.8 BTU/HOUR

TEST #5 SIZE 204 BEARING WITH SELF LUBRICATING CID-111 SHROUDED CPR RETAINER

TEST TIME HOURS	OUTER RACE TEMP - F	TORQUE IN.OZ.	HEAT GEN BTU/HOUR	AXIAL LOAD-LBS.	RADIAL LOAD-LBS	SPEED RPM
.25	166.	2.	697.	81.	0.	7500.
.50	136.	5.	1394.	81.	0.	7500.
.75	136.	7.	2091.	81.	0.	7500.
1.00	138.	5.	1394.	81.	0.	7500.
1.25	142.	7.	2091.	81.	0.	7500.
1.50	144.	7.	2091.	81.	0.	7500.
1.75	146.	7.	2091.	81.	0.	7500.
2.00	146.	7.	2091.	81.	0.	7500.
2.25	146.	7.	2091.	81.	0.	7500.
2.50	156.	12.	3485.	81.	0.	7500.
2.75	164.	7.	2091.	81.	0.	7500.
3.00	154.	7.	2091.	81.	0.	7500.
3.25	160.	7.	2091.	81.	0.	7500.
3.50	158.	10.	3136.	81.	0.	7500.
3.75	174.	12.	3485.	81.	0.	7500.
4.00	190.	12.	3485.	81.	0.	7500.
4.25	182.	14.	4181.	81.	0.	7500.
4.50	186.	14.	4181.	81.	0.	7500.
4.75	180.	12.	3485.	81.	0.	7500.
5.00	180.	12.	3485.	81.	0.	7500.
5.25	136.	7.	2091.	81.	0.	7500.
5.50	142.	7.	2091.	81.	0.	7500.
5.75	140.	7.	2091.	81.	0.	7500.
6.00	138.	9.	2788.	81.	0.	7500.
6.25	146.	9.	2788.	81.	0.	7500.
6.50	148.	9.	2788.	81.	0.	7500.
6.75	150.	9.	2788.	81.	0.	7500.
7.00	154.	12.	3485.	81.	0.	7500.
7.25	110.	7.	2091.	81.	0.	7500.
7.50	130.	7.	2091.	81.	0.	7500.
7.75	146.	7.	2091.	81.	0.	7500.

TEST #5 SIZE 204 BEARING WITH SELF LUBRICATING CID-111 SHROUDED CPR RETAINER

TEST TIME HOURS	OUTER RACE TEMP - F	TORQUE IN.OZ.	HEAT GEN BTU/HOUR	AXIAL LOAD-LBS.	RADIAL LOAD-LBS	SPEED RPM
8.00	148.	7.	2091.	81.	0.	7500.
8.25	148.	7.	2091.	81.	0.	7500.
8.50	132.	7.	2091.	81.	0.	7500.
8.75	134.	7.	2091.	81.	0.	7500.
9.00	130.	5.	1394.	81.	0.	7500.
9.25	126.	5.	1394.	81.	0.	7500.
9.50	110.	5.	1394.	81.	0.	7500.
9.75	110.	5.	1394.	81.	0.	7500.
10.00	106.	2.	697.	81.	0.	7500.
10.25	104.	2.	697.	81.	0.	7500.
10.50	106.	5.	1394.	81.	0.	7500.
10.75	112.	5.	1394.	81.	0.	7500.
11.00	112.	2.	697.	81.	0.	7500.
11.25	112.	2.	697.	81.	0.	7500.
11.50	110.	2.	697.	81.	0.	7500.
11.75	112.	5.	1394.	81.	0.	7500.
12.00	112.	5.	1394.	81.	0.	7500.
12.25	112.	5.	1394.	81.	0.	7500.
12.50	110.	5.	1394.	81.	0.	7500.
12.75	110.	5.	1394.	81.	0.	7500.
13.00	114.	7.	2091.	81.	0.	7500.
13.25	114.	9.	2788.	81.	0.	7500.
13.50	112.	7.	2091.	81.	0.	7500.
13.75	120.	9.	2788.	81.	0.	7500.
14.00	118.	9.	2788.	91.	0.	7500.
14.25	120.	7.	2091.	81.	0.	7500.
14.50	120.	7.	2091.	81.	0.	7500.
14.75	120.	7.	2091.	81.	0.	7500.
15.00	126.	7.	2091.	81.	0.	7500.
15.25	128.	7.	2091.	81.	0.	7500.
15.50	128.	7.	2091.	81.	0.	7500.

TEST #5 SIZE 204 BEARING WITH SELF LUBRICATING CID-111 SHROUDED CPR RETAINER

TEST TIME HOURS	OUTER RACE TEMP - F	TORQUE IN.OZ.	HEAT GEN BTU/HOUR	AXIAL LOAD-LBS.	RADIAL LOAD-LBS	SPEED RPM
15.75	128.	7.	2091.	81.	0.	7500.
16.00	126.	7.	2091.	81.	0.	7500.
16.25	126.	7.	2091.	81.	0.	7500.
16.50	126.	7.	2091.	81.	0.	7500.
16.75	126.	7.	2091.	81.	0.	7500.
17.00	124.	7.	2091.	81.	0.	7500.
17.25	128.	7.	2091.	81.	0.	7500.
17.50	128.	7.	2091.	81.	0.	7500.
17.75	130.	7.	2091.	81.	0.	7500.
18.00	132.	9.	2788.	81.	0.	7500.
18.25	132.	9.	2788.	81.	0.	7500.
18.50	140.	12.	3485.	81.	0.	7500.
19.75	146.	9.	2788.	81.	0.	7500.
19.00	126.	16.	4878.	81.	0.	7500.
19.25	136.	16.	4878.	81.	0.	7500.
19.50	138.	14.	4181.	81.	0.	7500.
19.75	142.	16.	4878.	81.	0.	7500.
20.00	142.	14.	4181.	81.	0.	7500.
20.25	142.	16.	4878.	81.	0.	7500.
20.50	138.	16.	4878.	81.	0.	7500.
20.75	136.	14.	4181.	81.	0.	7500.
21.00	136.	14.	4181.	81.	0.	7500.
21.25	136.	16.	4878.	81.	0.	7500.
21.50	134.	16.	4878.	81.	0.	7500.
21.75	134.	16.	4878.	81.	0.	7500.
22.00	138.	7.	2091.	81.	0.	7500.
22.25	142.	7.	2091.	81.	0.	7500.
22.50	144.	5.	1394.	81.	0.	7500.
22.75	144.	5.	1394.	81.	0.	7500.
23.00	130.	7.	2091.	81.	0.	7500.
23.25	140.	7.	2091.	81.	0.	7500.

TEST #5 SIZE 204 BEARING WITH SELF LUBRICATING CID-111 SHROUDED CPR RETAINER

TEST TIME HOURS	OUTER RACE TEMP - F	TORQUE IN.OZ.	HEAT GEN BTU/HOUR	AXIAL LOAD-LBS.	RADIAL LOAD-LBS	SPEED RPM
23.50	140.	7.	2091.	81.	0.	7500.
23.75	140.	7.	2091.	81.	0.	7500.
24.00	142.	7.	2091.	81.	0.	7500.
24.25	142.	7.	2091.	81.	0.	7500.
24.50	140.	5.	1394.	81.	0.	7500.
24.75	140.	5.	1394.	81.	0.	7500.
25.00	140.	5.	1394.	81.	0.	7500.
25.25	133.	7.	2091.	81.	0.	7500.
25.50	134.	7.	2091.	81.	0.	7500.
25.75	136.	7.	2091.	81.	0.	7500.
26.00	132.	7.	2091.	81.	0.	7500.
26.25	132.	7.	2091.	81.	0.	7500.
26.50	128.	5.	1394.	81.	0.	7500.
26.75	132.	5.	1394.	81.	0.	7500.
27.00	130.	5.	1394.	81.	0.	7500.
27.25	128.	5.	1394.	81.	0.	7500.
27.50	128.	5.	1394.	81.	0.	7500.
27.75	126.	5.	1394.	81.	0.	7500.
28.00	126.	5.	1394.	81.	0.	7500.
28.25	126.	5.	1394.	81.	0.	7500.
28.50	126.	5.	1394.	81.	0.	7500.
28.75	126.	5.	1394.	81.	0.	7500.
29.00	134.	12.	3485.	81.	0.	7500.
29.25	132.	12.	3485.	81.	0.	7500.
29.50	132.	12.	3485.	81.	0.	7500.
29.75	130.	12.	3485.	81.	0.	7500.
30.00	130.	12.	3485.	81.	0.	7500.
30.25	130.	12.	3485.	81.	0.	7500.
30.50	130.	12.	3485.	81.	0.	7500.
30.75	130.	12.	3485.	81.	0.	7500.
31.00	132.	12.	3485.	81.	0.	7500.

TEST #5 SIZE 204 BEARING WITH SELF LUBRICATING CID-111 SHROUDED CPR RETAINER

TEST TIME HOURS	OUTER RACE TEMP - F	TORQUE IN.OZ.	HEAT GEN BTU/HOUR	AXIAL LOAD-LBS.	RADIAL LOAD-LBS	SPEED RPM
31.25	138.	14.	4181.	81.	0.	7500.
31.50	140.	14.	4181.	81.	0.	7500.
31.75	142.	12.	3485.	81.	0.	7500.
32.00	156.	9.	2788.	81.	0.	7500.
32.25	160.	12.	3485.	81.	0.	7500.
32.50	160.	12.	3485.	81.	0.	7500.
32.75	160.	14.	4181.	81.	0.	7500.
33.00	148.	12.	3485.	81.	0.	7500.
33.25	146.	12.	3485.	81.	0.	7500.
33.50	146.	12.	3485.	81.	0.	7500.
33.75	154.	14.	4181.	81.	0.	7500.
34.00	152.	12.	3485.	81.	0.	7500.
34.25	150.	14.	4181.	81.	0.	7500.
34.50	152.	14.	4181.	81.	0.	7500.
34.75	148.	12.	3485.	81.	0.	7500.
35.00	150.	9.	2788.	81.	0.	7500.
35.25	150.	12.	3485.	81.	0.	7500.
35.50	150.	14.	4181.	81.	0.	7500.
35.75	162.	16.	4878.	81.	0.	7500.
36.00	156.	14.	4181.	81.	0.	7500.
36.25	155.	16.	4878.	81.	0.	7500.
36.50	158.	12.	3485.	81.	0.	7500.
36.75	156.	14.	4181.	81.	0.	7500.
37.00	152.	14.	4181.	81.	0.	7500.
37.25	156.	14.	4181.	81.	0.	7500.
37.50	158.	12.	3485.	81.	0.	7500.
37.75	160.	14.	4181.	81.	0.	7500.
38.00	158.	14.	4181.	81.	0.	7500.
38.25	162.	14.	4181.	81.	0.	7500.
38.50	162.	14.	4181.	81.	0.	7500.
38.75	154.	16.	4878.	81.	0.	7500.

TEST #5 SIZE 204 BEARING WITH SELF LUBRICATING CID-111 SHROUDED CPR RETAINER

TEST TIME HOURS	OUTER RACE TEMP - F	TORQUE IN.OZ.	HEAT GEN BTU/HOUR	AXIAL LOAD-LBS.	RADIAL LOAD-LBS	SPEED RPM
39.00	156.	16.	4878.	81.	0.	7500.
39.25	174.	18.	5575.	81.	0.	7500.
39.50	146.	12.	3485.	81.	0.	7500.
39.75	140.	14.	4181.	81.	0.	7500.
40.00	136.	9.	2788.	81.	0.	7500.
40.25	132.	14.	4181.	81.	0.	7500.
40.50	152.	16.	4878.	81.	0.	7500.
40.75	150.	14.	4181.	81.	0.	7500.
41.00	156.	18.	5575.	81.	0.	7500.
41.25	160.	16.	4878.	81.	0.	7500.
41.50	140.	14.	4181.	81.	0.	7500.
41.75	156.	14.	4181.	81.	0.	7500.
42.00	156.	14.	4181.	81.	0.	7500.
42.25	164.	16.	4878.	81.	0.	7500.
42.50	170.	18.	5575.	81.	0.	7500.
42.75	180.	16.	4878.	81.	0.	7500.
43.00	180.	14.	4181.	81.	0.	7500.
43.25	150.	12.	3485.	81.	0.	7500.
43.50	150.	12.	3485.	81.	0.	7500.
43.75	152.	12.	3485.	81.	0.	7500.
44.00	162.	14.	4181.	81.	0.	7500.
44.25	164.	14.	4181.	81.	0.	7500.
44.50	164.	16.	4878.	81.	0.	7500.
44.75	164.	14.	4181.	81.	0.	7500.
45.00	164.	14.	4181.	81.	0.	7500.
45.25	155.	18.	5575.	81.	0.	7500.
45.50	176.	21.	6272.	81.	0.	7500.
45.75	158.	16.	4878.	81.	0.	7500.

AVERAGE BEARING OUTER RACE TEMPERATURE = 141.17 F

AVERAGE BEARING TORQUE = 9.80 OUNCE-INCHES

AVERAGE HEAT GENERATION RATE = 2968. BTU/HOUR