

AD-A053 357

NAVAL RESEARCH LAB WASHINGTON D C
REFLECTIVE BUTLER MATRICES.(U)
MAR 78 J P SHELTON, J K HSIAO
NRL-8188

F/6 9/5

UNCLASSIFIED

NL

| OF |
AD
A053357



END
DATE
FILMED
6-78
DDC

AD A 053357

12

NRL Report 8188

2

Reflective Butler Matrices

J. PAUL SHELTON and JAMES K. HSIAO

*Target Characteristics Branch
Radar Divison*

March 14, 1978

AD No.

DDG FILE COPY



DDC
REFILED
MAY 2 1978
REGITLED

A

NAVAL RESEARCH LABORATORY
Washington, D.C.

Approved for public release; distribution unlimited.

UNCLASSIFIED

SECURITY CLASSIFICATION OF THIS PAGE (When Data Entered)

REPORT DOCUMENTATION PAGE		READ INSTRUCTIONS BEFORE COMPLETING FORM	
1. REPORT NUMBER NRL 8188	2. GOVT ACCESSION NO.	3. RECIPIENT'S CATALOG NUMBER	
4. TITLE (and Subtitle) REFLECTIVE BUTLER MATRICES		5. TYPE OF REPORT & PERIOD COVERED Interim report on a continuing NRL problem.	
7. AUTHOR(s) J. Paul Shelton James K. Hsiao		6. PERFORMING ORG. REPORT NUMBER	
9. PERFORMING ORGANIZATION NAME AND ADDRESS Naval Research Laboratory Washington, D.C. 20375		8. CONTRACT OR GRANT NUMBER(s) RR02105	
11. CONTROLLING OFFICE NAME AND ADDRESS Office of Naval Research Arlington, VA 22217		10. PROGRAM ELEMENT, PROJECT, TASK AREA & WORK UNIT NUMBERS NRL Problem R12-46.101 RR0210541 61153N	
14. MONITORING AGENCY NAME & ADDRESS (if different from Controlling Office) 30pp.		12. REPORT DATE March 1978	
		13. NUMBER OF PAGES 30	
		15. SECURITY CLASS. (of this report) UNCLASSIFIED	
16. DISTRIBUTION STATEMENT (of this Report) Approved for public release; distribution unlimited			
17. DISTRIBUTION STATEMENT (of the abstract entered in Block 20, if different from Report)			
18. SUPPLEMENTARY NOTES			
19. KEY WORDS (Continue on reverse side if necessary and identify by block number) Antenna arrays Matrix feed networks Multiple beams			
20. ABSTRACT (Continue on reverse side if necessary and identify by block number) A conventional Butler matrix can be modified to achieve a network which is symmetric about an axis midway between the input and output lines. Such a Butler matrix network can be cut in that plane of symmetry so that the input and output ports are identical. In this manner, the half-matrix corresponds to a reflection-type system in which the feed positions are in the aperture region. This report describes the modifications which symmetrize the Butler matrix and the method for cutting the network on the symmetry plane so as to achieve a reflective matrix. A computer program which generates and plots this network is presented.			

DD FORM 1 JAN 73 1473

EDITION OF 1 NOV 65 IS OBSOLETE
S/N 0102-LF-014-6601

UNCLASSIFIED
SECURITY CLASSIFICATION OF THIS PAGE (When Data Entered)

251 950

LB

SECURITY CLASSIFICATION OF THIS PAGE (When Data Entered)

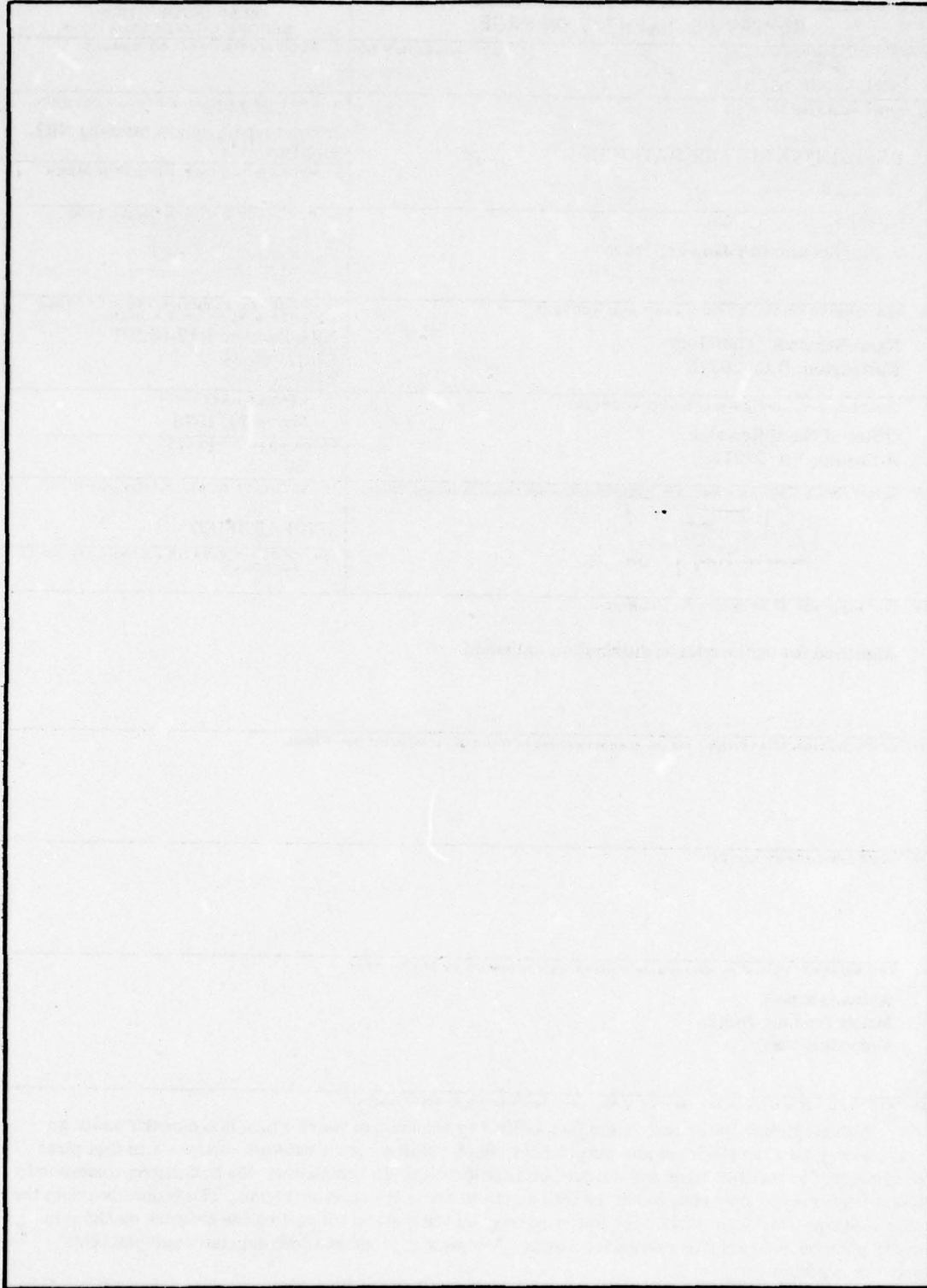

SECURITY CLASSIFICATION OF THIS PAGE (When Data Entered)

CONTENTS

INTRODUCTION	1
NETWORK AND RADIATION PATTERN CHARACTERISTICS OF A BUTLER-MATRIX-FED ARRAY	1
CONFIGURATION OF A BUTLER MATRIX	3
SYMMETRIZING THE BUTLER MATRIX	7
CUTTING THE MATRIX TO MAKE IT REFLECTIVE	12
CONCLUSIONS	15
REFERENCES	16
APPENDIX	17

ACCESSION No.		
DTIC	Unannounced	<input checked="" type="checkbox"/>
DDC	Ext. Service	<input type="checkbox"/>
UNANNOUNCED		<input type="checkbox"/>
JUSTIFICATION		
BY		
RESTRICTION/AVAILABILITY CODES		
Dist.	AVAIL.	and/or SPECIAL
A		

REFLECTIVE BUTLER MATRICES

1. INTRODUCTION

A conventional Butler matrix can be formed by use of symmetric 3-dB hybrid couplers [1]. Each matrix can be used as a building block for the next larger one. The configurations are symmetric about a longitudinal axis which divides the input and output ports into two halves, but except for the two smallest ones, they are not symmetric about an axis midway between input and output ports. Therefore, these matrices act as lenses in one direction. That is, the feed points correspond to a focal plane and the outputs correspond to the region of collimation. However, because of the lack of symmetry, the lens characteristic does not hold in the opposite direction; the output ports do not correspond to a focal plane with attendant collimation properties on the side of the input ports. It is evident that a matrix symmetric about an axis midway between the input and output ports is desirable. Such a matrix might be cut in that plane of symmetry so that the input and output ports would be identical. In this manner, the half-matrix would correspond to a reflection-type system in which the feed positions are in the plane of the aperture. Thus, the disadvantage incurred in achieving the saving of one-half of the components would be the necessity for switching the output between the feeds and the radiators or possibly avoiding feed blockage by the use of circulators.

In this report, the procedure for modifying a conventional Butler matrix to achieve a reflective network is presented.

2. NETWORK AND RADIATION PATTERN CHARACTERISTICS OF A BUTLER-MATRIX-FED ARRAY

For the reader who is unfamiliar with the operation of a Butler matrix, a brief review is given here. A Butler matrix is a $2N$ -port network, where $N = 2^p$ (p is an integer). All ports are matched, and the N ports on one side are mutually isolated, as are the N ports on the other side. The power transfer coefficient between any port on one side and any port on the other side is $1/N$. One set of N ports is termed the inputs, and the other set is termed the outputs. If power is fed into any of the input ports, it is split uniformly among the N output ports, without loss. For each input port used, there will be a particular phase distribution among the output ports. For appropriate ordering of the output ports, all of the phase distributions are linear; that is, if the output ports are numbered $n = 1, 2, \dots, N$, the phase difference between ports n and $n - 1$ is constant for all n . This constant is different for each input port. If the input ports are numbered $m = 1, 2, \dots, N$, the phase difference can be expressed

$$\Delta\phi_m = \phi_0 + 2\pi m/N,$$

Manuscript submitted November 22, 1977.

SHELTON AND HSIAO

where ϕ_0 is a selectable constant, which is fixed for all m .

The transfer phase from port m to port n can be expressed as

$$\phi_{mn} = \phi_m + n(\phi_0 + 2\pi m/N),$$

where ϕ_m is a selectable constant for each value of m .

The value of ϕ_0 is generally determined by the desired application for the network. For example, matrix-fed circular arrays require cyclic output phase distributions for which $\phi_0 = 0$. The networks presented in this report have $\phi_0 = \pi/N$ as a result of the symmetry imposed upon them. It is noted that ϕ_0 can be altered to any desired value for any given network simply by adding an appropriate set of linearly increasing phase shifts to the output ports.

If the output ports are connected to a linear antenna array, the uniform amplitude and phase distribution generated by any input will produce a directive radiation pattern of the form

$$E(\mu) = \frac{\sin N(\mu - \mu_0)}{N \sin(\mu - \mu_0)},$$

where

$$\mu = 2\pi d \sin \theta / \lambda,$$

with

$$d = \text{interelement spacing,}$$

$$\lambda = \text{wavelength,}$$

$$\theta = \text{angle relative to normal to the array,}$$

and where

$$\mu_0 = 2\pi d \sin \theta_0 / \lambda = \Delta\phi_m, \text{ and}$$

$$\theta_0 = \text{beam direction.}$$

The resulting multipoint antenna system, consisting of an N -element array connected to a $2N$ -port Butler matrix, has N ports, each of which produces a beam. It can be shown that the multiple antenna patterns form an orthogonal set, as do the output distributions to the array. A beam corresponds to an aperture distribution and also to a particular input port.

The network with the above characteristics which uses a minimum number of components is a Butler matrix. This network is closely analogous to the fast Fourier transform [2]. In the analysis presented here, the networks will be generated using 3-dB hybrid directional couplers, although other types of four-port hybrid networks can also be used.

3. CONFIGURATION OF A BUTLER MATRIX

Figure 1(a) shows the configuration of a 3-dB hybrid directional coupler, which has four ports and $N = 2$. Inputs 1 and 2 form two beams in the directions $\mu_0 = \pm 90^\circ$. A network with $N = 4$ can be formed from the fundamental hybrid coupler as shown in Fig. 1(b). Four beams can be formed, and they are pointed at $\mu_0 = \pm 45^\circ, \pm 135^\circ$. In general, networks with larger numbers of input ports can be formed from networks with fewer ports. As an example, we shall show how a 16-port Butler matrix can be formed from 4-port matrices. First, we recognize that a four-port matrix ($N = 4$) transforms four inputs into four distinct beams evenly distributed in μ space. Therefore, we initially require four blocks (each block is a four-port matrix) connected as shown in Fig. 2(a). Outputs of block 1 become outputs 1, 5, 9, and 13, and those of block 2 become outputs 2, 6, 10, and 14, etc. An additional row of four 4-port matrices is required to combine the inputs of these four blocks. The connection of these matrices to the first-row blocks is shown in Fig. 2(b). The first inputs of the four blocks in the first row are connected to block 1 of the second row, and four inputs are formed: 1, 5, 9, and 13. Since the beam-pointing directions (or phase gradients) of the 16-port matrix are different from those of the 4-port matrix, additional phase shift must be provided to make up this difference. For example, input 1 of the block has a phase gradient of -45° , but in a 16-port matrix, the phase gradient of the first input is -11.25° . To account for this difference, phase shifts of $33.75^\circ, 67.5^\circ,$ and 101.25° are required for the second, third, and fourth output lines of the first block in the second row, respectively. The inputs of this block now form beams pointing in the directions $\mu_0 = -11.25^\circ, -101.25^\circ, 168.75^\circ,$ and 78.75° . Similar additional phases are required for blocks 2, 3, and 4 of the second row. The input lines of the overall network are then interwoven to be symmetric with the output lines.

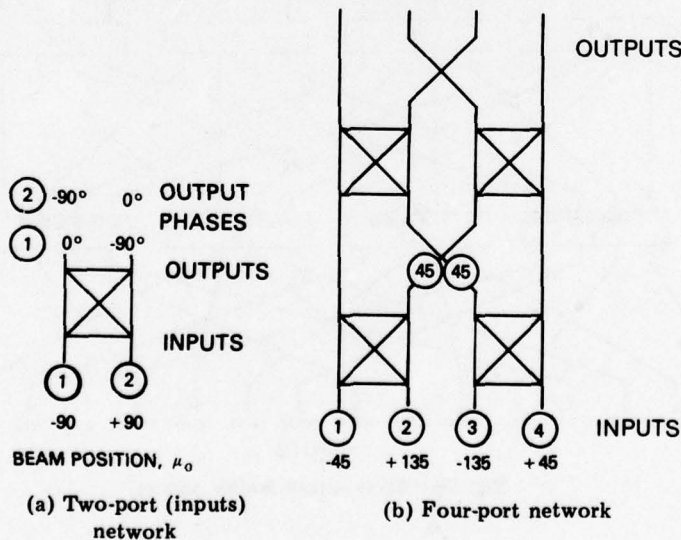

Fig. 1 —Butler matrices for $N = 2$ and $N = 4$

SHELTON AND HSIAO

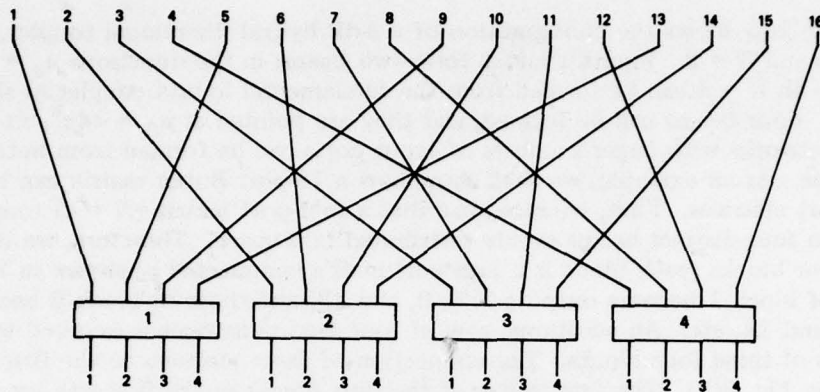

Fig. 2a — First row of a Butler matrix using four-port matrices as building blocks

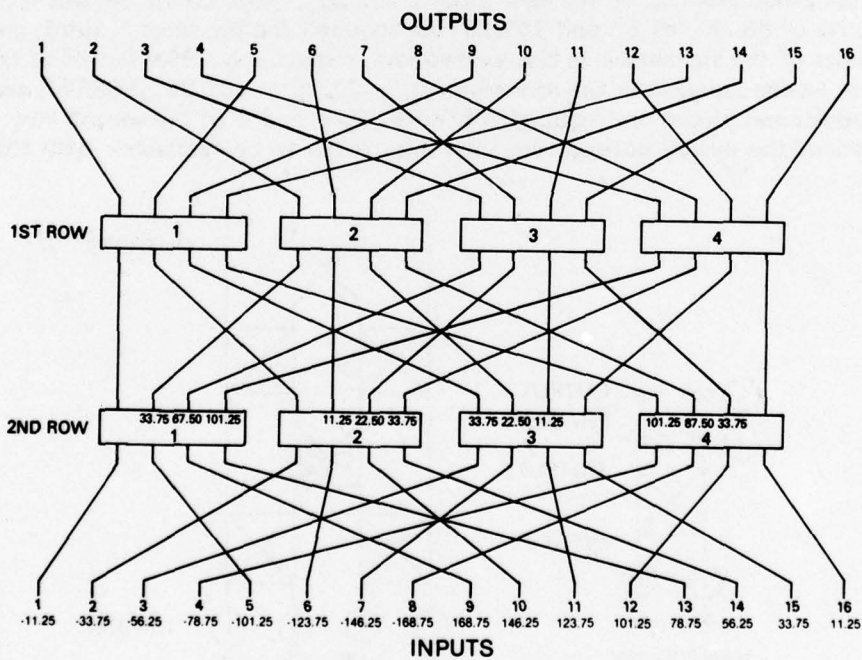

Fig. 2b —Sixteen-port Butler matrix

In general, the matrix network layout and connections can be described by the following procedures [3]:

- The product of the number of matrices in each row and the number of ports in each matrix block is equal to the total number of ports.

- Let the rows be numbered $1, 2, \dots, P$. Let the blocks in the i th row have L_i ports. The total number of ports in the matrix is $N = \prod_{i=1}^P L_i$, and the number of blocks in the i th row is $M_i = \prod_{j=1, j \neq i}^P L_j$, where the prime indicates that the factor for $j = i$ is omitted.

- A variety of procedures can be established for interconnecting the blocks in successive rows of the overall matrix, exactly analogous with the variety of flow diagrams available for the fast Fourier transform [4]. A simple procedure is described here: The rows to be connected are i and $i + 1$; the block sizes are L_i and L_{i+1} , and the numbers of blocks in each row are M_i and M_{i+1} , where $L_i M_i = L_{i+1} M_{i+1} = N$. The outputs of the blocks in row $i + 1$ are connected with the inputs of the blocks in row i , which are numbered sequentially 1 through N . The outputs of the first block in row $i + 1$ are connected to inputs 1, $M_{i+1} + 1$, $2M_{i+1} + 1$, etc. The outputs of the second block are connected to inputs 2, $M_{i+1} + 2$, $2M_{i+1} + 2$, etc. In general, the outputs of the j th block in row $i + 1$ are connected to inputs $j + kM_{i+1}$, where $k = 0$ through $L_{i+1} - 1$.

- It is now necessary to determine the transmission-line phase shifts which must be added to ensure beam collimation for all input ports. For the blocks in the first row, which have L_1 ports, the beam-pointing directions when one of these blocks is connected to an L_1 -element array (if L_1 is even) are $\mu_0 = \pm\pi/L_1, \pm 3\pi/L_1$, etc., with a spacing in μ of $2\pi/L_1$. If L_1 is odd, $\mu_0 = 0, \pm 2\pi/L_1, \pm 4\pi/L_1$, etc.* Since the output ports of the first-row blocks are fed to elements with spacings increased by a factor of M_1 , the beam maxima are at $\mu_0 = \pm\pi/M_1 L_1, \pm 3\pi/M_1 L_1$, etc., or $\mu_0 = \pm\pi/N, \pm 3\pi/N$, etc.; it is also seen that the beams from a single block exhibit grating lobes. Appropriate phase shifts must be inserted in the interconnecting lines so that a selected grating lobe is reinforced by contributions from all blocks in a row and all other grating lobes are suppressed. As in the case of the interconnecting line geometry, there are various procedures for achieving this result. Throughout this report we have chosen to generate an innermost beam from an outermost matrix port. The general procedure for determining the phase shifts to be inserted in the output lines of any given block, after one selects a beam position for a given overall matrix input port, is to set down the required output phase distribution for the overall matrix. Then the block outputs in any given row can be independently adjusted for the very important reason that the net transmission phases for all outputs of any block through the remaining rows of the matrix are identical.

This procedure has been programmed in FORTRAN language, and the program is described and listed in the Appendix. Sample computer plots are shown in Fig. 3, with $N = 32$, $L_1 = 4$, $L_2 = 2$, $L_3 = 4$, and in Fig. 4, with $N = 64$, $L_1 = L_2 = 8$. Since the

*Although N is a power of two for the conventional Butler matrix, we assume in this discussion that L_i , the factors of N , can be arbitrarily chosen.

SHELTON AND HSIAO

matrix is symmetric about a longitudinal axis, only the left half of the matrix is shown. Tables 1 and 2 list the phase-shift values that must be inserted in the outputs of the indicated rows of the matrices shown in Figs. 3 and 4, respectively. The phase-shift values are listed in the tables from left to right, corresponding to the output ports of the indicated rows, taken in order from left to right in the figures. Figures 3 and 4 plot the left halves of right-left symmetric matrices, and Tables 1 and 2 list phase-shift values for full matrices. Note the symmetry of the phase-shift listings.

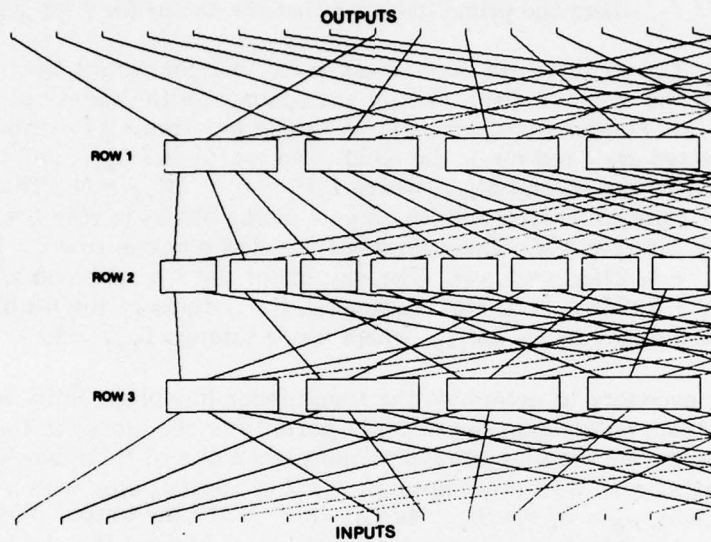

Fig. 3 — Left half of a 32-port Butler matrix

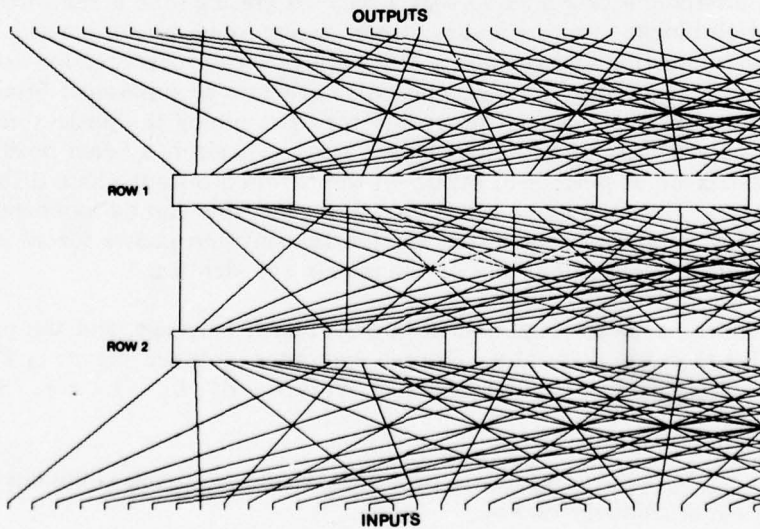

Fig. 4 — Left half of a 64-port Butler matrix

NRL REPORT 8188

Table 1 — Phase Shifts for 32-port Matrix,
Inserted in Outputs of Indicated Rows.

ROW 2				
0.0000	67.5000	0.0000	22.5000	22.5000
0.0000	67.5000	0.0000	0.0000	67.5000
0.0000	22.5000	22.5000	0.0000	67.5000
0.0000	0.0000	67.5000	0.0000	22.5000
22.5000	0.0000	67.5000	0.0000	0.0000
67.5000	0.0000	22.5000	22.5000	0.0000
67.5000	0.0000			
ROW 3				
0.0000	39.3750	78.7500	118.1250	0.0000
28.1250	56.2500	84.3750	0.0000	16.8750
33.7500	50.6250	0.0000	5.6250	11.2500
16.8750	16.8750	11.2500	5.6250	0.0000
50.6250	33.7500	16.8750	0.0000	84.3750
56.2500	28.1250	0.0000	118.1250	78.7500
39.3750	0.0000			

Table 2 — Phase Shifts for 64-Port Matrix,
Inserted in Outputs of Second Row.

0.0000	19.6875	39.3750	59.0625	78.7500
98.4375	118.1250	137.8125	0.0000	14.0625
28.1250	42.1875	56.2500	70.3125	84.3750
98.4375	0.0000	8.4375	16.8750	25.3125
33.7500	42.1875	50.6250	59.0625	0.0000
2.8125	5.6250	8.4375	11.2500	14.0625
16.8750	19.6875	19.6875	16.8750	14.0625
11.2500	8.4375	5.6250	2.8125	0.0000
59.0625	50.6250	42.1875	33.7500	25.3125
16.8750	8.4375	0.0000	98.4375	84.3750
70.3125	56.2500	42.1875	28.1250	14.0625
0.0000	137.8125	118.1250	98.4375	78.7500
59.0625	39.3750	19.6875	0.0000	

4. SYMMETRIZING THE BUTLER MATRIX

The modification of the matrices to a symmetric reflection form is accomplished in three phases. First, the network must be rearranged so that the hybrid couplers and interconnecting lines are symmetric about the midline of the matrix, without regard to any of the phase shifters in the interconnecting lines. Second, a scheme for modifying the

SHELTON AND HSIAO

phase shifters to achieve symmetry about the midline is required. Finally, a method whereby the matrix can actually be cut in two is necessary.

The method of achieving topological symmetry is based on the requirement for a fixed arrangement of the output ports, determined by the output phase distributions, with the accompanying "natural" arrangement of the output couplers. This allows us to arrange the inputs and input rows of couplers in the same fashion, as shown in Figure 5(a) for the 8-port matrix. The next step is to determine the locations for the middle row of hybrids. This is accomplished by averaging the positions of the four hybrids to which each middle-row hybrid is connected. The result, shown in Figure 5(b), is two centered hybrids and two off-center. The network is now seen to be topologically symmetric.

It is necessary to modify the phase shifts so that the network is completely symmetric about the midline. It is first required to find an additional degree of freedom beyond what was used in the conventional Butler matrix; that is, all phase shifts were inserted in the interior of the network—but there is no reason why additional phase shifts cannot be inserted in both outputs of any of the output couplers and correspondingly in both of the input transmission lines to any of the input couplers.

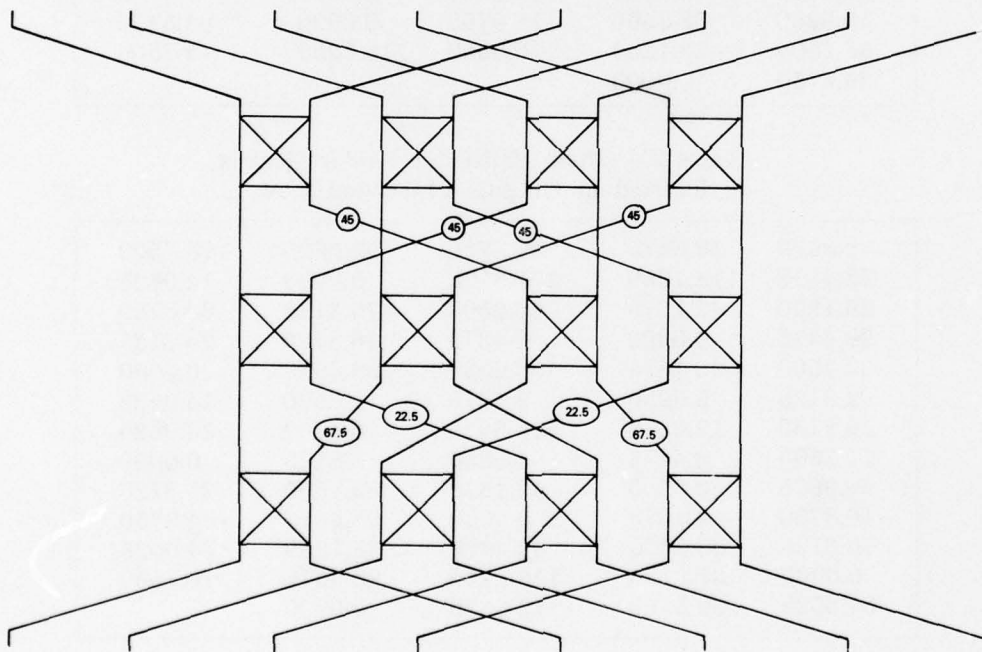

Fig. 5a —Symmetric arrangement of input and output couplers and ports

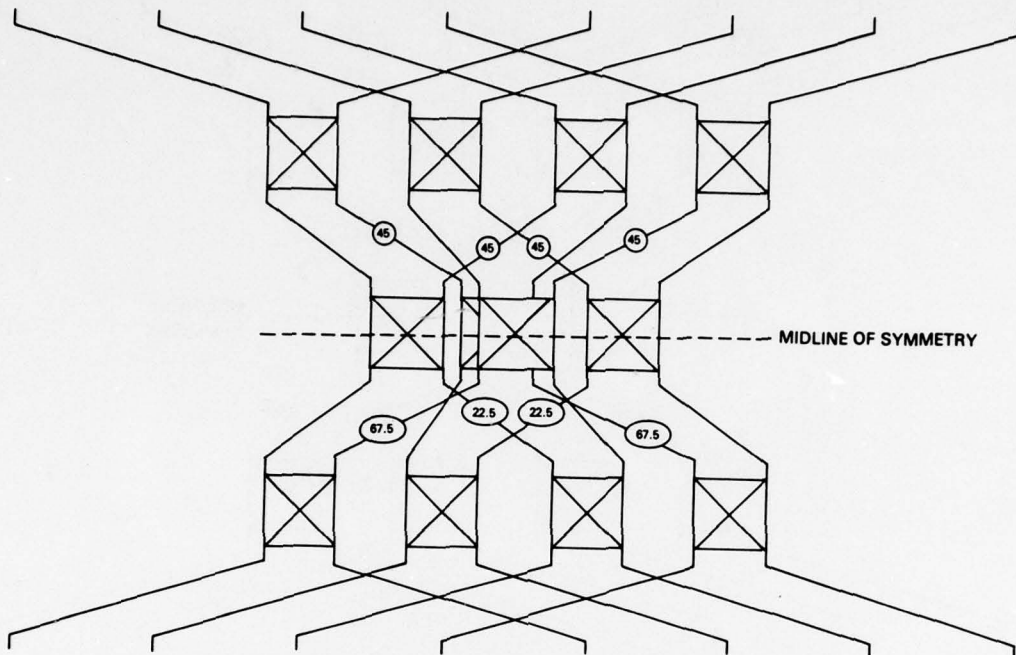

Fig. 5b —Location of middle couplers and symmetric layout of eight-port matrix

With this added degree of freedom, it is now possible simply to average the symmetrically located phase shifts in the interior of the matrix of Figure 5(b). When a pair of phase shifts are averaged, it is necessary to determine the value of the compensating phase shift to be added to the outputs and inputs of the matrix. Since the relative output phase distribution is fixed, one needs only to calculate the phase shift of any one output line from a block, and the remaining output line(s) from that block will be automatically correct with the same phase shift. It is also noted that adding a phase shift to an input line of a block does not alter the relative phase gradient produced by that block. In the case of the eight-port network, this compensating phase shift is $+11.25^\circ$ inserted in the outputs of the second and third blocks of the first row. The resulting completely symmetric network is shown in Fig. 5(c).

The objective with larger matrices is to generate them by some procedure that does not increase in complexity as the matrix increases in size. For example, a conventional Butler matrix with N ports can be formed from two of the next smaller matrices with $N/2$ ports plus a row of hybrid couplers. It is also possible to devise building-block techniques for symmetric matrices. Three arrangements for a 16-port matrix are shown in Fig. 6. Figure 6(a), with all $L_i = 2$, is the symmetric layout for four rows of hybrid couplers; not only was the layout difficult to deduce, but there are two or three degrees of freedom in the phase-shift adjustment. In Fig. 6(b), two rows of four-port networks are used. The matrix of Fig. 6(c) has a middle row of four-port networks and top and bottom rows of hybrid couplers.

SHELTON AND HSIAO

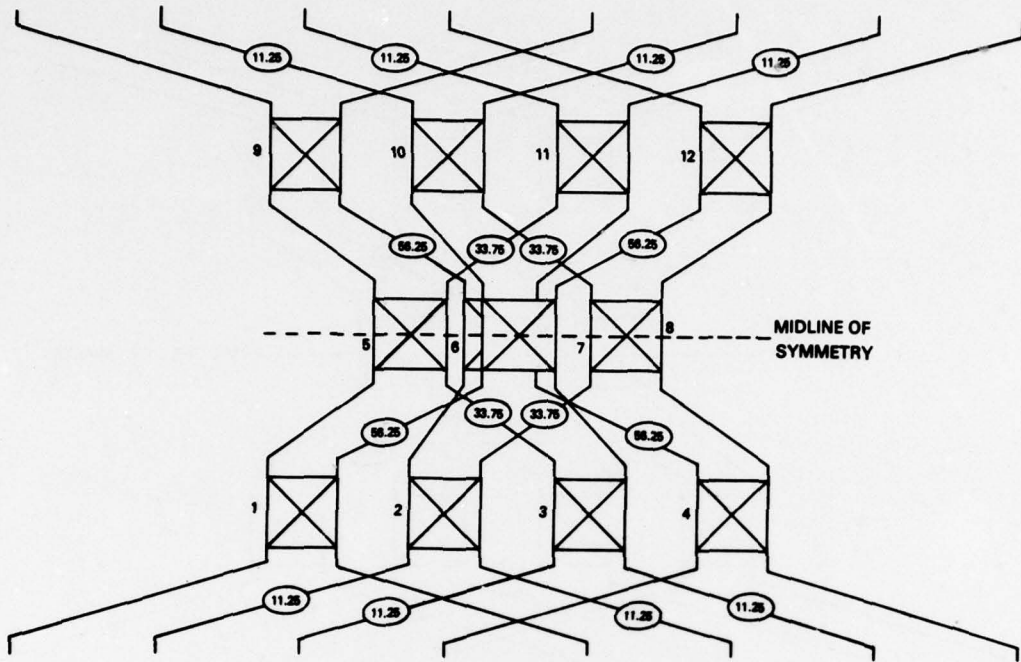

Fig. 5c — Symmetric eight-port Butler matrix

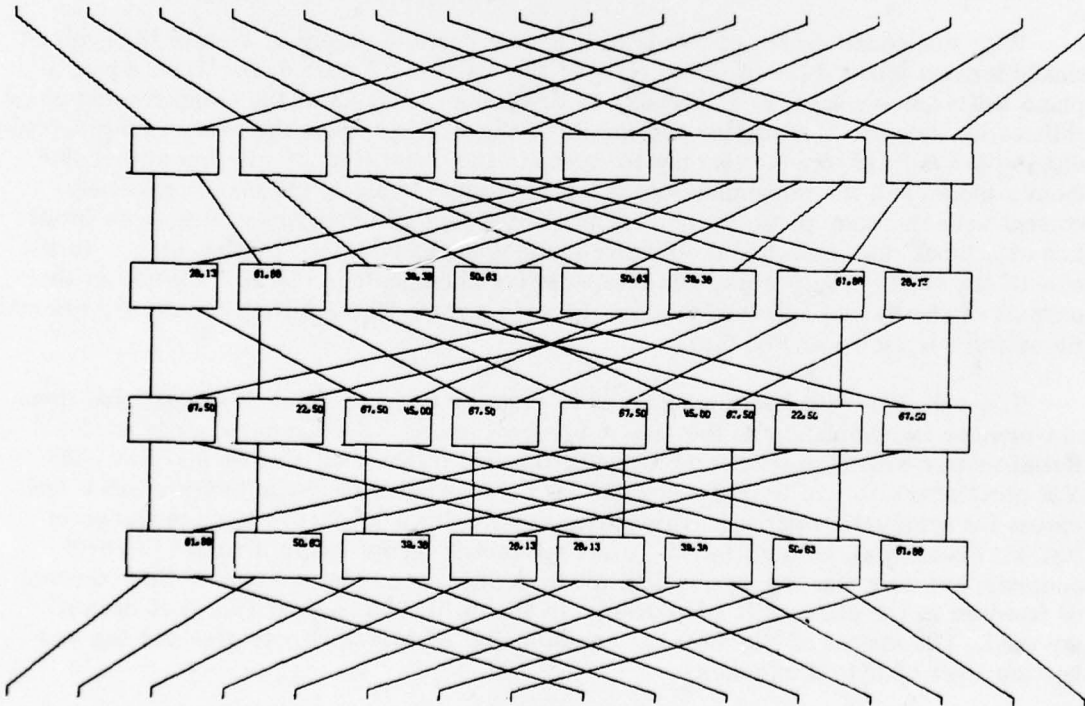

Fig. 6a — Symmetric 16-port matrix using four rows of hybrid couplers

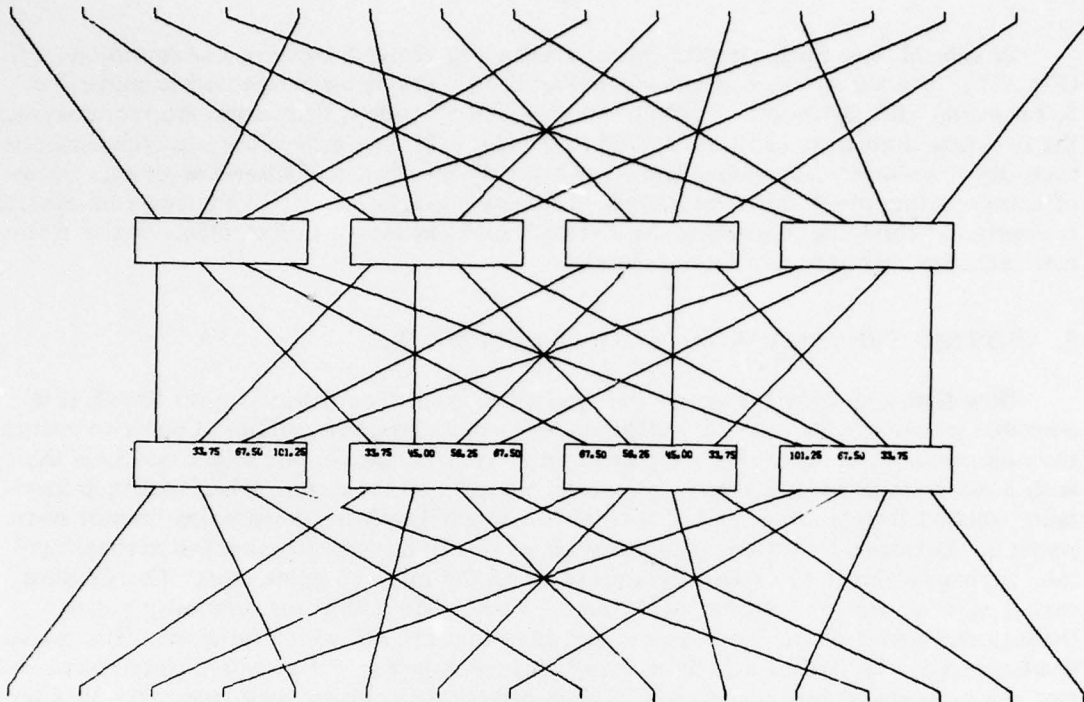

Fig. 6b —Symmetric 16-port matrix using 4-port building blocks

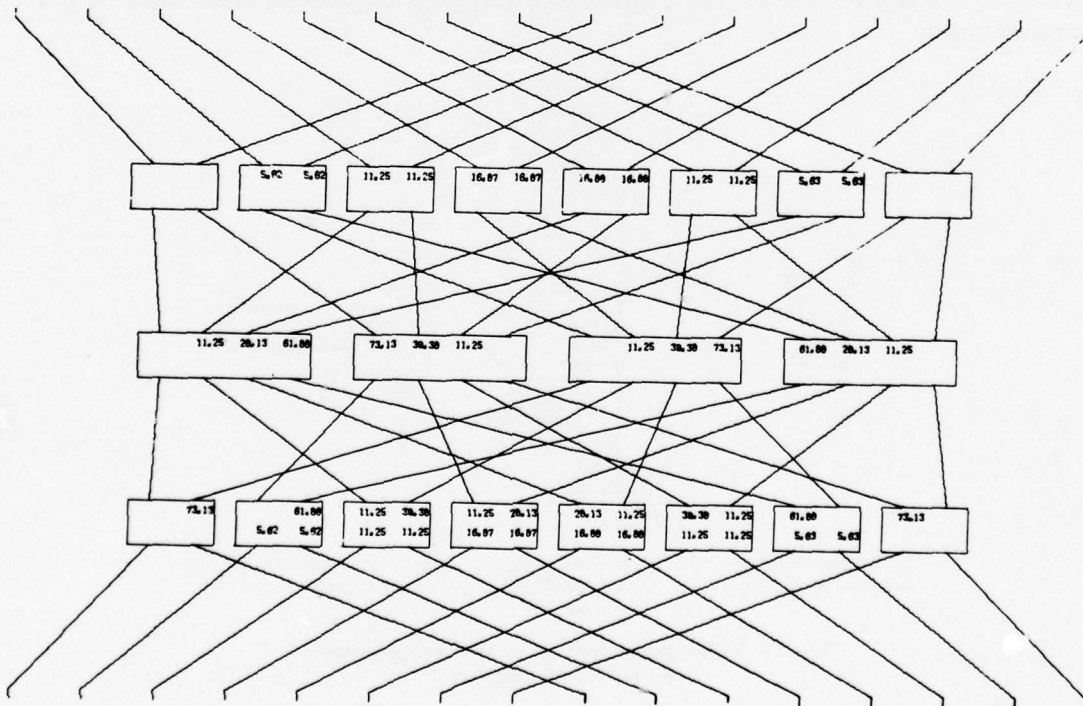

Fig. 6c —Symmetric 16-port matrix using one row of 4-port and two rows of 2-port building blocks

In general, any Butler matrix can be realized by either a two-row configuration (Fig. 6(b)) or a three-row configuration (Fig. 6(c)). The two-row method is applicable to networks with 2^{2n} ports. For networks with 2^{2n+1} ports, three rows are required, and the first and third rows can use couplers: $L_1 = L_3 = 2$. For a two-row configuration, the topology is automatically symmetric. For both the two-row and three-row cases, one set of compensating phase shifts can be added to establish symmetry. In the two-row case, it is inserted in the lines connecting the rows of blocks as shown in Fig. 6(b). In the three-row case, the averaging procedure is used.

5. CUTTING THE MATRIX TO MAKE IT REFLECTIVE

Now that a method for generating symmetric Butler matrices has been found, it is desirable to devise a method for cutting them in two along the midline in order to reduce the number of components by a factor of two. At first glance, one might conclude that such a cut is impossible, because, in general, one part of the resulting half-matrix is inevitably isolated from another part if the cut is a simple break in transmission lines or components. However, let us first examine what can be done with the simplest matrices and then perhaps attempt to extend the procedure to the more complex ones. The simplest matrix is, of course, the 3-dB hybrid coupler itself. The midline of symmetry passes through the center of the coupler, and it is here that the cut would be made. The question is what constitutes half of a 3-dB coupler? It is seen in Fig. 7 that a 3-dB directional coupler can be replaced by two cascaded 8.3-dB directional couplers, with the result that the midline of symmetry now crosses the two transmission lines joining the 8.3-dB couplers. Therefore, the half-matrix for the simplest case is simply an 8.3-dB coupler with outputs open-circuited.

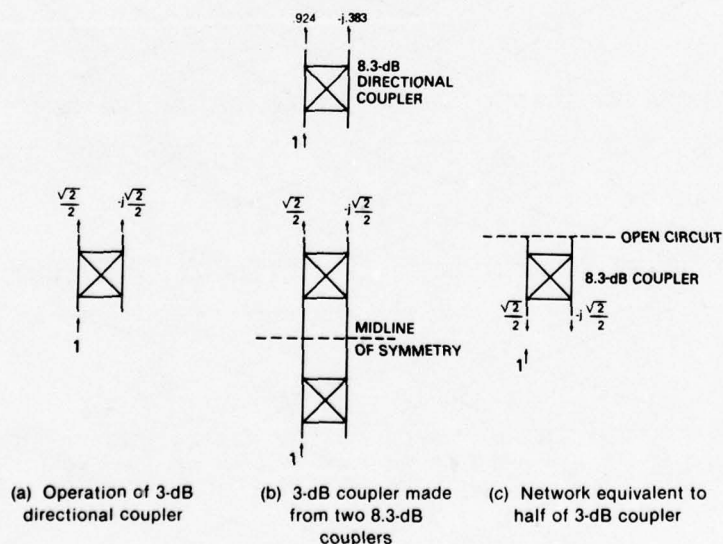

Fig. 7 —3-dB coupler realized as symmetric cascade of two 8.3-dB couplers

If we consider next the four-port Butler matrix, shown in Fig. 8(a), the midline of symmetry for this case passes through the interconnecting transmission lines between directional couplers. It is seen that if these lines are simply cut, the result is two isolated 3-dB couplers with open-circuited outputs. It is found that the only alternative is to join the two transmission lines that cross at the midline, as shown in Fig. 8(b).

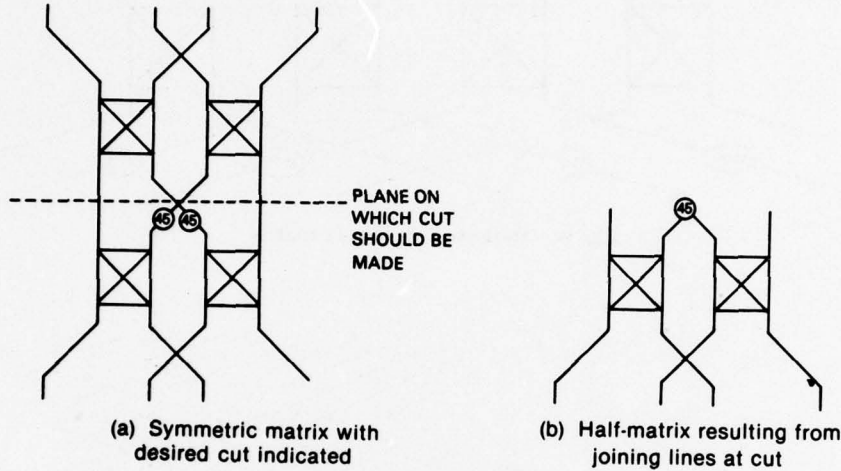

Fig. 8 - Half four-port matrix illustrating method of making cut

The general rule that emerges from these simple examples is that transmission lines and couplers are cut on the midline of symmetry of the matrix but any lines or components which are crossed or superimposed on the midline are not open-circuited but are joined together. Further results of the application of this rule are shown in Fig. 9 for $N = 8$, in Fig. 10 for $N = 32$ with $L_1 = L_3 = 2$, $L_2 = 8$, and in Fig. 11 for $N = 64$ with $L_1 = L_2 = 8$. Tables 3 and 4 list the phase shifts for the 32-port and 64-port reflective matrices, respectively. The phase-shift values are listed in the tables from left to right, corresponding to the output ports of the indicated rows, taken in order from left to right in the figures. Figures 10 and 11 plot the left halves of right-left symmetric configurations and Tables 3 and 4 list phase-shift values for both halves, with resultant symmetry in the listings. Since 7/8 of the inputs to row 1 of Fig. 11 are interconnected, the values listed in Table 4 reflect those interconnections. Thus, the phase shifts for lines 2 and 9 are the same, as are 3 and 17, 4 and 25, etc.

It is possible to verify the operation of these networks by tracking signal paths from any input port through the network to all input ports. A result of this reflective operation is that $1/N$ of the input power returns to the input port, thereby mismatching it. Thus, the input voltage standing-wave ratio (VSWR) of a reflective matrix is given by

$$S = \frac{\sqrt{N} + 1}{\sqrt{N} - 1}$$

SHELTON AND HSIAO

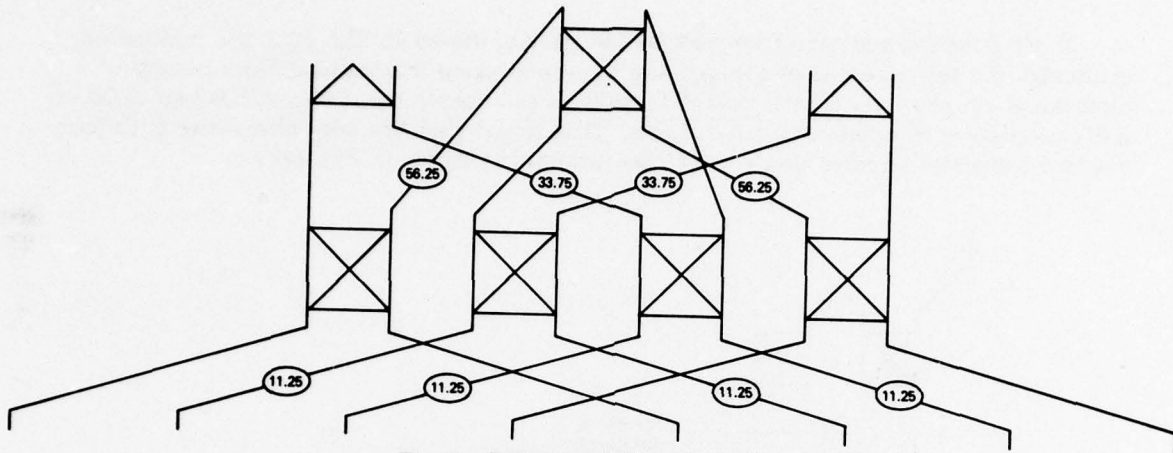

Fig. 9 — Reflective eight-port matrix

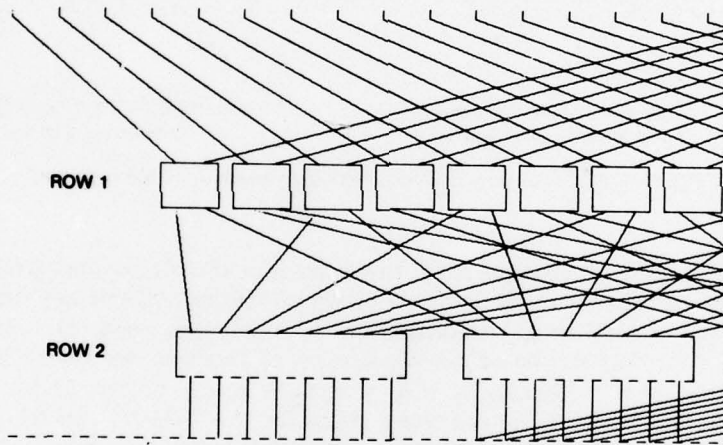

Fig. 10 — Left half of a reflective 32-port Butler matrix

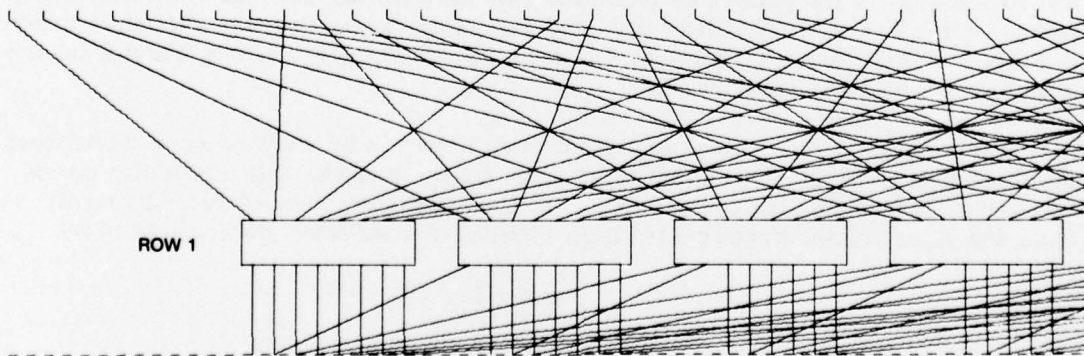

Fig. 11 — Left half of a reflective 64-port Butler matrix

NRL REPORT 8188

Table 3 — Phase Shifts for Reflective 32-Port Matrix.

ROW 1				
0.0000	0.0000	0.0000	0.0000	19.6875
19.6875	19.6875	19.6875	28.1250	28.1250
28.1250	28.1250	25.3125	25.3125	25.3125
25.3125	25.3125	25.3125	25.3125	25.3125
28.1250	28.1250	28.1250	28.1250	19.6875
19.6875	19.6875	19.6875	0.0000	0.0000
0.0000	0.0000			
ROW 2				
0.0000	42.1875	19.6875	16.8750	50.6250
2.8125	92.8125	0.0000	0.0000	59.0625
14.0625	28.1250	39.3750	8.4375	75.9375
0.0000	0.0000	75.9375	8.4375	39.3750
28.1250	14.0625	59.0625	0.0000	0.0000
92.8125	2.8125	50.6250	16.8750	19.6875
42.1875	0.0000			

Table 4 — Phase Shifts for Reflective 64-Port Matrix
Inserted in Inputs of Row 1.

0.0000	19.6875	39.3750	59.0625	78.7500
98.4375	118.1250	137.8125	19.6875	33.7500
47.8125	61.8750	75.9375	90.0000	104.0625
118.1250	39.3750	47.8125	56.2500	64.6875
73.1250	81.5625	90.0000	98.4375	59.0625
61.8750	64.6875	67.5000	70.3125	73.1250
75.9375	78.7500	78.7500	75.9375	73.1250
70.3125	67.5000	64.6875	61.8750	59.0625
98.4375	90.0000	81.5625	73.1250	64.6875
56.2500	47.8125	39.3750	118.1250	104.0625
90.0000	75.9375	61.8750	47.8125	33.7500
19.6875	137.8125	118.1250	98.4375	78.7500
59.0625	39.3750	19.6875	0.0000	

6. CONCLUSIONS

In this report, the generation of a Butler matrix from 3-dB couplers or larger building blocks has been discussed. Such a matrix has been made symmetric by first rearranging the blocks and then inserting appropriate compensating phase shifts. Finally, a reflective configuration has been realized by applying rules for cutting along the midline of symmetry. A program for generating and plotting these matrices has been written.

REFERENCES

1. J.P. Shelton and K.S. Kelleher, "Multiple Beams from Linear Arrays," Trans. IRE AP-9, (No. 1), 154-161, (Mar. 1961).
2. J.P. Shelton, "Fast Fourier Transforms and Butler Matrices," Proc. IEEE 56. (No. 3), 350, (Mar. 1968).
3. H. J. Moody, "The Systematic Design of the Butler Matrix," Trans IEEE AP-12, (No. 6) 786-788, (Nov. 1964).
4. G-AE Subcomm. on Meas. Conc., "What is the Fast Fourier Transform?" IEEE Trans. AU-15, 45-55, (June 1967).

Appendix

A listing of the computer program used in this report to plot both a conventional Butler matrix and a reflective matrix is included in this appendix. If the number of ports, the size of the basic building blocks and the number of rows are specified, this program plots the interconnections and the relative phase shifts between building blocks. As an example, a 16-port Butler matrix network plotted by this program is shown in Fig. 6. To use this program, two data cards are required to enter the necessary information. The first data card enters the following fixed-point (I5 format) variables:

- NPT — Number of ports of the Butler matrix network to be plotted.
- NROW — Number of rows of this network.
- LL — A two-digit number to control what type of Butler matrix to be plotted.
The first digit conveys the following instruction:
 - 1 — Plot a conventional Butler matrix network;
 - 2 — Plot a symmetric Butler matrix network (symmetric about an axis midway between input and output ports);
 - 3 — Plot a reflective Butler matrix network;
 - 0 — Plot both a conventional and a reflective Butler matrix.

The second digit specifies how the plot is presented:

- 1 — Plot the matrix network without phase shifts (phase shifts will be printed);
- 2 — Plot only half of the array (left half);
- 0 — Plot the full network with phase shifts.

For example, if one sets LL = 23, since the "units" digit is 3, a reflective Butler matrix will be plotted. The "tens" digit, 2, specifies that only the left half of this matrix network will be plotted (without phase shifts).

- XMS — A floating-point number (use F10.6 format) to specify the size of the plot (in the x direction). The y direction is limited by the computer plotter to be 19 cm (7.5 in.). If XMS is set to be zero, the program automatically sets 1.9 cm (0.75 in.) between each two input ports and plots phase shifts between rows (ignoring the conditions set by LL). Thus, a 16-port network will be plotted at a size of 19 by 30.5 cm (7.5 in. by 12 in.).

The second data card specifies the number of ports in each basic building block in each row. For example, to plot the network shown in Figure 6(c), three numbers are required to be entered on the second data card: 2, 4, 2. Thus, eight 2-port blocks are used in the first and third rows of this network, and four 4-port blocks are used in the second row. This card also uses I5 fixed-point format.

SHELTON AND HSIAO

```

PROGRAM RTMTFFT
COMMON/2/PLTARRAY(254)
DIMENSION MC(5,512),PHA(5,512)
DIMENSION NBP(64),NBK(64)
CALL PLUTS(PLTARRAY,254,18)
KC=0
XM=0.
C   LLL=1, PLOT CONVENTIONAL FULL MATRIX
C   LLL=2, PLOT SYMMETRICAL FULL MATRIX
C   LLL=3, PLOT HALF MATRIX
C   LLL=0, PLOT ALL
C   IF LL.GT.10 PLOT MATRIX WITHOUT ANGLE
C   IF LL.GT.20 PLOT HALF
C   IF LL.GT.30 PLOT HALFMATRIX (IN Y DIRECTION) WITHOUT ANGLE
C   IF ANGLE IS TO BE PLOTTED SET XM EQU L TO ZERO
1  READ 100,NTP,NROW,LL,XMS
100 FORMAT(3I5,F10.6)
   IF(EOF,60)2,3
3   READ 101,(NBP(I),I=1,NROW)
101 FORMAT(16I5)
   LLL=MOD(LL,10)
   LHC=LL/10
   IF(XMS.LF.0.)XMS=XM
   XM=XMS
   PRINT 110,NTP
110 FORMAT(//,10X,*TOTAL NUMBER OF PORTS IS*,I5,/)
   PRINT 111,NROW
111 FORMAT(//,10X,*NUMBER OF ROWS IS*,I5,/)
   PRINT 112,(NBP(I),I=1,NROW)
112 FORMAT(10X,*NUMBER OF PORTS IN EACH BLOCK OF EACH ROW*,//,10X,5I5)
   IF(KC.GT.0)CALL PLOT(XM<.,0.,-3)
   KC=KC+1
   NR1=NROW+1
   CALL NTWK(NTP,NR1,NBP,NBK,MC,PHA)
   LP=0
   CALL PRTOUT(NTP,NR1,MC,PHA,LP)
   IF(LLL.GT.1)GO TO 4
   NH=LHC*10
   CALL NTWKPLT(NTP,NR1,NBP,NBK,NH,MC,PHA,XM)
   IF(LLL.GE.1)GO TO 1
   CALL PLOT(XM+2.,0.,-3)
4  CALL HLFMTX(NTP,NR1,NBP,NBK,MC,PHA)
   LP=1
   CALL PRTOUT(NTP,NR1,MC,PHA,LP)
   IF(LLL.GT.2)GO TO 5
   NH=LHC*10
   CALL NTWKPLT(NTP,NR1,NBP,NBK,NH,MC,PHA,XM)
   IF(LLL.GE.2)GO TO 1
   CALL PLOT(XM+2.,0.,-3)
5  CALL NTWKPLT(NTP,NR1,NBP,NBK,NH,MC,PHA,XM)
   GO TO 1
7  CALL STOP PLOT
   END

```

NRL REPORT 8188

```

SUBROUTINE NTWK(NTP,NR1, NBP,NRK,MC,PHA)
C*****THIS SUBROUTINE FINDS THE CONNECTION OF A BUTLER MATRIX OR FFT
C   GIVEN THE NUMBER OF ROWS AND THE NUMBER OF PORTS IN EACH BLOCK IN
C   EACH ROW
C*****COMPILED BY J. K. HSIAO
C*****FIRST VERSION IS COMPILED ON MAY 7,1976
C*****NTP, NUMBER OF TOTAL INPUT PORTS OR SAMPLES
C*****NR1, NUMBER OF ROWS REQUIRED TO PERFORM THE TRANSFORMATION
C*****NBP, AN ARRAY STORES THE NUMBER OF PORTS IN EACH BLOCK AT EACH
C   ROW. EACH BLOCK IN A ROW HAS THE SAME NUMBER OF PORTS
C*****NRK, AN ARRAY STORES THE NUMBER OF BLOCKS IN EACH ROW.
C*****MC, A TWO DIMENSIONAL ARRAY STORES THE CONNECTIONS OF THE NETWORK.
C   FIRST INDEX OF THE ARRAY REPRESENTS THE NUMBER OF CURRENT ROW. THE
C   LOCATION OF THE SECOND INDEX REPRESENTS THE PHYSICAL LOCATION OF
C   THE PREVIOUS ROW WHILE THE CONTENTS OF IT IS THE CONNECTION TO THE
C   CURRENT ROW
C   DIMENSION MC(NR1,NTP),PHA(NR1,NTP)
C   DIMENSION NPTS(5 2)
C   DIMENSION NRP(64 ),NRK(64 )
C   COMPUTES THE NUMBER OF PORTS IN EACH BLOCK
NR1=NR1-1
PI=3.1415926536
PI2=PI*2.
NBP(NR1)=1
NTP2=NTP/2
DO 10 I=1,NR1
10  NRK(I)=NTP/NBP(I)
C**** NPTS ARRAY STORES THE LOCATION OF THE SAMPLES IN EACH BEAM(OR
C   FREQUENCY SAMPLE). THE STRUCTURE IS CHARACTERIZED BY TWO NUMBERS,
C   NTS,NUMBER OF TIME SAMPLES(OR INPUT PORTS) AND NFS, NUMBER OF
C   FREQUENCY SAMPLES(OR NUMBER OF BEAMS). FOR EXAMPLE, NPTS((3-1)*
C   NTS+1) IS THE PHYSICAL LOCATION OF THE FIRST TIME SAMPLE IN THE
C   THIRD FREQUENCY GROUP( OR OF THE THIRD BEAM),THIS IS REPRESENTED
C   BY LMC
C
C   SET THE INITIAL NPTS ARRAY
DO 11 I=1,NTP
11  NPTS(I)=I
C**** NTS1 IS THE PREVIOUS VALUES OF THE NUMBER OF TIME SAMPLES(OR INPUT
C   PORTS)
C**** NTS2 IS THE CURRENT VALUE
C**** NFS1 IS THE PREVIOUS VALUE OF THE NUMBER OF FREQUENCY SAMPLES(OR
C   BEAMS)
C**** NFS2 IS THE CURRENT VALUE
C
C
C   SET THE INTAL VALUES OF NTS AND NFS
NTS1=NTP
NFS1=1
DO 20 I=1,NR1
C   MM THE NUMBER OF BLOCKS OF THE CURRENT ROW
C   NN, THE NUMBER OF PORTS IN EACH BLOCK OF THE CURRENT ROW
MM=NRK(I)
NN=NBP(I)
C   SET NTS2 AND NFS2
NTS2=NTS1/MM

```

SHELTON AND HSIAO

```

NFS2=NTP/NTS2
C**** THE ACTUAL REQUIRED PHASE GRADIENT BETWEEN SUCCESSIVE ELEMENT FOR
C THE FIRST BEAM IS
PAG=PI/NFS2
C*** AVAILABLE PHASE GRADIENT FOR THE FIRST BEAM IN EACH BLOCK IS
PSG=PI/NN
KK=0
C*** THE PHASE ANGLE IS STORED ACCORDING TO THE INDEX OF THE LOWER ROW
DO 30 J=1,MM
MODJ=MOD(J,NFS1)
IF(MODJ.EQ.0)MODJ=NFS1
JJ=(J-1)/NFS1+1
PAGG=PAG*(MODJ*2-1)
PASGD=PSG-PAGG
DO 30 K=1,NN
K1=K-1
KK=KK+1
LMC=(MODJ-1)*NTS1+(K-1)*NTS2+JJ
MCLOC=NFTS(LMC)
MC(I,MCLOC)=KK
IF(KK.LF.NTP2)GO TO 31
KKI=NIP+KK+1
PHA(I,KKI)=PHA(I,KKI)
GO TO 30
31 IF(PASGD.GT.0.)GO TO 32
PHA(I,KK)=ABS(PASGD)*(NN-K)
GO TO 30
32 PHA(I,KK)=PASGD*K1
30 CONTINUE
C RECORDING THE FREQUENCY SAMPLE OR BEAM POSITION INTO NFTS ARRAY
NTS1=NTS2
NFS1=NFS2
KK=0
C MNS IS THE NUMBER OF BLOCKS WITHIN EACH GROUP OF FREQUENCY SAMPLES
MNS=MM/NTS1
DO 40 J=1,NFS1
JMOD=MOD(J,MNS)
IF(JMOD.EQ.0)JMOD=MNS
JJ=(J-1)/MNS+1
DO 40 K=1,NTS1
KK=KK+1
40 NFTS(KK)=(K-1)*NFS1+(JMOD-1)*MNS+JJ
20 CONTINUE
RETURN
END

```

NRL REPORT 8188

```

SURROUTINE NTKWPLT(NTP,NR1, NBP,NBK,LH,MC,PHA,XM)
C   NH=1, HALF MATRIX (IN X)
C   NH=0, FULL MATRIX
C   LPT=0 WITH ANGLES
C   LPT=1, WITHOUT ANGLES
C   LPT=2, WITHOUT ANGLES AND HALF (IN Y)
DIMENSION MC(NR1,NTP),PHA(NR1,NTP)
COMMON/2/PLTARRAY(254)
COMMON/3/MCT(512)
DIMENSION NBP(64),NBK(64)
DIMENSION XCM1(512),XCM2(512)
DIMENSION LAP(512)
NH=MOD(LH,10)
LPT=LH/10
PI=3.1415926536
RAC=180./PI
NROW=NR1-1
HLET=.035*2.
WLET=.04*HLET/7.
YM=7.5
IF(XM.GT.0.)GO TO 7
XM=.75*NTP
7   IF(XM.LT.10.)XM=10.
   XM2=XM/2
   YHM=.5
   YSPACE=YM/(NROW+1)
   XS1=XM/(NTP-1)
   NR2=NROW+2
   NN=NR2+
   YR=YM+1.
C   IF NH=1, PLOT HALF THE MATRIX (K-SYMMETRY)
   LLL=0
   IF(NH.NE.1)GO TO 5
C   DETERMINE IF THE NROW IS EVEN OR ODD
   LNH=(NROW+1)/2-NROW/2
C   LNH=1, ODD; LNH=0, EVEN
   NN=(NROW+1)/2+1
   LLL=NH*LNH
5   DO 10 I=1,NR2
   IF(I.GT.NN)GO TO 6
C   FIX THE PORT LOCATION IN EACH ROW
   IF(I.GT.1)GO TO 1
11  DO 11 J=1,NTP
   XCM1(J)=(J-1)*XS1
   Y11=YR
   GO TO 10
1   IF(I.LT.NR2)GO TO 2
   DO 12 J=1,NTP
12  XCM2(J)=(J-1)*XS1
   Y22=YR
   GO TO 3
2   NNBP=NBP(I-1)
   NNBK=NBK(I-1)
   XAK=.8*XM/NNBK
   XBS=.04*XAK
   XLS=XBS/NNBP

```

SHELTON AND HSIAO

```

X1=.1*XM+.1*XBKS
Y1=YR +.5*YBH
Y2=YR -.5*YBH
Y22=Y1
KK=0
DO 13 J=1,NNRK
IF (LPT.GE.2,AND,X1.GT.XM2)GO TO 9
CALL PLOT(X1,Y2,J)
X2=X1+XBKS
CALL PLOT(X1,Y1,2)
CALL PLOT(X2,Y1,2)
CALL PLOT(X2,Y2,2)
IF (LLL.LT.1,OR,I.NE.NN)GO TO 8
CALL DASH(X1,Y2,X2,Y2)
GO TO 9
8 CALL PLOT(X1,Y2,2)
9 X=X1+XBKS/?
Y=YR
XP=.5*XLS+X1
DO 14 K=1,NNRP
KK=KK+1
XCM2(KK)=XP
14 XP=XP+XLS
13 X1=X1+XBK
C DRAW NETWORK CONNECTIONS
3 DO 20 J=1,NTP
X1=XCM1(J)
LMC=MC(I-1,J)
X2=XCM2(LMC)
XI=X1
YI=Y11
IF (LPT.LT.2,OR,X1.LT.XM2)GO TO 18
IF (X2.GT.XM2)GO TO 20
XI=XM
18 YI=YEP(X2,Y22,X1,Y11,XM2)+Y22
XI=X2
Y2T=Y22
IF (LPT.LT.2,OR,X2.LT.XM2)GO TO 17
XI=XM2
17 Y2T=Y11-YEP(X1,Y11,X2,Y22,XM2)
YI1=0.
IF (I.EQ.2)YI1=.1
IF (LPT.GE.2,AND,X1.GT.XM2)YI1=0.
CALL PLOT(XI,YI1+YI1,3)
IF (I.GT.2)GO TO 4
IF (LPT.GE.2,AND,X1.GT.XM2)GO TO 4
CALL PLOT(XI,YI1,2)
4 CALL PLOT(XI,Y2T,2)
IF (I.NE.NRP)GO TO 19
IF (X2.GE.XM2,AND,LPT.EQ.2)GO TO 19
IF (I.EQ.NRP,AND,X2.LT.XM2)CALL PLOT(X2,Y22-.1,2)
19 CALL PLOT(X2,Y22-.1,2)
IF (LPT.GT.0)GO TO 20
IF (LPT.GT.0)GO TO 20
A=ABS(PHA(I-1,LMC))*RAC
IF (A.LE..001)GO TO 20

```

```

IF(I,NF,NR2)GO TO 15
Y222=Y22+YSPACE-.5*YBM+2.*HLET
X=X1-3.*WLET
GO TO 16
15 Y222=Y22-?.*HLET
X=X2-3.*WLET
16 CALL NUMBER(X ,Y222,HLET,A,0.,.4HF6.2)
20 CONTINUE
C RESET XCMi ARRAY
DO 21 J=1,NTP
21 XCM1(J)=XCM2(J)
Y11=Y2
10 YR=YR-YSPACE
IF(LPT.GE.2)CALL DASH(XM2,YM+1.1,XM2,Y22-.1)
RETURN
6 Y=YR+YSPACE/?
XMM=XM
IF(LPT.GE.2)XMM=XM2
CALL DASH(0.,Y,XMM,Y)
DO 31 J=1,NTP
31 LAP(J)=0
Z=Y-2.*HLET
NTPK=NTP
IF(LPT.GE.2)NTPK=NTP/2
DO 30 J=1,NTPK
IF(LAP(J).GT.0)GO TO 30
X1=XCM1(J)
JJ=MCT(J)
LAP(JJ)=1
X2=XCM1(JJ)
X=X1
XT=X2
YT=Y2
IF(LPT.LT.2.OR.X2.LF.XM2)GO TO 32
XT=XM2
YT=YEP(X,Y,X2,Y2,XM2)+Y
32 CALL PLOT(X1,Y2,J)
CALL PLOT(X ,Y,2)
CALL PLOT(XT,YT,2)
IF(LPT.GT.0)GO TO 30
IF(LNH.GT.0)GO TO 30
LMC=MC(NN,J)
A=ARS(PHA(NN+LMC))*RAC
X=X-3.*WLET
CALL NUMBER(X,Z,HLET,A,0.,.4HF6.2)
30 CONTINUE
IF(LPT.GE.2)CALL DASH(XM2,YM+1.1,XM2,Y)
RETURN
END

```

SHELTON AND HSIAO

```

SUBROUTINE DASH(X1,Y1,X2,Y2)
C THIS SUBROUTINE DRAWS A DASHED LINE FROM A POINT X1, Y1 TO A POINT
C X2, Y2
X12=X2-X1
Y12=Y2-Y1
D=SQRT(X12**2+Y12**2)
SD=.1
2 NN=D/SD
DD=D-NN*SD
IF (ABS(DD).LE..001) GO TO 1
SD=SD+DD/NN
GO TO 2
1 XINC=SD*X12/D
YINC=SD*Y12/D
X=X1
Y=Y1
DO 10 I=1,NN,2
CALL PLOT(X,Y,3)
X=X+XINC
Y=Y+YINC
CALL PLOT(X,Y,2)
X=X+XINC
Y=Y+YINC
10 CONTINUE
RETURN
END

```

NRL REPORT 8188

```

SUBROUTINE HLFMTX(NTP,NR1,NBP,NRK,MC,PHA)
DIMENSION NBP(64),NRK(64)
DIMENSION MC(NR1,NTP),PHA(NR1,NTP)
COMMON/3/MCT(512)
DIMENSION ANG(512),ATEMP(512)
NN=NR1/2
LL=(NR1+1)/2-NN
C LL=1 NUMBER OF ROWS IS EVEN
C LL=0 NUMBER OF ROWS IS ODD
CALL PHASIJM(NR1,NTP,NBP,MC,PHA,ANG)
DO 10 I=1,NTP
  II=I
  DO 11 J=1,NR1
    KK=MC(J,I)
    IF(J.EQ.NN)KKP=KK
    II=KK
  11 CONTINUE
  C FIND THE JOINT POINT THEN STORE IN MCT ARRAY
  DO 12 J=1,NN
    KKS=MC(J,II)
  12 KK=KKS
    MCT(KKP)=KKS
  C AVERAGE THE PHASE ANGLES FOR SYMMETRICAL MATRIX
  DO 13 J=1,NN
    JJ=NR1-J+1
    IMC=MC(J,I)
  13 AVG=(PHA(J,IMC)+PHA(JJ,I))/2.
  10 PHA(J,IMC)=PHA(JJ,I)=AVG
  C CONTINUE
  C CORRECT PHASE ANGLE OF THE MIDDLE ROW WHEN THE NUMBER OF ROWS IS
  C EVEN
  IF(LL.EQ.0)GO TO 1
  N1=NN+1
  DO 20 I=1,NTP
    II=MC(N1,I)
    IN=MC(N1,MCT(I))
    ATEMP(II)=PHA(N,II)
    IF(PH(N1,IN).GT.ATEMP(II))ATEMP(II)=PHA(N1,IN)
  20 CONTINUE
  C CORRECT THE PHASE ANGLE BY ADDING THE SAME EXTRA PHASE TO EACH
  C PORT IN A BLOCK
  NMP=NBP(N1)
  NMB=NRK(N1)
  DO 21 I=1,NMP
    IMB=(I-1)*NMP
    AA=0.
    DO 22 J=1,NMP
      KK=IMB+J
      A=ATEMP(KK)-PHA(N1,KK)
      IF(A.GT.AA)AA=A
    22 CONTINUE
    IF(AA.EQ.0.)GO TO 21
    DO 23 J=1,NMP
      KK=IMB+J
      PHA(N1,KK)=PHA(N1,KK)+AA
    23 CONTINUE
  21

```

SHELTON AND HSIAO

```

RETURN
C CORRECT THE PHASE ANGLES FOR THE CASE WHEN THE NUMBER OF ROWS IS
C ODD
1 CALL PHASUM(NR1,NTP,NBP,MC,PHA,ATEMP)
DO 30 I=1,NTP
AA=ANG(I)-ATEMP(I)
JJ=MC(I,I)
30 PHA(1,JJ)=PHA(NR1,I)+AA
RETURN
END

```

```

SUBROUTINE PHASUM(NR1,NTP,NBP,MC,PHA,AS)
DIMENSION NBP(64)
DIMENSION MC(NR1,NTP),PHA(NR1,NTP),AS(NTP)
DIMENSION LAP(2,512),A(512)
C SET THE PHASE SHIFT OF THE BOTTOM ROW
NROW=NR1-1
NN=NBP(NROW)
DO 1 J=1,NN
LAP(2,J)=J
1 AS(J)=PHA(1,1)
KK=NN
DO 10 I=1,NROW
II=NROW-I
I1=II+1
NN=NBP(II)
IF(II.LE.0)NN=1
DO 12 J=1,NTP
LAP(1,J)=LAP(2,J)
12 A(J)=AS(J)
KN=
DO 20 L=1,KN
LL=LAP(1,L)
DO 21 N=1,NTP
IF(MC(II,N).NE.LL)GO TO 21
JJ=N
GO TO 22
21 CONTINUE
22 NMD=MOD(JJ,NN)
IF(NMD.EQ.0)NMD=NN
DO 30 K=1,NN
IND=JJ-NMD+K
IF(NN.EQ.1)IND=JJ
KN=KN+1
LAP(2,KN)=IND
30 AS(IN)=A(LL)+PHA(II,LL)
20 CONTINUE
KK=KN
10 CONTINUE
RETURN
END

```

NRL REPORT 8188

```

SUBROUTINE PRTOUT(NTP,NR1,MC,PHA,LP)
DIMENSION MC(NR1,NTP),PHA(NR1,NTP)
DIMENSION PANG(5 2)
PI=3.1415926536
RAC=180./PI
IF(LP.GT.0) GO TO 1
PRINT 102
102 FORMAT(//,10X,*CONVENTIONAL MATRIX CONNECTION AND PHASE*,//)
GO TO 2
1 PRINT 107
107 FORMAT(//,10X,*SYMMETRICAL MATRIX PHASE ANGLES*,//)
GO TO 3
2 DO 10 I=1,NR1
PRINT 103,I
103 FORMAT(//,20X,*ROW=*,I5,//)
10 PRINT 104,(MC(I,J),J=1,NTP)
104 FORMAT(1H , 10X,I0I5)
PRINT 105
105 FORMAT(//,10X,*CONNECTION PHASE ANGLES*,//)
3 DO 20 I=1,NR1
DO 21 J=1,NTP
LMC=J
IF(I.EQ.NR1)LMC=MC(I,J)
21 PANG(J)=PHA(I,LMC)*RAC
PRINT 103,I
20 PRINT 106,(PANG(J),J=1,NTP)
106 FORMAT(1H , 10X,5F10.4)
RETURN
END

```

```

FUNCTION YEP(X1,Y1,X2,Y2,XM)
XR=(XM-X1)/(X2-XM)
YEP=XR*ABS(Y1-Y2)/(1.+XR)
RETURN
END

```