

AD-A054 025

ARMY MATERIALS AND MECHANICS RESEARCH CENTER WATERTO--ETC F/G 13/5  
EFFECT OF SPOT AND STUD WELDING ON ESR 4340 STEEL ARMOR.(U)  
FEB 78 D C BUFFUM  
AMMRC-TR-78-5

UNCLASSIFIED

NL

| OF |  
AD  
A054 025

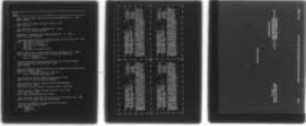

END  
DATE  
FILMED  
6-78  
DDC

FOR FURTHER TRAN

AMMRC TR 78-5

AD

12

AD A 054025

# EFFECT OF SPOT AND STUD WELDING ON ESR 4340 STEEL ARMOR

DDC FILE COPY

DONALD C. BUFFUM  
PROCESS DEVELOPMENT DIVISION

February 1978

Approved for public release; distribution unlimited.

ARMY MATERIALS AND MECHANICS RESEARCH CENTER  
Watertown, Massachusetts 02172

DDC  
MAY 19 1978  
E

The findings in this report are not to be construed as an official Department of the Army position, unless so designated by other authorized documents.

Mention of any trade names or manufacturers in this report shall not be construed as advertising nor as an official indorsement or approval of such products or companies by the United States Government.

**DISPOSITION INSTRUCTIONS**

Destroy this report when it is no longer needed.  
Do not return it to the originator.

UNCLASSIFIED

SECURITY CLASSIFICATION OF THIS PAGE (When Data Entered)

REPORT DOCUMENTATION PAGE		READ INSTRUCTIONS BEFORE COMPLETING FORM
1. REPORT NUMBER AMMRC-TR-78-5	2. GOVT ACCESSION NO.	3. RECIPIENT'S CATALOG NUMBER
4. TITLE (and Subtitle) EFFECT OF SPOT AND STUD WELDING ON ESR 4340 STEEL ARMOR.	5. TYPE OF REPORT & PERIOD COVERED Final Report.	
7. AUTHOR(s) Donald C./Buffum	8. CONTRACT OR GRANT NUMBER(s)	
9. PERFORMING ORGANIZATION NAME AND ADDRESS Army Materials and Mechanics Research Center Watertown, Massachusetts 02172 DRXMR-ER	10. PROGRAM ELEMENT, PROJECT, TASK AREA & WORK NUMBER D/A Project: 1T162105AH84 AMCMC Code: 612105.11.H8400 Agency Accession: DA/OE4807	
11. CONTROLLING OFFICE NAME AND ADDRESS U. S. Army Materiel Development and Readiness Command, Alexandria, Virginia 22333	12. REPORT DATE Feb 1978	13. NUMBER OF PAGES 8
14. MONITORING AGENCY NAME & ADDRESS (if different from Controlling Office)	15. SECURITY CLASS. (of this report) Unclassified	
16. DISTRIBUTION STATEMENT (of this Report)  Approved for public release; distribution unlimited.		
17. DISTRIBUTION STATEMENT (of the abstract entered in Block 20, if different from Report)		
18. SUPPLEMENTARY NOTES		
19. KEY WORDS (Continue on reverse side if necessary and identify by block number)  Spot welding                      High strength steel Stud welding                      Joining Armor (steel)                      Electroslag-remelted steel		
20. ABSTRACT (Continue on reverse side if necessary and identify by block number)  <p style="text-align: center;">(SEE REVERSE SIDE)</p> <p style="text-align: right; font-size: 2em;">403 105      Jm</p>		

Block No. 20

ABSTRACT

The object of this project was to determine the effect of spot and stud welding on heat-treated ESR armor. It was noted that a hard layer of untempered martensite formed in the base metal below the spot and stud welds. Variations in welding technique did not remove or reduce this hard layer. The hard layer caused the welded appendage to be separated from the plate by the shock wave produced by ballistic impact. Heat treatment of the stud welds reduced the hardness of the hard layer without significant effect on the base plate. This reduced the tendency for the appendage to spall off as a result of the ballistic shock wave.

ACCESSION for	
NTIS	White Section <input checked="" type="checkbox"/>
DOC	Buff Section <input type="checkbox"/>
UNANNOUNCED	<input type="checkbox"/>
JUSTIFICATION.....	
BY.....	
DISTRIBUTION/AVAILABILITY CODES	
Dist. AVAIL. and/or SPECIAL	
A	

## INTRODUCTION

During field repair or while making additions on armored vehicles it is necessary to attach items to steel armor in its final heat-treated condition. Stud and spot welding are two of the welding processes that are used in making such attachments.

Both of these processes are fusion welding techniques involving concentrated high temperatures that cause localized melting and heat treatment in the area of the weldment. These inherent characteristics cause localized microstructural changes, residual stresses, and chemical inhomogeneity. The magnitude of these items depend on many variables, including the composition of materials and the size and geometry of the components. Generally, the evaluation of weldments of these types does not include the effects that the welding will have on the properties of the parent metal.

## OBJECTIVE

The objective of the project is to determine the effect that stud and spot welding have on the properties of electroslag-remelted (ESR) 4340 steel armor.

## MATERIALS

The armor used in this program was commercially produced ESR 4340 steel in thicknesses of 3/8 inch and 1/2 inch. Studs were of AISI 1022 and 304 stainless steels. For each composition, 1/4-inch-diameter and 3/8-inch-diameter studs with solid flux were used. For spot welds, AISI 1015 steel sheet 0.058 inch thick and 304 stainless steel sheet 0.075 inch thick were used. Composition of the materials used is given in Table 1.

The studs and the sheet were used in the as-received condition. The 4340 armor plate was heat treated as follows.

The 3/8-inch-thick plate was austenitized at 1575 F for 1 hour, oil quenched, and tempered at 300 F for 2-1/2 hours, and air cooled. The 1/2-inch-thick plate was austenitized at 1575 F for 1 hour, oil quenched, and tempered at 375 F for 3 hours, and air cooled. Both plates had a Rockwell C hardness of 55 (Vickers hardness 600).

Table 1. COMPOSITION OF MATERIALS

Materials	Elements (Weight Percent)							
	C	Mn	P	S	Si	Ni	Cr	Mo
ESR 4340	0.38	0.74	0.007	0.005	0.22	1.90	0.79	0.25
AISI 1015	0.15-0.18	0.30-0.60	0.040 max	0.050 max				
AISI 1022	0.18-0.23	0.7 -1.0	0.040 max	0.050 max				
304 S.S.	0.08 max	2.0 max	-	-	1.0 max	8.0-12.0	18.0-20.0	

## WELDING EQUIPMENT

The spot welds were made with an automatic three-phase welder which had a maximum secondary amperage of 70,000 amps. The following controls were used in making the weldments: squeeze time, weld time, hold time, heating cycle, cooling cycle, load force, and weld phase shift which is a percentage of the maximum current.

The stud welds were made using a hand-held gun with a special fixture to assure perpendicular and reproducible weldments. The amperage and length of contact time could be set at any predetermined value within the limits of the equipment. The amperage limits were 0 to 600 amperes and the time limits were 0.2 to 1.4 seconds.

## PROCEDURE

The spot welds were initially made with a single impulse. The hold time was 0.6 second; the squeeze time 0.3 second; the heat time varied from 1 to 6 cycles; the weld phase shift was set at four different levels: 70, 80, 90, and 100; and the load force was 1900 pounds. A shear test was used to evaluate the weldments.

Using these parameters, a series of 1-inch square pieces of sheet were spot welded to the armor plate, with a space of 3 inches between centers. The hold time, squeeze time, and load force were the same as above. Five and six heat cycles were used, with weld phase shift settings of 70, 80, and 90.

For ballistic tests .30 caliber AP projectiles were fired at the 3/8-inch plate, and .50 caliber AP projectiles were fired at the 1/2-inch plate, both at 0° obliquity. The velocity of the projectiles was varied to obtain a  $V_{50}$  value, which is the average of the highest velocity that does not penetrate and the lowest velocity that does.

## RESULTS AND DISCUSSION

In the ballistic tests of the above plates, half the 1-inch squares were separated from the armor plate by the shock wave generated from projectiles fired at other squares. Examination of the spot welds showed excessive weld penetration, some fine cracks in the weld, and small weld nuggets. To improve the weldments, the top electrode was changed from 1/4-inch diameter to one with a 5/8-inch diameter and a 4-inch diameter curvature, and the bottom electrode was changed to a flat one with a 5/8-inch diameter. Although this change did improve the nugget size, it did not improve penetration or reduce the cracking tendency.

A multipulse spot welding technique with the electrodes described above was also evaluated. In this technique the current is applied in a series of on-off pulses which allow the heat to penetrate further into the armor plate. The variables used in making the multipulse spot welds were as follows:

Squeeze Time	0.3 second
Weld Time	2.25 seconds
Hold Time	3.00 seconds
Heat	5 cycles
Cool	3 cycles
Load Force	1900 pounds
Weld Phase Shift	
3/8-inch plate and low carbon steel	68
3/8-inch plate and stainless steel	64
1/2-inch plate and low carbon steel	68
1/2-inch plate and stainless steel	65

This technique produced sounder weldments which fractured at a shear load of 5100 to 5600 pounds as compared to 3600 to 4600 pounds for the single pulse weldments. The ballistic tests on the 3/8-inch plates gave  $V_{50}$  values of 2044 ft/sec to 1857 ft/sec for welded plate as compared to 1957 ft/sec for the unwelded plate. For the 1/2-inch plate the welded values were 2443 ft/sec to 2299 ft/sec as compared to 2433 ft/sec for the unwelded plate.

Although these values were in an acceptable range, metallographic examination of similar welds showed porosity in the 3/8-inch plate (Figure 1). In an attempt to reduce the porosity, weldments were made on the 1/2-inch plate as well as the 3/8-inch plate using a load force of 2200 pounds. With the increased load force it was found that a lower weld phase shift would be required to prevent expulsion. On the 3/8-inch plate the weld phase shift setting was in the range of 52 to 55 and on the 1/2-inch plate the weld phase shift setting was in the range of 62 to 68.

During the ballistic testing 75% of the squares separated from the plates from the first round fired at each plate. Similar weldments were made for metallographic and hardness studies from which it was observed that a narrow band existed below the weld zone which was extremely hard (Vickers hardness 650 to 770). Several attempts were made to reduce the magnitude of the hardness variation. In these attempts a weld decay cycle, various multipulse heat-cool cycle combinations and weld phase shift variations were used, none of which produced satisfactory weldments without the high hardness layer.



Figure 1. Porosity in 3/8-inch base metal. Mag. 4X

For the stud welds the bend test mentioned in the American Welding Society's publication, Recommended Practices for Stud Welding (AWS Specification C5.5-74), was used for evaluation of the weldments. This test calls for bending the stud 15° with a special tool and observing whether cracking occurs. For each combination of stud size, stud composition, and armor plate thickness, several variations of time and current were tried. The following combinations produced satisfactory welds that repeatedly passed the bend test.

Steel Studs	On ESR Plate	
	3/8 inch thick	1/2 inch thick
3/8-inch low carbon	0.4 sec at 600 A or 0.5 sec at 550 A	0.4 sec at 600 A or 0.5 sec at 550 A
3/8-inch 304 stainless	0.5 sec at 450 A	0.6 sec at 350 A or 0.4 sec at 500 A
1/4-inch low carbon	0.2 sec at 500 A or 0.3 sec at 450 A	0.2 sec at 500 A or 0.3 sec at 450 A
1/4-inch 304 stainless	0.25 sec at 350 A	0.3 sec at 300 A

Although stud welds made with the above settings passed the bend test, a large percentage of them were separated from the plate by the ballistic shock wave during ballistic testing. The ballistic tests were the same as those used for spot-welded plates. Metallographic and hardness surveys showed that a narrow hard layer of material was present just below the stud. This is similar to that found in the spot weldments. Figure 2 shows the narrow band of high hardness material that appears between the stud or platelet and the base material.

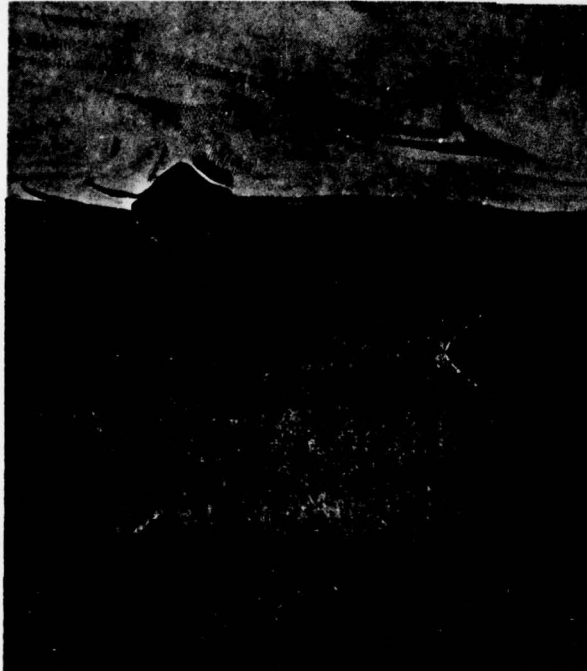

Figure 2. Hard layer of untempered martensite between stud or platelet and base material. Mag. 33X

On the stud weldments, since the variations that could be used to make the welds were limited, an extensive effort was made to soften the layer by means of localized heat treatment. The first attempt at localized heat treatment was to pass a current from the welding power source through the stud into the plate. Several types of electrical contacts to the stud were used. These included spring clamps, cylinders held in place with set screws, two half-cylinders clamped around the stud, and cylinders that were press fitted to the stud. This form of heat treating did soften the layer at the base of the stud, however, because of poor electrical contact between the fixture and the stud, it was not possible to obtain reproducible temperatures at the point of interest.

Induction heating was also tried, using a small coil around the base of the stud. However, in order to get sufficient heat to the base of the stud it was necessary to heat the stud excessively. To alleviate this problem, a small hollow cylinder of graphite with the internal diameter 1/16 inch larger than the diameter of the stud, the wall thickness about 1/16 inch, and the height 5/16 inch, was placed around the stud. This was insulated from the three-turn induction coil by a 1/8-inch-thick wall ceramic sleeve. Using this setup (schematic shown in Figure 3) it was possible to heat the specimens up to at least 800 F in 1 to 2 minutes. It was also possible to reproduce the heat treatments within plus or minus 20 F of the desired temperature basing the heat treating on the time of heating.

The initial heat treating temperature selected was 400 F, slightly above the tempering temperature of the 4340 plate. Metallographic and hardness surveys of specimens so treated indicated no change in peak hardness, no variation of hardness differential, and the continued presence of a hard layer below the welded stud.

The next series of specimens were heated to 800 F and air cooled. These specimens showed a decrease in hardness within the hard layer with little or no reduction in hardness of the stud or base metal. Figure 4 shows a typical hardness survey of the as-welded and the welded-and-heat-treated stud weldments. Ballistic tests of specimens heat treated to 800 F showed a great reduction in the number of studs separated from the plate by ballistic shock. The decrease

Figure 3. Schematic cross-sectional view showing induction heating setup.

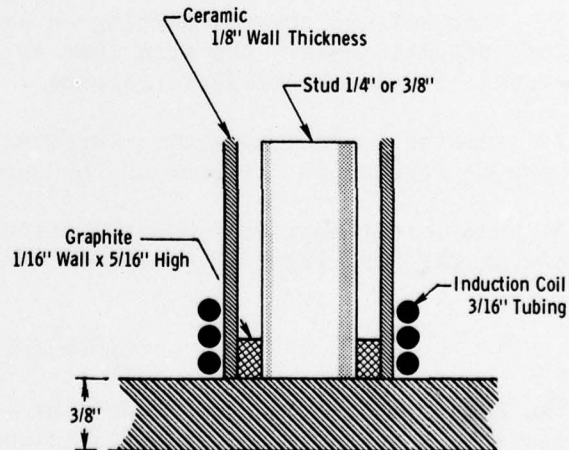

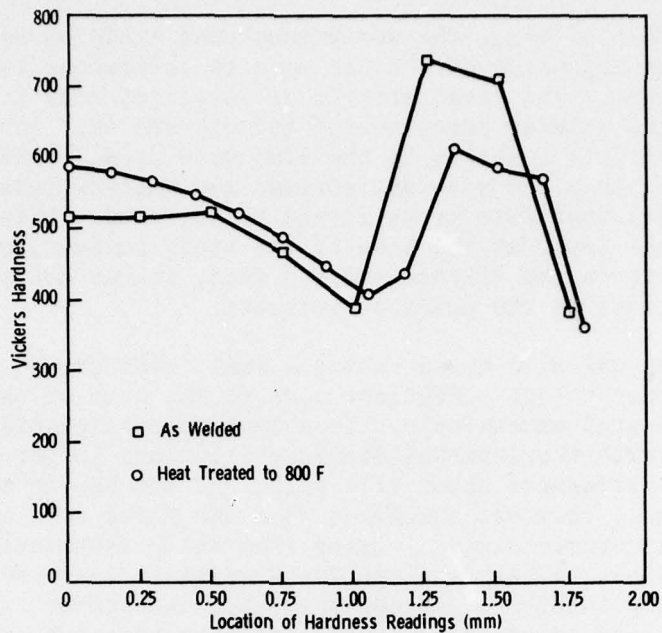

Figure 4. Typical hardness surveys on as-welded and welded plus heat-treated stud welds.

was from between 50% to 75% of the as-welded studs to less than 10% for the welded-and-heat-treated studs. Metallographic examination of the 10% that separated indicated that there was high probability that welding flaws caused the failure, not the hard layer.

The experimental work on this program was performed using an electroslag-remelted steel. However, it is believed that similar results would be obtained on any steel alloy whose chemical composition was such as to produce hard microstructures at the cooling rates involved.

### CONCLUSIONS

1. Spot welding or stud welding on armor such as ESR 4340 produces a hard layer of material beneath the weld that is brittle and subject to failure by shock waves produced by ballistic impact.
2. Welding variations within the range of the equipment used could not eliminate or reduce the hardness of the hard layer in spot or stud weldments.
3. Heat treatments were devised for the stud welds that would reduce the hardness of the hard layer with minimal effect on the base material.

### ACKNOWLEDGMENT

The author wishes to acknowledge the innovative efforts of Mr. Joseph Iannelle in his attempts to produce jigs and fixtures for the suggested techniques for heat treating the hard layer in the weldments.

## DISTRIBUTION LIST

No. of Copies	To
1	Office of the Director, Defense Research and Engineering, The Pentagon, Washington, D.C. 20301
12	Commander, Defense Documentation Center, Cameron Station, Building 5, 5010 Duke Street, Alexandria, Virginia 22314
1	Advanced Research Projects Agency, The Pentagon, Washington, D.C. 20315
	Metals and Ceramics Information Center, Battelle Columbus Laboratories, 505 King Avenue, Columbus, Ohio 43201
2	ATTN: Mr. Daniel Maykuth
	Deputy Chief of Staff for Research, Development, and Acquisition, Headquarters, Department of the Army, Washington, D.C. 20310
2	ATTN: DAMA-ARZ
1	Dr. Bernard R. Stein
	Commander, U.S. Army Materiel Development and Readiness Command, 5001 Eisenhower Avenue, Alexandria, Virginia 22333
1	ATTN: DRCDE-DE, Development Division
1	DRCDE-RS, Research Division
1	DRCDE-RS, Scientific Deputy
1	DRCLDC, Mr. R. Zentner
	Commander, U.S. Army Aviation Research and Development Command, P.O. Box 209, Main Office, St. Louis, Missouri 63166
1	ATTN: DRSAB-LEP, Mr. J. M. Thorp
1	DRSAV-ER, Dr. I. Peterson
	Commander, U.S. Army Missile Research and Development Command, Redstone Arsenal, Alabama 35809
1	ATTN: DRDMI-IE, Mr. J. E. Kirshtein
1	DRDMI-R, Mr. John L. McDaniel
1	DRDMI-TB, Redstone Scientific Information Center
1	Chief Scientist, Dr. W. W. Carter
1	Directorate of R&D
1	Dr. B. Steverding
	Commander, U.S. Army Troop Support and Aviation Materiel Readiness Command, 4300 Goodfellow Boulevard, St. Louis, Missouri 63120
1	ATTN: DRDME, Mr. J. Murphy
	Commander, U.S. Army Armament Research and Development Command, Dover, New Jersey 07801
1	ATTN: DRDAR-SCM, J. D. Corrie
2	Technical Library

---

No. of  
Copies

To

---

Commander, U.S. Army Tank-Automotive Research and Development Command,  
Warren, Michigan 48090  
1 ATTN: DRDTA-PPS, Mr. David Siegel  
1 DRDTA-RCM.1, Mr. Edward Moritz  
1 DRDTA-RCM.1, Mr. Donald Phelps

Commander, Aberdeen Proving Ground, Maryland 21005  
3 ATTN: Technical Library, Building 313

Commander, U.S. Army Foreign Science and Technology Center,  
220 7th Street, N.E., Charlottesville, Virginia 22901  
1 ATTN: DRXST-MT1

Commander, Frankford Arsenal, Philadelphia, Pennsylvania 19137  
1 ATTN: Pitman-Dunn Institute of Research

Commander, Picatinny Arsenal, Dover, New Jersey 07801  
1 ATTN: Feltman Research Laboratories

Commander, Rock Island Arsenal, Rock Island, Illinois 61201  
1 ATTN: DRSAR-LEP-L

Director, Eustis Directorate, U.S. Army Air Mobility Research and  
Development Laboratory, Fort Eustis, Virginia 23604  
1 ATTN: Mr. J. Robinson, DAVDL-E-MOS (AVRADCOM)

Commander, U.S. Army Ballistic Research Laboratories, Aberdeen Proving  
Ground, Maryland 21005  
1 ATTN: Dr. D. Eichelberger

Director, U.S. Army Materiel System Analysis Activity, Aberdeen Proving  
Ground, Maryland 21005  
1 ATTN: DRXRD-D

Commander, U.S. Army Electronics Research and Development Command,  
225 South 18th Street, Philadelphia, Pennsylvania 19103  
1 ATTN: DRSEL-PP/P/IED-2, Mr. Wesley Karg

Commander, U.S. Army Mobility Equipment Research and Development Command,  
Fort Belvoir, Virginia 22060  
2 ATTN: Technical Documents Center, Building 315

Commander, U.S. Army Production Equipment Agency, Manufacturing Technology  
Branch, Rock Island Arsenal, Illinois 61202  
1 ATTN: Library

Commander, Watervliet Arsenal, Watervliet, New York 12189  
1 ATTN: DRDAR-R  
1 Dr. Robert Weigle

1 Chief, Bureau of Naval Weapons, Department of the Navy, Room 2225,  
Munitions Building, Washington, D.C. 20390

No. of  
Copies

To

---

Chief, Bureau of Ships, Department of the Navy, Washington, D.C. 20315  
1 ATTN: Code 341

Chief of Naval Research, Arlington, Virginia 22217  
1 ATTN: Code 471

Naval Research Laboratory, Washington, D.C. 20375  
2 ATTN: Dr. G. R. Yoder, Code 6384

Headquarters, USAF/RDPI, The Pentagon, Washington, D.C. 20330  
1 ATTN: Major Donald Sponberg

Air Force Materials Laboratory, Wright-Patterson Air Force Base, Ohio 45433  
1 ATTN: AFML (MATB), Mr. George Glenn  
2 AFML (MXE), E. Morrissey  
1 AFML (LLP), D. M. Forney, Jr.  
1 AFML (LC)  
1 AFML (MBC), Mr. Stanley Schulman

National Aeronautics and Space Administration, Washington, D.C. 20546  
1 ATTN: AFSS-AD, Office of Scientific and Technical Information  
1 Mr. B. G. Achhammer  
1 Mr. G. C. Deutsch, Code RW

National Aeronautics and Space Administration, Lewis Research Center,  
21000 Brookpark Road, Cleveland, Ohio 44135  
1 ATTN: Library

National Aeronautics and Space Administration, Marshall Space Flight Center,  
Huntsville, Alabama 35812  
1 ATTN: R. J. Schwinghamer, EH01, Dir., M&P Lab  
1 Mr. W. A. Wilson, EH41, Bldg. 4612

Albany Metallurgy Research Center, Albany, Oregon 97321  
1 ATTN: Mr. A. H. Roberson, Research Director

Defense Materials Service, General Services Administration,  
Washington, D.C. 20405  
1 ATTN: Mr. Clarence A. Fredell, Director, Technical R&D Staff

General Dynamics, Convair Aerospace Division, P.O. Box 748,  
Fort Worth, Texas 76101  
1 ATTN: Mfg. Engineering Technical Library

Cabot Corporation, Machinery Division, P.O. Box 1101, Pampa, Texas 79065  
1 ATTN: W. L. Hallerberg, Director of Metallurgy

Director, Army Materials and Mechanics Research Center,  
Watertown, Massachusetts 02172  
2 ATTN: DRXMR-PL  
1 DRXMR-AG-MD  
1 Author

AD  
Army Materials and Mechanics Research Center,  
Watertown, Massachusetts 02172  
EFFECT OF SPOT AND STUD WELDING ON ESR  
4340 STEEL ARMOR - Donald C. Buffum

UNCLASSIFIED  
UNLIMITED DISTRIBUTION

Key Words  
Spot welding  
Stud welding  
Armor (steel)

Technical Report AMMRC TR 78-5, February 1978, 8 pp -  
illus-tables, D/A Project 11162105AH84,  
AMCMS Code 612105.11.H8400

The object of this project was to determine the effect of spot and stud welding on heat-treated ESR armor. It was noted that a hard layer of untempered martensite formed in the base metal below the spot and stud welds. Variations in welding technique did not remove or reduce this hard layer. The hard layer caused the welded appendage to be separated from the plate by the shock wave produced by ballistic impact. Heat treatment of the stud welds reduced the hardness of the hard layer without significant effect on the base plate. This reduced the tendency for the appendage to spall off as a result of the ballistic shock wave.

AD  
Army Materials and Mechanics Research Center,  
Watertown, Massachusetts 02172  
EFFECT OF SPOT AND STUD WELDING ON ESR  
4340 STEEL ARMOR - Donald C. Buffum

UNCLASSIFIED  
UNLIMITED DISTRIBUTION

Key Words  
Spot welding  
Stud welding  
Armor (steel)

Technical Report AMMRC TR 78-5, February 1978, 8 pp -  
illus-tables, D/A Project 11162105AH84,  
AMCMS Code 612105.11.H8400

The object of this project was to determine the effect of spot and stud welding on heat-treated ESR armor. It was noted that a hard layer of untempered martensite formed in the base metal below the spot and stud welds. Variations in welding technique did not remove or reduce this hard layer. The hard layer caused the welded appendage to be separated from the plate by the shock wave produced by ballistic impact. Heat treatment of the stud welds reduced the hardness of the hard layer without significant effect on the base plate. This reduced the tendency for the appendage to spall off as a result of the ballistic shock wave.

AD  
Army Materials and Mechanics Research Center,  
Watertown, Massachusetts 02172  
EFFECT OF SPOT AND STUD WELDING ON ESR  
4340 STEEL ARMOR - Donald C. Buffum

UNCLASSIFIED  
UNLIMITED DISTRIBUTION

Key Words  
Spot welding  
Stud welding  
Armor (steel)

Technical Report AMMRC TR 78-5, February 1978, 8 pp -  
illus-tables, D/A Project 11162105AH84,  
AMCMS Code 612105.11.H8400

The object of this project was to determine the effect of spot and stud welding on heat-treated ESR armor. It was noted that a hard layer of untempered martensite formed in the base metal below the spot and stud welds. Variations in welding technique did not remove or reduce this hard layer. The hard layer caused the welded appendage to be separated from the plate by the shock wave produced by ballistic impact. Heat treatment of the stud welds reduced the hardness of the hard layer without significant effect on the base plate. This reduced the tendency for the appendage to spall off as a result of the ballistic shock wave.

AD  
Army Materials and Mechanics Research Center,  
Watertown, Massachusetts 02172  
EFFECT OF SPOT AND STUD WELDING ON ESR  
4340 STEEL ARMOR - Donald C. Buffum

UNCLASSIFIED  
UNLIMITED DISTRIBUTION

Key Words  
Spot welding  
Stud welding  
Armor (steel)

Technical Report AMMRC TR 78-5, February 1978, 8 pp -  
illus-tables, D/A Project 11162105AH84,  
AMCMS Code 612105.11.H8400

The object of this project was to determine the effect of spot and stud welding on heat-treated ESR armor. It was noted that a hard layer of untempered martensite formed in the base metal below the spot and stud welds. Variations in welding technique did not remove or reduce this hard layer. The hard layer caused the welded appendage to be separated from the plate by the shock wave produced by ballistic impact. Heat treatment of the stud welds reduced the hardness of the hard layer without significant effect on the base plate. This reduced the tendency for the appendage to spall off as a result of the ballistic shock wave.

AMMRC TR 78-5

EFFECT OF SPOT AND STUD WELDING ON ESR 4340 STEEL ARMOR

Buttun

DEPARTMENT OF THE ARMY  
ARMY MATERIALS AND MECHANICS RESEARCH CENTER  
Watertown, Massachusetts 02172  
OFFICIAL BUSINESS

POSTAGE AND FEES PAID  
DEPARTMENT OF THE ARMY  
DOD 314

THIRD CLASS MAIL