

AD-A054 063

NAVAL WEAPONS HANDLING CENTER COLTS NECK N J
PACKAGING FOR 76 MM OTTO MELARA AMMUNITION. PHASE I, (U)
SEP 77 D D MACLEOD

F/G 19/1

UNCLASSIFIED

NWHC-7786

NL

1 OF 2
ADA
054063

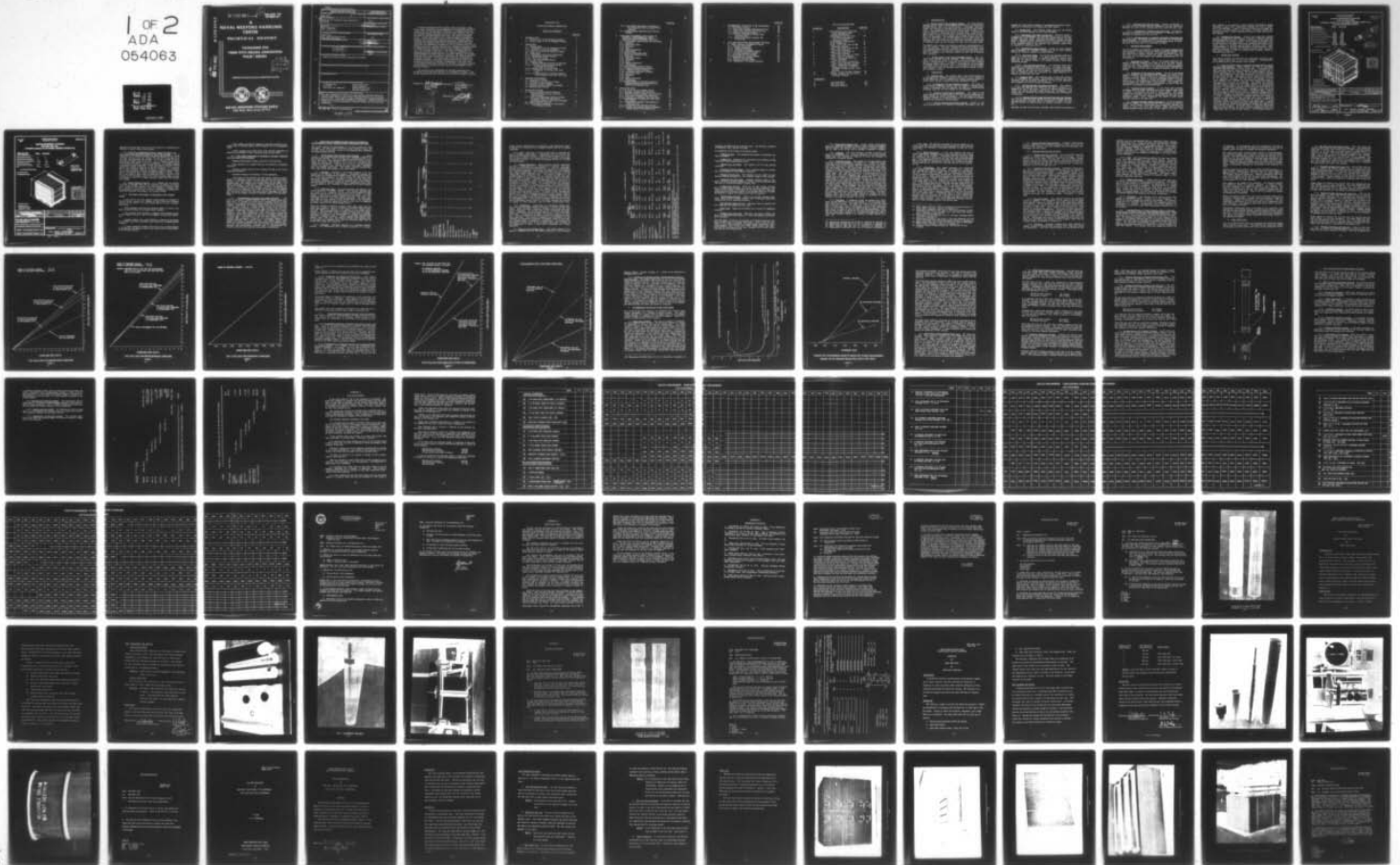

AH
12

FOR FURTHER TRAN *IT...*

NWHC REPORT 7786
SEPTEMBER 1977

AD A 054063

A
NAVAL WEAPONS HANDLING
CENTER
TECHNICAL REPORT

PACKAGING FOR
76MM OTTO MELARA AMMUNITION
PHASE 1 REPORT

... INU.
DDC FILE COPY

DDC
RECEIVED
MAY 24 1978
RECEIVED
A

APPROVED FOR PUBLIC RELEASE, DISTRIBUTION UNLIMITED.



NAVAL WEAPONS STATION EARLE
Colts Neck, New Jersey 07722

UNCLAS

SECURITY CLASSIFICATION OF THIS PAGE (When Data Entered)

REPORT DOCUMENTATION PAGE		READ INSTRUCTIONS BEFORE COMPLETING FORM
1. REPORT NUMBER NWHC 7786	2. GOVT ACCESSION NO.	3. RECIPIENT'S CATALOG NUMBER
4. TITLE (and Subtitle) Packaging for 76 MM Otto Melara Ammunition, Phase I,		5. TYPE OF REPORT & PERIOD COVERED Phase I
7. AUTHOR(s) D. D. MacLeod		6. PERFORMING ORG. REPORT NUMBER NWHC-7786
9. PERFORMING ORGANIZATION NAME AND ADDRESS WPNSTA Earle Naval Weapons Handling Center Colts Neck, New Jersey		8. CONTRACT OR GRANT NUMBER(s)
10. PROGRAM ELEMENT, PROJECT, TASK AREA & WORK UNIT NUMBERS N/A		11. CONTROLLING OFFICE NAME AND ADDRESS
12. REPORT DATE September 1977		13. NUMBER OF PAGES 127
14. MONITORING AGENCY NAME & ADDRESS (if different from Controlling Office) 12 140p.		15. SECURITY CLASS. (of this report) Unclass
16. DISTRIBUTION STATEMENT (of this Report) Approved for public release; distribution unlimited		15a. DECLASSIFICATION/DOWNGRADING SCHEDULE N/A
17. DISTRIBUTION STATEMENT (of the abstract entered in Block 20, if different from Report)		
18. SUPPLEMENTARY NOTES		
19. KEY WORDS (Continue on reverse side if necessary and identify by block number) 76 MM Ammunition Environmental tests Containers Design tradeoffs Life cycle cost comparison Manufacturing process Material properties		
20. ABSTRACT (Continue on reverse side if necessary and identify by block number) This report presents the results of a study program initiated to meet the packaging requirements of the 76 mm/62 Cartridge Ammunition for the period from 1977-2010. This program included consideration of container materials, manufacturing processes and environmental requirements. Trade-off studies were accomplished on design requirements, logistics factors and life cycle cost comparisons.		

DD FORM 1473 1 JAN 73 EDITION OF 1 NOV 65 IS OBSOLETE

SECURITY CLASSIFICATION OF THIS PAGE (When Data Entered)

410 058

LB

Containers manufactured from aluminum, spiral wrap paper, fiberglass, steel, polystyrene and polyethylene were investigated, and ranked in this order for the application considered. An aluminum fabricated manufacturing process was found to have the lowest potential costs over any alternate aluminum manufacturing method. The spiral wrap process was found to have lower expected unit costs than any other available choice. Limited environmental test on material samples indicated that aluminum, spiral wrap paper, fiberglass and steel containers should withstand the container environment satisfactorily. Design trade-offs indicated that containers with integral stacking features (unit load interlocks) and designed for minimum size for the cartridge would be cost effective decisions. Logistic decision as to whether the container should be compatible to the modified 3"/70 Container or design optimized for the 76 mm cartridge is dependent on user ships alternation cost and could not be decided at this point. Life cycle cost comparisons were formulated based on a model developed on a sample scenerio for the time frame considered, for three types of containers. The types of containers considered were reusable containers, semi-recoverable containers and throwaway containers. Life cycle costs of each type of container can be directly compared to any other container when the unit cost of the container and the type of container is determined. Life cycle costs of the aluminum fabricated container and the spiral wound paper container were projected to less than one third that of new procurement of the existing container.

Two containers were recommended for prototype development and evaluation to base the final decision on a replacement container. They are the aluminum fabricated container and the spiral wrap paper container.

Prepared by: D. D. MacLeod
 D. D. MacLEOD
 Surface Warfare
 Systems

Reviewed by: S. R. Petoia
 S. R. PETOIA
 Surface Warfare
 Systems

Approved by: E. Kelly
 E. KELLY
 Director

ACCESSION IN	
RTIS	White Section <input checked="" type="checkbox"/>
DDC	Full Section <input type="checkbox"/>
UNCLASSIFIED	<input type="checkbox"/>
MULTIPLICATION	
BY	
DISTRIBUTION/AVAILABILITY CODES	
Dist.	AVAIL. and/or SPECIAL
A	1

PACKAGING FOR
76 MM OTTO MELARA AMMUNITION

TABLE OF CONTENTS

	<u>PAGE NO.</u>
1. INTRODUCTION	1
1.1 History of the 76 mm Packaging Program	1
1.2 Present Status of the 76 Packaging Program	1
2. OBJECTIVES	1
2.1 Program Goals	1
2.1.1 Investigation of 76 mm Packaging Concepts	1
2.1.2 Selection of Prototype Candidates	1
2.1.3 Plan for Prototype Development Program	1
2.2 Design Goals	2
2.2.1 Compatibility with Ships Configuration	2
2.2.2 Recommended Design Features	2
2.2.2.1 End Cover Design	2
2.2.2.2 Unit Load Recommendations	2
2.3 Technical Goals	2
2.3.1 Container Material Screening and Selection	2
2.3.1.2 Container Manufacturing Processes Screening and Selection	2
2.3.2 Container Life Cycle Cost Goals	3
2.3.2.1 Investigation of Container Life Cycle Costs	3
2.3.2.2 Recommendations on Container Alternatives Developed from Life Cycle Costs	3
3. PROGRAM DEVELOPMENT	3
3.1 Interaction of Criteria	3
3.2 Preliminary 76 mm Container Design	3
3.3 Prototype 76 mm Containers	3
3.4 Simulated Container Sample Development	3
3.5 Manufacturing Contacts	4
4. TRADE-OFF STUDIES	4
4.1 Trade-off between Built-in Container Stacking Features versus Unit Load Pallet Adapters	4
4.2 Trade-off in Maintaining Container Length the same as the 3"/70 Tank versus Optimizing Length for the 76 mm Cartridge	6
4.3 Logistic Support Trade-off	6
4.3.1 The Logistic Advantages of Supporting a Two Container System	6

	<u>PAGE NO.</u>
4.3.2 The Logistic Advantages of Designing a Pack Compatible with the Present 3"/70 Container	7
4.4 Recommendations Resulting from Trade-off Studies	7
5. CONTAINER RECOMMENDATIONS BASED ON MATERIAL, ENVIRONMENTAL TESTS MANUFACTURING PROCESSES AND COST	8
5.1 76 mm Package Characteristics and Screening	8
5.1.1 Aluminum	8
5.1.2 Spiral Wrap Paper	8
5.1.3 Fiberglass	8
5.1.4 Steel	10
5.1.5 Molded Polystyrene	10
5.1.6 Polyethylene	10
5.2 Matrix of 76 mm Pack Costs	10
5.3 Limited Environmental Tests	13
5.3.1 Aluminum	13
5.3.2 Spiral Wrap Paper	13
5.3.3 Fiberglass	13
5.3.4 Steel	14
5.3.5 Molded Polystyrene	14
5.3.6 Polyethylene	14
5.4 Material Manufacturing Processes	15
5.4.1 Aluminum Manufacturing Processes	15
5.4.1.1 Aluminum Formed Containers	15
5.4.1.2 Aluminum Fabricated Containers	15
5.4.2 Spiral Wrap Paper	15
5.4.3 Fiberglass	15
5.4.4 Steel	16
5.4.5 Molded Polystyrene	16
5.4.6 Polyethylene	16
5.5 Recommendations on Containers Based on Materials Manufacturing Processes and Limited Environmental Tests.	16
6. LIFE CYCLE COST	17
6.1 Life Cycle Cost for Container Types	18
6.1.1 Reuseable Container Life Cycle Cost	18
6.1.2 Semi-Recoverable Container Life Cycle Cost	18
6.1.3 Throw Away Container Life Cycle Cost	18
6.1.4 Comparison of Container Life Cycle Costs	22
6.2 Recommendations Resulting from Life Cycle Cost Studies	22
6.2.1 Recommended Container Types Based on Life Cycle Cost	22
6.2.2 Recommended Cost Effective Features	22
6.2.3 Container Procurement Quantity Recommen- dations Based on Life Cycle Costs	25

	<u>PAGE NO.</u>
7. RECOMMENDED PROTOTYPE 76 MM CONTAINERS	25
7.1 Spiral Wrap Container	25
7.1.1 Spiral Wrap Container Manufacturing Costs	28
7.1.2 Spiral Wrap Container Life Cycle Costs	29
7.2 Aluminum Fabricated Container	29
7.2.1 Aluminum Fabricated Container Manufacturing Costs	30
7.2.2 Aluminum Fabricated Container Life Cycle Costs	30
8. PLAN FOR PROTOTYPE DEVELOPMENT PROGRAM	32
8.1 NWHC Prototype Development Program	32
8.1.1 Prototype Procurement	32
8.1.1.1 Design Specification	32
8.1.1.2 Preliminary Drawings	32
8.1.1.3 Prototype Procurement Package	32
8.1.2 Prototype Evaluation Program	32
8.1.3 Environmental Test Program	32
8.2 Manufacturers Prototype Program	33
8.2.1 Manufacturing Drawings	33
8.2.2 Fixtures and Soft Tooling	33
8.2.3 Manufacture of Prototype Container	33

LIST OF ILLUSTRATIONS

<u>FIGURE NO.</u>	<u>DESCRIPTION</u>	<u>PAGE NO.</u>
1	WR 54/263 Fleet Issue Unit Load 76 mm Cartridge in Pallet Adapter MK 121 MOD 0	5
2	WR 54/Sample Fleet Issue Unit Load 76 mm Cartridge in Proposed Container	5A
3	76 mm Package Characteristics	9
4	76 mm Package Cost	11
5	Graph - Life Cycle Costs for 80% Reuseable Container	19
6	Graph - Life Cycle Costs for 50% Recoverable Container	20
7	Graph - Life Cycle Costs for Throwaway Container	21
8	Graph - Life Cycle Cost for Three Basic Types of Containers	23
9	Graph - Procurement Costs for 76 mm Containers	24
10	Graph - Unit Cost of 76 mm Con- tainer Versus Quantity Procured	26
11	Graph - Cumulative Procurement Quantity Necessary to Meet Re- quirements during the Life of the Program	27
12	Sketch - 76 mm Cartridge Container	31
13	Program Schedule and Cost 76 mm Prototype Container	34

APPENDICES

A	Life Cycle Model	A-1
B	Life Cycle Costs	B-1
C	Referenced Material	C-1

1. INTRODUCTION

1.1 History of the 76 mm Packaging Program. The Naval Weapons Handling Center (NWHC), Naval Weapons Station Earle, was directed by NAVSEASYSKOM (SEA Task 052-103-011/001) to investigate alternative designs and concepts for cartridge tanks used with the 76 mm/62 ammunition. This ammunition was introduced with the NATO decision to procure the Italian Otto Melara gun system for Navy ships. A decision was made at the time of its introduction to package 76 mm rounds in MK II MOD 0 Tanks, which were in supply and no longer used for the obsolete 3"/70 ammunition. The existing supply of MK II Tanks will be depleted at some time in the not too distant future through attrition and increased use of the 76 mm gun and ammunition; therefore, procurement of additional tanks will be necessary to meet the increasing needs.

The NWHC study program was initiated to generate recommendations for a 76 mm Container. The study encompassed alternative designs, materials, manufacturing processes, trade-offs, and costs which would result in recommendations for an improved container with the technology of the 1970's to supplement and eventually replace the World War II designed MK II Containers.

1.2 Present Status of the 76 mm Packaging Program. The container study program has been completed. This report has been prepared to present the results of the study with the conclusions reached and the recommendation for continuing the program to the prototype development phase, which will follow. Continuing the 76 mm program as detailed herein will assure that a 76 mm container will be available when required to meet the transition from the MK II container to whatever package is selected.

2. OBJECTIVES

2.1 Program Goals. The program goals of this study program are to investigate the packaging techniques which could best be applied to 76 mm ammunition, and to recommend the optimum container options for further study during a proposed prototype development program.

2.1.1 Investigation of 76 mm Packaging Concepts. The goals are to investigate packaging concepts such as single or multiple packs, design of containers; and the materials and methods of manufacturing containers which are the best suitable for the application.

2.1.2 Selection of Prototype(s) Candidates. The goals of the study program are to propose one or more of the most promising packaging concepts for further development. This will enable the best alternative container to be selected from one of the proposed prototypes based on the evaluation of the prototypes.

2.1.3 Plan for Prototype Development Program. Another of the study program goals is to propose a prototype development plan and

program by which further evaluation of recommended prototype configuration can be conducted in an efficient and timely manner.

2.2 Design Goals. The following design goals are the desired results of the study program for the 76 mm packaging.

2.2.1 Compatibility with Ships Configuration. Whichever design is recommended for development, the first order priority must be for compatibility with ships systems which includes magazine stowage, handling systems, ammunition hoists, compatibility with MK II containers and unit loads. A multiple container and bulk pack were eliminated at the outset of the program because of the extensive ship alterations, which would be required at a prohibitive price.*

2.2.2 Recommended Design Features. During the study designs were investigated to recommend incorporation of the most desirable features for whichever container is finally proposed.

2.2.2.1 End Cover Design. One of the most important features of design is the end cover design. It is highly desirable to have a cover which can seal the container, be easily installed and removed while ammunition is stacked cordwise, and remains positively locked while stored and handled.

2.2.2.2 Unit Load Recommendations. The container design must be suitable for incorporation into a unit load. This means that palletizing, strapping, possible interlocking features or stacking using adapters to make up unit load must be considered. Shipping and handling must be facilitated within the dimensional and weight limitations of a domestic and fleet issue unit load.

2.3 Technical Goals. The technical goals of this study program are to investigate the materials, manufacturing processes and costs associated with the proposed container(s) for the 76 mm ammunition and recommend the best for further development.

2.3.1 Container Material Screening and Selection. The objective is to select the materials best suited for the type of container to be designed for the 76 mm round. Criteria for material selection will be chosen and suitable materials matched against the requirements. The criteria will be concerned with physical properties and environmental considerations.

2.3.1.2 Container Manufacturing Processes Screening and Selection. From the materials found most suitable for the 76 mm alternate container the manufacturing processes will be investigated to obtain the most effective process for manufacturing the required quantities of containers.

*WH 8025 ser 1546-74 letter dated 6 November 1974 (enclosed in Appendix C).

2.3.2 Container Life Cycle Cost Goals. Factors contributing to life cycle costs of containers will be investigated to find the effects and trade-offs to arrive at the container with the lowest life cycle costs.

2.3.2.1 Investigation of Container Life Cycle Costs. Procurement, operating and support costs will be investigated to determine their relationship in comparisons of life cycle cost.

2.3.2.2 Recommendations on Container Alternatives Developed from Life Cycle Costs. The factors involved in life cycle cost of containers will be considered in determination of recommendations based on obtaining lowest life cycle costs for an alternative container.

3. PROGRAM DEVELOPMENT

The study program was organized to develop the 76 mm packaging along several courses of action and has proceeded to ultimately recommend the best combination of design, materials, and method of manufacture. This will result in the container having the lowest initial cost, lowest life cycle cost with the best logistic and handling considerations for a 76 mm container.

3.1 Interaction of Criteria. Each of the program objectives considered individually interacts with some or all of the other criteria. Therefore, this report organizes the results of the study in a manner which provides a substantiation of the conclusions and recommendations produced. The trade-offs and/or assumptions generated are also presented.

3.2 Preliminary 76 mm Container Designs. The 76 mm packaging program commenced by preparing outline drawings with which it was planned to evaluate different materials and manufacturing processes by obtaining prototype samples of the most promising concepts (See Appendix C). It was planned to conduct environmental tests to indicate the advantages and disadvantages of each concept. This straight forward method would result in final recommendations on which to base the selection of the optimum 76 mm alternate pack.

3.3 Prototype 76 mm Containers. It was found that prototype containers based on design concepts could not be obtained which would be similar to production units without special tooling. The tooling required for prototypes was found to be substantially the same tooling required for production units and at substantially the same cost as the production tooling. Thus, development was limited to more modest objectives because of the high costs.

3.4 Simulated Container Sample Development. In lieu of prototype containers, samples of alternate materials were obtained from manufacturers. Where possible, tube samples were obtained with diameters and lengths as close to the 76 mm size available. NWHC made up ends of assorted materials which were taped or jury rigged to the tubes. With

these samples it was possible to conduct limited environmental testing consisting of leak checks, temperature variations and drop or impact test of the materials. It was not possible to check out the design features such as stacking features, end closures, cartridge retention and handling provisions. These evaluations will have to await actual prototype samples.

3.5 Manufacturing Contacts. Contacts were made with potential suppliers specializing in manufacturing containers of different materials and manufacturing processes. Samples of material in tubing forms were provided NWHC for testing purposes. At the completion of limited tests the manufacturers were again contacted for additional information on materials, quotes for prototype and production quantities, and for their recommendations on the most efficient methods of manufacturing. NWHC prepared additional drawings for different container types, with minimum detail included to allow the manufacturers maximum freedom in manufacturing components.

4. TRADE-OFF STUDIES

This section contains the trade-offs and comparisons involved in container features which may or may not be desirable. Recommendations are provided based on the results of these studies.

4.1 Trade-off Between Built in Container Stacking Features versus Unit Load Pallet Adapters. Pallet adapters are used in restraining cylindrical containers firmly in place on the pallet. Interlocking provisions (stacking features) which accomplish the same purposes may be designed integral into the container, thereby making adapters unnecessary. Pallet adapters are used with the present 3"/70 MK 11 container for the 76 mm cartridge. These MK 12 adapters were last purchased in 1975 for \$25.24 per set. Two adapter sets are required for a unit load of 36 containers, therefore, the unit price per container is \$1.40. These adapters, on an average, are used twice during their lifetime so that one half of the cost is recoverable. The adapter also requires specialized labor to make up the unit loads, whereas, the unit load with built in stacking features can be quickly made up by inexperienced personnel. A reasonable assumption is that 20 minutes more will be required to palletize a load with adapters. Assuming a labor cost of \$20 per hour, the per container cost is \$.18. Considering labor, adapters cost an average of \$1.58 (\$1.40 + \$.18) per container, although \$.70 is recoverable leaving a net expendable cost of \$.88 per container (\$1.40 \div 2 + \$.18). Containers with built in stacking features can probably be included for less than \$1.00 per container more than for containers without stacking features. Adapters must be procured, stacked and supported, which is an added burden in the supply loop. It would seem that built in stacking features offer advantages which, in addition to the convenience, would be cost effective if available for slightly more than \$.88 per container. WR 54/263 (Figure 1) illustrates the present Fleet Issue Unit Load for the 76 mm unit load utilizing the MK 11 Cartridge Tank and the MK 12 Pallet Adapter. WR 54/Sample (Figure 2)

Code Ident
10001

Naval Sea Systems Command
Department of the Navy

**WEAPONS REQUIREMENT, PALLTIZING
FLEET ISSUE UNIT LOAD
CARTRIDGE, 76MM/62 CAL OR CHARGE, CLEARING, 76MM/62 CAL
IN PALLET ADAPTER MK 121 MOD 0**

UNIT LOAD DATA

	CARTRIDGE	CLEARING CHARGE
NUMBER OF CARTRIDGES PER TANK	1	1
NUMBER OF TANKS PER ADAPTER	18	18
NUMBER OF TANKS PER UNIT LOAD	36	36
GROSS WEIGHT OF ONE TANK (APPROX.)	16.5 KG 36.4 LBS	9.4 KG 20.8 LBS
WEIGHT OF ONE ADAPTER, EMPTY (APPROX.)	20.9 KG 46.0 LBS	20.9 KG 46.0 LBS
GROSS WEIGHT OF ONE ADAPTER, LOADED (APPROX.)	320.2 KG 706.0 LBS	192.9 KG 429.0 LBS
WEIGHT OF PALLET, MK 3 MOD 0 (APPROX.)	42.6 KG 94.0 LBS	42.6 KG 94.0 LBS
WEIGHT OF STRAPPING (APPROX.)	6.6 KG 14.5 LBS	6.6 KG 14.5 LBS
GROSS WEIGHT OF UNIT LOAD (APPROX.)	685.4 KG Δ 1511.0 LBS	430.5 KG Δ 949.0 LBS
CUBE	1.2657 CU METER 44.7 CU FT	1.2657 CU METER 44.7 CU FT

Δ DO NOT USE FOR SHIPPING PURPOSES

DO NOT STACK MORE THAN
4 UNIT LOADS HIGH IN STORAGE

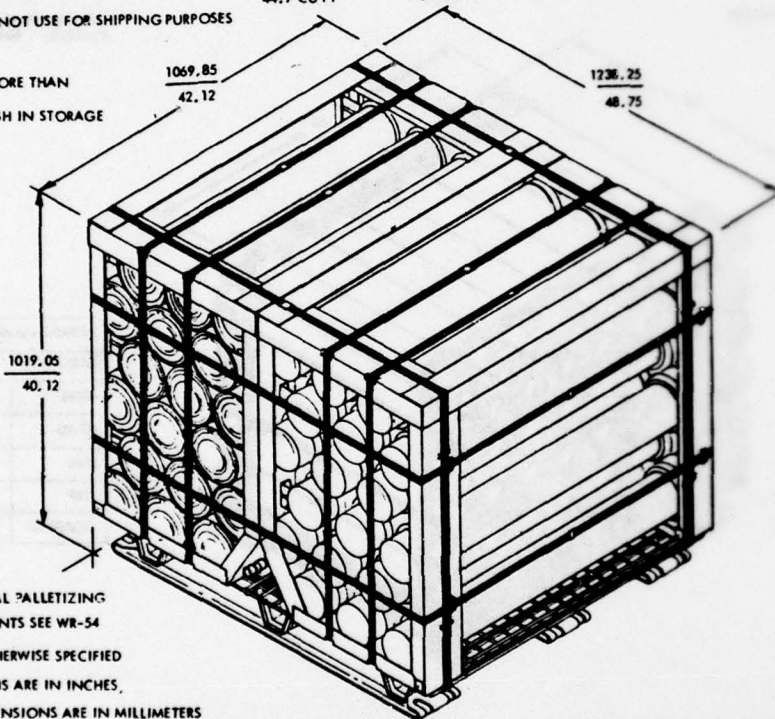

FOR GENERAL PALLTIZING
REQUIREMENTS SEE WR-54
UNLESS OTHERWISE SPECIFIED
DIMENSIONS ARE IN INCHES,
ABOVE LINE DIMENSIONS ARE IN MILLIMETERS

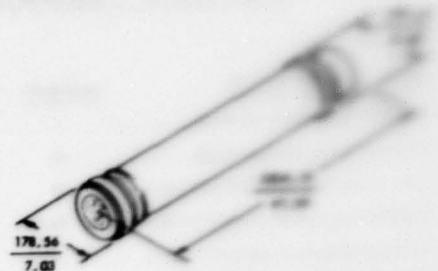

SHIPPING CONDITION
BY CARTRIDGE: 1000 - 10000
(CARTRIDGE) 1000 - 10000
(CHARGE) 1000 - 10000

CARTRIDGE	UNIT	QTY
WE-18	"	36
WE-20	"	36
WE-27	"	36
TRP	"	36
CLEARING	"	36

SEE MIL-HDBK-236 (NAVY) "INDEX TO STANDARDS" FOR APPLICABLE TRUCKLOADING, CARLOADING AND CONTAINER LOADING DOCUMENTS.		REV LTR	REVISION DESCRIPTION	DATE	TDA	APPROVAL
WE NO.	ASSOCIATED PROCESS					
<p>THIS UNIT LOAD IS AUTHORIZED AND RELEASED FOR SHIPPING, HANDLING STORAGE AND TRANSFER-AT-SEA. IT MAY ALSO BE USED FOR SHIPMENT BY COMMON CARRIER IN COMPLIANCE WITH DOT REGULATIONS.</p>						
<p><i>M.S. Gray</i> NWHL 10/16/74 SIGNATURE TECHNICAL DIRECTING ACTIVITY (TDA) DATE</p> <p><i>J.E. Kelly</i> 10/16/74 SIGNATURE SEA SYSCOM, BY DIRECTION DATE</p>		<p>ORIGINATOR <i>L.P. Carangi</i> SIGNATURE</p> <p>NAVAL WEAPONS HANDLING LABORATORY U.S.N.A.D. EARLE, NEW JERSEY</p>				

**WEAPONS REQUIREMENT, PALLETIZING
FLEET ISSUE UNIT LOAD
CARTRIDGE, 24MM/62 CAL OR CHARGE, CLEARING, 76MM/62 CAL**

UNIT LOAD DATA

	CARTRIDGE	CLEARING CARTRIDGE
NUMBER OF CARTRIDGES PER TRAIL.....	1	1
NUMBER OF TRAILS PER UNIT LOAD.....	48	48
GROSS WEIGHT OF ONE TRAIL (APPROX.)....	28	17.4
WEIGHT OF BALLIST, MK 3 M82 0 (APPROX.)...	94.0 lb	94.0 lb
WEIGHT OF STRAPPING (APPROX.).....	9.0 lb	9.0 lb
GROSS WEIGHT OF UNIT LOAD (APPROX.)	147 lb	142.2 lb
CBF	44.1 CU FT	44.1 CU FT

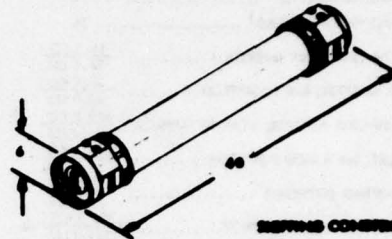

STOWING CONDITION
IN CARTRIDGE TRAIL MK
(CARTRIDGE) MK3 - 24MM
(CHARGE) MK3 - 76MM

△ DO NOT USE FOR STOWING PURPOSES

DO NOT STACK MORE THAN
4 UNIT LOADS PER PALLET

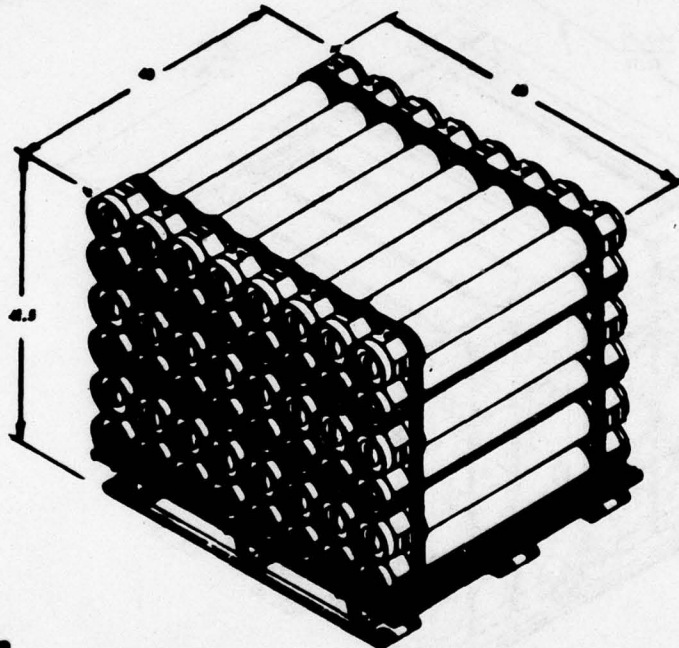

WEAPON CLASSIFICATION		
CARTRIDGE	DOT	CS
MS-62	A	E
MS-76	A	E
MS-76	B	E-0
MS-76	B	E-0
CLEARING	B	E-0

FOR GENERAL PALLETIZING
REQUIREMENTS SEE WB-54
UNLESS OTHERWISE SPECIFIED
DIMENSIONS ARE IN FEET

(1) MS-62-62 (NAVY) (2) MS-76-76 (NAVY) (3) MS-76-76 (NAVY) (4) MS-76-76 (NAVY) (5) MS-76-76 (NAVY) (6) MS-76-76 (NAVY)		DOT	SECTION DESCRIPTION	DATE	NSA	NSM	SYSCOM
THIS UNIT LOAD IS AUTHORIZED AND RELEASED FOR STOWING, HANDLING, STORAGE AND TRANSFER-AT-SEA. IT MAY ALSO BE USED FOR SUPPORT BY COMBINED CARRIER IN COMPLIANCE WITH DOT REGULATIONS.		ORIGINATOR _____ NAVAL WEAPONS HANDLING CENTER WOODRIDGE EARLE, NEW JERSEY					
SIGNATURE TECHNICAL DIRECTOR ACTIVITY (DA) DATE SIGNATURE (A) (NSA) (NSM) (SYSCOM), BY SECTION DATE		PAGE 1 OF 3					

5A FIGURE 2

proposes the 76 mm Fleet Issue Unit Load utilizing the recommended configuration container without pallet adapter.

4.2 Trade-off in Maintaining Container Length the Same as the 3"/70 Tank versus Optimizing Length for the 76 mm Cartridge. It is expected that the alternate container specifically designed for the 76 mm Cartridge can be 1-3/8 inches shorter than the MK II Cartridge Tank. The basic manufacturing cost savings is 3.3% per container based on reducing the length from 41-3/8 inch. On a container costing \$12.00 this savings could amount to \$.40 per container. The minimum number of 80% reusable containers required is 461,308 thus the resultant minimum procurement savings is \$184,500. If 50% recoverable containers are considered the savings are \$334,871 for 930,199 containers. It is possible that a ships alteration might be required to reposition the stanchions in the ships magazines to handle the slightly smaller container. There will be a number of MK II Tanks available throughout a portion of the life of the program which could be exclusively used to support a class of ships if ship alterations required for these particular ships are more than minimal. The cost of ships alterations would offset the possible cost savings.

4.3 Logistic Support Trade-off. It is assumed that the present 3"/70 MK II Cartridge Tank will be supported throughout the lifetime of the 76 mm program because of the large number of containers available. Therefore, the trade-off is that of designing a container which is compatible to the MK II tank and that of designing an optimum container and logistically supporting a two container system.

4.3.1 The Logistic Advantages of Supporting a Two Container System.

- Unit load for the new container could probably be designed to hold 48 rounds instead of 36 utilizing the MK II tank with a minimum increase in size (41-1/2 x 40 x 48) versus (40-1/8 x 42-1/3 x 43-3/4), respectively.

- Ships magazines could hold an increased number of rounds in the same size space because of the smaller sized containers.

- The container could probably be designed with stacking features so that adapters would not have to be designed, procured and supported.

- Logistics support cost could probably be reduced by the design of a container with lower renovation costs obtained by strengthening the container.

- A newly designed container with state of the art improvements in manufacture and features would be less costly than new procurement of the existing container.

- Fewer pallets required for shipment of equivalent number of projectiles due to probably smaller sized containers for the recommended packs.

- Lower packing costs would result from probable elimination of adapters and reduction of labor required to make up unit loads.

4.3.2 The Logistic Advantages of Designing a Container Compatible with the Present 3"/70 Container.

- Minimum documentation changes required for WR unit load.

- Ship alterations for stowage would not be required for compatible containers.

- Separate storage would not be required for MK II and 76 mm compatible containers.

- Simplified stacking and handling of 76 mm ammunition.

- The present 3"/70 container will still require continued support unless it is completely replaced at some point with the new 76 mm pack. Because of the large number of 3"/70 containers and the high cost of replacing them, this container will probably remain in the system. The logistic advantages of supporting a container compatible with the present 3"/70 container favor this approach. However, the program advantages of an optimum container design indicate that overall progress would result from designing a pack with the smallest size and simplest unit load which would in the long term produce advantages that would make up for the changes necessary in logistics support of 76 mm ammunition.

4.4 Recommendations Resulting from Trade-off Studies. The result of the built in stacking features versus the adapter study indicates that it is desirable to include built in stacking features if these features can be included within an estimated production cost of \$.88 per container. Maintaining the container length equal to the presently used 3"/70 container results in a minimal increase (3.37%) in unit container cost, and may be desirable to avoid any ships alteration cost due to installation of additional stanchions which might be required by a shorter container. User ships configuration study would have to be accomplished by Naval Ships Engineering Center to investigate whether the alteration could be accomplished for less than the savings possible with a shorter tank. Three percent of \$12 unit price container x 930,199 containers 50% recoverable, or \$334,871, is a reasonable estimate of the savings achievable with a shorter tank. The logistics factors favor design of a container compatible with the present 3"/70 container, however, other factors discussed in this report on life cycle costs container materials, and manufacturing processes tend to counterbalance this tentative conclusion resulting only from logistics considerations.

5. CONTAINER RECOMMENDATIONS BASED ON MATERIALS, ENVIRONMENTAL TESTS, MANUFACTURING PROCESSES AND COST

This section outlines the investigation for the best container for 76mm cartridges. The main elements involved in this selection process are the cost, choice of materials, results of environmental tests conducted, and manufacturing processes.

5.1 76 mm Package Characteristics and Screening. A matrix (Figure 3) was prepared which includes all the materials considered for the alternate container. Most of the important characteristics for a container are listed. Each material's ability to meet each desired characteristic was graded from excellent (4) to poor (1). The grades were totaled for each material. From the chart it can be seen that aluminum received the highest score followed by spiral wrap paper, fiberglass, steel, and plastics respectively. This section discusses material selection in more detail than possible in the chart format.

5.1.1 Aluminum. According to the matrix aluminum is the best material for an alternate 76 mm container. Historically aluminum displaced steel for cartridge and propelling charge tanks during World War II. These same containers are still in service 30 years later which proves the durability. It is reasonable to assume that this material is still highly satisfactory and would be displaced only if some alternate material possessed superior characteristics or significantly lower costs. It is considered as the "standard" of comparison for all other container designs.

5.1.2 Spiral Wrap Paper. The matrix indicates this material is the second choice for a container material. This container although made on a paper base is a composite, and as such has the flexibility of being tailored to provide some of the characteristics most desired. The Army utilizes a plain type of spirally wrapped tube with metal ends and a telescoping cover for their 76 mm cannon ammunition. The matrix indicates that the Army container ranks further down on the desirability scale than the proposed improved version for Navy use, as suggested by NWHC, because of the added design features.

There are potential production problems which might occur with the spiral wrap container. Since it is made up of layers of different materials held together by adhesives, it is possible to have quality control problems. The possibilities exist of overlay variance, type and nonuniformity of adhesives used, amount of adhesives, uniformity of coatings; uniformity of materials, and susceptibility to changing manufacturing temperature humidity conditions. These variables may possibly cause blisters, leaks, soft spots, and chemical reactions with materials such as lubricants and hydraulic fluid, that the containers might come in contact with during their normal use.

5.1.3 Fiberglass. Fiberglass appeared as a promising alternate material. It is successfully used in missile containers; it is strong,

FIGURE 3. 76 MM PACKAGE CHARACTERISTICS

MATERIAL	ALUMINUM		STEEL		POLYETHYLENE		POLYSTYRENE		SPIRAL WRAP		
	EXISTING MK II TANK	MODIFIED MK II TANK	FABRICATED A/N CAN	A/N CAN	ROTOMOLD	INJECTION MOLD	FIBERGLASS	ARMY TYPE	NWHC DESIGN	PAPER TYPE	WRAP DESIGN
Weight	2	2	2	3	2	2	4	4	4	4	4
Cube	4	4	4	4	3	3	1	4	4	4	4
Tensile Strength	4	4	4	4	3	3	1	2	2	2	2
Stacking Features	4	4	4	1	4	4	3	1	4	1	4
Compatibility with Existing PF & PHM	4	3	3	2	3	3	1	3	3	3	3
Ability to withstand Strapping	4	4	4	4	4	4	1	3	2	2	2
End Removal of Projectile	1	4	4	1	4	4	3	1	4	1	4
Low Temperature	4	4	4	4	2	2	3	3	4	4	4
High Temperature	4	4	4	4	2	2	2	2	3	3	3
Flamability	4	4	4	4	1	1	1	2	2	2	2
Water Proof	4	4	4	4	3	3	2	3	3	3	3
Vapor Proof	4	4	4	4	3	3	1	3	3	3	3
Vibration	4	4	4	4	4	4	4	4	4	4	4
Drop Test	3	3	3	1	2	2	1	3	3	3	3
TOTAL	50	50	50	43	40	40	28	43	38	44	44

4 - Excellent
 3 - Good
 2 - Fair
 1 - Poor

tough, weather resistant and can withstand a wide temperature range. It appears to be well suited as a container material based on its material properties.

5.1.4 Steel. Steel came out tied for third place on satisfying the list of desirable characteristics. A lightweight A/N can type was considered as an alternate container. Steel has high strength, but is subject to severe corrosion and deterioration over a long use period unless successfully protected. It is worth investigating further as a possible alternate material.

5.1.5 Molded Polystyrene. Among synthetic materials polystyrene has been in widespread use for fabrication of containers. Therefore, because of several desirable characteristics, i.e., low cost, lightweight, good insulating properties, this material was examined for 76 mm ammunition container application. The material provides good heat insulation with a heat transfer coefficient (K) of .21 and can be treated to be self extinguishing when subjected to fire. The estimated weight for a potential container is two pounds, but the container required wall thickness is about 1-1/2 inches to mitigate the 3 feet drop which is the maximum test shock applied. Other disadvantages are the polystyrene is susceptible to water penetration, is not biodegradable, and cannot be discarded at sea since it floats. The material has one time impressibility and is susceptible to scuffing and cutting, which would probably prevent reuse of the container. Polystyrene offers several good material properties, but is not felt to be suitable for the sole container material. NWHC has tested overcoating material applied by spray and dip processes with limited success. A coating of ABS (thermoplastic material with a 350°F softening temperature) would provide extended life to the container by minimizing external handling damage, while at the same time enabling some size reduction at a significant cost increase of approximately 50%. It was decided to eliminate this material from further consideration, mostly because of the larger container size required as opposed to other alternates, plus the other disadvantages noted.

5.1.6 Polyethylene. Polyethylene is an inexpensive plastic material, which at first glance appears attractive as a 76 mm container candidate. NWHC developed a sonobuoy container several years ago which proved satisfactory. At the same time as this development was undertaken, a modification was made which adapted it to a 5 inch propellant charge tank. The sonobuoy container was treated to make it slow burning. This was satisfactory for ashore storage but unsuitable for shipboard application. Fire retardent treatments were investigated, but the resulting low temperature properties (brittleness) caused by the retardent treatment made it unsuitable for consideration. At such time that polyethylene material which is fire retardant and retains resiliency at low temperatures is found, it would merit consideration for a similar application.

5.2 Matrix of 76 mm Package Costs. This matrix (Figure 4) indicates in tabulated form the cost factors involved for each alternative

FIGURE 4. 5.4 76 MM PACKAGE COST

MATERIAL	ALUMINUM		STEEL FABRICATED A/N CAN	ROTOMOLD	INJECTION MOLD	POLYSTYRENE FIBERGLASS		SPIRAL WRAP	
	EXISTING MK II TANK COST	MODIFIED MK II TANK COST				ARMY 77 MM DESIGN	NWHC DESIGN		
Tooling Cost	(3)	\$100,000	\$39,000	\$5,000	\$10,000	\$3,000	\$75,000	(1)	\$35,000
Material Cost/lb.		\$.90/lb.	\$.90/lb.	\$2.00/lb.	\$2.00/lb.	\$1.00/lb.	\$1.50/lb.	NA	NA
Est. Container Weight		8 lb.	6 lb.	4 lb.	4 lb.	2 lb.	10 lb.	6 lb.	6 lb.
Matl. Cost/Unit		\$7.20	\$5.40	\$8.00	\$8.00	\$2.00	\$15.00	\$1.50	\$1.50 est.
Unit Cost Range		\$35-43	\$12-20	\$10-13	\$9-15	\$2-6 (2)	\$26-35	\$2-5	\$12.50-20
Adapter Cost/Unit		\$3.25	Not Req'd	Not Req'd	Not Req'd	\$1.76 (5)	Not Req'd	\$.88	Not Req'd
Recoverability Expected		80%	80%	50%	50%	0	80%	0	50%
Unit Container Expected Cost		\$42.25	\$16.00	\$11.50	\$12.00	\$5.76	\$30.50	\$4.38	\$6.25
Unit Scrap Value		\$2.64 at .33/lb.	\$2.64 at .33/lb.	No Value	No Value	No Value	No Value	No Value	No Value
Estimated Life Cycle Cost		\$32.7 million (4)	\$12.4 million (4)	\$12 million (4)	\$12.5 million	\$9.5 million	\$23.59 million	\$7.3 million	\$17.0 million

- (1) Army Procurement Contract from Picatinny for 76 mm Projectile
- (2) For Uncoated Polystyrene Container. Overcoating will approximately double the price.
- (3) Tooling may be on hand at last manufacturer's plant.
- (4) Life cycle cost does not consider the recoverable scrap price.
- (5) Twice the number of adapters are required for polystyrene containers because of their bulk therefore cost is $\$.88 \times 2 = \1.76 .

container considered for the 76 mm unit pack. The materials considered are aluminum, steel, plastics and paper.

An explanation of the entries in the matrix follows:

- Material Process. The manufacturing method of producing each type of container.
- Tooling Cost. Estimated cost of prototype and production tooling required for each manufacturing process.
- Material Cost Per Round. Raw material cost for each material considered.
- Estimated Container Weight. Gross estimated weight of container and cover assembly for each material considered.
- Material Cost Per Unit. Raw material cost per pound for each alternate material multiplied by the estimated weight of the container.
- Estimated Unit Cost Range. Normally expected range of container unit cost in quantity production (between 5,000 and 100,000 units). This does not include development program costs.
- Adapter Cost Per Unit. \$3.25 cost for 80% reusable container \$1.61 for semireusable container and \$.98 for throwaway container. Calculated for the number of containers of each type required. (Manufacturing methods and materials which can be designed with built in stacking features to replace the adapters have this cost omitted.)
- Recoverability Expected. Measure of probable container durability. 80% is a fully reusable container, 50% is considered semireusable container and 0% is a throwaway container.
- Unit Container Expected Cost. Mid-range value of expected unit cost range plus the adapter cost per round.
- Scrap Value. Expected recoverable cost of scrap of a demolished container.
- Estimated Life Cycle Cost. Mid-range unit priced container life cycle cost determined from Figures 5, 6 and 7 according to recoverability of container.

From this table, the lowest cost container is the spiral wrap paper container modified from the existing Army design. Next in order are polystyrene, roto molded polyethylene, injection molded polyethylene, fabricated aluminum, steel AN/can type, NWHC design spiral wrap paper, modified MK II aluminum formed tank, fiberglass and the most expensive tank the MK II existing tank.

5.3 Limited Environmental Tests. Certain limited environmental tests were conducted by NWHC to further check on material suitability. Material samples were obtained which represented a container configuration as close to the 76 mm size as possible to simulate a container.

5.3.1 Aluminum. The 3"/70 aluminum container presently used meets all requirements of a container, therefore, no further environmental tests were required or conducted to prove the suitability of aluminum for a container material.

5.3.2 Spiral Wrap Paper. Two samples of a 76 mm container were submitted by United Ammunition Container Co., to NWHC for testing. One sample had a flame resisting chipboard paper covered core with a spiral wrap aluminum foil interior skin and a polyethylene coated aluminum foil exterior skin. The other sample had the same core material covered by a black colored polyethylene on aluminum foil material. Both containers had their stamped metal ends secured to the tubes by a single crimp. The tubes were closed by a telescoping end cap and sealed with 2 inch wide fiberglass tape. The two containers passed leakage tests according to FED-STD-101B Method 5009 (e). One container leaked at a dent near the bottom of the tube but was sealed when repaired with 2 inch wide tape by NWHC. Further tests were successfully passed which consisted of two hours of repetitive shock at 4 Hz, one hour in the horizontal plane and one hour in the vertical plane with no visible damage. These containers were also subjected to 36 inch drop tests as prescribed in MIL-T-18492. The metal ends of the containers dented slightly, but the single crimped ends held to the spiral wrap tube and the internal form support absorbed the shock. The ends of the container would have to be strengthened for prototype. The manufacturer claims that the spiral wrap container is reusable, but tests indicates that a spiral wrap container cannot be considered to be as durable as one made out of metal. (2) (3) (4)

5.3.3 Fiberglass. A preliminary design was initiated and a simulated container made from a 5-1/8 inch diameter x .075 wall sample fiberglass cloth wound tubing. The tubing was closed at the ends with packing to represent the cover and closed end. This container was tested with a 76 mm dummy round. The sample survived a cold temperature drop test of 30 inches at -20°F per MIL-STD-648 requirements. Fiberglass tensile strength of 40,000 psi and good weathering ability under salt and fresh water conditions in a temperature range from -60°F to +350°F make fiberglass appear as an attractive container material alternate. (5)

-
- (2) Memorandum WH-8021-JA dtd 29 May 75 (enclosed in Appendix C)
 - (3) Memorandum WH-8051-JRB of 21 Jul 75 (enclosed in Appendix C)
 - (4) NWHL Report 7616 dtd Mar 76 (enclosed in Appendix C)
 - (5) Memorandum WH-8051-WHT dtd 5 Jan 76 (enclosed in Appendix C)

5.3.4 Steel. The physical properties of steel as applied to container design are well known and no environmental tests were conducted or thought to be necessary to determine suitability of steel for a container. (6)

5.3.5 Molded Polystyrene. A 7-1/2 inch diameter split tube of molded polystyrene, normally used for pipe insulation was used to make up a sample 76 mm container. Polystyrene end caps and joints along the split halves were sealed with one inch wide nylon reinforced glass type. The sample passed this 21 inch drop test according to MIL-STD-648 and FED-STD-101 requirements, however, the 76 mm round permanently depressed the end cap 1-1/4 inch with the tip of the projectile. (7) (8)

5.3.6 Polyethylene. Four sample containers were rotationally (roto) molded under NWHC observation. Roto molding is a simple process requiring an inexpensive mold and is suitable for large production lots. It was noted, by NWHC, that the manufacturer had quality control problems in maintaining temperatures, and moisture content at the proper levels. These problems changed the material properties and caused rejection of a number of containers in order to get a good representative sample of four. These four containers were subjected to a low temperature drop test at NWHC and two out of four failed the test. It was believed that the fire retardant treatment degraded the low temperature strength of the plastic. (8) (9) An Army 81 mm polyethylene container has had longitudinal stress cracks appear after manufacture on a large percentage of containers. (11) Another undesirable feature of polyethylene is that it becomes slippery when wet or cold which would cause obvious handling problems if a unit load was broken out on an exposed deck. A continuing search of various polyethylene materials and fire retardants has so far failed to find a suitable combination which would meet the fire retarding requirements and low temperature shock conditions. The noted deficiencies disqualify polyethylene as a viable container material at the present time.

-
- (6) NWHC Report 7631 dtd 7 May 76 Evaluation of Crush Resistance of Super RBOC Containers (enclosed in Appendix C)
 - (7) Memorandum WH-8052-VS dtd Aug 71, Test and Evaluation of Bulk Pack Polystyrene 5"/54 Cartridges Unit Load Fleet Issue Experimental (enclosed in Appendix C)
 - (8) Memorandum WH-8051-JEB dtd 23 Jul 76, Alternate Packaging Method (enclosed in Appendix C)
 - (9) Memorandum WH-8051-HT dtd 4 Nov 71, Test and Evaluation of 5"/54 Plastic Cartridge Tanks Self Extinguishing (enclosed in Appendix C)
 - (10) NWHC Report 7642 dtd 23 May 76, Cold Drop Tests of Rotationally Molded Plastic Containers (enclosed in Appendix C)
 - (11) Picatinny Arsenal Technical Report No. 4729 dtd Feb 75 (not enclosed)

5.4 Material Manufacturing Processes. Alternate manufacturing processes applicable to the respective materials which can be used to produce 76 mm containers were also examined, and the advantages, disadvantages and costs follow:

5.4.1 Aluminum Manufacturing Processes.

5.3.1.1 Aluminum Formed Containers. The present MK II aluminum container is formed from aluminum with cast end opening. The last manufacturer of this tank, who may still have the tooling, verbally quoted a unit price of \$43 for each container. Two other manufacturers estimated tooling costs between \$100,000 and \$125,000 and per unit container costs between \$25 and \$30. This would produce a satisfactory container, but at a very high unit cost.

5.4.1.2 Aluminum Fabricated Container. Preliminary design drawings were prepared for the purpose of defining the best method of manufacturing an aluminum container. It was originally thought that a deep drawn container design might be advantageous; however, it was found through manufacturers recommendations that a fabricated aluminum approach would be better. Deep drawn aluminum cylinders require expensive progressive dies, while aluminum precision tubing is commonly manufactured and stocked as irrigation pipe, relatively inexpensively. A fabricated container could be assembled using the required length of irrigation pipe with the ends either impact cast or stamped and rolled, or welded to the tubing. The cartridge retaining insert is proposed to be made of plastic. It was estimated by a manufacturer that soft tooling costs for about 100 prototypes would be about \$10,000. Hard production tooling for large quantity runs are expected to cost an additional \$29,000. The unit container is expected to cost \$11.75 each in quantity production not considering design, development or tooling costs.

5.4.2 Spiral Wrap Paper. This composite material and fabricating process go together. The composition can be varied to suit the application and the process is suitable to high volume applications (millions of containers). The 76 mm container used by the Army is made in this way and is cheaper (\$2-3) than any other alternative process or material found in this study. These containers are produced by a small number of specialized manufacturers. The process involves multi-material wrapping around a mandrel and utilizing the proper adhesives to form the basic tube. Crimping the stamped, cast or formed end pieces to the ends of the tube completes the manufacturing of the container. The soft tooling cost and 100 prototype containers was quoted at \$25,700. Hard tooling was quoted at an additional \$12,720 and unit container base production price quoted at \$12 in quantity, which does not consider design, development or tooling costs.

5.4.3 Fiberglass. Fiberglass manufacturers were reluctant to suggest methods of manufacturing containers which would best satisfy the requirements. The lowest quoted tooling cost was \$58,400 and unit

container cost was approximately \$35 not considering design, development and tooling costs. Further discussion with manufacturers indicated that tooling costs would probably run higher than the figure quoted, and produced no suggestions for optimizing the design. It was indicated that fiberglass tubing was difficult and expensive to manufacture, probably requiring a pulltrusion, which is a specialized technique, resulting in increased cost. Tubing is apparently not a suitable application for manufacturing and utilizing the advantages of the unique properties of fiberglass.

5.4.4 Steel. Two manufacturing methods for steel were investigated. First the development of an AN can was checked. This design is not best suited for this application unless extensive changes are made to suit ammunition handling such as accessible end cover removal while stacked in cord wood fashion. Secondly, a disposable "tin can" was checked into. Tooling required is several hundred thousand dollars, which makes it suitable only for applications with production quantities in the multi-millions. Tooling for forming steel must be heavy duty, requiring larger machinery, special alloys, etc., much more than the tooling required for aluminum. The lighter weight, easier forming and corrosion resistance of aluminum make it a more attractive alternative than steel.

5.4.5 Molded Polystyrene. A single mold and inlet steam ports are all that is required to produce polystyrene containers. The application of an ABS overcoat is accomplished by applying heat to a vacuum mold to which the ABS sheet is applied. The sheet shrinks to a smooth fit as it cools and forms a flexible yet tough finish. It is estimated that a tooling cost of \$3,000 is required to mold the polystyrene container, but the bulk size of the container, the disposal problem, susceptibility to handling damage, and the extra cost involved in overcoating the material eliminates this material from further consideration.

5.4.6 Polyethylene. This material can be injection molded, blow molded or rotationally molded. Tooling costs were estimated to be \$10,000 for injection molding and \$5,000 for roto molding. The manufacturing costs are reasonable and the process lend themselves well to the production of a container. Unfortunately, the physical limitations of polyethylene as previously noted make polyethylene unsuitable for a 76 mm container.

5.5 Recommendations on 76 mm Containers Based on Materials, Manufacturing Processes, Costs and Limited Environmental Tests. Based on the results of the study program, the following summary and recommendations for a 76 mm container is provided in overall order of preference: The aluminum container rates number one as the standard of comparison for all container materials based on its historical satisfactory performance and wide usage for cartridge and propellant charge tanks of all sizes. The fabricated manufacturing process is the least expensive aluminum manufacturing process in comparison to casting, forming, and deep draw methods. Unit container costs were among the lowest of all

the alternates. No environmental tests were conducted on this type of container since its properties are known to be satisfactory and only the design requires proofing for strength and handling requirements.

The spiral wrap paper container ranks second in overall preference. The composite material can be tailored to obtain the required characteristics. The manufacturing process is the basis for this type of container and is a very rapid method for producing large quantities of containers on semi-automatic machinery. For this reason production costs should enable this type of container to be the lowest cost of all alternates. Limited environmental tests indicated that this type of container should be satisfactory although not as durable as the aluminum container.

Fiberglass material was found to have excellent material properties, i.e., high strength. Manufacturing processes were not found suitable for making this style of container. Unit costs were the second highest of the container alternates considered. Limited environmental tests indicated that fiberglass would meet the most severe requirements. Because of the high costs for this particular application, fiberglass was not considered to be a viable candidate.

Steel ranked in the middle of the candidates. The material properties are satisfactory except for corrosion resistance. A variety of manufacturing processes are available to produce a steel container. Unit costs are reasonable even with the high tooling costs and steel containers have been used in the past, but replaced by aluminum for cartridge and propellant changes. Steel is felt to be inferior to aluminum in overall order of preference.

Molded polystyrene material has some unique properties which make it attractive. Manufacturing a container from this material is simple and inexpensive. Limited environmental tests were successful. The disadvantage of polystyrene is in its large bulk size in comparison to the other alternates. This eliminated this material from further consideration as an alternate container.

Polyethylene unfortunately rates in last place in this comparison. The material has some desirable qualities, manufacturing processes available are lower cost than most of the alternates and suitable for large production runs. Unit container costs would be among the lowest considered. The limited environmental testing disqualified polyethylene because of low temperature fragility.

6. LIFE CYCLE COST

Life cycle model and life cycle cost development are included as Appendixes A and B to this report. From this data the results were utilized in preparing the charts used in this section and the explanation thereof.

6.1 Life Cycle Cost for Container Types. There were three basic container types chosen for life cycle cost comparison. The reusable container has a recovery rate of 80% based on SPCC historical records, therefore, it can be issued five times during its lifetime before it is "lost" to the system. The semi-recoverable container has a recoverability rate of 50% based on the limited durability of the container. Some of those returned will be beyond repair, and be scrapped. The throwaway container has a one time use or a recoverability rate of 0%. It is only necessary to estimate the recoverability rate of a container into one of these three types and the unit container cost to determine the expected life cycle cost of the container.

6.1.1 Reusable Container Life Cycle Cost. From the life cycle cost model it is found that 461,308 containers must be procured and that 1,249,769 containers must be renovated and reissued during the period of the program (1977-2010). It is apparent that renovation costs are a significant portion of life cycle costs. It is assumed that a reasonable estimate of renovation cost is equal to 25% of the cost of procurement of a new container. Twenty percent and 30% figures were also used as renovation costs to show the sensitivity of renovation costs on life cycle costs.

Graph (Figure 5) indicates the total life cycle cost expected once the unit container cost has been determined. The linear dashed line indicates the procurement portion of life cycle cost. The solid lines indicate the total life cycle cost for comparison purposes including the renovation costs expressed as a percentage of procurement cost.

6.1.2 Semi-Recoverable Container Life Cycle Cost. From the life cycle cost model it is found that 930,199 containers must be procured and that 781,483 containers must be renovated and reissued for the period considered (1977-2010). For semi-recoverable containers it is assumed that a reasonable estimate of renovation cost is equal to 15% of the cost of procurement of a new container. Renovation costs are expected to be a lower percentage of cost on this container than on a reusable container since only slightly damaged containers will be repaired and the more heavily damaged containers will be replaced by new procurement. Heavily damaged containers (squashed, crumpled, ripped or battered) are too expensive or impossible to repair. Ten percent and 20% figures were also used as renovation costs to show the sensitivity of renovation costs on life cycle costs.

Graph (Figure 6) indicates the total life cycle cost expected once the unit container cost has been determined. The linear dashed line indicates the procurement portion of life cycle cost. The solid lines indicate the total life cycle cost for comparison purposes including the renovation costs expressed as a percentage of procurement cost.

6.1.3 Throwaway Container Life Cycle Cost. From the life cycle cost model it is found that 1,656,682 disposable containers must be procured, for the period considered (1977-2010). Since the throwaway con-

NUMBER OF CONTAINERS PROCURED - 461,308
NUMBER OF CONTAINERS REFURBISHED - 1,249,769

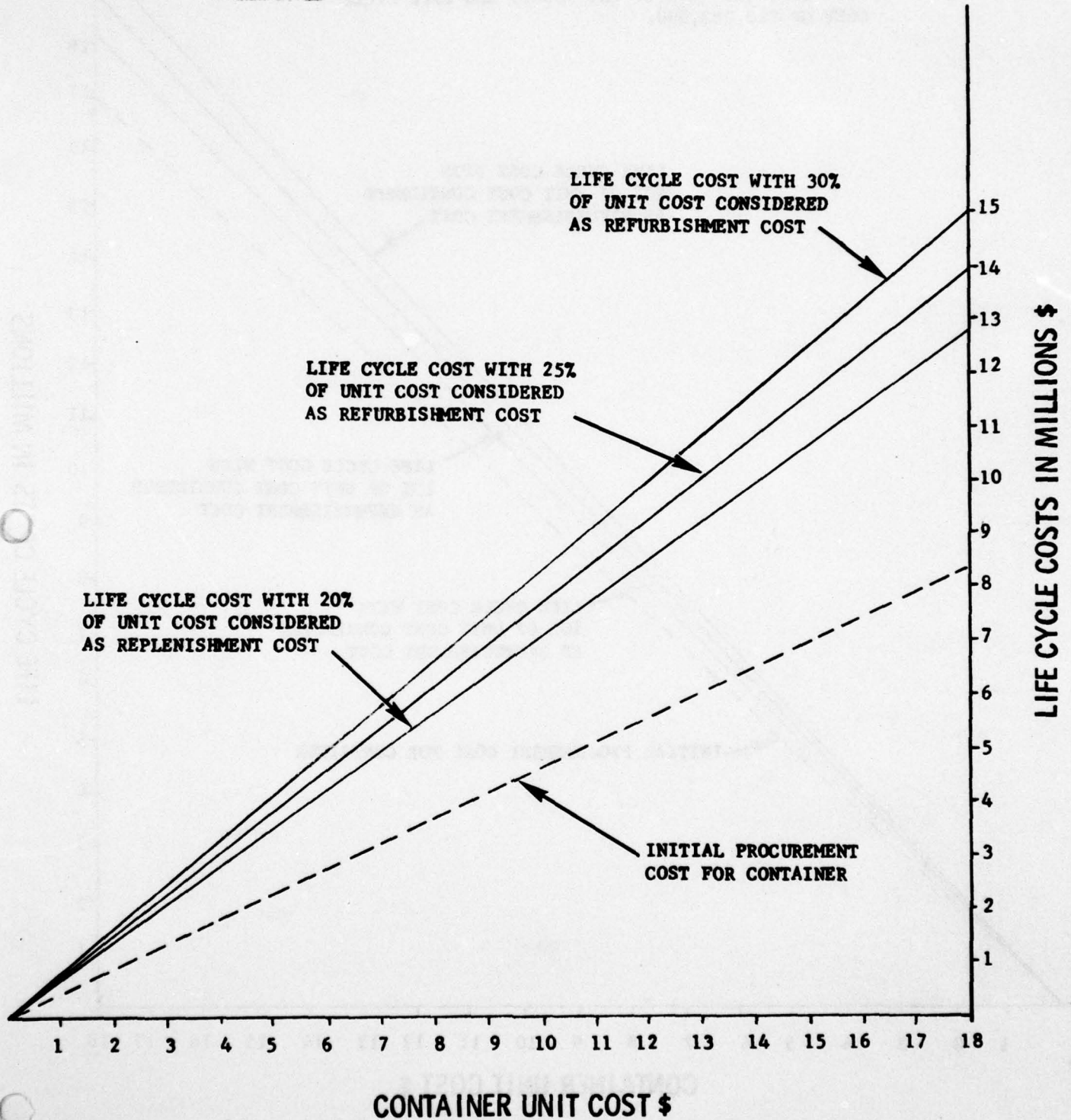

LIFE CYCLE COSTS FOR 80% REUSABLE CONTAINER

FIGURE 5

NUMBER OF CONTAINERS PROCURED - 930,199
NUMBER OF CONTAINERS REFURBISHED - 781,483

EXAMPLE: CONTAINER WITH \$10 UNIT COST AND REFURBISHMENT
COST OF \$1.00 (10% OF UNIT COST) HAS LIFE CYCLE
COST OF \$10,083,000.

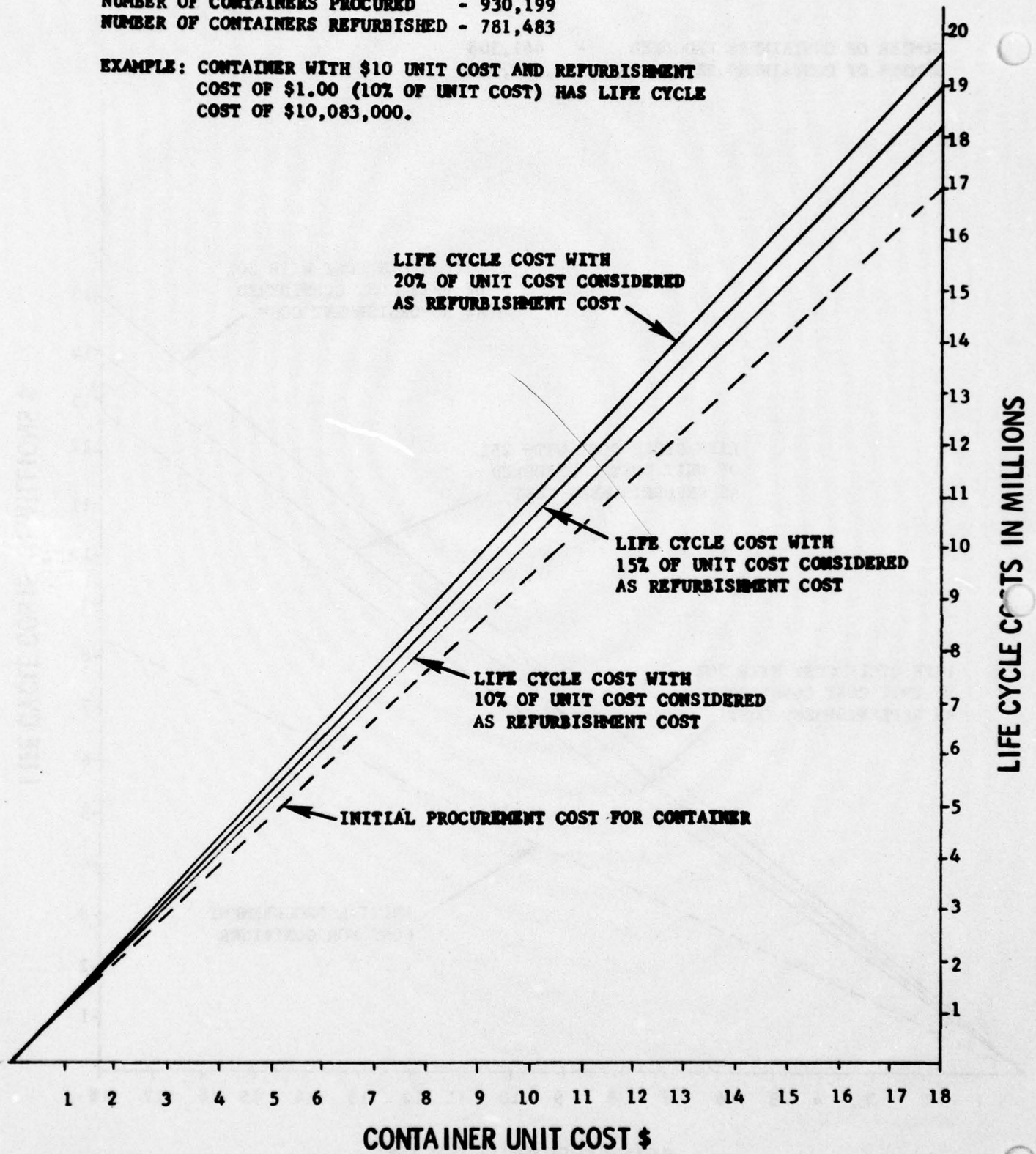

LIFE CYCLE COST FOR 50% RECOVERABLE CONTAINER

FIGURE 6

NUMBER OF CONTAINERS PROCURED - 1,656,602

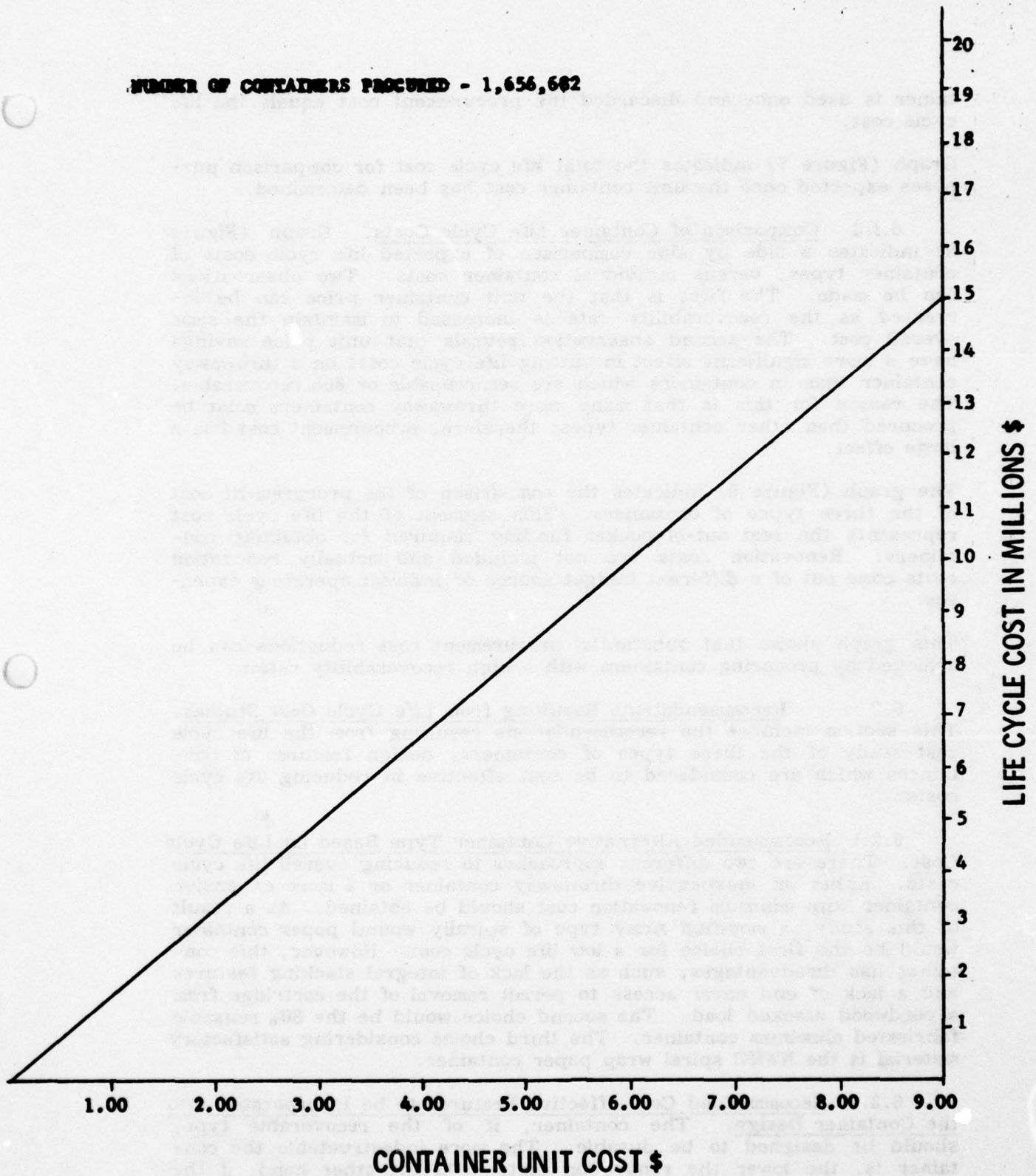

LIFE CYCLE COST FOR THROWAWAY CONTAINER

FIGURE 7
21

tainer is used once and discarded the procurement cost equals the life cycle cost.

Graph (Figure 7) indicates the total life cycle cost for comparison purposes expected once the unit container cost has been determined.

6.1.4 Comparison of Container Life Cycle Costs. Graph (Figure 8) indicates a side by side comparison of expected life cycle costs of container types, versus individual container costs. Two observations can be made. The first is that the unit container price can be increased as the recoverability rate is increased to maintain the same overall cost. The second observation reveals that unit price savings have a more significant effect in cutting life cycle costs on a throwaway container than in containers which are semireusable or 80% recoverable. The reason for this is that many more throwaway containers must be procured than other container types; therefore, procurement cost has a large effect.

The graph (Figure 9) indicates the comparison of the procurement cost of the three types of containers. This segment of the life cycle cost represents the real out-of-pocket funding required for obtaining containers. Renovation costs are not included and actually renovation costs come out of a different budget source or indirect operating expenses.

This graph shows that substantial procurement cost reductions can be achieved by procuring containers with a high recoverability rate.

6.2 Recommendations Resulting from Life Cycle Cost Studies. This section includes the recommendations resulting from the life cycle cost study of the three types of containers, design features of containers which are considered to be cost effective in reducing life cycle costs.

6.2.1 Recommended Alternative Container Type Based on Life Cycle Cost. There are two different approaches to reducing overall life cycle costs. Either an inexpensive throwaway container or a more expensive container with minimum renovation cost should be obtained. As a result of this study, a modified Army type of spirally wound paper container would be the first choice for a low life cycle cost. However, this container has disadvantages, such as the lack of integral stacking features and a lack of end cover access to permit removal of the cartridge from a cordwood stacked load. The second choice would be the 80% reusable fabricated aluminum container. The third choice considering satisfactory material is the NWHC spiral wrap paper container.

6.2.2 Recommended Cost Effective Features to be Incorporated into the Container Design. The container, if of the recoverable type, should be designed to be durable. The more indestructible the container is, the lower the renovation costs. On the other hand, if the container is of the disposable type, minimum procurement cost is the prime goal in obtaining the lowest life cycle costs. In this case the

EXAMPLE: FOR 10 MILLION IN LIFE CYCLE COST
THE FOLLOWING CHOICE IS AVAILABLE

- \$6 THROWAWAY CONTAINER
- \$9.50 50% RECOVERABLE CONTAINER
- \$13.00 80% RECOVERABLE CONTAINER

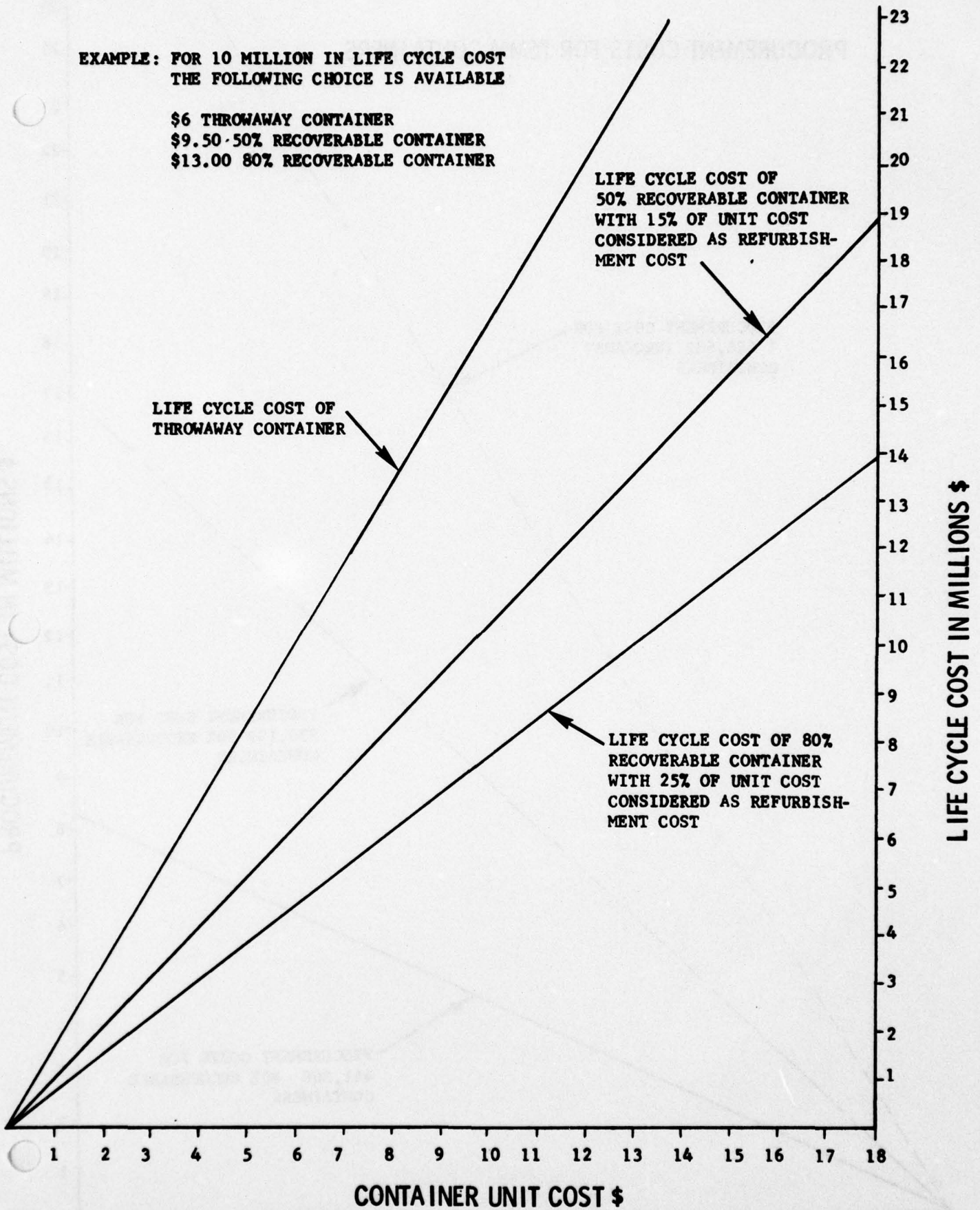

LIFE CYCLE COST FOR THREE BASIC TYPES OF CONTAINERS

PROCUREMENT COSTS FOR 76MM CONTAINERS

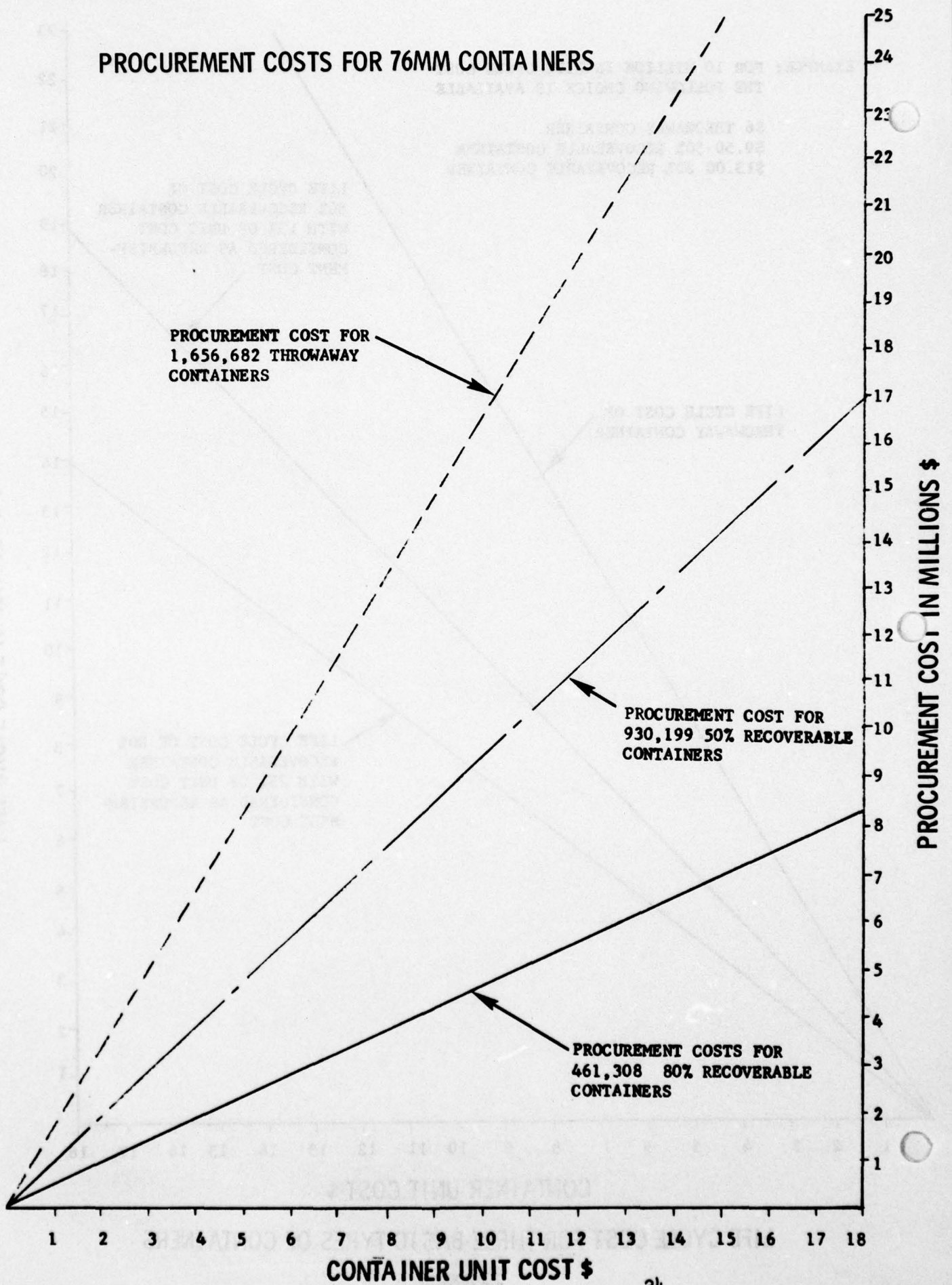

CONTAINER UNIT COST \$

PROCUREMENT COST IN MILLIONS \$

FIGURE 9

minimum features, minimum strength etc., should be the objectives in obtaining lowest costs.

6.2.3 Container Procurement Quantity Recommendations Based on Life Cycle Costs. The graph (Figure 10) unit cost of 76 mm container versus quantity procured shows the decrease in unit cost caused by the production quantity increase. This chart assumes that the production tooling is amortized over the production run of containers. The unit cost drops rapidly for a production run up to 10,000 containers, to a slight drop from 10,000 to 30,000 and remains relatively flat from this quantity upwards. It might be possible through incurring higher initial tooling costs to reduce container assembly labor costs which would enable the price to drop further per container for larger production runs. Graph (Figure 11) is titled "Cumulative Procurement Quantity Necessary to Meet Requirements During the Life of the Program." This chart indicates the total cumulative quantity required for each type of container and also the year in which the quantity of containers are required. It is possible by utilizing this chart to adjust the production rate and schedule to the most efficient level for the life of the program, and thereby obtain the lowest unit prices for containers.

7. RECOMMENDED PROTOTYPE 76 MM CONTAINERS

As a result of the study program, two containers were found to merit further development in a proposed prototype program. This section briefly describes the containers with the salient points on the suitability of each container in replacing the 3"/70 MK II container. Figure 12 indicates the major features of the container.

7.1 Spiral Wrap Container. This type of container is manufactured from combined layers of paper, foil and plastic material in a variety of combinations to provide the required characteristics. One sample container supplied by a manufacturer had a flame resisting chip board paper core with a spiral wrap aluminum foil interior skin and an exterior skin of polyethylene and aluminum foil spiral wrap. A second sample was the same except for the exterior which had the aluminum foil covered by polyethylene. Both containers had thin stamped metal ends which were secured to the tube by a single crimp. Telescoping end caps sealed with 2 inch wide tape closed the containers (13). A quote was obtained for this type of container which was the lowest cost of any container. Tooling cost would amount to an estimated \$8,200 with unit cost of \$9.51 for a quantity of 1,000 and \$4.16 for a quantity of 5,000. This indicates the potentially low cost of the manufacturing process. A throwaway type of container costing \$4.16 each would have the lowest life cycle cost of any container included by this study (\$6.9 million from Figure 7). The limited environmental test indicated that dents caused by handling damage could cause leaks, ending their useful service life.

(13) Memorandum WH-8051-JRB of 21 Jul 75 (enclosed in Appendix C)

UNIT COST OF 76 MM CONTAINER VERSUS QUANTITY PROCURED

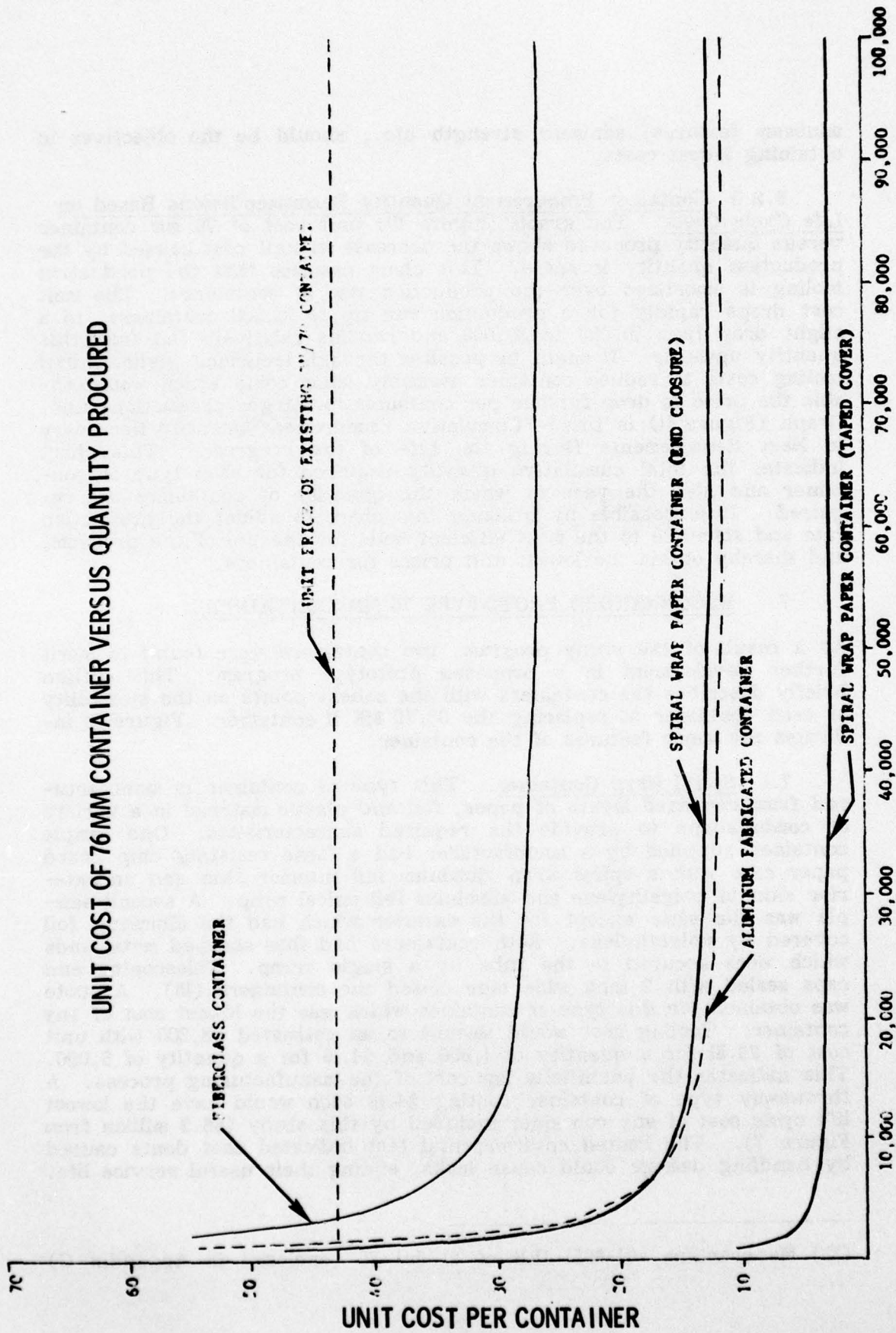

PROCUREMENT QUANTITY

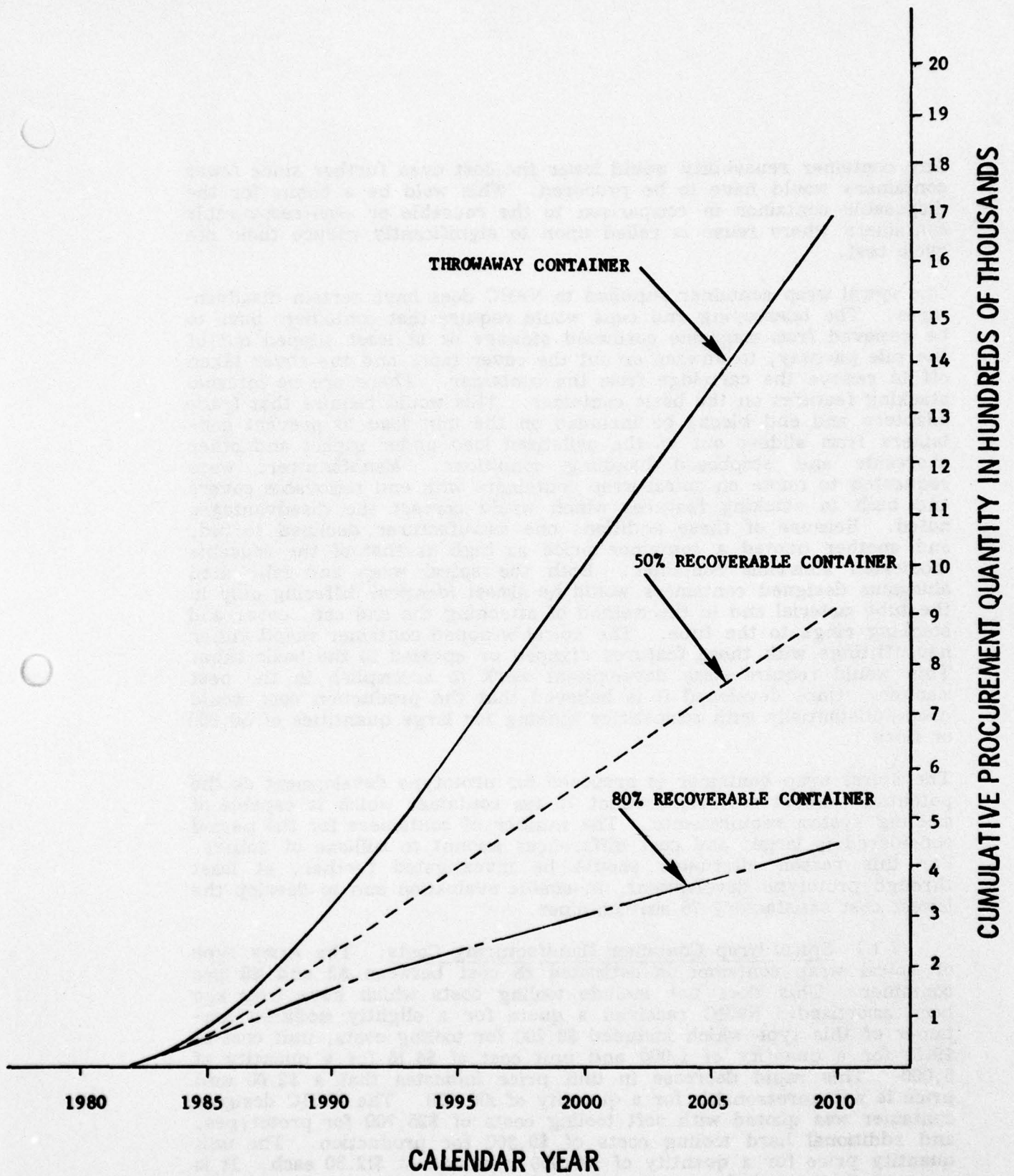

CUMULATIVE PROCUREMENT QUANTITY NECESSARY TO MEET REQUIREMENTS DURING LIFE OF PROGRAM NEGLECTING SUPPLY FOR STOCK

FIGURE 11

Any container reusability would lower the cost even further since fewer containers would have to be procured. This would be a bonus for the disposable container in comparison to the reusable or semi-recoverable containers where reuse is relied upon to significantly reduce their life cycle cost.

The spiral wrap container supplied to NWHC does have certain disadvantages. The telescoping end caps would require that containers have to be removed from magazine cordwood stowage or at least slipped out of the pile partway, to unwrap or cut the cover tape, and the cover taken off to remove the cartridge from the container. There are no internal stacking features on the basic container. This would require that frame adapters and end blocks be included on the unit load to prevent containers from sliding out of the palletized load under impact and other shoreside and shipboard handling conditions. Manufacturers were requested to quote on spiral wrap containers with end removable covers and built in stacking features which would correct the disadvantages noted. Because of these additions one manufacturer declined to bid, and another quoted a container price as high as that of the reusable fabricated aluminum container. Both the spiral wrap and fabricated aluminum designed containers would be almost identical differing only in the tube material and in the method of attaching the end cap, cover and stacking rings to the tube. The spiral wrapped container would either have fittings with these features crimped or epoxied to the basic tube. This would require some development work to accomplish in the best manner. Once developed it is believed that the production cost would drop substantially with competitive bidding for large quantities of 50,000 or more.

The spiral wrap container is proposed for prototype development as the potentially lowest cost replacement 76 mm container which is capable of meeting system requirements. The number of containers for the period considered is large, and cost differences amount to millions of dollars. For this reason alternates should be investigated further, at least through prototype development, to enable evaluation and to develop the lowest cost satisfactory 76 mm container.

7.1.1 Spiral Wrap Container Manufacturing Costs. The Army type of spiral wrap container is estimated to cost between \$2 and \$5 per container. This does not include tooling costs which have long ago been amortized. NWHC received a quote for a slightly modified container of this type which included \$8,200 for tooling costs, unit cost of \$9.51 for a quantity of 1,000 and unit cost of \$4.16 for a quantity of 5,000. This rapid decrease in unit price indicates that a \$2.00 unit price is not unreasonable for a quantity of 100,000. The NWHC designed container was quoted with soft tooling costs of \$25,700 for prototypes, and additional hard tooling costs of \$9,300 for production. The unit quantity price for a quantity of 100,000 remained at \$12.50 each. It is assumed that a spiral wrap container of NWHC design could be obtained for a midpoint price of \$7.25 (between the \$2 and \$12.50 price); however, there are no hard figures to justify this assumption.

7.1.2 Spiral Wrap Container Life Cycle Cost. The mid-range life cycle cost for the spiral wrap container proposed by NWHC was found to be \$17.0 million from Figure 4 with a unit container price of \$16.25. This mid-range price was used to compare costs for low and high production quantities for each alternate container type in the most reasonable manner.

The life cycle cost for a spiral wrap container for a high production quantity (100,000) with a unit price of \$12.35 (\$12 base price + \$35,000 tooling) is estimated for a 50% recoverable container and for a throwaway container. Development program costs are not considered as they apply approximately the same for each alternate container. From Figure 8 the life cycle comparison costs are:

50% Recoverable Container	-	\$12.9 million
Throwaway Container	-	\$20.6 million

It is expected that the spiral wrap container will be 50% recoverable; therefore, the most likely life cycle cost will be \$12.9 million. If, however, the durability is found to be less than expected, during the prototype development program, the life cycle cost would increase to a worst case condition of 0% recoverability with a life cycle cost of \$20.6 million.

Assuming that a spiral wrap container could be obtained for a unit price of \$7.60 (7.25 base price + \$35,000 tooling) as indicated in paragraph 7.1.1 the life cycle comparison costs would be reduced to the following, again from Figure 8:

50% Recoverable Container	-	\$8.0 million
Throwaway Container	-	\$12.6 million

These life cycle costs for the spiral wrap container compare closely with the aluminum fabricated container. They also represent very real and substantial life cycle cost savings in comparison to the \$32.7 million life cycle cost involved if new procurement of 3"/70 MK II containers were initiated for the entire program requirements.

7.2 Aluminum Fabricated Containers. Aluminum has been the basic material used in the manufacture of tasks and containers for Naval Ordnance items, replacing steel containers several years ago. A variety of manufacturing processes has been used for producing aluminum containers, although containers have not been procured since World War II when one container was supplied for each cartridge and propellant charge manufactured. For this study program the lowest cost aluminum manufacturing method was investigated, as the "standard" of comparison for all alternate container designs.

Aluminum fabricated containers appear at this time to be the container with the least risk in development which would meet the program requirements. Stock aluminum tubing is available which would be the basic con-

tainer. End caps, covers, and stacking features of stamped or impact forms require development along with the methods for attachment to the aluminum tube by forming, rolling, welding or other means.

7.2.1 Aluminum Fabricated Container Manufacturing Costs. The soft tooling costs of approximately \$10,000 and production tooling of additional \$29,000 and unit base price of \$11.75 is considered to be the least expensive aluminum container available.

7.2.2 Aluminum Fabricated Container Life Cycle Cost. The mid-range life cycle cost for the aluminum fabricated container was found to be \$12.4 million from Figure 4 with a unit container price of \$16. This mid-range price was used to compare costs for low and high production quantities for each alternate container type in the most reasonable manner.

The life cycle costs for an aluminum fabricated container for a high production quantity (100,000) with a unit price of \$12.14 (\$11.75 base price + \$39,000 tooling) is estimated for an 80% recoverable container. Development program costs are not considered as they apply approximately the same for each alternate container. From Figure 8 the life cycle cost comparison figures are:

80% Reusable Container	-	\$9.4 million
50% Recoverable Container	-	\$12.7 million

It is expected that the aluminum fabricated container will be 80% reusable; therefore, the most likely life cycle costs will be \$9.4 million. If, however, the durability is found to be less than expected, during the prototype development program, the life cycle costs would be \$12.7 million.

These life cycle costs like the spiral wrap container, represent very real and substantial life cycle cost savings in comparison to the \$32.7 million life cycle cost involved if new procurement of 3"/70 MK II containers were initiated for the entire program requirements.

7.3 Recommendations for Prototype Container. Based on the presently known facts the aluminum fabricated container appears to be the best overall alternate container choice. It is felt that at this point the spiral wrap paper container should not be eliminated from further evaluation. A side by side comparison and evaluation of prototypes of both types of containers would be advantageous. The higher indicated life cycle costs of the spiral wrap container may well be substantially reduced as shown in 7.1.2 once the design has been developed and the production efficiency of the spiral wrap process is realized. The durability of both candidates must also be determined. The recoverability rate affects the life cycle costs, and should the spiral wrap prove to be as durable as aluminum (50% recoverable), the life cycle cost would then be lower for the spiral wrap container. The large number of containers involved in the 76 mm program and high program costs appear to justify backup insurance and proof, available only through prototype tests, that the container finally selected is truly the best container available.

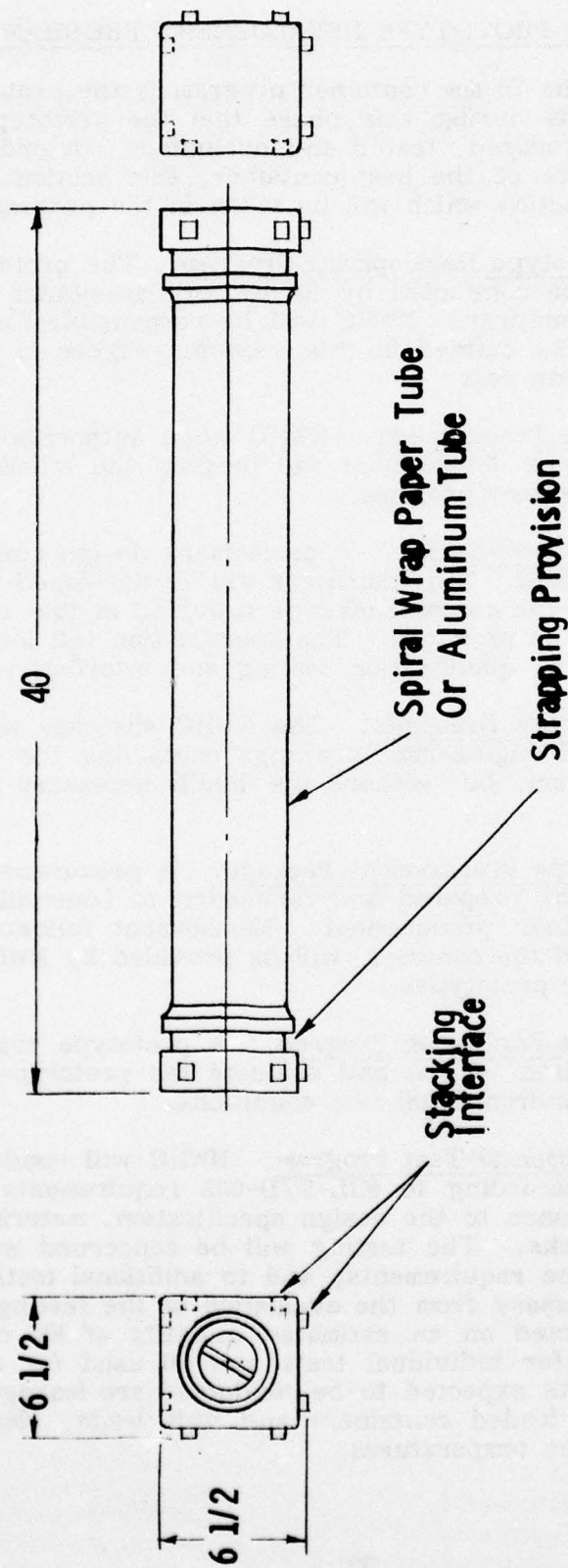

76mm Cartridge Container

Fig. 12.

8. PLAN FOR PROTOTYPE DEVELOPMENT PROGRAM

The next phase of the 76 mm container program is the prototype development program. It is during this phase that the prototype containers will be designed, procured, tested and evaluated. In order to recommend the final choice of the best container, this section provides the plan and course of action which will be taken in the program.

8.1 NWHC Prototype Development Program. The prototype development program will be conducted by NWHC with assistance provided by the container manufacturer. NWHC will be responsible for the accomplishment of the tasks defined in this section. Figure 13 provides the prototype schedule and cost.

8.1.1 Prototype Procurement. NWHC when authorized and funded to undertake prototype development will perform the following tasks to carry out the development program.

8.1.1.1 Design Specification. A preliminary design specification was prepared in August 1976. This document will be developed into a detailed specification from the recommendations provided in this report and the type of container to be procured. The specification will include the requirements for design, qualification testing and interface requirements.

8.1.1.2 Preliminary Drawings. The NWHC sketches will be transferred into Level III engineering drawings containing the basic dimensions and configuration, but without the details necessary for manufacture.

8.1.1.3 Prototype Procurement Package. A procurement documentation package will be prepared and forwarded to Louisville, Kentucky for prototype container procurement. Management followup, with the manufacturer awarded the contract, will be provided by NWHC to achieve the desired container prototypes.

8.1.2 Prototype Evaluation Program. A prototype evaluation program will be conducted to test and evaluate the prototype design and performance under environmental test conditions.

8.1.2.1 Environmental Test Program. NWHC will conduct a prototype test program according to MIL-STD-648 requirements to evaluate the degree of compliance to the design specification, material suitability and dimensional checks. The testing will be concerned with the most severe portions of the requirements, and to additional testing that may be indicated as necessary from the evaluation of the testing conducted. Tests will be conducted on an estimated quantity of 106 containers of each type, 10 used for individual tests and 96 used for two complete unit loads. The tests expected to be conducted are leakage test, drop and impact tests of loaded containers and unit loads, along with low order shock at various temperatures.

A prototype evaluation report will be prepared which will contain the results, conclusions and recommendations reached a result of prototype evaluations. If more than one prototype design is evaluated, recommendations will be provided as to which should be selected as the 76 mm container.

8.2 Manufacturers Prototype Program. The manufacturer will be responsible for the design and manufacturing drawings of all detail container assembly components subject to NWHC drawing approval authority, and the tooling and fixtures required in their manufacture.

8.2.2 Fixtures and Soft Tooling. The manufacturer will be responsible for the development and manufacturing of all special tools and fixtures required to produce the prototype container.

8.2.3 Manufacturer of Prototype Container. The container manufacturer will submit the required number of prototype containers to NWHC for test and evaluation.

FIGURE 13. PROGRAM SCHEDULE AND COST 76 MM PROTOTYPE CONTAINER

WEEKS	2	4	6	8	10	12	14	16	18	20	22	24	26	28	30	32	34	36	38	40	42	44	46	48	50	52	54	56	58	60	62	64	66	68	<u>Cost</u>
NWHC Design																													\$10,980						
Prototype Acquisition Mgmt.																													\$ 4,514						
Prototype Manufacture																													\$40,850						
First Article Test																													\$ 5,368						
Evaluation Report																													\$ 7,076						
Upgrade Design & Retest (as req'd)																													\$12,444						
Class I Documentation																													\$25,620						
																													<u>TOTAL</u>						
																													<u>\$106,852</u>						

APPENDIX A

LIFE CYCLE MODEL

A life cycle model for the 76 mm container was developed. The model was designed to determine the factors involved in the life cycle cost for each type of container, so that realistic comparisons could be made between the available container types. The goal of the model is to determine the number of containers required of each container type for the entire program period.

The assumptions provided by NAVSEA letter 06G3/GSM 8021 Ser 7 dated 10 January 1977 (enclosed) were the basis for the life cycle model of the 76 mm ammunition program. Other assumptions and simplifications were made as necessary to complete the life cycle model.

The following additional assumptions were made:

It is assumed that the present 3"/70 MK II Tank will be fully utilized for the entire period of the program from 1977 through 2010. This means that the RFI existing supply will be issued as necessary. Eighty percent of the MK II Tanks presently in unserviceable condition will be renovated and issued as required. The recoverability rate of the present tank is assumed to remain at 80% so that for each 100 tanks issued, 80 will be returned, renovated and reissued.

76 mm container types were chosen to be either 80% reusable, 50% semi recoverable, or 0% recoverable - throwaway containers.

It is assumed that supply demands in excess of this existing supply of MK II tanks each year will be satisfied by timely procurement of the proposed 76 mm tank.

The MK II container and 76 mm container population mix is assumed to be directly proportional to the number of each container type in the system, and issues made are made up of both container types.

All ships are assumed to be capable of stowage of both container types in any proportion.

Ships are assumed to receive mixed loads of both containers in proportion to their percentage in the total population. Noncompatibility of pallet loads is not considered.

It is assumed that a FIFO (First In First Out) system is used in issuing, expending and retrograde of ammunition. This inventory method maintains the mix of containers of each type consistently proportional to the total population.

It is also assumed that the RFI stock supply will be a six month supply or a quantity which will build up eventually to a RFI supply of

25,000 tanks. These 25,000 tanks are a one time procurement quantity which can be procured as required during the program to maintain six months of issues in stock. These 25,000 tanks are necessary no matter which type of container is procured. This quantity may be adjusted as required without affecting the issue and return calculations in any fashion, but does affect the total life cycle cost, because of the procurement of this additional quantity of containers.

Tanks with expended rounds which are returned during one calendar year are assumed to be renovated and available for reissue at the beginning of the following year.

Offloads of live ammunition from ships entering overhaul during the year are expected to be refinished and available for reissue at the beginning of the following year.

Initial ships outfitting requirements are assumed to be satisfied at the beginning of the year in which the ship is commissioned.

Each operating ship is assumed to maintain its full allowance for the entire operating period.

Each ship is assumed to return for overhaul at the beginning of the fifth year, offload its full allowance of ammunition and complete its overhaul and enter service at the beginning of the sixth year with its full onboard allowance. Four year full operating periods are considered thereafter.

It was found that the following number of containers of each type must be procured during the period from 1982 through 2010 to satisfy the system demands:

80% Reusable Container	461,308
50% Recoverable Container	930,199
0% Recoverable Throwaway Container	1,656,682

It was also found that the following number of containers requiring renovation for the period to satisfy the assumptions made were:

80% Resuable Container	1,249,769
50% Recoverable Container	781,483
0% Recoverable	0

	YEAR	1977	1978	1979
<u>INITIAL ALLOWANCE</u>				
(A) # 400 ROUND SHIPS COMMISSIONED (1.66 SHIPS/YR)				2
(B) # 76 MM ROUNDS ISSUED FOR INITIAL ALLOWANCE				80
(C) # 600 ROUND SHIPS COMMISSIONED (10 SHIPS/YR)				10
(D) # 76 MM ROUND ISSUED FOR INITIAL ALLOWANCE				60
(E) TOTAL INITIAL ALLOWANCE ((B) + (D))				680
(F) CUMULATIVE ALLOWANCE (FIELD POPULATION) (Σ (E))				68
<u>ALLOWANCE AFTER OVERHAUL</u>				
(G) # 400 ROUND SHIPS COMPLETING OVERHAUL				
(H) # 76 MM ROUNDS ISSUED AFTER OVERHAUL				
(J) # 600 ROUND SHIPS COMPLETING OVERHAUL				
(K) # 76 MM ROUNDS ISSUED AFTER OVERHAUL				
(L) TOTAL ALLOWANCE AFTER OVERHAUL ((H)+(K))				
(M) CUMULATIVE ALLOWANCE AFTER OVERHAUL (Σ (L))				
(N) TOTAL ALLOWANCE REQUIREMENT ((E)+(L))				60
<u>REPLENISHMENT REQUIREMENTS</u>				
(P) TOTAL # COMMISSIONED SHIPS ((A) + (C))				1
(Q) # SHIPS ON OVERHAUL				
(R) # ACTIVE SHIPS ((P) - (Q))				1
(S) # REPLENISHMENT ROUNDS REQD $\left(\frac{50,000 \text{ rounds}}{105 \text{ ships}} \times (R) \right)$				57
(T) TOTAL 76 MM ROUNDS ISSUED EACH YEAR ((N) + (S))				12

**LOGISTIC REQUIREMENTS 76MM SHIP
LIFE CYCLE MODEL**

1979	1980	1981	1982	1983	1984	1985	1986	1987	1988	1989	1990
2	4	5	7	9	10	12	14	15	17	19	20
800	800	400	800	800	400	800	800	400	800	800	400
10	20	30	40	50	60	70	80	90	100	110	120
6000	—————→										
6800	6800	6400	6800	6800	6400	6800	6800	6400	6800	6800	6400
6800	13600	20000	26800	33600	40000	46800	53600	60000	66800	73600	80000
					2	2	1	2	4	3	3
					800	800	400	800	1600	1200	1200
					10	10	10	10	20	20	20
					5000	—————			12000	—————	
					6800	6800	6400	6800	13600	13200	13200
					6800	13600	20000	26800	40400	53600	66800
6800	6800	6400	6800	6800	13200	13600	13200	13200	20400	20000	19600
12	24	35	47	59	70	82	94	105	117	129	140
				12	12	11	12	23	23	23	24
12	24	35	47	47	58	71	82	82	94	106	116
5712	11424	16660	22372	22372	27608	33796	39032	39032	44744	50476	55216
12512	18224	23060	29172	29172	40809	47396	52232	51756	65144	70456	74816

SHIP REQUIREMENTS

MODEL

	1991	1992	1993	1994	1995	1996	1997	1998	1999	2000	2001	2002
	4	5										
	1600	2000										
	20	30										
		18000										
	13600	20000										
	80400	100400	120400	140400	160400	180400	200400	220400	240400	260400	280400	300400

	YEAR	1977	1978	1979	1980	1981	1982
AA - NECESSARY PROCUREMENT OF 0% RECOVERABLE CONTAINER TO MEET ISSUE REQT'S (9) FROM 3"/70 MK 11 CONTAINER REQUIREMENTS)							75
AB - TOTAL PROCUREMENT REQD OF 0% RECOVERABLE CONTAINER (Σ AA) = 1,656,682							75
AC - TOTAL # AVAILABLE CONTAINERS BOTH TYPES FROM PREVIOUS YEARS OFFLOADS (17)					5712	11424	16
AD - % OF ALTERNATE CONTAINERS CONTAINERS RETURNED OUT OF TOTAL RETURNED (100% - (2))					0	0	
AE - TOTAL # ALTERNATE CONTAINERS RETURNED (AC X AD)							
AF - # ALTERNATE CONTAINERS AVAILABLE WITH 80% REUSABILITY RATE (.8 X AE)							
AG - # ALTERNATE CONTAINERS TO BE PROCURED EACH YEAR WITH 80% REUSABILITY RATE (AA - AF)							75
AH - TOTAL PROCUREMENT REQ'D OF 80% REUSABLE CONTAINERS (Σ AG) - <u>436,308</u>							75
AJ - # ALTERNATE CONTAINERS AVAILABLE WITH 50% REUSABILITY RATE (.5 X AE)							
AK - # ALTERNATE CONTAINERS TO BE PROCURED EACH YEAR WITH 50% REUSABILITY RATE (AA - AJ)							75
AL - TOTAL PROCUREMENT REQ'D OF 50% REUSABLE CONTAINERS (Σ AK) - <u>905199</u>							75

LOGISTIC REQUIREMENTS

**76 MM ALTERNATE CONTAINER REQU
LIFE CYCLE MODEL**

1982	1983	1984	1985	1986	1987	1988	1989	1990	1991	1992	1993
7911	13803	24379	32532	38244	38557	51793	59659	66210	56350	62871	64791
7911	21714	46093	78625	116869	155426	207219	266875	333085	389435	452306	517097
16660	23372	29172	34408	40196	45832	52156	57944	63656	68816	69980	
0	17.8	29.6	46	56.5	64	68	77.7	83.1	86.9	87.3	90.73
	4160	8634	15827	22710	29332	35466	45022	52898	59801	61092	63492
	3328	6907	12661	18168	23465	28372	36017	42318	47840	48873	50793
7911	10475	17472	19871	20076	15092	23421	23639	23892	8510	13998	
7911	18386	35858	55729	75805	90897	114318	137957	161849	170359	194357	198355
	2080	4317	7913	11355	14666	17733	22511	26449	29900	30546	31746
7911	11723	20062	24619	26889	23891	34060	37145	39761	26450	32325	33045
7911	19634	39696	64315	91204	115095	149155	186300	226061	252511	284836	317881

REQUIREMENTS

1993	1994	1995	1996	1997	1998	1999	2000	2001	2002	2003	2004
4791	65871	66700	67355	67881	68301	68637	68906	69118	69292	69425	69536
17097	582968	649668	717023	784904	853205	921842	990748	1059866	1129158	1198583	1268119

0.73	92.66	94.14	95.31	96.25	97	97.6	98.08	98.46	98.77	99.008	99.206
3492	64843	65879	66697	67355	67880	68300	68636	68912	69119	69285	69424
0793	51874	52703	53357	53884	54304	54640	54908	55121	55295	55428	55539

98355	212352	226349	240347	254344	268341	282338	296336	310333	324330	338327	352324
01746	32421	32939	33348	33677	33940	34150	34318	34451	34559	34642	34712
33045	39450	33761	34007	34204	34361	34487	34588	34667	34733	34783	34824
17881	351331	385092	419099	453303	487664	522151	556739	591406	626139	660922	695746

2002	2003	2004	2005	2006	2007	2008	2009	2010
69292	69425	69536	69625	69695	69752	69798	69833	69860
129158	1198583	1268119	1337744	1407438	1477191	1516989	1586822	1656682

98.77	99.008	99.206	99.365	99.49	99.59	99.673	99.73	99.78
69119	69285	69424	69535	69623	69693	69751	69795	69829
55295	55428	55539	55628	55698	55794	55800	55836	55863

24330	338327	352324	366321	380318	394316	408314	432311	436308
34559	34642	34712	34767	34811	34846	34875	34897	34914
34733	34783	34824	34858	34884	34906	34923	34936	34946
26139	660922	695746	730604	765488	800394	835317	870253	905199

	YEAR	1977	1978	1979
①	TOTAL # AVAILABLE CONTAINERS FROM PREVIOUS YEARS OFF-LOADS			
②	% OF 3"/70 MK 11 CONTAINERS OF ALL AVAILABLE CONTAINERS (PREVIOUS YR ⑬)			
③	# 3"/70 MK 11 CONTAINERS AVAILABLE (① X ②)			
④	# 3"/70 MK 11 CONTAINERS AVAILABLE AFTER ATTRITION (80% OF ③)			
⑤	TOTAL # 3"/70 MK 11 CONTAINERS IN STOCK FROM PREVIOUS YEAR (PREVIOUS YEAR ⑧)			48
⑥	TOTAL # OF 3"/70 MK 11 CONTAINERS AVAILABLE FOR ISSUE (④ + ⑤)			48
⑦	CURRENT YEAR TOTAL ISSUES FROM SHIP REQUIREMENTS (T)			12
⑧	# 3"/70 MK 11 CONTAINERS IN STOCK AFTER CURRENT YEAR ISSUE (⑥ - ⑦ IF POS)		48020	35
⑨	NECESSARY ISSUES OF ALTERNATE CONTAINER TO MAKE BALANCE OF ISSUES (⑥ - ⑦ IF NEG)			0
⑩	ATTRITION - 20% OF 3"/70 MK 11 CONTAINERS RETURNED (20% OF ③)			
⑪	# 3"/70 MK 11 CONTAINERS AVAILABLE AT BEGINNING OF PRESENT YEAR (PREV YR ⑪ - PRES YR ⑩)			48
⑫	TOTAL POPULATION OF ALL CONTAINERS IN SYSTEM IN CURRENT YEAR (⑨ + ⑪)			48
⑬	% OF 3"/70 MK 11 CONTAINERS IN SYSTEM (⑪ ÷ ⑫)			10
⑭	OFF-LOADED FROM SHIPS ENTERING OVHL (Q X NO. ROUNDS ON ALLOWANCE)			
⑮	OFF-LOADED FROM EXPENDED ROUNDS (S)			57
⑯	TOTAL OFF-LOADS Σ ⑭ + ⑮			57
⑰	TOTAL RENOVATED CONTAINERS AVAILABLE FROM PREVIOUS YEAR OFF-LOADS (PREV YR ③)			

48020	35508	21854	7933	0								
48020	40078	30993	21261	15369	16429	14864	13988	13199	13351	10800	8606	
12512	18224	23060	29172	40808	47396	52232	51756	65144	70456	74816	63580	
35508	21854	7933	0									
0	0	0	7911	13803	24379	32532	38244	38557	51793	59656	66210	
	1142	2285	3332	3842	4107	3716	3497	3299	3337	2700	2151	
48020	46878	44593	36660	32818	28711	24995	21498	18199	14862	12162	10011	
48020	46878	44593	44571	46621	53090	57527	59742	56756	66655	71818	76221	
100	100	100	82.2	70.4	54	43.5	36	32	22.3	16.9	13.1	
				6800	6800	6400	6800	13600	13200	13200	13600	
5712	11424	16660	22372	22372	27608	33796	39032	38556	44744	50456	55216	
5712	11424	16660	22372	29172	34408	40196	45832	52156	57944	63656	68816	
		5712	11424	16660	22372	29172	34408	40196	45832	52156	57944	

70 MK 11 CONTAINER

DEL

	1991	1992	1993	1994	1995	1996	1997	1998	1999	2000	2001	2002
90	68816	69980										
656	68816	69980										
6.9	13.1	12.7	9.27	7.34	5.86	4.69	3.75	3	2.4	1.92	1.54	1.23
757	9038	8887	6487	5136	4100	3292	2624	2099	1679	1343	1077	860
106	7230	7109	5189	4109	3280	2625	2099	1679	1343	1074	862	688
106	7230	7109	5189	4109	3280	2625	2099	1679	1343	1074	862	688
580	69980											
210	56350	62871	64871	65871	66700	67355	67881	68301	68637	68906	69118	6929
151	1807	1777	1297	1027	820	656	524	419	335	268	215	172
011	8204	6427	5130	4103	3283	2627	2103	1684	1349	1081	866	694
221	64554	69298	69921	69974	69983	69982	69984	69985	69986	69987	69984	6998
1.1	12.7	9.27	7.34	5.86	4.69	3.75	3	2.4	1.92	1.54	1.23	.992
600	20000											
216	49980											
816	69980											
944	63656	68816	69980									

1999	2000	2001	2002	2003	2004	2005	2006	2007	2008	2009	2010
											→
2.4	1.92	1.54	1.23	.992	.794	.635	.51	.41	.327	.263	.215
1679	1343	1077	860	694	555	444	356	285	288	184	150
1343	1074	862	688	555	444	355	285	228	182	147	120
											→
1343	1074	862	688	555	444	355	285	228	182	147	120
											→
											→
68637	68906	69118	69292	69425	69536	69625	69695	69752	69798	69833	69860
335	268	215	172	138	111	88	71	57	45	36	30
1349	1081	866	694	556	445	357	286	229	184	148	118
69986	69987	69984	69986	69981	69981	69982	69981	69981	69982	69981	69978
1.92	1.54	1.23	.992	.794	.635	.51	.410	.327	.263	.215	.169
											→
											→
											→
											→
											→

4



DEPARTMENT OF THE NAVY
NAVAL SEA SYSTEMS COMMAND
WASHINGTON, D.C. 20362

IN REPLY REFER TO
06G3C/GSM
8021
Ser 7
10 Jan 1977

From: Commander, Naval Sea Systems Command
To: Commanding Officer, Naval Weapons Station Earle, Naval Weapons
Handling Center

Subj: Alternate Packaging for 76 mm Ammunition (u)

Ref: (a) WPNSTA Earle ltr WH-8025-SRP;jmh Ser 1400-76 of 29 Sept 1976

1. Reference (a) requested guidance, for economic tradeoff analysis purposes, of possible quantities of subject ammunition.
2. Assume that there is a pool of unmodified 3"/70 cartridge tanks made up as follows:
 - a. 6800 in condition code A
 - b. 52400 in condition code E (repairable)

Assume, further, that, since these containers have been in dead storage for many years, that the yield from refurbishing will be 80 percent.

3. Assume that, by 1990 there will be
 - a. 20 gun mounts @ 400 rounds/mount
 - b. 120 gun mounts @ 600 rounds/mount

Assume that, to fill allowances and provide for an appropriate reserve, production by 1990 will have totaled 220,000 rounds. Thereafter, assuming a peace time posture, production to support training will be at the rate of 50,000/year until the year 2010.

4. In the economic analysis, fully reusable, simply reclosable and non-reusable containers may be considered. In so doing, however, the economic analysis must consider, and trade off
 - a. Refurbishment costs
 - b. Replacement costs of non-reusable containers incident to RSS&I and ammunition exterior maintenance.



06G3C/GSM
8021
Ser 7

Subj: Alternate Packaging for 76 mm Ammunition (u)

5. To simplify this aspect of the analysis, make the following assumptions

- a. One mount per ship.
- b. Straight line introduction of ships beginning in 1979 and ending in 1990.
- c. Four years interval between overhauls, with the first beginning in 1983. Straight line introduction to overhaul.
- d. No emergency or other offloads between overhauls.
- e. No ammunition suspensions nor any up grade programs.

6. All figures and dates given are fictitious and do not represent firm plans or programs. Your report of the economic analysis may remain unclassified so long as the members are labeled as assumptions.

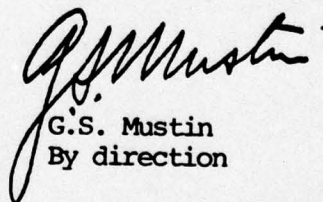
G.S. Mustin
By direction

APPENDIX B

LIFE CYCLE COSTS

The life cycle cost represents the total investment in 76 mm ammunition containers during the entire period of the program. This total is comprised of procurement costs and operating and support costs. The life cycle model was used to determine the total number of containers of each container type which are required during the period of the program (1978 through 2010). The model also developed the number of containers which must be renovated and reissued to minimize new procurement of containers.

The following assumptions were made to determine life cycle costs for each of the three types of containers.

The life cycle costs for the 3"/70 MK 11 tank were not included in the study since this tank is assumed to remain in the system no matter which alternate container is chosen.

The research and development costs are not included in the life cycle cost section. These costs are provided in the prototype development section of this report for the recommended alternate containers and are constant no matter which container is developed, therefore they do not affect comparison of costs between container alternates.

The procurement cost portion of the life cycle cost includes prototype and production tooling as well as procurement of approximately 110 prototype containers of each type. The prototype quantity is necessary to prove out the design and environmentally test two unit loads of containers with 10 additional containers for individual tests.

The operation and support portion of the container life cycle costs of the container were developed in the following manner. It is assumed that transportation, handling, stacking, stowage and retrograde costs will be the same for all types of containers. The number of renovations necessary will be dependent on the type of container, therefore, the more reusable the container, the more renovations will be required and less container procurement will be necessary to satisfy all system demands.

Renovation has for the most part been performed by the Ammunition Depots. NWS Yorktown performs renovation of 5"/54 MK 14 MOD 0 Tanks for \$4.50 and 3"/50 MK 5 Tank for \$4.00*. Contracts have been performed on tank renovations and modifications which involved installation of an extension sleeve from \$5 to \$6 per container. It was estimated that the renovation cost for a reusable container similar to existing containers should cost between 20 to 30% of the cost of the container, with the most probable cost of 25%. On a semi-reusable container it was es-

*Renovation Status Report for Conventional Ammunition dtd 31 Mar 77

timated that a lower renovation cost would result from selecting fewer of the best containers for renovation and discarding the remainder. Renovation is expected to cost from 10% to 20% of the cost of new semi-reusable container procurement with the most probable cost of 15%. For the throwaway containers there was no renovation cost considered, since after one use all containers are assumed to be discarded.

Graphs were made up to show the life cycle costs for each container type versus the unit container cost and unit renovation costs (as a percent of container cost) (Figures 5, 6 and 7). Another graph was made to compare the life cycle cost of the three container types including each types most probable renovation cost (Figure 8). From this chart rapid comparison of manufacturers quotes for different container types can be made and the lowest life cycle cost comparison figure can be selected.

Other life cycle cost factors may be considered separately if desired. The life cycle cost for supporting the MK II container throughout the period can be calculated, for example, also discount techniques can be used to make further comparisons. Discounts were calculated, but were not included in this report as no significant difference in relative costs were obtained for the three types of containers.

For the purpose of the 76 mm alternate container study, it was found that the simple approach appears satisfactory for the purpose of comparing relative life cycle costs for the 76 mm containers. This comparison should be sufficient on which to base a selection decision for the type of container, and in evaluating quotes to obtain the lowest life cycle cost comparison figure for competing container candidates.

APPENDIX C

REFERENCED MATERIAL

1. WH-8025-WF Ser 1546-74 dtd 6 Nov 74, Subj: 76 mm Ammunition; forwarding proposals for alternate packaging designs
2. WH-8025-JS dtd 29 May 75, Subj: Trip to Picatinny Arsenal's Packaging R & D Lab on 22 May 1975 to discuss the possible use of spiral wound paper containers for packaging 76 mm shells
3. WH-8051-JEB dtd 21 Jul 75, Subj: Foil Fiber Tube Container; info on
4. NWHL Report 7616 dtd Mar 76, Subj: Test and Evaluation of Spiral Wound Paper Container for 76 mm Cartridges
5. WH-8051-WHT dtd 5 Jan 76, Subj: 76 mm Alternate Pack "Fiberglass Container"
6. NWHL Report 7631 dtd 7 May 76, Subj: Evaluation of Crush Resistance of Super RBOC Containers "Steel Drum"
7. WH-8052-VS dtd Aug 71, Report TE ORD 04-08-71, Subj: Test and Evaluation of Bulk Pack, Polystyrene 5"/54 Cartridges, Unit Load, Fleet Issue, Experimental
8. WH-8051-JEB dtd 23 Jul 76, Subj: Alternate Packaging Method "Polystyrene Container"
9. WH-8051-HT dtd 4 Nov 71, Subj: Test and Evaluation of 5"/54 Plastic Cartridge Tanks, Self Extinguishing "Polyethylene Container"
10. NWHL Report 7642 dtd 28 May 76, Subj: Cold Drop Tests of Rotationally Molded Plastic Containers

WH-8025-WF:2.
Ser. 1546-74
6 November 1974

From: Commanding Officer, Naval Weapons Station Earle
Colts Neck, New Jersey 07722

To: Commander, Naval Sea Systems Command (SEA-6516)
Department of the Navy, Washington, DC 20362

Subj: 76mm Ammunition; forwarding proposals for alternate packaging designs

Ref: (a) 76mm Packaging Meeting conducted at NAVSEASYSOOM in
October 1974

Encl: (1) Preliminary cost analysis of packaging alternatives for
76mm Ammunition dated 11 May 1973
(2) Proposed Task Outline for alternate packaging for 76mm
Gun Ammunition
(3) WR-54/263

1. During the early development stages of the 76mm program, this activity was tasked to submit a proposal in regard to packaging the subject ammunition. Since NWHL had been working with a "bulk" palletizing concept for 5" and 8" cartridges, it was felt appropriate to introduce the bulk packaging concept in development of the new 76mm Ammunition. Feedback from the project office indicated their initial receptiveness to this approach and they requested a cost analysis on a per round basis be developed, comparing the proposed bulk packaging concept with development of a new cartridge tank and with other types of containers (i.e. paper, aluminum, etc.). Enclosure (1) was prepared comparing five types of proposed packaging concepts and concluding that NWHL's proposed bulk pack (at that time) was economically favorable.

2. Subsequent to the submission of enclosure (1), liaison with the ships' types indicated the desire to maintain the cartridge tank concept and not go to a large bulk concept due to the size and configuration of some of the designated combatants (PF, PHM, etc.).

3. Subsequent to this decision, a large quantity of cartridge tanks (Mk 11 Mod 0) used for the 3"/70 became available. Since these tanks were available at no cost (surplus), NWHL was directed to develop the required dunnaging change to the Mk 11 Tanks so that it would accommodate the new 76mm cartridge. To date, ammunition for Tech-Eval and IOT&E operations have been packaged in the Mk 11 Mod 0 Tanks and have been palletized in accordance with the palletization procedures for the 3"/70 ammunition.

W1-8025-WF:aa
Ser. 1546-74
6 November 1974

Production quantities of the 76mm will use the same tank, however, they will be palletized in a modular configuration (see enclosure (3)) which would permit the auxiliary ship to transfer half-size pallet loads to the smaller receiving ships.

4. Recently, a review of the long-term requirement for the subject ammunition indicate that the supply of surplus Mk 11 Mod 0 Tanks will be exhausted in the 1976 time frame. Accordingly, NEMIL was again directed by NAVSTAASCOM Headquarters to submit a proposal on an alternate packaging design for 76mm ammunition to fill requirements beyond 1976. The concepts submitted were again requested to be similar to the cartridge tank packaging system. Accordingly, enclosure (2) is submitted and proposes an evaluation of 5 to 10 concepts to accommodate 76mm ammunition. The concepts speak to inexpensive cartridge tank designs fabricated from a variety of materials. The cost and development time to pursue and validate the concepts are also contained in enclosure (2). Upon Command approval and acceptance of the proposal(s), NEMIL will establish an evaluation and development program. Upon completion of this program, the optimum concept(s) will be rigorously pursued in the areas of value engineering and production simplicity.

L. R. CAPINGE
by direction

M E M O R A N D U M

WH-8021-JS:aa
29 May 1975

From: J. Sycle

To: Exploratory Development File

Subj: Trip to Picatinny Arsenal's Packaging R&D Lab on 22 May 1975
to discuss the possible use of spiral wound paper containers
for packaging 76mm Shells

Encl: (1) Army Dwg. No. 7548613 Container Ammo Fiber M264 for 76mm Ammo
Army Dwg. No. 8863694 Container Ammo Fiber M306A1 for 76mm Ammo
Army Dwg. No. 75448301 Container Ammo Fiber M53A4 for 90mm Ammo
Army Dwg. No. 8837832 Container Ammo Fiber M435 for 105mm Ammo
Army Dwg. No. 9277352 Packing and Marking for Box Pallet Type,
Wirebound for 105mm HCW Ammo w/fuse for USAF (use only)
(2) Various pictures of the wire bound 105mm Ammo bulk packaging
container

1. Discussions were held with the following:

Mr. Philip Korman
Howard Weiner
Chuck Banta
Norman Epell

2. Norman Epell and J. Sycle conducted 36" end drop tests on a 55 lb dummy loaded M435 Army fiber container which holds a 105mm shell. This testing not previously performed by the Army proved that it is necessary to cushion both ends of the container in order to remove the shell.

3. Enclosure (1) drawings on 76mm containers show moulded or stamped end spacers and metal end caps which can possibly be utilized for the Navy's 76mm container. Typical examples of wall thickness and tolerances are also given which may serve as a guide. MIL-C-00243C Mil. Spec. on container, ammunition, fiber, spiral wound has been updated as of 20 June 1973. This spec. contains the necessary data for qualification testing of fiber containers.

4. Picatinny has a open ended R&D contract for manufacturing paper ammunition tubes with Ricciardi Company of Alpha, New Jersey which can be funded to obtain test samples for our 76mm container. A sketch is in the process of being prepared for a meeting with Ricciardi people.

M E M O R A N D U M

WH-8051-JEB:cm
21 July 1975

From: 8051 (J. Sperling)
To: File

Subj: Foil Fiber Tube Container; info on

Ref: (a) 8021 Work Order 4525000-5091

1. Two fiber tube containers manufactured by ~~R. Record~~^{Alpha} Co, ~~Atlanta~~^{Atlanta}, N.J. have been submitted to T&E (8051) for air leakage tests as requested by reference (a). Both containers are fabricated by a spiral winding process, but are different in the following respects:

- (a) Container #1 has a flame resistant chip board paper covered core with a spiral wound aluminum foil interior skin and a polyethylene-on-aluminum exterior skin. The two metal ends are secured to the tube by a ~~double~~^{single} crimp.
- (b) Container #2 has a chip board paper core material which has been wax dipped. The exterior skin is a black colored polyethylene-on-aluminum material. The two metal ends are secured to the tube by a double crimp.

2. The two containers were subjected to FED STD 101B Method 5009 (e) leakage tests after their caps were sealed with 1" wide aluminum tape, and then with 2" wide aluminum tape. The tape used conforms to MIL SPEC L-T-80A and is .003 thick with .002 adhesive. The results are:

- (a) 1" tape used on seam/joint of cap and tube-container #1 leaked at the taped seam and container #2 leaked at a dent near the bottom of the tube.
- (b) 2" tape used on seam/joint of cap and tube-neither container leaked. (The dent near the bottom of the tube of container #2 had been sealed with 2" tape prior to this second test).

Copy to:
J. Sycle ✓
W. Franz
L. Caringi
M. Gray
F. Wildey

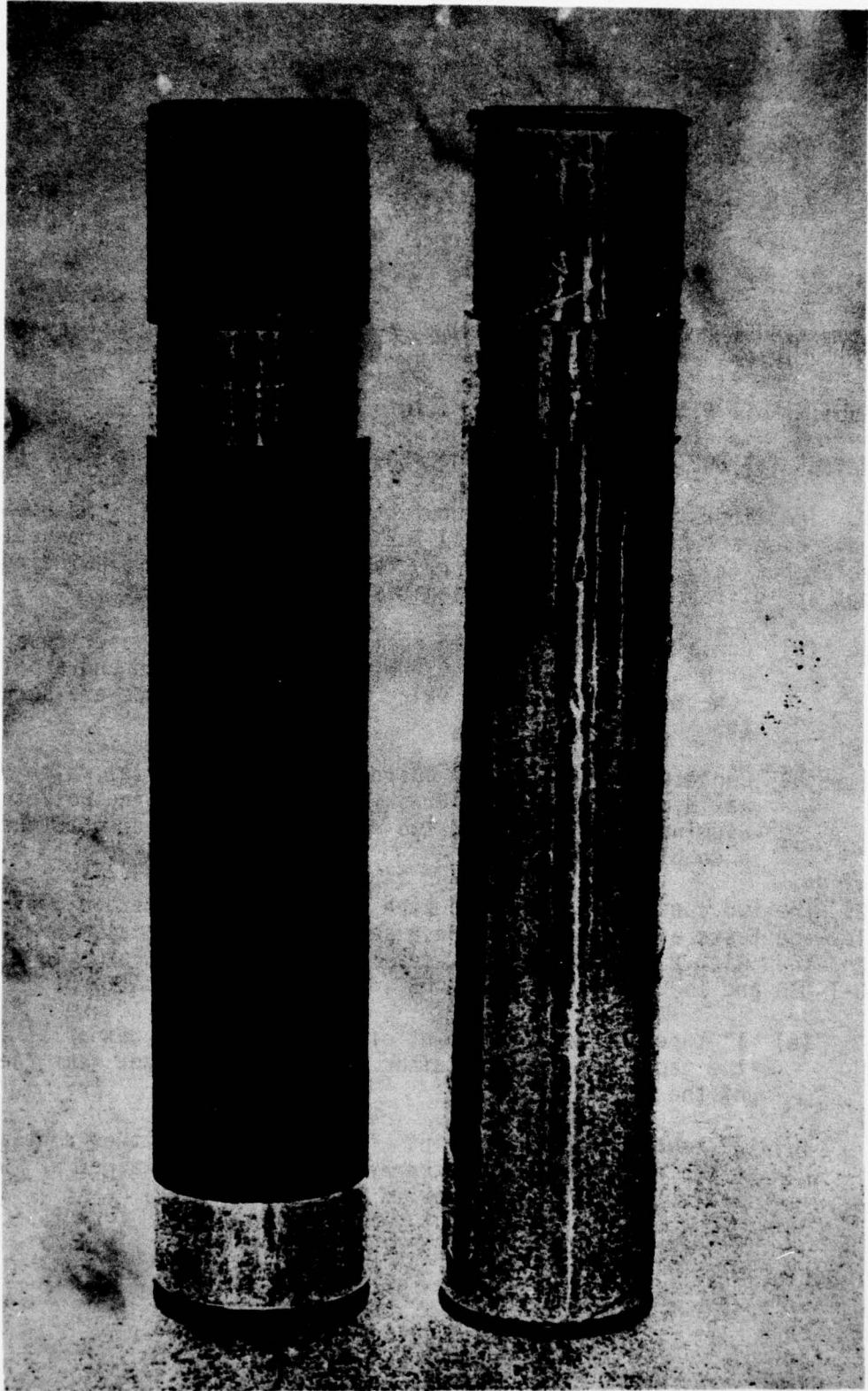

Container #1 is shown on the right
Container #2 is shown on the left
C-6

NAVAL WEAPONS STATION EARLE
NAVAL WEAPONS HANDLING LABORATORY

NWHL REPORT 7616
March 1976

Test and Evaluation
of
Spiral Wound Paper Container
for
76mm Cartridges

INTRODUCTION

A spiral wound paper tube type container manufactured by M. C. Riccriardi Company, Alpha, New Jersey, was submitted for testing. The purpose of this test was to determine the feasibility of using paper containers for cushioning protection of Naval ammunition for fleet issue under rough handling conditions. A previous test for moisture protection of a similar type container covered with a polyethylene film and aluminum foil spiral wound over a flame-resistant paper core had proven successful. See memorandum WH-8051-JRB of 21 July 1975 attached as Appendix A.

DESCRIPTION

The spiral wound paper container was manufactured to Army specification MIL-C-2439 Type 1 with two layers of aluminum foil embedded in the paper. Class 1 single

crimped metal caps were used on the paper tube ends. This container had been designed for an Army 76mm diameter shell, therefore it was only necessary to cut the container length in order to properly fit a Navy type 76mm 62 caliber cartridge.

Figure 1 shows the spiral wound paper container components and a 76mm cartridge prior to assembly. The parts shown from left to right are as follows:

- a. Spiral wound paper neck tube with metal end ring.
- b. Wooden projectile end plug.
- c. Two 2-lb. density polyethylene foam end spacers.
- d. Spiral wound paper body cover tube with single crimp metal end plate.
- e. 76mm dummy projectile.
- f. Spiral wound pipe end cover tube with single crimped metal end plate.

The container components and the 76mm cartridge are assembled by placing the neck tube (a) inside the body cover tube (d). The foam end spacers (c) are placed inside the tube and the cartridge (e) with its end plug (b) attached is inserted into the tube. The end cover tube (f) is then installed and sealed in place with 2" wide filament tape, Type PPP-T-97. The gross weight of the loaded container shown in Figure 2 is 35 pounds.

TEST PROCEDURES AND RESULTS

Repetitive Shock

The container was subjected to two hours of repetitive shock, one hour in the vertical plane with the container standing on end (Figure 3), and one hour in horizontal plane with the container lying on its side. All points on the container left the table by 1/16 of an inch during vibration at a frequency of 4Hz.

Results: There was no visible damage to the container after this test.

Corner Wise Drop

The container was subjected to 36" high drop tests as prescribed in MIL-T-18492 for cartridge tanks.

Results: The metal end plates of the container dented slightly. The single crimp ends held to the paper. The polyethylene foam spacers absorbed the shock and the shell was removed without damage.

CONCLUSION

The spiral wound paper container and its components appear to be satisfactory for use with the 76mm cartridge since no visible damage had occurred to the ordnance item.

Prepared by: J. P. Spurling
J. R. SPERLING
Engineering Technician

Approved by: J. E. Boyle
J. E. BOYLE
Weapons Handling
Branch

R. E. Seely
R. E. SEELY
Test & Evaluation
Division

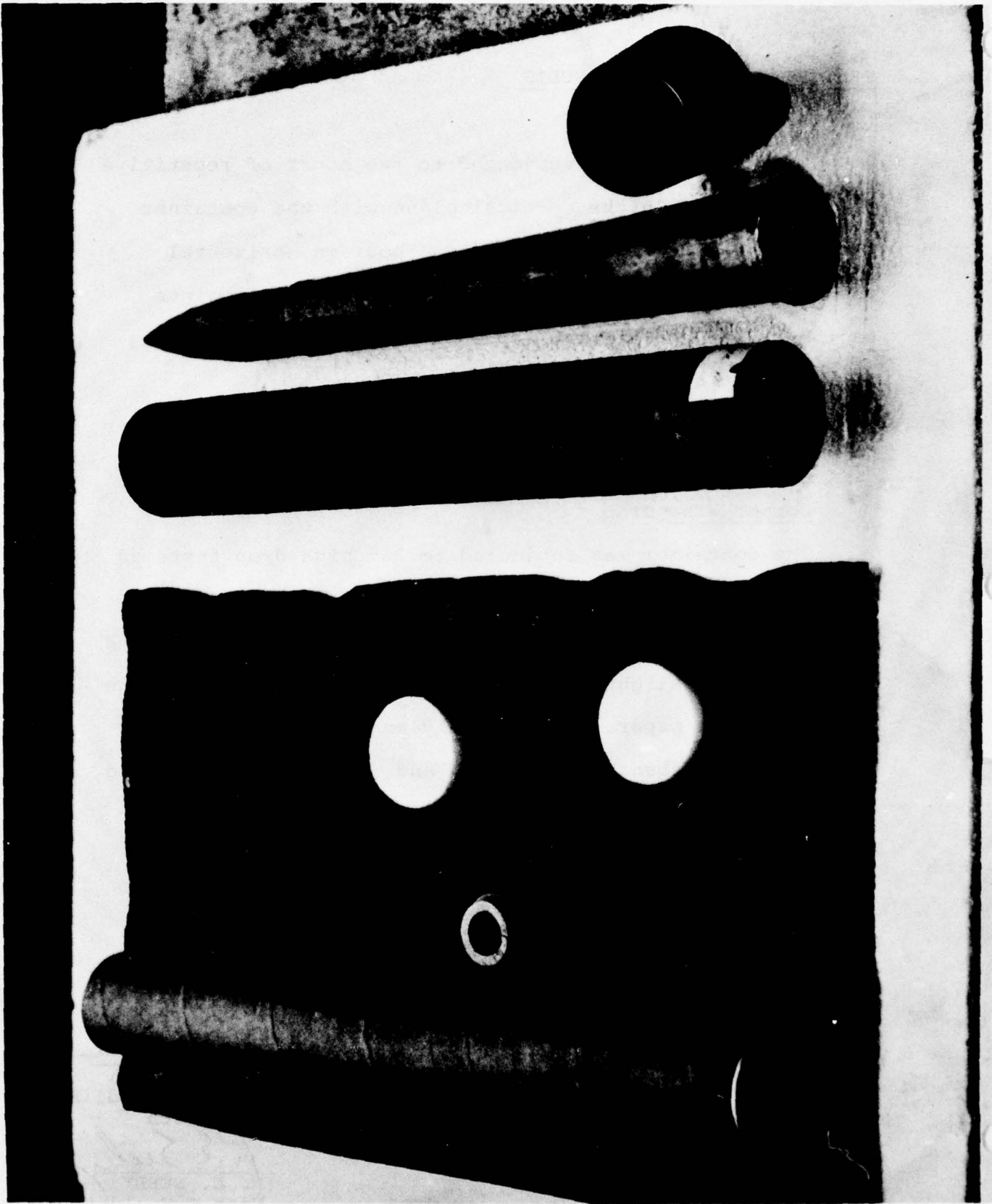

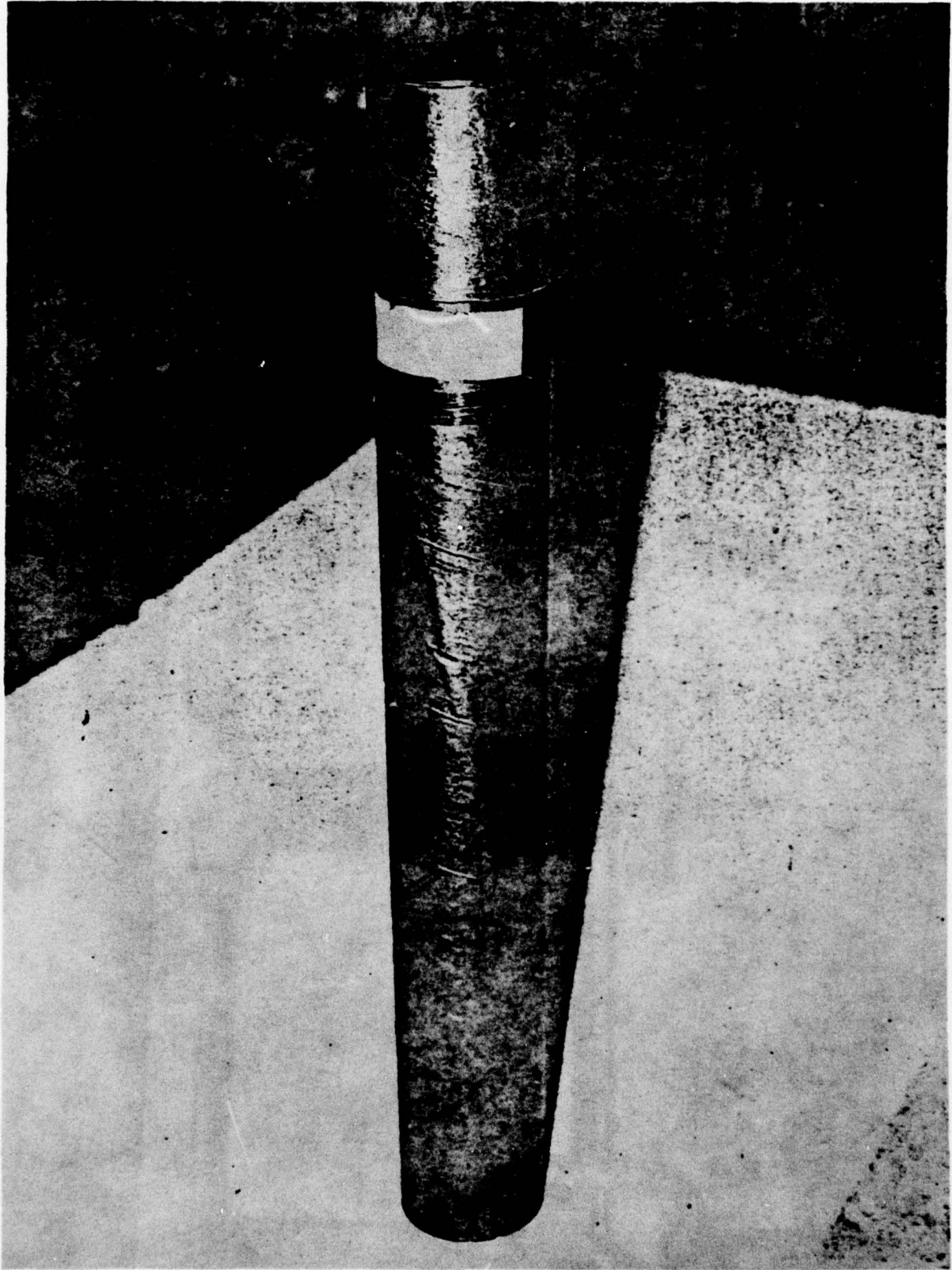
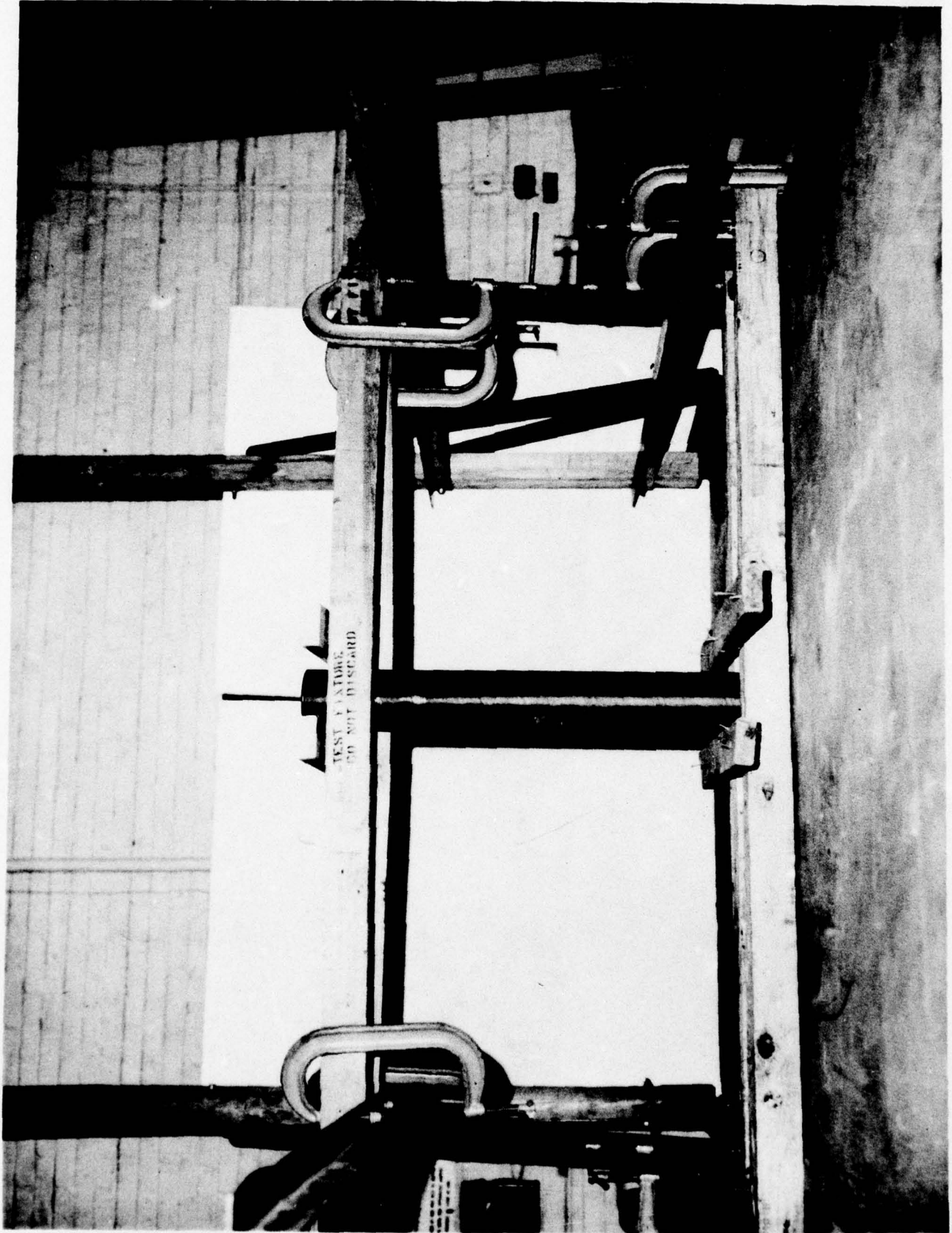

FIG. 2 ASSEMBLED CONTAINER
C-11



6-1

APPENDIX A

M E M O R A N D U M

WH-8051-JRS:mb
21 July 1975

From: 8051 (J.R. Sperling)
To: File

Subj: Foil Fiber Tube Container; info on

Ref: (a) 8021 Work Order 4525000-5091

1. Two fiber tube containers manufactured by Riccriardi, Alpha, New Jersey have been submitted to T&E (8051) for air leakage tests as requested by reference (a). Both containers are fabricated by a spiral winding process, but are different in the following respects:

- a. Container #1 has a flame resistant chip board paper covered core with a spiral wound aluminum foil interior skin and a polyethylene-on-aluminum exterior skin. The two metal ends are secured to the tube by a single crimp.
- b. Container #2 has a chip board paper core material which has been wax dipped. The exterior skin is a black colored polyethylene-on-aluminum material. The two metal ends are secured to the tube by a double crimp.

2. The two containers were subjected to FED-STD-101B Method 5009(e) leakage tests after their caps were sealed with 1" wide aluminum tape, and then with 2" wide aluminum tape. The tape used conforms to MIL-SPEC-L-T-80A and is .003 thick with .002 adhesive. The results are:

- a. 1" tape used on seam/joint of cap and tube-container #1 leaked at the taped seam and container #2 leaked at a dent near the bottom of the tube.
- b. 2" tape used on seam/joint of cap and tube-neither container leaked. (The dent near the bottom of the tube of the container #2 had been sealed with 2" tape prior to this second test).

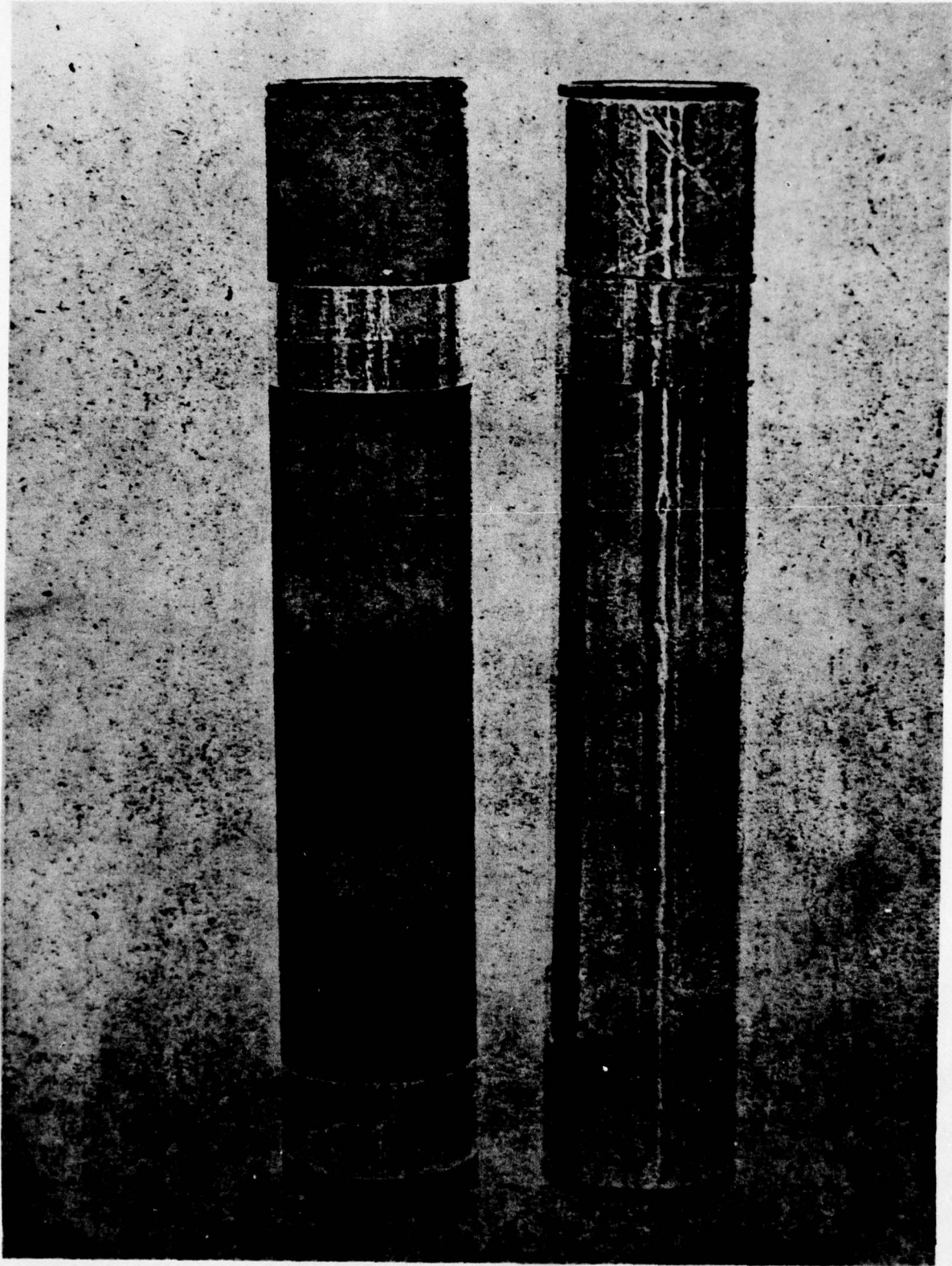

Container #1 is shown on the right
Container #2 is shown on the left

SPIRAL WOUND CONTAINER

C-14

M E M O R A N D U M

WH-8051-WHT:mb
5 January 1976

From: Code 8051 (W.H. Trowbridge)
To: File

Subj: 76mm Alternate Pack

Ref: (a) Request for preliminary testing of alternate pack

1. One fiberglass - resin impregnated tube for use as a 76mm cartridge container was subjected to preliminary testing at low temperature in accordance with reference (a). The tubular container had been fabricated on a 5-inch diameter mandrel with approximately 1-3/4" wraps of basket weave fiberglass cloth impregnated with a polyester resin. The manufacturer was the Reinforced Plastics Inc., Division of SGL Industries Inc. The physical characteristics stated by the manufacturer for temperature range of -60°F to +350°F are as follows:

Impact strength edgewise ----- 17 ft. lbs/inch
Impact strength flatwise ----- 33 ft. lbs/inch
Tensile strength ultimate ----- 40,000 psi.
Good weathering under conditions of exposure to salt and fresh water.

Each end of the tubular container was closed by means of several foam polyethylene discs secured with 1" fiberglass tape. A 76mm cartridge was stabilized inside the 5" inside diameter tube by a plastic retainer end cap and a polyethylene nose cap set into a standard aluminum retainer for the 3"/70 cartridge tank. This alternate pack measured 5 1/8" diameter outside by 49" long and weighed 33 pounds gross.

2. The packed container was subjected to the Free Fall Drop Test, paragraph 5.2.3 of MIL-STD-648, conditioned at -20°F, from a drop height of 30 inches. This test specified a series of four drops on diagonally opposite end corner points, three flat side drops and one end drop (bottom). The results of this test revealed that this fiberglass container was capable of withstanding the shocks without failure and afforded good protection to the 76mm projectile. The data sheet 1 of 1 is attached.

3. It is recommended that further effort be allocated to promote the use of this material for use in a complete cartridge container.

Copy to:
W. Franz
J. Sycle
F. Wildey (P. Krupa)
L. Caringi
M. Gray/R. Seely

SUBJECT:

76mm CARTRIDGE IN ALTERNATE PACK

DATE: 30 December 1975

PRELIMINARY TESTING OF FIBERGLASS AND RESIN CONTAINER

TESTED BY: W.H. Trowbridge

MIL-STD-648 Para. 5.2.2

REPETITIVE SHOCK TEST

This test was not performed

Face 3 Bottom Down Frequency _____ HZ. Duration _____ Hr.

Face 2 Side Down Frequency _____ HZ. Duration _____ Hr.

Face 5 End Down Frequency _____ HZ. Duration _____ Hr.

Results:

MIL-STD-648 Para. 5.2.3

FREE DROP TEST

Drop height 50 inches
The packed container was conditioned at -20°F for 12 hours.

RESULTS

Satisfactory

Satisfactory

Satisfactory

Satisfactory

Satisfactory

Satisfactory

Satisfactory

Satisfactory

CONTAINER WEIGHT:

Tare Weight 3.0 lbs.

Net Weight 27.0 lbs.

Gross Weight 33.0 lbs.

CONTAINER SIZE:

Length 5-1/8 inches

Width 5-1/8 inches

Height 49 inches

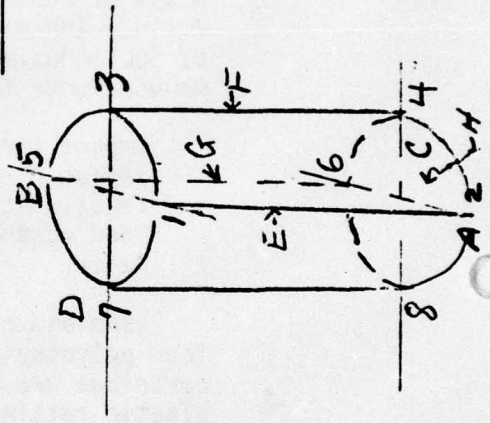

NWHL Report 7631
7 May 1976

NAVAL WEAPONS STATION EARLE
NAVAL WEAPONS HANDLING LABORATORY

EVALUATION
OF
CRUSH RESISTANCE
OF
SUPER RBOC CONTAINERS

INTRODUCTION

A cylindrical container manufactured by Mirax Chemical Company of St. Louis, Missouri, has been submitted for evaluation to determine its crush resistance under simulated conditions of like containers palletized and tiered for storage. The container is to be used for shipping and storing the Super RBOC Type II ordnance item.

DESCRIPTION

The container, except as noted on NOL White Oak Drawing No. 3192614, was manufactured in accordance with MS 24347 Rev. E, Body Type I, and MIL-D-6055. Figure (1) shows the container, components, and a Super RBOC prior to assembly. The items shown from left to right are as follows:

- a. Plywood and polyethylene bottom end spacers
- b. Super RBOC Weapon
- c. Super RBOC launcher barrel, cover and "O"ring

d. Top polyethylene spacer

e. Super RBOC metal container, cover, and clamping ring. (NOTE: The container wall thickness is .024".)

The container, components and the Super RBOC are assembled by first placing the plywood and polyethylene bottom spacers in container. The Super RBOC is then placed into the container, shaft end down. The launcher barrel then slides over the Super RBOC weapon into the container. The polyethylene top end spacer is placed in the container and the cover and clamping ring tightened in place. The gross weight of the loaded container is 54 pounds.

TEST PROCEDURE AND RESULTS

A complete palletized unit load of inert Super RBOC containers was not available for this test. Palletized Super RBOC containers are to be stacked vertically in a straight column, four containers to a column, six columns wide on a Mk 3 Pallet, or 24 containers per unit load. Two containers were used to simulate a stacking overload test. The bottom container (see Figure 2) was loaded with the inert Super RBOC weapon and the top container was dummy loaded to 54 pounds. A 42 pound wood platform was placed directly on top of the two stacked containers (see Figure 2). Appropriate loading was then applied to the container column test fixture by a Riehle compression test machine to simulate the loading on the bottom container in tiered unit loads.

<u>Simulated Unit Loads Tiered</u>	<u>Load Applied to Test Container</u>	<u>Results Noted</u>
1	162 lbs.	
2	372 lbs.	1/32" deep dent
3	584 lbs.	1/16" deep dent; 1/2" long
4	800 lbs.	3/16" deep dent; 13/16" long
5	1125 lbs.	5/16" deep dent; 1-11/16" long

RESULTS: The 5/16" deep, 1-11/16" long dent, shown in Figure 3, did not prevent the undamaged contents from being removed from the container.

CONCLUSIONS

The metal container suffered dents during this evaluation, but these simulated static test conditions did not cause any damage to the packaged Super RBOC weapon. No dynamic rough handling tests were performed at this stage of the evaluation. The thin walled container could conceivably suffer extensive damage during such testing. Therefore, additional testing which would involve rough handling tests are recommended before a judgement can be made concerning the adequacy of this stacking method.

Prepared by: J.R. Spurling
 J.R. SPURLING
 Engineering Technician

Approved by: J.E. Boyle
 J.E. BOYLE
 Mechanical Test Branch

R.E. Seely
 R.E. SEELY
 Test & Evaluation Division



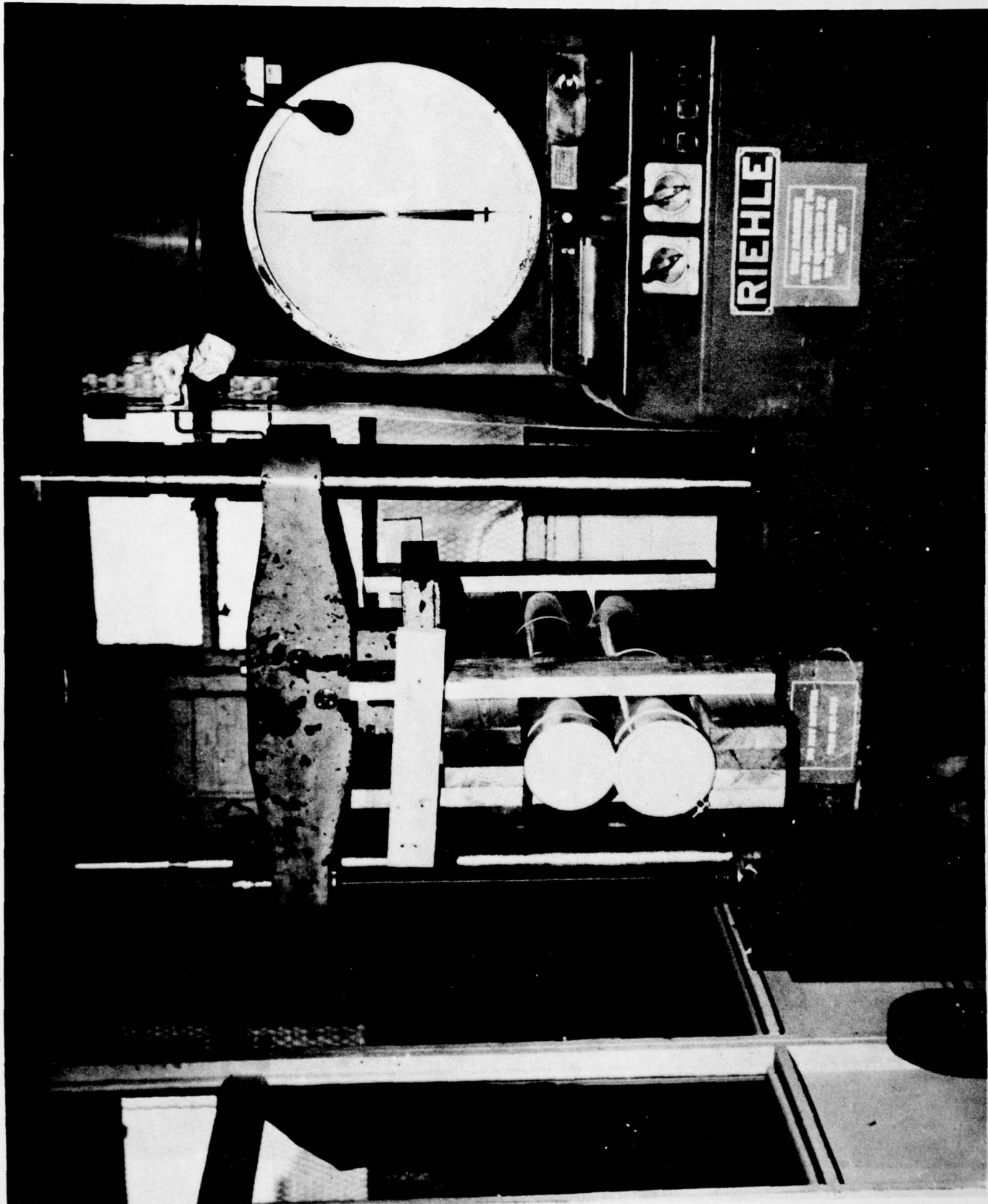

REUSABLE DRUM
DO NOT DESTROY

MEMORANDUM

WH-8052-VS:ck
August 1971

From: Code 8052 (T&E)

To: Code 8021 (ED)

Subj: Test and Evaluation of Bulk Pack, Polystyrene, 5"/54
Cartridges, Unit Load, Fleet Issue, Experimental

1. In accordance with request from ED (J. Sycle), the subject unit load was tested and evaluated. Report TE ORD 04-08-71 is attached.

2. The unit load has satisfactorily met the tests although it was noted that there were no provisions to protect the items from moisture condensation and no extreme temperature tests were requested or performed.

Copy to:

WH-8052 (S. Seely, M. Gray)
WH-8021 (L. Carney)
WH-8052 (J. Sycle)
WH-8052 (The Office)

Report TE ORD 04-08-71
August 1971

TEST AND EVALUATION
OF
BULK PACK, POLYSTYRENE, 5"/54 CARTRIDGES
FLEET ISSUE UNIT LOAD, EXPERIMENTAL

V. SAUL

W. H. TROWBRIDGE

NAVAL AMMUNITION DEPOT EARLE
NAVAL WEAPONS HANDLING LABORATORY
EGG HARBOR, NEW JERSEY 07702

FORM NO. 10 (REV. 10-69)

NAVAL AMMUNITION DEPOT EARLE
NAVAL WEAPONS HANDLING LABORATORY

TEST AND EVALUATION
OF
BULK PACK, POLYSTYRENE, 5"/54 CARTRIDGES
FLEET ISSUE UNIT LOAD, EXPERIMENTAL

Abstract

An experimental palletized unit load of 5"/54 cartridges bulk packed in polystyrene was tested to determine whether it would be feasible as a Fleet Issue Unit Load. The tests consisted of low-order repetitive shock, rotational drop, wall-impact and proof of stacking strength, conducted in an ambient temperature of 80° F.

The unit load successfully completed the tests; however, it was noted that some form of moisture protection was needed for the packaged cartridges. No extreme temperature tests were conducted during this phase of testing.

Reviewed by J. E. Boyle 2/22/71
R. S. Seely 2/22/71

INTRODUCTION

As a cost reduction effort, an experimental palletized unit load consisting of twenty-four 5"/54 cartridges bulk packaged in polystyrene trays was designed and tested. Testing was conducted on the unit load in accordance with applicable paragraphs of Naval Ordnance Requirements OR-11 to determine its suitability for handling, storage and Fleet Issue. This method of packaging proposed to substitute 10 molded polystyrene trays weighing 60.75 lbs. and 5 pieces of 1/4" plywood weighing 41 lbs. for twenty-four aluminum Tanks, Cartridge, Mk 14, and an Adapter, Pallet, LD 296489.

DESCRIPTION

The unit load consisted of twenty-four 5"/54 cartridges positioned horizontally in polystyrene trays. The trays consisted of two bottom, six intermediate and two top sections assembled on a 40" x 48" Pallet, Mk 3 Mod 0. The unit load was comprised of four tiers, two trays per tier, each tray containing three cartridges. One side of each tray was stenciled with directional arrows and lettering to facilitate palletization. The trays were fabricated by Sinclair-Koppers Co., and consisted of Dylite Expandable polystyrene bead board, (density: 2 lbs. per cu/ft), hot-wired to shape. One-quarter inch thick plywood sections were used to protect the sides and top. Four 3/4" x .035" steel straps were used to secure the load. The unit load gross weight was 870 lbs. The overall dimensions were 40" L x 48" W x 48-1/2" H. (See Figures 1, 2 and 3.)

TEST PROCEDURE AND RESULTS

All tests conducted in accordance with Naval Ordnance Requirements OR-11 in an ambient temperature of 80° F in the sequence described below:

1. Low Order Repetitive Shock. The unit load was subjected to repetitive shock for two hours at one-inch vertical double amplitude with all four points of the unit load leaving the table a distance of not less than 1/16" at some instant during each cycle.

RESULTS - The frequency at this point was 3.8 Hz. Examination after this test revealed no damage to the unit load.

2. Rotational Drop Test. The unit load was supported at one end by a six-inch block at one corner and a twelve-inch block at the adjacent corner. The corner diagonally opposite the twelve-inch block was raised to a height of eighteen inches and subjected to free-fall and impact on an unyielding concrete surface. All four corners were impacted in this manner.

RESULTS - During this test there was minor racking but the load remained intact and transferable. There was no visible damage.

3. Wall-Impact Test. The unit load was impacted on all four sides by means of the pendulum method against an 10" high steel block at 20 ft/sec. The surface of the unit load was examined

to strike the abutment 9" down from the top. The load was lifted by a monorail hoist utilizing a Sling, Universal Pallet, Mk 87, with a 4000-pound capacity strongback.

RESULTS - At the completion of this test there was no visible indication of damage and the load was intact and transferable. However, at the completion of all the prescribed tests, disassembly and examination of the unit load revealed some cracking of the trays had occurred at the point of impact. (See Figure 4.)

4. Test for Proof of Stacking. In an effort to simulate the load distribution induced by top loading with identical loads and a stacking height of 15 feet, a top load of 6000 pounds was positioned on a second Pallet, Mk 3 Mod 0, placed on top of the unit load. This test method simulated the loading condition on the bottom container caused by loads tiered four high and multiplied by an acceleration test factor of 2 specified by the applicable test method for non-metallic containers. This load was held for a one-hour period.

RESULTS - At the completion of this test there was no indication of damage to the unit load. (See Figure 5.)

5. Visual Inspection. In a post-test examination, the load was disassembled and it was noted that there was considerable moisture accumulation in each cartridge recess. There was no other damage to the cartridges.

CONCLUSIONS

Although some damage was incurred during the wall-impact test, the unit load was intact and transferable at the completion of all the required tests. The experimental unit load of twenty-four 5"/54 cartridges palletized in expanded polystyrene trays is considered to have completed the tests satisfactorily. However, it was noted that some form of moisture protection was needed for the packaged cartridges.

This unit load cannot be considered suitable for handling, storage or Fleet Issue until extreme temperature test requirements of OR-11 are met and the plastic material meets the self-extinguishing flammability tests of Federal Test Standard 406 Method 2021.

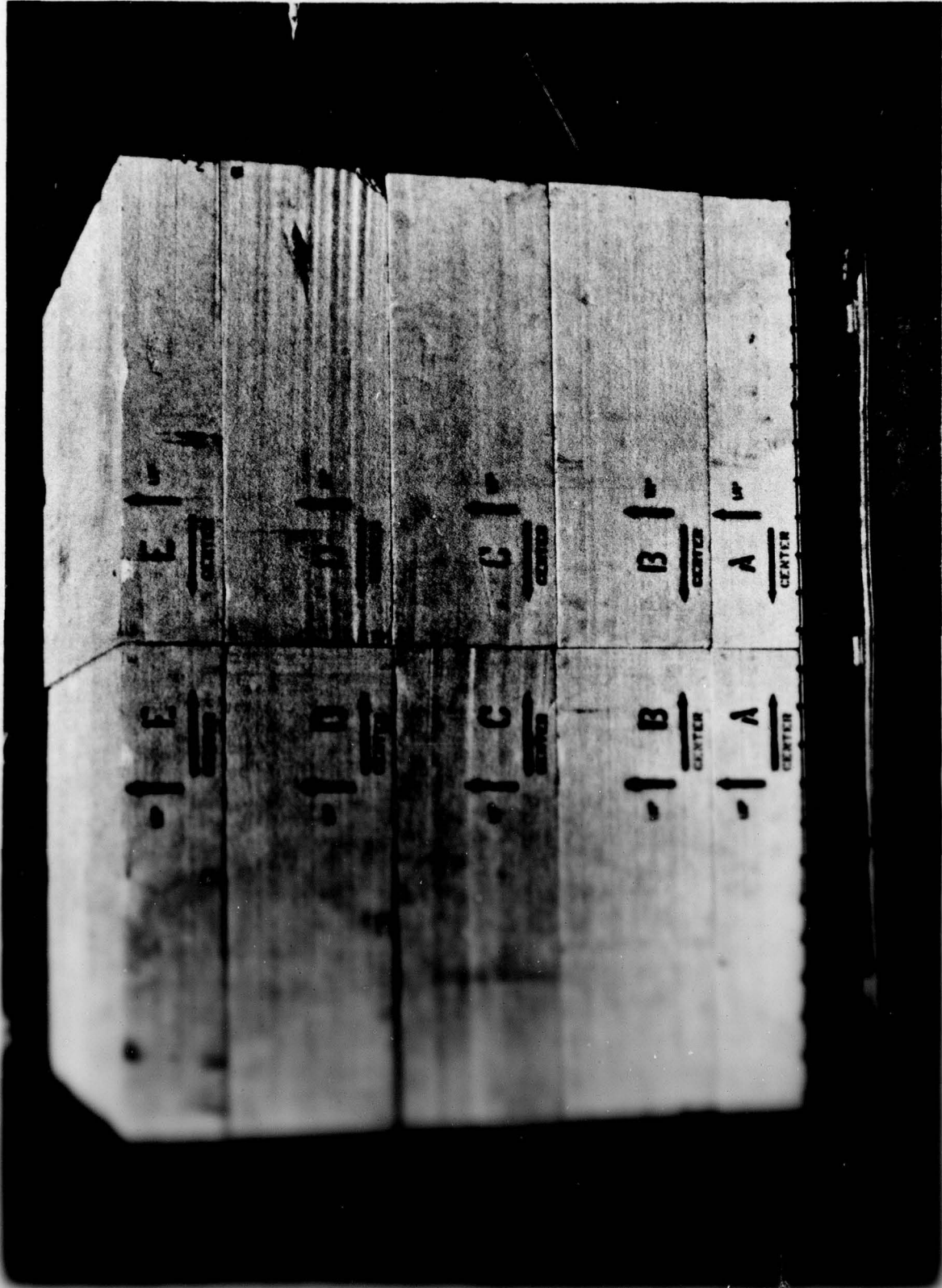

Fig. 1 Tray Sections with Cartridges Enclosed, Assembled on Pallet.
C-31

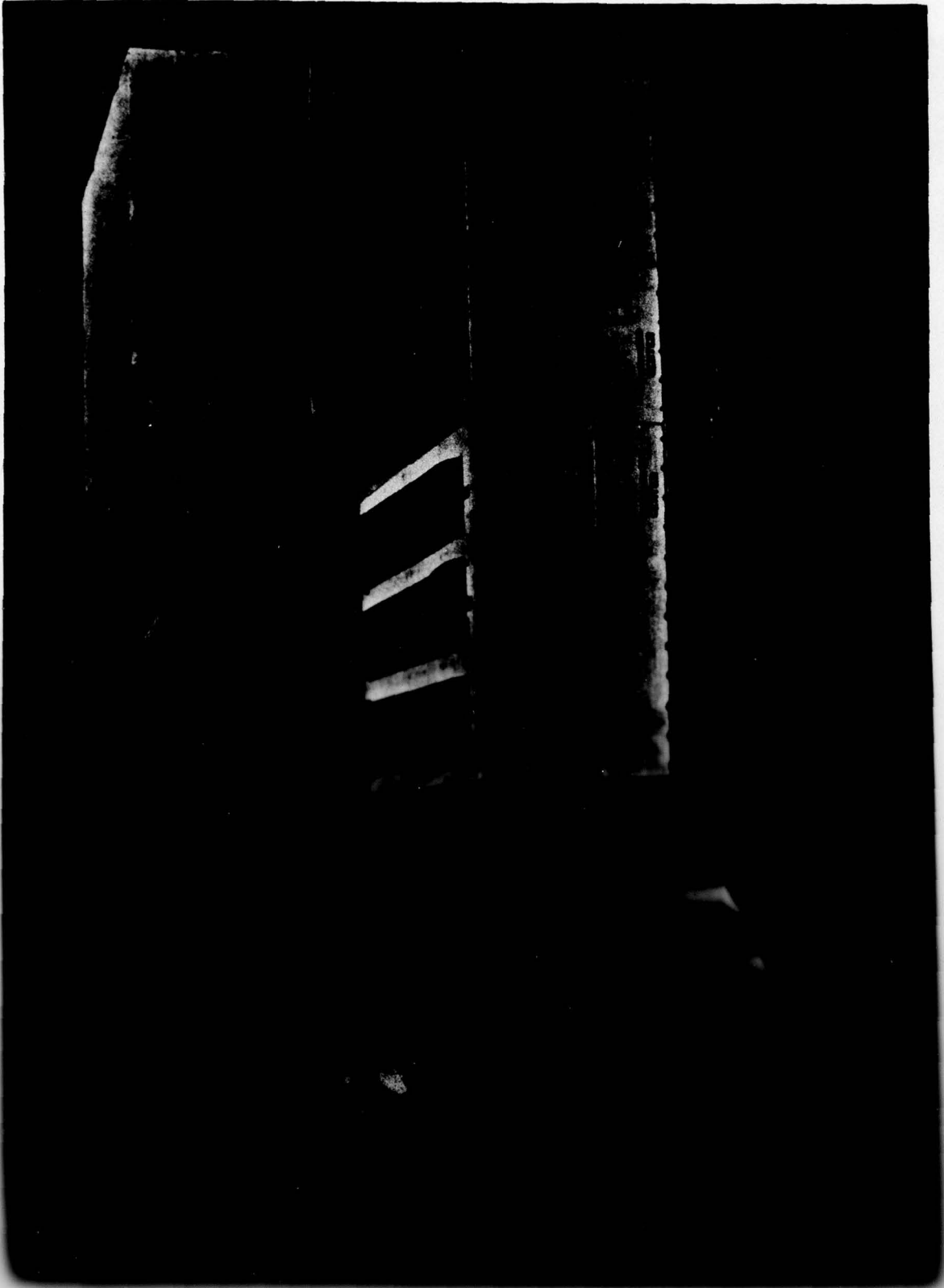

Fig. 2. Tray Sections Removed to Show Cartridge Assembly.
C-32

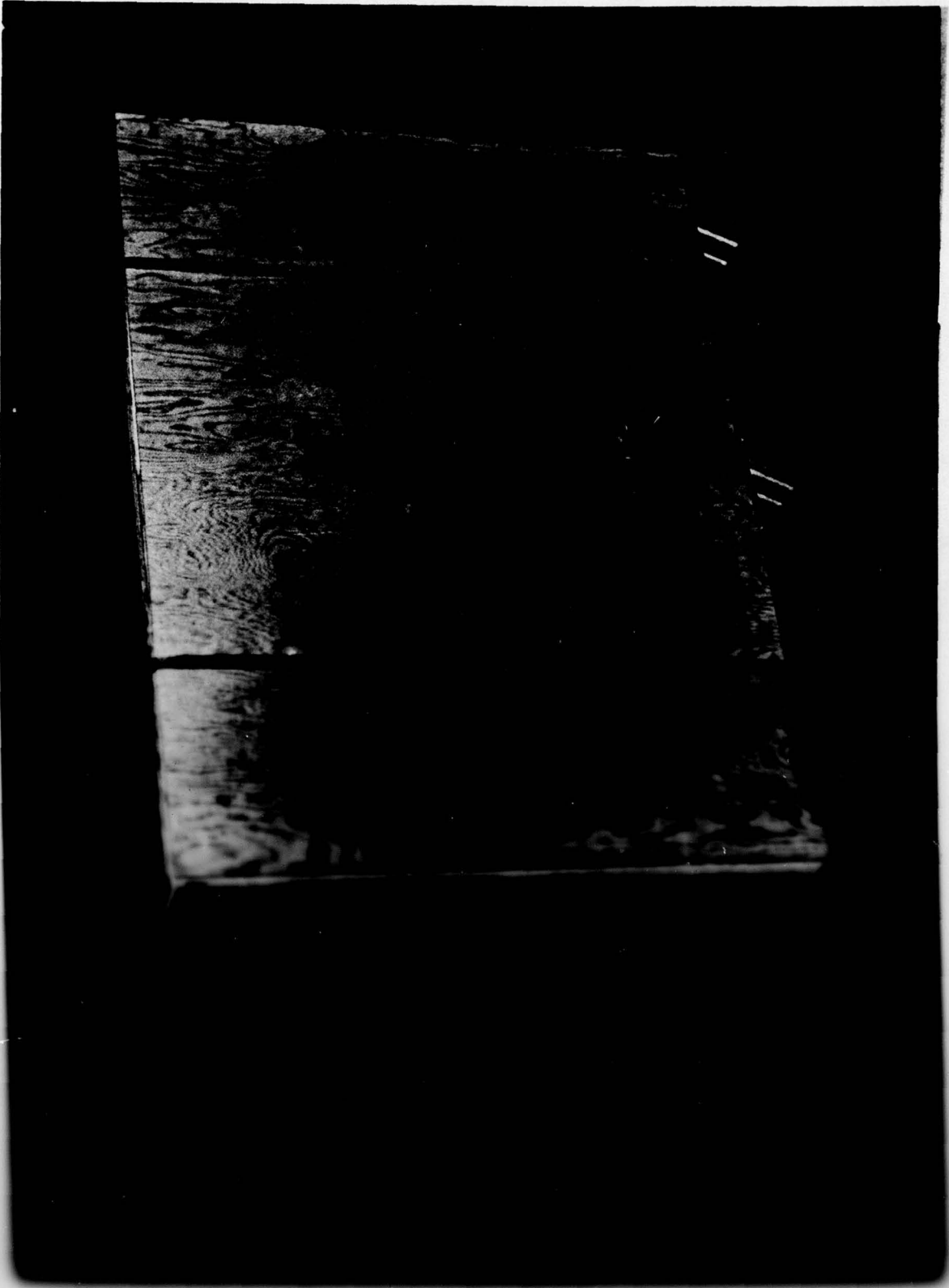
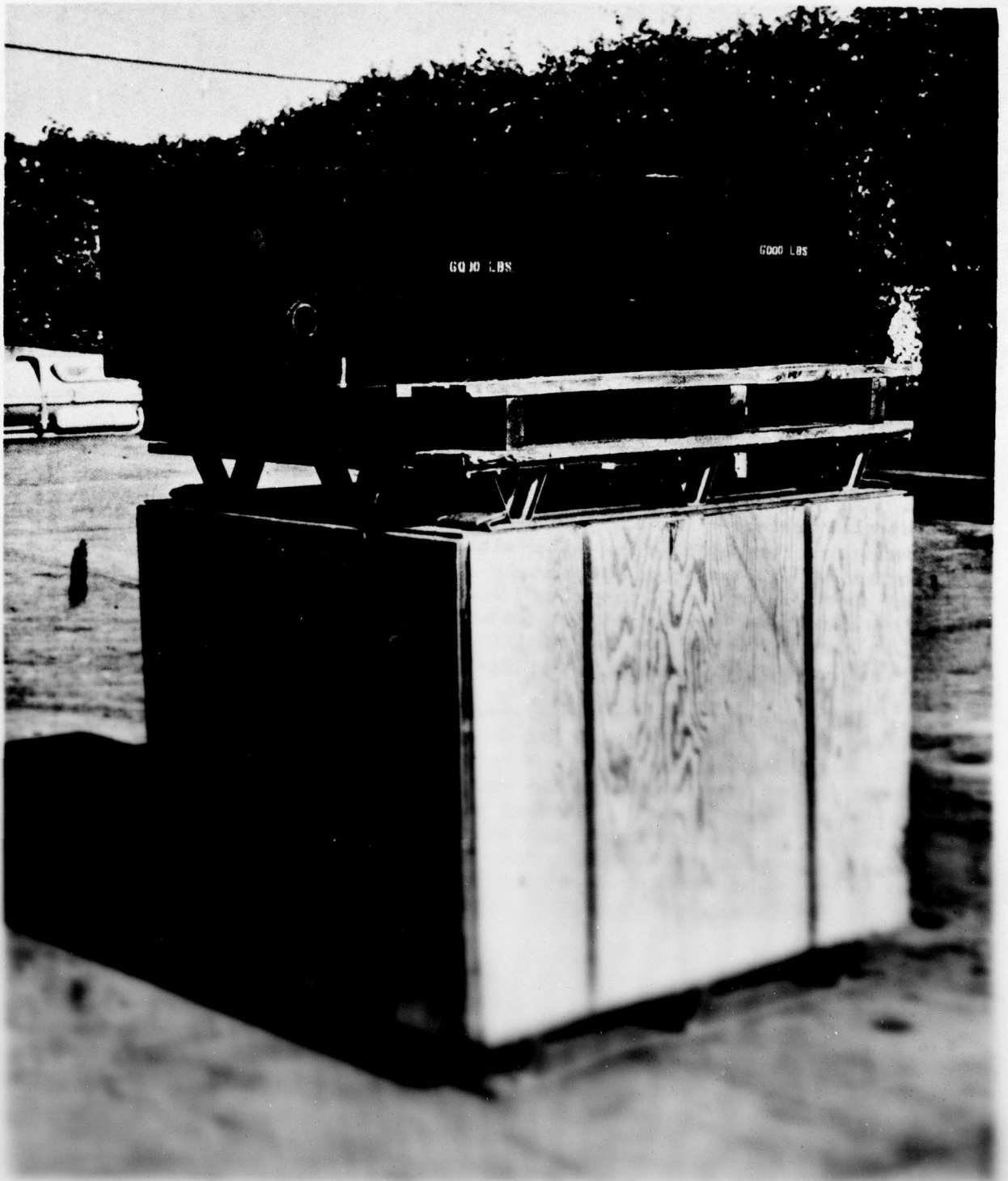

Fig 3. Unit Load, Bulk Pack, Polystyrene, 5"/54 Cartridges.
C-33



Fig. 6. Polystyrene Trays Crack at Point of Wall Impact.

C-34



M E M O R A N D U M

WH-8051-JEB:dd
23 July 1976

From: Code 8051
To: 76mm Cartridge File

Subj: Alternate Packaging Method

Ref: (a) 8021 Work Request 4596000-0965 dated 30 June 1976.

Encl: (1) Insuldyne Corp. Specification Bulletin 8B/Ip.

1. As requested by reference (a) , a molded polystyrene pipe insulation material described in enclosure (1) has been subjected to a preliminary evaluation for possible use as an alternate method of packaging a 76mm cartridge. The attached photographs show the packaging sequence. The end spacers shown in Figures 1 and 2 are also polystyrene material, the tape used to secure the package (Figure 3) is 1" wide nylon reinforced glass tape. The package has a 7 1/2" diameter and is 45 1/2" long, its loaded weight is 30 pounds (cartridge = 28 pounds; polystyrene = 2 pounds).

2. The packaged cartridge was subjected to eight free fall drops from a height of 21" as specified in MIL-STD-648 and FED-STD-101 Method 5007. Four corners/edges, two sides and both ends were impacted during these weight drops. The outside of the container suffered minor crushing at the corner impact points. The drop on one end caused the nose of the nose round to indent the polystyrene end spacer a depth of 1 1/8 inches. The rim/flange at the cartridge base scuffed the inner wall of the package as the round shifted forward on this same drop. By replacing the impacted end spacer, the packaging material could be reused.

3. The molded polystyrene material withstood the eight drop tests with very little damage occurring. It is extremely light and easy to handle, and the cost per package is approximately \$1.50 (per 1.00 lb. total). The number of times the packaging material could be reused is unknown and would depend largely on the amount and degree of rough handling each individual package receives.

13.04

AD-A054 063

NAVAL WEAPONS HANDLING CENTER COLTS NECK N J
PACKAGING FOR 76 MM OTTO MELARA AMMUNITION. PHASE I, (U)
SEP 77 D D MACLEOD
NWHC-7786

F/G 19/1

UNCLASSIFIED

NL

2 OF 2
ADA
054063

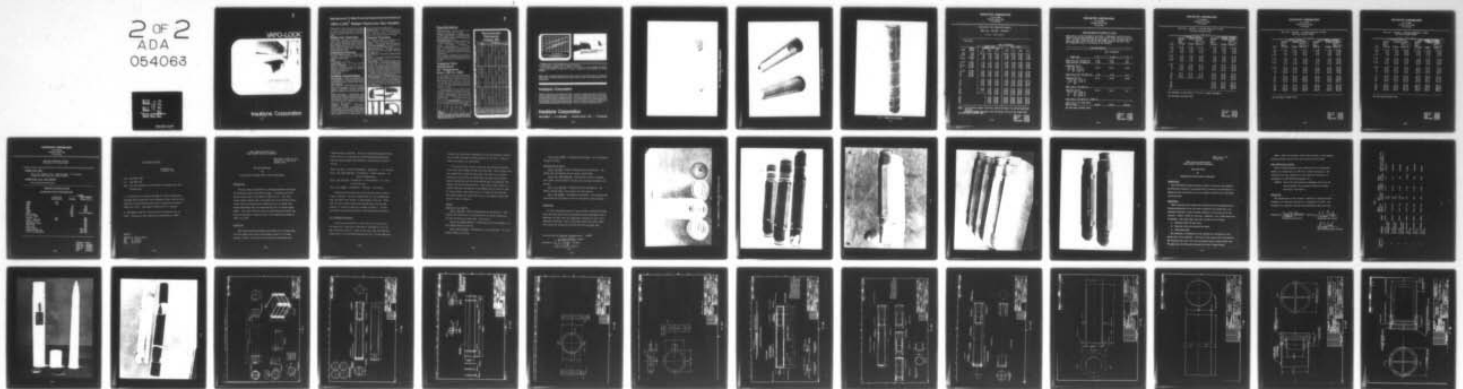

END
DATE
FILMED
6-78
DDC

VAPO-LOCK®

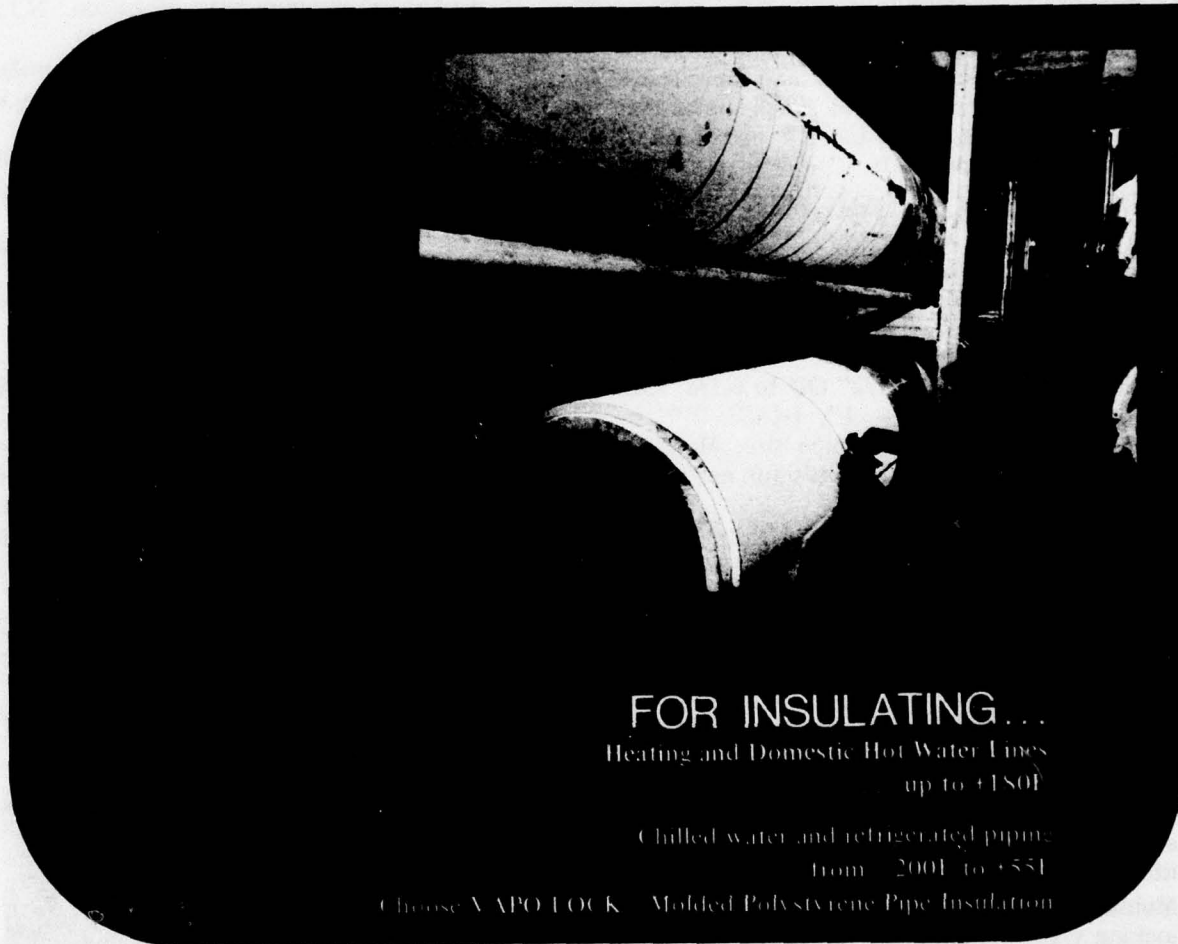

FOR INSULATING...
Heating and Domestic Hot Water Lines
up to +180F

Chilled water and refrigerated piping
from -200F to +55F

Choose VAPO-LOCK - Molded Polystyrene Pipe Insulation

Insuldyne Corporation

Manufactured To Meet Exacting Engineering Specifications!

VAPO-LOCK[®] Molded Polystyrene Pipe Insulation

VAPO-LOCK[®] is made for the particular engineer who requires the best insulating characteristics for his job. It is particularly suited for insulating piping in temperature ranges from -200F up to +180F.

Molded Not Fabricated

VAPO-LOCK[®] is molded from expanded polystyrene beads. High-density molding produces pipe insulation and fittings highly resistant to physical damage, thermal shock and vapor transmission. More than twice as much material is used in producing VAPO-LOCK[®] compared to similar insulating products.

Engineering Features

Pipe And Fittings Availability - VAPO-LOCK[®] is molded in half sections for all sizes of pipe, tubing and related fittings:

SIZES

Iron Pipe (IPS) - 1/4" to 24"

Copper Tubing (CT) - 1/2" OD to 6-1/8" OD

Insulation Thicknesses - 1", 1-1/2", 2"* , in single layer depending on pipe size. Made to simplified dimensional standards for nesting in multiple layer applications.

Section Length - 4'

*Iron pipe size only.

Insulating Characteristics

Water Resistance - There is no capillary action in VAPO-LOCK[®]. It is water and vapor resistant. Under certain less severe conditions, vapor barriers may be eliminated.

Low "K" Factor - VAPO-LOCK[®] has a low "K" factor when compared with other insulating materials. VAPO-LOCK[®] maintains insulating efficiency throughout exceptionally long service life.

Molded Joint System - VAPO-LOCK[®] interlocking system eliminates straight-through joints minimizing heat transfer at these points. Molded tongue-and-groove longitudinal joints and shiplap butt joints provide a precision fit between sections of pipe insulation.

Installation Advantages - VAPO-LOCK[®] sectional pipe insulation is manufactured in 4-foot lengths. The 4-foot, half cylinders reduce the number of joints by one-third. VAPO-LOCK[®] is easy to handle, goes on quickly because it is light in weight and can be easily fabricated on

the job with an ordinary knife or saw.

Maximum Safety - VAPO-LOCK[®] presents no health hazards. It is made of non-dusting, non-toxic, beads which contain no sharp particles likely to penetrate skin, eyes, nose or lungs.

Physical Properties

U.S. Testing Company, Inc., Hoboken, N.J., (Reports 58258-1, 58258-2 and 58258-3)

Density - 2.2 pounds per cubic foot (nominal).

Water Vapor Transmission - 0.6 - 0.8 perm inch per A.S.T.M. C355-59T (S-K 43-480)

Thermal Conductivity - "K" factor of 0.21 at 40F and 0.23 at 75F per BASF publication #7.14/BA, 1973.

Heat Resistance - No distortion within specified limits.

Strength - Compressive strength at 5% deformation . . . 25 to 30 PSI.

Combustibility - VAPO-LOCK[®] molded polystyrene beads are self-extinguishing. Beads melt at high heat, will not ignite spontaneously.

Extensive test programs have been conducted to determine if thermal decomposition products of expanded polystyrene present a toxic hazard. Test results revealed that toxicity on inhalation is decidedly less than that of fumes from wood and other conventional building materials.

Moisture Resistance - The high-density molding of VAPO-LOCK[®] provides an unusually low water vapor transmission rate. Molded blocks of the base material have been utilized as flotation and exposed to water for years without major loss of properties.

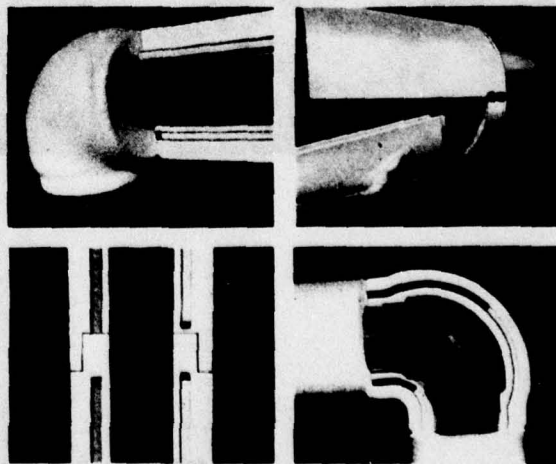

Specifications

Temperature Range – Recommended for continuous use between +180F and -200F.

Coefficient of Expansion – 0.00003 in./in./degree F. VAPO-LOCK® is exceptionally stable, assuring negligible expansion or contraction due to temperature variations.

Other Characteristics – Odorless and non-toxic... will not absorb odors... non-corrosive... pH neutral... non-dusting... non-abrasive... resistant to mold, rot and vermin... has no food value... an ideal insulation material for general application... its clean white appearance makes it particularly applicable for food processing and storage areas.

Mastics, coatings or adhesives that contain solvents may attack VAPO-LOCK® and should not be used, until tested to the satisfaction of the specifier.

Suggested Base Specifications For Temperatures From +35F to +180F

All cold piping as well as heating and domestic hot water piping not exceeding +180F shall be insulated with a molded, expanded, polystyrene pipe covering having a density of not less than 2 lbs. per cubic foot and permanent "K" factor of .23 at 75F mean. Water vapor transmission should be no more than 0.8 perm inch per A.S.T.M. C355-59T.

Covering material shall have molded tongue and groove longitudinal and shiplap butt joints. It shall be applied in accordance with manufacturer's recommendations. Joint sealer shall be Daxcel #161, Childer's Chil-joint CP-70, or approved equal. *(Continued on next page)*

VAPO-LOCK ELL SIZES					
	# 1/2	# 1	# 2	# 3	# 4
IPS	1/2" 3/4" 1"	1/2" 3/4" 1"	1 1/4" 1 1/2" 2"	2 1/2" 3"	4" IPS Long-Radius Weird Ells Only
CT	3/8" 7/8"	7/8" 1 3/8"	1 1/4" 2 1/8"	2 1/4" 3 1/8"	—
Wall Thicknesses Available	3/4"	1" 1 1/2" 2"	1" 1 1/2" 2"	1" 1 1/2"	1" 1 1/2"

Because of the unique design of Vapo-Lock's molded 90° ell covers, 12 stock covers can be adapted to 51 different sizes of iron pipe and copper tubing. Other sizes and types of fitting covers are being added regularly. For sizes for which molds are not available, Vapo-Wall fabricated fitting covers will be supplied.

Recommended Thicknesses Ambient 90F

IPS	Pipe Temperature							
	45°F	32°F	0°F	-30°F	-60°F	-120°F	-200°F	
1/2"	7/8"	1"	1"	1 1/2"	1 1/2"	2"	2"	2 1/2"
3/4"	1 1/8"	1"	1"	1 1/2"	1 1/2"	2"	2"	3"
1"	1 3/8"	1"	1"	1 1/2"	1 1/2"	2"	2 1/2"	3"
1 1/4"	1 5/8"	1"	1"	1 1/2"	2"	2"	2 1/2"	3"
1 1/2"	2 1/8"	1"	1"	1 1/2"	2"	2"	2 1/2"	3"
2"	2 3/8"	1"	1"	1 1/2"	2"	2 1/2"	2 1/2"	3 1/2"
2 1/2"	3 1/8"	1"	1"	1 1/2"	2"	2 1/2"	3"	3 1/2"
3"	3 3/8"	1"	1 1/8"	1 1/2"	2"	2 1/2"	3"	3 1/2"
4"	4 1/8"	1"	1 1/8"	1 1/2"	2"	2 1/2"	3"	4 1/2"
5"	5 1/8"	1"	1 1/2"	2"	2"	2 1/2"	3"	3 1/2"
6"	6 1/8"	1"	1 1/2"	2"	2"	2 1/2"	3 1/2"	4"
7"		1"	1 1/2"	2"	2 1/2"	3"	3 1/2"	4"
8"		1"	1 1/2"	2"	2 1/2"	3"	3 1/2"	4"
10"		1"	1 1/2"	2"	2 1/2"	3"	3 1/2"	4 1/2"
12"		1 1/2"	1 1/2"	2"	2 1/2"	3"	3 1/2"	4 1/2"
14"		1 1/2"	1 1/2"	2"	2 1/2"	3"	3 1/2"	4 1/2"
18"		1 1/2"	1 1/2"	2"	2 1/2"	3"	3 1/2"	4 1/2"
24"		1 1/2"	1 1/2"	2"	2 1/2"	3"	4"	5"
30"		1 1/2"	1 1/2"	2"	2 1/2"	3"	4"	5"
1/2"	7/8"	1"	1 1/8"	1 1/2"	2"	2 1/2"	3"	3 1/2"
3/4"	1 1/8"	1"	1 1/8"	1 1/2"	2"	2 1/2"	3"	3 1/2"
1"	1 3/8"	1"	1 1/2"	2"	2"	2 1/2"	3"	3 1/2"
1 1/4"	1 5/8"	1"	1 1/2"	2"	2"	2 1/2"	3"	4"
1 1/2"	2 1/8"	1"	1 1/2"	2"	2 1/2"	3"	3 1/2"	4"
2"	2 3/8"	1"	1 1/2"	2"	2 1/2"	3"	3 1/2"	4"
2 1/2"	3 1/8"	1 1/8"	1 1/2"	2"	2 1/2"	3"	3 1/2"	4 1/2"
3"	3 3/8"	1 1/8"	1 1/2"	2"	2 1/2"	3"	3 1/2"	4 1/2"
4"	4 1/8"	1 1/8"	1 1/2"	2"	2 1/2"	3"	4"	4 1/2"
5"	5 1/8"	1 1/2"	2"	2 1/2"	3"	3 1/2"	4"	5"
6"	6 1/8"	1 1/2"	2"	2 1/2"	3"	3 1/2"	4"	5"
7"		1 1/2"	2"	2 1/2"	3"	3 1/2"	4"	5"
8"		1 1/2"	2"	2 1/2"	3"	3 1/2"	4 1/2"	5 1/2"
10"		1 1/2"	2"	2 1/2"	3"	3 1/2"	4 1/2"	5 1/2"
12"		1 1/2"	2"	2 1/2"	3"	3 1/2"	4 1/2"	6"
14"		1 1/2"	2"	2 1/2"	3"	3 1/2"	4 1/2"	6"
18"		1 1/2"	2"	2 1/2"	3 1/2"	4"	5"	6"
24"		1 1/2"	2"	2 1/2"	3 1/2"	4"	5"	6"
30"		1 1/2"	2"	2 1/2"	3 1/2"	4"	5"	6 1/2"
1/2"	7/8"	1 1/2"	1 1/2"	2"	2 1/2"	3"	3 1/2"	4 1/2"
3/4"	1 1/8"	1 1/2"	1 1/2"	2"	2 1/2"	3"	4"	4 1/2"
1"	1 3/8"	1 1/2"	1 1/2"	2"	2 1/2"	3"	3 1/2"	4"
1 1/4"	1 5/8"	1 1/2"	1 1/2"	2"	2 1/2"	3"	3 1/2"	4"
1 1/2"	2 1/8"	1 1/2"	1 1/2"	2"	2 1/2"	3"	3 1/2"	4 1/2"
2"	2 3/8"	1 1/2"	2"	2 1/2"	3"	3 1/2"	4 1/2"	5 1/2"
2 1/2"	3 1/8"	2"	2"	2 1/2"	3"	3 1/2"	4"	5"
3"	3 3/8"	2"	2"	2 1/2"	3"	3 1/2"	4"	5"
4"	4 1/8"	2"	2 1/2"	3"	3 1/2"	4"	5"	6 1/2"
5"	5 1/8"	2"	2 1/2"	3 1/2"	4"	4 1/2"	5 1/2"	6 1/2"
6"	6 1/8"	2"	2 1/2"	3 1/2"	4"	5"	6"	7"
7"		2"	2 1/2"	3 1/2"	4"	5"	6"	7"
8"		2"	2 1/2"	3 1/2"	4"	5"	6"	7 1/2"
10"		2"	2 1/2"	3 1/2"	4 1/2"	5"	6"	7 1/2"
12"		2"	2 1/2"	3 1/2"	4 1/2"	5"	6"	7 1/2"
14"		2"	2 1/2"	3 1/2"	4 1/2"	5 1/2"	6 1/2"	8"
18"		2"	3"	4"	4 1/2"	5 1/2"	6 1/2"	8 1/2"
24"		2"	3"	4"	4 1/2"	5 1/2"	7"	9"
30"		2"	3"	4"	5"	6"	7 1/2"	9"

NOTE: Thicknesses recommended are for prevention of condensation under the above conditions. Relative humidity of 85% is a practical design condition for outdoor installations. Areas which normally experience a high-humidity climate, however, should use 90% relative as the design condition. For complete information and free consultation on your specific problem, contact your Vapo-Lock distributor.

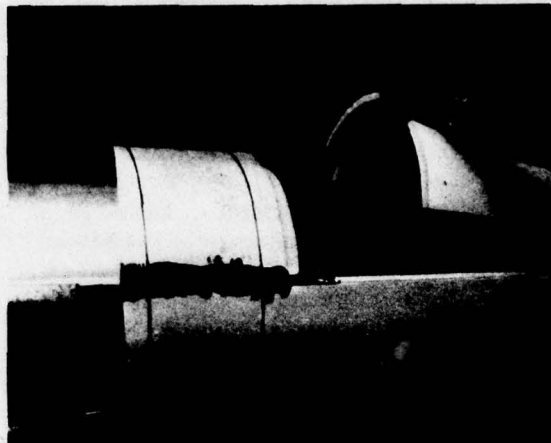
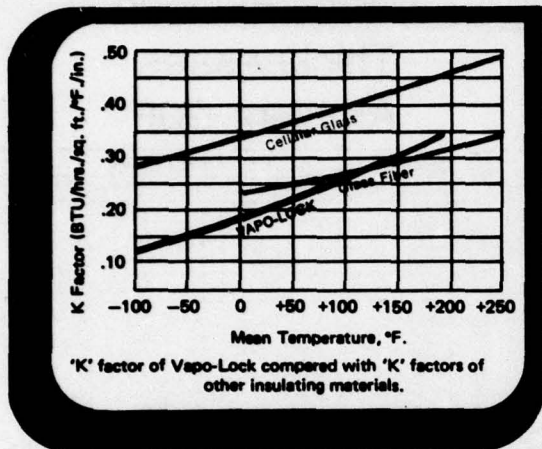

Insulation must be self-extinguishing in accordance with A.S.T.M. Test D-1692-59T and be equal to VAPO-LOCK® as manufactured by Insuldyne Corporation.

All Pipe fitting insulation shall be molded or fabricated of the same expanded polystyrene material. Shop fabricated fittings shall be equal in appearance and performance to molded insulation.

NOTE: These are general suggested specifications covering the most widely used set of conditions. Final selection of materials and application methods must be made by the design engineer to meet specific needs.

Insuldyne Corporation

Insuldyne Corporation is a manufacturing organization providing insulation contractors as well as industry with the finest in insulation products, accessory items and service. Insuldyne Corporation specializes in foam plastic products, both molded and fabricated products of polyurethane,

styrofoam, expanded polystyrene, foamed polyethylene and cellular glass. Hot insulation materials of calcium silicate, fibrous glass and mineral wool are also fabricated to exacting standards for industry. Insuldyne Corporation manufactured items can be found throughout the world.

Insuldyne Corporation

255 LOTTMAN • P. O. BOX 52566 • HOUSTON, TEXAS 77052 • (713) 222-1328

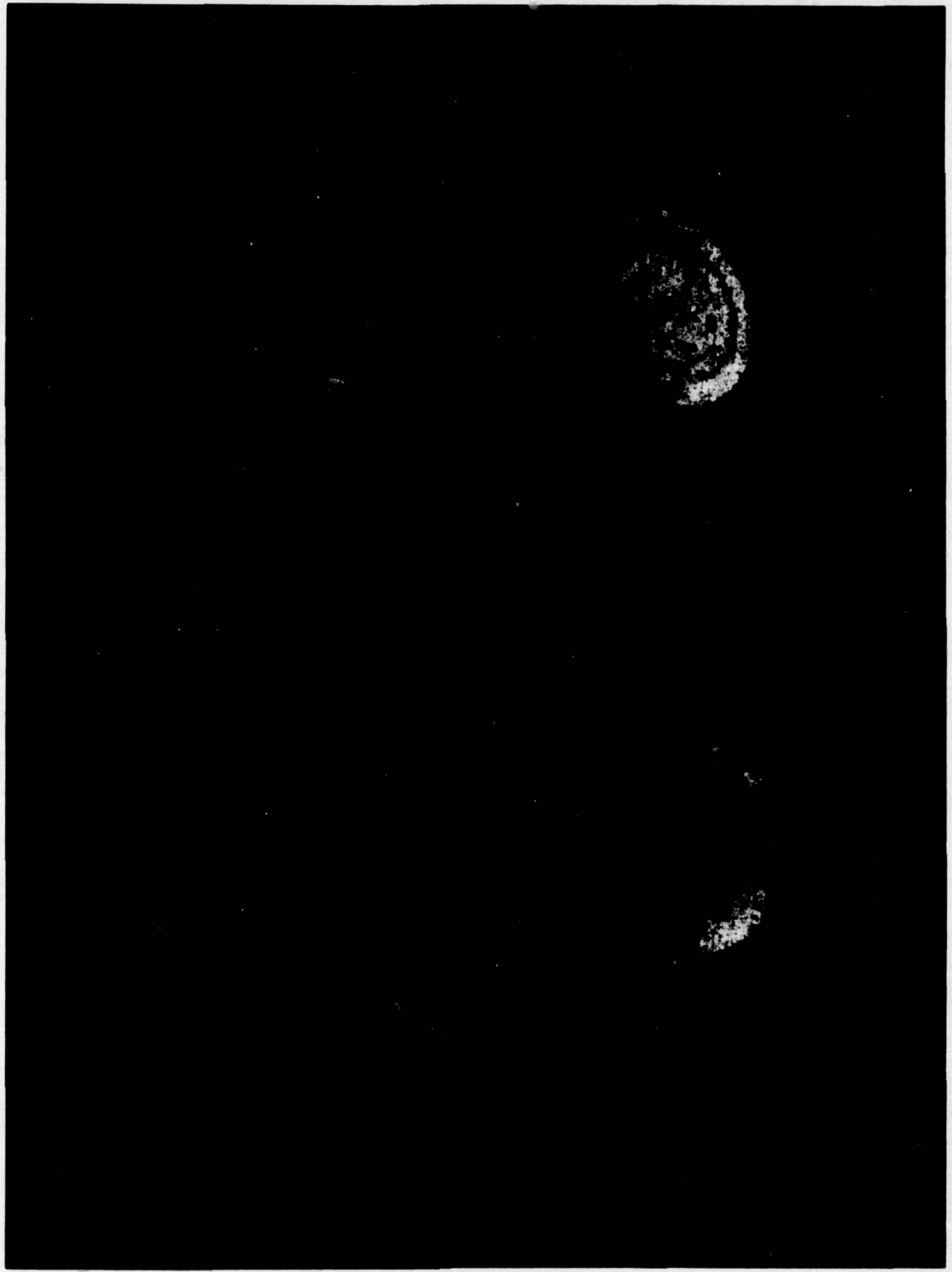

FIG. 1 POLYSTYRENE PACKAGE COMPONENTS.

C-41

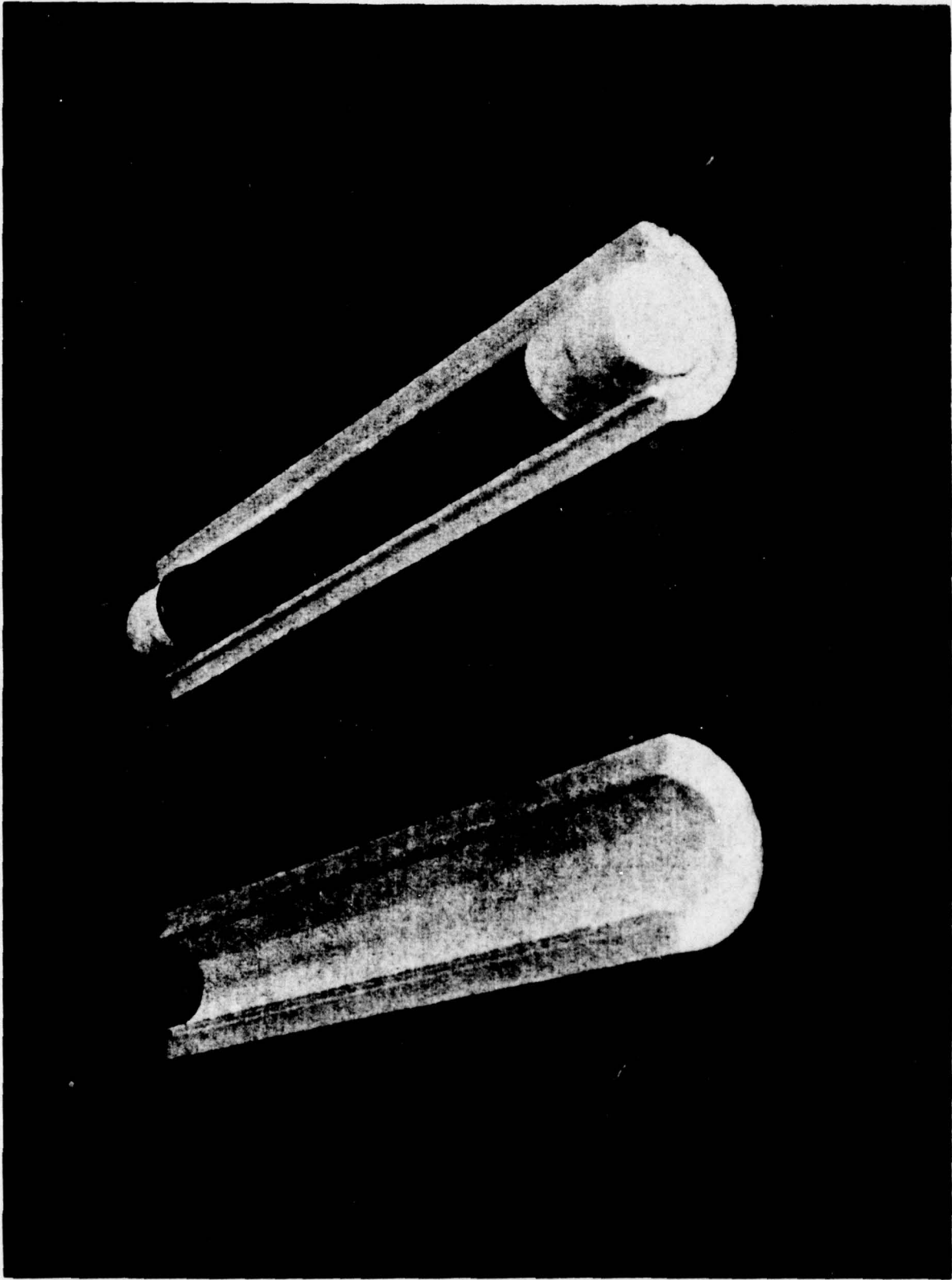

FIG. 2 76mm CARTRIDGE IN PLACED IN PACKAGE.

C-42

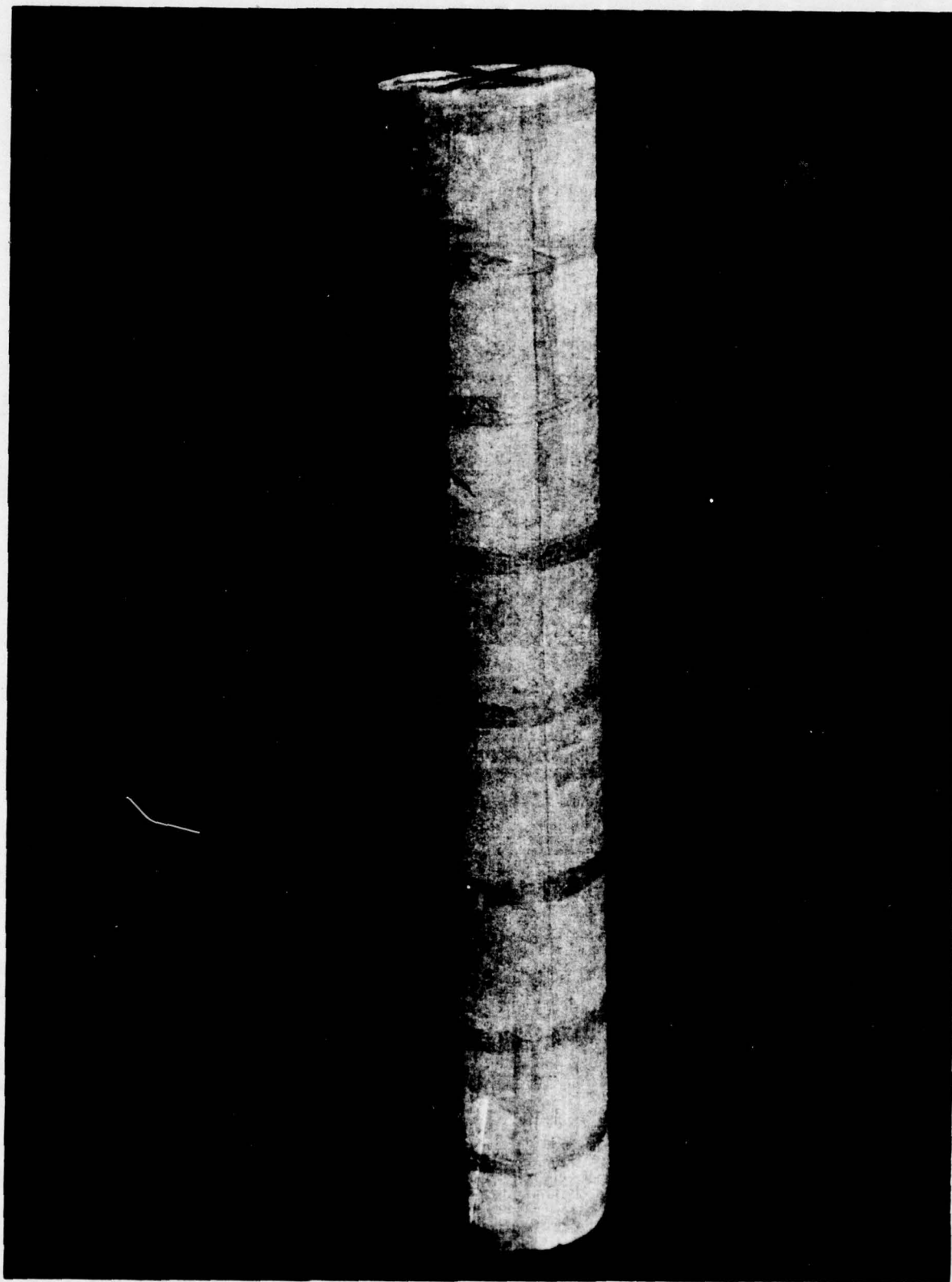

FIG. 3 COMPLETED PACKAGE.

C-43

INSULDYNE CORPORATION

P.O. BOX 52566
HOUSTON, TEXAS 77052
(713) 222-1328

FOAM PLASTIC PIPE INSULATION PRODUCTS

VAPO-LOCK - URETHANE - STYROFOAM

L I S T P R I C E S

PIPE SIZES		WALL THICKNESSES						
IPS	Copper Tubing	Single Layer			Mult. Layer			
		STANDARD STOCK SIZES			2½"	3"	3½"	4"
		1"	1½"	2"				
1/2"	5/8"	\$0.75	\$1.60	\$2.55	\$3.00	\$3.60	\$5.55	\$7.25
3/4"	7/8"	.85	1.65	2.65	3.15	4.05	5.65	7.35
1"	1-1/8"	.90	1.75	2.80	3.30	4.20	6.00	7.80
1-1/4"	1-3/8"	1.00	1.90	3.00	3.45	4.35	6.20	8.00
1-1/2"	1-5/8"	1.10	2.00	3.15	3.60	4.65	6.35	8.15
2"	2-1/8"	1.20	2.20	3.30	3.75	4.95	6.60	8.40
2-1/2"	2-5/8"	1.35	2.40	3.55	4.05	5.25	6.95	8.65
3"	3-1/8"	1.50	2.50	3.80	4.50	5.70	7.40	9.35
3-1/2"	3-5/8"	1.65	2.70	4.10	4.95	6.15	7.70	9.65
4"	4-1/8"	1.95	2.85	4.40	5.40	6.60	8.45	10.40
5"	5-1/8"	2.25	3.20	5.00	6.30	7.50	9.20	11.60
6"	6-1/8"	2.40	3.30	5.10	6.75	8.10	9.90	12.30
7"		2.85	3.60	5.55	7.20	8.70	10.80	13.20
8"		3.30	4.05	6.00	7.65	9.45	11.70	14.10
9"		3.60	4.50	6.60	8.40	10.20	12.60	15.60
10"		3.90	4.95	7.20	9.15	10.95	13.95	16.65
11"		4.20	5.25	7.65	9.60	11.70	14.70	17.55
12"		4.50	5.55	8.10	10.20	12.30	15.45	18.45
14"			6.30	9.00	11.40	13.80	16.65	19.80
16"			7.05	9.90	12.60	15.30	18.45	21.90
18"			7.80	10.80	13.80	16.80	20.25	23.70
20"			8.55	12.00	15.00	18.00	21.75	25.50
22"			9.30	12.90	16.20	19.50	23.40	27.45
24"			9.90	13.50	17.25	21.00	25.05	28.95

NOTE: For 4# density hanger insulation, double the above list and use applicable discount.

Fabricated tongue and groove pipe insulation, add \$1.15 per linear foot.

SEE APPLICABLE DISCOUNT SHEET.

INSULDYNE CORPORATION

P.O. BOX 52566
HOUSTON, TEXAS 77052
(713) 222-1328

VAPO-LOCK MOLDED POLYSTYRENE ELL COVERS

Vapo-Lock ell covers are made in two styles - "Composite", which fits over several sizes of pipe and tubing ells; and "Exact", which fits over only one size. The table below gives the various welded ell sizes for which exact ell covers are made, as well as the ells which each composite size will cover. The "Composite" style is illustrated in our brochure.

LIST PRICE PER ELL			
COVER SIZES	WALL THICKNESSES		
	1"	1-1/2"	2"
Exact Size 1/2" IPS Weld Ell	\$1.65	\$1.95	N.A.
Exact Size 3/4" IPS Weld Ell	1.65	1.95	N.A.
Composite Size #1			
1/2" IPS 7/8" CT	\$1.80	\$2.05	\$3.60
3/4" IPS 1-1/8" CT			
1" IPS 1-3/8" CT			
Exact Size 1-1/2" IPS Weld Ell	2.40	3.00	N.A.
Composite Size #2	\$2.70	\$3.60	\$4.80
1-1/4" IPS 1-5/8" CT			
1-1/2" IPS 2-1/8" CT			
2" IPS			
Exact Size 2" IPS Weld Ell			
Composite Size #3	\$3.00	\$4.50	N.A.
2-1/2" IPS 2-5/8" CT			
3" IPS 3-1/8" CT			
3" IPS 3-5/8" CT			
Exact Size 3" IPS Weld Ell 3-5/8" CT			
Exact Size 4" IPS Long Radius Weld Ell Only	\$4.80	\$6.30	\$10.50

SEE APPLICABLE DISCOUNT SHEET.

Sheet No. : IC-101
Page No. : 1 of 1
Date : 5-1-74
Supersedes: 1-1-74

INSULDYNE CORPORATION

P.O. BOX 52566
HOUSTON, TEXAS 77052
(713) 222-1328

VAPO-LOCK - URETHANE - STYROFOAM FABRICATED FITTINGS THRU 300# PRESSURE RATING

LIST PRICES

IPS	1" NOMINAL THICKNESS			1-1/2" NOMINAL THICKNESS		
	Screwed, Weld & Sweat Fittings	FLANGED FITTINGS Flanges	Valves, Ells, Tees, Reducers	Screwed, Weld & Sweat Fittings	FLANGED FITTINGS Flanges	Valves, Ells, Tees, Reducers
1/2"	\$ 2.00	\$ 3.30	\$ 12.25	\$ 2.50	\$ 3.80	\$ 13.90
3/4"	2.00	3.60	12.25	2.50	4.50	13.90
1"	2.10	4.05	12.25	2.90	4.75	13.90
1-1/4"	2.45	4.65	13.00	3.20	4.85	15.50
1-1/2"	2.50	4.75	13.60	3.45	4.95	16.00
2"	2.70	4.85	15.00	4.30	5.15	18.37
2-1/2"	3.00	5.65	18.40	4.80	6.00	21.75
3"	3.90	7.15	21.75	6.30	9.25	26.75
3-1/2"	5.30	8.70	26.75	7.50	10.15	28.75
4"	5.50	10.00	28.75	9.00	11.35	33.50
5"	8.90	10.25	33.50	12.50	11.70	41.75
6"	14.00	10.50	41.75	17.50	12.05	50.00
8"	18.75	17.50	57.50	26.25	20.00	66.75
10"	26.25	21.90	82.50	35.00	25.00	101.25
12"	32.50	26.25	100.00	43.75	35.00	117.50
14"				50.00	47.50	150.25
16"				62.50	57.50	183.50
18"				75.00	63.75	216.75
20"				93.75	66.70	250.00
24"				110.00	83.50	280.00

NOT AVAILABLE IN SIZES ABOVE 12" IPS IN 1" NOMINAL THICKNESS.

SEE APPLICABLE DISCOUNT SHEET.

Sheet No. : IC-102
Page No. : 1 of 4
Date : 5-1-74
Supersedes: 1-1-74

INSULDYNE CORPORATION

P.O. BOX 52566
HOUSTON, TEXAS 77052
(713) 222-1328

VAPO-LOCK - URETHANE - STYROFOAM FABRICATED FITTINGS THRU 300# PRESSURE RATING

LIST PRICES

IPS	2" NOMINAL THICKNESS			2-1/2" NOMINAL THICKNESS		
	Screwed, Weld & Sweat Fittings	FLANGED FITTINGS Flanges	Valves, Ells, Tees, Reducers	Screwed, Weld & Sweat Fittings	FLANGED FITTINGS Flanges	Valves, Ells, Tees, Reducers
1/2"	\$ 3.75	\$ 3.75	\$ 18.37	\$ 4.90	\$ 5.60	\$ 22.00
3/4"	3.75	4.65	18.37	4.90	7.25	22.00
1"	4.12	6.55	18.37	5.50	8.50	22.00
1-1/4"	4.87	6.65	20.50	5.75	8.90	26.20
1-1/2"	5.00	6.80	22.00	6.25	9.00	28.50
2"	5.75	7.55	23.90	7.25	9.50	30.00
2-1/2"	7.50	7.80	26.50	8.75	9.75	33.50
3"	8.75	8.85	27.90	11.25	11.50	41.25
3-1/2"	10.00	10.50	31.50	13.75	14.25	44.25
4"	11.40	11.25	35.00	15.80	16.25	46.00
5"	15.60	12.20	44.00	18.30	19.25	55.00
6"	20.00	14.25	50.40	24.00	20.60	75.00
8"	28.75	23.00	65.00	35.00	31.25	95.00
10"	45.00	30.60	108.00	50.00	33.75	125.00
12"	52.50	41.25	115.20	62.50	50.00	153.75
14"	62.50	50.00	145.00	70.00	55.00	197.50
16"	75.00	55.50	175.00	90.00	72.50	237.75
18"	90.00	61.25	201.60	105.00	77.50	252.00
20"	105.00	70.00	230.00	122.50	88.75	275.00
24"	128.00	85.00	300.00	150.00	110.00	362.50

SEE APPLICABLE DISCOUNT SHEET.

Sheet No. : IC-102
Page No. : 2 OF 4
Date : 5-1-74
Supersedes: 1-1-74

INSULDYNE CORPORATION

P.O. BOX 52566
HOUSTON, TEXAS 77052
(713) 222-1328

VAPO-LOCK - URETHANE - STYROFOAM FABRICATED FITTINGS THRU 300# PRESSURE RATING

LIST PRICES

IPS	3" NOMINAL THICKNESS			3-1/2" NOMINAL THICKNESS		
	Screwed, Weld & Sweat Fittings	FLANGED FITTINGS Flanges	Valves, Ells, Tees, Reducers	Screwed, Weld & Sweat Fittings	FLANGED FITTINGS Flanges	Valves, Ells, Tees, Reducers
1/2"	\$ 5.75	\$ 6.25	\$ 28.00	\$ 8.75	\$ 9.40	\$ 28.00
3/4"	6.00	7.50	28.00	10.00	10.00	28.00
1"	6.75	9.50	28.00	11.00	11.00	28.00
1-1/4"	7.90	10.00	32.80	11.25	11.50	47.50
1-1/2"	8.10	10.40	35.50	11.50	12.50	50.00
2"	9.50	10.80	40.00	14.50	13.50	52.00
2-1/2"	11.50	14.30	47.20	16.50	15.75	54.50
3"	15.25	15.30	53.75	19.25	16.90	58.00
3-1/2"	16.80	17.80	55.00	22.75	20.40	60.00
4"	18.50	20.75	57.50	24.75	23.75	75.00
5"	23.50	23.10	72.00	28.75	26.50	82.50
6"	30.00	26.50	79.25	35.75	31.25	88.00
8"	40.00	33.00	112.50	46.75	40.00	132.00
10"	65.00	43.00	140.00	76.25	50.50	175.00
12"	75.00	57.50	170.00	90.00	58.75	201.25
14"	88.00	61.50	220.00	110.00	63.25	275.00
16"	110.00	77.50	275.00	126.25	88.75	320.00
18"	120.00	85.00	300.00	138.75	94.00	350.00
20"	145.00	98.50	332.50	166.25	103.75	390.00
24"	195.00	117.50	425.00	220.00	122.50	490.00

SEE APPLICABLE DISCOUNT SHEET.

Sheet No. : IC-102
Page No. : 3 of 4
Date : 5-1-74
Supersedes : 1-1-74

INSULDYNE CORPORATION

P.O. BOX 52566
HOUSTON, TEXAS 77052
(713) 222-1328

VAPO-LOCK FABRICATED FITTINGS Description of Fitting Prices

SCREWED, WELD, SWEAT :

Ells, Tees, Reducers, Caps. Weld and Sweat - All Pressures.
Screwed and Socket Weld Thru 2000# Pressure.

FLANGED VALVES, ELLS, TEES, REDUCERS :

Gate, Globe and Check Valves.

ADDITION FOR SPECIAL FITTINGS

Increase Net Price by Percentage Shown

	<u>Screwed and Socket-Weld</u>	<u>FLANGES</u>	
		<u>Flanges</u>	<u>Tees, Reducers Valves, Ells</u>
3000#	25%		
6000#	50%		
400#		5%	25%
600#		10%	35%
900#		50%	150%
1500#		100%	275%
2500#		150%	Price on Request
Blind Flange		50%	
Orifice Flange		50%	
Crosses - Y's	50%		50%
Traps - Strainers	100%		100%
Control, Relief			50%
Regulating, Safety			50%
2-Way Plug			35%
3-Way Plug			70%
Bolted Bonnet			Less 20%
Screwed or Weld End			less 50%
Union or Screw Bonnet			Less 50%

SPECIAL FITTINGS

Sheet No. : IC-102
 Sheet No. : IC-120
 Page No. : 4 of 4
 Date : 1-1-74

MEMORANDUM

WH-8051-HT:ck
4 November 1971

From: Code 8051 (T&E)

To: Code 8021 (ED)

Subj: Test and Evaluation of 5"/54 Plastic Cartridge Tanks, Self-
Extinguishing

1. In accordance with request from 8021 (J. Sycle), polyethylene cartridge tanks manufactured from 4 different plastic materials were subjected to rough-handling tests while at temperature extremes of +140° F and -25° F. Memo Report TE ORD 11-10-71 is attached.
2. The subject tanks all failed the cold environmental test at -25° F. Three out of four samples were satisfactory at +140° F.

Copy to:

80A/805 (M. Gray/R. Seely)
802 (L. Caringi)
803 (A. Harmsen)
8051 (T&E File)

NAVAL AMMUNITION DEPOT EARLE
NAVAL WEAPONS HANDLING LABORATORY

Memo Report TE ORD 11-10-71
Project No. 9 507 101 54
November 1971

TEST AND EVALUATION
OF
5"/54 PLASTIC CARTRIDGE TANKS, SELF-EXTINGUISHING

INTRODUCTION

Previous testing indicated that a molded polyethylene tank would satisfactorily contain the 5"/54 cartridge. A promising unit load tested was described in Memo Report TE ORD 10-10-70. This load lacked complete approval due to non-compliance of the plastic material to meet the self-extinguishing flammability tests of Federal Test Standard 406 Method 2021 and rough-handling tests at extreme temperatures. Four flame-inhibiting types of polyethylene were molded into tanks and subjected to handling tests at the temperature extremes of +140° F and -25° F.

DESCRIPTION

Four plastic materials had been blow-molded into cartridge tanks for 5"/54 projectiles at the K and M Rubber Company at Elk Grove Village, Illinois. The plastics were basically polyethylene with

flame-retardant ingredients. One was a slow-burning grade and three others were (S.E.) experimental, self-extinguishing polyethylene. Previous testing showed the flammability characteristics to be as follows:

Lot 1 - No. 853 - Flamolin Polyethylene - Raychem Co. - S.E. non-drip

Lot 2 - No. 7002-2 APD-749 - Polyethylene - Sinclair-Koppers - S.E.

with non-flaming drip

Lot 3 - No. 210-730A - Polyethylene - Allied Chemical - S.E. with

non-flaming drip

Lot 4 - No. A6020P - Polyethylene - Celanese - slow-burning

Comparison of the metal tank and the plastic tank is shown in Figure 1 attached. The tank, complete with its cap including the male and female screw threads, is blow-molded in one unit. After this, the gate section between the body and cap is cut out and removed. A cut-away molded tank is shown in Figure 2. A 5"/54 cartridge is shown being installed in the plastic tank (Figure 3).

TEST PROCEDURE AND RESULTS

To test the serviceability of the plastic tank for use as a cartridge tank a drop test as specified in paragraph 4.2.5.2.4 of MIL-T-18652 was performed. Prior to this test, each test tank was loaded with a 5"/54 cartridge weighing 32.5 lbs. All the tanks were

allowed to be conditioned thoroughly at first one temperature extreme "A" at +140° F and then at another extreme "B" at -25° F. The procedure and results are listed below:

Five plastic tanks of each of the four non-flammable characteristics were inert loaded with the 5"/54 cartridge. Each of these tanks was dropped from a height of three feet, four times, to a concrete surface to land initially on bottom edge, top edge, top and bottom edges simultaneously and the top and bottom edge simultaneously, 180 degrees from the preceding position. Each tank was then placed in a vertical position, top uppermost, and toppled over to land on a piece of lumber having a cross section of 4 x 4 inches and to strike the tank approximately ten inches from the top. One sample of each tank tested is shown in Figure 4.

RESULTS

Condition "A" at +140° F.

Lot 1 - No. 853 - Flamolin Polyethylene by Ray Chemical. Three samples were satisfactory, the bottom end of one sample cracked and one had the bottom end broken open. See Figure 5.

Lot 2 - No. 7002-2 APD-749 - Polyethylene by Sinclair-Koppers. All five samples showed no failure.

Lot 3 - No. 210-730A - Polyethylene, by Allied Chemical. All five samples showed no cracking.

Lot 4 - No. A 6020P - Polyethylene by Celanese. All five samples showed no failure.

Condition "B" at -25° F.

Lot 1 - No. 853 - Flamolin Polyethylene by Ray Chemical. Four samples were satisfactory and one sample cracked badly.

Lot 2 - No. 7002-2 APD-749 - Polyethylene by Sinclair-Koppers. Four samples cracked badly at the base end, one sample cracked at the cap end.

Lot 3 - No. 210-730A - Polyethylene by Allied Chemical. Two samples cracked badly; three samples were satisfactory.

Lot 4 - No. A6020P - Polyethylene by Celanese. Three samples were satisfactory and two samples failed at the bottom of each container.

CONCLUSIONS

All four polyethylene plastic flame-resistant varieties of molded 5"/54 cartridge tanks failed rough-handling tests prescribed in MIL-T-18652 when the test units were subjected to exposure to -25° F until temperature saturated. None of the sample plastic varieties tested are suitable for shipping or handling the 5"/54 cartridge tank.

Test performed by RALPH MERCURIO 11/5/71

Reviewed by W. H. Thowbridge 11/5/71
J. E. Boyle 11/30/71

R. E. Seely 12/15/71

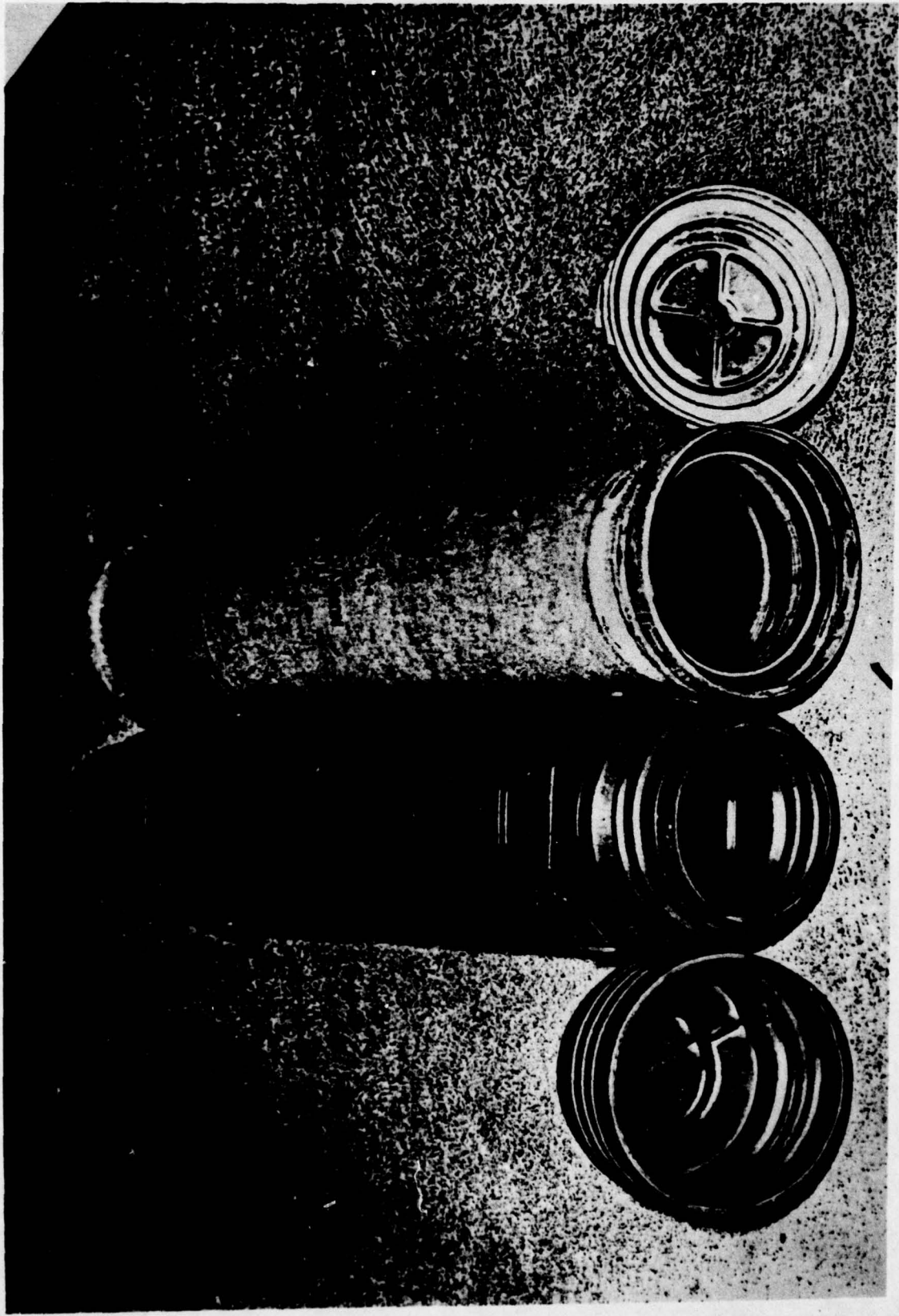
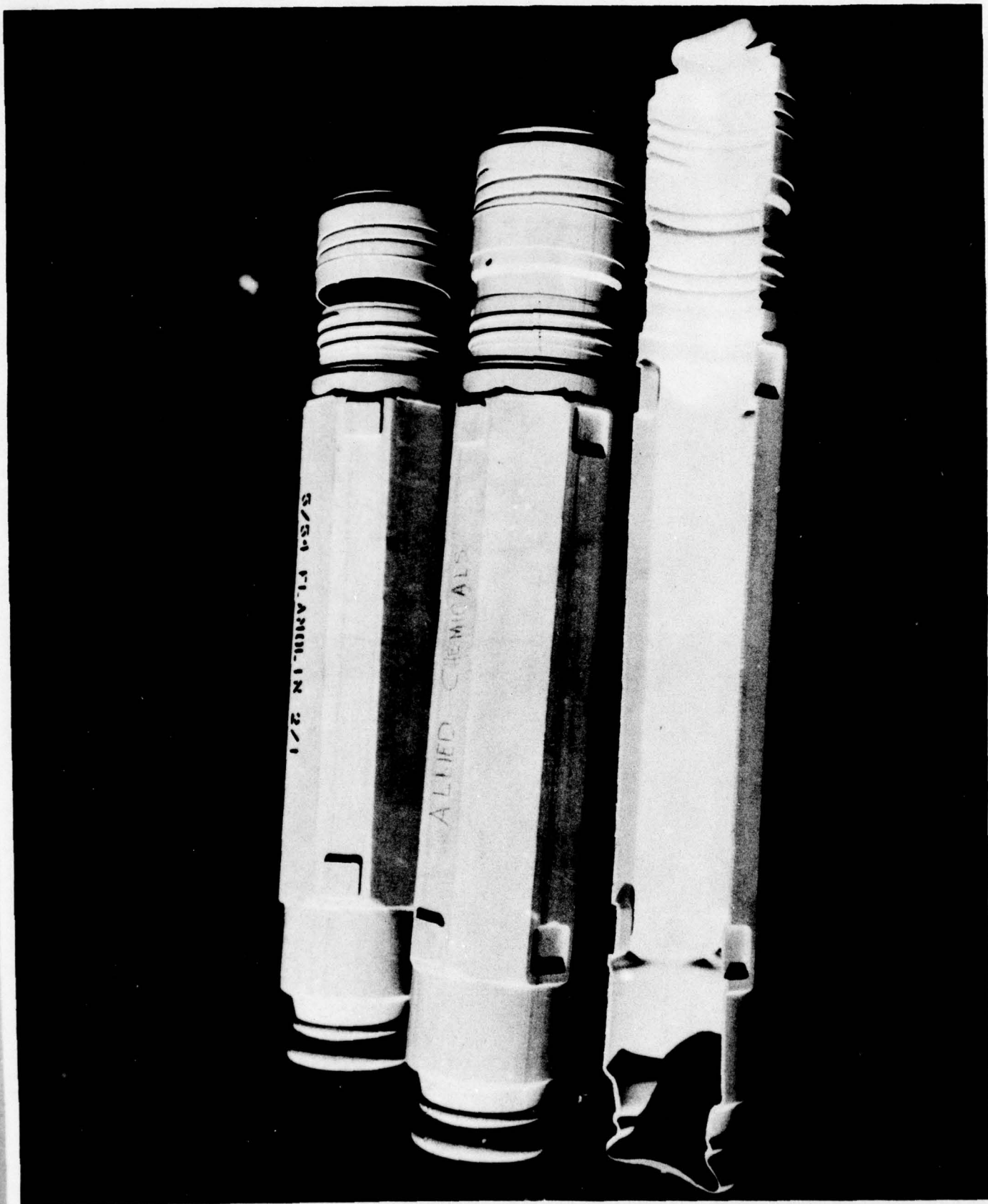

Fig. 1 Comparison of Metal Tank with Plastic Tank.
C-55



C-56



C-57



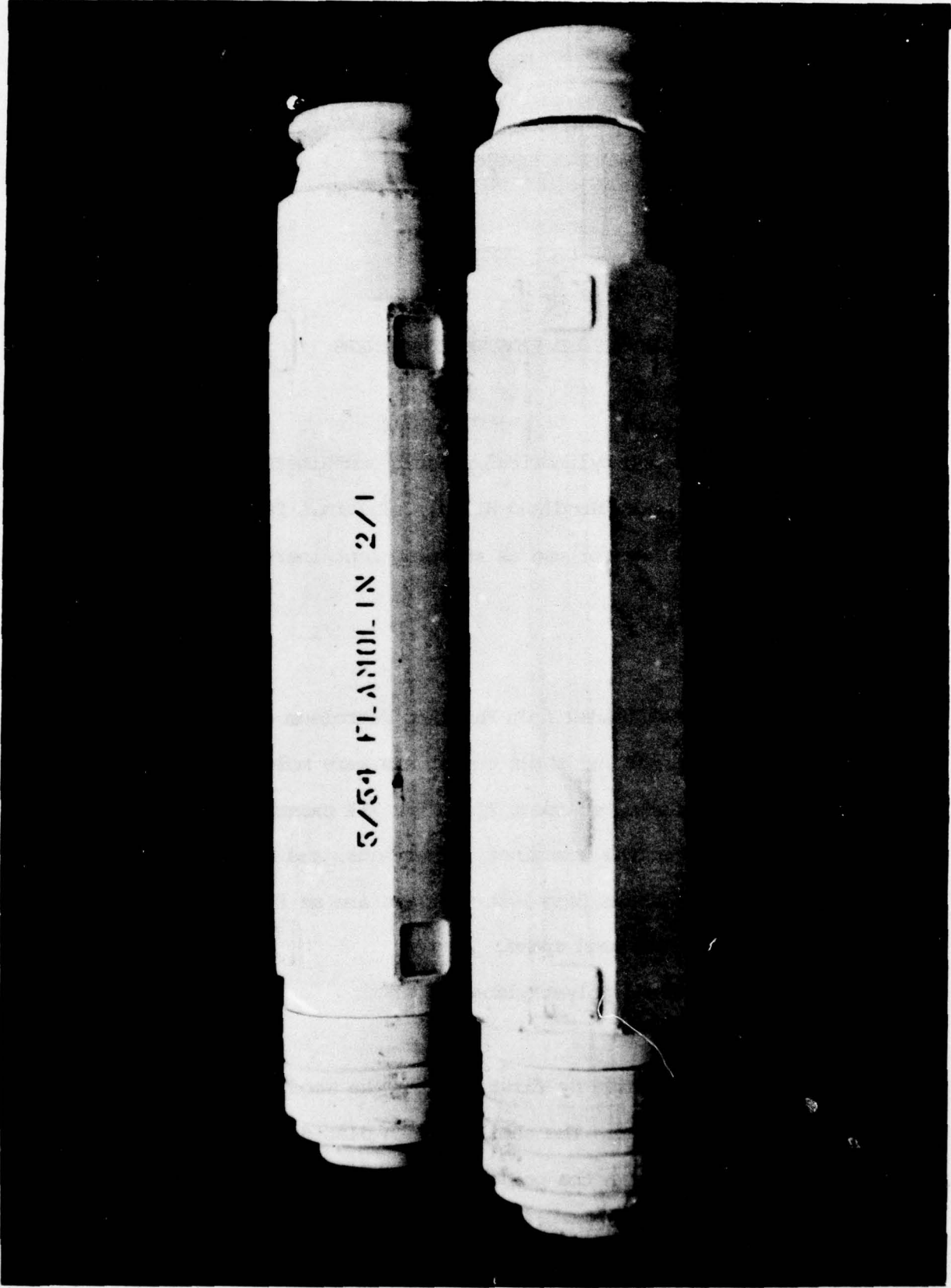

5/54 FLAMOLIN 2/1

C-59

NWHL Report 7642
28 May 1976

NAVAL WEAPONS STATION EARLE
NAVAL WEAPONS HANDLING LABORATORY

COLD DROP TESTS
OF
ROTATIONALLY MOLDED PLASTIC CONTAINERS

INTRODUCTION

Six rotationally molded cylindrical plastic containers were supplied by Hollowform Corporation of Woodland Hills, California for evaluation to determine their suitability for use as shipping containers for 76MM fixed round cartridge.

DESCRIPTION

Three containers were molded from Phillips Petroleum crosslinked slow burning polyethylene CL 100 and three containers were molded with a U.S. Industrial Chemical's flame retardent Flamoline 711 exterior and CL 100 interior. Figure 1 shows the container, components, and a 76MM round prior to assembly. The items shown from left to right are as follows:

- a. Container body and wood spacer
- b. Container cover and polyethylene spacer
- c. 76mm fixed round

The container is assembled by first placing the wood spacer in the bottom half of the container. The shell is then placed into the container. The container top cover, with the polyethylene spacer inside, slides over the upper part of the bottom container half and is taped closed.

Table I shows the material, color, wall thickness, inside diameter and gross weight of each of the six containers to be tested.

TEST PROCEDURE AND RESULTS

The six loaded containers were conditioned in an environmental chamber at a temperature of -20°F for a sixteen hour period. The containers were then subjected to a 30" drop test (free-fall) in accordance with MIL-STD-648, paragraph 5.2.3.

RESULTS: The CL 100 containers were undamaged, but two of the three Flamoline 711 containers fractured on impact.
See Figure 2 and Table I.

CONCLUSIONS

The polyethylene CL 100 container submitted is capable of withstanding a 30" free-fall drop test at a temperature of -20°F. The Flamoline 711 container fractures when subjected to this same test.

Prepared by: Ralph I. Mercurio
R. MERCURIO
Engineering Technician

Approved by: J. E. Boyle
J. E. BOYLE
Mechanical Test Branch

R. E. Seely
R. E. SEELY
Test and Evaluation Division

TABLE I

Container No.	Material	Color	Empty Container Weight	Wall Thickness (Inches)	Inside Diameter (Inches)	Gross Loaded Wt (Lbs)	Results of -20°F Drop Test (30" Height)
1	CL 100 Phillips Petro polyethylene	Black	2 LB-10 OZ	.200 to .225	4.375	28	Unbroken
2	CL 100 Phillips Petro polyethylene	Black	3 LB-14 OZ	.325 to .350	4.075	29	Unbroken
3	CL 100 Phillips Petro polyethylene	Black	5 LB- 4 OZ	.4375 to .44	4.075	31½	Unbroken
4	711 Flamoline and CL 100	White	5 LB- 4 OZ	.350	4.175	32-3/4	Broken
5	711 Flamoline and CL 100	White	5 LB- 4 OZ	.350	4.150	32½	Unbroken
6	711 Flamoline and CL 100	Black	5 LB- 4 OZ	.375	4.100	30½	Broken

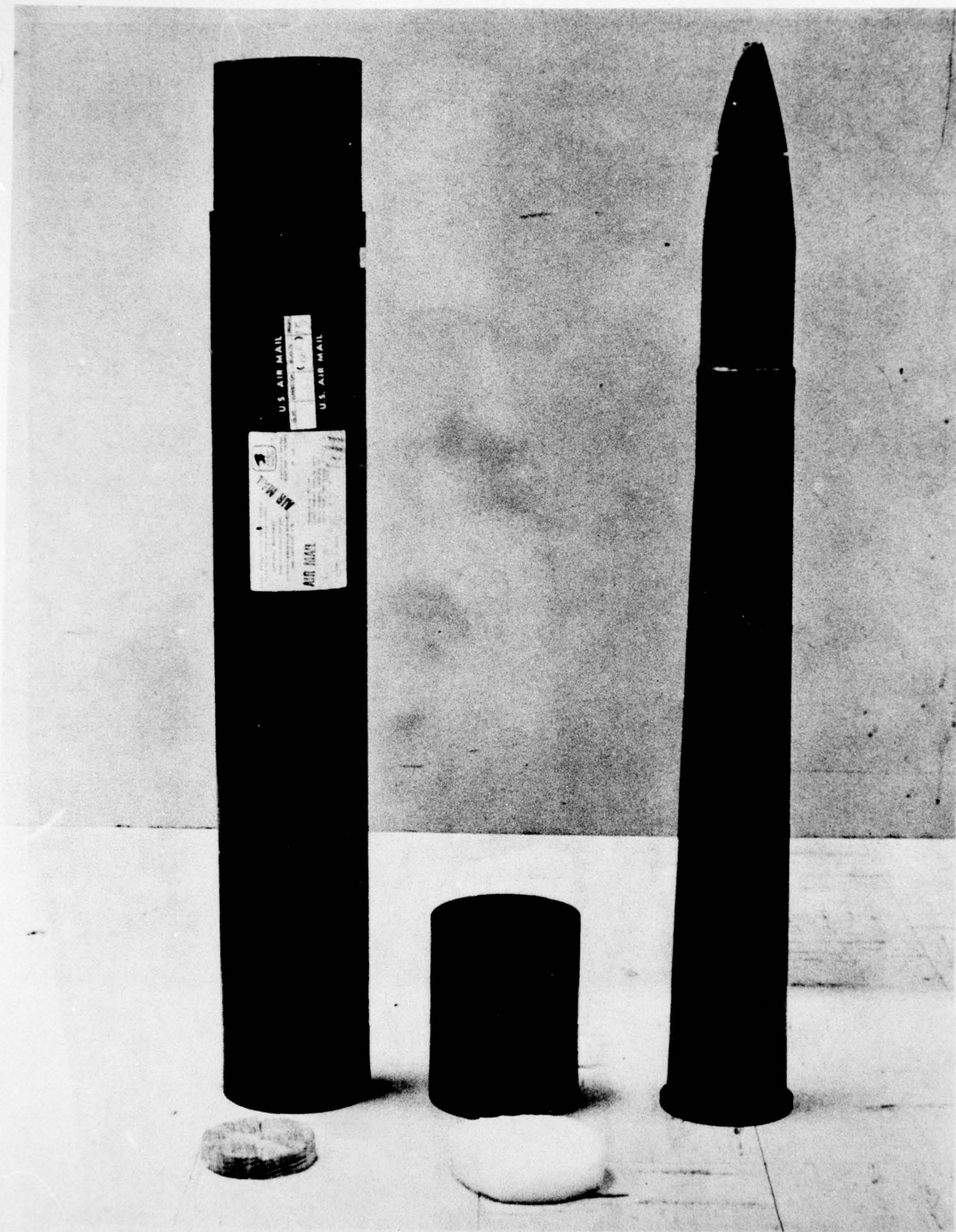

C-63



C-64

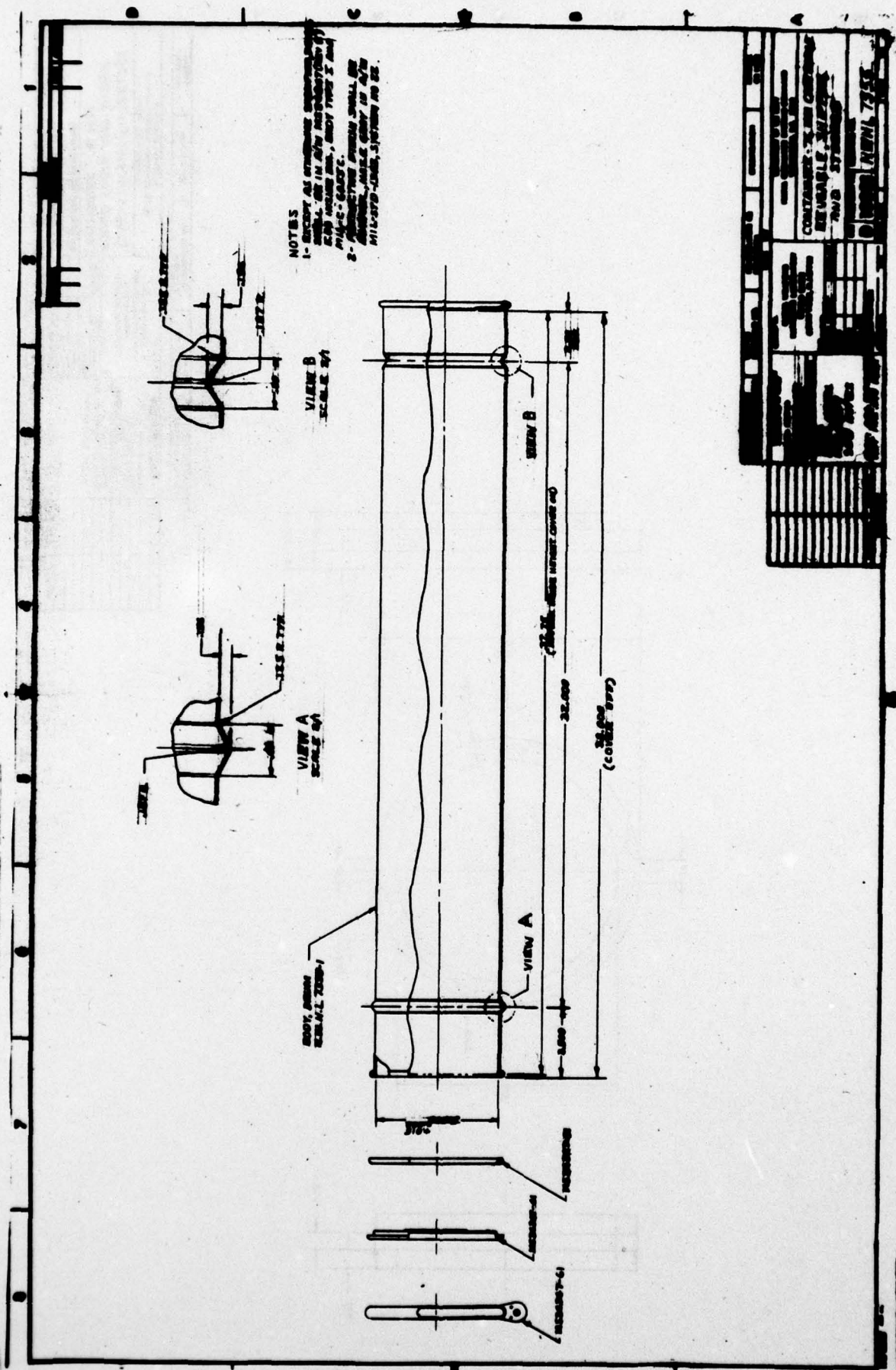

NOTES
 1- EXCEPT AS OTHERWISE SPECIFIED, ALL DIMENSIONS SHALL BE IN INCHES AND DECIMALS THEREOF.
 2- DIMENSIONS IN PARENTHESES SHALL BE IN MILLIMETERS.
 3- DIMENSIONS IN PARENTHESES SHALL BE IN MILLIMETERS AND DECIMALS THEREOF.

REV	DATE	BY	CHKD
1			
2			
3			
4			
5			
6			
7			
8			
9			
10			
11			
12			
13			
14			
15			
16			
17			
18			
19			
20			
21			
22			
23			
24			
25			
26			
27			
28			
29			
30			
31			
32			
33			
34			
35			
36			
37			
38			
39			
40			
41			
42			
43			
44			
45			
46			
47			
48			
49			
50			

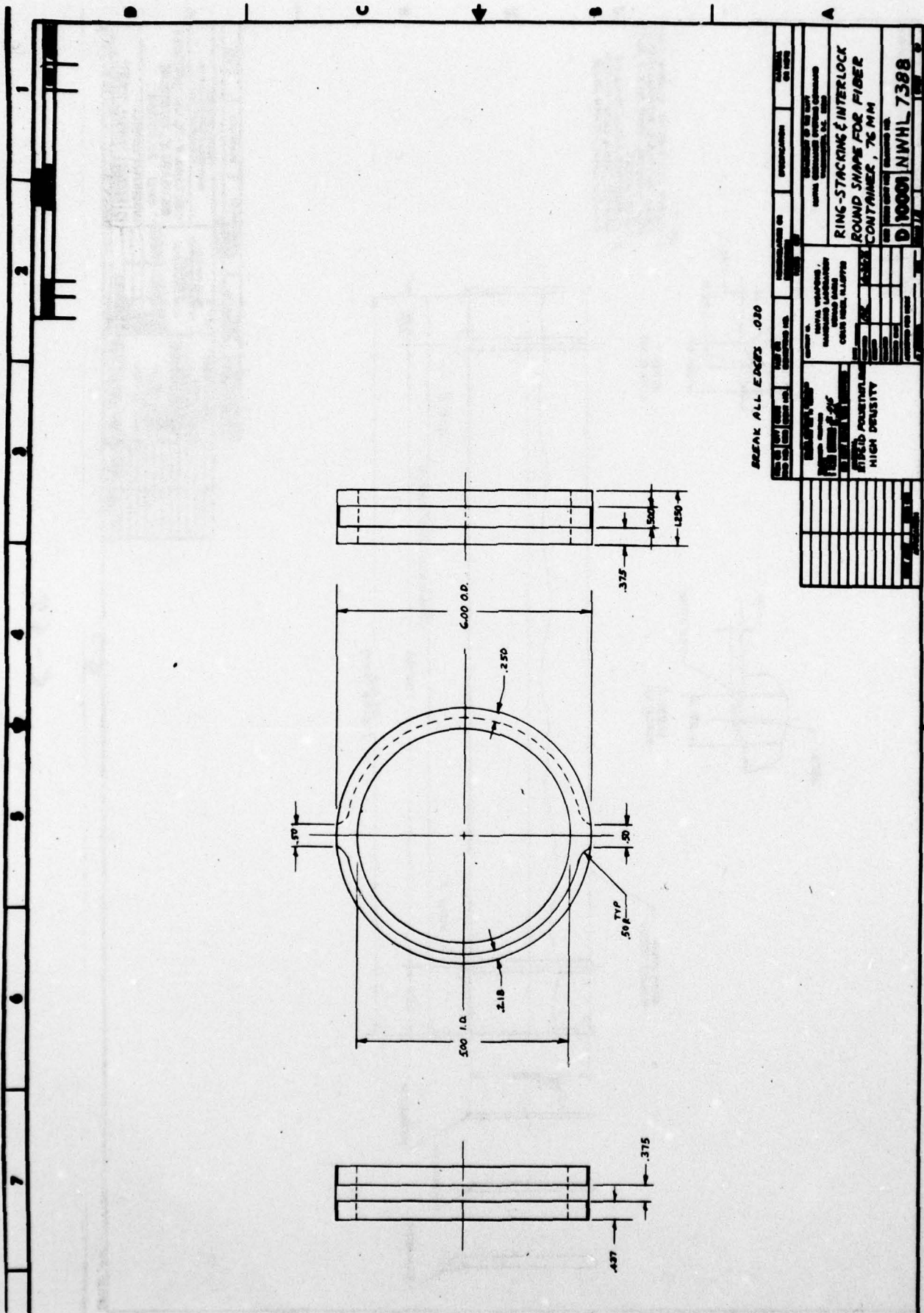

6-68

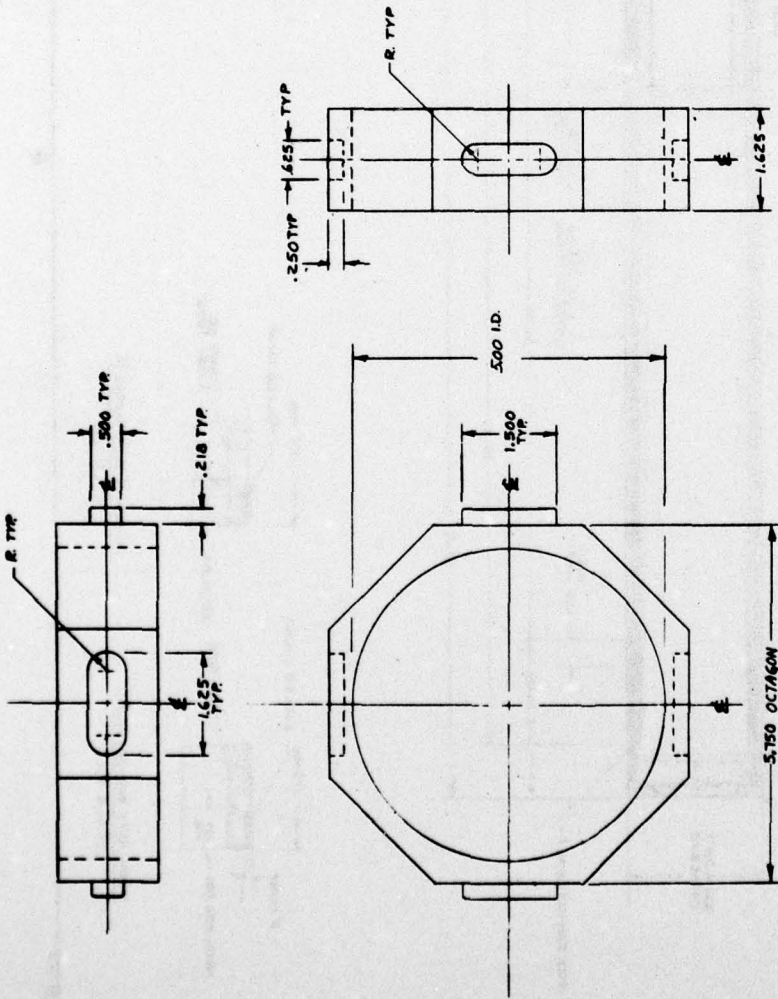

BREAK ALL EDGES .030

REV	DATE	BY	CHKD	DESCRIPTION
1				
2				
3				
4				
5				
6				
7				
8				
9				
10				
11				
12				
13				
14				
15				
16				
17				
18				
19				
20				
21				
22				
23				
24				
25				
26				
27				
28				
29				
30				
31				
32				
33				
34				
35				
36				
37				
38				
39				
40				
41				
42				
43				
44				
45				
46				
47				
48				
49				
50				
51				
52				
53				
54				
55				
56				
57				
58				
59				
60				
61				
62				
63				
64				
65				
66				
67				
68				
69				
70				
71				
72				
73				
74				
75				
76				
77				
78				
79				
80				
81				
82				
83				
84				
85				
86				
87				
88				
89				
90				
91				
92				
93				
94				
95				
96				
97				
98				
99				
100				

RING- STACKING & INTERLOCK
OCTAGON SHAPE FOR FIBER
CONTAINER, 76 PIN

D 10001 NWHL 7387

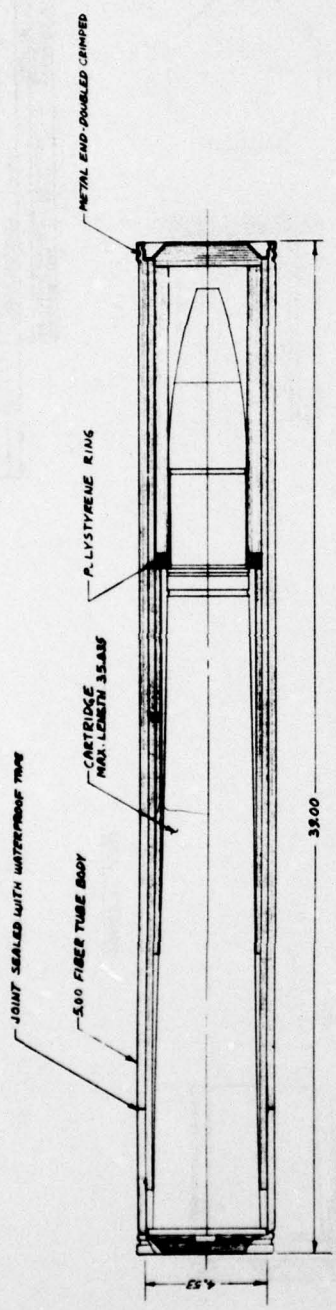

CONCEPT 2A

NOTES
 1- ROUND CONTAINERS CAN BE STACKED VERTICALLY WITH ADAPTERS FOR PALLETIZED UNIT LOADS (MAX HEIGHT 48")
 2- CONTAINERS WITH OCCASIONAL INTERLOCK RINGS CAN BE STACKED HORIZONTALLY WITH ADAPTERS FOR PALLETIZED UNIT LOADS.

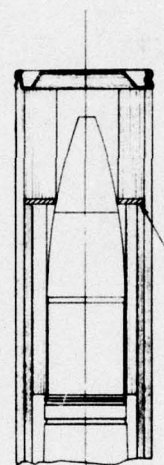

CONCEPT 2B

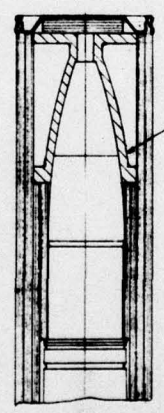

CONCEPT 2C

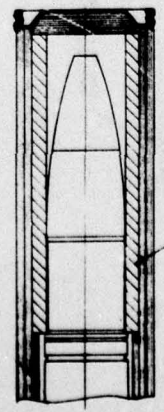

CONCEPT 2D

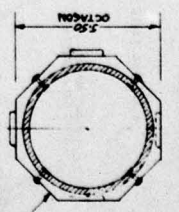
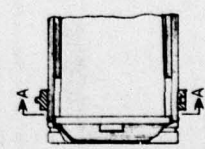

MOLDED POLYSTYRENE END CAPS FOR FIBER BODY BOTH ENDS

DESIGN NO.	DATE	BY	CHKD.	APPROVED	DESCRIPTION	REVISION
10001	1/1/71	J. W. H.	J. W. H.	J. W. H.	CONCEPT #2 FIBER CONTAINER	1
PROJECT: NAVAL AIR FORCE CONTRACT NO. 33(001)71-10001 CONTRACTOR: GENERAL ELECTRIC COMPANY WASHINGTON, D.C. 20540						DRAWING NO. 10001 SHEET NO. 1 TOTAL SHEETS 1
TITLE: TREATED FIBER TUBES & SPACERS RIGID POLYSTYRENE						DRAWING NO. 10001 SHEET NO. 1 TOTAL SHEETS 1
SPECIFICATION: CONCEPT #2 FIBER CONTAINER 76 MM GRCAL CARTRIDGE						DRAWING NO. 10001 SHEET NO. 1 TOTAL SHEETS 1

C-71

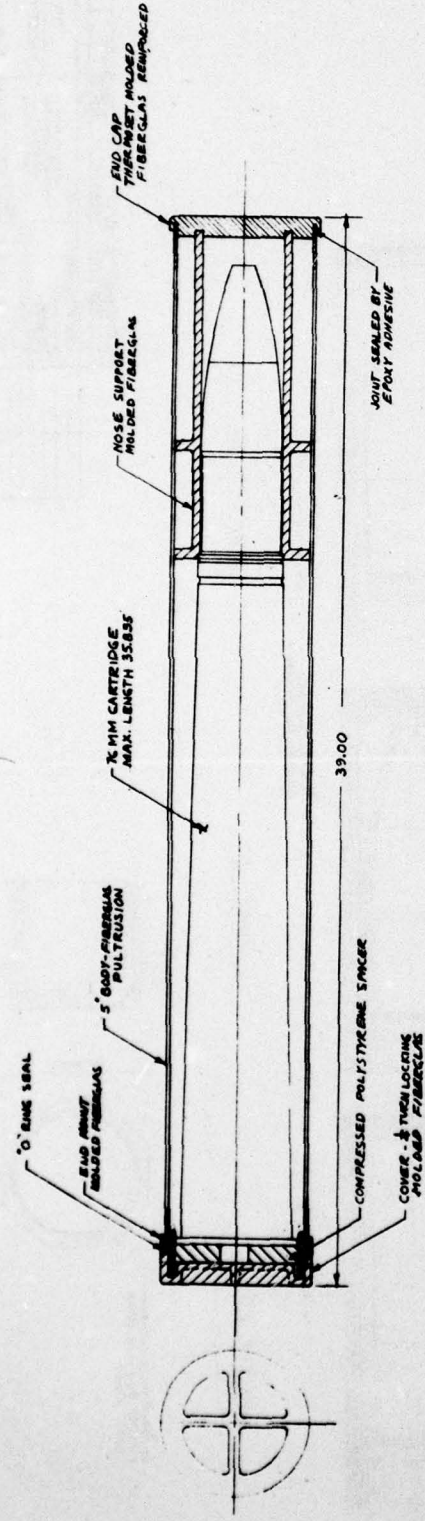

CONCEPT #3A

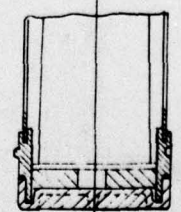

CONCEPT #3B

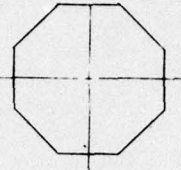
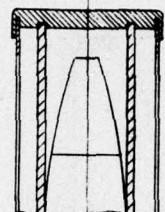

DATE OF SUBMISSION	NO. OF SUBMISSIONS	NO. OF REVISIONS	NO. OF COPIES
10-15-72	1	0	1
PROJECT NO.	PROJECT NAME	PROJECT LOCATION	PROJECT STATUS
CONCEPT #3	FIBERGLAS CONTAINER	76MM G2CAL CARTRIDGE	D 10001 NWHL-7192
DESIGNED BY	DESIGNED DATE	DESIGNED BY	DESIGNED BY
W. J. ...	10-15-72	W. J. ...	W. J. ...
CHECKED BY	CHECKED DATE	CHECKED BY	CHECKED BY
...

C-72

DESIGNED	DATE	APPROVED

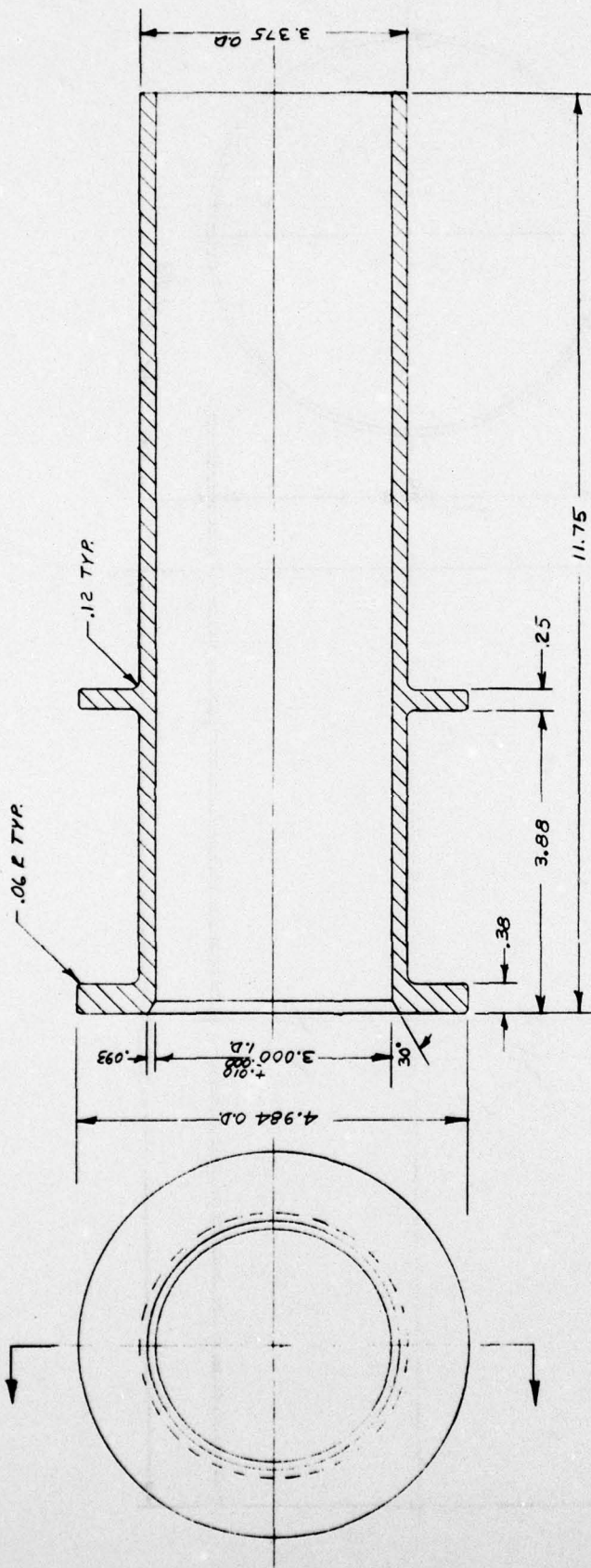

DEPARTMENT OF THE NAVY NAVAL OPERATIONS SYSTEMS COMMAND WASHINGTON, D.C. 20380		NOSE SUPPORT-FIBER GLASS CONTAINER 76 MM		SIZE CODE NO. DRAWING NO. C 10001 NWHL 7352		SCALE 1/1 SHEET OF	
CONTRACT NO.		DATE 3-12-76		APPROVED FOR NOSE		DATE	
DRAWING NO.		DATE		APPROVED		DATE	
MATERIAL		FINISH		APPROVED		DATE	
FINISH		APPROVED		DATE		APPLICATION	
APPLICATION		DATE		APPROVED		DATE	

C-73

DATE	APPROVED

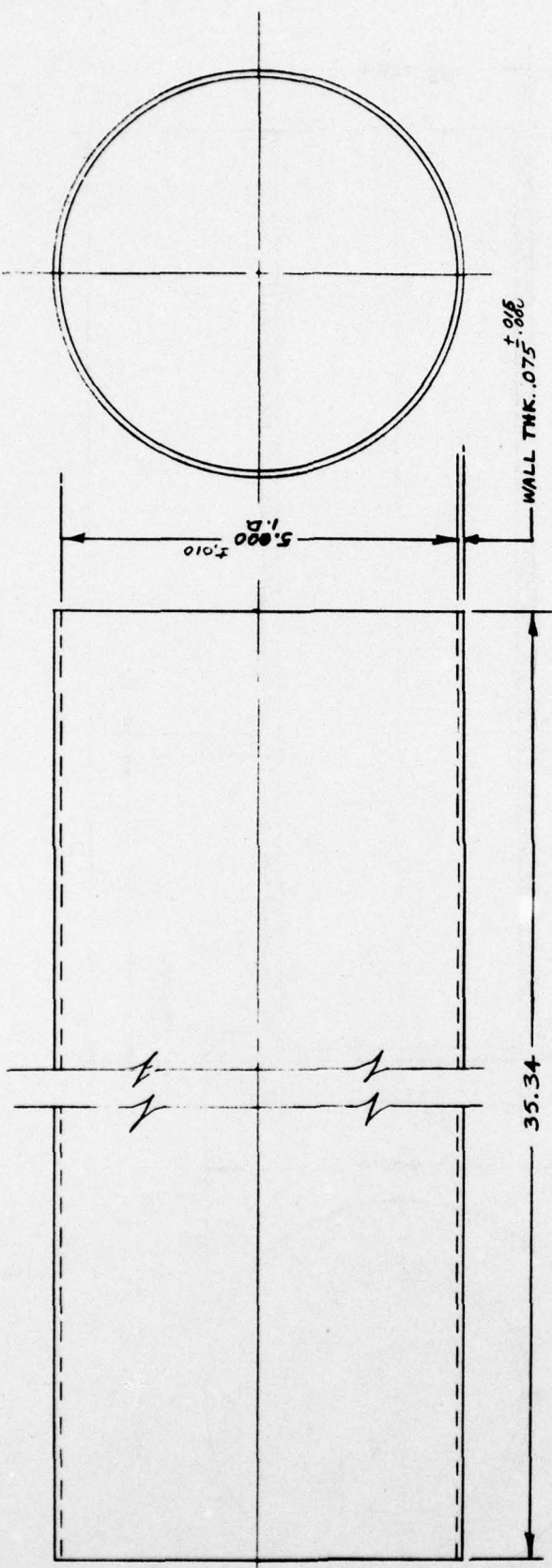

DEPARTMENT OF THE NAVY NAVAL ORDNANCE SYSTEMS COMMAND WASHINGTON, D.C. 20380		FIBER GLASS BODY-CONTAINER 76MM-62 CAL CARTRIDGE	
NAVY WEAPONS HANDLING LABORATORY USMAD BARLE COLTS MFG. CO., N.J. 07722	DATE 3-11-76	SET CODE C 10001	DRAWING NO. NWHL 7351
PREPARED BY DRAWN BY CHECKED BY APPROVED FOR MISC	BY DATE	SCALE 1/1	SHEET OF
TITLE FIBER GLASS REINFORCED PLASTIC CARTRIDGE TUBING - 30,000 PSI TENSILE LONGITUDINAL FIRE RETARDANT ANTI-STATIC		MATERIAL FIBER GLASS PLASTIC TENSILE STRENGTH ± 0.5 DO NOT SCALE THIS DRAWING	
HEAT TREAT	USED ON	APPLICATION	

0-74

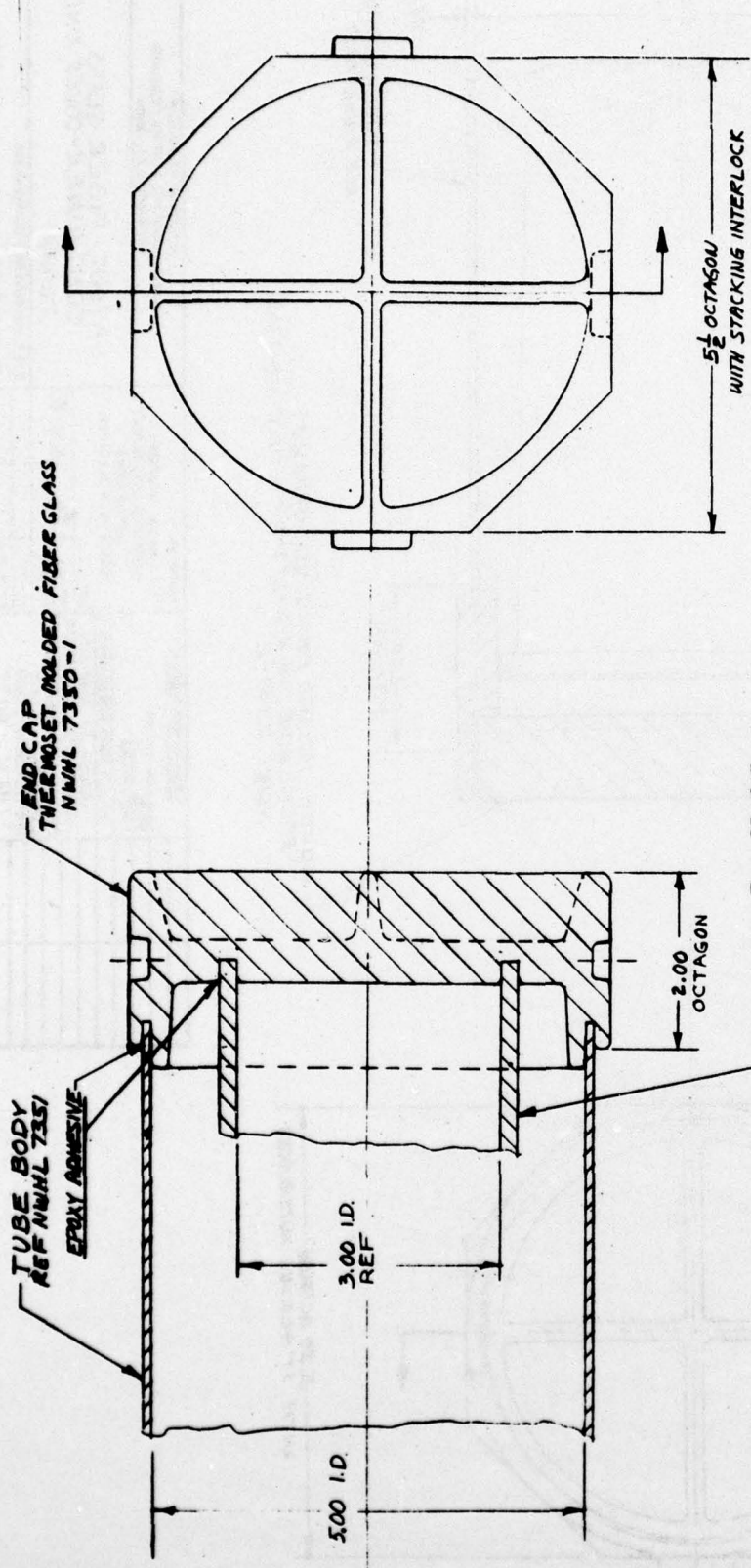

DEPARTMENT OF THE NAVY NAVAL ORDNANCE SYSTEMS COMMAND WASHINGTON, D.C. 20380		LAYOUT - FIBER GLASS CONTAINER, END CAP 76 MM	
DRAWING NO. C 10001		DRAWING NO. 7350	
NAVY WEAPONS HANDLING LABORATORY USMAD EABLE COITS NECK, N.J. 07732		DATE 3-11-76	
APPROVED FOR REVISION BY DATE		SCALE 1/1	
SHEET NO. 1/1		OF 1	

C-75

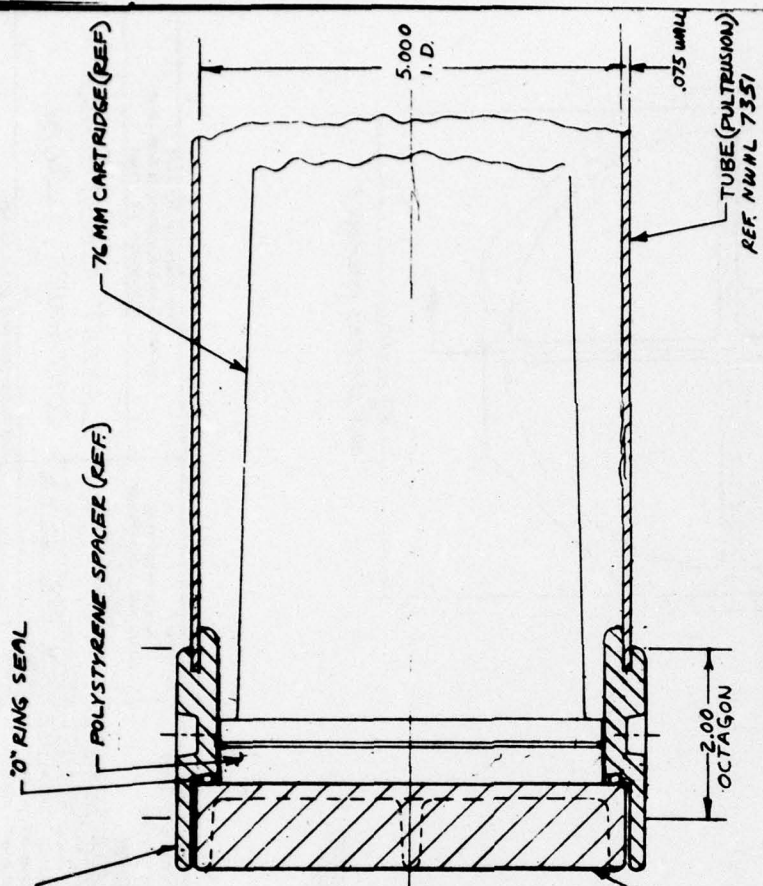

COVER-MOLDED FIBER GLASS (THERMOSET)
5" STUB ACME THD-4 START THD (MULTIPLE STARTING)
NWHL 7349-2

END MOUNT
THERMOSET MOLDED FIBER GLASS
NWHL 7349-1

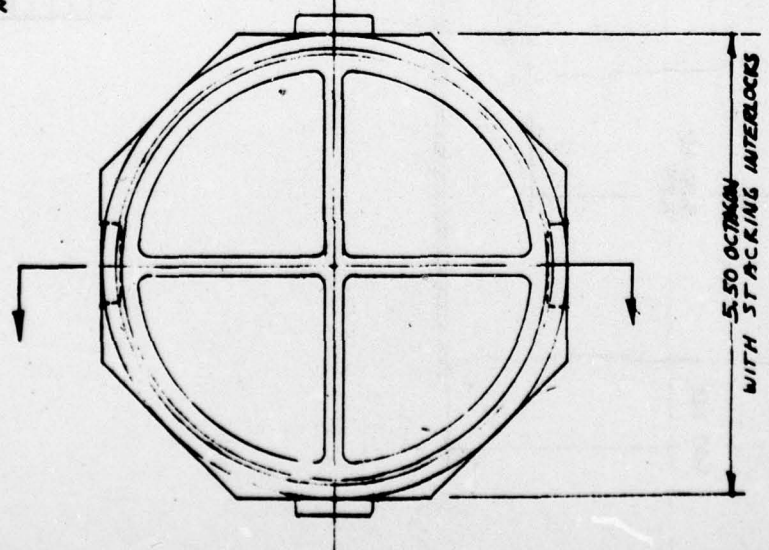

DEPARTMENT OF THE NAVY NAVAL ORDNANCE SYSTEMS COMMAND WASHINGTON, D.C. 20380	
LAYOUT - FIBER GLASS CONTAINER - COVER END 76 MM	
C 10001 NWHL 7349	
DEPARTMENT OF THE NAVY NAVAL WEAPONS HANDLING LABORATORY USNAS BARB COAST WHEEL, N.J. 07722	DATE: 1-10-58 DRAWN BY: [blank] CHECKED BY: [blank] APPROVED FOR ISSUE: [blank]
DRAWING TITLE: [blank] DRAWING NUMBER: [blank] DRAWING SCALE: [blank]	REFERENCE: [blank] MATERIALS: [blank] FINISHES: [blank] DIMENSIONS: [blank]
100 PERCENT TEST SPECIFICATIONS NWHL 7349-1 & 2 FIBER GLASS REINFORCED POLYESTER THERMOSET CONFORMS - FIRE RETARDANT, ANTI- STATIC, -60°F	TEST DATA: [blank] ANALYSIS: [blank]

C 76