

AD-A054 126

DAVID W TAYLOR NAVAL SHIP RESEARCH AND DEVELOPMENT CE--ETC F/G 12/1  
SPECIFICATIONS FOR A SOLID FINITE ELEMENT DATA GENERATOR.(U)  
MAR 78 R J KAZDEN

UNCLASSIFIED

CMLD-78-04

NL

| OF |  
ADA  
064126



END  
DATE  
FILMED  
6-78  
DDC

FOR FURTHER TRAN

**DAVID W. TAYLOR NAVAL SHIP  
RESEARCH AND DEVELOPMENT CENTER**

Bethesda, Md. 20884



12

AD A 054126

SPECIFICATIONS FOR A SOLID FINITE  
ELEMENT DATA GENERATOR

Richard J. Kazden



APPROVED FOR PUBLIC RELEASE: DISTRIBUTION UNLIMITED.

COMPUTATION, MATHEMATICS, AND LOGISTICS DEPARTMENT  
DEPARTMENTAL REPORT

MARCH 1978

CMLD-78-04

DDG FILE COPY

### MAJOR DTNSRDC ORGANIZATIONAL COMPONENTS

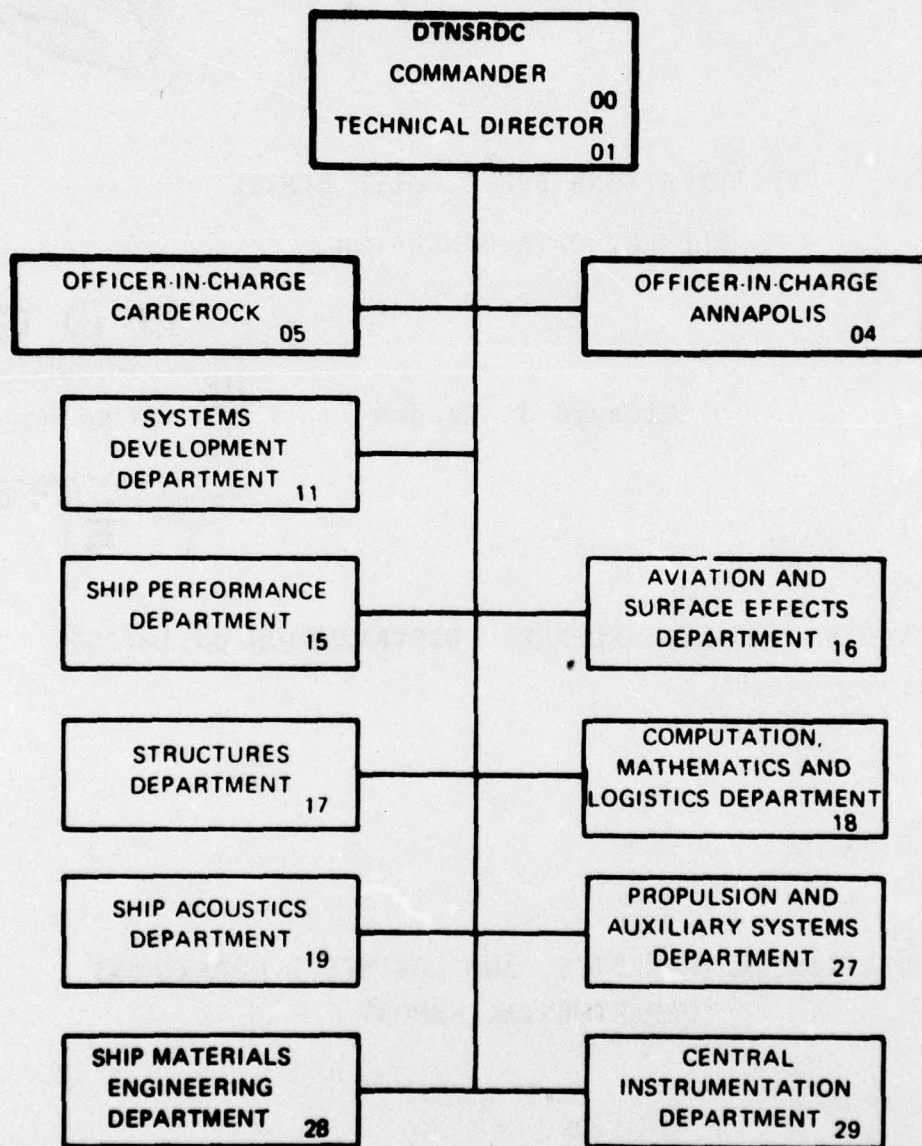

UNCLASSIFIED

SECURITY CLASSIFICATION OF THIS PAGE (When Data Entered)

REPORT DOCUMENTATION PAGE		READ INSTRUCTIONS BEFORE COMPLETING FORM
1. REPORT NUMBER <b>(14)</b> CMLD-78-04	2. GOVT ACCESSION NO.	3. RECIPIENT'S CATALOG NUMBER <b>(1)</b> Research and development rept.
4. TITLE (and Subtitle) <b>(6)</b> SPECIFICATIONS FOR A SOLID FINITE ELEMENT DATA GENERATOR	5. TYPE OF REPORT & PERIOD COVERED R&D	
7. AUTHOR(s) <b>(10)</b> Richard J. Kazden	6. PERFORMING ORG. REPORT NUMBER	
9. PERFORMING ORGANIZATION NAME AND ADDRESS David W. Taylor Naval Ship Research and Development Center Bethesda, Maryland 20084	8. CONTRACT OR GRANT NUMBER(s)	
11. CONTROLLING OFFICE NAME AND ADDRESS	10. PROGRAM ELEMENT, PROJECT, TASK AREA & WORK UNIT NUMBERS Task Area: 53532020 Work Unit: 1-1808-009	12. REPORT DATE <b>(11)</b> Mar 1978
14. MONITORING AGENCY NAME & ADDRESS (if different from Controlling Office) <b>(12)</b> 29p.	13. NUMBER OF PAGES 28	15. SECURITY CLASS. (of this report) UNCLASSIFIED
16. DISTRIBUTION STATEMENT (of this Report)  APPROVED FOR PUBLIC RELEASE: DISTRIBUTION UNLIMITED.		15a. DECLASSIFICATION/DOWNGRADING SCHEDULE
17. DISTRIBUTION STATEMENT (of the abstract entered in Block 20, if different from Report)		
18. SUPPLEMENTARY NOTES		
19. KEY WORDS (Continue on reverse side if necessary and identify by block number) Data Generator Finite Element Method Structural Model Three-dimensional Solid Finite Elements		
20. ABSTRACT (Continue on reverse side if necessary and identify by block number) Specifications are given for the implementation of a solid finite element data generation capability that uses geometric information obtained from a geometry processing program called G-PRIME. A proposed user definition format is described; the characteristics of finite element models that could be generated with this capability are discussed, and two sample problems are presented to illustrate the proposed technique.		

DD FORM 1473  
1 JAN 73

EDITION OF 1 NOV 65 IS OBSOLETE  
S/N 0102-014-6601

UNCLASSIFIED

SECURITY CLASSIFICATION OF THIS PAGE (When Data Entered)

406847

YB

## PREFACE

This report contains the specifications for a new data generation capability for three-dimensional solid finite elements which will be implemented in the near future. This capability is expected to be included in the STAGING finite element analysis package being developed jointly by the Navy and the Air Force. In order to provide a capability that will be useful to as wide a community as possible, we are now soliciting comments and suggestions from all interested parties.

ACCESSION for	
NTIS	White Section <input checked="" type="checkbox"/>
DDC	Buff Section <input type="checkbox"/>
UNANNOUNCED	<input type="checkbox"/>
JUSTIFICATION.....	
BY.....	
DISTRIBUTION/AVAILABILITY CODES	
Dist.	AVAIL. and/or SPECIAL
A	

## TABLE OF CONTENTS

	Page
LIST OF FIGURES.....	v
TABLE.....	v
ABSTRACT.....	1
INTRODUCTION.....	1
DEFINING THE STRUCTURAL MODEL.....	2
DEFINITIONS OF KEY REFERENCE SURFACES AND ZONES.....	3
REQUIRED PROPERTIES FOR KEY REFERENCE SURFACES.....	3
USER SPECIFICATION OF KEY REFERENCE SURFACES AND ZONES.....	6
SOME GUIDELINES FOR CHOOSING KEY REFERENCE SURFACES.....	7
THE GENERATED FINITE ELEMENT MODEL.....	8
THE ROLE OF REFERENCE SURFACES.....	8
GENERATED ELEMENTS AND GENERATED GRID POINTS.....	8
CONSIDERATIONS FOR THE IMPLEMENTATION.....	10
CONCLUSION.....	11
APPENDIX - SAMPLE PROBLEMS.....	12

## LIST OF FIGURES

	Page
1 - Example A of Zones and Key Reference Surfaces.....	4
2 - Example B of Zones and Key Reference Surfaces.....	5
3 - Example of Brick Element.....	9
4 - Two Orthographic Views of Globe Valve, Sample Problem 1.....	13
5 - Isometric View of 1/8 of Globe Valve, Sample Problem 1.....	14
6 - Graphical Method for Specifying Occupied Zones, Sample Problem 1.....	16
7 - Two Orthographic Views of Object for Sample Problem 2.....	19
8 - Graphical Method for Specifying Occupied Zones, Sample Problem 2.....	22

---

Table 1 - Surfaces Used for Describing Key Reference Surfaces, Sample Problem 2.....	20
---	----

## ABSTRACT

Specifications are given for the implementation of a solid finite element data generation capability that uses geometric information obtained from a geometry processing program called G-PRIME. A proposed user definition format is described; the characteristics of finite element models that could be generated with this capability are discussed, and two sample problems are presented to illustrate the proposed technique.

## INTRODUCTION

It is the intent of this effort to construct a set of programs for generating finite element models of three-dimensional solid structures, e.g., those manufactured by processes such as casting, forging, and turning. We plan to accomplish this by interfacing two existing pieces of computer software: SOLIDGEN and G-PRIME.

SOLIDGEN is a data generation program for generating three-dimensional solid finite element models. The SOLIDGEN approach is to map a structure onto a three-dimensional array of cells known as "zones," with each zone subdivided into brick-shaped finite elements. The G-PRIME package<sup>1\*</sup> has facilities for defining a wide variety of surfaces through its own geometric language. We plan to integrate these two capabilities by using G-PRIME surfaces as the faces of the zones used by SOLIDGEN. The surfaces defined by the G-PRIME geometric language will be identified by symbolic names. The proposed data generator, an updated and augmented version of SOLIDGEN, will assume that those surfaces reside in a G-PRIME data base and can be retrieved from the data base by referencing the symbolic names.

---

\* A complete listing of references is given on page 11.

The user of this proposed capability will specify which zones in the three-dimensional array are to be used for the model, the type of elements to be generated, and the names of G-PRIME surfaces to be associated with the faces of the zones. From this information the program will generate a finite element model which includes all the element and grid point definitions necessary for finite element analysis.

The scope of the application of the data generator described in this report is quite broad. With imagination on the part of the user, a wide variety of solid structural shapes can be handled. While simple shapes usually suggest one rather obvious modeling, the more complex shapes tend to be amenable to a number of different modelings. In general, the advantages of automatic generation over manual generation will increase with the complexity of the structural shape. However, there are cases when automatic generation coupled with a small amount of manual generation will greatly simplify the modeling of a complex problem.

The concepts described in this report are intended to serve as specifications for future work. We would, therefore, welcome suggestions from potential users of this data generator.

#### DEFINING THE STRUCTURAL MODEL

A method for defining structural models is described below. The basic building block for the model is the "zone," a volume which is bounded by six faces. To create a model the user must visualize a subdivision of his structure into zones in a manner similar to that used to manually create a finite element model. Since G-PRIME surfaces are used to describe the zone faces, the shape of each zone can be very general. The zones are related to one another by the network of "key

reference surfaces," which are formed from the zone faces. When the user has obtained a satisfactory subdivision of his structure into zones, the key reference surfaces can be identified by following a straightforward procedure.

#### DEFINITIONS OF KEY REFERENCE SURFACES AND ZONES

Consider a network of intersecting surfaces which form cells, each of which is bounded by six surfaces. The surfaces are called "key reference surfaces"; the cells are called "zones". The key reference surfaces are grouped into three families: key  $\alpha$ -reference surfaces, key  $\beta$ -reference surfaces, and key  $\gamma$ -reference surfaces. Two key reference surfaces in the same family are said to be "adjacent" if, within the bounds of the structural model being defined, no key reference surfaces from the same family intervene (i.e., a path exists from any point on one of the surfaces to any point on the other surface without crossing a third key reference surface in the same family). In each zone two opposing faces belong to the key  $\alpha$ -reference surface family and are adjacent, two more opposing faces belong to the key  $\beta$ -reference surface family and are adjacent, and the remaining opposing faces belong to the key  $\gamma$ -reference surface family and are adjacent.

In each family the key reference surfaces are numbered with consecutive integers, starting with 1; adjacent key reference surfaces are labeled consecutively.

The zones (considered collectively) form the structural model and, when subdivided by the data generator into finite elements, yield the desired modeling.

Some examples of key reference surfaces and zones for structural models are shown in Figures 1 and 2.

#### REQUIRED PROPERTIES FOR KEY REFERENCE SURFACES

The following two requirements, which must be met within the bounds of the desired structural model, assure that the structural model does not present unresolvable ambiguities to

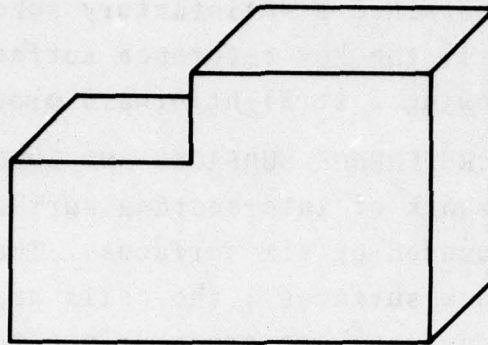

Figure 1a - Object to be Modeled

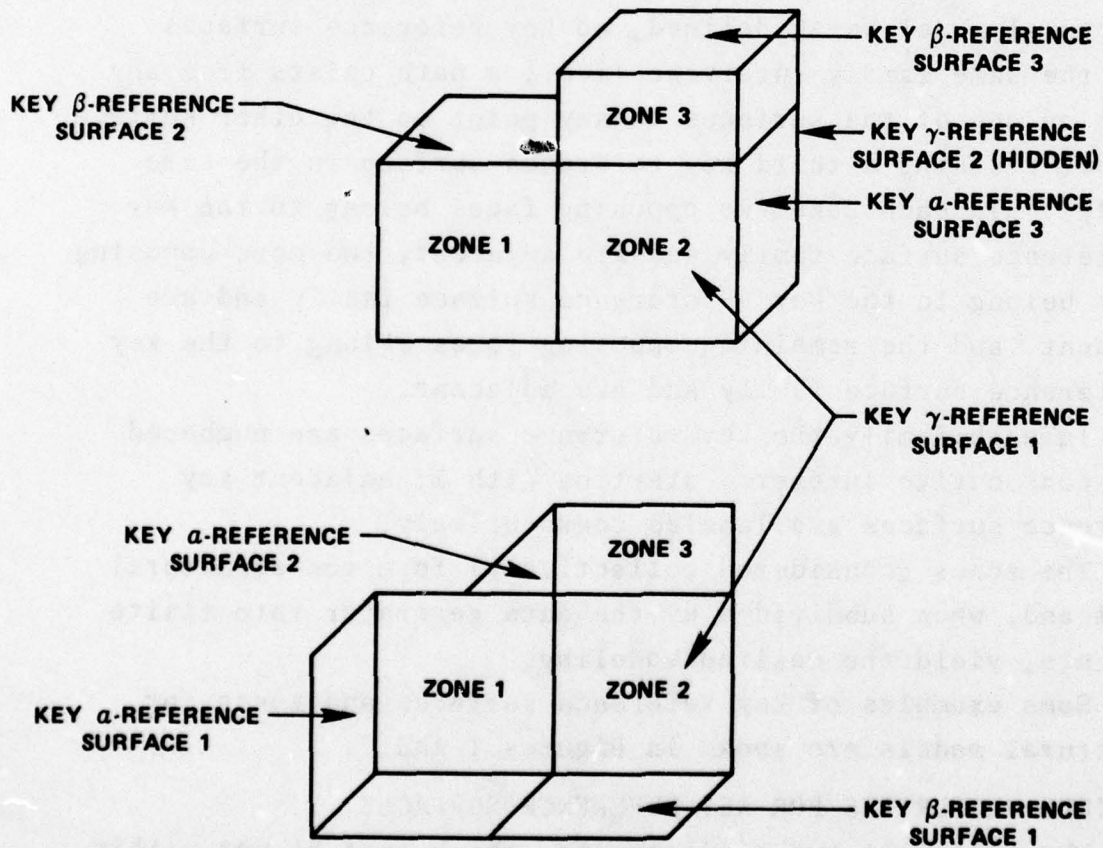

Figure 1b - Object with Zones and Key Reference Surfaces Shown

Figure 1 - Example A of Zones and Key Reference Surfaces

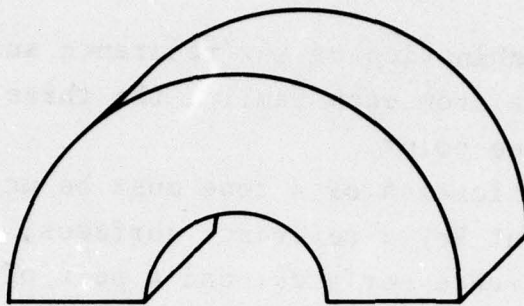

Figure 2a - Object to be Modeled

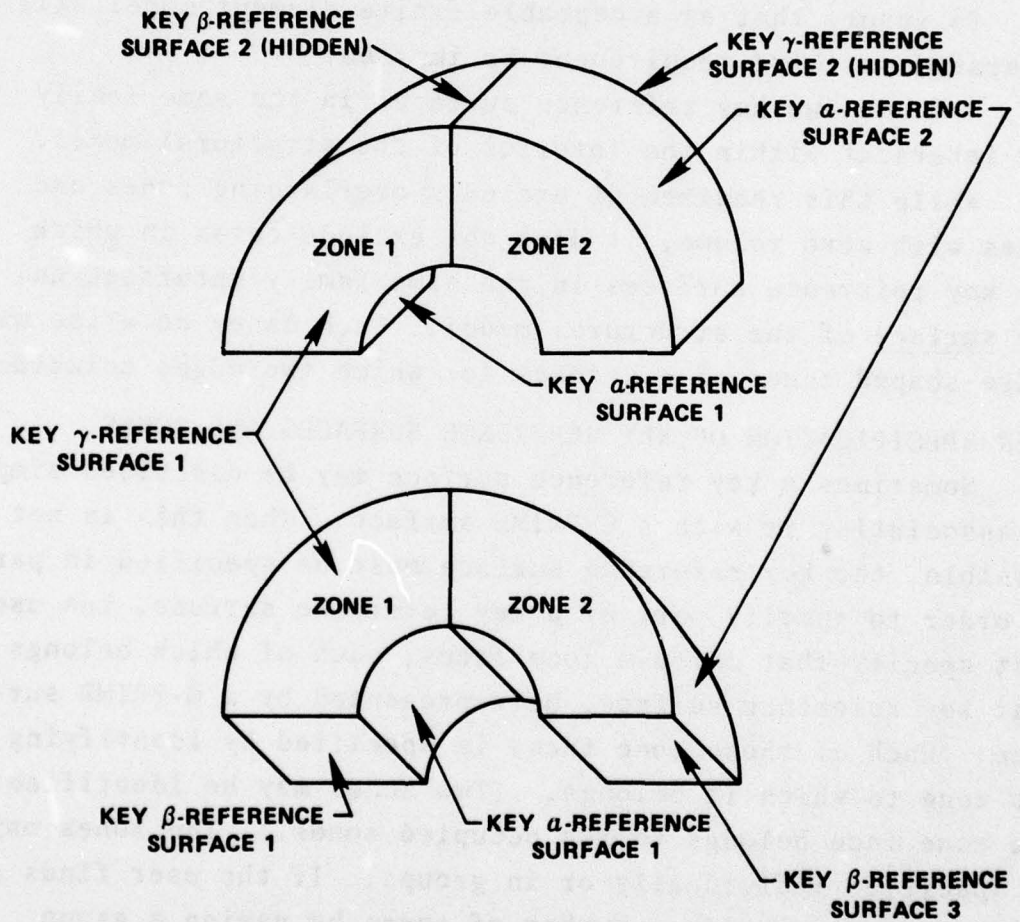

Figure 2b - Object with Zones and Key Reference Surfaces Shown

Figure 2 - Example B of Zones and Key Reference Surfaces

the data generator:

- In any combination of key reference surfaces which contains one surface from each family, the three surfaces must intersect at only one point.

- The specification of a zone must be unique, that is, if a pair of adjacent key  $\alpha$ -reference surfaces, a pair of adjacent key  $\beta$ -reference surfaces, and a pair of adjacent key  $\gamma$ -reference surfaces are given, they must designate only one zone.

To insure that an acceptable finite element model will be generated a third requirement is imposed:

- No two key reference surfaces in the same family may intersect within the interior of the structural model.

While this requirement excludes overlapping zones and zones with zero volume, it does not exclude cases in which two key reference surfaces in the same family intersect on the surface of the structural model. Such cases do arise with wedge-shaped zones, i.e., zones for which two edges coincide.

#### USER SPECIFICATION OF KEY REFERENCE SURFACES AND ZONES

Sometimes a key reference surface may be described simply by associating it with a G-PRIME surface. When this is not possible, the key reference surface must be specified in parts. In order to specify part of a key reference surface, the user must specify that certain zone faces, each of which belongs to that key reference surface, be represented by a G-PRIME surface. Each of these zone faces is specified by identifying the zone to which it belongs. (Two zones may be identified if the zone face belongs to two occupied zones.) The zones may be specified individually or in groups. If the user finds it convenient to specify a number of zones by naming a group which includes some zones which have no faces belonging to the key reference surface, such zones will be automatically ignored.

The user must specify which zones are to be used for the structural model by declaring blocks of zones to either be occupied (used for structural model) or vacant (not used). For reference purposes the user will be required to label the occupied zones with positive integers.

#### SOME GUIDELINES FOR CHOOSING KEY REFERENCE SURFACES

The first step the user must take in the modeling of his structure is to visualize and define three families of key reference surfaces which subdivide his model into zones. Although there is no well-defined procedure for doing this, the user should try to visualize how his structure could be subdivided into volumes (zones), each of which is bounded by six surfaces (zone faces).

Once the user has determined how his model is to be subdivided into zones, he may arbitrarily choose the way in which the surfaces bounding the zones are to constitute the three families of key reference surfaces. He may do this, for example, by looking at one zone and designating pairs of opposing faces to be members of the three respective families of key reference surfaces. The pattern established for that zone would hold for adjacent zones and, hence, for the entire model.

The surfaces used to describe key reference surfaces (or zone faces, which are parts of key reference surfaces) will fall into two categories:

- (1) those which lie on the model's surface, and
- (2) those which (except possibly for zone edges, which are boundaries of zone faces) lie within the interior of the model.

While the first category occurs "naturally" as part of the model's surface, the second category consists of surfaces whose sole purpose is to help subdivide the model into zones. Examples of surfaces in the second category occur in each of the sample problems in the Appendix.

## THE GENERATED FINITE ELEMENT MODEL

The finite element model generated by SOLIDGEN may either be stored in the G-PRIME data base for visual verification and editing or sent directly to a file and analyzed by a finite element structural analysis program.

### THE ROLE OF REFERENCE SURFACES

The generated model contains two kinds of "reference surfaces": key reference surfaces and interior reference surfaces. The key reference surfaces have already been described. The purpose of interior reference surfaces is to subdivide the zones into the desired generated isoparametric brick elements. There is a set of interior reference surfaces for each pair of adjacent key reference surfaces in a family. Both kinds of reference surfaces run through the model (i.e., they cross zone boundaries), assuring the compatibility of the generated isoparametric brick elements at the interfaces of the zones. The key reference surfaces must be specified by the user, but the interior reference surfaces are created by SOLIDGEN. The user is required to specify only the number of interior reference surfaces that lie between each two adjacent key reference surfaces in the same family.

### GENERATED ELEMENTS AND GENERATED GRID POINTS

The subdivision of each zone is accomplished by using a method of Zienkiewicz.<sup>2</sup>

The generated elements produced by subdivision of the zones are brick elements. The user must specify the type of brick elements to be used; that is, he must specify the number of midside nodes to be used along the edges of the generated elements. (An example of a brick element is shown in Figure 3.) This specification consists of three integers that indicate the number of midside nodes for

- (1) the four edges that run between  $\alpha$ -reference surfaces,

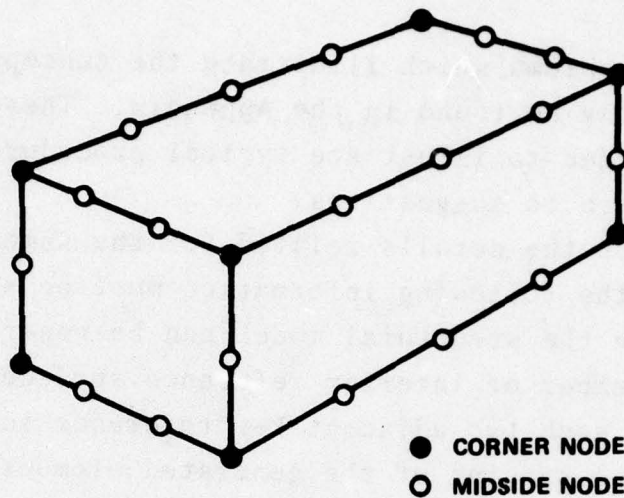

Figure 3 - Example of Brick Element

- (2) the four edges that run between  $\beta$ -reference surfaces, and
- (3) the four edges that run between  $\gamma$ -reference surfaces.

The specification applies to the entire model. Individual elements are identified in terms of their respective bounding reference surfaces.

The coordinates of the generated grid points are determined as part of the process of subdividing the zones. To compensate for differences which might arise between the exterior surfaces of the structural model as defined by the user and the corresponding surfaces as produced by the solid element generator, the coordinates of all the generated exterior grid points will be modified so that the points lie precisely on the user-defined exterior surfaces.

## CONSIDERATIONS FOR THE IMPLEMENTATION

Two sample problems which illustrate the concepts of model definition may be found in the Appendix. These sample problems are intended to illustrate typical procedures; we are, therefore, open to suggestions.

In addition to the details related for the sample problems in the Appendix, the following information must be specified by the user before the structural model can be generated:

(1) the number of interior reference surfaces to be generated between each two adjacent key reference surfaces (which controls the spacing of the generated elements); and

(2) the type of element to be generated, which is given by specifying the number of midside nodes in each direction on the generated brick elements.

In addition, other information of a non-geometric nature (e.g., material properties) may be required by the finite element structural analysis program being used to analyze the generated model.

Although not essential to the generation of data, the following features should prove to be helpful:

(1) Graphical display of various entities in various modes, as follows:

<u>Entities</u>	<u>Modes</u>
key reference surfaces	true shape
interior reference surfaces	topological model
grid points	one zone at a time
zone defining points	cross-sections taken at key
generated brick elements	reference surfaces - two
zones, occupied and vacant	possible directions
	display only visible parts
	(hidden-line removal)

(2) A "restart" capability, that is, a capability for permitting the user to rerun his problem with small changes without having to repeat the specification of the entire problem.

#### CONCLUSION

The solid element data generation capability specified in this report should yield the usual advantages of automatic data generation: elimination of tedious and repetitious labor and elimination of human error. The power of the SOLIDGEN data generator will be combined with the versatility of the G-PRIME surface definition capability.

#### REFERENCES

1. McKee, J.M. and R.J. Kazden, "G-PRIME B-Spline Manipulation Package Basic Mathematical Subroutines," Computation, Mathematics, and Logistics Department Research and Development Report 77-0036 (Apr 1977).
2. Zienkiewicz, O.C., "Isoparametric and Allied Numerically Integrated Elements - A Review," Numerical and Computer Methods in Structural Mechanics, edited by S.J. Fenves, A.R. Robinson, N. Perrone, and W.C. Schnobrich, Academic Press (1973), pp. 13-41.

## APPENDIX - SAMPLE PROBLEMS

The two sample problems included here illustrate a proposed method for specifying a problem to the data generator. Each problem is presented by means of a "script" which might occur at a conversational terminal. At various points in the script, suggestions are offered for the use of interactive graphical aids to the specification of these sample problems.

### SAMPLE PROBLEM 1

Figure 4 shows two orthographic views of a globe valve, of which only the housing (stationary part) is to be modeled. Since there are three planes of symmetry (see Figure 4), one-eighth of the valve is sufficient for the structural modeling and analysis. Before he can describe the modeling of his object in terms of key reference surfaces and zones, the user must visualize his object as being subdivided into zones which are bounded by a consistently defined set of key reference surfaces. This process does not lend itself to any algorithm (specific procedure) and will usually require considerable thought. The following details of this sample problem are based on the assumption that the user has gone through that process. Figure 5 shows how one-eighth of the valve would appear and also shows some surfaces which will be used for the structural modeling. For example, S2 is a spherical surface used to describe most of the interior of the globe valve housing. Note that S14, a plane which passes through the intersection of S10 and S11, helps subdivide the model into zones and was created solely for that purpose. Having visualized his model, the user must first define it topologically; that is, he must

- (1) specify the number of key reference surfaces in each of the three directions;
- (2) specify which zones in the network of key

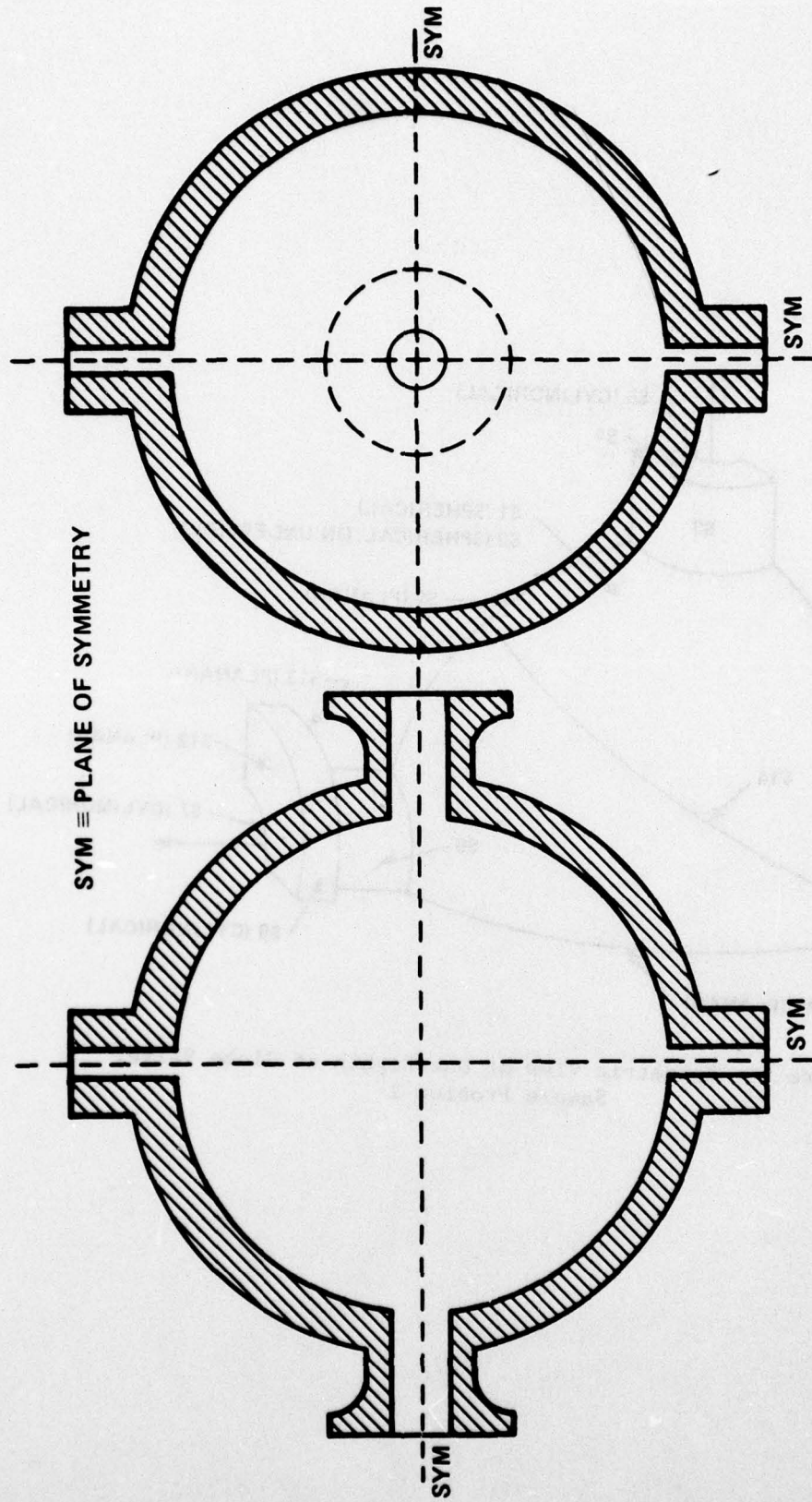

Figure 4 - Two Orthographic Views of Globe Valve, Sample Problem 1

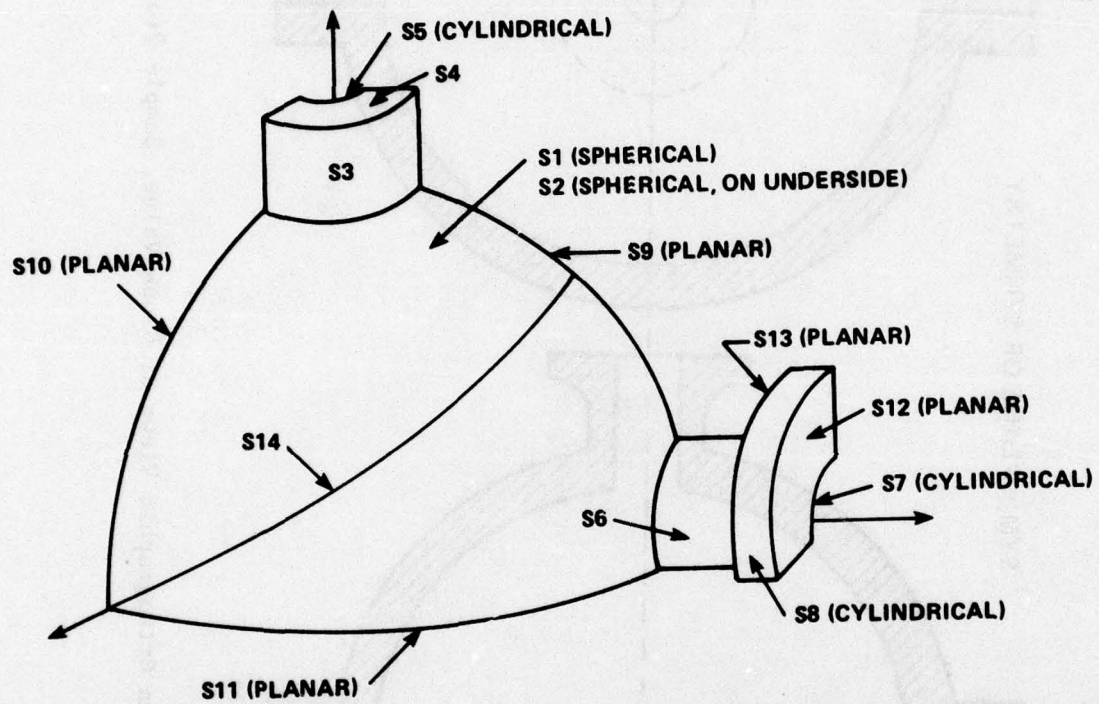

Figure 5 - Isometric View of One-Eighth of Globe Valve,  
Sample Problem 1

reference surfaces are occupied (used for the structural model); and

(3) label (assign a number to) each occupied zone. This process could be performed at an interactive terminal. The following dialogue is an example of how this might take place:

Computer Prompt: Specify number of key  $\alpha$ -reference surfaces, number of key  $\beta$ -reference surfaces, and number of key  $\gamma$ -reference surfaces.

User Entry: 4, 5, 2

Computer Prompt: How many zones are occupied?

User Entry: 8

Computer Prompt: Give the locations of the 8 occupied zones by specifying the lower-numbered bounding key reference surface in each direction.

User Entry: Z1,3,1,1  
Z2,2,1,1  
Z3,1,1,1  
Z4,1,2,1  
Z5,1,3,1  
Z6,1,4,1  
Z7,2,4,1  
Z8,3,2,1

Specifying which zones are occupied and labeling the zones may also be done graphically, as shown in Figure 6. Note that in Figure 6, which shows only the topological properties of the structural model, the key reference surfaces are shown schematically. A drawing of the type shown in Figure 6 can also help the user to visualize his problem. For models with more than one layer of zones in the  $\gamma$ -direction, a similar procedure may be used for each layer of zones that lies between two adjacent key  $\gamma$ -reference surfaces.

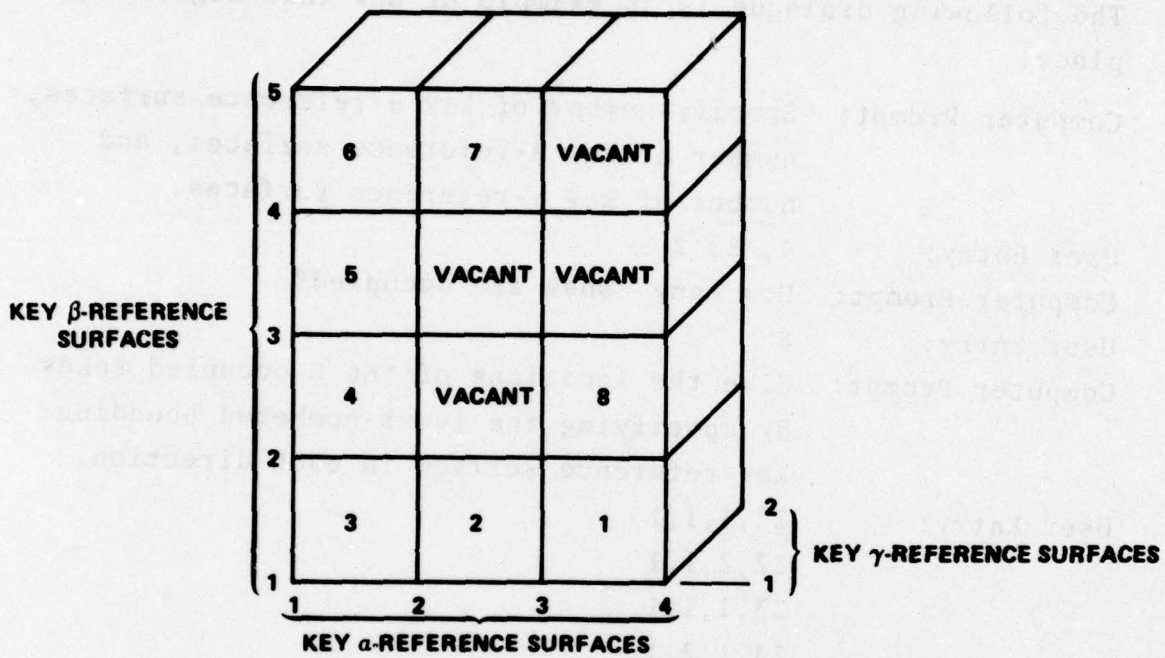

Figure 6 - Graphical Method for Specifying Occupied Zones, Sample Problem 1

Once the topological model has been specified, the user must describe the key reference surfaces.

Computer Prompt: Please describe the key reference surfaces. Start with the key  $\alpha$ -reference surfaces. Please specify the surface number, the G-PRIME surface, and the zones for which this surface definition is to hold.

User Entry: 1,S2,ALL  
2,S1,ALL  
3,S13,1,8,2  
3,S4,7  
4,S12,ALL  
DONE

Computer Prompt: Please go on to the key  $\beta$ -reference surfaces.

User Entry: 1,S7,ALL  
2,S6,ALL  
3,S8,8  
3,S14,4,5  
4,S3,ALL  
5,S5,ALL  
DONE

Computer Prompt: Please go on to the key  $\gamma$ -reference surfaces.

User Entry: 1,S11,8,1,2,3,4  
1,S10,5,6,7  
2,S9,ALL  
DONE

## SAMPLE PROBLEM 2

Figure 7 shows two orthographic views of a machine part. Since there are two planes of symmetry (see Figure 7), one-fourth of the part is sufficient for the structural modeling and analysis. Figure 7 also shows some surfaces which will be used for the structural modeling, i.e., for defining the key reference surfaces; these surfaces are described in Table 1. Note that the sole purpose of S11 (See Table 1) is to help subdivide the model into zones.

The user must first define his structural model topologically:

- (1) specify the number of key reference surfaces in each of the three directions;
- (2) specify which zones in the network of key reference surfaces are occupied (used for the structural model); and
- (3) label (assign a number to) each occupied zone.

Computer Prompt: Specify number of key  $\alpha$ -reference surfaces, number of key  $\beta$ -reference surfaces, and number of key  $\gamma$ -reference surfaces

User Entry: 4, 4, 3

Computer Prompt: How many zones are occupied?

User Entry: 13

Computer Prompt: Give the locations of the 13 occupied zones by specifying the lower-numbered bounding key reference surface in each direction.

User Entry:           Z1,1,1,1                   Z9,2,2,2  
                  Z2,2,1,1                   Z10,3,2,2  
                  Z3,3,1,1                   Z11,1,3,2  
                  Z4,3,2,1                   Z12,2,3,2  
                  Z5,1,1,2                   Z13,3,3,2  
                  Z6,2,1,2  
                  Z7,3,1,2  
                  Z8,1,2,2

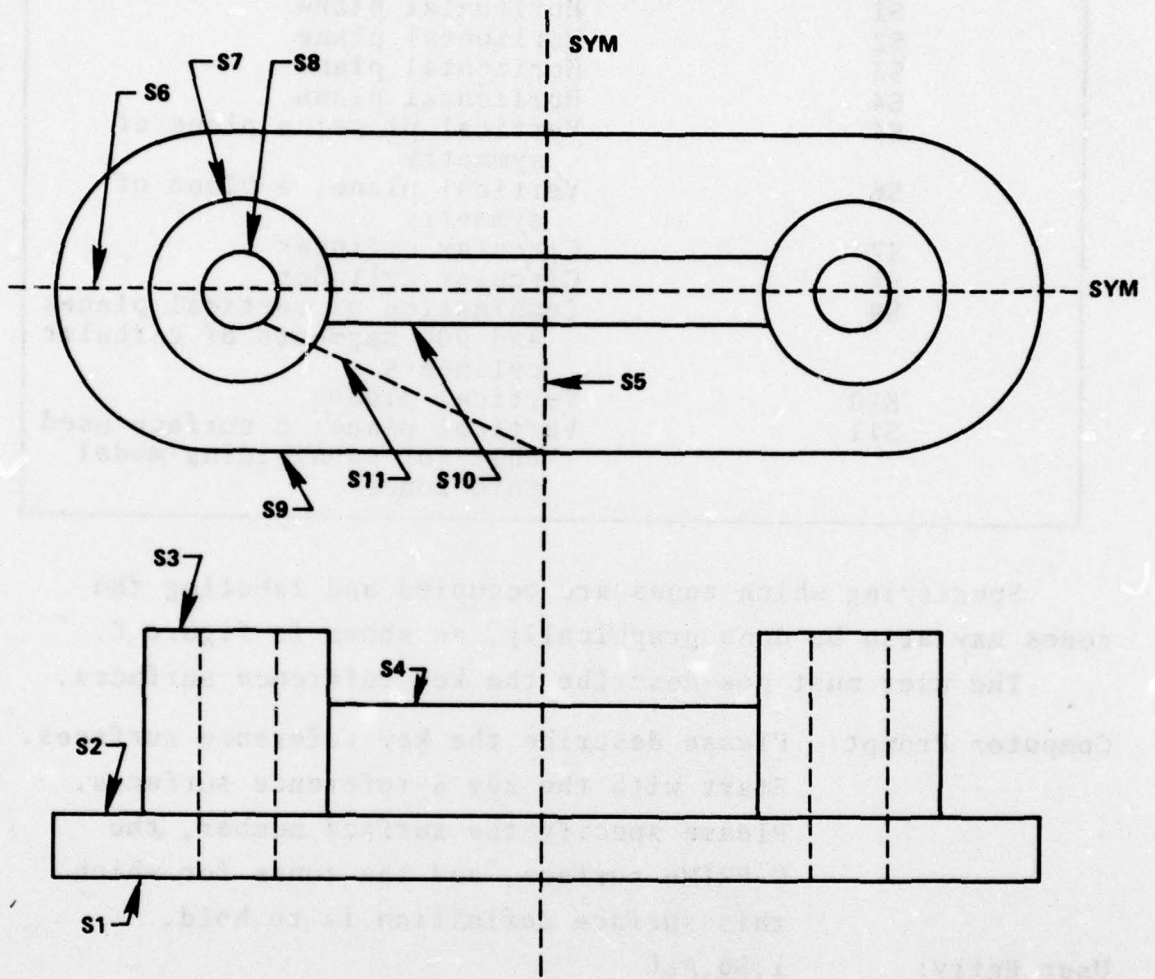

Figure 7 - Two Orthographic Views of Object for Sample Problem 2

TABLE 1 - SURFACES USED FOR DESCRIBING KEY REFERENCE SURFACES, SAMPLE PROBLEM 2

Surface	Description
S1	Horizontal plane
S2	Horizontal plane
S3	Horizontal plane
S4	Horizontal plane
S5	Vertical plane; a plane of symmetry
S6	Vertical plane; a plane of symmetry
S7	Circular cylinder
S8	Circular cylinder
S9	Combination of vertical planes and 90° segments of circular cylinders
S10	Vertical plane
S11	Vertical plane; a surface used only for subdividing model into zones

Specifying which zones are occupied and labeling the zones may also be done graphically, as shown in Figure 8.

The user must now describe the key reference surfaces.

Computer Prompt: Please describe the key reference surfaces. Start with the key  $\alpha$ -reference surfaces. Please specify the surface number, the G-PRIME surface, and the zones for which this surface definition is to hold.

User Entry: 1,S6,ALL  
2,S11,ALL  
3,S10,ALL  
4,S6,ALL  
DONE

Computer Prompt: Please go on to the key  $\beta$ -reference surfaces.

User Entry: 1,S1,ALL  
2,S2,ALL  
3,S4,ALL  
4,S3,ALL  
DONE

Computer Prompt: Please go on to the key  $\gamma$ -reference surfaces.

User Entry: 1,S9,1  
1,S5,ALL EXCEPT 1  
2,S7,ALL  
3,S8,ALL  
DONE

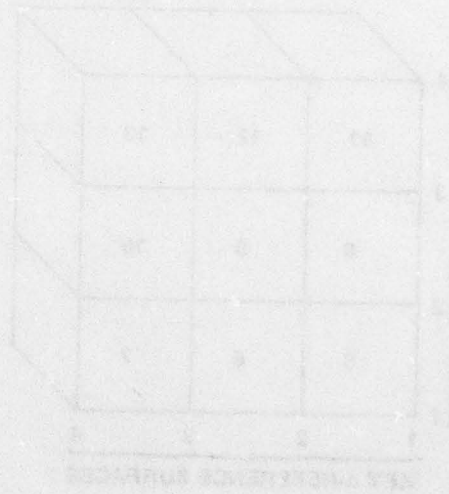

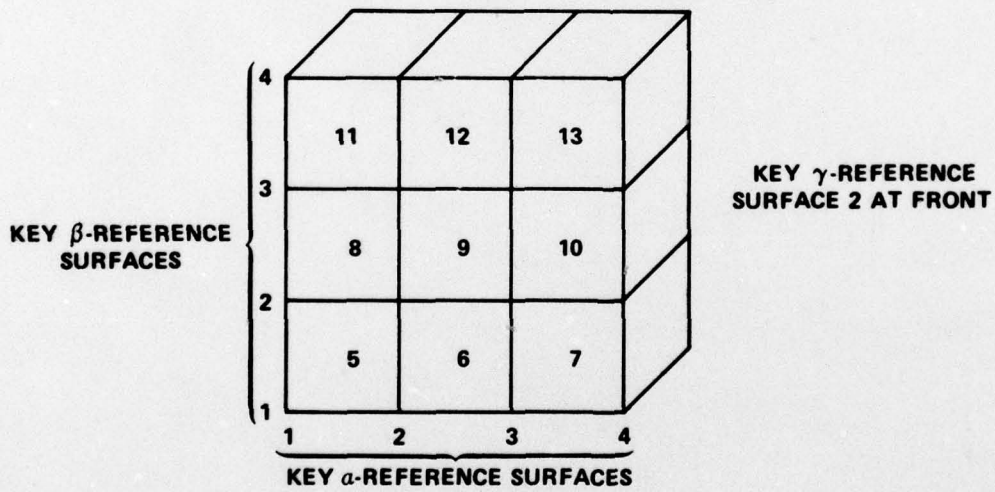
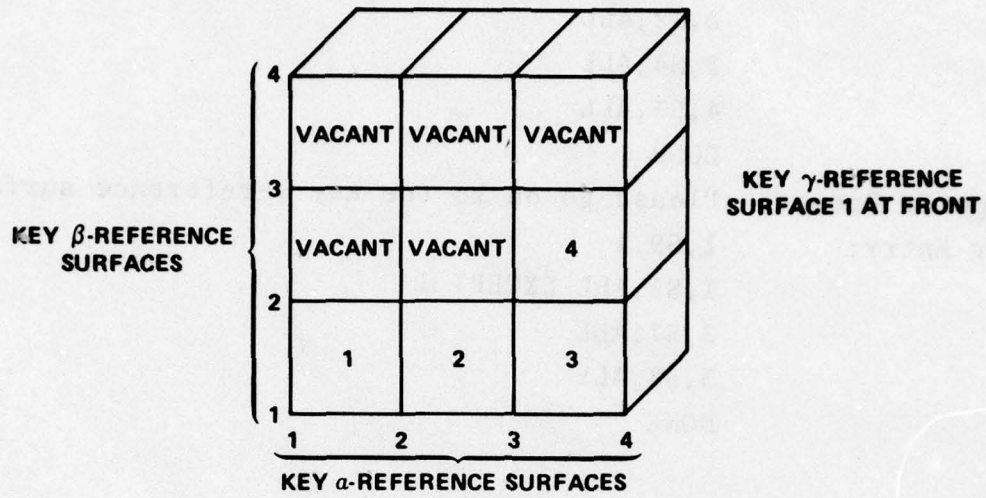

Figure 8 - Graphical Method for Specifying Occupied Zones, Sample Problem 2

DISTRIBUTION LIST

Copies:

1 NSWC White Oak  
1 R.J. Edwards

1 NUSC New London  
1 A. Carlson

3 NAVSEC  
1 R. Keltie  
1 J. Claffee  
1 J. Snyder

12 DDC

4 AFFDL  
1 B. Groomes  
1 P. Pourier  
1 J. Johnson  
1 J. Folck

1 BATTELLE COLUMBUS LABS  
505 King Avenue  
Columbus, Ohio 43201  
ATTN: Gene Hulbert

DTNSRDC DIST:

1 1720.2 Hom, K.  
1 1720.3 Roth, P.  
1 1720.6 Rockwell, R.D.  
1 1730.5 Meyer, P.  
1 1800 Gleissner, G.  
1 1805 Cuthill, E.H.  
2 1809.3 Harris, D.  
1 1840 Lugt, H.J.  
1 1843 Schot, J.W.  
1 1844 Dhir, S.K.  
10 1844 Kazden, R.  
20 1844 McKee, J.M.  
1 2723 Coblenz, R.  
1 522 Library

**DTNSRDC ISSUES THREE TYPES OF REPORTS**

**1. DTNSRDC REPORTS, A FORMAL SERIES, CONTAIN INFORMATION OF PERMANENT TECHNICAL VALUE. THEY CARRY A CONSECUTIVE NUMERICAL IDENTIFICATION REGARDLESS OF THEIR CLASSIFICATION OR THE ORIGINATING DEPARTMENT.**

**2. DEPARTMENTAL REPORTS, A SEMIFORMAL SERIES, CONTAIN INFORMATION OF A PRELIMINARY, TEMPORARY, OR PROPRIETARY NATURE OR OF LIMITED INTEREST OR SIGNIFICANCE. THEY CARRY A DEPARTMENTAL ALPHANUMERICAL IDENTIFICATION.**

**3. TECHNICAL MEMORANDA, AN INFORMAL SERIES, CONTAIN TECHNICAL DOCUMENTATION OF LIMITED USE AND INTEREST. THEY ARE PRIMARILY WORKING PAPERS INTENDED FOR INTERNAL USE. THEY CARRY AN IDENTIFYING NUMBER WHICH INDICATES THEIR TYPE AND THE NUMERICAL CODE OF THE ORIGINATING DEPARTMENT. ANY DISTRIBUTION OUTSIDE DTNSRDC MUST BE APPROVED BY THE HEAD OF THE ORIGINATING DEPARTMENT ON A CASE-BY-CASE BASIS.**