

AD-A054 416

AIR FORCE AERO PROPULSION LAB WRIGHT-PATTERSON AFB OHIO F/G 1/2
AIRCRAFT HAZARD DETECTION AND CONTROL UTILIZING AN AIRCRAFT DAT--ETC(U)
DEC 77 D 6 FOX

UNCLASSIFIED

AFAPL-TR-77-77

NL

| of |

AD
2054416



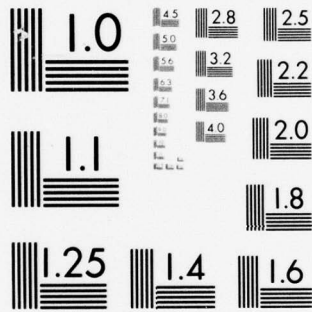

MICROCOPY RESOLUTION TEST CHART
NATIONAL BUREAU OF STANDARDS-1963-A

FOR FURTHER TRAN



2

AFAPL-TR-77-77

AD A 054416

AIRCRAFT HAZARD DETECTION AND CONTROL UTILIZING AN AIRCRAFT DATA ACQUISITION SYSTEM

AD No. _____
DDC FILE COPY

Fire Protection Branch
Fuels and Lubrication Division

December 1977
TECHNICAL REPORT AFAPL-TR-77-77
Final Report for Period **JULY 1970 - JULY 1974**

Approved for public release; distribution unlimited

DDC
RECEIVED
MAY 30 1978
B

AIR FORCE AERO PROPULSION LABORATORY
AIR FORCE WRIGHT AERONAUTICAL LABORATORIES
AIR FORCE SYSTEMS COMMAND
WRIGHT-PATTERSON AIR FORCE BASE, OHIO 45433

NOTICE

When Government drawings, specifications, or other data are used for any purpose other than in connection with a definitely related Government procurement operation, the United States Government thereby incurs no responsibility nor any obligation whatsoever; and the fact that the government may have formulated, furnished, or in any way supplied the said drawings, specifications, or other data, is not to be regarded by implication or otherwise as in any manner licensing the holder or any other person or corporation, or conveying any rights or permission to manufacture, use, or sell any patented invention that may in any way be related thereto.

This report has been reviewed by the Information Office (OI) and is releasable to the National Technical Information Service (NTIS). At NTIS, it will be available to the general public, including foreign nations.

This technical report has been reviewed and is approved for publication.

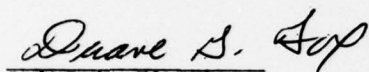
DUANE G. FOX
Project Engineer

FOR THE COMMANDER

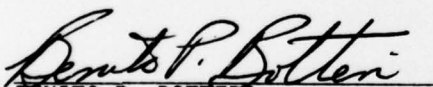
BENITO P. BOTTERI
Chief, Fire Protection Branch
Fuels & Lubrication Division
Air Force Aero Propulsion Laboratory

"If your address has changed, if you wish to be removed from our mailing list, or if the addressee is no longer employed by your organization please notify AFAPL/SFH, W-PAFB, OH 45433 to help us maintain a current mailing list".

Copies of this report should not be returned unless return is required by security considerations, contractual obligations, or notice on a specific document.

UNCLASSIFIED

SECURITY CLASSIFICATION OF THIS PAGE (When Data Entered)

REPORT DOCUMENTATION PAGE		READ INSTRUCTIONS BEFORE COMPLETING FORM
1. REPORT NUMBER AFAPL-TR-77-77	2. GOVT ACCESSION NO.	3. RECIPIENT'S CATALOG NUMBER
4. TITLE (and Subtitle) AIRCRAFT HAZARD DETECTION AND CONTROL UTILIZING AN AIRCRAFT DATA ACQUISITION SYSTEM		5. TYPE OF REPORT & PERIOD COVERED Final Technical Report, Jul 73 - Jul 74
7. AUTHOR(s) Duane G./Fox	8. CONTRACT OR GRANT NUMBER(s)	
9. PERFORMING ORGANIZATION NAME AND ADDRESS Air Force Aero-Propulsion Laboratory (SFH) Air Force Wright Aeronautical Laboratories, AFSC Wright-Patterson AFB, Ohio 45433		10. PROGRAM ELEMENT, PROJECT, TASK AREA & WORK UNIT NUMBERS Program Element 62203F Project 3048 Task 304807 Work Unit 30480741
11. CONTROLLING OFFICE NAME AND ADDRESS Air Force Aero-Propulsion Laboratory (SF) Air Force Wright Aeronautical Laboratories, AFSC Wright-Patterson AFB, Ohio 45433		12. REPORT DATE Dec 1977
14. MONITORING AGENCY NAME & ADDRESS (if different from Controlling Office)		13. NUMBER OF PAGES 89
		14. SECURITY CLASS. (of this report) Unclassified
15a. DECLASSIFICATION/DOWNGRADING SCHEDULE		
16. DISTRIBUTION STATEMENT (of this Report) Approved for public release; distribution unlimited.		
17. DISTRIBUTION STATEMENT (of the abstract entered in Block 20, if different from Report)		
18. SUPPLEMENTARY NOTES		
19. KEY WORDS (Continue on reverse side if necessary and identify by block number) Hazard Detection Fire Protection Data Acquisition Multiplexed Data Acquisition Fire Detection		
20. ABSTRACT (Continue on reverse side if necessary and identify by block number) This report summarizes the results of an in-house program which demonstrates the feasibility of using an aircraft multiplexed data acquisition system for on-board aircraft hazard detection and control. The hazards of primary interest are fire, explosion, overheat, smoke, and explosive vapors. Hazard control involves system shutdown as well as activation of extinguishing systems and other active protective systems. This program involves both concept formulation and the design of breadboard hardware to demonstrate these concepts.		

DD FORM 1 JAN 73 1473

EDITION OF 1 NOV 65 IS OBSOLETE

UNCLASSIFIED

SECURITY CLASSIFICATION OF THIS PAGE (When Data Entered)

011 570

next page

207

UNCLASSIFIED

SECURITY CLASSIFICATION OF THIS PAGE(When Data Entered)

Advanced aircraft will have multiplexed data acquisition systems with central computers for a variety of applications. Hazard detection is shown to be a small part of the total aircraft data system requirements. It is shown that hazard detection subsystem complexity and cost are reduced by using a data system and computer on a "time-shared" basis.

UNCLASSIFIED

SECURITY CLASSIFICATION OF THIS PAGE(When Data Entered)

AFAPL-TR-77-77

FOREWORD

This report describes an in-house effort conducted by personnel of the Fire Protection Branch (SFH), Fuels and Lubrication Division (SF), Air Force Aero Propulsion Laboratory, Air Force Wright Aeronautical Laboratories, Wright-Patterson Air Force Base, Ohio, under Project 3048, "Fuels, Lubrication and Fire Protection," Task 304807, "Aerospace Vehicle Fire Protection."

This work reported herein was performed during the period under the direction of the author, Duane G. Fox, project engineer. The report was released by the author in October 1977.

ACCESSION for		
NTIS	White Section	<input checked="" type="checkbox"/>
DDC	Buff Section	<input type="checkbox"/>
UNANNOUNCED		<input type="checkbox"/>
JUSTIFICATION		
BY		
DISTRIBUTION/AVAILABILITY CODES		
Dist.	MAIL	and/or SPECIAL
A		

TABLE OF CONTENTS

SECTION		PAGE
I	INTRODUCTION AND SUMMARY	1
	1. Introduction	1
	2. Summary	1
II	HISTORICAL BACKGROUND	3
	1. Present Hazard Detection Systems	3
	2. Aircraft Multiplexed Data Acquisition Systems	3
III	HAZARD PROTECTION SYSTEM CONCEPT	7
	1. Introduction	7
	2. General System Description	7
IV	HAZARD DETECTORS	13
	1. Overheat and Temperature Detectors	13
	a. Point Location Overheat Sensor	13
	b. Point Location Temperature Sensor	15
	c. Continuous Element Overheat Sensor	16
	2. Fire Detectors	20
	a. Semiconductor Sensor	20
	b. Gas Discharge Tube Sensor	22
V	HAZARD CONTROL TECHNIQUES	24
	1. Passive Control Measures	24
	2. Active Control Measures	24
	3. Multiplex System Operated Hazard Control Measures	24
VI	AIRCRAFT DATA SYSTEM REQUIREMENTS	27
	1. Large Aircraft (CARGO, TANKER)	27
	a. General Discussion	27
	b. Engine Nacelles	27

TABLE OF CONTENTS (CONCLUDED)

SECTION	PAGE
c. Auxiliary Power Unit Compartments	29
d. Dry Bays	29
e. Cargo Bays	31
f. Wheel Well Compartments	31
g. Crew Compartments	31
h. Required System Capacities	31
2. Small Aircraft (Fighter)	32
VII LABORATORY BREADBOARD SYSTEM	34
1. General Description	34
2. Hardware	34
3. Schematics	40
VIII FUTURE SYSTEM RECOMMENDATIONS	77
REFERENCES	79

LIST OF ILLUSTRATIONS

FIGURE		PAGE
1	Typical Aircraft Hazard Zones	4
2	Typical Multiplex Data Acquisition System	6
3	Multiplexed Hazard Detection System	8
4	Dedicated MUX Terminal	11
5	Shared MUX Terminal	12
6	Point Location Overheat Sensor	14
7	Bridge Circuit for Thermistor	16
8	Overheat Cable Continuous Self Checking Circuit	18
9	Overheat Cable Sampling Self Checking Circuit	19
10	Ultraviolet and Infrared Optical Type Flame Detectors	21
11	Typical UV Sensor Output Signal	23
12	MUX Operated Extinguishing System	25
13	Large Aircraft Hazard Protection	28
14	Breadboard System Data Acquisition System (Aircraft Components)	35
15	Complete Breadboard Data System	36
16	Engine Nacelle Sensor Simulator	38
17	Aircraft Multiplexed Hazard Detection Laboratory Breadboard System	39
18	Overheat Sensors 1A and 1B Wiring	41
19	Overheat Sensor Wiring on Engine Simulator	42
20	Fire Sensors 1A and 1B Wiring	43
21	Fire Sensors 2A and 2B Wiring	44
22	Breadboard Unit Module No. 6, UV Sensor Bias Electronics	45
23	Breadboard Unit Module No. 8, UV Sensor Signal Processor	46
24	Fire Sensors 3A and 3B Wiring	48

LIST OF ILLUSTRATIONS (CONCLUDED)

FIGURE		PAGE
25	Breadboard Unit Module No. 5, UV Sensor Bias Electronics	49
26	Breadboard Unit Module No. 7, UV Sensor Signal Processor	50
27	Fire Sensors 4A and 4B Wiring	52
28	Test Source 1A and 1B Wiring	53
29	Test Source 2A and 2B Wiring	54
30	Test Source 3A and 3B Wiring	55
31	Miscellaneous Circuits	56
32	Typical Extinguishing Container Transducer	57

LIST OF TABLES

TABLE		PAGE
1	Binary Resolution	15
2	Summary of Large Aircraft Hazard Protection	32
3	Summary of Small Aircraft Hazard Protection	33
4	Connector Cable Plug and Receptacle Types	58
5	Wiring List: Connector A, Multiplex System Remote Output Terminal	59
6	Wiring List: Connector B, Multiplex System Remote Input Terminal No. 1	61
7	Wiring List: Connector D, Crew Readout	62
8	Wiring List: Connector E, Crew Readout	63
9	Wiring List: Connector F, Sensor Fault Indicator Unit	64
10	Wiring Lists: Connector G, Maintenance Warning Unit	65
11	Wiring List: Connector H, Engine Simulator Unit	66
12	Wiring List: Connector I, Engine Simulator Unit	67
13	Wiring List: Connector J, Sensor Breadboard Electronic Unit	68
14	Wiring List: Connector L, Breadboard Sensor Electronic Unit	69
15	Wiring List: Connector K, Breadboard Sensor Electronic Unit	70
16	Wiring List: Interconnection Between Connectors A, D, F, and I	71
17	Wiring List: Interconnection Between Connectors A, D, F, and I	72
18	Wiring List: Interconnection Between Connectors C and J	73
19	Wiring List: Interconnection Between Connectors G and H	74
20	Wiring List: Connector C, Multiplex System Remote Terminal No. 2	75
21	Wiring List: Interconnection Between Connectors B and D	76

SECTION I
INTRODUCTION AND SUMMARY

1. INTRODUCTION

This program was initiated to study the feasibility of using an on-board aircraft data acquisition system to obtain information from hazard detectors such as fire, overheat, and explosion sensors and provide the crew with a warning of the hazard.

It is recognized that many future aircraft will have multiplexed data acquisition systems and central aircraft computers for a variety of applications which include electrical power distribution and control of avionic systems. The types of information signals from hazard detectors and the handling of these signals are similar in nature to those in other aircraft systems which will be using multiplexed data acquisition systems. It is apparent then, that a hazard detection system can also use the multiplexed data acquisition system. Since the data system will be shared by several subsystems on the aircraft, it is necessary to adequately define the data system performance requirements and the system capacities for hazard detection early in the development of the aircraft. This study provides the background information required to make that early determination of the system requirements.

This program involved both concept formulation and the development of breadboard hardware for testing of these concepts. The breadboard hardware consisted of an off-the-shelf multiplexed data acquisition system with a programmable memory and in-house developed interfacing electronics and other required hardware.

2. SUMMARY

It must be recognized that the hazard detection signal transfer required on an aircraft is a small part of the total information transfer requirements on that aircraft. Any attempt to force special requirements on the data system which are not required by other larger users of the data system is not practical. The emphasis on this program has been to develop

AFAPL-TR-77-77

techniques for operating the hazard detection subsystem with a standard data system such as that specified in MIL-STD-1553A (Reference 12). Fortunately, not many compromises are required for the hazard detection subsystem because the signal transfer requirements are similar to other subsystem requirements.

It is shown that utilization of a central aircraft computer can simplify a hazard detection subsystem by eliminating the need for special purpose computer-like hardware. All hazard detection and control measures require reliable hardware to ensure freedom from false warnings. Utilization of a redundant data acquisition and computer system will provide the required high reliability.

SECTION II

HISTORICAL BACKGROUND

1. PRESENT HAZARD DETECTION SYSTEMS

Separate detection systems are usually provided in each zone of the aircraft for which the detection of the occurrence of a hazardous condition is needed. On some aircraft these areas are limited to engine nacelles and auxiliary power unit compartments. As illustrated in Figure 1, other zones in many aircraft which often have detection systems include dry bays around fuel compartments, landing gear compartments, and gun compartments. Experience with operational systems has shown, in general, a poor reliability, a high false warning rate, and usually inadequate detection (Reference 1). Redundancy has been used to decrease the false warning rate (Reference 2) and optical fire detectors have been developed to provide more adequate fire detection capability (References 3, 4, 5, and 6). Optical flame sensors can be used in most areas of the aircraft for fire detection.

A system known as the Integrated Fire and Overheat Detection System (Integrated System) was developed by the AFAPL for engine nacelle installations (References 7 and 8). This system combines optical fire detectors, continuous element overheat detectors, and a self-checking computer control into a single system. This development was the first effort to combine different types of detectors into a single system. The Integrated System has overcome the problem of missed fires and false fire warnings. It is, however, still limited to a single aircraft hazard zone and requires a special purpose computer within the system to solve the logic equations associated with redundancy and self testing.

2. AIRCRAFT MULTIPLEXED DATA ACQUISITION SYSTEMS

Multiplexed data acquisition systems have been developed for several aircraft applications which include the distribution of electrical power, the control of avionics and communication systems, and flight control. Initial developments in each area involved developing a multiplexed data system to transfer information from one point to another and, if required,

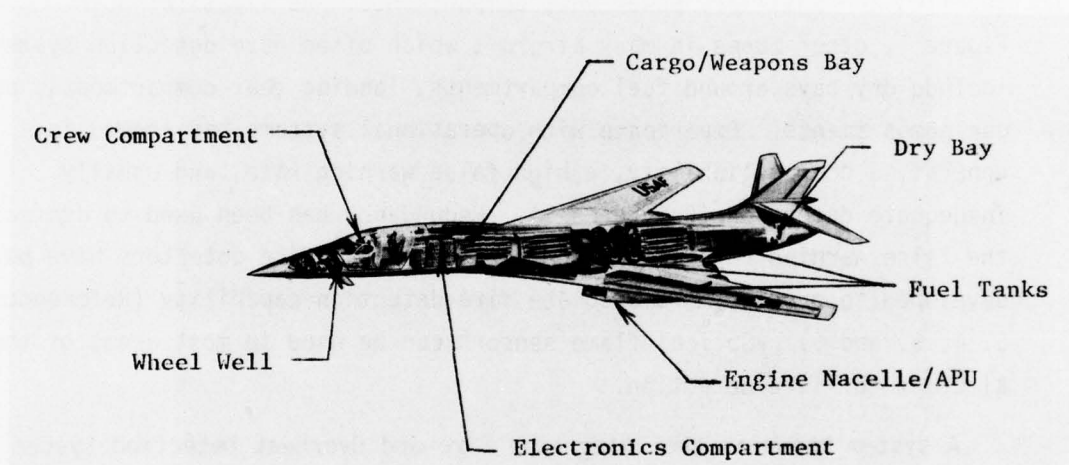

Figure 1. Typical Aircraft Hazard Zones

AFAPL-TR-77-77

provide computer operation on that data. A typical data system is shown in Figure 2. Although each application has unique problems associated with multiplexing, many requirements of multiplexing are similar in each system. This fact was soon recognized by personnel working in these technical areas (Reference 9). There are then, many advantages to be gained by standardizing the hardware components in the data system, such as the remote terminals, data line, and central processor. These advantages include cost reduction and simplification. The data bus operation has been standardized and is specified in MIL-STD-1553A (Reference 12). An aircraft may have several data systems on-board to provide a sufficient capacity; however, each system will be compatible with the others and data transfer between them possible. A subsystem designed to operate with a data system on a particular aircraft will also be operable on another aircraft which uses the standard data system.

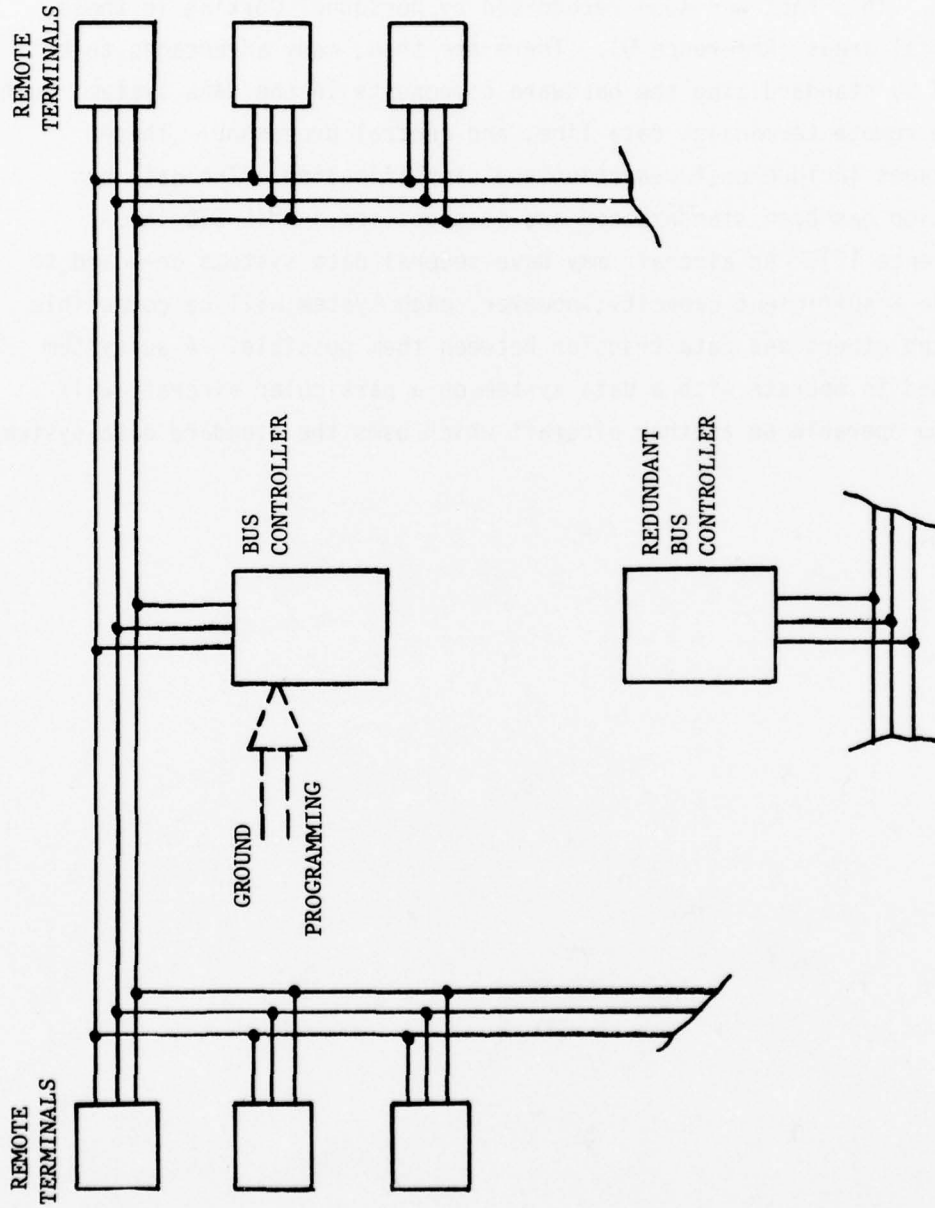

Figure 2. Typical Multiplex Data Acquisition System

SECTION III

HAZARD PROTECTION SYSTEM CONCEPT

1. INTRODUCTION

This section of the report will discuss in general terms the system concept. Each part of the system will be discussed in greater detail in later sections. No attempt will be made to relate the general system to a specific aircraft at this time. An operational aircraft system would be configured to meet the requirements of that aircraft. Several typical applications (i.e., fighter, bomber, cargo) with estimates on number and location of sensors are included in Section VI of this report.

2. GENERAL SYSTEM DESCRIPTION

A hazard detection and control system on an aircraft can utilize a data acquisition system to collect status information from numerous sensors and associated interface electronics which are located at various points in the aircraft. It can also use the data system to operate crew readouts, supply maintenance information, and activate control devices such as extinguisher systems. A typical system is illustrated in Figure 3.

The data system consists of the Central Processor Unit (CPU), the data bus, and the remote terminals (RT's). The data system shown in this report is typical of those currently being envisioned. Actual operational systems may vary somewhat in detailed operation and in terminology. The general operating characteristics of an operational aircraft system will, however, be similar. The reader is encouraged to investigate the literature further to find the latest hardware and system operation being developed for a particular application. Although shown as a non-redundant system in drawings and descriptions in this report, an operational system would employ redundancy to achieve a high reliability. This high reliability is as important for hazard detection and control as it is for other aircraft subsystems. The redundant electronic boxes and data lines can also be physically separated to provide a high degree of survivability from physical damage. This would be especially important in combat aircraft.

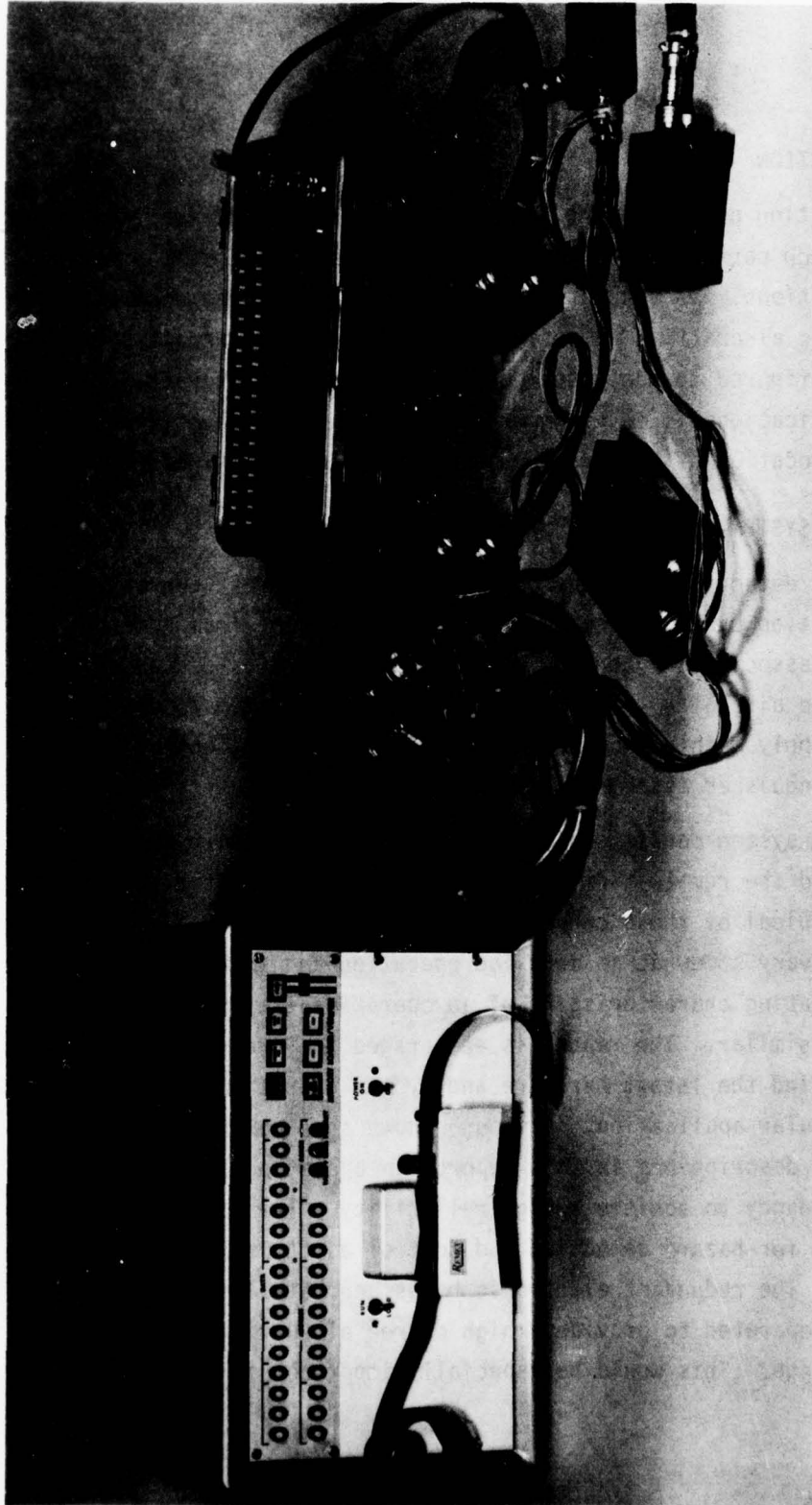

Figure 3. Multiplexed Hazard Detection System

The Central Processor Unit is capable of performing both arithmetic and logic operations. Most of the operations of the CPU for hazard detection and control are solutions of simple logic equations and direct information transfer. The logic equations result primarily from redundant sensor systems which require two sensors to be activated before a crew warning is given. Although some of these equations may be a simple logical "AND" operation, most equations become more complex when automatic self testing of the sensor and switch-out after sensor failure are incorporated in the system. Several examples of equations which occur in actual systems are developed in Section VII of this report. Other hazard sensors, such as thermocouples, require arithmetic operations, which include determining and possibly indicating the actual temperature of some aircraft component.

The information transfer and operations performed by the CPU are controlled by a program stored in a memory associated with the CPU. Since this memory will be programmable, it is flexible to change. The format for this software will be given in a specification presently being developed by the Air Force. Programming in this report will be written in the form of Boolean equations and arithmetic operations.

The data bus consists of a simple, twisted, shielded pair of wires which can operate at data rates up to 2MH_z , although 1MH_z is typical. Faster systems incorporating new technologies such as fiber optic data lines are being developed (Reference 10). Time division multiplexing has been shown to be a good method of encoding the data for transmission on the data bus (Reference 11). With the data bus operation now standardized, data transfer between different systems is possible.

The Remote Terminals (RT's) consist of the Multiplex Terminal Unit (MTU) and the Subsystem Interface Unit (SSIU). The MTU encodes the data from the SSIU for transmission on the data bus on command from the CPU. It also decodes information from the data bus and inputs it to the SSIU. The MTU will eventually be standardized and will most likely be available as a Large Scale Integration (LSI) package for inclusion in the Remote Terminal.

The Subsystem Interface Unit converts the signals from the subsystem to the form required for the MTU. The SSIU is dependent on the subsystem application and will vary in design accordingly. In installations in which there are a large number of signals required for hazard detection (such as an engine nacelle) the RT could be dedicated for hazard detection only and would then be designed by the hazard detection subsystem manufacturer. This installation is shown in Figure 4. In other applications, in which there are only a few hazard signals, these signals would need to be input to the data system through an RT dedicated to another function such as electrical power control. This requirement exists because each data bus is typically limited to 32 RT's and therefore the signals must be grouped together to maximize the signals at each RT. In this case the signal from the hazard detection subsystem would need to be compatible with the SSIU which is designed primarily for the other use. This will represent no major problem to hardware designers but does require the proper designation of signal types early in the development of a system. This type of installation is illustrated in Figure 5.

A Remote Terminal can be designed to accept discrete, analog, or digital information signals. Since a discrete signal requires the least data bits (one bit) for transmission, it is best to use discrete information if possible. This will reduce the bit capacity required on the data bus and permit a higher level of use of the data bus.

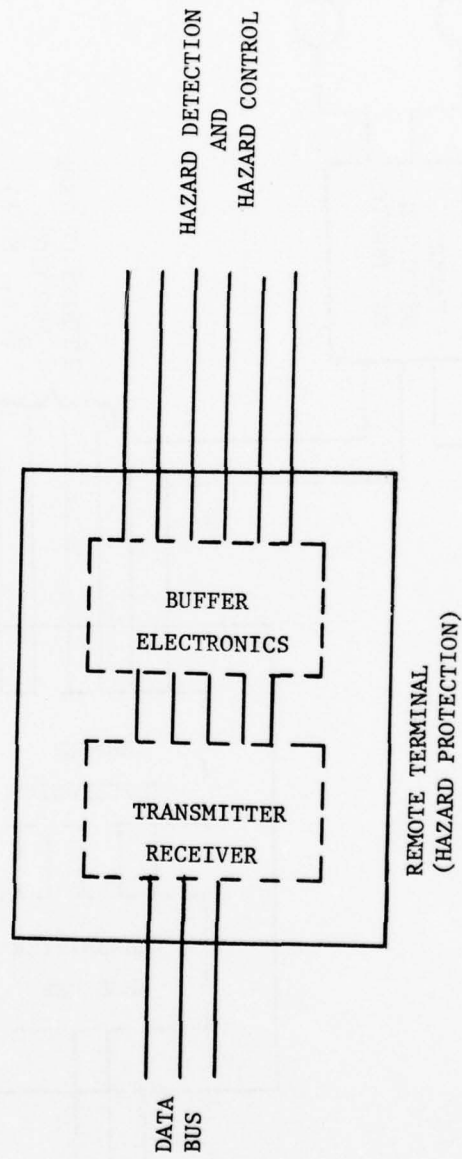

Figure 4. Dedicated MUX Terminal

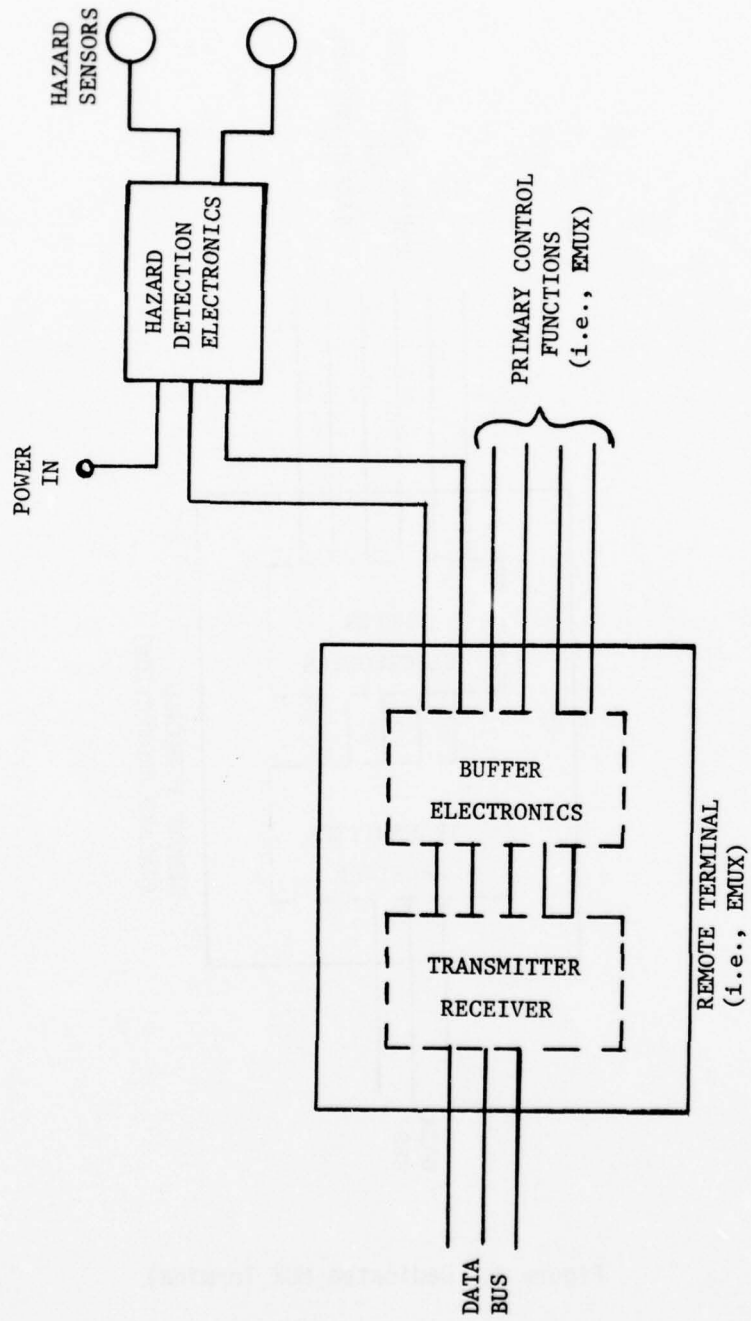

Figure 5. Shared MUX Terminal

SECTION IV
HAZARD DETECTORS

The various types of hazard detectors presently in use or available for use will be discussed in this section to familiarize the reader with this technology. Many good references are available for more detailed reading and will be indicated where appropriate. Specifically, References 12 and 13 give good detailed explanations of many of the detectors.

1. OVERHEAT AND TEMPERATURE DETECTORS

Overheat and temperature detectors are used to sense overheat conditions which result from sources such as bleed-air line leaks, fuel or oil fires, and component part failures. An overheat detector can be a point location type that detects at a small localized location or a volume averaging type such as a continuous element sensing cable.

a. Point Location Overheat Sensor

A point location overheat sensor is one of the simplest hazard sensors to be implemented with a data system because it requires no electronics (other than a load resistor in some cases) to interface the sensor with the remote terminal. It is, however, limited in application on an aircraft because of the limited volume coverage obtained with the sensor. A point location overheat sensor can be used to protect a critical component such as an engine mount from excessive temperature. Although it is not a fire detector, it is sometimes used to detect overheat resulting from a fire. The signal from the sensor does not, however, indicate what the cause of the overheat is.

The bi-metal switch type of point location overheat sensor is the most common and can be operated as shown in Figure 6. Circuit 6a is the simplest, from an installation viewpoint, because the aircraft frame can be used as one side of the circuit. A simple short to ground in the wiring, however, will cause a false signal. Circuit b provides a higher assurance of a true overheat warning because a single short in the aircraft wiring to ground cannot cause a false signal. It does require two wires for interconnecting to the sensor and the electronics unit.

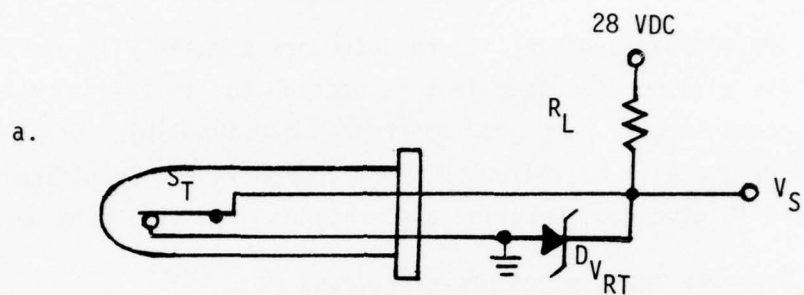

$V_S = V_{RT}$ Normal

$V_S = 0$ Volt Overheat

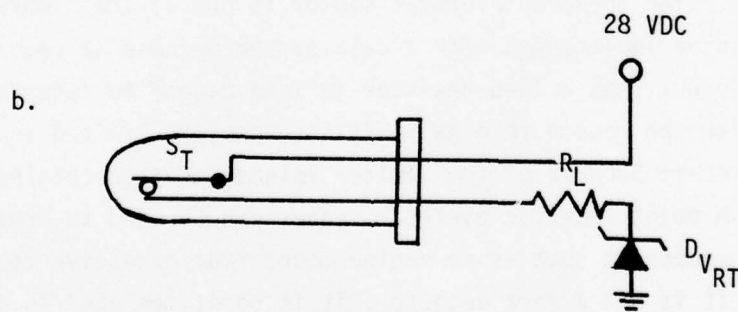

$V_S = 0$ Normal

$V_S = V_{RT}$ Overheat

Figure 6. Point Location Overheat Sensor

b. Point Location Temperature Sensor

A point location temperature sensor differs from an overheat sensor because it provides a signal proportional to the sensor temperature. This type of sensor includes thermocouples and thermistors. Thermocouple signals are typically in the millivolt range and thus need some amplification before being input to the data system. Normally, an analog to digital (A/D) converter would be incorporated with the subsystem interface unit and the digital value of the temperature transmitted on the data system. The number of bits required for the signal depends on the resolution of temperature required. Table 1 shows typical resolutions available with various A/D converters. Eight bits of data would be required in most applications.

TABLE 1
BINARY RESOLUTION

2^{-n}	$1/2^n$ (Decimal)	%
2^{-0}	1.0	100
2^{-1}	0.5	50
2^{-2}	0.25	25
2^{-3}	0.125	12.5
2^{-4}	0.0625	6.2
2^{-5}	0.03125	3.1
2^{-6}	0.015625	1.6
2^{-7}	0.007812	0.8
2^{-8}	0.003906	0.4
2^{-9}	0.001953	0.2
2^{-10}	0.0009766	0.1
2^{-11}	0.00048828	0.05
2^{-12}	0.00024414	0.024

A thermistor provides the same information as a thermocouple except that the signal is generated by an external energy source. The thermistor is often used in a bridge circuit as shown in Figure 7 to generate a voltage proportional to temperature. The same criterion for selection of resolution would also apply to this sensor.

If the only information required is knowing that a pre-determined temperature is exceeded, then the signal processing can be performed by the remote terminal with a circuit such as a voltage comparator and a discrete signal input to the data system. This would reduce significantly the required number of data bits.

c. Continuous Element Overheat Sensor

Although there are many types of continuous element overheat detectors, they all have the property of being capable of sensing a temperature which is above the cable set point (alarm) temperature over a portion of the length of the sensor. The sensor, which looks like a wire, is mounted in the compartment that is being protected. The alarm temperature is set during manufacture by varying the cable characteristics and sometimes the associated cable electronics. The most common cable construction is a coaxial type cable with the inner conductor and outer

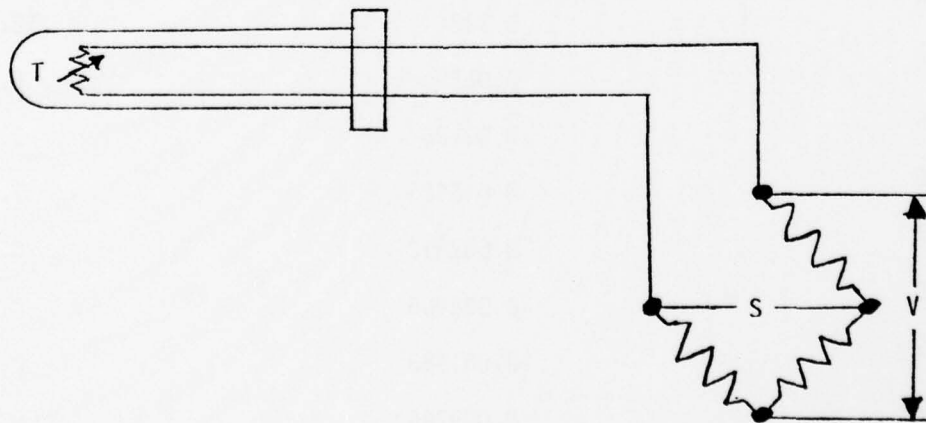

Figure 7. Bridge Circuit for Thermistor

sheath separated by a temperature sensitive material. The signal from the cable may be a change in resistance which can be sensed by an electronic circuit to obtain a warning signal when a portion of the cable is above the alarm temperature.

There are several types of overheat systems described in References 14 and 15. The operation of these different types of cables and associated electronics can be generalized, however, into a common characteristic. The signal from the sensor electronics is a discrete change of state when the cable senses the temperature reaching the cable alarm temperature. This discrete information can be input to a data system Remote Terminal in the same manner as that from a point location sensor.

Since this type of cable is often located in a rather severe environment, it is susceptible to physical damage. It is usually desired to check the cable periodically to determine operational integrity. It is not tested by applying a heat source to the cable, but rather by monitoring the cable for an electrical short or open circuit condition. Again, this test will depend on the type of cable. This test function is performed by the cable electronic circuit and can be done in two ways. The technique used will be determined by the cable characteristics and system performance requirements.

The cable can be monitored continuously as illustrated in Figure 8. Techniques such as operating the cable in a bridge circuit and looking for an unbalanced condition have been used (Reference 7). A separate output signal channel is required for the cable integrity information.

A second circuit can be used which does not require a separate channel for the sensor test signal and is shown in Figure 9. The sensor checking occurs only on command from the central processor. Although for a single sensor the number of data channels in the two cases is the same (two), the signal channel used for activating the sensor integrity circuits would be used for other sensors in the system and thus the total number of channels is reduced. Since the sensor warning signal

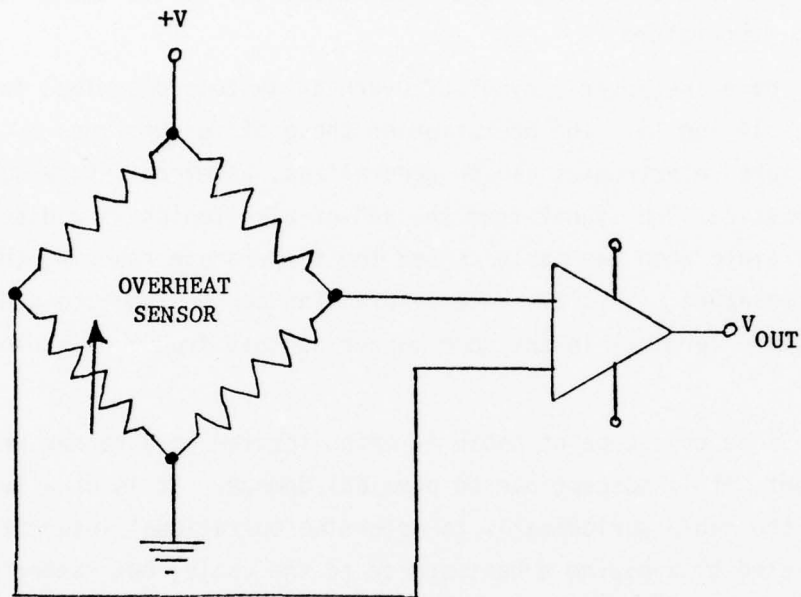

$$\begin{aligned}V_{OUT} &= +V \quad (\text{NORMAL}) \\V_{OUT} &= \frac{+V}{2} \quad (\text{OVERHEAT}) \\V_{OUT} &= 0 \quad (\text{SENSOR SHORTED})\end{aligned}$$

Figure 8. Overheat Cable Continuous Self Checking Circuit

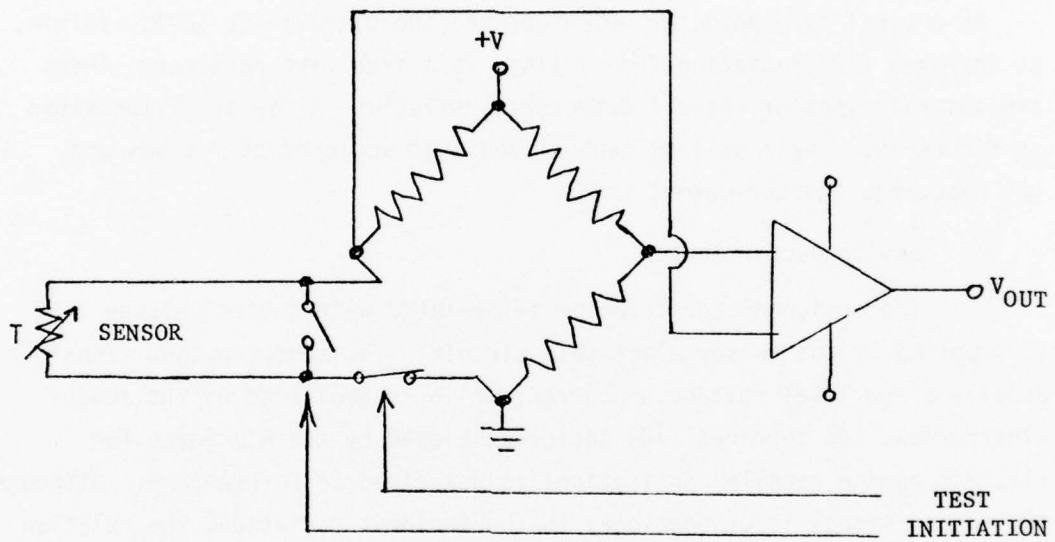

$V_{OUT} = +V$ (NORMAL)

$V_{OUT} = 0$ (OVERHEAT)

$V_{OUT} = 0$ (CIRCUIT TEST)

Figure 9. Overheat Cable Sampling Self Checking Circuit

and the integrity signal are present on the same channel, the central processor must now keep track of the signal timing so that a false warning is not generated from the test signal. These types of system operation characteristics will be discussed in a later section of the report.

2. FIRE DETECTORS

An optical type detector which detects the ultraviolet (UV), visible, or infrared (IR) radiation from a flame is a true fire detector. There are several types of optical detectors available. A few are illustrated in Figure 10. These will be generalized into semiconductor types and gas discharge (geiger-muler) tubes.

a. Semiconductor Sensor

The semiconductor detector is operated with a bias voltage that is supplied by the sensor electronic circuit. The sensor output signal is usually a low level voltage or current which is amplified by the sensor electronics. An infrared (IR) sensor developed by the Air Force for aircraft engine nacelle applications is described in Reference 5. Although the sensor signal is proportional to the incident radiation, the relationship of the fire size or location to the incident radiation cannot usually be determined accurately. Factors such as line-of-sight obstructions and deposits on the sensor window and other reflective surfaces make it impossible to predict the size or location of a flame that is in the optical field of view of the sensor. Usually a sensor output signal which represents the minimum level of detection is chosen as the threshold level. Any sensor signal greater than this minimum is considered a fire warning signal. The useful information from the sensor in this application is thus a discrete type of signal. For sensor information of this type, the signal processing would be done by the sensor electronics and a discrete signal input to the data system. The signal processing might involve simple DC threshold detectors, filtering, or other non-complex electronic operations.

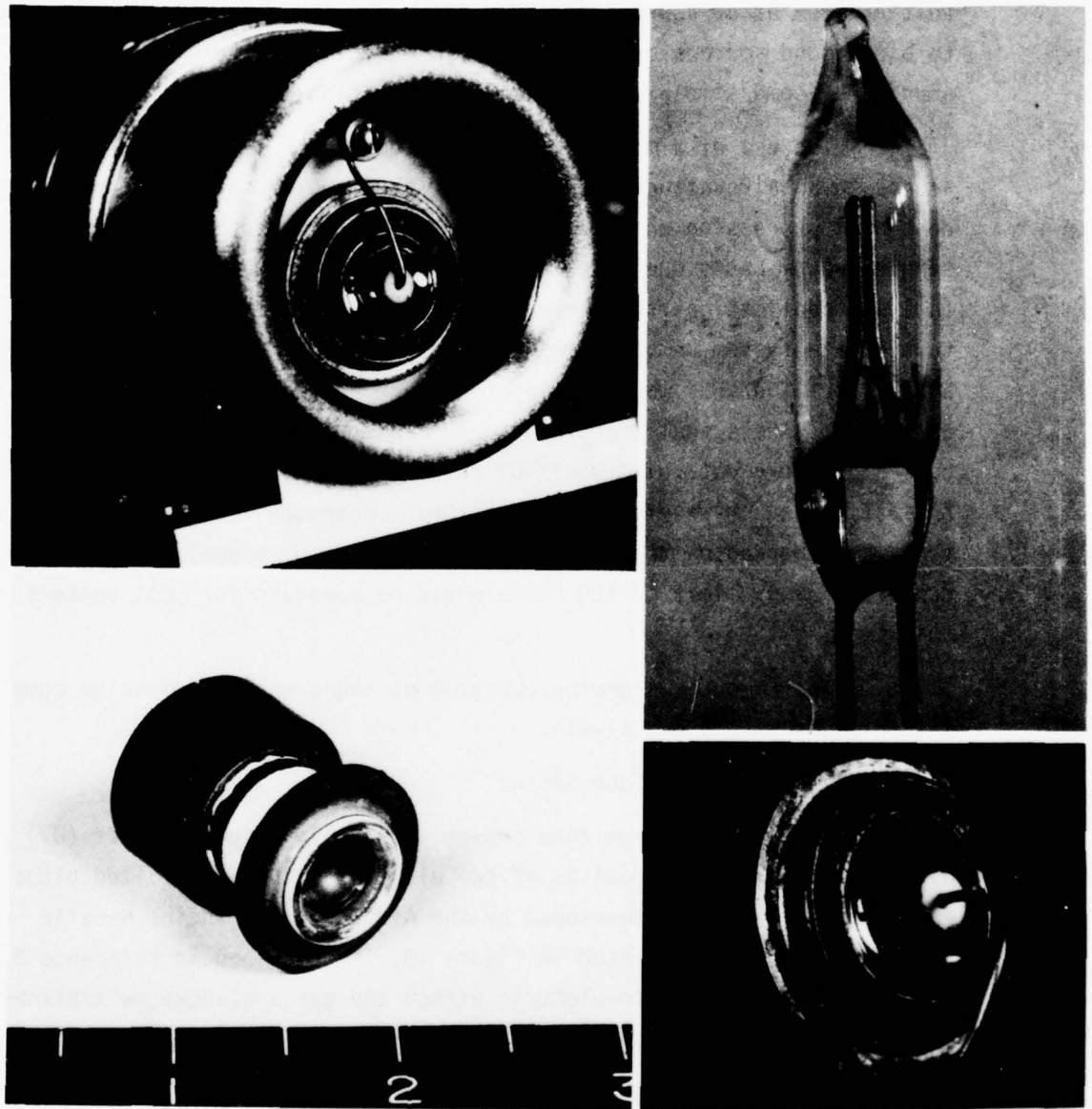

Figure 10. Ultraviolet and Infrared Optical Type Flame Detectors

One primary problem with any type of fire detector is discriminating a sensor signal resulting from a fire from a sensor signal resulting from other sources (background). Some sensors are not responsive to background sources or can be made insensitive to these background sources by some simple electronic discrimination.

The use of a multiplexed data acquisition system which has access to an aircraft central processor or computer makes it possible to do signal processing on the sensor signal which would be prohibited on a single sensor basis due to complex and expensive hardware requirements. In these applications the sensor signal after amplification can be input to the data system remote terminal. Most likely the signal would be of analog form and thus would be input through an analog-to-digital (A/D) converter. The signal transfer requirements would be greater in this case since more data bits would be required for sufficiently transferring the active sensor waveform to the aircraft computer. The signal sampling time would depend on the frequencies in the sensor signal; however, an upper frequency limit of 100 Hertz would be adequate for most sensors of this type.

The computer signal processing on the signal may involve complex filtering or waveform analysis.

b. Gas Discharge Tube Sensor

The gas discharge tube sensor is usually an ultraviolet (UV) detector. The sensor consists of two electrodes in a gas-filled glass envelope. A UV sensor developed by the Air Force for engine nacelle application, and illustrated in Figure 10, is described in Reference 3. The sensor uses the photo-electric effect and gas avalanche multiplication to generate voltage or current pulses when UV radiation impinges upon the sensor electrodes. A typical output pulse train generated by a sensor and associated bias circuit is shown in Figure 11. The pulse rate is related to the intensity of UV radiation. As with the semiconductor sensor, the signal processing can be performed by the sensor electronic circuit and a discrete signal input to the data system. The usual signal processing involves counting the pulses for a period of time. If a threshold count rate is exceeded, a discrete signal can be input to the data system.

If a more complex analysis of the pulses is required that would best be performed by the aircraft computer, then the pulse train information would need to be transferred on the data system. The typical sensor signal is a pulse rate as high as 1000 pulses per second with a pulse width of 0.75 millisecond. It should be realized that a high data rate would be required to accomplish this task, and a large bit capacity would be required if there were several sensors. A typical engine nacelle installation for instance may have up to twelve UV sensors.

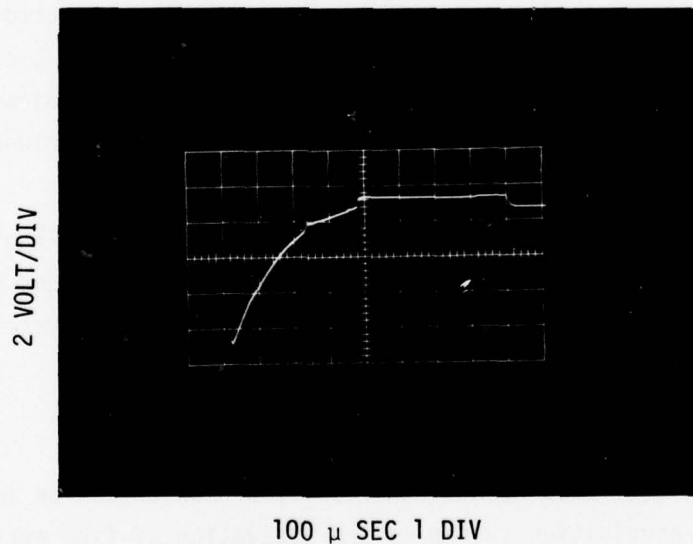

Figure 11. Typical UV Sensor Output Signal

SECTION V

HAZARD CONTROL TECHNIQUES

1. PASSIVE CONTROL MEASURES

Many passive measures are provided in aircraft to eliminate or control hazards. Venting leaking fluids or vapors is an example of a technique used to control explosions and fires. Since passive control measures are designed in during aircraft manufacture and are in operation at all times, they do not need any activation and will not have any requirements for the multiplex system. In a few instances, status information on a passive control may be required. These would most likely be on-off type signals.

2. ACTIVE CONTROL MEASURES

Overheat conditions when detected by an overheat detector such as one of those previously discussed can be controlled by one of several techniques. An engine nacelle overheat can sometimes be corrected by reducing the engine thrust. Various types of bleed-air line overheat conditions can be controlled by shutting down applicable lines and equipment. Techniques for extinguishing an engine nacelle fire usually include shutting off fuel flow to that engine.

These types of hazard control involve the operation of equipment which is under the control of other subsystems and would thus be performed by the aircraft E-mux, A-mux, engine control or other subsystems. These will not be discussed further in this report.

3. MULTIPLEX SYSTEM OPERATED HAZARD CONTROL MEASURES

The most widely used hazard control measure which can be implemented with the data acquisition system is the activation of fire extinguishing systems and the monitoring of the extinguishing system status. This subsystem is used exclusively for fire protection. A typical system is illustrated in Figure 12. This system consists of two extinguisher containers each of which has a status sensor (i.e., pressure switch) and a release valve (i.e., pyroelectric). The two separate systems provide a primary and a secondary (backup) source of fire extinguishing agent.

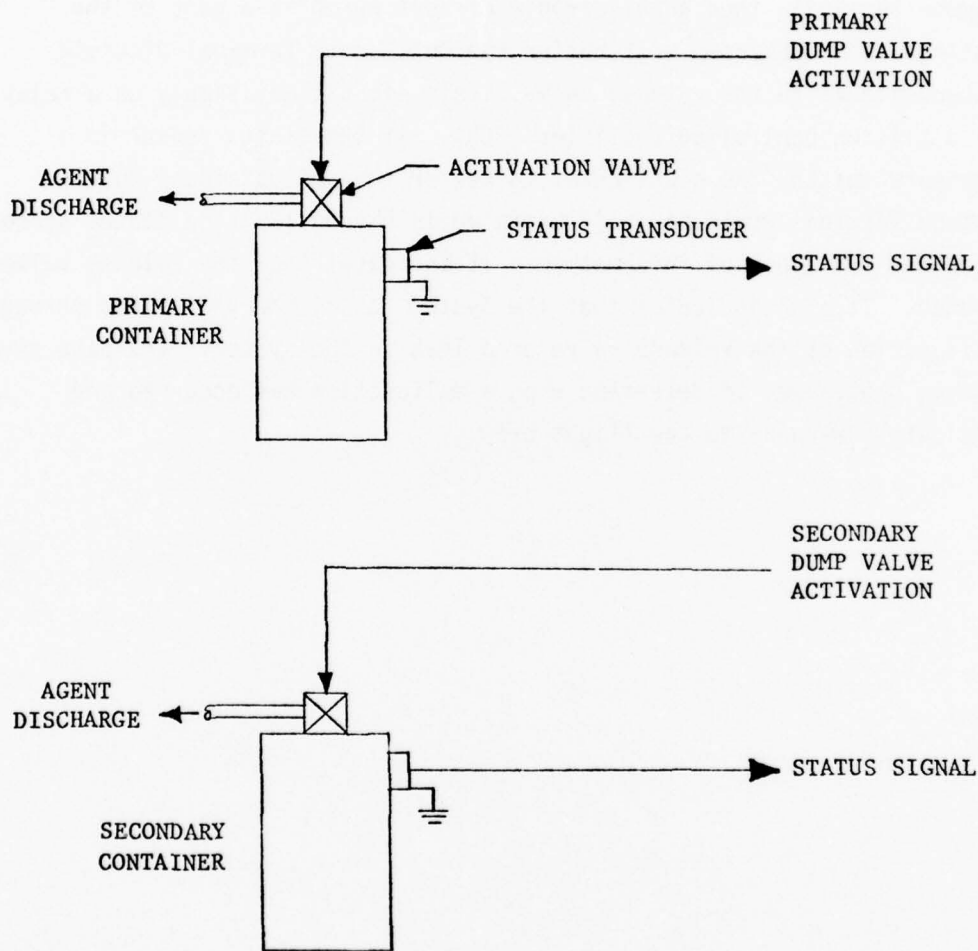

Figure 12. MUX Operated Extinguishing System

AFAPL-TR-77-77

The system is used in engine nacelles, APU compartments, and other potential fire zones. Although other types of release valves and status sensors are used, these examples are typical.

If the fire extinguishing subsystem is not operated by a dedicated remote terminal, then an electronic circuit which is a part of the extinguisher subsystem will buffer the MUX Remote Terminal discrete output signal to the release valve. This circuit may simply be a relay or a silicon controlled rectifier (SCR). If the status sensor is a pressure switch, the electronics to buffer the status signal to the Remote Terminal would be as illustrated in Figure 12. The status sensor provides two types of information. It indicates that the release valve is opened. It also indicates that the system has discharged either through malfunction of the release valve or a leak in the system. The data system can be programmed to determine when a malfunction has occurred and indicate a warning to the flight crew.

SECTION VI

AIRCRAFT DATA SYSTEM REQUIREMENTS

1. LARGE AIRCRAFT (CARGO, TANKER)

a. General Discussion

Hazard detection and control on large aircraft such as cargo and bomber aircraft have the greatest requirement on data acquisition systems. This requirement includes both the number of data inputs and outputs as well as the amount of programming in the central processor. These aircraft also have some operational subsystems such as Central Integrated Test Systems (CITS) that are not available on smaller aircraft. The hazard detection and control subsystem can utilize the CITS for testing of sensors and indicating failures.

The example used here will be a four engine aircraft. A typical aircraft is shown in Figure 13. Cargo bay requirements will be approximately the same for any of the aircraft of this size. Crew compartment requirements will also be nearly the same.

b. Engine Nacelles

As previously mentioned, fire protection in engine nacelles will have the greatest requirements of the data system. Two nacelles can be grouped together and integrated into one remote terminal. The remote terminal will need to be redundant to provide the high level of performance required for the engine nacelle protection system.

A typical engine nacelle of this size would require six redundant optical fire sensors and a redundant pair of overheat detection cables. A discrete signal channel is required for each sensor. Since the remote terminal is dedicated to the protection system, the sensor interfacing electronics can be integrated internally with the remote terminal. The status of the interfacing electronics can be contained in the remote terminal BITE signal. The sensors also require a test signal for checking sensor integrity although one test signal can be used for all the sensors in the nacelle. An extinguishing system with a primary and reserve capability such as previously described will also be included in the engine nacelle protection system.

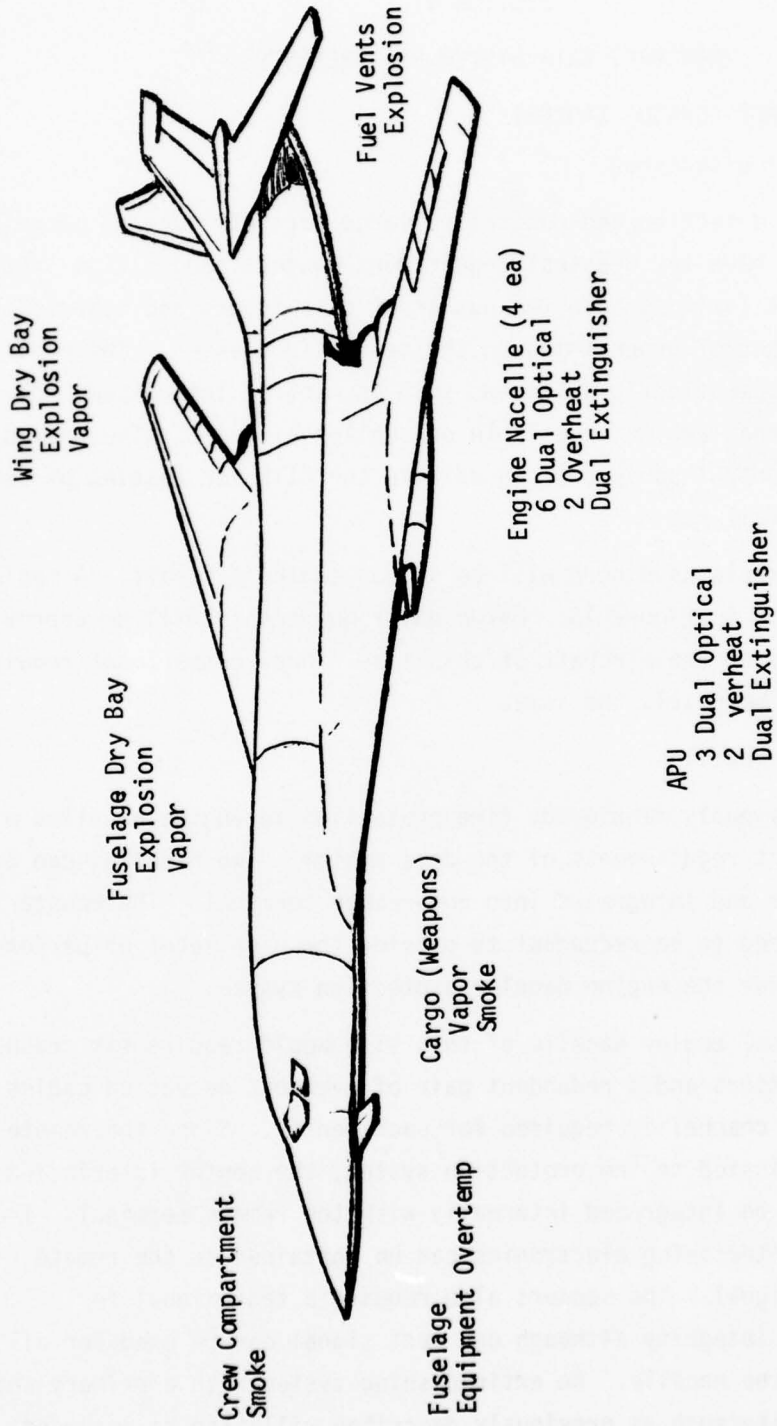

Figure 13. Large Aircraft Hazard Protection

c. Auxiliary Power Unit Compartments

Auxiliary Power Unit (APU) compartments can be protected from fire and overheat by one of two techniques. The technique used is usually determined by the location of the APU and other physical conditions.

Sometimes if the APU is located near an engine nacelle, the detection and extinguishing is provided as a part of the adjacent engine nacelle protection system. In this application the system does not determine in which compartment the hazard exists and both compartments are treated as one.

The system illustrated in Figure 13, however, is a separate system for an APU compartment. Since the compartment is smaller than an engine nacelle, a fewer number of fire detectors are required. The example shows three dual fire detectors and a redundant overheat cable. Operation of this system is nearly identical to the engine nacelle system and includes a dual capability extinguishing system.

It should be noted here that the extinguishing agent storage container may be common with one for an engine nacelle or other dry bay compartment. Several larger containers and associated instrumentation may be less expensive than many more smaller containers. Discharge of the agent into a specific compartment can be controlled by activation of specific control valves. Again, the choice of system will be determined by the type of system and the specific operational requirements. The data acquisition system requirements will be nearly the same for any of the systems.

d. Dry Bays

Dry bay hazard protection is the most non-standard type of protection in the aircraft and is thus the most difficult to characterize. It is highly aircraft dependent. Passive protection such as explosion prevention foams will not be considered in this discussion. Basically, two primary types of hazards can exist in dry bays. Explosions can occur if vapors collect in a closed bay. Fires can occur from the ignition of fuel or hydraulic fluids which leak into closed or vented compartments.

Explosion protection involves detection of the explosion in the first few milliseconds and injecting a suppression agent into the compartment prior to the time that the explosion overpressure reaches a critical value. The explosion can be detected by a fast infrared or ultraviolet detector. The suppression agent is usually injected under pressure within a few milliseconds following detection. Due to the short time involved, it is not practical to send the sensor signal through the data acquisition system. It is actually not necessary since activation of the suppression system is automatic and does not require any computer-like operations on the sensor information. The detector can, however, input sensor status information into the data system. This can provide pilot warning that the system has activated. The suppression system container status can likewise be input to the data system.

Fuel tank explosion suppression systems will be similar. Another possible application of explosion suppression systems are fuel system external vent lines. Several explosion systems and data acquisition system requirements are shown in Figure 13. As previously mentioned, the actual requirements for any particular aircraft will vary widely.

Concentrations of explosive vapors can be detected by vapor detectors and provide early warning of this hazard. Although several types of sensors are available for development into aircraft systems, there are no systems presently available. The many possible types can be categorized into two classes of output signals.

The simplest signal from a vapor detector is a discrete type of signal. Handling of this signal is the same as any other discrete signal. Most likely the vapor detector output signal will be of analog form. On many systems, altitude compensation must also be performed on the signal before vapor concentration can be determined. This type of operation can easily be performed by the central processor, since aircraft altitude is known and a signal proportional to it is available in the aircraft computer. The analog signal would thus need to be input to the data system. The sensor signal very likely would be a millivolt or low level voltage signal. Normal sampling times would be adequate for this sensor signal.

Crew warning would usually only be given if the vapor concentration is above a predetermined threshold level; however, actual vapor concentrations could be displayed if required for certain applications.

e. Cargo Bays

Hazard protection in cargo bays can involve any of the previously discussed fire, explosion, and vapor detectors and any of the extinguishing systems. Typical sensors and signal requirements are illustrated in Figure 13.

An additional type of sensor used in cargo bay applications is a smoke detector which is also known as an early warning fire detector. The signal requirements for this type of detector can vary widely. If the sensor is self-contained, then usually a discrete signal will be input to the data acquisition system. If the actual smoke (particle) concentration is measured and displayed, then an analog signal would be used in the signal transfer. Normal signal sampling would be adequate for this system.

Cargo bays also include special weapons bays on certain aircraft. Although some unique hazards may exist, the discussion of cargo bays will apply in most cases.

f. Wheel Well Compartments

Hazard protection in wheel well compartments may include overheat detectors or fire detectors and an extinguishing system. Typical data system requirements are illustrated in Figure 13.

g. Crew Compartments

Crew compartment hazard protection can involve fire detection, smoke detection, and extinguishing systems. Typical sensor requirements are shown in Figure 13.

h. Required System Capacities

Table 2 summarizes the data system capacities required for a large aircraft. It should be realized that many aircraft will not have hazard protection in all areas discussed. Engine nacelles and APU

compartments will always have some degree of protection. Hazard protection in other areas will depend on the specific system. The information in Table 2 can thus be considered to represent the maximum capability.

TABLE 2
SUMMARY OF LARGE AIRCRAFT HAZARD PROTECTION

LOCATION/TYPE	MULTIPLEX SIGNALS PER LOCATION		NO. OF LOCATIONS	TOTAL	
	INPUT	OUTPUT		INPUT	OUTPUT
ENGINE NACELLE					
6 Dual Optical	12	1	4	48	4
2 Overheat	2	--		8	--
2 Extinguisher	2	2		8	8
AUXILIARY POWER UNIT					
3 Dual Optical	6	1	2	12	2
2 Overheat	2	--		4	--
2 Extinguisher	2	2		4	4
EXPLOSION DETECTION					
Fuel Vents	1	--	2	2	--
Dry Bays	1	--	4	4	--
VAPOR DETECTION	1*	1	10	10*	10
SMOKE DETECTION	1	1	6	6	6
TEMPERATURE SENSOR	1*	1	14	14*	14
			TOTAL	120	48

*May require analog or digital input.

2. SMALL AIRCRAFT (FIGHTER)

Hazard detection in small aircraft such as fighter or close air support is usually limited because of weight and cost considerations. This class of aircraft does not presently have on-board multiplexed data acquisition systems. Future aircraft will, however, incorporate data acquisition systems. Small aircraft will have hazard protection in

engine nacelles and APU compartments. Other aircraft compartments are usually not provided with the active-type systems. A specialized application may occasionally occur. These special requirements will only have minimum impact on a data acquisition system.

An example of a special application is a dry bay adjacent to a fuel tank where fire or explosion detection is required. Other applications such as vapor detection in a gun compartment may exist. Table 3 summarizes the data system capacities required for this vehicle class.

TABLE 3
SUMMARY OF SMALL AIRCRAFT HAZARD PROTECTION

LOCATION/TYPE	MULTIPLEX SIGNALS PER LOCATION		NO. OF LOCATIONS	TOTAL	
	INPUT	OUTPUT		INPUT	OUTPUT
ENGINE NACELLE					
6 Dual Optical	12	1		24	2
2 Overheat	2	--	2	4	--
2 Extinguisher	2	2		4	4
AUXILIARY POWER UNIT					
3 Dual Optical	6	1		6	1
2 Overheat	2	--	1	2	--
2 Extinguisher	2	2		2	2
EXPLOSION DETECTION					
Fuel Vents	1	--	2	2	--
Dry Bays	1	--	2	2	--
VAPOR DETECTION	1*	1	5	5*	5
SMOKE DETECTION	1	1	2	2	2
TEMPERATURE SENSOR	1*	1	8	8*	8
			TOTAL	61	24

*May require analog or digital input.

SECTION VII

LABORATORY BREADBOARD SYSTEM

1. GENERAL DESCRIPTION

A breadboard system was fabricated to demonstrate the techniques used for a multiplexed hazard protection system. The system utilizes an off-the-shelf multiplexed data acquisition system which is known as SOSTEL II (Solid State Electrical Logic). This data system is a second generation system developed for aircraft electrical load switching and control. Several types of sensors were interfaced with the data system. No attempt was made to miniturize the interfacing electronics and several sensors were used with their standard aircraft electronic boxes.

The actual operational characteristics of a future aircraft system will differ from this breadboard system because the data system operational characteristics have changed since the SOSTEL II system was developed. The data system operation has been standardized by MIL-STD-1553A (Reference 12). These changes relate mostly to data word format and transfer characteristics which do not directly influence the hazard protection subsystem operation.

2. HARDWARE

The SOSTEL II data acquisition system components are shown in Figure 14. The system consists of a Central Processor, a Remote Output Terminal, and three Remote Input Terminals. The Central Processor, which is referred to as the Master Unit (MU), contains a programmable memory that is programmed to solve the system logic equations and also to control the system operation. The Remote Output Terminal (ROT) is used to activate hazard suppression devices and to operate the crew display and maintenance display. The Remote Input Terminals (RIT's) are used to input the sensor signals and crew activated signals to the data system. The data system with ground support hardware is shown in Figure 15. The MU memory programmer is located on the left table. The data line diagnostic unit is positioned above the programmer. This device provides a display of data words on the multiplexed data line and is used for

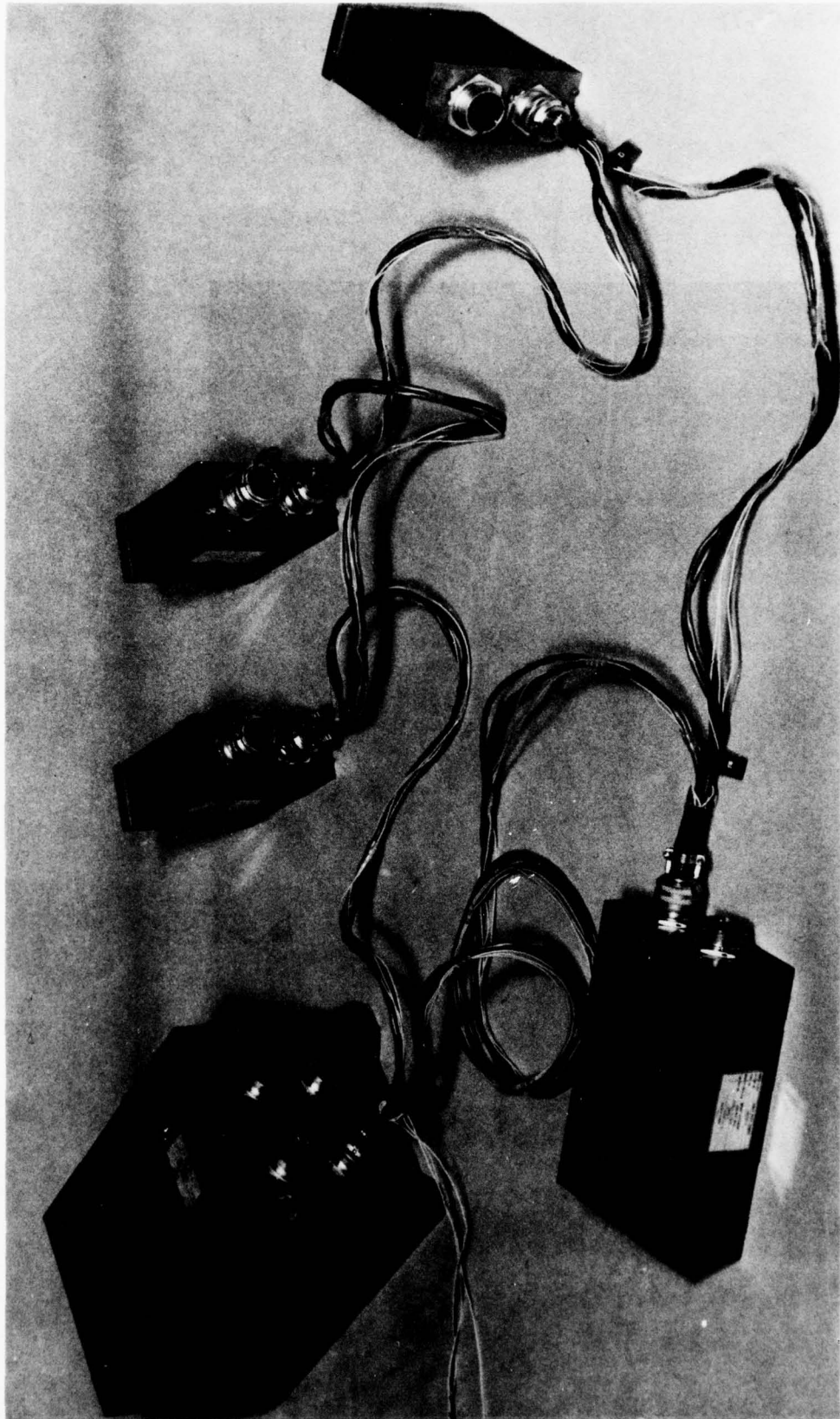

Figure 14. Breadboard System Data Acquisition System (Aircraft Components)

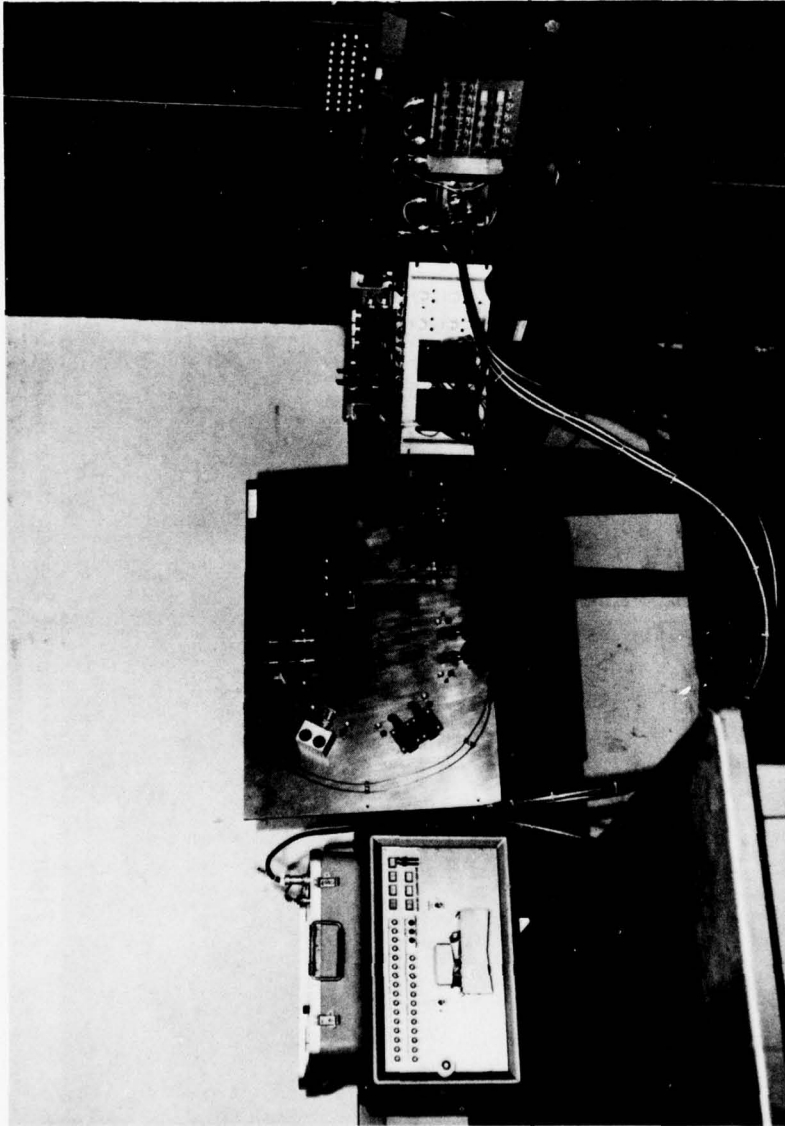

Figure 15. Complete Breadboard Data System

checkout of the system. The hazard sensors are located on the center table. The table on the right contains the sensor electronics, data system, and the display units.

As previously indicated, the engine nacelle application is the most complex in terms of the number of sensors and logic equation solutions. An engine nacelle sensor simulator, which is shown in Figure 16, was used to study the characteristics of redundant sensors and self testing. Actual sensors were later operated with the system as shown in Figure 17. The sensor simulator permits entering either a normal condition, hazard condition, or a failed sensor condition into the data acquisition system for each of the twelve fire detectors and four overheat detectors. In addition, other inputs from the engine nacelle protection system such as the extinguishing system status can be input into the data system with additional switches. The simulator also contains lights which indicate the switch positions (sensor condition).

The logic equations for various types of redundancy were checked by using the sensor simulator. Logic equations such as those used in the integrated system concept (Reference) were studied. The simulator, however, only considers the steady-state conditions and thus does not consider the timing of the signals. Even though the steady-state logic equations are valid, several problems were encountered when the actual sensors were utilized. The most significant problems developed with sensor self-testing delays occur from the time the test signal is activated by the Master Unit until the time the response signal from the sensor electronics is received back at the MU. The delays are caused by signal processing such as signal averaging and pulse counting. These delays will vary with different types of sensors and circuits. These time delays need to be incorporated in the logic equations to allow for the actual delays in the signals. Time delays were difficult to generate with the Master Unit in the SOSTEL II system. Completely successful operation of the system was not obtained in a dynamic self test mode. Occasional random false signals occurred which were most likely caused by timing problems in the processor of the Master Unit. Present day data

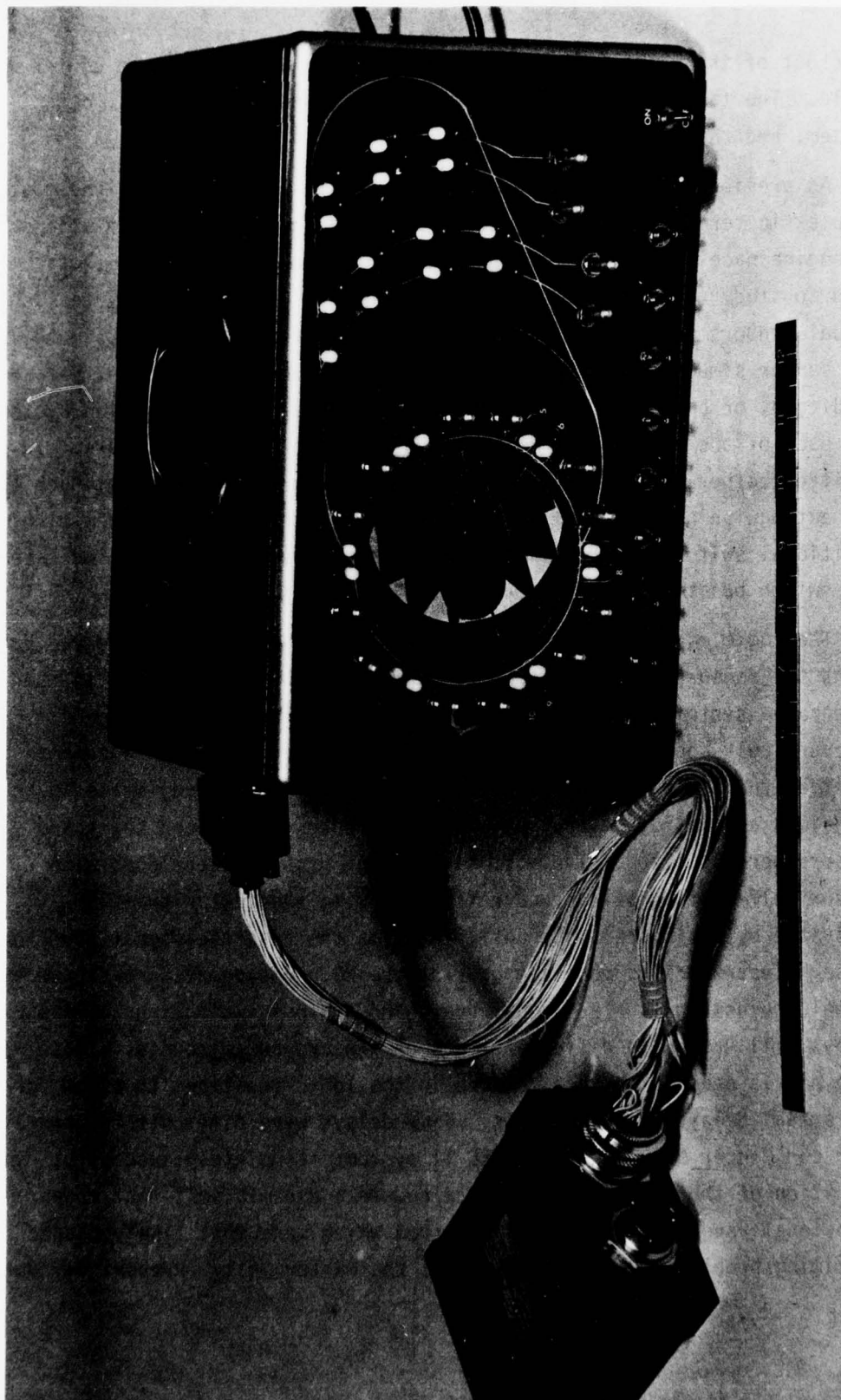

Figure 16. Engine Nacelle Sensor Simulator

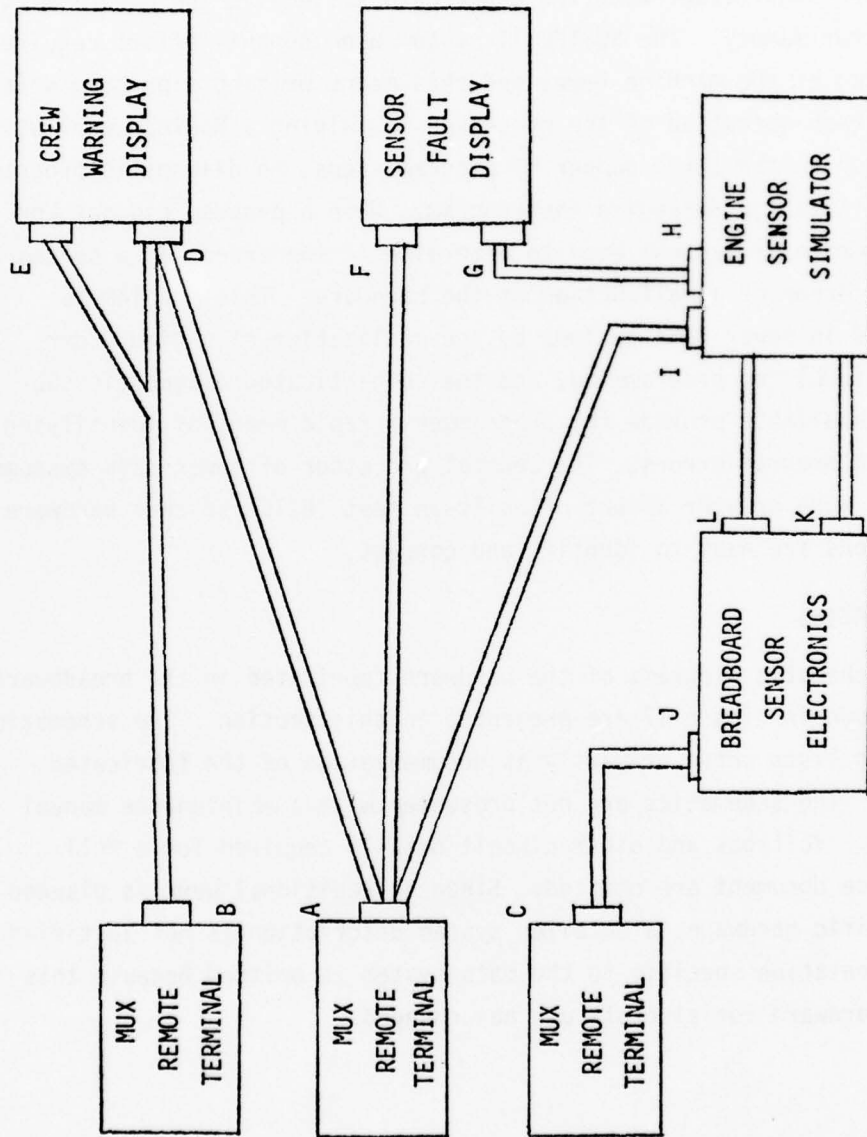

Figure 17. Aircraft Multiplexed Hazard Detection Laboratory Breadboard System

acquisition systems which conform to the MIL-STD-1553A data format can generate time delays and thus this type of problem will not be significant in future systems applications.

Another problem experienced with the SOSTEL II hardware which again will not be significant with the newer data systems is the programming of the computer memory. The SOSTEL II system used on this effort requires programming at the machine level and this means writing a program statement for each operation of the processor in solving a Boolean expression. In addition to the large number of program steps, no diagnostic programs were available for debugging the program. When a program did not correctly operate it was not easy to determine if the error was a software (program) error or a malfunction of the hardware. This problem is eliminated in newer data systems by the utilization of a High Order Language (HOL) for programming, and the sophisticated diagnostic sub-routines available provide the programmer a rapid means of identifying and correcting program errors. The central processor of newer data systems provide a much greater amount of built-in test (BITE) so that hardware malfunctions are easy to identify and correct.

3. SCHEMATICS

The schematic diagrams of the hardware fabricated in the breadboard system shown in Figure 17 are presented in this section. The schematics and wiring lists serve primarily as documentation of the fabricated hardware. The schematics are not presented with a maintenance manual objective. Voltages and other circuit details required for a full maintenance document are omitted. Since no additional work is planned on this specific hardware, a detailed system description is not justified. All documentation specific to the data system is omitted because this type of hardware for aircraft use has changed.

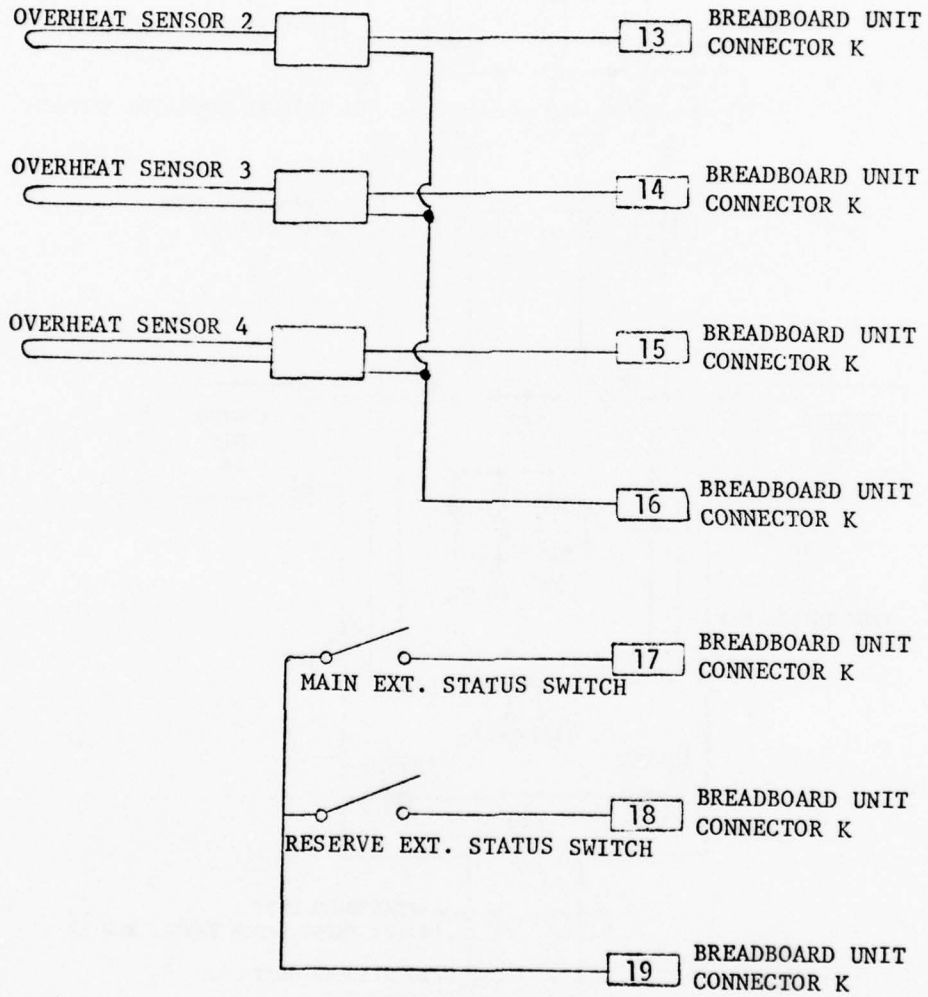

Figure 19. Overheat Sensor Wiring on Engine Simulator

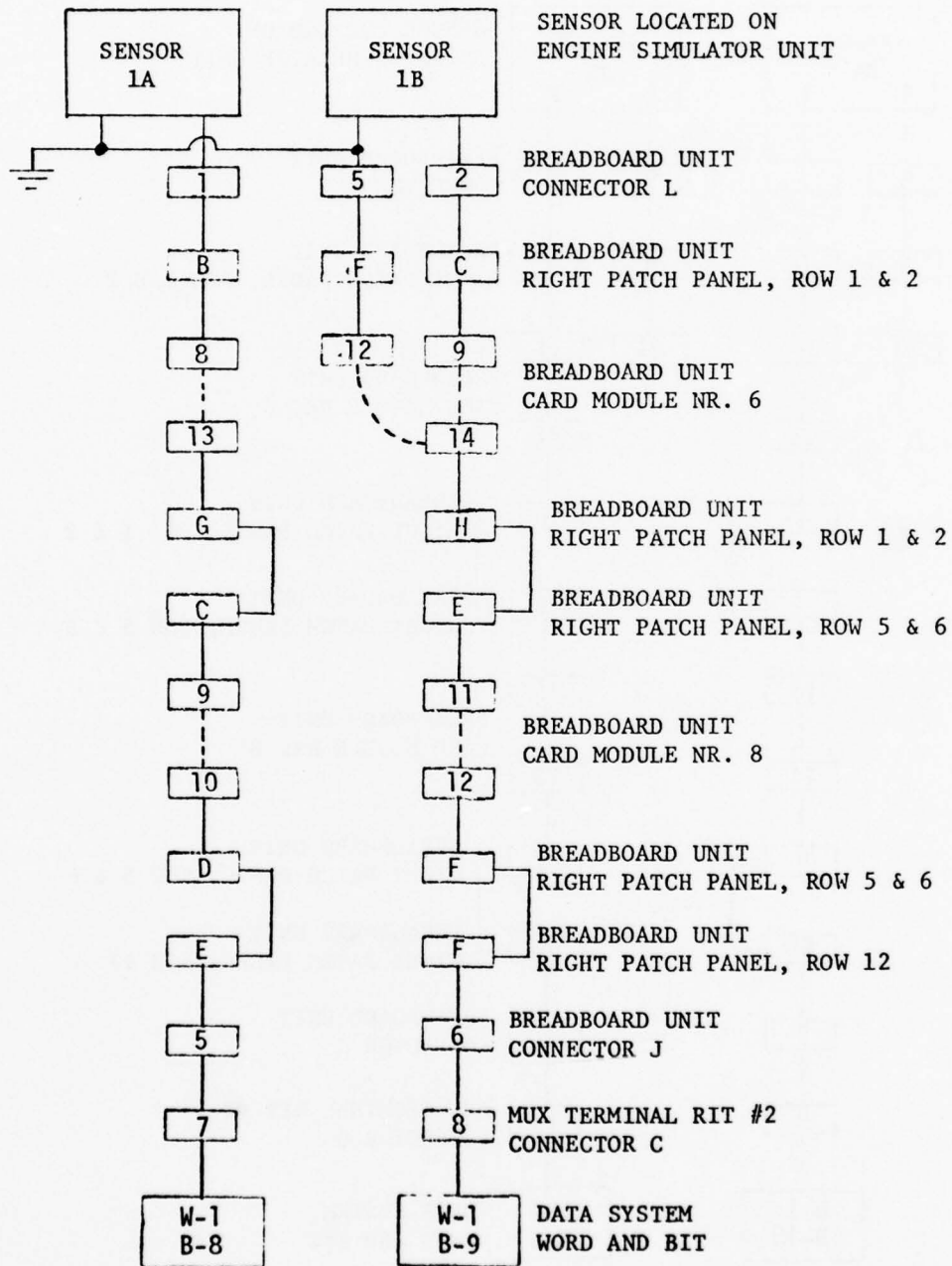

Figure 20. Fire Sensors 1A and 1B Wiring

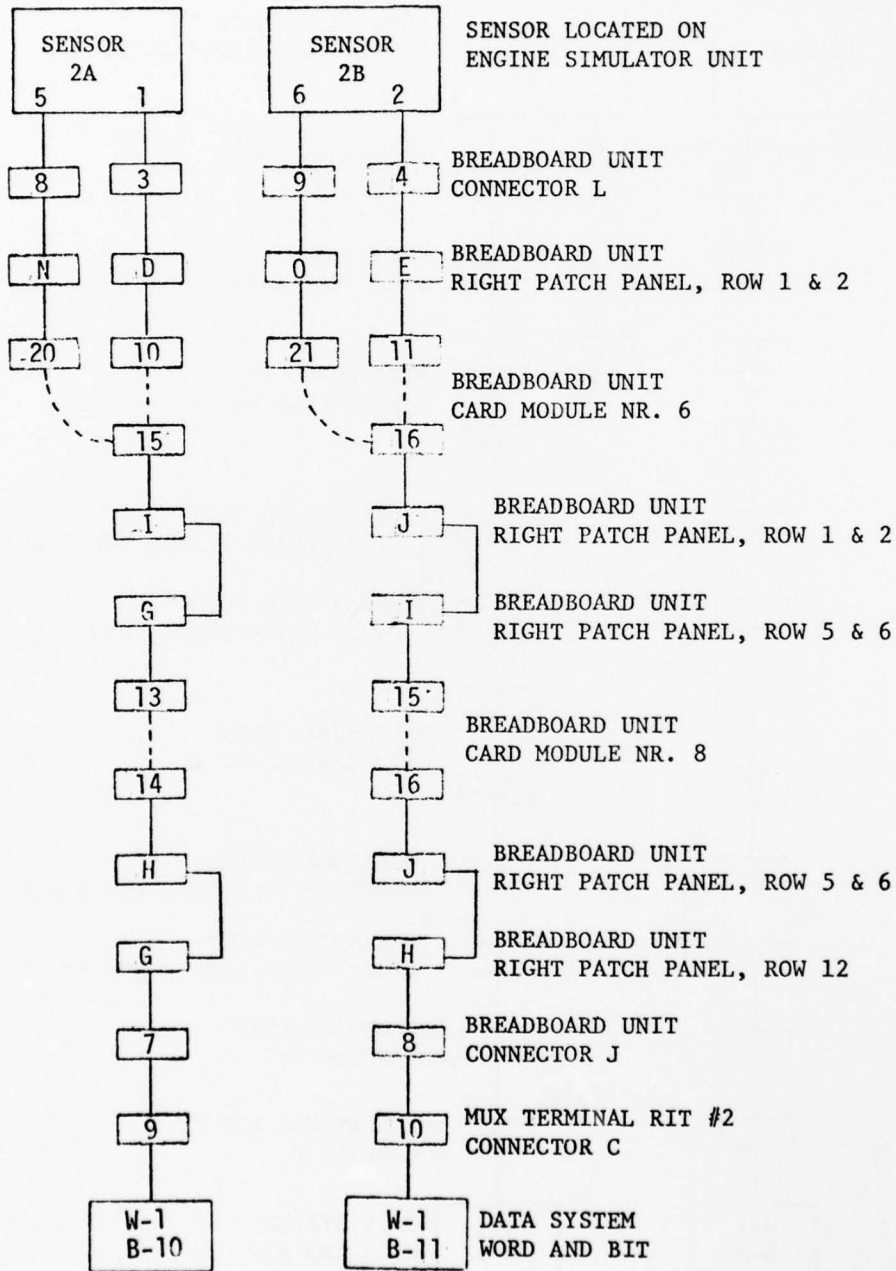

Figure 21. Fire Sensors 2A and 2B Wiring

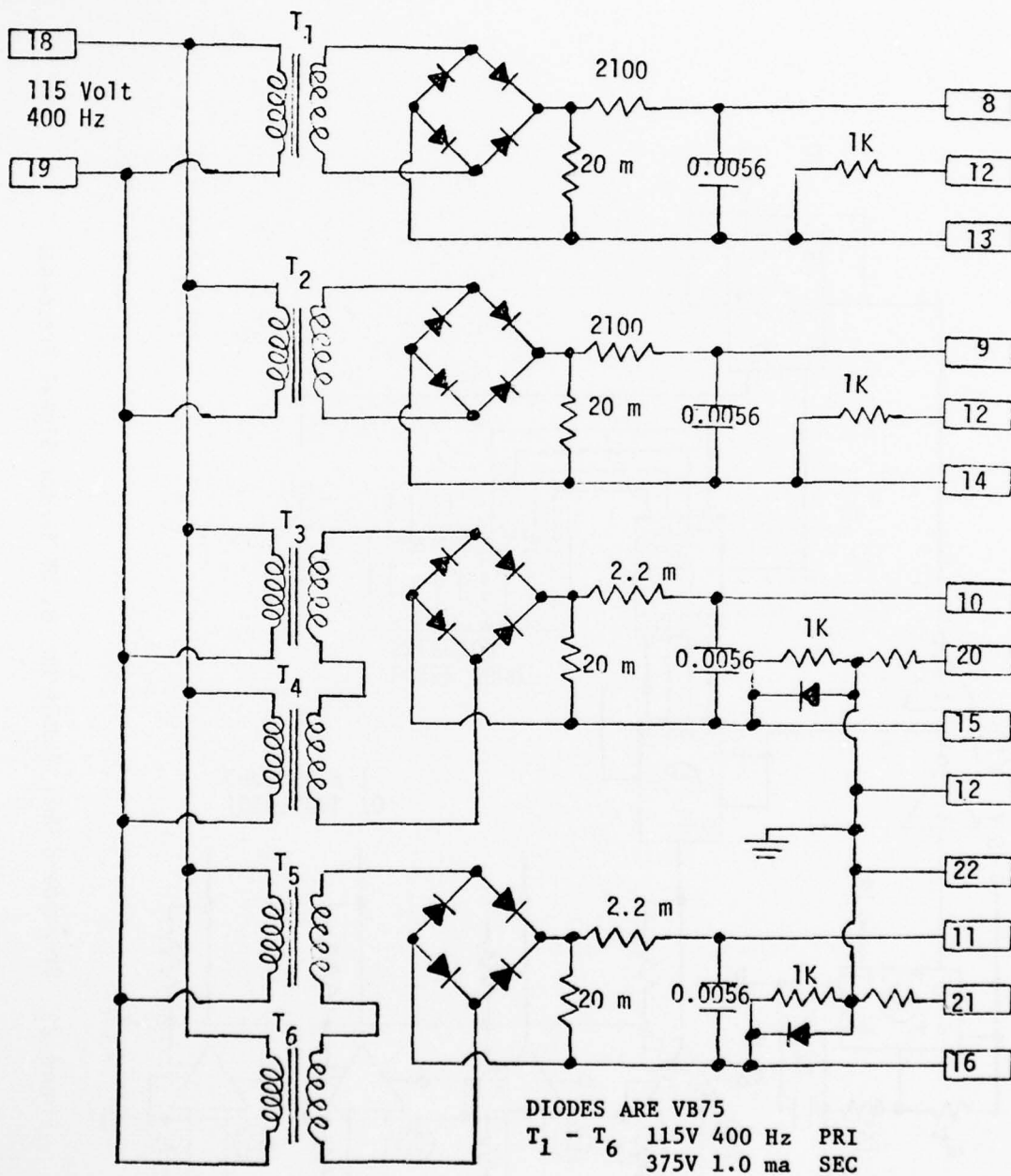

Figure 22. Breadboard Unit Module No. 6, UV Sensor Bias Electronics

FIGURE 23 CONTINUED

INTEGRATED CIRCUIT NOMENCLATURE

<u>I. C. NO.</u>	<u>TYPE</u>
1	NE555V
7	5404
4, 16	5474
5, 11	54193
17, 23	54193
6, 12, 18, 24	LM111D

PULSE COUNT SELECTOR

Jumpers Determine Pulse Count

<u>JUMPER</u>	<u>BCD COUNT</u>
1-16	1
2-15	2
3-14	4
4-13	8
5-12	1
6-11	2
7-10	4
8-9	8

CHANNEL A

CHANNEL B

TIME BASE RESISTOR

$R_t = 3 \text{ meg for } T = 0.5 \text{ sec}$

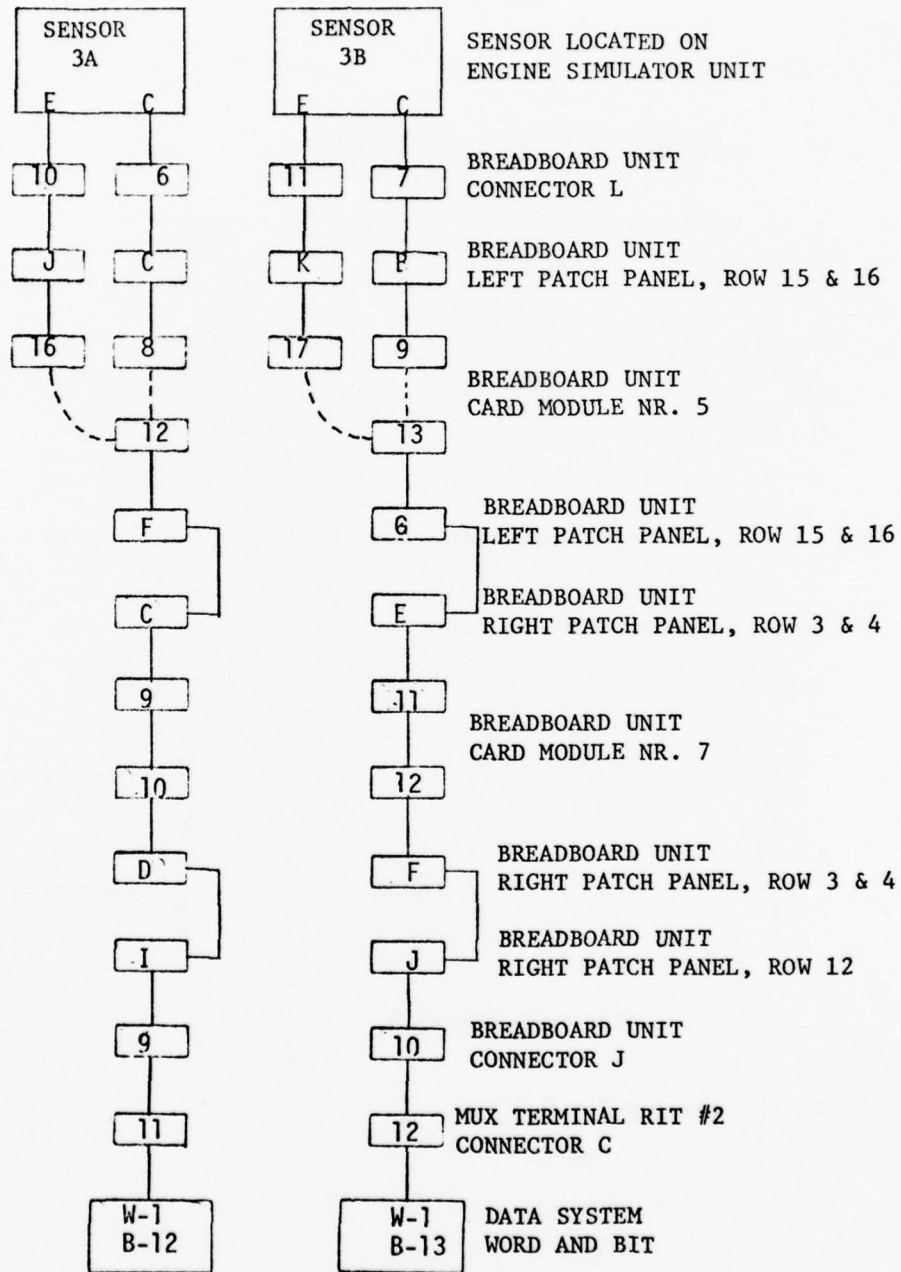

Figure 24. Fire Sensors 3A and 3B Wiring

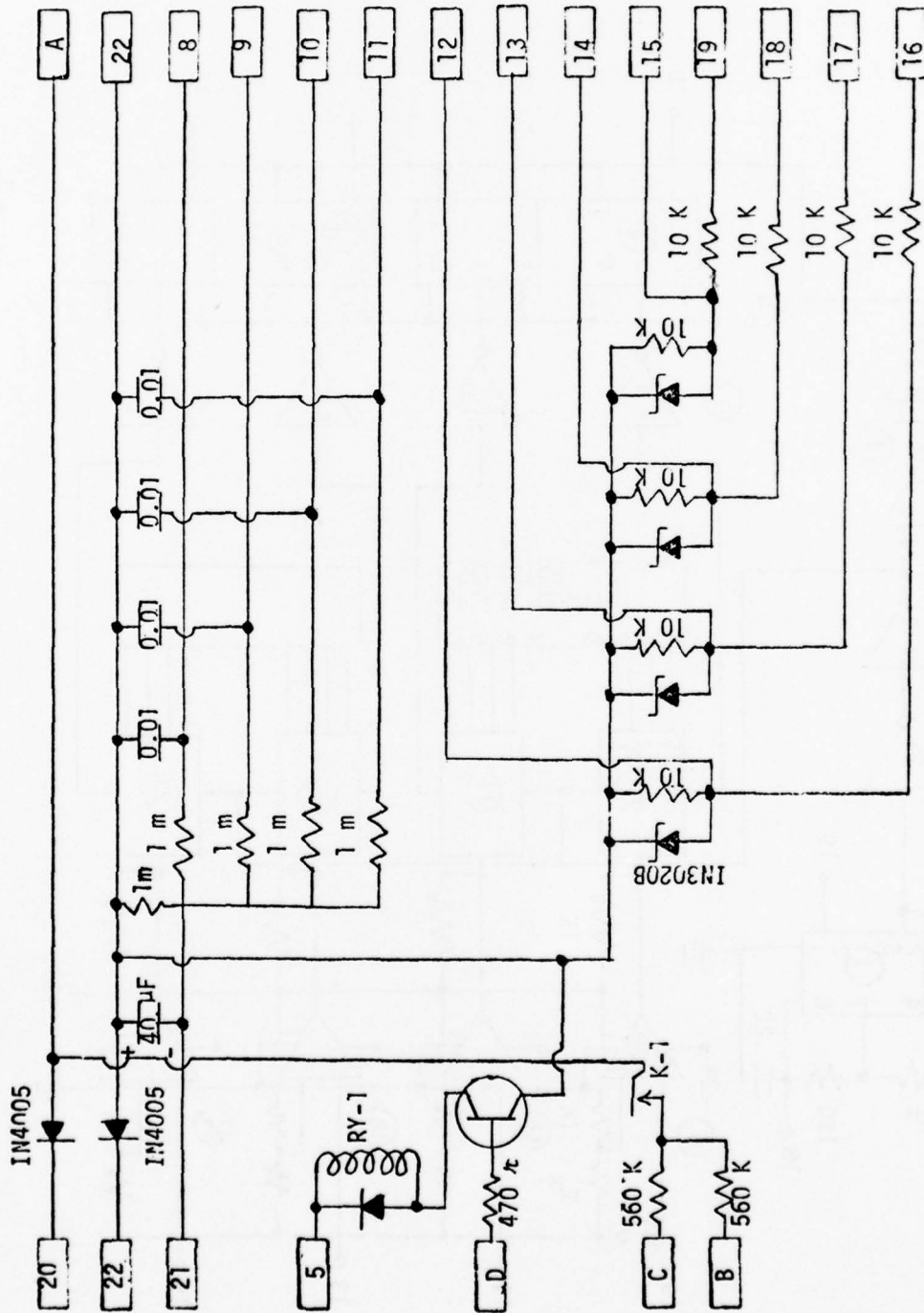

Figure 25. Breadboard Unit Module No. 5, UV Sensor Bias Electronics

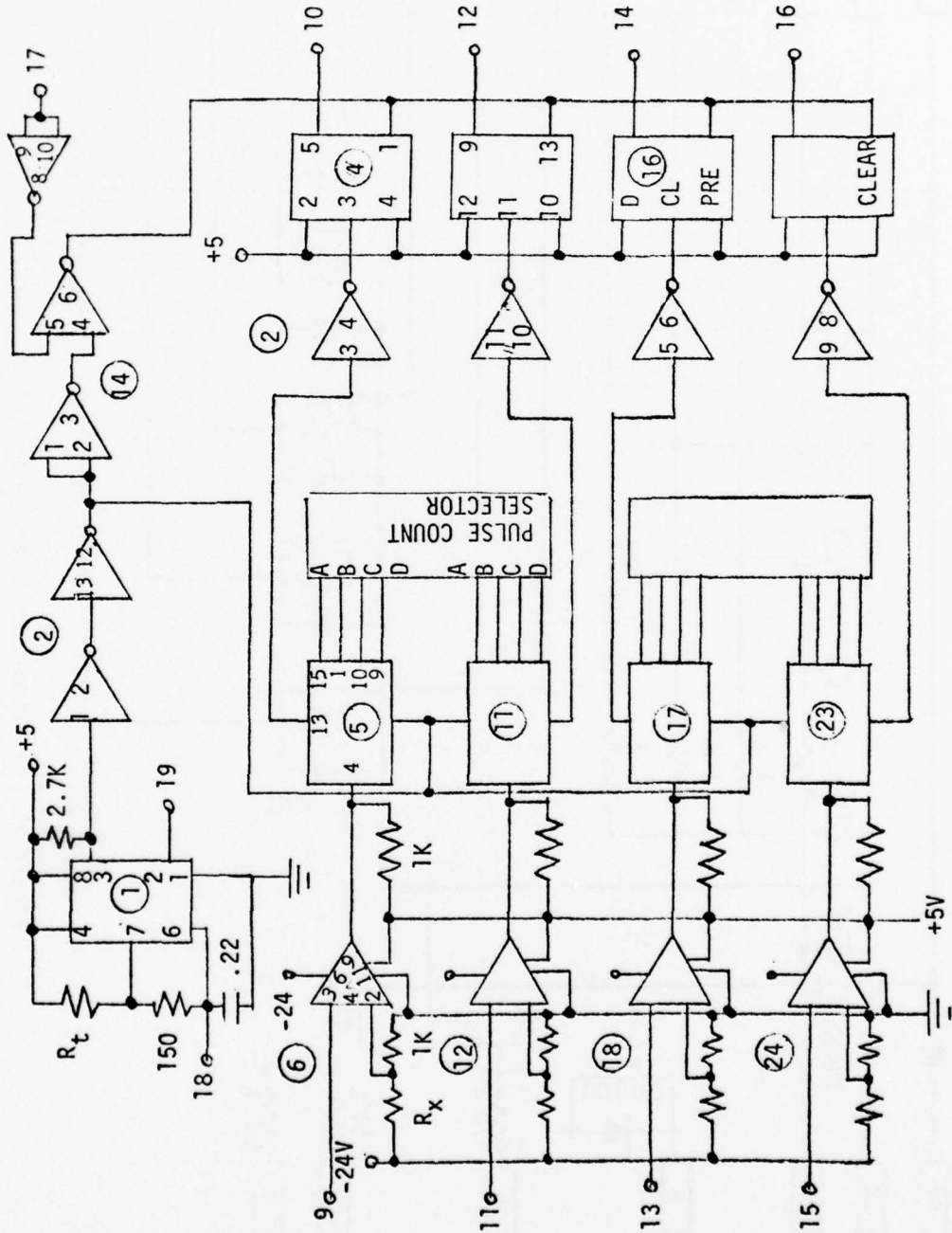

Figure 26. Breadboard Unit Module No. 7, UV Sensor Signal Processor

FIGURE 26 CONTINUED

INTEGRATED CIRCUIT NOMENCLATURE

<u>I. C. NO.</u>	<u>TYPE</u>
1	NE555V
3, 15	5474
4, 10, 16, 22	5485
5, 11, 17, 23	5493
6, 12, 18, 24	LM111D
7	5404

TIME BASE RESISTOR

$R_t = 5 \text{ meg for } T = 0.5 \text{ sec}$

PULSE COUNT SELECTOR

<u>JUMPER</u>	<u>BCD COUNT</u>	
1-16	1	
2-15	2	
3-14	4	CHANNEL A
4-13	8	
5-12	1	
6-11	2	
7-10	4	CHANNEL B
8-9	8	

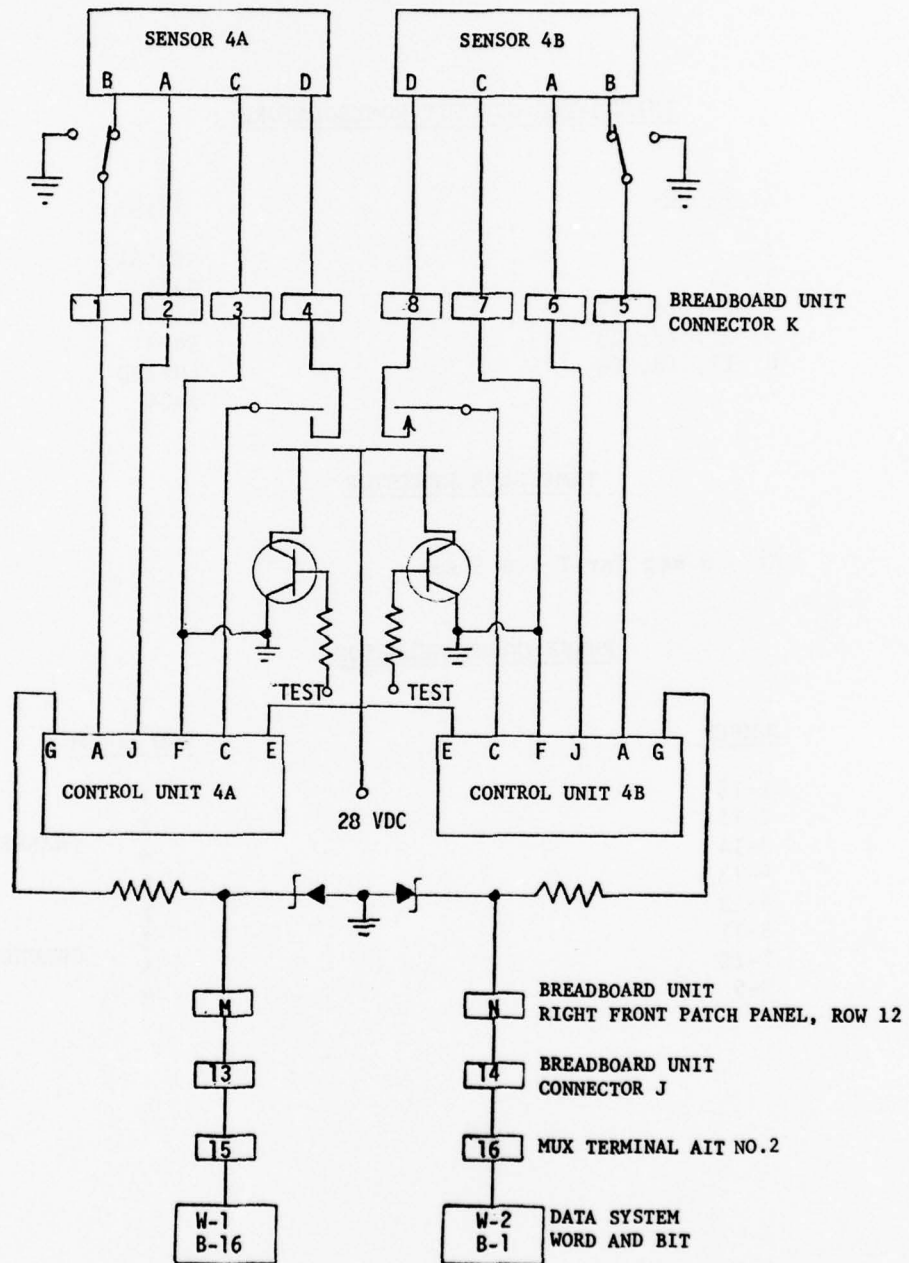

Figure 27. Fire Sensors 4A and 4B Wiring

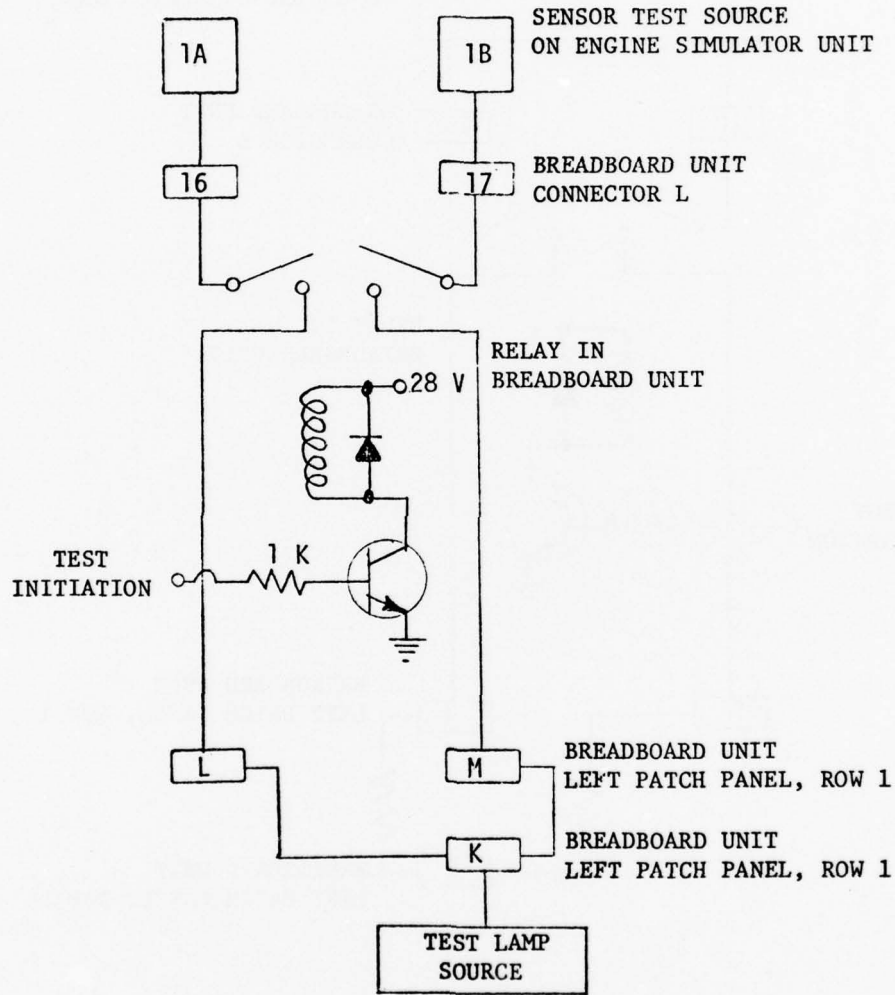

Figure 28. Test Source 1A and 1B Wiring

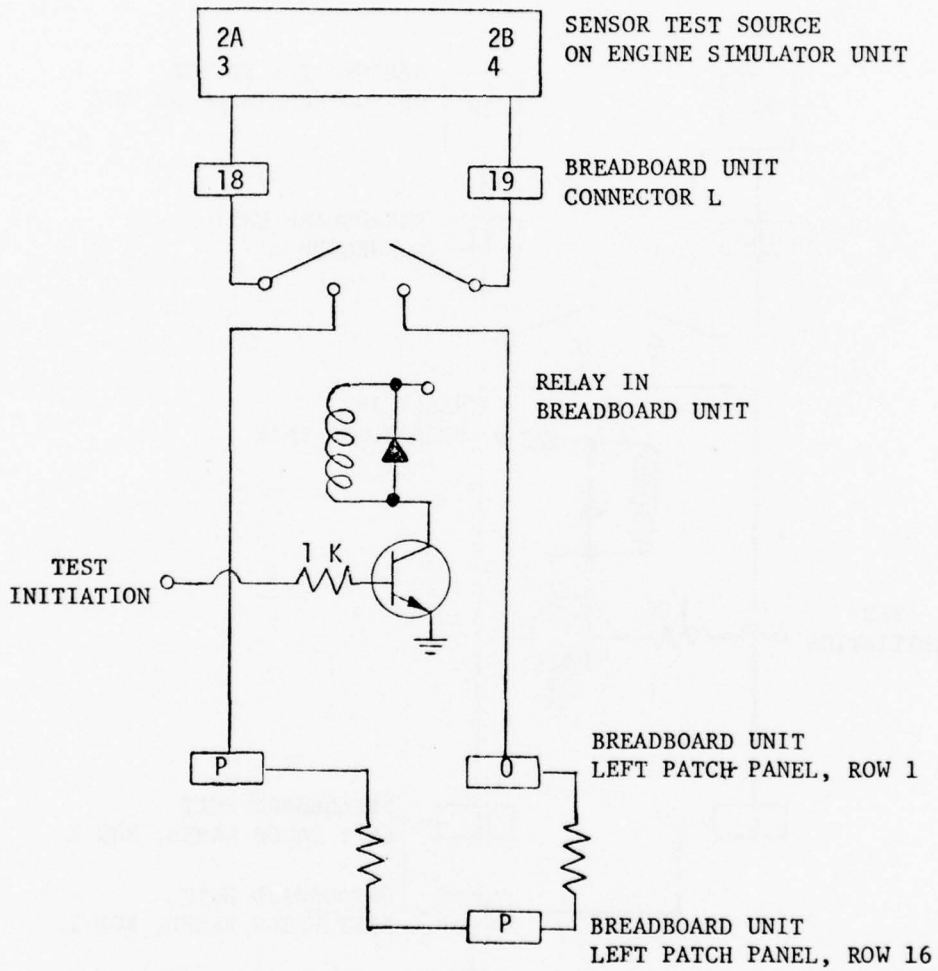

Figure 29. Test Source 2A and 2B Wiring

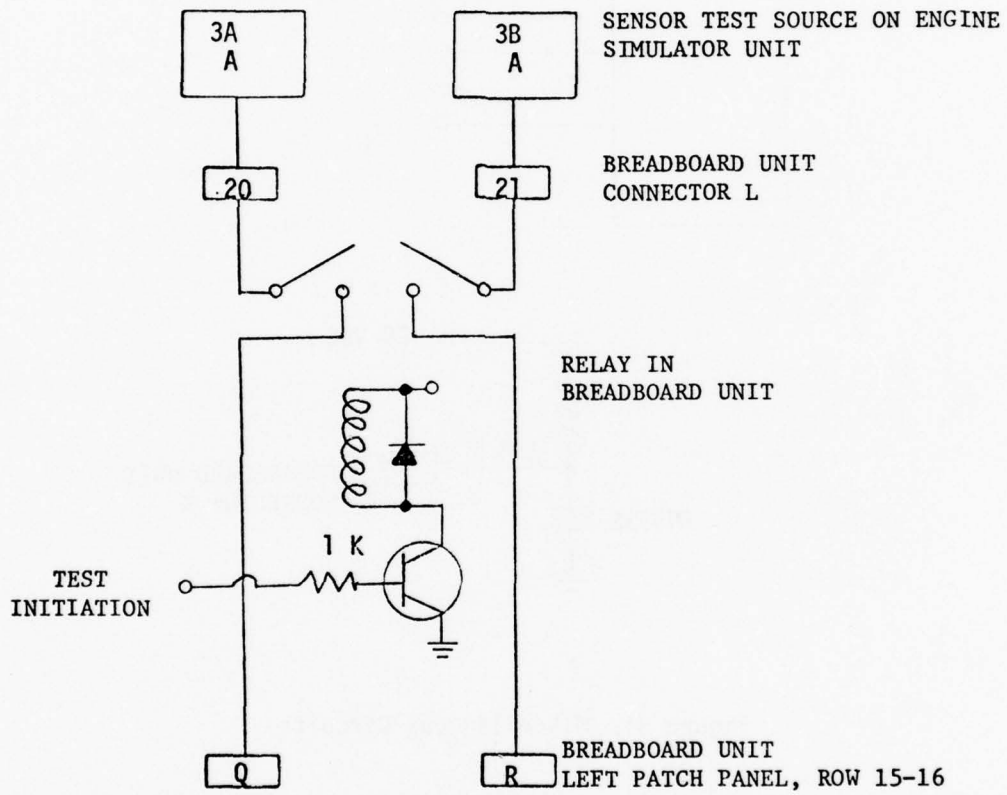

Figure 30. Test Source 3A and 3B Wiring

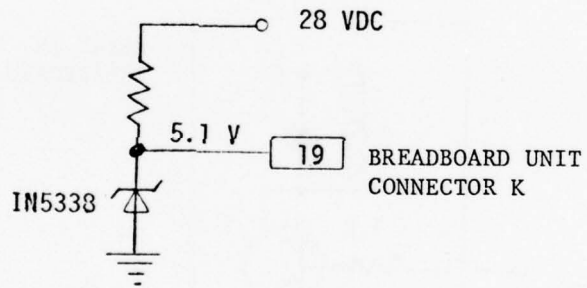
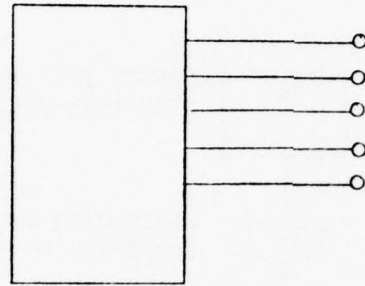
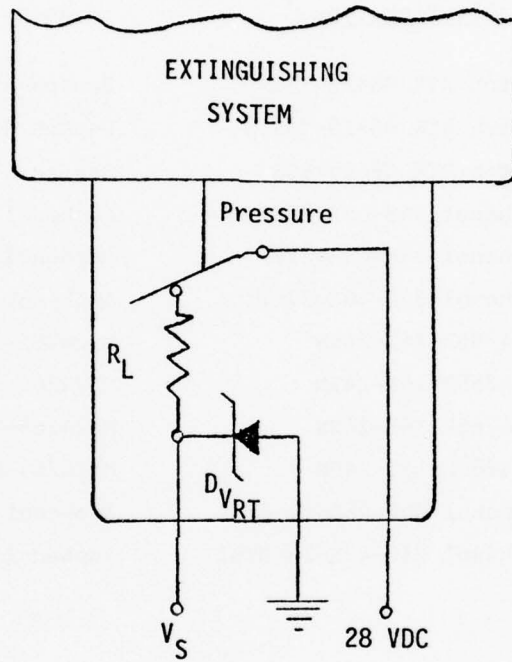

Figure 31. Miscellaneous Circuits



$V_S = V_{RT}$ System Pressurized

$V_S = 0$ System Not Pressurized

$V_{RT} =$ Data System "High" Input Signal

Figure 32. Typical Extinguishing Container Transducer

TABLE 4
CONNECTOR CABLE PLUG AND RECEPTACLE TYPES

<u>Connector</u>	<u>Cable Plug Type</u>	<u>Receptacle</u>
A	Deutch RTK 06-18-85S	Deutch 47012-18-85P
B	Deutch RTK 06-18-85S	Deutch 47012-18-85P
C	Deutch RTK 06-18-85S	Deutch 47012-18-85P
D	Amphenol 348-46E-37S1	Amphenol M81511/01E14-37P1
E	Amphenol 348-46E-37P1	Amphenol M81511/01E14-37S1
F	Amphenol 348-46E-37S1	Amphenol M81511/01E14-38P1
G	MS24266R-16T-24SN	MS24265-R-16T-24P
H	MS24266R-16T-24SN	MS24265-R-16T-24P
I	MS24266R-16T-24SN	MS24265-R-16T-24P
J	MS24266R-16T-24SN	MS24265-R-16T-24P
K	Amphenol 348-46E-14-37S1	Amphenol M81511/01E14-37P1
L	Amphenol 348-46E-14-37S1	Amphenol M81511/01E14-37P1

TABLE 5

WIRING LIST: CONNECTOR A, MULTIPLEX SYSTEM REMOTE OUTPUT TERMINAL

<u>Pin Number</u>	<u>Signal Type and Application</u>
1	Crew Readout: Engine-1 Fire Lamp
2	Crew Readout: Engine-1 Fail Lamp
3	Crew Readout: Engine-1 Primary Ext Lamp
4	Crew Readout: Engine-1 Secondary Ext Lamp
5	Crew Readout: APU-L Fire Lamp
6	Crew Readout: APU-L Fail Lamp
7	Crew Readout: APU-L Primary Ext Lamp
8	Crew Readout: APU-L Secondary Ext Lamp
9	Crew Readout: Forward Avionics Bay Fire Lamp
10	Crew Readout: Forward Avionics Bay Fail Lamp
11	Crew Readout: Forward Avionics Bay Extinguisher Lamp
12	Crew Readout: Engine 1 Overheat Warning Lamp
13	Crew Readout: Engine 1 Overheat Fail Lamp
14	Crew Readout: System in Operation Lamp
15	
16	Engine Simulator: Left Engine Fire Sensor 1A Lamp
17	Engine Simulator: Left Engine Fire Sensor 1B Lamp
18	Engine Simulator: Left Engine Fire Sensor 2A Lamp
19	Engine Simulator: Left Engine Fire Sensor 2B Lamp
20	Engine Simulator: Left Engine Fire Sensor 3A Lamp
21	Engine Simulator: Left Engine Fire Sensor 3B Lamp
22	Engine Simulator: Left Engine Fire Sensor 4A Lamp
23	Engine Simulator: Left Engine Fire Sensor 4B Lamp
24	Engine Simulator: Overheat Sensor 2 Lamp
25	Engine Simulator: Overheat Sensor 3 Lamp
26	Engine Simulator: Overheat Sensor 4 Lamp
27	Breadboard Unit Sensor Test Source Driver
28	Engine Simulator: Left Engine Primary Ext Lamp
29	Engine Simulator: Left Engine Secondary Ext Lamp
30	Engine Simulator: Left Engine Overheat Sensor 1A Lamp
31	Engine Simulator: Left Engine Overheat Sensor 1B Lamp
32	Sensor Fault Indicator: Left Engine Fire Sensor 1A Fail Lamp
33	Sensor Fault Indicator: Left Engine Fire Sensor 1B Fail Lamp
34	Sensor Fault Indicator: Left Engine Fire Sensor 2A Fail Lamp
35	Sensor Fault Indicator: Left Engine Fire Sensor 2B Fail Lamp
36	Sensor Fault Indicator: Left Engine Fire Sensor 3A Fail Lamp
37	Sensor Fault Indicator: Left Engine Fire Sensor 3B Fail Lamp
38	Sensor Fault Indicator: Left Engine Fire Sensor 4A Fail Lamp
39	Sensor Fault Indicator: Left Engine Fire Sensor 4B Fail Lamp
40	Sensor Fault Indicator: Left Engine Fire Sensor 5A Fail Lamp
41	Sensor Fault Indicator: Left Engine Fire Sensor 5B Fail Lamp
42	Sensor Fault Indicator: Left Engine Fire Sensor 6A Fail Lamp
43	Sensor Fault Indicator: Left Engine Fire Sensor 6B Fail Lamp
44	Sensor Fault Indicator: Left Engine Overheat Sensor 1A Fail Lamp
45	Sensor Fault Indicator: Left Engine Overheat Sensor 1B Fail Lamp
46	Sensor Fault Indicator: APU-L Fire Sensor 1A Fail Lamp

TABLE 5 (CONTINUED)

WIRING LIST: CONNECTOR A, MULTIPLEX SYSTEM REMOTE OUTPUT TERMINAL

<u>Pin Number</u>	<u>Signal Type and Application</u>
47	Sensor Fault Indicator: APU-L Fire Sensor 1A Fail Lamp
48	Sensor Fault Indicator: Right Engine Fire Sensor 1A Fail Lamp
49	Sensor Fault Indicator: Right Engine Fire Sensor 1B Fail Lamp
50	Sensor Fault Indicator: Right Engine Fire Sensor 2A Fail Lamp
51	Sensor Fault Indicator: Right Engine Fire Sensor 2B Fail Lamp
52	Sensor Fault Indicator: Right Engine Fire Sensor 3A Fail Lamp
53	Sensor Fault Indicator: Right Engine Fire Sensor 3B Fail Lamp
54	Sensor Fault Indicator: Right Engine Fire Sensor 4A Fail Lamp
55	Sensor Fault Indicator: Right Engine Fire Sensor 4B Fail Lamp
56	Sensor Fault Indicator: Right Engine Fire Sensor 5A Fail Lamp
57	Sensor Fault Indicator: Right Engine Fire Sensor 5B Fail Lamp
58	Sensor Fault Indicator: Right Engine Fire Sensor 6A Fail Lamp
59	Sensor Fault Indicator: Right Engine Fire Sensor 6B Fail Lamp
60	Sensor Fault Indicator: Right Engine Overheat Sensor 1A Fail Lamp
61	Sensor Fault Indicator: Right Engine Overheat Sensor 1B Fail Lamp
62	Sensor Fault Indicator: APU-R Fire Sensor 1A Fail Lamp
63	Sensor Fault Indicator: APU-R Fire Sensor 1B Fail Lamp
64	Mux Bite Input
65	Mux Bite Output
72	Plug Code Input
76	Plug Code Output
80	Sensor Fault Indicator Ground
81	Ground Reference for Engine Simulator

TABLE 6

WIRING LIST: CONNECTOR B, MULTIPLEX SYSTEM REMOTE INPUT TERMINAL NO. 1

<u>Pin Number</u>	<u>Signal Type and Application</u>
1	Engine 1 Primary Extinguisher Switch Input
2	Engine 1 Secondary Extinguisher Switch Input
3	APU-L Primary Extinguisher Switch Input
4	APU-L Secondary Extinguisher Switch Input
5	Forward Avionics Bay Extinguisher Switch Input
6	Engine 2 Primary Extinguisher Switch Input
7	Engine 2 Secondary Extinguisher Switch Input
8	AFT Avionics Bay Extinguisher Switch Input
9	Weapons Bay Primary Extinguisher Switch Input
10	Weapons Bay Secondary Extinguisher Switch Input
11	APU-R Primary Extinguisher Switch Input
12	APU-L Secondary Extinguisher Switch Input
13	Engine 3 Primary Extinguisher Switch Input
14	
	Not Used
63	
64	Mux Bite Input
65	Mux Bite Output
72	Plug Code Input
76	Plug Code Output
77	Crew Readout Signal Ground (Reference)

TABLE 7
WIRING LIST: CONNECTOR D, CREW READOUT

<u>Pin Number</u>	<u>Signal Type</u>	<u>Readout Designation</u>
1	Lamp	Engine-1, Fire
2	Lamp	Engine-1, Fail
3	Lamp	Engine-1, Exting & P
4	Lamp	Engine 1, S
5	Lamp	APU-L, Fire
6	Lamp	APU-L, Fail
7	Lamp	APU-L, Exting & P
8	Lamp	APU-L, S
9	Lamp	AV-FWD, Fire
10	Lamp	AV-FWD, Fail
11	Lamp	AV-FWD, Exting & Disc
12	Lamp	Engine-1, OHEAT
13	Lamp	Engine-1, OHEAT Fail
14	Lamp	System in Operation
15	Ground	
16	Ground	
17	28 Volt DC	Input Power
18	Ground	
19	Switch	Engine-1, P
20	Switch	Engine-1, S
21	Switch	APU-L, P
22	Switch	APU-L, S
23	Switch	AV-FWD, EXT ACT
24	Switch	Engine-2, P
25	Switch	Engine-2, S
26	Switch	AV-AFT, EXT ACT
27	Switch	WPN-1, P
28	Switch	WPN-1, S
29	Switch	APU-R, P
30	Switch	APU-R, S
31	Switch	Engine-3, P
32	Switch	Engine-3, S
33	Switch	Engine-4, P
34	Switch	Engine-4, S
35	Lamp	Engine-2, Fire
36	Lamp	Engine-2, Fail
37	Lamp	Engine-2, Exting & P

TABLE 8
WIRING LIST: CONNECTOR E, CREW READOUT

<u>Pin Number</u>	<u>Signal Type</u>	<u>Readout Designation</u>
1	Lamp	Engine-2, S
2	Lamp	APU-R, Fire
3	Lamp	APU-R, Fail
4	Lamp	APU-R, Exting & P
5	Lamp	APU-R, S
6	Lamp	Engine-3, Fire
7	Lamp	Engine-3, Fail
8	Lamp	Engine-3, Exting & P
9	Lamp	Engine-3, S
10	Lamp	Engine-4, Fire
11	Lamp	Engine-4, Fail
12	Lamp	Engine-4, Exting & P
13	Lamp	Engine-4, S
14	Lamp	AV-AFT, Fire
15	Lamp	AV-AFT, Fail
16	Lamp	AV-AFT, Exting & Disc
17	Lamp	WPN-1, Fire
18	Lamp	WPN-1, Fail
19	Lamp	WPN-1, Exting & P
20	Lamp	WPN-1, S
21	Lamp	WPN-2, Fire
22	Lamp	WPN-2, Fail
23	Lamp	WPN-2, Exting & P
24	Lamp	WPN-2, S

TABLE 9

WIRING LIST: CONNECTOR F, SENSOR FAULT INDICATOR UNIT

<u>Pin Number</u>	<u>Signal Type and Application</u>
1	Engine 1 Fire Sensor 1A Fail Signal Input
2	Engine 1 Fire Sensor 1B Fail Signal Input
3	Engine 1 Fire Sensor 2A Fail Signal Input
4	Engine 1 Fire Sensor 2B Fail Signal Input
5	Engine 1 Fire Sensor 3A Fail Signal Input
6	Engine 1 Fire Sensor 3B Fail Signal Input
7	Engine 1 Fire Sensor 4A Fail Signal Input
8	Engine 1 Fire Sensor 4B Fail Signal Input
9	Engine 1 Fire Sensor 5A Fail Signal Input
10	Engine 1 Fire Sensor 5B Fail Signal Input
11	Engine 1 Fire Sensor 6A Fail Signal Input
12	Engine 1 Fire Sensor 6B Fail Signal Input
13	Engine 1 Overheat Sensor 1A Fail Signal Input
14	Engine 1 Overheat Sensor 1B Fail S
15	APU-L Fire Sensor 1A Fail Signal Input
16	APU-L Fire Sensor 1B Fail Signal Input
17	Engine 2 Fire Sensor 1A Fail Signal Input
18	Engine 2 Fire Sensor 1B Fail Signal Input
19	Engine 2 Fire Sensor 2A Fail Signal Input
20	Engine 2 Fire Sensor 2B Fail Signal Input
21	Engine 2 Fire Sensor 3A Fail Signal Input
22	Engine 2 Fire Sensor 3B Fail Signal Input
23	Engine 2 Fire Sensor 4A Fail Signal Input
24	Engine 2 Fire Sensor 4B Fail Signal Input
25	Engine 2 Fire Sensor 5A Fail Signal Input
26	Engine 2 Fire Sensor 5B Fail Signal Input
27	Engine 2 Fire Sensor 6A Fail Signal Input
28	Engine 2 Fire Sensor 6B Fail Signal Input
29	Engine 2 Overheat Sensor 1A Fail Signal Input
30	Engine 2 Overheat Sensor 1B Fail Signal Input
31	APU-R Fire Sensor 1A Fail Signal Input
32	APU-R Fire Sensor 1B Fail Signal Input
33	Signal Ground (Mux Reference)
34	Power Ground (28 Volt Line)
35	28 Volt DC Power Input
36	Not Used
37	Not Used

TABLE 10

WIRING LIST: CONNECTOR G, MAINTENANCE WARNING UNIT

<u>Pin Number</u>	<u>Signal Type and Application</u>
1	Engine 1 Fire Sensor 1A Fail Signal Output
2	Engine 1 Fire Sensor 1B Fail Signal Output
3	Engine 1 Fire Sensor 2A Fail Signal Output
4	Engine 1 Fire Sensor 2B Fail Signal Output
5	Engine 1 Fire Sensor 3A Fail Signal Output
6	Engine 1 Fire Sensor 3B Fail Signal Output
7	Engine 1 Fire Sensor 4A Fail Signal Output
8	Engine 1 Fire Sensor 4B Fail Signal Output
9	Engine 1 Fire Sensor 5A Fail Signal Output
10	Engine 1 Fire Sensor 5B Fail Signal Output
11	Engine 1 Fire Sensor 6A Fail Signal Output
12	Engine 1 Fire Sensor 6B Fail Signal Output
13	Engine 1 Overheat Sensor 1A Fail Signal Output
14	Engine 1 Overheat Sensor 1B Fail Signal Output
15	APU-L Fire Sensor 1A Fail Signal Output
16	APU-L Fire Sensor 1B Fail Signal Output
17	Engine 2 Fire Sensor 1A Fail Signal Output
18	Engine 2 Fire Sensor 1B Fail Signal Output
19	Engine 2 Fire Sensor 2A Fail Signal Output
20	Engine 2 Fire Sensor 2B Fail Signal Output
21	Engine 2 Fire Sensor 3A Fail Signal Output
22	Engine 2 Fire Sensor 3B Fail Signal Output
23	Engine 2 Fire Sensor 4A Fail Signal Output
24	Engine 2 Fire Sensor 4B Fail Signal Output

TABLE 11

WIRING LIST: CONNECTOR H, ENGINE SIMULATOR UNIT

<u>Pin Number</u>	<u>Signal Type and Application</u>
1	Engine 1 Fire Sensor 1A Fail Signal Input
2	Engine 1 Fire Sensor 1B Fail Signal Input
3	Engine 1 Fire Sensor 2A Fail Signal Input
4	Engine 1 Fire Sensor 2B Fail Signal Input
5	Engine 1 Fire Sensor 3A Fail Signal Input
6	Engine 1 Fire Sensor 3B Fail Signal Input
7	Engine 1 Fire Sensor 4A Fail Signal Input
8	Engine 1 Fire Sensor 4B Fail Signal Input
9	Engine 1 Fire Sensor 5A Fail Signal Input
10	Engine 1 Fire Sensor 5B Fail Signal Input
11	Engine 1 Fire Sensor 6A Fail Signal Input
12	Engine 1 Fire Sensor 6B Fail Signal Input
13	Engine 1 Overheat Sensor 1A Fail Signal Input
14	Engine 1 Overheat Sensor 1B Fail Signal Input
15	APU-L Fire Sensor 1A Fail Signal Input
16	APU-L Fire Sensor 1B Fail Signal Input
17	Engine 2 Fire Sensor 1A Fail Signal Input
18	Engine 2 Fire Sensor 1B Fail Signal Input
19	Engine 2 Fire Sensor 2A Fail Signal Input
20	Engine 2 Fire Sensor 2B Fail Signal Input
21	Engine 2 Fire Sensor 3A Fail Signal Input
22	Engine 2 Fire Sensor 3B Fail Signal Input
23	Engine 2 Fire Sensor 4A Fail Signal Input
24	Engine 2 Fire Sensor 4B Fail Signal Input

TABLE 12

WIRING LIST: CONNECTOR I, ENGINE SIMULATOR UNIT

<u>Pin Number</u>	<u>Signal Type and Application</u>
1	Left Engine Fire Sensor 1A Lamp
2	Left Engine Fire Sensor 1B Lamp
3	Left Engine Fire Sensor 2A Lamp
4	Left Engine Fire Sensor 2B Lamp
5	Left Engine Fire Sensor 3A Lamp
6	Left Engine Fire Sensor 3B Lamp
7	Left Engine Fire Sensor 4A Lamp
8	Left Engine Fire Sensor 4B Lamp
9	Left Engine Overheat Sensor 2 Lamp
10	Left Engine Overheat Sensor 3 Lamp
11	Left Engine Overheat Sensor 4 Lamp
12	Not Used
13	Left Engine Primary Extinguisher Lamp
14	Left Engine Secondary Extinguisher Lamp
15	Left Engine Overheat Sensor 1A Lamp
16	Left Engine Overheat Sensor 1B Lamp
17	Ground Reference for Mux Terminal
18	28 Volt Lamp Power Input

TABLE 13

WIRING LIST: CONNECTOR J, SENSOR BREADBOARD ELECTRONIC UNIT

<u>Pin Number</u>	<u>Signal Type and Application</u>
1	Breadboard Power On Reference
2	Breadboard Electronics: Sensor Test Source Signal τ_2
3	Breadboard Electronics: Sensor Test Source Signal τ_3
4	Breadboard Electronics: Sensor Test Source Signal τ_4
5	Breadboard Electronics: Engine 1 Fire Sensor 1A Signal
6	Breadboard Electronics: Engine 1 Fire Sensor 1B Signal
7	Breadboard Electronics: Engine 1 Fire Sensor 2A Signal
8	Breadboard Electronics: Engine 1 Fire Sensor 2B Signal
9	Breadboard Electronics: Engine 1 Fire Sensor 3A Signal
10	Breadboard Electronics: Engine 1 Fire Sensor 3B Signal
11	Breadboard Electronics: Sensor Test Source Signal τ_1
12	Breadboard Electronics: Sensor Test Source Signal τ_5
13	Breadboard Electronics: Engine 1 Fire Sensor 4A Signal
14	Breadboard Electronics: Engine 1 Fire Sensor 4B Signal
15	Breadboard Electronics: Engine 1 Overheat Sensor 1A Signal
16	Breadboard Electronics: Engine 1 Overheat Sensor 1B Signal
17	Breadboard Electronics: Engine 1 Overheat Sensor 2 Signal
18	Breadboard Electronics: Engine 1 Overheat Sensor 3 Signal
19	Breadboard Electronics: Engine 1 Overheat Sensor 4 Signal
20	Breadboard Electronics: Engine 1 Primary Extinguisher Status Signal
21	Breadboard Electronics: Engine 1 Secondary Extinguisher Status Signal
22	Breadboard Electronics: Sensor Test Source Signal τ_6
23	Not Used
24	Breadboard Electronics: Signal Ground (Reference)

TABLE 14

WIRING LIST: CONNECTOR L, BREADBOARD SENSOR ELECTRONIC UNIT

<u>Pin Number</u>	<u>Signal Type and Application</u>
1	Engine Simulator Sensor 1A Signal
2	Engine Simulator Sensor 1B Signal
3	Engine Simulator Sensor 2A Signal
4	Engine Simulator Sensor 2B Signal
5	Engine Simulator Sensor 1A, 1B, 2A, 2B Ground
6	Engine Simulator Sensor 3A Supply
7	Engine Simulator Sensor 3B Supply
8	Not Used
9	Not Used
10	Engine Simulator Sensor 3A Signal
11	Engine Simulator Sensor 3B Signal
12	Not Used
13	Not Used
14	Not Used
15	Not Used
16	Engine Simulator Sensor 1A Test Source Signal
17	Engine Simulator Sensor 1B Test Source Signal
18	Engine Simulator Sensor 2A Test Source Signal
19	Engine Simulator Sensor 2B Test Source Signal
20	Engine Simulator Sensor 3A Test Source Signal
21	Engine Simulator Sensor 3B Test Source Signal

TABLE 15

WIRING LIST: CONNECTOR K, BREADBOARD SENSOR ELECTRONIC UNIT

<u>Pin Number</u>	<u>Signal Type and Application</u>
1	Engine Simulator Sensor 4A Signal
2	Engine Simulator Sensor 4A Signal
3	Engine Simulator Sensor 4A Test Source Ground
4	Engine Simulator Sensor 4A Test Source Supply
5	Engine Simulator Sensor 4B Signal
6	Engine Simulator Sensor 4B Signal
7	Engine Simulator Sensor 4B Test Source Ground
8	Engine Simulator Sensor 4B Test Source Supply
9	Engine Simulator Overheat Sensor 1A Signal
10	Engine Simulator Overheat Sensor 1A Signal
11	Engine Simulator Overheat Sensor 1B Signal
12	Engine Simulator Overheat Sensor 1B Signal
13	Engine Simulator Overheat Sensor 2 Signal
14	Engine Simulator Overheat Sensor 3 Signal
15	Engine Simulator Overheat Sensor 4 Signal
16	Engine Simulator Sensor Ground
17	Engine Simulator Main Extinguisher Status Signal
18	Engine Simulator Reserve Extinguisher Status Signal
19	Engine Simulator 5 Volt Reference Supply

TABLE 16

WIRING LIST: INTERCONNECTION BETWEEN CONNECTORS A, D, F, AND I

<u>Connector A Pin Number</u>	To	<u>Connector X - Pin XX</u>
A - Pin 1		D - Pin 1
A - Pin 2		D - Pin 2
A - Pin 3		D - Pin 3
A - Pin 4		D - Pin 4
A - Pin 5		D - Pin 5
A - Pin 6		D - Pin 6
A - Pin 7		D - Pin 7
A - Pin 8		D - Pin 8
A - Pin 9		D - Pin 9
A - Pin 10		D - Pin 10
A - Pin 11		D - Pin 11
A - Pin 12		D - Pin 12
A - Pin 13		D - Pin 13
A - Pin 14		D - Pin 14
A - Pin 15		D - Pin 15
A - Pin 16		I - Pin 1
A - Pin 17		I - Pin 2
A - Pin 18		I - Pin 3
A - Pin 19		I - Pin 4
A - Pin 20		I - Pin 5
A - Pin 21		I - Pin 6
A - Pin 22		I - Pin 7
A - Pin 23		I - Pin 8
A - Pin 24		I - Pin 9
A - Pin 25		I - Pin 10
A - Pin 26		I - Pin 11
A - Pin 27		Breadboard Unit Sensor Test
A - Pin 28		I - Pin 13
A - Pin 29		I - Pin 14
A - Pin 30		I - Pin 15
A - Pin 31		I - Pin 16
A - Pin 32		F - Pin 1
A - Pin 33		F - Pin 2
A - Pin 34		F - Pin 3
A - Pin 35		F - Pin 4
A - Pin 36		F - Pin 5
A - Pin 37		F - Pin 6
A - Pin 38		F - Pin 7
A - Pin 39		F - Pin 8
A - Pin 40		F - Pin 9
A - Pin 41		F - Pin 10
A - Pin 42		F - Pin 11
A - Pin 43		F - Pin 12
A - Pin 44		F - Pin 13
A - Pin 45		F - Pin 14

TABLE 17

WIRING LIST: INTERCONNECTION BETWEEN CONNECTORS A, D, F, AND I - (CONTINUED)

<u>Connector A Pin Number</u>	<u>To</u>	<u>Connector X - Pin XX</u>
A - Pin 46		F - Pin 15
A - Pin 47		F - Pin 16
A - Pin 48		F - Pin 17
A - Pin 49		F - Pin 18
A - Pin 50		F - Pin 19
A - Pin 51		F - Pin 20
A - Pin 52		F - Pin 21
A - Pin 53		F - Pin 22
A - Pin 54		F - Pin 23
A - Pin 55		F - Pin 24
A - Pin 56		F - Pin 25
A - Pin 57		F - Pin 26
A - Pin 58		F - Pin 27
A - Pin 59		F - Pin 28
A - Pin 60		F - Pin 29
A - Pin 61		F - Pin 30
A - Pin 62		F - Pin 31
A - Pin 63		F - Pin 32
A - Pin 64		A - Pin 65
A - Pin 65		A - Pin 64
A - Pin 66		
	Not Used	
A - Pin 71		
A - Pin 72		A - Pin 76
A - Pin 73		
A - Pin 74	Not Used	
A - Pin 75		
A - Pin 76		A - Pin 72
A - Pin 77		
A - Pin 78	Not Used	
A - Pin 79		
A - Pin 80		F - Pin 33
A - Pin 81		I - Pin 17

TABLE 18

WIRING LIST: INTERCONNECTION BETWEEN CONNECTORS C AND J

<u>Connector C Pin Number</u>	To	<u>Connector X - Pin XX</u>
C - Pin 3		J - Pin 1
C - Pin 4		J - Pin 2
C - Pin 5		J - Pin 3
C - Pin 6		J - Pin 4
C - Pin 7		J - Pin 5
C - Pin 8		J - Pin 6
C - Pin 9		J - Pin 7
C - Pin 10		J - Pin 8
C - Pin 11		J - Pin 9
C - Pin 12		J - Pin 10
C - Pin 13		J - Pin 11
C - Pin 14		J - Pin 12
C - Pin 15		J - Pin 13
C - Pin 16		J - Pin 14
C - Pin 17		J - Pin 15
C - Pin 18		J - Pin 16
C - Pin 19		J - Pin 17
C - Pin 20		J - Pin 18
C - Pin 21		J - Pin 19
C - Pin 22		J - Pin 20
C - Pin 23		J - Pin 21
C - Pin 24		J - Pin 22
C - Pin 25		J - Pin 23
C - Pin 26		
	Not Used	
C - Pin 63		
C - Pin 64		C - Pin 65
C - Pin 65		C - Pin 64
C - Pin 66		
	Not Used	
C - Pin 69		
C - Pin 70		C - Pin 76
C - Pin 71		
	Not Used	
C - Pin 75		
C - Pin 76		C - Pin 70
C - Pin 77		J - Pin 24

TABLE 19

WIRING LIST: INTERCONNECTION BETWEEN CONNECTORS G AND H

<u>Connector G Pin Number</u>	To	<u>Connector X - Pin XX</u>
G - Pin 1		H - Pin 1
G - Pin 2		H - Pin 2
G - Pin 3		H - Pin 3
G - Pin 4		H - Pin 4
G - Pin 5		H - Pin 5
G - Pin 6		H - Pin 6
G - Pin 7		H - Pin 7
G - Pin 8		H - Pin 8
G - Pin 9		H - Pin 9
G - Pin 10		H - Pin 10
G - Pin 11		H - Pin 11
G - Pin 12		H - Pin 12
G - Pin 13		H - Pin 13
G - Pin 14		H - Pin 14
G - Pin 15		H - Pin 15
G - Pin 16		H - Pin 16
G - Pin 17		H - Pin 17
G - Pin 18		H - Pin 18
G - Pin 19		H - Pin 19
G - Pin 20		H - Pin 20
G - Pin 21		H - Pin 21
G - Pin 22		H - Pin 22
G - Pin 23		H - Pin 23
G - Pin 24		H - Pin 24

TABLE 20

WIRING LIST: CONNECTOR C, MULTIPLEX SYSTEM REMOTE TERMINAL NO. 2

<u>Pin Number</u>	<u>Signal Type and Application</u>
3	Breadboard Electronics: Power On Reference
4	Breadboard Electronics: Sensor Test Source Signal τ_2
5	Breadboard Electronics: Sensor Test Source Signal τ_3
6	Breadboard Electronics: Sensor Test Source Signal τ_4
7	Breadboard Electronics: Engine 1 Fire Sensor 1A Signal
8	Breadboard Electronics: Engine 1 Fire Sensor 1B Signal
9	Breadboard Electronics: Engine 1 Fire Sensor 2A Signal
10	Breadboard Electronics: Engine 1 Fire Sensor 2B Signal
11	Breadboard Electronics: Engine 1 Fire Sensor 3A Signal
12	Breadboard Electronics: Engine 1 Fire Sensor 3B Signal
13	Breadboard Electronics: Sensor Test Source Signal τ_1
14	Breadboard Electronics: Sensor Test Source Signal τ_5
15	Breadboard Electronics: Engine 1 Fire Sensor 4A Signal
16	Breadboard Electronics: Engine 1 Fire Sensor 4B Signal
17	Breadboard Electronics: Engine 1 Overheat Sensor 1A Signal
18	Breadboard Electronics: Engine 1 Overheat Sensor 1B Signal
19	Breadboard Electronics: Engine 1 Overheat Sensor 2 Signal
20	Breadboard Electronics: Engine 1 Overheat Sensor 3 Signal
21	Breadboard Electronics: Engine 1 Overheat Sensor 4 Signal
22	Breadboard Electronics: Engine 1 Primary Extinguisher Status Signal
23	Breadboard Electronics: Engine 1 Secondary Extinguisher Status Signal
24	Breadboard Electronics: Sensor Test Source Signal τ_6
25	Breadboard Electronics: Manual Reset Switch
64	Mux Bite Input
65	Mux Bite Input
70	Plug Code Input
76	Breadboard Electronics: Signal Ground (Reference)
77	Plug Code Output

TABLE 21

WIRING LIST: INTERCONNECTION BETWEEN CONNECTORS B AND D

<u>Connector B Pin Number</u>	To	<u>Connector X - Pin XX</u>
B - Pin 1		D - Pin 19
B - Pin 2		D - Pin 20
B - Pin 3		D - Pin 21
B - Pin 4		D - Pin 22
B - Pin 5		D - Pin 23
B - Pin 6		D - Pin 24
B - Pin 7		D - Pin 25
B - Pin 8		D - Pin 26
B - Pin 9		D - Pin 27
B - Pin 10		D - Pin 28
B - Pin 11		D - Pin 29
B - Pin 12		D - Pin 30
B - Pin 13		D - Pin 31
B - Pin 72		D - Pin 76
B - Pin 76		D - Pin 72
B - Pin 77		D - Pin 77

SECTION VIII

FUTURE SYSTEM RECOMMENDATIONS

This program demonstrated the feasibility of using a central aircraft data acquisition system for hazard detection and warning. Utilization of a central data acquisition system and a Central Integrated Test System (CITS) for hazard detection and crew warning should be considered on future aircraft developments.

Hazard detection and warning systems, by nature, need to be highly reliable. This high reliability must be maintained when utilizing a data acquisition system and cannot be compromised to achieve lower costs and other benefits from use of the central aircraft computer. Fortunately, other flight-critical aircraft subsystems also require a highly reliable data system and thus the data system will have the needed performance and reliability.

Most hazard detection systems have sufficient performance reliability, and no significant advances in performance reliability can be achieved with the central aircraft computer. Some increases in confidence of system operation may result from the automated self testing feature offered by the central computer.

The primary advantage in using this new technology will be the reduction of both hardware costs and operational costs. Any reduction in the design and development costs of hazard detection hardware will be offset by the added systems integration costs and added hardware for memory capacity of the central computer and additional remote terminals.

A significant reduction in the cost of system changes is obtained since many changes can be made in software and not in hardware. The possibility exists of needing additional hazard sensors when problems develop after an aircraft becomes operational. Adding sensors or changing redundancy logic for crew warning might not be cost effective if dedicated signal processing hardware were involved, but with a data system the changes may be cost effective.

AFAPL-TR-77-77

Utilization of a data acquisition system by other subsystems has usually resulted in system cost reduction. No general statement can be made as to whether it is better to use the data system for hazard detection. This program did not address system cost. Each aircraft designer should consider both the dedicated hardware approach and the system integration approach using a central aircraft computer. Final choice should be made based on performance and life cycle cost benefits.

REFERENCES

1. Delaney, Charles L., "Fire Detection Performance in USAF Aircraft," AFAPL-TR-72-49, August 1972.
2. Trumble, T. M., "Integrated Fire and Overheat Detection System for Manned Flight Vehicles," AFAPL-TR-67-129, December 1967.
3. Leen, Albert, "An Ultraviolet Sensing Flame Detector for Use on High Performance Military Aircraft," AFAPL-TR-69-107, February 1970.
4. Bondley, R. J. "High Sensitivity 1000°F Gas Multiplication UV Flame Detector for Aircraft," AFAPL-TR-73-62, June 1973.
5. Entire, G., Farrell, R., Wilson, F., Wald, F., "Development and Testing of a Cadmium Telluride High Temperature (750°F) Infrared Fire Detector," AFAPL-TR-73-104, November 1973.
6. Fox, Duane G., "Development of Electronic Circuits for Advanced High Temperature Fire Detectors," AFAPL-TR-75-111, March 1976.
7. Raskauskas, B. J., "Integrated Fire and Overheat Detection System for Aircraft," AFAPL-TR-69-97, December 1969.
8. Suminski, George, Riemer, Otto, and Hankey, Frank, "Integrated Fire and Overheat Detection System," AFAPL-TR-76-64, June 1976.
9. Perry, J. L., Gross, J. P., Hoffman, M. H., "Multiplexing in Aircraft Subsystems," AFAPL-TR-73-41, Vol I and Vol II, July 1973.
10. Biard, J. R., "Optoelectronic Aspects of Avionic Systems II," AFAL-TR-75-45, May 1975.
11. McCuen J. W., Brian H. F., Curry, S. J., "Multiplex Techniques Safety Study," AFWL-TR-73-38, June 1973.
12. Military Standard, "Aircraft Internal Time Division Command/Response Multiplex Data Bus," MIL-STD-1553A, 30 April 1975.