

AD-A054 560

SOUTHWEST RESEARCH INST SAN ANTONIO TX ARMY FUELS AN--ETC F/G 11/8
DISCUSSION OF HYDRAULIC FLUID FLAMMABILITY HAZARDS.(U)

DEC 77 B R WRIGHT
AFLRL-95

DAAG53-76-C-0003
NL

UNCLASSIFIED

1 of 1
AD
A054560



END
DATE
FILMED
7 -78
DDC

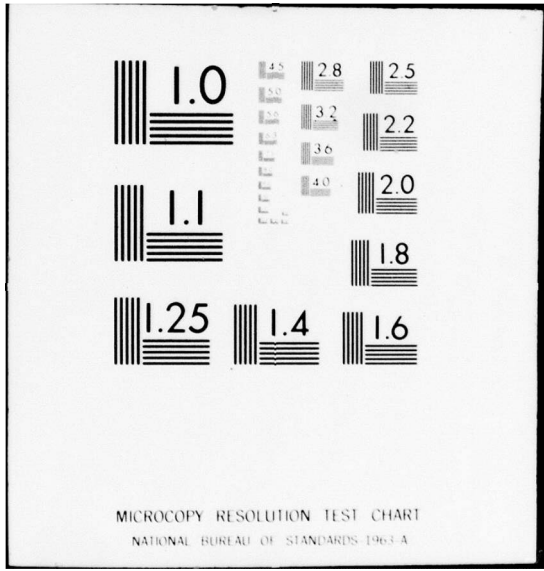

FOR FURTHER TRAN

Handwritten initials and signature

AD

AD A 054560

DISCUSSION OF HYDRAULIC FLUID FLAMMABILITY HAZARDS

INTERIM REPORT
AFLRL No. 95

By
Bernard R. Wright

DDC
JUN 1 1978
F

AD No. _____
DDC FILE COPY

Prepared by
U.S. Army Fuels and Lubricants Research Laboratory
Southwest Research Institute
San Antonio, Texas

Under Contract to
**U.S. Army Mobility Equipment Research
and Development Command**
Energy and Water Resources Laboratory
Fort Belvoir, Virginia

Approved for public release; distribution unlimited

Contract No. DAAK70-78-C-0001

December 1977

Disclaimers

The findings in this report are not to be construed as an official Department of the Army position unless so designated by other authorized documents.

Trade names cited in this report do not constitute an official endorsement or approval of the use of such commercial hardware or software.

DDC Availability Notice

Qualified requestors may obtain copies of this report from Defense Documentation Center, Cameron Station, Alexandria, Virginia 22314.

Disposition Instructions

Destroy this report when no longer needed. Do not return it to the originator.

Unclassified

SECURITY CLASSIFICATION OF THIS PAGE (When Data Entered)

REPORT DOCUMENTATION PAGE		READ INSTRUCTIONS BEFORE COMPLETING FORM
1. REPORT NUMBER 14 AFLRL [redacted] - 95	2. GOVT ACCESSION NO.	3. RECIPIENT'S CATALOG NUMBER
4. TITLE (and Subtitle) 6 Discussion of Hydraulic Fluid Flammability Hazards.		5. TYPE OF REPORT & PERIOD COVERED 9 Interim Report, 1 Oct 76 - 1 Oct 77
7. AUTHOR(s) 10 Bernard R. Wight		8. CONTRACT OR GRANT NUMBER(s) 15 DAAG53-76-C-0003, and DAK78-78-C-0001
9. PERFORMING ORGANIZATION NAME AND ADDRESSES U.S. Army Fuels & Lubricants Research Laboratory, Southwest Research Institute San Antonio, Texas 78284		10. PROGRAM ELEMENT, PROJECT, TASK AREA & WORK UNIT NUMBERS 12 26p.
11. CONTROLLING OFFICE NAME AND ADDRESS U.S. Army Mobility Equipment Research Development Command, Energy & Water Resources Lab., Ft. Belvoir, VA 22060		11. REPORT DATE 11 December 1977
14. MONITORING AGENCY NAME & ADDRESS (if different from Controlling Office)		12. NUMBER OF PAGES 22
		15. SECURITY CLASS. (of this report) Unclassified
		15a. DECLASSIFICATION/DOWNGRADING SCHEDULE
16. DISTRIBUTION STATEMENT (of this Report) Approved for public release; distribution unlimited		
17. DISTRIBUTION STATEMENT (of the abstract entered in Block 20, if different from Report)		
18. SUPPLEMENTARY NOTES		
19. KEY WORDS (Continue on reverse side if necessary and identify by block number) Fire-Resistant Hydraulic Fluid Pool Burning Ballistic Tests Mist Flammability		
20. ABSTRACT (Continue on reverse side if necessary and identify by block number) Hydraulic fluid flammability has been evaluated for fire-resistant fluid candidates and approved fluids. Hazards directly related to the M60A1 tank have been discussed. A systematic assessment of flammability modes and ignition sources is presented. Experimental results indicate that mist flammability is more (over)		

DD FORM 1473
 JUN 1 1978
 RECEIVED
 F

387 339

SM

Unclassified

SECURITY CLASSIFICATION OF THIS PAGE (When Data Entered)

20. ABSTRACT (cont.)

related to exposure conditions than to hydraulic fluid classes. Pool burning has been shown to be a major hazard, and the higher flash point fluids have been shown to provide a substantial margin of safety relative to conventional petroleum-base fluids. Results of ballistic tests using 20 mm HEIT projectiles demonstrated residual burning on the backstop (analogous to pool burning) only when conventional petroleum-base fluids were evaluated, otherwise, only a transient mist fireball was observed.

Unclassified
SECURITY CLASSIFICATION OF THIS PAGE (When Data Entered)

FOREWORD

This report was prepared at the U.S. Army Fuels and Lubricants Research Laboratory (AFLRL), Southwest Research Institute, under DOD Contract Nos. DAAG53-76-C-0003 and DAAK70-78-C-0001. The project was administered by the Fuels and Lubricants Division, U.S. Army Mobility Equipment Research and Development Command (MERADCOM), Fort Belvoir, Virginia 22060, with Mr. F.W. Schaekel, DRDME-GL, serving as Contracting Officer's Representative. The loan of a 20-mm rifle and the provision of a supply of 20-mm HEIT ammunition was arranged by the Project Manager—Vehicle Rapid Fire Weapon Systems, Rock Island Arsenal at the request of the Fuels and Lubricants Division of the U.S. Army Mobility Equipment Research and Development Command (MERADCOM).

Acknowledgment is given to Mr. R.B. Wangler, SwRI Safety Engineer and Mr. A.B. Wenzel, Director, Ballistics and Explosive Sciences for assistance in designing the ballistic test technique; to Messrs. A.C. Garcia, J. Kachich, and R.S. Marin for conducting the ballistic experiments; and to Mr. J.P. Pierce for conducting back-up flammability experiments. Special acknowledgment is given to Messrs. M.E. LePera, F.W. Schaekel, R.D. Quillian, Jr., A.A. Johnston, S.J. Lestz, and F.M. Newman and Dr. W.D. Weatherford, Jr. for their participation, encouragement, and suggestions.

TABLE OF CONTENTS

	<u>Page</u>
LIST OF TABLES	4
I. INTRODUCTION	5
A. Background	5
B. Objective	5
II. DISCUSSION	6
A. Systems Analysis	6
B. Hydraulic Fluid Properties	6
C. Hazard Analysis	6
III. FLAMMABILITY MODE ANALYSIS	9
A. Primary Ignition Sources	9
B. Secondary Ignition Sources	13
IV. CONCLUSIONS AND RECOMMENDATIONS	15
REFERENCES	16
APPENDIX A—Ballistic Evaluation of Hydraulic Fluids	17
APPENDIX B—Manifold Ignition Test	19
APPENDIX C—High-Temperature—High-Pressure Spray Ignition	21

ACCESSION for	
NTIS	White Section <input checked="" type="checkbox"/>
DDC	Buff Section <input type="checkbox"/>
UNANNOUNCED	<input type="checkbox"/>
JUSTIFICATION	
BY	
DISTRIBUTION/AVAILABILITY CODES	
DI	SPECIAL
A	



I. INTRODUCTION

A. Background

The development of a fire-safe hydraulic fluid has come a long way since the introduction of MIL-H-5606 fluid before World War II. This fluid is essentially a narrow-fraction kerosene containing viscosity-index improvers and other additives required to meet the requirements of a good hydraulic fluid. The initial requirements were designed with more concern over low- and high-temperature viscosities than with volatility and flammability. One improvement was made to this original fluid and that was to add corrosion inhibitors specifically for Army applications, and this modified fluid was designated MIL-H-6083. Researchers since as early as the mid-50's have been attempting to make this fluid more fire resistant or to develop a completely new fluid with improved fire safety characteristics. This goal is still being pursued today, and a far better understanding of the hazards encountered in hydraulic fluid systems has evolved. Also, great advances have been made in developing fluids that are more fire resistant; however, none has yet been developed that both satisfies the performance requirements of typical hydraulic fluids and is completely fire safe.

B. Objective

The purpose of this study has been to define the flammability hazards associated with hydraulic fluid systems in Army combat vehicles. A parallel objective has been to develop flammability tests that directly address these defined hazards. The primary threat considered is ballistic penetration of the pressurized hydraulic system causing fluid spillage inside the turret. Even though the fluid volume is relatively small, the major hazard arises from the fact that such a system is under high pressure, and the entire hydraulic fluid inventory may be spilled inside the crew compartment.

The initial phase of this program consisted of establishing a series of relevant flammability tests that could be used to evaluate the defined flammability modes.^{(1)*} These tests were useful also in establishing relative differences between the various hydraulic fluids. The second phase consisted of assessing the hydraulic system flammability hazards that had been defined. This task was accomplished by consulting with field personnel who had actual experience with the equipment. Also, consultation with personnel who had conducted post-battle inspections supplied an insight into the actual occurrences of hydraulic fluid participation in vehicular fires.⁽²⁾ Then, after reviewing the hazards that had been thus identified, flammability testing that would relate directly to these problems was initiated. The flammability testing not only included some standard tests but also included nonstandard tests (such as the 20-mm HEIT incendiary ballistic test described in Appendix A).

*Superscript references refer to references at end of report.

II. DISCUSSION

A. Systems Analysis

As an example, the turret hydraulic system used in the M60A1 tank can best be described as a low-pressure, open-loop, turret-mounted hydraulic fluid system. Generally, systems operating at approximately 1000 psi are referred to as low pressure, 2000 psi would be a medium-pressure system, and systems operating at 3000 psi or higher are referred to as high-pressure systems (typical of aircraft usage).

The open-loop characteristic refers to a manually-operated system controlled only by the crew inside the turret. Modification of the M60A1 to convert to the M60A2 is accomplished by adding a stabilizing system referred to as an Add-On Stabilizer (AOS). This modification allows continuous engagement of a target regardless of the terrain the tank is travelling. This addition converts the hydraulic system into a closed-loop system operating at 2000 psi. Incidentally, there are two separate systems included in the hydraulic system, these being the turret-rotating and the gun-elevation systems. The hydraulic system is driven by an electric motor that receives its power from a slip ring mounted in the hull. The problem of flammability is aggravated by the fact that the 18-20 liter hydraulic fluid reservoir, pump, high-pressure accumulator, and all lines are contained inside the turret. This design layout of the hydraulic system creates a hazardous situation since the crew is surrounded by a matrix of pumps and lines operating under pressure. The response of any of these components to ballistic penetration depends upon their location and function in the hydraulic system since the fluid pressure varies considerably depending upon the function and mode at the time of penetration.

B. Hydraulic Fluid Properties

Table 1 is a compilation of the laboratory tests that were completed on the various hydraulic fluids. It should be pointed out that the autoignition temperature was obtained with an apparatus constructed at AFLRL. This procedure is an adaptation of the ASTM D2155 procedure and utilizes a 90-cc aerosol reaction vessel and a microsyringe for sample injection. The test procedure is similar to D2155 with the exception that when the minimum AIT is reached, at least ten repetitions on an "up-and-down" basis (based on "go" or "no go") are taken; thus allowing a more precise statistical evaluation of the results. The results shown in Table 1 will be referred to later in the discussion whenever relevant.

C. Hazard Analysis

Investigations conducted by or supported by the Joint Technical Coordinating Group for Munitions Effectiveness (JTCGE) Battle Damage Assessment Reporting Program (BDARP) have documented the frequency and results of fire caused by hostile ballistic action. These studies have indicated that the hydraulic fluid system is potentially capable of causing severe damage to the vehicle and crew if the proper ignition source is available. These studies point out, however, that the fuel and ammunition are potentially more dangerous and actually participate in more of the fires (among those that were investigated). Nevertheless, the study does indicate that considerable damage and lost lives

TABLE 1. INSPECTION DATA FOR INVESTIGATED HYDRAULIC FLUIDS

Fluid	Viscosity cSt @ 37.8 °C (100 °F)	Viscosity cSt @ 99 °C (210 °F)	Flash Point, °C(°F)	Fire Point, °C(°F)	Auto- ignition Tempera- ture, °C(°F)	API Gravity (15.6 °C)	Pour Point, °C(°F)	Total Acid No. m KOH/gm
MIL-H-5606	12.74	4.27	103(217)	112(235)	238(460)	32.1	< -68(-90)	0.14
MIL-H-6083	13.43	3.86	102(215)	112(235)	238(460)	33.0	< -68(-90)	0.15
MIL-H-83282A	16.52	3.75	226(437)	252(483)	407(765)	33.1	< -68(-90)	0.15
MIL-H-46170	15.85	3.62	224(435)	250(480)	410(770)	32.7	< -68(-90)	0.03
Phosphate Ester	11.73	3.89	194(380)	208(405)	566(1050)	1.6	< -68(-90)	0.07
MS-5	40.54	11.35	250(480)	324(615)	363(685)	1.09	< -66(-87)	0.08
MIL-H-13919B	38.71	10.75	140(285)	155(310)	348(655)	30.6	< -64(-83)	0.57
Experimental Silicone A	34.19	8.18	282(540)	316(600)	436(815)	27.7	< -67(-87)	0.57
Experimental Silicone B	16.63	4.79	252(485)	271(520)	396(745)	30.8	< -67(-87)	0.72

could be reduced by the utilization of a fire-safe hydraulic fluid. For the purposes of this discussion, therefore, only the areas of hydraulic fluid fires will be addressed, recognizing that hydraulic fluid is only one of the fuels present in most ground-vehicle fires.

The following sequences of possible events represent potential hazards stemming from hydraulic fluid ignition. In order for a fire to occur, there must be a fuel and an ignition source capable of starting the fire and, of course, sufficient oxygen to support combustion. The less flammable a substance is, the more energetic the ignition source must be. It should be remembered that with the proper ignition source, even combustible dust particles will ignite, often violently; therefore, finely-dispersed hydraulic fluid spray could easily become an intense torch. The events following ballistic penetration could provide the following fuel and ignition source combination(s).

Fluid Exposure Modes

- High-pressure spray from high-pressure line rupture.
- Low-pressure sprays (dripping).
- Liquid pooling occurring upon rupture of hydraulic fluid reservoir or lines.
- Fluid-soaked solids such as clothing or debris.

Primary Ignition Sources

- Molten-metal jet or spalled particles.
- Ballistic incendiary blast.
- Hot surface at location of entry of ballistic round.

Secondary Ignition Sources

- Electric sparks.
- Flaming combustible material inside the turret.

III. FLAMMABILITY MODE ANALYSIS

The scope of this discussion is to address each flammability mode/ignition source as to its relevance to present studies being conducted at AFLRL and other laboratories.

A. Primary Ignition Sources

1. High Pressure Spray/Molten-Metal Jet-Spalled Particles

When a high-pressure line is ruptured by some means, either by direct penetration or by being jarred loose as a result of impact, various combinations of events can occur. Initially, of course, a mist spray would develop, and depending upon the size of the rupture, this spray could become more of a stream than a mist. Such a nonmisting stream could be more of a flammability hazard than a mist, as will be discussed later.

Finely-dispersed fuel droplets are a serious flammability hazard in the presence of a proper ignition source; however, AFLRL results (Table 2) have shown that once the ignition source is removed, the flame may not sustain itself. In the high-pressure spray test procedure (Fed. Test Std. 791B, Method 6052) that was utilized, the hydraulic fluid mist is formed by 68-atm (1000 psi) N₂ pressure forcing the fluid through a 0.4 mm (.014 in.) orifice. The pressure is not reduced as the fluid is sprayed as would be the case in some areas of the hydraulic system. The results of the ballistic tests conducted by Noonan^(3,4) showed essentially the same results as those obtained at this laboratory. If one can compare small calibre incendiary rounds with hot-spalled particles, his results showed no nonsustained fires in 123 tests with MIL-H-6083 fluid and no nonsustained fires in 165 tests with MIL-H-83282 fluid. These ballistic tests were also conducted using the standard 0.4 mm (0.014 in.) nozzle and 68 atm (1000 psi) gas pressure; however, these same results were not duplicated when an oil-burner nozzle was used. The point to be made is that the degree of atomization is an extremely important factor affecting the ignitability of a fluid. Although some sustained burning was obtained with the oil-burner nozzle, it is believed that this degree of atomization is not too realistic and that laboratory data indicate that, as a general rule, self-sustained fires would not occur with hot-particles ignition of high-pressure sprays.

TABLE 2. RESPONSE OF VARIOUS HYDRAULIC FLUIDS TO HIGH-PRESSURE SPRAY IGNITION
(Federal Test Standard 791B—Method 6052)

	Fluid	Results
1.	MIL-H-5606	Ignition at pilot, self-extinguishing flame
2.	MIL-H-6083	Ignition at pilot, self-extinguishing flame
3.	MIL-H-83282A	Ignition at pilot, self-extinguishing flame
4.	MIL-H-46170	Ignition at pilot, self-extinguishing flame
5.	MIL-H-13919B	Ignition at pilot, self-extinguishing flame
6.	MS-5	Ignition at pilot, self-extinguishing flame
7.	Phosphate Ester	No ignition at 6", 12" or 18"
8.	Experimental Silicone A	Ignition at pilot, self-extinguishing flame
9.	Experimental Silicone B	Ignition at pilot, self-extinguishing flame

2. Low-Pressure (Nonmisting Stream)/Molten-Metal Jet-Spalled Particles Ignition Source

When a hydraulic line ruptures, if the pressure is low, a nonmisting stream will result. If the only ignition source available is hot molten metal particles, there probably will not be a fire occurring unless the temperature of the liquid is near or above the flash point of the fuel. Rather, the particles would probably be quenched due to the difference in temperatures and the small mass of the individual particles.

3. Liquid Pool/Spalled Particles

If penetration of the hydraulic fluid reservoir causes a pool of liquid to be formed, it is highly probable that spalled hot particles would not be an intense enough ignition source to cause sustained ignition of the bulk liquid.

4. Fluid-Soaked Solids/Spalled Particles

One major cause of concern is the accumulation of oil-soaked debris in the floor of the turret. This concern is based upon the fact that a self-sustaining fire could occur in such debris and destroy the entire vehicle.

5. High-Pressure Sprays/Ballistic Incendiary Blasts

When an incendiary round penetrates a hydraulic fluid reservoir or line, a number of possibilities result. The parameters affecting these results would be the volume and temperature of the fluid and the duration and intensity of the incendiary exposure. The problem that occurs with ballistic impact is that there is sufficient energy to simultaneously create a flammable mist and to ignite it. Results of ballistic tests (Table 3) conducted at AFLRL using a pressurized hydraulic cylinder and 20-mm HEIT projectiles indicate that some fluids produce self-sustaining fires. Results indicated that the petroleum-based fluids (MIL-H-5606 and MIL-H-6083) produced a large fireball and sustained burning when subjected to the conditions of these ballistic tests. However, results obtained with other fluids generally showed a fireball (of various sizes) but no residual burning. Appendix A illustrates typical results obtained with two different fluids.

6. Low-Pressure (Nonmisting Stream)/Ballistic Incendiary Blast

This mode of flammability would probably not occur since, as mentioned previously, the energy release from a projectile is sufficient to simultaneously form a mist and to ignite it. This is due to the fact that enough energy is released to form a mist regardless of the condition of the fluid, as was indicated by the ballistic tests conducted at AFLRL.

7. Liquid Pool/Ballistic Incendiary Blast

This mode of flammability is similar to the mode previously discussed in that, almost regardless of the condition of the hydraulic fluid just prior to impact, the energetic ballistic round will undoubtedly form a mist and simultaneously ignite it. Flame propagation

TABLE 3. RESPONSE OF VARIOUS HYDRAULIC FLUIDS
TO BALLISTIC IMPACT OF 20-mm HEIT AMMUNITION

Fluid	Test Fuel Temperature		Remarks
	Ambient	77°C (170°F)	
MIL-H-5606	X	X	Impact Fireball, Sustained Burning
MIL-H-6083	X	X	Impact Fireball, Sustained Burning
MIL-H-83282A	X	X	Impact Fireball
MIL-H-46170	X	X	Impact Fireball
MIL-H-13919B	X	X	Impact Fireball, Some Sustained Burning @ 77°C
MS-5	X	X	Small Impact Fireball
Phosphate Ester	X	X	Small Impact Fireball
Experimental Silicone A	X	X	Small Impact Fireball
Experimental Silicone B	X	X	Impact Fireball

studies of bulk fluid have shown that the fluid had to be heated to near its flash point before even a wick would stay ignited, or certainly before a flame would propagate. Since this is an especially serious problem, a detailed review will be given of the chronological series of events following ballistic penetration of part of a hydraulic fluid system.

In a hydraulic system that is under pressure during normal operation, the operating temperature is around 100°C (212°F), and the fluid in the gun recoil mechanism may be substantially higher. Therefore, the normal operating temperature is near the flash point of the petroleum-base fluids that have been in use. Flame propagation studies have shown that once this fluid ignited, the flame should spread until total pool involvement has occurred. However, flame propagation occurs only after the temperature at the surface of the bulk liquid is near the flash point of the fluid. It is very improbable that the bulk temperature could be maintained at or near 200°C (or even reached) until ignition occurs. Hence, it is unlikely that bulk liquid involvement could ever occur with the newer fire-resistant hydraulic fluids. This has been further indicated by the ballistic tests conducted at AFLRL that showed residual burning with the petroleum fluids and no residual burning with the other fluids. It is interesting to note that another petroleum-based fluid was evaluated with the ballistic procedure, this fluid was a MIL-H-13919B fluid (now obsolete) that has a minimum flash point of 121°C (250°F) as compared to MIL-H-5606C fluid with a minimum flash point of 93°C (200°F). Results showed residual burning to be less extensive than with the MIL-H-5606C fluid, thus again showing a relationship between flash point and bulk liquid fire involvement. It should be emphasized, however, that the mist flammability characteristics are not directly related to flash point.

8. Fluid-Saturated Flammables/Ballistic Incendiary Blast

The hazard presented by the ignition of wicking materials is possibly greater than any other in the turret, because these materials do not require as intense an ignition source as the bulk fluid, and they would continue to burn after the ignition source is removed. Therefore, they act as an ignition source themselves. It should be recalled, however, that the fluid must be heated to near its flash point, even in a wick, and, therefore, the higher

flash-point fluids would require a more intense ignition source. Realistically, however, the incendiary blast from a projectile would probably act as an overwhelming ignition source for even the fire-resistant hydraulic fluids in a wicking matrix.

9. High-Pressure Spray/Hot Surface Ignition

The studies evaluating hot surface ignition of a fine-mist spray have shown that such a spray may not be ignited by surfaces heated to approximately 730°C (1350°F) (i.e., glowing red). In an effort to relate fire vulnerability to hot-surface ignition, it was determined that mist from petroleum-base fluids (FP ~ 100°C) would not ignite when sprayed onto surfaces heated to 730°C (1350°F). The same result was obtained with fire-resistant fluids. This result was entirely unexpected, and further experiments were conducted to help explain the results. The procedure that was used was a combination of the high-pressure spray apparatus (Fed. Test Std. 791B, Method 6052) and the hot manifold (Fed. Test Std. 791B, Method 6053). Table 4 shows that the degree of atomization greatly influences the surface temperature required for ignition.

TABLE 4. EFFECT OF ATOMIZING PRESSURE ON MIST FLAMMABILITY

Surface Temperature Required for Ignition, °C(°F)		
Fluid	High Pressure (68 atm)	Low Pressure
MIL-H-6083	No fire up to 730 (1350)	524 (975)*
MIL-H-83282	No fire up to 730 (1350)	400 (750)
MIL-H-46170	No fire up to 730 (1350)	400 (750)
Phosphate Ester	No fire up to 730 (1350)	676 (1250)
MS-5	649 (1200)	454 (850)
MS-6	649 (1200)	454 (850)
MIL-H-13919	No fire up to 730 (1350)	484 (900)
APG PD-1	No fire up to 730 (1350)	468 (875)

* Temperatures given $\pm 14^\circ\text{C}$ ($\pm 25^\circ\text{F}$).

In an effort to better understand those cases in which the fine mist would not ignite at the glowing red surface, various methods of mist generation were attempted. The standard procedure of Method 6052 used a 0.4 mm (0.014 in.) square-edge orifice and 68-atm (1000 psi) N₂ pressure. It was thought that perhaps the mist formed by this method produced an over-rich situation at the heated surface and that forced dilution with air might produce a fuel-air mixture in the flammable range. Therefore, in one series of experiments, the mist generation was accomplished using a smooth-bore fuel-delivery tube with mist being formed by three intersecting air jets that caused the fuel stream to break up into very fine droplets. The mist formed using this procedure of air impingement also would not ignite at surface temperatures up to 730°C (1350°F).

Further studies were conducted with mists formed by a standard nozzle from a T-63 turbine engine. These results showed that the mists formed by this procedure were ignited instantly upon coming into contact with the hot surface [$\geq 730^\circ\text{C}$ (1350°F)]. The same results were obtained with both petroleum-base fluids, thereby showing a relationship, once again, to particle size, rather than volatility.

10. Low Pressure Spray/Hot Surface Ignition

The previous section discussed the results obtained when a finely-atomized mist was sprayed over a surface heated to 730°C (1350°F). When a low-pressure (nonmisting) spray impinged on the same hot surface, the results were entirely different. Referring to Table 4 again, it is interesting to note that a reversal in hot-surface ignition temperatures of MIL-H-5606 (MIL-H-6083) relative to those of MIL-H-83282 (MIL-H-46170) is observed (relative to the minimum AIT) in the low-pressure spray procedure. Such results have also been observed by others. It would seem, therefore, that a low-pressure or dripping leak would be very hazardous due to the low temperature required for ignition.

11. Liquid Pool/Hot Surface Ignition

A liquid pool caused by leakage from a hydraulic fluid reservoir over a hot surface could have essentially the same results as a nonmisting stream impinging upon a hot surface. Therefore if the fluid did not reduce the surface temperature before ignition could occur, the total pool could become involved in pool burning.

12. Fluid-Soaked/Hot Surface Ignition

It would not be expected that saturated flammables would come in contact with hot surfaces resulting from projectile penetration.

B. Secondary Ignition Sources

In addition to the "primary" ignition sources that would result from projectile penetration of the turret and subsequently, some part of the hydraulic system, there could also be "secondary" ignition sources that could act as a primary ignition source inside the turret. The relevance of some of these situations will now be discussed in more detail.

1. Electrical Sparks

The evaluation of spark-originated fires has not been investigated in the present studies; however, it should be mentioned as one possible cause of hydraulic fluid fires. The turret-cupola slipring is an electromechanical device that provides uninterrupted flow of hydraulic fluid and electrical energy between the turret and the rotating cupola. This is only one example of electrical power and pressurized hydraulic fluid in close proximity, thus allowing electrical arcing to act as an ignition source in the event of ballistic disruption. Reports from BDARP covering battlefield-damaged vehicles have indicated that electrical arcing certainly could have acted as ignition sources not only for hydraulic fluids but also for spilled fuel.

2. Fluid-Soaked Combustibles/Wicking

One serious consideration at present is the extent of "housekeeping" inside armored vehicles. The problem of preventing oil-soaked dirt/sludge buildup that could act as fuel if exposed to the proper ignition source has caused some concern. Also personal gear or

clothing would be a fire hazard if soaked with fluid. The problem is that, generally, a low-intensity ignition source will ignite a wick, and once ignited, it can burn for an extended period of time. Therefore, even though burning wicking fires may not in themselves become serious threats, they can act as energetic ignition sources for other combustibles. As an example, as has been discussed previously, when a line ruptures, spraying a fine mist, the fire will generally not be self-sustaining if the ignition source is removed. However, with a burning wick, the continuing flame causes continued burning until the impinged-upon surface becomes heated and may cause pool burning to start. Therefore, this type of situation should be considered as a potentially serious hazard to be carefully controlled.

IV. CONCLUSIONS AND RECOMMENDATIONS

This study has shown that hydraulic-fluid flammability can be a very complex hazard. The described fluid-flammability modes and ignition sources represent idealized conditions for categorizing fluid-fire involvement, the degree of hazard depending to a great extent upon the amount, rate, and physical type of fluid discharge. It has been shown that hydraulic fluid mists are extremely hazardous with adequate ignition sources and that fluid spilled in the turret could be involved in pool burning. Although a more energetic ignition source could be required to achieve pool burning, such burning could be a more serious threat than mist fires. This is because most of the fluid may be ultimately consumed in a pool burning mode, thereby causing greater damage to the vehicle. It has been shown, however, that the newer, fire-resistant fluids with higher flash points are more fire-safe from a pool burning standpoint than the older, petroleum-base fluids.

It is important to place each flammability hazard in the proper perspective. Therefore, based on the results described herein, the following recommendations can be made:

- The standardized flammability evaluation procedures alone are not adequate for properly defining flammability properties.
- Of all of the hydraulic fluids that were evaluated, no one fluid appeared best in every test.
- Since a hydraulic fluid is subjected to many flammability hazards, guidelines should be established to assign priorities to the various measured flammability properties (e.g., for various fuel/ignition-source modes) relative to the specific application.

REFERENCES

- (1) Wright, B.R., Weatherford, W.D., Jr. and LePera, M.E., "Investigation of the Flammability Properties of Hydraulic Fluids," Final Report AFLRL No. 70, AD A019775, June 1975.
- (2) Personal Communication, Dale E. Woomert, et al, Mobility Branch, AMSAA.
- (3) Dailey, J.J., McEachin, R., "Some Observations on the Effectiveness of the SU RPG Weapon in Sea," JTCG/ME Discussion Paper, May 1976.
- (4) Noonan, W.P.J., "Ignition of Aircraft Hydraulic Fluid by Incendiary Ammunition," *Ballistic Research Laboratories, Memo No. 2246, November 1972.*
- (5) Noonan, W.P.J., "The Relative Ignitability of Hydraulic Fluids," *Ballistic Research Laboratories, Memo No. 204, March 1974.*

APPENDIX A BALLISTIC EVALUATION OF HYDRAULIC FLUIDS

In order to evaluate the ballistic response of various hydraulic fluids, a series of experiments was conducted at the ballistic facility located at Southwest Research Institute. The procedure utilized 20-mm HEIT ammunition and one liter of fluid (in a two-liter cylinder) under 68-atm, (1000 psi) N₂ pressure. Tests were conducted both at ambient (approximately 25 °C) and at 77 °C. The test plan called for at least duplicate experiments to be conducted at both temperatures. The sequence of events was followed with a video recorder and 16-mm color film at normal speed and 800 frames/sec.

The following photographs are single frames taken from the 800 frame/sec motion picture film. The time elapsed following impact is essentially the same for each fluid. The left-hand photographs show the results obtained with a MIL-H-6083 hydraulic fluid. In every experiment, a large fireball developed followed by continued burning on the rear wall after the fireball self-extinguished. The right-hand photographs show the results obtained with a typical fire-resistant hydraulic fluid when evaluated with this test procedure. It illustrates that the mist fireball that developed is essentially the same as the fireball that was observed with the OHT fluid; however, continued burning of the fluid never occurred, even at the elevated test temperature condition. Thus a margin of safety was demonstrated in that continued burning inside of a vehicle may not occur.

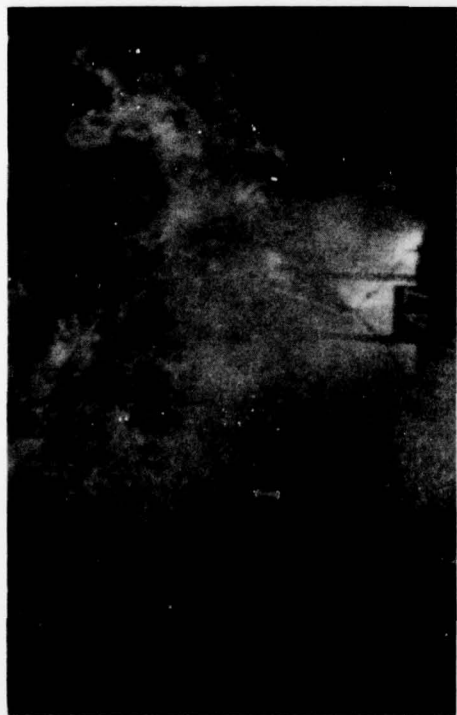

Maximum Fireball, MIL-H-6083 Hydraulic Fluid

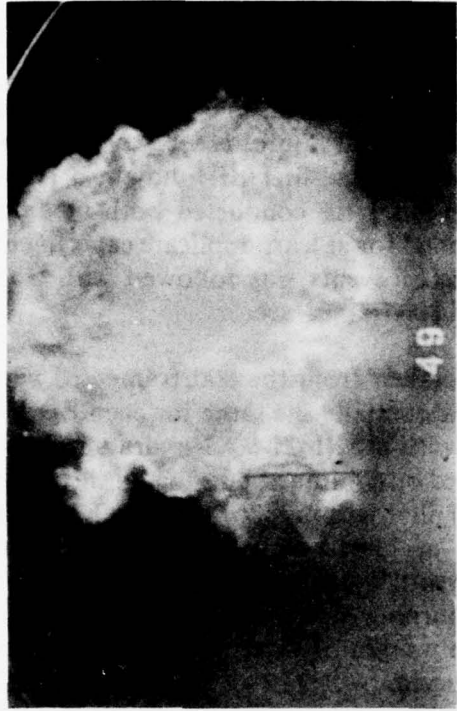

Maximum Fireball, MIL-H-46170 Hydraulic Fluid



Post-Impact Residual Fires, MIL-H-6083 Hydraulic Fluid



Post-Impact Smoke, MIL-H-46170 Hydraulic Fluid

BALLISTIC RESPONSE OF CONVENTIONAL AND FIRE-RESISTANT HYDRAULIC FLUIDS AT
TYPICAL MAXIMUM OPERATIONAL TEMPERATURE OF 77° C (170° F) [20 MM HEIT -
1 LITER OF FLUID AT 68 ATM (1000 PSI)]

**APPENDIX B
MANIFOLD IGNITION TEST
FEDERAL TEST STANDARD 791B, METHOD 6053**

1. Scope

1.1 This method is used for determining the relative flammability of a liquid in contact with a hot surface.

2. Apparatus

2.1 Simulated manifold test setup (Figure 1), consisting of three elements made of 18-8 stainless steel (AISI Type Numbers 302, 303, or 304) and a thermocouple.

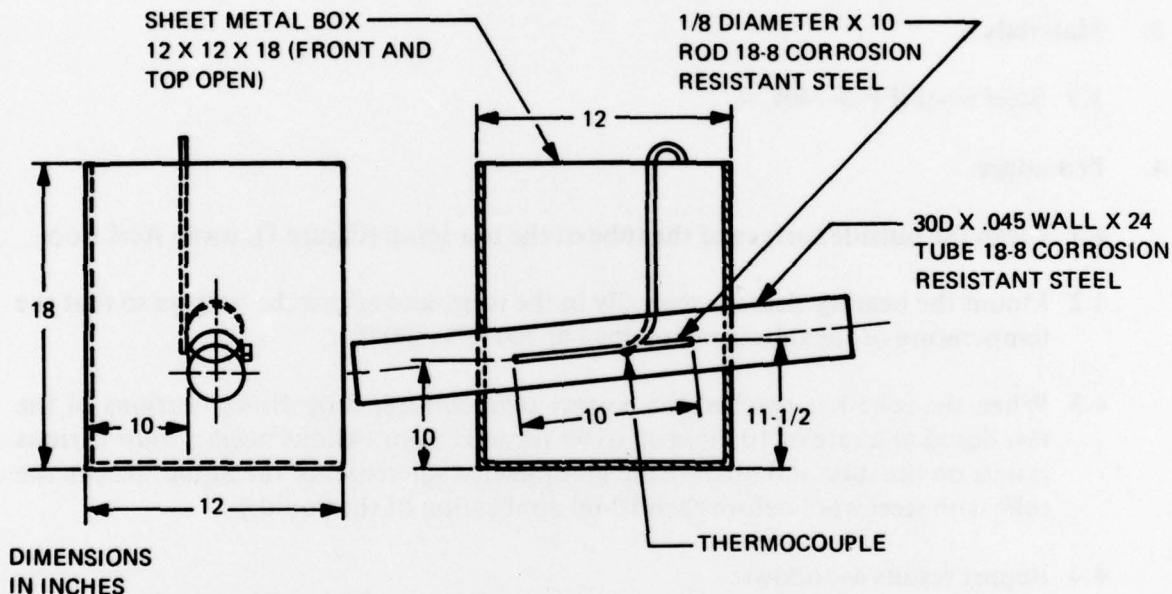

FIGURE 1. SIMULATED MANIFOLD TEST SETUP

- (a) Box, open in the front and on the top, made of sheet stock of suitable thickness, and measuring 12 inches wide by 12 inches deep by 18 inches high. The sides of the box shall contain two holes located so as to hold a 3-inch diameter tube at an angle as shown in the figure.
- (b) Tube, 3 inches in OD, 24 inches in length, and 0.045 inch in wall thickness. Sandblast the exterior surface of the tube with sharp, dry, white sand which meets the following sieve requirements of Federal Specification RR-S-366.
 - (1) 100 percent of the sand shall pass through a No. 10 sieve.
 - (2) A minimum of 90 percent of the sand shall pass through a No. 20 sieve.

- (3) A maximum of 10 percent of the sand shall be permitted to pass through a No. 50 sieve.
 - (d) Rod, 1/8 inch in diameter and 10 inches in length. Tack weld the rod to the exterior surface of the tube as shown in Figure 1.
 - (e) Thermocouple. Tack weld the thermocouple or attach it by other suitable means to a position on the exterior of the tube directly opposite to that of the 1/8-inch rod. Make certain, when attaching the thermocouple, to provide a minimum of additional radiating surface.
- 2.2 Heating element, electrical, "globar" type or equivalent, (Carborundum Company, AT, 31 x 12 x 1, 0.633-ohm unit, or equal), with suitable means for controlling the temperature of the tube to 704 °C (1300 °F).

3. Materials

- 3.1 Steel wool (FF-S-740).

4. Procedure

- 4.1 Clean the outside surface of the tube of the test setup (Figure 1), using steel wool.
- 4.2 Mount the heating element centrally in the tube, and adjust the voltage so that the temperature of the tube is maintained at 704 °C (1300 °F).
- 4.3 When the tube has reached the correct temperature, drop 10 ml portions of the test liquid at a rate of 10 ml in 40 to 60 seconds from various heights onto various points on the tube and observe the ignition characteristics of the liquid. (Clean the tube with steel wool before each 10-ml application of the liquid.)
- 4.4 Report results as follows:
 - (a) Flashes or burns on the tube, but does not after dripping from the tube.
 - (b) Does not flash or burn on tube, but does after dripping from the tube.
 - (c) Does not flash or burn on the tube or after dripping from the tube.

Method 6053, January 15, 1969 Prepared By Army—RIA—1966.

APPENDIX C
HIGH-TEMPERATURE—HIGH-PRESSURE SPRAY IGNITION
FEDERAL TEST STANDARD 791B, METHOD 6052

1. Scope

1.1 This method is used for determining the relative flammability of liquids. It consists of forcing the sample through a 0.0145-inch orifice at 1000 psi, attempting to ignite the spray with a torch, and noting the characteristics of the resulting flame.

2. Sample

2.1 Sufficient liquid to be tested to fill cylinder of spray test setup (see 3.1).

3. Apparatus

3.1 Spray test setup, similar to Figure 1 (for applying constant 1000 ± 10 psi, to sample).

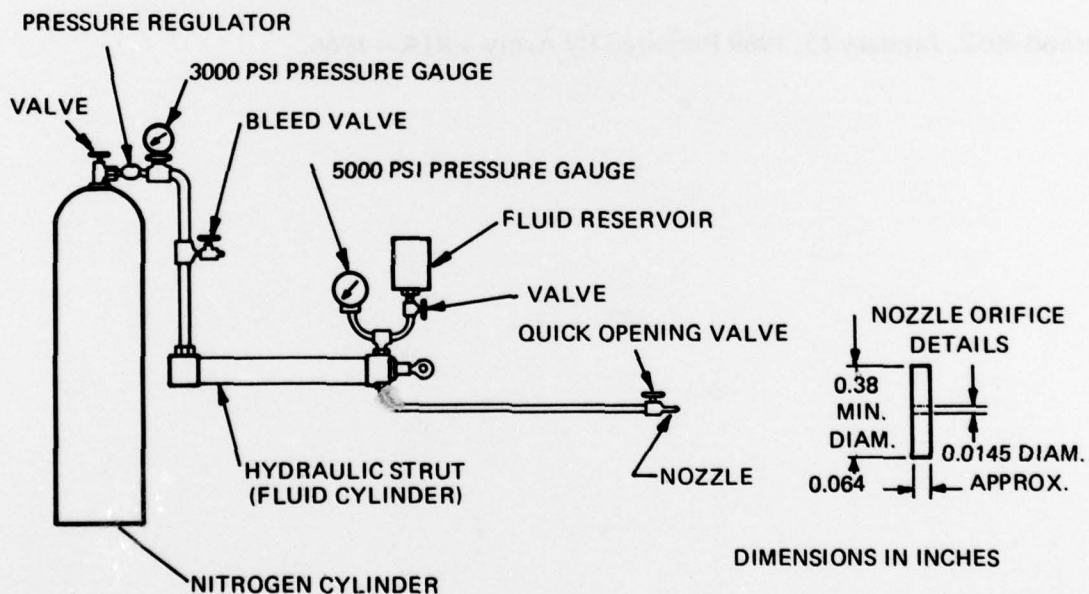

FIGURE 1. SPRAY TEST SETUP

3.2 Torch, oxyacetylene, equipped with No. 3 Purox tip or equal.

3.3 Nozzle, 0.064 inch thick by 0.38 inches minimum diameter; with a centered orifice, approximately 0.0145 inches in diameter, having sharp, square edges. (See Figure 1.)

4. Procedure

- 4.1 Fill cylinder of spray test setup with specimen at 60° to 100°F, and adjust gas pressure to produce a liquid pressure of 1000 ± 1 psi.
- 4.2 Adjust the torch to deliver a neutral flame.
- 4.3 Open the quick-opening valve at the orifice, and attempt to ignite the spray with the torch at the nozzle.
- 4.4 If the spray does not ignite, move the torch gradually away from the nozzle until ignition takes place (18 inches max.).
- 4.5 Report whether the spray ignites. If the spray does ignite, also report:
 - (a) The distance from torch to nozzle at ignition.
 - (b) Whether the spray flashes readily or with difficulty.
 - (c) Whether the flame produced is self-extinguishing or sustained.

Method 6052, January 15, 1969 Prepared By Army—RIA—1966.