

AD-A054 636

NAVAL RESEARCH LAB WASHINGTON D C  
EVALUATION OF AN ELECTROCHEMICAL DETECTOR FOR TRACE CONCENTRATI--ETC(U)  
APR 78 R A SAUNDERS, J J DECORPO

F/G 7/1

UNCLASSIFIED

NRL-8199

SBIE-AD-E000 156

NL

| OF |  
ADA  
054636

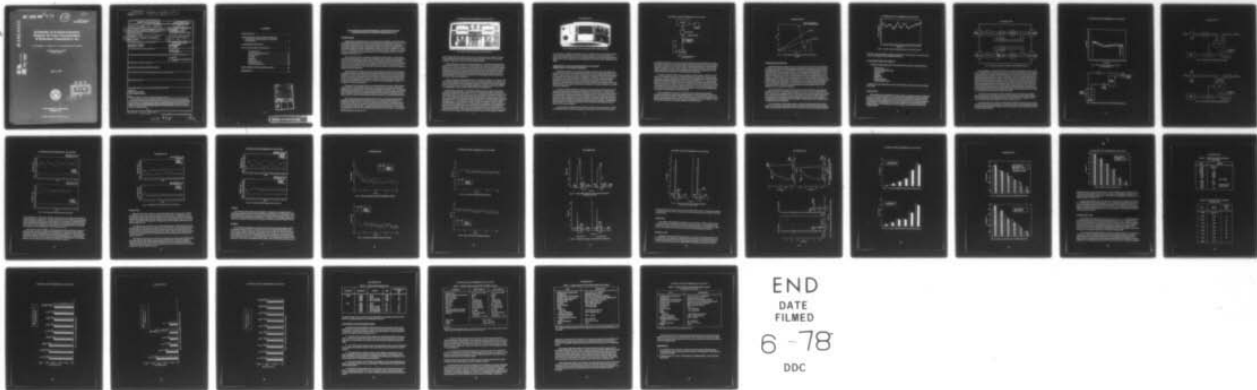

END  
DATE  
FILMED  
6-78  
DDC

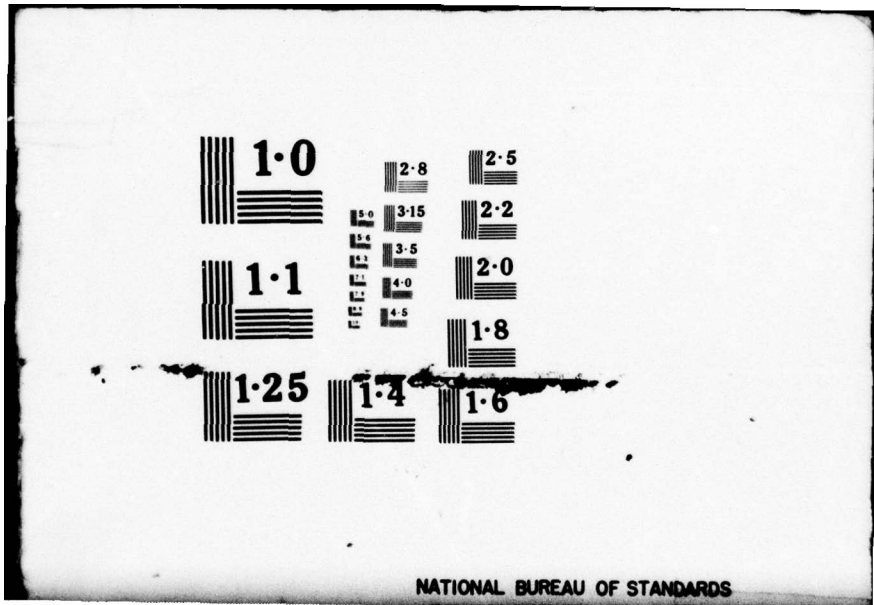

NATIONAL BUREAU OF STANDARDS

FOR FURTHER TRAN

Handwritten scribbles

BS 12 (circled)

5/17

ADE 000156  
NRL Report 8199

AD A 054636

AD No. \_\_\_\_\_  
DDC FILE COPY

# Evaluation of an Electrochemical Detector for Trace Concentrations of Hydrazine Compounds in Air

R. A. SAUNDERS, J. J. DeCORPO, B. J. STAMMERJOHN and R. J. KAUTER

*Chemical Diagnostics Branch  
Chemistry Division*

April 13, 1978



DDC  
RECEIVED  
JUN 6 1978  
B

Handwritten signature

NAVAL RESEARCH LABORATORY  
Washington, D.C.

Approved for public release; distribution unlimited.

(18) SBIE (19) AD-E/PP 156

SECURITY CLASSIFICATION OF THIS PAGE (When Data Entered)

REPORT DOCUMENTATION PAGE		READ INSTRUCTIONS BEFORE COMPLETING FORM
1. REPORT NUMBER NRL Report 8199	2. GOVT ACCESSION NO. (14) NRL-8199	3. RECIPIENT'S CATALOG NUMBER (12) 35p.1
4. TITLE (and Subtitle) (6) EVALUATION OF AN ELECTROCHEMICAL DETECTOR FOR TRACE CONCENTRATIONS OF HYDRAZINE COMPOUNDS IN AIR.		5. TYPE OF REPORT & PERIOD COVERED (9) Final report... phase of a continuing NRL Problem.
7. AUTHOR(s) (10) R. A. Saunders, J. J. DeCorpo, B. J. Stammerjohn and R. J. Kautter		6. PERFORMING ORG. REPORT NUMBER
9. PERFORMING ORGANIZATION NAME AND ADDRESS Naval Research Laboratory Washington, D.C. 20375		8. CONTRACT OR GRANT NUMBER(s) (11) 13 Apr 78
11. CONTROLLING OFFICE NAME AND ADDRESS		10. PROGRAM ELEMENT, PROJECT, TASK AREA & WORK UNIT NUMBERS NASA-CC-05899A C07-08-611 <i>for site report</i>
14. MONITORING AGENCY NAME & ADDRESS (if different from Controlling Office)		12. REPORT DATE April 13, 1978
		13. NUMBER OF PAGES 35
		15. SECURITY CLASS. (of this report) Unclassified
		15a. DECLASSIFICATION/DOWNGRADING SCHEDULE
16. DISTRIBUTION STATEMENT (of this Report)  Approved for public release; distribution unlimited.		
17. DISTRIBUTION STATEMENT (of the abstract entered in Block 20, if different from Report)		
18. SUPPLEMENTARY NOTES		
19. KEY WORDS (Continue on reverse side if necessary and identify by block number)  Hydrazines Electrochemical detection Trace contaminant detection		
20. ABSTRACT (Continue on reverse side if necessary and identify by block number)  Large quantities of nitrogen tetroxide and hydrazine compounds will be used in space shuttle operations. These materials are toxic, and the nearby environment must be monitored for escaped fuels at concentrations of a few parts per billion. Based on an analytical method recommended by the Naval Research Laboratory (NRL), prototype portable monitors have been built by Energetics Science, Inc., Elmsford, N.Y., and evaluated at NRL. The instruments meet design criteria and should be satisfactory for NASA's intended purpose.		

DD FORM 1 JAN 73 1473

EDITION OF 1 NOV 68 IS OBSOLETE  
S/N 0102-014-6601

SECURITY CLASSIFICATION OF THIS PAGE (When Data Entered)

251 954

AM

CONTENTS

INTRODUCTION ..... 1

GENERATION OF LOW CONCENTRATIONS OF  
HYDRAZINE COMPOUNDS IN A DYNAMIC  
GAS STREAM ..... 3

CALIBRATION PROCEDURE ..... 5

EVALUATION TESTS AND RESULTS ..... 6

    Functional Test ..... 6

    Zero and Span Stability Tests ..... 11

    Response Time ..... 13

    Accuracy ..... 14

    Sensitivity ..... 14

    Battery Test ..... 18

    Interference Tests ..... 18

    Tubing Transport Tests ..... 22

CONCLUSIONS AND RECOMMENDATIONS ..... 29

REFERENCES ..... 32

ACCESSION FOR	
NTIS	Full Section <input checked="" type="checkbox"/>
DOC	Full Section <input type="checkbox"/>
UNASSIGNED	<input type="checkbox"/>
JUSTIFICATION	
BY	
DISTRIBUTION/AVAILABILITY CODES	
Dist.	AVAIL. and/or SPECIAL
A	

PRECEDING PAGE BLANK-NOT FILMED

## EVALUATION OF AN ELECTROCHEMICAL DETECTOR FOR TRACE CONCENTRATIONS OF HYDRAZINE COMPOUNDS IN AIR

### INTRODUCTION

Large quantities of hydrazine (H), monomethylhydrazine (MMH), and unsymmetrical dimethylhydrazine (UDMH) are used for various purposes, including rocket propulsion, with the attendant possibility that some of these materials can contaminate the surroundings. Hydrazine compounds are toxic. Threshold limit values (TLV) have been established by the Occupational Safety and Health Administration (OSHA) at 0.2 ppm for MMH and 1.0 ppm for H. As a consequence, there is a need for portable instrumentation capable of monitoring hydrazine compounds at concentrations a factor of ten lower than the TLVs, i.e., 20 ppb for MMH and 100 ppb for H.

The National Aeronautics and Space Administration (NASA) plans to use hypergolic fuel systems including large quantities of H and MMH in space shuttle operations scheduled to begin at the Kennedy Space Center (KSC) in 1979. Shuttle operations at the landing strip, the orbiter processing facility, the hypergolic maintenance facility, and the launch pad could result in the leakage of fuel components into the atmosphere. It is therefore imperative for the protection of the environment and nearby personnel that KSC have accurate and reliable monitoring equipment.

The toxicity and tumorigenic properties of the hydrazines make their low-level detection essential. Permitted exposure levels are necessarily limited by state-of-the-art detection capability. The Navy, which manufactures hydrazines, and the Army and Air Force, which use the compounds in large quantities, share common problems and interests with NASA in the safe use and handling of these compounds. Therefore, the Department of Defense also benefits from this NASA-sponsored effort to improve monitoring capability for trace concentrations of hydrazine compounds.

Personnel of the Chemistry Division of the Naval Research Laboratory (NRL) had previously studied the atmospheric decomposition of hydrazine compounds and considered methods for the analyses of these compounds in submarine atmospheres. NRL was therefore asked by KSC to recommend one or more analytical methods to serve as a basis for the development of a suitable monitor for hydrazine compounds. The requested information was provided to KSC in a series of interim progress reports, followed by a summary final report [1].

NRL recommended electrochemical detection. This type of detection system offers specificity and high sensitivity and has the other obvious characteristics required for a portable monitoring device. Two methods of approach were possible. One was to develop an electrochemical detector specific to hydrazine compounds. If a specific detector could not be developed within the time constraints imposed, the alternative was to use commercially available, off-the-shelf electrochemical cells sensitive to NO and NO<sub>2</sub>. It was intended

Manuscript submitted December 29, 1977.

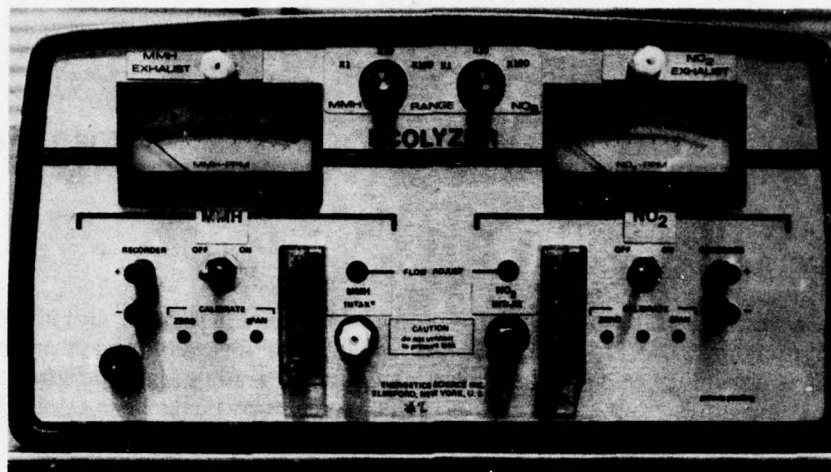

Fig. 1—Ecolyzer, Series 7000. (Photo courtesy of NASA.)

that the latter detection system would be used in conjunction with a catalytic converter. It was determined that a portable, battery-powered catalytic unit can convert enough hydrazine compound to  $\text{NO}_2$  to make this approach feasible.

$\text{NO}$  and  $\text{NO}_2$  also occur in the normal atmosphere at concentrations approximately equivalent to the amount of  $\text{NO}_2$  to be expected from the conversion of hydrazines when present at the lowest concentrations to be monitored. The  $\text{NO}$  in the ambient atmosphere would also be converted to  $\text{NO}_2$ , along with any hydrazine compound present. However, since  $\text{NO}$  and  $\text{NO}_2$  can be determined independently of each other with a dual-detector, electrochemical instrument, trace concentrations of hydrazine compounds in air at the minimum detection level could be monitored as an  $\text{NO}_2$  surrogate without interference from  $\text{NO}$  or  $\text{NO}_2$  in the background.

NASA contracted with Energetics Science, Inc. (ESI) of Elmsford, N.Y., which manufactures electrochemical detection devices, for two prototype monitors for hydrazine compounds based on NRL's recommendations. ESI elected to follow the first course suggested above and developed a detector with high sensitivity for hydrazine compounds and little or no sensitivity for other potential contaminants in the environment.

ESI provided prototypes in two different embodiments. One, based on their Series 7000 Ecolyzer instrument line, is shown in Fig. 1. The Ecolyzer model is a dual-channel instrument, actually two instruments in one, with one channel for hydrazine compound and one for  $\text{NO}_2$ . Each channel is entirely separate and independent and has its own air pump, flow-control system, and detector cell. Each channel has three sensitivity ranges with multiplying factors of 1, 10, and 100. The detection ranges are 0—2—20—200 ppm for hydrazine compound and 0—5—50—500 ppm for  $\text{NO}_2$ . The other embodiment is based on ESI's Series 6000 Hipster instrument line. The Hipster, Fig. 2, is designed to be suspended at the user's hip from a shoulder strap. It is a much smaller and lighter instrument, designed for field use on rechargeable battery power. The instrument has only one channel, and two separate Hipsters must be used to determine both hydrazine compounds and  $\text{NO}_2$ . The Hipster model has two ranges, with multiplying factors of 1 and 10. The sensitivity ranges are

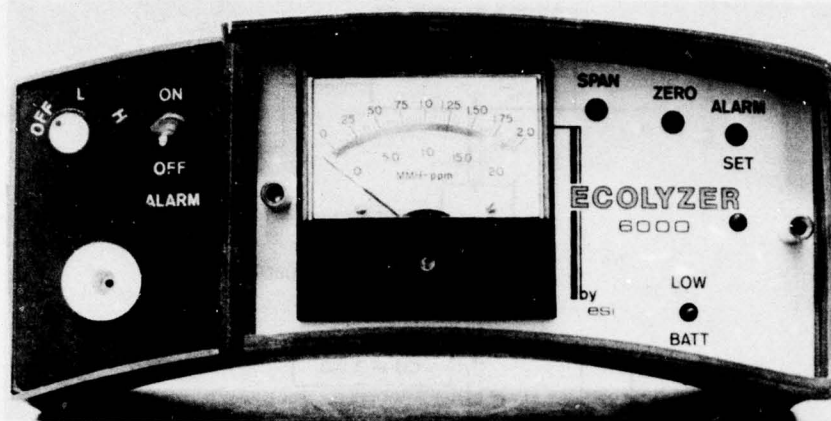

Fig. 2 — Ecolyzer, Series 6000 (Hipster model). (Photo courtesy of NASA.)

0—2—20 ppm for hydrazine compound and 0—5—50 ppm for  $\text{NO}_2$ . The prototype units of each model were submitted to NRL for testing and evaluation. The  $\text{NO}_2$  channels were tested using calibrated mixtures of  $\text{NO}_2$  in nitrogen stored in compressed gas cylinders. This mixture was, in turn, calibrated with a chemiluminescence  $\text{NO}/\text{NO}_2$  meter (McMillian Model 2000).

#### GENERATION OF LOW CONCENTRATIONS OF HYDRAZINE COMPOUNDS IN A DYNAMIC GAS STREAM

Testing and evaluation of an instrument designed to monitor trace concentrations of hydrazine compounds in air obviously requires some method for generating a dynamic gas stream containing such compounds in the desired concentration range. Blending gas streams in a multivalve and flowmeter system is unsatisfactory. Hydrazine compounds are prone to decompose in such a system. Moreover, it is difficult to keep such a system properly adjusted because a change in flow at any point in the system upsets the flow at all other points. To circumvent these problems, a novel Teflon gas dilutor was designed at NRL using multiventuri jets. The system was described in detail in Ref. 1 and is the subject of a current NRL patent application.

A more conventional alternative method was used to generate the test streams for the ESI prototypes pending construction and evaluation of the new dilutor. A motor-driven microliter syringe was used to inject liquid hydrazine compound into a gas stream flowing at a controlled rate. The sample flow system is illustrated in Fig. 3. The tube into which the liquid is injected is narrowed at the point of injection to lower the pressure and increase the rate of flow. This increases the rate at which the liquid hydrazine compound is evaporated from the needle tip and aids in the efficient mixing of the two components. The gas stream is then passed to a 2 l volume to further improve the blending of the stream and the uniformity of output concentration.

It was necessary to warm the point of injection with an electric heater tape to increase the evaporation rate and prevent condensation of hydrazine compound on the tube walls.

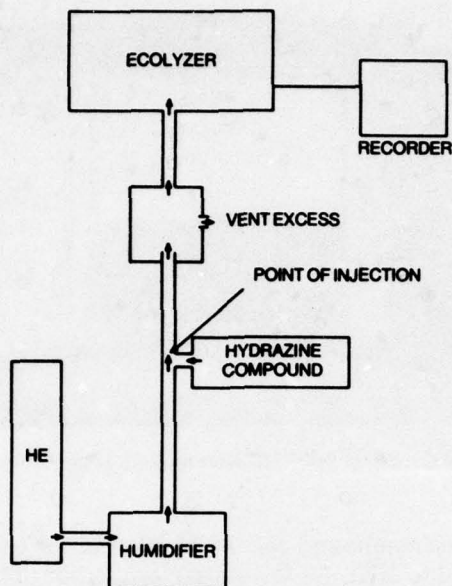

Fig. 3 — Gas stream generator and flow system

It was further necessary to cool the septum and needle region with an airstream to prevent evaporation of liquid in the syringe and needle. Bubbles in this region cause severe irregularities in the concentration of the output stream. A gas stream drawn from a compressed gas cylinder is usually very low in relative humidity. The electrochemical cells contain a water solution and tend to be dried out if a dehydrated gas is sampled for long periods. The gas stream was therefore saturated with water before the dilution step.

This type of generator system does not produce an output stream of uniform concentration. At a nominal concentration of 2 ppm hydrazine compound, the actual concentration varies  $\pm 0.5$  ppm over periods of several minutes. This results from a number of factors including unavoidable irregularities in the very slow liquid feed rate—i.e.,  $1 \mu\text{l/h}$  into a gas stream of 2 l/min—and changes in the rates of evaporation, adsorption and decomposition. This lack of uniformity in output stream concentration, which can be observed as a varying meter deflection when the stream is directly connected to one of the test instruments, can be smoothed and minimized by first collecting the stream in a 2-l Teflon gas sampling bag, from which it is then pumped to the detector cell.

Both H and MMH were used for the evaluation tests. Unsymmetrical dimethylhydrazine (UDMH) was not used. The relative sensitivities of the instruments to these compounds is in the order  $H > MMH > UDMH$ . MMH is the most convenient test compound. Gas streams containing H exhibit more pronounced wall effects, and it is more difficult to maintain a stable concentration, especially at higher concentration levels.

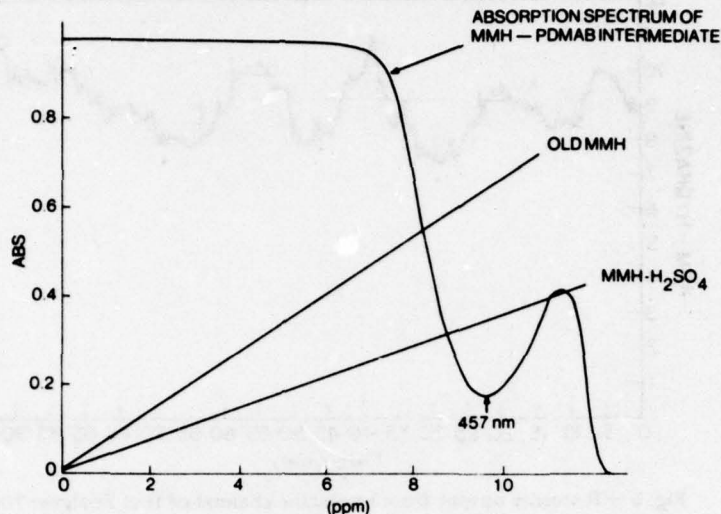

Fig. 4 — Typical calibration curves for colorimetric determination of MMH

#### CALIBRATION PROCEDURE

Spectrophotometric analyses were used to determine the concentration of hydrazine compound in the generator output gas stream. Hydrazine compounds react with a number of reagents to produce colored intermediates. Reaction with paradimethylaminobenzaldehyde (PDMAB) produces a yellow product with an absorption maximum at 457 nm. The absorption curve of the PDMAB intermediate and a typical plot of absorptivity vs concentration for MMH are shown in Fig. 4. Approximately 20 min are required for the color to develop to a stable intensity. After several hours the color again increases in intensity and changes absorption characteristics. The absorptivity of the colored solution during the stable period is linear with concentration. The minimum levels of detection for H and MMH are 0.07 and 0.125 ppm, respectively. It is convenient to use the acid salts of the hydrazine compounds instead of the liquid compounds themselves when making dilutions of the standard solutions required for calibration.

The color produced by the reaction between the various hydrazine compounds and PDMAB is the same; i.e., absorption is maximum at 457 nm, but the intensity differs for a given concentration. Hydrazine itself, for example, produces a color five times more intense than that produced by MMH at the same concentration. One bottle of MMH acquired for the evaluation tests was found to produce absorption measurements twice as intense as standards made with MMH-sulfate salt. This effect would be produced by an MMH sample containing 20% H as an impurity.

The concentration of hydrazine compound in the dynamic gas stream can be determined on a volume-per-volume basis (ppb) or a weight-per-volume basis ( $\text{mg}/\text{m}^3$ ) by passing the stream through a bubbler at a known flow rate for a measured time and calculating

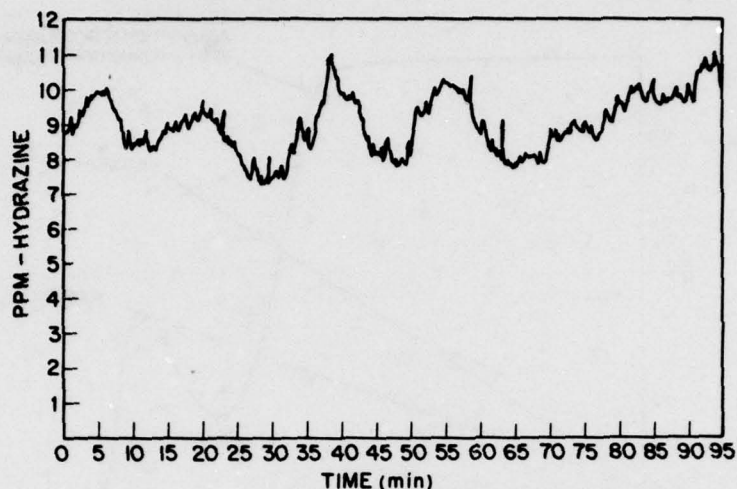

Fig. 5 — Recorder output from hydrazine channel of first Ecolyzer 7000

the total weight of hydrazine compound present from the calibration curve and the intensity of color developed when PDMAB is added [2].

#### EVALUATION TESTS AND RESULTS

The six prototype instruments were subjected to the battery of tests listed below.

- Functional test
- Zero and span stability tests
- Response time
- Accuracy
- Sensitivity
- Battery test
- Interference tests
- Tubing transport tests

A description of these tests and comments concerning the results are given in the material that follows.

#### Functional Test

Each instrument was operated for at least 3 weeks on an 8h/day basis and occasionally for 24 h while connected directly to the output of the gas generator in order to ascertain instrument reliability. At first, recorder traces similar to Fig. 5 were obtained. The trace illustrated is from the MMH/H sensor of one of the Model 7000 units. Some fluctuation in meter deflection was attributable to unavoidable variations in the concentration of the generated test gas. The rest seemed to be from leakage in the instrument's internal air-handling system.

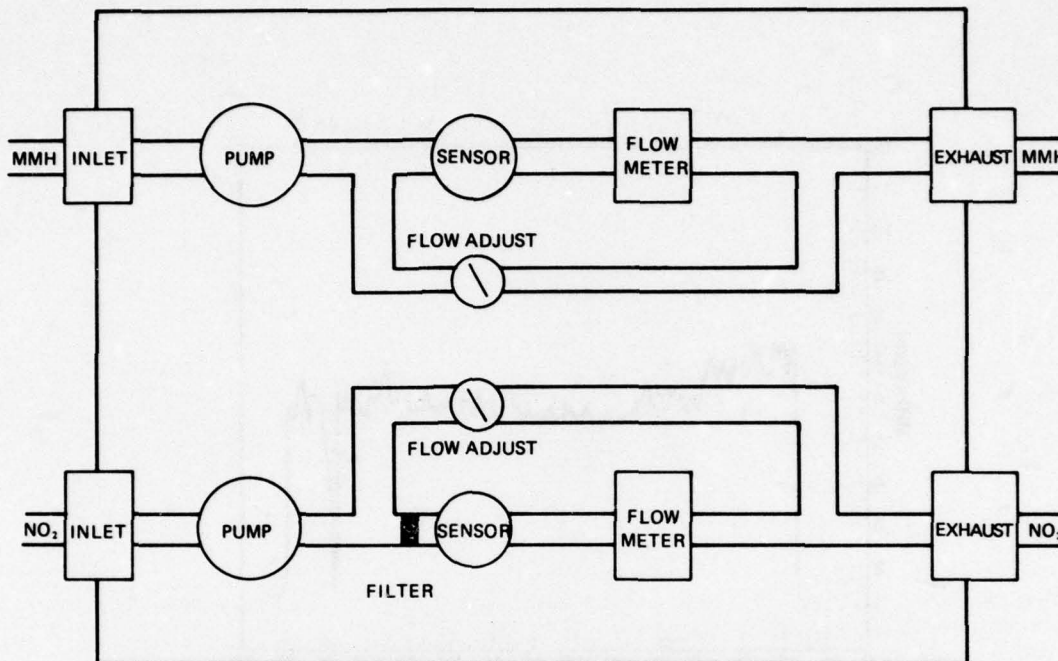

Fig. 6 — Original flow diagram for the Series 7000 NO<sub>2</sub>/MMH Analyzers

A flow diagram of a Series 7000 Ecolyzer in its original configuration is shown in Fig. 6. The original pump for the hydrazine channel was one of a variety having Teflon surfaces in motion against one another under spring tension. The Teflon was loaded with a ceramic material to minimize cold flow. However, wear and/or cold flow occurred nonetheless and caused leakage and fluctuation in airflow. The Teflon pumps in the Model 7000 units were replaced with the rubber bellows used in the NO<sub>2</sub> channels. The pumps for the hydrazine channels were also relocated downstream from the detector cells. Relocation prevents the error in measuring hydrazine concentrations that is due to adsorption in the rubber pump parts. Minor alterations were also made in the airflow balancing circuits. These changes, coupled with the ensuing decrease in plumbing between the instrument inlet and the detector cell, significantly improved the stability of the original Model 7000 instruments. Figure 7 is a typical recorder output from the improved units.

The position of the pump for the NO<sub>2</sub> channels was not changed from its original location upstream from the detector cell. The final configuration of the airflow system in the hydrazine channel of the Model 7000 unit is shown in Fig. 8. Flow diagrams for the NO<sub>2</sub> and MMH Series 6000 Analyzers are shown in Figs. 9 and 10.

It was also noted over a period of weeks that the vibration of the flow pump caused a loosening of the Teflon tube fittings in the hydrazine channel. Loose fittings permit leakage and cause stability problems. A different type of fitting will be used in production models to minimize this condition.

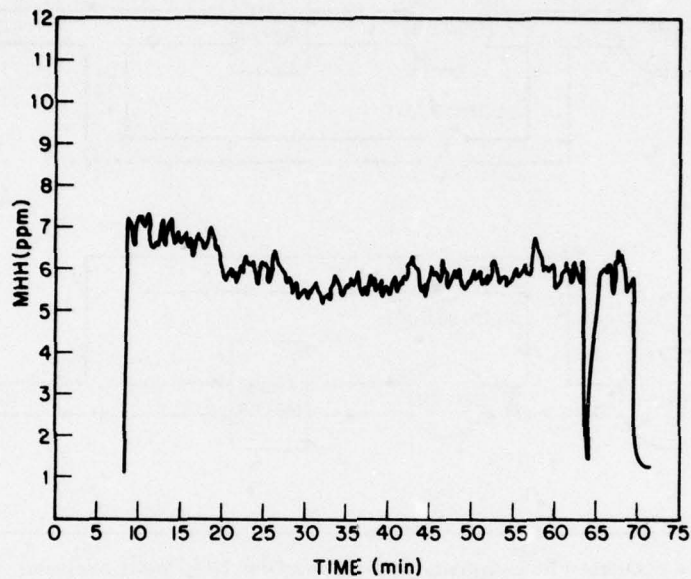

Fig. 7 — Ecolyzer 7000 recorder output with new pump arrangement

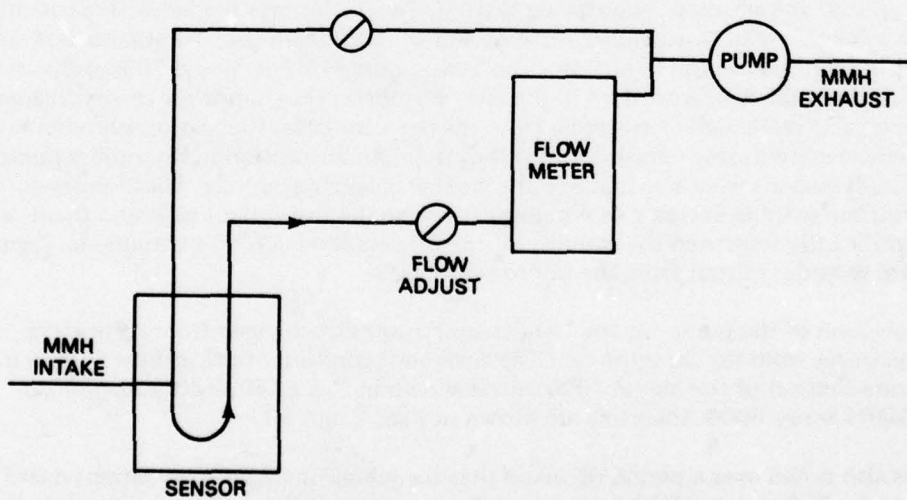

Fig. 8 — Modified flow diagram for Model 7000 hydrazine channel

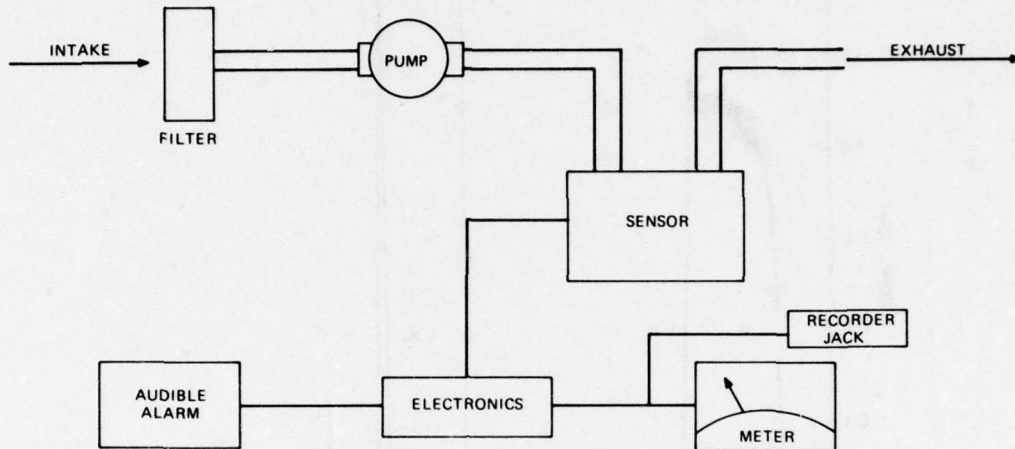

Fig. 9 — Flow diagram for Model 6000 NO<sub>2</sub> Analyzer

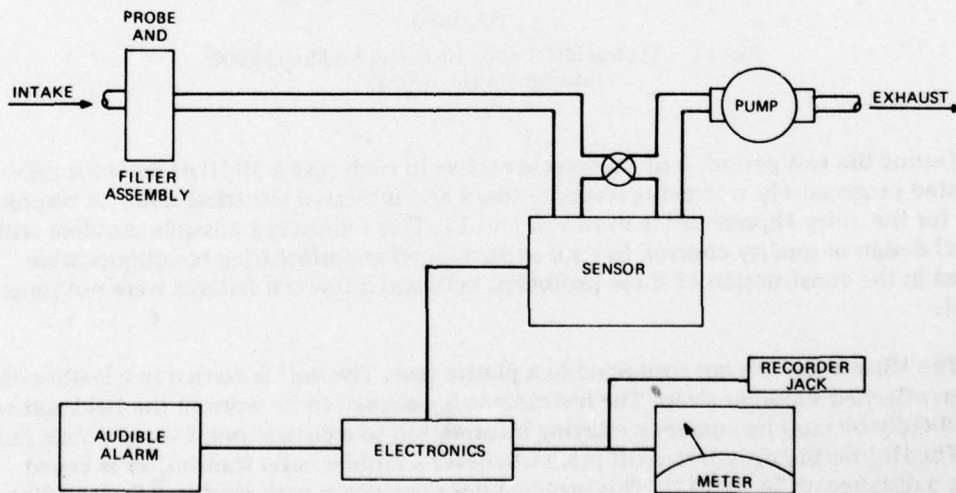

Fig. 10 — Flow diagram for Model 6000 MMH Analyzer

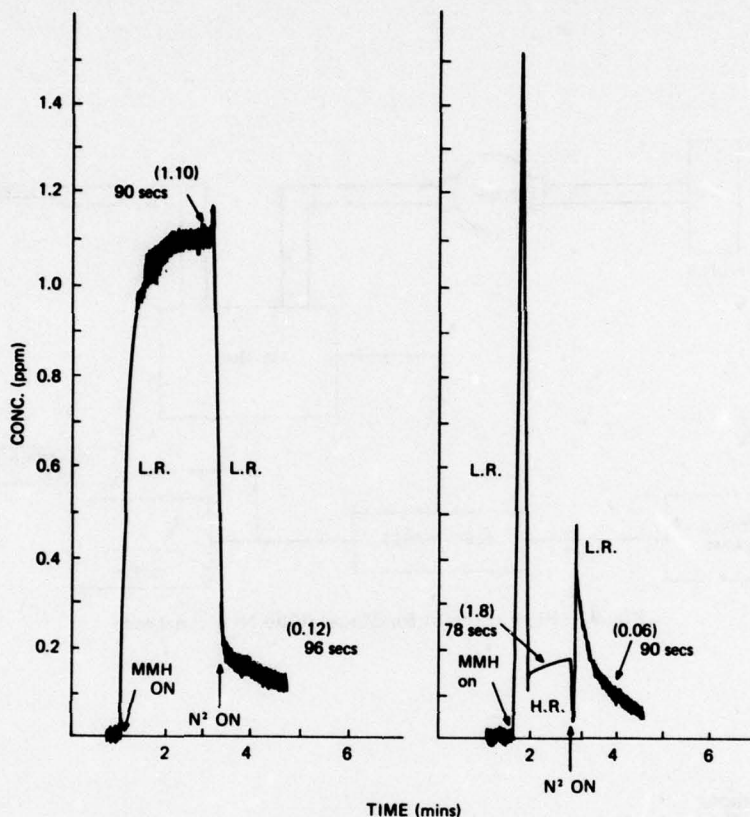

Fig. 11 — Typical MMH response curves for Model 6000  
(Instrument No. B/002)

During the test period, 2 of 10 detector cells—in each case a MMH/H detector cell—exhibited progressively worsening response times and increased electrical noise. A response curve for the noisy Hipster cell is shown in Fig. 11. This indicates a possible problem with the cell design or quality control. Several experimental manufacturing techniques were utilized in the construction of these prototype cells and a few cell failures were not unexpected.

The Hipster models are contained in a plastic case. The unit is carried in a leather case with an attached shoulder strap. The instrument is designed to be worn in the field and will undoubtedly be used by someone relaying information to a central point via a mobile radio link. The Hipster meter is driven off scale whenever a mobile radio transmitter is keyed within a distance of 25 to 30 ft. This problem does not occur with Ecolyzer Series 7000 models, which are contained in a metal case. Lining the leather case of the unit with Mu Metal would be one way to eliminate radio interference.

The detector cell in the Hipster units is sensitive to orientation and must be operated no more than  $10^\circ$  off vertical, i.e., with the meter faceplate parallel to the ground. The panel meter on the prototype Hipsters has a jewel movement, which is also position sensitive.

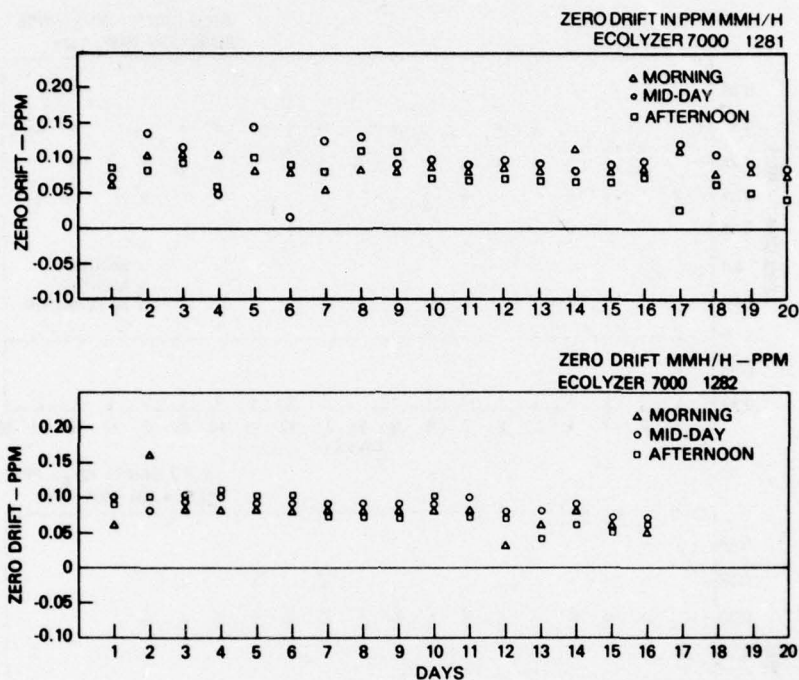

Fig. 12 — MMH/H Ecolyzer 7000; measured zero drift in ppm

The meter face must be held parallel to the ground, or a variable false deflection of the meter will occur. The instrument would be improved as far as field use is concerned if the present meter were replaced with a dual-needle system analogous to those used on many aneroid barometers, if such a meter were available within reasonable cost, weight, and size restrictions. One needle would follow the instantaneous analog signal and the other, a resettable lock needle, would indicate (and hold until reset) the maximum position reached by the first. A digital readout would be another alternative.

#### Zero and Span Stability Tests

Three times each day for 20 consecutive working days, each instrument was connected to a Teflon bag containing pure nitrogen. The instrument was zeroed each morning on the first nitrogen bag. Immediately thereafter, a second bag containing 2 ppm of a hydrazine compound (or  $\text{NO}_2$ ) in nitrogen was connected to the instrument, and the maximum reading was recorded. The bag of nitrogen was then reconnected, and a second zero reading was taken. The difference between the first and second zero reading was recorded and plotted as the zero stability. The zero stability of all of the prototype instruments was found to be excellent. Typical zero stability data for MMH and  $\text{NO}_2$  are given in Figs. 12–15. The hydrazine and  $\text{NO}_2$  readings were recorded and plotted as the span stability. These data are illustrated in Figs. 16–19.

The average deviation in the span stability measurements was  $\pm 0.5$  ppm for a 2-ppm nominal concentration. One design requirement of the instruments was a span stability of

SAUNDERS, DeCORPO, STAMMERJOHN, AND KAUTTER

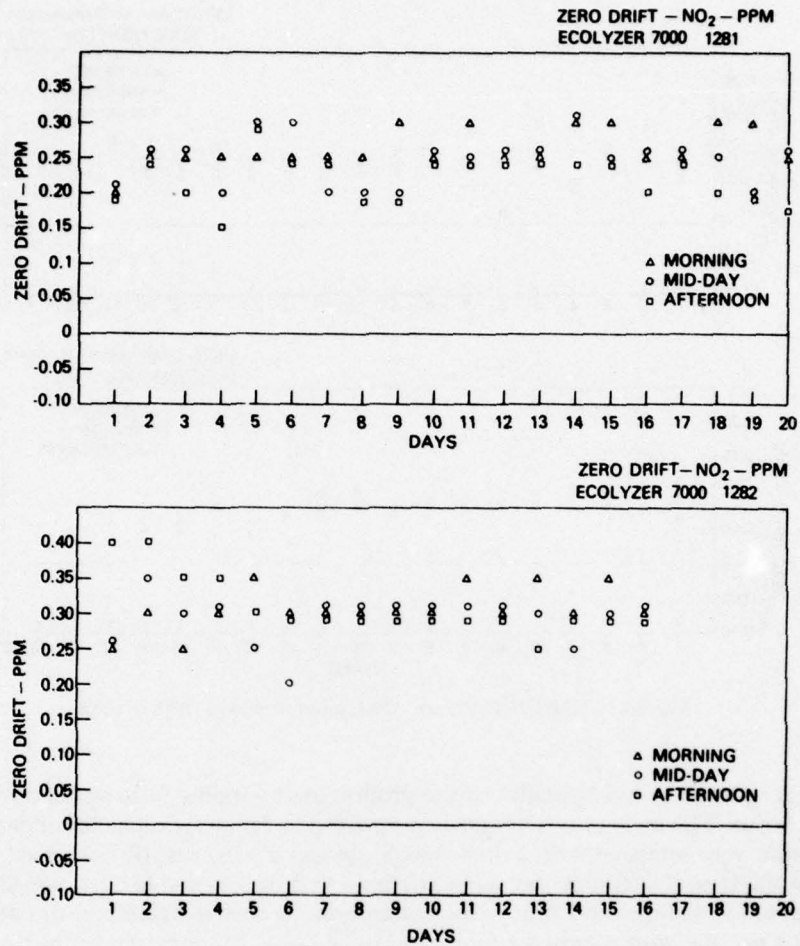

Fig. 13 - NO<sub>2</sub> Ecolyzer 7000; measured zero drift in ppm

±10% of full scale or, in this case, ±0.2 ppm. The instruments probably meet the span stability specification, in spite of the ±0.5-ppm deviation measured, because the method used for determining span stability also reflects errors in the concentration of the MMH sample attributable either to decomposition of the MMH or to the variables produced by the generator, which were discussed in a previous section. The errors attributable to these causes may well account for the additional ±0.3-ppm deviation noted.

The decrease in span for MMH on both instrument models for the first four days of operation, Figs. 16 and 17, appears to be characteristic of new detector cells. After the fourth day, the span essentially leveled off and showed only slight, but constant, decrease through the remainder of the 20-day test. The span measurements for the NO<sub>2</sub> detector cells, on the other hand, did not exhibit this characteristic. Both instrument models gave a flat span curve for NO<sub>2</sub> for the entire test period (Figs. 18 and 19).

NRL REPORT 8199

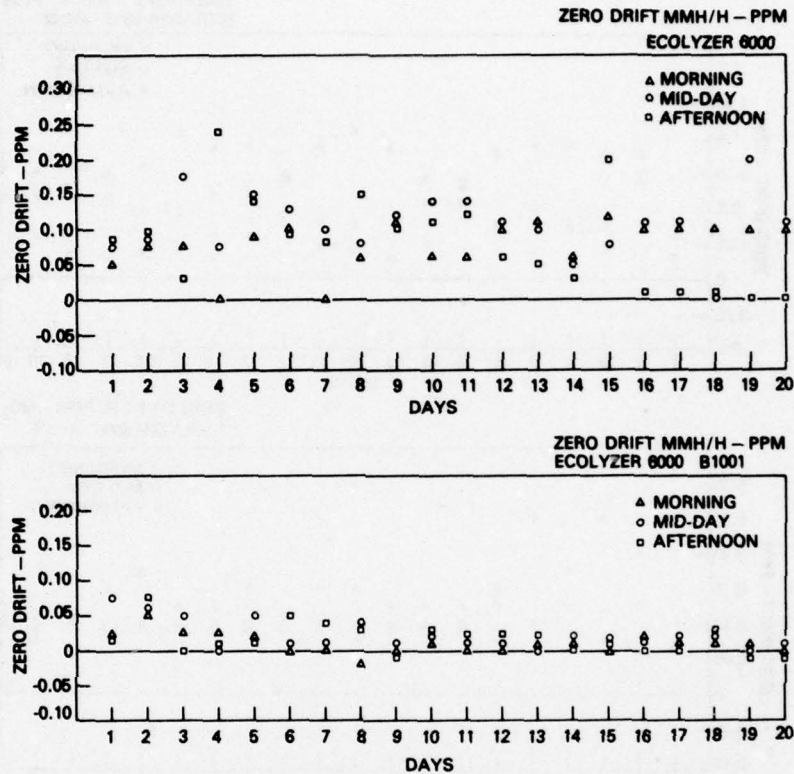

Fig. 14 - MMH/H Ecolyzer 6000; measured zero drift in ppm

**Response Time**

Response times were measured by zeroing the instruments on a bag of pure nitrogen, replacing the nitrogen with a bag of hydrazine compound or NO<sub>2</sub> in nitrogen at a known concentration, and recording the time required for the instrument to reach 90% of its final reading. The nitrogen sample was then replaced, and the time required for the instrument to return to within 10% of the original zero reading was recorded. Typical response curves are shown in Figs. 20-23.

The response time exhibited by one of the Ecolyzer units, No. 1281 (Fig. 22), was not as good as that for instrument No. 1282 (Fig. 20). The difference probably results from the fact that different experimental assembly techniques were used in the manufacture of the cells (see Fig. 24). Obviously, the technique of No. 1282 is better than the other and should be used for the production models. The response time for the better cell is well within the design requirement.

The Hipster models respond to hydrazine compounds much faster than the Series 7000 Ecolyzers (Fig. 22). This is because the physically smaller detector cells in the Hipsters require less reaction time. There is also less transport distance in the Hipster between the instrument inlet and the detector cell. The response times for the NO<sub>2</sub> detector cells in both models were excellent (Figs. 21 and 23).

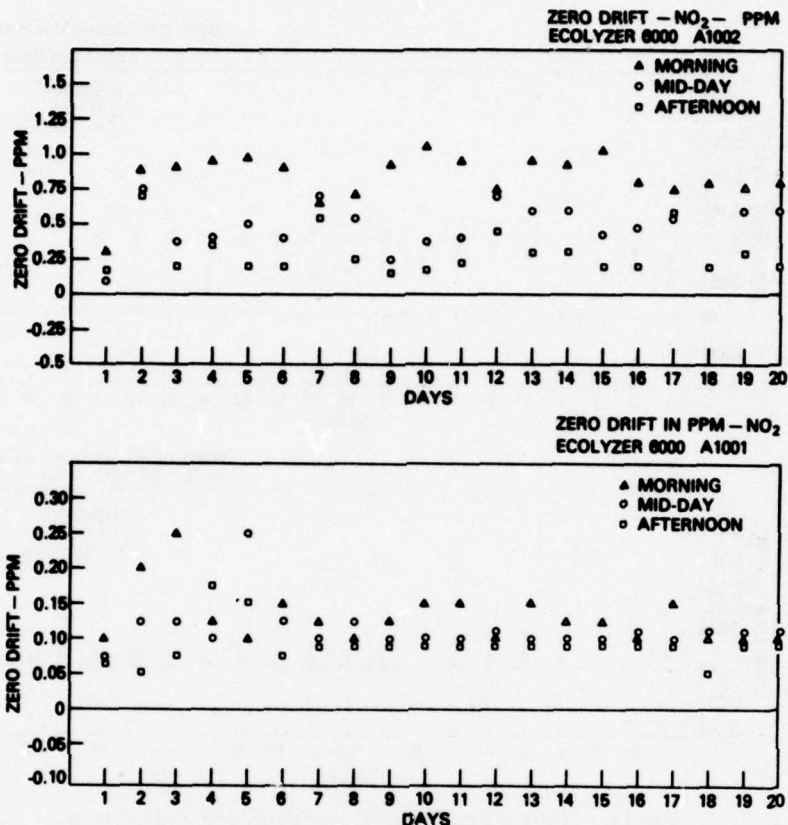

Fig. 15 - NO<sub>2</sub> Ecolyzer 6000; measured zero drift in ppm

**Accuracy**

The accuracy of the instruments was tested by exposing them to bagged samples of hydrazine compound and NO<sub>2</sub> at various different concentrations and comparing the instrument readings with the known concentrations. The results obtained include whatever error is inherent in spectrometrically determining the concentrations of the bagged samples. The results were very good. The data for the hydrazine detectors are plotted in Figs. 25 and 26.

**Sensitivity**

The instrument sensitivities were determined by successively diluting bagged samples of hydrazine compound or NO<sub>2</sub> by a factor of two until a measurable deflection of the meter could no longer be discerned. The results are shown in Figs. 27-29. The sensitivities of the instruments were within the required range. These measurements were made under ideal conditions, however. It is doubtful that such low concentrations could be determined in the field while on the move. A practical sensitivity for the instruments in field use would appear to be 200 ppb for both MMH and NO<sub>2</sub>. These values miss the design requirements by

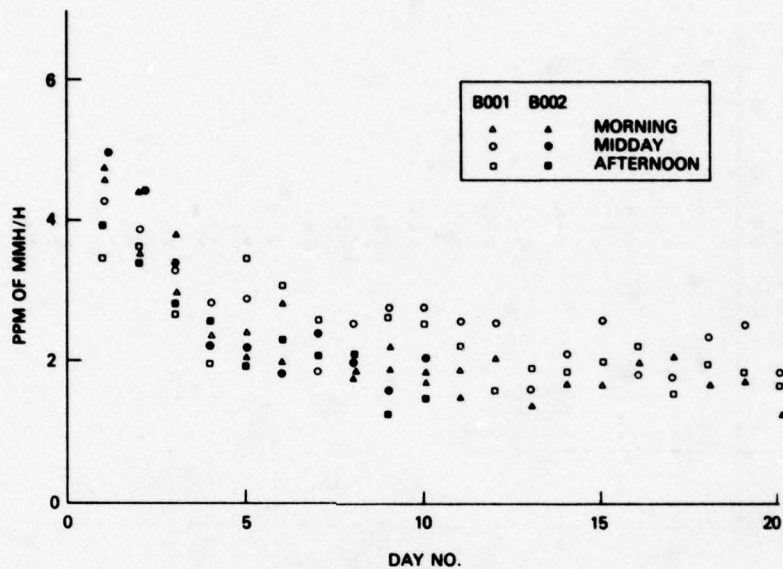

Fig. 16 — Span measurements for Model 6000 MMH/H Analyzers

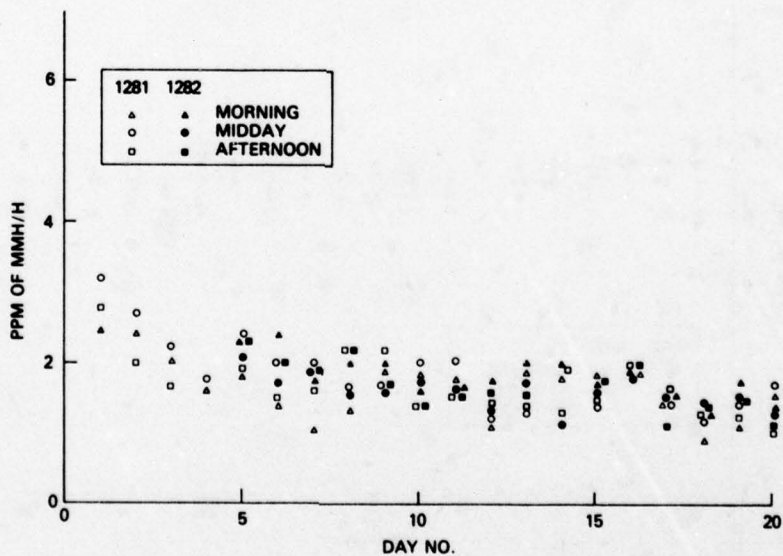

Fig. 17 — Span check for MMH/H Model 7000 Analyzer

SAUNDERS, DeCORPO, STAMMERJOHN, AND KAUTTER

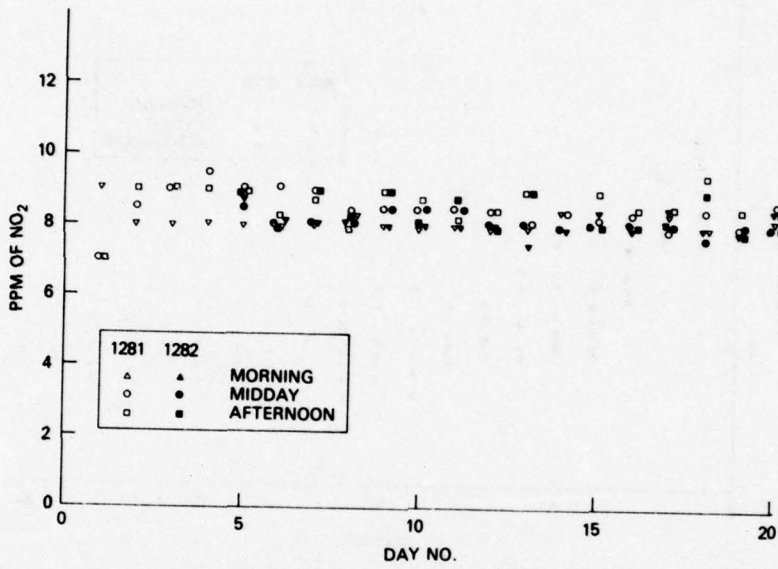

Fig. 18 — Span check for Model 7000 NO<sub>2</sub> Analyzer

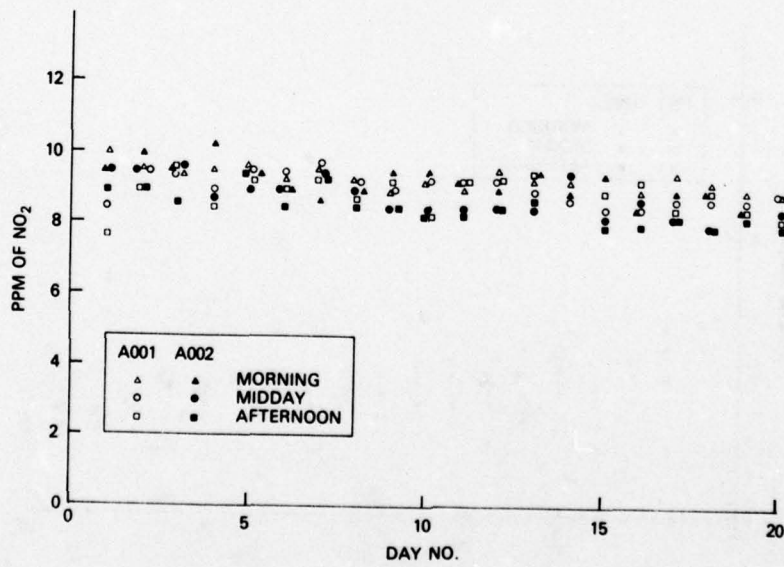

Fig. 19 — Span check for Model 6000 NO<sub>2</sub> Analyzer

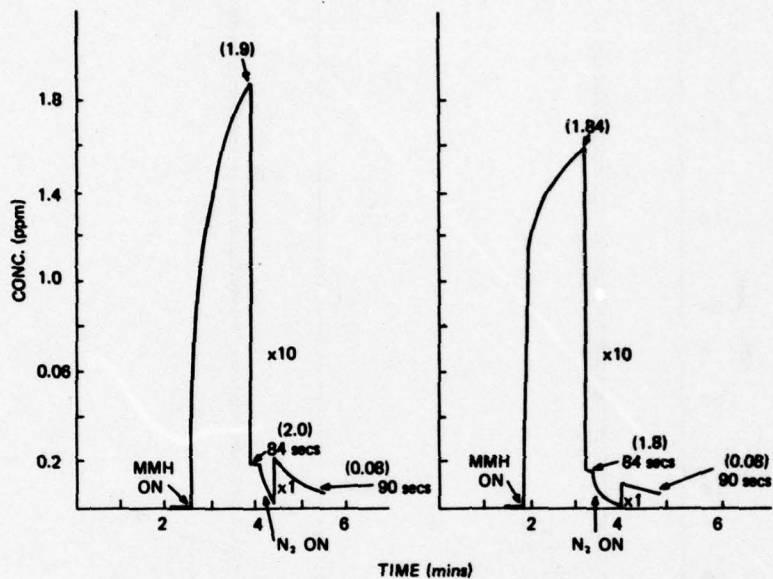

Fig. 20 — Typical MMH response curves for Model 7000 Analyzer, Instrument No. 1282

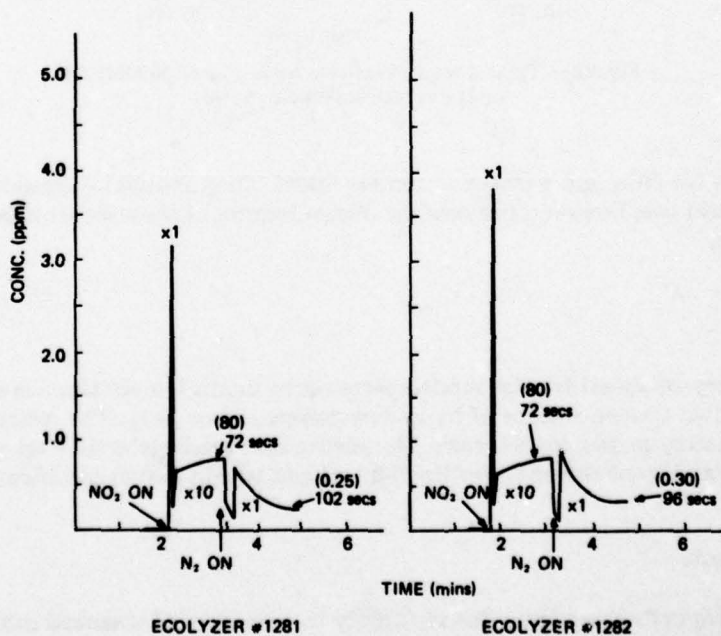

Fig. 21 — Typical NO<sub>2</sub> response curves for Model 7000 Analyzers

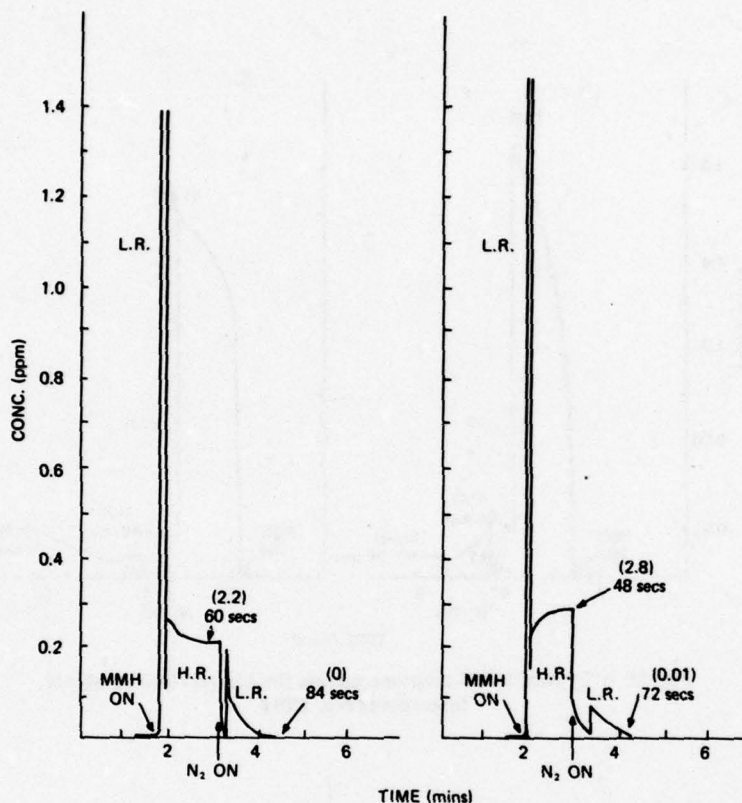

Fig. 22 — Typical response curves for Model 6000 MMH/H Analyzer, Instrument No. B1001

a factor of two for  $\text{NO}_2$  and a factor of ten for MMH. They should be considered acceptable for practical field use, however, because the design requirements were set a factor of ten less than the TLVs.

#### Battery Tests

The battery-operated Hipster models were set to monitor a continuous stream of gas containing known concentrations of hydrazine compound or  $\text{NO}_2$ . The instruments were operated on battery power for 8 h each. The instrument readings vs time are given in Tables 1 and 2. The stability of the units for the 8-h test was within design specifications.

#### Interference Tests

All detector cells were tested for sensitivity to a number of chemical interferences. The test interferences were suggested by cognizant personnel at KSC as being likely interference compounds that might be encountered during actual operations. The tests were conducted by first exposing the instruments to bagged samples of hydrazine compound or  $\text{NO}_2$  in

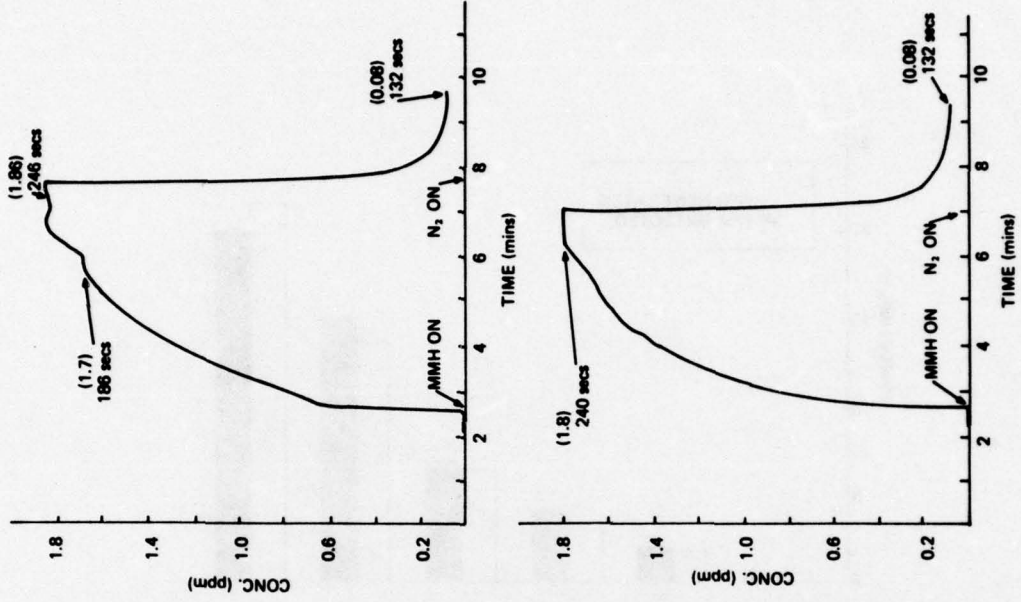

Fig. 24 - Typical response curves for MMH/H channel, Instrument No. 1281

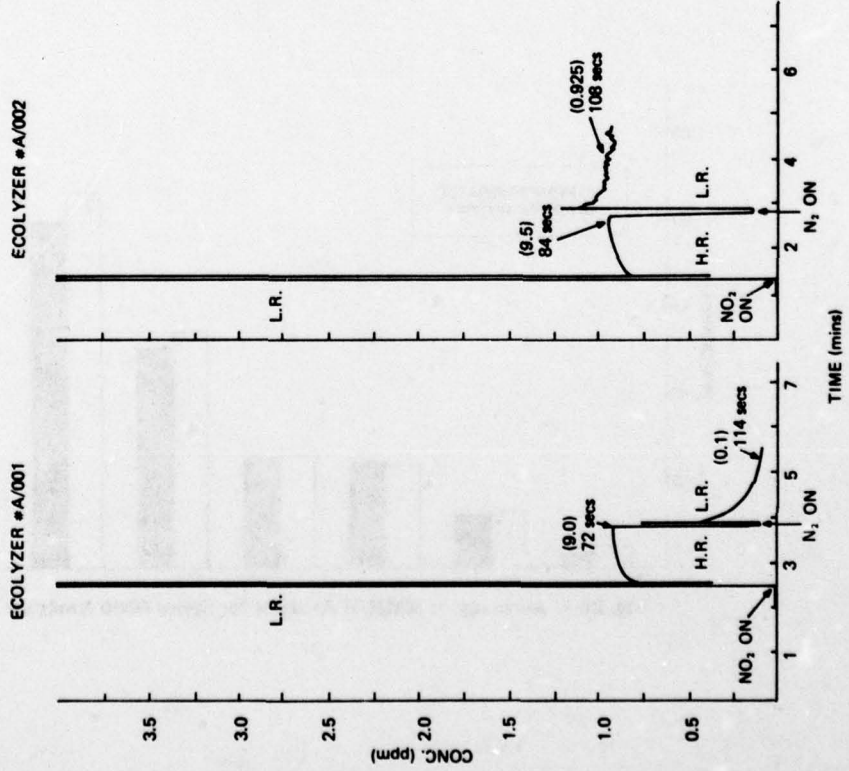

Fig. 23 - Typical response curves for Model 6000 NO<sub>2</sub> Analyzer

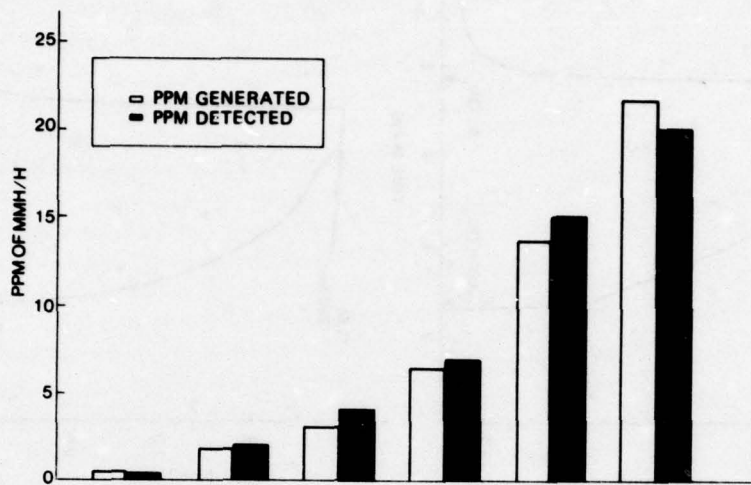

Fig. 25 — Accuracy of MMH/H Analysis for Series 7000 Analyzer

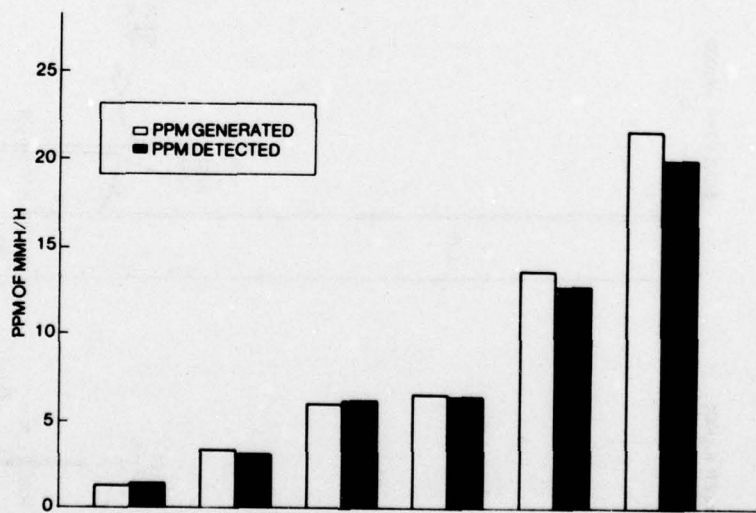

Fig. 26 — Accuracy of MMH/H Analysis for Series 6000 Analyzer

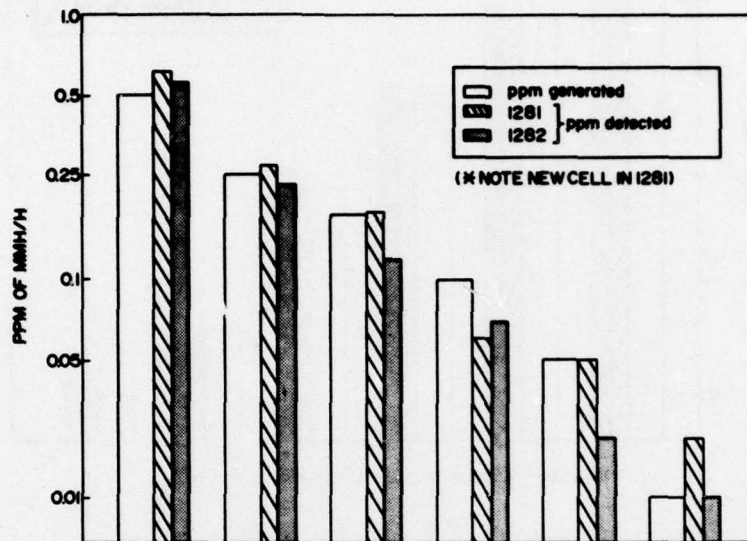

Fig. 27 — Minimum sensitivity check for MMH/H Series 7000

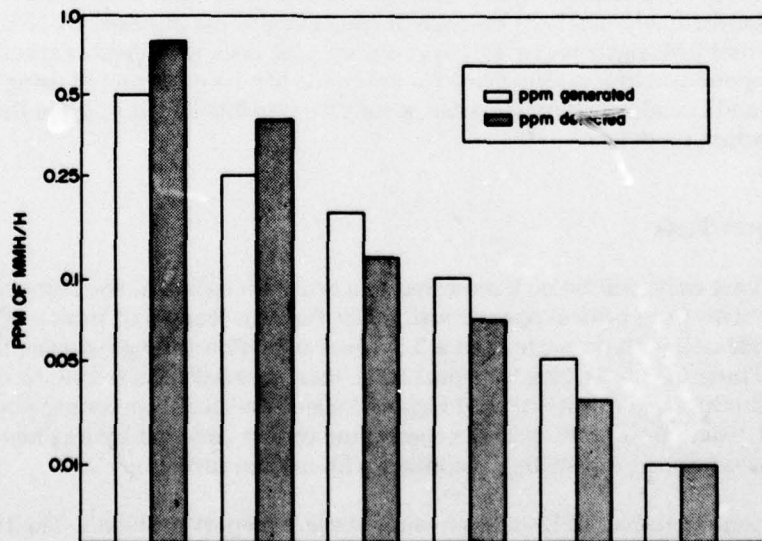
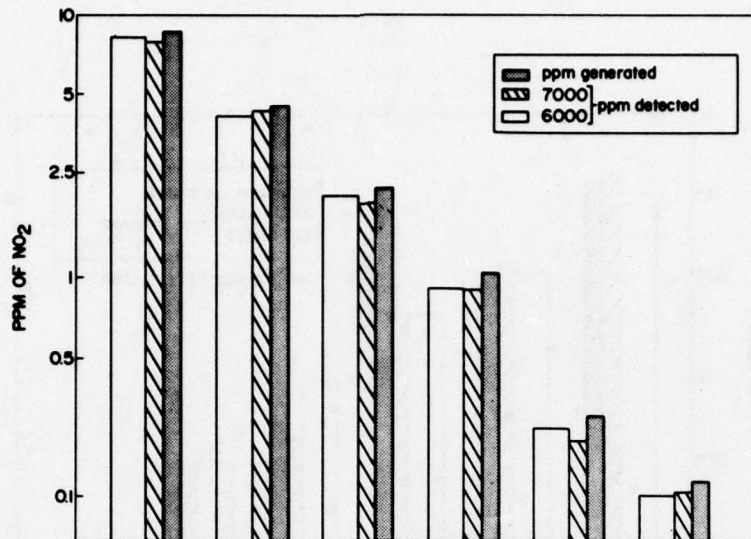

Fig. 28 — Minimum sensitivity check for MMH/H Series 6000

Fig. 29 — Minimum sensitivity check for NO<sub>2</sub>

nitrogen at known concentrations and then to a second bagged sample containing the same concentration of hydrazine compound or NO<sub>2</sub>, plus the test interferent. Only two compounds—*isopropyl alcohol* and *ammonia*—were found to cause significant interference. The results are shown in Figs. 30–34.

The prototype hydrazine detector cells were constructed with membranes containing one of ESI's standard gold catalysts because of time constraints imposed by NASA. However, experimental investigations by ESI have shown that cells with greater specificity for hydrazine compounds and less sensitivity for ammonia can be constructed using a rhodium catalyst. With additional development time, it may be possible to incorporate this improvement in production models.

#### Tubing Transport Tests

The Ecolyzer units will be rack mounted in a central location at the launching site and will sense air drawn from critical operational points through lengths of tubing. The instruments were evaluated with no more than a 3-ft piece of Teflon tubing between the sample source and the instrument. Tubing transport tests were necessary, therefore, to determine the extent of the losses in sensitivity and response time resulting from longer sample transport lines. These tests were further necessitated by the fact that hydrazine compounds are known to decompose, especially on contact with certain surfaces.

It was determined that TFE surfaces cause fewer transport problems. The tubing inner diameter is a matter of tradeoffs. Larger sizes produce a smaller pressure drop and give better surface-to-volume ratios, which result in less decomposition of hydrazine compounds. However, response time is much slower with larger tube sizes because of increased transport time. The optimum tube size was found to be 3/16 in. I.D. The data are presented

NRL REPORT 8199

Table 1 — Battery Test with Concentration of 10 ppm MMH

Time	Hipster	
8:04	Turned on	
9:07	9.25	
10:13		
12:46	9.25	
1:34	9.25	
2:19	9.25	
3:00	9.25	
		New syringe
3:08	9.5	
3:25	9.0	
3:45	8.75	Response times
4:00		Slowed down
4:15	8.75	

Table 2 — Battery Test with Concentration of 20 ppm NO<sub>2</sub>

Time	Hipster	Stability Time (s)
8:09	Turned on	
9:33	19.5	48
10:37	19.5	48
1:18	19.0	72
2:25	18.0	48
3:03	18.8	60
3:51	18.5	60
4:10	18.8	60
4:24	17.8	—

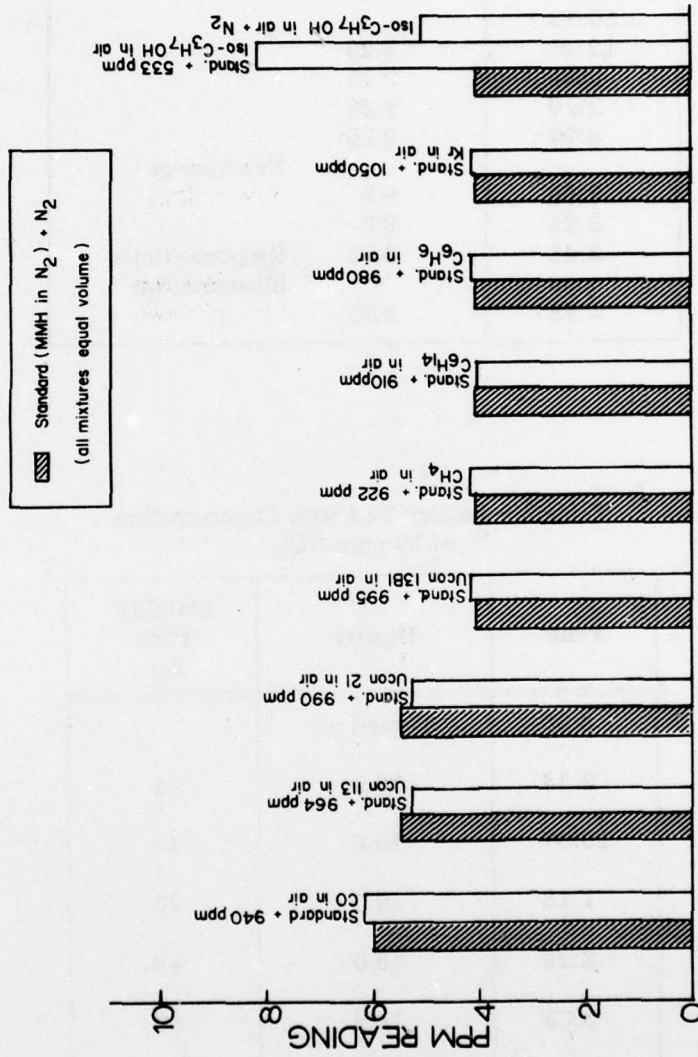

Fig. 30 — Interference test for MMH/H 7000 Series

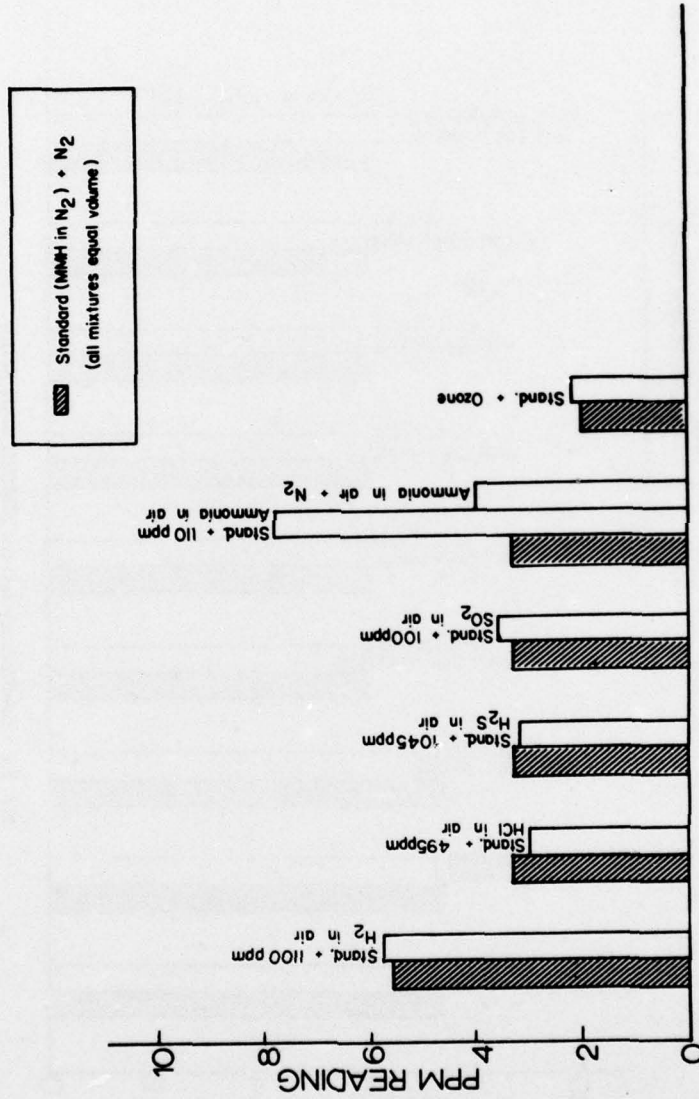

Fig. 31 — Interference test for MMH/H 7000 Series (continued)

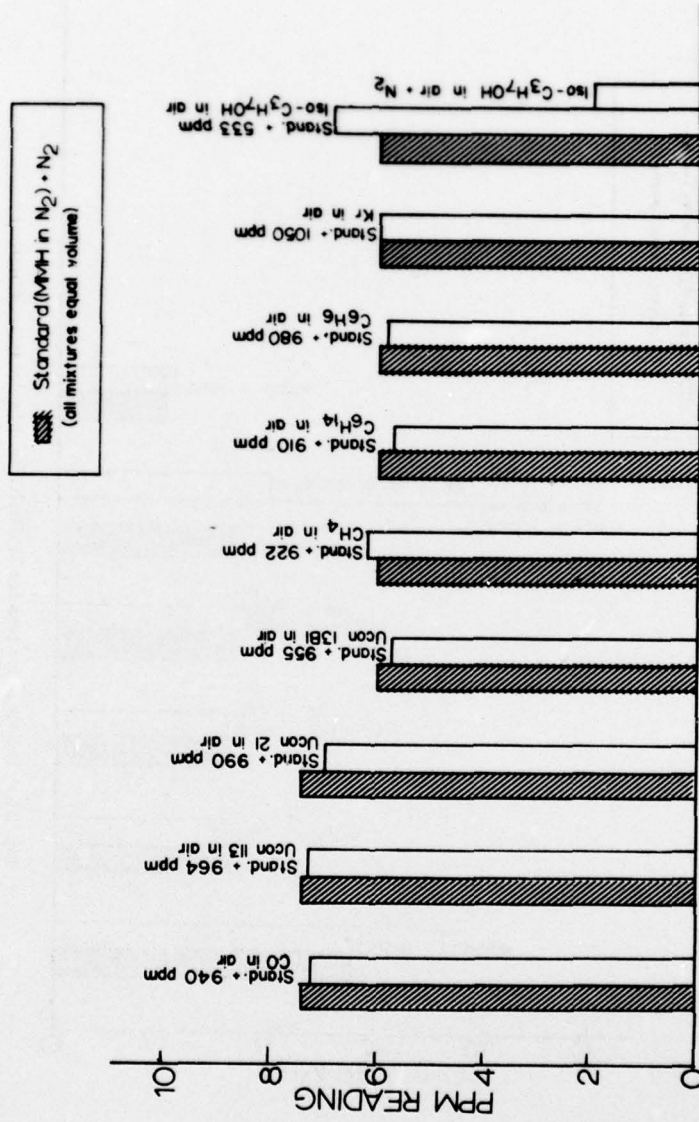

Fig. 32 — Interference test for MMH/H 6000 Series

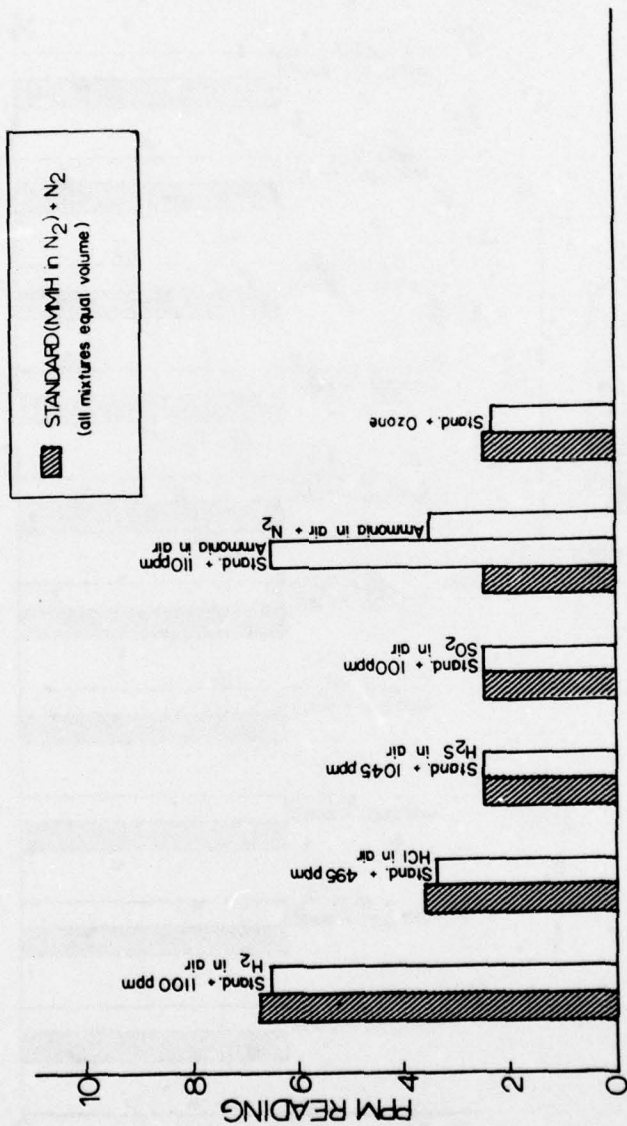

Fig. 33 — Interference test for MMH/H 6000 Series (continued)

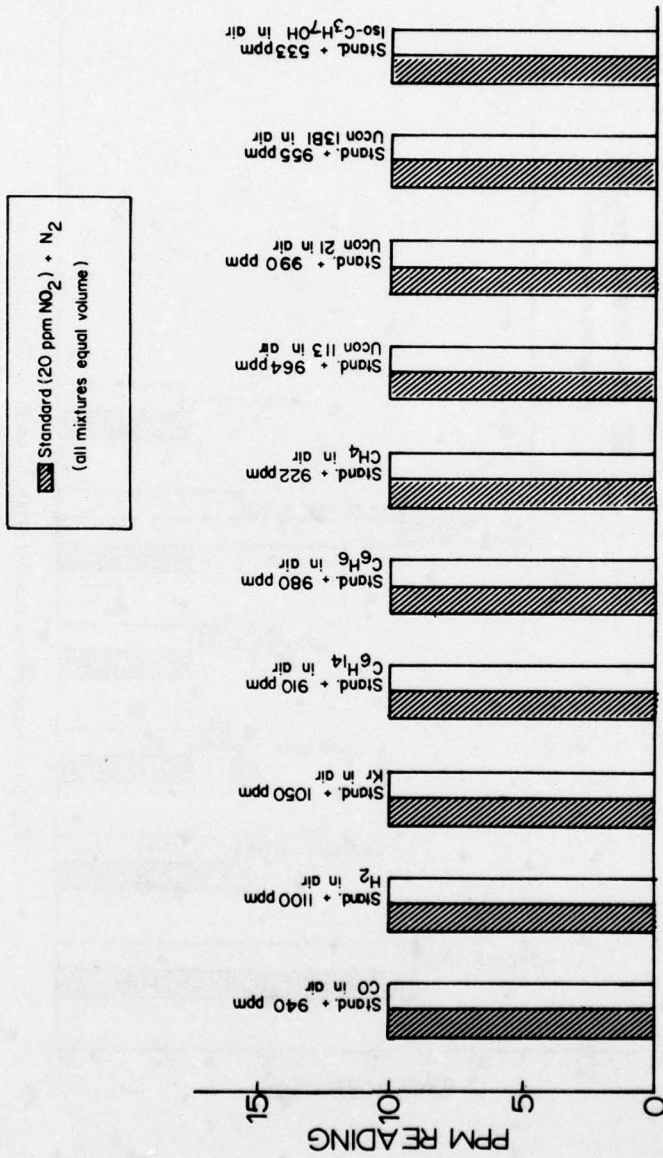

Fig. 34 — Interference test for NO<sub>2</sub> 6000 and 7000 Series

Table 3 — Transport Time Measurements

Compound	Instrument	Tubing	ppm	Initial Response Time (s)
MMH	1282	None	0.90	0
	1282	None	1.21	0
	1282	50 ft 1/4 TFE	0.98	13
	1282	50 ft 3/16 FEP	0.90	8
NO <sub>2</sub>	1281	None	7.5	0
	1282	None	8.0	0
	1281	50 ft 1/4 TFE	7.7	17
	1282	50 ft 1/4 TFE	7.5	19
	1281	50 ft 3/16 FEP	7.3	9
	1282	50 ft 3/16 FEP	7.0	11

in Table 3. Larger tube sizes could be used to advantage if an auxiliary pump were used to pull the monitoring instrument to the sampling line via a tee.

#### CONCLUSIONS AND RECOMMENDATIONS

The ESI Ecolyzer Series 6000 and 7000 instruments should satisfy NASA's current requirements for portable analyzers to monitor the environment for trace concentrations of hydrazine compounds and nitrogen dioxide. Conclusions based on extensive laboratory testing of the instruments are summarized below.

- Operation of the instruments was improved by replacing the Teflon rotary pump with a rubber bellows model. The location of the pump was also changed from a position upstream to one downstream of the sensor. This move improved instrument readout stability.
- The Teflon tubing connectors used in the instruments loosen as a result of temperature changes and mechanical vibration. This causes leaks which are deleterious to readout stability.
- The instruments are currently housed in cases designed with laboratory use in mind. Ruggedization would improve the instruments for field use. The Hipster model is built into a plastic case and is subject to interference from radio frequency radiation. This shortcoming could be eliminated by proper shielding.
- The ten sensors that were evaluated varied slightly in electrical characteristics and noise output. Better quality control in manufacture would minimize these differences and improve performance.
- Evaluation tests indicated that the span stability of the Ecolyzer model was  $\pm 0.5$  ppm on a 2-ppm scale, which is short of the  $\pm 0.25$  ppm specified. The Hipster model is somewhat orientation sensitive. As a result, it exhibits less span stability than the Ecolyzer model.

Table 4 — Design Criteria for Model 7000 NO<sub>2</sub>/MMH Analyzer

Parameter	MMH Analyzer	NO <sub>2</sub> Analyzer
Ranges (ppm)	0-2, 0-20, 0-200	0.5, 0-50, 0-500
Minimum detectable sensitivity	20 ppb	50 ppb
Rise time (90%)	90 s	<30 s
Fall time (90%)	45 s	<30 s
Zero drift*	±10%/30 days	±10%/30 days
Span drift*	±10%/30 days	±10%/30 days
Precision	2% of full scale	2% of full scale
Accuracy†	5% of full scale	1% of full scale
Noise	<1% of full scale	<1% of full scale
Operating temperature range	0-35°C	0-35°C
Operating relative humidity	10-95%	10-95%
Readout	Meter, 50 divisions mirrored Recorder, 0-5 V DC	Meter, 50 divisions mirrored Recorder, 0-5 V DC
Dimensions	8 × 8 × 16	
Weight	17 lb — (7.7 kg)	
Power	105 to 125 V AC	

\*Estimated

†Using a reference standard gas mixture of the same accuracy. With a more accurate standard reference method, an accuracy within the specified precision can be achieved.

• The zero stability, response time and accuracy of all of the instruments were within specifications. The sensitivity of the instruments was also adequate, but it should be noted that sensitivity determinations were made under ideal laboratory conditions with the instruments immobilized. Very small meter deflections could be detected using a recorder output. However, in field use, without a recorder, the sensitivity of the instruments is likely to be less satisfactory.

• The instruments performed satisfactorily on battery power for the required 8-h period. No problems were noted with charge/discharge cycles. Finally, the instruments were exposed to numerous chemical gases to check for signal interference. Only ammonia and isopropyl alcohol gave rise to spurious signals.

The instruments satisfy design criteria with two minor exceptions that should not affect instrument utility. Design criteria are listed in Tables 4, 5 and 6.

The design goal for the minimum detectable level of hydrazine compound was 20 ppb. Both instruments reached this under ideal laboratory conditions while operating with recorder output. The limit of detection for field use might be less favorable. A minimum detectable concentration of 0.2 ppm in field use would permit hydrazine compounds to be monitored at their present OSHA limits. A draft of an undated National Institute of Occupational Safety and Health (NIOSH) Criteria Document for Hydrazine Compounds,

Table 5 — Design Criteria for Model 6000 Portable NO<sub>2</sub> Analyzer

Item	Characteristic
Charging power requirements	110 to 120 V AC, 50/60 Hz
Charging time	Overnight (approx. 16 h)
Operating time with full charge	Eight (8) h of continuous operation
Standby power consumption	No more than 48 h between charging and use
Standard ranges (dual)	NO <sub>2</sub> 0—5 ppm and 0—50 ppm
Response time	90% of signal within 30 s
Accuracy	±2% of full-scale range
Reproducibility	±2% of full scale
Noise	<1% of full scale
Stability*	
Zero drift	±2% of full scale per day
Span or calibration	±2% of range per day
Operating temperature (For full accuracy)	32° F — 104° F
Operating relative humidity range	5% to 95% RH
Physical dimensions	3 in. X 5 in. X 8 in.
Weight	3.5 lb

\*The Hipster's maximum zero and span drift are estimated for most severe operating conditions (i.e., <5% RH, continuous 8-h daily operation). Less severe usage results in better instrument stability than these extreme limits.

circulated in December 1977, proposed that occupational exposures to H and MMH be controlled so that no employees are exposed to concentrations greater than 0.07 ppm and 0.125 ppm, respectively, determined as ceiling concentrations during any 15-min sampling period.

The measured daily span stability of the instruments for hydrazine compounds exceeded the design goal by a factor of two. However, the observed span stability was constant and should not affect instrument utility. The Series 6000 instruments, which are hand-carried units, exhibit a higher degree of span drift than the Series 7000 instruments. The increased drift results from changes in the instrument's physical orientation while being hand carried and is attributable to the quality of the panel meter. The span drift problems can be minimized by improving the quality control of the meters and detector cells.

These instruments exhibit some response to isopropyl alcohol and ammonia. The other substances tested for interference gave no response. The detector cells in the prototype instruments were constructed using off-the-shelf components and current technology. The manufacturer believes that, with additional time, more selective detectors could be developed.

Table 6 — Design Criteria for Model 6000 Portable Analyzer for Hydrazine Compounds

Item	Characteristic
Charging power requirements	110 V to 120 V AC, 50/60 Hz
Charging time	Overnight (approx. 16 h)
Operating time with full charge	Eight (8) h of continuous operation
Standby power consumption	No more than 48 h between charge and use
Ranges (dual)	MMH 0—2 ppm and 0—20 ppm
Response time	90% of signal within 30 s
Accuracy*	±5%
Reproducibility	±1% of full scale
Noise	<1% of full scale
Stability	
Zero drift	<±2% of full scale per day
Span or calibration	<±2% of range per day
Operating temperature	32° F — 104° F
Operating relative humidity range	5% to 95% RH
Physical dimensions	3 in. × 5 in. × 8 in.
Weight	3.5 lb

\*Reflects the accuracy of the reference calibration method.

Production units based on these prototypes should reflect some of the improvements suggested in this report. It is recommended that NASA accept these instruments in fulfillment of its current needs for analyzers to monitor the environment for trace concentrations of certain hypergolic fuels.

#### REFERENCES

1. R. A. Saunders and J. T. Larkins, "Detection and Monitoring of Hydrazine, Monomethylhydrazine and Their Decomposition Products, A Final Report," NRL Memo Report 3313, June 1976.
2. H. McKennis and A. S. Yard, "Determination of Methylhydrazine," *Anal. Chem.* **26**, 1960 (1954).